

RAILROAD STRUCTURES AND ESTIMATES

BY
J. W. ORROCK, C.E.
STRUCTURAL ENGINEER

FIRST EDITION
FIRST THOUSAND



NEW YORK
JOHN WILEY & SONS
LONDON: CHAPMAN & HALL, LIMITED
1909

TF270
08

GENERAL

MCC

COPYRIGHT, 1909,
BY
J. W. ORROCK

Stanbope Press
F. H. GILSON COMPANY
BOSTON, U.S.A.

PREFACE.

UNDER the title of Railroad Structures and Estimates, the intention is to cover in brief and concise form, the numerous subjects that enter into the Engineer's Estimates of Railroad Building; for the purpose of ready reference, as to general construction and cost, on a business rather than a technical basis.

As it is impossible to give data to suit all conditions, the weights, quantities, and cost, are given in detail in most instances, and may be varied as desired.

The author is indebted to H. M. Mackay, Professor of Civil Engineering, McGill University, for a number of suggestions embodied in the manuscript, and to J. G. Sullivan, Assistant Chief Engineer, for permission to use C. P. Ry. Illustrations.

TABLE OF CONTENTS

CHAPTER I.

TRACK MATERIAL.

	PAGE
Approximate Quantities and Cost of Rails—Splices—Bolts and Nuts— Spikes—Ties—Ballasting—Surfacing—Track Laying—Tie Plates— Summary Track Material above Subgrade—Grading—Overhaul— Tile Drains—Cross-waying—Clearing—Trees—Grubbing—Switches— Frogs—Stands—Lamps, etc.....	3-25

CHAPTER II.

FENCES, GATES, SIGN POSTS, ROAD CROSSINGS AND GUARDS.

Approximate Quantities and Cost of Wire Fence—Picket Fence—Snow Fence—Safety Crossing Gates—Farm Crossing Gates—Sign Boards and Posts—Bridge Warnings—Mail Cranes—Road Crossings—Over- head Farm Crossings—Cattle Guards, etc.....	26-42
---	-------

CHAPTER III.

CULVERTS.

Approximate Quantities and Cost of Tile Pipe Culverts—Concrete Pipe Culverts, Mortar Joints—Cast Iron Pipe Culverts—Lead and Yarn Joints—Concrete Arch Culverts—Rail Concrete Culverts—Stone and Wooden Box Culverts.....	43-52
--	-------

CHAPTER IV.

BRIDGES.

Approximate Quantities and Cost of Deck Plate Girders—Half Deck Plate Girders—Deck and Through Trusses—Drawbridges—Abut- ments—Piers—Timber Trestles—Steel Trestles—Howe Trusses— Subways—Overhead Crossings—Bridge Guards—Retaining Walls— Cribs—Tunnels, etc.....	53-86
---	-------

CHAPTER V.

BUILDINGS.

	PAGE
Approximate Estimate and Cost of Tool Houses—Watchman's Shanty— Section Houses—Privies—Stations—Station Furniture—Platforms— Freight Sheds—Teamways—Engine Houses—Boiler Houses—Store- houses—Oil Houses—Ice Houses—Ice Making—Cold Storage—Coal- ing Stations—Ash Pits—Sand Houses—Track Scales—Stock Yards— Snow Sheds—Turntables, etc.	87-173

CHAPTER VI.

WATER STATIONS.

Approximate Estimate and Cost of Pumps—Boilers—Service Pipes— Pump House—Tanks—Standpipes—Dams—Track Tanks, etc. . . .	174-206
---	---------

CHAPTER VII.

SHOPS.

Approximate Estimate and Cost of Blacksmith—Cabinet—Car Machine —Car Truck—Dry Kiln—Foundry—Freight Car—Frog and Switch— Locomotive—Boiler—Machine—Passenger Car—Planing Mill—Power House—Stores, etc.	207-218
--	---------

CHAPTER VIII.

SPECIFICATIONS AND CONTRACTS.

Instructions Regarding Specifications—Forms—Proposals—Contracts, Plans, and Estimates	219-248
--	---------

CHAPTER IX.

ESTIMATING NOTES.

Excavation—Masonry—Piling—Riprapping—Paving—Brickwork— Steel and Iron Work—Steel and Concrete—Paint—Timber—Carpen- try—Roofing—Plaster, etc.	249-262
---	---------

RAILROAD STRUCTURES AND ESTIMATES



RAILROAD STRUCTURES AND ESTIMATES

CHAPTER I.

TRACK MATERIAL.

Rail.

THE standard rail section recommended by the American Society of Civil Engineers is now generally used, manufactured mostly by the Bessemer Steel Process. Delivered in 33-foot lengths, ends sawed square and bolt holes for splice connections accurately drilled. A small percentage in shorter lengths is generally accepted; the best rails are usually termed No. 1, and those not of the best No. 2. No. 1 rail only, is used in main line or fast running track.

Rails are bought and paid for on the actual weight, and are usually quoted in gross tons (2240 pounds) and weight per yard (3 lineal feet).

General Chemical Composition.

Carbon.....	0.45 to 0.65 per cent.
Phosphorus.....	0.06 to 0.85 per cent.
Silicon.....	0.10 to 0.20 per cent.
Manganese.....	0.75 to 1.05 per cent.
Sulphur.....	0.03 to 0.07 per cent.

General Physical Properties.

Elastic limit.....	55,000 to 65,000 lbs. per sq. in.
Ultimate strength.....	110,000 to 120,000 lbs. per sq. in.
Elongation.....	12 to 15 per cent. (8 or 10 in.)
Modulus of elasticity.....	29,000,000 to 30,000,000 lbs.

One mile of single track requires:

10,560 lineal feet, or 3520 yards.
352 rails if 30 feet long.
320 rails if 33 feet long.

To find the number of gross tons of rail required for one mile of single track, divide the weight per yard by 7 and multiply by 11.

Example. — For 70 pounds rail, $(70 \div 7) \times 11 = 110$ tons per mile.

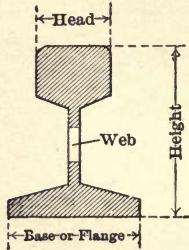

Fig. 1. Rail Section.

TABLE 1. — QUANTITY AND APPROXIMATE COST OF RAILS PER MILE, SINGLE TRACK.

Section modulus.	Rail dimensions.				Weight per yard, lbs.	Ft. of track per ton.	Tons per 100 ft. track.	Tons (2240 lbs.) per mile.	Material only F. O. B. cars.*		
	Height.	Width.	Head.	Web.					Cost per mile at \$31 per ton.	Cost per mile at \$.. per ton.	Cost per mile at \$.. per ton.
	In.	In.	In.	In.					Dol.	Dol.	Dol.
6	4 $\frac{1}{8}$	4 $\frac{1}{8}$	2 $\frac{1}{4}$	$\frac{3}{8}$	56	60.00	1.67	88.00	2728
6.7	4 $\frac{1}{2}$	4 $\frac{1}{2}$	2 $\frac{3}{8}$	$\frac{3}{8}$ $\frac{1}{4}$	60	56.00	1.79	94.29	2923
7.4	4 $\frac{7}{16}$	4 $\frac{7}{16}$	2 $\frac{3}{2}$	$\frac{1}{2}$	65	51.69	1.94	102.12	3166
8.2	4 $\frac{5}{8}$	4 $\frac{5}{8}$	2 $\frac{7}{16}$	$\frac{3}{8}$ $\frac{3}{4}$	70	48.00	2.09	110.00	3410
9.3	4 $\frac{13}{16}$	4 $\frac{13}{16}$	2 $\frac{1}{2}$	$\frac{1}{2}$ $\frac{1}{2}$	75	44.80	2.24	117.86	3654
10.0	5	5	2 $\frac{1}{2}$	$\frac{3}{8}$ $\frac{5}{4}$	80	42.00	2.38	125.71	3897
11.0	5 $\frac{3}{16}$	5 $\frac{3}{16}$	2 $\frac{9}{16}$	$\frac{9}{16}$	85	39.53	2.53	133.57	4141
12.0	5 $\frac{1}{2}$	5 $\frac{1}{2}$	2 $\frac{5}{8}$	$\frac{9}{16}$	90	37.33	2.68	141.43	4384
13.3	5 $\frac{9}{16}$	5 $\frac{9}{16}$	2 $\frac{1}{8}$	$\frac{9}{16}$	95	35.37	2.83	149.29	4628
14.6	5 $\frac{1}{4}$	5 $\frac{1}{4}$	2 $\frac{1}{4}$	$\frac{9}{16}$	100	33.60	2.99	157.14	4871

NOTE. — For condensed cost of track material per mile, above subgrade, see table 7, p. 13.

* Price for track rails F. O. B. Chicago, 1908 delivery, \$28.00 per gross ton.

Add your own prices and records in blank spaces.

Splices.

Fish plates, angle bars and special fastenings for connecting the rails at joints, are made in a variety of designs; the ordinary kind in common use are the four and six hole angle bars; usually quoted in gross tons (2240 pounds).

The short four-hole angle bar suspended rail joint only will be considered, as this is generally the most acceptable splice in service.

Material.

High-carbon steel open hearth or basic open hearth.

Average Chemical Composition.

Carbon not to exceed.....	0.15 per cent.
Phosphorus not to exceed.....	0.10 per cent.
Manganese not to exceed.....	0.40 to 0.60 per cent.

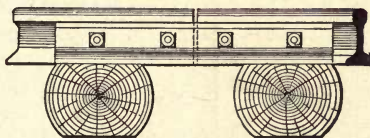

Fig. 2. Rail Splice.

Average Physical Properties.

Ultimate strength.....	60,000 to 90,000 lbs. per sq. in.
Elastic strength.....	30,000 to 45,000 lbs. per sq. in.
Elongation in 8 inches not less than	25 per cent.
Reduction in area not less than	30 per cent.

One Mile Single Track Requires

352 pairs angle bars for 30-foot rails.
320 pairs angle bars for 33-foot rails.

TABLE 2. — QUANTITY AND APPROXIMATE COST 4-HOLE ANGLE BAR RAIL JOINTS PER MILE, SINGLE TRACK.

Weight of rail.	Length of bar.	Weight per pair.	30-ft. rail lengths.				33-ft. rail lengths.			
			Lbs. per mile of track.	Lbs. per 100 ft. of track.	Material only F. O. B. cars.*		Lbs. per mile of track.	Lbs. per 100 ft. of track.	Material only F. O. B. cars.*	
					Cost per mile at 2 cts. per lb.	Cost per mile at . . cts. per lb.			Cost per mile at 2 cts. per lb.	Cost per mile at . . cts. per lb.
Lbs.	In.	Lbs.			Dol.	Dol.			Dol.	Dol.
56	24	30	10560	200	212	9600	182	192
60	24	33	11616	220	233	10560	200	212
65	24	36	12670	240	254	11520	218	231
70	26	42	14784	280	296	13440	255	269
75	26	45	15840	300	317	14400	273	288
80	26	49	17248	327	345	15680	297	314
85	26	53	18656	354	374	16900	320	338
90	28	61	21472	407	430	19520	370	391
95	28	66	23232	440	465	21120	400	423
100	28	71	24992	474	500	22720	430	455

NOTE. — For condensed cost of track material per mile, above subgrade, see table 7, p. 13.

* Price for angle bars accompanying rail orders, F. O. B. Chicago, 1908 delivery, 1.5 cts.; car lots.

Bolts and Nuts.

The ordinary rolled or cut thread shouldered track bolts are made of steel $\frac{3}{4}$ inch to 1 inch thick, in lengths to suit rails and fastenings used, and are generally put up in kegs of 200 and 224 pounds in weight. The nuts are either hexagon or square. The Harvey grip, or other approved form of bolt, is generally used, requiring no nutlocks.

Average Chemical Composition.

Soft Bessemer steel with carbon not to exceed 0.15 per cent.

Add your own prices and records in blank spaces.

Average Physical Properties.

Ultimate strength..... 54,000 to 64,000 lbs. per sq. in.
 Elastic limit..... 27,000 to 32,000 lbs. per sq. in.
 Elongation in 8 inches not less than 25 per cent.

One Mile of Track Requires

1408 bolts and nuts for 4-hole splice bars, 30-foot rail lengths.
 1280 bolts and nuts for 4-hole splice bars, 33-foot rail lengths.

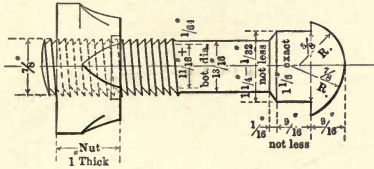

Fig. 3. Harvey Grip Bolt.

TABLE 3. — QUANTITY AND APPROXIMATE COST OF BOLTS AND NUTS PER MILE, SINGLE TRACK.

Bolt dimensions.			30-ft. rail lengths.						33-ft. rail lengths.					
Rail weight per yd.	Size of bolt.	Weight per bolt.	Aver. number in keg 200 lbs.	Number of kegs per mile.	Tons per mile (2000 lbs.).	Material only F. O. B. cars.*			Number of kegs per mile.	Tons per mile (2000 lbs.).	Material only F. O. B. cars.*			
						Cost per mile at \$75 per ton (2000 lbs.).	Cost per mile at \$50.	Cost per mile.			Cost per mile at \$75 per ton (2000 lbs.).	Cost per mile at \$50.	Cost per mile.	
Lbs.	In.	Lbs.				Dol.	Dol.	Dol.			Dol.	Dol.	Dol.	
56	3 1/2 x 7/8	1.20	170	8.4	0.84	63.00	42	7.7	0.77	57.75	38.50	
60	3 3/4 x 7/8	1.25	160	8.8	0.88	66.00	44	8.7	0.80	60.00	40.00	
65	3 3/4 x 7/8	1.25	160	8.8	0.88	66.00	44	8.7	0.80	60.00	40.00	
70	4 1/8 x 7/8	1.33	150	9.4	0.94	70.50	47	8.5	0.85	63.75	42.50	
75	4 1/8 x 7/8	1.33	150	9.4	0.94	70.50	47	8.5	0.85	63.75	42.50	
80	4 3/8 x 7/8	1.4	143	9.9	0.99	74.25	49.50	9.0	0.90	67.50	45	
85	4 3/8 x 7/8	1.4	143	9.9	0.99	74.25	49.50	9.0	0.90	67.50	45	
90	4 1/2 x 7/8	1.5	134	10.6	1.06	79.50	53	9.6	0.96	72.00	48	
95	4 1/2 x 7/8	1.5	134	10.6	1.06	79.50	53	9.6	0.96	72.00	48	
100	4 7/8 x 1	1.9	105	13.4	1.34	100.50	57	12.2	1.22	91.50	61	

NOTE. — For condensed cost of track material per mile, above subgrade, see table 7, p.13.

* Price for common bolts and nuts F. O. B. Chicago, 2.15 cts. to 2.20 cts. base, square nuts, 2.3 cts. to 2.35 cts. base, hexagon nuts.

Add your own prices and records in blank spaces.

Spikes (Open-Hearth Steel).

The ordinary railroad spike in general use is $\frac{9}{16}$ inch square \times $5\frac{1}{2}$ inches long for rails over 45 pounds per yard in weight. They are usually put up in boxes or kegs of 200 and 224 pounds.

Boat spikes $\frac{3}{8}$ inch \times 8 inches are used for spiking frogs and switch blocking to the ties, and long track spikes 7, 8 and 9 inches in length for shimming work.

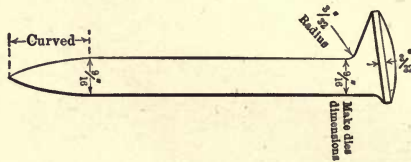

Fig. 4. Track Spike.

Average Chemical Composition.

Carbon	0.12 to 0.25 of one per cent.
Manganese.....	0.50 of one per cent.
Silicon	0.05 of one per cent.
Phosphorus	0.04 of one per cent.
Sulphur	0.04 of one per cent.

Average Physical Properties.

Ultimate strength.....	50,000 to 70,000 lbs. per sq. in.
Elastic limit.....	27,000 to 35,000 lbs. per sq. in.
Elongation in 8 inches	not less than 20 per cent.
Reduction in area at point of fracture	not less than 35 per cent.

Tests.

The body shall be bent, both hot and cold, through 180 degrees, flat on itself, without sign of fracture on the outside.

The body shall be twisted cold one and one-half turns without sign of fracture.

The underside of the head shall be bent backwards cold by one blow of a hammer into line lengthwise with the face of the body without sign of fracture. The same test shall be made when the neck is ground half through.

TRACK MATERIAL.

TABLE 4. — QUANTITY AND APPROXIMATE COST OF SPIKES PER MILE SINGLE TRACK.

3500 ties per mile.								
Size of spike.	Aver. number per 200-lb. keg.	Weight per spike.	Number of kegs per mile of track.	Lbs. per 100 ft. of track.	Tons per mile (2000 lbs.).	Material only F. O. B. cars.*		
						Cost per mile at \$56 per ton.	Cost per mile at \$40 per ton.	At \$. . per ton.
In.		Lbs.				Dol.	Dol.	
4½ × ½	530	.38	27	104	2.75	154	100
5 × ½	490	.40	29	110	2.90	163	116
5 × ⅞	360	.52	39	148	3.90	219	156
5½ × ⅞	340	.58	42	160	4.20	236	168

3000 ties per mile.								
In.		Lbs.				Dol.	Dol.	
4½ × ½	530	.38	23	88	2.3	129	92
5 × ½	490	.40	25	96	2.5	140	100
5 × ⅞	360	.52	34	130	3.4	191	136
5½ × ⅞	340	.58	36	137	3.6	202	144

2600 ties per mile.								
In.		Lbs.				Dol.	Dol.	
4½ × ½	530	.38	20	75	2	112	80
5 × ½	490	.40	22	84	2.2	124	88
5 × ⅞	360	.52	29	110	2.9	163	116
5½ × ⅞	340	.58	31	118	3.1	174	124

Boat spikes for shimming, etc.:

- 7" × ⅜", 650 per keg (200 lbs.).
- 8" × ⅜", 600 per keg (200 lbs.).
- 9" × ⅜", 525 per keg (200 lbs.).

NOTE.—For condensed cost of track material per mile, above subgrade, see table 7, p. 13.

* Price for common track spikes F.O.B. Chicago, 1908 delivery, 1.80 cts. to 1.90 cts. per lb.

Add your own prices and records in blank spaces.

Ties.

The ordinary ties are 8 feet long, 6 to 8 inches thick and 8 to 10 inches wide, ends sawed square. The most common kind are of pine, spruce, hemlock, cedar, oak, including various other timbers that can be procured locally. They are usually classed No. 1 ties when of first quality, and No. 2 when conforming with No. 1, excepting that the thickness is an inch or so less; those failing to pass inspection as No. 1 or No. 2, are designated "Culls"; the latter, if sound and otherwise fit, are used in sidings, spurs, etc.

Owing to the growing scarcity of timber, many railroads are treating ties by a chemical process so as to retard decay; the cost of the treatment paying for the extra years' service obtained. As it requires a number of years to demonstrate its usefulness and economy, the development is in consequence very slow and uncertain. Steel and concrete ties are mainly experimental and are used to a limited extent. The number of wood ties per rail length varies from 18 to 20 per 33-foot rail length, and cost from 35 cents to 75 cents per tie or more. Probably a fair average is 50 cents delivered on the site, but not placed.

Switch Ties. — For turnouts and crossovers sawn oak ties, or good quality local timber is used, varying in length to suit the switch layout. For quantity and cost, see under Switches.

TABLE 5. — QUANTITY AND APPROXIMATE COST TRACK TIES PER MILE, SINGLE TRACK.

Distance center to center about	Average number of ties per mile.	Number per 100 ft. of track.	Cost per mile. — Material only, F. O. B. cars.*						
			At 50 cts. each.	At 45 cts. each.	At 40 cts. each.	At .. cts. each.	At .. cts. each.	At .. cts. each.	At .. cts. each.
Ia.			Dol.	Dol.	Dol.	Dol.	Dol.	Dol.	Dol.
18	3500	67	1750	1575	1400
21	3000	57	1500	1350	1200
24	2600	50	1300	1170	1040
30	2100	41	1050	945	840

NOTE. — For condensed cost of track material per mile, above subgrade, see table 7, p. 13.

* Prices for ties F. O. B. Chicago, 1908 delivery, 6" × 8" × 8' oak, 1st grade, 74 cts. each. 6" × 8" × 8' oak, 2d grade, 67 cts. each.

Add your own prices and records in blank spaces.

Ballasting, etc.

Ballasting. — Ballasting consists in procuring selected material for the road-bed to make good track, and includes the loading, hauling, unloading and transportation of all material hauled by train or otherwise for the purpose of surfacing the track; the material is usually gravel, cinders, broken stones, slag, etc., and the average depth 8 to 12 inches.

Approximate cost.	Actual cost.
Cinder ballasting, 15 to 50 cts. per cubic yard
Gravel ballasting, 20 to 30 cts. per cubic yard.....
Stone ballasting, 60 cts. to \$1.25 per cubic yard.....

Loading gravel on cars by steam shovel, 5 to 12 cents per cubic yard.

Surfacing. — Surfacing includes all work in placing surface material under the track, tamping, lining, and all other work incident to the preparation of the track for operation.

Approximate cost.	Actual cost.
Surfacing with cinders, 10 to 15 cts. per cubic yard...
Surfacing with gravel, 15 to 25 cts. per cubic yard
Surfacing with broken stone, 25 to 40 cts. per cubic yard

TABLE 6. — APPROXIMATE QUANTITIES AND COST OF BALLASTING AND SURFACING PER MILE, SINGLE TRACK.
(Including Ballast between Ties.)

Kind of ballast.	Cu. yds.	Approximate cost per yd.	Approximate cost per mile.	Actual cost per mile.
10" gravel.....	1700	\$0.35	\$595.00
10" rock.....	1900	1.25	2375.00
12" gravel.....	2000	.35	700.00
12" rock.....	2200	1.25	2750.00
15" gravel.....	2500	.35	875.00
15" rock.....	2800	1.25	3500.00

NOTE.— For condensed cost of track material per mile, above subgrade, see table 7, p. 13.
Add your own prices and records in blank spaces.

Tracklaying. — Tracklaying includes all work in the laying of ties and track material, turnouts, switches, crossings, etc., and such necessary cutting down and filling up as may be necessary to allow the safe passage of trains before final surfacing.

Approximate cost. — One mile of single track, \$350 to \$500.

Record of actual cost: —

Tie Plates. — The plates are made of mild steel with .20 to .25 of one per cent of carbon, and are sheared and punched to template.

The ordinary tie plate is 5 inches wide and 8 inches long, $\frac{3}{8}$ to $\frac{1}{2}$ inch thick, with ribs on the under side, which enter the wood and prevent slipping; the spike holes are arranged so that the plates will not be right and left. Tie plates with a shoulder or rib on top to fit against the outside edge of rail are also used.

The plates increase the life of ties and prevent spreading of track, canting of rails and the cutting of ties by rail pressure, and excepting at joints are usually placed in pairs one on each end of the same tie.

All ties on curves including turnouts and all soft ties on tangents are usually tie plated, held down by two spikes on tangents and three or four on curves. In general, three spikes should be used on curves less than 6 degrees and four on curves over 6 degrees.

The average weight of the ordinary tie plate is about 4 pounds, and using 3000 ties to the mile, 6000 plates would be necessary, which at a cost of 12½ cents each in place would total per mile \$750.

Record of actual cost: —

Add your own prices and records in blank spaces.



TRACK MATERIAL.

Rail Braces.—Rail braces are used principally on guard rails, switches and curves, and are generally placed in pairs one on each end of the same tie. They are made of cast iron and pressed steel in a variety of forms to fit the rail and support it laterally, and are spiked down to ties with three or more spikes. The pressed steel rail brace weighs about 4 pounds.

Cost. — 10 to 15 cents each in place.

Record of actual cost: —

TABLE 7. — APPROXIMATE COST OF ONE MILE OF SINGLE MAIN LINE TRACK, ABOVE SUBGRADE.

(Summary.)

Rails (33-ft. lengths) at \$31 per ton.			Splices at \$44.80 per ton (2000 lbs.).		Bolts and nuts at \$75 per ton (2000 lbs.).		Spikes at \$56 per ton.		Ties 3000 per mile at 45 cts. each.	Ballasting and surfacing.	Tracklaying.	Cost per mile.	Cost per foot of track.
Wt.	Tons.	Dol.	Tons.	Dol.	Tons.	Dol.	Tons.	Dol.	Dol.	Dol.	Dol.	Dol.	Dol.
56	88.00	2728	4.29	192	0.77	58	3.6	202	1350	875	250	5655	1.07
60	94.29	2923	4.72	212	0.80	60	3.6	202	1350	875	250	5872	1.11
65	102.12	3166	5.18	231	0.80	60	3.6	202	1350	875	250	6134	1.16
70	110.00	3410	6.05	269	0.85	64	3.6	202	1350	875	300	6470	1.23
75	117.86	3654	6.44	288	0.85	64	3.6	202	1350	875	300	6733	1.28
80	125.71	3897	7.00	314	0.90	68	3.6	202	1350	875	400	7106	1.35
85	133.57	4141	7.50	338	0.90	68	3.6	202	1350	875	400	7374	1.40
90	141.43	4384	8.72	391	0.96	72	3.6	202	1350	875	400	7674	1.46
95	149.29	4628	9.40	423	0.96	72	3.6	202	1350	875	450	8000	1.52
100	157.14	4871	10.11	455	1.73	92	3.6	202	1350	875	450	8295	1.58

Add your own prices and records in blank spaces.

Ballast Sections.

The following ballast sections are recommended as good practice by the A. Ry. Eng. and M. of Way Association.

The section for class A track is intended to show minimum depth under ties and is recommended for use only on the firmest, most substantial and well-drained subgrades.

The sodding of the roadbed shoulder next to ditch and of the slopes of the ditch is recommended.

The slag, which should be dressed to section shown for crushed rock and slag, is broken slag, similar in character to crushed rock.

Granulated slag should be dressed to section for gravel, cinders, chats, etc.

Class "A" gravel, cinders, chats, etc., also cementing gravel and chert Class B, the ballast slopes 3 to 1 from end of ties to subgrade instead of 2 to 1 as shown.

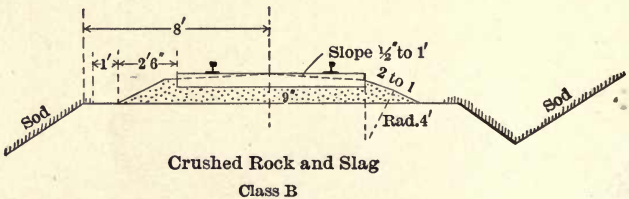
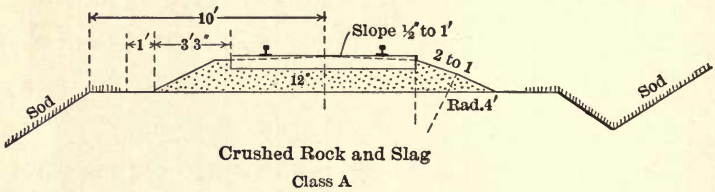
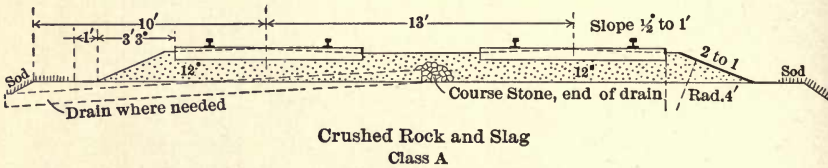

Fig. 5. Ballast Sections.

Grading.— Grading includes all excavation and embankments for the formation of the roadbed, all diversions of roads and streams, all borrow pits and ditches and similar work connected with and incident to the construction of the roadbed.

The material excavated is classified usually as “Common Excavation,” “Loose Rock,” “Solid Rock,” and measurement and payment are by units of one cubic yard, measurement made in excavation only, and by any method.

Approximate cost.	Actual cost.
Common excavation, 20 to 30 cts.
Loose rock, 60 cts. to \$1.
Solid Rock, \$1.60 to \$2.50

Overhaul.— When the distance of handling material exceeds a certain limit an extra is sometimes allowed under an overhaul clause. Usually 500 feet is designated as the limit of free haul, and any haul exceeding 500 feet is paid for at the specified price per cubic yard per station.

Average cost overhaul .01 to .02 cent per cubic yard (100 ft.).

Actual cost: —

Tile Drains.— Sub-drains of tile are used chiefly in cuts where it is difficult to get a proper ditch, or where the ditch fills up with sliding material. It is laid 2½ to 4 feet deep with a fall where practicable. Tile drains are made in one and two foot lengths. 3 to 6 inches diameter are the sizes generally used. Water enters the drains through the joints. Measurement and payment are by unit price per lineal foot, including excavation and refilling.

Approximate cost.	Actual cost.
3" tile, 12 to 15 cts. per lineal foot in place
4" tile, 13½ to 18 cts. per lineal foot in place
6" tile, 15 to 20 cts. per lineal foot in place

Crosswaying.— Crosswaying when required in swamps or muskegs is built of logs the full width of the embankment and

Add your own prices and records in blank spaces.

projecting beyond if desired, logs not less than 6 inches in diameter, small end, made up if necessary in one or two layers crossing each other at right angles placed close together and covered with brush. Measurement and payment are by units of 100 feet square.

Approximate cost. — \$30 to \$50 per 100 feet square.

Actual cost: —

Clearing. — Consists of clearing the right of way of all trees, logs, brush and other perishable matter, and burning or otherwise disposing of the same off the Company's property, stumps to be cut off even with the ground when the filling over them exceeds two feet. The last item is generally termed "close cutting." Measurement of clearing and payment for same are paid for by the acre or by units of 100 feet square actually cleared.

Approximate cost. — \$40 to \$60 per acre or \$10 to \$15 per 100 feet square.

Actual cost: —

Trees. — Dangerous trees outside right of way considered unsafe are paid for at a specified rate per tree removed.

Approximate cost. — 75 cts. to \$1 each.

All trees reserved for construction purposes are usually stripped and neatly piled. Payment for this service is usually by the cord of 128 cubic feet.

Actual Cost: —

Grubbing. — Grubbing consists in removing stumps and large roots where excavations occur, including ground from which material is to be borrowed, and from all ditches, drains, new channels for waterways and other places, and all ground to be covered by fill of less than 2 feet. Measurement of grubbing and payment are paid by the station of 100 feet or by units of 100 feet square actually grubbed.

Approximate cost. — \$20 to \$30 per 100 feet square.

Actual cost: —

Add your own prices and records in blank spaces.

Turnouts, etc.

The arrangement by which an engine and train pass from one track to the other is termed a turnout, and consists of a switch, frog, guards and lead rails. (Fig. 6.)

A train approaching so as to pass the switch point first is said to "face" the switch, and when it approaches in the opposite direction, passing the frog first, it is said to "trail" the switch.

Switches.—The switches in common use for turnouts are the stub and split or point switch. If the ends of the rails are cut off at a bevel, so as to lap slightly when thrown, it is called a lap switch. The split switch is practically universal as a standard, and generally is 15 feet and 16½ feet long, or half a rail length, for frogs 1 in 5 up to 1 in 12.

Split Switch.—The switch rail is slightly elevated above the stock rail by means of plates with risers, and is one-half to three-fourths inch below stock rail at the point, and one-fourth inch or so above stock rail 5 or 6 feet from the point. The distance which the switch point rail moves when the switch is thrown varies from 4 to 5 inches, and two to four tie bars either fixed or adjustable are used to connect the switch rails.

Fixed end of switch is called the heel.

Movable end the toe.

Stub Switch heel is farthest from the frog.

Split Switch heel is nearest the frog.

Toe of Split Switch is the point of switch.

Toe to heel is the length of switch.

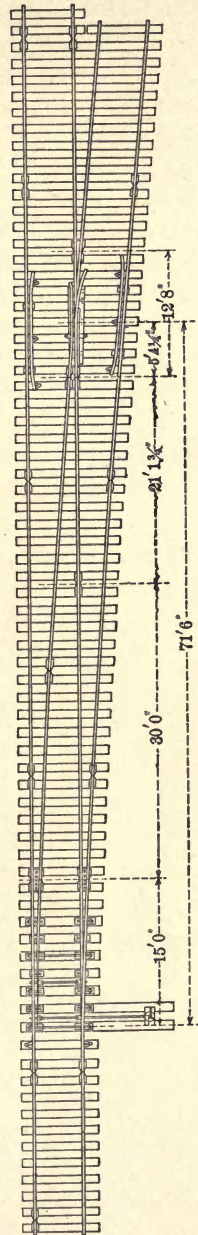

Fig. 6. Split Switch Turnout.

The throw is the distance over which the free end moves when thrown.

Turnout between switch and frog is usually made a simple circular curve.

Stub Switch. — The ordinary stub switch breaks the continuity of the main line in three places, two at the switch head block and one at the frog. Owing to the pounding of wheels over the open space, account settlement of head block, and to expansion and contraction of rail, rendering the joints tight in summer and open in winter, and the liability of derailment should a train trail the switch, their use has been practically abandoned except in isolated tracks in yards or at points seldom in service.

Slip Switches. — Slip switches are used where space is insufficient for ordinary turnouts or crossovers. Single slip is used when only one crossover track is required, double slips when two crossovers are necessary. (Fig. 11.) The switches are operated simultaneously from a central "slip switch stand." Each end of a slip has a special twin split switch, which forms the entrance to the crossovers, each crossover containing one right and one left turnout.

Switch Stands. — Automatic and rigid switch stands are used generally; for main line track switches the rigid type is principally used.

Frogs. — The frog is a device whereby the rail at the turnout curve crosses the main track rail, and is represented by Fig. 7, with all the parts designated in the terms generally used in ordering the various items, either bolted, clamped or riveted, rigid or spring rail.

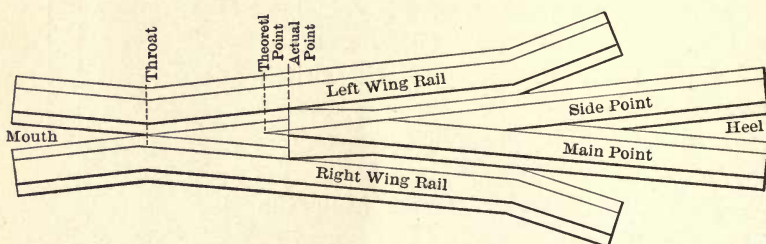

Fig. 7. Rigid Frog.

The bolted type of frog is generally used, with spring rail frogs for main line turnouts where siding traffic is relatively small.

Main line frogs are usually 9 to 12 and for yards 6 to 9, width of flangeways for frogs and guard rails $1\frac{3}{4}$ to $1\frac{7}{8}$ inches.

Foot guards are used in the angle of frogs, heel of switches and ends of guard rails to protect employees from getting their feet caught.

The frog number is the proportion of its length into its breadth or spread. Frog angle = $cb \div (ab + cd)$.

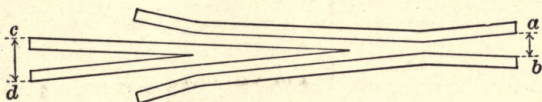

Fig. 8.

Example. — $ab = 4$ inches, $cd = 8$ inches, $bc = 84$. $84 \div (8 \text{ inches} + 4 \text{ inches}) = 7$. Angle or spread of frog is 1 in 7, or No. 7 frog.

TABLE FOR PUTTING IN FROGS AND SWITCHES.

— 4-8½ Gauge 5" Throw.

Number of frog.	Length of frog. Ft.	Angle of frog.	Radius of curve. Ft.	Split switch leads distance AB for 15 ft. Points.
5	5	11° 25'	239	50.
6	6	9° 32'	345	55.6
7	7	8° 10'	431	60.3
8	8	7° 10'	606	67.1
9	9	6° 21'	764	71.6
10	10	5° 44'	919	76.9
11	11	5° 12'	1096	80.0
12	12	4° 46'	1246	87.1

The split switch lead on tangents is the distance from the switch point to the frog point measured along the straight track.

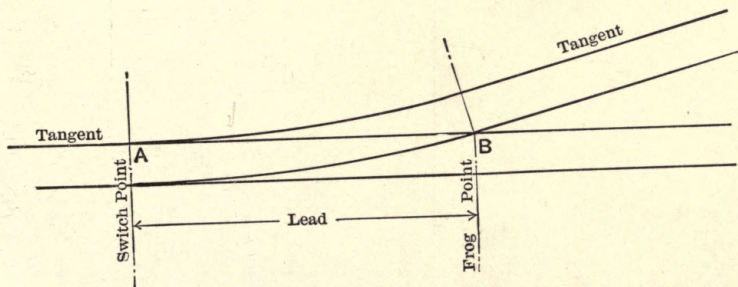

Fig. 9.

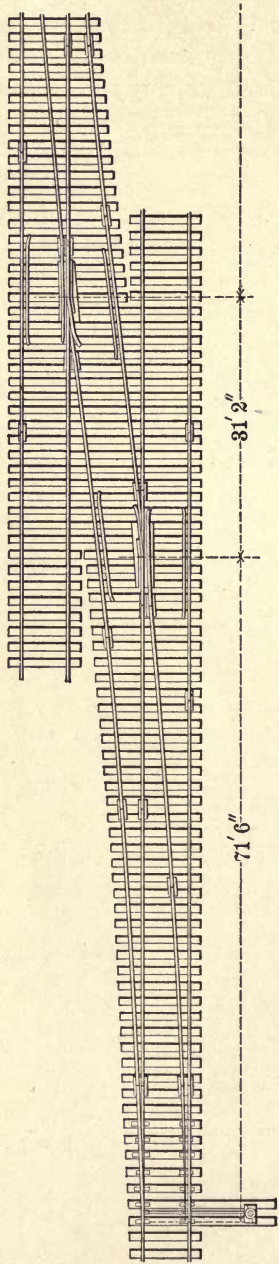

Fig. 10. Crossover.

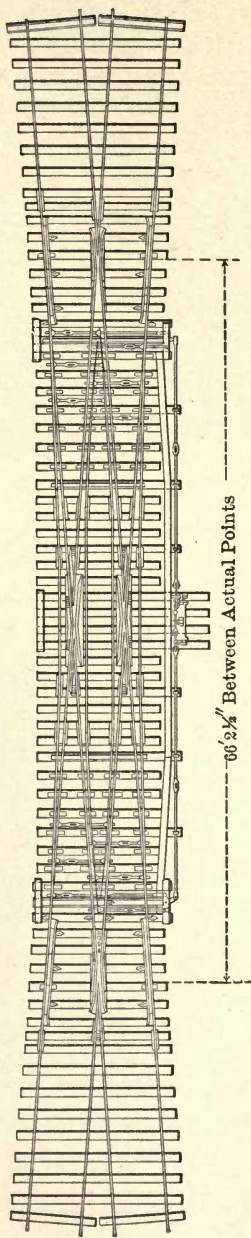

Fig. 11. Double Slip Switch.

Crossovers. — The arrangement connecting two parallel tracks is called a crossover and consists of a double turnout. (Fig. 10.)

To find the distance between frog points:

From the distance between gauge lines of parallel tracks subtract the gauge of track; multiply the remainder by the number of frog.

Example. — Distance between gauge line is 8 feet; gauge line 4 feet 8½ inches and No. 9 frog. 8 feet — 4 feet 8½ inches = 3 feet 3½ inches, which multiplied by 9 = 29 feet 7½ inches, the distance between frog points.

TABLE 8. — AVERAGE COST OF TURNOUTS INSTALLED COMPLETE (WITHOUT LEAD RAILS).

Name.	Kind.	Switch ties.	Switch stands, rods, lamps, etc.	Frogs with guards.	Laying and surfacing.	Total cost installed.
80 lb. split switch	Spring	\$100.00	\$30.00	\$60.00	\$50.00	\$240.00
80 lb. split switch	Rigid	100.00	25.00	50.00	50.00	225.00
60 lb. stub switch	Yard	85.00	25.00	50.00	40.00	200.00
80 lb. slip switch	Single	150.00	50.00	75.00	75.00	350.00
80 lb. slip switch	Double	200.00	90.00	140.00	125.00	550.00

TABLE 9. — DETAILS OF COST.

Switch ties.	Approximate cost.	Actual cost.
1 set for main line switch.....	\$80.00 to \$125.00
1 set for yard switch.....	70.00 to 100.00
1 set stub switch ties.....	65.00 to 95.00
1 set yard switch ties.....	55.00 to 80.00
1 set slip switch, single.....	125.00 to 150.00
1 set slip switch, double.....	150.00 to 200.00

Add your own prices and records in blank spaces.

TABLE 9. — DETAILS OF COST. (Continued.)

For bill of switch ties, see p. 24.

Switches.	Approximate cost.	Actual cost.
New stub switch.....	\$20.00 to \$30.00
New main line split.....	30.00 to 50.00
New main line slip switch (single)..	40.00 to 60.00
New main line slip switch (double)	50.00 to 80.00

Frogs.	Approximate cost.	Actual cost.
1 80-lb. spring frog, \$50, with guard rails.....	\$62.00.
1 80-lb. rigid frog, \$38, with guard rails.....	52.00
1 60-lb. spring frog, \$35, with guard rails.....	47.00
1 60-lb. rigid, \$14.25, with guard rails.....	21.00
1 72-lb. rigid, \$16, with guard rails.	23.00
1 56-lb. rigid, \$14, with guard rails	21.00

Stands, lamps, rods, etc.	Approximate cost.	Actual cost.
Split switch stands:		
Automatic.....	\$12.00 to \$15.00
High.....	18.00 to 20.00
Intermediate.....	15.00 to 17.00
Low.....	9.00 to 12.00
Ramapo stub switch stand.....	8.00 to 12.00
Lamps.....	4.00 to 5.00
Lock and chain.....	.50 to .75
Head chain (2).....	\$3 at 3½ cts. per lb.
Tie rods (6).....	\$9 at 3 cts. per lb.
Tie plates or rail braces 15 cts. each.	\$2.70 per turnout

TABLE 9. — DETAILS OF COST. (Concluded)

Laying and surfacing.	Approximate cost.	Actual cost.
Stub switch.....	\$25.00 to \$35.00
Main line switch (split).....	30.00 to 50.00
Switches in large yards.....	30.00 to 40.00
Taking up and relaying switch....	30.00 to 50.00
Slip switch, single.....	50.00 to 70.00
Slip switch, double.....	60.00 to 100.00

TABLE 10.

Crossover.	Approximate cost.	Actual cost.
2 turnouts.....	\$250.00
170 ft. 80-lb. rail.....	115.00
Fastenings.....	18.00
Ties.....	10.00
2 sets switch ties at \$113.50.....	227.00
Labor.....	80.00
Total.....	\$700.00

Notes : —

.....

.....

.....

.....

Add your own prices and records in blank spaces.



Switch Ties.—Switch ties are usually oak or best local hardwood, 7 inches thick and 9 inches wide, ends sawed square.

TABLE 10A. — BILL OF SWITCH TIES FOR 15-FOOT SPLIT SWITCH TURNOUTS.

All Ties 7" × 9".

Length.		No. 7. No.	No. 8. No.	No. 9. No.	No. 10. No.	No. 11. No.	No. 12. No.
Ft.	In.						
8	0	5	5	5	5	5	5
8	3	3	3	3	3	3	3
8	6	3	3	3	3	3	3
8	9	3	3	3	3	3	3
9	0	3	3	3	3	3	4
9	3	2	3	3	3	3	3
9	6	2	1	2	2	3	3
9	9	1	2	2	2	3	3
10	0	1	1	2	2	3	3
10	3	1	2	2	3	1	2
10	6	1	1	2	2	2	2
10	9	1	2	2	2	2	1
11	0	1	1	1	2	2	2
11	3	1	1	2	2	2	1
11	6	1	1	1	1	2	2
11	9	1	1	1	2	1	2
12	0	1	1	1	1	3	2
12	3	2	2	2	1	1	1
12	6	2	2	1	2	2	2
12	9	1	1	1	2	1	2
13	0	1	2	1	1	2	1
13	3	1	1	2	2	1	2
13	6	2	1	2	1	2	1
13	9	1	1	1	1	1	1
14	0	1	1	1	2	2	3
14	3	1	2	1	2	2	2
14	6	1	1	2	1	2	2
14	9	1	1	1	1	2	1
15	0	1	1	1	2	1	1
15	3	1	1	1	1	1	2
15	6	1	1	1	1	1	1
15	9	1	1	1	1	1	1
16	Headblock	2	2	2	2	2	2
Total		50	55	59	64	68	69
Lineal ft.		555½	614½	657	718½	765½	776½
Feet B. M.		2918	3225	3449	3771	4019	4077

Crossing.

Complete Diamond installed, \$250 to \$350.

.....

.....

Interlocking Plant.

For an ordinary single track interlocked crossing at grade.

8-Lever Machine including house and signals, \$4500 to \$5500.

16-Lever Machine including house and signals, \$7500 to \$8500,
or an approximate price for estimating \$500 per lever.

MAINTENANCE OF INTERLOCKING PLANT PER ANNUM.

2 men at \$1.25 per day	\$913.00
Inspection, \$3 per month.....	36.00
Repairs and materials, \$20 per month.....	240.00
40 gallons oil at 20 cts., \$8 per month.....	96.00
Lamps, wicks and chimneys, \$1 per month.....	12.00
	\$1297.00

The above if capitalized at 5 per cent would be equivalent to an expenditure of \$25,940.00.

Notes : —

.....

.....

.....

Add your own prices and records in blank spaces.

CHAPTER II.

FENCES, GATES, SIGN POSTS, ROAD CROSSINGS AND GUARDS.

Fences.

FOR fencing in the right of way each railroad usually has its own standard.

Wire Fence. — The ordinary fence consists of hard galvanized iron coiled wires, made in five to seven strands, spaced from 5 to 10 inches apart, the fence averaging about 4 feet high, reinforced with verticals at varying distances. Wood fence posts are placed from 17 to 33 feet apart, set about 5 feet above ground and 3 feet under.

The fences are either woven or field-erected, the woven being used on fairly level ground, and the field-erected on rough and uneven ground. Cross braces of 4" × 4" timbers and wire are used at end panels to stiffen the fence lengthwise. (Fig. 12.)

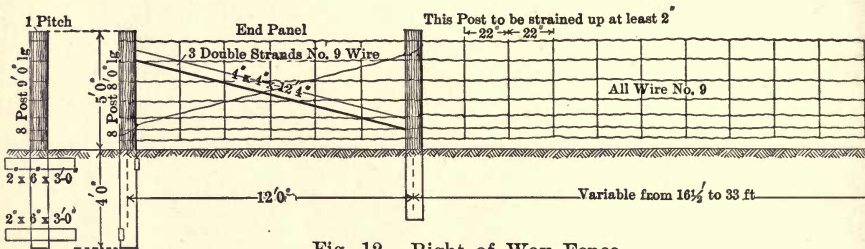

Fig. 12. Right of Way Fence.

TABLE 11.

Fencing per mile of track, erected complete.	Approximate cost.	Actual cost.
7-strand 48-in. woven-wire fence....	\$270.00 to \$300.00
5-strand 42-in. woven-wire fence....	216.00 to 230.00
7-strand 48-in. field-erected fence...	320.00 to 400.00
5-strand 42-in. field-erected fence...	282.00 to 325.00

FENCES.

Approximate estimates of cost. —

7-strand 48-in. woven-wire fence, 25 cts. per rod (16½ ft.)	\$80.00
Posts 9 cts. each, erection 5 cts. (160 per mile)	22.40
Erection of fence	32.60
	<hr/>
One side	\$135.00
	<hr/>
Per mile of track	\$270.00

.....

5-strand 42-in. woven-wire fence, 18 cts. per rod (16½ ft.)	\$57.60
Posts 9 cts., erection 5 cts. (160 per mile)	22.40
Erection of fence	28.00
	<hr/>
One side	\$108.00
	<hr/>
Per mile of track	\$216.00

.....

7-strand 48-in. field-erected wire fence, 29 cts. per rod	\$92.80
Posts 9 cts. each, erection 5 cts. (160 per mile)	22.40
Erection	44.80
	<hr/>
One side	\$160.00
	<hr/>
Per mile of track	\$320.00

5-strand 48-in. field-erected wire fence, 27 cts. per rod (16½ ft.)	\$86.40
Posts 9 cts. each, erection 5 cts. (160 per mile)	22.40
Erection	32.20
	<hr/>
One side	\$141.00
	<hr/>
Per-mile of track	\$282.00

.....

Add your own prices and records in blank spaces.

Picket Fence. — The ordinary picket fence for use in yard shops, etc., consists of 8-inch cedar posts 9 to 10 feet long, set 6 feet above ground and 3 to 4 feet under, at about 8-foot centers, with 3" × 4" runners top and bottom, set about 12 to 18 inches from ground and top of posts; to these are nailed 4" × 1" × 6' vertical pointed end pickets, with spaces between varying from 1 inch to 6 inches.

Approximate cost per linear foot, 50 to 75 cents.

.....

Wood Snow Fences. — Snow fences are used in open country to prevent or minimize trouble from drifting snow blocking the track. They are usually of wood, though tree and hedge fences and earth banks are in use.

When permanent, a close or open board fence is erected on the portion of the right of way affected, 30 to 50 feet from track. When located off the right of way, permission is usually obtained from the farmers, and portable fences are used and placed 150 feet or more from the track.

Kind.	Approximate Cost.	Actual Cost.
Permanent close board fence per lin. ft. .	50 to 60 cts.
Permanent open board fence per lin. ft. .	40 to 50 cts.
Portable fence per lin. ft.....	30 to 40 cts.

Permanent Close Board Fence. — Cedar posts 8 inches diameter by 12 feet long, placed 8-foot centers, standing about 8 feet 6 inches from ground line, and covered with 7/8-inch boards to within one foot of ground with 1" × 6" cover piece over the joints at each post.

Add your own prices and records in blank spaces.

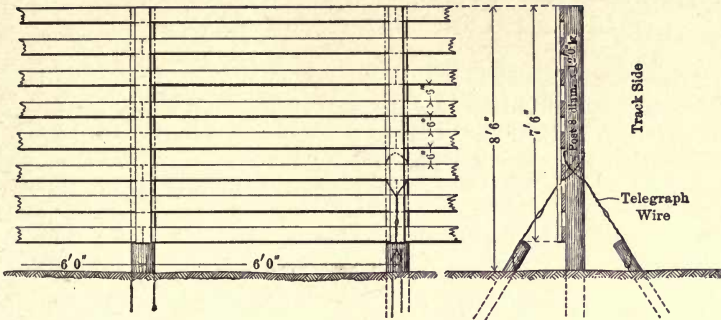

Fig. 13. Permanent Snow Fence. (Open Board.)

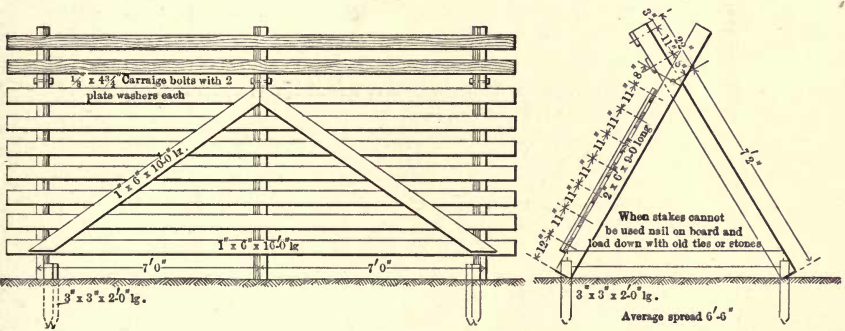

Fig. 14. Portable Snow Fence.

Permanent Open Board Fence. (Fig. 13.) — Similar to the close board fencing excepting that the boards are placed with 6-inch spaces between.

Portable Fence. (Fig. 14.) — Made in sections 14 and 16 feet long, with triangular shaped supports 6 to 8 feet high, and about 6 feet spread, with 2" x 6" inclined main supports at 7-foot centers, and 2" x 6" brace behind; when not held down by stakes to ground, 2" x 6" ties are used at the bottom of frame and stone piled on top.

The boards are 3/4-inch material from 6 to 8 inches wide, about 12-inch centers with 4 to 6-inch spaces between.

Approximate estimate of cost.

PERMANENT CLOSE BOARD FENCING.

One 16-foot Panel.

2 fence post holes at 35 cts.....	\$0.70
2 posts 8 inch-diameter, 12 feet long, at 9 cts.....	2.16
150 feet B. M. boarding at \$35.....	5.25
3½ pounds 12d. steel nails at 8 cts.....	0.28
2 stake posts 6-inch diameter, 5 feet long, each at 25 cts....	0.50
16 feet galvanized iron guy wire.....	0.11
Total, p. panel.....	<u>\$9.00</u>

PERMANENT OPEN BOARD FENCE.

One 16-foot Panel.

2 fence post holes at 35 cts.....	\$0.70
2 posts 8-inch diameter, 12 feet long, at 9 cts.....	2.16
97 feet B. M. boarding at \$35.....	3.40
1½ pounds nails at 8 cts.....	0.13
2 stake posts 6 to 8 inches diameter, 5 feet long, each 25 cts.	0.50
16 feet galvanized iron wire.....	0.11
Total, p. panel.....	<u>\$7.00</u>

PORTABLE FENCE.

One 14-foot Panel.

150 feet B. M. timber at \$35.....	\$5.25
3 pounds nails at 8 cts.....	0.24
3½"×4½" carriage bolts with washers.....	0.31
Ground stakes or bottom ties.....	0.20
Total, p. panel.....	<u>\$6.00</u>

Safety Crossing Gates.

At public road grade crossings it is sometimes necessary to place safety gates, consisting of iron posts placed at the curb of roadway parallel with track to which are connected the main and sidewalk arms, usually of wood, that stretch over and protect the crossing. They are operated by hand crank at gate level, or by hand lever or compressed air from a tower (sometimes a number of crossings are operated from the one tower), arranged so that the gates cannot be opened or closed excepting

Add your own prices and records in blank spaces.

by the operator. The connections for operating the gates simultaneously are either placed underground or overhead as desired.

The gates are usually located 8 to 10 feet clear of the nearest rail, with the elevated tower on one side or between tracks when convenient.

The span of gates varies to suit conditions. They are made usually in two-post or four-post crank, lever, or pneumatic types, the two-post style being used when the road is not too wide, and four-post construction for large openings. The smaller the span, other things being equal, the easier will the gates be operated.

TABLE 12. — SAFETY GATES.

Kind.	Approximate Cost.	Actual Cost.
Two-post crank gates with watchman's shanty complete.....	\$300.00 to \$400.00
Four-post crank gates with watchman's shanty complete.....	400.00 to 500.00
Two-post lever gates with wood tower and connections complete..	450.00 to 650.00
Four-post lever gates with wood tower and connections complete..	600.00 to 800.00
Two-post pneumatic gates with wood tower and connections complete	500.00 to 700.00
Four-post pneumatic gates with wood tower and connections complete.....	700.00 to 900.00

The above prices are for wood foundation throughout.

Two-post crank gate would consist of —

- One cast-iron power or crank post,
- One cast-iron dead post,
- Two bifurcated wooden main and sidewalk arms,
- Two shafts,
- Piping, wood or concrete foundations,
- Watchman's shanty and bells if desired.

A four-post crank gate, excepting for the first and last items, would be double the above.

Add your own prices and records in blank spaces.

Two-post lever gate would consist of —

Elevated tower with posts and foundations,
Two cast-iron posts,
Two bifurcated wooden main and sidewalk arms,
One lever stand with two levers,
Chain and rod connections,
Gatepost foundations and ducts,
Installation,
Bells for arms and tower if desired.

A four-post lever gate would be double the above excepting the first and last items.

Two-post pneumatic gate would consist of —

Elevated tower with posts and foundations;
Two cast-iron posts with locking connections,
Two bifurcated wooden main and sidewalk arms,
One air-pump and valves (unless air can be supplied),
Piping and connections,
Gatepost foundations and ducts,
Installation,
Bells for arms and tower if desired.

A four-post pneumatic gate would be double the above excepting the air-pump and first and last items.

The elevated tower for crossing gates would cost from \$150 to \$200 each.

Generally speaking the lever crossing gate is more positive in action than the pneumatic type; the pneumatic type under certain conditions is not always satisfactory.

Farm Crossing Gates. — Generally made of wood and wire, or gas pipe and wire, the last mentioned being known as the steel gate.

Usually 14 and 16 feet long, standing 4 feet 6 inches above ground 4 feet high, made to swing outward away from track.

Kind.	Approx. Cost.	Actual Cost.
Swing wire gate with wooden frame complete 14 ft. long (Fig. 16).....	\$3.75 to \$4.50
Swing wire gate with steel frame complete 14 ft. long (Fig. 17).....	4.50 to 5.50
Swing board gate, board frame 16 ft. long (Fig. 15).....	4.00 to 5.00
Swing wire gate, steel frame 16 ft long (Fig. 17).....	5.00 to 6.00

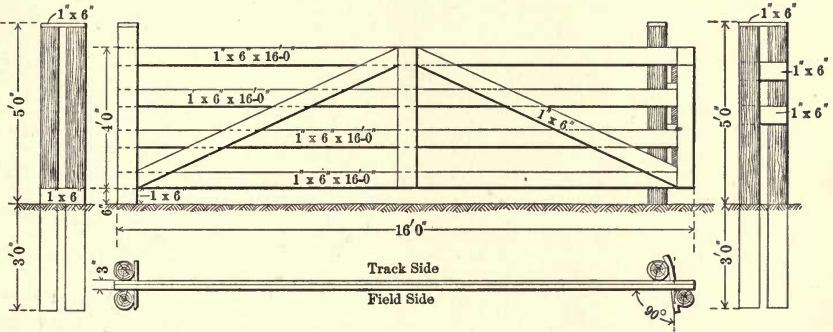

Fig. 15. Swing Board Gate.

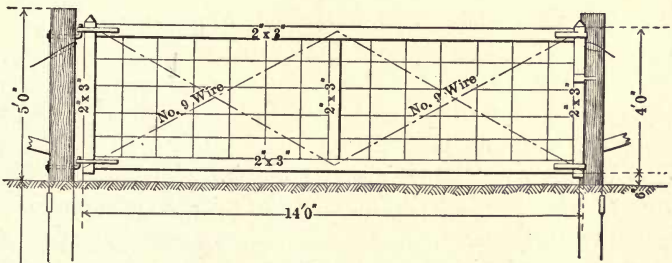

Fig. 16. Swing Wire Gate.

Wooden Gates. (Figs. 15 and 16.)—The wooden gates are usually made of 2" × 3" frame all round with a 2" × 3" post in center

Add your own prices and records in blank spaces.

and No. 9 galvanized wire mesh over, with two diagonal cross-wire ties.

The wooden swing board gate is made up of four 1" \times 6" \times 16' planks with 8-inch spaces between having one center and two diagonal planks 1" \times 6".

Steel Gates. (Fig. 17.) — The steel pipe gates are made with $1\frac{1}{2}$ -inch steel pipe, divided into three equal panels with two vertical $1\frac{1}{2}$ -inch bars between, covered with No. 9 galvanized iron wire mesh with diagonal wire brace.

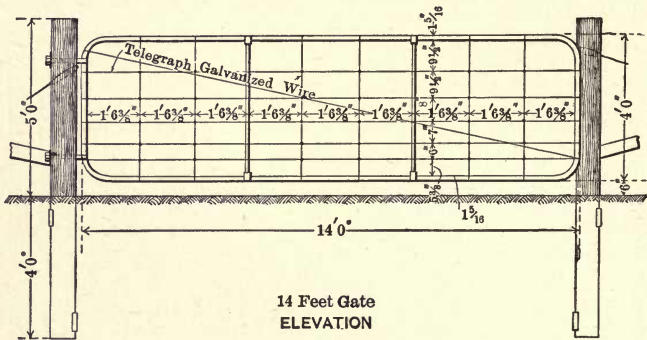

Fig. 17.

Highway Crossing Alarm Bell. — At highway crossings where traffic does not warrant a watchman or safety gates, an electric alarm bell attached to the road-crossing sign, or erected on a special iron or wood pole, is often used, arranged so as to ring ahead of an approaching train; a light also is sometimes provided above the bell. The track rail joints are bonded for a distance of 1000 to 3000 feet on either side the crossing and insulated for battery and bell circuit, a battery being necessary at each end of the bonded track and one at foot of bell post.

The approximate cost of alarm bell erected complete, \$300 to \$400.

When a light is installed, the cost is increased 25 to 50 per cent.

General Signboards and Posts.

Approximate cost, etc., of various signboards and posts usually erected on the right of way, from C. P. R. Standards, F. P. Gutelius, Assistant Chief Engineer.

Railway Crossing and Highway Sign. — Placed at all public road grade crossings facing the approach. Post 7 to 9 inches round, about 12 feet above top of rail, set into ground about 4 feet, two 8-inch planks on top placed crosswise with the words "Railroad Crossing" marked in plain block letters 6 inches high on each side.

Approximate cost complete, \$4.00 to 5.00.

Actual cost: —

Railway Crossing, Railway Junction and Drawbridge Sign. — Post 7 to 9 inches round, about 10 feet 6 inches above top of rail and 5 feet in ground, with four boards on top placed diamond shape with the words "Railway Crossing One Mile" in plain block letters 6 inches high, or "Drawbridge Crossing" or "Junction Crossing" in place of "Railway Crossing."

Approximate cost complete, \$3.50 to \$4.50.

Actual cost: —

Wing Post Sign. — Placed 8 feet from rail and 150 feet from obstructions where wings of snow plows must be closed and points lifted. Post 4 to 6 inches round, about 7 feet above rail and 3 to 4 feet in ground, with two boards placed crosswise at the top with a round black disk painted in each corner.

Approximate cost complete, \$1.00 to \$1.25.

Actual cost: —

Flanger Post. — Placed 8 feet from rail, and 150 feet from obstructions where points and flangers must be lifted. Post 4 to 6 inches round, 7 feet 6 inches above rail set 3 feet 6 inches below ground, with 8" × 2' board on top, having two round black disks, one on each side.

Approximate cost complete, \$1.00 to \$1.25.

Actual cost: —

Add your own prices and records in blank spaces.

Station Mile Board. — Placed 10 feet from rail, 6 to 8 inches round, post about 9 feet above rail and set in ground 4 feet, with board 12 to 15 inches wide 5 feet long, with "Name of Station" and 1 mile under in plain block letters.

Approximate cost complete, \$2.00 to \$2.50.

Actual cost: —

Yard Limit. — 6 to 8-inch round post about 9 feet above rail and about 4 feet in ground, with board placed on top and "Yard Limit" marked in plain block letters.

Approximate cost complete, \$2.00 to \$2.25.

Actual cost: —

Section Post. — Placed 7 feet from rail. 4"×4" square post standing 5 feet above rail and set 3 feet in ground with 10"×18" board on top, with the two section numbers marked.

Approximate cost complete, \$0.90 to \$1.00.

Actual cost: —

Mile Post. — Placed 7 feet from rail. 10"×10" square post set diamond fashion to the track, about 5 feet above rail, and set 3 feet 6 inches in ground; about the top of the post the mile number is painted on the two sides facing the track.

Approximate cost complete, \$2.00 to \$2.50.

Actual cost: —

Mile Board. — Attached to telegraph pole about 10 feet above ground. A 10"×3' board with the mile painted on each side, and attached to the nearest telegraph pole.

Approximate cost complete, 30 to 50 cents.

Actual cost: —

Whistle Post. — Placed 7 feet from rail and one-fourth mile from public road crossings. A flat board 3"×9" standing 5 feet above rail, and set 3 feet in ground; the letter "W" is painted at the top.

Approximate cost complete, 75 to 90 cents.

Actual cost: —

Add your own prices and records in blank spaces.

Trestle Number.— Placed in center of structure on milepost side. 12"×36" board with the trestle number painted on in plain block letters, and bolted to one of the ties outside of the guard.

Approximate cost complete, 35 to 45 cents.

Actual cost: —

Culvert Number.— 4"×4" square post standing 6 feet above ground, 8 feet from rail, with 9"×24" board having the Culvert number painted on in plain block letters.

Approximate cost complete, 80 to 90 cents.

Actual cost: —

Trespass Sign.— Six-inch round post standing 5 to 6 feet above the rail and about 4 feet in ground, with 18"×30" board on top, having the words "Caution" "Do not trespass" painted in plain block letters.

Approximate cost complete, \$1.50 to \$1.80.

Actual cost: —

Clearance Post.— 4"×4" post standing about 9 inches high above rail set 2 feet into ground with chamfered top painted black with the lower portion white placed at extreme clearance points of sidings.

Approximate cost complete, 40 to 50 cents.

Actual cost: —

Elevation Posts.— 4"×4" posts standing about level with top of rail, placed on the outside of, and at the beginning and end of curves and spirals about 6 feet from outside rail, with the letter **E** and **O** under facing tangent, and **G** and **O** under facing track, on tangent end of spirals, and the letter **E** with elevation under, facing spiral curve, and **G** with excess gauge marked under, facing track, and **D** with degree of curve under, facing circular curve.

Approximate cost complete, 40 to 50 cents.

Actual cost: —

Add your own prices and records in blank spaces.

Rail Rack Posts. — 6"×15" posts made up of old stringers with three 5-inch steps at top, to hold spare rails; posts are set 18 feet apart 7 feet from rail, and set about 3 feet in ground.

Approximate cost complete, 75 cents to \$1.00 per pair.

Actual cost: —

Stop Signal Post Sign. — Used where trains must come to a full stop, at railway crossings, etc., placed 400 feet on each side and 8 feet from rail. Six-inch round post standing about 8 feet above rail with chamfered end, set about 4 feet in ground, with tapered board 8"×3' about 12 inches from top, and the word "Stop" painted on in plain block letters.

Approximate cost complete, \$2.00 to \$2.25 each.

Actual cost: —

Slow Signal Post Sign. — Used where all trains must be under full control, placed 2000 feet from points protected and 8 feet from rail. Post similar to stop signal post sign, tapered board 8"×3' with V-shaped end, and the word "Slow" painted on in plain block letters.

Approximate cost complete, \$2.00 to \$2.25 each.

Actual cost: —

Bridge Warning. — Placed over the track 100 feet or thereabouts from all overhead obstructions less than 22 feet 6 inches clear height above top of rail. 8 by 8 post standing about 26 feet above rail and about 5 feet in ground with 6"×6" horizontal arm on top 13 feet long, fastened to post with iron strap and 6 by 6 brace; from the arm are suspended sixteen $\frac{3}{8}$ -inch sash cords 3 feet 6 inches long each, well bound at the bottom and looped to one-half inch by 2-foot long double eye bolts, hooked to screw eye bolts fastened to the horizontal bar.

Approximate cost complete, \$15.00 to \$18.00.

Actual cost: —

Add your own prices and records in blank spaces.

Mail Crane.

Mail cranes are erected at way stations where necessary to collect the mail while the train is running.

The main post, either of wood or steel, is set up about 10 feet from center of track, and attached with a blocking piece to two extra long track ties, the post being stayed at the back by a double brace.

At the top of the post about three-foot centers two horizontal arms project 3 feet towards the track arranged to hold the mail bag. The arms have a steel spring attachment at the post end so that when the bag is released they automatically rise and fall towards the post, one going up and the other down.

A light iron ladder is placed for convenience of the operator, so that he may be able to catch the arms and tie the mail bag in position.

Approximate cost of an iron mail crane complete, \$25 to \$50.

Actual cost: —

Grade Road Crossings.

At grade crossings of public and farm roads it is necessary to make a driveway for the safe passage of vehicles over the track, for a width of 12 to 16 feet for farms, and 20 feet or over for public crossings. Three-inch plank is generally used of varying widths, and of the desired length, placed fairly close together between rails and one on the outer side of each rail, spiked to 2-inch shims under the planks and secured to the ties; the height of shims is made to suit the rail, and the ends of planks are usually chamfered off, and in some cases a rail is placed on its side, butting against the web of the main track rails with the base against the plank to form a flangeway.

In some cases a wooden frame is made and filled with gravel or cinders at about the same cost. This form is not recommended, as heavy loads may cause the wheels to sink into the filling when teams are passing over, and is likely to cause trouble.

Add your own prices and records in blank spaces.

Kind.	Approximate cost, Single Track Cross- ings.	Actual Cost.
12-foot wide plank crossing.....	\$ 7.00 to \$10.00
16-foot wide plank crossing.....	10.00 to 15.00
20-foot wide plank crossing.....	15.00 to 20.00
24-foot wide plank crossing.....	20.00 to 25.00

Overhead Farm Crossings. — The overhead farm crossing is in the nature of a light highway bridge, and generally has to be designed to suit the varying conditions of ground actually met with. The bents are placed about 20 feet apart across the track for single, and 30 feet or more for double track, with a clear height of 22 feet 6 inches under the crossing, and a width of 14 feet or more. The balance of the bents are spaced 14 or 16-foot centers on either side of track. The floor joists up to 20-foot center to center of bents, may be 3"×12", and for double track 31 feet 6 inches centers to centers of bents 6"×14", at about 2-foot centers, covered with 3-inch plank; a railing 4 feet high or more is placed on each side of crossing made up of 4"×4" posts about 8-foot centers with 2"×3" brackets and 4"×4" hand rail secured to posts; the floor plank is made extra long at the posts to take the bracket, and 1"×4" fencing is used. The bents have 12"×12" caps on three cedar piles, or 10"×12" posts, three to a bent, with flatted cedar sill under and 12"×12" cap on top; the bents are cross braced from sill to cap with 3" by 10" plank, one on each side, and 3"×10" braces are also inserted longitudinally, at least one panel on each side of the track.

Approximate Cost. — \$8 to \$12 per lineal foot for 14-foot wide crossing.

Actual cost: —

Add your own prices and records in blank spaces.

Cattle Guards.

At public highways and other crossings cattle guards are placed on each side of the road, to prevent cattle from getting on the right of way.

They are made of various material, metal and wood being used principally. The metal guards are liable to rust unless frequently painted. The wood guards is the most popular.

Wood Cattle Guards. (Fig. 18.)—The common wood cattle guard consists of a number of board slats $1\frac{1}{4}'' \times 5'' \times 8'$ nailed at about 4-inch centers to slant face wood blocks, one block at each end between each slat, 10 slats with 18 blocks forming a

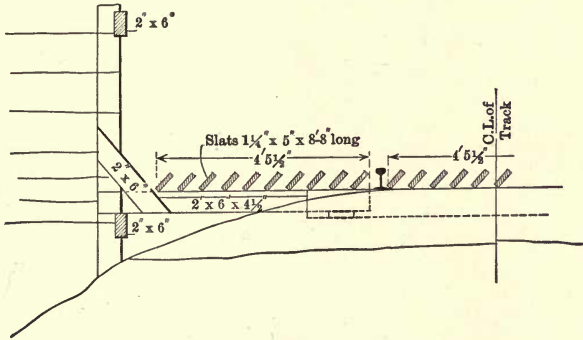

Fig. 18. Wood Cattle Guard.

section; three sections are generally used, one at each side and one in the center of track, and placed each side of road crossing resting on $2'' \times 6''$ timbers supported on 8-inch diameter cedar posts with small brace straps at the bottom and ends; the rest timbers are arranged to come about level with base of rail, so that the guard extends about 4 inches above the base of rail. The guards and fence posts are usually whitewashed when placed.

Approximate Cost. — Cost of wood cattle guards (6 sections) complete in place, \$15 to \$25.

Actual cost: —

Pit Guards. — The pit guard is usually an open culvert spanned by stringers to carry the track; their use for many reasons is not recommended.

Add your own prices and records in blank spaces.

Metal Guards. — Metal guards made with galvanized iron bent to form any desired type of cattle guard is usually made up in sections arranged to fasten to the track ties, the two outer sections being supported at the ends with 2"×6" timbers nailed to 8-inch cedar posts similar to the wood guard supports.

Approximate cost of galvanized iron cattle guards (6 sections) complete in place, \$25 to \$45.

Actual cost: —

Add your own prices and records in blank spaces.

CHAPTER III.

CULVERTS.

CULVERTS are used for conveying small streams under the road-bed and for drainage purposes. Tile, concrete, and cast-iron pipes are principally used, including masonry and timber boxes and concrete arches.

When pipes are used locate on solid ground high enough to clear when flow ceases, and lay on a uniform grade equal to that of the natural ground, with a camber when grade is less than one per cent to prevent formation of pockets by settlement. Preferably excavate trench to fit the bottom part; otherwise solidify by tamping and compacting carefully around the culvert.

Do not block, wedge, or lay in water. Place all sockets upgrade and begin from lower end.

Back fill in tamped layers. Do not tamp on top, but form an arch of tamped material over, leaving one diameter of loose material over the centers; then tamp all the way across.

When two or more are used side by side keep them one diameter apart.

When there is a liability to scour, end walls or sheet piling is provided.

When pile foundation is necessary use one row for small pipes and two rows staggered, for 24 inch or greater, supporting the entire length of pipe. Box or arch culverts are piled when necessary under the main walls.

Pipe Culverts.

TABLE 13. — LENGTH OF PIPE REQUIRED FOR DIFFERENT HEIGHTS OF EMBANKMENT.

Height, base of rail to invert. Length, pipe required in linear feet.

Height, ft ..	6	8	10	12	14	16	18	20	22	24	26	28	30
Length, ft..	30	36	42	48	54	60	66	72	78	84	90	96	102

Estimating Sizes of Pipe. — One-inch rain fall per acre gives approximately 24,000 gallons per hour, or 400 gallons per minute. Not more than 50 per cent to 75 per cent will reach drain within same hour.

TABLE 14. — APPROXIMATE CARRYING CAPACITY OF PIPES.

Inches fall to 100 feet.

Size of pipe.	2 in.	3 in.	6 in.	9 in.	12 in.	24 in.	36 in.
	Gallons discharged per minute.						
18 inches.....	2,000	2,500	3,500	4,500	5,000	7,000	8,500
24 inches.....	4,500	5,500	7,500	9,000	10,500	15,000	18,000
30 inches.....	8,000	9,500	13,500	16,500	19,000	26,500	32,500
36 inches.....	12,500	15,500	22,000	26,500	31,000	43,500	53,000

Make allowance for severe storms, which are generally of short duration.

Tile Pipe Culverts. (Fig. 19.) — Tile pipe must have at least 4 feet of embankment on top.

TABLE 15. — APPROXIMATE COST.

Inner diam.	Min. thickness shell.	Min. length laid.	Depth of socket.	Annual space.	Weight per lin. ft.	Approx. cost per ft.	Riprap walls for ends when required (Fig. 19) cu. yds.
In. 4	In. $\frac{1}{2}$	In. 24	In. 2	In. $\frac{1}{2}$	Lbs. 10	\$0.10
6	$\frac{5}{8}$	24	$2\frac{1}{2}$	$\frac{5}{8}$	16	.13 $\frac{1}{2}$
8	$\frac{3}{4}$	30	$2\frac{3}{4}$	$\frac{5}{8}$	25	.17 $\frac{1}{2}$
10	$\frac{7}{8}$	30	$2\frac{3}{4}$	$\frac{5}{8}$	37	.22
12	1	30	3	$\frac{5}{8}$	45	.27	8
15	$1\frac{1}{4}$	30	3	$\frac{5}{8}$	76	.46	9
18	$1\frac{1}{2}$	30	$3\frac{1}{4}$	$\frac{5}{8}$	118	.63	10
20	$1\frac{3}{8}$	30	$3\frac{1}{2}$	$\frac{5}{8}$	138	1.10	11
24	2	30	4	$\frac{5}{8}$	190	1.37	12

Excavating, laying, and refilling extra.

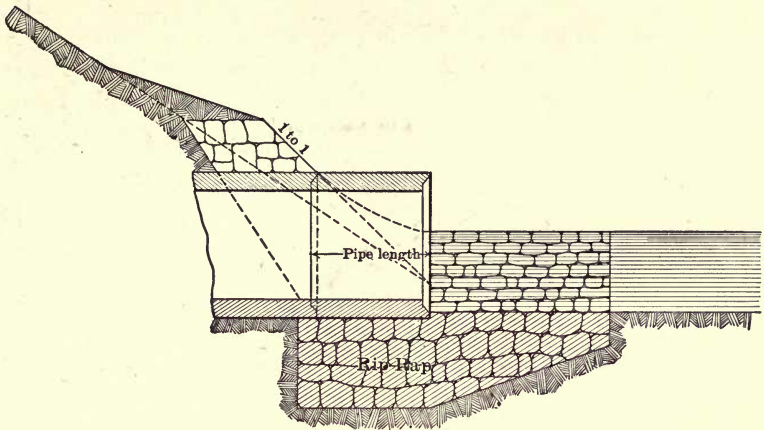

CROSS SECTION

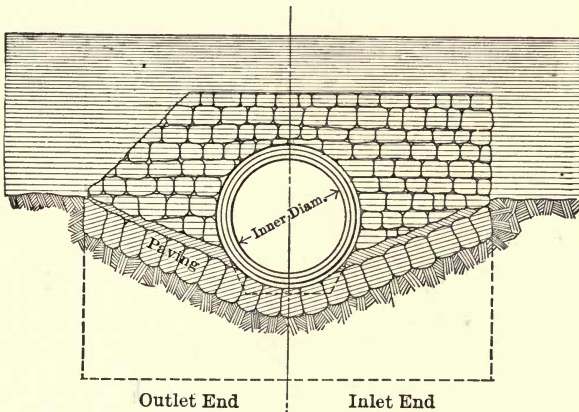

PIPE CULVERTS

Fig. 19.

Joints usually made of caulked oakum protected by cement mortar; when foundation is solid joints may be filled with cement mortar, one cement and one sand.

TABLE 16. — MORTAR FOR 100 JOINTS CONCRETE OR TILE PIPE.

18-inch diameter pipe	1 $\frac{1}{2}$ barrels cement	$\frac{1}{4}$ yard sand
24-inch diameter pipe	2 $\frac{1}{2}$ barrels cement	$\frac{1}{3}$ yard sand
30-inch diameter pipe	4 barrels cement	$\frac{1}{2}$ yard sand
36-inch diameter pipe	6 barrels cement	$\frac{3}{4}$ yard sand

Concrete Pipes. (Fig. 19.) — Concrete pipe must have at least 4 feet of embankment on top; a considerable saving may be effected in transportation by having the pipe made at or near the site, especially on new work.

TABLE 17. — APPROXIMATE COST.

Mixture: 1 cement, 2 sand, and 3 broken stone.

Inner diam. of pipe, in.	Pipe lengths.	Weight in lbs. at 130 per cu. ft.		Cu. ft. per lin. ft.	Thickness of pipe.	Approx. cost per lin. ft. at \$10.80 per cu. yd.	Rip-rap for end walls when reqd. (Fig. 19) cu. yds.
	Ft.	Per lin. ft.	Per length.				
18	3.0	150	450	1.15	$2\frac{5}{8}$	\$0.46	10
24	3.0	300	900	2.3	$3\frac{3}{4}$	0.92	12
30	2.6	430	1075	3.3	$4\frac{1}{2}$	1.32	14
36	2.5	550	1375	4.25	$5\frac{7}{16}$	1.70	16

Excavating, laying, and refilling extra.

Joints. — One part Portland cement and one part sand, and all inside joints pointed. See Table 16.

Cast-Iron Pipe Culverts. (Fig. 19.) — Cast-iron pipe must have at least 10 feet of embankment and preferably not over 25 feet, carefully tamped.

TABLE 18. — APPROXIMATE WEIGHT OF LEAD AND YARN PER JOINT.

Diam.	3 In.	4 In.	6 in.	8 in.	10 in.	12 in.	14 in.	16 in.	20 in.	24 in.
Lbs. Lead..	7.25	8.75	11.75	15	18	21.5	33	37.25	41.5	53.5
Yarn.	0.11	0.12	0.19	0.25	0.30	0.35	0.40	.45	0.6	0.68

TABLE 18a. — CAST IRON PIPE, APPROXIMATE COST, ETC.
Bell and Spigot Joint.

Size inner diam. pipe.	Length of pipe		Weight in lbs. per		Thickness of pipe.	Cost per ft. at \$35 per ton.	Rip-rap for end walls when reqd. (Fig. 19).
	Over all.	Laid.	Ft. laid.	Length.			
In.	Ft. In.	Ft.			In.		Cu. Yds.
4	12 4	12	22	264	$\frac{7}{16}$	\$0.39
6	12 4	12	36	432	$\frac{1}{2}$.63
8	12 4	12	53	636	$\frac{9}{16}$.93
10	12 4	12	73	876	$\frac{5}{8}$	1.28
12	12 4	12	95	1140	$\frac{11}{16}$	1.66	8
14	12 5	12	119	1428	$\frac{3}{4}$	2.09	8½
16	12 5	12	147	1764	$\frac{13}{16}$	2.57	9
18	12 5	12	176	2112	$\frac{27}{32}$	3.08	10
20	12 5	12	208	2496	$\frac{29}{32}$	3.64	11
24	12 5	12	282	3384	1	4.93	12

Excavating, laying, and filling extra.

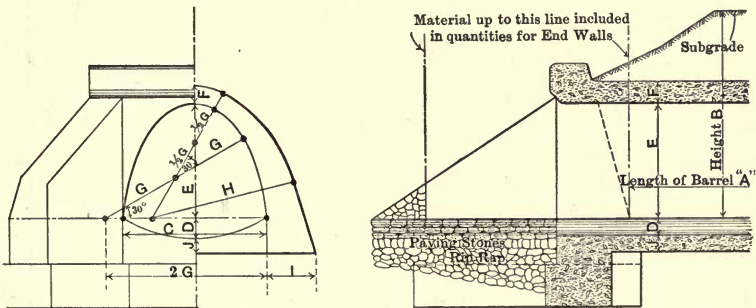

Fig. 20. Concrete Arch Culvert.

Concrete Arch Culverts. (Fig. 20.) — Mixture: One cement, 3 sand and 5 broken stone. Excavating, laying, and refilling extra. See Table 19.

Settlement. — In places where settlement is likely to occur build in 8 or 10-foot lengths, separated with a heavy layer of tarred felt. Joints to be vertical and the width of base increased.

No filling to be done before concrete has thoroughly set, the minimum time allowed being two weeks.

Concrete Arch Culverts.

TABLE 19. — APPROXIMATE COST AND QUANTITIES.

Dimensions.				Span.		Height.		Length of barrel.		Concrete (cu. yds.).				Paving stones.		Riprap.		Approx. total cost of culvert.
J.	I.	H.	G.	F.	E.	D.	C.	B.	A.	Per lin. ft.	2 ends.	In culvert complete.	Cost at \$10.	Sq. yds.	At \$1.50.	Cu. yds.	At \$3.	Dols.
6	1 6	4 2 $\frac{1}{2}$	3 $\frac{1}{16}$	8	3 2 $\frac{1}{8}$	6	4	15	50	.5	18	43	430	9	13.50	4	12	456
								20	64	.5	18	50	500	9	13.50	4	12	526
								30	94	.5	18	65	650	9	13.50	4	12	676
								40	124	.5	18	80	800	9	13.50	4	12	826
								50	154	.5	18	95	950	9	13.50	4	12	976
8	1 9 $\frac{1}{2}$	5 2 $\frac{3}{8}$	2 10	9	4 0 $\frac{1}{2}$	8	5	15	46	.8	27	64	640	14	21.	6	18	680
								20	61	.8	27	76	760	14	21.	6	18	800
								30	91	.8	27	100	1000	14	21.	6	18	1040
								40	121	.8	27	124	1240	14	21.	6	18	1280
								50	151	.8	27	148	1480	14	21.	6	18	1520
8	2 0	6 2 $\frac{1}{4}$	3 4 $\frac{1}{2}$	10	4 10 $\frac{3}{8}$	9 $\frac{1}{8}$	6	15	43	1.0	40	83	830	20	30.	8	24	884
								20	58	1.0	40	98	980	20	30.	8	24	1034
								30	88	1.0	40	128	1280	20	30.	8	24	1334
								40	118	1.0	40	158	1580	20	30.	8	24	1634
								50	148	1.0	40	188	1880	20	30.	8	24	1934
8	2 2	7 1 $\frac{1}{8}$	3 11 $\frac{1}{2}$	11	5 7 $\frac{3}{8}$	11 $\frac{1}{2}$	7	15	40	1.25	54	104	1040	26	39.	10	30	1110
								20	55	1.25	54	123	1230	26	39.	10	30	1300
								30	85	1.25	54	161	1610	26	39.	10	30	1680
								40	115	1.25	54	199	1990	26	39.	10	30	2060
								50	145	1.25	54	237	2370	26	39.	10	30	2440

Concrete Arch Culverts (Continued).

TABLE 19. — APPROXIMATE COST AND QUANTITIES.

Dimensions.				Span.		Height.		Length of barrel.		Concrete (cu. yds.).				Paving stones.		Riwrap.		Approx. total cost of culvert.								
J.	I.		H.		G.		F.		E.		D.		C.		B.		A.		Per lin. ft.	2 ends.	In cul-vert com-plete.	Cost at \$10.	Sq. yds.	At \$1.50.	Cu. yds.	At \$3.
	In.	Ft.	In.	Ft.	In.	Ft.	In.	Ft.	In.	Ft.	In.	Ft.	In.	Ft.	In.	Ft.	In.	Ft.								
8	2	6	8	1 $\frac{1}{16}$	4	6 $\frac{1}{2}$	12	6	5 $\frac{3}{4}$	12 $\frac{3}{4}$	8	20	52	1460	68	146	35	52.50	14	42	1537					
												30	82	1910	68	191	35	52.50	14	42	1987					
												40	112	2360	68	236	35	52.50	14	42	2437					
												50	142	2810	68	281	35	52.50	14	42	2887					
												60	172	3260	68	326	35	52.50	14	42	3337					
8	3	2	10	0 $\frac{1}{16}$	5	7 $\frac{7}{8}$	13	8	1 $\frac{1}{4}$	1	4 $\frac{1}{16}$	20	46	2090	107	209	55	82.50	22	66	2240					
												30	76	2750	107	275	55	82.50	22	66	2900					
												40	106	3410	107	341	55	82.50	22	66	3560					
												50	136	4070	107	407	55	82.50	22	66	4220					
												60	166	4730	107	473	55	82.50	22	66	4880					
9	3	6	11	10 $\frac{1}{2}$	6	9 $\frac{7}{16}$	14	9	8 $\frac{1}{16}$	1	7 $\frac{5}{16}$	20	40	2850	165	285	76	114.	31	93	3057					
												30	70	3750	165	375	76	114.	31	93	3957					
												40	100	4650	165	465	76	114.	31	93	4857					
												50	130	5550	165	555	76	114.	31	93	5757					
												60	160	6450	165	645	76	114.	31	93	6657					
												25	49	4010	205	401	106	159.	42	126	4295					
												30	64	4610	205	461	106	159.	42	126	4895					
												40	94	5810	205	581	106	159.	42	126	6095					
												50	124	7010	205	701	106	159.	42	126	7295					
												60	154	8210	205	821	106	157.	42	126	8495					

Rail Concrete Culverts.

For permanent structures where there is insufficient head-room for culvert pipes or concrete arch culverts, rail concrete culverts are used.

The spans given are from 4 to 10 feet, the arrangement consisting of concrete retaining walls, sloped with the bank, with concrete reinforced floor over, 10 to 12 inches thick, the reinforcement being old rails embedded in the concrete at about 12-inch centers. The floor is paved with field stones, and the ends of walls riprapped when necessary.

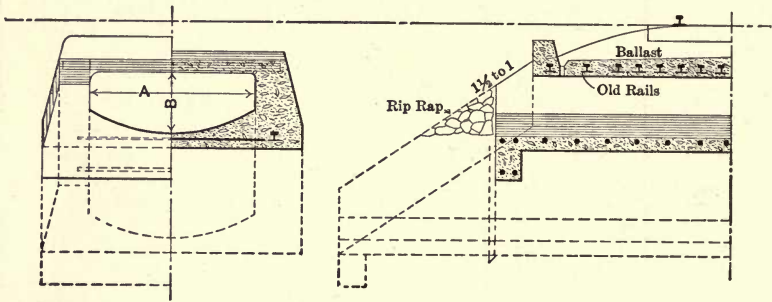

Fig. 21. Rail Concrete Culvert.

TABLE 20. — APPROXIMATE COST, ETC., SINGLE TRACK.

Mixture : 1 cement, 3 sand, and 5 broken stone.

Concrete.						Rails.		Paving.		Riprap.			
A. Span.	B. Depth.		C. Length.		Cu. yds. concrete.	Cost at \$10 per yd.	Tons rails.	Cost at \$22 per ton.	Sq. yds.	Cost at \$1.50 per yd.	Cu. yds.	Cost at \$3 per yd.	Total cost.
	Ft.	In.	Ft.	In.									
4	9	6	21	0	39	\$390	1.10	\$24	10	\$15.00	8	\$24	\$453.00
6	9	6	21	0	42	420	1.40	31	15	22.50	16	48	521.50
8	10	6	24	0	53	530	1.70	38	25	37.50	24	72	675.50
10	11	6	26	0	64	640	2.00	44	35	52.50	48	144	880.50

Excavating and refilling extra.

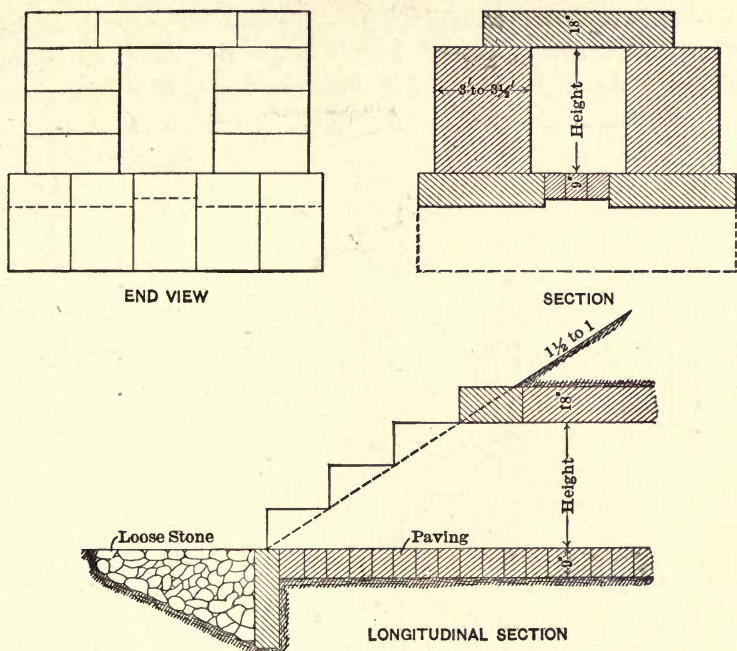

Fig. 22. Stone Box Culverts.

TABLE 21. — APPROXIMATE COST, ETC.

Material : Rubble Masonry, in Cement Mortar.

Size.	Body.		Paving.		Total cost per lin. ft.	Add for 2 end wing walls.				
	Cu. yds. per lin. ft.	Cost at \$8 per cu. yd.	Sq. yds. per lin. ft.	Cost at \$1.50.		Cu. yds.	Cost at \$8.	Rip-rap, cu. yds.	Cost at \$2 per yd.	Total cost for 2 end walls, etc.
Ft. 3×3	1.10	\$8.80	.30	Cts. 45	\$9.25	7	\$56.00	8.00	\$24.00	\$88.00
3×4	1.50	12.00	.30	45	12.45	12	96.00	9.00	27.50	123.00
4×4	1.75	14.00	.40	60	14.60	12	96.00	10.00	30.00	126.00
4×5	2.0	16.00	.50	75	16.75	19	152.00	12.00	36.00	188.00
5×5	2.25	18.00	.50	75	18.75	19	152.00	12.00	36.00	188.00
5×6	2.5	20.00	.60	90	20.90	27	216.00	14.00	42.00	258.00

Excavating and refilling extra.

Cedar Box Culverts. (Fig. 23.) — To be used only when pipe or concrete culverts cannot be placed economically. In sand embankments use side frames as shown in dotted lines.

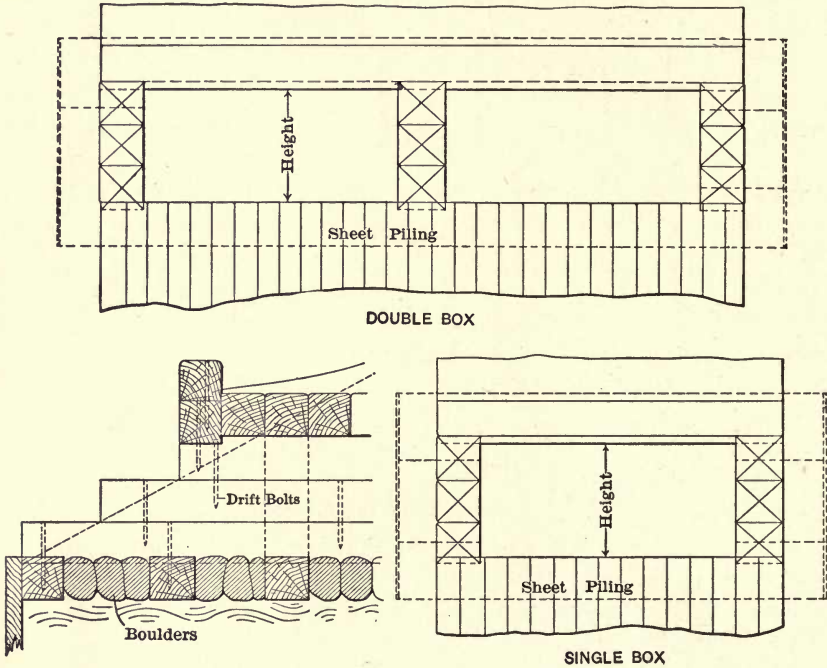

Fig. 23. Wood Box Culverts.

TABLE 22. — APPROXIMATE COST, ETC.

Size.	Kind.	Ft. B.M. per ft.	Cost at \$30 per M.	Paving, sq. yds. per ft.	Cost at \$2 per sq. yd.	Iron, lbs. per ft.	Cost at 5 cts. per lb.	Approx. cost per ft. complete.
Ft. 2×4	Single	90	\$2.70	0.5	\$1.00	6	Cts. 30	\$4.00
2×4	Double	150	4.50	1.0	2.00	10	50	7.00
4×4	Single	175	5.25	0.5	1.00	15	75	7.00
4×4	Double	275	8.25	1.0	2.00	20	180	11.25

Sheet pile at ends when scouring is likely to occur.

Excavating and refilling extra.

CHAPTER IV.

**BRIDGES, TRESTLES, RETAINING WALLS, CRIBS,
TUNNELS.****Bridges.**

Deck Plate Girders. (Fig. 24.) — Deck plate bridges are made of steel plates and angles, fabricated and riveted up into girders, etc., in the shops.

The girders are placed at 9 feet centers more or less, and are held laterally by steel brace frames at varying intervals placed cross-wise, and by longitudinal bracing top and bottom.

Usually the span is completely shop-riveted and shipped ready to drop into place, so that it is only necessary to insert the stone bolts and erect the floor, which is very easily done.

The ends of girders resting on the masonry are supported on steel bearing and bed plates bolted to the bridge seats; the bolt holes are slotted to allow for expansion and contraction for bridges up to 50 feet span, and for bridges over this limit, bearing and pin-centered bed plates with steel rollers are generally used.

Generally speaking, though not the cheapest type of bridge to use, it is the most convenient when ample clearance can be had.

Approximate weight and cost of Deck Plate Girder Spans from 20 to 100 feet are given in table No. 23.

Half Deck Plate Girders. (Fig. 25.) — Half deck plate bridges are fabricated in the same manner, but the girders, frame and bracings are shipped loose and field riveted to the girders when placed. The girders are widened out to allow train clearance between, as the floor is placed below the top flanges of the bridge; the brace frames being somewhat shallow are reinforced by gusset plates, which extend from the top to the bottom flanges in triangular form.

The floor system, on account of the longer distance between girders, is very much heavier than the deck floor; in many cases it is built of steel and reinforced concrete, with ties embedded in ballast.

This type of bridge is convenient, and used to a large extent where the bridge clearance is limited. The wood floor between girders is the cheapest, but steel floor beams and stringers is better construction.

Approximate weight and cost of Half Deck Plate Girder Spans from 20 to 90 feet, are given in table No. 24 (wood floor between girders).

Deck and Through Trusses. (Figs. 26 and 27.)—Deck and through lattice truss bridges are fabricated from plates, angles, etc., and shop riveted in sections for different members; the trusses are usually shop riveted and shipped in one or two lengths, the frames, bracing, etc., being field riveted to them during erection at the site.

The deck bridges have cross brace frames at every panel and longitudinal bracing top and bottom; the floor is placed on top of the main girders or independent floor beams, and stringers are inserted on which the floor rests.

The through bridges have floorbeams every panel crosswise, with stringers running lengthwise, riveted to the floorbeams. The trusses are cross braced top and bottom in panels, with heavy portal bracing at the inclined arms of each end. The floor is secured to the steel stringers and carries the rails and guards.

Deck truss bridges are used when there is ample clearance, and for high crossings, where it would not be economical to place smaller spans.

Through bridges are used when the clearance is limited, and at wide crossings, where it would not be economical to place shorter spans.

Approximate cost and weight of Deck and Through Truss Bridges are given in tables Nos. 25 and 26.

Drawbridges. (Fig. 28.)—Drawbridges are fabricated and built in a similar manner to the through and deck truss bridges already described. In all cases it is necessary to provide operating mechanism to open and close, lift or lower the same.

They are used for crossing navigable water or canals.

Approximate cost and weight of a few drawbridges are given in table No. 27.

Live Load. — The steel bridges and trestles, for which weights and quantities are given, are assumed to carry, in addition to the dead load, two consolidated engines coupled as shown in diagram below, followed by a train load of 4000 pounds per lineal foot. Floor consists of wood ties, spaced and proportioned to carry the maximum wheel load, distributed over 3 ties, the outer fiber stress on the timber not to exceed 1000 pounds per square inch (without impact).

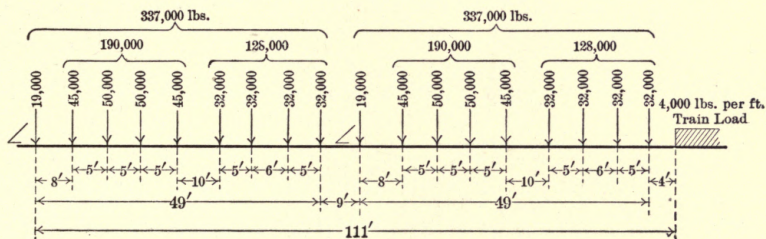

Dead Load. — For calculating stresses the timber weight is assumed at $4\frac{1}{2}$ pounds per foot B. M., and the weight of rails, spikes, and joints at 100 pounds per lineal foot of track.

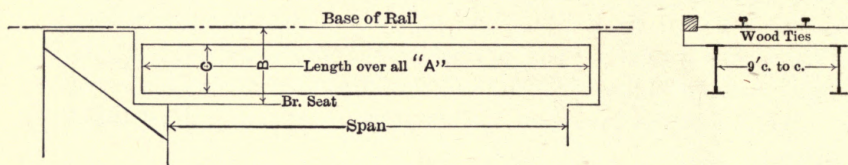

Fig. 24. Deck Plate Girders, 9' 0" centers.

TABLE 23. — APPROXIMATE WEIGHT AND COST OF STEEL DECK PLATE BRIDGES (SINGLE TRACK).

Length over all, ft.	Base of rail to bridge seat, ft. and in.	Depth back to back of angles, ft. and in.	Total weight.	Weight of steel per ft. of bridge.	Cost of steel at 5 cts. per lb.	Bridge ties at 12-in. centers.	Aver. length of floor system.	Cost of floor at \$5 per ft.	Total cost of steel and floor system	Notes.
A.	B.	C.	Lbs.	Lbs.	Dols.	In.	Ft.	Dols.	Dols.	
20	3 9	2 6	12,000	600	600	8×14	30	150	750
30	4 6	3 0	19,500	650	975	8×14	40	200	1175
40	5 6	4 0	28,000	700	1400	8×14	50	250	1650
50	6 6	5 0	40,000	800	2000	8×14	60	300	2300
60	8 0	6 0	57,000	950	2850	8×14	70	350	3200
70	9 0	7 0	73,500	1050	3675	8×14	80	400	4075
80	10 0	8 0	92,000	1150	4600	8×14	90	450	5050
90	11 6	9 0	121,500	1350	6075	8×14	100	500	6575
100	13 0	10 0	150,000	1500	7500	8×14	110	550	8050

For quantities in abutments and piers, see pages 62, 63, and 64.

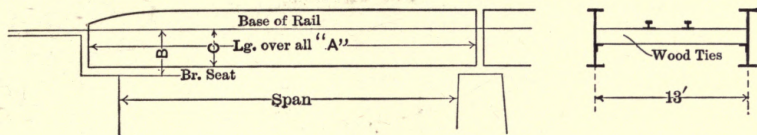

Fig. 25. Half Deck Plate Girders, 13 ft. centers.

TABLE 24. — APPROXIMATE WEIGHT AND COST OF STEEL HALF DECK PLATE BRIDGES (SINGLE TRACK).

Length over all, ft.	Base of rail to bridge seat, ft. and in.	Depth back to back of angles, ft. and in.	Total weight.	Weight of steel per ft. of bridge.	Cost of steel at 5 cts. per lb.	Bridge ties at 12 in. centers.	Aver. length of floor system.	Cost of floor system at \$5 per ft.	Total cost of steel and floor system.	Notes.
A.	B.	C.	Lbs.	Lbs.	Dols.	In.	Ft.	Dols.	Dols.	
20	1 7	13,000	650	650	8×16	30	150	800
30	1 7	21,000	700	1050	8×16	40	200	1250
40	1 7	4	30,000	750	1500	8×16	50	250	1750
50	2 6	5	42,500	850	2125	8×16	60	300	2425
60	4 0	6	60,000	1000	3000	8×16	70	350	3350
70	4 9	7	80,500	1150	4025	8×16	80	400	4425
80	5 9	8	100,000	1250	5000	8×16	90	450	5450

For quantities in abutments and piers, see pages 62, 63, and 64.

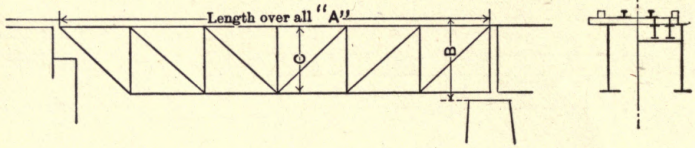

Fig. 26. Deck Lattice Rivetted Trusses.

TABLE 25. — APPROXIMATE WEIGHT AND COST OF STEEL DECK LATTICE RIVETED TRUSS BRIDGES (SINGLE TRACK).

Width center to center of girders.	Length over all.		Base of rail to bridge seat.		Depth center to center of chords.		Total weight.	Weight of steel per ft. of bridge.	Cost of steel at 5 cts. per lb.	Bridge ties at 12-in. centers.	Average length of floor system.	Cost of floor system at \$5 per ft.	Total cost of steel and floor system.	Notes.
	A.	B.	Ft.	In.	Ft.	In.								
9	100	13 0	10	6	150,000	1500	7,500	8×14	110	550	8,050		
9	125	16 0	13	0	225,000	1800	11,250	8×14	135	675	11,925		
16	150	27 3	25	6	315,000	2100	15,750	8×10	160	800	16,550		
18	175	28 6	28	0	420,000	2400	21,000	8×10	185	925	21,925		
20	200	30 6	30	0	540,000	2700	27,000	8×10	210	1050	28,050		

For quantities in abutments and piers, see pages 62, 63, and 64.

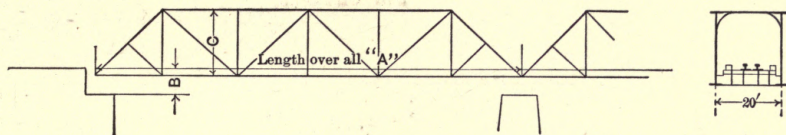

Fig. 27. Through Lattice Rivetted Trusses.

TABLE 26.—APPROXIMATE WEIGHT AND COST OF STEEL THROUGH RIVETED TRUSS BRIDGES (SINGLE TRACK).

Length over all. A.	Base of rail to bridge seat. B.	Depth c. to c. of chords.	Total weight.	Weight of steel per ft. of bridge.	Cost of steel at 5 cts. per lb.	Bridge ties at 12-in. centers.	Average length of floor system.	Cost of floor system at \$5 per ft.	Total cost of steel and floor system.	Notes.
Ft.	Ft. In.	Ft. In.	Lbs.	Lbs.	Dols.	In.	Ft.	Dols.	Dols.	
100	6 0	22 6	180,000	1800	9,000	8×10	110	550	9,550
125	6 6	25 0	262,500	2100	13,125	8×10	135	675	13,800
150	7 0	27 6	360,000	2400	18,000	8×10	160	800	18,800
175	7 6	30 0	472,700	2700	23,635	8×10	185	925	24,560
200	8 0	32 6	600,000	3000	30,000	8×10	210	1050	31,050

For quantities in abutments and piers, see pages 62, 63, and 64.

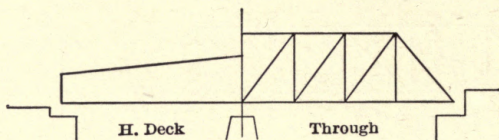

Fig. 28. Half Deck and Through Drawbridges.

TABLE 27.—APPROXIMATE WEIGHT AND COST OF STEEL DRAWBRIDGES
(SINGLE TRACK).

A Length over all.	Kind of bridge.	Width center to center of chords.		Total weight.	Weight of steel per ft. of bridge.	Cost of steel at 5 cts. per lb.	Bridge ties at 12" centers.	Average length of floor system.	Cost of floor system at \$6 per ft.	Total cost of steel and floor system.	Notes.
		Ft.	In.	Lbs.	Lbs.	Dols.	Inches.	Ft.	Dols.	Dols.	
Ft. 70	H. deck pl.	12	7	75,000	1070	3,750	8×15	70	420	4,170
130	Deck pl.	9	0	216,000	1670	10,800	8×16	130	780	11,580
250	Thro' latt.	18	6	750,000	3000	37,500	8×10	250	1500	39,000

Bridge Abutments.

Abutments may be built either of stone or concrete. For the latter, if current is strong, the up-stream corners should be stone-faced. Leave 4-inch clearance between face of ballast wall and end of girders. Frost batter of walls to be finished smooth.

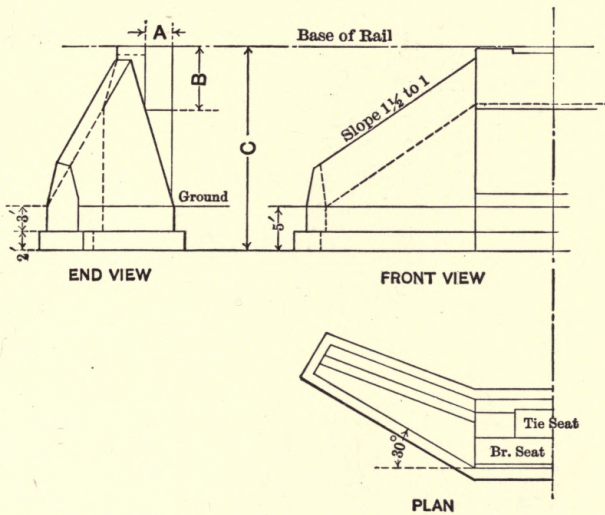

Fig. 29. Bridge Abutments.

Bridge seats to be finished to a dead level throughout on tangents, and on curves given a slope parallel to the super-elevation of the outer rail, including tie seat on the ballast wall.

On curves locate abutments normal to chord of span.

TABLE 28.—ABUTMENTS FOR DECK PLATE GIRDERS. (Fig. 29.)

Span.	Bridge seats.		Approximate cubic yards in one abutment. Height "C."												
	A.	B.	10	14	18	22	26	30	34	38	42	46	50		
	Ft.	In.	Ft.	Ft.	Ft.	Ft.	Ft.	Ft.	Ft.	Ft.	Ft.	Ft.	Ft.		
20	2	0	3	9	28	64	114	180	265	370	498	650	829	1036	1274
30	2	3	4	6	29	66	116	182	267	372	500	652	831	1038	1276
40	2	6	5	6	30	68	118	184	269	374	502	654	833	1040	1278
50	2	9	6	6	31	70	120	186	271	376	504	656	835	1042	1280
60	3	0	8	0	72	124	190	275	380	508	660	839	1046	1284
70	3	3	9	0	74	128	195	279	384	512	664	843	1050	1289
80	3	6	10	0	75	130	198	283	388	516	668	847	1054	1293
90	4	0	10	6	76	133	203	288	393	520	673	852	1059	1297

TABLE 29.—ABUTMENTS FOR HALF DECK GIRDERS. (Fig. 29.)

Span.	Bridge seats.		Approximate cubic yards in one abutment. Height "C."												
	A.	B.	10	14	18	22	26	30	34	38	42	46	50		
	Ft.	In.	Ft.	Ft.	Ft.	Ft.	Ft.	Ft.	Ft.	Ft.	Ft.	Ft.	Ft.		
20	2	0	1	8	27	63	113	179	264	369	497	649	828	1035	1273
30	2	3	1	8	28	65	115	181	266	371	499	651	829	1037	1275
40	2	6	1	8	29	66	116	182	267	372	500	652	830	1038	1276
50	2	9	2	5	29	67	117	183	268	373	501	654	832	1040	1278
60	3	0	3	11	30	70	121	187	272	377	505	658	835	1043	1281
70	3	3	4	10	31	72	124	191	276	381	509	663	840	1048	1286
80	3	6	5	9	32	74	127	195	280	384	512	666	843	1051	1289

TABLE 30.—ABUTMENTS FOR THROUGH BRIDGES. (Fig. 29.)

Span.	Bridge seats.		Approximate cubic yards in one abutment. Height "C."												
	A.	B.	10	14	18	22	26	30	34	38	42	46	50		
	Ft.	In.	Ft.	Ft.	Ft.	Ft.	Ft.	Ft.	Ft.	Ft.	Ft.	Ft.	Ft.		
100	4	0	5	6	38	84	139	208	294	398	526	680	857	965	1303
125	4	0	5	9	39	85	140	210	296	400	528	682	859	967	1305
150	4	0	5	9	39	85	141	211	298	402	530	684	861	969	1307
200	4	6	6	0	40	86	143	213	301	405	533	687	865	973	1311

Bridge Piers.

Piers may be built either of concrete or stone. If of concrete, the up-stream cutwater exposed to the action of swift currents, ice, or driftwood should have stone facing, to about 3 feet above high water.

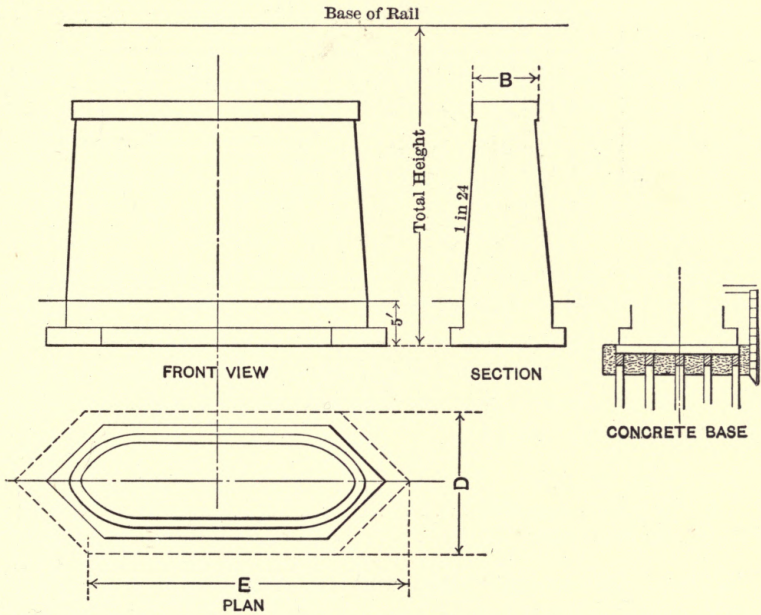

Fig. 29a. Bridge Piers.

TABLE 31. — APPROXIMATE CUBIC YARDS IN ONE PIER. (Fig. 29a.)

Width of piers.		For girders 13-foot centers or less. Total height.												
		10 Ft.	14 Ft.	18 Ft.	22 Ft.	26 Ft.	30 Ft.	34 Ft.	38 Ft.	42 Ft.	46 Ft.	50 Ft.	54 Ft.	58 Ft.
" B."														
4	0	39	56	74	93	114	137	161	186	214	243	274	306	340
4	6	45	64	84	105	129	155	180	208	238	269	304	338	376
5	0	50	71	93	118	143	171	200	231	263	298	334	371	412
5	6	56	79	104	131	159	189	220	254	289	326	365	406	449
6	0	62	88	115	144	175	207	242	278	317	358	399	443	489
6	6	68	96	126	158	191	227	264	303	344	387	433	480	529
7	0	75	106	138	172	209	247	287	329	373	420	467	518	570
7	6	81	115	150	187	226	267	310	355	403	454	504	558	614
8	0	88	124	165	203	245	289	335	383	434	486	541	598	657

TABLE 32.—APPROXIMATE CUBIC YARDS IN ONE PIER. (Fig. 29a.)

Width of piers. " B "	For girders over 13-foot centers up to 20-foot centers. Total height.												
	10 Ft.	14 Ft.	18 Ft.	22 Ft.	26 Ft.	30 Ft.	34 Ft.	38 Ft.	42 Ft.	46 Ft.	50 Ft.	54 Ft.	58 Ft.
Ft. In.													
6 0	83	117	152	190	231	273	318	364	415	467	520	576	635
6 6	90	127	166	208	251	297	345	395	448	503	561	621	683
7 0	98	139	181	225	272	321	373	427	483	543	603	667	733
7 6	106	150	195	243	293	346	401	458	519	583	647	715	786
8 0	114	161	211	262	316	372	431	492	557	622	692	764	837
8 6	123	174	227	281	339	399	461	528	595	664	738	812	891
9 0	132	186	241	301	362	426	492	562	632	707	783	861	941

When it is necessary to carry abutments or piers on piles, a grillage of 12"×12" timbers embedded in concrete is very commonly used to form a base over the piles as shown in Fig. 29a.

The piles and timbers are placed about 3-foot centers, and the quantities per square foot of area covered (D. × E.) would be approximately as follows:

Number of piles.....	0.12 × D. E.
Cubic yards concrete.....	0.06 × D. E.
Ft. B. M. timber.....	8.0 × D. E.

Estimate for concrete base and pile foundation from above data:

Piles 20 feet long, D. 9 feet and E. 18 feet = 162 square feet.

No. of piles $162 \times .12 = 19 \times 20 = 380$ ft. at 25 cts.....	\$95.00
Ft. B. M. 12×12 timbers $162 \times 8 = 1296$ ft. B. M. at \$30..	38.88
Cu. yds. concrete, $162 \times .06 = 9.7$ cu. yds. at \$8.....	77.60

Total..... \$201.48

In addition to the concrete base it is usually necessary to place caissons or wood cribs around the piers, forming a water-tight box from which the water is pumped so that the foundations can be laid dry. These boxes are made up of 12"×12" timbers framed and braced, or sheet piling, either wood or steel, is often used. The cost and quantities vary with the nature of foundation and are usually paid for at unit prices.

In place of the concrete and timber base sometimes a solid floor 24 inches thick made up of 12"×12" timbers drift-bolted together is used as a floating platform on which the masonry is built, and sunk into position over the piles, the piles having previously been cut off by an under-water saw.

The objection to this method is the liability in case of an ice shove for the pier to slide between the platform and piles.

All piers and abutments should be sufficiently protected from scour, which is one of the chief sources of bridge failures. This can only be done by taking foundations down to solid bottom and anchoring the masonry to the foundation bed by large stone bolts, or dowels.

In running water they should be further protected by stone riprapping all around; and when the clearance is limited and severe ice shoves are likely to occur, crib protection piers filled with stones, placed 25 to 50 feet ahead of each pier up stream, should be used.

Timber Trestles.

Timber trestles are of two types, pile and frame, and are used principally for rapid or cheap first-cost construction, to be eventually filled or replaced by permanent structures at some future date.

The structure must be made rigid by sway bracing the bents crosswise and longitudinally, to withstand the pull from a moving train, or the thrust when brakes are applied. Trestle failures are frequently caused by insufficient bracing. Trestles of long lengths should have fire breaks; that is, a few bents at varying intervals should be filled in or made fireproof, so that should a fire occur, the whole trestle will not be destroyed.

Frame Trestles. (Fig. 30a.) — The bents are made of square timber framed together and braced, the economic limit of height being probably 100 feet. The foundation may be piles cut off at ground level, with timber sills on top or masonry piers. The structures must be made rigid by bracing transversely and longitudinally throughout.

Approximate cost and quantities are given in table No. 35.

Pile Trestles. (Fig. 30.) — The bents are formed of several piles with caps and sway bracing, the floor consisting of longitudinal stringers with cross ties, or solid plank with ballast floor on top.

Owing to the long length of piles required, they rarely exceed 30 feet in height.

For heights over 10 feet up to 20 feet, longitudinal bracing should be inserted at least every fifth panel; over 25 feet every alternative panel should be braced, arranged so as to hold the posts midway to stiffen them as columns.

Approximate cost and quantities are given in tables No. 33 and 34.

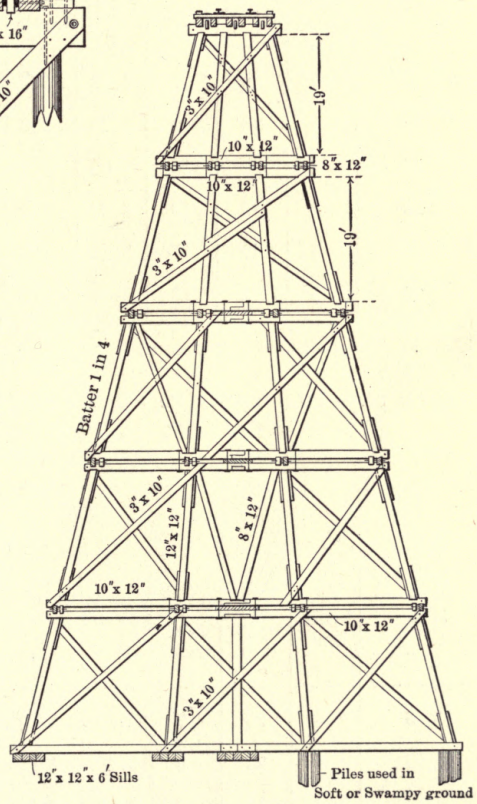
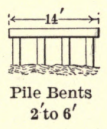
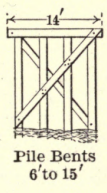
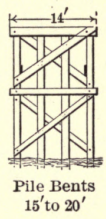
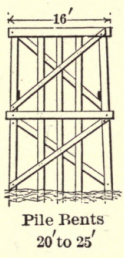
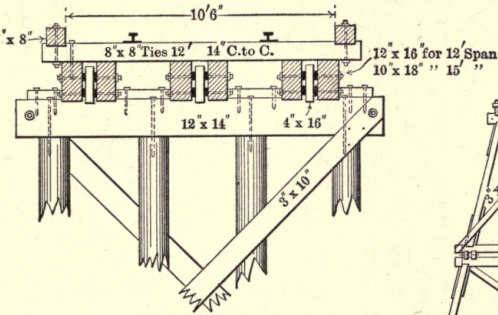

Fig. 30. Pile Trestle.

Fig. 30a. Frame Trestle.

TABLE 33. — PILE TRESTLE: SINGLE TRACK. (Fig. 30.) APPROXIMATE QUANTITIES AND COST COMPLETE.

Bents 12-foot centers.

Height. Bottom of sill to top of cap.	Piles.				Bracing and floor system.				
	No. per bent.	Aver- age length each.	Lineal ft. per ft. of trestle.	Cost at 30 cts. per ft.	Ft. B. M. per ft. of trestle	Cost at \$35 per M. ft. B.M.	Iron per lin. ft. of trestle, lbs.	Cost at 6 cts. per lb.	Approxi- mate total cost per lineal ft. of trestle.
5	4	20	7	\$2.10	220	\$7.70	20	\$1.20	\$11.00
10	4	25	9	2.70	230	8.05	22	1.32	12.00
15	4	30	10	3.00	240	8.40	24	1.44	12.84
20	4	35	12	3.60	250	8.75	26	1.56	13.91
25	5	40	17	5.10	260	9.10	28	1.60	15.88
30	5	45	19	5.70	270	9.45	30	1.80	16.95

Rails and fastenings not included. For cost, see p. 13.

TABLE 34. — PILE TRESTLE: SINGLE TRACK. (Fig. 30.) APPROXIMATE QUANTITIES AND COST COMPLETE.

Bents 15-foot centers.

Height. Bottom of sill to top of cap.	Piles.				Bracing and floor system.				
	No. per bent.	Aver- age length each.	Lineal ft. per ft. of trestle.	Cost at 30 cts. per ft.	Ft. B. M. per ft. of trestle.	Cost at \$35 per M. ft. B. M.	Iron per lineal ft. of trestle, lbs.	Cost at 6 cents per lb.	Approxi- mate total cost per lineal ft. of trestle.
5	4	20	7	\$2.10	200	\$7.00	18	\$0.90	\$10.00
10	4	25	9	2.70	210	7.35	20	1.00	11.05
15	4	30	10	3.00	220	7.70	22	1.10	11.80
20	4	35	12	3.60	230	8.05	24	1.20	12.25
25	5	40	17	5.10	240	8.40	26	1.30	14.80
30	5	45	19	5.70	250	8.75	28	1.40	15.85

Rails and fastenings not included. For cost, see p. 13.

TRESTLES.

TABLE 35.—FRAME TRESTLE: SINGLE TRACK. (Fig. 30a.) APPROXIMATE QUANTITIES AND COST.

Bents 15-foot centers.

Bents, bracings, sills, caps, stringers, and floor system.

Height. Base of rail to bot- tom of sill.	Ft. B. M. per lineal ft. of trestle.	Cost at \$35 per M. ft. B. M.	Iron per ft. of trestle, lbs.	Cost at 5 cts. per lb.	Total cost per lineal ft. of trestle.
20	300	\$10.50	20	\$1.00	\$11.50
25	350	12.25	20	1.00	13.50
30	400	14.00	20	1.00	15.00
35	450	15.75	22	1.10	16.85
40	500	17.50	24	1.20	17.70
45	550	19.25	26	1.30	20.55
50	600	21.00	28	1.40	22.40
55	650	22.75	30	1.50	24.25
60	700	24.50	32	1.60	26.10
65	750	26.25	34	1.70	27.95
70	800	28.00	36	1.80	29.80
75	900	31.50	38	1.90	33.40
80	950	33.25	40	2.00	35.25
85	1000	35.00	42	2.10	37.10
90	1050	36.75	44	2.20	38.95
95	1100	38.50	46	2.30	40.80
100	1150	40.25	48	2.40	42.65

Pile foundation extra. Masonry foundation extra.

Rails and fastenings not included. For cost, see p. 13.

Steel Trestles.

For permanent work, in some instances a high steel trestle will be less costly than a fill embankment.

The tower spans are usually made 30 to 40 feet, and the spans between vary from 30 to 80 feet, depending on the height of bents. They are generally made wide enough at the base so as not to require anchorage.

H. E. Vautlet's rule for estimating steel trestles, used by the Canadian Pacific Railroad for preliminary estimates, is as follows:

Steel trestles up to 100 feet in height with 30-foot towers and 60-foot spans. (Fig. 31.)

Number of piles	=	100 + .4 C. D. feet.
Masonry in cubic yards	=	350 + 1.25 C. D. feet.
Weight steel in pounds	=	(C. D. feet × 850) + (S. × 14).
Length of floor	=	A. B. feet.

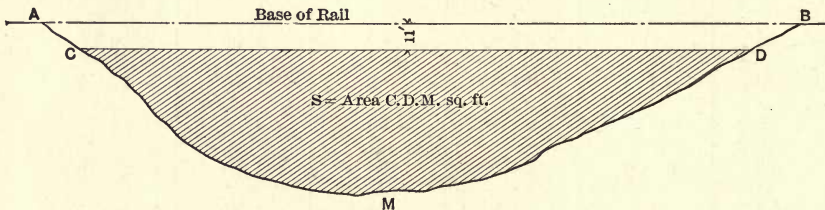

Fig. 31.

Approximate estimate steel trestle on pile foundation from the above (trestle 50 feet high at center, track rails and fastenings not included): A. B. 2400 feet, C. D. 2100 feet, S. 63,000 square feet. Piles 20 feet long.

Piles, $100 + (0.4 \times 2100) = 940 \times 20$ feet long each = 18,800 lineal feet at 20 cts.....	\$3,760.00
Masonry, $300 + (1.25 \times 2100) = 2925$ cubic yards at \$7.....	20,475.00
Steel, $(2100 \times 900) + (63,000 \times 14) = 2,772,000$ lbs. at 4 cts.....	110,880.00
Floor system, 2400 lineal feet at \$5.....	12,000.00
or, about \$62 per lineal foot of trestle.	\$147,115.00

In this instance, unless for other specific reasons, it would evidently be much cheaper to fill, as the cost per cubic yard for filling would have to exceed 80 cents to make the cost equivalent to a steel viaduct.

Howe Truss Bridges.

For branch lines in a timber country and for temporary bridging, Howe truss spans are often used. The chords and braces are made of timber and the vertical rods of steel usually upset, with cast-iron blocks at the angles of braces, which are bolted or doweled into the main members. The best class of timber is used with as few splices as possible.

The loads, quantities, and weights in the table of cost are from Johnson's modern frame structures, taken from the Oregon Pacific (A. A. Schenck, chief engineer) and published in the *Engineering News*, April 26, 1890. The live load assumed was two 88-ton engines followed by a train load of 3000 pounds per foot.

For deck bridges add 20 per cent to the weight of the timber and deduct 20 per cent from the weight of the wrought iron.

To protect the chords from engine sparks, galvanized iron is often used. Sometimes also the timbers are treated by a chemical process to prevent or retard decay, or whitewashed with a fire-resistant compound. They require to be closely inspected at all times.

TABLE 36. — APPROXIMATE COST, WEIGHTS AND QUANTITIES FOR HOWE TRUSS BRIDGES.

Length of span.	Style of truss.	Height of truss.	No. of panels.	Total dead and live load per ft.	Estimated quantities.			Approximate cost erected.
					Timber, ft. B. M.	Wrought iron.	Cast iron.	
Ft.		Ft.				Lbs.	Lbs.	Dols.
30	Pony	9	4	6000	10,200	2,200	1,000	550
40	...do...	11	4	5500	13,400	3,000	1,300	740
50	...do...	11	6	5200	19,100	5,700	2,900	1170
60	...do...	12	6	4900	22,800	6,800	3,700	1410
70	...do...	13	7	4800	30,000	17,500	8,300	2480
80	...do...	14	8	4800	35,400	22,000	10,000	3010
90	...do...	15	9	4800	42,800	28,700	12,600	3890
90	Through	25	8	4800	41,900	33,100	13,300	4020
100	...do...	25	9	4800	48,900	41,600	14,300	4810
110	...do...	25	10	4800	54,800	48,200	16,000	5290
120	...do...	25	11	4800	62,100	56,900	18,300	6350
130	...do...	25	12	4700	70,200	67,300	20,900	7320
140	...do...	25	13	4700	78,200	73,900	23,300	8100
150	...do...	25	14	4700	86,700	87,300	27,100	9330

Prices assumed : Timber, \$35 per M. ft. B. M. erected; steel, 5 cts. per pound erected; cast iron, 4 cts per pound erected.

Supervision and contingencies, 10%.

Subway and Overhead Crossings.

The natural location very often decides whether the crossing will be over or under the tracks. In towns and cities in many cases the railroads are compelled to raise their tracks and provide subways for city traffic to the detriment of railroad traffic.

When team, street car, and foot traffic is very heavy and dense this may be necessary; when car and team traffic, however, is light, and foot traffic considerable, an overhead crossing is generally adopted, as the cost is a great deal less.

Approximate cost. — The approximate cost of overhead crossings for team and foot traffic only (Fig. 32), varies from \$1.25 to \$2.00 per square foot of area covered.

For overhead crossings for teams, street car service, and foot traffic, the cost varies from \$2.00 to \$3.00 per square foot of area covered. (Fig. 33.)

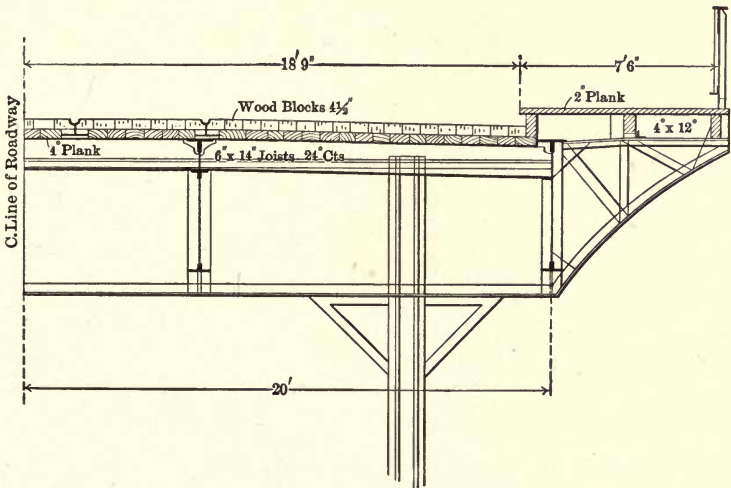

Fig. 33. Cross-Section Overhead Bridge.

For subways, steel girders, and reinforced concrete (Fig. 34), the cost varies from \$5.00 to \$8.00 per square foot of area covered, including approaches.

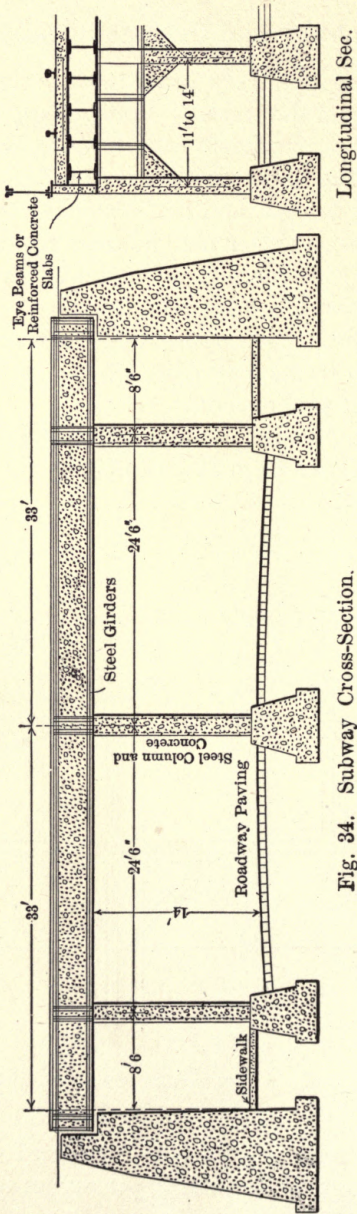

Fig. 34. Subway Cross-Section.

CONSTRUCTION. (Fig. 32.)

Overhead Crossings. — Retaining walls and piers concrete to five feet below finished ground level, portion over tracks between opposite retaining walls, steel viaduct with roadway supported on steel and wood joists, covered with plank and wood block paving, with sidewalk carried on iron brackets.

The space inclosed by the retaining walls is filled in and finished with macadam roadway on top, and the sidewalk continued on one side carried on cedar sills, with a handrail on either side.

Subways. (Fig. 34.) — Abutments and piers reinforced concrete to five feet below finished subway grade, tracks carried overhead by steel girders and frames incased in concrete with reinforced concrete slab floor, carrying the ballast and track.

APPROXIMATE ESTIMATE OF OVERHEAD ROAD CROSSING. (Fig. 32.)

(40 feet wide × 1100 feet long.)

Excavation used for filling —

Concrete walls and piers, 3700 cubic yards at \$7.....	\$25,900.00
Steel erected, 425,000 pounds at 5 cts.....	21,250.00
Railing, 1500 lineal feet at 75 cts.....	1,125.00
Sidewalk, 800 lineal feet at \$2.....	1,600.00
Flooring, 60,000 feet B. M. at \$40.....	2,400.00
Wood block paving, 1500 square yards at \$3.50.....	5,250.00
Macadam on approaches, 1800 cubic yards at 50 cts.....	900.00
Earth fill, 7400 cubic yards at 50 cts.....	3,700.00
	<hr/>
	\$62,025.00
Supervision and contingencies, 10%.....	6,275.00
Total.....	<hr/>
	\$68,300.00

or \$1.55 per square foot of area covered.

Guards.

Bridge and Trestle Guards. — For through and deck bridges, including trestles, it is customary to make provision by guards for the protection of trains in case of derailment, on and approaching the structure to prevent a wreck.

Wood Guards. — The ordinary wood guard consists of an 8" × 10" timber, placed on each side of the structure about 6 feet from center of track, with a 5" × 8" inner guard, placed about 3 feet 6 inches from the center of track on each side; these timbers are dapped down and bolted to the floor system, the inner guard being flared out at each end for about 30 feet, to meet the outer guard after passing off the bridge.

The cost of the wood guard is usually included in the floor system of the structure.

Jordan Guard. — The Jordan guard is made by placing two or three lines of light rails inside the track rails, equally spaced and parallel with them; at each end of the structure the rails nearest the track are sometimes curved to meet at a point in the center of the track, a distance of 20 feet or thereabouts, or the head portions of the rails are flared off at the ends and a metal plate used, fastened to the ties.

The rails are carried over the entire structure, and sometimes for a distance of 50 to 100 feet beyond the ballast walls.

The cost of the Jordan guard, using three old rails, at \$20.00 per ton, is approximately 75 cents to \$1.00 per lineal foot.

RETAINING WALLS.

TABLE 37.

Height of Wall in feet	Area of each course in sq. ft.	Area of each height in sq. ft.					Cubic yards per foot run for each course	Cubic yards per foot run for each height	Height of Wall in feet		
1											1
2			MASONRY RETAINING WALL MINIMUM HEIGHT 8 FEET. DOES NOT INCLUDE COPING NOR FOOTINGS.							2	
3									3		
4									4		
5									5		
6									6		
7									7		
8	6.44	39.59							8		
9	6.73	46.32							9		
10	7.02	53.34							10		
11	7.31	60.64							11		
12	7.60	68.24							12		
13	7.90	76.14							13		
14	8.19	84.33							14		
15	8.48	92.81							15		
16	8.77	101.58							16		
17	9.06	110.64							17		
18	9.35	120.00							18		
19	9.65	129.64							19		
20	9.94	139.58							20		
21	10.23	149.81							21		
22	10.52	160.33							22		
23	10.81	171.14							23		
24	11.10	182.25							24		
25	11.40	193.65							25		
26	11.69	205.34							26		
27	11.98	217.32							27		
28	12.27	229.59							28		
29	12.56	242.15							29		
30	12.85	255.00							30		
31	13.15	268.15							31		
32	13.44	281.59							32		
33	13.73	295.39							33		
34	14.02	309.34							34		
35	14.31	323.65							35		
36	14.60	338.25							36		
37	14.90	353.15							37		
38	15.18	368.33							38		
39	15.48	383.81							39		
40	15.77	399.58							40		

Fig. 35.

Retaining Walls.

Description. — Retaining walls are built to sustain earth, sand or other filling deposited behind it, after it is erected.

Fig. 35 illustrates a retaining wall, which has been used by the C. P. R., in rock-faced masonry construction, and the quantities given are conveniently tabulated for estimating purposes, Table 37.

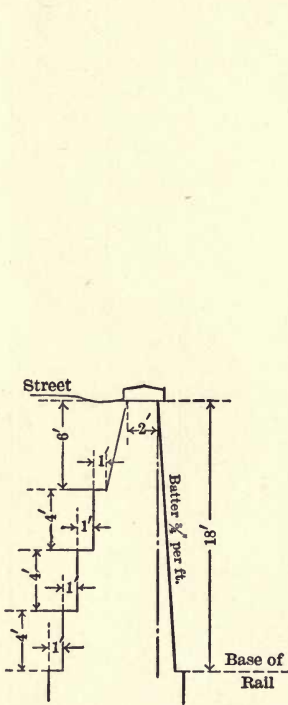

Fig. 36. Retaining Wall,
N. Y. C. & H. R. R.

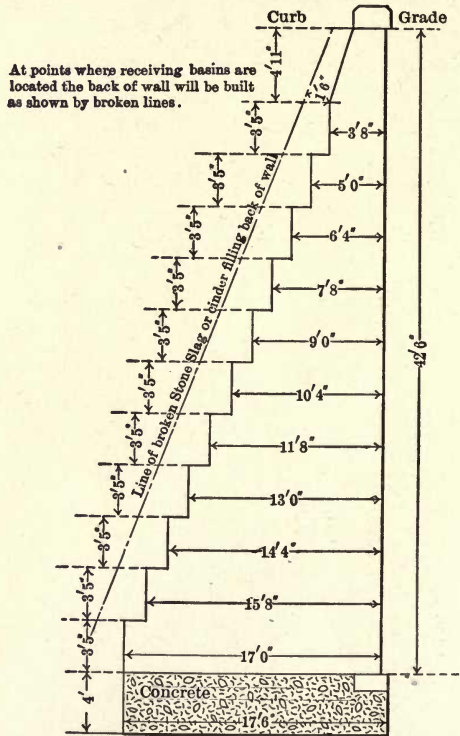

Fig. 37. Retaining Wall, Harlem
River Speedway.

Fig. 36 illustrates the Standard retaining wall section, 18 feet high, New York Central and Hudson River Railroad, built in good soil, with first class quality rock-faced ashlar, set in cement.

Fig. 37 illustrates a retaining wall designed for the Harlem River Speedway, New York, as illustrated in the *Engineering Record*, Oct. 6, 1894.

Construction.—Masonry for bridge and retaining walls is usually rock-faced, with edges pitched true to line and exact batter, and finished with dimension stone coping on top. The courses should not be less than 14 inches, or more than 30 inches thick, diminishing regularly from bottom to top. Mortar beds not over one-half inch thick when laid, face joints squared at least 12 inches deep. The walls must be well bonded throughout with headers at least 4 feet long, occupying one-fifth face of wall, with stretchers not less than 4 feet long, having at least one and one-quarter times as much bed as thickness of course.

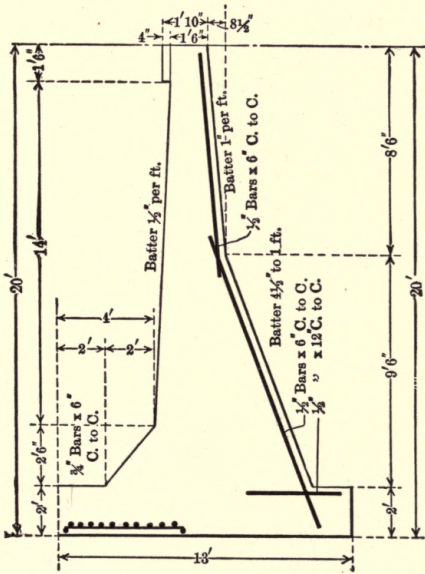

Fig. 38. Retaining Wall, C. B. & Q. Ry.

Where wall is less than 3 feet, the face stone should pass entirely through.

Backing, large stone, roughly bedded and neatly jointed, joints not to exceed 1 inch. At least one-half of the stone to be of the same size as face stone, with parallel ends.

Frost batters to be built without projecting stones, sloped and finished smooth with a coat of neat cement.

Weep holes for drainage to be provided; in place of holes 2-inch iron pipe may be used.

Cost. — The cost of rock-faced ashlar retaining walls varies considerably, depending on the location and proximity to quarries, and ranges from \$8.00 to \$25.00 per cubic yard in place.

Excavation ordinary per cubic yard	25 to 50 cents.
Excavation hard with boulders	50 to 75 cents.
Excavation rock benching	\$2.00 to \$3.50.

Fig. 38 illustrates a cross section of a typical reinforced concrete retaining wall 20 feet high, C. B. & Q. Ry., in connection with the work of elevating its tracks at Chicago.

Cribb.

Crib Work. — For cheap first cost or temporary construction across or alongside water fronts or embankments, or for abutments, piers, dams, retaining walls, wharves, etc., wooden cribs are used extensively. Figs. 39, 40, and 40a.

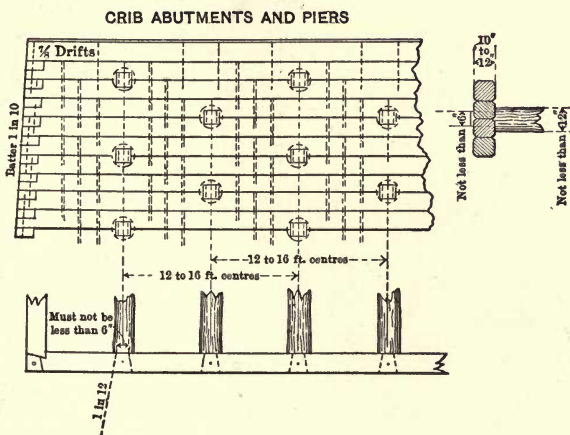

Fig. 39.

The bottoms of the cribs are constructed to suit the irregularities or unevenness of the ground, any deposit or obstruction in the bottom being removed so that a section when sunk in place will take an even bearing throughout; when filled with ballast the top of the crib should be reasonably straight and in good alignment. Sometimes the portion under low water level is built of several cribs, piles being driven on the outer line of the work against which the cribs may be floated and sunk, the guide piles being cut off below low water after the work is completed.

Construction. — The timbers are usually cedar under water and tamarac above with bark removed; the outer timbers are hewn or sawn perfectly true and parallel on two opposite sides to a face of at least 9 inches, and from 10 to 12 inches thick, the joints made as close as possible without dressing and so laid as to break joint; all cross ties are dovetailed; notches are cut in

the face timbers to receive the dovetails, one-half into the course above and one-half into the course below; timbers at the angles are halved and carefully dovetailed. All timbers held by drift bolts $\frac{7}{8}$ inch in diameter, equal to a depth of not less than $3\frac{1}{2}$ courses; sometimes tree nails of oak or rock-elm are used in place of drifts.

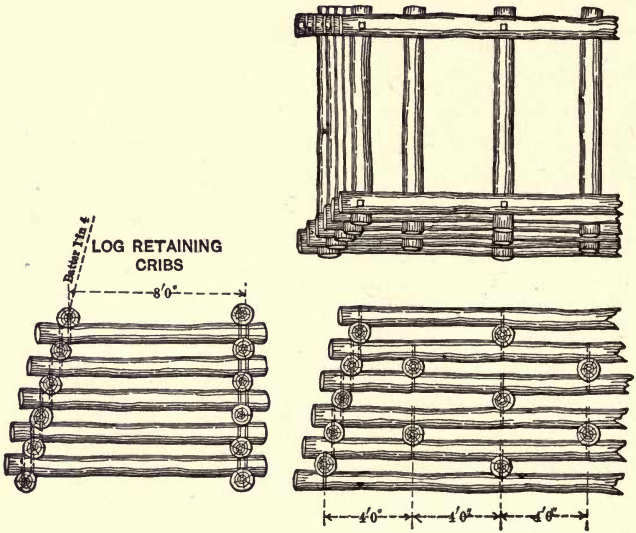

Fig. 40.

The cross and longitudinal ties may be round logs long enough to pass completely through the crib from side to side; when they intersect they are boxed down on each other and bolted.

A close floor of cedar spars, not less than 8 inches in diameter, is laid on the first tier of cross ties to hold the ballast, or stone filling; sometimes the floor is laid solid crosswise of the crib and resting on bottom longitudinal face courses.

APPROXIMATE COST OF CRIBBING IN PLACE.

Squared timbers per thousand feet board measure.....	\$30.00 to \$50.00
Round cedar timbers per foot.....	.12 to .20
Iron in crib per pound.....	.04 to .06
Filling (stone or ballast) per cubic yard.....	.25 to 1.50
Leveling off and clearing (dry) per cubic yard.....	.20 to .30
Leveling off and clearing (wet).....	.50 to 1.00

Crib Abutments. (Fig. 40a.) — For permanent structures on high fill embankments timber crib abutments are sometimes placed, when the cost of masonry to solid ground would be excessive and out of proportion to the balance of the structure. After a number of years, when the bank is solidified, the crib may be removed and a masonry abutment placed in the usual way.

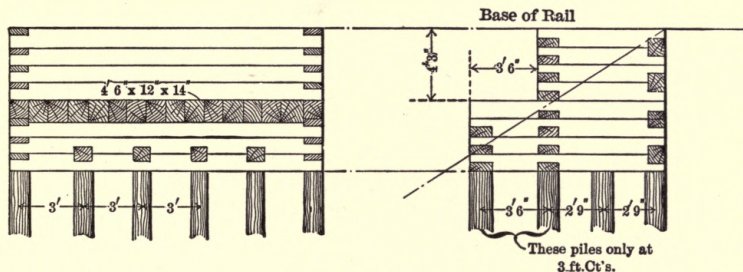

Fig. 40a.

APPROXIMATE COST OF ONE CRIB ABUTMENT.

5000 feet board measure timber at \$30.	\$150.00
16 piles 30 feet long each = 480 feet at 20 cts.	96.00
500 pounds iron in above at 5 cts.	25.00
Back filling, etc.	29.00
Total	\$300.00

Tunnels.

Any tunnel work will usually require a special survey and careful investigation before being undertaken.

They are generally built straight, and are usually dug from each end.

The construction depends on the nature of the material; in very soft ground a circular cross section is used or an inverted arch along the bottom with tapering sides and a semi-circle along the top.

The general construction is usually a rectangle with a semi-circle or semi-ellipse top, lined on the inside and graded throughout its length so as to drain with open gutters on the sides.

When wood lining is used it is made extra wide so as to allow for a permanent lining at a future date.

Any crevices made by the material falling outside of the construction line are filled with dry broken stone, rock, or split cord wood.

When intermediate shafts are built they are generally closed up when the tunnel is complete, as they tend to produce cross currents of air, which retard ventilation. The movement of the train through the tunnel is said to be the best ventilator. In long tunnels power-driven fans are sometimes used.

The ordinary wood or rock tunnel sections in common use are shown on Figs. 41 and 42, and their average cost is about as follows:

Fig. 41, Post section with lagging:

Excavating 18 cubic yards per lineal foot.

Timber, 450 feet B. M. per lineal foot.

Cost per lineal foot \$45 to \$55 without track or ballast.

Post section without lagging:

Excavating 18 cubic yards per lineal foot.

Timber 350 feet B. M. per lineal foot.

Cost per lineal foot \$35 to \$45 without track or ballast.

Fig. 42, Rock section:

Excavating 14 cubic yards per lineal foot.

Cost per lineal foot, \$50 to \$65 without track or ballast.

Portals. — The end portals for the tunnel consist of $12'' \times 12''$ posts spaced 2-foot centers for a distance of 8 feet from the ends, with $12'' \times 12''$ timbers built over and across the end posts, to form retaining wall on top; the end walls are also braced with

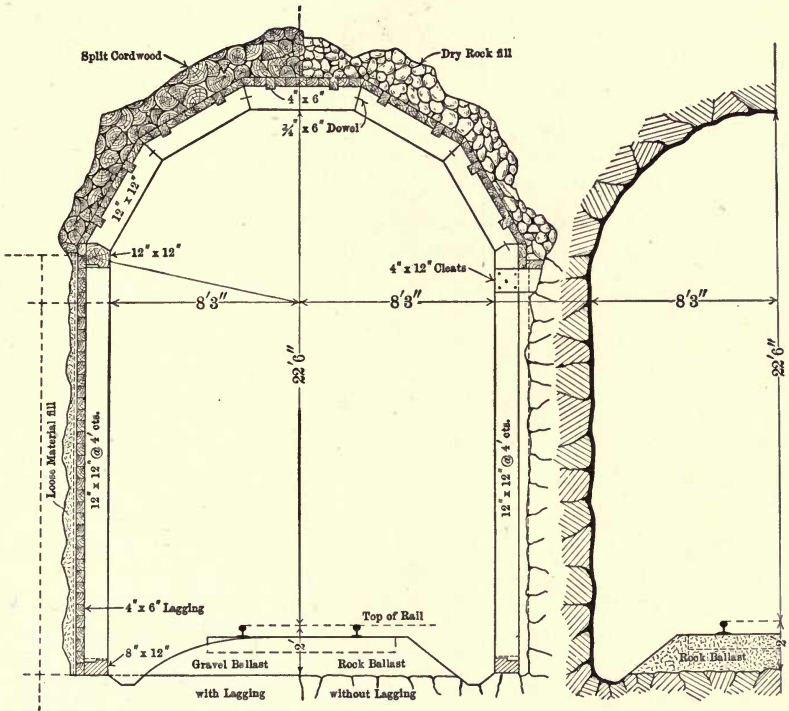

Figs. 41 and 42. Tunnels.

$12'' \times 12''$ timbers forming wing walls running parallel with the track at an angle of 45 degrees at one-third and two-thirds the height with lining behind if necessary to take the end slope of the hill; the brace posts are secured at the bottom by extending the main sill.

The timber in the portal as described above would be 3000 feet B. M. per foot for the last 8 feet of the tunnel at either end. The

length of extra timbering and wing walls to form portals will vary to suit each individual case, 8 feet being the minimum.

TABLE 38. — COST FIGURES FROM DRINKER'S "TUNNELING."

Material.	Cost per cubic yard.				Cost per lineal foot.	
	Excavation.		Masonry.		Single.	Double.
	Single.	Double.	Single.	Double.		
Hard rock.....	\$5.89	\$5.45	\$8.25	\$12.00	\$69.76	\$142.82
Loose rock.....	3.12	3.48	9.07	10.41	80.61	119.26
Soft ground.....	3.62	4.64	10.50	15.00	135.31	174.42

CHAPTER V.

BUILDINGS.

Tool Houses.

In the maintenance of track the road is divided into sections ranging from 4 to 8 miles or thereabout, each section being looked after by a gang of men under a foreman who is responsible for its safety to the roadmaster. A tool house to hold the hand car and tools is usually provided for each section, and is generally located on the right of way close to a public road, or near a station, and within easy reach of the section foreman's house; it is set back far enough so that the hand car can be pulled out to stand clear of the tool-house door when open, and passing trains, placed when possible alongside the main track clear of switches.

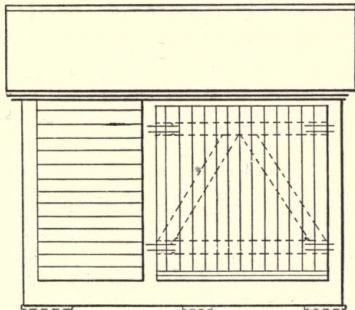

Single Tool House.

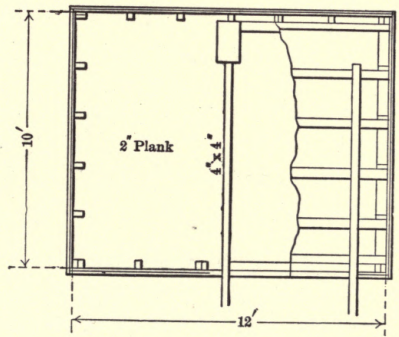

Plan Single House.

Fig. 43.

The minimum distance should not be less than 9 feet from the nearest rail.

Approximate Cost.

Fig. 43, **single**, 10 feet wide, 12 feet long and 7 feet high, erected complete, \$65 to \$90 each.

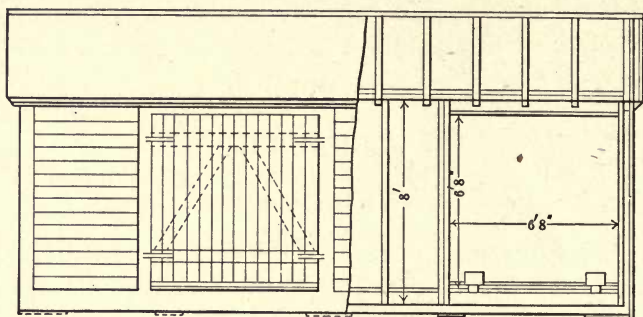

Double Tool House.

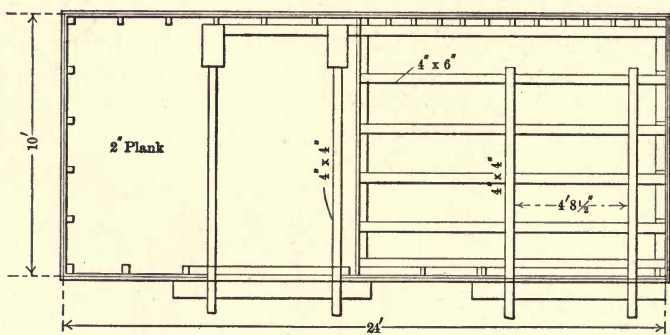

Plan Double House.

Fig. 44.

Fig. 44, **double**, 10 feet wide, 24 feet long and 7 feet high, erected complete, \$125 to \$170 each.

Construction. — Plank or cedar sill foundation for flat ground, and cedar posts 6-inch diameter about 5-foot centers, or old bridge stringers, when on sloping ground.

Sill 4"×4" all round the outer walls, joists 4"×6" at 2-foot centers, covered with 2-inch plank.

2-inch by 4-inch studs, 2-foot centers doubled at door openings and all corners, 4"×4" wall plates 7 feet high from floor, outside boarded with 7/8-inch rough plank finished with seven-eighths ship lap or drop siding with 1"×5" planed, top, bottom and corner boards.

Rafters, 2-inch by 4-inch, 2-foot centers, one-third pitch roof covered with 7/8-inch rough boards and shingles with building paper between, gable ends.

A small window is provided at each end, a double door facing the track, opening outwards, about 7 feet wide, with stringers and light platform from the house to the track, for convenience in taking the hand car out and in. The door is provided with chain staple and switch padlock.

Double Tool House.—A double tool house is usually two single tool houses under one roof, built when a single house is considered too small, or when circumstances make it convenient to have two gangs at one point.

Approximate estimates of cost.

SINGLE TOOL HOUSE.

Quantities.	Material.	Labor.	Total Unit.	Cost.
2000 ft. B. M. lumber per thousand ft. B. M.	\$17.00	\$13.00	\$30.00	\$60.00
2000 shingles per thousand.....	2.00	2.00	4.00	8.00
Hardware and glass	3.00	2.00	5.00
Painting.....	5.00	7.00	12.00
Total.....	\$85.00

DOUBLE TOOL HOUSE.

Quantities.	Material.	Labor.	Total unit.	Cost.
3500 ft. B. M. lumber per thousand ft. B. M.	\$17.00	\$13.00	\$30.00	\$105.00
4000 shingles per thousand.....	2.00	2.00	4.00	16.00
Hardware and glass	6.00	4.00	10.00
Painting.....	9.00	12.00	21.00
Total.....	\$152.00

STANDARD SIZES OF TOOL HOUSES ON VARIOUS RAILROADS.

Pennsylvania.....	16 ft. by 30 ft.	Philadelphia and
Pennsylvania.....	16 ft. by 20 ft.	Reading.....
Pennsylvania.....	12 ft. by 14 ft.	Canadian Pacific and
Cincinnati Southern	12 ft. by 16 ft.	Northern Pacific
Union Pacific.....	10 ft. by 14 ft.	Canadian Pacific and
Atchison, Topeka &		Northern Pacific
Santa Fe.....	12 ft. by 16 ft.	Lehigh Valley.....

* Double.

† Single.

Tool Equipment.

Tools to supply every man in the gang and several extra for repair purposes are required, for each section.

The kind of tools used vary according to the ballast and other conditions, and the following is an average list of the minimum equipment for section gang of foreman and three men:

Adzes.....	2	Handles, pick.....	2
Axes.....	1	Jack track.....	1
Bars, claw.....	2	Lanterns.....	4
Bars, crow.....	2	Levels, spirit pocket.....	1
Bars, lining.....	2	Levels, track.....	1
Bars, tamping.....	2	Oil can.....	1
Boards, elevation.....	1	Oiler.....	1
Brooms.....	1	Oil (signal), pints.....	4
Cars, hand.....	1	Padlock, key, and chain.....	2
Cars, push.....	1	Pail, water.....	1
Chisel rail.....	5	Picks and handles.....	4
Cup, tin.....	1	Platform dumping for push cars.....	1
Flags, red.....	2	Ratchet and 3 drills.....	1
Flags, yellow.....	2	Rail tongs.....	2
Grindstone.....	1	Saws, hand.....	1
Gauge, track.....	1	Saws, cross cut.....	1
Globes, red.....	2	Scythe, complete, grass or brush.....	1
Globes, white.....	2	Shovels, track.....	6
Globes, yellow.....	2	Switch key.....	1
Hammers, maul.....	2	Tape, 50 feet.....	1
Hammers, nail.....	1	Template, standard roadbed.....	1
Hammers, sledge.....	1	Torpedoes.....	12
Handles, adze.....	1	Wrenches, monkey.....	1
Handles, axe.....	1	Wrenches, track.....	3
Handles, maul.....	2		

Approximate cost.

1 car, hand.....	\$40.
1 car, push.....	30.
1 car, dump platform.....	21.
1 rail blender.....	27.
1 rail drill.....	25.
Balance as per list.....	182.
Total.....	\$325.

Watchman's Shelter.

When it is necessary to have a watchman to operate gates or look after crossings, a wood shelter or shanty is usually provided for the convenience of the flagman, usually located at one side of the crossing, on the right of way, set well back so as not to obscure the view from approaching trains.

Approximate Cost. — Five feet wide, 7 feet long, and 7 feet high from floor to wall plate (flatted cedar sill foundation), \$65 to \$75.

Construction. — Six-inch flatted cedar sill foundation, at 2-foot 6-inch centers.

Two-inch by 4-inch joists 1-foot 9-inch centers with $\frac{7}{8}$ -inch T. and G. rough board and $\frac{7}{8}$ -inch finished floor with tar paper between.

Two-inch by 4-inch studs, 1-foot 9-inch centers doubled at corners with 4"×4" top and bottom plates, covered with $\frac{7}{8}$ -inch T. and G. boards and $\frac{7}{8}$ -inch ship lap or drop siding with paper between, on the outside, and sheathed inside with $\frac{7}{8}$ -inch material.

Roof one-third pitch, gable ends, 2"×4" rafters 1-foot 9-inch centers with 1"×4" ties and wall plates, covered with two layers $\frac{7}{8}$ -inch boards with paper between and shingles on top.

One window in each end and one side, and door with sash at other side, locker, seat and small coal bin including 6-inch cast-iron smoke jack.

Approximate estimate of cost.

Quantities.	Material.	Labor.	Total unit.	Cost.
1000 ft. B. M. timber per thousand ft. B. M.....	\$18.00	\$17.00	\$35.00	\$35.00
Hardware.....	4.00	2.00	6.00
Glazing and painting..	4.00	6.00	10.00
800 shingles per thousand	2.00	2.00	4.00	3.20
One 6-in. C. I. smoke jack and flashing.....	3.80	2.00	5.80
Coal bin, seat and locker.....	3.50	1.50	5.00
Total.....	\$65.00

Section Houses.

Section houses are built along the right of way principally for the convenience of having the trackmen live close at hand to readily respond for emergency service at any time. The houses are usually framed structures, and are built single or double; the double houses are convenient at points where it is necessary to keep two gangs.

Single Section House (Fig. 45):

Approximate cost complete.

Cedar sill foundation.....	\$750. to \$ 950.
Masonry foundation and cellar.....	900. to 1200.

Double Section House (Fig. 46):

Approximate cost complete.

Cedar sill foundation.....	\$1400. to \$1750.
Masonry foundation and cellars.....	1700. to 2200.

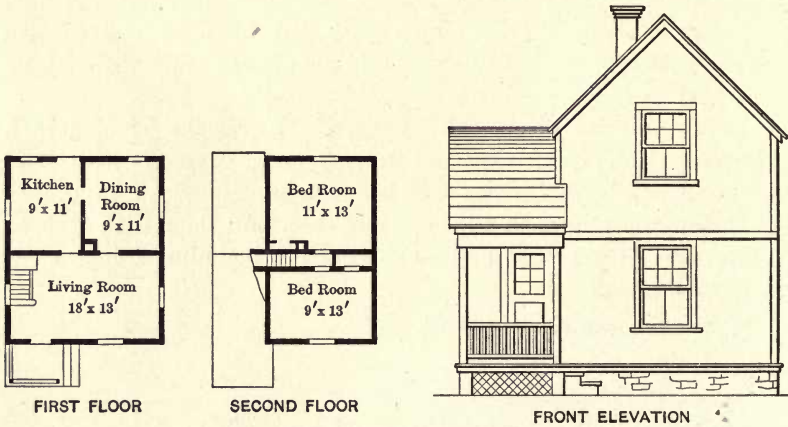
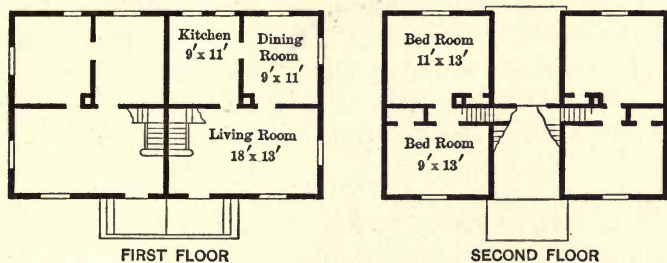

Fig. 45. Single Section House.

Construction. — Frame and partitions, spruce; rough boarding, floors, clapboards, outside and inside finish, frames, etc., good quality native spruce or pine; shingles, pine or cedar; all mouldings, doors, windows, and inside finish, stock pattern.

Cedar sills or posts about 5-foot centers, or when it can be done cheaply, concrete, stone, or brick foundation with cellar. Frame, 2" x 3" studs at 16-inch centers, 2" x 10" joists at 16-inch centers, ceiling roof joists and rafters 2" x 6" at 16-inch centers, 4" x 3" wall plates and runners, outside walls 7/8-inch rough boarding, with

$\frac{7}{8}$ -inch ship lap, siding, or shingles, with building paper between, and 1" \times 5" trim around windows, doors, porch, eaves, etc. All inside walls lathed and plastered. Shingle roof, $\frac{7}{8}$ -inch boards with building paper between. Floors $\frac{7}{8}$ -inch rough boards and $\frac{7}{8}$ -inch finished floor with building paper between for ground floor, and $\frac{7}{8}$ -inch finished floor only for upper story.



FRONT ELEVATION

Fig. 46. Double Section House.

Approximate estimates of cost.

Quantities.	Single house.	Double house.
Excavation and wood foundation...	\$20.00	\$ 35.00
Brick.....	35.00	70.00
Hardware.....	20.00	35.00
Carpentry.....	518.00	953.00
Lath and plaster	82.00	167.00
Shingles.....	25.00	45.00
Painting and glazing	50.00	95.00
	<u>\$750.00</u>	<u>\$1400.00</u>
If masonry foundation, add	150.00	300.00
Total	<u>\$900.00</u>	<u>\$1700.00</u>

Privies.

Where there is no drainage or water system, privies are sometimes built at wayside stations for public or employees' use, usually two compartments 5 feet wide and 7 feet long, with pit and vent.

Wood structure, located generally in close proximity and to one side of the station in some place where it will not be too conspicuous; a lattice screen is usually placed in front.

Approximate cost. (Fig. 47.) — Double compartment 7 feet deep, 10 feet long, about 8 feet high from floor to wall plate.

(Wood sill foundation)..... \$95 to \$125

Construction. — Flatted cedar sill foundation, floor joists 2" × 4" about 2-foot centers, with 1-inch floor boards; frame 2" × 3" studs about 2-foot centers, doubled at corners with 2" × 3" sill plates, and 4" × 3" roof plates, covered with two layers $\frac{7}{8}$ -inch boards. Roof $\frac{1}{2}$ pitch gable ends, 2" × 3" rafters, about 2-foot centers, covered with $\frac{7}{8}$ -inch boards and shingles on top.

Pit, 2-inch plank box about center of house, projecting 2 feet 6 inches from side of house, extending 5 feet in length, 5 feet in width, and 5 feet deep, with lid on top, and 8-inch square vent from pit to roof, with louvre top.

Screen, 2" × 4" posts, 1" × 10" top and bottom plate, $\frac{3}{8}$ " × 1 $\frac{3}{4}$ " cross laths.

One small light at each gable, one door to each compartment, also closet seat 2 feet wide, 1 foot 6 inches high, made of 1 $\frac{1}{2}$ -inch material.

Approximate estimate of cost.

Quantities.	Material.	Labor.	Total unit.	Cost.
2000 ft. B. M., per thousand	\$18.00	\$17.00	\$35.00	\$70.00
2000 shingles, per thousand	2.00	2.00	4.00	8.00
Hardware.....	6.00	4.00	10.00
Paint.....	4.00	6.00	10.00
Vent.....	3.00	2.00	5.00
Total.....	\$103.00

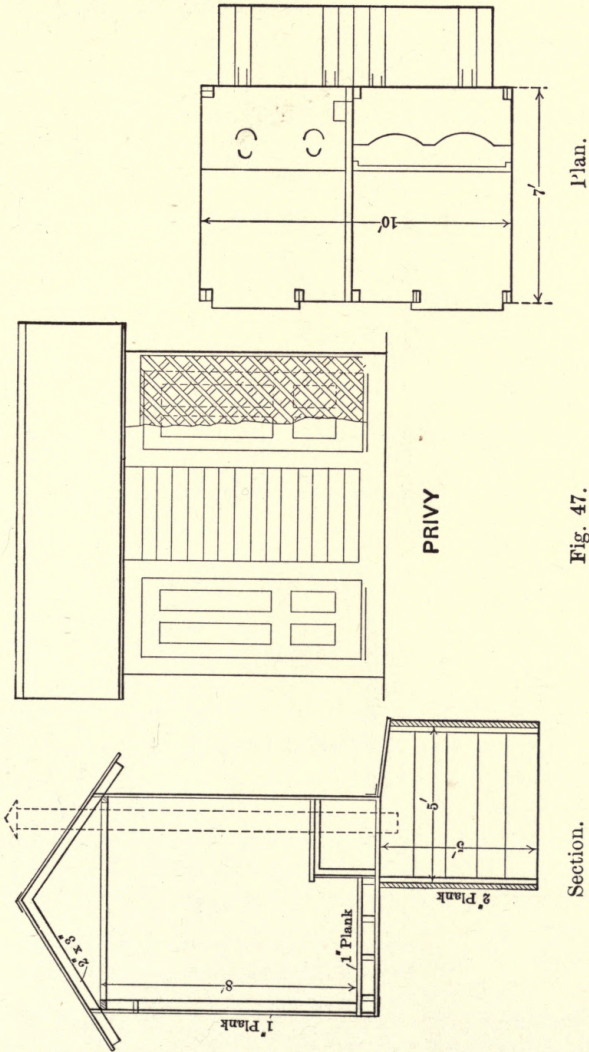

Plan.

PRIVY

Section.

Fig. 47.

Shelters.

Shelters are erected at suburban points where passenger traffic is light.

Approximate Cost.

Fig. 48 complete with platform..... \$125 to \$200.

Fig. 49 complete with platform..... 350 to 450.

Construction. — Foundation cedar sills, frame 2" × 3" studs, 2-foot centers, 4" × 3" wall plates, 2" × 3" ceiling and roof joists, 2" × 6" floor joists at 2-foot centers, covered with 1-inch rough

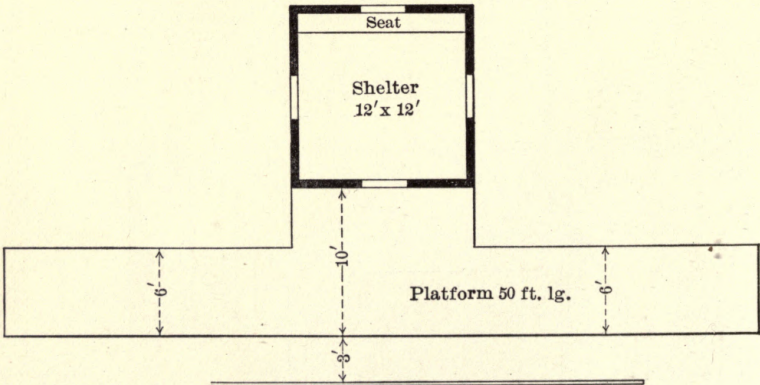
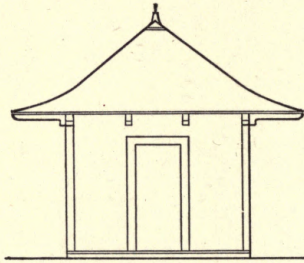

Fig. 48. Shelter Station.

T. and G. boards, and 7/8-inch finished floor on top, with tar paper between, outer frame covered with 7/8-inch rough T. and G. boards, including roof, finished with drop siding and shingles, with tar paper between. Inside walls and ceiling sheathed with 7/8-inch matched boards. All woodwork stained outside and inside.

Platform 5 inches above rail, made of 3-inch plank on cedar sleepers, 7-foot centers.

Extension roof 6" × 6" posts, 4" × 4" brackets, 6" × 6" runners, rafters and roof finished similar to shelter.

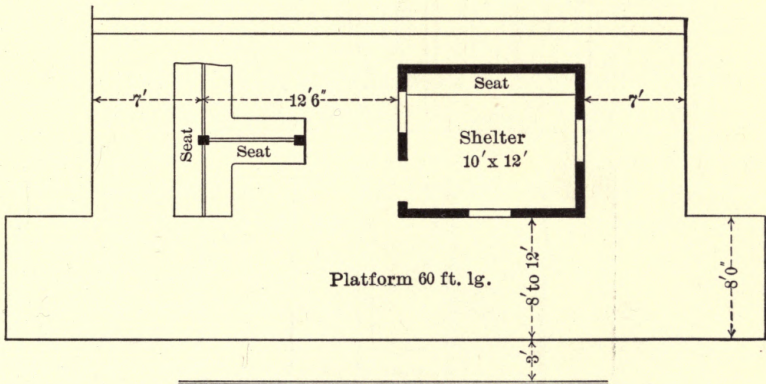
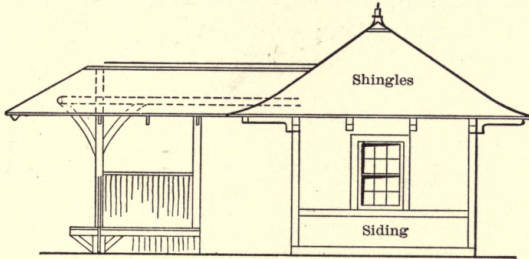

Fig. 49. Shelter Station.

Platform Shelter.—Approximate cost per running foot \$8 to \$12.

Umbrella type of platform shelter 16 feet wide, with main posts 14-foot centers, ridge plate 12" × 2", rafters and ties 3" × 6" with 4" × 3" supports, and 4" × 6" run beams, roof covered with 1½-inch matched boarding, and galvanized iron, ready roofing or shingles on top; the main posts are supported on round, flatted cedar sills about 6 feet below the platform, braced both sides, and held laterally by the platform joists. The platform is made of 3-inch plank on top of 11" × 3" joists on split cedar sills at about 7-foot centers.

Stations.

The following frame stations range in price from \$1000 to \$3500, which is about the average run of ordinary way stations. They are not submitted as ideal schemes, but simply as suggestions as to size and cost in a general way, that may be varied as desired.

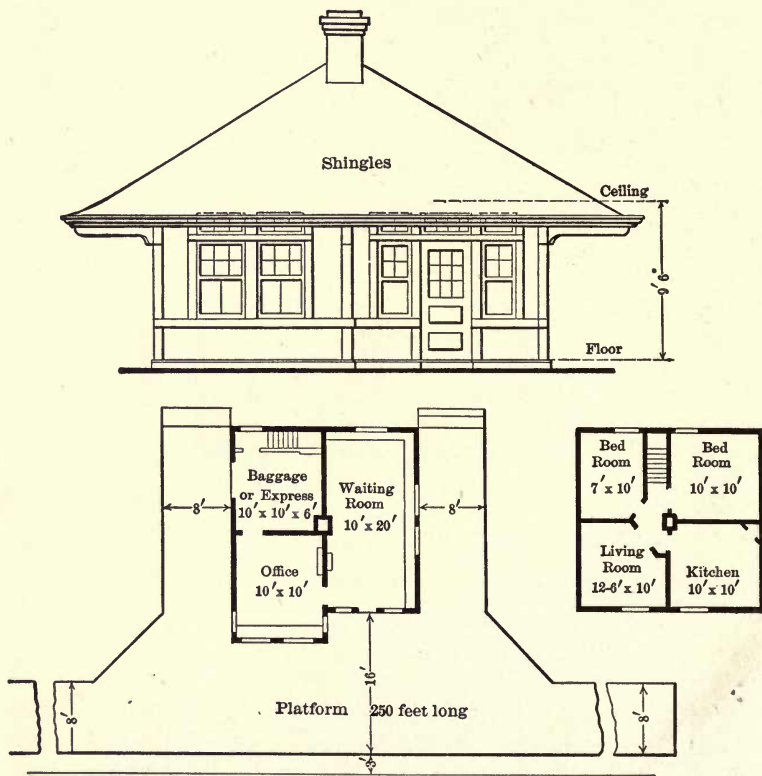

Fig. 50.

Fig. 50, station with waiting room 10×20 feet, office 10×10 feet, and baggage or express room $10 \times 10\frac{1}{2}$ feet. Height from floor to ceiling $9\frac{1}{2}$ feet.

Approximate cost with platform complete:

Cedar posts or mud sill foundation \$1000 to \$1300
 Masonry foundation with cellar 1250 to 1500

Figs. 50 and 51, station similar to the above, with agent's dwelling over.

Approximate cost with platform complete:

Cedar post or mud sill foundation \$1500 to \$1700
Masonry foundation with cellar 1800 to 2000

Fig. 52, station similar to Fig. 50, with a freight room added.

Approximate cost with platform complete:

Cedar post or mud sill foundation \$1400 to \$1700
Masonry foundation with cellar 1650 to 1800

Fig. 53, station with waiting room 16 × 16 feet, ladies' waiting room, 10 × 20 feet, office 12 × 10 feet, baggage and express 16 × 16 feet, with corridor between general and ladies' waiting room, and lavatory accommodation in the rear.

Approximate cost with platform complete:

Cedar post or mud sill foundation \$2000 to \$2500
Masonry foundation with cellar 2400 to 2600

Fig. 54, station with waiting room 16 × 16 feet, ladies' room 10 × 10 feet, office 10 × 13 feet, baggage or freight 16 × 16 feet, with kitchen and living rooms in the rear and four bedrooms above.

Approximate cost with platform complete:

Cedar post or mud sill foundation \$2500 to \$2800
Masonry foundation with cellar 3000 to 3500

Construction. — Cedar sills, post or masonry foundation, brick chimneys, 2" × 4" studs 16-inch centers for outside walls, and 2" × 3" studs at 16-inch centers for inside partitions. Ceiling joists and roof rafters 2" × 8" at 2-foot centers, well tied and secured to wall plates. Outside walls and roof to be covered with $\frac{7}{8}$ -inch T. and G. boards and finished with ship lap, clapboards or shingles, with building paper between.

All inside walls and ceilings lath and plastered, and rooms finished with baseboard and picture mould, with architraves, sills, thresholds, and general trim for doors, windows, and other openings. Waiting-room walls burlapped 6 feet high, and

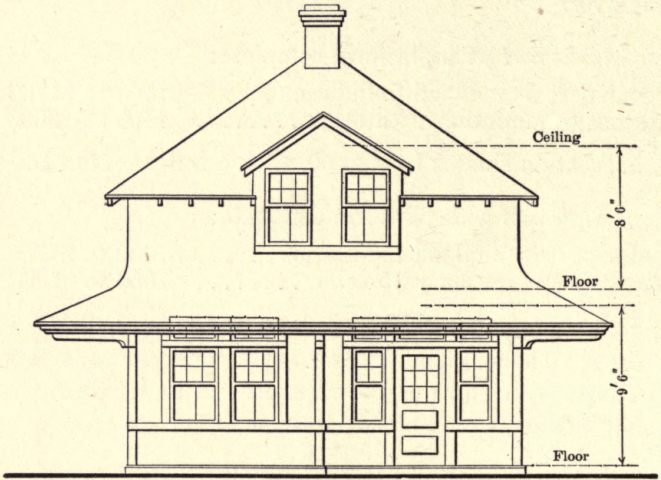

Fig. 51.

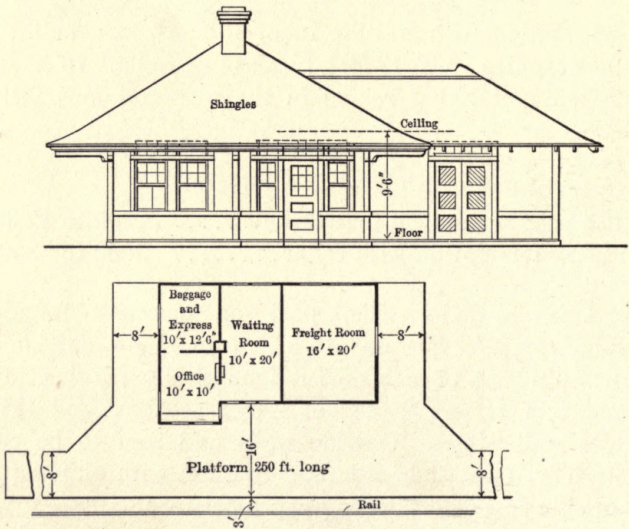

Fig. 52.

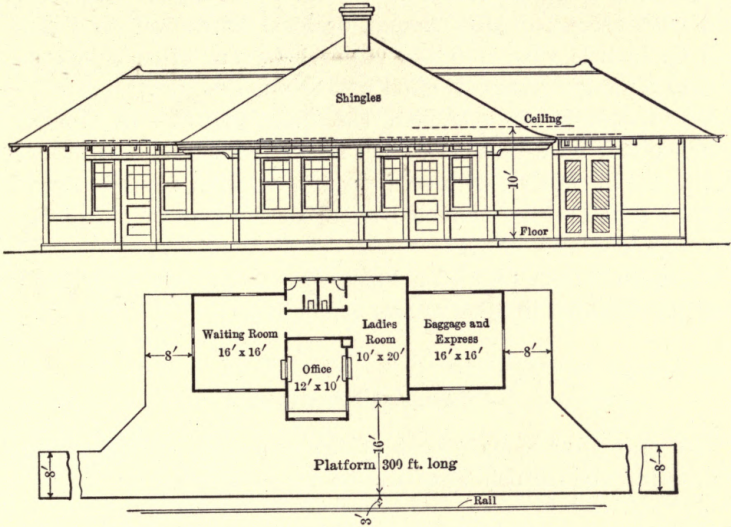

Fig. 53.

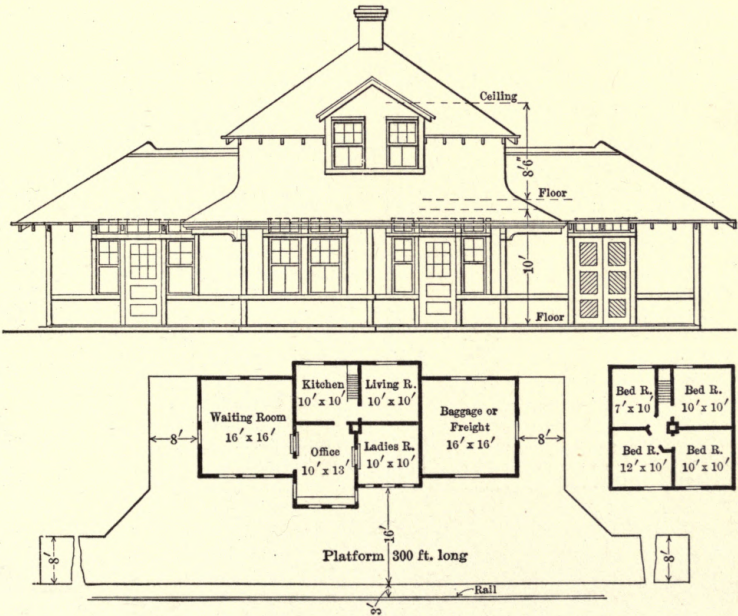

Fig. 54.

freight and baggage rooms sheathed 8 feet high. Ground floor laid with second quality maple, or local hardwood on $\frac{7}{8}$ -inch T. and G. boards with building paper between, other floors $\frac{7}{8}$ -inch T. and G. narrow boards, good native pine.

When cellars are provided the floor may be of cement or 2-inch plank on 3-inch to 6-inch flatted cedars at 4-foot centers, embedded in cinders, with coal bin and chute in approved position so that coal may be shoveled from car at level of platform and run by gravity to cellar.

Platform 3-inch plank on heavy cedar sleepers at 4-foot centers, well bedded in good gravel or cinders.

Station Furniture.

List and approximate cost of the principal articles generally required in the furnishing of an ordinary way station:

Arm chair.....	\$ 2.50	Mop handle.....	\$.10
Baggage truck (3 wheel)....	21.00	Oil can, 5 gallons.....	1.35
Battery jar.....	.20	Oil-can, 2 gallons.....	.40
Bracket lamp.....	1.25	Oil-filler.....	.15
Broom.....	.30	Platform lamps.....	1.40
Bulletin board.....	3.00	Platform scale.....	32.00
Cash till.....	3.50	Safe..	135.00
Coal scuttle.....	.35	Scrub brush.....	.20
Copying press.....	12.50	Settees, seats, or chairs....	variable
Desk for office.....	12.00	Window blinds.....	1.50
Desk for operator.....	12.00	Set planks for unloading	
Dustpan.....	.15	freight.....	10.00
Fire pails.....	.40	1 stand, zinc lined, for	
Fire extinguisher.....	11.00	wringer.....	12.00
Fire shovel.....	.25	1 stationary cabinet.....	17.00
Flag, green.....	.06	1 step ladder.....	1.20
Flag, red.....	.06	Stove and pipes.....	15.00
Flag, white.....	.06	Table.....	7.00
Funnel.....	.06	Table lamps.....	.20
Gang plank.....	2.50	Towel rack.....	1.25
Hammer.....	.40	Water pails.....	.65
Hand axe.....	.90	Water cooler.....	2.50
Hand saw.....	.35	Wick trimmer.....	.30
Ticket case.....	6.00	Wringer.....	2.80
Lantern, red.....	1.15	Pinch bar.....	.95
Lantern, white.....	.60		

Platforms.

Freight Platforms. — At points where the freight shed is at one end of the station building, either as an extension or a separate building on the main line, it is impossible to unload car-load freight or heavy machinery. On this account it is sometimes necessary to erect unloading platforms on the siding delivery track, where machinery or car-load freight can be handled.

The platforms vary in width from 8 to 24 feet or more, and should not be less than a car length, or about 30 feet, with a ramp at one end.

Approximate cost. — The cost of such platforms varies from 25 cents to 50 cents per square foot erected complete.

Grain Loading Platforms. — Grain loading platforms are erected where grain is shipped from teams to cars. They are built 4 feet above rail, with a grade of one in ten on the up side, and one in six on the down side, supported on posts 8 to 12 feet apart longitudinally and about 5 to 6 feet cross ways, with 10"×10" caps over and 3"×10" joists covered with 3-inch plank.

A platform 18 feet wide, with ramps, 100 feet long, with 8 × 10 rail on the track side and a hand-rail on the opposite side, will cost approximately \$7 per lineal foot.

An earth platform of the same dimensions can sometimes be built very cheaply by using old bridge stringers to retain the fill on the track side, tying it back with old ties, the filling sloping 1½ to 1 on the opposite side.

Freight Sheds.

When posts are not objectionable inside the house, the flat roof construction is probably the simplest and cheapest for this class of building.

In long wooden sheds, brick gable walls are built at each end, and at intervals of 50 to 100 feet fire walls are inserted, the walls being carried 12 to 24 inches above the roof, capped with a coping of concrete, stone, or tile.

Hand sprinklers and fire hydrants are also introduced throughout the house for fire protection, and in many cases the sprinkler system is installed. This consists of a series of main and branch water pipes. The mains are carried up at frequent intervals, and the branches are carried across the ceiling fairly close, and equipped with sprinkler heads that automatically open when the temperature exceeds a certain limit. Scales are also provided to weigh freight when desired.

Fig. 55 illustrates a 32 feet wide shed, 14 feet high, with trucking platform on track side, posts 16-foot centers both ways. The doors on the track side can be hung on a double trolley track overhead, so that they may slide by each other, or on sheaves, with counterweights, to slide up similar to the ordinary English window. The doors on the road side may be 16-foot or 32-foot centers, the balance of the construction as per sketch.

Approximate cost. — \$1.00 to \$1.40 per square foot (concrete floor) or \$32.00 to \$45.00 per running foot (concrete floor), or 5 to 7 cents per cubic foot (concrete floor).

Fig. 56 illustrates a 40 feet wide shed, 14 feet high, without platforms, with two inner rows of posts at 16-foot centers either way. The roof joists towards the track side are cantilevered out 8 feet and carry the doors and lights over. With this arrangement, and the doors hung on a double trolley track, so that they slide past each other, there are no posts to interfere with car doors, and truck platforms are not necessary. The balance of the construction is shown on the sketch.

Approximate cost complete. — \$1.20 to \$1.50 per square foot (concrete floor), or \$48 to \$60 per running foot, or 6½ to 9 cents per cubic foot.

Fig. 57 illustrates a 52 feet wide freight shed with platforms both sides, wood floor and overhanging roofs. The front posts are 8" x 10" at 8-foot centers, the inner posts 8" x 10" at 16-foot

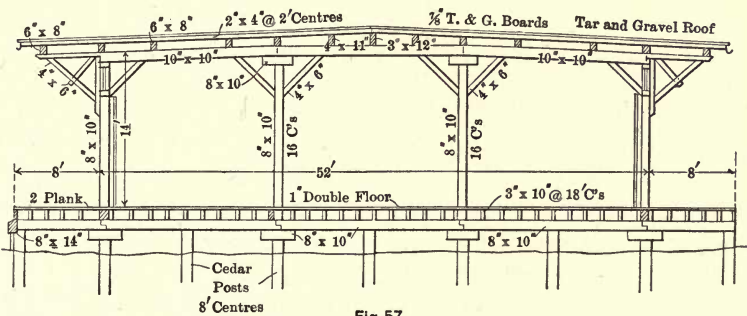
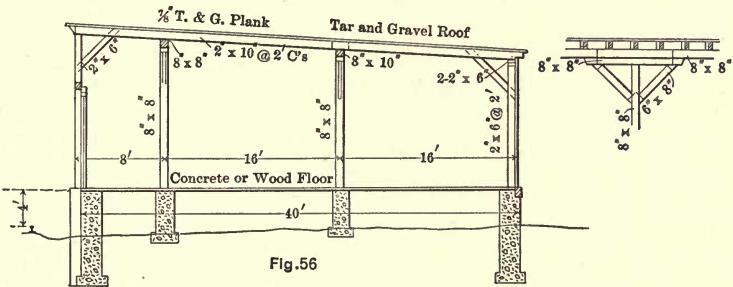
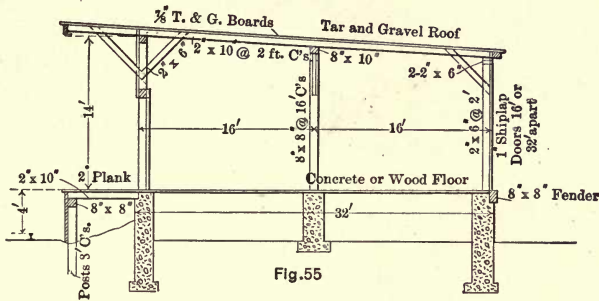

Freight Sheds.

centers. The doors on both sides are placed 32-foot centers, and are hung on pulleys and weights similar to the English sash windows, so as to slide up. The balance of construction is shown on the sketch.

Approximate cost complete. — 75 cents to \$1.00 per square foot of building, or \$38.00 to \$52.00 per running foot, or 3 cents to 4 cents per cubic foot of building.

Freight sheds, 25 cents to 50 cents per square foot. When covering a large area with suitable ground, so that the floor rests on natural soil, construction 6" × 8" posts, 16-foot centers across and along the house, the posts resting on cedar sills.

The main roof beams are 8" × 10", corbeled over the posts and bracketed at each side, the rafters 2" × 8" at 2-foot centers, with 1" × 2" bridging, 7/8-inch roof boards on top, and finished with tar and gravel or ready roofing. The posts are held crosswise by 2" × 4" braces.

The floor is second quality hardwood on 7/8-inch rough boards, with tar paper between, on 3 to 6-inch flatted cedar sills embedded in the ground.

A wood-built wall of 6-inch cedar posts and 3-inch planks is made along the track sides. The doors are hung on a double trolley track so as to slide past each other.

Freight shed, 50 to 75 cents per square foot. This is somewhat similar to above, excepting that the floor is raised about 4 feet above the natural ground.

Paving Freight Shed Teamways.

Approximate cost. — Paving, including filling excavation and gutters per square yard, \$2.25 to \$3.25. Concrete curbing 1 foot wide by 1 foot 6 inches deep, per lineal foot in place, 60 cents to \$1.00. 12-inch vitrified tile drain pipe in place, per lineal foot, 75 cents to \$1.00.

Grading. — Roadway excavated or filled or both to insure a good foundation and to conform with subgrade.

Excavate for the curbing to such depths as may be required to properly set the same and insert a bed of broken stone 3 or 4 inches thick before concreting. Fill to subgrade with good gravel, thoroughly pounded, or rolled, and water if necessary before rolling, all soft material to be removed before filling, surplus material to be deposited as directed or removed.

Paving. — Over the prepared subgrade, lay a bed of clean sharp sand, not less than 1½ inches or more than 3 inches

thick, well watered and rolled to a hard surface, to established levels.

Blocks to be $4\frac{1}{2}'' \times 5\frac{1}{2}'' \times 10''$ to $15''$ long or thereabout, free from cracks or defects, laid in straight lines and in close contact at sides and ends, to break joints at least 3 inches, each row tightened from end to end before closure is inserted.

The whole when laid to be well rammed and rolled and brought to a true cross-section, and the joints filled with sand.

Drainage. — 12-inch tile pipe connecting with manhole, laid to established grades with cement joints.

Engine Houses.

The ordinary engine house in common use is a circular building, Fig. 58, divided into stalls, and is generally termed the roundhouse. They are erected at divisional and other points where convenient, for the housing of engines when out of service, and are built of wood, brick, stone, or concrete.

The building is located generally about the center of the yard, sufficiently far over to be clear of possible yard expansion. In cities and towns, where land is limited, the house has to be placed as will best suit local conditions.

The size of engine houses varies from 60 to 100 feet in depth. An 85-foot house, which is about the average, would have the following dimensions, using a 70-foot turntable:

Center of turntable to front face of engine house	95 ft. 2½ in.
Center to center front door posts	13 ft. 7 in.
Length from front face to back face of back wall . . .	85 ft. 0 in.
Width center to center back wall pilasters	25 ft. 10 in.
Height of front, from base of rail to roof	24 ft. 0 in.
Height of back, from base of rail to roof	19 ft. 0 in.
Engine doors	12 ft. 6 in. × 17 ft. 0 in.

The area of one stall as above is approximately 1700 square feet, and the cubic capacity about 34,000 cubic feet.

Approximate cost. — Approximate cost per stall for various designs, dimensions as above:

(1) *Frame building:* Wood posts, cinder floor, *cedar sill foundation*, wood roof, \$1600 to \$1800. Average, \$1 per square foot, or 5 cents per cubic foot.

(2) *Frame building:* Wood posts, cinder floor, *masonry foundation*, wood roof, \$2000 to \$2200. Average, \$1.25 per square foot, or 6½ cents per cubic foot.

(3) *Brick building:* wood posts, cinder floor, *masonry foundation*, wood roof, \$2400 to \$2600. Average, \$1.50 per square foot, or 7½ cents per cubic foot.

(4) *Brick building:* steel and concrete posts, cinder floor, *masonry foundation*, mill construction roof, \$2800 to \$3000. Average, \$1.75 per square foot, or 8½ cents per cubic foot.

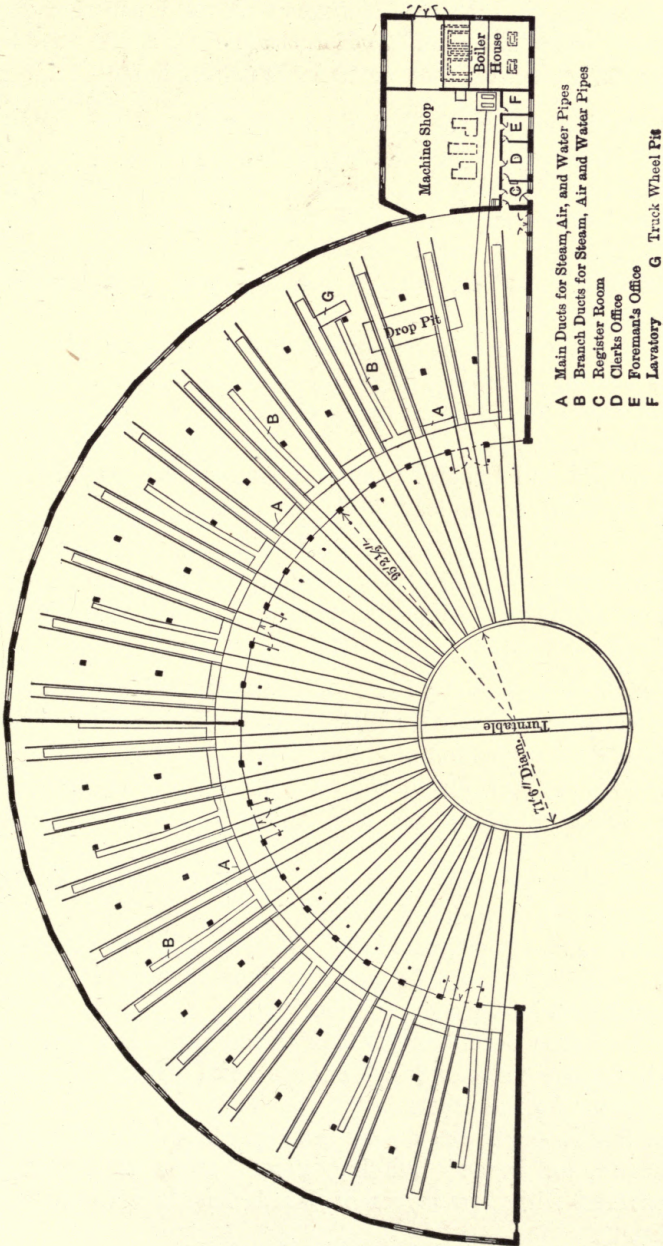

Fig. 58. General Layout, Engine House, etc.

(5) *Masonry or concrete building*: steel and concrete posts, brick floor, cedar sill foundation, *concrete roof*, \$3200 to \$3500. Average, \$2 per square foot, or 10 cents per cubic foot.

The wood roof for the first three estimates would consist of ordinary joists with double $\frac{7}{8}$ -inch boarding on top.

The mill construction roof would consist of large wood beams, spaced at least 8-foot centers with 3-inch plank on top.

The concrete roof would consist of reinforced concrete beams at least 8-foot centers, with 3-inch concrete over, reinforced with expanded metal.

The above costs are for building one stall complete, and include heating, electric wiring and lights, steam, air and water pipes, smoke jacks, drainage inside the house, etc., as per detailed estimate on page 124.

The boilers and boiler house with engine and machine room are not included; see under "Boiler Houses."

Construction. — A brief description of the work, in connection with the building of the engine houses, on which the estimates are based is as follows:

Foundations. — Masonry back walls 24 inches thick, with 12-inch footing courses projecting 6 inches on each side of wall and 5 feet deep from floor to bottom of foundation.

Piers. — Piers for inside columns, footing 3 feet square, 18 inches thick, with cap on top 2 feet square by 18 inches thick.

Outside piers for front columns; footings 4 feet square, 4 feet deep, with square top, 1 foot thick.

Front Walls. — Sometimes brick, stone or concrete pilasters or pillars are built with arches over the door openings. A steel or wood column is better construction.

For the house described 12"×12" wood posts are figured for frame buildings, and two 8-inch channels and one $\frac{3}{8}$ -inch plate for steel columns for the others.

Back Walls. — The back walls are built in wood, brick, stone, or concrete, for framed building, 2"×6" studs at 2-foot centers, covered with two layers of $\frac{7}{8}$ -inch boards with tar paper between.

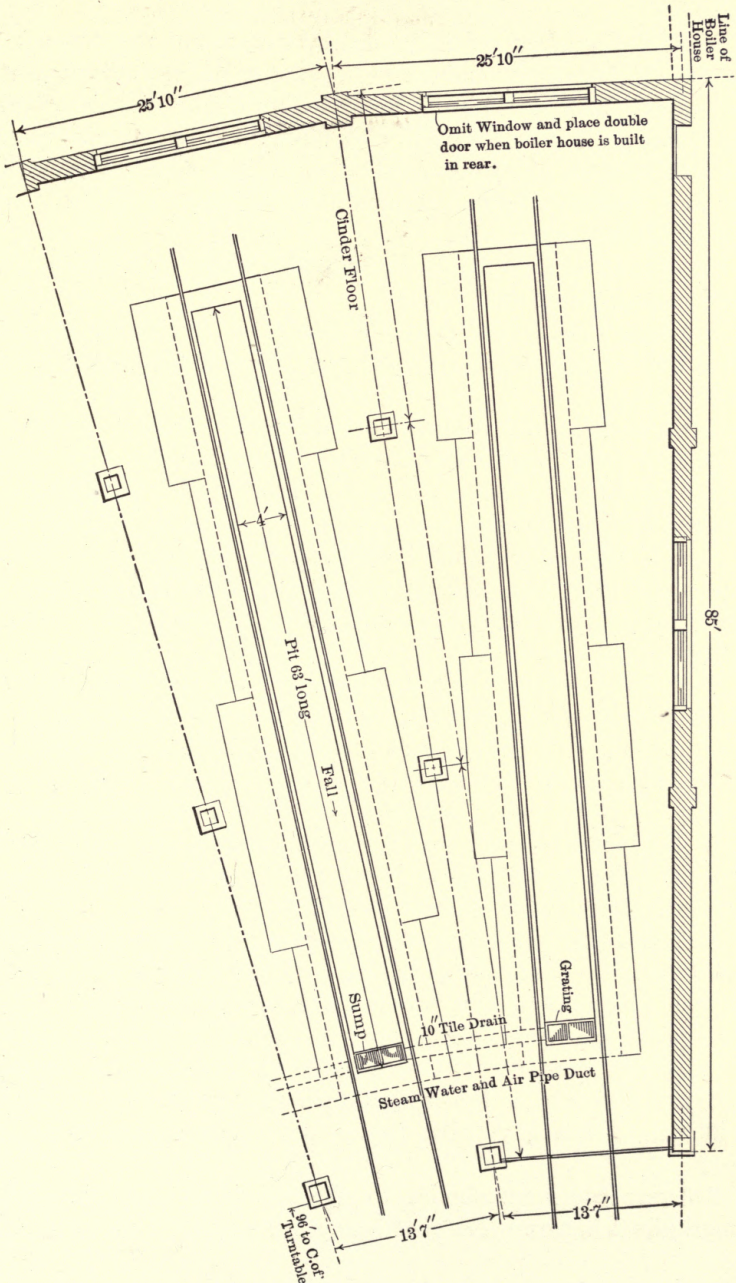

Fig. 58a. Engine House Plan.

Brick walls, unless specially hard burnt, are not recommended, as the smoke fumes and gases from the engines disintegrate soft brick. They are built 13 or 17 inches thick. Concrete walls are usually 14 inches thick, with large pilasters at the intersections of each bay to carry the longitudinal beams supporting the roof timbers. When columns are used in the wall the pilasters can be dispensed with.

Stone walls are usually 18 to 20 inches thick, with pilasters at the intersections of each bay.

Windows with double lights 12' 6" \times 14' 6", about, are built in the center of each stall in the back wall, window sill 2 feet 6 inches to 3 feet high.

Columns. — Inside columns are 12" \times 12" timbers for wood posts and two 6-inch channels with lattice bars for steel posts, with angle iron braces on each side. Where steel is used they are encased in concrete.

End Walls. — End walls built similar to back walls, divided into three bays with two pilasters 2 feet wide and 4-inch projection to stiffen the wall laterally; windows are usually inserted similar to back wall.

Fire Walls. — Fire walls are usually brick or concrete 13 or 14 inches thick, with stiffening pilasters similar to end walls. A fire door 3' \times 7' is provided at one end, and the wall is carried 18 to 24 inches above the roof.

Roof. — For frame buildings 12" \times 12" longitudinal beams over the columns with corbels and brackets over the posts, 2" \times 12" joists at varying centers to suit span, with two $\frac{7}{8}$ -inch layers of timber over, and tar paper between.

Mill construction. — Fig. 59, for brick, concrete, or masonry buildings: The longitudinal beams over the columns are of steel 18 inches high, 55 pounds per foot, with brackets over posts. The steel posts and beams are incased in concrete. The roof timber beams vary from 6" \times 12" to 8" \times 16" at about 8-foot centers, and are covered on top with 3-inch narrow T. and G. plank well nailed laterally with heavy cut nails about 18 inches apart.

Concrete roofs are similar to the above for the posts and longitudinal beams. The roof beams are about 8-foot centers, of

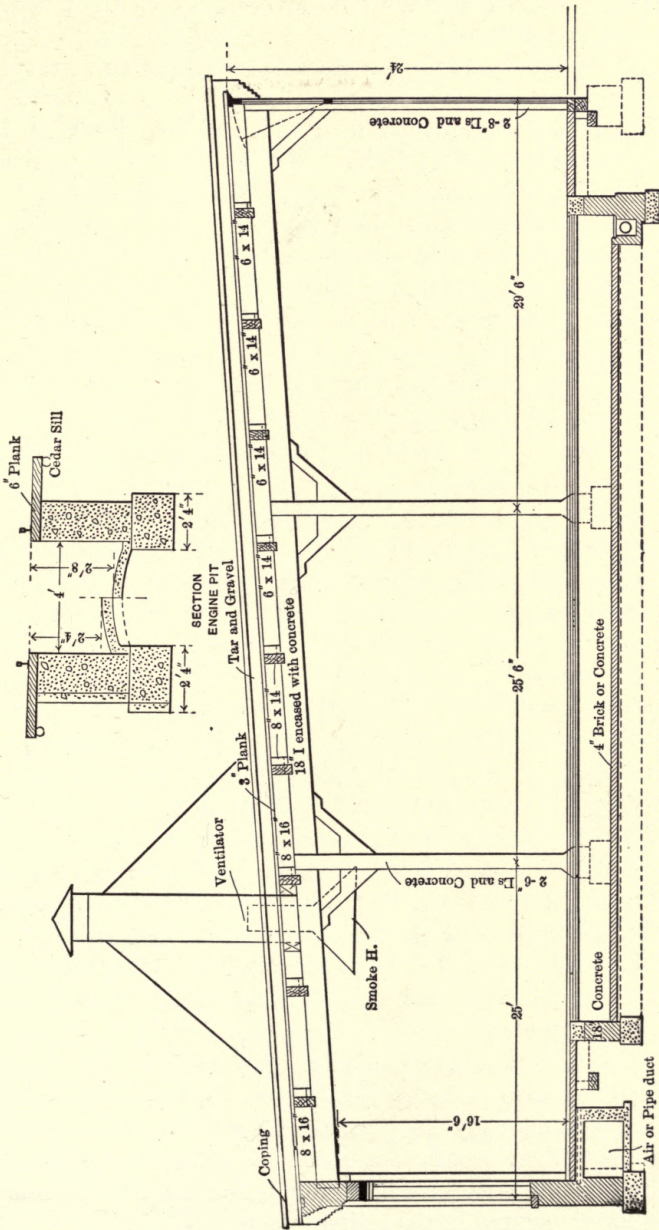

SECTION ENGINE HOUSE

Fig. 59.

reinforced concrete, and the roof covering 3 inch thick concrete with expanded metal.

All of the above roofs are covered with tar and gravel for weatherproofing.

Engine Pits. — Length 63 feet, width 4 feet, depth at back 2 feet 4 inches, depth at front 2 feet 8 inches. Concrete walls 17 inches thick with 1 foot 6 inches thick footing courses 24 inches wide. The rails are laid on 6-inch plank 3 feet wide, on the top of concrete walls, with cedar sills where the plank projects over the walls. The 6-inch planking is built out at both ends to provide for jacking, extra cedar sills at close intervals being used for supporting the plank.

The floor of the pit may be 4-inch brick or concrete, built convex, with a 4-inch rise. The sump hole is 12 inches wide by 12 inches deep across the pit at the low end, with grating over to provide for drainage.

Drop Pit. — The drop pit is usually built between and connects two engine pits in convenient position so that the driving wheels can be taken off and lowered and removed. The pit has to be large enough to take the largest drivers, which is done by removing the portion of rail and its support spanning the pit under the wheel and lowering the wheel by jacks. The use of the telescope jack for this purpose does not require the pit to be much deeper than the ordinary engine pit. In the estimates given the drop pit is 7 feet 6 inches wide and 5 feet 6 inches deep, with truck rails on floor of pit at 2 foot 9 inch centers on 5"×8" ties at 3-foot centers with 18-inch concrete floor under.

Truck Wheel Pits. — The truck wheel pit is usually built at right angles to one of the engine pits in convenient location to remove the truck wheels, and is 4 feet 2 inches wide, 3 feet 6 inches deep, and 19 feet long, with rails 2 foot 9 inch centers supported on 6-inch flatted cedar ties, 3-foot centers with 12-inch concrete floor under.

Floor. — Concrete, brick, cinder, or wood is used. Probably a cinder floor is to be recommended for the first year or two, so that the ground may be compacted before a brick or cement one is placed. A wood floor made of old bridge timbers laid close makes an excellent floor for this class of building. A cinder floor is figured in the estimates.

Drainage. — Ten-inch or 12-inch glazed tile pipe connecting each pit at the sump hole graded to drain to manhole located convenient to suit local conditions and possible future extension.

Smoke Jacks.

The only desirable opening in an engine-house roof is that required for the smoke jack. Skylights rob the house of a good deal of heat, and very soon get blackened up.

Ventilators also, unless operated by mechanical suction or fan, are of little use.

The smoke emitted from engines, when mixed with steam, forms sulphuric acid that destroys all exposed metal. All material, therefore, for openings of any kind should be such as will not readily be affected by smoke fumes.

Smoke jacks especially should be of fire and smoke proof material, constructed so as to avoid condensation and dripping down on engines; in addition the smoke jack should form a good natural draft to assist engines in firing up, and also provide for the escape of smoke that very often fills the house when engines are entering or leaving the premises. The latter trouble is taken care of by using a combination smoke jack and ventilator.

Smoke jacks are made principally of wood, cast iron, cast iron and aluminum, asbestos, tile, and various other materials, and the three essential parts common to most consist of a hood, either stationary or swinging, that covers or engages the engine smoke pipe when in place; the ventilator portion above the roof, either separate from the smoke jack or combined with it; and the supporting mechanism attached to the roof, holding the jack in place, the safety guy or supporting cables of which are usually aluminum or copper.

The Gutelius patented smoke jack, made of asbestos and used as a standard on the Canadian Pacific Railway and other roads, has been figured in the estimates given, and consists of a combination smoke jack and ventilator, made of $\frac{1}{4}$ inch thick asbestos, set up with asbestos angles and put together with copper or brass bolts and screws.

The ventilator is 3 feet 6 inches square, 14 feet high on wood posts, protected by the asbestos plates on the outside and

asbestos angles inside, and guyed four ways to the roof with heavy wire. A damper inside is arranged if desired to prevent the heat escaping from the house when the jack is not in use.

The smoke hood under the ventilator is 3 feet 6 inches wide by 8 feet long, flared on ends and sides and hung on rigid supports, arranged so as to be adjustable in height, and provided with safety guy wires of copper. The smoke jack portion extends into the ventilator 3 or 4 feet, leaving a space all around the jack at the roof for the escape of smoke that may get outside of the jack. The smoke hood is 8 feet long to allow the hostler some latitude in spotting the engine.

Electric Wiring and Lights.

Probably the best method of wiring engine houses is to enclose all wires in conduit pipe and sealed boxes, running the mains and branches on the roof, an improved type of which is the "Ravelin" patented system. By this method all wiring and joints are protected from smoke and gas fumes, and the work of wiring is simplified, and as all parts are accessible, repairs can be made easily.

Usually three incandescent 16-candlepower drop lights are placed between each stall, with a plug receptacle connection on each post for portable hand light. The lamps are protected by wire screens over the lights.

Switches are placed on the back or front walls for each stall or series of stalls.

Outside, arc lights are generally used, strung on poles in convenient position. The number vary with the size of the house and the amount of light desired.

Approximate cost.—The cost of complete installation varies from \$40 to \$60 per stall.

Steam Air and Water Pipes. (Fig. 59a.)

One of the most important features about an engine house is the installation of the steam, air, and water pipes.

The steam is required for heating purposes and engine supply, the air for engine and shop supply, and the water for washing out purposes and fire service.

For the ordinary run of engine houses up to 22 stalls the following sizes are commonly used:

Live steam main 3 inches diameter, branches $1\frac{1}{2}$ inches diameter.

Air pipe main $1\frac{1}{2}$ inches diameter, branches $1\frac{1}{4}$ inches diameter.

Water service main 3 inches diameter, branches 2 inches diameter.

The branch pipes where connections are desired are arranged so as to be attached to the inside posts, and terminate about 5 feet from the floor. The steam pipe is equipped with a valve and air-brake coupling, the coupling being used for hose connection to convey live steam to engine boilers when necessary.

The air pipe is fitted with a Westinghouse air brake and coupling.

The water pipe is equipped with gate valve and drip cock for fire purposes, also a globe valve and hose coupling for engine boiler service; in addition a short length of pipe extends above the fire valve, with elbow, to which are attached 50 feet of rubber-lined hose and 18-inch fire hose nozzle; the hose and nozzle are supported on a stand with movable brackets secured to the posts and encased in wood frame with glass front.

A valve is placed on each branch pipe near the main so that any branch supply can be cut off for repairs without interfering with the rest of the house.

Owing to smoke fumes corroding the iron and the annoyance from dripping it is considered the best practice to place the pipes in underground ducts instead of stringing them overhead inside the house.

The ducts are arranged so as to be easily accessible for repair purposes and valve service, and are usually built of wood or concrete.

The wood duct, though cheap in first cost, is high in maintenance. On account of being subjected to the moisture from the ground on the outside, and excessive heat inside, it soon rots out, and has to be renewed every few years.

To eliminate the maintenance charges entirely, it is necessary to build the ducts of concrete or masonry, or such material as will be permanent; and to be successful it is also necessary that its cost will compare favorably with the price of wood.

The "Thurber" patented system of rib concrete ducts is said to accomplish this result, and the method of installation is as follows:

The main ducts carry the steam, air, water, and heating pipes, run between and connect each engine pit, either at the front or back of the house, making a continuous passage throughout, so that no breaking or cutting of walls for the passage of pipes is necessary; they are made 2 feet 9 inches wide and 2 feet 9 inches deep.

The ducts carrying the branch steam, air, and water pipes connect with the main duct between alternate pits, and extend back to the end post so as to serve two pits, the pipes being carried up the post face. The branch ducts are 1 foot 6 inches wide and 1 foot 6 inches deep.

The method of building the ducts consists in placing iron tee section ribs at varying intervals, not exceeding 3 feet, and setting up concrete slabs between; the slabs fit into the bottom pockets and bear against the iron sides of the ribs, and are held by bolts or rods at the top, the rods being used to hang the pipes inside the ducts. The floor can be made in slabs or built in concrete in the usual way. All slabs are laid in cement mortar.

The approximate cost of steam, air, and water pipes installed complete, not including the ducts, averages from \$55 to \$80 per stall.

Heating Engine Houses.

In the heating of roundhouses there are two methods in vogue, the hot air system and the direct steam vacuum method.

Hot Air Heating. — The heating apparatus when possible is placed about the center of distribution either in the engine or boiler house or in a separate annex, and consists of an engine, fan, and heater, set up and anchored on concrete or wood foundation.

The heater is made up of a series of coiled steam pipes enclosed by a sheet steel jacket, to which is attached a steel plate fan, usually driven by a vertical or horizontal steam engine.

The fan draws the air over the steam coils and forces the hot air through pipes or ducts to any part of the house desired.

On account of smoke fumes corroding any iron work that is not well protected, the air ducts are usually placed underground. The main duct is built of reinforced concrete, and the branches are usually tile pipe, though wood is often used on account of cheap first cost.

Usually the main duct runs around the back of the house, the inside face of foundation wall serving as one side. It is necessary that all inside surfaces should be as smooth as possible, without projections of any kind inside the duct. Branches are taken off the main with long radius bends and run down between pits with offsets to the engine pits, and risers at points where it is desired to admit hot air to heat the balance of the house, the outlets being controlled by dampers.

The ducts absorb a portion of the heat and are also subject to dampness from condensation. The main point is to provide means for keeping them dry. This is done by grading the ducts so as to drain to the air outlets, and placing covers in the main duct that can be opened to let out the dampness at favorable times.

Capacity and approximate cost. — The capacity of the heating apparatus depends upon the size of the house. In any event it is always necessary under ordinary conditions to figure the units large enough so as to provide for a reasonable future house extension.

For the ordinary run of engine houses the supply of hot air per minute varies from 2000 to 3000 cubic feet per stall at a fan speed of 200 revolutions per minute.

Figuring 2250 cubic feet of air per minute, a 20-stall engine house would require the following:

Steel plate fan 8 feet in diameter by 4 feet wide. Theoretical capacity, 45,000 cubic feet of air per minute at 200 revolutions.

Side crank steam engine 8" \times 12".

Heating coils, 6700 lineal feet of 1-inch pipe capacity.

Approximate cost of the above installed, with concrete foundation walls and timber floor for the fan and heater, varies from \$2800 to \$3400, or on an average \$150 per stall.

The cost of the main ducts, branches, risers, dampers, etc., in place averages from \$100 to \$180 per stall, or the cost of the complete installation \$250 to \$350 per stall.

The sizes of the mains and branches have to be figured out for the volume of air carried, and are usually given by the manufacturers of the heating outfit. No boilers, or steam main connections from the same, are included in the estimate.

A feed water heater and pump with valves and connections arranged to receive the drip of the heating system for boiler feed is often added, also a vacuum pump in connection with the hot air heater to relieve pipes of air, etc., and give good steam circulation.

The cost of a 100 horsepower heater with feed and vacuum pump, including valves and connections set up complete for the above heating apparatus, varies from \$500 to \$750.

The heater is generally arranged to condense the exhaust from the fan or other engines for boiler feed, and when omitted, steam traps are provided for removing the water of condensation to the drain.

In exceptionally cold weather, the air is taken from the engine house and reheated, openings being provided in the air chamber so that this can be accomplished. It is not an ideal method, but under exceptional conditions is often necessary.

Steam Heating. — The ordinary method is a low pressure direct steam heating system, adapted to use and utilize all exhaust steam available from the engine and boiler house, with such additional live steam as may be necessary from boiler during severe weather.

From the exhaust header the main steam supply is run around either the front or back of the house, usually in the underground

ducts carrying the air and water pipes, with branches to the pit and wall coils, including a return main to which all coils are connected.

The steam main reduces in size as it goes along proportionately as the amount of radiation is decreased, and the size of the return pipe is increased proportionately as the coils are added to it. To relieve heating coils of water of condensation and air, the return pipe is connected to a vacuum pump located in pit near the boiler, the water of condensation being discharged into a feed water heater, and from the heater to the boiler by a feed pump. The exhaust header is connected into heater full size of header, with relief pipe from heater to roof fitted with a back pressure valve.

Valves are applied in steam main or mains near exhaust header, between vacuum pump and heater, steam supply from boiler to vacuum, and boiler feed pumps.

Heating Surface and Equipment Required. — For ordinary roundhouses the amount of heating surface usually installed varies from 1 to 1½ square feet per 100 cubic feet of enclosed space; probably 1¼ square feet is a fair average.

For one stall having a capacity of 34,000 cubic feet the heating surface would be $\frac{34000}{100} \times 1\frac{1}{4} = 425$ square feet, or 680 lineal feet of 2-inch pipe per stall.

The best distribution is to put four pipes on each side of the engine pit and the balance as coil radiators on the roundhouse walls.

Sometimes five or six rows of pipe are placed on the engine pit walls, but this method is not recommended, as it will usually be found that so much pipe will impede circulation, and as a result the bottom pipes are generally cold.

The pipes are supported by cast or bent steel pipe hangers about 6 feet apart. Usually wood plugs or strips are built into the wall to which the pipe supports are attached by lag screws, the screws serving in the case of the bent steel hangers as supports on which the pipes rest.

For a 20-stall engine house the steam main would be 5 inches for the first ten pits, 4 inches for the next six, and 3 inches for the balance. They are hung from strap hangers supported by rods passing through the ducts about 7-foot centers, or on floor rollers with

expansion bends. The return would be 2 inches for the last four pits, $2\frac{1}{2}$ inches for the next six, and 3 inches for the balance.

The heater not less than 100 horsepower, and made sufficiently strong to carry 10 pounds of steam pressure. The vacuum pump $3\frac{1}{4}'' \times 5\frac{1}{2}'' \times 4''$, all brass lined, and feed pump $4\frac{1}{2}'' \times 2\frac{3}{4}'' \times 4''$ duplex.

Approximate cost. — The cost for complete installation varies from \$225 to \$300 per stall without ducts. Only a portion of the cost of ducts would be chargeable to the heating, as the same ducts would be used to run the live steam, air, and water pipes. No boilers are included in the above estimates. See under "Boiler Houses" for cost of boilers, etc.

Washout System. — By using a series of hot water tanks suitably connected with pipes, valves, pumps, etc., the steam and water can be taken from locomotives and stored in tanks to be reused for washing-out purposes and refilling when desired.

By this method a large saving of time is effected in washing out and refilling locomotive boilers, and as the water is hot, the work is done without danger from unequal expansion to the tubes, stay bolts, or fire box, and in addition 50 per cent of the water is saved and reused, and it is possible to take the water from a boiler and refill with a fresh supply in 30 minutes without removing the fire. To blow off, wash the boiler, and refill it with a fresh supply, and obtain 100 pounds steam requires about two hours. The old method of blowing off and letting the water waste to the drain requires from 8 to 10 hours to wash out, refill, and get 100 pounds steam.

The system consists of one or a series of storage tanks, with blow off, hot water, wash out, and filling, pipe lines, including live steam piping to the tanks, also valves and connections; where a series of tanks are used for washing out, refilling, and superheating, pumps are required to maintain pressure at the hose nozzles for filling purposes.

Approximate cost. — Usually the piping is furnished to a few pits only when for washing out purposes, and to each pit if refilling and washout system is installed. The cost varies from \$6000 to \$25,000, depending upon the capacity and requirements of the plant.

APPROXIMATE ESTIMATE FOR ONE STALL 85 FEET LONG ENGINE HOUSE
MILL CONSTRUCTION. (Figs. 58, 58a.)

Quantities.	Material.	Labor.	Total unit.	Cost.
Excavation 14 yards.....			\$.50	\$ 7.00
Concrete, 26 yards.....	\$3.50	\$4.50	8.00	208.00
Steel, 9000 pounds.....	.02½	.02½	.04½	405.00
Encased concrete, 8 yards.....	4.00	8.00	12.00	96.00
7500 feet board measure, per thousand ...	22.00	18.00	40.00	300.00
144 square feet back window.....	.40	.20	.60	86.40
40 linear feet eaves.....	.25	.15	.40	16.00
208 square feet door front.....	.30	.20	.50	104.00
80 square feet window front.....	.40	.20	.60	48.00
17 squares roofing, per square (100 square feet).....	2.00	2.00	4.00	68.00
500 feet board measure squared timber, per thousand.....	18.00	17.00	35.00	17.50
4 cedar ties.....	.40	.10	.50	2.00
Combined asbestos and ventilator smoke jack erected.....	100.00	25.00	125.00
Reinforced hot air or pipe ducts [27 feet], 7 yards.....	4.00	6.00	10.00	70.00
12 yards excavation50	6.00
Engine Pit.				
87 yards excavation.....			\$43.50
40 yards concrete.....	\$3.50	\$4.50	\$8.00	320.00
2500 feet board measure 6-inch plank, per thousand.....	18.00	17.00	35.00	87.50
5 yards floor	4.00	6.00	10.00	50.00
14 feet 12-inch tile.....			.50	7.00
Cast iron gratings.....	2.75	.75	3.50
Heating.....				250.00
Steam, air, and water				55.00
Electric wiring and lights.....				55.00
Floor 12-inch cinders 56 yards at 50 cts.....				28.00
Door posts.....				5.00
Proportion of end or fire walls drop and wheel pit per bay.....				150.00
				\$2638.00
Engineering and contingencies 10%.....				262.00
Total.....				\$2900.00

Fig. 60 illustrates a cross section of an engine house erected by the L. S. & M. S. R. at Elkhart, Indiana.

This house is a combination of flat and sloped roof construction, which is to be commended, as the engine fumes ascend into the high portion, and serves to keep the lower portion more free from smoke. The smoke jacks are 12 feet long, which allows the hostler some latitude in spotting the engines.

The cost of this house, which is 90 feet long, would average from \$2200 to \$3000 per stall complete.

Boiler Houses.

The boiler house is usually built behind the engine house, as an annex, principally to supply steam, air, and water to the engine house proper, and incidentally to supply heating for other buildings and cars in the yard if necessary.

The building consists of machine, engine, and boiler rooms, with locomotive foreman's offices, registry room, and lavatory on one side of the machine room, having a small gallery for light stores over. The boiler room is made sufficiently large to hold two or three batteries of boilers, with a coal bin on one side which is filled from cars through the openings above.

Approximate cost. (Fig. 61.)—The average cost of boiler houses for the building only, ranges from \$1.75 to \$2.50 per square foot; for the one illustrated the cost would be \$6000 to \$7000.

For boilers and equipment 100 to 150 per cent extra.

Two 100-horsepower boilers erected complete \$3500 to \$4000.

Engine room equipment \$3000 to \$5000.

Construction.—Masonry foundation walls to five feet below ground, face walls common brick, stone, or concrete, with arches over doors and windows. Roof 8"×14" beams at 8-foot centers, covered with 3-inch plank, and tar and gravel on top. Office inside finished with hardwood floor, ordinary trim, and plastered walls and ceilings.

Machine room: hardwood floor, walls and woodwork white-washed; boiler room: brick floor, with wood plank over coal bin, walls and woodwork whitewashed.

The ordinary locomotive type of boiler is generally used in units of 100 horsepower, with mechanical draft or large chimney, the boiler room being made large enough to hold an additional boiler in case of future extension.

The machine room equipment generally consists of an engine and air compressor and a small lathe, planer and saw, with benches fitted up for convenient use.



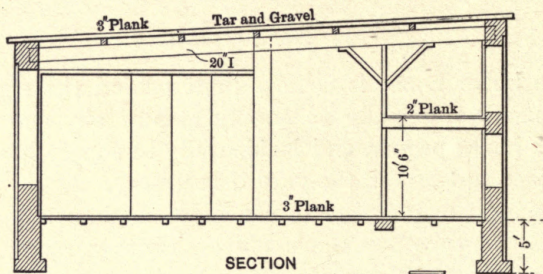

SECTION

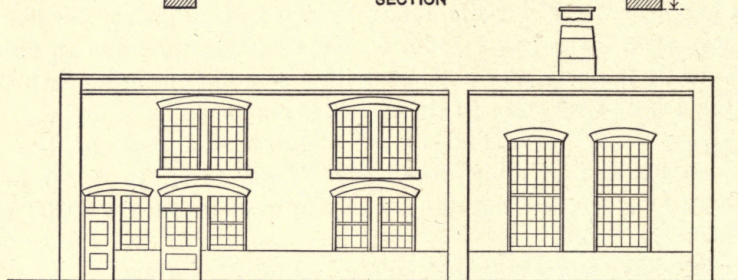

ELEVATION

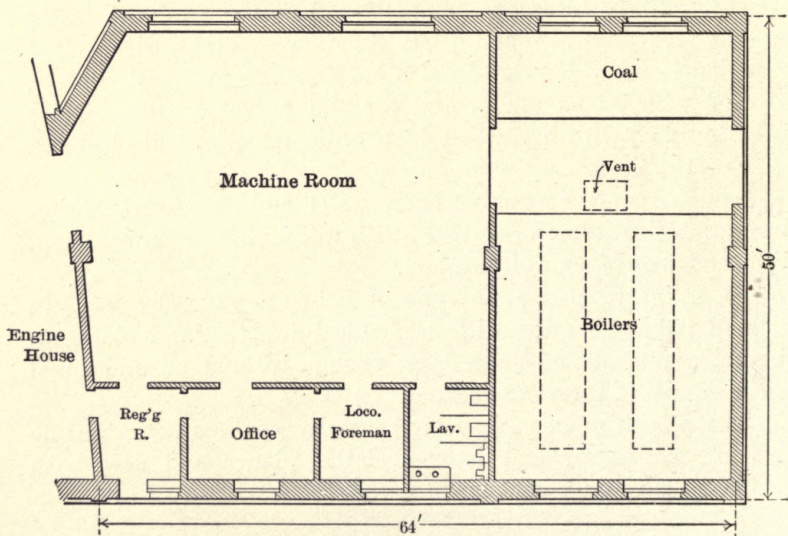

PLAN

Fig. 61. Boiler House.

Storehouses.

At divisional, terminal, and other points store houses are necessary to receive and store supplies for engine, car, and general service, for repair and operating purposes.

The house is usually a frame structure on masonry, cedar sill, or post foundation, divided up with shelving and racks to hold the miscellaneous articles usually kept in stock, with an office in one corner for the storekeeper; to this may be added a counter if desired.

Sometimes the store and oil house are combined, or the oil house is placed in close proximity to the storehouse so that both can be looked after by the storekeeper.

APPROXIMATE COST OF STOREHOUSES COMPLETE, INCLUDING PLATFORMS, ETC. (Fig. 62.)

Size.	Wood foundation and floor.	Concrete foundation and concrete floor.
30'×30'×13' high	\$ 900.00 to \$1200.00	\$1500.00 to \$1800.00
45'×30'×13' high	1300.00 to 1500.00	2100.00 to 2500.00
60'×30'×13' high	1800.00 to 2100.00	2800.00 to 3300.00

Construction. — Fig. 62 illustrates a small storehouse 30' × 30' with platform. The house can be extended by adding 15-foot bays.

Concrete foundations taken below frost, walls filled between with sand or good ballast well puddled and finished on top with concrete or wood floor. Framing consists of 2"×6" studs 2-foot centers, with 1-inch rough boards and siding, and building paper between on the outside and sheathed on the inside. The roof is made of 4"×12" rafters at 7 foot 6 inch centers, covered with 3-inch plank and tar and gravel. Shelvings and racks are provided to suit the class of goods kept in stock.

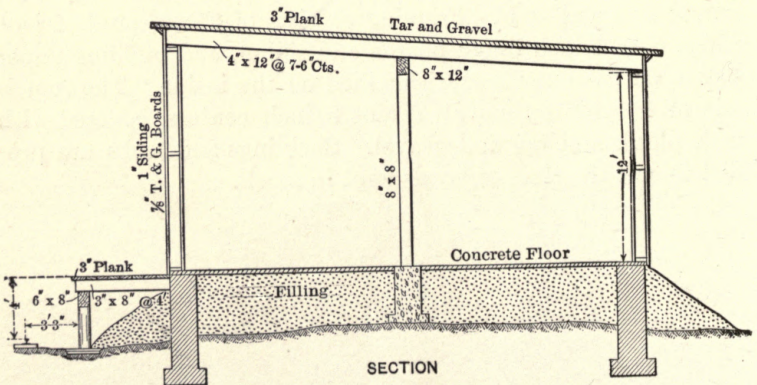
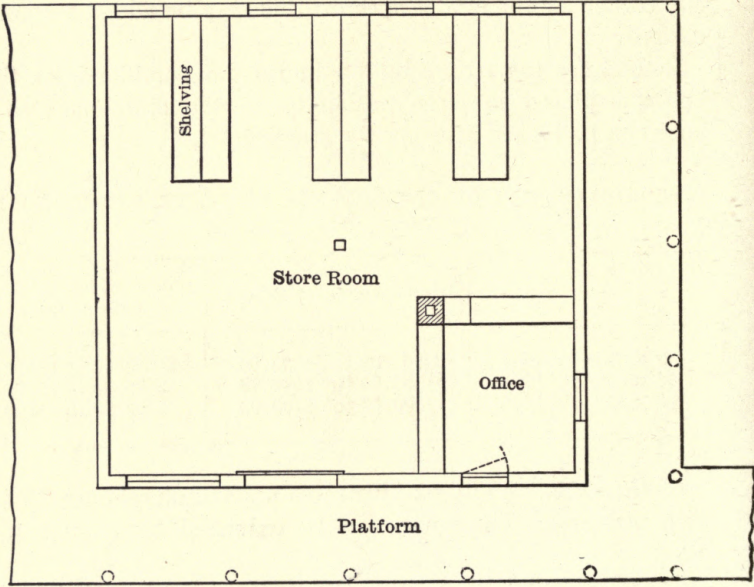
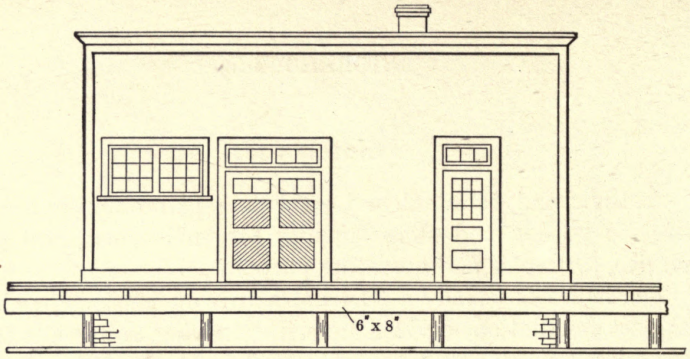

Fig. 62. Storehouse.

Approximate estimate: (Fig. 62.)

Quantities.	Material.	Labor.	Total unit.	Cost.
50 cubic yards excavation.....			\$.50	\$ 25.00
54 cubic yards masonry.....	\$2.00	\$3.00	5.00	270.00
14,500 feet board measure lumber, per thousand.....	18.00	17.00	35.00	507.50
Doors and windows.....	42.50	20.00		62.50
Hardware.....	20.00	15.00		35.00
Roofing.....	24.00	26.00		50.00
900 square feet concrete floor and filling.....	.08	.12	.20	180.00
Brick chimney.....	8.00	12.00		20.00
Painting and glazing.....	20.00	25.00		45.00
Shelving.....	100.00	70.00		170.00
				<hr/>
Supervision and contingencies.....				\$1,364.00
				136.00
				<hr/>
900 square feet platform at 15 cts.....				\$1,500.00
				135.00
				<hr/>
Total.....				\$1,635.00

\$1.65 per square foot with masonry foundation and concrete floor.

\$1.50 per square foot with masonry foundation and wood floor.

\$1.25 per square foot with wood foundation and wood floor.

Oil Houses.

Oil houses are necessary on railroads to store and handle the various oils required for engine, car, and shop service.

The most common arrangement consists of a frame or masonry shed with basement and platform, located alongside a track in convenient proximity to the various departments to be served.

Usually steel tanks are provided for storing the oil, varying in capacity from 500 to 2000 gallons or more; they are set up on concrete supports in the basement, so that they can be easily examined and cleaned.

When the supply is brought by barrels, they are dumped over fillers inside the house or outside on the platform if desired; when filled from car service tanks, the pipes are extended under the platform and provided with stop cocks and hose connections as per Fig. 63.

The floor over the basement is usually heavy plank not less than 3 inches thick, or reinforced concrete. A trap door and small ship ladder are necessary to gain access to the basement, the trap door and frame being made fireproof. No other openings are provided, electric light being used when desired for inspection purposes.

The tanks are generally ventilated by a pipe connecting each tank, with a main riser taken above the roof, to allow escape of air and gases.

The floor above the basement is used for the distribution of oil to employees; each tank is connected to a hand or power pump; the pumps are grouped together and set up conveniently in one corner of the house with oil stands, trays, and drip pans, and a counter with waste bins and can racks is placed where most convenient.

APPROXIMATE COST OF OIL HOUSES COMPLETE. (Fig. 63.)

Size.	Concrete foundation and floor, wood platform.
30'×20'×12' high	\$1500.00 to \$1900.00
45'×20'×12' high	2500.00 to 2900.00
60'×20'×12' high	3000.00 to 3900.00

Construction. — The chief points to be considered in the construction are to eliminate the risk of fire, to provide ample storage

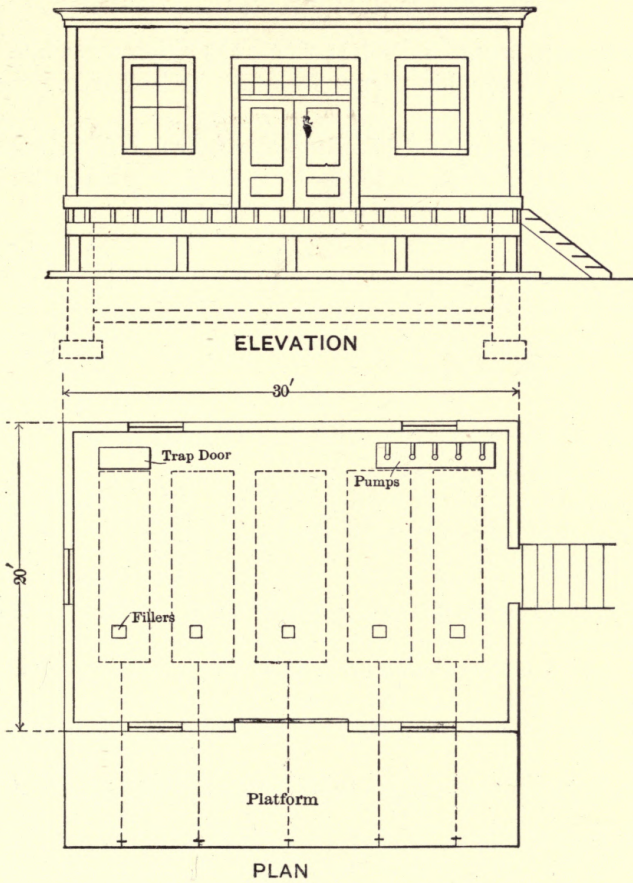

SECTION

Fig. 63. Oil House.

and convenient means for filling the tanks either from barrels or oil cars, and to provide proper facilities for handling, pumping, and distribution.

Fig. 63 illustrates a 30' × 30' oil house with steel tanks in basement.

The foundation walls up to platform level, also basement floor, are of concrete; the oil house floor may be of reinforced concrete or heavy plank. The house frame is 2" × 6" studs at 2-foot centers with rough boarding and shiplap with building paper between on the outside, and 1-inch sheathing on the inside. The roof is 2" × 8" joists at 2-foot centers covered with 1-inch T. and G. boards and finished with tar and gravel.

The platform on the track side is supported on 8-inch diameter cedar posts on mud sills, with 2" × 10" joists at 24-inch centers covered with 3-inch plank.

The tanks are made of steel boiler plate with pipe connections and hand hole with valve for cleaning purposes, and have the following capacity:

Four feet 6 inches diameter, $\frac{1}{4}$ inch thick metal, 12 feet long, 1200 gallons.

Four feet 3 inches diameter, $\frac{1}{4}$ inch thick metal, 12 feet long, 1000 gallons.

Three feet 3 inches diameter, $\frac{3}{8}$ inch thick metal, 12 feet long, 600 gallons.

Three feet diameter, $\frac{3}{8}$ inch thick metal, 12 feet long, 500 gallons.

Approximate estimate of cost: (Fig. 63.)

Quantities.	Material.	Labor.	Total unit.	Cost.
68 cubic yards excavation.....			\$.50	\$ 34.00
53 cubic yards masonry.....	\$ 2.50	\$ 3.50	6.00	318.00
23 cubic yards concrete.....	3.00	3.50	6.50	149.00
7000 feet board measure lumber, per thousand	18.00	17.00	35.00	245.00
Doors and windows.....	50.00	35.00	85.00
5 squares roofing, per square (100 square feet)	2.50	2.50	5.00	25.00
Hardware and reinforcement.....	75.00	47.00	122.00
Painting and glazing.....	25.00	30.00	55.00
5 tanks, capacity 4100 gallons.....	280.00	296.00	576.00
Pumps, piping, connections, and fittings ...	100.00	63.00	163.00
Steam coils.....	16.00	12.00	28.00
				\$1,800.00
Supervision and contingencies.....				180.00
Total.....				\$1,980.00

or about \$3 per square foot or 16½ cts. per cubic foot.

Ice Houses.

Ice houses are generally framed structures built by the railway company to store ice at divisional, terminal, and other points convenient for storage and supply. The houses are stocked in winter, and the ice used for drinking purposes, etc., in office, car, freight, and general service.

For office and car service the ice is washed and broken up in the ice house, and trucked to the cars, etc. For refrigerator freight service a siding is generally placed close to the ice house, with an elevated platform running alongside, from which the ice is handled from house to car by trucks.

Ice-handling machinery for storing and handling blocks of ice either into or out of storage consists, if the quantity is small, of adjustable tackle hung from beams projecting over the doors, the doors being arranged in tiers to facilitate the handling of ice at different levels; when large quantities are handled, elevating and lowering machines on the endless chain, pneumatic, or brake principle are used which automatically dump the blocks at any level desired.

In estimating the capacity of ice houses, the height of storage is usually reckoned to the eaves, and a ton of ice will occupy from 40 to 45 cubic feet of space.

Cost. — Ordinary frame structures, cedar sill foundation, insulated walls, two air spaces and three boards, insulated partitions and roof with louver ventilators, and 1-inch rough hemlock board floor, on a cinder bed as per Fig. 64, will cost approximately \$3.00 to \$4.50 per ton capacity, or 7 to 10 cents per cubic foot.

APPROXIMATE COST OF VARIOUS SIZES OF ICE HOUSES.

	Wood founda- tions.	Masonry Founda- tions.
250-ton ice house 24 feet wide by 36 feet long by 18 feet high to eaves.....	\$ 950	\$ 1,300
500-ton ice house 24 feet wide by 72 feet long by 18 feet high to eaves.....	1,850	2,500
1000-ton ice house 30 feet wide by 84 feet long by 20 feet high to eaves.....	3,350	4,000
2000-ton ice house 30 feet wide by 168 feet long by 20 feet high to eaves.....	6,650	7,800
3000-ton ice house 30 feet wide by 252 feet long by 20 feet high to eaves.....	9,950	11,500

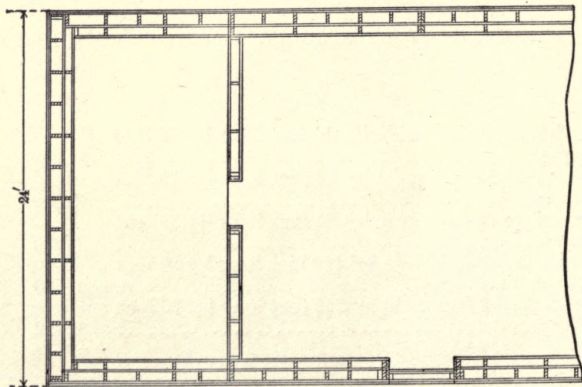
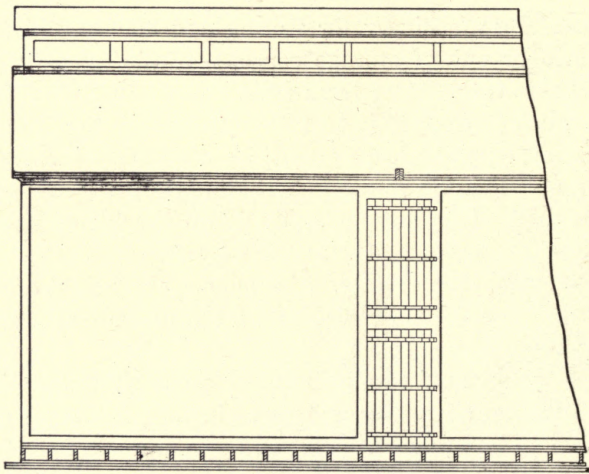
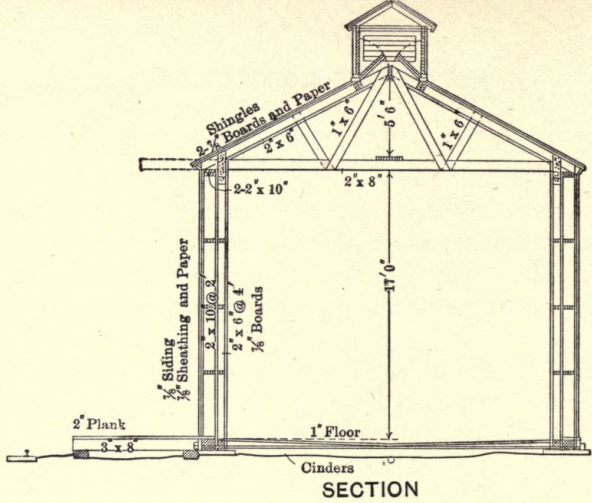

APPROXIMATE ESTIMATE FOR A 250-TON ICE HOUSE. (Fig. 64.)

Quantities.	Material.	Labor.	Total unit.	Cost.
20,000 feet board measure lumber, per thousand	\$18.00	\$17.00	\$35.00	\$ 700.00
Doors.....	25.00	10.00	35.00
Hardware.....	25.00	15.00	40.00
Paint.....	34.00	40.00	74.00
Cinders and drain.....	18.00
				\$ 867.00
Supervision and contingencies.....				83.00
				\$ 950.00
If masonry foundation, add.....				350.00
Total.....				\$1300.00

Construction. — To avoid shrinkage as much as possible, stone or concrete foundations should be used for the outer walls; ordinary wood sill foundation is not sufficient to prevent heat penetrating through the outside ground to the floor in summer.

The outer walls and roof should be insulated with at least three coverings of board and two air spaces, and a vent should extend the full length of roof.

The house should be divided up into a number of compartments, the cross partitions serving to tie in the main walls instead of iron rods; it also serves to lessen the exposure of ice to warm air when ice is going out; it divides the house into so many units, and one unit only is exposed when handling.

The floor should slope slightly both ways to the center of the house and be well drained, the drain having a water seal and vent when possible.

Cutting, Storing, and Handling. — No doubt the method of cutting, storing, and handling the ice has a great deal to do with obtaining results. Outer doors should be used only when filling the house, and inner doors for removing; working always to one main outlet rather than to a series of outlets. All ice should have snow caps planed off before storing, and the blocks cut to a size easily handled; 100 pounds or thereabout, 10 to 14 inches thick, is recommended.

When storing, a space should be left all around each block, so that it may not be necessary to hack and break the ice too much when removing. For quick and easy handling ice machines should be used rather than slides or block tackle, to avoid waste and to deliver the ice in good condition.

Artificial Ice Making.

In many localities it may be cheaper to erect a mechanical ice-making plant than to store ice, and the following is an approximate estimate of the installation and the cost of operating a 20-ton capacity plant by steam and electric power.

When electric power can be obtained at a cheap rate, the cost of a boiler house is saved, and the inconvenience of handling coal, etc., is done away with, or when the house can be placed in some position in the yard where steam is available the same remarks would apply.

Steam Plant. — Capacity 20 tons of ice per day per 24 hours, allowing for 300 working days = 6000 tons per year.

Approximate cost of installation.

Boiler, machine shop, and ice house.....	\$ 6,250.00
Boiler and machinery foundations.....	800.00
Water pipes and connections.....	500.00
Boiler, feed water pump, injector, steam engine, steam pipes and connections, ammonia compressor, condenser, ice tank with cans, coils, ice lift, etc., including insulation and all connections, erected complete.....	20,500.00
Distilling plant.....	2,500.00
	<hr/>
	\$30,550.00
Supervision and contingencies 10%.....	3,050.00
	<hr/>
	\$33,600.00

Approximate cost of operating steam plant, figuring 300 days per year.

Interest on first cost \$33,600 at 6%		\$2,016.00
2 engineers at \$2.50.....	\$ 5.00	
1 helper at \$1.50.....	1.50	
2 ice men at \$2.....	4.00	
Oil and waste.....	1.00	
3 tons of coal at \$3.....	9.00	
Depreciation, repairs, and incidentals.....	3.50	
	<hr/>	
	\$24.00 × 300	7,200.00
		<hr/>
Total.....		\$9,216.00

or \$1.54 per ton.

Electric Drive. — Capacity 20 tons per day per 24 hours, allowing for 300 working days = 6000 tons per year.

Approximate cost of installation.

Machine shop and ice house.....	\$ 4,000.00
Foundations.....	500.00
Water pipes and connections.....	500.00
Motor, compressor, condenser, ice tank with cans, coils, ice lift, etc., including insulation and all connections, erected complete.....	19,533.00
	<u>\$24,533.00</u>
Distilling apparatus, if steam can be furnished.....	2,500.00
	<u>\$27,033.00</u>
Supervision and contingencies 10%.....	2,767.00
	<u>\$29,800.00</u>

Approximate cost of operating electric plant.

\$29,800 at 6%.....	\$1,788.00
Electric power, 60 H.P. at \$40 per year.....	2,400.00
2 engineers at \$2.50.....	\$ 5.00
2 ice men at \$2.....	4.00
Oil and waste.....	1.00
Depreciation, repairs, and incidentals.....	4.00
	<u>\$14.00 × 300 days 4,200.00</u>
Total.....	<u>\$8,388.00</u>

or \$1.40 per ton.

Cold Storage.

For hotel, dining car, and restaurant service it is necessary to have good storage and ample facilities for keeping eatables in first-class condition, as the supplies are usually bought in large quantities; this necessitates either an ice or mechanical refrigeration plant. For dining car service the building is generally located at one end of the sleeping and dining car stores, and in the basement of hotels or restaurants.

Comparing natural ice and mechanical refrigeration, the latter is by far the best means of keeping dining supplies; with natural ice the cooling process is limited, there is also dampness and poor ventilation to contend with; ice leaves a residue liable to foul unless the storage box is cleaned out frequently.

With the mechanical cold air process the proper temperature for keeping supplies in the best condition can be attained, and the temperature can be varied for any class of goods; the air is purified and fresh at all times.

Cold Air Refrigeration. (Fig. 65.) — The walls and partitions are insulated similar to ice houses, and divided into compartments for storing the various classes of goods.

The mechanical plant is placed at one end of the building, and consists of a steam engine coupled to a double-acting ammonia compressor, an ammonia condenser and receiver, with all necessary ammonia gauges and gauge boards; connection pipes and fittings, including an air cooler, consisting of an iron tank with refrigerator coils, brine pump, air fan, and sundry connections.

The cooler is placed next to the cold storage room, and the wall between it and the engine room must be insulated similar to outer walls.

The following is a comparative estimate of installing and operating a cold air plant and natural ice refrigeration plant.

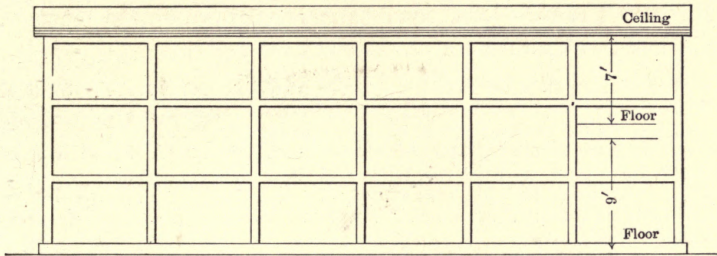

ELEVATION

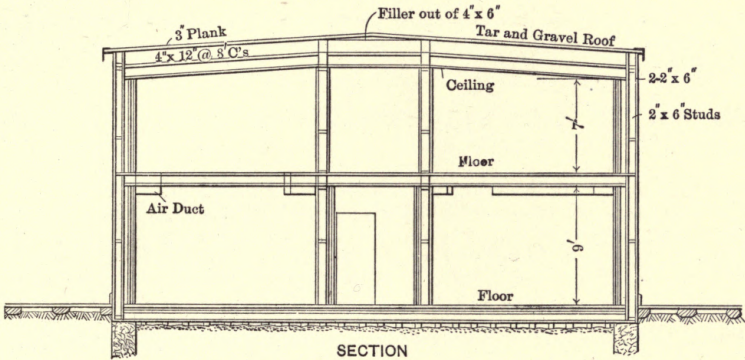

SECTION

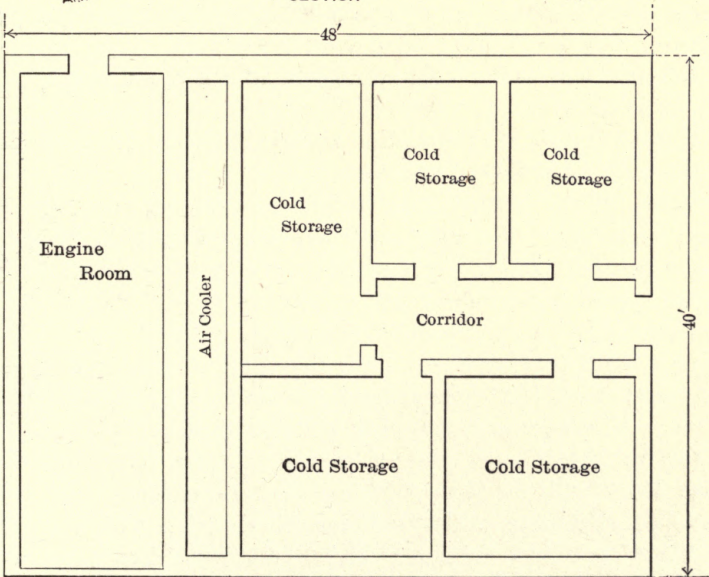

PLAN

Fig. 65. Cold Storage House.

Cold Air Plant. — Six tons capacity, approximate cost of installation and operation.

Cold storage house 40'×48'×24' high, \$3600 at 6%	\$216.00
Cost of 6-ton ice plant, \$3200 at 6% per annum.....	192.00
Foundations for ice plant, \$200 at 6% per annum	12.00
10 horsepower per annum at \$40 per horsepower	400.00
Maintenance, repairs, and depreciation	42.00
Labor, one man at \$2 per day (see note).....	730.00
Ammonia per annum	30.00
Water rates	35.00
	\$1,657.00

NOTE. — One man can run an ordinary 35 horsepower plant and also assist in the shop or stores at other work. Less than 30% of his time is taken up with the cold storage plant.

Natural Ice Plant. — Approximate cost of installation and operation.

Increased height of building for ice storage with air ducts, drainage, lifts, and insulation, \$4800 at 6% per annum.....	\$ 288.00
3 tons of ice per day at \$2 per ton.....	2190.00
Labor, one man at \$1.50 per day.....	548.00
	\$3,026.00

From the above it will be noted that the cold air plant, besides keeping the supplies in better condition, is a good deal less costly than buying ice at the price quoted.

Construction. — For cold storage buildings the construction is about as follows:

Rubble or concrete foundation walls taken below frost, 24 inches thick, with 12-inch footing course.

Outer Walls, Frame Buildings. — Beginning on the outer face, two layers of 1-inch matched sheathing, with insulating paper between, 2"×6" studs at 16-inch centers, two layers 1-inch sheathing with insulating paper between, 2"×4" studs 16-inch centers, with 1-inch matched sheathing, 2 by 2 studs 16-inch centers, with two layers of 1-inch sheathing and insulating paper between; with this arrangement the walls are about 20 inches thick. All spaces are filled with mill shavings.

Ground Floor. — A bed of gravel at least 12 inches thick, with 3"×3" sills on top, at 18-inch centers, covered with 1-inch matched sheathing, and 1"×2" scantling on top, and two layers of 2"×4" matched flooring over, laid flat with insulating paper between. All spaces are filled with mill shavings.

Inner Walls. — Between cold storage rooms: 2"×6" studs at 18-inch centers, with two layers of 1-inch matched sheathing on either side, and insulating paper between boards, all spaces filled with mill shavings.

Between cold storage rooms and corridors: 2"×8" studs at 18-inch centers, with two layers of 1-inch matched sheathing and insulating paper between on the inside, and 1-inch matched sheathing, and 1"×2" scantling 18-inch centers covered with two layers of matched sheathing, with insulating between, on the corridor side.

Ceiling. — Two-inch by 8-inch studs at 18-inch centers, with two layers of 1-inch matched sheathing on each side, with insulating paper between boards. Spaces filled with mill shavings.

Roof. — Two-inch by 8-inch studs, 18-inch centers, with two layers 1-inch sheathing on each side, with insulating paper between, roof joists 4"×12" at 8-foot centers, with 3-inch T. and G. boarding on top, covered with 5-ply tar and gravel roofing.

Cold Air Ducts. — Wooden air ducts are provided for exhausting the air from the various rooms to the fan and cooler, and from the cooler back into the rooms.

Insulation for the main suction ducts consists of two layers $\frac{7}{8}$ -inch T. and G. sheathing with double insulating papers between and 1"×1" battens on the outside covered with 1-inch T. and G. sheathing; other ducts consist of double boarding with insulating paper between.

The ducts are placed usually on each side of the room close to the ceiling, with hardwood slides on the bottom of the delivery ducts and on the sides of the suction ducts.

Coaling Stations.

Coaling stations are erected to supply engines quickly with coal, to reduce delay to engines and to release coal cars as soon as possible, to take care of all coal held for emergencies (at least three days' supply), and to minimize the cost of handling.

They are usually built at divisional, terminal, and other points and are principally constructed of wood, though concrete and steel are coming into extensive use for this class of structure. Generally speaking, no mechanical plant can handle coal, ashes, and sand with the same mechanism and do it efficiently; the nature of the materials is such as to render this a very difficult matter.

The structure is usually located parallel to or across the round-house tracks, convenient to the cinder pits, the arrangement depending upon the type of coaling plant adopted.

Hand Shoveling. — The coal is shoveled direct from flat-bottom cars into the locomotives, the track being elevated in some cases to facilitate shoveling; this method is probably the cheapest for very small amounts.

The cost of elevated track depends on the nature of the ground. In many cases the location may lend itself to make this a very easy and cheap method. When a trestle or fill has to be made the approximate cost would be \$250 to \$500.

Jib Crane and Buckets. — Where the demand is somewhat heavier than the above, but quick service is not essential, a platform is added and one-ton buckets used for storage, the buckets being filled when convenient and held ready for service when required. A jib crane operated by air is used to hoist and dump the buckets. This method is also cheap for a limited quantity, when air can be piped from the boiler house close by. The same remarks in connection with the elevated track for hand shoveling will apply here also, and the approximate cost would average \$750 to \$1500 or more.

When a platform is used alone the cost would average from 25 to 50 cents per square foot of platform.

Mechanical Plants. — The ordinary mechanical plants, consisting of elevated pockets fed by endless chain, belt, or buckets, are arranged to hold from 30 to 800 tons or more; the amount

of coal elevated per day depending upon the capacity required, the number of tracks to be served, and the storage necessary for emergencies.

The cost of a mechanical type of coaling plant varies according to capacity and style of plant adopted, and may range from \$20 to \$75 per ton capacity. In cases where it is necessary to weigh the coal taken by locomotives the cost is somewhat increased.

In figuring the cost of handling coal the unit considered is generally one ton of 2000 pounds.

To make a fair comparison for any type the following items should be estimated and fair values given to each.

Capacity of Plant.

Interest on first cost..... 6 per cent.

Depreciation..... 10 per cent to 20 per cent.

Operation.

Maintenance.

Car storage.

Switching charges.

Capacity of Plant. — In addition to the tons of coal handled per day, the storage capacity of the plant should be considered.

Car Storage. — Car storage is usually much more expensive than storing in bins. Figuring a car holds 40 tons, and that it is worth a dollar a day, storage in cars costs $2\frac{1}{2}$ cents per ton per day.

Self-clearing cars can be unloaded into a hopper at from 5 to 6 cents less per ton than from flat-bottom cars by hand.

Switching. — When coal is delivered in self-clearing cars and dumped into a hopper, tracks can be arranged so that cars can be handled by gravity, without the need of a switcher, thereby reducing the cost of operation.

Two-pocket Plant, Single Track, Wood Structure. — Fig. 66 illustrates a two-pocket single-track McHenry coaling plant with dynamometer weighing device to each pocket so that the amount of coal taken by each tender can be recorded. Capacity 70 tons. Cost complete \$4000 to \$5500.

Four-pocket Plant, Single Track, Wood Structure. — Fig. 67 illustrates a four-pocket, single-track McHenry coaling plant with weighing device to each pocket. Capacity 140 tons. Cost complete \$8000 to \$9500.

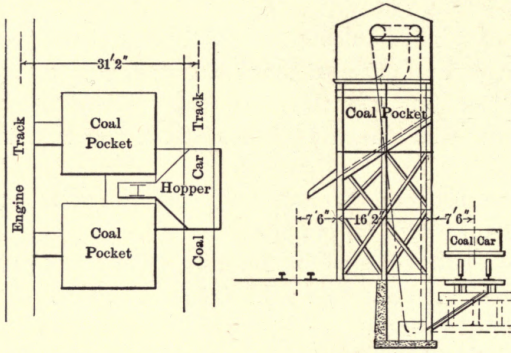

Fig. 66. Two-Pocket McHenry Coaling Plant.

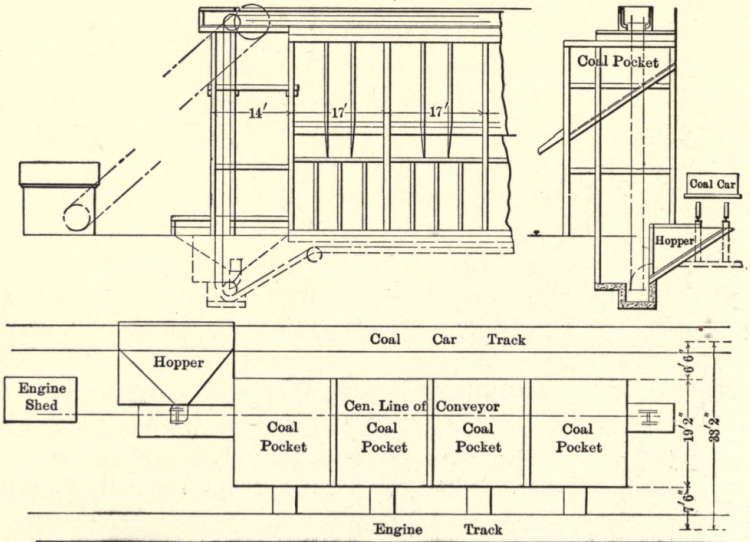

Fig. 67. Four-Pocket McHenry Coaling Plant.

In the two and four pocket plants the coal car is spotted over the hopper and dumped, the coal running by gravity into the boot, where it is hoisted by endless chain and bucket method to the pockets above. On the upper horizontal run the coal is scraped along the conveyor. Gates are provided to each pocket so that the coal may be dumped into any one desired by leaving the gate open. In the four-pocket plant the chains and buckets make an entire circuit round the house, the drive being set above the up-shaft end. The engine house with steam or gasoline power is placed a little beyond the coal structure, and a rope drive connects the engine with the main drive above. If desired, the mechanism can be motor driven direct or by pulley, thus dispensing with the engine house, when electric power can be obtained. The chain speed is 65 feet per minute and the power consumption about 12 to 15 horsepower. The space under the pockets may be boarded and used for storage purposes.

Four-pocket, Three-track Plant, Wood Structure.— Fig. 68 illustrates a four-pocket, 150-ton elevated capacity, three-track coaling plant. Cost complete \$10,000 to \$12,000 with dynamometer weighing device to each pocket, so that the amount of coal taken by each tender is recorded. Under the elevated pockets next to the coal hopper the space is boarded and used for storage purposes if desired, gates being provided so that the coal can flow back into the hopper and be re-elevated when necessary.

This structure is a modification of the McHenry type of coaling plant, and consists of two double elevated coal pockets, located between three tracks and connected together on top by a house spanning two tracks; the bottom hopper, into which the coal is dumped, is located behind the main pocket on one side, and is elevated 6 feet 6 inches above the locomotive service track, and made wide enough to take side-dump as well as center-dump cars.

The elevating mechanism consists of endless chain and buckets and a steel boot. From the bottom of the hopper the chain is carried up and over the house across the tracks, returning under the floor, and back to the boot. The drive is run by electric motor controlled by a switch on the ground near the coal dump hopper for the convenient use of the operator.

When the coal is dumped into the hopper it flows by gravity into the boot, regulated by a gate, and is picked up by the endless

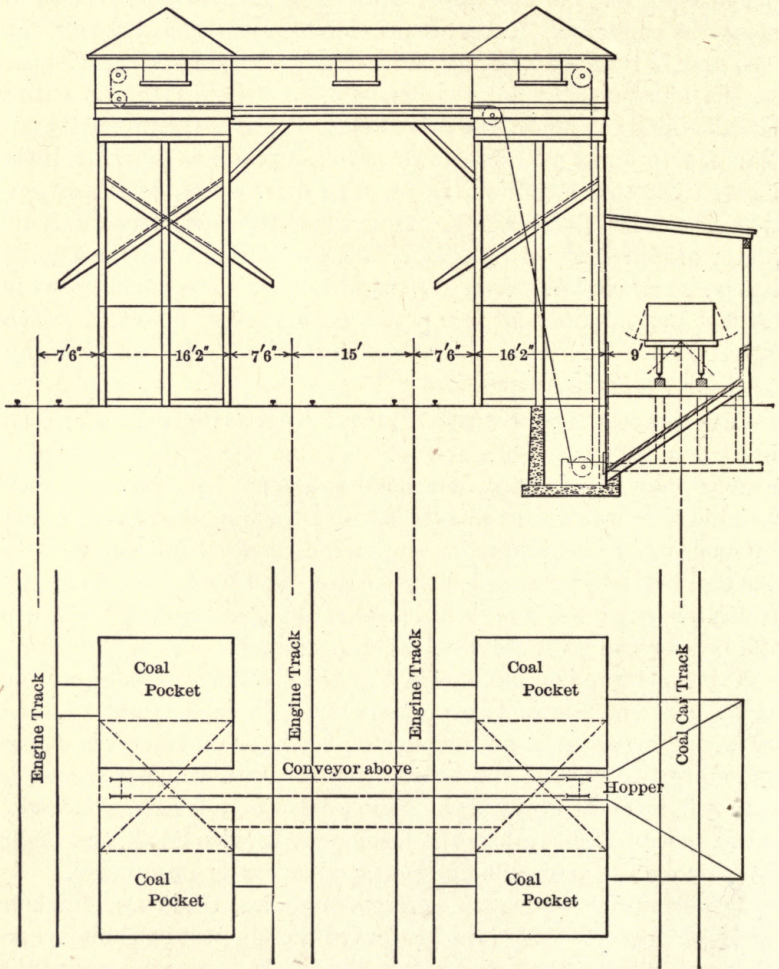

Fig. 68. Three-Track Coaling Plant.

buckets and hoisted up to the elevated pockets above and along the horizontal trough over the track. Openings with slide doors and chutes are arranged to supply any pocket with coal when desired. The chain speed is 65 feet per minute and the power consumption about 20 horsepower.

Sand Tower. — With the foregoing arrangement three tracks are provided for coaling locomotives, and the space between the elevated pockets facing the track may be used as a sand tower, so arranged that sand can be furnished on two tracks, the sand being elevated by air pressure from a cylinder in the drying room through inclined pipes, the sand house being located between the two tracks about 50 feet ahead of the structure. The cost of the wood sand house lined with galvanized iron on the outside, including sand bins between coal pockets and all mechanism, averages from \$1200 to \$1500.

Balanced Bucket or Holman Type. (Fig. 69.) — The elevated pocket has a capacity of 350 tons. The coal car is spotted over the hopper and fed by gravity into two vertical cars that are alternately hoisted and lowered, one going up as the other comes down. The buckets are automatically fed and dumped by feed device and tripping arrangements, the buckets being designed to hold three tons and are self-clearing.

They are operated by hoist with cable drive and 25 horsepower motor controlled by the operator in the engine room. At a speed of 60 feet per minute 100 tons can be delivered to the elevated pocket per hour.

The approximate cost of the plant complete averages from \$12,000 to \$15,000.

Belt Conveyor. (Fig. 70.) — This plant may consist of one or a series of pockets with an inclined belt on a 25-degree slope, fed from a track hopper beneath the coal car track, the coal being delivered to the belt by automatic feeders.

A 30 inches wide belt, 180 feet run, with a speed of 100 feet per minute will deliver 50 tons per hour.

The belt and its supports with a gang walk is usually housed in and supported by trestle, under which the engine room is placed.

The coal pockets are wood construction usually, and a sand shed beneath the coal wharf can be arranged and the sand shot by air

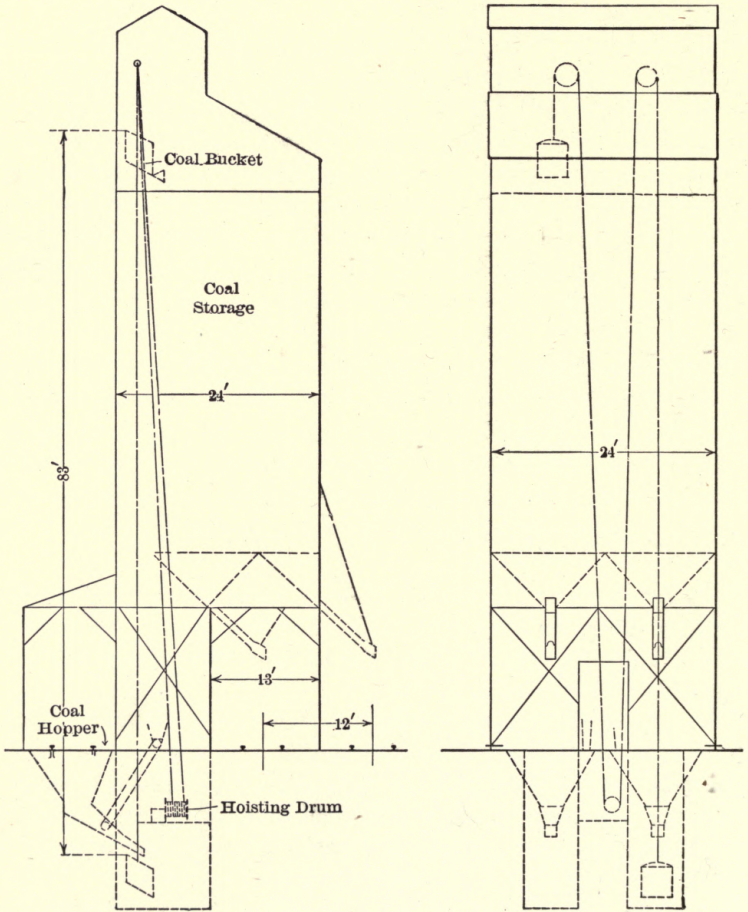

Fig. 69. Balanced Bucket Type Coaling Plant.

to a storage tank at the top of the bin, from which it is piped to the engines as required.

The approximate cost of a wooden structure, single pocket, 500 tons capacity plant, including sand house, etc., complete, averages from \$12,000 to \$18,000.

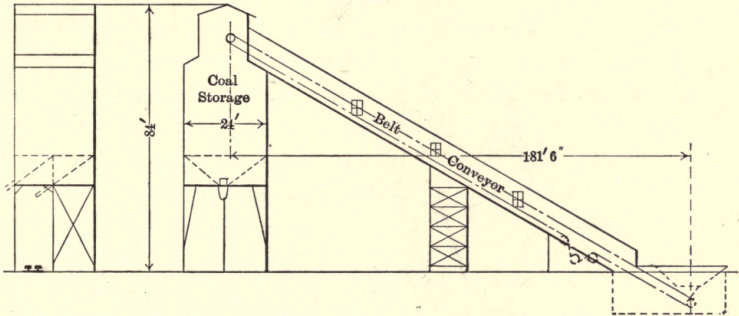

Fig. 70. Belt Conveyor Type of Coaling Plant.

Locomotive Crane. (Fig. 71.) — With the locomotive crane the coal is taken direct from flat-bottom cars by grab buckets and hoisted into the tender. When self-clearing cars are used a pit is constructed and the coal dumped, from which it is handled by the crane.

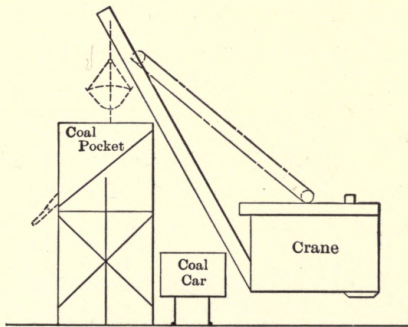

Fig. 71. Coaling Crane.

To avoid delays to locomotives elevated pockets are sometimes built and the coal hoisted by a long boom crane. With

proper structural facilities the crane can also handle cinders, and in some cases the sand, and is available at odd times for switching cars.

The cost of the locomotive crane set up complete depends on its capacity and may vary from \$5000 to \$9500 or more. The cost of storage pit and elevated pockets when desired is also a very variable quantity. In addition a certain amount of special track and yard room has to be figured.

A one-ton bucket and 42-foot boom crane with a 50-ton elevated pocket, including the extra track arrangement, would average \$7500 to \$9500.

The cost of handling coal by crane depends upon the scheme of coaling facilities and the work it can do in handling ashes, etc., at odd times.

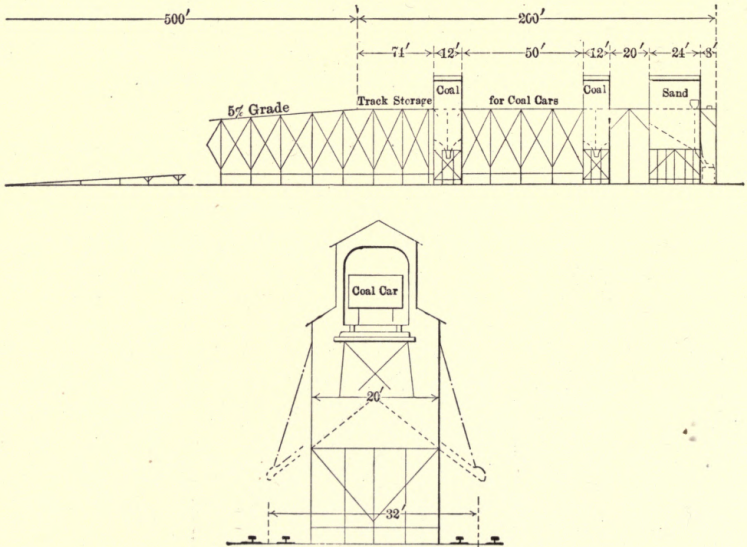

Fig. 72. Trestle Type Coaling Plant.

Elevated Chutes (Trestle Type). (Fig. 72.) — For flat-bottom car service where the coal is shoveled by hand into elevated bins, the trestle requires to be at least 25 feet above the engine track.

If the cars are pushed up the trestle by a switching engine,

the grade should not be more than 5 per cent; if by stationary hoisting engine, this can be increased to 20 per cent.

For the trestle type of coaling station the hoisting engine is considered the best way to elevate the coal. The switching of the cars on the trestle by ordinary locomotives is considered dangerous and expensive.

This plant consists of a wood trestle 5 per cent grade, with two 100-ton pockets and sand bin located between tracks.

The approximate cost complete is from \$15,000 to \$18,000.

Coal Storage.

Towers. — For hoisting coal from boats to storage pockets on wharfs, or coal storage adjacent to the wharfs, the elevated tower type of hoist is principally used, either built stationary on the wharf or arranged to run on track and trestle.

For quick service the one-man steeple type is used, requiring two engines, one operating the grab shovel and the other to run the trolley in and out on the boom.

The ordinary sizes and capacities are:

One-ton shovel, average capacity 400 to 500 tons per 10 hours.

Two-ton shovel, average capacity 600 to 700 tons per 10 hours.

Two and one-half-ton shovel, average capacity 700 to 800 tons per 10 hours.

Where favorable conditions exist the above capacities can be increased 50 to 100 per cent.

The bucket is operated by two steel wire ropes or flat link chains from independent drums on the hoisting engine, one closing the shovel in the coal while the other is hanging slack. When the shovel has been closed both chains are used to hoist it.

The operations of filling and dumping are automatic, excepting at the last, a few laborers are required for cleaning up.

Approximate cost. — As most all towers have to be built specially to suit the varying local conditions the cost is extremely variable, depending upon the condition of wharf, service required, etc. For estimating purposes \$20,000 to \$30,000 is a fair average price for one steel tower installed complete, with two-ton shovel.

Towers and Cable Railway. — When the storage yard is some distance from the wharf a cable railway is very often operated in conjunction with the coal hoists. The cable cars, holding one to three tons, are fed from the tower hopper and make a circuit or continuous loop around the building or yard on an elevated trestle track, automatically dumping the coal at any point desired.

The cost of trestle and cable railway system will vary with local conditions, storage capacity and service required. The cable car trestle may range from \$10 to \$50 per foot; the cable cars \$200 to \$300 each; the engine drives, power house, boilers, etc., are all too variable to give approximate costs that would be of any value.

When the coal is dumped on the ground it may be rehandled again by steam cranes into cars, tracks for which are usually provided.

Towers, Cable Railway, and Traveling Bridge.— When the storage and rehandling of coal are extremely large, the towers and cable railway are further supplemented with traveling bridges, which span the yard and transfer the cable cars across its length so that the coal can be dumped over the whole storage area. In some instances the entire plant — tower, cable railway, and bridge — moves together on the wharf.

Fig. 73 illustrates a scheme for handling enormous quantities of coal designed by the Mead Morrison Company of Chicago.

The coal is hoisted from the boats at the wharf by the ordinary tower cranes and hoppers into cable cars that circuit around the wharf and up the center of the storage yard on an elevated trestle. On either side of the yard is a traveling bridge which transfers the cable cars at any point across the yard. By this scheme all of the ground can be utilized for storage. The elevated coal pockets are arranged under the cable car trestle and car tracks run alongside. The coal is rehoisted from the pile from both sides of the bridge and trolleyed to the hopper ends, where it is redumped into the cable cars and run to the elevated storage or to any point desired.

A plant of this size would handle 2000 to 3000 tons per day, and the approximate cost of equipment installed complete would average \$350,000 to \$500,000.

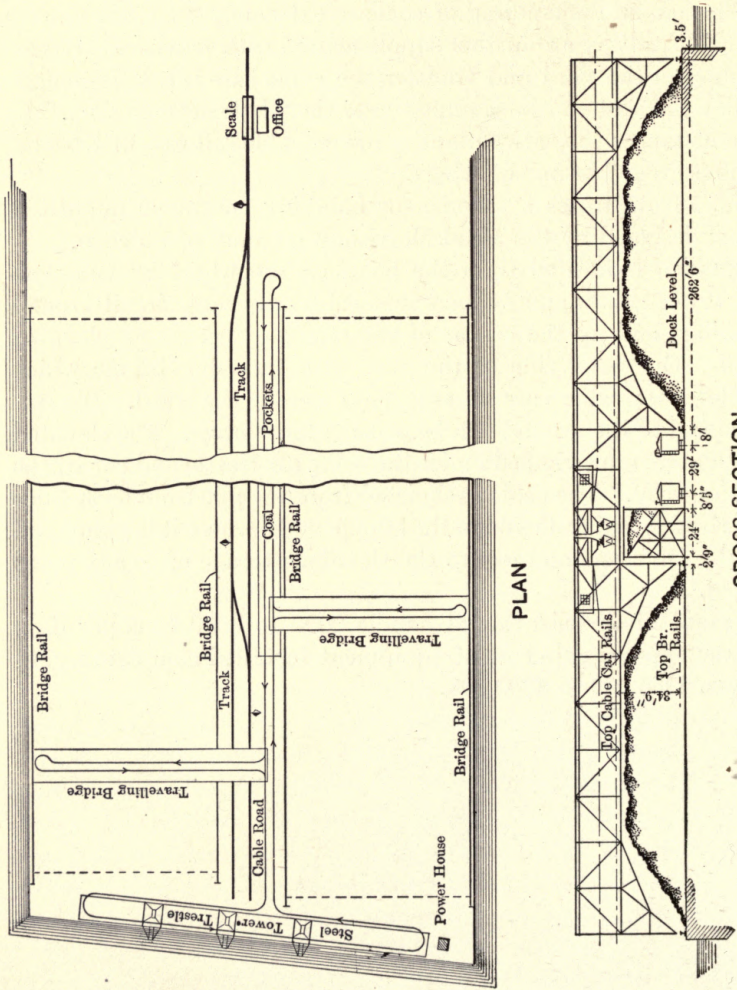

CROSS SECTION
Fig. 73. Coal Storage Plant.

Ash Pits.

Ash pits are required at divisional and other points so that ash pans of locomotives can be cleaned out.

The pits are usually placed convenient to the coal and water supply, and within easy reach of the turntable.

There seems to be a tendency at the present time to locate the ash pits inside or adjacent to the engine house, so that the work may be done under cover, and thus facilitate inspection with less engine movement.

The time required to clean a locomotive ash pan is from twenty to sixty minutes, depending on weather and other conditions, hence the type of ash pit to select depends on the number of engines to be handled and the time in which it has to be done.

Construction. — The walls are usually built of stone or concrete or 12" × 12" cedar timbers. When concrete is used a lining of fire brick is built on the inside face of walls, and when of timber old boiler plate is used. The lining of fire brick or other protection is necessary to protect the walls from the detrimental effect of hot ashes. On account of the wave action when the engines travel over the pit it is difficult to keep the rails anchored to the masonry, and for this reason wood stringers, or cast-iron rail chairs 3-foot to 4-foot centers are used frequently. The wood stringers are protected by a covering of sheet metal.

Water is used to cool the ashes, and this necessitates a water service with hose connection, valves, etc., and proper drainage. A sump hole 12 inches wide and 12 inches deep at one end of the pit, with the floor dished so as to drain to the sump, serves the purpose, the outlet to drain being placed on the side of the wall about 6 inches above the floor of sump.

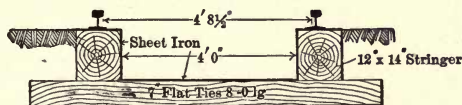

Fig. 74. Shallow Ash Pit.

Shallow Pit. (Fig. 74.) — This type of pit is built in long lengths, and necessitates sufficient help being on hand to remove the ashes promptly. It is also used for temporary work during construction and occasionally on main lines.

Approximate cost, \$5 to \$7 per lineal foot complete.

Deep Ash Pit, Closed Sides. (Fig. 75.) — The deep ash pit is constructed somewhat after the ordinary engine house pit, built

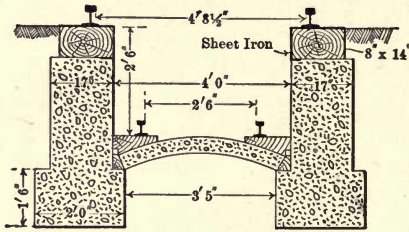

Fig. 75. Deep Ash Pit.

33 feet long and over. When two pits are placed on the same track they should be at least 50 feet apart. The ashes may be dumped directly into the pit and then shoveled out by hand, or small ash cars or buckets may be used under the engines to catch the cinders, the buckets being hoisted out by crane or air hoist when the track is clear.

Approximate cost, \$8 to \$10 per lineal foot without buckets or hoist. Cost, \$17 to \$35 per lineal foot with buckets and hoist. A pit 33 feet long with two ends would average \$300 complete.

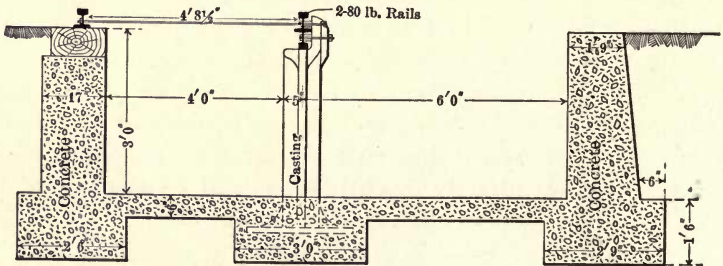

Fig. 76. Deep Open Ash Pit.

Deep Ash Pit, Open One Side. (Fig. 76.) — This pit is similar to Fig. 75, excepting that the pit is open on one side and the outer rail is supported by cast-iron posts. The ashes may be dumped and shoveled out by hand while the engine is over the pit, or small ash cars or buckets may be used to catch the cinders, arranged to be pulled out from the sides and then hoisted by

crane to dump into ash car. The latter method is known as the Ord type of ash pit.

Approximate cost, \$18 to \$25 per lineal foot without buckets or hoist. Approximate cost, \$35 to \$50 per lineal foot with ash buckets and air hoist.

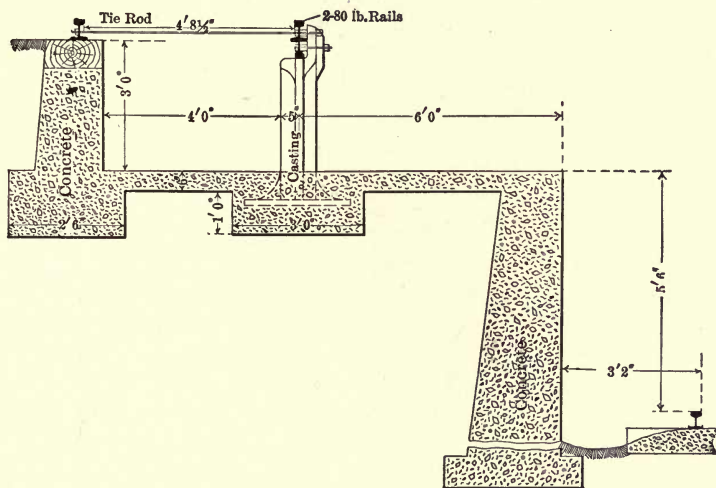

Fig. 77. Depressed Ash Pit.

Depressed Pit. (Fig. 77.) — This pit is similar to Fig. 76 with a depressed ash car track on the outside, the ashes being shoveled direct into the cinder car.

Approximate cost, \$25 to \$35 per lineal foot.

Mechanical Ash Plants.

Ashes are best handled in bulk, so that most mechanical plants are arranged to dump the ashes directly into small cars or buckets under the engine tracks, the small cars running on tracks at right angles to the pit so that they can be pulled out and hoisted by trolley, crane, or other device and automatically dumped into the cinder car.

Gantry Crane. (Fig. 78.) — The trolley beam is hinged at one end and is worked by air cylinder, with sheaves fastened to the gantry frame. The crane is moved along the track by

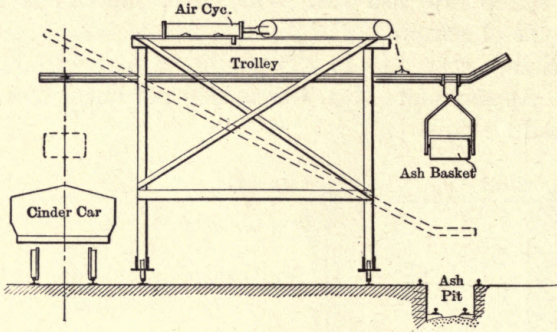

Fig. 78. Gantry Crane.

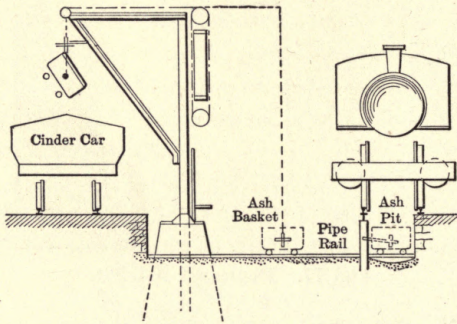

Fig. 79. Ord Ash Pit.

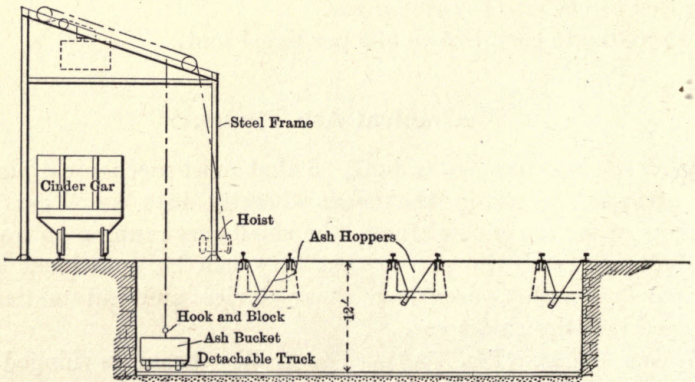

Fig. 80. Dump Bucket and Hoist.

geared hand wheels, one on each side, and the air is conveyed to the cylinder by hose pipe suspended on trolleys on an overhead wire. The supply of air is generally obtained from the engine or boiler house close by.

When the engines are off the ash pit, the gantry frame picks up the filled ash baskets and runs them by trolley to the ash car, where they are automatically dumped. By lowering the boom the basket is returned to the ash pit.

Approximate cost complete, with 6 ash baskets, \$800 to \$1200.

Ord Ash Pit. (Fig. 79.) — The ash baskets are placed under locomotive ash pan and pulled out from the side and hoisted by air crane and dumped without interfering with the movement of engines. The rails on which the ash baskets run are made of pipe, in which steam circulates, keeping the pit free of snow and preventing the water used in cooling the ashes from freezing.

Approximate cost of a single-track 30-foot ash pit with crane and four ash baskets complete, \$1200 to \$2000.

Dump Bucket and Hoist. (Fig. 80.) — The engines are cleaned out over the track hoppers and the ashes dumped and run into a detachable bottom dump bucket in the cross pit. A man in the pit operates the hopper gates and chutes and moves the buckets when filled, to the hoist, where they are raised and automatically dumped into the ash car. Perforated water pipes are placed around the sides of the ash hopper for cooling off the hot cinders. This type of pit is used by the Pennsylvania Railroad at Cleveland and Alliance.

Approximate cost of installation is said to be about \$5000.

Sand Houses.

At divisional and other points where engines are housed, provision is usually made to supply locomotives with sand to use in case of slipping on heavy grades or on account of climatic conditions. This generally consists of a small wooden house with an extension wet sand storage bin and an elevated dry sand box or tower, into which the sand is elevated by manual labor or some mechanical hoisting device or by blowing it through a pipe by compressed air, where it is stored and run by gravity to the sand box of the locomotive when required. The shed is generally arranged so that the wet sand can be conveniently delivered and shoveled from cars to the storage bin, the bin being sufficient to hold at least one carload. A small room is provided to house in the sand drier and hoisting mechanism, etc.

Instead of hoisting the sand into elevated hoppers, a platform is often used on which dry sand is placed in buckets arranged so that they can be easily handled by the enginemen, the platform being placed alongside the engine track on a level with the foot-board of engines.

The sand is dried by cast or sheet iron drying stoves, or by steam pipe troughs, and is generally screened before being placed for use.

The sand house is usually located in close proximity to the coal and water supply, so that engines when taking coal or water can at the same time obtain their supply of sand.

Approximate cost. (Fig. 81.) — 32 feet long, 13 feet wide, consisting of wet sand bin 16' \times 12', drying room 14' \times 12', small coal bin, sand drier and screen, compressed air cylinder and elevated sand tower, masonry foundation, \$700 to \$900. With wood foundation, balance as above, \$600 to \$700.

Construction. — Wood sills or masonry foundation, concrete floor in sand-drying house, frame walls, 2-inch plank on 4" \times 4" studs at 4-foot centers, lined on the outside with corrugated iron; no finish inside; roof, 3-inch plank with 6" \times 8" beam, tar and gravel finish; tower, 8" \times 8" posts well anchored to base at floor level, height about 30 feet from base of rail to center of sand storage, braced with 2" \times 6" horizontal and cross timbers; sand tower walls 2-inch plank with corner posts, roofed over with $\frac{7}{8}$ -inch T. and G. boards, covered with shingles and building paper between boards.

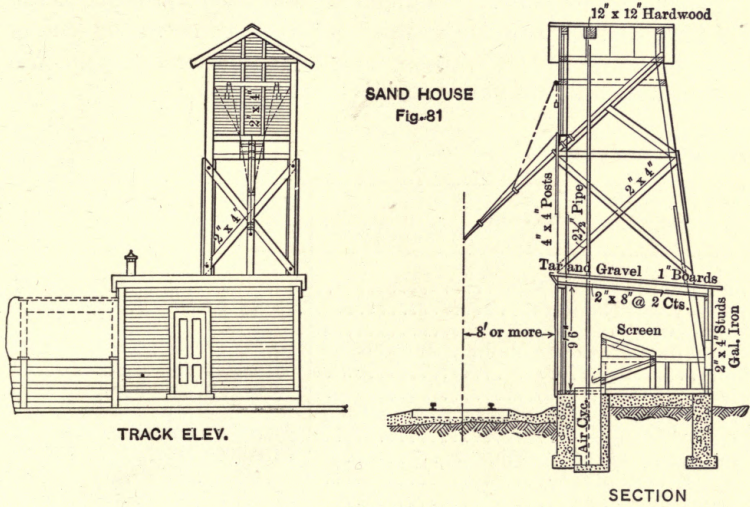
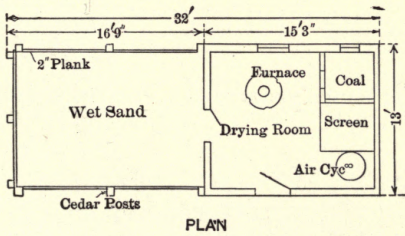

Fig. 81.



The tower is provided with sand valve and spout with rubber hose at end for running the sand to the engines.

Wet Sand Storage.—Two-inch plank walls supported by 8" × 8" posts about 8-foot centers, set on cedar sills on the ground, or the posts may extend into the ground 5 feet or thereabout; roofing 2-inch plank and 8" × 8" rafters, with tar and gravel finish. The length of wet sand bin varies to suit conditions.

Approximate estimate of cost.

Quantities.	Material.	Labor.	Total unit.	Cost.
40 cubic yards excavation			\$0.50	\$20.00
24 cubic yards concrete	\$3.50	\$3.50	7.00	168.00
8 cubic yards sand fill50	4.00
8000 feet board measure lumber, per thousand	18.00	17.00	35.00	280.00
2 doors	5.00	2.50	7.50	15.00
1 window	6.00	3.00	9.00	9.00
1 sand-drying furnace with cast-iron smoke jack and piping	20.00	23.00	43.00
1 compressed air sand cylinder	25.00	30.00	55.00
30 feet 2½-inch pipe16	.17	.33	10.00
1 glove valve	1.75	.50	2.25
1 drain cock75	.25	1.00
5 squares galvanized or corrugated iron, per square	4.00	3.00	7.00	35.00
Sand screen	2.00	.50	2.50
1 sway supply spout with connections	20.00	9.25	29.25
1½ squares shingles, per square (100 square feet)	2.00	2.00	4.00	6.00
4 squares tar and gravel roof, per square (100 square feet)	2.50	2.50	5.00	20.00
Painting	14.00	16.00	30.00
Concrete floor	8.00	12.00	20.00
				\$750.00
If wood foundation is used under sand-drying room, deduct				150.00
				<u>\$600.00</u>

Track Scales.

The ordinary railroad track scales for freight-car service are 100 to 150 tons capacity, and are usually placed on masonry foundations, with timber frame and platform, provided with dead and live rails.

The scales are usually placed between the receiving and separating yards, or on one side of the main yard, parallel with and next to the switching track convenient to the main line.

Size, 8 feet wide, 42 feet long, and about 6 feet deep, with extension on one side for the registering beam, and a shelter over for the weigher, when desired.

Approximate cost. — 100 tons capacity scale, masonry foundation, wood scale frame, registering machine, shelter, dead and live track, platform, etc., all complete, \$2600 to \$3600.

100 tons capacity scale, similar to above, with steel scale frame and cross ties (no dead track), all complete, \$2900 to \$3700.

125 tons capacity scale, similar to above, dead and live track, with wood scale frame, all complete, \$2800 to \$3400.

125 tons capacity scale, similar to above, with steel scale frame and cross ties (no dead track), all complete, \$3200 to \$3900.

150 tons capacity scale, similar to above, with wood scale frame, dead and live track, all complete, \$3000 to \$4000.

150 tons capacity scale, similar to above, with steel scale frame (no dead track), all complete, \$3500 to \$4500.

Construction. — Masonry walls, pedestals, and concrete floor with drain, usually built from plans supplied by the scale company.

Steel or timber frame for supporting the scale in accordance with the makers' details, including platform, registering scale box, dead and live track, etc.

Shelter 6 feet wide, 10 feet long, 8 feet high, frame building on cedar sills, 2 × 4 studs, double outside boards with paper between.

Double $\frac{7}{8}$ -inch floor on 2" × 4" joists, flat roof sloping away from scale, with 2" × 4" rafters, covered with $\frac{7}{8}$ -inch T. and G. boards and ready roofing. A small coal bin and a chimney are provided.

Approximate estimate of cost.

100-ton scales (timber scale frame), masonry foundations, etc.

120 cubic yards excavation at 50 cts.....		\$ 60.00	
75 cubic yards masonry at \$7.....		525.00	
7000 feet board measure timber at \$35.....		245.00	
300 pounds iron at 6 cts.....		18.00	
6-inch tile drain (100 feet laid) at 65 cts.....		65.00	
			<u>\$913.00</u>
Dead and live rails, 2 tons 60-pound steel at \$33.....	\$ 66.00		
6 pairs angle bars at \$50.40 per ton.....	3.00		
Bolts and spikes at \$62.50 per ton.....	4.00		
2 turnouts complete at \$237.....	474.00		
Laying switches and track.....	50.00		
			<u>597.00</u>
Installation of scales and freight.....	\$150.00		
Shelter.....	110.00		
			<u>260.00</u>
100 tons capacity scales (wood frame).....	\$650.00	\$1770.00	
Type registering machine.....	254.00	904.00	
			<u>\$2674.00</u>
Supervision and contingencies 10%.....			266.00
Total.....			<u>\$2940.00</u>

150-ton scales (steel scale frame).

140 cubic yards excavation at 50 cts.....	\$ 70.00		
90 cubic yards masonry at \$7.....	630.00		
4000 feet board measure timber at \$35.....	140.00		
12,000 steel at 4 cts.....	480.00		
6-inch tile drain (100 feet laid) at 65 cts.....	65.00		
			<u>\$1385.00</u>
Rails, 1 ton 60-pound steel at \$33.....	\$ 33.00		
3 pairs angle bars at \$50.40 per ton.....	1.50		
Bolts and spikes at \$62.50 per ton.....	2.00		
2 turnouts complete at \$237.....	474.00		
Laying track.....	40.00		
Installation of scales, freight, etc.....	300.00		
Shelter.....	110.00		
			<u>860.50</u>
150 tons capacity scale (steel frame).....	\$950.00		
Type registering machine.....	273.50		
			<u>1223.50</u>
Supervision and contingencies 10%.....			\$3469.00
			331.00
Total.....			<u>\$3800.00</u>

Stock Yards. (Fig. 80.)

Stock yards are erected at way stations and terminals for receiving cattle for shipment, and also for rest and feeding purposes for cattle en route. The yards are located parallel with the siding tracks convenient to the roadway at stock business points.

The ordinary wayside station stock yard consists of a series of fenced-in pens, with feeding and water troughs, including feed barns and shelters when necessary.

The terminal stock yards are usually housed in and are arranged with pens, feeding and water facilities, to suit the different classes of stock.

The usual arrangement is to provide loading and unloading platforms with chutes alongside the track. The platforms are made narrow so that the gates of the chutes when open shall come close to the cars for convenience in loading the cattle. The chutes lead to a main alleyway, from which the distribution of pens is arranged, the pens being divided to hold a car or portion of a car load, and made so as to open into one another and to branch alleyways in the center, so that the cattle may be sorted and classified if desired. Barns and shelters are erected on the branch alleyways for feeding purposes when necessary.

In addition to feeding and shelter sheds, water has also to be provided, with frost-proof hydrant valves to avoid freezing, the pipes being graded to drain when not in use.

Construction. — The construction generally is cedar posts 6 inches to 9 inches in diameter, placed 5 to 6 foot centers, set into the ground solid. The fencing is from 6 to 7 feet high, of 1 to 2 inch material, with 3 to 8 inch spaces between. Feed racks are placed on one or two sides, made with 2"×6" plank, the height and width varying to suit the stock. Water troughs are placed on the opposite side of feed racks, and are made of 2-inch plank supported on 2-inch plank brackets, with three-fourths to 1 inch water supply taken from a 1½-inch main and extending above the water trough with a goose neck. The floor, where the business amounts to anything, is usually of concrete finished rough.

An ordinary 20 car capacity stock yard would consist of a 4-foot platform placed 7 feet from rail, with 4 loading chutes

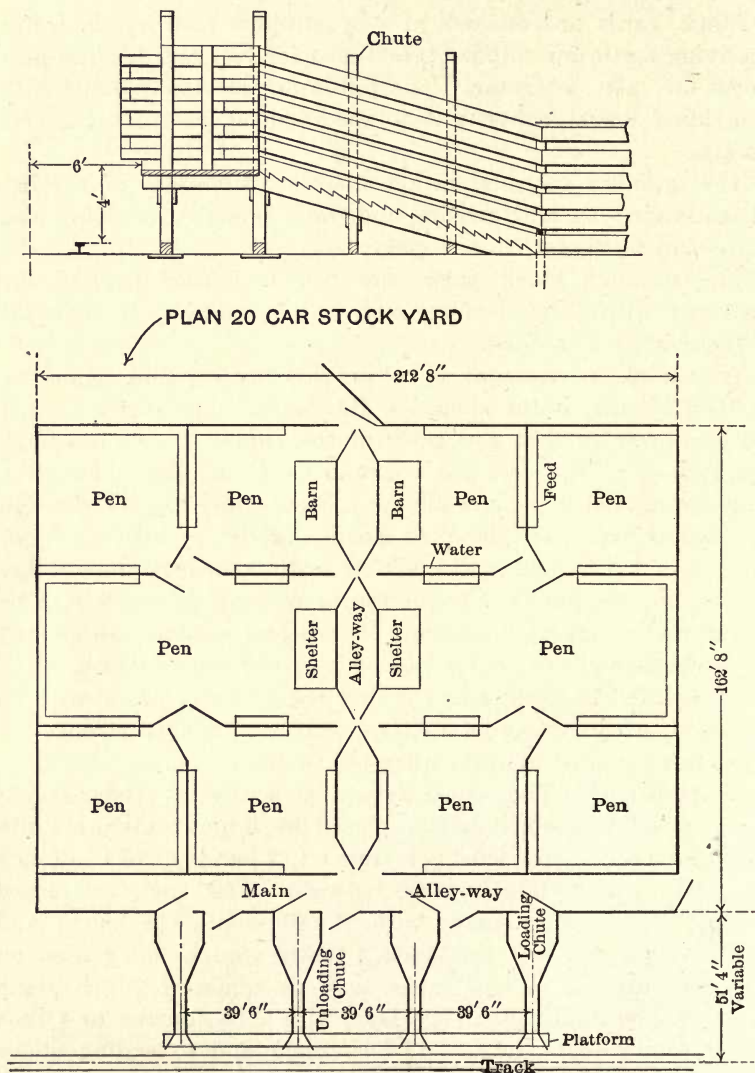

Fig. 82.

40-foot centers and 3 unloading chutes ramped down to main alleyway, the depth varying from 20 to 50 feet or more, and the depth of alleyway 12 to 13 feet by 200 feet long.

The area covered by the pens behind the main alleyway would be 213 feet long and 160 feet deep, divided into 10 pens, and one branch alleyway in the center 13 feet wide. The pens front and back would be $50' \times 50'$, and the center ones $50' \times 100'$. In the branch alleyways two shelters and two hay barns are erected projecting into the center pens as per Fig. 82.

Approximate cost. — The approximate cost of open stock yards with concrete floor averages from 20 to 35 cents per square foot of area covered.

The approximate cost of a 20 car capacity stock yard with feed racks, water troughs, hay barns, shelter, concrete floor, etc., complete, \$5500 to \$7500.

The cost of frame barns and shelters, from 50 to 75 cents per square foot.

The cost of enclosed stock yards, concrete floor for single-story frame buildings with skylights, etc., complete, varies from 65 to 90 cents per square foot when the amount is fairly large.

Snow Sheds.

Snow sheds are erected principally to protect the track from snow slides, and are designed to suit the varying conditions for each particular locality.

Level fall sheds are also built where excessive heavy falls of snow are frequent.

What might be termed a typical shed, Fig. 83, built with cedar crib on the inside to retain the earth, and rock backing from the original slope line, with roof over track, and trestle bent supports on the outside. The width of roadbed is made sufficient to take summer and winter tracks. The bents on the outside are spaced 4 to 8 feet apart and sheathed with plank 2 to 4 inches thick, depending upon the span.

Approximate cost, \$45 to \$80 per lineal foot of shed complete.

A gallery shed (Fig. 84) is built with round or square timbers in trestle fashion to carry slide protection back to slope, and the roof over the track. The gallery bents are built 4 to 12 feet apart, with run beams to carry the roof joists and planking.

Approximate cost, \$18 to \$45 per lineal foot of shed complete.

A valley shed (Fig. 85) consists of two cribs with earth and rock backing and roof over tracks. The cribs resist the impact from sliding masses of snow that may come from either side.

Approximate cost, \$70 to \$100 per lineal foot of shed complete.

The crib and gallery sheds (Figs. 86 and 87) are a combination of crib and gallery trestling to take the slope with roof over track and timber trestle bents on the outside.

Approximate cost, \$30 to \$60 per lineal foot of shed complete.

Level fall shed not exposed to slides. The side walls are built of round or square timbers sheathed with plank, with double-pitched roof over track, properly braced, with openings left for ventilation. The width varies from 16 to 18 feet, and the height 20 to 22 feet 6 inches clear, the bents being spaced from 5 to 12 feet apart.

Approximate cost, \$10 to \$15 per lineal foot of shed complete.

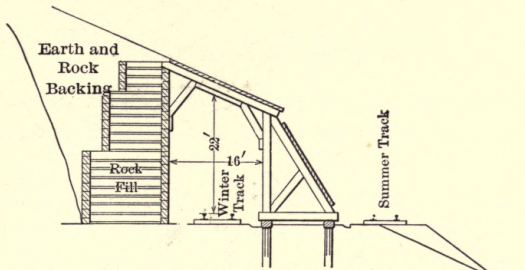

TYPICAL SHED
Fig.83

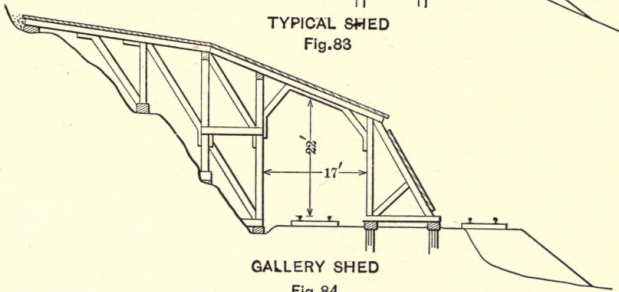

GALLERY SHED
Fig.84

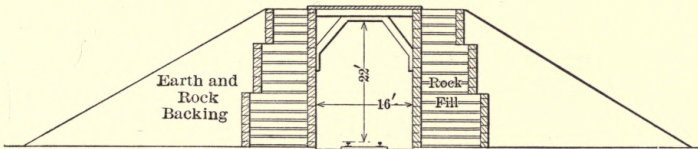

VALLEY SHED
Fig.85

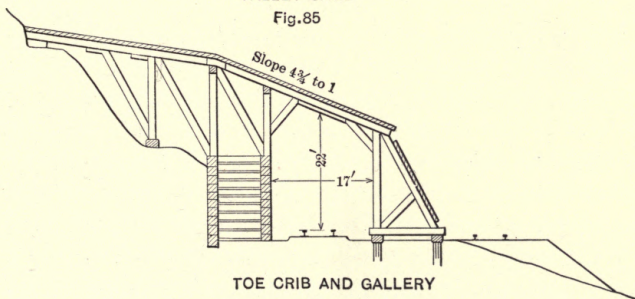

TOE CRIB AND GALLERY
Fig.86

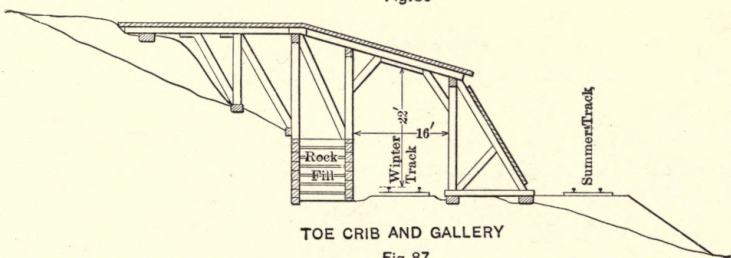

TOE CRIB AND GALLERY
Fig.87

Locomotive Turntables. (Fig. 88.)

The two types in use are the deck and half-through turntables varying in length from 60 to 100 feet, the average being about 70 feet.

The deck is used where foundation is suitable, and the half-through where it is necessary to reduce the depth of pit on account of the character of the ground.

When a large number of locomotives have to be turned an air or electric motor is installed. Ordinarily, however, they are moved by hand.

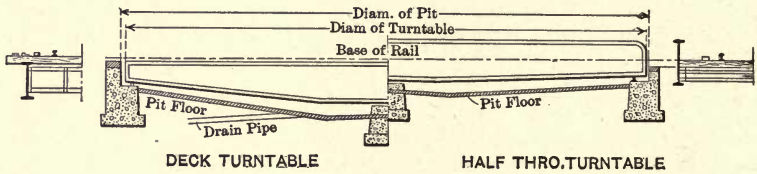

Fig. 88.

Approximate cost. — 70-foot turntable and pit, masonry walls and cinder floor, installed complete, \$7000 to \$8500.

70-foot turntable and pit, wood walls and earth floor, installed complete, \$4000 to \$5000.

Construction. — The turntable has solid main girders made up of steel plates and angles, with lateral and diagonal stiffening frames and braces, all shop riveted and shipped ready to drop into place and receive the floor. The table is supported on the center pier and pivots on conical rollers or steel balls encased in a box with bearing plates under, fox bolted to the masonry. The end trailing wheels on the circular rail are set with journal boxes in channel irons that go across and connect with the girders. The floor consists of wood ties dimensioned to suit the span, with an inner guard, and sometimes a narrow 2-inch plank sidewalk on either side.

The retaining walls and center pier may be built of wood, stone, or concrete, and the pit floor of cinders, good gravel, brick, or concrete.

The circular rail for the trailing wheels is usually bolted to the walls, and the ballast walls finished on top with hardwood timbers

laid flat in short lengths cut to radius for the inside face and held together with dog irons.

Approximate estimate of 70-foot half-through turntable and pit (Fig. 88). Girders, 12 foot 7 inch centers, 8" × 16" ties, 5" × 10" guard 7 foot 6 inch centers; diameter of pit, 71 feet 6 inches; height base of rail to circular seat, 2 feet 2 inches; width, 3 feet 9 inches from seat to pit floor; center pier, 5½ feet square and 3 feet 5 inches from base of rail to pier seat; depth of masonry, 5 feet below pit floor.

Masonry Foundations.—

998 cubic yards excavation at 50 cts.....	\$ 499.00
250 cubic yards concrete at \$8.50.....	2125.00
45 cubic yards broken stone or coarse gravel (pit floor) at \$2	90.00
1000 pounds iron at 6 cts.....	60.00
2½ tons of rail at \$33.....	74.25
¼ ton angle bars at \$51	12.75
9000 feet board measure timber floor per thousand at \$35	315.00
2600 feet board measure timber coping (hardwood) at \$45.....	117.00
60,000-pound steel turntable. F. O. B. cars, at 5½ cts.....	3200.00
60,000 pounds freight and erection at ¼ ct.....	450.00
1 grating.....	5.00
80 lineal feet 6-inch vitrified tile pipe, laid, at 65 cts.....	52.00
	<hr/>
	\$7000.00
Supervision and contingencies 10%	700.00
Total.....	<hr/>
	\$7700.00

Wood pits may be constructed for temporary work. This consists of a grillage of 12" × 12" timbers for center pier and ordinary ties sawn in two placed 2-foot centers for circular wall, set in gravel or cinder bed, with 12" × 12" posts well braced and 3-inch plank retaining wall sufficient for one track approach.

Approximate estimate of cost of 70-foot half-through turntable and pit. — *Wood Foundations.* —

General dimension above pit floor same as previous estimate.

284 cubic yards excavation at 50 cts.....	\$ 142.00
50 ties at 40 cts.....	20.00
2600 feet board measure (grillage) center pier per thousand at \$35	91.00
200 pounds iron at 5 cts.....	10.00
2½ tons of rail at \$33.....	74.25
¼ ton angle bars at \$51	12.75
60,000-pound steel turntable, F. O. B. cars, at 5½ cts.....	3200.00
60,000 pounds freight and erection at ¼ ct.....	450.00
9000 feet B. M. floor per M. at \$35.....	315.00
	<hr/>
	\$4315.00
Supervision and contingencies	400.00
Total.....	<hr/>
	\$4715.00

CHAPTER VI.

WATER STATIONS.

General. — The ordinary railroad water station usually consists of an elevated tank for storage purposes, a pumping outfit or gravity main to supply the tank, and standpipes when necessary for convenient service. A locomotive consumes from 30 to 100 gallons per mile, and carries from 2000 to 5000 gallons. Owing to mixed traffic, possible detentions and climatic conditions, however, it has been found necessary to place water stations 10 to 20 miles apart, usually at regular stopping points along the right of way.

Purity. — As the water is to be used principally for locomotive purposes, a sample should be sent to the company's chemist to be analyzed to ascertain if it is suitable for the purpose. Conditions will sometimes make it necessary to treat the water chemically to render it soft for economical boiler service.

The treatment may be lime only, when the hardness is due to carbonates of lime and magnesia, or soda ash when the hardness is due to sulphates of lime and magnesia. The method of applying these reagents to the water may require a special mechanical outfit, or a mixer with valve, feed, etc., connected with the water supply, can be so arranged that every stroke of the water piston may take in a desired portion of the chemical previously made ready. To render the work efficient, it should be closely watched and supervised by the company's chemist or his assistant.

Supply. — When a municipal water service is established and the rates are favorable, there may be a saving in obtaining water by meter or other agreement. Under ordinary circumstances, however, the permanent supply is usually obtained from artesian or driven wells, or from a natural lake, river, or stream, and the delivery may be by gravity or by pumping, local conditions determining the method employed. A gravity supply usually requires a dam and spill-way for storage purposes. When the location is convenient and a permanent and abundant supply can be obtained in a natural or artificial basin, a gravity supply is the most economical. For description and cost of dams, see page 203.

Tanks. — The amount of water storage required for locomotive purposes depends entirely on local conditions. Ordinarily a tank holding 40,000 to 50,000 gallons of water is about the average in use, although 60,000 and 100,000 gallon tanks are very common, and in some instances the storage tanks are as low as 6000 gallons. For description and cost of water tanks, see page 197.

Standpipes. — Duplication of water service is obtained by the use of water columns or standpipes. For description and cost, see page 201.

Pumps. — When practicable the pump is placed under the tank, or in a separate pump house when the source of supply renders it necessary. For description and cost of pump house, see page 196.

The pump may be operated by air, motor, steam, gasoline, oil, gas, or electric motor, and in some instances by the hydraulic ram driven by the fall or force of running water.

The most popular in common use is the duplex type of steam pump, with an independent vertical boiler to supply steam to operate the pump, or a steam pipe is run from the local boiler house when convenient and the pump boiler dispensed with.

The gasoline direct-connected combined pumper is also favored to a large extent.

When selecting or investigating a pump, the following information is necessary:

- (a) Maximum quantity of water to be pumped per minute.
- (b) Height to be lifted by suction.
- (c) Length and diameter of suction pipe and number of angles or turns.
- (d) Height to which water has to be forced, from pump to top of tank.
- (e) Length and diameter of delivery pipe and number of angles or turns.
- (f) Pressure of steam to be used.

When the above information is known the following should be estimated:

- (a) Capacity (Table 43).
- (b and d) Lift (Table 44).
- (c and e) Pipe friction (Table 45).
- (f) Power to be provided to raise the water, to overcome the friction of the water in pipes, and bends, and to overcome the friction in pump, and connections to the engine.

The lift and pipe friction pressures equal the total pressure against which the pump has to work, and the area of the water cylinder multiplied by this pressure equals the total resistance.

The area of the power cylinder multiplied by the working pressure equals the total power pressure, and the ratio of power to resistance must be sufficient to move the piston at the required speed. For this, an excess of 33 to 50 per cent is usually allowed. When the capacity, lift, and friction heads are figured, the power necessary to drive the pump may be obtained from Table 46.

As it is not necessary to deliver the water to the tank at high pressure, steam economy is obtained when the ratio of steam and water piston area is proportioned for the actual conditions, using, of course, the nearest commercial size pump.

Approximate cost. — Pumps, boilers, etc., with approximate cost for the ordinary run of tank service, may be obtained from Table 39, with comparative estimates for steam, oil, and gasoline outfits on page 179.

Example. — *A*, equals 200 gallons per minute; *B*, 15 feet (pump set directly over well); *C*, suction pipe 5 inches diameter, 15 feet deep in well, one elbow; *D*, 45 feet; *E*, 4 inches diameter, delivery pipe 5000 feet in length, two elbows; *F*, 80 pounds boiler pressure.

Lift or actual head (*B* + *D*) = 15 + 45..... equals 60 feet.

Pipe friction (*C*) 5-inch pipe 15 feet long

(Table 45) $.42 \times \frac{15}{100}$ equals .063

1 5-inch elbow (Table 45a) equals .068

(*E*) 4-inch pipe 5000 feet long + 60

feet = 5060 feet = $1.22 \times \frac{5060}{100}$ equals 61.732

2 4-inch elbows = $.172 \times 2$ equals .344

Total pipe friction equals 62.207

Equivalent height of water for friction

pressure = 62.207×2.3 * equals 143 feet.

Total head against which the pump has

to work..... equals 203 feet.

Referring to Table 39, under 205 feet head an 8" × 5" × 12" pump is given.

* 2.3 = height of water for 1 pound per square inch pressure.

Power. — Horsepower necessary to raise water (Table 46)

$$= \frac{200 \times 8\frac{1}{2} \times 203}{33000} = 10.3 \text{ horsepower.}$$

Pump friction, back pressure,
and steam losses say 40 per cent = 4.12 horsepower.

Total, 14.42 horsepower.

Engine Horsepower. Page 193. — Assuming that the engine is running 100 strokes per minute, and (*F*) 80 pounds boiler pressure, cutting off one-fourth stroke.

$$\text{Horsepower} = \frac{47.7 \times 1 \text{ foot} \times 2 \times 50.26 \times 100}{33000} = 14.5.$$

Lift and pipe friction pressure = (203 feet) = 87.93 pounds.

Area of water cylinder (5 inches) = 19.63.

Total resistance = $19.63 \times 87.93 = 1735$ pounds.

Area of steam cylinder (8 inches) = 50.26.

Working pressure = 47.7 pounds.

Total power pressure = $50.26 \times 47.7 = 2397$ pounds.

Ratio of power to resistance = 1.4 to 1, or 40 per cent.

TABLE 39.— DUPLEX STEAM PUMPS AND BOILERS. DATA OF CAPACITY AND APPROXIMATE COST, ETC.

Capacity U. S. gal- lons, 100 strokes per min.	Equivalent.		Pumps.			Pipes.				Approx. cost of pumps.	Boilers.					Approx. cost of boiler.	Approx. total cost pump and boiler in place.
	Head.	Press.	Steam.	Water.	Stroke.	Suction.	Discharge.	Steam.	Exhaust.		H.P.	Diameter.	Height.	2-in. tubes.			
														Number.	Length.		
65	185	80	6	4	6	4	3	1	1½	\$100	5	24	60	31	18	\$105	\$250
102	115	50	6	5	6	4	3	1	1½	120	5	24	60	31	18	105	270
119	115	50	6	5	7	5	4	1	1½	135	10	30	72	54	27	150	350
119	155	68	7	5	7	5	4	1	1½	150	10	30	72	54	27	150	360
136	115	50	6	5	8	5	4	1	1½	160	10	30	72	54	27	150	380
136	155	68	7	5	8	5	4	1	1½	170	12	30	84	54	38	160	400
170	155	68	7	5	10	5	4	1	1½	240	15	36	84	68	38	190	500
171	110	47	7	6	7	5	4	1	1½	200	10	30	72	54	27	150	420
171	145	63	8	6	7	5	4	2	2½	230	15	36	84	68	38	190	510
204	205	89	8	5	12	5	4	2	2½	260	20	42	96	85	48	230	600
232	80	35	7	7	7	6	5	1½	2	200	10	30	72	54	27	150	420
244	110	47	7	6	10	5	4	1½	2	260	15	36	84	68	38	190	540
244	145	62	8	6	10	5	4	2	2½	270	20	42	96	85	48	230	600
266	105	46	8	7	8	5	4	1½	2	280	15	36	84	68	38	190	570
266	165	71.4	10	7	8	5	4	2	2½	320	20	42	96	85	48	230	660
283	145	62	8	6	12	5	4	2	2½	290	20	42	96	85	48	230	630
283	225	98	10	6	12	5	4	2	2½	310	40	48	114	128	57	420	880
283	325	140	12	6	12	5	4	2½	3	460	50	54	114	174	57	660	1350
332	80	35	7	7	10	6	5	1½	2	300	15	36	84	68	38	190	600
398	105	45	8	7	12	6	5	1½	2	315	20	42	96	85	48	230	660
398	165	71.4	10	7	12	6	5	2	2½	370	40	48	114	128	57	420	950
398	240	103	12	7	12	6	5	2½	3	460	50	54	114	174	57	660	1350
398	325	140	14	7	12	6	5	2½	3	530	70	54	Hor.	40	192	770	1560
522	80	35	8	8	12	6	5	1½	2	510	20	42	96	85	48	230	900
522	125	54	10	8	12	6	5	2	2½	530	40	48	114	128	57	420	1140
522	182	78.75	12	8	12	6	5	2½	3	540	50	54	114	174	57	660	1440
522	250	108	14	8	12	6	5	2½	3	590	70	54	Hor.	40	192	770	1650
522	325	140	16	8	12	6	5	2½	3	690	100	66	Hor.	60	192	1050	2100
816	50	22	8	10	12	6	5	2	2½	570	20	42	96	85	48	230	960
816	115	50	12	10	12	6	5	2½	3	600	50	54	114	174	57	660	1520

Combined Engine and Pump.

The combined engine and pump is a self-contained unit run principally by gasoline or oil. In many localities it will be more economical than the ordinary steam pump and boiler to operate, although higher in first cost.

Their use is not as well known as the steam pump. The handling of oil or gasoline and repairs are matters that require special attention. They are gradually, however, coming into favor, and may eventually be as common as the steam pump.

TABLE 40. — APPROXIMATE COST, ETC.

Horse-power.	Adjustable stroke, inches.	Strokes per minute.	Cylinder, inches.	Gallons per minute pump displacement.	Ft. head.	Suction.	Discharge.	Approximate cost in place.
5	8, 9, 10	91	4½-7	51-137	96-259	3-4	3-4	\$ 600
8	8, 9, 10	97½	5-7	66½-146	145-319	4	4	900
10	8, 10, 12	100	7-8½	133-295	90-200	6	5	1200
15	8, 10, 12	105	7-8½	140-310	127-281	6	5	1600
20	8, 10, 12	110	7-8½	147-324	163-360	6	5	2000
25	8, 10, 12	109½	8-10½	215-494	134-356	7	6	2300

COST OF PUMPING WATER. COMPARISON ESTIMATES BETWEEN STEAM, OIL, AND GASOLINE.

Conditions. — Pump to deliver 200 gallons per minute working 10 hours per day and 300 days per year, against an equivalent head of 200 feet, or 10 theoretical horsepower.

STEAM PUMP AND BOILER. —

One 8×5×12 pump and boiler complete, from Table 39.....	\$540.00
Connections and contingencies.....	60.00
Total.....	\$600.00

Cost of Operating. —

Assuming 20 pounds of coal per horsepower hour=200 pounds×10 hours=1 ton×300=300 tons per year at \$2.25.....	\$675.00
Attendance by station agent or portion of a regular pumpman's time at \$10 per month.....	120.00
Oil and waste.....	25.00
Repairs and maintenance.....	50.00
Total per year.....	\$870.00

or \$2.90 per day, or 29 cents per hour, or about $2\frac{1}{2}$ cents per 1000 gallons. If necessary to have a pumpman all the time, \$300 more would have to be added for his wages, making the cost about $3\frac{1}{4}$ cents per 1000 gallons.

OIL COMBINED PUMPER. —

8×12 pump direct connected, from Table 40.....	\$1200.00
Connections and contingencies.....	120.00
	<hr/>
	\$1320.00

Cost of Operating. —

Coal oil 15 cents per gallon.	
Assuming $1\frac{1}{2}$ cents' worth of coal oil per horsepower per hour, including waste and handling = $10 \times 1\frac{1}{2} = 15$ cts. $\times 10 = \$1.50 \times 300$..	\$450.00
Attendance by station agent or portion of a regular pumpman's time at \$10 per month.....	120.00
Lubricating oil and waste.....	30.00
Repairs and maintenance.....	90.00
	<hr/>
Total.....	\$690.00

or \$2.30 per day, or 23 cents per hour, or 1.9 cents per 1000 gallons. If necessary to have a pumpman all the time, \$300 more would have to be added for his wages, making the cost about $2\frac{3}{4}$ cents per 1000 gallons.

GASOLINE COMBINED PUMPER. —

8×12 pump direct connected, from Table 40.....	\$1200.00
Connections and contingencies.....	120.00
	<hr/>
	\$1320.00

Cost of Operating. —

Gasoline 18 cents per gallon.	
Assuming $\frac{1}{10}$ imperial gallon per horsepower hour = 1 gallon = 18 cts. $\times 10 = \$1.80 \times 300$	\$540.00
Attendance by station agent or portion of a regular pumpman's time at \$10 per month.....	120.00
Lubricating oil and waste.....	30.00
Repairs and maintenance.....	90.00
	<hr/>
	\$780.00

or \$2.60 per day, or 26 cents per hour, or 2.2 cents, about, per 1000 gallons. If necessary to have a pumpman all the time, \$300 more would have to be added for his wages, making the cost about 3 cents per 1000 gallons.

It will be noted from the foregoing that the approximate cost of pumping water is as follows:

Oil engine.....	1.9 to 2.75 cents per 1000 gallons.
Gasoline engine.....	2.2 to 3.00 cents per 1000 gallons.
Steam pump and boiler....	2.5 to 3.25 cents per 1000 gallons.

There are many elements that enter into the cost of pumping water that may bring the figures up to double the amounts given. The sizes of suction and discharge pipes are quite as important as the pumps, and if these are figured too small, poor results will be obtained at an additional cost.

The question of using oil, gasoline, or steam depends a good deal on the location and existing conditions and the means at hand for having them looked after in case of repairs. Fuel supply, including depreciation and first cost, have also to be considered.

Boilers.

The general run of boilers to supply steam to the pump range from 5 to 100 horsepower, and the plain vertical tube boilers are chiefly used.

The boiler pressure must be somewhat in excess of the steam pressure at the pump, to allow for loss of steam pressure between the boiler and pump.

The boiler horsepower is usually reckoned on the A. S. M. E. basis of 30 pounds of water evaporated or consumed per indicated horsepower and from 12 to 15 square feet of heating surface in the boiler are usually reckoned for the generation of one horsepower per hour.

Each nominal horsepower of boilers requires about 10 gallons of feed water per hour (30 to 35 pounds).

Good boilers will evaporate from 5 to 10 pounds of water per pound of coal.

One square foot of grate surface natural draft will consume 10 to 15 pounds hard coal or 20 to 25 pounds soft coal per hour, or an average consumption of 10 pounds of coal per cubic foot of water evaporated (12 pounds per hour for each square foot of grate surface).

The boiler should be set up on a good solid foundation, with smoke flue protected at roof or outlet to avoid danger from fire.

The cost of the general run of vertical boilers is given in Table 39.

Service Connections.

The discharge pipe should enter the water tank at the bottom, as it reduces the head and takes less power than feeding it from the top.

Provide a check valve in delivery pipe and a waste cock in the discharge chamber, so that air may be expelled, a stop valve for shutting off the back pressure, so that the pump can be opened for inspection.

Set up the pump on solid foundation of concrete; wood is liable to rot and cause leaky joints. To obviate jar or vibration, use expansion bolts to anchor the pump.

Arrange the steam pipe feed so that the water of condensation will drip away from the pump when not in use, and insert drip cock.

An air chamber on the suction pipe will make the pump work smoother at moderate speed, and is advisable, as it prevents pounding or water hammer; in high lifts it is a necessity.

Unless the suction lift and length of supply pipe are moderate, a foot valve and strainer are also advised for all pumps raising water by suction.

The foot valve is placed at the bottom of the suction pipe and holds the priming.

The suction pipe must be entirely free from all leakage.

Lay suction pipes with a uniform grade from the pump to the source of supply, and avoid air pockets. All pipes should be as direct as possible; use full round bends for elbows and Y's for tees.

Service Pipe. — Steel riveted, cast-iron, plain wrought-iron, and galvanized iron pipe are used extensively; cast iron is the most durable and reliable for underground service, and above ground plain wrought-iron pipe proves quite satisfactory; for weight of pipes, etc., see Tables 41 and 42.

The depth to which pipe should be placed in the ground should be sufficient to avoid injury from frost, usually 4 to 5 feet. A water main laid in a rock-cut trench is less liable to freeze up if covered with broken stones.

Pipes.

Cast Iron. — All cast-iron pipes and fittings must be uncoated, sound, cylindrical and smooth, free from cracks, sand holes, and other defects, and of a uniform thickness and of a grade known in commerce as "extra heavy," cast in lengths to lay twelve feet, with bell and spigot joints; and to withstand a static pressure of not less than 130 pounds per square inch.

TABLE 41. — APPROXIMATE COST AND WEIGHT OF CAST-IRON WATER PIPE.

Diameter pipe.	Thick-ness.	Weight per lineal foot.	Feet per ton.	Number of lengths per ton.	Approximate cost per foot at \$35 per ton.	Approximate cost per foot at \$40 per ton.	Actual Cost.
Ins.	In.	Lbs.					
2	$\frac{3}{8}$	8	250	21	\$0.14	\$0.16
3	$\frac{7}{16}$	15	133	11.1	.26	.30
4	$\frac{1}{2}$	19	105	8.8	.33	.38
5	$\frac{1}{2}$	26	77	6.4	.45 $\frac{1}{2}$.52
6	$\frac{9}{16}$	32	62.5	5.2	.56	.64
7	$\frac{9}{16}$	40	50	4.2	.70	.80
8	$\frac{5}{8}$	47	44.5	3.7	.82 $\frac{1}{2}$.94
10	$\frac{5}{8}$	63	31.9	2.8	1.10	1.26
12	$\frac{11}{16}$	82	24.4	2.0	1.43	1.64

Joints. — All joints must be made with picked oakum and molten lead and made water-tight. For estimating, take 1 $\frac{1}{2}$ pounds of soft pig lead for each joint for each inch in the diameter of the pipe, and 1 ounce of oakum for each joint for each inch in the diameter of the pipe.

Fittings. — Ordinary cast or malleable iron water fittings.

Wrought-Iron and Steel Pipes. — All wrought-iron and steel pipes must be equal in quality to "standard."

The pipes shall be not less than the following average thickness and weight per lineal foot; supplied in random lengths with threads and couplings.

TABLE 42. — APPROXIMATE COST AND WEIGHT OF WROUGHT-IRON PIPES.

Inside size of pipe.	Thickness.	Normal weight per lineal foot.	Approx. cost per 100 feet.	Approx. cost per lin. foot.	Actual cost per lin. foot.
Ins.	In.	Lbs.	Dols.	Dols.	Dols.
1	.13	1.67	6.00	.06
1½	.14	2.68	9.00	.09
2	.15	3.61	13.00	.13
2½	.20	5.74	23.00	.23
3	.21	7.54	30.00	.30
3½	.22	9.00	45.00	.45
4	.23	10.66	54.00	.54
4½	.24	12.49	63.00	.63
5	.25	14.50	72.00	.72
6	.28	18.76	93.00	.93
7	.30	23.27	116.00	1.16
8	.32	28.18	141.00	1.41
9	.34	33.70	168.00	1.68
10	.36	40.00	200.00	2.00
11	.37	45.00	225.00	2.25
12	.37	49.00	245.00	2.45

Joints. — All joints to be screwed joints made up with red lead.

Fittings. — Ordinary cast or malleable iron water fittings.

Formulas.

Capacity. — The capacity of a pump depends upon the speed at which it can be run, and the speed depends largely on the arrangement of valves and passageways for water and steam; ordinarily it is reckoned by the gallons per minute the pump plunger can deliver at the average speed of piston travel.

For short-stroke pumps, generally used in railroad water tank service, the piston travel may be rated at 100 strokes per minute.

$$\text{Capacity per stroke in gallons} = \frac{\text{stroke} \times \text{area}}{231}.$$

231 = cubic inches in a gallon of water.

TABLE 43. — CAPACITY OF PUMPS PER STROKE IN GALLONS (ONE PLUNGER).

Diam-eter. water cylin-der.	Area water cylin-der.	Length of stroke in inches.											
		5	6	7	8	9	10	12	14	16			
In.	Sq. in.												
4	12.56	.272	.326	.381	.435	.489	.544	.652	.761	.870			
5	19.63	.425	.51	.595	.68	.765	.85	1.02	1.19	1.36			
6	28.27	.612	.734	.877	.979	1.101	1.224	1.468	1.713	1.958			
7	38.48	.833	.999	1.166	1.332	1.499	1.666	1.999	2.332	2.665			
8	50.26	1.088	1.305	1.523	1.740	1.958	2.176	2.611	3.046	3.481			
9	63.61	1.377	1.652	1.928	2.203	2.478	2.754	3.304	3.855	4.406			
10	78.54	1.7	2.04	2.38	2.72	3.06	3.4	4.08	4.76	5.44			
11	95.03	2.057	2.464	2.879	3.291	3.725	4.113	4.936	5.759	6.582			
12	113.09	2.448	2.937	3.422	3.916	4.406	4.896	5.875	6.854	7.833			
14	153.93	3.331	3.997	5.33	5.996	6.663	7.994	9.328	10.66			
15	176.71	3.824	4.589	6.119	6.884	7.649	9.178	10.70	12.23			
16	201.06	4.35	5.22	6.96	7.83	8.703	10.44	12.18	13.92			

Gallons delivered in one minute equal capacity per stroke multiplied by strokes per minute. For duplex piston or plunger, multiply by 2. For triplex piston or plunger, multiply by 3.

Example. — What quantity of water is delivered per minute with a duplex pump 5-inch water and 7-inch stroke, piston speed 100 strokes per minute? *Ans.* $.595 \times 2 \times 100 = 119$ gallons per minute.

Speed. — A piston travel of 100 feet per minute is the basis generally used for rating the capacity of a pump. If short-stroke pumps, however, are run at this speed they would not be durable for every-day service, and 100 strokes rather than 100 feet is a more reasonable service.

At a piston speed of 100 feet per minute the pump would have to make the following strokes:

- Three-inch stroke pump, 400 strokes per minute.
- Four-inch stroke pump, 300 strokes per minute.
- Five-inch stroke pump, 240 strokes per minute.
- Six-inch stroke pump, 200 strokes per minute.
- Seven-inch stroke pump, 171 + strokes per minute.
- Eight-inch stroke pump, 150 strokes per minute.
- Nine-inch stroke pump, 133 + strokes per minute.
- Ten-inch stroke pump, 120 strokes per minute.
- Eleven-inch stroke pump, 109 + strokes per minute.
- Twelve-inch stroke pump, 100 strokes per minute.

Lift. — The head of water against which the pump has to work, or the pressure due to the height to which the water has to be forced, is usually termed the lift, and expressed in pounds per square inch = height of water column \times .434.

.434 = pound pressure per square inch exerted by a column of water one foot high.

TABLE 44.— FEET HEAD AND EQUIVALENT PRESSURE IN POUNDS PER SQUARE INCH.

Ft. head.	Equiv. press. in pounds.	Ft. head.	Equiv. press. in pounds.	Ft. head.	Equiv. press. in pounds.	Ft. head.	Equiv. press. in pounds.
1	0.48	43	18.62	85	36.82	127	55.01
2	0.86	44	19.05	86	37.25	128	55.44
3	1.30	45	19.49	87	37.68	129	55.88
4	1.73	46	19.92	88	38.12	130	56.31
5	2.16	47	20.35	89	38.55	131	56.74
6	2.59	48	20.79	90	38.98	132	57.18
7	3.03	49	21.22	91	39.42	133	57.61
8	3.46	50	21.65	92	39.85	134	58.04
9	3.89	51	22.09	93	40.28	135	58.48
10	4.33	52	22.52	94	40.72	136	58.91
11	4.76	53	22.95	95	41.15	137	59.34
12	5.20	54	23.39	96	41.58	138	59.77
13	5.63	55	23.82	97	42.01	139	60.21
14	6.06	56	24.26	98	42.45	140	60.64
15	6.49	57	24.69	99	42.88	141	61.07
16	6.93	58	25.12	100	43.31	142	61.51
17	7.36	59	25.55	101	43.75	143	61.94
18	7.79	60	25.99	102	44.18	144	62.37
19	8.22	61	26.42	103	44.61	145	62.81
20	8.66	62	26.85	104	45.05	146	63.24
21	9.09	63	27.29	105	45.48	147	63.67
22	9.53	64	27.72	106	45.91	148	64.10
23	9.96	65	28.15	107	46.34	149	64.54
24	10.39	66	28.58	108	46.78	150	64.97
25	10.82	67	29.02	109	47.21	151	65.40
26	11.26	68	29.45	110	47.64	152	65.84
27	11.69	69	29.88	111	48.08	153	66.27
28	12.12	70	30.32	112	48.51	154	66.70
29	12.55	71	30.75	113	48.94	155	67.14
30	12.99	72	31.18	114	49.38	156	67.57
31	13.42	73	31.62	115	49.81	157	68.00
32	13.86	74	32.05	116	50.24	158	68.43
33	14.29	75	32.48	117	50.68	159	68.87
34	14.72	76	32.92	118	51.11	160	69.31
35	15.16	77	33.35	119	51.54	161	69.74
36	15.59	78	33.78	120	51.98	162	70.17
37	16.02	79	34.21	121	52.41	163	70.61
38	16.45	80	34.65	122	52.84	164	71.04
39	16.89	81	35.08	123	53.28	165	71.47
40	17.32	82	35.52	124	53.71	166	71.91
41	17.75	83	35.95	125	54.15	167	72.34
42	18.19	84	36.39	126	54.58	168	72.77

TABLE 44 (Continued). — FEET HEAD AND EQUIVALENT PRESSURE IN POUNDS PER SQUARE INCH.

Ft. head.	Equiv. press. in. pounds.	Ft. head.	Equiv. press. in. pounds.	Ft. head.	Equiv. press. in. pounds.	Ft. head.	Equiv. press. in. pounds.
169	73.20	206	89.23	243	105.26	280	121.29
170	73.64	207	89.68	244	105.69	281	121.73
171	74.07	208	90.10	245	106.13	282	122.15
172	74.50	209	90.53	246	106.56	283	122.59
173	74.94	210	90.96	247	106.99	284	123.02
174	75.37	211	91.39	248	107.43	285	123.45
175	75.80	212	91.83	249	107.86	286	123.89
176	76.23	213	92.26	250	108.29	287	124.32
177	76.67	214	92.69	251	108.73	288	124.75
178	77.10	215	93.13	252	109.16	289	125.18
179	77.53	216	93.56	253	109.59	290	125.62
180	77.97	217	93.99	254	110.03	291	126.05
181	78.40	218	94.43	255	110.46	292	126.48
182	78.84	219	94.86	256	110.89	293	126.92
183	79.27	220	95.30	257	111.32	294	127.35
184	79.70	221	95.73	258	111.76	295	127.78
185	80.14	222	96.16	259	112.19	296	128.22
186	80.57	223	96.60	260	112.62	297	128.65
187	81.00	224	97.03	261	113.06	298	129.08
188	81.43	225	97.46	262	113.49	299	129.51
189	81.87	226	97.90	263	113.92	300	129.95
190	82.30	227	98.33	264	114.36	310	134.23
191	82.73	228	98.76	265	114.79	320	138.62
192	83.17	229	99.20	266	115.22	330	142.95
193	83.60	230	99.63	267	115.66	340	147.28
194	84.03	231	100.00	268	116.09	350	151.61
195	84.47	232	100.49	269	116.52	360	155.94
196	84.90	233	100.93	270	116.96	370	160.27
197	85.33	234	101.36	271	117.39	380	164.61
198	85.76	235	101.79	272	117.82	390	168.94
199	86.20	236	102.23	273	118.26	400	173.27
200	86.63	237	102.66	274	118.69	500	216.58
201	87.07	238	103.09	275	119.12	600	259.90
202	87.50	239	103.53	276	119.56	700	303.22
203	87.93	240	103.96	277	119.99	800	346.54
204	88.36	241	104.39	278	120.42	900	389.86
205	88.80	242	104.83	279	120.85	1000	435.18

TABLE 45. — FRICTION OF WATER IN PIPES.

Pressure in pounds per square inch to be added for each 100 feet of clean iron pipe.

Gals. per minute delivered.	Pipe sizes.															
	$\frac{3}{4}$	1	1 $\frac{1}{4}$	1 $\frac{1}{2}$	2	2 $\frac{1}{2}$	3	3 $\frac{1}{2}$	4	5	6	7	8	9	10	12
5	3.3	.84	.31	.12	.04	.02
10	13.0	3.16	1.05	.47	.12	.04	.02
15	28.7	6.98	2.38	.97	.25	.08	.04	.02
20	50.4	12.3	4.07	1.66	.42	.14	.06	.03
25	78.0	19.0	6.40	2.62	.62	.21	.10	.04	.02
30	27.5	9.15	3.75	.91	.30	.13	.06	.03
35	37.0	12.4	5.05	1.22	.40	.17	.09	.05	.02
40	48.0	16.1	6.52	1.60	.53	.23	.11	.06	.02
45	20.2	8.15	1.99	.66	.28	.14	.07	.03
50	24.9	10.0	2.44	.81	.35	.17	.09	.04
60	36.0	14.0	3.50	1.17	.50	.24	.13	.05	.02
70	48.0	20.0	4.80	1.50	.60	.38	.19	.07	.03
75	56.1	22.4	5.32	1.80	.74
80	64.0	25.0	6.30	2.00	.90	.41	.23	.08	.03
90	80.0	32.0	7.80	2.58	1.10	.54	.26	.09	.04
100	39.0	9.46	3.20	1.31	.64	.33	.12	.05	.02
125	14.9	4.89	1.99	.96	.49	.17	.07	.03
150	21.2	7.00	2.85	1.35	.69	.25	.10	.04
175	28.1	9.46	3.85	1.82	.93	.34	.13	.05
200	37.5	12.47	5.02	2.38	1.22	.42	.17	.07
250	19.66	7.76	3.70	1.89	.65	.26	.12	.07	.04	.03	.01
300	28.06	11.2	5.04	2.66	.93	.37	.17	.09	.05	.04
350	15.2	7.10	3.65	1.26	.50	.23	.12	.07	.05	.02
400	19.5	9.25	4.73	1.61	.65	.30	.16	.09	.06
450	25.0	11.70	6.01	2.00	.81	.37	.20	.11	.07	.03
500	30.8	14.5	7.43	2.40	.96	.45	.25	.14	.09	.04
750	2.21	1.03	.53	.30	.18	.08
1000	3.88	1.80	.94	.53	.32	.13
1250	6.00	2.85	1.46	.82	.49	.20
1500	8.60	4.08	2.09	1.17	.70	.29

Table is based on Ellis' and Howland's experiments. To find "friction head" in feet multiply figures by 2.3.

TABLE 45a. — FRICTION OF WATER IN ELBOWS.
Pressure in pounds per square inch to be added for each elbow.

Gals. per minute delivered.	Pipe sizes.															
	¾	1	1¼	1½	2	2½	3	3½	4	5	6	7	8	9	10	12
5	.07	.027	.008	.005	.002
10	.28	.094	.031	.018	.006	.003
15	.63	.212	.069	.04	.014	.005
20	1.12	.376	.123	.069	.025	.012	.005
25	1.74	.585	.194	.108	.038	.02	.008
30845	.278	.157	.055	.028	.011
35	1.15	.380	.215	.076	.037	.015	.009
40	1.50	.495	.278	.098	.049	.02	.011	.007
45	1.90	.626	.352	.125	.062	.026	.015	.009
5077	.43	.153	.08	.032	.017	.01
60	3.38	1.11	.62	.22	.112	.044	.026	.015	.006	.003
70	4.60	1.52	.86	.304	.148	.06	.035	.021	.009	.004	.002
75	5.30	1.74	.98	.35	.172	.072	.04	.024	.01	.005	.003
80	6.00	1.98	1.11	.392	.196	.08	.044	.027	.012	.005	.003
90	7.60	2.50	1.41	.50	.248	.104	.06	.035	.014	.007	.004
100	3.08	1.72	.612	.32	.128	.068	.043	.017	.008	.005	.003	.002
125	2.72	.97	.48	.20	.112	.067	.027	.013	.007	.004	.003	.002
150	3.92	1.39	.685	.286	.16	.096	.039	.019	.01	.006	.004	.003	.001
175	5.32	1.90	.935	.390	.218	.132	.053	.026	.014	.009	.005	.004	.002
200	6.88	2.44	1.28	.512	.272	.172	.068	.032	.02	.011	.007	.005	.002
250	3.86	1.91	.80	.446	.268	.109	.052	.029	.017	.011	.007	.004
300	5.56	2.74	1.14	.64	.384	.156	.076	.042	.025	.016	.01	.005
350	3.77	1.58	.88	.530	.215	.103	.057	.034	.022	.014	.007
400	5.12	2.05	1.09	.688	.272	.128	.08	.044	.028	.018	.009
450	6.20	2.58	1.45	.870	.352	.170	.094	.057	.036	.023	.011
500	7.64	3.20	1.78	1.07	.436	.208	.116	.068	.044	.028	.016
750	2.42	.970	.470	.260	.156	.10	.063	.031
1000	4.28	1.74	.832	.464	.272	.176	.112	.064
1250	6.70	2.71	1.31	.728	.435	.276	.175	.086
1500	9.68	3.88	1.88	.84	.624	.40	.252	.124

Table is based on Weisbach's formula for very short bends, or with a radius equal to the radius of the pipe. To find "friction head" in feet multiply figures by 2.3.

Theoretical Horsepower.

Theoretical horsepower necessary to raise water any height

$$= \frac{\text{gallons per minute} \times 8.33 \times \text{height in feet}}{33000}$$

= horsepower per minute.

8.33 = weight of a gallon of water.
33000 = number of foot-pounds per minute in one horsepower.

TABLE 46. — THEORETICAL HORSEPOWER TO RAISE WATER TO DIFFERENT HEIGHTS.

U. S. gallons per minute.	U. S. gallons per hour.	Height in feet.																
		20	25	30	35	40	45	50	60	75	90	100	125	150	175	200	250	300
20	1,200	.100	.125	.150	.175	.20	.22	.25	.30	.37	.45	.50	.62	.75	.87	1.00	1.25	1.50
25	1,500	.125	.156	.187	.219	.25	.28	.31	.37	.47	.56	.62	.78	.94	1.09	1.26	1.56	1.87
30	1,800	.150	.187	.225	.262	.30	.34	.37	.45	.56	.67	.75	.94	1.12	1.31	1.50	1.87	2.25
35	2,100	.175	.219	.262	.306	.35	.39	.44	.52	.66	.79	.87	1.08	1.31	1.53	1.75	2.19	2.62
40	2,400	.200	.250	.300	.350	.40	.45	.50	.60	.75	.90	1.00	1.25	1.50	1.75	2.00	2.50	3.00
45	2,700	.225	.281	.337	.394	.45	.51	.56	.67	.84	1.01	1.12	1.41	1.69	1.97	2.25	2.81	3.37
50	3,000	.250	.312	.375	.437	.50	.56	.62	.75	.94	1.12	1.25	1.56	1.87	2.19	2.50	3.12	3.75
60	3,600	.300	.375	.450	.525	.60	.67	.75	.90	1.12	1.35	1.50	1.87	2.25	2.62	3.00	3.75	4.50
75	4,500	.375	.469	.562	.656	.75	.84	.94	1.12	1.40	1.69	1.87	2.34	2.81	3.28	3.75	4.69	5.62
90	5,400	.450	.562	.675	.787	.90	1.01	1.12	1.35	1.68	2.02	2.25	2.81	3.37	3.94	4.5	5.62	6.75
100	6,000	.500	.625	.750	.875	1.00	1.12	1.25	1.50	1.87	2.25	2.50	3.12	3.75	4.37	5.00	6.25	7.50
125	7,500	.625	.781	.937	1.094	1.25	1.41	1.56	1.87	2.34	2.81	3.16	3.91	4.69	5.47	6.25	7.81	9.37
150	9,000	.750	.937	1.125	1.312	1.50	1.69	1.87	2.25	2.81	3.37	3.75	4.69	5.62	6.56	7.5	9.37	11.25
175	10,500	.875	1.093	1.312	1.531	1.75	1.97	2.19	2.62	3.28	3.94	4.07	5.47	6.56	7.66	8.75	10.94	13.12
200	12,000	1.00	1.25	1.50	1.75	2.00	2.25	2.50	3.00	3.75	4.50	5.00	6.25	7.50	8.75	10.00	12.50	15.00
250	15,000	1.25	1.562	1.875	2.187	2.50	2.81	3.12	3.75	4.69	5.62	6.25	7.81	9.37	10.94	12.50	15.72	18.75
300	18,000	1.50	1.875	2.25	2.625	3.00	3.37	3.75	4.50	5.62	6.75	7.50	9.57	11.25	13.12	15.00	18.75	22.50
350	21,000	1.75	2.187	2.625	3.062	3.50	3.94	4.37	5.25	6.56	7.87	8.75	10.94	13.12	15.31	17.50	21.87	26.25
400	24,000	2.00	2.5	3.00	3.50	4.00	4.50	5.00	6.00	7.50	9.00	10.00	12.50	15.00	17.50	20.00	25.00	30.00
500	30,000	2.25	3.125	3.75	4.375	5.00	5.62	6.25	7.50	9.37	11.25	12.5	15.62	18.75	21.87	25.00	31.25	37.50

Engine Horsepower.

$$\text{Horsepower} = \frac{P \times L \times A \times N}{33000}$$

P = average effective pressure in pounds per square inch.

L = twice the length of piston stroke in feet.

A = area of piston in square inches.

N = the number of revolutions of the crank shaft per minute.

TABLE 47. — AVERAGE STEAM PRESSURE ON PISTON, IN POUNDS PER SQUARE INCH.

Aver. press. throughout the piston stroke. (Initial press.= 1.)	.966	.937	.919	.846	.743	.699	.596	.385
Grade of expansion of steam.	1½	1½	1⅔	2	2⅔	3	4	8
Steam cut-off.	¾	⅔	⅝	½	⅜	⅓	¼	⅛
Initial steam press., lbs. per sq. in.								
25.....	24.1	23.4	22.9	21.1	18.5	17.4	19.9	9.6
30.....	28.9	28.1	27.5	25.3	22.2	20.9	17.8	11.5
35.....	33.7	32.8	32.1	29.6	25.9	24.4	20.8	13.4
40.....	38.6	37.4	36.7	33.8	28.9	27.9	23.8	15.3
45.....	43.4	42.1	41.2	38.0	32.6	31.4	26.8	17.3
50.....	48.2	46.8	45.9	42.3	37.1	35.0	29.8	19.2
55.....	53.0	51.3	50.5	46.6	40.8	38.4	32.8	21.2
60.....	57.8	56.0	55.1	50.8	44.5	41.9	35.8	23.1
65.....	62.8	60.7	59.7	55.0	48.2	45.4	38.8	24.9
70.....	67.5	65.3	64.3	59.2	52.4	48.9	41.6	26.7
75.....	72.3	70.0	68.9	63.5	56.1	52.4	44.7	28.6
80.....	77.1	75.7	73.5	67.7	59.3	53.9	47.7	30.8
85.....	81.9	80.3	78.1	72.0	63.0	59.4	50.7	32.7
90.....	86.7	84.0	82.7	76.2	66.8	62.9	53.7	34.6
95.....	91.5	88.7	87.3	80.4	70.4	66.4	56.7	36.6
100.....	96.4	93.3	91.9	84.5	74.2	69.9	59.6	38.5
105.....	101.2	98.0	96.5	88.9	77.9	73.4	62.6	40.4
110.....	106.0	101.7	101.0	93.1	81.6	76.9	66.6	42.3
115.....	110.8	106.3	105.6	97.4	85.2	80.4	69.6	44.2
120.....	115.6	112.0	110.2	101.6	89.0	83.9	71.6	46.2
125.....	120.5	115.7	114.8	105.8	102.8	87.4	74.6	48.1

Example. — What horsepower will a steam engine 8-inch bore and 12-inch stroke develop at 100 revolutions of the crank shaft per minute, cutting off one-third stroke and having an initial pressure 100 pounds?

P, 100 pounds initial pressure one-third stroke, from table = 69.9, less say 14.9 for back pressure, = 55 pounds; *L*, twice stroke, = 12" × 2 = 2 feet; *A*, area 8-inch piston, = 50.26; *N*, 100; hence horsepower of engine

$$= \frac{55 \times 2 \times 50.26 \times 100}{33000} = 16.8.$$

General Water Information.

TABLE 48. — EQUIVALENTS OF WATER BY WEIGHT AND MEASURE.

Water.	U. S. gallons.	Imperial gallons.	Cubic feet.	Cubic inches.	Pounds.
U. S. gallon.....	1.00	.833	.133	231	8.33
Imperial gallon...	1.2	1.00	.16	277.274	10.00
Cubic foot.....	7.48	6.23	1.00	1728	62.35
Cubic inch.....	.0043	.0036	.00058	1.00	.036
One pound.....	.12	.10	.16	27.72	1.00

A miner's inch of water is approximately equal to a supply of 12 U. S. gallons per minute.

Area of Pipe. — To find the area of a required pipe, the volume and velocity being given, multiply the number of cubic feet of water by 144 and divide the product by the velocity in feet per minute.

Velocity. — To find the velocity in feet per minute to discharge a stated number of gallons per minute divide the amount of discharge in gallons per minute by the number of gallons in one lineal foot, or the number of gallons per minute by 144, and divide by the area of pipe in inches.

TABLE 48a.—NUMBER OF U. S. GALLONS IN ONE LINEAL FOOT OF PIPE.

Inside diameter of pipe.	1 in.	2 in.	2½ in.	3 in.	4 in.
Cubic foot.....	.0055	.0218	.0341	.0491	.0873
Gallons per lineal foot....	.0408	.1632	.2550	.3673	.6528
Area, square inches.....	.785	3.14	4.9	7.06	12.56
	6 in.	8 in.	9 in.	10 in.	12 in.
Cubic foot.....	.1963	.3490	.4418	.5455	.7854
Gallons per lineal foot ...	1.469	2.611	3.305	4.081	5.875
Area, square inches.....	28.27	50.26	63.61	78.54	113.09

Depth of Suction. — The mean pressure of the atmosphere is estimated at 14.7 pounds per square inch. With a perfect vacuum at sea level it will therefore sustain a column of mercury 29.9 inches, or a column of water 33.9 feet high. This is the theoretical height that a perfect pump would draw water. Owing to air in the water, valve leakage, etc., the actual height in practice seldom exceeds 20 feet, and the velocity through the suction pipe should not exceed 200 feet per minute, as the resistance of suction will be too great. To obviate this tendency the suction pipe is usually one or two sizes larger than the delivery or discharge pipe.

Pump House.

When the source of water supply renders it necessary a small frame building is erected to house in the pump and boiler, similar to Fig. 89.

Approximate cost complete. —

Cedar sill foundation.....	\$500 to \$700
Masonry foundation.....	650 to 850

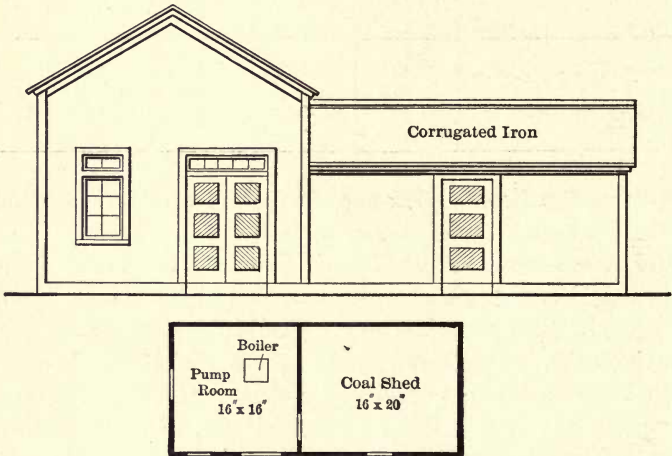

Fig. 89. Pump House.

Construction. — Lumber, spruce, hemlock or pine; mouldings, doors, windows, frames, etc., stock patterns.

Boiler house 16' x 16', coal shed 16' x 20'; cedar sill or masonry foundation; frames 2" x 4" studs at 2-foot centers; wall plates and runners 4" x 4"; rafters and ties 2" x 6" at 2-foot centers; frame covered with 7/8-inch rough boards finished with drop siding or clapboards with building paper between; roof covered with 7/8-inch rough boards and corrugated iron.

Boiler room floor, 9 inches cinders well rammed; coal shed floor, 2-inch plank on 3-inch cedar sleepers about 4-foot centers; studs to be braced to cross ties with 2" x 4" braces, and the inside lined with 2-inch plank 5 feet 6 inches high.

When a gasoline or oil pump is used the coal shed can be dispensed with and the cost reduced about 40 per cent.

Tanks.

At way stations the water tank is usually placed on the right of way convenient to the track so that locomotives can take water direct; in yards the tank is placed about the center of distribution when possible, arranged so that it will not interfere with future extensions. In large yards duplicate tanks are provided, and they are sometimes raised high enough to provide sufficient pressure for fire purposes. Convenient water service is obtained by the use of standpipes fed from the tank.

Construction. — A diagram of the ordinary tank structure is shown on Fig. 90a, and consists of stone or concrete foundations, wood, steel or cast-iron posts, and wood or steel tank with frost-proof roof; the floor of the tank is generally 3-inch plank on wood or steel joists, or reinforced concrete. Frost boxing around the supply pipe is required to protect it from freezing, and when climate conditions are severe the inner or outer posts are boarded in, or the structure is enclosed by a separate house as per Fig. 90c. The space enclosed is sometimes used as a pump and boiler room when convenient.

Tank. — The common wood tank is made of pine, cypress, fir, cedar, or other suitable timber; the staves and bottom are machine shaped, so as to fit tight when erected, and are assembled with dowel pins; the tank walls are held by iron bands on the outside, fastened with lugs and bolts, arranged so that they can be tightened up when necessary. The steel tank is made of boiler plates riveted together and calked.

The sizes vary in capacity from 10,000 to 100,000 gallons or more; the general standard is from 40,000 to 50,000 gallons.

Fixtures. — The fixtures consist of a tank valve and outlet pipe with elbow, to which is attached a sway pipe with holdfasts, pull chain, hangers, counterweights, sheaves, eyebolts, guide pipes, valve rod, indicator, pulley, chains, sheaves, and float.

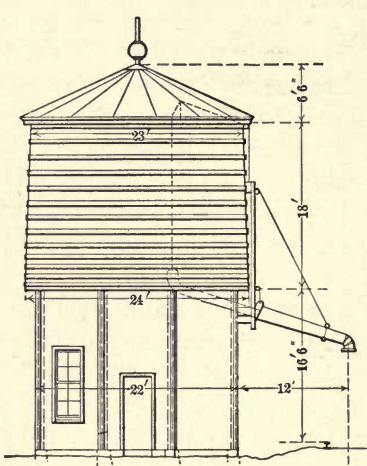

Fig. 90a.

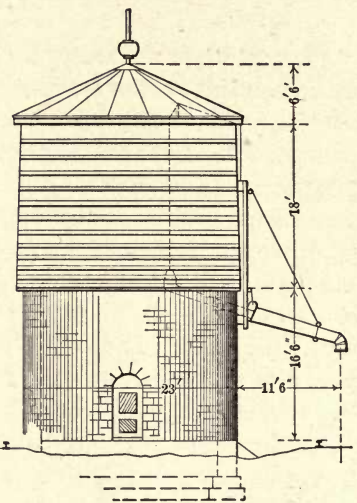

Fig. 90b.

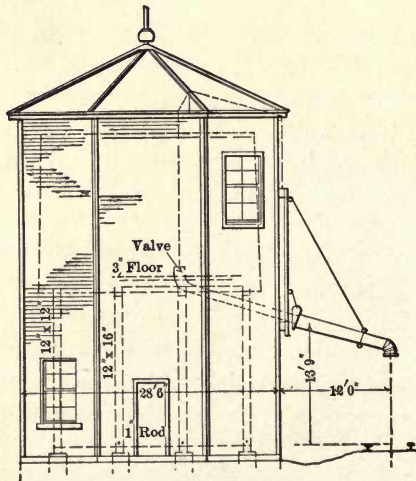

Fig. 90c.

Water Tanks.

TABLE 49. — APPROXIMATE COST OF WATER TANKS COMPLETE; FOR TOWERS 20 FEET HIGH FROM RAIL TO TANK FLOOR.

Approximate capacity in gallons.	Height tank staves.	Diameter tank.	Enclosed tanks, wood. Fig. 90c.	Semi-enclosed, wood. Fig. 90a.	Semi-enclosed, masonry. Fig. 90b.
	Ft.	Ft.			
10,000	10	14½	\$1000-1200
20,000	12	18	1200-1500
30,000	14	21	\$1800-2100	1500-1800	\$1500-1700
40,000	16	22	2300-2800	1800-2200	2200-2600
50,000	16	25	3300-3800	2600-3000	3000-3500
60,000	16	27	4300-4800	3500-3800	3800-4300

NOTE. — In the above cost no allowance is made for supply pipes, waste and drainage; these generally are included in the estimate of water supply.

For cost of pump, boilers, etc., see page 178.

A brief description of a 40,000-gallon enclosed water tank (Fig. 90c) is as follows:—

Foundations. — Masonry or concrete piers under each post, 1 foot 6 inches square at top and 4 feet square at bottom, depth 5 feet. The piers of the outer posts are extended to catch the foundation sills of the housing.

Posts. — Outer 12" × 12", inner 12" × 16" upright, well braced and tied with rods, 12" × 12" framing and 12" × 16" cross beams, with oak corbels at top of posts and 4" × 12" joists over, covered with 3-inch plank.

Tub. — 16-foot staves, bottom outside diameter 24 feet, top outside diameter 23 feet, cedar staves 3 inches thick with iron bands at varying intervals on the outside.

Housing. — The housing consists in building an ordinary frame structure around the tank, supported on cedar sills resting on the foundation piers. The walls are octagon-shaped, set back to get 18 inches clear at the tub, studs 2" × 6" at 2-foot centers, doubled at corners, with 4" × 6" wall plates, and 2" × 6" stiffeners, and double boarding on the outside with building paper between. The roof is made of 2" × 6" rafters and ties, covered on the outside with T. and G. boarding and shingles or ready roofing on top. The frame is held to the main posts of the tank with 2" × 6" braces. The mechanism has already been described under fixtures.

Approximate cost of the above 40,000-gallon enclosed tank. —

Quantities.	Material.	Labor.	Total unit.	Cost.
94 cubic yards excavation.....			\$0.50	\$47.00
50 cubic yards masonry.....	\$3.50	\$4.50	8.00	400.00
Cinder floor.....	14.00	14.00	28.00
20,000 feet board measure housing, per thousand.....	18.00	17.00	35.00	700.00
13,000 feet board measure tank, per thousand.....	28.00	22.00	50.00	650.00
Windows, doors, etc.....	70.00	34.00	104.00
9 squares shingles, per square (100 square feet).....	2.50	2.50	5.00	45.00
Hardware and mechanism.....	171.00	200.00	371.00
Painting and glazing.....	35.00	40.00	75.00
				\$2420.00
Supervision and contingencies 10%.....				242.00
Total.....				\$2662.00

Standpipes. (Fig. 91.)

The ordinary track water column or standpipe for railroad purposes is principally used to duplicate the water service from a main supply, for the convenience of locomotives.

As it takes up little room and is arranged to swing clear of the tracks when not in use, it is not considered a serious obstruction.

They are used very extensively at stations, yards, and other places where convenient for quick service, and are generally located so that one standpipe will serve two tracks, the distance being made wider for this purpose. When tracks are parallel, the minimum distance is 16-foot centers.

A pipe line from the service water tank the full size of the standpipe is run connecting the two as direct as possible, so as to render a high velocity supply; sometimes the connection is made with the city or town's high pressure mains and charged by meter.

The standpipes in general use are 6, 8, 10, and 12 inches, weighing from 2500 to 5000 pounds each.

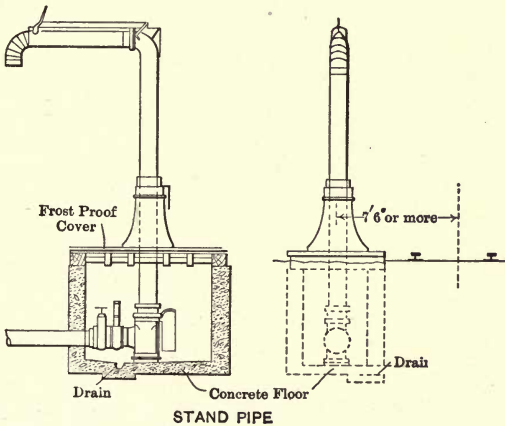

Fig. 91.

Approximate cost when the supply line does not exceed 50 feet.—

	Wood chamber.	Concrete chamber.
6-inch standpipe complete in place	\$300 to \$400	\$400 to \$450
8-inch standpipe complete in place	450 to 550	550 to 650
10-inch standpipe complete in place	500 to 600	600 to 700
12-inch standpipe complete in place	550 to 650	650 to 750

Construction. — The standpipes are made in a variety of designs and usually consist of a cast base, wrought-iron flanged upright, steel spout with splash nozzle, including valves and operating mechanism, as per Fig. 91.

The supply is controlled by levers convenient for ready use.

The valve is placed in a wood or concrete box about 4 feet wide, 8 feet long, and 7 feet deep, with wood or concrete floor dished to drain; a frost-proof cover is placed over the pit about top of rail level, on which the cast base of the pipe is secured; a manhole is also inserted for inspection purposes, and a suitable drain is necessary to carry off the waste and leakage.

APPROXIMATE ESTIMATE FOR SUPPLY PIPE AND STANDPIPE. —
SUPPLY PIPE 140 FEET LONG.

Supply pipe:

Excavation for supply pipe, 110 cubic yards at 75 cts.	\$ 82.50	
C. I. pipe, 10-inch supply, 5.26 tons at \$35.....	184.10	
Lead for joints, 168 pounds at 8 cts.....	13.44	
Laying pipe, 140 lineal feet at 17 cts.....	23.80	
Connections.....	10.00	
		\$313.84

Standpipe:

1 10-inch standpipe erected.....	\$350.00	
Excavation for pit, 10 cubic yards at 75 cts.....	7.50	
Concrete pit.....	100.00	
		57.50

Drain 5 feet deep:

Excavation 164 cubic yards at 75 cts.....	\$125.00	
210 lineal feet 4-inch tile pipe laid, at 16 cts.....	33.60	
Bell trap bends and connections.....	13.40	
		170.00

		\$941.34
Supervision and contingencies 10%.....		94.66

Total.....		\$1036.00
------------	--	-----------

Dams.

Dams for impounding water for gravity service average from 6 to 12 feet in height; consisting usually of an earth embankment or such material as can be had conveniently near the location, or wood crib, or stone or concrete retaining wall.

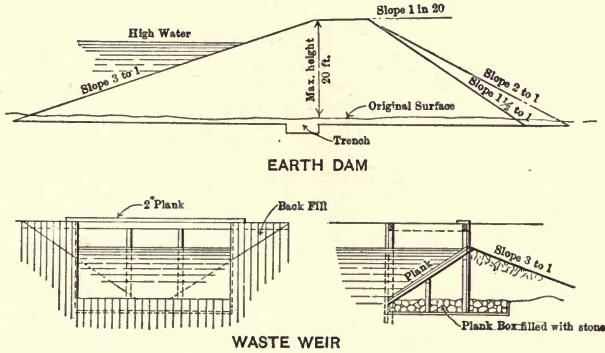

Fig. 92.

Fig. 92 represents the general cross section for earth dam; with ordinary material it is recommended that the upstream slope should not be steeper than 1 to 3, the rear slope $1\frac{1}{2}$ to 1, preferably 1 to 1, top width not less than 6 feet for a height of 10 feet or less, 8 feet wide from 10 to 15 feet high, and 10 feet wide for 15 to 20 feet high.

The foundation should be on firm ground, with all sod and perishable matter removed over the entire area of the foundation for a depth of at least 6 inches, to prevent disintegration and possible leakage.

When the height exceeds 10 feet, an intercepting or bond trench 2 feet deep, from 6 to 12 feet wide, should be made running the full length.

The inner slope should be protected with a thick layer of hard material, and when subject to wave action a further layer of heavy rock should be provided; the rear slope is best protected by sod.

The waste way if possible should be located at a natural gap. If placed close to the dam, care must be taken to prevent the spill from endangering the dam from washing, saturation, or erosion, by

building aprons and wings to prevent the water from passing around or under the dam. For safety, waste water should always be discharged at a distance from the dam.

Top of levee should be at least 6 feet wide and level with top of dam, with slopes or waste side not steeper than 1 to 3, riprapped when possible. Difference in elevation between top of dam and bottom of waste way should not be less than 4 feet, with slope of dam side at angle of repose.

A deep fall waste should have checks so as to form a series of smaller falls.

The waste way may be constructed of timber as shown in sketch, though permanent material is more desirable.

Crib and Masonry Dam. — When the location is convenient and only a gap or small length of dam is necessary a masonry or concrete wall or crib as illustrated in Figs. 93 and 94 is often used.

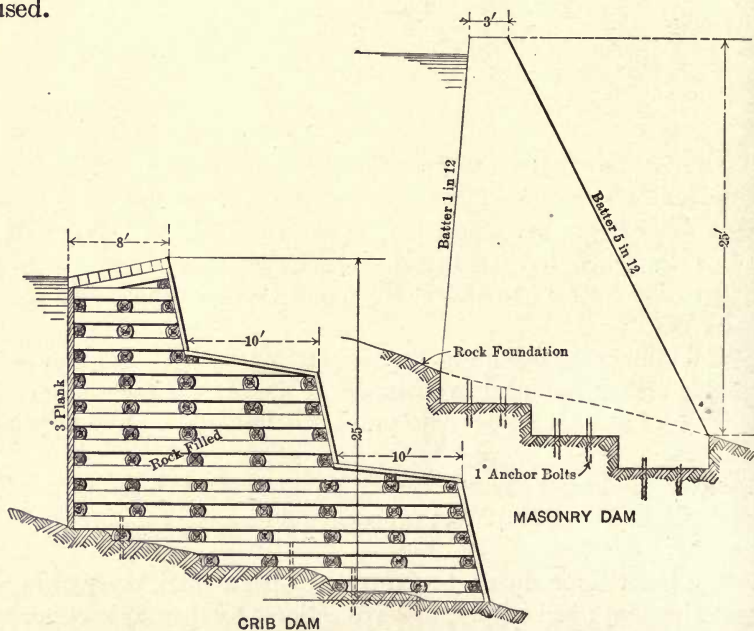

Fig. 93.

Fig. 94.

With the masonry dam it would be necessary to have a waste way at some natural point around the storage reservoir or a

sluice with gate valves to let out the over surplus water in time of floods or severe storms.

The crib dam is built with three offsets so as to form a spill way in itself.

The approximate cost of dams will vary greatly, depending on local conditions.

Approximate cost. — Earth dams 12 feet high, per lineal foot, \$5 to \$15. Wood and crib 25 feet high, per lineal foot, \$40 to \$60. Stone dam 25 feet high, per lineal foot, \$80 to \$150.

APPROXIMATE ESTIMATE GRAVITY WATER SUPPLY PIPE LINE 2500 FEET LONG (300 FEET IN DOUBLE WOOD BOX).

Crib dam:

3000 lineal feet cedar logs at 15 cts.....	\$450.00	
6000 feet board measure timber at \$50.....	300.00	
200 cubic yards boulder fill at 50 cts.....	100.00	
Waste channel and fixing up gully for overflow....	150.00	
	<hr/>	\$1000.00

Pipe line:

1800 cubic yards excavation boulders and rock, \$2.00	\$3600.00	
1500 cubic yards earth, 75 cts.....	1125.00	
25 tons C. I. 4-inch pipe, \$35.00.....	875.00	
16 tons W. I. pipe, \$38.00.....	61.00	
1500 pounds lead for joints, 8 cts.....	120.00	
Hauling and distributing pipes.....	125.00	
Laying joints.....	125.00	
Valves, bends, etc.....	100.00	
	<hr/>	6131.00

Boxing pipe account of precipice 300 feet:

10,600 feet board measure timber, per thousand \$50.00	\$530.00	
4200 square feet tar paper, 10 cts.....	42.00	
Trestle support to pipe when boxed.....	100.00	
	<hr/>	672.00

Supervision and contingencies.....

\$7823.00
777.00

Total.....

\$8600.00

Track Tanks.

Track tanks are used to a limited extent, and usually consist of steel troughs placed directly on the ties, to hold the water so that locomotives can scoop up a supply while in motion, and are used for passenger and freight service to expedite train movement on congested districts.

A comprehensive article in detail is given of this type of structure in the *Railroad Gazette*, March 13, 1908, by H. H. Ross.

The tanks must be located where the supply of water is abundant and of good quality; 15 to 50 per cent of the water is wasted by being forced out over the sides and ends by the engine scoops. The speed for satisfactory service is from 25 to 30 miles per hour, and the tracks are graded at the approaches to enable the necessary speed to be made, and for this reason track tanks should be away from any structures, crossings, yards, etc., and be well drained so that the water that gets into the bank is carried away quickly. This is done by stone-filled trenches and tile between tracks, the ballast being covered with large flat stones to hold the ballast and shed the water.

Approximate cost. — A double-track installation will cost \$15,000 to \$30,000 exclusive of grading, track work, and drainage. The maintenance averages probably about 8 per cent of the cost.

Construction. — The ties supporting the trough should be of white oak 8" \times 10" \times 8' 6" long, and track thoroughly surfaced and filled in with stone ballast and same quality of ballast continued for at least 1000 feet beyond the troughs on the trailing ends, and all ties tie plated.

Water is usually supplied from elevated tanks, with a large-sized main reduced for the different inlets; 1½ to 2 minutes are required to refill trough after an engine has scooped, and the filling is done with automatic valves.

Trough recommended, 28 inches wide, 7½ inches deep, and 2000 feet long, to give 5000 to 6000 gallons in a run. When track tanks are used in cold climates, it is necessary to heat the water to keep it from freezing, which is done by steam blowing, or by circulating by means of a pump or an injector.

CHAPTER VII.

RAILROAD SHOPS.

THE cost of slow-burning mill construction shops, usually built to conform with the underwriters' requirements in fire resistance, is given in Table 50, and the construction generally is as follows.

Foundations. — Masonry or concrete foundation walls, from floor to five feet below ground, or to such depths as may be necessary to secure a good foundation, finished with a 12-inch chamfered water table on top.

Walls. — Exterior walls built of common brick, faced with second quality pressed brick; door and window sills, bush hammered stone or concrete. Walls are self-supporting, 24 to 16 inches thick at the bottom, and not less than 12 inches thick at the top, with pilasters at every bay, well projected inside when carrying trusses. The gable walls also are stiffened with pilasters between doors or windows.

Floors. — Floor foundation 12 inches cinders in which 4"×6" sleepers are embedded 4 feet apart and covered with 3-inch plank, for most of the buildings.

Roofs. — Flat roof construction sloping 1 in 12 from the central axis, and covered with tar and gravel on 3-inch plank.

Lights. — The buildings are lighted by large windows occupying about 50 per cent of the wall area, and roof skylight monitors about 12 feet wide, with double pitched roofs glazed with rough glass. The skylights occupy about 25 per cent of the roof area, and have 24-inch ventilators in each skylight.

Office, etc. — Small lean-to's are placed on the side of the buildings for lavatories, fan rooms, and shop offices.

Heat and Fire Protection. — The buildings are equipped with the sprinkler system of fire protection, and heated by the hot-air method or exhaust steam vacuum system.

Electric Light. — Arc and incandescent lamps, open wire or pipe conduit.

Equipment. — The equipment is given in percentage of total cost in Table 50 and in detail in Tables 51, 52, and 53.

TABLE 50.—APPROXIMATE COST DATA RAILROAD SHOPS, FOUNDATIONS 5 FEET BELOW GROUND.

Shop name.	Average width, length, and height.	Contents.		Cost of building only.			Equipment add per cent of total cost.*
				Total.	Sq. ft.	Cu. ft.	
	Ft.	Sq. ft.	Cu. ft.			Cents.	Percent
Blacksmith...	146×434 and 130×158×32	83,600	2,697,000	\$101,000	\$1.20	3½	30
Cabinet.....	62×580×27	36,900	954,700	53,000	1.43	5½	25
Car machine..	130×288×27	38,400	1,066,600	44,200	1.15	4½	25
Car truck.....	82×434×20	36,800	763,600	38,600	1.05	5	20
Dry kiln, soft wood.....	70×85×16	6,900	96,500	7,400	1.05	7½	90
Dry kiln, hard wood.....	40×85×16	3,700	51,700	4,200	1.11	8	90
Foundry, gray iron.....	122×342×30	42,700	1,354,700	80,300	1.90	6	40
Freight car...	107×540×30	59,500	1,829,900	76,700	1.28	4½	25
Frog and switch.....	102×264×22	30,300	674,000	29,700	.99	4½	30
Locomotive, boiler, erecting and machine.....	163×168×50	191,300	9,520,800	497,200	2.60	5½	10
Offices.....	56×80×54	4,500	241,900	27,700	6.20	12	35
Passenger car erection....	100×672×24	69,400	1,752,700	69,000	1.00	3½	35
Passenger car paint.....	100×672×24	69,400	1,752,700	75,800	1.07	4½	35
Pattern.....	50×82×26	4,100	135,500	7,400	1.80	5½	25
Pattern stores	50×150×30	7,500	247,500	17,300	2.31	7½	5
Planing mill..	50×150×30	63,300	1,835,300	64,400	1.33	4	30
Power house..	104×160×39½	17,200	616,400	84,700	4.92	1½	500
Stores general	85×594×33	50,500	1,653,500	88,100	1.75	5½	20
Wheel foundry	107×187×24	24,300	649,800	46,700	1.93	7½	100

* Equipment includes heating, plumbing, fire protection, cranes, elevators, electric wires and lighting.

TABLE 51. — DATA OF MISCELLANEOUS POWER HOUSE EQUIPMENT.

Equipment.	Approximate cost in place.	Approximate cost per unit.
Boilers and stokers.....	\$88,500	\$27.50 per B.H.P.
Generators.....	50,600	22.48 per Kw.
Engines.....	68,000	20.88 per H.P.
Compressors.....	15,400	
Economizers.....	10,500	
Induced draft.....	11,500	
Ash-handling apparatus.....	1,500	
Piping.....	27,000	
Switchboard.....	28,000	
Feed pumps.....	2,500	
Shaving feed and storage.....	8,800	
Total.....	\$312,300	

Rated H.P. boilers, 3219; engines, 3265; Kw., 2250.

TABLE 52. — SHOP ELECTRIC TRAVELING CRANES.

Shop location.	Number.	Capacity.				Motors H.P. D.C. 250 v.				Speeds in ft. per minute loaded.				Crane clearance. Ft.	Approximate cost erected. Dols.
		Main tons.	Aux'y tons.	Span. Ft.	Lift hook. Ft.	Drum hoist.	Trolley.	Bridge.	Aux'y.	Main.	Trolley.	Bridge.	Aux'y.		
Erecting.....	2	60	10	76½	25½	50	7½	50	27	10	100	250	25	24½	29,200
Machine.....	1	15	...	52	25½	27	3½	27	...	19	125	300	...	25½	5,800
Machine.....	1	10	...	52	25½	27	3	27	...	27	150	300	...	25½	5,300
Boiler.....	1	20	5	76½	25½	25	5	25	10	12	100	250	20	...	9,500
Midway.....	1	10	...	77	30	25	3	25	...	25	125	250	5,100
Foundry.....	1	10	...	60	30	25	2	25	...	25	100	350	5,000
Foundry.....	1	10	...	60	22	25	2	25	...	25	100	350	5,200
Foundry.....	1	10	...	30	12	5	...	5	...	16	...	200	2,500
Frog.....	1	2	...	30	20	3	...	3	...	10	...	200	2,000

TABLE 53. — ORDINARY YARD LIFT STEAM CRANES WITH BOILERS.

Capacity.	Radius.	Approximate cost erected.
Tons.		
1½	25	\$2000 to \$2500
2	20	1800 to 3000
2	25	2500 to 3500

TRANSFER TABLE 75 tons capacity, 75 feet long, complete with 550-volt motor A.C., travel 125 feet per minute loaded, 300 feet per minute light (cable ½ inch), \$5500 to \$6500 erected, without foundations.

The Angus shops built by the Canadian Pacific Railroad at Montreal, H. Goldmark, engineer, may be taken as a typical layout for clustered buildings of this class, and the following brief description, partly taken from the *Railway Age*, Dec. 9 and 16, 1904, embodies the principal features of each building tabulated in Table 50.

Blacksmith Shop. — Masonry foundations, brick walls with pressed brick facing, door and window sills stone, steel posts, trusses, and purlins, wood rafters covered with 3-inch plank and tar and gravel roof.

Skylights over the center running the full length of shop. Floor, 12 inches cinders. Lavatory and office accommodation inside shop, ground floor.

The building is L-shaped, with extreme dimensions 434' \times 300', one wing being 146 feet and the other 130 feet wide.

The building is opposite the gray iron foundry and car machine shop, with the long side facing the midway. In the interior of the building the wings have "hip" roofs, and each divides into three equal aisles by row of columns supporting the roof trusses. The center aisle has a clerestory equal to the width of the trusses. The building covers an area of 83,600 square feet, and is equipped with tools and furnaces for working iron. The furnaces all use oil fuel, so that there is little smoke, and the ventilation is obtained by overhead pipes connected with large exhaust fans driven by electric motors. The larger hammers, punches, and shears are located in the small wing. There are three standard gauge tracks leading from the forge to the runway and overhead crane, and also three tracks leading from the smith shop. In addition there is a longitudinal track through the center of the long portion of the building.

Cabinet and Upholstering Shop. — Masonry foundations, brick walls with pressed brick facing, door and window sills stone, wood posts and rafters in cabinet shop and steel posts and beams in storage portion and upholstering floor, roof 3-inch plank with tar and gravel covering. Skylights 10 feet wide running lengthwise over the center of the building, which is 62' \times 500'. The cabinet shop occupies half the ground floor, the other half being set apart for hardwood storage; the portion above the hardwood storage forming a second floor is used for an

upholstering room. The building is located convenient to the planing mill, the passenger car shop, and the dry kiln, and is equipped with hoists, stairs, and office accommodation inside, with a lavatory lean-to on outside of building. Ground floor, 3-inch plank on 4"×6" sleepers 4-foot centers on a 12-inch cinder bed; upper floor, 3-inch plank on wood joists.

Car Machine Shop. — Masonry foundations, brick walls with pressed brick facing and stone trimmings for door and window sills, steel posts, wood trusses and rafters covered with 3-inch plank and tar and gravel roof, skylights in each bay 12 feet wide by 60 feet long. Floor, 3-inch plank on 4"×6" sleepers 4-foot centers on a 12-inch cinder bed.

The shop is 288 by 130 feet. It has three lines of track running through it longitudinally. The cross section is divided into equal spans 43 feet 4 inches by steel columns 24-foot centers, which support the wooden roof trusses. A lean-to on one side of the building provides office, lavatory, and fan room accommodations.

Car Truck Shop. — Masonry foundations, brick walls with pressed brick facing, door and window sills stone, wood posts and rafters covered with 3-inch plank and tar and gravel roof. Floor, 3-inch plank on 4"×6" sleepers 4-foot centers on a 12-inch cinder bed. The shop is 82 by 434 feet. It is divided into three equal sections each 26 feet 8 inches span at the western portion, where steel columns and supporting steel beams are used, while the eastern portion is entirely of wood construction and here there are four sections each 20-foot span. The steel construction was used for the purpose of handling trucks from overhead supports.

On one side of the building there are two 16 by 24 feet fan houses and on the opposite side two 12 by 18 feet lavatories and toilet rooms.

Dry Kilns (soft and hard wood). — Masonry foundations, brick walls outside, wood partitions inside, wood roof covered with tar and gravel.

The dry kiln has three compartments — one for soft wood, 19 by 85 feet, one for hard wood, 19 by 85 feet, and an additional 21 by 85 feet compartment for miscellaneous work. These are equipped with patent heating apparatus. There are no end

walls, but the openings are covered by canvas doors operated by an overhead roll like a curtain.

Foundry Iron. —Masonry foundations, brick walls faced with pressed brick, window and door sills stone, steel posts, trusses, and purlins, wood rafters covered with 3-inch plank and tar and gravel roof. Skylight lengthwise along center of house. Floor, 3-inch plank on 4"×6" sleepers and 12-inch cinder bed for the chipping and tumbler room, office, sand and facing room, 12 inches sand for the molding floor, concrete for the blower room, and cinders and clay for the cupola room.

The iron foundry is 122 by 342 feet, located near the locomotive shop, with one end facing the midway. The cross section of the building is in three sections, the central one having a height of 29 feet to the lower side of the roof truss, and it is served by a traveling crane of 57-foot span and 10 tons capacity. The side wings are each 30 feet wide and 16 feet high. Over the cupola room there is a second story with a storage bin and a heavy platform, which serves as a charging floor. This is an extension to which the yard crane delivers pig iron and coke. This building covers an area of 42,700 square feet.

Data of electric traveling cranes are given in Table 52.

Freight Car Shop. —Masonry foundations, brick walls faced with pressed brick, door and window sills stone, steel posts 24-foot centers, wood trusses and rafters covered with 3-inch plank and tar and gravel roof, skylight over each bay. Floor, 3-inch plank on 4"×6" sleepers 4-foot centers on a 12-inch cinder bed; every seventh bay has a brick fire curtain wall with communicating fire doors.

The shop is 107 by 540 feet, and is served by a yard crane across one end and by four longitudinal tracks running through it. There are also two intermediate tracks for supplies and six traveling cranes fitted with air hoists for handling heavy material.

On one side of the building there are two 16 by 24 feet fan houses and one 12 by 41 feet lavatory and one 12 by 40 feet office in a one-story lean-to. The roof trusses are supported on steel columns, which carry 12-inch girders for three 1-ton traveling air hoists in each aisle of the building. The wall girders for the crane runways are carried on steel brackets bolted through the pilasters.

Frog and Switch Shop. — Masonry foundations, brick walls faced with pressed brick, window and door sills stone, steel columns and purlins, wood rafters covered with 3-inch plank and tar and gravel roof. Skylights along center of shop. Floor, 3-inch plank on 4"×6" sleepers at 4-foot centers and 12-inch cinder bed.

The shop is 102 by 264 feet, has a single track extending through it, and is also served by a 33-foot 2-ton traveling crane in two of the three sections into which it is divided. Data of electric traveling cranes are given in Table 52.

Locomotive, Erecting, and Machine Shop. — Masonry foundations, brick walls faced with pressed brick, door and window sills stone, steel posts and trusses, wood rafters covered with 3-inch plank and tar and gravel roof, with skylights and ventilators, 3-inch plank floor on 4 by 6 sleepers at 4-foot centers on a 12-inch cinder bed.

The locomotives are handled by two 60-ton cranes of 77-foot span, each with 10-ton auxiliary hoist.

In the machine shop there is one 15-ton crane of 77-foot span, with a runway which is the extension of the erecting shop. All cranes driven by continuous-current motors at 250 volts.

The walls of the locomotive shop are 48 feet high to the eaves; they are divided into panels 22 feet wide by pilasters which carry the roof trusses. Each panel has two windows 12 feet wide and 16 feet high. In each roof panel there is a transverse monitor 12 by 72 feet, with double pitched skylight roof, and in the sides 2 by 3 feet ventilating doors.

On the east side of the shop there are four 12 by 24 feet one-story extensions, which are used as lavatories. The balcony is used for a sheet-iron shop and for light machinery.

The boiler shop occupies 300 feet of the south end of the building, is supplied with a 17-foot gap hydraulic riveter, and above it the riveting tower, which occupies one panel of the 80-foot bay, is 65 feet from top of rail. There are two 25-ton hydraulic cranes.

The shop equipment is a hydraulic triple punch and a two-plunger flanger, four riveting furnaces and a flange furnace, hydraulic punch and shears, small hydraulic riveter, hydraulic

pump, the machine tools served by cranes 50-foot span, one 15-ton and the other 10.

The machines include a very long planer, a heavy 3-headed frame slotted machine and a driving wheel press and a milling machine for cylinders, a four-spindle frame drilling machine direct driven by four motors, and one electric oil pump, 3-spindle cylinder borer direct driven, 10-horsepower motor, a cylinder planer direct driven by electric motor, large driving wheel lathe.

Two 10-ton cranes for the outside runways, with one 25-horsepower and 8-horsepower direct-current 250-volt motors.

One 20-ton 77-foot crane in the boiler section of the locomotive shop, and one 10-ton 50 feet span crane in the iron foundry, and one 10-ton crane in the engine room of the power plant, and in addition a number of small cranes and air hoists in the other shops.

Data of electric traveling cranes are given in Table 52.

Offices (Main). — Masonry foundations, brick walls faced with pressed brick, door and window sills stone, wood floors and partitions, slate roof. Interior natural finish and plastered walls burlapped 6 feet high in halls. Lavatory and toilet accommodations on each floor.

The building is 56 by 80 feet, three stories high, with a basement and attic near the center of the building. The basement to be used for testing room, lavatory and heating apparatus, storage and small offices. The first floor is for clerks and storekeepers, the second for officials of rolling stock and car builders, and the third for drafting room and blue-print room.

Passenger Car Shop (Erection and Paint). — Masonry foundations, brick walls faced with pressed brick, door and window sills stone, wood posts, and rafters covered with 3-inch plank and tar and gravel roof, skylights in each bay, floor 3-inch plank on 4 by 6 sleepers at 4-foot centers on a 12-inch cinder bed.

The passenger car erection and paint shops are each 100 by 672 feet, and they are served by an electric transfer table 75 feet long operated by a 20-horsepower alternating-current motor. Each shop has 28 tracks spaced 24 feet center to center. On account of the peculiarity of track approach to the shop grounds,

necessitated by the contour of the shop yard, the transfer pit is placed with longitudinal axis parallel to the long shops. In the passenger department the cars enter the transfer table by a long curve from the main shop track.

Pattern Storage. — Masonry foundation, brick walls with pressed brick facing, door and window sills stone, steel posts and rafters and reinforced concrete roof covered with tar and gravel, with skylights over roof. Intermediate wood posts support the floors.

Ground floor, concrete on a sand bed; first and second floors, heavy floor beams and $4\frac{1}{4}$ by $3\frac{1}{4}$ flooring with $1\frac{1}{2}$ -inch air spaces.

The building is 50 by 150 feet, and is three stories. Inside light only is obtained from skylights in the roof. The four exterior doors are covered with galvanized iron.

Pattern Shop. — Masonry foundation, brick walls faced with pressed brick, window and door sills stone, wood posts, beams and rafters covered with 3-inch plank and tar and gravel roof. Ground floor, 3-inch plank on 4 by 6 sleepers 4-foot centers and 12-inch cinder bed. First floor, 2-inch T. and G. planks on $6'' \times 12''$ joists about 4-foot centers.

The pattern shop is 50 by 82 feet, two stories high, and is located on the midway opposite the blacksmith shop.

Planing Mill. — Masonry foundations, brick walls faced with pressed brick, window and door sills stone, steel posts, wood trusses and rafters covered with 3-inch plank and tar and gravel roof, with skylights over each bay.

Floor, 3-inch plank on $4'' \times 6''$ sleepers 4-foot centers on 12-inch cinder bed. The planing mill is 126 by 500 feet, similar in construction to the car machine shop, but has one row of columns which divides it into longitudinal aisles. There is a track passing through the center of each aisle and one transverse track with turntables at the intersection which connects with the dry kiln.

Power House. — Masonry foundation, brick walls faced with pressed brick, steel trusses, wood rafters covered with 3-inch plank and waterproof covering with a 2-inch air space and a covering of $1\frac{1}{4}''$ T. and G. boards on top finished with tar and gravel roof with skylights over. Boiler and pit duct room floors 6 inches concrete, engine room floor hardwood. A steel frame is placed

around the smoke stack, leaving two feet clear on each side. The stack is also insulated by sheet steel and heavy asbestos board to guard against fire.

The house is located near the planing mill in order to use the refuse lumber and shavings. The building is 101 by 168 feet, divided by a longitudinal middle wall into boiler and engine room. The engine room is equipped with a 10-ton traveling crane.

Engine and generator equipments are as follows: Three 750 and one 375 horsepower cross compound horizontal Corliss engines, making 150 revolutions per minute, direct connected to three 500-kilowatt and one 250-kilowatt, three-phase, 300-volt, alternating-current generators; two 250-kilowatt, 250-volt direct-current dynamos for the crane service, air compressors to supply air at 100 pounds pressure through one seven-inch and one two-inch main leading to the different shops.

In the boiler house there are four 416-horsepower boilers working under a pressure of 150 pounds and one 300-horsepower boiler at 300 pounds working pressure used in testing locomotives; boilers hand stoked, equipped with shaking grates.

There is a shaving exhaust system for supplying the boilers with the refuse from the planing mill. The induced system of draft is used on the boilers, and the stack is of steel 8 feet in diameter and 70 feet high. The induced draft is operated by two 10-foot fans each making 200 revolutions per minute. Two economizers are used and are sufficient for the five boilers already installed. Further data of cost are given in Table 51.

The boiler connects with a 12-inch header, and there are reducing and by-pass valves provided to permit high-pressure steam to be used in the mains from the low-pressure battery.

There are two 12"×7"×12" and two 6"×3½"×6" feed pumps, also feed water heater. Underneath the boiler house is a tunnel terminating at an air hoist for lifting the ash cars to the surface track. The ashes are discharged to floor hoppers, from which they are emptied into the tunnel cars. The steam pipes are carried from the power house to the several buildings in a tunnel 6 feet high, 4½ feet wide, built of brick. Wall brackets carry the live steam pipes for heating by night and exhaust steam by day, a high-pressure steam pipe for locomotive tests, the compressed

air pipes, and a return pipe for drainage of all the heating apparatus. The steam exhaust pipes are covered with asbestos air cell covering wired on. A few of the smaller mains are carried underground in wooden boxes. The distribution of electric power to the different shops is by bare wire on steel poles.

Data of miscellaneous power house equipment are given in Table 51 and electric traveling cranes in Table 52.

Stores. — Masonry foundations, brick walls faced with pressed brick, door and window sills stone, wood posts and rafters covered with 3-inch plank and tar and gravel roof. Ground floor, 3-inch plank on 4 by 6 sleepers 4-foot centers on a 12-inch cinder bed; second floor, 2-inch T. and G. plank on heavy joists.

The house is 85 by 594 feet, and is located with one end facing the midway directly opposite the end of the large machine shop. This building is two stories high; it has wooden roof girders supported by three longitudinal rows of wooden columns, which carry a center gallery supported on joists between girders. The sills of the windows are $13\frac{1}{2}$ feet above the floor line to allow for storage racks and shelves on the walls below them. The gallery is lighted by 12-foot standard monitors extending the whole length of the building.

Offices, scales, hoists, and lavatory and toilet accommodation are provided on the ground floor.

Wheel Foundry. — Masonry foundations, brick walls faced with pressed brick, door and window sills stone, steel posts, trusses, and purlins, wood rafters covered with 3-inch plank and tar and gravel roof; skylights in each bay; moulding floor, 12 inches cinders and clay.

The foundry is located on the extreme northwest portion of the yard and is convenient to the freight car and truck shops. It is 107 by 187 feet, and is divided into three sections transversely, two of them of 52 feet 6 inches span. The cupola room, 27 feet wide, is two stories, having a length of 90 feet, and the second floor is built like that on the iron foundry, having a charging floor on the opposite side. There is a one-story extension 12 by 27 feet for toilet room and lavatory. At each end of the building 40 feet is used for the annealing pits, and this is served by a 3000-pound crane, running transversely to the

longitudinal axis of the building. This building covers an area of 24,300 square feet.

Electric and Telephone Installation.— There are about 200 electric motors used in the different shops, and only 15 of them are of the variable-speed type. All the machine tools, cranes, transfer table, heating and exhaust and the various draft fans are motor driven. The constant-speed motors are of three-phase induced type, using current at 550 volts.

In the buildings there is a mixed system of open porcelain cleats and slow-burning waterproof wire in the ceiling and Richmond conduits and rubber-covered wire on the side walls. Cut-out boxes are supplied for about every 100 horsepower of motor wire and every 10 kilowatts of lighting. The shops and yards are lighted with four hundred 110-volt enclosed arc lamps and in addition 3800 16-candlepower incandescent 110-volt lamps.

In the passenger car shops low extension arc lamps are installed.

In the yard there are 50 enclosed series arc lamps.

There is a complete telephone system using fixed telephones connecting to long-distance wires.

This system is equipped with metallic circuit, electric generators for ringing, and self-restoring drops.

CHAPTER VIII.

INSTRUCTIONS REGARDING SPECIFICATIONS, PROPOSALS, CONTRACTS, PLANS, AND ESTIMATES.

Specifications and Forms.

ENGINEERS should be supplied with printed copies of the specifications and forms mentioned in the list given below. They are intended to cover the entire general field of railroad construction, and to be used for all contract work.

Preferably complete plans and specifications should be furnished to contractors.

When calling for bids use the Standard Printed Specifications with Form F. 4, d, 1 attached for buildings and kindred structures, and Form F. 4, d, 2 for general railroad construction.

To make a complete specification it is only necessary to insert the numbers of such clauses (from the printed specifications) as may be desired opposite the given items. (See Form.)

Unit Prices.

Buildings and Kindred Structures.—The usual custom is to obtain unit prices in addition to lump sum prices for the various trades and a lump sum for the entire work, as itemized on the form.

When unit prices are not necessary a note to that effect can be written across the columns.

General Railroad Construction.—The contract is governed principally by unit prices, though approximate quantities are often given and itemized as a lump sum bid.

It is obvious, however, that such quantities should not enter into the contract as final but simply given as a fair approximate estimate, the contractor to be paid for the actual work done, more or less as the case may be.

When making a comparison of bids received on unit prices the engineer usually has his estimated quantities from which he figures the probable cost of the work, and incidentally is enabled to detect unbalanced bids, that is, bids sent in with a low total and high and low unit prices; the contractor, figuring on the probable variation of the most likely quantities and those that will not vary very much, manipulates his units accordingly, so that should he get the work the final results under ordinary circumstances will generally be to his advantage and detrimental to the company.

The proposal and contract forms generally, are from Canadian Pacific Railway Company's standards.

LIST OF STANDARD SPECIFICATIONS AND FORMS.

<p>A.</p> <p>1. Angle Bars. 2. Ash Pits. </p> <p>B.</p> <p>1. Bolts. 2. Boiler Houses. 3. Bunk Houses. 4. Bridges, Steel (Section A, B, C, D, E, and F). 5. Building Specification (General). </p> <p>C.</p> <p>1. Cement, Sand, and Water. 2. Concrete (Class A, B, and C). 3. Concrete Culvert Pipe. 4. Concrete Arch Culverts. 5. Concrete Rail Culverts. 6. Cribs. 7. Cast-iron Pipe. 8. Cattle Guards. 9. Coaling Plants. 10. Construction (Clearing, Grubbing, etc.). 11. Color Card (Standard). 12. Coal and Oil Sheds. 13. Car Sheds. </p> <p>D.</p> <p>1. Dams. </p> <p>E.</p> <p>1. Engine Houses. </p>	<p>F.</p> <p>1. Fences, Wood (Snow, etc.). 2. Fences, Wire (right of way). 3. Freight Sheds. 4. Forms. 4a. Notice to Contractors (asking bids). 4b. Proposal (Brief description proposed work). 4c. Contract (Final). 4d. Standard Specification, Forms 1 and 2. 4e. Notice to Successful Bidder (Award of Contract). 4f. Notice to Unsuccessful Bidders (Result of Contract). 4g. Estimating, Summary List. 4h. Estimating, Detail List. </p> <p>G.</p> <p>1. Gates. </p> <p>H.</p> <p>1. Heating. </p> <p>I.</p> <p>1. Ice Houses. 2. Interlocking. </p> <p>M.</p> <p>1. Masonry. </p> <p>O.</p> <p>1. Oil Houses. </p>	<p>P.</p> <p>1. Privies. 2. Pump Houses. 3. Pumps and Boilers. 4. Paint. 5. Piling. </p> <p>R.</p> <p>1. Rails, Steel. 2. Repair Sheds. </p> <p>S.</p> <p>1. Shanties. 2. Stone Masonry (Class A, B, C, D, and E). 3. Stone Arch Culverts. 4. Stone Box Culverts. 5. Spikes (Steel) 6. Stations. 7. Switches. 8. Stock Yards. 9. Storehouses. 10. Sand Houses. 11. Section Houses. 12. Shelters. 13. Standpipes. 14. Sign Posts. 15. Scrap Sheds. </p> <p>T.</p> <p>1. Tile Pipe Culverts. 2. Tool Houses. 3. Timber Culverts. 4. Track Work. 5. Track Scales. 6. Ties. 7. Turntable and Pit. 8. Tunnels. 9. Trestles (Timber). 10. Trestles (Steel). </p> <p>W.</p> <p>1. Water Tanks. </p>
--	---	--

..... RAILWAY COMPANY.

SPECIFICATIONS

Of the Material and Work necessary for the Erection and Completion of a..... at..... according to the plans numbered.....

General:— The prices shall include all labor and material for the work complete, in accordance with the printed specifications attached more particularly under the clauses mentioned as follows:—

ITEMS.	SPEC. No.	CLAUSES.	UNIT.	PRICE	CONTRACT PRICE.
<i>Excavation, Grading, etc.:</i>					
Excavation (except rock).....	B5-1	1, 2, 3, 4, 5,	Per cu. yd.	\$	
Excavation, etc.....			Rock, per cub. yd.	\$	
Piling.....			Driven, per lin. ft.	\$	
Drains.....			In place, lin. ft.	\$	
Manholes.....			In place, each ..	\$	
Agricultural drains.....			In place, lin. ft.	\$	
Cinder fill.....			In place, cub. yd.	\$	
			<i>Contract Price</i> ..	\$	
<i>Cement, Sand, etc.:</i>					
Cement, sand and water....	C1	1, 2, 3, 4, 5, 6, 7, 8		\$	\$
			<i>Contract Price</i> ..	\$	\$
<i>Stone Masonry:</i>					
Stone, etc.....	B5-2	1 to 10 inclus.		\$	
Masonry (walls above grade).....			11, Class.....	Super. sq. ft.	\$
Masonry (walls below grade).....		11, Class.....	Cubic yd.	\$	
Piers, etc.....			Cubic yd.	\$	
Damp proofing.....			Sq. (100 sq. ft.) ..	\$	
Mortar.....			<i>Contract Price</i> ..	\$	\$
<i>Brick Work:</i>					
Brick, etc.....	B5-3	1 to 12 inclus.		\$	
Common brick.....				In place, per M.	\$
Face brick.....			In place, per M.	\$	
Paving brick.....			In place, per M.	\$	
Mortar.....				\$	
Fireplaces, hearths, etc.....				\$	
			<i>Contract Price</i> ..	\$	\$
<i>Concrete, etc.:</i>					
Concrete.....	B5-4	1 to 26 inclus.		\$	
Reinforced steel.....				In place, per lb.	\$
Concrete, Class "A".....			In place, cu. yd.	\$	
Concrete, Class "B".....			In place, cu. yd.	\$	
Concrete, Class "C".....			In place, cu. yd.	\$	
Damp proofing.....			Sq. (100 sq. ft.) ..	\$	
Concrete pits.....			In place, cu. yd.	\$	
Machine foundations.....			In place, cu. yd.	\$	
Pipe ducts.....			In place, cu. ft.	\$	
Encasing steel.....			In place, cu. ft.	\$	
Solid concrete floors.....			In place, sq. yd.	\$	
Platforms and sidewalks.....			In place, sq. yd.	\$	
			<i>Contract Price</i> ..	\$	\$
<i>Carpentry, etc.:</i>					
Timber, etc.....	B5-5	1, 2, 3, 4, 5; 6, 7, 8, 9, 10, 11, 12.	M. ft. B. M.	\$	
Millwork, etc.....				do.	\$
Doors and windows.....		13 to 29 inclus.		\$	
Interior work.....				\$	
Exterior work.....				\$	
Exterior finish.....				\$	
Interior finish.....				\$	
			<i>Contract Price</i> ..	\$	\$

ITEMS.	SPEC. No.	CLAUSES.	UNIT.	PRICE	CONTRACT PRICE.
<i>Hardware Fittings, etc.:</i>					
Hardware, etc.	B5-6	1, 2		\$	
Grates and frames			In place, per set.	\$	
Stop post fittings			In place, per post.	\$	
Complete shop door fittings			In place, per door	\$	
Smoke jacks			In place, per jack	\$	
Track rails, etc.				\$	
				<i>Contract Price</i>	\$
<i>Roofing, Flashing, etc.</i>					
Roofing	B5-7		Sq. (100 sq. ft.)	\$	
Flashing			Super. sq. ft.	\$	
Skylights			In place, sq. ft.	\$	
Ventilators			In place, each.	\$	
				<i>Contract Price</i>	\$
<i>Plumbing:</i>					
Plumbing, etc.	B5-8	1 to 14 inclus.		\$	
Water closets			In place, each	\$	
Baths			do	\$	
Lavatories			do	\$	
Urinals			do	\$	
Sinks			do	\$	
Water supply, etc.				\$	
				<i>Contract Price</i>	\$
<i>Plastering, etc.:</i>					
Plastering	B5-9	1, 2, 3, 4, 5	Per sq. yd.	\$	
Cornices			Girth, meas. sq. yd.	\$	
				<i>Contract Price</i>	\$
<i>Painting, Glazing, etc.:</i>					
Painting	B5-10	1, 2	3 coats, sq. yd.	\$	
Glazing		3	16 oz. sq. ft.	\$	
Kalsomining			Per sq. yd.	\$	
Whitewashing			do	\$	
Finish			do	\$	
				<i>Contract Price</i>	\$
<i>Electric Wiring, etc.:</i>					
Wiring, etc.	B5-11	1 to 9 inclus.		\$	
Outlets			In place, each	\$	
Wall switches			do	\$	
Circuit switches			do	\$	
Fixtures				\$	
				<i>Contract Price</i>	\$
<i>Heating, etc.</i>					
Hot water heating	H1			\$	
Steam boiler heating				\$	
Steam vacuum heating and steam, air and water pipes.				\$	
Hot air heating and steam, air and water pipes.				\$	
				<i>Contract Price</i>	\$
<i>Steel Work:</i>					
Structural steel	B5-12		Erected, per lb.	\$	
Cast iron			Erected, per lb.	\$	
				<i>Contract Price</i>	\$
<i>Miscellaneous:</i>					
For work not included in specification but shown on plan or vice versa, briefly as follows:					
				<i>Contract Price</i>	\$
				<i>Total Contract Price</i>	\$

The Unit Prices given will govern in cases of deductions or additions, after the contract is let, subject to "General Contract Conditions."

Signature of Witness.

Signature of Contractor.

..... RAILROAD COMPANY.

SPECIFICATIONS*Of the Material and Work Necessary for the Building*of a
from to

General:—The prices shall include all labor and material for the work complete, in accordance with the printed specifications attached more particularly under the clauses mentioned, as follows:—

ITEMS.	Plan No.	Spec. No.	CLAUSES.	UNIT.	PRICE	Approx Quantities	AM'T. \$
<i>Roadway:</i>							
Trees reserved				Per cord, 128 cu. ft.			
Clearing				100 ft. sq.			
Grubbing				do.			
<i>Grading:</i>							
Excavation, common				Cu. yard			
Excavation				do.			
solid rock				do.			
loose rock				do.			
Tile sub-drains				Ft., in place			
Crosswaying				100 ft. sq.			
Dangerous trees				Per tree removed			
Extra haul				Cu. yd. (100) ft.			
<i>Tunnels:</i>							
Excavation, common				Per cu. yd.			
rock				do.			
Timber				M. ft. B. M., in pl.			
Wrought iron				Per lb., in place ..			
Cast iron				do.			
<i>Structures:</i>							
Excavation, common				Per cu. yd.			
rock				do.			
rock under water				do.			
<i>Cement, etc.:</i>							
Cement, sand and water							
<i>Stone Masonry:</i>							
Class "A"				Cu. yd., in place.			
"B"				do.			
"C"				do.			
"D"				do.			
"E"				do.			
Arch culverts				do.			
Box culverts				do.			
<i>Concrete Masonry:</i>							
Class "A"				Cu. yd., in place.			
"B"				do.			
"C"				do.			
Stone facing				Sq. ft., in place..			
Arch culverts				Cu. yd., in place.			
Rail culverts				do.			

ITEMS.	Plan No.	Spec. No.	CLAUSES.	UNIT.	PRICE	Approx Quantities.	AM'T. \$
<i>Pipe Culverts:</i>							
Cast iron pipes.....				Lin. ft., in place.			
Concrete pipes.....				do.....			
Tile pipes.....				do.....			
<i>Paving, etc.:</i>							
Riprapping, hand laid.....				Cu. yd., in place.			
loose.....				do.....			
Paving.....				do.....			
<i>Timber, etc.</i>							
Piles.....				Lin. ft., in place.			
Sheet piling.....				M. ft. B. M. in pl.			
Grillage.....				do.....			
Coffer-dams.....				do.....			
Cribs (frame).....				Cu. yd., in place.			
Cribs (log).....				do.....			
Box culverts.....				M. ft. B. M., in pl			
<i>Trestles:</i>							
Timber excepting stringers.....				M. ft. B. M., in pl			
Timber stringers.....				do.....			
Wrought iron or steel.....				Per lb., in place.			
Cast iron.....				do.....			
<i>Wooden Bridges:</i>							
Timber.....				M. ft. B. M., in pl			
Steel rods upset.....				Per lb., in place.			
Steel truss plates.....				do.....			
Cast iron.....				do.....			
Other iron and steel.....				do.....			
<i>Open Culverts:</i>							
Timber except stringers.....				M. ft. B. M., in pl.			
Timber stringers.....				do.....			
Steel and iron.....				Per lb., in place.			
<i>Cattle Guards:</i>							
Wood cattle guards.....				Per Xing. in place			
Metal cattle guards.....				do.....			
<i>Fencing and Gates:</i>							
Seven-wire fence.....				Erected, per mile			
Five-wire fence.....				do.....			
Picket fence.....				Erected, per lin.			
Ft. wood gates.....				ft.			
Ft. steel gates.....				Per gate, erected.			
do.....				do.....			
<i>Farm Crossings, etc.</i>							
Ft. farm crossing.....				In place complete			
Ft. farm crossing.....				do.....			
Ft. public road crossing.....				do.....			
<i>Sign Posts:</i>							
Mile posts.....				Each, in place			
Mile boards.....				do.....			
Station mile board.....				do.....			
Rail rack posts.....				do.....			
Whistle posts.....				do.....			
Highway crossings signs.....				do.....			
Railway crossings signs.....				do.....			
Stop posts.....				do.....			
Slow posts.....				do.....			
Yard limit boards.....				do.....			
Trespass signs.....				do.....			
Section posts.....				do.....			
Elevation posts.....				do.....			

ITEMS.	Plan No.	Spec. No.	CLAUSES.	UNIT.	PRICE	Approx Quantities.	AM'T. \$
Flanger posts				Each, in place			
Wing posts				do			
Bridge warning				do			
Bridge and trestle number				do			
Culvert number				do			
<i>Track Work:</i>							
Ballast, gravel				Per cu. yd., in pl.			
cinder				do			
dirt				do			
stone				do			
Ties, No. 1				Each, in place			
No. 2				do			
culls				do			
switch				do			
Track laying				Per set, in place			
Surfacing, Class "A"				Per mile, in place			
"B"				do			
<i>Buildings and Kindred Structures:</i>							
Ash pits				Built complete			
Boiler houses			See Form	do			
Bunk houses				Per sq. ft. in place			
Coal platforms				Built complete			
Coaling plants				do			
Coal and oil sheds				do			
Car sheds				do			
Engine houses				do			
Freight sheds				do			
Oil houses				do			
Privies, No. 1				do			
No. 2				do			
Pump houses				do			
Repair sheds				do			
Sand houses				do			
Section houses, single				do			
double				do			
Stations, No.				do			
No.				do			
No.				do			
Storehouses				do			
Scrap sheds				do			
Shelters				do			
Standpipes				do			
Tool houses, single				do			
double				do			
Track scales				do			
Turntable and pits				do			
Water tanks				do			
Watchman's shanties				do			
<i>Miscellaneous:</i>							

The above unit prices to govern all contract work, subject to general contract conditions.

.....
Signature of witness.

.....
Signature of contractor.

Proposals.

Proposals Called For.— Proposals, specifications, and all forms necessary will be filled out in detail by the engineer.

Sufficient time should be given contractors, so as to secure appropriate competition.

Bids shall be called for by issuing the following:—

Notice to contractors	Form F. 4a	See page 231.
Proposal	“ F. 4b	“ “ 232.
Contract	“ F. 4c	“ “ 234.
Specification	“ F. 4d, 1 or 2	“ 222,
Contract drawings (blueprints).		

Lack of commercial standing on the part of the bidder will constitute good and sufficient ground for the rejection of bid.

Abnormally low bids should be subjected to the strictest scrutiny and comparison with prevailing market rates.

All bids received from contractors who have failed unjustifiably to fill former contracts with the company shall be rejected.

Careful investigation will be made of the financial status of individual bondsmen offering themselves as securities on contractors' bonds, and no bonds of individuals shall be accepted until it is conclusively shown to the satisfaction of the engineer that such bonds afford ample security to the company for the fulfilment of the undertaking in question.

Accepted Proposals.— Proposals in duplicate will be forwarded to the Engineer, accompanied by proper recommendations.

Accepted proposals will be signed by the Engineer, and one copy returned to the engineer for the preparation of contract.

Engineers will advise successful bidders of award of contract, Form F. 4e, and will issue instructions for the prosecution of the work, and will advise all contractors who have tendered the result of award of contract, Form F. 4f.

In cases of special urgency, authority to proceed immediately with the work may be obtained by telegraphing rates and amount of lowest acceptable tender, but proposals to cover must be prepared and forwarded without delay.

Unimportant work for amounts not exceeding \$500 may be performed without the execution of formal contracts. In such cases acceptance by the.....Engineer will be noted on the face of the proposal in duplicate, and one copy will be returned to successful bidder. Such proposals will take the place of formal contracts.

Contracts.

Preparing Contracts. — Upon receipt of advice of accepted proposals, contracts, Form F. 4c, should be promptly prepared by the engineer in duplicate. When duly executed by contractors, contracts, with two extra copies, should be sent to the..... Engineer, with accepted proposals attached for execution by the Company.

After execution by the company one original and one copy will be returned to the engineer, who will deliver original to the contractor.

In preparing contracts the following instructions should be observed: —

1. When the contractor is an individual (not a firm or corporation), his full name and residence should be inserted on the first page. He should sign the contract in his ordinary signature on the line above the words "signature of contractor," and a seal should be put opposite the signature over the small circle at the end of the said line. If there is more than one individual, have him do so in a similar manner, in the space above said line, a separate seal being put opposite each signature.

2. When the contractor is a firm, the preferable way is to make each member of the firm a party and have him sign the contract. For instance, a contract is being made with the firm of Smith, Brown & Jones, of which the partners are John Smith, Robert Brown and James Jones. On the first page of the contract, describe the contractor as John Smith, Robert Brown and James Jones, carrying on business at London, County of Simcoe, Ontario, under the firm name and style of "Smith, Brown & Jones." Have each member of the firm execute the contract in the same manner as is described above in paragraph one.

3. When the contractor is a corporation, care should be taken to see that the proper name of the corporation is inserted on the first page as the contractor. The corporate seal of the corporation should always be affixed to the contract, and the contract signed by its duly authorized officer or officers as in the following example:

PREAMBLE: "The Railway Construction Company Ltd., carrying on business, and having its head office at the City of New York, in the state of New York."

Execution: —

THE RAILWAY CONSTRUCTION COMPANY, LTD.

Signed, sealed and delivered
by the contractor in pres-
ence of

JOHN JONES,
President.

PETER ROBINSON,
Secretary.

..... [CORPORATE]
..... [SEAL]

4. The execution by the parties to the contract should be witnessed separately or collectively as required, and the witness or witnesses should sign immediately under the words "Signed, sealed and delivered by the contractor," etc.

5. Where plans or specifications do not accompany contract, the portion of clause 1 relating to same should be stricken out. If work is in accordance with Standard Plans or Specifications reference may be made to same in space allotted to the description of the work. In this space, reference should also be made to tender on which contract is based.

6. Clause 16 is to be used solely for schedule of sums and prices to be paid by the company.

7. Additional clauses, if any, may be written on page 4, below schedule of prices, and should be numbered 16 (A), 16 (B), etc. If necessary, blank sheet 4 (a) can be inserted, and additional clauses continued on same.

8. A time for completion should be agreed upon, and a penalty clause for noncompletion within specified time inserted. The clause should be of the following general form: —

"The penalty for the noncompletion of the work in the time specified shall be.....dollars per day for each and every day

which may elapse between the time specified and the actual completion of the work, and the sum shall be deducted from the amount of the contract price."

9. A strike clause should also be inserted if desired, as follows:

"The contractor agrees in the event of strikes or labor trouble for increase in rate of wages, to pay such increase if demanded by the Company, and shall not hold up or delay the work for the causes mentioned."

Carrying Out Contract. — Contracts once executed will be strictly construed, and no variation from standards, specifications or plans will be permitted.

If it be demonstrated that contract requirements are unreasonable, or that the work is not practicable, or that for any reason the stipulations cannot be rigidly applied or enforced, the matter must be taken up with the Engineer in charge.

To sanction any variation or to relax stringency in any particular of an existing contract is irregular and is likely to give the contractor an advantage which is unfair to competitors whose proposals were based on the expectation of being held to the strictest observance of the specifications.

All supplies furnished under contract will be subjected, whenever practicable, to the personal inspection of the Engineer at the time of delivery, and in the case of work being fabricated in a shop, the inspection is to be made before shipping, such inspection to be made by competent inspectors, subject to test and verification at irregular intervals by the Engineer in charge.

NOTICE TO CONTRACTORS.

FORM F. 4a.

.....RAILWAY COMPANY.

ENGINEERING DEPARTMENT.

.....19....

To.....

.....

SIR: — You are requested to tender on the following work:

.....
.....
.....

Copies of the Proposal, Specification, Contract and Drawings, together with any supplementary information required, can be had on application. Sealed proposals will be received at the office of the..... until 12 o'clock noon on the.....day of..... 19..... under the following conditions:

Proposals must be made on forms furnished by the Company.

All blank spaces and unit prices in the proposal must be filled in, and no change shall be made in the phraseology of the proposal or additions to the items mentioned therein.

The Contractor is expected to examine the Specifications and Plans, to visit the locality of the work, and to make his own estimate of the facilities and difficulties attending the execution of the proposed work and the completion of same within the time specified.

All Drawings, Specifications and Proposal Forms furnished by the Company shall be returned to the Engineer with the proposals.

The Contractors' bond will be.....per cent of the amount of his proposal.

Proposals must be in sealed envelopes addressed to..... and the envelopes endorsed "Proposal for....."

.....
.....

PROPOSAL.

FORM F. 4b.

..... RAILWAY COMPANY.

ENGINEERING DEPARTMENT.

For.....

(Location)..... Division.....

The undersigned hereby propose, and if this proposal is accepted, agree to enter into a written contract, if required, with the..... Railway Company to supply all labor and material and complete all work according to the plans and directions of the Engineer for said Railway Company, in conformity with the specifications attached hereto, upon the terms and conditions of the contract prepared therefor, and within the time specified, as follows:

All the above work to be completed on or before19....

The information upon which this proposal is based was obtained by the proposer through his own sources of knowledge, and was not derived from any officer or agent of the Railway Company.

The Railway Company reserves the right to reject any and all bids, and, at its option, to require a satisfactory bond from the contractor for faithful performance of the work.

The Railway Company shall be given preference at equal rates on all competitive shipments, and no such shipments will be routed via foreign lines without prior notice to its Traffic Department.

This Proposal is made with the understanding that no free or reduced rates whatever will be given by the Company on account of this work, and that full tariff freight and passenger rates will be paid by the contractor.

Signature of Proposer.....

Address.....

Date.....19....

FORM F. 4f.

.....RAILWAY COMPANY.

ENGINEERING DEPARTMENT.

.....19.....

To.....

.....

SIR: — I beg to advise that the contract for.....

.....

has been awarded to another contractor and desire to thank you for bid received. If you have not already done so, please return all plans, specifications and proposals.

Yours truly,

.....

FORM F. 4e.

.....RAILWAY COMPANY.

ENGINEERING DEPARTMENT.

.....19.....

To.....

.....

SIR: — I beg to advise that your bid for.....

.....

has been accepted and duplicate copies of the Contract, Specifications, and Plans are in this Office waiting your signature for execution. Your prompt attention to the same is requested.

Yours truly,

.....

GENERAL CONTRACT FORM.

FORM F. 4c.

This Agreement, made in duplicate the.....
day of....., 19.....
 BETWEEN.....

 hereinafter called "the Contractor," of the one part, and
 THE RAILWAY COMPANY, herein-
 after called "the Railway Company," of the other part,
 witnesseth as follows:

Covenant to do work

(1) In consideration of the covenants and agreements hereinafter contained and to be performed by the Railway Company and of the prices hereinafter mentioned the Contractor hereby covenants and agrees with the Railway Company that he will furnish all labor, services and material required by this contract, and will construct, complete and finish in the most thorough, workmanlike and substantial manner in every respect to the satisfaction and approval of the.....Engineer for the time being of the Railway Company, in the manner herein specified and limited and according to the Plans and Specifications hereto annexed, and which, for the purposes of identification, have been signed by the Contractor and the Secretary of the Railway Company and form part of this contract, and will, on or before the.....day of..... next (time being of the essence of the contract), finally complete and deliver to the Railway Company the following work, that is to say:

Date of completion.

Description of work.

.....

 it being understood that if anything has been omitted from or has been misstated, in the plans or specifications which is necessary for the proper performance and completion of any part of the work contracted for, the Contractor shall, at his own expense, execute the same as if it had been inserted and properly described as the case may be, and the correction of any such error or omission shall not be deemed to be an addition to or a variation from the works hereby contracted for.

(2) The Railway Company or its.....Engineer shall appoint a representative of the Railway Company on the work, and such representative, or any substitute, and any assistant duly appointed by such representative or substitute shall, in this agreement and in the specifications, be referred to as "the Engineer." Ry. to appoint representative.

(3) The said work shall be commenced immediately after the execution of this agreement, and shall be proceeded with continuously and diligently and under the personal supervision of the Contractor until completed. The work shall be carried on and prosecuted in all its several parts in such manner and at such times and at such points or places as the Engineer shall from time to time direct and to his satisfaction, but always according to the provisions of this agreement, and if no direction is given then in a careful, prompt and workmanlike manner according to this agreement. Commencement.

(4) This agreement shall not be assigned, nor shall the said work or any part thereof be sub-contracted without the written consent of the Engineer to every such assignment or sub-contract. Assignment

(5) The Contractor will in all things conform to and comply with the instructions of the Engineer. All work or material which, in the opinion of the Engineer, is imperfect or insufficient shall be remedied when pointed out to the Contractor by the Engineer, and will be made good and sufficient by the Contractor at his own expense and to the satisfaction of the Engineer, who shall have the power, and whose duty it shall be, to have any defective work or material taken out and rebuilt or replaced at the expense of the Contractor. Any omission by the Engineer to disapprove of or reject any insufficient or imperfect work or material at the time of any estimate shall not be deemed an acceptance of such work or material. Imperfect work.

(6) The Contractor will not bring or permit to be brought anywhere, on or near the said work, any spirituous or intoxicating liquors and if any foreman, laborer or other employee or contractor shall, in the opinion of the engineer, be intemperate, disorderly, incompetent, wilfully negligent or dishonest in the performance of his duties, he shall on the direction of the engineer, be forthwith discharged, and the Contractor shall not employ or permit to remain upon the Intoxicating liquors.

work, any person who shall have been discharged from the said work for any or all of the said causes.

Extra work.

(7) No extra work or material is to be allowed or paid for, excepting only upon a previous order in writing of the Engineer and any and all claims for extra work or material must be presented to the Engineer for allowance at the close of the month in which the same shall have been done or furnished and shall be included in the estimate for that month, otherwise all claims therefor shall be deemed absolutely waived by the Contractor, and the Railway Company shall not be required to allow or pay for the same, but may exercise its option concerning such payments.

Stoppage of work and reduction of force.

(8) Whenever in the opinion of the Engineer it is necessary or expedient for the Railway Company, that the said work or any portion of it should be stopped, or that the force employed thereon should be diminished, the Railway Company may stop such work or diminish such force, and upon being requested in writing to do so by the Railway Company, the Contractor shall stop the work or reduce the force, as the case may be, in accordance with such written request, and the Contractor shall have no claim for damages by reason thereof. Such writing shall be signed by the Engineer and delivered to the Contractor or to some person on the work representing the Contractor at least thirty days previous to such required stoppage of work or reduction of force.

Additional force.

(9) If at any time before the completion of this contract the Contractor shall not be progressing with the said work with sufficient diligence to satisfy the Engineer, or, in the opinion of the Engineer, with sufficient force to insure its progress and completion within the time or times required by this agreement, the Engineer may order and direct the Contractor to put on and employ such additional force and means as, in the judgment of the Engineer, shall be sufficient to complete the said work and each portion thereof within the specified time, and upon the refusal, failure or omission of the Contractor to comply with such order and directions within one week from the giving of the same, the Engineer may declare this contract abandoned by the Contractor, and, in that case, the moneys which may then remain unpaid, and which would otherwise be payable to the Contractor under this agreement, including the percentage

retained on all estimates, may be kept, retained and appropriated by the Railway Company, in its own right absolutely, and the Contractor shall have no claim to the said moneys or to any part thereof, and the Railway Company may employ such force and means as in the judgment of the Engineer or Engineer shall be necessary to complete said work and the cost and expenses connected therewith, and all damage suffered by the Railway Company by reason of such failure on the part of the contractor shall be charged to and be paid by the Contractor.

(10) The Contractor shall promptly pay for all labor, services or material used in or about the construction of the work, and all payments for such purposes shall be made by the Contractor at least as often as payments are made by the Railway Company to the Contractor, and, in the event of failure by the Contractor at any time to do so, the Railway Company may retain from all moneys due or to become due to the Contractor such amount of moneys as the Engineer or the Engineer may deem sufficient to pay for the same or to secure the Railway Company from loss by such non-payment. Before final settlement is made between the parties hereto for work done and materials furnished under this contract, the Contractor shall and will produce and furnish evidence satisfactory to the Railway Company that the said work and any other property of the Railway Company upon which such work may have been constructed and all structures are free and clear from all liens for labor, workmanship, materials or otherwise and that no claim then exists in respect of which a lien upon the said work or property of the Company could or might attach. And the Contractor shall protect and hold harmless the Railway Company and all its property from any and all kinds of liens accruing for labor and services performed and material furnished or otherwise and any of the same in or about the said work.

Contractor to pay for labor promptly.

Liens.

(11) The Contractor shall be at the risk of and shall bear all loss or damage whatsoever and from whatsoever cause arising which may occur on the work until the same be fully and finally completed, delivered to and accepted by the Railway Company, and if any loss or damage occur before such final completion, delivery to and acceptance by the Railway Company, the Contractor shall immediately,

Damage to work.

at his own expense, repair, restore and re-execute the work so damaged or which may have been destroyed.

Damage generally.

(12) The Contractor and his agents, laborers and all others in his employ or under his control shall use due care that no person or property is injured or any rights infringed in the prosecution of the said work, and if any damage to any person or property occurs in or about the said work or if any right is infringed without any fault or negligence on the part of the Railway Company, any damages or compensation recoverable from the Railway Company in respect thereof shall be paid by the Contractor, and together with any costs or expenses incurred in adjusting the same may be deducted by the Railway Company from any moneys due to or to become due to the Contractor.

Extension of time in case of stoppage.

(13) If there be any stoppage of the said work upon the written direction of the Railway Company, or if its progress be materially delayed by reason of any act or neglect of any of the Engineers, agents or employees of the Railway Company the time herein specified for completing the said work shall be extended for a period equal to the time of such stoppage or delay, and the Contractor shall have no further or other claim therefor, or from anything arising therefrom or caused thereby. The right of the Contractor to such extension shall be deemed to have been waived unless a claim therefor, stating the occasion and nature thereof, shall be made by him in writing delivered to the Railway Company at the time of such stoppage or delay.

Total suspension.

(14) In case of a total suspension of all work under this agreement without any fault, default, collusion, or procurement of the Contractor for a longer period than..... days, unless such suspension shall have been caused by the winter season or protracted rigor of weather, it shall be the duty of the Engineer to make a final estimate of the work done according to the terms of this agreement and to make a return thereof to the Railway Company, when the amount found by the Engineer to be then due for work done, together with all percentage retained up to that time, except as herein otherwise provided, shall be paid to the Contractor.

Damage by fire.

(15) Any damage by fire that may occur to buildings or structures during construction, must be made good by the Contractor, who must keep such structures fully insured

until the same have been completed and accepted by the Railway Company. The operation or occupation by the Railway Company of a portion of the work before the completion of the whole, is not to be considered as an acceptance of the same by the Railway Company. The premiums for fire insurance provided for herein shall be divided equally between the parties hereto and the policies are to be in the names of both parties, the loss being made payable as their interests may appear and the policy or policies shall be deposited with the.....Engineer of the Railway Company.

Insurance.

(16) In consideration of the faithful performance by the Contractor of all and singular the covenants and agreements herein contained, the Railway Company hereby covenants and agrees with the Contractor that it will well and truly pay to him on the full completion by him of all the work embraced in this agreement, in the manner and within the time herein specified and limited for the completion thereof to the satisfaction and subject to acceptance by its Engineer, and subject also as herein provided the following sums and prices, namely:.....

Ry. Co.'s covenant to pay.

.....
.....
.....
.....

(17) In addition to the foregoing contract price the Railway Company shall pay to the Contractor for extra work or for work done under written orders of the Engineer, not covered by this agreement but done in the proper execution of this contract and for which prices are not named herein, the actual cost of such work, with an additional ten per cent upon the cost of labor and material for use of tools, contractor's plant, superintendence and profit. But such actual cost shall not exceed the reasonable market value of such labor and material as the case may be.

Price for extra work.

(18) Approximate estimates of the work done under this contract are to be made at the end of each calendar month by the Engineer, and payments thereon shall be made by the Railway Company to the Contractor on or about the twentieth day of the next ensuing month, less all previous payments and less ten per cent of the amount of each and every such monthly estimate, which last mentioned per-

Approximate estimates.

centage may be retained by the Railway Company as an additional security for the performance of this contract by the Contractor until the same has been completely performed.

Final
estimate.

(19) When, in the opinion of the.....Engineer of the Railway Company this agreement has been completely performed within the time herein provided, subject to the foregoing provision as to extension, he shall certify the same in writing under his hand with a final estimate of the work done by the Contractor and a statement of the amount due and unpaid, and the Railway Company shall, within sixty days after such completion, pay to the Contractor the full amount which shall be so found due including the percentage retained on former estimates as aforesaid, except as in this agreement is otherwise provided upon delivery by the Contractor to the Company, if required, of a good and valid release and discharge of and from any and all claims and demands for and in respect of all matters and things growing out of or connected with this contract or the subject matter thereof and of and from all claims and demands whatsoever.

Alteration of
work.

(20) The right is hereby reserved by the Railway Company at any time to change and alter in whole or in part as to it may seem expedient, the works embraced in this agreement, and any change or alteration of the works shall not affect the prices herein specified, nor shall any bill for extras or other charge or claim be made, allowed or paid by reason thereof or of any difference occasioned by such change or alteration in the quality, locality or nature of the work to be performed, but if the.....Engineer shall deem the change or alteration of the works to have materially affected the cost of doing the work he shall fix or determine the price to be paid either above or below, as the case may be, the prices hereinbefore provided to be paid for such work so as to do substantial justice to both parties.

Contractor's
information.

(21) It is hereby declared and agreed to by the Contractor that this agreement is made and entered into by him for the consideration herein expressed solely on his own knowledge and upon information derived from sources other than the Railway Company, its officers or agents, of and respecting the nature and formation of the property upon which the said work is to be done, or the character, quan-

tities or location of the material required to be removed, and that the Contractor does not rely upon any information given, or statement made, to him in connection with the said contract by the Railway Company or any of its officers or agents.

(22) If the Contractor shall, at any time, fail, omit or refuse to comply with or perform any of the provisions of this agreement, which, on his part, are to be observed or performed, the Railway Company may cancel and annul this contract, in which event the Contractor shall have no claim or demand whatever upon or against the Railway Company for damages, or for compensation for work done, or material provided, or for any portion of the said percentage retained on any estimate, and the Railway Company may take possession of and hold the said work and all materials furnished under this agreement, and may retain and appropriate to its own use all moneys which may then be unpaid to the Contractor, including the said percentage, and the Railway Company shall be absolutely and forever released from all liability therefor to the Contractor.

Cancellation
of contract.

(23) In order to prevent disputes or misunderstandings between the parties hereto in relation to any of the stipulations and provisions contained in this agreement, or the true intent and meaning thereof, or the manner of performance thereof, or of any part thereof by either of the said parties, and for the speedy settlement of such as may occur, the.....Engineer for the time being of the Railway Company shall be, and he hereby is, made, constituted and appointed sole umpire to decide such questions and matters, including the amount and quantity, character and kind of work performed and materials furnished by the Contractor, and all extra work and material. The decisions of the.....Engineer, which may be given from time to time as the questions come up, shall be binding and conclusive upon both parties hereto.

Settlement
of disputes.

(24) Wherever, in this agreement, it is stipulated that anything shall be done or performed by either of the parties hereto it shall be assumed that such party has thereby entered into a covenant with the other party to do or perform the same, and that such covenant is entered into, not only by, for, or on behalf of the parties hereto, but is also entered into by and on behalf of their respective executors,

administrators, successors and assigns. And whenever this agreement is entered into by more than one person as parties of the first part the word "contractor" shall be read "contractors" and the pronouns referring to the contractor shall be read as plural; and whenever a corporation is the party of the first part the said pronouns shall be varied accordingly.

In witness whereof the parties hereto have herewith caused these present to be signed and sealed on the day and year first above written.

Signed, sealed and delivered by the
Contractor in presence of

.....
Signature of Witness.

.....
Signature of Contractor.

Signed, sealed and delivered by the
Railway Company in presence of

.....

Preparation of Plans. — By establishing a uniform practice in the making and preparation of plans, etc., the subsequent labor and investigation, including the filing and keeping of records, are simplified for all concerned.

Plan Sizes: —

Sketch plans to attach to letters, agreements, etc., 8" × 10" and 8" × 13".

Sketch plans for record books, 9" × 12" with 1" border.

Structural plans, 18" × 24" with 1" border.

Yard plans, 21" wide, length variable.

Track profiles, 11" wide, length variable.

Right of way and land plans, 21" to 30" wide, length variable.

Right of way profiles, 11" wide, length variable.

Drawing Material. — Use tracing cloth (working on dull side for all original drawings). Transparent profile paper for reference profiles. Blueprints for working plans. Vandyke prints for duplicating originals.

Working Lines. — Black full lines for all original structural work. For alterations and additions black full lines for present work, dotted black lines for work to be abandoned, full red lines for proposed new work, dotted red lines for future extension. All plans to be made to speak for themselves.

Titles. — Titles and all lettering should be very plain and eligible, without frills of any kind. Avoid notes as much as possible. All plans should be signed and dated.

Blueprints. — In making blueprints, do not, unless absolutely necessary, go over figures or lettering with red color, as this makes the figures almost illegible. It is sufficient to draw the various lines in, or to go over the edging in red.

Coloring Plans. — Satisfactory prints cannot be taken from plans which have had flat washes laid upon them. When it is necessary to use color, an edging only should be put on, and this edging should be kept just a shade from the boundary line. The boundaries will then show up clear when prints are made.

Gamboge should never be used on tracings, as it runs after being put on.

When it is necessary to put an edging of color on the blue part of a blueprint, the color will show up well if mixed with Chinese white.

Blue should not be used as an edging, except on rivers and lakes, in which case, the blue print plainly shows the edge of the water.

Colors for Progress Profiles. —

January	Sepia.	July	Indian ink.
February	Indian red.	August	Chrome yellow.
March	Neutral tint.	September	Cobalt blue.
April	Burnt sienna.	October	Vermilion.
May	Emerald green.	November	Violet carmine.
June	Carmine.	December	Hooker's green, No 1.

Scales. — Location plans, alterations to location, also plans of completed railway way: — Scale 400' to the inch. (In prairie country, scale may be 1,000' to the inch.) Profiles, horizontal, 400' to the inch; Vertical, 20' to the inch.

Station Yard Plans: Scale 100' to the inch. Show all tracks in single lines.

Railway Crossings or Junctions: Scale 100' to the inch.

Highway Crossings: Standard and general structural plans, scale $\frac{1}{8}$ " and $\frac{1}{4}$ " to the foot generally.

Details, Scale, variable.

Sketches, Scale, variable.

Railway Grade Crossings and Junctions for purposes of signal record on Diagram outlines, map be distorted so as to get in the information and to show the nature of the crossing more clearly.

Estimates.

Estimates should be prepared by the Engineer to cover the cost of the entire work complete, ready for operating.

The following summary and detailed lists will call to mind items that might otherwise be forgotten.

SUMMARY ESTIMATES.

FORM No. F. 4g.

.....RAILWAY COMPANY

ENGINEERING DEPARTMENT.

Estimate of cost of line.....to.....
 Length: Main Track.....miles; Siding, etc.....miles;
 Total.....miles. Based upon.....made.....
190.....by.....Engineer under
 direction of

Items.	Per Mile.	Total.
1. Bridges.....		
2. Buildings.....		
3. Culverts.....		
4. Crossings, Cattle Guards and Signs.....		
5. Expenses, General.....		
6. Fencing.....		
7. Grading.....		
8. Interlocking.....		
9. Masonry.....		
10. Miscellaneous.....		
11. Real Estate.....		
12. Shops.....		
13. Signals.....		
14. Structures, General.....		
15. Timber Structures.....		
16. Track Material.....		
17. Turnouts.....		
18. Tools.....		
19. Tunnels.....		
20. Trestles.....		
21. Train Service.....		
22. Telephone.....		
23. Telegraph.....		
24. Yards.....		
Expenses prior to this estimate.....		
Total Estimated Cost.....		

Remarks: —

DETAIL ESTIMATES.

FORM E. 4h

..... RAILWAY COMPANY.

ENGINEERING DEPARTMENT.

Items to be Covered when Estimating the Cost of Railroads.

Item.	@	Quantity.	Cost.	Item.	@	Quantity.	Cost.
BRIDGES.				CULVERTS.			
Deck Plate Girder Spans.....				Tile Pipe.....			
Half Plate Girder Spans.....				Concrete Pipe.....			
Through Plate Girder Spans.....				Cast-iron Pipe.....			
Deck Riveted Trusses.....				Concrete Arch.....			
Through Riveted Trusses.....				Concrete Rail.....			
Draw Deck Plate Spans.....				Steel Rails in Concrete.....			
Draw through Plate Spans.....				Stone Arch.....			
Draw Deck Riveted Spans.....				Stone Box.....			
Draw through Riveted Spans.....				Wood Box.....			
Floor System.....				Iron in Box.....			
Iron in Floor.....				Paving.....			
Guards.....				Riprap.....			
Watchman's Shanty on Draw.....				Piling.....			
Semaphores for Draw.....				Sheet Piling.....			
Signals and Lights.....				Iron in Piling.....			
False work.....				Excavation.....			
Painting.....				Filling.....			
Howe Truss Deck Spans.....				CROSSINGS, CATTLE GUARDS AND SIGNS.			
Howe Truss through Spans.....				Cattle Guards.....			
Steel and Cast Iron.....				Road Crossings.....			
BUILDINGS.				Farm Grade Crossings.....			
Boiler House.....				Farm Overhead Crossings.....			
Boiler House Equipment.....				Farm Under Crossings.....			
Bunk House.....				Public Road Gates.....			
Charcoal House.....				Electric Bell Protection.....			
Engine House.....				Watchman's Tower and Plant.....			
Engine House Equipment.....				Farm Gates.....			
Oil House.....				Sign Posts, etc.....			
Freight House.....				EXPENSES (GENERAL).			
Ice House.....				Interest and Commissions.....			
Pump House.....				Expense of Corporations.....			
Pump House Equipment.....				Expense of Railway Commission.....			
Sand House.....				Taxes, etc.....			
Shelters.....				Legal Expenses.....			
Stations.....				Clerical Expenses.....			
Station Wells.....				Engineering Expenses.....			
Furniture and Fixtures.....				Supervision and Contingencies.....			
Semaphores and Lights.....				Supplies.....			
Sheds.....				Outfits.....			
Platforms.....				Other Expenditures.....			
Storehouse.....				FENCING.			
Scrap Iron Shed.....				Wire Fence, Right of Way.....			
Thawing-out House.....				Wood Fence, Snow, etc.....			
Telegraph Office.....				Wood Fence, Yard.....			
Watchman's Shanties.....				Wood Fence, Station.....			
Tool Houses.....							
Section Houses.....							
Privies.....							
General Office Building.....							
Fixtures and Equipment.....							

DETAIL ESTIMATES — *Continued.*

Item.	@	Quantity.	Cost.	Item.	@	Quantity.	Cost.
GRADING.				SIGNALS.			
Clearing				Semaphores			
Grubbing				Mechanism			
Cutting Dangerous Trees				Lights			
Cross Waying				STRUCTURES.			
Solid Rock				Turntable and Pit			
Loose Rock				Drainage for Pit			
Excavation, Common				Ash Pit			
Excavation, Borrow Pits				Drainage for Ash Pit			
Excavation, extra haul				Coaling Plant			
Riprap				Water Tank			
Slope Walls				Water Supply			
Retaining Walls				Standpipes			
Cribs				Water Connections			
Wing Dams				Gravity Water Supply			
Tile Drains				Wind Mills			
INTERLOCKING.				Dams			
Tower				Artesian Wells			
Mechanism				Track Scales			
MASONRY.				Weigh Shelter			
Abutments				TIMBER STRUCTURES.			
Piers				Timber Abutments			
Retaining Walls				Timber Piers			
Excavation				Timber Caissons			
Filling				Timber Cribs			
Piles				Timber Cofferdams			
Sheet Piling				Timber Grillage			
Riprap				Wrought Iron			
MISCELLANEOUS.				Cast Iron			
Grain Elevators				TRACK MATERIAL, ETC.			
Storage Warehouse				Rails			
Storage, Freight				Splices			
Storage, Cold				Bolts and Nuts			
Dock and Wharves				Spikes			
Miscellaneous Structures				Tie Plates			
Coal Storage Plant				Rail Braces			
REAL ESTATE.				Anti Creepers			
Right of Way				Ties			
Station Grounds				Ballast			
Terminal Grounds				Track Laying			
Damages to Property				Surfacing			
Mining Claims				TURNOUTS.			
SHOPS.				Stub Switch Turnouts			
Blacksmith Shop				Split Switch Turnouts			
Car Repair Shop				Slip Switch Turnouts			
Transfer Table and Pit				Cross Overs			
Service Truck Pits				Diamond Crossings			
Service Truck Turntables				Switch Ties			
Miscellaneous Buildings				TOOLS.			
Machinery and Tools				Track Tools			
Equipment and Fixtures							
Power House							

DETAIL ESTIMATES — *Continued.*

Item.	@	Quantity.	Cost.	Item.	@	Quantity.	Cost.
TUNNELS.				TRAIN SERVICE.			
Excavation, Rock Section				Raising Sags, etc.			
Excavation, Timber Section				Filling Trestles, etc.			
Excavation, Extra Section				Widening and Filling Banks			
Timber Lining and Portals				General Service			
Masonry Lining and Portals				Transportation			
Ventilation				Freight			
Drainage				TELEPHONE.			
TRESTLES.				Telephone Service			
Pile Trestle				Equipment			
Frame Trestle				TELEGRAPH.			
Steel Trestle				Poles and Wires			
Excavation				Erection			
Masonry Foundations				Installation			
Cedar Sill Foundations				YARDS.			
Pile Foundation				Trackage			
Wrought Iron				Lighting			
Cast Iron				Fire Service			
Floor System				Water Service			
Guards				Steam, Air and Gas			
Fastenings				Utility Buildings			
Fire Protection							
Signals							

CHAPTER IX.

ESTIMATING NOTES.

Foundations.

Excavation. — Excavation consists in digging out the ground to such depths as may be necessary for the foundations and depositing the same where directed and removing the surplus material off the premises. Excavation is paid for by the cubic yard, measurement made in excavation only.

Approximate average cost. — 50 cents per cubic yard for ordinary ground to 5 feet in depth.

Back Fill. — Back filling consists in replacing and compacting the ground around trenches after the walls are in place, and is usually paid for by the cubic yard. The same quantities allowed for excavation are usually estimated for back fill.

Approximate average cost. — For ordinary back fill 10 cents per cubic yard.

Labor. — A good laborer will dig and throw into barrow in a day of 10 hours: —

Ordinary ground	from 8 to 10 cubic yards.
Stiff clay or firm gravel	from 5 to 6 cubic yards.
Hard ground (pick work)	from 3 to 5-cubic yards.

Weights, etc., of Material. —

27 cubic feet	one load.
20 cubic feet sand	2000 pounds.
22 cubic feet coarse gravel	2000 pounds.
25 cubic feet stiff clay	2000 pounds.
28 cubic feet chalk	2000 pounds.
30 cubic feet earth	2000 pounds.

Safe Bearing Power of Various Soils. —

	Tons per sq. ft.
Soft clay	1
Dry clay in thick beds	4
Ordinary clay and sand together in layers, wet	2
Loam, clay, or fine sand, firm and dry	3
Very fine, coarse sand, stiff gravel, or hard clay	4
Solid rock will sustain load which can be put upon it.	

Masonry.

Masonry is estimated and paid for generally by the cubic yard, measured in place. The price is held to cover all material and labor.

Approximate average cost.

Dry rubble masonry.....	\$ 3.75 per cubic yard.
Rubble masonry.....	7.00 per cubic yard.
Rock-faced masonry.....	12.00 per cubic yard.

Dry Rubble Masonry. — Dry rubble walls consist of good quarry stone laid dry upon the natural beds and roughly squared on joints, beds, and faces.

Rubble Masonry. — Rubble walls are built of stone roughly squared and laid in irregular courses, having all voids in the heart of the wall thoroughly filled with suitable stone and spalls fully bedded in cement mortar. Face joints not more than 1 inch thick.

Rock-faced Ashlar. — Rock-faced ashlar is generally designated first-class masonry, and consists of large and well-proportioned stone built in regular courses, with backing of well-shaped and large-sized stone roughly bedded and jointed, with all voids thoroughly filled with spalls, fully bedded in cement mortar, with coping stones, chamfers, and arrises neatly chisel dressed.

Approximate cost of rubble masonry per cubic yard, using 1 to 3 Portland cement mortar.

1 cubic yard stone delivered.....	\$1.25
$\frac{1}{2}$ barrel cement at \$2.60	1.30
$\frac{1}{2}$ load sand at \$1.....	.35
$\frac{1}{2}$ day's mason labor at \$3.30.....	1.10
$\frac{1}{2}$ day's helper at \$1.50.....	.50
	<hr/>
	\$4.50

Cut stone pier caps per cubic foot \$1.75 to \$2.25.

Coffer-Dams. — Coffer-dams of timber are constructed so as to permit of the water being pumped out and the foundations laid dry, and is usually measured and paid for by the thousand feet board measure, the price to include all labor and material.

Approximate cost per thousand feet board measure, \$40.

Cement. — A barrel of American hydraulic cement weighs on an average 300 pounds net and contains 3.6 cubic feet.

A barrel of Portland cement weighs on an average 380 pounds net and contains 3.8 cubic feet, or 110 pounds per cubic foot.

A bag contains 95 pounds, or four bags to the barrel.

Concrete. — Concrete is usually paid for by the cubic yard measured in place.

For one, three, and six concrete, one cubic yard requires one barrel cement, 1 cubic yard stone two and one-half inches, one-half cubic yard sand.

Approximate cost of a cubic yard.

1 barrel cement.....	\$2.60
$\frac{1}{2}$ load sand at \$1 per load.....	.34
1 cubic yard broken stone at \$1.25.....	1.25
1 laborer 1 day.....	1.50
1 helper $\frac{1}{2}$ day at \$1.....	.50
Total.....	<u>\$6.19</u>

Piling.

Piles may be of oak, rock elm, Douglas fir, tamarack, cedar, or other approved timber, reasonably straight grained, sound, and free from defects.

Standard dimensions for piling are as follows:

Minimum length in feet	15, 20, 25, 30, 35, 40, 45, 50, over 50
Diameter in inches at small end	10, 9, 9, 9, 9, 9, 8, 8, over $7\frac{1}{2}$

Butt diameter to be not less than 10 inches or more than 20 inches at five feet from butt. All diameters measured inside the bark.

Piles are generally sharpened and driven with the small end down, and capped when necessary with a suitable iron ring to prevent spreading or brooming while driving, and, if required, are shod with an iron shoe.

Piles for bridges are driven until the fall of a hammer weighing 2000 pounds, with a clear fall of 25 feet or an equivalent blow, causes a penetration not to exceed 10 inches under the last ten blows, or to such further limit as may be directed.

$$\text{Eng. formula. } P = \frac{2WH}{S+1}.$$

P = Safe load on pile in tons. H = Distance of free fall of hammer in feet.
 W = Weight of hammer in tons. S = Penetration of pile for last blow in inches.

Piling broken in the driving is pulled out and another sound pile is driven in its place.

Piles are driven vertically, unless otherwise shown on the plan. Batter piles are preferably driven at the batter shown on the plans or at a part of that batter, and then sprung over to proper position; no sawing of piles to make them spring should be allowed.

When necessary to drive a great depth and piles of adequate length cannot be obtained, one is spliced on top of another. The first pile having been driven as far as practicable, it is cut off square to receive the following pile, which also must be squared and set on top of the one already driven. The piles are then squared on four sides and fastened together by spiking on pieces of scantling.

Piling is usually paid for under the heads of "Piling delivered" and "Piling driven."

"Piling delivered" includes piling furnished by the contractor as ordered by the engineer, and is paid for by the lineal foot. Approximate average cost, 15 cents per foot.

"Piling driven" is paid for at a specified rate per lineal foot in the finished structure, and includes all work of any kind in connection therewith. Approximate average cost, 10 to 15 cents per foot.

The average cost of piling in place, including all labor and material, is 25 cents per foot.

Rings are not usually paid for, but shoes are paid for at a specified rate per shoe.

Sheet Piling.

Sheet piles are cut at the end, so as to form a point at one side and not in the middle, and when driven, this point is kept next to the pile previously driven to insure contact.

Where there are two or more rows of sheet piles they are driven with broken joints.

Sheet piling is paid for at a specified price per thousand feet board measure left in the work. Approximate cost, \$35 per thousand feet board measure.

R riprapping.

When required or ordered as protection against the action of water, riprapping is laid or placed on embankments, or about foundations, or at the ends of culverts or masonry piers or other places.

The largest procurable stones are used, and the heaviest placed at the bottom where the current is greatest. They are laid as closely together as possible to avoid large openings.

When required, a trench is excavated at the base of the slope to such depth as will insure a solid foundation.

R riprapping is paid for at a specified rate per cubic yard in place.

Approximate cost, \$1.25 per cubic yard (rough). Approximate cost, \$3 per cubic yard (hand laid).

Paving.

The ends of masonry or concrete culverts, vitrified, concrete or iron pipe, the bottom of wooden culverts, and other places are protected by paving when desired.

The paving is made of flat stones set upon their edges, the longest dimensions at right angles to the waterway, in such manner as to leave the least possible space between them, and of such size as to reach through the entire depth of the paving.

Great care must be taken at the ends of any piece of paving to make it secure, so it cannot be undermined or cut by water flowing underneath it. The lower end must receive special care to prevent this undermining.

Paving is usually paid for at a specified rate per square or cubic yard.

Approximate cost, \$1.50 per square yard.

Brickwork.

Brickwork is usually measured and paid for by the 1000 (M) bricks laid in the wall, and sometimes by the cubic yard (assume 550 bricks per cubic yard for estimating).

Size of Brick. — Common vary from $7\frac{3}{4}'' \times 3\frac{3}{4}'' \times 2\frac{1}{4}''$ to $8\frac{1}{2}'' \times 4\frac{1}{2}'' \times 2\frac{1}{2}''$; pressed brick, $8\frac{1}{4}'' \times 4'' \times 2\frac{1}{4}''$ (standard).

ONE DAY'S WORK OF BRICKLAYER AND LABORER.

Bricklayer. — High-class work, 200 to 400 bricks; house fronts, 800 to 1000 bricks; ordinary work, 1000 to 1200 bricks.

Laborer. — A good man will mix mortar and carry it and bricks for three bricklayers if mortar and brick are not more than 25 feet from the building and he does not have to carry water or climb a ladder. After ascertaining the cost of laying 1000 bricks for the first story add 5 per cent for second story, 12½ per cent for third story, and a corresponding percentage for the work laid in higher stories.

Mortar required to lay 1000 bricks: Joints $\frac{1}{4}$ to $\frac{3}{8}$ inch thick, 4 to 5 cubic feet; joints $\frac{1}{2}$ inch thick, 1½ to 2 cubic feet.

Approximate cost of common brickwork per thousand brick, using 1 to 3 lime mortar:

1000 brick.....	\$8.00
3 bushels lump lime at 25 cts.....	.75
$\frac{1}{2}$ cubic yard sand at \$1.....	.50
1 day bricklayer.....	3.50
1 day laborer.....	1.50
	<hr/>
	\$14.25

Approximate cost of common brickwork per thousand, using 1 to 3 Portland cement mortar:

1000 brick.....	\$8.00
1½ barrels Portland cement, \$2.60.....	3.90
$\frac{1}{2}$ load sand at \$1.....	.50
1 day bricklayer.....	3.50
1 day laborer.....	1.50
	<hr/>
	\$17.40

Steel and Iron Work.

The steel and iron work is usually fabricated in the shops and bought and paid for by the pound, either delivered on the works or erected complete.

The weight of steel frames for shops and similar buildings is from five to ten pounds per square foot of exposed wall and roof surface.

When provision has to be made for traveling cranes add 100 pounds per lineal foot of building for each five tons in crane capacity.

Approximate unit cost.

Steel trusses, frames, and columns in place.	3½ to 4½ cts. per pound.
Steel beams in place.....	3 to 3½ cts. per pound.
Plain castings in place.....	2½ to 3 cts. per pound.
Corrugated iron No. 22 (black) in place....	7 to 9 cts. per square foot.
Corrugated iron No. 22 (galvanized) in place	9 to 12 cts. per square foot.
Galvanized iron flashing in place.....	15 to 25 cts. per square foot.
Stairs, iron, 3 feet wide, in place.....	\$7 to \$10 each.
Steel shutters, rolling, in place.....	75 cts. to \$1.50 per square foot.
Corrugated shutters, rolling, in place.....	50 cts. to \$1 per square foot.
Netting, wire, galvanized, in place.....	40 to 60 cts. per square foot.
Railing, pipe, in place.....	75 cts. to \$1 per lineal foot.

Steel and Concrete Building.

Steel Skeleton and Concrete Construction. — Twenty pounds steel for each square foot of floor. One and one-half pounds steel for each square foot of floor for reinforcing concrete slabs.

Concrete averages 7 inches thick per square foot of floor, which will include fireproofing of columns, beams, and floor slabs.

Forms. — Two feet board measure timber per square foot to do the form work for fireproofing.

Approximate cost.

Steel erected and painted.....	\$75.00 to \$100.00 per ton.
Concrete erected.....	45 cts. per cubic foot.
Lumber erected.....	\$60.00 per 1000 ft. B. M.
Total cost: — \$1.19 to \$1.25 per square foot steel skeleton and fireproofing.	

Reinforced Concrete Construction. — Seven pounds steel per square foot of floor. Eight cubic feet concrete per square foot of floor. Lumber, 3½ feet board measure per square foot of floor.

Approximate cost.

Steel erected in place.....	\$65.00 per ton.
Concrete per cubic foot.....	60 cts.
Lumber.....	\$70.00 per 1000 feet B.M.
Reinforced concrete skeleton = 88 cts. to \$1.25 per square foot.	

Reinforced concrete partition costs about 30 cts. per square foot more than a hollow plaster partition.

Building face walls, reinforced concrete:

Concrete placed.....	\$ 5.50 per yard.
Forms and carpentry work.....	10.00
Runways and scaffolding.....	5.50
Reinforcement.....	.65
Total cost.....	\$21.65 per yard in place.

Reinforced concrete retaining walls.....	\$12.00 per yard in place.
Concrete retaining walls.....	7.50 per yard in place.
Concrete trestle piers.....	7.00 per yard in place.
Engine and hammer foundations.....	6.00 to \$7.00 per yard.

Paint.

Some railroads have their own standard color cards stating the shades to be adopted on the various structures.

Ready-mixed paints are generally used.

The cost of paint varies from \$1.25 to \$1.75 per gallon. One gallon of paint will cover 50 square yards first coat. One gallon of paint will cover 60 square yards second coat. One gallon of paint will cover 75 square yards third coat. The labor is about equivalent to the cost of the material.

Timber.

It is generally designated that all timber shall be well seasoned and reasonably free from knots, shakes, waness, etc., and free from sap or other imperfections.

Average weight per cubic foot, 40 pounds.

TABLE 54. — AVERAGE ULTIMATE BREAKING UNIT STRESSES IN POUNDS PER SQUARE INCH.

Recommended by the Committee on "Strength of Bridge and Trestle Timbers," American Association of Railway Superintendents Bridges and Buildings, 5th Annual Convention, New Orleans, October, 1895.

Kind of timber.	Tension.		Compression.			Transverse rupture.		Shearing.	
	With grain.	Across grain.	With grain.		Across grain.	Extreme fiber stress.	Modulus of elasticity.	With grain.	Across grain.
			End Bearing.	Columns under 15 diams.					
White oak.....	10,000	2000	7000	4500	2000	6000	1,100,000	800	4000
White pine.....	7,000	500	5500	3500	800	4000	1,000,000	400	2000
Southern long-leaf or Georgia yellow pine.....	12,000	600	8000	5000	1400	7000	1,700,000	600	5000
Douglas, Oregon, and Wash- } ington fir or pine } red fir.....	10,000	8000	6000	1200	6500	1,400,000	600
Northern or short-leaf yellow pine.....	9,000	500	6000	4000	1000	6000	1,200,000	400	4000
Red pine.....	9,000	500	6000	4000	800	5000	1,200,000
Norway pine.....	8,000	6000	4000	800	4000	1,200,000
Canadian (Ottawa) white pine.....	10,000	5000	350
Canadian (Ontario) red pine.....	10,000	5000	400
Spruce and Eastern fir.....	8,000	500	6000	4000	700	5000	1,400,000	400	3000
Hemlock.....	6,000	6000	4000	600	3500	900,000	400	2500
Cypress.....	6,000	6000	4000	700	5000	900,000	350
Cedar.....	8,000	6000	4000	700	5000	700,000	1500
Chestnut.....	9,000	5000	900	5000	1,000,000	600	1500
California redwood.....	7,000	4000	800	4500	700,000	400
California spruce.....	4000	5000	1,200,000

TABLE 55.—AVERAGE SAFE ALLOWABLE WORKING UNIT STRESSES IN POUNDS PER SQUARE INCH.

Kind of timber.	Tension.		Compression.			Transverse rupture.		Shearing.	
	With grain.	Across grain.	With grain.		Across grain.	Extreme fiber stress.	Modulus of elasticity.	With grain.	Across grain.
			End bearing.	Columns under 15 diams.					
	Ten.	Ten.	Five.	Five.	Four.	Six.	Two.	Four.	Four.
Factor of safety.									
White oak.....	1000	200	1400	900	500	1000	550,000	200	1000
White pine.....	700	50	1100	700	200	700	500,000	100	500
Southern long-leaf or Georgia yellow pine	1200	60	1600	1000	350	1200	850,000	150	1250
Douglas, Oregon, and Wash- } yellow fir...	1200		1600	1200	300	1100	700,000	150	
ington fir or pine	1000					800			
Northern or short-leaf yellow pine.....	900	50	1200	800	250	1000	600,000	100	1000
Red pine.....	900	50	1200	800	200	800	600,000		
Norway pine.....	800		1200	800	200	700	600,000		
Canadian (Ottawa) white pine.....	1000			1000				100	
Canadian (Ontario) red pine.....	1000			1000				100	
Spruce and Eastern fir.....	800	50	1200	800	200	800	700,000	100	
Hemlock.....	600							100	
Cypress.....	600							100	
Cedar.....	800		1200	800	150	700	600,000	100	750
Chestnut.....	900		1200	800	200	800	450,000	100	600
California redwood.....	700			1000	250	800	350,000		400
California spruce.....				800	200	750	500,000	150	400
				800		800	350,000	100	
							600,000		

Wooden Beams.

TABLE 56.—VALUES OF I (MOMENT OF INERTIA) AND S (SECTION MODULUS).

Size, breadth by depth, inches.	Moment of inertia, $\frac{1}{12} b d^3$.	Section modu- lus, $I \div \frac{1}{2} d$.	Size, breadth by depth, inches.	Moment of inertia, $\frac{1}{12} b^3 d$.	Section modu- lus, $I \div \frac{1}{2} d$.
2×2	6×6	108.00	36.00
2×3	4.50	3.00	6×7	171.50	49.00
2×4	10.66	5.33	6×8	256.00	64.00
2×5	20.83	8.33	6×9	364.50	81.00
2×6	36.00	12.00	6×10	500.00	100.00
2×7	57.16	16.33	6×11	665.50	121.00
2×8	85.33	21.33	6×12	864.00	144.00
2×9	121.50	27.00	6×13	1098.50	169.00
2×10	166.66	33.33	6×14	1372.00	196.00
2×11	221.83	40.33	6×15	1687.50	225.00
2×12	288.00	48.00	6×16	2048.00	256.00
3×3	6.75	4.50	6×17	2456.50	289.00
3×4	16.00	8.00	6×18	2916.00	324.00
3×5	31.25	12.50	7×7	200.08	57.16
3×6	54.00	18.00	7×8	288.66	74.66
3×7	85.75	24.50	7×9	425.25	94.50
3×8	128.00	32.00	7×10	583.33	116.66
3×9	182.25	40.50	7×11	776.41	141.16
3×10	250.00	50.00	7×12	1008.00	168.00
3×11	332.75	60.50	7×13	1281.58	197.17
3×12	432.00	72.00	7×14	1600.66	228.66
3×13	549.25	84.50	7×15	1968.75	262.50
3×14	686.00	98.00	7×16	2389.33	298.66
4×4	21.33	10.66	7×17	2865.91	337.17
4×5	41.66	16.66	7×18	3402.00	378.00
4×6	72.00	24.00	8×8	341.33	85.33
4×7	114.33	32.66	8×9	486.00	108.00
4×8	170.66	42.66	8×10	666.66	133.33
4×9	243.00	54.00	8×11	887.33	161.33
4×10	333.33	66.66	8×12	1152.00	192.00
4×11	443.66	80.66	8×13	1464.66	225.33
4×12	576.00	96.00	8×14	1829.33	261.33
4×13	732.33	112.66	8×15	2250.00	300.00
4×14	914.66	130.66	8×16	2730.67	341.33
4×15	1125.00	150.00	8×17	3275.33	385.33
4×16	1365.33	170.66	8×18	3888.00	432.00
5×5	52.08	20.83	9×9	546.75	121.50
5×6	90.00	30.00	9×10	750.00	150.00
5×7	142.91	40.83	9×11	998.25	181.50
5×8	213.33	53.33	9×12	1296.00	216.00
5×9	303.75	67.50	9×13	1647.75	253.50
5×10	416.66	83.33	9×14	2058.00	294.00
5×11	554.58	100.83	9×15	2531.25	337.50
5×12	720.00	120.00	9×16	3072.00	384.00
5×13	915.41	140.83	9×17	3684.75	433.50
5×14	1143.33	163.33	9×18	4374.00	486.00
5×15	1406.25	187.50			
5×16	1706.66	213.33			

TABLE 56. — *Continued.*

Size, breadth by depth, inches.	Moment of inertia, $\frac{1}{12} bd^3$.	Section modu- lus, $I \div \frac{1}{2} d$.	Size, breadth by depth, inches.	Moment of inertia, $\frac{1}{12} bd^3$.	Section modu- lus, $I \div \frac{1}{2} d$.
10×10	833.33	166.66	11×14	2515.33	359.33
10×11	1109.17	201.67	11×15	3093.75	412.50
10×12	1440.00	240.00	11×16	3754.67	469.33
10×13	1830.83	281.67	11×17	4503.58	529.83
10×14	2286.66	326.67	11×18	5346.00	594.00
10×15	2812.50	375.00			
10×16	3413.33	426.27	12×12	1728	288
10×17	4094.17	481.67	12×13	2197	388
10×18	4860.00	540.00	12×14	2744	392
			12×15	3375	450
11×11	1220.08	221.83	12×16	4096	512
11×12	1584.00	264.00	12×17	4913	578
11×13	2013.92	309.84	12×18	5832	648

Carpentry.

Carpentry includes all of the rough lumber such as the framing and covering, studding, sheathing, flooring, siding, posts and beams, plaster grounds, bridging, etc.

Joinery includes all the exterior and interior finish after the carpentry work is done, such as window frames, doors, sashes, bases, architraves, paneling, wainscoting, stairs, etc., most of which is obtained from the mill, and is often termed the mill work.

Board Measure. — One foot board measure (B. M.) is equal to one foot square and one inch thick. Lumber is usually measured and sold by the thousand (M) feet board measure (B. M.).

Example. — The number of feet board measure in a plank $3'' \times 12'' \times 24'$ long = 24 square feet $\times 3'' = 72$ feet B. M.

Approximate cost of 1000 feet B. M. lumber:

1000 feet lumber.....	\$18.00
Nails and spikes, 33 pounds at 3 cts.....	1.00
Labor (50% cost of material).....	9.00
Cost per M feet B. M.....	\$28.00
Spruce lumber in place on floor or roof, per M.....	30.00
Pine matched in place on floor or roof, per M.....	40.00
Pine joist and purlins on roof or floor, per M.....	35.00

Joinery is usually estimated by the running or square foot.

Approximate cost of joinery:

- Door frames and doors in place, 50 cents per square foot.
 Window frames and sash in place, 50 cents per square foot.
 Sash glazed and painted, 20 to 30 cents per square foot.
 Louver ventilators, fixed, 50 to 75 cents per square foot.
 Louver ventilators, moving, 75 cents to \$1 per square foot.
 Stairs in place, \$3 per step 3 feet long.
 Picture molding, 5 cents per lineal foot.
 Winter sash and frame, 30 cents per square foot.

Roofing, etc.

Roofing is usually measured and paid for by the square of 100 square feet (10 feet by 10 feet).

Tar and Gravel. — Ordinary 3-ply on 1-inch boards weighs about 10 pounds per square foot. Trinidad pitch averages $3\frac{1}{2}$ gallons per square. Gravel washed averages 350 pounds per square, or 3 cubic feet. Roofing cement averages 100 pounds per square.

Slate. — Ordinary slate on 1-inch boards weighs about 14 pounds per square foot. Laid 7 inches to the weather $10'' \times 20''$ slates = 210 slates per square; 420 roofing nails $1\frac{3}{8}$ inches long, or $1\frac{1}{2}$ pounds per square. Laid $8\frac{1}{2}$ inches to the weather $10'' \times 20''$ slates = 180 slates per square; 360 roofing nails $1\frac{3}{8}$ inches long, or $1\frac{1}{4}$ pounds per square.

Gutter and conductor in place.....	25 to 50 cts. per lineal foot.
Skylights, $\frac{1}{4}$ inch thick glass	25 cts. per square foot.
Skylights, translucent fabric.....	20 cts. per square foot.
Round ventilators, fixed.....	\$10.00 to \$15.00 each.
Round ventilators, revolving.....	30.00 to 50.00 each.
Slate roof, not including boards	7.00 to 12.00 per square.
Slag and gravel roof, not including boards ..	4.00 to 5.00 per square.
Prepared composition roof, not including boards.....	2.00 to 3.00 per square.
Wood shingle roof, not including boards	3.00 to 5.00 per square.
Tin-plate roof, not including boards.....	7.00 to 12.00 per square.
Corrugated iron roof, not including boards ..	7.00 to 10.00 per square.

Shingles. — Shingles are usually measured and paid for by the square of 100 square feet ($10' \times 10'$) and are commonly laid 4, $4\frac{1}{2}$, and 5 inches to the weather.

Size generally 4 inches wide by 18 inches to 20 inches long.

Approximate number required per square (100 square feet):

Four inches to the weather, 900; $4\frac{1}{2}$ inches to the weather, 800; 5 inches to the weather, 725.

The bottom row is always doubled, and to the above should be added 5 per cent to 10 per cent to allow for this, and to include waste and cutting at dormers, ridges, etc.

All shingles which are seasoned should be laid one-fourth to three-eighths inch apart so as to allow room for swelling during wet weather.

Green shingles should be laid almost close together.

Shingle nails $1\frac{1}{8}$ inches long, use one-half pound per 100 shingles.

Plaster.

Plastering is usually measured and paid for by the square yard; cornices and moldings by the running foot and an extra price for each miter.

Two-coat work requires for 100 yards plastering 1400 laths, $4\frac{1}{2}$ bushels of lime, four-fifths of a cubic yard of sand, 9 pounds of hair, and 5 pounds of nails.

Three men and one helper will put on 450 yards in a day's work of two-coat work, and will put on a hard finish for 300 yards.

A load of mortar measures one cubic yard, requires one cubic yard of sand and nine bushels of lime, and will fill 30 hods.

A bushel of hair weighs, when dry, about 15 pounds.

INDEX.

	PAGE		PAGE
A			
Abutments —		Buildings — <i>continued</i>	
bridge.....	61	car truck.....	211
crib.....	83	dry kilns.....	211
Air plant, cold.....	142	engine houses.....	108
Angle bars.....	6	foundry.....	212
Arch culverts.....	48	freight.....	212
Artificial ice making.....	138	frog.....	213
Ash pits.....	157	ice houses.....	135
B		locomotive.....	213
Back fill.....	249	oil houses.....	132
Balanced bucket coaling plant.....	149	passenger.....	214
Ballasting.....	11	pattern.....	215
Ballast sections.....	14	planing mill.....	215
Bars, angle.....	6	power house.....	215
Belt conveyer.....	149	pump houses.....	196
Blacksmith shop.....	210	sand houses.....	162
Boat spikes.....	9	section houses.....	92
Boilers.....	182	storehouses.....	129
Boiler houses.....	127	stores.....	217
Bolts and nuts, track.....	6	tool houses.....	87
Box culverts.....	52	wheel foundry.....	217
Braces, rail.....	13	C	
Brickwork.....	253	Cabinet shop.....	210
Bridge —		Cable railway.....	154
abutments.....	61	Capacity of pumps.....	186
dead load.....	55	Car machine shop.....	211
live load.....	55	Carpentry.....	260
piers.....	63	Car truck shop.....	211
Bridges —		Cast-iron pipe culverts.....	47
deck plate.....	53	Cattle guards.....	41
deck trusses.....	54	Cedar box culverts.....	52
draw.....	54	Cement.....	250
half deck plate.....	53	Cinder ballasting.....	11
through trusses.....	54	Clearance posts.....	37
Bridge warning.....	38	Clearing.....	16
Buildings —		Coaling stations.....	144
blacksmith.....	210	Coal storage.....	154
boiler houses.....	127	Coffer-dams.....	250
cabinet.....	210	Cold air refrigeration.....	140
car machine.....	211	Cold storage.....	140

	PAGE		PAGE
Concrete.....	251	Cost of — <i>continued</i>	
Concrete arch culverts.....	47	laying and surfacing.....	23
Concrete pipe culverts.....	46	loose rock.....	15
Contracts.....	228	mail cranes.....	39
Conveyor, belt.....	149	masonry.....	250
Cost of —		oil houses.....	132
ash pits.....	157	overhaul.....	15
ballasting.....	11	overhead bridges.....	73
boiler houses.....	127	paint.....	256
boilers.....	178	paving.....	106, 253
bolts and nuts.....	7	piling.....	251
brickwork.....	253	pipes.....	184
carpentry.....	260	plaster.....	262
cast-iron pipe culverts.....	47	platform shelters.....	97
cattle guards.....	41	platforms.....	103
cedar box culverts.....	52	privies.....	94
clearing.....	16	pump houses.....	196
coaling stations.....	144	pumps.....	178
cold air plant.....	142	pumping water.....	179
cold storage.....	142	rail braces.....	13
concrete.....	251	rail concrete culverts.....	50
concrete arch culverts.....	48	rail joints.....	6
concrete pipe culverts.....	46	rails.....	4
cranes.....	209	retaining walls.....	80
crib abutments.....	83	riprapping.....	253
cribs.....	82	roofing.....	261
crossovers.....	23	sand houses.....	162
crosswaying.....	15	section houses.....	92
dams.....	205	shelter stations.....	96
deck plate bridges.....	56	shops.....	208
deck trusses.....	58	sign boards and posts.....	35
diamond crossing.....	25	snow sheds.....	170
drawbridges.....	60	solid rock.....	15
engine houses.....	108	spikes.....	9
equipment.....	208	standpipes.....	201
farm crossings.....	40	stands, lamps, rods, etc.....	22
fencing.....	26	station furniture.....	102
foundations.....	249	stations.....	98
freight sheds.....	104	steam, air, and water pipes.....	119
frogs.....	22	steel and concrete.....	255
gates.....	30	steel and iron work.....	254
grade crossings.....	40	steel trestles.....	70
grading.....	15	stock yards.....	167
grubbing.....	16	stone box culverts.....	51
half deck plate bridges.....	75	storehouses.....	129
heating engine houses.....	120	subways.....	75
highway alarm bell.....	34	surfacing.....	11
Howe truss bridges.....	71	switches.....	22
ice houses.....	135	switch ties.....	21
ice making.....	138	tanks.....	199
interlocking.....	25	through trusses.....	59

	PAGE		PAGE
Fastenings —		Highway — <i>continued</i>	
bolts and nuts.....	6	crossings.....	73
splices.....	5	Horsepower, water.....	192
spikes.....	8	Houses —	
track.....	5	boiler.....	127
Fence —		cold storage.....	142
close board.....	28	engine.....	108
field-erected wire.....	27	freight.....	104
open board.....	29	ice.....	135
picket.....	28	oil.....	132
portable.....	29	privies.....	94
snow.....	28	pump.....	196
wire.....	26	sand.....	162
woven-wire.....	27	section.....	92
Flanger post.....	35	station.....	98
Forms.....	219	storehouses.....	129
Foundations.....	249	tank.....	197
Foundry shop.....	212	tool.....	87
Frame trestles.....	66	watchman's.....	91
Freight —		Howe trusses.....	71
car shop.....	212		
platforms.....	103	I	
sheds.....	104	Ice houses.....	135
Friction water.....	190	Ice making.....	138
Frogs.....	18	Ice plant.....	142
Frog shop.....	213	Interlocking plant.....	25
Furniture, station.....	102		
		J	
G		Jacks, smoke.....	115
Gates —		Jib crane and buckets.....	144
crossing.....	30	Joints —	
steel.....	34	lead and yarn.....	46
wood.....	33	mortar.....	45
Grade crossings.....	39	Jordan guard.....	76
Grading.....	15		
Grain loading platforms.....	103	L	
Gravel —		Lamps, switch.....	22
ballasting.....	11	Lap switch.....	17
loading.....	11	Laying and surfacing track....	11
Grubbing.....	16	Live load (bridges).....	55
Guards —		Locomotive —	
bridge and trestle.....	76	crane.....	151
cattle.....	41	shop.....	213
		turntables.....	172
H			
Half deck plate bridges.....	53	M	
Hand shoveling, coal.....	144	Mail crane.....	39
Heating engine houses.....	120	Maintenance interlocking plant	25
Highway —		Masonry, cost of.....	80, 250
alarm bell crossing.....	34	Masonry retaining walls.....	78

	PAGE		PAGE
R			
Rail —		Single track coaling plant.....	145
braces.....	13	Slip switch.....	18
concrete culverts.....	50	Slow signal post.....	38
joints.....	6	Smoke jacks.....	115
rack.....	38	Snow —	
Rails.....	3	fence.....	28
Railway —		sheds.....	170
cable.....	154	Specifications.....	219
crossing signs.....	35	Spikes —	
Refrigeration.....	140	boat.....	9
Reinforced concrete.....	255	shimming.....	8
Retaining walls.....	78	track.....	8
Right of way fences.....	26	Splices, track rail.....	5
Riprapping.....	253	Split switch.....	17
Rock-faced ashlar.....	250	Standard tool houses.....	89
Roofing.....	261	Standpipes.....	201
Rubble masonry.....	250	Stands, switch.....	18
S			
Safe bearing of soils.....	249	Station furniture.....	102
Safety crossing gates.....	30	Station mile board.....	36
Sand houses.....	162	Stations.....	98
Scales, track.....	165	coal.....	144
Section —		water.....	174
houses.....	92	Steam, air, and water pipes... .	117
post.....	36	Steam cranes.....	209
Sections, ballast.....	14	Steel and concrete.....	255
Shallow ash pit.....	157	Steel and iron work.....	254
Sheds, freight.....	104	Steel —	
Sheet piling.....	252	gate.....	34
Shelter —		trestles.....	70
station.....	96	Stock yards.....	167
watchman's.....	91	Stone box culverts.....	51
Shops —		Stop signal post.....	38
blacksmith.....	210	Storage, cold.....	140
cabinet.....	210	Stores, shop.....	217
car machine.....	211	Storehouses.....	129
car truck.....	211	Stub switch.....	18
dry kiln.....	211	Subways.....	73
foundry.....	212	Surfacing.....	11
freight car.....	212	Swing board gate.....	33
frog.....	213	Swing wire gate.....	33
locomotive.....	213	Switch ties.....	24
passenger car.....	214	Switches.....	17
pattern.....	214	T	
power.....	214	Tanks —	
stores.....	217	track.....	206
wheel foundry.....	217	water.....	197
Shop traveling cranes.....	209	Telephone (shops).....	208
Sign boards and posts.....	35	Through trusses.....	54
		Tile drains.....	15
		Tie plates.....	12

	PAGE		PAGE
Ties —		Table No. — <i>continued</i>	
switch	24	11. Fencing per mile	26, 27
track	10	12. Safety gates	31
Tile drains	15	13. Length culvert pipes....	43
Tile pipe culverts.....	44	14. Capacity of pipes.....	44
Timber.....	256	15. Cost tile pipe.....	44
Timber trestles.....	68	16. Mortar for pipe joints...	45
Tool —		17. Cost of concrete pipes...	46
equipment.....	90	18. Lead and yarn for pipe	
houses.....	87	joints.....	46
Towers, coal.....	154	18a. Cost cast iron pipe.....	47
Track —		19. Cost concrete arch cul-	
bolts.....	6	verts.....	48, 49
rail.....	3	20. Cost rail concrete cul-	
splices.....	5	verts.....	50
Track above subgrade.....	13	21. Cost stone box culverts..	51
Track laying.....	12	22. Cost cedar box culverts..	52
Track scales.....	165	23. Weight and cost deck	
Traveling bridge, coal.....	155	plate girders.....	56
Traveling cranes.....	209	24. Weight and cost half	
Trees, removed.....	16	deck plate girders....	57
Trespass sign.....	37	25. Weight and cost deck	
Trestles —		trusses.....	58
steel.....	70	26. Weight and cost through	
timber.....	66	trusses.....	59
Trestle number.....	37	27. Weight and cost draw-	
Truck wheel pits.....	114	bridges.....	60
Truss bridges.....	54	28. Quantities in abutments,	
Tunnels.....	84	deck bridges.....	62
Turnouts.....	17	29. Quantities in abutments,	
Turntables.....	172	half deck bridges.....	62
Table No. —		30. Quantities in abutments,	
1. Quantity and cost of rails		through bridges.....	62
per mile.....	4	31. Quantities in piers.....	63
2. Quantity and cost of		32. Quantities in piers.....	64
joints per mile.....	6	33. Quantities and cost pile	
3. Quantity and cost of bolts		trestle.....	68
per mile.....	7	34. Quantities and cost pile	
4. Quantity and cost of spikes		trestle.....	68
per mile.....	9	35. Quantities and cost frame	
5. Quantity and cost of ties		trestle.....	69
per mile.....	10	36. Quantities and cost Howe	
6. Quantity and cost of bal-		trusses.....	71
lasting, etc.....	11	37. Quantities in retaining	
7. Quantity and cost of track		walls.....	77
above subgrade.....	13	38. Cost of tunneling.....	86
8. Average cost of turnouts..	21	39. Cost of pumps and boil-	
9. Detail cost of turnouts		ers.....	178
	21, 22, 23	40. Cost of gasoline pumps..	179
10. Detail cost of crossovers..	23	41. Cost of cast iron pipes...	184
10a. Switch ties.....	24		

	PAGE		PAGE
Table No. — <i>continued</i>		Watchman's shelter.....	91
42. Cost of wrought iron pipes.....	185	Water —	
43. Capacity of pumps.....	186	information.....	194
44. Feet head pressure.....	189	service.....	183
45. Friction in pipes.....	190	stations.....	174
45a. Friction in elbows.....	191	Weight —	
46. Theoretical horsepower..	192	deck plate bridges.....	56
47. Steam pressure.....	193	deck trusses.....	58
48. Water by weight and measure.....	194	drawbridges.....	60
48a. Gallons per foot of pipe.	195	half deck plate bridges.....	57
49. Cost of water tanks.....	199	through trusses.....	59
50. Cost of shops.....	208	Weights of material.....	249
51. Power house equipment.	209	Wheel foundry.....	217
52. Electric traveling cranes	209	Whistle post.....	36
53. Steam cranes.....	209	Wing post sign.....	35
54. Timber unit stresses....	257	Wire fence.....	26
55. Timber unit stresses....	258	Wood —	
56. Section modulus wood beams.....	259	cattle guards.....	41
		gates.....	33
		snow fence.....	28
		Wooden beams.....	259
		Y	
W		Yard lift steam cranes.....	209
Walls, retaining.....	78	Yard limit post.....	86
Warning, bridge.....	38	Yards, stock.....	167



SHORT-TITLE CATALOGUE

OF THE
PUBLICATIONS

OF
JOHN WILEY & SONS,

NEW YORK.

LONDON: CHAPMAN & HALL, LIMITED.

ARRANGED UNDER SUBJECTS.

Descriptive circulars sent on application. Books marked with an asterisk (*) are sold at *net* prices only. All books are bound in cloth unless otherwise stated.

AGRICULTURE—HORTICULTURE—FORESTRY.

Armsby's Manual of Cattle-feeding.	12mo,	\$1 75
Principles of Animal Nutrition.	8vo,	4 00
Budd and Hansen's American Horticultural Manual:		
Part I. Propagation, Culture, and Improvement.	12mo,	1 50
Part II. Systematic Pomology.	12mo,	1 50
Elliott's Engineering for Land Drainage.	12mo,	1 50
Practical Farm Drainage.	12mo,	1 00
Graves's Forest Mensuration.	8vo,	4 00
Green's Principles of American Forestry.	12mo,	1 50
Grotenfelt's Principles of Modern Dairy Practice. (Woll.).	12mo,	2 00
*Herrick's Denatured or Industrial Alcohol.	8vo,	4 00
Kemp and Waugh's Landscape Gardening. (New Edition, Rewritten. In Preparation).		
* McKay and Larsen's Principles and Practice of Butter-making	8vo,	1 50
Maynard's Landscape Gardening as Applied to Home Decoration.	12mo,	1 50
Quaintance and Scott's Insects and Diseases of Fruits. (In Preparation).		
Sanderson's Insects Injurious to Staple Crops.	12mo,	1 50
*Schwarz's Longleaf Pine in Virgin Forests.	12mo,	1 25
Stockbridge's Rocks and Soils.	8vo,	2 50
Winton's Microscopy of Vegetable Foods.	8vo,	7 50
Woll's Handbook for Farmers and Dairymen.	16mo,	1 50

ARCHITECTURE.

Baldwin's Steam Heating for Buildings.	12mo,	2 50
Berg's Buildings and Structures of American Railroads.	4to,	5 00
Birkmire's Architectural Iron and Steel.	8vo,	3 50
Compound Riveted Girders as Applied in Buildings.	8vo,	2 00
Planning and Construction of American Theatres.	8vo,	3 00
Planning and Construction of High Office Buildings.	8vo,	3 50
Skeleton Construction in Buildings.	8vo,	3 00
Briggs's Modern American School Buildings.	8vo,	4 00
Byrne's Inspection of Material and Workmanship Employed in Construction.		
	16mo,	3 00
Carpenter's Heating and Ventilating of Buildings.	8vo,	4 00

* Corthell's Allowable Pressure on Deep Foundations.....	12mo,	1 25
Freitag's Architectural Engineering.....	8vo	3 50
Fireproofing of Steel Buildings.....	8vo,	2 50
French and Ives's Stereotomy.....	8vo,	2 50
Gerhard's Guide to Sanitary House-Inspection.....	16mo,	1 00
* Modern Baths and Bath Houses.....	8vo,	3 00
Sanitation of Public Buildings.....	12mo,	1 50
Theatre Fires and Panics.....	12mo,	1 50
Holley and Ladd's Analysis of Mixed Paints, Color Pigments, and Varnishes		
	Large 12mo,	2 50
Johnson's Statics by Algebraic and Graphic Methods.....	8vo,	2 00
Kellaway's How to Lay Out Suburban Home Grounds.....	8vo,	2 00
Kidder's Architects' and Builders' Pocket-book.....	16mo, mor.,	5 00
Maire's Modern Pigments and their Vehicles.....	12mo,	2 00
Merrill's Non-metallic Minerals: Their Occurrence and Uses.....	8vo,	4 00
Stones for Building and Decoration.....	8vo,	5 00
Monckton's Stair-building.....	4to,	4 00
Patton's Practical Treatise on Foundations.....	8vo,	5 00
Peabody's Naval Architecture.....	8vo,	7 50
Rice's Concrete-block Manufacture.....	8vo,	2 00
Richey's Handbook for Superintendents of Construction.....	16mo, mor.,	4 00
* Building Mechanics' Ready Reference Book:		
* Building Foreman's Pocket Book and Ready Reference. (In		
Preparation).		
* Carpenters' and Woodworkers' Edition.....	16mo, mor.	1 50
* Cement Workers and Plasterer's Edition.....	16mo, mor.	1 50
* Plumbers', Steam-Filters', and Tinnern's Edition.....	16mo, mor.	1 50
* Stone- and Brick-masons' Edition.....	16mo, mor.	1 50
Sabin's Industrial and Artistic Technology of Paints and Varnish.....	8vo,	3 00
Siebert and Biggin's Modern Stone-cutting and Masonry.....	8vo,	1 50
Snow's Principal Species of Wood.....	8vo,	3 50
Towne's Locks and Builders' Hardware.....	18mo, mor.	3 00
Wait's Engineering and Architectural Jurisprudence.....	8vo,	6 00
	Sheep,	6 50
Law of Contracts.....	8vo,	3 00
Law of Operations Preliminary to Construction in Engineering and Archi-		
tecture.....	8vo,	5 00
	Sheep,	5 50
Wilson's Air Conditioning.....	12mo,	1 50
Worcester and Atkinson's Small Hospitals, Establishment and Maintenance,		
Suggestions for Hospital Architecture, with Plans for a Small Hospital.		
	12mo,	1 25

ARMY AND NAVY.

Bernadou's Smokeless Powder, Nitro-cellulose, and the Theory of the Cellulose		
Molecule.....	12mo,	2 50
Chase's Art of Pattern Making.....	12mo,	2 50
Screw Propellers and Marine Propulsion.....	8vo,	3 00
Cloke's Gunner's Examiner.....	8vo,	1 50
Craig's Azimuth.....	4to,	3 50
Crehore and Squier's Polarizing Photo-chronograph.....	8vo,	3 00
* Davis's Elements of Law.....	8vo,	2 50
* Treatise on the Military Law of United States.....	8vo,	7 00
	Sheep,	7 50
De Brack's Cavalry Outpost Duties. (Carr.).....	24mo, mor.	2 00
* Dudley's Military Law and the Procedure of Courts-martial..	Large 12mo,	2 50
Durand's Resistance and Propulsion of Ships.....	8vo,	5 00

* Dyer's Handbook of Light Artillery.	12mo,	3 00
Eissler's Modern High Explosives.	8vo,	4 00
* Fieberger's Text-book on Field Fortification.	Large 12mo,	2 00
Hamilton and Bond's The Gunner's Catechism	18mo,	1 00
* Hoff's Elementary Naval Tactics.	8vo,	1 50
Ingalls's Handbook of Problems in Direct Fire.	8vo,	4 00
* Lissak's Ordnance and Gunnery.	8vo,	6 00
* Ludlow's Logarithmic and Trigonometric Tables	8vo,	1 00
* Lyons's Treatise on Electromagnetic Phenomena. Vols. I. and II. 8vo, each,	8vo,	6 00
* Mahan's Permanent Fortifications. (Mercur.)	8vo, half mor.	7 50
Manual for Courts-martial.	16mo, mor.	1 50
* Mercur's Attack of Fortified Places.	12mo,	2 00
* Elements of the Art of War.	8vo,	4 00
Metcalf's Cost of Manufactures—And the Administration of Workshops.	8vo,	5 00
* Ordnance and Gunnery. 2 vols.	Text 12mo, Plates atlas form	5 00
Nixon's Adjutants' Manual.	24mo,	1 00
Peabody's Naval Architecture.	8vo,	7 50
* Phelps's Practical Marine Surveying.	8vo,	2 50
Powell's Army Officer's Examiner.	12mo,	4 00
Sharpe's Art of Subsisting Armies in War.	18mo, mor.	1 50
* Tupes and Poole's Manual of Bayonet Exercises and Musketry Fencing.	24mo, leather,	50
* Weaver's Military Explosives.	8vo,	3 00
Woodhull's Notes on Military Hygiene.	16mo,	1 50

ASSAYING.

Betts's Lead Refining by Electrolysis.	8vo,	4 00
Fletcher's Practical Instructions in Quantitative Assaying with the Blowpipe.	16mo, mor.	1 50
Furman's Manual of Practical Assaying.	8vo,	3 00
Lodge's Notes on Assaying and Metallurgical Laboratory Experiments.	8vo,	3 00
Low's Technical Methods of Ore Analysis.	8vo,	3 00
Miller's Cyanide Process.	12mo,	1 00
Manual of Assaying.	12mo,	1 00
Minet's Production of Aluminum and its Industrial Use. (Waldo.)	12mo,	2 50
O'Driscoll's Notes on the Treatment of Gold Ores.	8vo,	2 00
Ricketts and Miller's Notes on Assaying.	8vo,	3 00
Robine and Lenglen's Cyanide Industry. (Le Clerc.)	8vo,	4 00
Ulke's Modern Electrolytic Copper Refining.	8vo,	3 00
Wilson's Chlorination Process.	12mo,	1 50
Cyanide Processes,	12mo,	1 50

ASTRONOMY.

Comstock's Field Astronomy for Engineers.	8vo,	2 50
Craig's Azimuth.	4to,	3 50
Crandall's Text-book on Geodesy and Least Squares.	8vo,	3 00
Doolittle's Treatise on Practical Astronomy.	8vo,	4 00
Gore's Elements of Geodesy.	8vo,	2 50
Hayford's Text-book of Geodetic Astronomy.	8vo,	3 00
Merriman's Elements of Precise Surveying and Geodesy.	8vo,	2 50
* Michie and Harlow's Practical Astronomy.	8vo,	3 00
Rust's Ex-meridian Altitude, Azimuth and Star-Finding Tables. (In Press.)		
* White's Elements of Theoretical and Descriptive Astronomy	12mo,	2 00

CHEMISTRY.

Abderhalden's Physiological Chemistry in Thirty Lectures. (Hall and Defren). (In Press.)		
* Abegg's Theory of Electrolytic Dissociation. (von Ende.)	12mo,	1 25
Adriance's Laboratory Calculations and Specific Gravity Tables.	12mo,	1 25
Alexeyeff's General Principles of Organic Syntheses. (Matthews.)	8vo,	3 00
Allen's Tables for Iron Analysis.	8vo,	3 00
Arnold's Compendium of Chemistry. (Mandel.)	Large 12mo,	3 50
Association of State and National Food and Dairy Departments, Hartford Meeting, 1906.	8vo,	3 00
Jamestown Meeting, 1907.	8vo,	3 00
Austen's Notes for Chemical Students	12mo,	1 50
Baskerville's Chemical Elements. (In Preparation).		
Bernadou's Smokeless Powder.—Nitro-cellulose, and Theory of the Cellulose Molecule	12mo,	2 50
* Blanchard's Synthetic Inorganic Chemistry.	12mo,	1 00
* Browning's Introduction to the Rarer Elements.	8vo,	1 50
Brush and Penfield's Manual of Determinative Mineralogy.	8vo,	4 00
* Claassen's Beet-sugar Manufacture. (Hall and Rolfe.)	8vo,	3 00
Classen's Quantitative Chemical Analysis by Electrolysis. (Boltwood.)	8vo,	3 00
Cohn's Indicators and Test-papers.	12mo,	2 00
Tests and Reagents.	8vo,	3 00
* Danneel's Electrochemistry. (Merriam.)	12mo,	1 25
Duhem's Thermodynamics and Chemistry. (Burgess.)	8vo,	4 00
Eakle's Mineral Tables for the Determination of Minerals by their Physical Properties	8vo,	1 25
Eissler's Modern High Explosives.	8vo,	4 00
Effront's Enzymes and their Applications. (Prescott.)	8vo,	3 00
Erdmann's Introduction to Chemical Preparations. (Dunlap.)	12mo,	1 25
* Fischer's Physiology of Alimentation	Large 12mo,	2 00
Fletcher's Practical Instructions in Quantitative Assaying with the Blowpipe.	12mo, mor.	1 50
Fowler's Sewage Works Analyses.	12mo,	2 00
Fresenius's Manual of Qualitative Chemical Analysis. (Wells.)	8vo,	5 00
Manual of Qualitative Chemical Analysis, Part I. Descriptive. (Wells.)	8vo,	3 00
Quantitative Chemical Analysis. (Cohn.) 2 vols.	8vo,	12 50
When Sold Separately, Vol. I, \$6. Vol. II, \$8.		
Fuertes's Water and Public Health.	12mo,	1 50
Furman's Manual of Practical Assaying.	8vo,	3 00
* Getman's Exercises in Physical Chemistry.	12mo,	2 00
Gill's Gas and Fuel Analysis for Engineers.	12mo,	1 25
* Gooch and Browning's Outlines of Qualitative Chemical Analysis.	Large 12mo,	1 25
Grotenfelt's Principles of Modern Dairy Practice. (Woll.)	12mo,	2 00
Groth's Introduction to Chemical Crystallography (Marshall)	12mo,	1 25
Hammarsten's Text-book of Physiological Chemistry. (Mandel.)	8vo,	4 00
Hanausek's Microscopy of Technical Products. (Winton.)	8vo,	5 00
* Haskins and Macleod's Organic Chemistry	12mo,	2 00
Helm's Principles of Mathematical Chemistry. (Morgan.)	12mo,	1 50
Hering's Ready Reference Tables (Conversion Factors).	16mo, mor.	2 50
* Herrick's Denatured or Industrial Alcohol.	8vo,	4 00
Hinds's Inorganic Chemistry.	8vo,	3 00
* Laboratory Manual for Students	12mo,	1 00
* Holleman's Laboratory Manual of Organic Chemistry for Beginners.		
(Walker.)	12mo,	1 00
Text-book of Inorganic Chemistry. (Cooper.)	8vo,	2 50
Text-book of Organic Chemistry. (Walker and Mott.)	8vo,	2 50
Holley and Ladd's Analysis of Mixed Paints, Color Pigments, and Varnishes.	Large 12mo	2 50

Hopkins's Oil-chemists' Handbook.....	8vo,	3 00
Iddings's Rock Minerals.....	8vo,	5 00
Jackson's Directions for Laboratory Work in Physiological Chemistry..	8vo,	1 25
Johannsen's Determination of Rock-forming Minerals in Thin Sections..	8vo,	4 00
Keep's Cast Iron.....	8vo,	2 50
Ladd's Manual of Quantitative Chemical Analysis.....	12mo,	1 00
Landauer's Spectrum Analysis. (Tingle.).....	8vo,	3 00
* Langworthy and Austen's Occurrence of Aluminium in Vegetable Products, Animal Products, and Natural Waters.....	8vo,	2 00
Lassar-Cohn's Application of Some General Reactions to Investigations in Organic Chemistry. (Tingle.).....	12mo,	1 00
Leach's Inspection and Analysis of Food with Special Reference to State Control.....	8vo,	7 50
Löb's Electrochemistry of Organic Compounds. (Lorenz.).....	8vo,	3 00
Lodge's Notes on Assaying and Metallurgical Laboratory Experiments...	8vo,	3 00
Low's Technical Method of Ore Analysis.....	8vo,	3 00
Lunge's Techno-chemical Analysis. (Cohn.).....	12mo	1 00
* McKay and Larsen's Principles and Practice of Butter-making.....	8vo,	1 50
Maire's Modern Pigments and their Vehicles.....	12mo,	2 00
Mandel's Handbook for Bio-chemical Laboratory.....	12mo,	1 50
* Martin's Laboratory Guide to Qualitative Analysis with the Blowpipe..	12mo,	60
Mason's Examination of Water. (Chemical and Bacteriological.).....	12mo,	1 25
Water-supply. (Considered Principally from a Sanitary Standpoint.)	8vo,	4 00
Matthews's The Textile Fibres. 2d Edition, Rewritten.....	8vo,	4 00
Meyer's Determination of Radicles in Carbon Compounds. (Tingle.)..	12mo,	1 00
Miller's Cyanide Process.....	12mo,	1 00
Manual of Assaying.....	12mo,	1 00
Minet's Production of Aluminum and its Industrial Use. (Waldo.)....	12mo,	2 50
Mixer's Elementary Text-book of Chemistry.....	12mo,	1 50
Morgan's Elements of Physical Chemistry.....	12mo,	3 00
Outline of the Theory of Solutions and its Results.....	12mo,	1 00
* Physical Chemistry for Electrical Engineers.....	12mo,	1 50
Morse's Calculations used in Cane-sugar Factories.....	16mo, mor.	1 50
* Muir's History of Chemical Theories and Laws.....	8vo,	4 00
Mulliken's General Method for the Identification of Pure Organic Compounds.		
Vol. I.....	Large 8vo,	5 00
O'Driscoll's Notes on the Treatment of Gold Ores.....	8vo,	2 00
Ostwald's Conversations on Chemistry. Part One. (Ramsey.).....	12mo,	1 50
" " " " Part Two. (Turnbull.)....	12mo,	2 00
* Palmer's Practical Test Book of Chemistry.....	12mo,	1 00
* Pauli's Physical Chemistry in the Service of Medicine. (Fischer.)....	12mo,	1 25
* Penfield's Notes on Determinative Mineralogy and Record of Mineral Tests.	8vo, paper,	50
Tables of Minerals, Including the Use of Minerals and Statistics of Domestic Production.....	8vo,	1 00
Pictet's Alkaloids and their Chemical Constitution. (Biddle.).....	8vo,	5 00
Poole's Calorific Power of Fuels.....	8vo,	3 00
Prescott and Winslow's Elements of Water Bacteriology, with Special Reference to Sanitary Water Analysis.....	12mo,	1 50
* Reisig's Guide to Piece-dyeing.....	8vo,	25 00
Richards and Woodman's Air, Water, and Food from a Sanitary Standpoint..	8vo,	2 00
Ricketts and Miller's Notes on Assaying.....	8vo,	3 00
Rideal's Disinfection and the Preservation of Food.....	8vo,	4 00
Sewage and the Bacterial Purification of Sewage.....	8vo,	4 00
Riggs's Elementary Manual for the Chemical Laboratory.....	8vo,	1 25
Robine and Lenglen's Cyanide Industry. (Le Clerc.).....	8vo,	4 00
Ruddiman's Incompatibilities in Prescriptions.....	8vo,	2 00
Whys in Pharmacy.....	12mo,	1 00

* Ives's Adjustments of the Engineer's Transit and Level.	16mo, Bds.	25
Ives and Hilts's Problems in Surveying	16mo, mor.	1 50
Johnson's (J. B.) Theory and Practice of Surveying.	Small 8vo,	4 00
Johnson's (L. J.) Statics by Algebraic and Graphic Methods.	8vo,	2 00
Kinnicutt, Winslow and Pratt's Purification of Sewage. (In Preparation).		
Laplace's Philosophical Essay on Probabilities. (Truscott and Emory.)	12mo,	2 00
Mahan's Descriptive Geometry.	8vo,	1 50
Treatise on Civil Engineering. (1873.) (Wood.)	8vo,	5 00
Merriman's Elements of Precise Surveying and Geodesy.	8vo,	2 50
Merriman and Brooks's Handbook for Surveyors.	16mo, mor.	2 00
Morrison's Elements of Highway Engineering. (In Press.)		
Nugent's Plane Surveying.	8vo,	3 50
Ogden's Sewer Design.	12mo,	2 00
Parsons's Disposal of Municipal Refuse.	8vo,	2 00
Patton's Treatise on Civil Engineering.	8vo, half leather,	7 50
Reed's Topographical Drawing and Sketching	4to,	5 00
Rideal's Sewage and the Bacterial Purification of Sewage.	8vo,	4 00
Riemer's Shaft-sinking under Difficult Conditions. (Corning and Peele.)	8vo,	3 00
Siebert and Biggin's Modern Stone-cutting and Masonry.	8vo,	1 50
Smith's Manual of Topographical Drawing. (McMillan.)	8vo,	2 50
Soper's Air and Ventilation of Subways. (In Press.)		
Tracy's Plane Surveying.	16mo, mor.	3 00
* Trautwine's Civil Engineer's Pocket-book.	16mo, mor.	5 00
Venable's Garbage Crematories in America.	8vo,	2 00
Methods and Devices for Bacterial Treatment of Sewage.	8vo,	3 00
Wait's Engineering and Architectural Jurisprudence.	8vo,	6 00
	Sheep,	6 50
Law of Contracts.	8vo,	3 00
Law of Operations Preliminary to Construction in Engineering and Architecture.	8vo,	5 00
	Sheep,	5 50
Warren's Stereotomy—Problems in Stone-cutting.	8vo,	2 50
* Waterbury's Vest-Pocket Hand-book of Mathematics for Engineers.		
	2 $\frac{1}{4}$ × 5 $\frac{3}{8}$ inches, mor.	1 00
Webb's Problems in the Use and Adjustment of Engineering Instruments.		
	16mo, mor.	1 25
Wilson's Topographic Surveying.	8vo,	3 50

BRIDGES AND ROOFS.

Boller's Practical Treatise on the Construction of Iron Highway Bridges.	8vo,	2 00
Burr and Falk's Design and Construction of Metallic Bridges	8vo,	5 00
Influence Lines for Bridge and Roof Computations.	8vo,	3 00
Du Bois's Mechanics of Engineering. Vol. II.	Small 4to,	10 00
Foster's Treatise on Wooden Trestle Bridges.	4to,	5 00
Fowler's Ordinary Foundations.	8vo,	3 50
French and Ives's Stereotomy.	8vo,	2 50
Greene's Arches in Wood, Iron, and Stone.	8vo,	2 50
Bridge Trusses.	8vo,	2 50
Roof Trusses.	8vo,	1 25
Grimm's Secondary Stresses in Bridge Trusses.	8vo,	2 50
Heller's Stresses in Structures and the Accompanyin Deformations.	8vo,	
Howe's Design of Simple Roof-trusses in Wood and Steel.	8vo,	2 00
Symmetrical Masonry Arches.	8vo,	2 50
Treatise on Arches.	8vo,	4 00
Johnson, Bryan, and Turneure's Theory and Practice in the Designing of Modern Framed Structures.	Small 4to,	10 00

Merriman and Jacoby's Text-book on Roofs and Bridges:

Part I. Stresses in Simple Trusses.....	8vo,	2 50
Part II. Graphic Statics.....	8vo,	2 50
Part III. Bridge Design.....	8vo,	2 50
Part IV. Higher Structures.....	8vo,	2 50
Morison's Memphis Bridge.....	Oblong 4to,	10 00
Sondericker's Graphic Statics, with Applications to Trusses, Beams, and Arches.....	8vo,	2 00
Waddell's De Pontibus, Pocket-book for Bridge Engineers.....	16mo, mor,	2 00
* Specifications for Steel Bridges.....	12mo,	50
Waddell and Harrington's Bridge Engineering. (In Preparation.)		
Wright's Designing of Draw-spans. Two parts in one volume.....	8vo,	3 50

HYDRAULICS.

Barnes's Ice Formation.....	8vo,	3 00
Bazin's Experiments upon the Contraction of the Liquid Vein Issuing from an Orifice. (Trautwine.).....	8vo,	2 00
Bovey's Treatise on Hydraulics.....	8vo,	5 00
Church's Diagrams of Mean Velocity of Water in Open Channels.....	Oblong 4to, paper,	1 50
Hydraulic Motors.....	8vo,	2 00
Mechanics of Engineering.....	8vo,	6 00
Coffin's Graphical Solution of Hydraulic Problems.....	16mo, morocco,	2 50
Fletcher's Dynamometers, and the Measurement of Power.....	12mo,	3 00
Folwell's Water-supply Engineering.....	8vo,	4 00
Frizzell's Water-power.....	8vo,	5 00
Fuertes's Water and Public Health.....	12mo,	1 50
Water-filtration Works.....	12mo,	2 50
Ganguillet and Kutter's General Formula for the Uniform Flow of Water in Rivers and Other Channels. (Hering and Trautwine.).....	8vo,	4 00
Hazen's Clean Water and How to Get It.....	Large 12mo,	1 50
Filtration of Public Water-supplies.....	8vo,	3 00
Hazlehurst's Towers and Tanks for Water-works.....	8vo,	2 50
Herschel's 115 Experiments on the Carrying Capacity of Large, Riveted, Metal Conduits.....	8vo,	2 00
Hoyt and Grover's River Discharge.....	8vo,	2 00
Hubbard and Kiersted's Water-works Management and Maintenance.....	8vo,	4 00
* Lyndon's Development and Electrical Distribution of Water Power.....	8vo,	3 00
Mason's Water-supply. (Considered Principally from a Sanitary Standpoint.).....	8vo,	4 00
Merriman's Treatise on Hydraulics.....	8vo,	5 00
* Michie's Elements of Analytical Mechanics.....	8vo,	4 00
Molitor's Hydraulics of Rivers, Weirs and Sluices. (In Press.)		
Schuyler's Reservoirs for Irrigation, Water-power, and Domestic Water-supply.....	Large 8vo,	5 00
* Thomas and Watt's Improvement of Rivers.....	4to,	6 00
Turneure and Russell's Public Water-supplies.....	8vo,	5 00
Wegmann's Design and Construction of Dams. 5th Ed., enlarged.....	4to,	6 00
Water-supply of the City of New York from 1658 to 1895.....	4to,	10 00
Whipple's Value of Pure Water.....	Large 12mo,	1 00
Williams and Hazen's Hydraulic Tables.....	8vo,	1 50
Wilson's Irrigation Engineering.....	Small 8vo,	4 00
Wolff's Windmill as a Prime Mover.....	8vo,	3 00
Wood's Elements of Analytical Mechanics.....	8vo,	3 00
Turbines.....	8vo,	2 50

MATERIALS OF ENGINEERING.

Baker's Roads and Pavements.	8vo,	5 00
Treatise on Masonry Construction.	8vo,	5 00
Birkmire's Architectural Iron and Steel.	8vo,	3 50
Compound Riveted Girders as Applied in Buildings.	8vo,	2 00
Black's United States Public Works	Oblong 4to,	5 00
Bleining's Manufacture of Hydraulic Cement. (In Preparation.)		
* Bovey's Strength of Materials and Theory of Structures.	8vo,	7 50
Burr's Elasticity and Resistance of the Materials of Engineering.	8vo,	7 50
Byrne's Highway Construction.	8vo,	5 00
Inspection of the Materials and Workmanship Employed in Construction.		
	16mo,	3 00
Church's Mechanics of Engineering.	8vo,	6 00
Du Bois's Mechanics of Engineering.		
Vol. I. Kinematics, Statics, Kinetics.	Small 4to,	7 50
Vol. II. The Stresses in Framed Structures, Strength of Materials and Theory of Flexures.	Small 4to,	10 00
*Eckel's Cements, Limes, and Plasters.	8vo,	6 00
Stone and Clay Products used in Engineering. (In Preparation.)		
Fowler's Ordinary Foundations.	8vo,	3 50
Graves's Forest Mensuration.	8vo,	4 00
Green's Principles of American Forestry.	12mo,	1 50
* Greene's Structural Mechanics.	8vo,	2 50
Holly and Ladd's Analysis of Mixed Paints, Color Pigments and Varnishes		
	Large 12mo,	2 50
Johnson's Materials of Construction.	Large 8vo,	6 00
Keep's Cast Iron.	8vo,	2 50
Kidder's Architects and Builders' Pocket-book.	16mo,	5 00
Lanza's Applied Mechanics.	8vo,	7 50
Maire's Modern Pigments and their Vehicles	12mo,	2 00
Martens's Handbook on Testing Materials. (Henning.) 2 vols.	8vo,	7 50
Maurer's Technical Mechanics.	8vo,	4 00
Merrill's Stones for Building and Decoration.	8vo,	5 00
Merriman's Mechanics of Materials.	8vo,	5 00
* Strength of Materials	12mo,	1 00
Metcalfe's Steel. A Manual for Steel-users.	12mo,	2 00
Patton's Practical Treatise on Foundations.	8vo,	5 00
Rice's Concrete Block Manufacture	8vo,	2 00
Richardson's Modern Asphalt Pavements.	8vo,	3 00
Richey's Handbook for Superintendents of Construction.	16mo, mor.,	4 00
* Ries's Clays: Their Occurrence, Properties, and Uses.	8vo,	5 00
Sabin's Industrial and Artistic Technology of Paints and Varnish.	8vo,	3 00
* Schwarz's Longleaf Pine in Virgin Forest	12mo,	1 25
Snow's Principal Species of Wood.	8vo,	3 50
Spalding's Hydraulic Cement.	12mo,	2 00
Text-book on Roads and Pavements.	12mo,	2 00
Taylor and Thompson's Treatise on Concrete, Plain and Reinforced.	8vo,	5 00
Thurston's Materials of Engineering. In Three Parts.	8vo,	8 00
Part I. Non-metallic Materials of Engineering and Metallurgy.	8vo,	2 00
Part II. Iron and Steel.	8vo,	3 50
Part III. A Treatise on Brasses, Bronzes, and Other Alloys and their Constituents.	8vo,	2 50
Tillson's Street Pavements and Paving Materials.	8vo,	4 00
Turneure and Maurer's Principles of Reinforced Concrete Construction.	8vo,	3 00
Wood's (De V.) Treatise on the Resistance of Materials, and an Appendix on the Preservation of Timber.	8vo,	2 00
Wood's (M. P.) Rustless Coatings: Corrosion and Electrolysis of Iron and Steel.	8vo,	4 00

RAILWAY ENGINEERING.

Andrews's Handbook for Street Railway Engineers.....	3x5 inches, mor.	1 25
Berg's Buildings and Structures of American Railroads4to,	5 00
Brooks's Handbook of Street Railroad Location.....	16mo, mor.	1 50
Butt's Civil Engineer's Field-book.....	16mo, mor.	2 50
Crandall's Railway and Other Earthwork Tables.....	8vo,	1 50
Transition Curve.....	16mo, mor.	1 50
* Crockett's Methods for Earthwork Computations.....	8vo,	1 50
Dawson's "Engineering" and Electric Traction Pocket-book.....	16mo, mor.	5 00
Dredge's History of the Pennsylvania Railroad: (1879).....	Paper,	5 00
Fisher's Table of Cubic Yards.....	Cardboard,	25
Godwin's Railroad Engineers' Field-book and Explorers' Guide...	16mo, mor.	2 50
Hudson's Tables for Calculating the Cubic Contents of Excavations and Embankments.....	8vo,	1 00
Ives and Hilts's Problems in Surveying, Railroad Surveying and Geodesy.....	16mo, mor.	1 50
Molitor and Beard's Manual for Resident Engineers.....	16mo,	1 00
Nagle's Field Manual for Railroad Engineers.....	16mo, mor.	3 00
Philbrick's Field Manual for Engineers.....	16mo, mor.	3 00
Raymond's Railroad Engineering. 3 volumes.		
Vol. I. Railroad Field Geometry. (In Preparation.)		
Vol. II. Elements of Railroad Engineering.....	8vo,	3 50
Vol. III. Railroad Engineer's Field Book. (In Preparation.)		
Searles's Field Engineering.....	16mo, mor.	3 00
Railroad Spiral.....	16mo, mor.	1 50
Taylor's Prismoïdal Formulæ and Earthwork.....	8vo,	1 50
* Trautwine's Field Practice of Laying Out Circular Curves for Railroads.....	12mo, mor.	2 50
* Method of Calculating the Cubic Contents of Excavations and Embankments by the Aid of Diagrams.....	8vo,	2 00
Webb's Economics of Railroad Construction.....	Large 12mo,	2 50
Railroad Construction.....	16mo, mor.	5 00
Wellington's Economic Theory of the Location of Railways.....	Small 8vo,	5 00

DRAWING.

Barr's Kinematics of Machinery.....	8vo,	2 50
* Bartlett's Mechanical Drawing.....	8vo,	3 00
* " " " " Abridged Ed.....	8vo,	1 50
Coolidge's Manual of Drawing.....	8vo, paper,	1 00
Coolidge and Freeman's Elements of General Drafting for Mechanical Engineers.....	Oblong 4to,	2 50
Durley's Kinematics of Machines.....	8vo,	4 00
Emch's Introduction to Projective Geometry and its Applications.....	8vo,	2 50
Hill's Text-book on Shades and Shadows, and Perspective.....	8vo,	2 00
Jamison's Advanced Mechanical Drawing.....	8vo,	2 00
Elements of Mechanical Drawing.....	8vo,	2 50
Jones's Machine Design:		
Part I. Kinematics of Machinery.....	8vo,	1 50
Part II. Form, Strength, and Proportions of Parts.....	8vo,	3 00
MacCord's Elements of Descriptive Geometry.....	8vo,	3 00
Kinematics; or, Practical Mechanism.....	8vo,	5 00
Mechanical Drawing.....	.4to,	4 00
Velocity Diagrams.....	8vo,	1 50
McLeod's Descriptive Geometry.....	Large 12mo,	1 50
* Mahan's Descriptive Geometry and Stone-cutting.....	8vo,	1 50
Industrial Drawing. (Thompson.).....	8vo,	3 50

Moyer's Descriptive Geometry.....	8vo,	2 00
Reed's Topographical Drawing and Sketching.....	4to,	5 00
Reid's Course in Mechanical Drawing.....	8vo,	2 00
Text-book of Mechanical Drawing and Elementary Machine Design.....	8vo,	3 00
Robinson's Principles of Mechanism.....	8vo,	3 00
Schwamb and Merrill's Elements of Mechanism.....	8vo,	3 00
Smith's (R. S.) Manual of Topographical Drawing. (McMillan.).....	8vo,	2 50
Smith (A. W.) and Marx's Machine Design.....	8vo,	3 00
* Titsworth's Elements of Mechanical Drawing.....	Oblong 8vo,	1 25
Warren's Drafting Instruments and Operations.....	12mo,	1 25
Elements of Descriptive Geometry, Shadows, and Perspective.....	8vo,	3 50
Elements of Machine Construction and Drawing.....	8vo,	7 50
Elements of Plane and Solid Free-hand Geometrical Drawing.....	1. 2mo,	1 00
General Problems of Shades and Shadows.....	8vo,	3 00
Manual of Elementary Problems in the Linear Perspective of Form and Shadow.....	12mo,	1 00
Manual of Elementary Projection Drawing.....	12mo,	1 50
Plane Problems in Elementary Geometry.....	12mo,	1 25
Problems, Theorems, and Examples in Descriptive Geometry.....	8vo,	2 50
Weisbach's Kinematics and Power of Transmission. (Hermann and Klein.).....	8vo,	5 00
Wilson's (H. M.) Topographic Surveying.....	8vo,	3 50
Wilson's (V. T.) Free-hand Lettering.....	8vo,	1 00
Free-hand Perspective.....	8vo,	2 50
Woolf's Elementary Course in Descriptive Geometry.....	Large 8vo,	3 00

ELECTRICITY AND PHYSICS.

* Abegg's Theory of Electrolytic Dissociation. (von Ende.).....	12mo,	1 25
Andrews's Hand-Book for Street Railway Engineering.....	3×5 inches, mor.,	1 25
Anthony and Brackett's Text-book of Physics. (Magie.).....	Large 12mo,	3 00
Anthony's Lecture-notes on the Theory of Electrical Measurements.....	12mo,	1 00
Benjamin's History of Electricity.....	8vo,	3 00
Voltaic Cell.....	8vo,	3 00
Betts's Lead Refining and Electrolysis.....	8vo,	4 00
Classen's Quantitative Chemical Analysis by Electrolysis. (Boltwood.).....	8vo,	3 00
* Collins's Manual of Wireless Telegraphy.....	12mo,	1 50
Mor.	2 00	
Crehore and Squier's Polarizing Photo-chronograph.....	8vo,	3 00
* Danneel's Electrochemistry. (Merriam.).....	12mo,	1 25
Dawson's "Engineering" and Electric Traction Pocket-book.....	16mo, mor	5 00
Dolezalek's Theory of the Lead Accumulator (Storage Battery). (von Ende.) 12mo,	2 50	
Duhem's Thermodynamics and Chemistry. (Burgess.).....	8vo,	4 00
Flather's Dynamometers, and the Measurement of Power.....	12mo,	3 00
Gilbert's De Magnete. (Mottelay.).....	8vo,	2 50
* Hanchett's Alternating Currents.....	12mo,	1 00
Hering's Ready Reference Tables (Conversion Factors).....	16mo, mor.	2 50
Hobart and Ellis's High-speed Dynamo Electric Machinery. (In Press.)		
Holman's Precision of Measurements.....	8vo,	2 00
Telescopic Mirror-scale Method, Adjustments, and Tests....	Large 8vo,	75
* Karapetoff's Experimental Electrical Engineering.....	8vo,	6 00
Kinzbrunner's Testing of Continuous-current Machines.....	8vo,	2 00
Landauer's Spectrum Analysis. (Tingle.).....	8vo,	3 00
Le Chatelier's High-temperature Measurements. (Boudouard—Burgess.)	12mo,	3 00
Löb's Electrochemistry of Organic Compounds. (Lorenz.).....	8vo,	3 00
* Lyndon's Development and Electrical Distribution of Water Power....	8vo,	3 00
* Lyons's Treatise on Electromagnetic Phenomena. Vols. I. and II. 8vo, each,		6 00
* Michie's Elements of Wave Motion Relating to Sound and Light.....	8vo,	4 00

Morgan's Outline of the Theory of Solution and its Results	12mo,	1 00
* Physical Chemistry for Electrical Engineers	12mo,	1 50
Niaudet's Elementary Treatise on Electric Batteries. (Fishback)	12mo,	2 50
* Norris's Introduction to the Study of Electrical Engineering	8vo,	2 50
* Parshall and Hobart's Electric Machine Design	4to, half morocco,	12 50
Reagan's Locomotives: Simple, Compound, and Electric. - New Edition.		
	Large 12mo,	3 50
* Rosenberg's Electrical Engineering. (Haldane Gee—Kinzbrunner.)	8vo,	2 00
Ryan, Norris, and Hoxie's Electrical Machinery. Vol. I.	8vo,	2 50
Schapper's Laboratory Guide for Students in Physical Chemistry	12mo,	1 00
Thurston's Stationary Steam-engines.	8vo,	2 50
* Tillman's Elementary Lessons in Heat.	8vo,	1 50
Tory and Pitcher's Manual of Laboratory Physics.	Large 12mo,	2 00
Ulke's Modern Electrolytic Copper Refining.	8vo,	3 00

LAW.

* Davis's Elements of Law.	8vo,	2 50
* Treatise on the Military Law of United States.	8vo,	7 00
*	Sheep,	7 50
* Dudley's Military Law and the Procedure of Courts-martial	Large 12mo,	2 50
Manual for Courts-martial.	16mo, mor.	1 50
Wait's Engineering and Architectural Jurisprudence.	8vo,	6 00
	Sheep,	6 50
Law of Contracts.	8vo,	3 00
Law of Operations Preliminary to Construction in Engineering and Architecture.	8vo	5 00
	Sheep,	5 50

MATHEMATICS.

Baker's Elliptic Functions	8vo,	1 50
Briggs's Elements of Plane Analytic Geometry. (Böcher)	12mo,	1 00
* Buchanan's Plane and Spherical Trigonometry	8vo,	1 00
Byerley's Harmonic Functions	8vo,	1 00
Chandler's Elements of the Infinitesimal Calculus	12mo,	2 00
Compton's Manual of Logarithmic Computations	12mo,	1 50
Davis's Introduction to the Logic of Algebra	8vo,	1 50
* Dickson's College Algebra	Large 12mo,	1 50
* Introduction to the Theory of Algebraic Equations	Large 12mo,	1 25
Emch's Introduction to Projective Geometry and its Applications	8vo,	2 50
Fiske's Functions of a Complex Variable	8vo,	1 00
Halsted's Elementary Synthetic Geometry	8vo,	1 50
Elements of Geometry	8vo,	1 75
* Rational Geometry	12mo,	1 50
Hyde's Grassmann's Space Analysis.	8vo,	1 00
* Jonnson's (J. B.) Three-place Logarithmic Tables: Vest-pocket size, paper,		15
	100 copies,	5 00
*	Mounted on heavy cardboard, 8×10 inches,	25
	10 copies,	2 00
Johnson's (W. W.) Abridged Editions of Differential and Integral Calculus		
	Large 12mo, 1 vol.	2 50
Curve Tracing in Cartesian Co-ordinates	12mo,	1 00
Differential Equations.	8vo,	1 00
Elementary Treatise on Differential Calculus. (In Press.)		
Elementary Treatise on the Integral Calculus	Large 12mo,	1 50
* Theoretical Mechanics.	12mo,	3 00
Theory of Errors and the Method of Least Squares.	12mo,	1 50
Treatise on Differential Calculus.	Large 12mo,	3 00
Treatise on the Integral Calculus.	Large 12mo,	3 00
Treatise on Ordinary and Partial Differential Equations. Large 12mo,		3 50

Laplace's Philosophical Essay on Probabilities. (Truscott and Emory).	12mo,	2 00
* Ludlow and Bass's Elements of Trigonometry and Logarithmic and Other Tables	8vo,	3 00
Trigonometry and Tables published separately	Each,	2 00
* Ludlow's Logarithmic and Trigonometric Tables	8vo,	1 00
Macfarlane's Vector Analysis and Quaternions	8vo,	1 00
McMahon's Hyperbolic Functions	8vo,	1 00
Manning's Irrational Numbers and their Representation by Sequences and Series	12mo,	1 25
Mathematical Monographs. Edited by Mansfield Merriman and Robert S. Woodward.	Octavo, each	1 00
No. 1. History of Modern Mathematics, by David Eugene Smith.		
No. 2. Synthetic Projective Geometry, by George Bruce Halsted.		
No. 3. Determinants, by Laenas Gifford Weld. No. 4. Hyperbolic Functions, by James McMahon. No. 5. Harmonic Functions, by William E. Byerly. No. 6. Grassmann's Space Analysis, by Edward W. Hyde. No. 7. Probability and Theory of Errors, by Robert S. Woodward. No. 8. Vector Analysis and Quaternions, by Alexander Macfarlane. No. 9. Differential Equations, by William Woolsey Johnson. No. 10. The Solution of Equations, by Mansfield Merriman. No. 11. Functions of a Complex Variable, by Thomas S. Fiske.		
Maurer's Technical Mechanics	8vo,	4 00
Merriman's Method of Least Squares	8vo,	2 00
Solution of Equations	8vo,	1 00
Rice and Johnson's Differential and Integral Calculus. 2 vols. in one.	Large 12mo,	1 50
Elementary Treatise on the Differential Calculus	Large 12mo,	3 00
Smith's History of Modern Mathematics	8vo,	1 00
* Veblen and Lennes's Introduction to the Real Infinitesimal Analysis of One Variable	8vo,	2 00
* Waterbury's Vest Pocket Hand-Book of Mathematics for Engineers.	2 $\frac{1}{8}$ × 5 $\frac{1}{8}$ inches, mor.,	1 00
Weld's Determinations	8vo,	1 00
Wood's Elements of Co-ordinate Geometry	8vo,	2 00
Woodward's Probability and Theory of Errors	8vo,	1 00

MECHANICAL ENGINEERING.

MATERIALS OF ENGINEERING, STEAM-ENGINES AND BOILERS.

Bacon's Forge Practice	12mo,	1 50
Baldwin's Steam Heating for Buildings	12mo,	2 50
Barr's Kinematics of Machinery	8vo,	2 50
* Bartlett's Mechanical Drawing	8vo,	3 00
* " " " " Abridged Ed.	8vo,	1 50
Benjamin's Wrinkles and Recipes	12mo,	2 00
* Burr's Ancient and Modern Engineering and the Isthmian Canal	8vo,	3 50
Carpenter's Experimental Engineering	8vo,	6 00
Heating and Ventilating Buildings	8vo,	4 00
Clerk's Gas and Oil Engine	Large 12mo,	4 00
Compton's First Lessons in Metal Working	12mo,	1 50
Compton and De Groot's Speed Lathe	12mo,	1 50
Coolidge's Manual of Drawing	8vo, paper,	1 00
Coolidge and Freeman's Elements of General Drafting for Mechanical Engineers	Oblong 4to,	2 50
Cromwell's Treatise on Belts and Pulleys	12mo,	1 50
Treatise on Toothed Gearing	12mo,	1 50
Durley's Kinematics of Machines	8vo,	4 00

Flather's Dynamometers and the Measurement of Power.....	12mo,	3 00
Rope Driving.....	12mo,	2 00
Gill's Gas and Fuel Analysis for Engineers.....	12mo,	1 25
Goss's Locomotive Sparks.....	8vo,	2 00
Hall's Car Lubrication.....	12mo,	1 00
Hering's Ready Reference Tables (Conversion Factors).....	16mo, mor.,	2 50
Hobart and Ellis's High Speed Dynamo Electric Machinery. (In Press.)		
Hutton's Gas Engine.....	8vo,	5 00
Jamison's Advanced Mechanical Drawing.....	8vo,	2 00
Elements of Mechanical Drawing.....	8vo,	2 50
Jones's Machine Design:		
Part I. Kinematics of Machinery.....	8vo,	1 50
Part II. Form, Strength, and Proportions of Parts.....	8vo,	3 00
Kent's Mechanical Engineers' Pocket-book.....	16mo, mor.,	5 00
Kerr's Power and Power Transmission.....	8vo,	2 00
Leonard's Machine Shop Tools and Methods.....	8vo,	4 00
* Lorenz's Modern Refrigerating Machinery. (Pope, Haven, and Dean.)	8vo,	4 00
MacCord's Kinematics; or, Practical Mechanism.....	8vo,	5 00
Mechanical Drawing.....	4to,	4 00
Velocity Diagrams.....	8vo,	1 50
MacFarland's Standard Reduction Factors for Gases.....	8vo,	1 50
Mahan's Industrial Drawing. (Thompson.).....	8vo,	3 50
* Parshall and Hobart's Electric Machine Design ...	Small 4to, half leather,	12 50
Peele's Compressed Air Plant for Mines. (In Press.)		
Poole's Calorific Power of Fuels.....	8vo,	3 00
* Porter's Engineering Reminiscences, 1855 to 1882.....	8vo,	3 00
Reid's Course in Mechanical Drawing.....	8vo,	2 00
Text-book of Mechanical Drawing and Elementary Machine Design	8vo,	3 00
Richard's Compressed Air.....	12mo,	1 50
Robinson's Principles of Mechanism.....	8vo,	3 00
Schwamb and Merrill's Elements of Mechanism.....	8vo,	3 00
Smith's (O.) Press-working of Metals.....	8vo,	3 00
Smith (A. W.) and Marx's Machine Design.....	8vo,	3 00
Sorel's Carbureting and Combustion in Alcohol Engines. (Woodward and Preston.)	Large 12mo,	3 00
Thurston's Animal as a Machine and Prime Motor, and the Laws of Energetics.	12mo,	1 00
Treatise on Friction and Lost Work in Machinery and Mill Work...	8vo,	3 00
Tillson's Complete Automobile Instructor.....	16mo,	1 50
	mor.,	2 00
* Titsworth's Elements of Mechanical Drawing.....	Oblong 8vo,	1 25
Warren's Elements of Machine Construction and Drawing.....	8vo,	7 50
* Waterbury's Vest Pocket Hand Book of Mathematics for Engineers.	2 $\frac{1}{2}$ × 5 $\frac{3}{8}$ inches, mor.,	1 00
Weisbach's Kinematics and the Power of Transmission. (Herrmann—Klein.)	8vo,	5 00
Machinery of Transmission and Governors. (Herrmann—Klein.)	8vo,	5 00
Wolf's Windmill as a Prime Mover.....	8vo,	3 00
Wood's Turbines.....	8vo,	2 50

MATERIALS OF ENGINEERING.

* Bovey's Strength of Materials and Theory of Structures.....	8vo,	7 50
Burr's Elasticity and Resistance of the Materials of Engineering.....	8vo,	7 50
Church's Mechanics of Engineering.....	8vo,	6 00
* Greene's Structural Mechanics.....	8vo,	2 50
Holley and Ladd's Analysis of Mixed Paints, Color Pigments, and Varnishes.	Large 12mo,	2 50
Johnson's Materials of Construction.....	8vo,	6 00
Keep's Cast Iron.....	8vo,	2 50
Lanza's Applied Mechanics.....	8vo,	7 50

Maire's Modern Pigments and their Vehicles.....	12mo,	2 00
Martens's Handbook on Testing Materials. (Henning.).....	8vo,	7 50
Maurer's Technical Mechanics.....	8vo,	4 00
Merriman's Mechanics of Materials.....	8vo,	5 00
* Strength of Materials.....	12mo,	1 00
Metcalf's Steel. A Manual for Steel-users.....	12mo,	2 00
Sabin's Industrial and Artistic Technology of Paints and Varnish.....	8vo,	3 00
Smith's Materials of Machines.....	12mo,	1 00
Thurston's Materials of Engineering.....	3 vols., 8vo,	8 00
Part I. Non-metallic Materials of Engineering, see Civil Engineering, page 9.		
Part II. Iron and Steel.....	8vo,	3 50
Part III. A Treatise on Brasses, Bronzes, and Other Alloys and their Constituents.....	8vo,	2 50
Wood's (De V.) Elements of Analytical Mechanics.....	8vo,	3 00
Treatise on the Resistance of Materials and an Appendix on the Preservation of Timber.....	8vo,	2 00
Wood's (M. P.) Rustless Coatings: Corrosion and Electrolysis of Iron and Steel.....	8vo,	4 00

STEAM-ENGINES AND BOILERS.

Berry's Temperature-entropy Diagram.....	12mo,	1 25
Carnot's Reflections on the Motive Power of Heat. (Thurston.).....	12mo,	1 50
Chase's Art of Pattern Making.....	12mo,	2 50
Creighton's Steam-engine and other Heat-motors.....	8vo,	5 00
Dawson's "Engineering" and Electric Traction Pocket-book.....	16mo, mor.,	5 00
Ford's Boiler Making for Boiler Makers.....	18mo,	1 00
Goss's Locomotive Performance.....	8vo,	5 00
Hemenway's Indicator Practice and Steam-engine Economy.....	12mo,	2 00
Hutton's Heat and Heat-engines.....	8vo,	5 00
Mechanical Engineering of Power Plants.....	8vo,	5 00
Kent's Steam boiler Economy.....	8vo,	4 00
Kneass's Practice and Theory of the Injector.....	8vo,	1 50
MacCord's Slide-valves.....	8vo,	2 00
Meyer's Modern Locomotive Construction.....	4to,	10 00
Moyer's Steam Turbines. (In Press.)		
Peabody's Manual of the Steam-engine Indicator.....	12mo,	1 50
Tables of the Properties of Saturated Steam and Other Vapors.....	8vo,	1 00
Thermodynamics of the Steam-engine and Other Heat-engines.....	8vo,	5 00
Valve-gears for Steam-engines.....	8vo,	2 50
Peabody and Miller's Steam-boilers.....	8vo,	4 00
Pray's Twenty Years with the Indicator.....	Large 8vo,	2 50
Pupin's Thermodynamics of Reversible Cycles in Gases and Saturated Vapors. (Osterberg.).....	12mo,	1 25
Reagan's Locomotives: Simple, Compound, and Electric. New Edition. Large	12mo,	3 50
Sinclair's Locomotive Engine Running and Management.....	12mo,	2 00
Smart's Handbook of Engineering Laboratory Practice.....	12mo,	2 50
Snow's Steam-boiler Practice.....	8vo,	3 00
Spangler's Notes on Thermodynamics.....	12mo,	1 00
Valve-gears.....	8vo,	2 50
Spangler, Greene, and Marshall's Elements of Steam-engineering.....	8vo,	3 00
Thomas's Steam-turbines.....	8vo,	4 00
Thurston's Handbook of Engine and Boiler Trials, and the Use of the Indi- cator and the Prony Brake.....	8vo,	5 00
Handy Tables.....	8vo,	1 50
Manual of Steam-boilers, their Designs, Construction, and Operation.....	8vo,	5 00

Thurston's Manual of the Steam-engine.	2 vols., 8vo,	10 00
Part I. History, Structure, and Theory.	8vo,	6 00
Part II. Design, Construction, and Operation.	8vo,	6 00
Stationary Steam-engines.	8vo,	2 50
Steam-boiler Explosions in Theory and in Practice.	12mo,	1 50
Wehrenfenning's Analysis and Softening of Boiler Feed-water (Patterson)	8vo,	4 00
Weisbach's Heat, Steam, and Steam-engines. (Du Bois.)	8vo,	5 00
Whitham's Steam-engine Design.	8vo,	5 00
Wood's Thermodynamics, Heat Motors, and Refrigerating Machines.	8vo,	4 00

MECHANICS PURE AND APPLIED.

Church's Mechanics of Engineering.	8vo,	6 00
Notes and Examples in Mechanics.	8vo,	2 00
Dana's Text-book of Elementary Mechanics for Colleges and Schools.	12mo,	1 50
Du Bois's Elementary Principles of Mechanics:		
Vol. I. Kinematics.	8vo,	3 50
Vol. II. Statics.	8vo,	4 00
Mechanics of Engineering. Vol. I.	Small 4to,	7 50
Vol. II.	Small 4to,	10 00
* Greene's Structural Mechanics.	8vo,	2 50
James's Kinematics of a Point and the Rational Mechanics of a Particle.		
Large	12mo,	2 00
* Johnson's (W. W.) Theoretical Mechanics.	12mo,	3 00
Lanza's Applied Mechanics.	8vo,	7 50
* Martin's Text Book on Mechanics, Vol. I, Statics.	12mo,	1 25
* Vol. 2, Kinematics and Kinetics	12mo,	1 50
Maurer's Technical Mechanics.	8vo,	4 00
* Merriman's Elements of Mechanics.	12mo,	1 00
Mechanics of Materials.	8vo,	5 00
* Michie's Elements of Analytical Mechanics.	8vo,	4 00
Robinson's Principles of Mechanism.	8vo,	3 00
Sanborn's Mechanics Problems.	Large 12mo,	1 50
Schwamb and Merrill's Elements of Mechanism.	8vo,	3 00
Wood's Elements of Analytical Mechanics.	8vo,	3 00
Principles of Elementary Mechanics.	12mo,	1 25

MEDICAL.

Abderhalden's Physiological Chemistry in Thirty Lectures. (Hall and Defren). (In Press).		
von Behring's Suppression of Tuberculosis. (Bolduan.)	12mo,	1 00
* Bolduan's Immune Sera	12mo,	1 50
Davenport's Statistical Methods with Special Reference to Biological Variations.	16mo, mor.,	1 50
Ehrlich's Collected Studies on Immunity. (Bolduan.)	8vo,	6 00
* Fischer's Physiology of Alimentation.	Large 12mo, cloth,	2 00
de Fursac's Manual of Psychiatry. (Rosanoff and Collins.)	Large 12mo,	2 50
Hammarsten's Text-book on Physiological Chemistry. (Mandel.)	8vo,	4 00
Jackson's Directions for Laboratory Work in Physiological Chemistry	8vo,	1 25
Lassar-Cohn's Practical Urinary Analysis. (Lorenz.)	12mo,	1 00
Mandel's Hand Book for the Bio-Chemical Laboratory.	12mo,	1 50
* Pauli's Physical Chemistry in the Service of Medicine. (Fischer.)	12mo,	1 25
* Pozzi-Escot's Toxins and Venoms and their Antibodies. (Cohn.)	12mo,	1 00
Rostoski's Serum Diagnosis. (Bolduan.)	12mo,	1 00
Ruddiman's Incompatibilities in Prescriptions.	8vo,	2 00
Whys in Pharmacy.	12mo,	1 00
Salkowski's Physiological and Pathological Chemistry. (Orndorff.)	8vo,	2 50
* Satterlee's Outlines of Human Embryology	12mo,	1 25
Smith's Lecture Notes on Chemistry for Dental Students.	8vo,	2 50

Steel's Treatise on the Diseases of the Dog.	8vo,	3 50
* Whipple's Typhoid Fever.	Large 12mo,	3 00
Woodhull's Notes on Military Hygiene.	16mo,	1 50
* Personal Hygiene.	12mo,	1 00
Worcester and Atkinson's Small Hospitals Establishment and Maintenance, and Suggestions for Hospital Architecture, with Plans for a Small Hospital.	12mo,	1 25

METALLURGY.

Betts's Lead Refining by Electrolysis.	8vo.	4 00
Bolland's Encyclopedia of Founding and Dictionary of Foundry Terms Used in the Practice of Moulding.	12mo,	3 00
Iron Founder.	12mo.	2 50
" " Supplement.	12mo,	2 50
Douglas's Untechnical Addresses on Technical Subjects.	12mo,	1 00
Goesel's Minerals and Metals: A Reference Book.	16mo, mor.	3 00
* Iles's Lead-smelting.	12mo,	2 50
Keep's Cast Iron.	8vo,	2 50
Le Chatelier's High-temperature Measurements. (Boudouard—Burgess.)	12mo,	3 00
Metcalf's Steel. A Manual for Steel-users.	12mo,	2 00
Miller's Cyanide Process.	12mo	1 00
Minet's Production of Aluminum and its Industrial Use. (Waldo.)	12mo,	2 50
Robine and Lenglen's Cyanide Industry. (Le Clerc.)	8vo,	4 00
Ruer's Elements of Metallography. (Mathewson). (In Press.)		
Smith's Materials of Machines.	12mo,	1 00
Thurston's Materials of Engineering. In Three Parts.	8vo,	8 00
part I. Non-metallic Materials of Engineering, see Civil Engineering, page 9.		
Part II. Iron and Steel.	8vo,	3 50
Part III. A Treatise on Brasses, Bronzes, and Other Alloys and their Constituents.	8vo,	2 50
Ulke's Modern Electrolytic Copper Refining.	8vo,	3 00
West's American Foundry Practice.	12mo,	2 50
Moulders Text Book.	12mo,	2 50
Wilson's Chlorination Process.	12mo,	1 50
Cyanide Processes.	12mo,	1 50

MINERALOGY.

Barringer's Description of Minerals of Commercial Value. Oblong, morocco,	2 50
Boyd's Resources of Southwest Virginia.	8vo 3 00
Boyd's Map of Southwest Virginia.	Pocket-book form, 2 00
* Browning's Introduction to the Rarer Elements.	8vo, 1 50
Brush's Manual of Determinative Mineralogy. (Penfield.)	8vo, 4 00
Butler's Pocket Hand-Book of Minerals.	16mo, mor. 3 00
Chester's Catalogue of Minerals.	8vo, paper, 1 00
	Cloth, 1 25
Crane's Gold and Silver. (In Press.)	
Dana's First Appendix to Dana's New "System of Mineralogy." Large	8vo, 1 00
Manual of Mineralogy and Petrography.	12mo 2 00
Minerals and How to Study Them.	12mo, 1 50
System of Mineralogy.	Large 8vo, half leather, 12 50
Text-book of Mineralogy.	8vo, 4 00
Douglas's Untechnical Addresses on Technical Subjects.	12mo, 1 00
Eakle's Mineral Tables.	8vo, 1 25
Stone and Clay Products Used in Engineering. (In Preparation).	
Egleston's Catalogue of Minerals and Synonyms.	8vo, 2 50
Goesel's Minerals and Metals: A Reference Book.	16mo, mor. 3 00
Groth's Introduction to Chemical Crystallography (Marshall)	12mo, 1 25

* Iddings's Rock Minerals	8vo,	5 00
Johannsen's Determination of Rock-forming Minerals in Thin Sections	8vo,	4 00
* Martin's Laboratory Guide to Qualitative Analysis with the Blowpipe	12mo,	60
Merrill's Non-metallic Minerals: Their Occurrence and Uses	8vo,	4 00
Stones for Building and Decoration	8vo,	5 00
* Penfield's Notes on Determinative Mineralogy and Record of Mineral Tests.	8vo, paper,	50
Tables of Minerals, Including the Use of Minerals and Statistics of Domestic Production	8vo,	1 00
Pirsson's Rocks and Rock Minerals. (In Press.)		
* Richards's Synopsis of Mineral Characters	12mo, mor.	1 25
* Ries's Clays: Their Occurrence, Properties, and Uses	8vo,	5 00
* Tillman's Text-book of Important Minerals and Rocks	8vo,	2 00

MINING.

* Beard's Mine Gases and Explosions	Large 12mo,	3 00
Boyd's Map of Southwest Virginia	Pocket-book form,	2 00
Resources of Southwest Virginia	8vo,	3 00
Crane's Gold and Silver. (In Press.)		
Douglas's Untechnical Addresses on Technical Subjects	12mo,	1 00
Eissler's Modern High Explosives	8vo,	4 00
Goesel's Minerals and Metals: A Reference Book	16mo, mor.	3 00
Itlseng's Manual of Mining	8vo,	5 00
* Iles's Lead-smelting	12mo,	2 50
Miller's Cyanide Process	12mo,	1 00
O'Driscoll's Notes on the Treatment of Gold Ores	8vo,	2 00
Peele's Compressed Air Plant for Mines. (In Press.)		
Riemer's Shaft Sinking Under Difficult Conditions. (Corning and Peele)	8vo,	3 00
Robine and Lenglen's Cyanide Industry. (Le Clerc.)	8vo,	4 00
* Weaver's Military Explosives	8vo,	3 00
Wilson's Chlorination Process	12mo,	1 50
Cyanide Processes	12mo,	1 50
Hydraulic and Placer Mining. 2d edition, rewritten	12mo,	2 50
Treatise on Practical and Theoretical Mine Ventilation	12mo,	1 25

SANITARY SCIENCE.

Association of State and National Food and Dairy Departments, Hartford Meeting, 1906	8vo,	3 00
Jamestown Meeting, 1907	8vo,	3 00
* Bashore's Outlines of Practical Sanitation	12mo,	1 25
Sanitation of a Country House	12mo,	1 00
Sanitation of Recreation Camps and Parks	12mo,	1 00
Folwell's Sewerage. (Designing, Construction, and Maintenance.)	8vo,	3 00
Water-supply Engineering	8vo,	4 00
Fowler's Sewage Works Analyses	12mo,	2 00
Fuertes's Water-filtration Works	12mo,	2 50
Water and Public Health	12mo,	1 50
Gerhard's Guide to Sanitary House-inspection	16mo,	1 00
* Modern Baths and Bath Houses	8vo,	3 00
Sanitation of Public Buildings	12mo,	1 50
Hazen's Clean Water and How to Get It	Large 12mo,	1 50
Filtration of Public Water-supplies	8vo,	3 00
Kinnicut, Winslow and Pratt's Purification of Sewage. (In Press.)		
Leach's Inspection and Analysis of Food with Special Reference to State Control	8vo,	7 00
Mason's Examination of Water. (Chemical and Bacteriological)	12mo,	1 25
Water-supply. (Considered principally from a Sanitary Standpoint)	8vo,	4 00

* Merriman's Elements of Sanitary Engineering.....	8vo,	2 00
Ogden's Sewer Design.....	12mo,	2 00
Parsons's Disposal of Municipal Refuse.....	8vo,	2 00
Prescott and Winslow's Elements of Water Bacteriology, with Special Reference to Sanitary Water Analysis.....	12mo,	1 50
* Price's Handbook on Sanitation.....	12mo,	1 50
Richards's Cost of Food. A Study in Dieteries.....	12mo,	1 00
Cost of Living as Modified by Sanitary Science.....	12mo,	1 00
Cost of Shelter.....	12mo,	1 00
* Richards and Williams's Dietary Computer.....	8vo,	1 50
Richards and Woodman's Air, Water, and Food from a Sanitary Standpoint.....	8vo,	2 00
Rideal's Disinfection and the Preservation of Food.....	8vo,	4 00
Sewage and Bacterial Purification of Sewage.....	8vo,	4 00
Soper's Air and Ventilation of Subways. (In Press.)		
Turneure and Russell's Public Water-supplies.....	8vo,	5 00
Venable's Garbage Crematories in America.....	8vo,	2 00
Method and Devices for Bacterial Treatment of Sewage.....	8vo,	3 00
Ward and Whipple's Freshwater Biology. (In Press.)		
Whipple's Microscopy of Drinking-water.....	8vo,	3 50
* Typhoid Fever.....	Large 12mo,	3 00
Value of Pure Water.....	Large 12mo,	1 00
Winton's Microscopy of Vegetable Foods.....	8vo,	7 50

MISCELLANEOUS.

Emmons's Geological Guide-book of the Rocky Mountain Excursion of the International Congress of Geologists.....	Large 8vo,	1 50
Ferrel's Popular Treatise on the Winds.....	8vo,	4 00
Fitzgerald's Boston Machinist.....	18mo,	1 00
Gannett's Statistical Abstract of the World.....	24mo,	75
Haines's American Railway Management.....	12mo,	2 50
* Hanusek's The Microscopy of Technical Products. (Winton).....	8vo,	5 00
Ricketts's History of Rensselaer Polytechnic Institute, 1824-1894.....	Large 12mo,	3 00
Rotherham's Emphasized New Testament.....	Large 8vo,	2 00
Standage's Decoration of Wood, Glass, Metal, etc.....	12mo,	2 00
Thome's Structural and Physiological Botany. (Bennett).....	16mo,	2 25
Westermaier's Compendium of General Botany. (Schneider).....	8vo,	2 00
Winslow's Elements of Applied Microscopy.....	12mo,	1 50

HEBREW AND CHALDEE TEXT-BOOKS.

Green's Elementary Hebrew Grammar.....	12mo,	1 25
Gesenius's Hebrew and Chaldee Lexicon to the Old Testament Scriptures. (Tregelles).....	Small 4to, half morocco,	5 00

Orrock	187731	TF270
Railroad structures and estimates.		08
Dec. 10 '42	Bindery	APR 14 1943
AUG 4 1943	E SCHO	SEP 6 194
AUG 10 1944	BESCHO	AUG 24 1944
Dec 12 1941	219 RES	Jan 15 '46T

187731

TF270

08

THE UNIVERSITY OF CALIFORNIA LIBRARY

