



De

Room

Shel

4,000-26



Presented to  
The Library  
of the  
University of Toronto  
by  
The Library  
Department of Transport  
Ottawa









813255

# Way and Engineering

Locomotive

INDEX FOR VOLUME XIX, 1906

(Illustrated Articles  
Marked \*)

## A

Air Brake Department, 25, 76, 121, 167, 217, 265, 325, 377, 423, 461, 515, 561.  
Air Brake Subjects:  
\*Angle Cock, Safety, 327.  
Angle Cock, Self-Locking, 516.  
\*Angle Valve with Handle Lock, 379.  
\*Air Pump, Cross Compound (3/4 ins.), 377.  
Air Brake Men's 1906 Convention, 325.  
Brakes, Testing High Speed, 25.  
Brake Pipe, Obstructions, 463.  
\*Brake Valve, Automatic, Type H, 265.  
\*Brake Valve, SF, 267.  
\*Canop, Air Brake, 123.  
\*Connections, Pipe for ET Equipment, 167.  
Convention at Montreal, 1906, 325.  
\*Compound Air Pump (3/4 ins.), 377.  
\*Distributing Valve, The, 217.  
Dukesmith Air Brake, 227.  
\*ET Equipment (Description), 75.  
\*Equipment W. A. B., New, 75.  
\*ET Equipment, Pipe Connection, 167.  
High Speed Brakes, Testing, 25.  
Hose Parting by Hand, 25.  
\*H Type, Automatic Brake Valve, 265.  
\*H-5 Brake Valve Handle, Positions of, 516.  
\*K Triple Valve, 121, 267.  
\*K Triple, Diagrams, 423.  
\*Lye Tub, Portable, 269.  
Pump Governor, S-D-4, 169.  
\*Pump, Cross Compound Air (3/4 ins.), 377.  
\*Recording Plate, Air Brake, 26.  
Pump, Large, and 100-Car Train, 561.  
Rails, Slippery, 516.  
\*Savage Safety Brake, 565.  
Strainers, Air Pump, Keep Clean, 26.  
Strainer, Air Pump, 122.  
\*Strainer, New, for Pump (W. J. Ogan), 167.  
S-D-4 Pump Governor, 169.  
\*S F Brake Valve, 267.  
\*Triple Valve, "K," 121, 267.  
Troubles and Remedies, Possible, 469.  
\*Valve Brake, S F, 267.  
\*Valve, "K," Triple, 121, 267.  
\*Valve, H-5 Brake, Positions of, 516.  
\*Valve, Automatic Brake, Type H, 265.  
\*Valve, Graduating, 470.  
\*Valve, the Distributing, 217.  
\*Z-Lock (Shriver's), 269.  
Savage Safety, 56.  
Dukesmith, 227.

## Accidents:

Cash for Railroad Prevention, 66.  
To Prevent Accident, J. W. Reading, 13.  
Railway, Angus Sinclair, Letter N. Y. Sun, 562.  
Air Pump, Tests of Compound (West'g'hs), 286.  
Alcohol, Popular Making of, 416.  
Aluminum, 48.  
\*Arched Structures, 537.  
\*Ash Handling, Economical, 29.  
Automobiles and Locomotives, Efficiency of, 256.  
\*Avalanche, Fighting the, 97.  
Axles, Crank, 466.

## B

\*Baldwin, Statue of, 305.  
Baldwin's, a Glass at, James Kennedy, 63.  
Blacksmiths, Machine, 229.  
Block Signal Legislation, 414.  
Block Signal Equipment, 549.  
Boilers:  
\*Water Tube Locomotive, for P. L. M., 463.  
Explosions, Locomotive, 368.  
Explosion, 18.  
Temperature, Favors Uniform, 66.  
Design, Essentials in, D. Van Alstyne, 209.  
Exp'dns, 288.  
Filling while being towed, 153.  
Exploding for Knowledge Safe, 359.  
Horse Power of, Roger Atkinson, 244.  
Safe, Roger Atkinson, 8.  
Washing and Repairing, 249.  
Setting Flues in Locomotives, 522.  
Brick Arch, Valve of, 201.  
\*Brake, Savage Safety, 36.  
Brake, Dukesmith, 227.  
Bridges:  
\*Black River, N. Y. C. & St. L., 161.  
\*Hascule, 296.  
\*Concrete Viaduct (Santa Ana River, Cal.), 491.  
\*Cantilever, 353.  
\*Over Schuylkill River, Pa., 193.  
\*Over St. John River, New Brunswick, 301.  
Book Notices:  
Air Brake Association, 1906 Proceedings, 462.  
American Steel Worker, R. E. Markham, 417.  
American Stationary Engineering, W. E. Crane, 566.  
Brazing and Soldering, J. F. Hohart, 509.  
Catechism of Electric Headlight, 565.

Cost of Locomotive Operation, G. R. Henderson, 509.  
Examination Questions and Answers, Marine and Stationary, 462.  
Dictionary, Car Builders', 370.  
Dictionary, Locomotive, G. L. Fowler, 556.  
Eminent Engineers, D. Goddard, 210.  
Electrical Wiring Diagram and Switchboards, Newton Harrison, 116.  
Elements of Gas Engine Design, S. A. Moss, 556.  
Electrical Dictionary, Standard, Prof. Sloane, 259.  
Gas, Gasoline and Oil Engines, G. D. Hiscox, 69.  
General Specifications for Railroad Bridges and Structures, A. W. Buel, 462.  
General Specifications for Steel Railroad Bridges and Viaducts, T. Cooper, 462.  
Link Motions, Valves and Valve Setting, F. H. Colvin, 160.  
Management of Electrical Machinery, F. F. Crocker and S. S. Wheeler, 509.  
Manual of Wireless Telegraphy, A. F. Collins, 556.  
Modern Machine Shop Construction, O. E. Perrigo, 116.  
Modern Locomotive Engineering Handy-Book, C. F. Swingle, 160.  
Notes on Patents, P. Synnestvedt, 556.  
Proceedings, Air Brake Men's Ass'n, 1906, 462.  
Practical Form Making, F. W. Barrows, 63.  
Questions Answered on Standard Code, G. E. Collingwood, 258.  
Standard Electrical Dictionary, Prof. T. Sloan, 259.  
Steel Square as a Calculating Mach., A. Fair, 556.  
Steel Square Pocket Book, D. L. Stoddard, 556.  
Signal Association Proceedings, 556.  
Tools, Second Hand, 367.  
Trests, Penna., Convenient Summary of, Dr. Goss, 372.  
Turning and Boring Tapers, F. H. Colvin, 556.  
Twentieth Century Machine Shop Practice, L. E. Brooks, 258.  
Valve Gear for Steam Engines, C. H. Peabody, 210.  
Wiring a House, H. Pratt, 462.  
Water Softening and Treatment, W. H. Booth, 371.

## C

Car Cleaning (N. Y. Club; B. P. Flory), 525.  
\*Car Design, Science Applied to, Ill. Cent., 127.  
\*Car, for Automobiles and Horses, B. & M., 428.  
\*Car (King-Lawson) Hard Service and Good Results, 575.  
\*Car Building, Rapid, in India, A. R. Bell, 412.  
Car Lines, Private, Defense of, 94.  
Case Hardening and Potashing, 381.  
Casings, Warped, 442.  
Casings, Inspecting, 351.  
Circulation of Railway and Loco. Engineering, 92.  
Correspondence School, Our, 21, 71, 117, 163, 213, 261, 321, 373, 419, 465, 511, 557.  
Collision on the I. & R. G., 159.  
Collision on the Pennsylvania, 407.  
Compass and Gyroscope, 100.  
Cost per Mile Run, J. E. Goodman, 313.  
Cuplers, More Reliable, Need, 115.  
Object Lessons on, W. E. Symonds, 157.  
\*Crank Axles, 496.  
Cars:  
\*Americas Palace Car, 200.  
\*All Steel Passenger, 414.  
\*Ballast and Sleeper Wagons, A. R. Bell, 503.  
\*Box for Automobiles, Penna. R'd, 116.  
Sanitation of Passenger, 209.  
Draft Gear, Cam Lever, for Cars, McLeod & Co., 233.  
Flat Car, Steel, for Panama Canal, 38.  
\*Flush Floor Drop Bottom Gondola, Ralston Steel Co., 314.  
\*Flat Special Steel, General Electric Co., 228.  
\*Flat, Without a Deck, Penna., 417.  
\*Flat, 100-Ton Capacity, 259.  
\*Gondola, General Service, Pressed Steel Car Co., 285.  
Gasoline Inspection, 124.  
\*Gondola, High Side Hopper (Lehigh Valley), 384.  
Repair to Steel, 564.  
\*Steel Hopper, High Side (Lehigh Valley), 384.  
\*Motor Car, Gasoline, Union Pacific, 463.  
\*Motor Coach, New (Glasgow), C. E. Morel, 494.  
\*New Form of Sleeping, 199.  
\*New Wagon Stock on British Roads, A. R. Bell, 253.  
Power Brakes on Cars, 416.  
Shortage of Freight, 564.

Side Door Car for Suburban Service, Ill. Cent., 127.  
Steel Passenger Coach for the Southern, 433.  
\*Side Dump, King-Lawson, 281.  
\*Tunnel Spray Car for Central London Railway, 380.  
Criticisms, Rational, Made Effective, 102.  
\*Curves, Elevation on Railroad, 250.

## D

Dipsomania Cures, Fraudulent, 514  
Draw Gear, Value of Friction, W. O. Thompson, 402.  
Driving Wheel Slip, Points of, 453.  
\*Dukesmith Air Brake, 227.

## E

\*Earthquake, Echoes of the, 270.  
Eccentrics, Wear of, J. E. Sweet, 14.  
Egypt Wants Railroad Equipment, 253.  
\*Electro-magnetism, Roger Atkinson, 550.  
Electrical Traction, Observations on, 552.  
\*Electric Traction on the N. Y. C., 567.  
Electricity vs. Steam, 114, 551.  
Electricity or Steam, Cost of, in Mauritius, 65.  
Electricity on Steam Railroads, Discussion by W. J. Wiggins, 177.  
Electrification on the Penna. (West Jersey & Seashore), 290.  
\*Electrification of the Simpon Tunnel, 308.  
Engine Failures, M. K. Barum, 303.  
Gear, Tractive Effort of, 128.  
Why Moves, 310.  
\*Failures and Their Causes, F. P. Roesch, 496.  
Horse Record, Scranton, Lackawanna, 234.  
Engines, Sipping, Cause of, 250.  
Some Slippery, 208.  
Derailment of Ten-Wheel, W. A. Nettleton, 341.  
\*Early Norris, W. DeSanno, 500.  
Regular vs. Pooled, C. F. Richardson, 504.  
Pooling, 293.  
Engineman, the Future, 508.  
\*Exhibits, General Foremen's Association, 295.  
M. M. & M. C. B. Convention, 238.  
Traveling Engineer's Convention, 479.  
Exhibition, the Milan, 555.

## F

Fellow Servant Law, 168.  
First Aid to the Injured, 415.  
Flexible Stay Bolts, Observation on, B. E. D. Stafford, 620.  
Flues, Leaky, Cause of, B. E. Greenwood, 259.  
Setting in Locomotive Boilers, G. G. Nicol, 522.  
Leaky, Cause of, C. Parkesen, 303.  
Foreman, the General, 414.  
Different Kinds of, 81.  
Duties of the, G. W. Keller, 287.  
Front Ends Discussed by Traveling Engineers, 506.

## G

Gas Burning, Natural, 152.  
Gears, Change, for Screw Cutting, R. Atkinson, 409.  
General Correspondence, 11, 59, 105, 151, 201, 249, 299, 361, 407, 453, 499, 545.  
General Foremen to Be Excluded from M. M. Ass'n, 318.  
General Foremen's Association, Exhibits, 295.  
Association, 252.  
Gondola, Flush Floor Bottom, 314.  
Government Ownership in Japan, 181.  
Guide, First Railway, 112.

## H

Headlights, Oil vs. Electric, A. S. Abbott, 279.  
Headlight, Light Losses from, a, 316.  
Edward's Electric, Questions on, 374.  
Heat, Train Stopping and, 191.  
Horse Power and Thermal Units, 65.  
Of Boilers, Roger Atkinson, 244.  
\*Hydrostatics in the Shop, 544.

## I

Injured, First Aid to, 415.  
Inspection During Manufacture, 568.  
Irresponsibility, 40.

## J

Joute, Value of the, 17.

## L

Leaky Flues, Cause of, C. Parkesen, 303.  
Leaky Flues, Cause of, B. E. Greenwood, 259.  
Locos, and Autos., Efficiency of, 262.

Locomotive Boiler Explosions, 268  
 Building, Establishments, Fassed Away, 194.  
 Building, Tendencies in, 16.  
 \*Front Ends, M. M. Committee Report, 330.  
 Lubricant, Grease as a, 105.  
 \*Lubricator Guard, M. Pac., 452.  
 Locomotive, Oil Burner, 18.  
 Driving Wheels Shipping, W. M. Dewitt, 546.  
 Speed, Judging, 328.  
 Locomotives:  
 \*Baldwin 2-8-2, L. C. & M., 307.  
 \*Baldwin 4-6-0 Balanced Compound, C. N. & St. L., 149.  
 \*Baldwin 2-6-2 for the Great Northern, 405.  
 \*Baldwin Track Rail for Pike's Peak, 527.  
 \*Baldwin 4-6-0 for M. K. & T., 125.  
 \*Baldwin 4-4-2, Union Pacific, 357.  
 \*Baldwin Mallet Compound for Great Northern, 472.  
 \*Baldwin 2-8-0 for Birmingham & Southern, 495.  
 \*Baldwin 4-6-2 for Oregon Short Line, 195.  
 \*Baldwin 4-6-2 for the Southern, 272.  
 \*Baldwin 4-6-2 for the Washah, 330.  
 \*Baldwin 2-6-2 for A. T. & S. F., 665.  
 \*Belgian State 4-4-0, 573.  
 \*Brooks 4-6-2 for the Monon, 79.  
 \*Canadian Pacific 4-6-2, Culm Burner, 19.  
 \*Compound 4-4-2, Great Northern of Eng., 251.  
 \*DeGhein 4-4-2 on the Pennsylvania, 289.  
 \*Electric Zone, Service in, N. Y. C., 430.  
 Electric Engines, Pennsylvania, 308.  
 Electric and Steam, 113.  
 \*Electric, N. Y. N. H. & H. R., 211.  
 \*French 4-6-0 Compound, 205.  
 Geared, Tractive Effort of, 123.  
 \*German Compound, 4-4-2 Wind Splitter, 179.  
 \*Historic, Pennsylvania, 313.  
 \*Mountain Churner in Upper Burma, 337.  
 \*Mallet Compound for the Erie, 571.  
 \*Norris, Early, W. DeSaun, 500.  
 \*Oldest in the World, W. Work, 144.  
 \*Oscillating Cylinder and no Valve Gear, E. W. Gregory, 601.  
 \*Old Timer on the Grand Truck, 459.  
 \*On the B. & O., 236.  
 \*2-6-0 P. L. M., with Water Tube Boiler, 463.  
 \*0-6-0, Great Eastern of England, 485.  
 \*Rogers 2-8-0 for Cuba, 338.  
 \*Richmond 4-6-0 for N. & W., 253.  
 \*Schenectady 2-5-0 for the B. & O., 9.  
 \*Schenectady 4-6-2 for the B. & O., 322.  
 \*Schenectady 2-6-0 for the B. & O., 172.  
 \*Schenectady 4-6-2 for the N. Pac. (Comb. Chamb.), 449.  
 \*Schenectady 2-6-6 for the B. & A., 47.  
 \*Schenectady 4-4-0 Culm Burner, D., L. & W., 224.  
 \*Schenectady 2-6-0 Culm Burner, C., D. & H., 517.  
 \*Schenectady 4-6-2 Northern Pacific, 542.  
 \*Six-Coupled Engine, Caledonian, 436.  
 \*Tank Engine, Northern of France, 479.  
 \*Texas & Pacific, 4-4-2, 372.  
 \*Three-Cylinder Compound, Great Central of England, 504.  
 \*Water Tube, for the Paris, Lyons & Mediterranean, 463.  
 \*2-4-0 on Staten Island Rapid Transit, 69.  
 Simple vs. Compound, J. F. DeBoy, 276.  
 Steam and Electric, 420.  
 Shipping of "Technology," 547.  
 Locomotive Attachments and Parts:  
 \*Bell Ringer, Pneumatic, H. Breitenstein, D. & R. G., 502.  
 \*Connecting Rod, Fork End, L. & M. E., 107.  
 \*Frame Patch, Temporary, 54.  
 \*Headlight, Glasses, Preserving, 153.  
 \*Oil Pump for Locomotives, 133.  
 \*Relief Valve, Pennsylvania, 150.  
 \*Speed Recorder and Odometer, 533.  
 \*Valves, Semi-Plug, 435.  
 \*Valve, Pennsylvania Relief, 150.  
 \*Valve Gear, Walschaerts, 519.

## M

Machine Tools, L. R. Laizure, 232.  
 Machinist's Apprentice, 461.  
 Machine Shop Practice, L. R. Laizure, 269.  
 Machinists, Modern, 317.  
 Man Who Sells Things, G. A. Post, 222.  
 Master Mechanics, Modern, 263.  
 \*McCleskey Train Order Cabinet, 420.  
 Mechanical Skill, Decline in, 53.  
 Metal, Fatigue of, 369.  
 \*Motive Power on B. & O., 336.  
 Motor, Tractive Effort of a, 252.  
 \*Carriage for Railroad A. P. Sinclair, 62.  
 M. M. Officers, 1906-07, 332.  
 M. S. N. Convention, Exhibits, 338.  
 A. C. B. Convention, Exhibits, 338.

## N

Natural Gas Buring, 152.  
 \*New South Wales, Railway Progress in, 120.

## O

Oil, Value as Fuel, 554.  
 Optical Illusion, 481.  
 Ownership, Government, in Japan, 181.

## P

\*Panama Canal, Work on the, 1.  
 \*Patent Office Department, 102, 148, 224, 288, 335, 390, 418, 510, 560.  
 Pay Increase on the Penna. System, 573.  
 Per Diem, Change in Charge, 210.  
 Per Mile, Cost of, J. C. Goodman, 313.  
 Personal, 33, 129, 175, 225, 273, 333, 335, 431, 477, 523, 569.  
 Piston, Ancient Device, 112.  
 First Use of, 57.  
 Points of View, 517.  
 Power, Expenditure of, 16.  
 And Torque, 124.

Practice, Machine Shop, L. R. Laizure, 269.  
 Portraits:  
 H. H. Vaughan, Canadian Pacific Ry., 32.  
 W. H. Wilson, Buffalo, Rochester & Pittsburgh, 23.  
 C. H. Daniels, New York Central, 24.  
 E. E. Taylor, Chicago, Indianapolis & Louisville, 35.  
 A. C. Shields, Lehigh & New England, 83.  
 W. H. Marshall, President, American Locomotive Co., 129.  
 A. W. Johnston, New York, Chicago & St. Louis, 129.  
 W. E. Fowler, Canadian Pacific, 333.  
 J. F. Deems, New York Central Lines, 333.  
 C. A. Handy, Lake Shore & Michigan Southern, 175.  
 C. M. Hays, Grand Trunk Ry. System, 273.  
 R. J. Gross, Vice-President, American Locomotive Co., 273.  
 W. C. Hope, Chief R. R. of New Jersey, 431.  
 C. M. Hurt, Boston & Maine, 431.  
 Allan McBurn, C. R. I. & P., 563.  
 The Rt. Hon., the Earl of Kintore, 33.

## Q

Questions Answered, 23, 72, 118, 164, 215, 262, 323, 375, 421, 467, 513, 559.

## R

\*Rails, Creeping of, W. Wusher, 362.  
 \*Rail Joints, Spring Clamp, 82.  
 Railway Accidents, Angus Sinclair, 502.  
 Railways, Cost of, 17.  
 Railway Disaster, British, 503.  
 \*Railway Progress in New South Wales, 120.  
 \*Steamship, 446.  
 \*Ties, Timber for, 316.  
 \*Railroad Cuts, Elevation on, 250.  
 Railroads as Merchants, 115.  
 Railroad Economy, 415.  
 \*Equipment, Egypt, Wants, 258.  
 \*Museum, France, at Purdue, 521.  
 Railroad Ties and Spikes, 462.  
 Repair Shops Savings, C. J. Crowley, 317.  
 Record Runs in 1905, 58.  
 \*Repair Yard at London, Mo., C. E. Gossett, 545.  
 \*Revolute Blue Print Machine, Everett-McAdams, 531.

## S

Safety Devices, Exhibition of, 608.  
 Safety, Factor of Transportation, 460.  
 San Francisco Earthquake, Echoes of the, 270.  
 Shop Appliances and Methods:  
 \*Air Hoist, Reliable, 22.  
 \*Acetylene Plant, D. L. & W., at Hoboken, 278.  
 \*Brake, on Shop Motor, 70.  
 \*Blow Off Valve, Locomotive, 15.  
 \*Culm Driver, 88.  
 \*Chuck, for Piston Packing Rings, 204.  
 \*Cutter and Gauge for Packing, 151.  
 \*Cylinder Head Patched, Smooth-On Mfg. Co., 530.  
 \*Crosshead Pulcrum, Frisco Shops, 134.  
 \*Crosshead Puller, W. Updegraff, 545.  
 \*Cutterhead Brake, Pennsylvania, 525.  
 \*Drill for Mud Ring, Bickford, 137.  
 \*Chuck for Flat Drills, Big Four, 493.  
 \*Useful Adjuvant for Pneumatic, 20.  
 \*Eccentric Blade Bender, 230.  
 \*Equalizer Stand, 312.  
 \*Fillets Add Strength, E. C. Landis, 543.  
 \*Safety Hanger for, 454.  
 \*Fire Box, Patches, 304, 306.  
 \*Fluesheet Cutter, Rapid, 64.  
 Flue Setting Method, 408.  
 \*Forge, Gasoline for Rivets, V. T. Kropid-Jowski, 364.  
 \*Forgings, Machine Made, C. R. R. of N. J., 46.  
 \*Grease Cup, Lever Lock, 107.  
 \*Hammer, Steam for Railroad Shops, 237.  
 \*Holder-On for Water Spaces, D. L. & W., 174.  
 Hydraulic Press, Portable, 33.  
 \*Jack Cart, 573.  
 \*Lathe, Fast Work on Old Wheel, 202.  
 \*Portable, for Bolts, 212.  
 \*Driving Wheel, Niles 90-inch, 55.  
 Boring Attachment for, 89.  
 \*And Saw Work, Good, 284.  
 \*Mud Ring, Patching a, 39.  
 \*Old Tool, Boring Driving Boxes, Penna., 437.  
 \*Packing Gauge and Cutter, 151.  
 \*Packing, Piston Rod and Valve Stem, 106.  
 \*Patches, Fire Box, 180.  
 \*Flanking, Radius, 173.  
 Reamers, Machine Shop, 153.  
 \*Scaffolding for Fast Big Four, 280.  
 \*Screw Cutting, Change Gears for R. Atkinson, 409.  
 \*Shop Sulky, or General Truck, Hocking Valley, 453.  
 \*Smoke Stack Crane, Adjustable, 393.  
 \*Stay Bolt or Stud Wrench, H. Breitenstein, 465.  
 \*Smo. Bolt Breaker, Hocking Valley, 248.  
 \*Testing, Valves, 51.  
 \*Fire Turning, Extraordinary, Geo. S. Hodgins, 36.  
 \*Ties, Clamp for Holding, 51.  
 \*Tire, Gasoline Burner for Removing, 201.  
 \*Tool Rack, Pyramid, Lehigh Valley, 162.  
 \*Truck for Wheels, "Sure Thing," 232.  
 Valve Testers, Simp. G. I.  
 \*Blow Off Locomotive, 15.  
 \*Setting by Air, 365.  
 \*Wrench for Stay Bolt, J. F. Long, 455.  
 \*Wheel-Centering Device, Adjustable, Mo. Pac., 264.  
 Schools, Free Technical, 507.  
 Shifting Winds and Cooler (Ventilation N. Y. Subways), 450.  
 \*Shops, Can. Pac., at Wainipeg, 492.  
 Shop Forces, Organization of, M. K. Barnum, 31.  
 \*Motor, Brake on, 70.

Savings for Repairs, C. J. Crowley, 317.  
 Signals, Respecting, 518.  
 \*Uniformity in, 535.  
 \*Ship, Why Big Wheels, 60.  
 Slipping, Cause of Engines, 151.  
 \*Snow Plow, Rotary, C. P. R., 171.  
 \*Sheds in the Rocky Mountains, 97.  
 Speed, Marvelous, 112.  
 Standard Time in India, 257.  
 Stay Bolts, Hollow, 407.  
 Bolts, Flexible, B. E. D. Stafford, 520.  
 Street vs. Iron, 429.  
 \*Steel Arch at Niagara, 537.  
 Steam Gages, Historical, 82.  
 vs. Electricity, 114, 551.  
 Surprise Tests, 49.  
 Stories and Sketches:  
 Air Brake Train, First, S. J. Kidder, 500.  
 Buldozer's Bluff was Called, Shady Maguire, 187.  
 European Notes and Comment, A. F. Sinclair, 5.  
 Notes and News, British, A. F. Sinclair, 103.  
 304.  
 Old Time Railroad Reminiscences, S. J. Kidder, 539.  
 Shady Maguire Seeks Headmen, 234.  
 Small Fractions and Big Money, A. O. Brooks, 549.  
 Unloading, A. O. Brooks, 412.  
 Why Johnson Wasn't Fired, B. Marks, 356.  
 You Can Search Me, A. O. Brooks, 183.

## T

Tools:  
 \*Blue Print Machine, Everett-McAdams, 531.  
 \*Cutting-Off Machine with Taylor-Newhold Saw, 339.  
 \*Cylinder Boring Machine, Barrett Co., 295.  
 \*Milling Machine, Plain, Becker-Brainerd Co., 294.  
 \*Milling Machine, Portable, Underwood, 234.  
 \*Molder, New Inside, Fay & Egan Co., 45.  
 \*Old Ring, Drill, Bickford Co., 337.  
 \*Resaw for General Work, Fay & Egan Co., 350.  
 \*Sander, Triple Drum, Fay & Egan Co., 441.  
 \*Conqueror, Fay & Egan Co., 136.  
 \*Saw, Band, Rip and Edging, Fay & Egan Co., 522.  
 Saw, Band, Rip and Resaw, Fay & Egan, 233.  
 \*Thread Rolling Machine, Acme, 81.  
 \*Wheel Press, Hydraulic, 600-Ton Capacity, Niles-Bemont-Pond, 483.  
 Temperature, Uniform Bolt, Favors, 66.  
 \*Terminal, Clearing for Penna. in New York, 295.  
 Tests, Compound Air Pump (Westinghouse), 286.  
 Surprise, 49.  
 Bending, Defective, 54.  
 Locomotive, Pennsylvania, 139.  
 Time, Standard, in India, 257.  
 Ties and Spikes, Railroad, 462.  
 \*Touch and Living Fence Posts, 81.  
 Timber for Railway, 316.  
 \*Tire Turning Extraordinary, Geo. S. Hodgins, 38.  
 Torque and Power, 124.  
 Traction, Electrical, Observations on, 552.  
 \*Traction, Electric, on the N. Y. C., 567.  
 \*Track Appliances, Hays' Pivot Drill, 577.  
 \*Traveling Engineers' Ass'n, Account of Meeting, 456.  
 \*Train Shed, Smokeless, D. L. & W., Hoboken, 352.  
 Train, 100-Car and Large Pump, 561.  
 Stopping and Heat, 101.  
 Train, Stopping a Moving, 572.  
 Train, The President's, 114.  
 \*Stopping, Automatic, 45.  
 \*Orders, Cabinet for (McCleskey's), 420.  
 Trains, Large, and Small Boats, 553.  
 Tractive Effort of a Geared Engine, 123.  
 \*Traveling Engineers' Convention, Exhibits, 475.  
 \*Traveling Engineers' Convention, Exhibits, 475.  
 Engineers' Association, 460.  
 Engineers and Front Ends, 500.  
 Trade Unions, 209.  
 \*Trucks, Boltless, W. E. Symons, 438.  
 Transportation Factor of Safety, 460.  
 Transportation and Advertising, 552.  
 Tunnel, St. Clair, Electrification of, 74.  
 \*Tunnels, Under the Hudson River, Penna., 616.  
 \*Driving a, 241.  
 On Erie, 505.  
 \*Simplem, Electrification of, 308.  
 \*Spray Car, Central London Ry., 380.

## U

Units of Measurement, Odd, 145.

## V

\*Valves and Valve Motion, Development of, 400.  
 Angus Sinclair, 103, 154, 196, 246.  
 \*Valve Gear, Ancient Cut-off, W. DeSaun, 365.  
 Walschaerts, James Kennedy, 165.  
 Walschaerts, 281, 519.  
 \*Motion, Joy's, 55.  
 \*Valve Setting by Air, 365.  
 \*Ventilation of New York Subway (Shifting Winds and Cooler), 450.  
 \*Walschaerts Valve Gear, James Kennedy, 166.  
 \*Valve Gear, 281, 519.  
 Watchman, the Night, 555.  
 \*Westward for the Far East (Overseas Limited, C. P. R.), 461.  
 Waterfall, Engulfing A, 201.  
 Why Do It That Way? 357.  
 Wise Eyes Are Odd, 470.  
 Wrong, To Right a Helious, 153.

## Y

Yard Clerk, Hardworked, 146.



# Railway and Locomotive Engineering

Copyright by Angus Sinclair Co.—1905

## A Practical Journal of Railway Motive Power and Rolling Stock

Vol. XIX.

136 Liberty Street, New York, January, 1906

No. 1

### Work on the Panama Canal.

The shortest route for the canal would have been across the Isthmus of Darien, using a portion of the San Blas river. This would have connected the oceans by a waterway about 30 miles long. To

would have involved the dredging of a lake 110 ft. above sea level.

The Panama route is 46 miles from shore to shore, and as the French company had excavated about one-fifth of the canal, and for other

These had been filled with water for twenty years, and as they were only dug 28 ft. deep, they will require dredging to make them deep enough for modern requirements.

When the Isthmian Canal Commission



CULEBRA CUT, THE LARGEST EXCAVATION ON THE ROUTE OF THE PANAMA CANAL.

do this, however, a mountain 1,500 ft. high and about 5 miles through would have to have been tunneled, in a way suitable for the passage of modern steamships. Such a tunnel driven through probably shaly or volcanic material would require lining, and this, and the fact that the ship canal would have been 150 ft. above tidewater made a longer but surer way the one chosen. The Nicaraguan route is 137 miles long, and

reasons, it was decided upon by the United States Government. The rights of the French company were purchased for \$10,000,000, and the work undertaken by the Isthmian Canal Commission. At the time of this purchase a sea level canal on the Atlantic side extending from the city of Panama to Bohio, a distance of 16 miles, was in existence. On the Pacific side there was a 5 mile canal from La Boea to Miraflores.

took charge in 1904 they assumed a gigantic task which involved not merely the excavating and disposing of the material, but the sanitation of the entire Canal Zone and the cities of Panama and Colon, the organization of the different branches of the enterprise, and the importation of labor. The work of sanitation is now being so well done that life and health are preserved, where formerly hundreds succumbed to yellow fe-

ver. The French placed at the foot of each selected tree a metal basin of water and planted numerous flower gardens; they thus harbored and increased the activity of the mosquito, but to-day a visitor may see all the undergrowth cut away and a bare spot taking the place of the French garden, but there is health, a prime factor in such a work as this.

excavating machine consisting of a system of buckets on an endless chain and working beneath its own level. This machine was only able to handle material after it had been blasted, and it has given place to the modern American steam shovel of 70 and 90 tons, which at one rise of its boom and dipper tears away from the sides of the bank

magnitude of these supplies one has only to read over the summary of the principal items. This includes 61 steam shovels, 1,300 flat cars, 12 rapid unloaders, 22 unloading piers, 13 earth spreaders, 324 dump cars, 12 hoisting engines, 120 locomotives, 5,000 tons of steel rails, 125,000 cross ties, 12,000 pieces of piling, 14 air compressing machines, 3 cranes, 152 rock drills, 30,000,000 ft. of lumber, 2 dipper dredges, 646,000 lbs. of blasting powder, 617,500 lbs. of dynamite, 7,000,000 paving brick, 3,500,000 building brick, 500,000 sq. ft. of roofing tile, 36,000 barrels of cement, 3 steel water tanks and towers, 12 standpipes, and 2 ocean steamships. The approximate total cost of all this is about \$9,000,000.

As to actual excavation and dredging on the canal, Mr. Schonts says: "We are now working six steam shovels in Culebra cut, which is the largest single factor in the construction of the canal, and have removed approximately one million cubic yards of material. By this work we are accomplishing two things: First, we are putting the levels of the cut in proper condition for the installation of the largest number of machines which can be effectively operated; and, second, we are gathering data which will be useful in future estimates of the cost of canal construction. On the Culebra work 2,600 men are now employed. We are also building railway tracks and yards, and are dredging at both ends of the canal, so far as advisable until the question of type of canal is decided."

The dredging now being done is suita-



METHOD OF DOING THE WORK ON THE PANAMA CANAL.

The purchase which the President made under the Spooner Act of 1902, was not only the two stretches of canal to which we have referred, but also the Panama Railroad, with such shops and machinery as were formerly owned by the French company. It has been intimated by Mr. Schonts, chairman of the Commission, that this road, with its docks, wharves, warehouses, yards, etc., is the only thing essential to the construction of the canal which has been acquired by this purchase, but long neglect has greatly deteriorated the value of the equipment and time has rendered much of it obsolete.

One of the greatest obstacles in the work of preparation has been the relaying of the entire system of tracks for the canal work. The existing tracks are all 5 ft gauge to correspond to that of the old Panama Railroad, and were originally laid on steel ties, the rails being about 60 lbs. to the yard and nearly 5 in. high, with a base of only 4 ins. When the Commission first undertook the work there was an attempt made to use these rails on wooden ties, but they were found to be satisfactory, as they readily turned over when loaded and cut into the ties to such an extent that they were almost useless even under the old Belgian locomotives, and they could not possibly stand up under the increased weight of new equipment.

The French used in their work an

from 3½ to 5 yards of material. The French used in their transportation a Belgian engine and a steel dump car of five yards capacity, dumping only one way. These old engines are about 30 tons weight, and were built on a solid frame. They have steel cabs with saddle tanks. They have three drivers on a side, 47 ins. diameter, cylinders 15¾x19 ins., and a wheel base of 8 ft. 7 ins. These Belgian engines are entirely too small to do the work now required and they are being replaced by engines built by the American Locomotive Company, illustrated in our December, 1905, issue. Some of these locomotives have already arrived on the Isthmus and are being erected in the Colon yards.

The old French dump car is being replaced by a modern air equipped steel car, dumping either right or left, weighing approximately 43,000 lbs., and having a capacity of about 100,000 lbs. There are also a number of steel flats now in use built by the Standard Steel Car Company, illustrations of which will be found in another column. These cars are used in the handling of materials and supplies on the Panama Railroad and Canal tracks.

While work is going on the task of purchasing, forwarding and distributing the enormous quantity of materials and supplies of all kinds is receiving constant attention. To gain some idea of the



A MISHAP IN THE CANAL ZONE.

ble to any type of canal. The question as to type yet to be decided is, shall it be a lock canal or an open sea level one?

The work is of great and worldwide importance and worthy of the nation's enterprise. It is in the western hemisphere and it has fallen to the lot of the United States to do the work, to main-

tain the neutrality of the canal zone, and open a waterway to the shipping of all nations. The canal is to be free, which means that although a toll will be charged for the passage of any ship through it, there will be no discrimination in favor of any nation or against any

### Jim Skeevers Explains a Principle.

BY JOHN A. HILL.

Skeevers' fireman, Billy, has been "sot up" a fortnight now, and the Old Man put Mike Kelly on with Skeevers.

It's Mike's next turn to do the "touch the button, the fireman does the rest"

propensity for never going to bed until the last cat is hung, and then hating to keep awake the next day.

Mike, in common with other mortals, must suffer the ills of his inheritance; but Mike, and all the rest of us, suffer more from the desires, habits and practices that environment has established than from inheritance — or anything else.

Mike didn't get the right kind of an engineer to start with, so now, after firing four years, Mike knows a lot of things about locomotives that are not so, and has learned a lot of things that he must unlearn, and formed a lot of habits that must be broken.

Perhaps the Old Man knew this, and put the job onto Skeevers, and blames Mike and his first engineer; but why didn't the Old Man tumble to all this three years ago, before Mike's crooked habits got "set," so to speak? These Old Men make lots of curious engineers out of firemen of their own selection, and then go off and kick about them—but that's nothing to do with Skeevers and Mike.

Mike's worst habit, as it struck Skeevers, was sleeping on the engine. Skeevers is down on that; he knows that it is dead wrong, to begin with, and Skeevers carries a big scar that he got one night, a long while ago, when he was firing for a man who slept on duty; the man has slept ever since—in a graveyard. That was an object lesson to Skeevers, and Skeevers maintains



CULEBRA CUT LOOKING NORTH. PANAMA CANAL.

in the use of a waterway which has been practically dedicated to the uses of civilization.

### Harnessing Necaxa.

A new water-power plant in Mexico, which will eventually utilize a fall of nearly 3,000 ft., is now in course of construction at the Necaxa Falls, about 100 miles northeast of the City of Mexico. It will eventually supply the capital with electric power, and the excess current will be carried 71 miles farther, to the El Oro mining district. The final capacity of the plant will be not less than 80,000 h.p. Plant No. 1, utilizing a drop of 1,470 ft., is now practically completed.

### Nest in a Railway Car.

The station master of Lassigny was walking beside a train that was filling up prior to starting, when he suddenly heard a chirping from one of the freight cars, says the *London Bystander*. Looking closer, he perceived just beneath the floor of a car a nest containing five tiny birds not yet covered with feathers, but whose wide-open mouths demonstrated their anxious desire for food. The station master presently saw the mother, a nightingale, bringing food to her offspring. The mother bird, which at first traveled with her children on the car, and was tireless in her attentions, now remains at Lassigny, and every time the train comes to the station she reappears with her beak full of dainties.

act, and the Old Man thinks Skeevers a good runner to graduate the boys.

Skeevers is no hog; he knows that Billy is the best fireman on the road, and did lots of his work, and that the next



OLD FRENCH MACHINERY ABANDONED ALONG THE CANAL ROUTE.

fellow will make it harder for him, but he's been thinking of Bill some, and rejoices in his promotion—he has an interest in his success.

Mike was born with a constitution that could stand worlds of rest, and probably he also inherited some of his

that one good object lesson is worth more than two books, or four or five hundred "tellings." So Skeevers concluded to give Mike a few object lessons on sleep, and how not to do it on an engine.

Skeevers pulls fast freight, generally

having enough refrigerator cars or fruiters ahead to handle the train with air. The division is long and hilly; some places the train will run for eighteen or twenty miles.

The first trip out Mike attended to his duties pretty well, but got dozy on

"I told you to look out, and not let me go to sleep; I believe you were asleep yourself."

"No, sir; I was drowsy, but not asleep."

"Not asleep? well, you had your eyes shut."

over near town, and Mike told him about it, and the gaffer said they had orders to meet "Three" at Sand Creek, and no "do not" at Ford's. Mike accused Skeevers of "playing smart," and Skeevers asked Mike how different it would have been had the case been genuine.

A few trips later Mike started a snooze in good shape, and Skeevers quietly let the "48" drift against a slight grade and stop, steam low. In twenty minutes the conductor came over, swung up into the gangway, and asked Skeevers what was the matter with the "48."

"Nothin' at all," said Skeevers; "nothin' at all, but the fireman is worn out for sleep, and has laid off; I have no fireman."

Mike was awake then, and heard the talk.

"I ain't paid for firing or keeping the fireman on duty," continued Skeevers; "if Mike wants to lay off, it's his business and the Old Man's—not mine. I won't run without a fireman, though—not a mile."

The conductor consulted his watch. "Can't get to Sand Creek for 'Three' now; what'll I say was the cause of delay?"

"No fireman," said Skeevers.

The conductor went back over the train, and Mike nursed his wrath a while, and then turned loose:

"Skinny Skeevers, how long you goin' to work this racket, and make such a



OLD FRENCH EXCAVATOR AT WORK.

the long stretches between fires; but the second trip he went fast asleep, and Skeevers had to wake him up to get over Waxem hill.

The next night they had to double out, and as soon as they pitched over for a ten-mile run Mike fixed up his fire a little, and sat down.

"Mike," said Skeevers, "don't let me forget; I have orders not to pass Ford's without orders—don't let me go to sleep."

"All right, Skeevers," said Mike; "where do you meet 'Three'?"

"At Ford's," said Skeevers.

Mike closed his eyes directly, just to rest 'em a little; then he looked around, owl fashion, kind of thought he saw his best girl ahead of the engine, nodded to her, made a profound bow, and—was off. The engine? No, no; off to sleep—"pounding his ear," Mike calls it.

Skeevers sailed by Ford's, and took the siding at Sand Creek, all "unbeknownst" to Mike.

When "Three" thundered by, Mike jumped up, put in a fire, and asked Skeevers if he had his orders yet.

"What orders?" asked Skeevers.

"That 'do not' at Ford's."

"We're by Ford's, and I didn't get the orders," said Skeevers, in an awed tone of voice; "it's a wonder we didn't hit 'Three'."

"You're in for it, Skeevers, I guess."

"So are you."

"Not much; I'm no bold engineer."

"Yes, but it wa'n't sleep."

"What was you thinking about when we passed Ford's?"

"Nothin'."

"Well, Mike, if you shut your eyes



MODERN STEAM SHOVEL CUTTING DOWN A BANK.

and stop thinking, it comes nearer being sleep than anything I know of. We'll probably get fired or get ninety days for this."

Mike was wide awake the rest of the way in, but Skeevers appeared glum and downhearted. The head gaffer came

darned fuss about a man's dozin' a little, and reportin' every little thing?"

"Just as long as you sleep on duty, Mike," said Skeevers; "I won't run a rod with you when you are asleep; I will stop just as quick as you shut your eyes, let the circumstances be what they

may. I shall not let the conductors lay any such delay to bad coal or leaky flues. It must all be charged up to 'No fireman.' If you stay on the road, you will soon be running an engine here, and if you sleep on duty now you will then, and it will all end in your killing

grant them to you." And they all went away satisfied.

#### Platinum the Most Precious Metal.

The world's total supply of platinum during the year 1904 was, according to the *Electrical World*, about 13,860 pounds,

#### European Notes and Comment.

BY A. F. SINCLAIR.

THE LIEGE SHOW.—It may not be known to all the intelligent readers of this interesting publication that there is at present running in the city of Liege, Belgium, a very important exhibition, in which locomotives and railway rolling stock cut no small figure. It is not my intention at present to go into details regarding this exhibit, beyond referring to their tendencies in some respects. In the first place, notwithstanding the extent to which compounding has been attempted in France, there are remarkably few engines of that kind shown, either by locomotive constructing firms or railway companies. Another point in which not a little interest centers is the very general use of superheaters of one kind or other on Belgian engines, mostly of the simplified Smidt type, in which the superheater tubes are placed in the flues. As a consequence to some extent of the use of superheated steam piston valves have been adopted and are fitted on a number of French engines, although others using the hotter form of steam are constructed with the ordinary D slide valve. A good many are equipped with electric lighting plants, a set of which, taken from *The Engineer*, is shown below.

This mechanism is placed on top of the boiler, between the dome and the cab-front on one of the Belgian state



DISPOSING OF MATERIAL TAKEN FROM THE CANAL.

yourself, and perhaps some one else—very likely me. If you stay on the road, and on this engine, I will break you of sleeping—you are liable to be fired any day for good cause, however."

Mike kicked some, all to himself; but he is keeping awake pretty well, and if Skeevers just lets a little air out of the brake valve now, Mike will straighten up, and say:

"Oh, I ain't asleep, Skinny; bet your neck I'm all right."

Skeevers says it will take six months to make a permanent cure, and remove the tendency of fatal symptoms to return; but Skeevers says he'll fetch him, and still has an abiding faith in object lessons.

#### Rate Makers Have No Clear Plans.

The celebrated Louisville editor, Henry Watterson, does not feel inclined to throw his great influence on the side of the politicians who are striving to pass a railroad rate regulating bill. Mr. Watterson insists that the people do not understand what they want in the way of railroad rate control.

In the course of a conversation about the troublesome rate question, Watterson was reminded of a story of a Spanish Premier who was appealed to by a mob of workmen with real or fancied grievances. The Premier stuck his head out of a window, and asked, "What do you folks want?"

"We demand our rights!" they shouted.

"Very well," replied the Premier, "I

13 200 pounds of which came from Russia. The United States produced 200 ounces, valued at \$4,160. All of this came from California and Oregon, the Wyoming mine having suspended oper-



ERECTING A STEAM SHOVEL ON THE GROUND.

ations. The price of platinum increased 10 per cent. during the year. According to Dr. David T. Day, of the United States Geological Survey, the outlook for an increased production during 1905 is good. The present price of platinum—\$20.50 an ounce—is the highest which this metal has reached in recent years.

engines constructed by the Société Anonyme La Metallurgie, Tubize. The vertical engine is a single-acting high-speed machine with a direct drive to the completely enclosed dynamo shown. This set lights the train and engine with a minimum of attention. The connections between the vehicles are sim-

ple yet secure, with a slip-joint for emergencies.

ACCIDENTS ON BRITISH RAILWAYS.—A writer in the *St. Louis Daily Globe-Democrat* has contributed an article to his paper on this subject, in which he attributes all sorts of nefarious practices to British railway managers, and to the Board of Trade for the suppression of publicity regarding accidents. The article has attracted attention, hence this reference. By some curious distortion of figures and misconception of facts the writer proves to his own satisfaction that more lives are lost by railway accidents in this country than in the United States. He refers, for instance, to the Board of Trade returns for 1901, in which it is shown that only one passenger's life was lost in the United Kingdom during that year from railway accidents, and he goes on to state that in that year one passenger was killed in Britain for every 924,000 carried, while in the United States only one passenger

these inspectors, the Board of Trade returns are based, and their completeness and accuracy are beyond question. It is, of course, somewhat difficult for a resident in a den of boodle and graft to appreciate the existence of honorable and efficient civil servants, but I can assure the writer that the Board of Trade inspectors are both.

THE ELECTRIFICATION OF RAILWAYS.—The introduction of electricity for motive power on British railways proceeds with steadiness if not exactly with rapidity. A notable addition to the number of lines using this power is the London Metropolitan District and District railways. These lines are almost entirely under ground, and serve an enormous area of the English metropolis, circulating within its precincts and sending branches in various directions as feeders. They were probably without exception the dingiest and most stiffling stuffy railways in the world till recently, and the smells deposited

reward to the enterprising improvers. Another railway on which steam has to give way to electricity is the short line from Newcastle to Sunderland, on which the North Eastern Company have just decided to make the change.

PISTON VALVES.—These valves were used in the early days of locomotives—so long ago as 1833, I believe—but they fell into disuse, although it is not very clear why. Since that time they have had occasional periods of—recrudescence, shall I call it—but have always dropped into the background. Now they are coming into use again, and without any particular reason, so far as I can see. There was a suggestion that the use of superheated steam might be the cause, but both the D and piston valves suffer equally from the use of stuffing boxes, and the remedy—against the use of packing—the fitting of mushroom valves, is, of course, absurd. The point, however, is that piston valves are coming into use for simple engines using a simple boiler, while the compound with superheater in some cases retains the ordinary D slide valve. Inquiries made on the roads where they are used have failed to discover any superiority either way, both performing their work with equal efficiency.

AN EIGHT-HOUR DAY.—The General Federation of Trade Unions is a body exercising great influence in industrial societies in this country, and it is somewhat significant to find in its twenty-fifth quarterly report a tacit admission that the movement in favor of a universal eight-hour working day has failed. This movement was at its height a few years ago, and it has certainly subsided with remarkable celerity. The labor leaders were, it is now believed, too extreme in their demands, and their claim that every one should be compelled by law to cease work for that day at the expiration of eight hours' labor no doubt alienated, from its absurdity, the sympathy of many of their own followers. The appeal is now made to secure an eight-hour day by mutual arrangement between employers and employed, and it claims that the rapidly increasing production resulting from the general adoption of labor-saving machinery justifies the institution of a shorter day. The report, in referring to the fact that 5 per cent. of the members of trade unions are unemployed, holds that the remedy lies in the adoption of a shorter day, but one which shall be elastic enough to prevent chronic unemployment while rigid enough to prevent systematic overtime.

A WATER-TUBE FIRE BOX.—It is rather a departure to have the term "water-tube" removed from its legitimate position in the boiler to do duty in the fire box. The originator of the change is Mr. Brotan, workshops superintendent

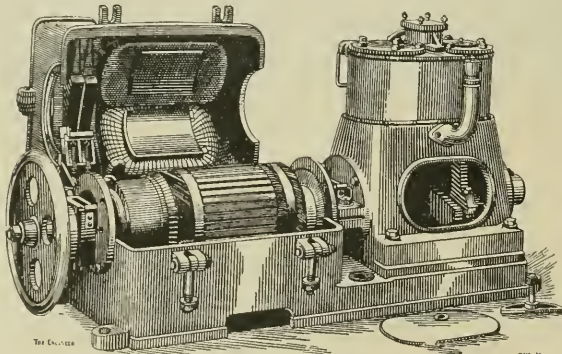

A LOCOMOTIVE LIGHTING PLANT.

(From *The Engineer*, London.)

was killed to every 2,129,382 carried. The writer has got mixed up between people killed on railways and those killed by accidents to trains; and his suggestion that the Board of Trade figures are the result of improper returns blindly accepted only makes one smile. Railway accidents are watched by the Board of Trade inspectors with the keenest attention, and not a single passenger's life is lost by accident to a train without a searching inquiry into the cause. Accidents of the kind cannot be suppressed in Britain. First, there is the Coroner's inquest and his return; then follows a Board of Trade inquiry and the inspector's report. These inspectors are officers of the Royal Engineers, men of the highest probity, and a type of man somewhat difficult, perhaps, for a St. Louis journalist to understand. On the accounts furnished by the railway companies—who are bound by law to supply them—verified by

by many thousand layers of sulphurous smoke will take years to eradicate. However, the proper man came along, and seeing a lucrative investment in view, he bought up largely of the stock until interest and influence sufficient to have his own way were gained; then he said steam power must go. His name is Yerkes; Yerkes, of Chicago tramways, of St. Louis, and elsewhere. Having decided on electricity as power, he came north to Glasgow, with his millions to back him, and seduced away our tramway manager, John Young, to whom, far more than to James Dalrymple—who was in America last summer, advising Chicago on the subject—the success of the Glasgow tramway system is due. That the electrification and brightening of the London Undergrounds—as they are popularly called—will be a very great benefit to the urban and suburban traveling public is certain, and not less sure will be the financial

of the Austrian State Railways. Like many others holding similar appointments, Mr. Brotan has found copper fire box walls both expensive and, from the nature of the metal, easily damaged. A number of years ago, therefore, he began experimenting with tubular walls, and for four and a half years he has secured very satisfactory results. The tubes, which are of seamless steel, are set upright, with their ends rolled into a cast-steel pipe, and are arranged in rows .078 inch apart. They form the boundary at the sides and rear of the fire box, from which the gases escape through an iron tube plate into the fire tubes of the boiler. The upper ends of these tubes connect with the steam space of a second boiler placed above the main one, the two being connected by means of these openings. For this form of fire box it is claimed that it burns fuel better, consequently steams better, and, as it is about half again as large as the usual fire box, there is more uniform draft. In official trials the results are said to have been great steaming power, dry steam, fuel economy, and rapid heating.

#### An Irish Foreman.

A machinist's helper, a native of the Green Island, was promoted to the position of foreman of laborers, and, full of importance, he looked around to discover an opportunity of showing his authority. The shop sweeper happened to come along. "F'wat are yez doin'?" inquired the newly appointed superior officer. "I'm wheeling a barrow," replied the sweeper. "Put it down," said the boss laborer, "and go and get a shovel. F'wat does the likes o' you know about machinery?"

#### Idea of Artificial Ice Making.

The development of the ice-making machine deserves a place among the romances of industry. Like a great many other important scientific discoveries, the idea of making ice by mechanical means originated in Scotland. The economical production of cold by the combustion of fuel was long a matter of theory described by scientists in different countries. It remained a mere theory until, in 1755, Professor Cullen experimented in Glasgow with quicklime and spirits of sal-ammoniac as the best volatile combination for producing cold. He demonstrated plainly enough that the operation could be performed, even to the extent of producing artificial ice; but his discoveries remained as laboratory experiments until Jacob Perkins, a native of Newburyport, Mass., in 1834, obtained a partial success in producing ice by the evaporation of ether.

#### Origin of a Familiar Word.

People interested in the origin of names of things, derive a good deal of pleasure in their researches and often bring interesting facts to light. It seems that the delvers into the forgotten things of the past have come across the probable origin of the familiar word "boss," which is constantly used in railroad parlance.

The word "boss" is said to be derived from the Dutch word "baas," meaning an overseer or master workman, and was so used in this country as early as 1615, and was found in the speech of people in the North and East, and particularly in New York. It was then applied to all trades, or, more correctly, to the handicrafts, and signified a master workman. It is used in its original signifi-

cation. "Oh," replied the man with through rates at his fingers' ends, "that is our road, sir, the Rock Ballast & No Dust Route." "And that other," continued the mild man, "that hardly discernible spiral line which passes through what appears to be barren land; is that a gently flowing rivulet or stream?" "That," said the A. G. P. A., gaily, "is the outline of the road which puts up a weak and ineffectual bluff of competing with us, sir—our competitor—ha, ha, ha!—the Doolittle, Devious & Delayful Line; it takes a month to do what we do in a day."

#### The Law's Delay.

Some time ago one of the leading roads in the Middle West was the defendant in a suit for damages brought by

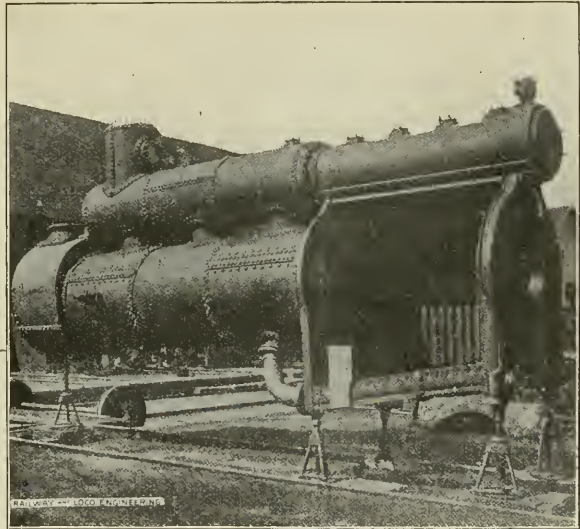

WATER TUBE FIRE BOX.  
(From *The Practical Engineer*.)

cance when we speak of a gang boss in a railroad shop or a section boss on the road.

The word has now, however, a wider application and is used in party politics. It has also been made to do duty as a verb, as in the expression, "He bossed the job." The word is short and easily said, and this, no doubt, accounts for its popularity.

#### Art of Map Making.

"What is that heavy black line drawn. I doubt not, with the aid of a ruler, which I see on your map, connecting those two important and populous cities, and having the names of all the thriving towns in the State lying along it?" asked a mild mannered stranger of the young and hustling assistant general pas-

senger agent. "Oh," replied the man with through rates at his fingers' ends, "that is our road, sir, the Rock Ballast & No Dust Route." "And that other," continued the mild man, "that hardly discernible spiral line which passes through what appears to be barren land; is that a gently flowing rivulet or stream?" "That," said the A. G. P. A., gaily, "is the outline of the road which puts up a weak and ineffectual bluff of competing with us, sir—our competitor—ha, ha, ha!—the Doolittle, Devious & Delayful Line; it takes a month to do what we do in a day."

The action was eventually tried in the Supreme Court of the United States and the verdict of the lower court was affirmed. The Supreme Court also awarded 10 per cent. additional damages with interest and costs.

The press dispatch containing information concerning this case says that the action of the Supreme Court has administered a severe blow to the policy of using delay as a means of tiring out the plaintiff in a personal damage suit. This ruling by the Supreme Court is said to be almost unprecedented.

### Safe Boilers.

BY ROGER ATKINSON.

The only absolutely safe boiler is one which carries no pressure.

So long as steam is used as a medium for the conversion of the potential power contained in coal or other fuel into the motive power of machinery, it is probable that, like the poor, we shall have steam boilers with us. The steam boiler as a means of furnishing pressure has been invented and improved side by side with the engines of various types which have been invented to use that pressure, and, like guns and armor plate, alternately one or the other has been ahead in development. The boilers which were built to supply steam for Newcomen's pumping engines were only required to carry atmospheric pressure, and the power was developed entirely by condensation.

Some of the original boilers were shaped like a common tea kettle, being circular, with arched bottom, sloping sides and round top, and the safety valve was a loose plug on the top of a short pipe. The writer was informed that such a boiler was, some 30 years ago, still in operation near Wellington, in Shropshire, England, and used for driving a pumping engine of the Newcomen type.

The next development was to still apply the fire outside, but to construct the boiler with one or more large flues for the hot gases to pass through. Then the small return flues were introduced. Later, as the engine was improved, so the boiler was designed to be as safe as they then could be made for pressures up to about 60 to 80 lbs., where progress stayed in some classes, such as marine engines and condensing engines generally, for a time.

This was principally due to the method of applying the heat to the boiler. It has been found by experience that it is not advisable nor safe to have the heat of the fire directly applied to plates which are over  $\frac{1}{2}$  in. thick, as the thicker plate will burn and sag down or crack, it not being able to transmit the heat quickly enough. If the boiler is a common multitubular return-flue boiler, with the fire below, the shell is limited to that thickness, and therefore it was found that the diameter of the boiler was limited to about 72 ins. or less, with the common double-rieveted lap joint having about 56 per cent. of the plate strength. This limitation was overcome by the development of the internally fired boiler, such as the Lancashire boiler, for land service, and the Scotch boiler, for marine purposes. As the fire is not applied to the shell plates, it was possible to use the thickest plates which it was possible to manufacture, and the joints of the fire box or flue

sheets were practically not affected by the fire when placed below the grate. In the meantime the locomotive had been invented, designed to use high-pressure steam, as it was called, that is, it was not a condensing engine.

For locomotive purposes, as the condensing system was not applicable, it was necessary to use, and design, boilers to carry higher pressures than were common in marine and land service, so that boilers carrying pressures up to 120 lbs. soon began to be designed for common practice. This was partly due to the fact that large cylinders could not be carried and to use low pressures required too large a boiler; consequently the only available means of getting more power was to increase the pressure. At the same time, this permitted the boiler to be kept small in diameter, and therefore the same thickness of plate would give a higher factor of safety. It should be noted that all prevailing types of boilers at that time in marine and locomotive service, that is, service where the boiler is in motion from place to place (and also the most successful of the stationary type from an economical point of view), were of the internally fired type, and all which had flues or tubes, had the smoke and flame passing through them internally. The rapid development of the locomotive type boiler was partly due to the first examples being of the internally fired type and the early application of the tube principle.

When the unsafe types, such as the lap-jointed, weak iron angles, stays and freaks, were weeded out by experience, those which survived soon began to be designed and built to carry 140 lbs., and even 160 lbs. in locomotives, and perhaps 80 lbs. to 100 lbs. in stationary and marine practice, by careful design and good workmanship, but they had practically reached their safe limit with iron plates, even of the highest quality. These increases of pressure were adapted to, and rendered successful, the two-cylinder compound engine in marine service.

As the quantity of iron which can be handled at one time in the puddling furnace is limited to about 450 lbs. (that is, the weight of the ball of wrought iron produced), therefore, if plates were required that were heavier than this would make, it was necessary to either "shingle" or hammer two or more of these balls together, or else to pile the blooms made from these balls after the first hammering, which is the usual course. In either case the product was lowered in quality, and when blooms are piled it is practically impossible to prevent laminations in regular products.

However, about this time, as frequently happens, the advent of mild

steel made by the Bessemer process took place, and the extraordinary reduction in cost of plate which was brought about by that process (and later that of the Siemens or open hearth process), together with the superiority of the product and the introduction of hydraulic machinery for riveting, etc., very soon rendered it possible to design boilers with butt joints, double welted and triple riveted, for locomotives which would carry 180 lbs., and for marine practice 120, 140 and 160 lbs. This was accompanied by the introduction of triple and quadruple compounds in marine service. The natural process of refinement in design and manufacture has given us locomotives with boiler pressures of 200 and 225 lbs., and marine engines with boiler pressures almost, and in many cases, quite as great. So long as we had to depend upon wrought iron plates, made one by one, by hand as it were, just so long were we liable to have a different product in each plate, with unknown but radical, and sometimes dangerous, defects. With steel, made in bulk, the difference between one plate and the next was very greatly minimized, and the average result was more certain.

At these pressures of 200 lbs. to 225 lbs. we have practically reached the limiting pressure of the type of boilers which are internally fired and have fire tubes, as the gain in economy decreases rapidly with the increase in pressure. The effect of expansion and contraction, and also of corrosion, which is increased by the temperature of the water, has become so great at the temperatures involved, and the expense of maintenance both in service repairs and in thorough repairs, and the cost in case of failure is so great, that there is apparently no further progress to be made in this direction.

The principal element of the destruction of steam boilers is unequal expansion and contraction, especially if it is confined so as to develop in certain sections, as it is the cause of grooving by corrosion, which is due to each film of rust as soon as formed being worked off by the movement of the plate, and wherever such movement takes place, as, for instance, in lap joints, as well as causing cracks in plates and staybolts. This is the greatest enemy to safety in plate boilers, and shows the necessity of avoiding forms that will distort under pressure or stiff places in the construction, such as placing staybolts too near the edges of flanged sheets, as tube sheets and back sheets of fire boxes; gussets brought too near to stays, etc. There are some places where it is almost impossible to reduce the concentration of movement, as, for instance, in the throat sheet, where cracks are most frequently caused in the ends of



the flange to the boiler barrel. On the other hand, it has been found necessary to increase the stiffness of the barrel itself to withstand the strains of service, and consequently we find the circumferential seams of modern boilers double riveted, even though a single-riveted seam has a more than ample factor of safety as to pressure. This is done to avoid grooving due to strains of service. The stiffness of the mud-ring construction causes grooving in many fire boxes along the inside plate on the water side just above the ring.

Wootten fire boxes, when made in three plates for the crown and sides, undergo corrosion on top of the lap of the longitudinal seams on the water side round the rivet heads, showing the existence of a tendency to buckle the plate

box requires it. It is well known how often stay bolts in deep fire boxes break which are covered by an expansion bracket on the fire-box shell.

The success of the Fox corrugated flue for the Scotch marine type of boiler rendered it possible to dispense with rings or staybolts for the support of the fire flue or box, and to enlarge the grate surface and carry higher pressure without increasing the thickness of the plate exposed to the fire beyond the  $\frac{1}{2}$ -in. limit, but no method has been found whereby the combustion chamber could be rendered self-supporting and avoid the use of staybolts, etc.

Several attempts have been made to use the corrugated flue for locomotive fire boxes, with the same object, but none have been found entirely satis-

#### Consolidation for the B. & O.

The Schenectady works of the American Locomotive Company have recently supplied the Baltimore & Ohio Railroad with some simple consolidation, or 2-8-0 engines, known on the road as the E-27 class. These freight pullers have cylinders 22x30 ins., and driving wheels of 60 ins. diameter, and, with a steam pressure of 200 lbs. per square inch, the calculated tractive effort is about 41,100 lbs.

The valves of this engine are the ordinary slide, but of the Richardson balanced type. They have a travel of 6 ins. and a steam lap of  $1\frac{1}{4}$  ins.; the exhaust lap is  $\frac{1}{2}$  of an inch. The valves are set with  $\frac{1}{16}$  in. lead in full gear, back and forward, and the motion is indirect. The eccentrics are on the main driving axle, and the link is placed forward of the

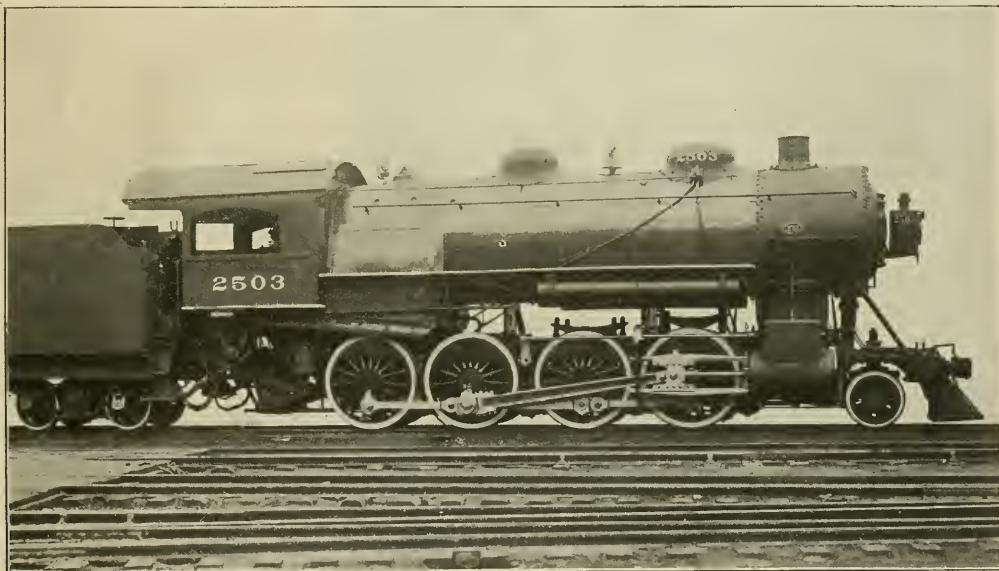

HEAVY SIMPLE CONSOLIDATION FOR THE B. & O.

J. E. Mulfeld, Superintendent of Motive Power.

American Locomotive Company, Builders.

at that point. This brings out the point that the inside fire box, being hotter than the outside, expands more when in service, and it is open to explanation where the excess goes to.

Flue sheets expand when the flues are rolled, and remain permanently larger at each rolling, sometimes attaining as much as  $\frac{3}{8}$  in. in height and width larger than when new, and before being removed. This is the principal cause of flue bridges cracking.

If the outer shell of the fire box is stiffened by being made thicker, it is certain to be accompanied by an increase in the number of broken staybolts, as it will not yield to the bolt when the movement of the inside fire

factory, and have invariably contained the elements of their own eventual failure.

The immense destruction which takes place when a boiler fails under pressure, if it contains a large storage of hot water, has caused designers for many years to endeavor to produce a boiler which, while it may contain a much less quantity of water at any time than any of the various internally fired types, shall be able to evaporate an equal quantity of water per hour at an equal or lower cost for fuel. These designs have all been of what is known as the water tube type, in most of which the water and steam reservoir

(Continued on page 41.)

rocker and has a transmission bar by which the motion of the link block is carried back to the rocker. Brass eccentric straps have been used, and cast steel driving boxes work in brass shoes and wedges. The wheel base of the engine itself is 25 ft. 7 ins., with a rigid wheel base of 16 ft. 8 ins. The wheel base of the engine and tender is 59 ft. 8 $\frac{1}{4}$  ins. The weight of the machine in working order is 208,500 lbs. and the amount carried on the drivers is about 185,000 lbs. Engine and tender together weigh 345,000 lbs. The springs of the two leading drivers are overhung and the main driving wheels are without flanges. The arrangement of piston rods and guides is such that metal packing may be applied when the crank pins are on the forward center.

Piston rings can be applied without disconnecting the piston rod from the cross-head.

The boiler is of simple design and substantial construction with  $56\frac{1}{2}$  sq. ft. of grate area, all in one plane. The tubes are 282 in number and are of  $2\frac{1}{4}$  ins. di-

that the members of the committees could have an opportunity to observe as to the operation, hauling capacity and steaming and riding qualities. A fuller account of the composition of these committees and the objects of their work are to be found in another column. A

Tender Frame—13-in. steel channels and plates. Tank—Style, water bottom; capacity, 7,000 U. S. gallons; fuel capacity, 12 tons.

### Away with Jargon.

A New Jersey inventor has recently come forward with a device for the purpose of indicating to the passengers in a coach, the name of the next station at which the train or trolley car will stop as the case may be. The mechanism consists of a drum in which the names of the stopping points are printed on card or canvas or other suitable material. The words "Next Stop" are permanently displayed on the drum and as the train leaves a station the conductor, brakeman, porter or other transportation officer, turns a small wheel and the name of the next stopping point drops into view. Where this device is used the trainmen do not need to call out the alleged name of the station where the train halts. This indicator will probably fill a long-felt want as far as the passengers are concerned, because the name of the street or town toward which they are traveling will be constantly before them. Many trainmen use the English language in performing this duty, which is a fairly intelligible tongue, but others have invented a strange jargon which the long-suffering traveling public have not become quite familiar with yet, notwithstanding the fact that it has been in use for a number of years. Hail to the beneficent inventor!



STRING OF OLD BELGIAN ENGINES ALONG THE PANAMA CANAL ROUTE.

ameter. They are each 15 ft. 10 ins. long, and, combined, give a heating surface of 2,612.8 sq. ft. The fire box is  $108\frac{3}{8}$  ins. long and  $74\frac{1}{4}$  ins. wide, with  $4\frac{1}{2}$  in. water spaces on all sides. The fire box gives 162.26 sq. ft. of heating surface, and when added to that given by the tubes the total amounts to 2,775.6 sq. ft. The front ring of the boiler is  $74\frac{1}{8}$  ins. outside diameter, and, as the design of the boiler is a straight top, the smoke stack has been made quite short, and the dome and sand box have been flattened to keep within the B. & O. clearance dimensions.

The order upon which this engine was built included five switching locomotives, thirty-five Pacific type, and 210 of the type shown in our illustration. Five engines are to be equipped with the Walschaert valve gear, similar to that used on the Mallet compound which was built for this road some time ago.

The first or sample locomotive was put in service during the month of August, 1905, to give an opportunity for discussion and criticism and to afford a practical demonstration of the merits of this design construction and operation, the result of which would affect the rest of the order. The Motive Power Department appointed three committees to take up the matter. After the arrival of the sample locomotive at Baltimore the members of these committees were given every opportunity to make an examination of the details of the engine. The locomotive was then put under steam, s-

few of the principal dimensions of this engine are as follows:

Boiler—Firebox, type; thickness of crown,  $\frac{3}{8}$  in.; tube,  $\frac{1}{2}$  in.; sides,  $\frac{3}{8}$  in.; back,  $\frac{3}{8}$  in.; water space, front,  $4\frac{1}{2}$  ins.; sides,  $4\frac{1}{2}$  ins.; back,  $4\frac{1}{2}$  ins. Crown staying—Radial. Ex-



OLD FRENCH MACHINERY LYING ALONG THE ROAD OF THE PANAMA CANAL.

haust pipe—Single nozzles,  $5\frac{1}{4}$  ins. and  $5\frac{1}{2}$  ins. Axles—Driving journals, main, 10 ins. x 13 ins.; others,  $9\frac{1}{2}$  ins. x 13 ins.; engine truck journals, diameter 6 ins., length 10 ins.; tender truck journals, diameter  $5\frac{1}{2}$  ins., length 10 ins. Engine Truck—Two-wheel, with 3-point hanger for swing center bearing. Piston rod diameter, 4 ins.; piston packing,  $3\frac{3}{4}$  C. I. snap rings. Smoke Stack—Diameter, 18 ins.

Statisticians tell that there are about 750,000,000 track ties under the railroad track of the North American continent. To keep up the supply calls for clearing 250,000 acres of timber annually. There seems to be a big opening for a substitute for wooden ties, but it is slow in making its appearance.

# General Correspondence.

## Old-Time Railroad Reminiscences.

Editor:

It seems to be a sort of generally accepted supposition on the part of the average railroader that a so-called air brake expert employed by an air brake company has a perennial vacation largely devoted to traveling about the country visiting whatever places his fancy may happen to dictate, and in addition to obtaining the best the market affords, take life generally easy. This, however, has not been the writer's experience, for he has found that moving about the country from pillar to post not infrequently resolves itself into hard work, at times, of not the most pleasant character, and, unlike the drummer who transports his stock in trade in trunks of more or less liberal dimensions, the air brake man carries his commodities in his head, and, instead of showing what he has, must be prepared to verbally produce and unfold whatever his railroad friends may wish to know. In other words, he is expected to be an air brake encyclopedia, ready at any and all times to display and elaborate on his mental wares. It does not follow from this that his railroad friends are always to be found in a receptive mood, for, in the somewhat remote past there were many times—though of late years quite rare—when the air brake man found himself up against railroad officers who did not believe in all the new-fangled apparatus presented to them, when for years the old had proven good enough, and in deference to the opinion of the boss, a similar one, of course, was quite likely to prevail among the rank and file. I wasn't long in the business before it dawned upon me that I must be prepared to combat arguments against the new apparatus, whenever occasion demanded, by comparing and exploiting the new and old devices in a way that would be conclusive in depicting their respective merits, though sometimes it was a matter of considerable time before the opportunity presented itself.

The first real, hard proposition I came in contact with was on a prominent western road, the main line of which was some four hundred miles in length, and on which an alleged air brake failure had occurred, resulting in an accident at a railroad crossing.

I was called upon to visit the road in question and investigate, and it being my first trip in that direction, I had no acquaintance with anyone connected with the company. Reaching headquarters, I

learned the superintendent of motive power was absent for the day, so, naturally, hunted up the master mechanic. After accompanying that gentleman through the shops I began making inquiries about the accident and was informed that an express train had struck a freight covering a right angle crossing and that the accident occurred owing to the brake valve failing to open and discharge air from the train pipe when the engineer endeavored to apply the brakes. Further information elicited the fact that the brake valve was new, having been in service less than three weeks; also that it had been removed from the engine and taken to the master

what the cause of this air brake failure was, but I have found out that you don't know any more about the business than we do."

During this time I had been standing leaning against a high back oak chair, and as he spoke it occurred to me that the master mechanic had coached my auditor, as I had had no conversation with anyone else connected with the road, and having pronounced the brake valve in perfect condition, it was evident my opinion was not proof against the assertion of the engineer and others as well as the fact that the brakes had not stopped the train in time to prevent the collision.

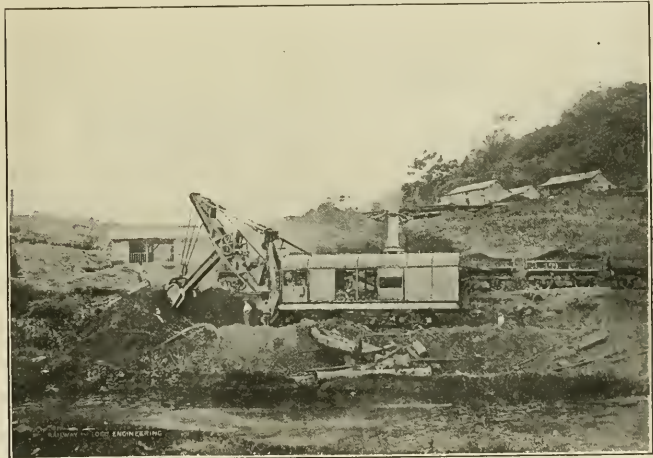

MODERN STEAM SHOVEL ON THE PANAMA CANAL ROUTE.

mechanic's office after the accident.

Upon examining the valve I found it in perfect condition and so stated to the master mechanic, further remarking that the cause of the alleged brake failure must be looked for elsewhere, as the brake valve was all right, and could not have failed to properly operate if moved to the application position. To my assertions the master mechanic made no reply, and as his action indicated a lack of interest, the subject for the time being was dropped.

The following day I was not a little nonplussed when, upon entering the office of the superintendent of motive power and presenting my card that gentleman read it, then looked up, and in a very energetic way remarked: "Well, we sent for a man to come here and tell us

"Well," said I, "it may be possible that I know no more about this affair than you do; but suppose we sit down and discuss the matter like gentlemen and endeavor to ascertain the cause of this apparent brake failure?" Thereupon I was invited to take a seat, and, quickly following, the investigation was on. I was permitted to read the reports of the engine and train crew, but from them little light was afforded other than that the brakes failed to stop the train in time to prevent the accident. By this time it was apparent that radical action must be taken to convince the S. M. P., as well as myself, the cause of the accident, and I made bold to inquire if he had any objection to calling in the engineer and fireman and permit me to question them. To the request he readily

assented, and a few moments later a messenger had been dispatched for them.

The fireman was the first to appear, and following a few preliminaries, in reply to my question. "Did you hear the air blow from the brake valves when the engineer attempted to apply the brakes approaching Central crossing?" he answered, "Yes, the air blew all right, but the brakes didn't set." As there was apparently nothing more to learn from him he was dismissed, and his departure was soon followed by the entrance of the engineer, who, after closing the door, stepped glibly down the office and acknowledged my introduction to him in a most nonchalant way, and with an air plainly indicating his knowledge of what was wanted and faith in his ability to dispose of the question at issue with little or no effort.

It was apparent, too, in the way he pulled up his chair near that of the S. M. P. that the freedom of the office was by no means new to him, and as he seated himself with a look at his superior as much as to say, "Well, what is it?" that gentleman remarked that I would like to question him regarding the accident at Central crossing; then, turning to me, the engineer said: "All right; what do you want to know about this business?"

"Mr. Rawson, I believe you was the engineer pulling the train the night of the accident at Central crossing?"

"Yes, sir; I was!"

"What time did it occur?"

"A little after midnight."

"What sort of a train did you have?"

"Pretty heavy one; nine cars, four of them Pullmans, and a ten wheel engine."

"What was the state of the weather?"

"Well, it was sort of rainy, and very dark, and we were running against a heavy quartering head wind."

"Was you able to make your time?"

"No; we were losing time right along."

"Why were you losing time?"

"Train too heavy and wind too strong."

"I suppose you let her go when you got on your side of the hills?"

"Oh, yes; but I couldn't make up what was lost in the other places."

"What was the grade you were descending just before the accident?"

"Don't know; but it's pretty steep."

The superintendent of motive power here interrupted by calling on his clerk to bring a profile of the road, and which showed the grade to be about 52 ft. to the mile, and one and a quarter miles in length, the crossing being two or three hundreds yards from the foot of the hill.

"Had the brakes been working all right up to this time?"

"Yes, I suppose so, only they set too hard some of the time."

"What caused them to set too hard?"

"That new fangled brake valve (B-11) of yours let the air out too fast and is no good, nohow. I guess."

"What speed were you running down this grade?"

"Oh, we was knocking off sixty or sixty-five miles an hour easy enough."

"Did you apply the brakes after passing the top of the hill?"

"Yes, three or four times."

"Why so many times?"

"Because they set so hard I had to let them right off again."

"Then when you got about the usual distance from the crossing did you apply them again?"

"I tried to, but they didn't take hold."

"What did you do then?"

"About that time I saw the freight on the crossing and I pulled her over; gave her sand and jumped off."

"Did you fall down when you struck the ground?"

"No, but it was about all I could do to keep my feet."

"Mr. Rawson, you are a pretty good jumper if you can jump from an engine going sixty or more miles an hour and in a dark night, without falling."

"Well, I don't suppose we were going more than ten or twelve miles an hour when I jumped."

"If the brakes did not respond when you attempted to apply them what brought the train down from the high speed you say you were going to ten or twelve miles an hour?"

This question elicited no reply, for Mr. Rawson had all at once discovered that his bluff had been called and his arrogant air suddenly changed to a look of surprise and chagrin. Turning to the superintendent of motive power. I remarked that I had no further questions to ask, and as the engineer, with a hectic flush on his face, left the room, I said: "Now I can tell you the cause of that accident. The brakes were all right and quite able to perform their duties had they been properly handled. Mr. Rawson admits that he applied the brakes several times and was obliged to release because they took hold too hard, a condition which resulted from a too liberal discharge of air from the brake valve. At the rate of speed the train was running not more than a minute and a quarter was consumed in descending the grade, and with three or four brake applications and releases in that space of time auxiliary reservoir pressure was depleted with insufficient time to replenish it between applications, and, as a consequence, when the last attempt to apply the brakes was made they responded, but with a greatly reduced braking force owing to the reservoirs containing perhaps forty

or fifty pounds instead of seventy pounds air pressure, and which was insufficient to stop the train in the distance afforded after the application was made."

"Well," said the motive power official, "anybody can see that now, for when the engine struck the box cars two of them opened up like big barn doors and the engine and a part of the train only passed over the crossing before stopping, with no wheels thrown from the track, though the engine was disabled." Reaching for a pile of papers I had not before seen, a report from the station agent was produced and handed me, which stated that a switch engine not equipped with air brakes some twenty-five minutes after the accident, pulled the disabled one out of the way, then returned for the train, and before it could be pulled down to the station the brakes had to be released by bleeding the auxiliary reservoirs.

Future events, however, strongly indicated that the superintendent of motive power was not fully convinced that the B-11 brake valve had not contributed to the accident, for they were promptly removed from all new engines somewhat recently received by the road and, like the valve on the disabled one, replaced with three-way cocks which for years had been the standard.

As is usually the habit of air brake men, I had been a close observer of air brake conditions prevailing on this road and noted a lack of many things most essential to good brake service, but could find no way of getting into the good graces of the mechanical powers to the extent of requesting assistance which I very much desired to give.

For a number of years this state of affairs prevailed, three-way cocks replacing the D-8 and F-6 brake valves, which came on new equipment, the new fangled valves being consigned to the top shelf in the storeroom where dust soon obscured them from view, and even trouble from pump governors was avoided by inserting blind gaskets in the air connection, making possible the increase of main reservoir and train line pressure when in the estimation of the engineer the brakes did not hold good.

In fact, old foggy notions predominated until a change took place and the new management quickly realized the antiquated conditions and took prompt measures to correct them.

I was called upon to participate and did so, spending several weeks on the road, receiving strong support from nearly all the officers, but at the beginning none from the engine men, and how it was managed to bring the latter into line will be told in a future number of RAILWAY AND LOCOMOTIVE ENGINEERING.

S. J. KIDDER.

### To Prevent Railroad Accidents.

BY J. W. READING.

Apropos of my article in November number of RAILWAY AND LOCOMOTIVE ENGINEERING, entitled "Outraging Nature," and before making further comment along same lines, I will quote some statistics as gleaned from the Accident Bulletins, published quarterly by the Interstate Commerce Commission.

After considerable investigation I have come to the conclusion that there is but a very small percentage of the employes on our American railroads who know that there was a law enacted by Congress in 1901 making it obligatory upon the officials of all railway lines, doing an interstate business, to make, under oath, a monthly statement of all accidents which involve loss of life or serious injury to passengers, employes and others, or a property loss of more than \$150.00. This law was approved March 3, 1901, and became operative July 1 of the same year.

Since this statute became a law, the Interstate Commerce Commission have issued every three months an accident bulletin giving data of loss of life and serious injury to persons, the number and kind of accidents and property loss, etc. The accident bulletins are sent to the officials of the operating departments of all railway lines, thereby giving each a chance to know how much grief the other fellow is having, and also to give each a chance to profit at the other fellow's expense. These quarterly reports are certainly "eye openers," and ought to result in great good.

While these reports are the right thing and should be of great value to the intelligent, active, progressive railway official, it is my opinion their distribution is entirely too limited. But few locomotive engine men have ever seen these bulletins, and if they have read, or heard of their publication, the knowledge has escaped their memories. "What is sauce for the goose should be sauce for the gander," and these accident reports should reach "the man behind the gun." Inasmuch as the Commission goes into considerable detail concerning a few of the most prominent accidents, quoting quite extensively from the railway company's report, and making comments of their own which are "right to the point," a class of men most prominently identified in these affairs, ought to profit by this reading matter, which tells of the misfortunes of the other fellow.

It would, possibly, be out of the question for the Commission to distribute to all concerned copies of their quarterly reports, but a great many of the rank and file most prominently identified might be reached if a copy was mailed to each division of the B. of L. E. and O. R. C. A number of our most prom-

inent, progressive railway companies have fitted up for their employes rooms for reading purposes, etc., and if these accident bulletins are not on the reading tables of these pleasant quarters, they should be there. Officers who are the most closely identified with the engine and train management should not only see that the copies, as fast as issued, were placed upon the reading tables, but they should bulletin a notice to that effect, and kindly ask the favor that each and every one concerned should read it. The Commission in their reports do not make public the name of road, time, or place of accident, and no bad results could possibly come from a larger distribution of the bulletins, while on the other hand if the seriousness of these affairs were brought nearer home to the parties most concerned, they certainly should, or ought to be, object lessons of untold value. Person-

Accident Bulletin No. 10, just out, completes the fourth year, and I have compiled a few items which may be of interest. During the four years ending June 30 last, the Commission's report shows a total of 42,193 accidents, the property loss amounts to the enormous sum of \$36,281,829. I have no data as to the amount paid for personal injuries and loss of life, which would undoubtedly add millions to the figures already given.

The greatest number of accidents reported in any one of the 16 quarterly bulletins, so far published, is given in No. 15, comprising the months of January, February and March of this (1905) year, the total number being 3,108. The greatest property loss for one quarter is reported in Bulletin No. 9, which comprises the months of July, August and September, 1903, the amount being \$2,584,348.

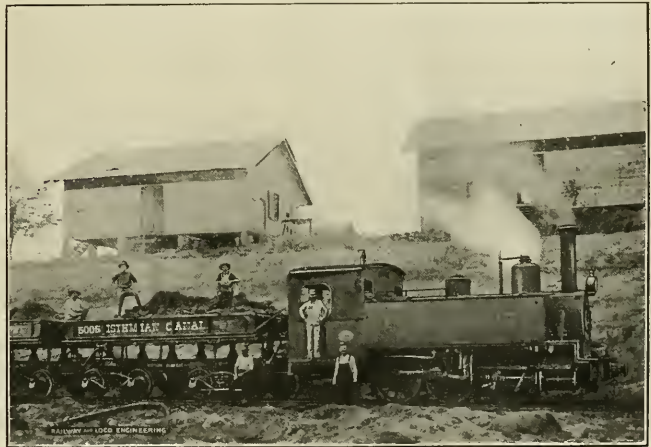

OLD DUMP CAR AND OLD BELGIAN ENGINE ON THE PANAMA CANAL ROUTE.

ally, I would like to see the Commission go farther into the details of the accidents which involve life and serious injuries to persons, and great property damage. It should be shown in each prominent case how much experience the parties at fault have had, the number of hours on duty; they might go further, and investigate conditions that confront these employes, not only on but off duty. Might note whether company in distress had ever made a move to give their train and engine men comfortable quarters and tried to establish a kindly supervision over them while off duty. This "eye opening" business is the proper thing, but as yet the opening has not been enough to let either the management of railroads, the employes of the same or even of the public to see a great way beyond the end of their respective noses.

Out of 477 prominent accidents occurring during the four years, 279 are charged to the employes in the engine, train and yard service; 73 to the dispatchers, operators, signal towermen and others in like service; 125 to track men, train wreckers, washouts, fires and other causes unknown; 16 engineers are reported as being asleep, and 2 charged with being intoxicated; 477 is a very small proportion of the total number of accidents given, and it would be interesting and educational to know if the same ratio of causes was in evidence all the way through. During the first quarter ending September 30, 1901, the property damage was \$1,824,224. The damage reported during the quarter ending with June 30 this year is \$2,410,671, an increase in the last over the first quarter of \$568,447. The first quarter shows a total of 11,212 persons killed

and injured. The last quarter shows a total 14,669, an increase in the number of persons killed and injured amounting to 3,457. In the first quarter the total number of passengers killed was 240, in the last quarter 262, an increase of 22. The total number of passengers injured in first quarter was 2,622, in last quarter 2,764, an increase of 52. The increase in the number of deaths of employees and passengers who were killed while jumping on or off of moving trains in last quarter over first is 161. The increase in injuries, of same class last noted, is 3,296. If complete statistics up to June 30 of the present year were at hand so that comparisons might be made of the number of passengers carried and number of men employed in first and last quarters might be shown, we could give more interesting data as to the good we are deriving from improved conditions, such as the block system, vertical plane couplers, air brakes and other safety devices.

I am just in receipt of a letter from a brother engineer who lives far away in a southern State, and as his remarks are quite pertinent to the subject in question I have taken the liberty to quote some of the things he has mentioned:

"In your article on 'Outraging Nature' you need to emphasize one point which you omit, that is the need of limiting the mileage that shall be required of an engine man . . . No man can make from 4,500 to 5,500 miles a month on a 12½ mile per hour schedule and secure rest enough, even though he sleep all the time off duty. The regular engine, and regular run, and some other things that might be mentioned are used as a club to force engine men to make mileage far in excess of what they should. . . . My position is, and has long been, that the average train man needs, not only to be protected from himself and his fellow employee, but also from the desire of his superior officer to make a showing for his division. . . . In the 'Badham wreck,' in S. C., it was shown to the State Railroad Commission that the club was used to move trains when the crew had been on duty 40 hours. . . . We need regulations that are operative in both directions. Personally, I am glad your letter is noticed editorially, and I hope for better things eventually."

In quoting from this letter of a brother engineer I have tried to show a few points which will have more or less bearing on future articles I am in hopes to contribute to the columns of RAILWAY AND LOCOMOTIVE ENGINEERING, providing, of course, that the subject discussed is of interest enough to meet the approbation of the management of said magazine.

The distressing accidents on our railroads continue; improved conditions along some lines are outweighed by added burdens in other lines, and inasmuch as every accident has its cause it is the duty of every one, whether in or out of railway service, to dig at the root of the tree of disaster. If I could save one individual life by anything I could write, say, or suggest, I would feel that I was possibly of some little use on earth. 'Tis said that "the pen is mightier than the sword;" if there is any truth in the quotation as regards the dispute of nations, it ought to be of considerable value in civil pursuits.

It seems too bad that more engine and train men do not take up their pens in defense of their calling and the charges made against labor. The boys who must face the conditions and go down to their death, at times get too little credit for sacrifices made. Justice is often blindfolded; many verdicts would be changed if all truths were known. I agree with the brother engineer from whom I have quoted that "we need regulations that will work both ways."

#### Professor Sweet Explains Peculiar Wear of Eccentrics.

On page 554, in answer to question from J. S., of Pottsville, it seems to me you are dead wrong when you say, "It is evident that if there is no soft part in the metal the part farthest from the center will wear faster on account of its higher velocity of travel in the strap."

One part of the eccentric does not travel any faster in the strap than any other part. An easy way to render this clear to the mind is to reverse the action; that is to say, assume that the eccentric strap to be held fast and the eccentric revolved by the shaft worked as a crank. From this it will be seen at once that all parts of the eccentric moves in the strap uniformly; but a second thought with most mechanics is enough without this illustration. The true explanation of why the small part (that is, the part nearest the shaft) of the eccentric wears the fastest is because it has the most work to do, for it is that part that has to reverse the direction of the valve, and it takes more to reverse and start the valve in the opposite direction than to continue it.

It is always the same part of the eccentric that does the reversing in both directions. As a fan always drives the air by its front face, so, too, does an eccentric always drive from its front half except in a reversing engine.

JOHN E. SWEET.

#### Front-End Attachment.

Editor:

I have an idea in mind for some time of a device to make locomotives on fast

or continuous runs steam more freely, and, consequently, result in saving fuel. I would place a couple of air scoops or funnels on the sides of the smoke arch, connected with pipes terminating in a tip or nozzle, thus forcing an air blast up through stack when running. This is probably an absurd or impracticable expedient, but would like very much to have your opinion—condemnatory or otherwise. I have talked with some mechanical men about it, and none exactly condemn it, but simply said they did not know of what value it might be, and that perhaps a trial would be the only way to test it. Engines are fired up by means of an air blast in many instances, and it therefore occurred to me that an air blast, while running, might also be beneficial. I thought possibly that the in-

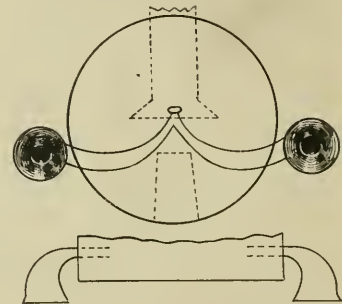

PROPOSED FRONT END ATTACHMENT.

creased vacuum obtained by this blast might be the means of doing away with the exhaust pipe nozzle or tip altogether, thus relieving back pressure and making engine more economical. While standing or in starting the train, the blower would, of course, have to be used until sufficient speed had been attained to create the proper blast. I would be glad to hear what your readers think of this device.

OLAF OLSON.

*South Kaukauna, Wis.*

The Westinghouse Electric & Mfg. Company are doing a large business in equipping mines with electric locomotives, to replace the older forms of haulage, whether animal or mechanical. Electric mine haulage, considered from either the points of efficiency or economy, has so many advantages, as compared to the older practice, that the time is not far distant when any other method of mine haulage will be the exception.

"Judgment is safer than emotion. It does not create half the enthusiasm, but it stays longer. Strength without wisdom is like the hurricane speeding unguided across the plain, and piling in its awful havoc alike the empty hut and lofty temple."

### Locomotive Blow-off Valve.

A particular form of locomotive blow-off valve may be seen by anyone who visits the Homestead Valve Manufacturing Company, of Pittsburgh, Pa., or by those who care to examine the engines equipped with them on many of our leading railways. The Homestead locking cock, for so it is called, is similar in principle to the straightway valve which has been on the market for some time and which is made by the same concern.

The idea embodied in the original design is to have the plug held tightly when in a certain position, but loose and free during the time it is turned from open to shut or from shut to open. This is accomplished by introducing on top of the plug a flat cam which is prevented from turning when the plug is moved. The cam is beveled, and it lies loosely in a small chamber above the plug when the valve is open. Under this cam is another similarly beveled cam which moves with the plug. These cams, when the valve is open, are so placed that the thick side of one lies on the thin side of the other.

When the plug is rotated from open to shut, the thick portion of the lower and revolving cam approaches the thick portion of the upper and stationary one. When the valve is completely shut the pressure of the cams with their "thicks" together keeps it tightly on its seat and further movement in the same direction is impossible. When a movement from shut to open takes place the cams slide easily upon their beveled surfaces and at once reduce the pressure on the plug.

The Homestead locking cock is but a modification of the same idea. In it, both the open and closed positions are locked or, in other words, the valve is held firmly to its seat in either position by beveled cams which are made to jamb when the valve is full open or full shut. The locking of the valve thus prevents leaking while a free easy turning motion can instantly be had. If you are interested, write to the makers for a catalogue. The idea is interesting and is cleverly worked out.

Only one couple in over 11,000 live to celebrate their diamond wedding.

### Locomotive Porridge.

The Washington Avenue roundhouse of the Big Four, at Indianapolis, has a novel way of lighting up engines. The shop was originally piped for a system using crude oil for starting fires, and a tank for holding the oil was sunk in the ground outside the building. When the crude oil lighter was in vogue there were about 30 pints used per engine for each fire.

At the present time, although the crude oil is still used, it is mixed with shavings and chips which come from the planing mill. An iron receptacle has been placed near the sunken tank and in this the mixture is made. The receptacle is something like a coal bucket and is

tiously and economically; the maintenance of pipes and the supply of compressed air is dispensed with, and the engines having once used this form of breakfast food prefer it to all others.

### Practical Puzzle Problem.

Here are the conditions for a first-rate puzzle problem. A man has a steel stack at his factory 200 ft. high. It needs painting. There is no ladder to the top, and no apparent means of getting there except by balloon. This was the problem presented to a western mill owner, says the *American Miller*, and he solved it in the following ingenious way: A rude parachute, slight-

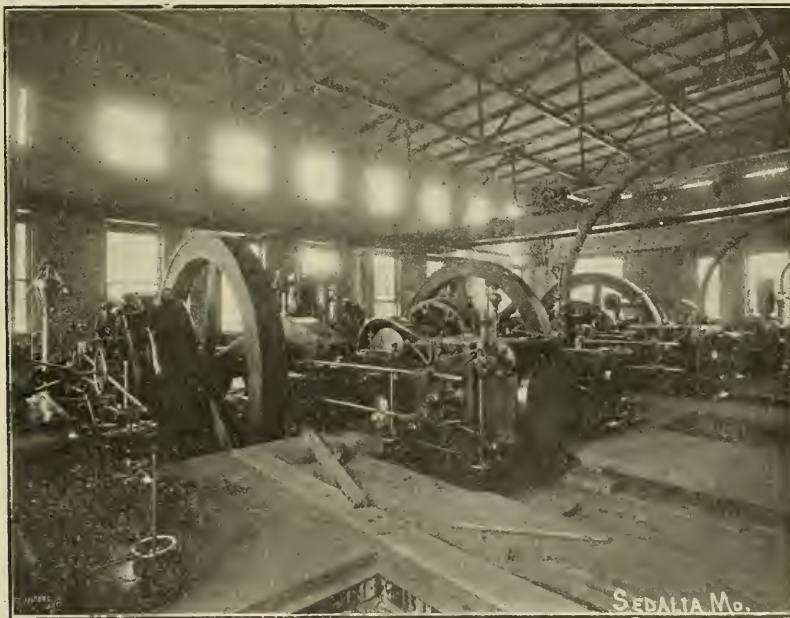

INTERIOR OF POWER HOUSE, MISSOURI PACIFIC SHOPS AT SEDALIA, MO.  
(Courtesy of the *New Southwest*.)

about 48 ins. in diameter and about 4 ft. high.

A sufficient amount of shavings and chips is put in the receptacle and a few buckets of crude oil is then poured in, and the whole mixed up into a sort of locomotive porridge, which is fed to the engines as occasion requires. An ordinary 4-4-0 engine can get along with a bucket of porridge, but a 4-4-2 and the heavier engines need two buckets to sustain them.

The use of this mixture has several advantages. The quantity of crude oil used for each fire is about 20 pints, instead of 30 as formerly. The shavings, chips, etc., have to be handled in any case, and this disposes of them expedi-

ly smaller than the internal diameter of the stack, was constructed; to this a pail filled with light fishing line was attached, and then the parachute was shoved up in the stack until it passed the draft opening from the boilers. The hot gases caught it and rushed the whole contrivance up and out of the top of the stack in a jiffy, the fishing line in the meantime paying out as the pail rose, so that one end remained at the bottom of the chimney and the other fell to the ground outside with the pail. By means of this line a heavier rope, with a hook to catch over the rim of the top, was sent up, and with this the painter was able to complete the job.

# Railway and Locomotive Engineering

A Practical Journal of Railway Motive Power and Rolling Stock.

Published Monthly by

**ANGUS SINCLAIR CO.,**  
136 Liberty Street, New York.

Telephone, 984 Cortlandt.  
Cable address, "Loceng," N. Y.  
Glasgow "Locauto."

**Business Department:**

**ANGUS SINCLAIR, President.**  
**FRED M. NELLIS, Vice-President.**  
**JAMES R. PATERSON, Sec'y and Treas.**

**Editorial Department:**

**ANGUS SINCLAIR, Editor.]**  
**GEO. S. HODGINS,**  
**JAMES KENNEDY,** } Associate Editors.  
**J. F. KELLY,**

**Advertising Department:**

**Eastern Representative, S. I. CARPENTER,** 170 Sumner St., Boston, Mass.

**British Representative:**

**THE LOCOMOTIVE PUBLISHING CO., Ltd.,** Amen Corner, Paternoster Row, London, E. C.

**Glasgow Representative:**

**A. F. SINCLAIR,** 15 Manor Road, Bellahouston, Glasgow.

**SUBSCRIPTION PRICE.**

\$2.00 per year, \$1.00 for six months, postage paid in the United States, Canada and Mexico. For other parts of the world, \$2.50 or ten shillings. Single copies, 20 cents. Remit by Express Money Order, Draft, Post Office Order or Registered Letter. Mailing address can be changed as often as necessary—always give old and new address, and if you subscribed in a club, state who got it up. Please give prompt notice when your paper fails to reach you properly.

Entered at Post Office, New York, as Second-class mail matter.

Copyright by Angus Sinclair Co., 1905.

For Sale by Newsdealers Everywhere.

**Notice to Subscribers.**

We have recently completed the engraving of our transparent educational chart No. 8, which consists of half of a day passenger car and half of a sleeping car with all the parts numbered and named. This chart will be given to old and new subscribers for the year 1906. If the subscriber prefers to receive one of the locomotive charts instead of the car, we are perfectly willing to give chart No. 2 (the American locomotive 4-4-0) or chart No. 7 (the Atlantic type locomotive, 4-4-2).

**Tendencies in Locomotive Building.**

At first sight there does not appear to be any very marked tendency exhibited in locomotive building, viewed as a whole, in the United States during the year 1905. There has been everywhere such a persistent demand for motive power on all our railroads, and the date of delivery has had such a prominent place on the list of specifications put before builders that few railroads have had time or inclination to insist upon special features. This may or may not have been a satisfactory state of affairs according to the viewpoint taken, but it has had the effect of heading off any tendency toward fad chasing.

On a closer view of the subject it seems fair to say that the superheater as a locomotive device has been experimented with seriously, and efforts have been made to find out from actual service tests exactly what it will do and to what extent the economy which has been expected from its use can be made to appear on the monthly performance sheet.

It may be said concerning the piston valve that it has held its own or, rather, that it has made something of an advance. Its defects have been recognized, but its advantages in the matter of maintenance as well as its comparatively low first cost have induced quite a number of roads to continue its use or to adopt it.

The balanced compound has certainly forged ahead in the estimation of motive power men. The once great obstacle in the way of its success, the cranked axle, has been successfully overcome, and the advantages of the compound principle when allied to the smooth running machine, in which severe working stresses are avoided, has caused this type to steadily increase. In locomotive building as in the world of nature, the law of the survival of the fittest must operate not only to preserve that which is in itself worthy, but it tends to bring into being forms which are best suited to meet the changing conditions incident to any substantial progress.

Perhaps the most marked feature which the work of the past year presents is the desire to improve the valve gear of modern high speed locomotives. This desire for something with which to replace the familiar indirect valve motion first manifested itself some years ago by the introduction of direct gear. The change thus made was not for the purpose of securing more theoretically correct steam distribution, nor did the change even incidentally produce that result. The desire sprung from an effort to make the working parts somewhat lighter and to keep them more in their proper line of movement from eccentric to valve rod.

For both these purposes the Walschaert valve gear came readily to the hand of the designer and so satisfactory have been the results achieved that the year just closed has seen its growing appreciation by both designer and builder. In the matter of accessibility the Walschaert gear has an unquestioned advantage. Under heavy consolidation engines there is small room for the necessary cumbersome valve gear required, and except when the engine is standing on a pit there is little chance to get at it. For purposes of inspection, lubrication and repairs the newer form of gear is oftentimes preferable to the older.

In this connection it may be stated

that a large saving of dead weight in valve gear was recently brought about on a heavy Prairie type engine, built by the American Locomotive Company for the Lake Shore & Michigan Southern Railway. The earlier engines of this class were fitted with Stephenson link motion of the direct type, and the total weights of the working parts, exclusive of the valve itself, was 4685 lbs. The introduction of Walschaert gear on more recent examples of the same type cut down this weight to 2,940 lbs.; thus a saving of 1,745 lbs. was effected.

When one considers that the gradual increase of locomotive tonnage, higher pressures and faster speeds which have steadily been going on have necessitated the use of heavier individual working parts, one begins to realize the importance which must attach to any form of detail construction which will secure efficiency equal to the old standard, but with a minimum of dead weight and a consequent reduction of wear and tear.

Valve gear does not usually move at an excessive velocity nor does it travel over much distance, but it nevertheless has to be moved forward, stopped, and its motion reversed for every revolution of the driving wheels. It is easy to see that valve gear weighing more than two tons must necessarily consume a great deal of power to start, move and stop it, and at the same time it introduces more or less lost motion where least desired, and also renders the maintenance charge correspondingly high.

A very significant fact, brought to light by the observation of Mr. H. F. Ball, superintendent of motive power on the Lake Shore, was that a fast passenger engine after making 32,000 miles developed lost motion amounting to  $\frac{1}{8}$  of an inch in the old-fashioned direct valve gear, while a similar machine supplied with Walschaert gear made a record of 39,000 miles and showed only  $\frac{1}{16}$  of an inch lost motion.

The advantages of a form of valve gear which lends itself to the reduction of dead weight almost equal to half the total amount involved, and in which accessibility is a salient characteristic, are too obvious to need special comment. Judging the future by the past, it is safe to predict that Walschaert valve gear will eventually become a recognized feature in American locomotive practice.

**Expenditure of Power.**

There is a piece of railroad main line in the Rocky mountains which is a little less than eight miles long, but which is always of unusual interest to the traveler, owing to the fact that while he is going along upon the ground, so to speak, he is being lifted vertically 1,143 ft. The piece of track to which we refer is situated between Field and Hector on the



Canadian Pacific Railway and the grade which on the road is generally called the "big hill," is climbed by east bound trains when going along the lower portion of Mount Stephen through the Kicking Horse pass.

There is about 7 miles of grade, and the average rise is a little more than 163 ft. to the mile, and this is something over a three per cent. grade. The grade, however, is not uniform, but ranges from a rise of 39.2 ft. to the mile to a raise of 237.6 ft. to the mile. These figures indicate a change of grade from seven-tenths of one per cent. up to four and a half per cent. There is, roughly speaking, three miles of 2.2 per cent. and 5 miles of  $4\frac{1}{2}$  per cent. grade on the Field hill.

On the occasion when a representative of RAILWAY AND LOCOMOTIVE ENGINEERING traveled over this piece of road, the Imperial Limited, as it is called, was made up of eleven coaches weighing in all 981,580 lbs., and there were four locomotives used to work the train, as our English friends would say. These engines were disposed as follows: One Richmond compound, 2-8-0 class, at the front end, after which came five coaches; two simple consolidations coupled together, were placed in the middle of the train, and six coaches and another simple 2-8-0 engine brought up the rear. The compound weighed about 154,250 lbs. and each of the three simple engines weighed 185,000 lbs.

These engines carried 200 lbs. steam pressure and when working full stroke developed a combined tractive effort of about 139,918 lbs. In other words, that is the weight which these four locomotives could pull up out of a well, if to the back coupler of the last engine a cable was attached which passed over a frictionless pulley. These four engines together could about lift an ordinary 70 ton engine. Another interesting fact brought out by this view of a hard hill climb was the fact that the combined weight on the drivers of all the engines amounted to 629,250 lbs., and with the combined starting effort given above, the ratio of adhesive weight to tractive power is 4.49, or, in round numbers, 4 $\frac{1}{2}$ . That means that these engines could pull something less than a quarter of the weight on their driving wheels. They are, therefore, pretty sure footed mountain climbers as they are, and when working on the hill notched up at all, the tendency to slip is still further reduced while the margin of power maintained is sufficiently large for the work.

There are three safety switches on the four and a half per cent. grade. These are switches which turn out of the descending main line and are led up a steep bank to one side, which is sloped in the opposite direction to the main grade. The switches are tended by men sta-

tioned on the ground all the time, and are normally kept open except when the main line is in use. A train descending the grade, if under full control, whistles for one of these switches which is then set for the main line and the train proceeds on down; the switch being turned for the siding again immediately it has passed. When climbing the grade the switches are set for the main line on information given by the lower to the higher switchman over a telephone line which runs from Field to Hector. The grade is steep, with curves of from 3 to 11 degrees radius, but traffic is worked with no more delays than occur on other portions of the road, and with safety always as the prominent feature.

#### Cost of Railways.

In looking over the reports of the expenses of building and maintaining railways it is surprising how much the cost of ties amounts to, and while various devices for treating timbers with coal-tar, creosote, zinc and other preservatives have tended to lessen the amount of this item, it still remains an important factor of cost. A general average of expense of maintenance of way, places the cost of labor at about 50 per cent., roadbed 25 per cent., ties 15 per cent., rails 7 per cent., and ballast 3 per cent. It will thus be seen that ties cost more than twice as much as rails, and in recent years the leading railway companies have given much attention to this subject. In the North and East it has become a serious factor, as the forest lands are moving further and further away, Virginia white oak being, perhaps, the nearest, and Georgia and Alabama pine being next. Neither of these are as durable as locust or chestnut, but the forests of New York and Pennsylvania have been denuded, and it will take another couple of decades before the extensive planting of timber which has been introduced by the Pennsylvania Railroad Company will have grown sufficiently to be available for the rapidly increasing demands of that road alone, which at present requires about 3,500,000 ties a year, at a cost of about 75 cents each. Other railways require as much in proportion, but every road is not possessed of the advantages enjoyed by the Pennsylvania in owning vast tracts of forest land where the company is now planting about 400,000 trees a year, at a cost of about 8 cents for each tree, about 400 trees being the average for an acre.

The average life of a tie is about ten years, and it is a matter of surprise that British railways manage to get about twenty years' service out of their ties. Of course, American traffic is much heavier, but not proportionately with the

short-lived tie. There is a more careful and effective method in saturating the timber with creosote in Britain which prevents the wood from rotting so readily. They also put a soft felt pad between the tie and the plate which holds it to the rail so as to protect the tie from being hammered between the rail and the ballast. The metallic chair is also larger, to keep the rail free from the ties. The general cost of the ties is about the same in both countries, but the British manage to get nearly twice the service out of the ties as is done by the leading American railway companies. The British have learned much from us in railway matters, but there are a few things that we might learn from them.

#### "The Joule" Ought to Be "The Thompson."

A monument was recently erected near Manchester, England, to honor Dr. James Prescott Joule, the noted scientist, whose principal work was establishing the mechanical equivalent of heat, which he made out to be 772 foot pounds. Since Joule's time physicists with very accurate instruments have demonstrated that heat requires for its production and produces by its disappearance mechanical energy in the proportion of 778.3 foot pounds for each unit of heat or one pound of water raised one degree Fahr. at its greatest density. So Joule was mistaken 63 foot pounds in his experiments.

The exact experiments that eventually in demonstrating the relation between heat and mechanical work were begun by Benjamin Thompson, an American engineer in the employ of the Bavarian Government. Before that time it was supposed that heat was a tangible substance that caused changes of temperature according to the quantity present.

In watching the boring of cannon Thompson came to believe that there was a close relationship between the heat generated by the boring cutter and the mechanical energy expended. He proceeded to make carefully conducted experiments with the best heat-measuring apparatus he could devise. In 1798 he presented a paper to the Royal Society of Great Britain, describing his experiments, in which he calculated the mechanical equivalent of heat to be 783.8 foot pounds.

The scientific world receded very slowly and reluctantly from the idea that heat was a material fluid; but truth prevailed by slow degrees, and other scientific investigators took up the work that Thompson had begun. Some forty years after Thompson's paper was presented to the Royal Society, James Prescott Joule began a very thorough and tediously conducted

series of experiments on the relation between heat and work. After eight or ten years of research and experimenting he concluded that the real mechanical equivalent of heat was 772 foot pounds, which was accepted by the scientific and engineering world as correct. It was not correct, however, as other scientists have demonstrated beyond peradventure that the real equivalent is 778.3 foot pounds. Yet the leaders of the scientific world give Joule the credit of establishing the mechanical equivalent of heat, and call the amended equivalent a "joule," although the owner of the name did not come so near the truth as Thompson did, by about one foot pound.

It is a curious way of according honor for scientific discoveries. Thompson was not only the discoverer of the mechanical equivalent of heat, he was the first apostle to discover and proclaim what heat is; yet his name is ignored for that of one who was a late worker in this field of research. In according the honor, the leaders of science have not considered which person did most for the world, but which of the two men had the greater number of friends to glorify his name.

#### The Fatal Horse.

Railroads are receiving the character of being dangerous, owing to the increasing number of people killed and maimed in train accidents, and the appalling figures concerning these disasters make many people feel thankful that they have returned safe and sound from every journey of any length they undertake. The automobile is coming to be regarded as an undesirable second to railroads in killing and wounding people, the riders in such vehicles sharing in about equal degree with pedestrians dangers to life and limb. This is the impression believed by the reading public, based principally upon the conspicuous place given by the daily papers to accidents caused by railroads and automobiles. Yet it is not true, for the most dangerous power of locomotion is the horse.

"The chief cause of horse accidents," says the Philadelphia *Saturday Evening Post*, lies in the fact that this noble animal—beautiful, docile, affectionate; man's faithful friend and patient servant—is born a fool, and never gets over it. Its intelligence is overestimated.

"One of the accident insurance companies recently published a statement, based upon its own returns, which showed that out of one hundred average accidents caused by the horse, the railroad, the automobile and the bicycle, eighty-two are attributable to the equine brute, nine to the railroad, five

to the motor car, and four to the "silent wheel." One reason why physicians are rated as bad risks is that they use horses so much for driving about—an idea the justice of which is indicated by the fact that, out of 972 accidents to doctors recorded by another concern, 267, or considerably more than one-fourth, were due to horses.

"With average luck, if you are a man, you are due to be disabled more or less seriously by a horse once in a lifetime of sixty years. If it were possible for you to live long enough to have one hundred such accidents, you might reasonably expect to be bitten on three occasions—a horse bite is no joke, by the way—to be kicked nineteen times, to be knocked down twelve times, to be stepped on eight times, to fall off while riding three times, to be hurt while getting into or out of vehicles eight times, and to suffer injury in runaways forty-two times. The balance of the mischances would be miscellaneous.

"The principal destruction of human life by tigers is in India, where, according to the official reports of the British Government, those formidable animals kill about one thousand persons annually. Data on the subject for the rest of the world are not obtainable, but it is quite certain that all the tigers on the earth do not destroy half as many human beings in a twelvemonth as are slain in the same length of time by horses in the United States alone. Twenty thousand people are fatally bitten by venomous snakes in India during an average year, but all the cobras, rattlesnakes and other serpents in the world do not cause anything like half as many deaths as are occasioned by horses."

#### Boiler Explosions.

The recent explosion of a boiler on a government gunboat has created a discussion in the press in regard to steam engineering that seems endless. A notion seems to be gaining ground that all boilers except those owned by the government are well kept and properly inspected. This is a gross error. Last month a case came to our attention of a twenty-three year old boiler blowing up in the hands of a farmer, and at the coroner's inquest the facts came out that the boiler, when built, had the safety valves set at 60 lbs. pressure. During the period of service the boiler had changed hands six times, some of the farmers having the pressure raised, evidently presuming that the boiler must be getting stronger with age. The harvest this year was extra heavy, and the threshing machine was too much for the overworked boiler although raised to 80 lbs. An inspiration came to the farmer and he tied the kitchen poker to the safety valve lever. This was the

straw that broke the camel's back. The crown sheet came down with a crash, and the boiler threw a somersault killing one man and injuring three others. It does not require to be much of a prophet to say that there are other boilers in similar conditions whose finish will be marked by luridly spectacular accompaniments.

It need not hardly be pointed out to the readers of RAILWAY AND LOCOMOTIVE ENGINEERING that fifteen years' service is a reasonable length of time for a boiler to be in operation, and if by reason of great strength and the addition of a new fire box and flue sheet and flues its days may be prolonged for over twenty years, in any event the working pressure should be considerably lessened. Experiments have shown that the best metal used in boilers deteriorates about three per cent. per annum. We rarely hear of a new boiler bursting. It is the old, whited sepulchres that burst into pieces, and it is high time that our State legislatures should frame some sensible laws regulating the inspection and age limit of the boilers of steam engines.

#### Oil-Burning Locomotives.

The use of oil as fuel in locomotives, although by no means a recent innovation, has during the year become of much more general use, especially in the Southwestern States, that reliable data concerning its use can now much more readily be obtained than formerly. In the matter of cost of fuel the oil is much cheaper than coal, the work of handling is much less laborious, the duties of firemen approaching nearer to that of engineer. A short term of practice makes the firemen very expert in the use of the various valves adjusting the feed and distribution as well as the variable pressure at which the volatile fuel must be injected into the fire box.

As with all other kinds of fuel, however, boiler repairs constitute the most important item in the running work. Leaking tubes continue in a more marked degree to be the chief cause of engine failures. With the oil burners the flues do not last as long as with coal burners, owing to the intenser heat being more rapidly developed. The turning off and on of the fuel supply when stopping and starting, with the consequent sudden variations in temperature in the fire box, also accelerates the tendency to induce a constantly increasing leakage in the fire box end of the flues. Tubes with welded steel ends are in some cases replacing the older methods, thereby obviating the use of copper ferrules which are more readily affected by rapid changes in temperature. Smaller holes in the tube sheet are also being experimented with in some new engines, thereby extending the area of the heating sur-

face and lessening the liability to small fractures.

There has also arisen differences of opinion as to the methods of working a locomotive to obtain the best results with the new fuel. Whether should the throttle lever be fully opened and the reverse lever adjusted to a short stroke of the valve, or should the throttle lever be partially opened with a longer valve travel? This question is not new, the conviction being that at high rates of speed and running lightly the lever should be "hooked up," giving the valve as short a stroke as will admit sufficient steam to maintain the high velocity. The reports from many of the engineers in charge of oil burners is that engines running with throttle valves partially open and a fuller opening of slide valves are more economical in fuel, show less

fractures from passing laws that would adjust the "fellow servant" iniquity are just turning themselves loose to help the Panama Canal laborer to do as little work as possible. Certain transportation interests have striven for years to prevent the cutting of the Panama Canal, and there is cause for grave suspicion that the friends in Congress of the Panama laborer are merely the traitors who hang back and fire on reputed friends in the rear.

#### Disloyalty.

Two railroad supply men were talking about a particularly able superintendent of a factory who had changed to another concern, and one of the visitors was full of regret at the loss sustained by this superintendent leaving, and feared that the business would suffer from the

#### Latest Canadian Pacific 4-6-0.

One of the first products of the Angus Shops, of the Canadian Pacific Railway, at Montreal, and something which is new on that road, is the type of engine which we here illustrate. This engine is a ten-wheeler and is intended for passenger and freight service; five of them have been built.

They are simple engines, supplied with superheaters. The cylinders are 21x28 ins., and the driving wheels are 63 ins. in diameter. This, with a boiler pressure of 200 lbs., gives a calculated tractive effort of about 33,320 lbs. The weight on the drivers is 141,000 lbs., and this gives a ratio of tractive power to adhesive weight as 1 is to 4.2.

The total weight of this 2-6-0 machine is 192,000 lbs. The valves are of the piston type and are driven by direct mo-



CANADIAN PACIFIC TEN WHEELER FREIGHT AND PASSENGER ENGINE.

H. H. Vaughan, Superintendent of Motive Power.

Canadian Pacific Railway, Builders, Angus Shops, Montreal.

work on the motion and show less condensation by carrying particles of water into the steam chests.

#### Secret Opponents of the Canal.

Some of the Congress people in the national capital are laboring loudly with their mouths in behalf of the poor laborers on the Panama Canal, and are trying to have all sorts of laws passed to reduce the work performed by the laborers aforesaid. A curious thing about this zeal for the interests of the Panama laborer is that the Congressmen working to make his work as easy as possible are always on the other side when measures are brought up to help labor interests in the United States. Some of the men who have labored successfully to prevent state legis-

lation, the transmission bar, which is straight, running from the link block over the leading driver axle to a rocker with hanging arms. The connection to the valve rod is made with a sort of open crosshead, which is standard on the C. P. R. The sand box is placed well forward and has two sand pipes running from it on each side; one of these feeds sand on the rail immediately in front of the leading driver and the other conveys sand to the front of the main driver. The dome is situated in the rear portion of the central cab, and there is an opening in the roof of this cab which can be lifted out of the way when it is necessary to take the dome cover off. The engineer rides in the front portion of the cab, and has an unobstructed view of the road ahead. As this engine uses

change. The other thought the loss was by no means serious. "Mr. Blank," said he, "was the best shop manager I ever knew when he was attending strictly to his business; but he was too much given to talking about the shortcomings of the financial officers and finding fault with others. Disloyalty was natural to his disposition. I do not care what ability a superintendent may have, a spirit of disloyalty will spoil his usefulness." So say all of us. We have no use for a disloyal person, no matter what may be the position occupied. A disloyal office boy is too much for one establishment.

The authorities of the city of Milan, Italy, are arranging for a great International Exposition to celebrate the completion of the Simplon Tunnel.

superheated steam there is a small oil pump on each side placed over the steam chests and this insures a positive oil feed to valves and cylinders.

The boiler is a straight top one and has a Wootten fire box. The grate area is 76 sq. ft., and the grates are arranged for the burning of fine anthracite coal or culm. The box itself is 110 ins. long by 100 ins. wide, and the crown sheet is radially stayed. The boiler shell consists of three sheets, the smallest being 5 ft. 11 $\frac{3}{4}$  ins. outside diameter. The heating surface is in all 2,313 sq. ft. The tubes are 244 in number, 2 ins. in diameter, 15 ft. 7 $\frac{1}{8}$  ins. long. There are 22 tubes 5 ins. in diameter, which are used in connection with the superheater.

The tender has a C. P. R. standard steel frame and the tank is made with a water bottom. The water capacity of the tank is 5,000 Imperial gallons, which equals 6,000 U. S. gallons, and the coal capacity of the tender is 10 tons. The tender trucks are of the ordinary arch bar style, strongly built. The rear or fireman's cab, is a very substantial affair, being made of steel and completely enclosing the wide fire box. The whole design is neat, and a very serviceable en-

may be. At the other end of the bar there is a universal joint, the center block of which is made of axle steel hardened so as to resist wear, and on the other end there is a standard drill socket which will hold the end of a reamer. The collar on the socket is to enable the man using this appliance to jar it and to have something to strike on in case it is necessary to give it a blow with a hammer. The oblong hole in the socket is for the purpose of inserting a wedge or peg to loosen up the end of a reamer when it is desired to take one out. Mr. James L. Smith, the assistant shop foreman of the Pennsylvania Lines shop at Allegheny, got up the appliance, and those who have used it say it is most convenient and is a time and labor saver. The tool room has this appliance made in several sizes. Before this device was used, the pneumatic drill had often to be held in awkward positions, and frequently could not be used at all in the work of reaming frame and cylinder saddle bolt holes.

One hears no talk of dull times among the workers in Turtle Creek

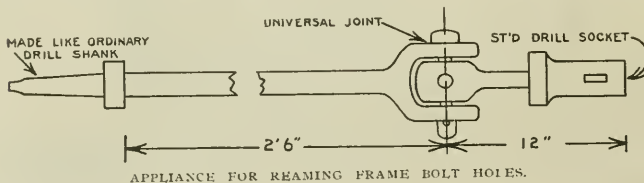

APPLIANCE FOR REAMING FRAME BOLT HOLES.

gine has been turned out. The electric headlight is used on all C. P. R. passenger engines, and as this engine is intended for hauling passenger trains as well as freight, it has been supplied with an electric light. The brakes are Westinghouse straight air on the engine and high main reservoir pressure control. The Gold steam heat equipment is used and Hancock injectors supply the boiler.

#### Useful Adjunct to Pneumatic Drill.

A very useful and easily made shop appliance is here illustrated. It is an adjunct to the pneumatic tool which is commonly used to ream cylinder saddle and frame bolts, etc., and this appliance enables the air driven reamer to be worked in any position and in any place where a hand reamer can be operated.

The device consists of a bar of any convenient length and made of axle steel. On one end of the bar there is a shank which fits the socket of the hand pneumatic machine. A collar is formed close to the shank end, and this is for the purpose of affording a surface for the workman to strike on in order to tighten or loosen the shank, as the case

Valley, locally known as "Westinghouse Valley," owing to the territory being practically covered by the various Westinghouse factories, which extend from East Pittsburgh to Wilmerding and Trafford City, on the main line of the Pennsylvania Railroad. The largest of these is the Westinghouse Electric & Manufacturing Company, covering over 47 acres at East Pittsburgh, where everything electrical is manufactured. Some idea of the magnitude of the business handled at this plant can be formed when it is stated that during the month of October the shipment of electrical apparatus from this factory, exclusive of a large number of local freight and express orders, amounted to approximately 17,000,000 lbs., consisting of over 5,000 individual consignments.

The directors of the education of American youth are favoring text-books of arithmetic and science in which the metric system of weights and measures are employed. It is true that the American parents were roused to realize the waste of efforts their children are called upon to exert in learning a system likely to be of no use to them in after life,

while neglecting to acquire familiarity with the American system of weights and measures that are the basis of their ordinary daily life calculations.

#### Government Control of Rates.

It is interesting to note that the President's plan for federal control of railroad rates has practically been in operation in Canada for several years. In the Dominion the railway act passed in 1903 created a commission having certain powers, among them being the jurisdiction over railway rates.

In a recent interview at Salt Lake City the Hon. H. R. Emerson, Canadian Minister of Railways, spoke of this commission as a public tribunal, having power to adjust all railway rates and remove any discrimination. The commission has all the authority of a court of record and is invested with all the powers and duties of the railroad committee of the privy council.

Continuing, he is quoted as saying: "In the event of the railroad failing to provide the commission with all information as to rates, the commission has the power to fix new tolls and to name the date on which they will go into effect. So far, the commission has not made any move in the direction of altering any general railroad tariff in force on any railroad in Canada, but a large number of charges of discriminations have been considered. In several cases railroads have been ordered to restore old rates which had been increased."

One of the most pretentious books ever written is "Our Country: A Household History of the United States for All Readers, from the Discovery of America to the Present Time," by Benson J. Lossing, LL.D. The book contains about 1,900 pages, 5x7 inches of reading matter on each page, and there is not a word in it about the origin or growth of railroads. The word "railroad" does not appear in the very full index. The petty quarrels among politicians receive detailed attention, but descriptions of the growth of the industries which have made the United States great among nations are evidently considered too plebeian for mention by this LL.D author.

To find volume of auxiliary reservoir, multiply square of inside diameter in inches by .7854 and by its inside length in inches and the product will be the volume in cubic inches.

To find the pressure in brake cylinder, multiply volume of auxiliary reservoir by the pressure in it and divide the product by volume of auxiliary reservoir plus volume of brake cylinder from pressure head to piston when brake is set.

# Our Correspondence School.

In this department we propose giving the information that will enable trainmen to pass the examinations they are subjected to before being promoted. If any of our students fail to understand any part of the instructions, we will gladly try to make them plainer if they write to us. All letters intended for Our Correspondence School ought to be addressed to Department E.

## Our Purpose.

In our Correspondence Schools Department it is our aim to please our correspondents and to give them the full information they desire in questions sent in to us. Being largely guided in the conduct of this department by our correspondent's views, we have concluded from the correspondence received that the better plan to follow is to give the instruction in a way that the correspondent asking for it can use the information immediately, rather than to make a long drawn out course, tiring the correspondent and student before he reaches the part particularly interesting to him. We believe in our practice of answering questions sent to us, thereby making the information submitted immediately available, the student can proceed understandingly with the work which he has in hand for the moment. In addition to this we have endeavored to branch out a little—not too much, perhaps expanding a trifle further than our correspondents have required—but we have confined this to the other part of our correspondence schools, apart from the questions and answers.

We are always glad to make the schools of any special use to our correspondents, the whole scheme being to make it useful to the student and creditable to ourselves.

## First Series.

(Continued.)

19. How many cubic feet of air therefore would be necessary for the burning of a "fire" of four scoopsful, assuming each scoopful to weigh ten pounds?

A.—For four scoopsful of coal, each weighing ten pounds, the quantity of air required for combustion would be  $40 \times 260 = 10,400$  cubic feet.

20. Why is it necessary to provide for combustion a supply of air through the fuel in the furnace?

A.—Because it is only by forcing the air through the burning fuel that the proper mixture of the gases will be effected.

21. How can you prove that it is necessary to supply air to the fire box for combustion?

A.—By shutting off the air supply.

22. What is the effect upon combustion if too little air is supplied through the fire? If too much air is supplied?

A.—If too little air is supplied the fire loses activity and combustion produces carbon monoxide, a gas with only about one-third the heating properties of carbon dioxide, the gas formed when the supply of air is sufficient.

If too much air is supplied waste is caused by heating the surplus quantity of air, and the oversupply tends to depress the fire box gases below the igniting temperature.

23. What effect on combustion has the closing and opening of dampers?

A.—A closing of the damper cuts off the supply of air and prevents the fire from receiving its proper supply of air. Opening the dampers permits the air to pass through the grates. Under some circumstances it is better to keep one damper closed.

24. How is draft created through the fire?

A.—By the current of air induced by the exhaust through the flues and smokestack.

25. Describe a blower and its use and abuse.

A.—A blower is a jet of steam passed up the smokestack to induce an artificial current of air. Its proper use is to prevent smoke when an engine is not working, to draw the fire gases away so that they do not pass into the cab and to stimulate the fire when necessary.

The abuse of the blower is drawing cold air through the tubes and by forcing the fire when it is not necessary, causing waste of steam through the safety valves.

26. What effect is produced by opening the fire box door when the engine is being worked?

A.—It cools the boiler and prevents the rapid generation of steam.

27. What bad effect?

A.—It causes sudden contraction of the fire box sheets and flues, tending to cause leakage.

28. In what condition, therefore, should the fire be in order that the best results may be obtained from the combustion of the coal?

A.—The fire ought to be maintained in the condition necessary to generate the steam required for the way the engine has to be worked. Even firing and even temperature go together.

29. What is the effect of putting too many scoops of coal on a bright fire? Is this a waste of fuel?

A.—Throwing too much coal into a

fire at one time depresses the temperature below the igniting point and causes the generation of smoke. The practice is wasteful of fuel.

30. What effect has the fire upon a scoopful of coal when it is placed in the fire box?

A.—It distils the volatile gases first, then ignites the carbon of the coal.

31. In what condition should the fire be to consume these gases?

A.—Bright and at a high temperature.

32. What is the temperature of the fire when in this condition?

A.—About 3,000° Fah.

33. How can the fire be maintained in this condition?

A.—By regular firing. That is, by keeping up the supply of fuel as nearly as possible at the rate it is burned.

34. What is black smoke? Is it combustible?

A.—It is unconsumed coal and can be prevented by good firing, if the coal is not too volatile.

35. Have you made any effort to produce smokeless firing?

A.—Certainly I have.

36. How can black smoke be avoided?

A.—By careful firing. With some qualities of coal and a plain fire box smoke cannot be entirely prevented.

37. Can the firing be done more intelligently if the water level is observed closely? Why?

A.—The fireman can work more intelligently when he knows that the boiler is being fed regularly.

38. What advantage is it for the fireman to know the grades of the road and the location of the stations?

A.—This knowledge enables him to regulate the firing to suit the fluctuating work the engine will do.

39. How should the fire and water be managed in starting from a terminal or other station?

A.—The fire ought to be made up sufficiently heavy to preclude the necessity for firing while passing through the yards. The boiler ought to be as full of water as can be carried without priming.

40. What is the purpose of a safety valve on a locomotive boiler? Why is more than one used?

A.—To relieve the boiler from over pressure of steam. Two safety valves are used because one is sometimes unequal to the task of preventing over pressure.

(To be continued.)

## Calculations for Railway Men.

BY FRED. H. COLVIN.

As we have already seen, it is very easy to make almost any calculation you want if you start right and don't get excited over it. Let us take up the question of the power of any locomotive, not from an exact point of view, but for comparison when some new engines are coming on the division. Suppose you already have 18x24 in. engines, and the new ones are to be 20x24 in. Here the only difference is in the cylinder diameters, as we assume the steam is the same, also the wheels. We cannot say that the power varies as 18 is to 20, because, with all areas we must remember that "they vary as the square of their similar dimensions." This means, for example, that a square having a side of 4 ins. is not only twice as great as a square of 2 ins., but is four times as great. The side is 2 ins. in one case and 4 ins. in the other. Square 2 by multiplying it by itself and get 4, square 4 and get 16, and this is four times as great as four, although the side is only twice as large. The squares shown in Fig. 1 prove this beyond a doubt.

In the case of cylinders the same thing is true and for the purpose of comparison it is not necessary to calculate the area of each but only to compare the squares of their diameter. Multiplying 18 by itself we have 324, and 20 times 20 is 400, so we know the exact ratio of these cylinders to be "as 324 is to 400," or we can say that if one pulls 324 tons the other will pull 400 tons, everything being the same except cylinder diameter.

This is also useful in finding the ratio between high and low pressure cylinders of a compound locomotive. If the high pressure cylinder is 16 and the low pressure 24 ins., then these are in a ratio of 16 times 16, or 256 and 24 times 24, or 576. Divide 576 by 256, and we find that the low pressure cylinder is 2.25, or 2¼ times as large as the high. If the diameter is twice as large the area is four times as great, but this does not occur in locomotive work.

Grades and curves are always of interest, and there is sometimes a discussion as to how they are designated. In this country it is usual to give a grade as so many feet to the mile in steam railway work, in percentage for street railway and electric work, while in Europe they say a rise of 1 in 50, or 1 in 83, as the case may be.

The percentage designation is really the best in many ways, as we can soon learn to think of 1 per cent. as being a rise of 1 foot in every hundred feet, a 3 per cent. grade as 3 feet in a hundred, and so on.

But what we really want is a means of comparing the different ways so that when we read of 1 in 83, or a 2½ per cent. grade, we know about how it com-

pares with our own road. For this purpose I have made a little table which will prove handy to keep for reference and which shows, for example, that a 2 per cent. grade is about the same as 105 ft. to the mile.

TABLE OF GRADES.

Per cent. of grade.	Rise in feet per mile.	Length of grade to 1 foot of rise.
.1	5.28	1000.
.5	26.4	200.
1.	52.8	100.
1.5	79.2	66.66
2.	105.6	50.
2.5	132.	40.
3.	158.4	33.33
3.5	184.8	28.57
4.	211.2	25.
4.5	237.6	22.22
5.	264.	20.
5.5	290.4	18.18
6.	316.8	16.66

The resistance due to grades is also of interest in these days of heavy tonnage, and we note that the force necessary to move one ton of 2,000 lbs. up a grade of one foot per mile will be 2,000 divided by 5.280, which is the number of feet per mile. This gives .3788 lbs. per ton for this grade, and if the grade is 20 ft. per mile, we multiply .3788 by 20 and get 7.576 lbs. as the force neces-

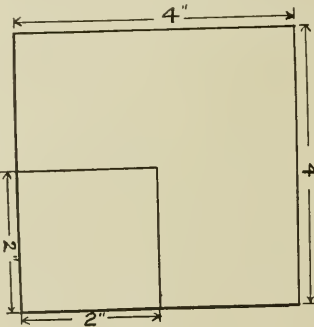

FIG. 1.

sary to overcome the resistance of the grade for every ton of load. This does not take into consideration the hauling of the cars, but merely to the lifting of the weight of the car through this height. This must be added to the resistance of the car per ton on the level. If we have a train of 600 tons and the grade is 80 ft. to the mile, we find the total resistance, due to the grade only, to be  $.3788 \times 600 \times 80$ , or a total of 18,182.4 lbs. for lifting the train through this height on this grade.

Curves also demand attention, and again there are two ways of designating them. One, and the most readily understood, is by giving the radius in feet. The other is that generally used by the civil engineers, in degrees. It is quite easy to compare these two methods from the fact that a one degree curve has a radius of 5,730 ft., and for all practical purposes we can just divide this number by the degrees of the curve and get the radius nearly enough for our use.

In reality this is not quite correct for small radius curves, but the error is very slight.

This means that a 10 degree curve will have a radius of 573 ft., or that we can tell about the degree of curve from the radius by working the rule backward. That is, if we know a curve is 876 ft. radius and wish to find the number of degrees it is, we simply divide 5,730 by 876, and get 6.54 as the number of degrees of curvature.

The resistance to trains, flange friction between wheels and rails, due to hauling a train around a curve is generally taken as being .5682 lbs. for every ton around a one degree curve. This is the same as the resistance due to a straight grade of 1½ ft. per mile, and can be easily remembered in this way. For a 6 degree curve we multiply .5682 by 6 and find the resistance to be 3.4092 lbs. per ton, so that if this curve should occur, on the grade we considered in the last problem, we would have 600 times 3.4092, or 2,045.52 lbs. to overcome the curves only, and which must be added to the resistance due to grade, so that, without counting the rolling friction at all, we already have train conditions requiring a drawbar pull of 20,227.92 lbs. in addition to that required on the level. This shows why grades and curves count so much in the performance of a locomotive.

Frictional resistance is usually considered from 6 to 7 lbs. per ton, so that it is probably fair to call it 6.5 lbs. For our 600 ton train this would give 3,900 lbs., making a total of 24,127.92 lbs. drawbar pull required. This makes no allowance for speed, as the resistance due to speed becomes a more complicated problem and it is hardly likely that an ordinary engine with this train would run fast enough up an 80 ft. grade to make the question of speed an important one. A drawbar pull of over 24,000 lbs. with the reverse lever back where it has to be to handle a train on most roads, is a pretty good engine, as you can easily prove if you look around at the heaviest grade on your own road, unless you happen to be in the very mountainous districts.

These are problems that interest any railroad man who is not content with knowing "just enough to hold his job," as has been said of too many men. Get posted on things that may not be in your direct line of work, just for a recreation if for nothing else. You will find it interesting, and it may come in very handy some of these days.

To find number of strokes of air pump piston required to pump 90 pounds in main reservoir, multiply volume of reservoir by 6 and divide by volume of air cylinder. Leakage and change of temperature not considered.

GENERAL

# Questions Answered

SLIPPING OF DRIVERS.

(1) C. A. H. writes:

In referring to those two similar engines in your last issue, Mr. Allen claims that the engine with the largest wheel will slip the easiest, which is contrary to my experience. Is this true, and if so, why is it? A.—Given the same rotative effort, our experience is that small driving wheels will slip more readily than large ones.

STRENGTH OF A WORM GEAR.

(2) L. C. B., Covington, Ky., writes:

How do you figure the strength of a worm gear? How much stronger is a worm gear than a cog gear? A.—A worm gear is not as strong as a cog or spur gear. The advantage of a worm gear is that the worm and wheel are so constructed that the worm will drive the wheel, but the wheel will not drive the worm. Repeated experiments have shown the advantage of spur-gearing over all other kinds of gearing. The variation in power is not over 5 per cent. until cutting of the teeth, induced by high velocities, begins. The loss of power then varies rapidly. The excessive friction of a worm gear is due to the end thrust on the collars of the shaft. This can be reduced by roller bearings. Even with light loads worm gearing will begin to heat and cut if run at a high speed, the safe limit being about 200 ft. per minute. The spur wheel will keep cool as the teeth have a much larger radiating surface. The smallness of the worm induces the suppression of heat and consequently it is dissipated slowly. Whenever heat increases faster than it can be conducted away cutting of the worm begins, and cutting means a loss of power. The efficiency of worm gearing varies also with the number of teeth in the worm. With two threads the calculated efficiency will be .67, with three threads .75, with four threads .80. The exact relation of efficiency between spur pinion and worm gearing at an equal velocity of 100 ft. per minute at the pitch line is, in the case of spur pinion, .98, and in the case of spiral pinion or worm, .82.

We have an eight-wheel American type passenger locomotive that is cutting the driving wheel flange for about 32 ins. on the part nearest the crank pin. The engine is just out of the shop, and the remainder of the flange is wearing straight. What is the cause of this? A.—There are several causes that could produce this effect. A bent axle is one

of the chief causes of the irregular wearing of flanges. This is generally accompanied with heating in the driving boxes, and if no indications of heating is manifested, it is safe to assume that there is a deflection in the rim of the wheel which may have been caused during the process of pressing in the crank pins. Wheels of large diameters are sometimes slightly bent and not infrequently cracked by careless adjustment of points of resistance while the axles and crank pins are being pressed into place.

COMPOUND INDEXING.

(3) E. E., Mattoon, Ill., writes:

Please explain the art of figuring compound indexing for a gear wheel with 73 teeth. A.—In indexing on a machine for cutting teeth in a gear wheel the question simply is: How many divisions of the machine index have to be advanced to advance a unit of the number required? Suppose the number

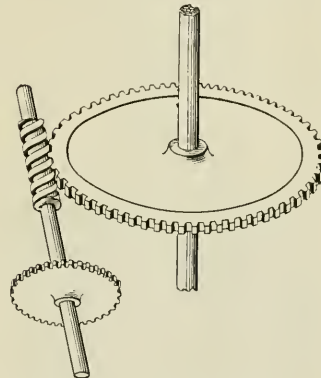

INDEXING FOR GEAR WHEELS.

of divisions in index wheel of machine to be 180. Divide 180 by 73 (the number of teeth required) =  $2\frac{2}{3}$ , the number of turns required on worm wheel. Now, if we have a worm wheel with 365 teeth the problem would be a simple one, as

$$\frac{34}{73} = \frac{170}{365}$$

Hence, 2 turns of the worm wheel and 170 teeth of the 365 in the worm wheel index would be the exact division for a wheel containing 73 teeth.

But supposing the number of teeth in the worm wheel index was 220. Then

$$220 \times \frac{34}{73} = 102\frac{34}{73}$$

This would necessitate 2 turns of the worm wheel and 102 teeth of the 220 teeth in the worm wheel index for the first tooth of the 73 required, and 2 turns and 103 teeth for the second tooth, and so on alternately until the completion of the 73 teeth.

This is the nearest approach to accuracy with a worm wheel of 220 teeth, and involves a fractional variation in the size of the teeth amounting to .000466 too small for the first tooth, and .000534 too large for the second tooth, and so on. This variation would not be discernible in commercial practice.

It may be added that the fractions are occasionally of such a kind that the difference is made up in every third or fifth or seventh tooth as may be necessary to approximately equalize the fractional variation.

RETARDING FLOW OF AIR.

(4) J. S. B., Vilas, Lycoming Co., Pa., writes:

1. It is supposed that an ell in a train pipe will retard the flow of air as much as 7 ft. of train pipe. If so, would it not be advisable to have large or long ells so as to have a gradual curve similar to a bent pipe? A.—The amount of frictional resistance which a 45° ell offers to the flow of air in a pipe depends on the diameter of the ell and of the pipe, and is greater the smaller the diameter. For 1 in. pipe, an ell offers a resistance about equal to that of 15 ft. of 1 in. pipe.

As few ells and bends as possible should be used in the brake pipe, and where bends are necessary they should be long and easy, and not reduce the diameter of the pipe appreciably.

2. Why is 1 in. pipe used on passenger coaches and all the engines when it is necessary to have 1¼ in. pipe on freight cars? In my opinion it don't seem right to make a train pipe reduction through a 1 in. pipe on the engine and tender, and cause equal effect on a train where 1¼ in. pipe is to be exhausted, as is the case with modern freight trains. A.—On passenger equipment 1 in. pipe has always been found satisfactory. As freight cars are considerably shorter than passenger cars, to give them the same brake pipe volume as is had on passenger cars, it was necessary to increase the diameter of the pipe to 1¼ ins. On account of the much greater length of freight than of passenger trains there is the added advantage of reduced friction in the flow of air through the larger pipe.

In emergency applications but a small portion of the brake pipe air passes out through the brake pipe and brake valve on the engine, on account of it being vented directly into the brake cylinder. In service applications the air must be exhausted slowly at the brake valve. Hence no advantage is had in the operation of the brake, either in service or emergency. However, for the sake of uniformity in pipe fittings and couplings, some roads are applying 1¼ in. pipe to the engines and tenders.

3. Suppose a 1¼ or a ¾ in. induction pipe was used on freight engine, would

this act as a slower or more gradual application of those brakes, and allow a long train to apply brakes on cars before the heavy surge would take place, caused by the heavy engine and tender, before brakes are applied on all cars? In releasing, the  $\frac{1}{4}$  in. pipe would act as a retarder, and cause the brakes on the engine and tender to release slowly, and would give the brakes on the cars of a long train more time to release before springs in drawhead would move engine forward, and would prevent heavy surges and parting of a good many freight trains. A.—It is quite likely that a  $\frac{3}{8}$  in. pipe connecting the triple valve and the brake cylinder, if of considerable length, would offer sufficient frictional resistance to the auxiliary air to reduce the rate of increase of pressure in the brake cylinder in service applications, and it would also be likely to retard the release of the brake somewhat. In emergency applications, equalization would be had very little, if any, quicker than it would be in service, and a quick release of the engine and tender brakes is often necessary. Hence it is easily seen that there are several objections to the use of pipe of such small diameter as  $\frac{3}{8}$  in. to connect the triple and the brake cylinder. Three-quarter inch pipe is now considered none too large for this purpose.

To prevent breaking in two of long trains when releasing brakes, the combined automatic and straight air brake, on the engine and tender, is nowadays extensively used, and the new Westinghouse engine and tender equipment is also designed to enable the engineer to manipulate the brakes both on the engine and the train, according to the demands of circumstances, so as to prevent violent shocks and the danger of breaking the train in two.

#### CURIOUS BEHAVIOR OF STEAM GAUGE.

(5) A. C. E., Danville, Ill., writes: I was running a Pittsburgh cross compound with Wootten fire box and centrally placed cab. Boiler pressure 200 lbs. I was pulling out of yard when I noticed gauge showing 220 lbs. I thought safety valves were stuck, looked at water glass, it was full, went on top and pounded pops with no result, when I came back gauge showed 260 lbs. Put injector on and started to take it out of her, but gauge pointer kept on until it was clear around, it passed the 350 mark, and stopped against the pin. I remembered that the fireman had a gauge, asked him about the pressure and he said 180 lbs. In about five minutes my gauge pointer began to go back. I had previously pounded my gauge. What was the matter? A.—The action of your gauge pointer was not due to boiler pressure. One possible explanation is that a small piece of hard cinder got between the quadrant and pinion on the upper side and acted like the pawl of a

ratchet. Any vibration of the pointer due to the engine's motion could only move the pointer up, and the cinder held it there and so on until the pointer was all the way round and the pinion at the end of the sector when it dropped out and the coil spring brought the pointer back again.

Another explanation is that heat caused the false reading. There are some gauges made without siphon pipes, and such a gauge might act as yours did, due to water leaving the parts which are supposed to remain filled and allowing hot steam to come in contact with the walls of the spring pipe or flattened tube. After a while sufficient steam would condense and fill this chamber and allow the tube to return to its normal state.

Even with a syphon pipe a gauge might give a false reading if the syphon cock had been accidentally shut and a lighted torch laid down so that the flame came in contact with the syphon pipe, and was subsequently taken away.

#### BRAKING FORCE.

(6) J. A. J., Corbin, Ky., writes:

I would thank you for information concerning the following, as I claim they are all wrong:

1. An engine, weight on drivers, 120,000 lbs., is equipped with 12 in. cylinders and a 12x33 in. auxiliary. The cylinder lever is  $31\frac{1}{2} \times 5$  ins. What is the proper size equipment for this engine, and what is the present braking force? A.—The proper size equipment for this engine is, brake cylinder diameter, 14 ins.; auxiliary reservoir, 16x33 ins.

With its present equipment, the piston travel normal, the auxiliary and brake cylinder will equalize at approximately 46 lbs. Its present braking force, therefore, may be taken as about 65,500 lbs., or 55 per cent. of the weight on the drivers.

2. An engine, weight on the drivers, 125,000 lbs., 12 in. brake cylinder, 12x33 in. auxiliary reservoir, and cylinder lever  $39 \times 5$  ins, same as above? A.—This engine should have same equipment as the other. With its present equipment, the braking force is approximately 81,167 lbs., or 65 per cent. of the weight on the drivers.

3. An engine, weight on drivers, 137,000 lbs., 12 in. brake cylinder, 16x33 in. auxiliary reservoir, and cylinder lever  $31\frac{1}{2} \times 5$  ins, same as above? A.—With this equipment, piston travel normal, the auxiliary and brake cylinder will equalize at approximately 54 lbs. The braking force will be, therefore, about 76,885 lbs., or 56 per cent. of the weight on the drivers.

4. Some of the 125,000 lb. class have 12x33 in. auxiliary reservoirs, and some 14x33 in. auxiliaries; some of the 137,000 lb. class have 14x33 in. auxiliaries, and some 16x33 in. reservoir. They seem to show no difference in braking, or,

rather, are giving no trouble. In what way does 16x33 in. reservoirs not work in harmony with 12 in. brake cylinders, and what injurious effect does it have? A.—A glance at the percentage of braking power, as given above, would indicate that no trouble from slid wheels should be expected, as the highest percentage shown in considerably under that which is commonly used, unless the engines are of the compound variety.

Auxiliary reservoirs and brake cylinders are so proportioned to each other that with normal piston travel a reduction of 20 lbs. in the standard brake pipe pressure will equalize them. Therefore, if the auxiliary reservoir is too small for the brake cylinder with which it is used, too heavy a brake pipe reduction will be required to equalize them; if too large, they will equalize with too light a brake pipe reduction. Either is not satisfactory.

Where the equipment is smaller than that recommended, the total leverage must be increased to produce the required braking power; and this means reduced shoe clearance and more frequent adjustment of slack.

5. Can you approximate the length of stop, working quick action on a 2 per cent. grade, 50 ton engine, cam driver brake, 8 in. cylinders, tender brake 8 in. cylinder (ordinary size tender), 6 freight cars, empty, and brakes on two rear cars cut out? A.—Not with the data which you give. To make an approximate guess at the distance required to stop in we should want to know at what speed the train was moving when brakes were applied, the braking force used on the engine, the tender, and the cars, the kind of brake shoes used, etc., and then we should have to assume all other conditions normal.

(Continued on page 27.)

A good calendar, and one which is suitable for office use, is one which has the figures indicating the days of the month printed in heavy block type which can be easily seen across an ordinary room. Such a calendar for 1906 has been got out by the Star Brass Manufacturing Company, of Boston, Mass. The size of the sheets are about 18x24 ins., and the calendar part is kept separate as far as the printing is concerned from the space used by the company to announce that they make lamps and car trimmings, pop valves, whistles, steam gauges, rod cups, water gauges, cylinder relief valves, gauge cocks, etc. Each of the figures in the calendar is enclosed in a space about 2 ins. square, and the whole is printed in plain black and white. A calendar like this is good for a shop as well as an office. Write to the Star Brass Company for one while yet there is time. Mention that we advised you to also write for a catalogue.



# Air Brake Department.

CONDUCTED BY J. P. KELLY.

## Testing High Speed Brakes.

Complaint is heard occasionally of undesired emergency resulting with the high speed brake when a service application is being made, and this after the terminal test of the brakes indicated that everything was working properly and that all triple valves were in good condition.

Investigation of these complaints shows that the terminal test of the brakes in the majority of cases was not properly made. For instance, at one terminal point with which we are familiar, the pressure available for charging the train and testing the brakes is not more than 70 lbs., and sometimes is a little less. With this pressure everything works well, and the brakes, after testing, are pronounced all right and in perfect working order. At the last moment the locomotive that is to take the train out backs up and couples to the train, the hose are united and the angle cocks opened, but long before the auxiliaries are charged to 110 lbs., the high speed pressure, the brakes are applied and released from the brake valve, working properly for that pressure. Then the train pulls out and after awhile the pump has charged up to 110 lbs., so that when the engineer makes his first service application on the road, he is sometimes surprised to find the brakes going into quick action, and wonders why they do it, since in the test he made before starting out, they apparently worked all right.

Well, the fact is, they should have been tested at the terminal with 110 lbs. pressure instead of 70 lbs., as was done in the cases we have in mind. Then the same condition would be had that the brakes are to work under in actual service, and the exact condition of the triple valves could be correctly ascertained. It may not be out of place here to remark that all tests made to determine the condition of the brake should be made with the maximum pressure used, conforming to actual service conditions under which the apparatus is to operate.

When testing high speed brakes, therefore, either with the yard testing plant or with the engine brake valve, the auxiliaries should be charged to the full pressure, 110 lbs., before the service reduction for the test application is made. Then, if there is a dirty or sticky triple in the train, or one not sufficiently sensitive to move promptly when a service reduction is made, it can be detected,

and the proper remedy applied before the train gets out on the road.

Frequently the trouble experienced from undesired emergency is not due to the faulty condition of the triple valve, but to the condition of the brake valve on the engine, and the leaky condition of the air gauge and equalizing reservoir connections.

The equalizing discharge piston of the brake valve should be kept clean and in condition to respond promptly when a service reduction is made from chamber *D* pressure, and all the pipe



"OILING ROUND" ON A STOP FOR WATER,  
CANADIAN PACIFIC RAILWAY.

connections to chamber *D* and the equalizing reservoir should be kept absolutely air tight. This is especially important when using 110 pounds pressure, since a slight leak is more effective in quickly reducing chamber *D* pressure 8 or 10 lbs. from this initial pressure than it is from that of 70 lbs.

The service exhaust elbow should never be omitted from the brake valve, since it modifies the exhaust by mildly reducing its rate of flow. This tends, of course, to prevent the quick movement of triples, which might cause them to go into quick action.

Where trouble has been experienced from undesired emergency, when the application was made from the engine, careful investigation of the condition of the brake valve, followed by the applica-

tion of the necessary remedies to put it in proper shape, has resulted in eliminating the objectionable performance of triples in high speed service. Following up the triples it has been found that where they were at fault, they were in the majority of cases overdue for cleaning and oiling. Cleaning them up, and lubricating them sparingly with some good lubricant, such as Dixon's Triple Valve Grease, has cured the trouble entirely.

## Parting Hose by Hand.

This is a matter that has been much discussed by those interested in maintaining a high efficiency in air brake operation, but how to get it done is a problem that has never been satisfactorily solved.

Yard switchmen do not think they can take the time to part hose by hand, and roadmen are careless in the matter, not appreciating to the extent which they should the damage that is done, not to the hose alone at the time they are pulled apart, but subsequently when a hose weakened by such treatment ruptures in a moving train, and causes it to break in two, producing delay and doing more or less damage to the cars and lading.

It is this delay to trains and damage to cars and lading more than the damage to the hose that is now an important matter for correction.

While in conversation recently with the superintendent of one of our big lines, he informed us that he had made it his practice for over a year past to hire men for the special work of separating the hose, where necessary, on all trains coming into the yards.

That is their special duty, and he further informed us that it is a good paying investment to hire as many men as may be necessary to perform this work. Since the company considers the parting of hose by hand a matter of sufficient importance to hire men for this special purpose in the yards, the moral effect on the trainmen on the road is such as to induce them to make a little greater effort than formerly to part the hose by hand whenever separating the cars.

A pair of hose and fittings cost about \$3.25. On a train of 50 cars this would bring the total value of the hose and fittings up to a little over \$160. The man hired to part the hose by hand may be had for \$1.50 or \$1.75 per day.

Taking the saving in hose and fittings

alone into account, it is easily seen that the plan has considerable merit to recommend it. When the saving in time and the prevention of damage, caused by ruptured hose, to trains on the road as well as the prevention of brake pipe leakage is also considered, it means that the employment of men for the sole purpose of parting hose by hand is a wise move in railroad operation.

#### Keep the Pump Strainers Clean.

Many air pumps, especially at this season of the year, commence to show signs



CANADIAN PACIFIC RAILWAY TRANSCONTINENTAL TRAIN AT FIELD, B. C.

of falling off in capacity to accumulate the standard pressure in the proper length of time, apparently without good reason, and without an intelligent investigation as to the cause of this lack of air making capacity are often condemned as being in bad condition.

It has been our experience upon investigating many of these cases that the pump strainers are so clogged up that but very little air can get through them. Hence the pump, although the air cylinder, piston packing rings, and air valves are in good condition, is unable to produce the required pressure in the usual space of time. We have seen pumps come in with the strainers smeared over with valve oil. In cold weather, valve oil will quickly freeze solid and clog the meshes of the strainer so effectually as to exclude all air.

It would hardly be reasonable to expect a pump thus treated to be able to recharge a train after a brake application in the usual time required. It should, therefore, be borne in mind that it is very important to keep the air strainers clean and all of the perforations open so that air can be freely admitted through them.

While this is important, generally considered, in heavy grade service, clean strainers are of the utmost importance in order that the pump be able to recharge the train quickly. Do not pour valve or any other kind of oil over the strainer in the hope of improving the action of the pump, for in cold weather it will only serve to put the pump out of commission.

#### Air Brake Recording Plate.

Editor:

This plate is to be used for the purpose of showing the date of the cleaning of triple valves and cylinders. By referring to the drawing it will be seen that this plate is arranged to be hung under the car, at any suitable place, where it can be seen easily from both sides of the car.

In applying it to a car, there is two small castings put on the sills with lag screws or rivets. These castings are similar to the flag holders on passenger cars. The plate is hung from these castings by the aid of the brackets at the top of the plate, and when put on does not require any fastening.

The pocket at the bottom is for air brake defect cards, and it is open so that the cards can be seen from both sides of the car. The pocket is made of suitable size to hold the defect cards.

When it is to be used on passenger cars, there can be another line put on for the high speed valve. The letters on the plate can be either cast or painted. There is plenty of room for the full date and the name of place.

In using this plate, when a triple valve or cylinder is cleaned or exchanged, the plate is taken off and another one, which has been properly stenciled for that date, put on in its place, or, in other words, the plates are exchanged the same as the triple valves.

Some of the reasons why a device of this kind is required, are that on a great many of the passenger cars, the reservoirs and cylinders are placed where they

it makes a bad looking job, if the reservoir is not painted before the stenciling is put on; again, it takes up time waiting for the paint to dry. In some cases when triple valves are exchanged out in the yards, there is not time to spare to have the reservoir painted. This item of stenciling the dates has not received the attention it should, but it will become more important in the near future, as the new conditions will demand something of this kind.

In handling the defect card, this plate will save lots of time, as all it is necessary to do, is to drop the card in the pocket, and you do not have to hunt for tacks, or hunt for the card if the car has a defective brake.

The plates are to be stenciled in the shop, at any convenient time.

The plates will not cost much, but the time saved by its advantages will more than pay for the first cost.

To sum up the different points:

It prevents delay and time in stenciling.

It saves time in handling the defect cards.

It is necessary on cars where the reservoir cannot be seen.

Can be exchanged in a few seconds.

The stenciling can be done better and more satisfactorily.

Gives plenty of room for putting on the date.

JOHN HUME.

#### Efficient W. A. B. Apparatus.

"To have graduated release, quick recharge of auxiliary reservoirs, quick

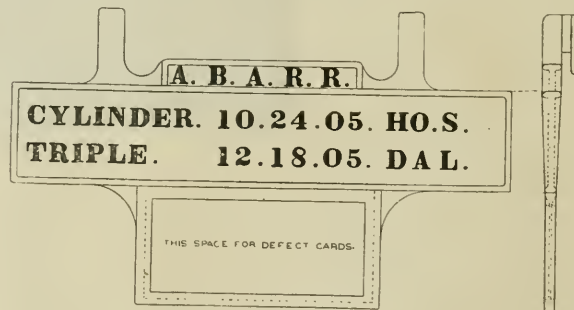

AIR BRAKE RECORDING PLATE

cannot be seen, because they are obscured by the gas reservoirs or by some other obstruction. On a great many of the new steel cars, the reservoirs are placed close up to the sills, and in some cases the stenciling cannot be put on.

There is not room enough on the cast iron reservoirs for a proper date.

It is an awkward job to stencil under a car, and takes up more time than necessary.

When the old dates are scraped off,

serial service application, no overcharging of brake pipe, prompt response of triple valves after full release, and a single train pipe only to accomplish all this is almost beyond belief."

The above is the remark made by a prominent railroad official at a recent club meeting, while discussing the improvements made in the Westinghouse air brake apparatus, and the results of the air brake demonstrations made some time ago at West Seneca.

**Necessary Precaution.**

We have noted while watching air brake inspectors at work taking up slack, and making repairs to the foundation gear of cars that were in trains, and charged with air, that they do not cut out the brake while thus engaged.

While very few accidents have oc-

urred to inspectors because of neglect to take this important precaution to protect themselves, yet there is a possibility of the brakes applying, since it is automatic, without the inspector's help, and of his losing a few fingers or perhaps sustaining greater injury. To be on the safe side when taking up slack or applying brake shoes, the brake should be cut out. It is only the work of a moment to do this, and when the repairs are made, the same to cut it in.

the boiler. To make this experiment work well, however, the engine should be towed at a fairly good rate of speed.

2. How would you manage with a burned or broken grate? How, if entirely gone, with deep ash pan? A.—With shallow ash pan, a support of bricks and other like material may be

rounded with dead ashes, then using brick or stone on top of that until space left by burned grate is filled, will enable one to get the train in. With burned grates, it is generally the case that the ash pan is full of ashes and fire, that will furnish a foundation on which to lay a few bricks or flat stones which will hold the fire in the box fairly well.

3. How would you disconnect if lower rocker arm became broken? and how for a broken transmission bar? A.—If either rocker arm breaks, cover the steam ports with the slide valve in the usual way, then clamp the stem so that the slide valve cannot move. Disconnect the main rod from the crank pin, and push crosshead as close to the cylinder end of guides as it is possible to get it, blocking it there securely. If the guide yoke is of such design that it will not support the main rod, the rod will have to be secured to the running board, boiler brace, or some other part of the engine, to make it clear the ground. Remove all loose parts that might interfere with the motion of the rest of the machinery, block the cylinder cocks open on the disabled side, and proceed, using the other side. If, as is usually the case on modern heavy engines, there are any compression valves in the cylinders, these may be removed, and the disconnecting of the main rod be omitted, care being taken to keep the cylinder well lubricated while the engine is in motion.

4. If a transmission bar breaks, pro-



RESULT OF DEFECTIVE TRACK ON AN ENGLISH RAILWAY.

built up, upon which the burned or broken portions of the grate may be supported until the completion of the trip. With a deep ash pan and grate entirely gone, one would find it neces-

sary to close the space left by the burned grate with whatever suitable material he could find at hand. Filling the ash pan with ashes, if available, to nearly the level of the grates, or with short pieces of heavy timber sur-

ceed the same as for the broken rocker arm, being careful to remove the broken parts, so that all danger of interference with the moving links and link block will be removed.



RESULT OF DEFECTIVE TRACK. SCENE SHOWS HEDGEROWS USED INSTEAD OF FENCES IN ENGLAND.

**General Questions Answered**

*(Continued from page 24.)*

(7) H. B. A., Chadron, Neb., writes:

1. Can a boiler be refilled while an engine is being towed? If so, how? A.—Yes. Fill the tender full of water, leaving the tank lid off; block all release valves in the steam chests, so that no air can be drawn in through them by the pistons; close tight the overflows to injectors and open their steam and water valves; place the reverse lever in the "corner" notch to accord with the direction in which the engine is being towed, and open the throttle valve wide. With this arrangement the pistons will, if all boiler fittings and rod packings are fairly tight, pump a vacuum in the boiler; then the air pressure, acting on the surface of the water in the tender, will force it through the injectors and injector steam pipes into

the boiler. To make this experiment work well, however, the engine should be towed at a fairly good rate of speed.

2. How would you manage with a burned or broken grate? How, if entirely gone, with deep ash pan? A.—With shallow ash pan, a support of bricks and other like material may be

5. What would be the result if guides and crossheads were not in line? A.—Unless fitted very loosely, they would be likely to run hot, and spring or break.

6. What is superheated steam? A.—It is steam heated to a temperature above that corresponding to its pressure, when in contact with the water in the boiler. Various devices, known as superheaters, have been invented to transmit heat direct to the steam, after it is formed in the boiler, for the purpose of increasing its temperature. From superheated steam there is less cylinder condensation, and more work is derived. See page 360, August, and page 424, September, numbers of RAILWAY AND LOCOMOTIVE ENGINEERING, for further information on superheated steam.

7. How fast should an air pump be run? A.—As fast as the work required of it demands, up to 60 double strokes per minute, after the pressure in the main reservoir is 40 lbs. or more.

8. Does the black band of the air gauge show train pipe pressure at all times? A.—Yes, although it is not connected directly to the brake pipe, but to the equalizing reservoir; and these two pressures are always equal, except when the engineer is in the act of making a service application.

9. On a passenger train of 10 cars, when should the brakes be released? If they should be left on until train stops, why are they left on? A.—After the train stops. The best method of stopping a passenger train of 10 cars, in service, is that known as the two-application. Make the first application with a service reduction heavy enough to stop the train three or four car-lengths short of the stopping point, unless released. Then release when the speed has reduced to 10 miles per hour or so, by placing the handle all the way over in release position, and bring the train to a stop at the desired point with a second light and final application, which should be held on until the train stops. This is done to prevent danger of breaking in two, which might occur if a release were attempted from a heavy service application just as the train were coming to a stop. On account of the second application being a light one, no lurch of consequence will be felt because of not releasing until after the stop is made.

10. In making a test with train standing, can you detect if any brake in train sets in quick action? Explain. A.—Yes. Hold your hand under the brake pipe service exhaust ell, in brake valve, and note while the service exhaust is taking place whether there is a sudden closure, or cut-off, of this exhaust, accompanied by a falling of the black hand on the air gauge, or not. If there

is, it is a sure case of a "kicker" among the triples, that has gone into quick action.

#### TRACTIVE POWER AND NUMBER OF WHEELS.

(8) K. J., of Chicago, writes:

1. Does the number of driving wheels have no bearing on tractive power? Would an eight-wheel engine have the same tractive power as a consolidation, supposing both had the same size cylinders and drivers and carried the same pressure? A.—The calculated tractive effort of both engines would be the same. The number of driving wheels has nothing to do with the case. Their number is determined by another and equally important consideration. Suppose you fix upon a certain calculated tractive effort as the one you require for your engine. Multiply this amount by 4 or at most 5 if you want to take no chances on engine slipping. That new figure is the total weight which you can put upon the drivers, and you design the engine accordingly. Here axle load and weight on track come in for consideration, and the size of boiler necessary to do the work. There are a lot of interdependent things which have to be thought of in designing an engine. If you wish to know why you should not go above five times the tractive power to get the adhesive weight, read the article published on page 20 of the January, 1903, issue of RAILWAY AND LOCOMOTIVE ENGINEERING; it is called "The Frictional Limit."

2. Can you tell me how the formula varies where the locomotive is an ordinary compound or a balanced compound? A.—The formula for calculating the tractive effort of a compound is not dependent on whether the engine is balanced or not.

3. What relation does tractive power bear to train resistance? A.—Tractive power does not bear any relation to train resistance. Tractive power is draw bar pull, it is what the engine can do. Train resistance is what you give it to do, and there is no mathematical relation between the two.

#### Mechanical Engineers' Meeting.

The winter meeting of the American Society of Mechanical Engineers was held in New York early last month, and there was a good attendance, but we do not understand what induced the members to go to the meeting unless it was the gregarious instincts of the human race. There was remarkably little in the proceedings that could have been interesting to rational mechanical engineers.

The Society is about twenty-seven years old and has the most eminent mechanical engineers in America on its roll of members. During the first half of its existence the Society displayed considerable vitality if it was

ridiculously conservative concerning endorsement of engineering standards and practices; but of recent years the management seems to have become imbecile and the proceedings have degenerated year after year until the papers and discussions are now rarely of any interest except to the compilers and their immediate friends. The papers now consist largely of these prepared by college graduates or the facts collected for such productions; of investigations into some industrial subject by interested parties; of theoretical disquisitions on dry as dust subjects the authors have no practical acquaintance with, and of papers intended to secure free advertising. The limited scope of the current aims of those who now manage the Society may be judged from the fact that among the listed papers prepared for the December meeting, not a single subject related to marine, locomotive or electrical engineering. Yet this organization vegetates under the name of the American Society of Mechanical Engineers.

#### Defective Addresses.

Among the various classes of people who are moved to communicate with RAILWAY AND LOCOMOTIVE ENGINEERING there are persons who have a very vague idea of how a letter ought to be addressed. Letters intended for this office sometimes fail to reach it, owing to defective addressing, but it surprises us frequently to see the keenness of the New York Post Office people in identifying letters with ridiculous addresses intended for us. This is a city of over four million inhabitants, yet letters reach us daily addressed Angus Sinclair, New York. That seems easy for the letter distributors, but much harder cases reach them, such as "Locomotive Questions, New York." To-day we have received a letter addressed "Congers Book Department, Locomotive Management and Engineering Company, New York." That is rather a far-fetched address, but the letter came without any delay. The distributing department of the New York Post Office has our admiration.

#### Training Youths to Think.

Anything that trains a boy to think and to think quick pays; anything that teaches a boy to get the answer before the other fellow gets through biting his pencil, pays.

College doesn't make fools; it develops them. It doesn't make bright men; it develops them.

Some men are like pigs, the more you educate them the more amusing little cusses they become, and the funnier capers they cut when they show off their tricks. Naturally the place to send a boy of that breed is to the circus, not to college.—Gordon Graham.

### Exhausting the Nation's Heritage.

There has been a great deal of discussion going on lately about the desirability of restricting or regulating immigration. The National Civic Federation held a three days' convention in New York to discuss the various phases of immigration. Some of the people who took part seemed to think that the United States ought to invite the pouring of immigration to our shores at a rate that would soon fill up every vacant spot on this continent, while others wanted restrictions put upon immigration that would practically exclude all foreigners and leave America to the Americans. The old Know Nothing spirit is by no means extinct.

The annual report of Frank P. Sargent, Commissioner General of Immigration, has just been published, and the old chief of the Locomotive Firemen's Brotherhood says some very sensible things. The report is devoted mainly to a protest against present alleged abuses of the laws governing the admission of aliens, and the transportation companies are criticized for irregular methods said to be utilized by them to induce immigration to this country. Commissioner-General Sargent declares that laws should be enacted to compel steamship companies to observe in good faith the statute which forbids them to encourage or solicit immigration to the United States.

### Old Books in New Dress.

Those of our readers who intend to send us orders for books during the year should remember that a couple which may appear on an old list are out of print. One of these is the small twenty-five-cent paper cover edition of Conger's Air-Brake Catechism. This book cannot be bought. We now have an enlarged edition which is thoroughly up to date. It is bound in cloth and the price is \$1.00.

Another book which is out of print is the old twenty-five-cent edition of Questions and Answers on the Air Brake. We have in its place a new and revised edition called Standard Progressive Questions and Answers on the Air Brake. The price of this book with paper cover is \$1.50, and when bound in leather it costs \$2.00.

The man who hesitates to try a new way for fear it will not improve on the old method is never likely to make his mark on the world.

To find revolutions of drivers per minute, multiply 5,280 by the quotient found by dividing the speed in miles per hour by 60; then divide this product by the diameter of the drivers in feet multiplied by 3.1416.

### Economical Ash Handling.

One of the most important features in connection with the dispatching of locomotives at roundhouses is the ashpit and the means for removing the ashes from the pit, and loading them onto cars.

To overcome the difficulties incident to shoveling the ashes, various improvements have been introduced. In some cases buckets have been placed in the pit to receive the ashes direct from the pan, and when the engine was moved off the pit the buckets would be hoisted and dumped onto an ash car, and the bucket returned again to the pit, but until the buckets were replaced, another engine could not come on the pit. Other arrangements have been made where a bucket on wheels would run down rails on an inclined plane, entering it from the side, by going underneath the rail.

of shoveling stands at the side of pit on the same level as bottom of pit, and in order that he will not have too high a throw for ashes, the ash car track is depressed, the rails being about on a level with bottom of ashpit. With one shoveling, therefore, the ashes are thrown from bottom of ashpit onto the car. With this kind of pit, there need be no delay to engines, but it is expensive.

The accompanying illustrations give different views of the ashpit designed and patented by Mr. C. R. Ord, master mechanic of the Atlantic division of the Canadian Pacific Railway, at McAdam Junction, N. B. and it is claimed by the inventor that all the objections found with other methods have been overcome in this device. Fig. 1 shows the loaded bucket partially hoisted over further track, and man in the pit is pushing a spare empty bucket into position under

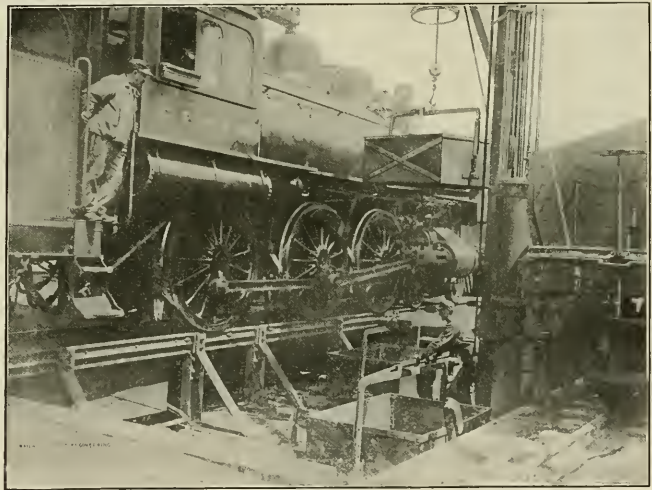

FIG. 1. LOADED ASH BUCKET HOISTED READY TO SWING OVER ASH CAR.

This form, though it would not keep an engine waiting while the full bucket was being drawn out, worked from one end of ashpit only, and a second apparatus of the same type was needed to dispose of the ashes at the other end of ashpit. It would dump the ashes on car at the same point each time; thus the car would need constant shifting. The arrangement was further objectionable, as the rails upon which the bucket ran upwards extended over the ash car track, preventing a high car or an engine coming on that track.

There is another form of ashpit known as the open side ashpit, with depressed ash car track. This pit has the rail on one side supported on columns or standards, and the ashes can be shoveled out from the sides; the man doing the work

ashpan formerly occupied by bucket seen in the air. Fig. 2 is a view of ashpit with locomotive standing beyond. One loaded bucket has been drawn from under the rails, and is about to be hoisted, crane cable being hooked onto it. The other loaded bucket can be seen between the rails; aprons secured to each rail prevent ashes from falling outside of buckets when raked out of ashpit. The spare empty bucket is standing at the outer part of the pit. The guides for directing the buckets onto rails after they have been emptied can also be seen. Fig. 3 gives a view of the ashpit with one bucket hoisted and swung directly over the ash car, a man is standing at the lever, by which the crane is swung, his left hand is on the lever for the dumping ap-

paratus, by which the latch of a bucket may be thrown out, and bucket allowed to turn over. Fig. 4 shows the steel crane cable connected to a heavy manila rope, passing round a pulley, which is secured to the further side of the pit, the other end of rope, to which a hook has been spliced, is connected to the ash car, and the car is being drawn into position by means of crane.

From the views shown it can be seen that a locomotive can be moved on and off the pit without in any way interfering with the removal of ashes, as the loaded buckets are drawn out under the rail, and while the loaded bucket is being hoisted, if need be, an empty one can immediately be pushed under to receive any remaining ashes, or be ready

There is also a very convenient arrangement for wetting the ashes. A pair of pipes come through the side of the pit at each end, one for steam and the other for water. Valves are placed just clear of pit wall, and beyond the valves the two pipes are joined in one, to which a length of hose is attached. When not in use, in cold weather, the water valve is shut and a slight escape of steam keeps the hose from freezing. Water can be used for wetting the ashes, or steam for thawing frozen ashpans. With the crane for hoisting the buckets, a heavy load of ashes can be put on a car and piled to any desired height. The dumpings can also be distributed over the car, and one shift only is needed to fill it from end to end, and the next car

take charge of third engine, which they coal, sand and water, and by this time the second engine has the fire cleaned, and is ready to move to turntable, and so on.

The pit we write of is 36 ft. long, to give room to work the hoe. Outside of rails it measures 27 ft., and is, therefore, bridged by one rail. The width from rail to ash car track is 15 ft. The ash buckets are 5 ft. long, and are so placed as to suit engines with long or short ashpans.

#### Organization of Shop Forces.

The very interesting paper read by Mr. M. K. Barnum before the Western Railway Club, a notice of which appeared in our columns in August, headed *Maintaining Repair Shop Machinery*, has called forth a paper from the pen of Mr. H. T. Bentley, assistant superintendent of motive power on the S. M. & St. P. The writer refers to Mr. Barnum's choice between old shops with new tools and modern shops equipped with old tools, and agrees with him that the former is the preferable state of affairs.

Mr. Bentley, however, goes further, and proposes the question as to what the choice would be between a shop with modern tools and a poor organization and old tools and a good shop organization, and in answer to this question he says he would rather have a shop with good organization even though the tools might not be exactly up to date.

In getting together a force of men to properly turn out the work of the shop, he says the first consideration is to pick a man for the head who can be implicitly relied upon to carry out the instructions given to him, yet who shall have sufficient initiative to see where delay and friction occur and apply the remedy. Such a man should have a firm disposition and be at all times prepared to meet emergencies, and incidentally it will increase the value of the shop head if he has no relatives or friends working under him. This man must be an organizer in the true sense of the word, and every move he makes must be in the direction of increasing the shop output and decreasing the cost.

The writer expressed himself as not in favor of frills in any form, but he believed that it was poor economy to half do a job even if more expense were incurred in getting to it in the right way. When an engine comes into a railroad shop it should be the duty of one or more men to inspect it, and immediately order all the new material required. In stripping an engine each part should be plainly marked so that when wanted it could be easily found, and in this connection the storage of parts that need no repair is worthy of

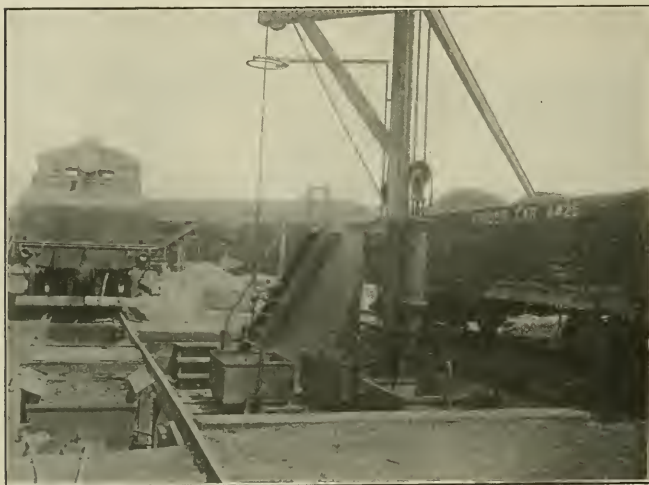

FIG. 2. GENERAL VIEW OF ASHPIT WITH ASH CAR IN POSITION.

for another engine. There are four buckets in the pit, two for each end of the ashpan. They each hold 1,500 lbs. of ashes, and have smoke box netting in the bottom to let the water run out, but prevent large cinders from blocking the drain.

The tracks upon which the buckets move are made of common iron piping, and steam passes through them in cold weather, keeping the oil from freezing on wheels of buckets, and also keeping the pit free of snow and ice in the winter time. At each end of the pit extra openings can be seen under the rails for the men to get under the engine to take the ashes from each end of the ashpan, they thus avoid the danger of crawling between the wheels. When the men are in position at each end of a pan, the buckets stand immediately in front of them, and, as the ash hoes are kept at each end of the pit between the rails, they can be drawn forward when needed.

can then be drawn into position by crane.

Two of these pits have been in operation, one at McAdam, N. B., and the other at Brownville, Me., for over two years, and have given perfect satisfaction during two of the hardest winters experienced for many years. The cost of labor for loading ashes on to cars has been 1 cent per ton. The average time taken to draw buckets from under engine, dump ashes on car, and replace bucket under engine is three minutes. With ordinary business, one man on each shift has hoisted the ashes, hoed out one end of ashpan, placed the ash cars and dried the sand.

With two crews handling incoming engines, about fifty can be taken care of per day on this pit. An engine is put on the pit, after fire cleaning, she is put in the house. The next engine following is put on the pit by second crew. The first crew returning from engine house

attention as such material is often lost through careless placing and handling of it when it is taken from an engine.

Classification of repairs also is important and each piece of work and, in-

Mr. Bentley touched on the necessity of having material on hand to keep the machines running and also a sufficient number of tools properly sharpened and dressed, always available. A shop tele-

Shop organization when in good condition is epitomized as follows: A good man at the head of the shop, good foremen under him, education of foremen and men, proper control of men by foremen, punctuality, orderliness, system, harmony, prompt movement of material to and from the various departments, a good system of handling tools, the use of templates and jigs wherever possible, absolutely fair treatment of foremen and men.



FIG. 3. ASH BUCKET OVER CAR READY FOR DUMPING.

deed, each engine, should have a schedule of time so that all concerned may labor to keep things moving on time. Improving tools and methods of doing work follows necessarily on the constant attention to schedule for all operations.

The head of the shop should have under him competent foremen, capable of handling men with consideration, firmness and fair dealing. A plan advised by Mr. Bentley was to hold weekly meetings of foremen in which a brief review of the work done might be had and discussion of the plan of campaign for work ahead. In these meetings existing conditions can be explained and improvements suggested. In this way the shop head can quickly get in touch with details which might otherwise escape him, and what is very helpful to his subordinates, he can tell them what he wants and what results he expects. The head who is wise will listen to suggestions and deal with them on their merits, avoiding the fatal course of making light or ridiculing any idea which may be expressed at the meeting. The superintendent of motive power who visits his shop and gets to know his foremen can get better results and have the men feel more kindly toward him than one who does his visiting over a long-distance telephone. A word of encouragement from him will often bring out latent ideas that might otherwise have lain dormant.

phone system will also aid in getting out work. The placing of machines so that the minimum amount of handling material takes place is important. Labor saving devices are good when not carried to extremes. "Put up an air or



FIG. 4. ASHPIT CRANE MOVING ASH CAR INTO POSITION.

electric hoist where it will save delay," he says, "but don't put up anything that will cause a man to wait until some one else is finished with it."

#### Burning Natural Gas.

A paper was presented to the meeting of the American Society of Mechanical Engineers by Mr. J. M. Whitham on Natural Gas Under Steam Boilers, in which some unexpected statements were made. He said that records of tests were made by burner people that were wholly impossible.

Tests he had made show that it is not possible to get better efficiency with natural gas than with coal.

There is but little advantage possessed by one burner over another.

As good economy is made with a blue as with a white or straw flame, and no better.

Greater capacity may be made with a straw-white than with a blue flame.

An efficiency as high as from 72 to 75 per cent. in the use of gas is seldom obtained under the most expert conditions.

The "air for dilution" is greater with gas than with coal, so that possible coal efficiencies are impossible with gas.

Don't expect in good commercial practice to get a boiler horse power on less than from 43 to 45 cu. ft. of natural gas. the same being referred to 60 de-

grees Fahr. and 4 ozs. pressure above a barometer of 29.92 ins.

Fuel costs are the same under best conditions with natural gas at 10 cents per 1,000 cu. ft. and semi-bituminous coal at \$2.87 per 2,240 lbs.

This is based on 3.5 lbs. of wet coal being used per boiler horse power per hour, or 45 cu. ft. of natural gas.

Expressed otherwise, a long ton of semi-bituminous coal is the equivalent of 28,700 cu. ft. of natural gas; while a short ton of such coal is the commercial equivalent of 25,625 cu. ft.

As compared with hand firing with coal in a plant of 1,500 boiler horse power output, coal being \$2.00 per 2,240 lbs.—considering labor saving by the use of gas—natural gas should sell for about 10 cents per 1,000 cu. ft.

#### Lackawanna Matters.

The recent loss occasioned by the great fire which destroyed the extensive buildings at the terminus of the Delaware, Lackawanna & Western Railroad, at Hoboken, N. J., is being rapidly replaced by modern structures of the most substantial kind, better suited to the increasing requirements of this great popular railway. Of late years, in addition to the large interstate and transcontinental traffic, the suburban traffic, extending to more than twenty miles from New York, resembles that of the Interborough Railway of the metropolis. Nearly one hundred trains arrive in less than two hours in the morning, and an equal number depart in the evening. The new buildings when completed will amply accommodate a quarter of a million of passengers a day, and it is no idle boast to prophecy that this number will be reached in a few years.

The roundhouse immediately adjoining the depot is one of the largest in America. With a 70 ft. turning table and accommodation for nearly 50 locomotives, it is completely equipped with every modern improvement. If all roundhouses were similarly fitted up the work in them during winter would not be such a test of human endurance as it is. With steam heat and folding doors, there is an atmosphere of everlasting summer about the place. With a storeroom filled with duplicates of every mechanical detail, and with the finest tools, it is comparatively easy to keep the engines in the finest condition. The heartrending experience of engine shortage never occurs. The D., L. & W. always have a few locomotives to spare. Mr. Bryant, the skilled master mechanic in charge of the roundhouse, has the fine faculty of foreseeing emergencies, while Mr. Crook, the clerk of the works, is an invaluable auxiliary in matters of detail. As a sample of the work of their locomotives, it may be stated that only one engine failure occurred during the

month of November—the breaking of an eccentric strap, and the consequent and unfortunate stopping of the engine on the center.

A feature of the works is the fine equipment for the production of acetylene, which is rapidly supplanting electricity as a lighting medium, and, in brief, the appliances at Hoboken are in every way in the front rank of railroad equipments, and with the completion of the repair shops at Kingsland, N. J., and the extensive terminal structural and mechanical facilities the New York end of the D., L. & W. will be a model of completeness that will leave nothing to be desired.

#### Effect of Merciless Competition.

When organized labor temporarily loses its head and permits worthless leaders to do unwise and infamous actions, there is a tendency to condemn labor unions as a whole without any consideration for the vast good they have done for the American people. One of the most beneficent actions performed by trades unions has been opposing the wage-reducing force of blind competition.

Ray Stannard Baker, writing in *McClure's Magazine* on the horrible condition of the sweat-shop workers of New York City under unrestrained competition of garment makers, says: "The tendency of wages in an unorganized industry is to sink to the wages of the man who will work cheapest and live poorest. A poor wage, like poor money, drives out the good. Allow Chinese labor to compete freely in the American market, and immediately only Chinese wages would be paid, and the American workman would be forced to live like a Chinese coolie or starve. On the other hand, in industries where no unions exist, there is a tendency for all employers to grade downward to compete with the most merciless taskmaster in the trade. An employer who wishes to pay good wages, to share his prosperity, to be benevolent, cannot do it because his neighbor grinds his workmen down, and in order to remain in business, the honest employer must stoop to the methods of the dishonest employer."

#### Better Than Sample Bricks.

But however effectual the sample bottle, the sample joke, and the sample shudder, I can show you a yet more excellent device. Deprecate your wares. Learn from the Tennessee innkeeper who described his establishment as "not the largest hotel in the burg; not newly furnished throughout; no free bus to trains; not the best grub the market affords; but simply clean beds and good food; 25 cents a sleep, 25 cents an cat. Toothpicks and icewater thrown in. Try

us! Pay up! And if not satisfied keep mum."

Or emulate the New Jersey husbandman who declared: "Owing to ill health, I will sell one blush raspberry cow, aged eight years. She is of undaunted courage and gives milk freely. To a man who does not fear death in any form, she would be a great boon. I would rather sell her to a non-resident of the county."

Or again, wisely imitate the New York tapster who set above his door the superscription, "Road to Hell." By thus quietly assuming that success can in no wise be scared off the premises, you shall certainly outvie your loud boasting competitors. Besides, you will deal exclusively with men of valor, which, in these soft times, is a rare enough privilege.—*Atlantic Monthly*.

#### Reliable Air Hoist.

The air hoist is one of the most convenient appliances used in up-to-date shops, and the hoist shown in our illustration is the most up to date of its kind. It is always in a self-balanced condition, the tank pressure of air being always on the lower side of the piston. To lift the load, air from above the piston is released to the atmosphere according to the speed of lift desired. To lower the load, air is by-passed from below the piston to the upper side, equalizing the pressure, and the difference in areas of the sides of the piston (caused by the diameter of the rod), plus the weight of the piston and rod, causes the piston to be positively returned. Thus, air is used one way only. This is an important feature. All the steadiness of a hydraulic lift is obtained with this hoist.

There are two sets of hand chains, one for rapid and the other for slow handling of the load. The instant either chain is released, the self-closing air-actuated valve shuts, and the load is held in place indefinitely.

The load-retaining device consists of a friction collar on the piston rod, connected to an auxiliary valve and operating upon the slightest movement of the rod to replace any leakage of air from above or below the piston, sustaining the load indefinitely without any variation and at any desired height. A check valve on the air-supply pipe provides against dropping the load if the hose connection is broken.

The hoist is made by Pedrick & Ayer, Plainfield, N. J., who are noted for the manufacture of handy shop appliances. Send for their illustrated catalogue, and tell them that we advised you to do so.

The use of perfumes is as old as civilization itself. The ancient Assyrians and Persians are known to have favored them.



# Of Personal Interest.

M. H. H. Vaughan, superintendent of motive power for lines east on the Canadian Pacific Railway, has been appointed assistant to the vice-president of the same road, with office at Montreal, succeeding Mr. W. R. Baker, who was recently appointed assistant to the president. It is understood that he will have charge of motive power and rolling stock matters, and handle fuel, stores and electrical questions. In placing Mr. Vaughan in this new position he has been elevated by the company from the position of a department officer to that of an executive official. This is certainly a new departure in motive power appointments. The mechanical department of a railway is like the public works department in a government and the creation of this new position is but another evidence of the growing appreciation of the fact by railroad presidents and the higher executive officials. Mr. Vaughan received his technical education at King's College, London, Eng-

consolidated with the Railway Supply Co. He continued in the service of the latter company as mechanical engineer and superintendent of shops until March 1, 1902, when he was appointed assistant superintendent of motive pow-

and to the King since. He has held a variety of other honorable positions. He is colonel of the 3d battalion of the Gordon Highlanders.

During a visit to London last summer the writer called on the Earl of Kintore by appointment, and was very kindly entertained. Old times were talked over, and his Lordship invited us to visit him at his country seat in Scotland, a courtesy we were not able to accept.

Mr. W. H. Wilson, who has been appointed superintendent of motive power of the Buffalo, Rochester & Pittsburgh Railway, began his railroad work in 1881. He was at the outset an apprentice in the shops of the Lehigh Valley and he worked there for several years. In 1886 he went to the Dunmore Iron & Steel Company, and after two years' work in their locomotive shops he was advanced to the position of foreman of that department of their work. Six years later he became general foreman for the same concern, and in 1900 that



LT.-COL. THE EARL OF KINTORE,  
GORDON HIGHLANDERS.

er of the Lake Shore & Michigan Southern. In February, 1904, Mr. Vaughan left the latter company to become superintendent of motive power of the Canadian Pacific Railway.

When the Earl of Kintore was Governor of South Australia he made a statement to a meeting of railway men that he had learned to fire and drive a locomotive in his youth, and enjoyed the work. The writer had the pleasure of instructing the Earl in firing and running, and found him a very apt and willing pupil. At that time he was known as Lord Inverurie, and he was a young man attending college. The firing and engine running experience was gained during holidays. His Lordship has gone through rather varied experiences since those days. He succeeded his father in 1880, and holds the titles of Sir Algernon Hawkins Thomson Keith-Falconer, P.C., G.C.M.G., LL.D., Lord Falconer of Halkerton and Lord Keith of Inverurie and Baron Kintore. He was Lord in Waiting to Queen Victoria 1835-6, Captain of the Yeomen of the Guard 1886-9, Governor and Commander-in-Chief of South Australia 1889-95, Lord in Waiting 1895-01,



W. H. WILSON.

company gave him the position of master mechanic. In 1904 he returned to the railroad field as master mechanic on the Susquehanna, Jefferson & Tioga divisions of the Erie Railroad, where he remained until offered a higher position as executive head of the motive power department of the Buffalo, Rochester & Pittsburgh.

Mr. C. S. Bricker has been appointed master mechanic of the Sheridan division of the Chicago, Burlington & Quincy, with headquarters at Sheridan, Wyo.

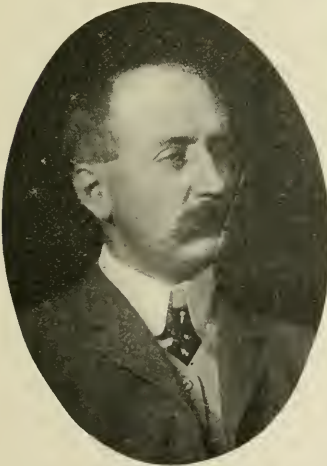

H. H. VAUGHAN.

land, and subsequently served three years as a special apprentice with Nasmith, Wilson & Co., of Patricroft, England. He came to America in 1891 and was with the Great Northern for nearly eight years as machinist, draughtsman, assistant engineer of tests and mechanical engineer. He left the Great Northern in February, 1898, to become mechanical engineer of the Philadelphia & Reading, but resigned in November of the same year to accept a position as mechanical engineer of the Q. & C. Co., of Chicago, which afterwards was

Mr. J. J. Bernet has been appointed assistant general superintendent of the Lake Shore & Michigan Southern, with headquarters at Cleveland, Ohio.

Mr. S. W. Brown has been appointed superintendent of the Eastern division of the Lake Shore & Michigan Southern, with headquarters at Buffalo, N. Y.

Mr. H. C. Woolbridge, formerly general foreman of the Delaware, Lackawanna & Western, has been appointed master mechanic of the Buffalo and Rochester divisions of the Buffalo, Rochester & Pittsburgh, with office at East Salamanca, N. Y.

Mr. H. A. Worcester has been appointed general superintendent of the Michigan Central, with headquarters at Detroit, Mich.

Mr. E. W. Fitt has been appointed master mechanic of the Alliance and Sterling divisions of the Chicago, Burlington & Quincy, with headquarters at Alliance, Nebraska, vice Mr. F. J. Kraemer, assigned to other duties, as the position of assistant superintendent of motive power has been abolished.

Mr. A. B. Ford, formerly traveling engineer on the Montana Central, has been appointed master mechanic of the Minot division of the Great Northern, with headquarters at Minot, N. D.

Mr. J. E. Chisholm has been appointed general master mechanic of the Chicago Great Western, with headquarters at Oelwein, Ia.

Mr. R. L. Wyman, heretofore foreman on the Delaware, Lackawanna & Western, at Binghamton, N. Y., has been appointed general foreman on the same road, with headquarters at Utica, N. Y., vice R. P. Schilling, resigned.

Mr. W. O. Smith has been appointed foreman of the Delaware, Lackawanna & Western, with headquarters at Binghamton, N. Y., vice Mr. Wyman, promoted.

Mr. C. T. Walters, master mechanic on the Great Northern at Minot, N. D., has been transferred to the Montana division of the same road, with headquarters at Havre, Mont.

Mr. F. M. Fryburg, formerly master mechanic on the Great Northern at Havre, Mont., has been appointed master mechanic of the Montana Central, with headquarters at Great Falls, Mont.

Mr. J. E. Gould, at one time general foreman of the Panhandle shops at Dennison, O., has been appointed superintendent of motive power of the Norfolk & Southern, with headquarters at Berkley, Va.

Mr. T. A. Sweeney, formerly division superintendent of the Cincinnati, Hamilton & Dayton, at Wellston, O., has

been appointed superintendent of the main line from Toledo to Cincinnati, with headquarters at Cincinnati, O.

Mr. George H. Daniels, the well known general passenger agent of the New York Central, has been recently placed in charge of a new department, which has been created by the allied railroad interests, comprehended under the title of the New York Central Lines. Mr. Daniels began his railroad career in 1872, when he was appointed general passenger agent of the Chicago & Pacific Railroad, a small road about 40 miles in length. In 1880 he became general ticket agent of the Wabash, St. Louis & Pacific. Two years later he was appointed commissioner of the Colorado Railroad Association, and to this was added the Utah Railroad Association and then in rapid succession he held various traffic association posi-



GEO. H. DANIELS.

tions until, in the early part of 1889, he was appointed general passenger agent of the N. Y. C., a position which he has held with honor and ability for nearly 17 years. In creating this department, the New York Central Lines have made a new departure, and in appointing Mr. Daniels as the first chief of that department the companies have secured the services of a past master in the art of advertising. This great aggregation of railroad interests is the first to inaugurate an advertising department which covers all the railways in their system, and though the far-reaching consequences of such an innovation may not at first be appreciated, it nevertheless emphasizes the value of advertising generally, and forces the conclusion that the management of these lines believe in the efficacy of railway advertising in particular. Some idea of the importance of this new depart-

ment can be had when it is understood that Mr. Daniels will control the general advertising in America and in foreign countries of the New York Central, the Boston & Albany, the Lake Shore & Michigan Southern, the Michigan Central, the Cleveland, Cincinnati, Chicago & St. Louis, the Rutland, and the Lake Erie & Western railways and their leased lines, having their western terminals at Chicago, St. Louis and Cincinnati, and their eastern terminals at New York, Boston and Montreal, and embracing more than twelve thousand miles of railway. The new chief of this department has been for many years a firm believer in newspaper and magazine advertising, and in an address delivered before the New York State Press Association a few years ago, he made the point that the railroad is the advance agent of commerce, and that railway advertising had been of immense value to American manufacturers in calling the attention of the whole world to the excellent work done by our inventors and mechanics. It is the hope of Mr. Daniels' many friends that he will have the fullest opportunities for many years to come of carrying out the broad-minded policy, in matters connected with his department, which has made his name so well known to railroad men and to the traveling public.

Mr. James C. Dennis, well known in the pneumatic tool business, has entered the service of the Independent Pneumatic Tool Company as traveling salesman. His headquarters are in New York.

Mr. Richard D. Hurley has been appointed manager of the office recently opened in Pittsburgh by the Independent Pneumatic Tool Company of Chicago.

Mr. Charles A. Olson, who for several years has been superintendent of the flange fitting department of Crane Co., Chicago, has been promoted to the newly created position of general superintendent of that company. Mr. Olson was formerly superintendent of the St. Petersburg (Russia) plant of the Societe Anonyme Westinghouse.

Mr. J. B. Michael, master mechanic of the Knoxville division of the Southern Railway, has had his jurisdiction extended to cover the Nashville division of the same road.

Mr. W. C. Ennis, heretofore master mechanic of the Susquehanna and Pennsylvania division of the Delaware & Hudson, has been appointed superintendent of the car shops and repair work, with headquarters at Carbondale.

Mr. George Edmonds, mechanical engineer of the Delaware & Hudson, has been appointed master mechanic of the Susquehanna and Pennsylvania division

of the same road, with office at Oneonta, N. Y., vice Mr. W. C. Ennis, promoted.

Mr. Samuel P. Pryor has been appointed purchasing agent for the Missouri Pacific-Iron Mountain System, with office in St. Louis. He is a brother of Mr. E. B. Pryor, fourth vice-president of the Wabash. Mr. S. P. Pryor's appointment does not affect Mr. W. G. Nixon, who retains his title as purchasing agent of the Gould lines.

Mr. W. J. Underwood, the newly appointed general manager of the Chicago, Milwaukee & St. Paul Railway, has done all his railroad work on that road, and has made his way steadily up from unpretentious beginnings. He entered the service of the C. M. & St. P. as a brakeman and went through the hard apprenticeship which that form of railroad work entails. In due time he became a freight conductor, and was later given the position of superintendent of the Sioux City and Dakota division; several years later saw him superintendent of the Dubuque division and again as superintendent of the River division of the same railroad. With the practical experience gained on the road and as an operative official, he was subsequently selected for the position of assistant general superintendent, and later he became general superintendent of the entire system. He was again promoted to be the assistant general manager and last month he was advanced to the responsible position of general manager. His career all through has been marked by hard work, ability and an untiring devotion to business. He is a man of robust health, six feet high, in the prime of life and has therefore plenty of good work ahead of him. He is not a society or club man in any sense, but like many others who, while achieving a marked success in their chosen callings, have also the faculty of taking pleasure in accomplishing as a pastime what others do seriously. Such men work hard and play hard, and one form of Mr. Underwood's recreation has made him a successful breeder and lover of fine horses, being now an acknowledged authority on the subject. Outside the railway he is a scientific farmer, and it has often been said of him that a railroad life deprived the agricultural interests of the country of a strenuous tiller of the soil. In partial rebuttal of this humorous charge, it may be said that he has a fine farm near St. Paul, to which he gives much personal attention. Faltering is not one of Mr. Underwood's characteristics, and in this work as well as in the more exacting duties of the general manager it may be truthfully said that having put his hand to the plow he has not looked back. He is descended from a family

which took part in the affairs of this country in the days of stress and strain, his great-grandfather having been a colonel in the Colonial and Revolutionary Wars. His father was a Baptist minister prominent in his day and denomination. Those who know the general manager of the St. Paul road describe him aptly as a man level-headed under all conditions and circumstances.

Mr. Arthur Kempler has been appointed general superintendent of transportation of the Delaware & Hudson, with headquarters at Albany, N. Y.

Mr. George Tilton has been appointed superintendent of shops of the Mexican Central, with headquarters at Aguascalientes, Mex., vice Mr. H. V. Ridgeway, resigned.

Mr. Horace Baker has been appointed general superintendent of the Southern district of the St. Louis, Iron Mountain & Southern, with headquarters at Little Rock, Ark., vice Mr. W. T. Tyler, resigned.

Mr. G. H. Stapp has been appointed superintendent of the Joplin division of the Central district of the St. Louis, Iron Mountain & Southern, with headquarters at Nevada, Mo.

Mr. J. M. Walsh has been appointed superintendent of the Northern Kansas division of the St. Louis, Iron Mountain & Southern, with headquarters at Atchison, Kan.

Mr. H. E. Martin has been appointed general superintendent of the Little Rock & Hot Springs Western, with headquarters at Hot Springs, Ark.

Mr. J. Russell has been appointed superintendent of the Omaha division of the Northern district of the St. Louis, Iron Mountain & Southern, with headquarters at Omaha, Neb.

Mr. T. Fraser has been appointed master mechanic of the Algoma Central & Hudson Bay Railway, succeeding C. E. Slayton, resigned.

Mr. C. J. Larimer, formerly trainmaster of the International & Great Northern, has been appointed division superintendent of the same road, with headquarters at Mart, Tex.

Mr. J. H. Young, general superintendent of the Colorado & Southern, has been appointed general manager, with office at Denver, Colo.

Mr. J. H. Bannerman, formerly superintendent of motive power of the Tennessee Central, is now connected with the W. J. Oliver Mfg. Company, of Knoxville, Tenn., as mechanical superintendent.

Mr. James A. McCrea has been appointed general superintendent of the Long Island Railroad, with headquarters at Long Island City, N. Y.

Mr. F. J. Egan has been appointed superintendent of the Nashville division of the Southern, with headquarters at Nashville, Tenn.

Mr. J. B. Elliott has been appointed general master mechanic, lines east of Fort William, on the Canadian Pacific Railway, with office at Augus Shops, Montreal.

Mr. F. E. Kennedy has been appointed master mechanic of the McCook division of the Chicago, Burlington & Quincy, with headquarters at McCook, Neb., vice Mr. R. B. Archibald, resigned.

#### Obituary.

We regret to announce the death of Miss C. A. Baker, daughter of the late William C. Baker. On the death of Mr. Baker, five years ago, Miss Baker took up the management of the Baker Car Heater business, which she conducted most successfully until her death, which was exceedingly sudden and unexpected. Miss Baker was a remarkably able business woman, but she was very retiring in her habits, which limited her circle of acquaintance among railroad people. Miss Baker was very charitable and many poor people will suffer through her premature death.

#### Old Things and New.

"Old things made new" is a common expression, but not a very accurate one, for if a thing is old, it must remain old and even grow more so. If, however, you say you can make an old thing look like new or look as it did when new, that is a different kind of statement and one which has the element of truth in it. The only thing which stands in the way of making the second statement a reality is how to do it. This depends on what you want to do. If you want to make a house look like new you paint it, and if you want to make a dimmed headlight reflector or a piece of brass look like new, you polish them up. When you paint a house you lay something on and leave it there, but when you scour a piece of brass work you put something on, but you don't leave it there. For instance, when dealing with brass work or, indeed, any metal surface, you can put on it a substance like U. S. metal polish paste, and after a few good rubs the metal polish, and the grimy or staining material comes off, too, and the whole thing looks as it did when new and it can be kept in that condition indefinitely. We know a man at 205 East Washington street, Indianapolis, Ind., who believes in making old things look like new. He has had experience in the matter and he makes the metal polish. Write to Mr. G. W. Hoffman and ask him about it. His New York address is 3 Park Row.

## Tire Turning Extraordinary.

BY GEORGE S. HODGINS.

Eight revolutions of the lathe and a half-inch roughing cut has been driven across the tread of a pair of locomotive tires on a half-inch feed. That was the program at an informal but very real test of the capabilities of a new Niles-Bement-Pond driving wheel lathe carried out at the West Albany shops of the New York Central, on Monday and Tuesday before Christmas. The test consisted, roughly speaking, of turning the tires of 15 pairs of driving wheels in 15 hours, and in order to do that the decks had been cleared for action, and the way the lathe tools "hogged" off the metal was a sight to see.

The machine is one of the latest and heaviest type of this class of lathes,

tance between faceplates is 9 ft. The tool posts are short and wide like a fat man with no neck. They squat down close to their bases and cannot spring or jar. The lathe has heavily toothed internal driving gear which measures 8 ins. across the face. An independent motor traverses the movable head. Mr. R. T. Shea, the general inspector of tools and machinery for the New York Central lines, is very largely responsible for the design of this lathe, and the output of the machine on this occasion was fully equal to the most sanguine expectations of the New York Central officials. The machine is driven by a 40 h.p. motor guaranteed for 50 per cent. overload, and 58 to 60 h.p. were actually required to do the work during the 15 hour test.

Taking one tire as an example, it was completed and made ready to put under an engine in about 21 revolutions of the lathe. Counting in this manner, there were 8 required for the roughing cut on the tread, 3 on the top of the flange, one on each side, (2) of flange to cut off the square corners of the top; making 13 revolutions for roughing cuts. Then there were 2 revolutions for scraping and sizing the tread, 2 for cutting outer bevel and chamfering outside corners of tread, and two each side (4) for shaping the flange, making 21 revolutions in all. All the roughing cuts were made with one setting, and four other settings covered the finishing cuts, making in all 5-tool settings:

Wheels with diameters varying from 50 to 72 ins. were turned up at an aver-

TIME TEST DRIVING WHEEL WORK, WEST ALBANY SHOPS, NEW YORK CENTRAL.

Date.	Kind of tool.	Size of tool.	Tire: Diam. and kind.	Speed. Ft. per minute.	Feed per Revolution.	Depth of cut.	Distance traveled.	Condition of tool.	Putting wheel and fasten.	Cut-ting.	Taking out wheel.	Total change wheel.	Total.
12-13	Rex-A	3 ins. x 1½ ins.	50 in. diam. Midvale	12 ft. 9 ins.	15/32 in.	5/16 in.	5½ ins.	Good					
12-13	Musket	3 ins. x 1½ ins.	50 in. diam. Midvale	12 ft. 9 ins.	15/32 in.	¾ in.	3 ins.	End burnt off	7 min.	39 min.	3 min.	10 min.	49 min.
12-13	Rex-A	3 ins. x 1½ ins.	50 in. diam. Midvale	12 ft. 9 ins.	15/32 in.	¾ in.	2½ ins.	Good					
12-13	Rex-A	3 ins. x 1½ ins.	50 in. diam. Midvale	12 ft. 9 ins.	15/32 in.	¾ in.	7/16 in.	Good	7 min.	40 min.	3 min.	10 min.	50 min.
12-13	Musket	3 ins. x 1½ ins.	50 in. diam. Midvale	12 ft. 9 ins.	15/32 in.	¾ in.	7/16 in.	Good					
12-13	Rex-A	3 ins. x 1½ ins.	50 in. diam. Midvale	12 ft. 9 ins.	15/32 in.	¾ in.	5/16 in.	Good	7 min.	41 min.	3 min.	10 min.	51 min.
12-13	Rex-A	3 ins. x 1½ ins.	50 in. diam. Midvale	12 ft. 9 ins.	15/32 in.	¾ in.	5/16 in.	Good					
12-13	Musket	3 ins. x 1½ ins.	50 in. diam. Midvale	12 ft. 9 ins.	15/32 in.	¾ in.	1½ ins.	End burnt off	8 min.	44 min.	4 min.	12 min.	56 min.
12-13	Rex-A	3 ins. x 1½ ins.	57 in. diam. Midvale	12 ft. 9 ins.	15/32 in.	¾ in.	5/8 ins.	Good					
12-13	Rex-A	3 ins. x 1½ ins.	57 in. diam. Midvale	12 ft. 9 ins.	15/32 in.	¾ in.	4½ ins.	Good					
12-13	Rex-A	3 ins. x 1½ ins.	57 in. diam. Midvale	12 ft. 9 ins.	15/32 in.	7/16 in.	5½ ins.	Good	7 min.	42 min.	3 min.	10 min.	52 min.
12-14	Rex-A	3 ins. x 1½ ins.	57 in. diam. Midvale	12 ft. 9 ins.	15/32 in.	7/16 in.	5½ ins.	Good					
12-19	Midvale	3 ins. x 2 ins.	57 in. diam. Midvale	12 ft. 9 ins.	15/32 in.	7/16 in.	15/32 in.	Point burnt off	6 min.	45 min.	2 min.	8 min.	53 min.
12-19	Rex-A	3 ins. x 1½ ins.	57 in. diam. Midvale	12 ft. 9 ins.	15/32 in.	5/8 in.	5/8 ins.	Good					
12-19	Rex-A	3 ins. x 1½ ins.	57 in. diam. Midvale	12 ft. 9 ins.	15/32 in.	7/16 in.	5 9/32 ins.	Good	7 min.	46 min.	2 min.	9 min.	55 min.
12-19	Rex-A	3 ins. x 1½ ins.	57 in. diam. Midvale	12 ft. 9 ins.	15/32 in.	7/16 in.	5½ ins.	Point burnt off					
12-19	Rex-A	3 ins. x 1½ ins.	57 in. diam. Midvale	12 ft. 9 ins.	15/32 in.	7/16 in.	3½ ins.	Good					
12-19	Rex-A	3 ins. x 1½ ins.	57 in. diam. Midvale	12 ft. 6 ins.	15/32 in.	9/16 in.	5½ ins.	Good	8 min.	44 min.	2 min.	10 min.	54 min.
12-19	Rex-A	3 ins. x 1½ ins.	57 in. diam. Midvale	12 ft. 6 ins.	15/32 in.	9/16 in.	5½ ins.	Good					
12-19	Rex-A	3 ins. x 1½ ins.	57 in. diam. Midvale	11 ft. 8 ins.	15/32 in.	¾ in.	5½ ins.	Good	7 min.	43 min.	2 min.	9 min.	52 min.
12-19	Rex-A	3 ins. x 1½ ins.	57 in. diam. Midvale	12 ft. 3 ins.	15/32 in.	7/16 in.	5½ ins.	Good					
12-19	Rex-A	3 ins. x 1½ ins.	57 in. diam. Midvale	12 ft. 3 ins.	15/32 in.	7/16 in.	3½ ins.	Point broken off	6 min.	42 min.	2 min.	8 min.	50 min.
12-19	Rex-A	3 ins. x 1½ ins.	57 in. diam. Midvale	12 ft. 3 ins.	15/32 in.	7/16 in.	5½ ins.	Good					
12-19	Rex-A	3 ins. x 1½ ins.	57 in. diam. Midvale	10 ft. 8 ins.	15/32 in.	¾ in.	5½ ins.	Good	6 min.	50 min.	2 min.	8 min.	58 min.
12-19	Rex-A	3 ins. x 1½ ins.	57 in. diam. Midvale	10 ft. 8 ins.	15/32 in.	¾ in.	5½ ins.	Point broken off					
12-19	Rex-A	3 ins. x 1½ ins.	57 in. diam. Midvale	11 ft. 9 ins.	15/32 in.	7/16 in.	5½ ins.	Good	6 min.	52 min.	2 min.	8 min.	60 min.
12-19	Rex-A	3 ins. x 1½ ins.	57 in. diam. Midvale	11 ft. 8 ins.	15/32 in.	7/16 in.	5½ ins.	Good					
12-19	Rex-A	3 ins. x 1½ ins.	57 in. diam. Midvale	8 ft. 6 ins.	15/32 in.	¾ in.	1 in.	Point burnt off					
12-19	Rex-A	3 ins. x 1½ ins.	57 in. diam. Midvale	8 ft. 6 ins.	15/32 in.	5/16 in.	2½ ins.	Good					
12-19	Rex-A	3 ins. x 1½ ins.	57 in. diam. Midvale	11 ft.	15/32 in.	¾ in.	5½ ins.	Good	7 min.	47 min.	2 min.	9 min.	56 min.
12-19	Rex-A	3 ins. x 1½ ins.	57 in. diam. Midvale	11 ft.	15/32 in.	¾ in.	5½ ins.	Good					
12-19	Rex-A	3 ins. x 1½ ins.	72 in. diam. Midvale	14 ft.	13/32 in.	¾ in.	5½ ins.	Good	8 min.	46 min.	2 min.	10 min.	56 min.
12-19	Rex-A	3 ins. x 1½ ins.	72 in. diam. Midvale	14 ft.	13/32 in.	¾ in.	5½ ins.	Good					
12-19	Musket	3 ins. x 1½ ins.	72 in. diam. Midvale	14 ft.	13/32 in.	5/16 in.	5½ ins.	Good	7 min.	43 min.	2 min.	9 min.	52 min.
12-19	Musket	3 ins. x 1½ ins.	72 in. diam. Midvale	14 ft.	13/32 in.	7/16 in.	5½ ins.	Good					

15 pairs turned in 501 minutes; average 53½ minutes.

664 min. 140 min. 804 min.

and weighs about 120,000 lbs. The faceplates have recesses to receive the crank pins and this permits of short, strong centers being used. Each faceplate has four steel toothed shoes driven tightly against the wheel rims by stout keys, and these constitute a powerful friction grip which carries the wheel round with the faceplate under the heaviest cuts, and the clamping which is also done prevents any vibration, and practically makes faceplate and wheel one piece for the time being. These grips were invented by Mr. D. H. Teas, who is connected with the makers of the lathe, and who was present during the test. The lathe itself is an exceptionally heavy machine, with every part made to stand up to very hard work. It swings 92 ins. and the maximum dis-

We give above the tabulated result of this test, which is vouched for by Mr. L. H. Raymond, shop superintendent at West Albany, and also by Mr. Shea, the time of each operation and also the speeds and cuts having been taken by a special timekeeper, who watched and recorded every move. The cutting speed varied between narrow limits, the lowest being 8 ft. 6 ins. per min. and the highest 14 ft., while 12 ft. 9 ins. was generally maintained. The tools were made of tungsten steel, air cooled, 1½x3 ins. in section and the chips which curled up smoking hot from the half-inch cuts actually sparked as their ragged edges crackled and broke away. Each time a roughing tool was used it was laid aside by the operator and a new one placed ready for the next tire.

age of 53½ minutes per pair, and this was done in two continuous performances of five and ten hours, respectively. The total weight of metal removed in the 15 hours was about 3,000 lbs. With this thoroughly practical wheel lathe performance as a basis, it is easy to see that taken in conjunction with the drop pit, the worn tire bugaboo can be given a very severe shock if not driven out of the shop altogether, and motive power men will not find it so necessary to wait for other parts of an engine to wear out or break down before it is worth while to take an engine in and turn the tires. Viewed simply as a matter of time this lathe makes the work look almost as short as a roundhouse job.

Although the test was a very important one, it was conducted quietly but

in a thoroughly businesslike way. In addition to those already mentioned, Mr. G. H. Haselton, division superintendent of motive power of the N. Y. C., was present during the test. Messrs. J. E. Epler and W. E. Hubbard, piecework inspectors for the road, were there, and Mr. John Parsons, from the wheel lathes of the company's Depew shops. The man behind the gun at the West Albany shops was Mr. Frank J. Baumis, and his phenomenal record on this lathe

of special form. This plate is held in place by one bolt and a tongue and groove across the head. The outside and the inside flange finishers and the roughing tools are shown in Fig. 3. Altogether it may be said that the lathe itself, the cutting tools and the whole method of operation have been the subject of much thought and of very careful work, and the result reflects great credit on all concerned. There has been considerable expense incurred to bring things to

wire, standard mechanical specifications, storage battery installation, etc. Any one desiring a copy should apply to this office for one.

**Not a Wedding but a Boring.**

A short time ago we received what by the look of the envelope appeared to be a wedding notice. With words

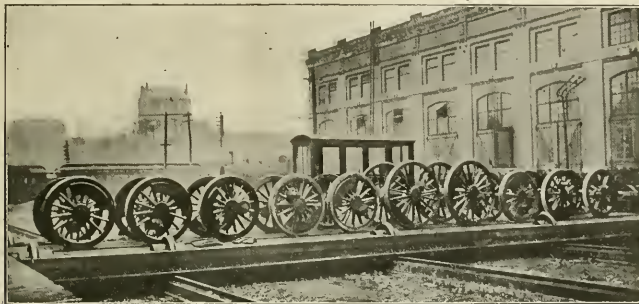

THE DAY'S WORK FOR THE WHEEL LATHE.

earned him a special \$100 bonus for the pair-per-hour speed for a day and a half, offered by the general tool and machinery inspector of the road. The outsiders who witnessed the test were Mr. J. G. Thompson, foreman of the erecting shop of the D. & H., and a representative of RAILWAY AND LOCOMOTIVE ENGINEERING.

The roughing tools used were of the usual pattern, while the finishing tools were built up as shown in the sketches. The finishing tool for tread scraping and sizing is shown in Fig. 1, and consists of a 1½x3 in. shank with a 3 in.

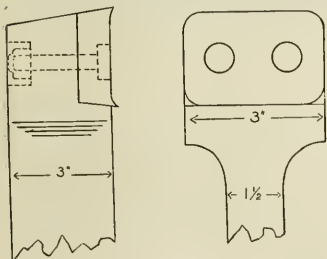

FIG. 1. TREAD FINISHING TOOL.

face. The upper surface of the head is cut square away and bolted to, and fitting close to the shoulder is a plate of 3 in. tungsten high speed steel held in place by two bolts. This plate has two cutting edges, only one of which is used at a time. The tool for chamfering the outer corner of the tread and finishing the outer bevel, Fig. 2, is similar in general form to that of Fig. 1. It has, however, only one cutting edge and it is

a successful conclusion but in this case, at least, the end has fully justified the means.

**Signal Association Proceedings.**

We are pleased to announce that the Proceedings for 1905 of the Railway Signal Association was issued last De-

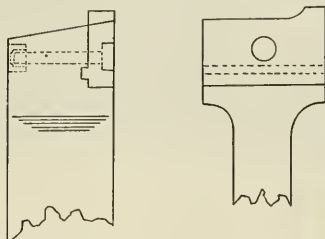

FIG. 2. TREAD FINISHING AND CHAMFERING TOOL.

ember. This publication is full of interesting literature on matters pertaining to signals. The various committee reports and papers written during the

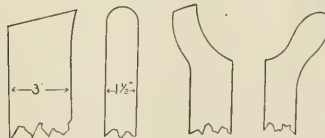
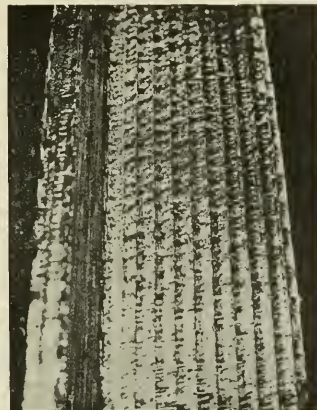

FIG. 3. ROUGHING, AND FLANGE FINISHING TOOLS.

year have been reprinted, together with all the discussions relating thereto. These discussions covered a number of topics, such as lights, rubber covered



TIRE AFTER ROUGHING CUT.

of congratulation for the happy man on our lips, we opened the neat little missive and found that it was more like a "boring," which is the word coined by a little five year old to explain how he came to have a new sister one day last month.

The announcement was, in fact, a brief statement that the Chicago & Northwestern, the Union Pacific and the Salt Lake Route had arranged for a new

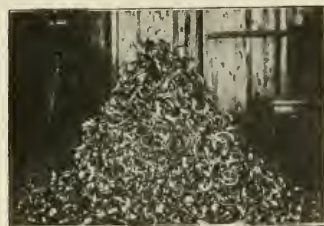

OVER A TON OF STEEL CHIPS.

train over their lines called the Los Angeles Limited. The limited runs daily, and the cars are lighted by electricity. The train consists of standard and tourist sleeping cars, an observation car with buffet, smoking and library apartments and a diner with meals à la carte. The companies concerned have arranged for news bulletins from all parts of the world to be telegraphed to

this train twice a day. Our congratulations intended for the happy man now go to the happy travelers on this train.

#### Wabash Passenger 4-6-0.

Some time ago the Wabash Railroad secured from the Baldwin Locomotive Works a number of fast passenger engines similar to the one shown in our illustration. The engine is a simple one with piston valves. The cylinders are 21x28 ins. and the drivers are 73 ins. in diameter. The equal spacing of the driving wheels gives the engine a good appearance, though it does not add anything to its ability to haul cars or make time. The main drivers are not flanged and all the driving tires are supplied with retaining rings.

water space, front, 5 ins.; sides, 4½ ins.; back, 5 ins. Driving wheels—Journals, 10 ins. x 12 ins. Engine truck wheels—Diameter, 36 ins.; journals, 6 ins. x 12 ins. Wheel base—Rigid, 14 ft. 8 ins.; total engine, 25 ft. 8 ins.

Tender—Wheels, diameter, 36 ins.; journals, 5½ ins. x 10 ins.

#### Steel Flat for Canal Work.

The Isthmian Car Commission have been buying large quantities of material and equipment for the work on the Panama Canal, and have recently received from the Standard Steel Car Company, of Pittsburgh, a large number of steel flat cars. Through the courtesy of Mr. J. M. Hansen, president of the company, we are able to place some information concerning these cars before our readers.

plates. The center sills are formed of angles and plates. The plates following the line of the truss channels of the outside sills, and being 26 ins. deep for a length of about 6 ft. 6 ins. at the center of the car. The stiffening angles on the lower edge of this plate are 4x4 ins., the outer one being ¾ in. thick and the inner one ½ in. A plate along the top of the center sills makes the construction practically a box girder open on the under side. The body bolster construction is solid and compact. It is made of angles and flanged web plates. There are two heavy plates, laid one on top and the other bottom, which are widest where they are secured to the center sills. The end sills are 10 in. channels, 15 lbs. to the foot, and the cor-

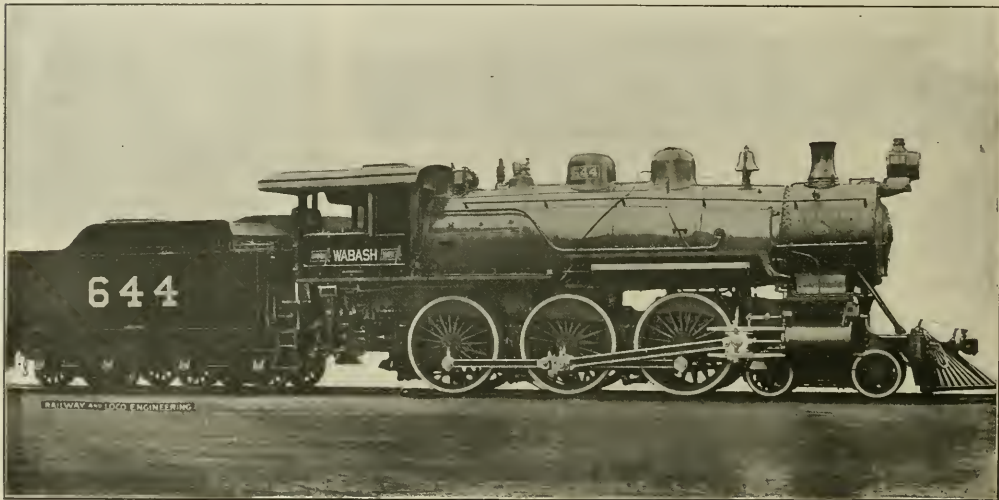

PASSENGER TEN-WHEEL ENGINE FOR THE BANNER ROUTE.

J. B. Barnes, Superintendent Locomotive and Car Department.

Baldwin Locomotive Works, Builders.

The boiler is of the wagon top type with the gusset well forward. The smallest boiler course is 68 ins. and from flue sheet to flue sheet it measures 15 ft. 5½ ins. The fire box is 120 ins. long by 40¼ ins. wide, and at the front it has a depth of 74¾ ins. and at the back it is 65¾ ins. deep. The tubes are 362 in number, of standard 2-in. diameter, and give a heating surface of 2,620.8 sq. ft. The fire box gives 175 sq. ft., and the total heating surface is therefore 2,795.8 sq. ft. The grate area amounts to 33½ sq. ft.

The tank is the ordinary U-shaped pattern and can hold 6,000 U. S. gallons of water. A few of the principal dimensions of this engine are as follows:

Boiler—Diameter, 68 ins.; thickness of sheets, 11/16 in., ¾ in. and ¾ in.; working pressure, 220 lbs.; fuel, soft coal; staying, radial. Fire box—Thickness of sheets, sides, ¾ in.; back, ¾ in.; crown, ¾ in.; tub, ¼ in.;

The car, which weighs 33,000 lbs., is 35 ft. long and is made of structural steel shapes and plates, with wooden floor. The width over the side sills is 9 ft. and the total over the side pockets is 10 ft. 1 in. The car has a capacity of 100,000 lbs., and it will sustain this weight when two-thirds of the load is concentrated at the center. The car was designed by Mr. Cornelius Vanderbilt.

The sills are four in number, the two outside ones being made of steel channels which are practically trussed by a 6 in. channel weighing 10½ lbs. to the foot. What would correspond to the queen posts of this truss system are angles placed about 3 ft. 3 ins. from the center of the car, and they, the truss channel and the outside sill, are all tied together at this point by a 10 in. channel, 15 lbs. to the foot, passing from outside to outside through the center sill

ners are diagonally braced with 5 in. channels, 6 lbs. to the foot.

The floor of the car is wood, which can be easily renewed as required. At one end of each car there is an apron plate the full width, and this plate covers the space between the cars, and as it is on the floor level, permits a string of these ballast cars to be ploughed off. The brake mast is on a pivot and swings down clear into a horizontal position below the apron plate.

The car is a simply and strongly built one, and should be capable of standing all the hard work that will be expected of it in Panama. A few of the principal dimensions are given below:

Gauge of track.....	5 ft. 0 ins.
Length over end sills.....	35 ft. 0 ins.
Width of car over side pockets.....	10 ft. 1 in.
Width of car over side sills.....	9 ft. 0 ins.
Width over floor.....	9 ft. 1 in.
Height from top of rail to top of floor .....	3 ft. 9¾ ins.

Neither theory nor practice has ever yet produced the lubricant that can do the work or take the place of

# DIXON'S TICONDEROGA FLAKE GRAPHITE

Just read, for example, what a Master Mechanic writes us :

Gentlemen :—

*We have made a thorough test of your grease in driving boxes and have been able to reduce our hot boxes to a minimum, since using the same. We have a locomotive that is equipped with hammered iron axles, which are full of seams and small cracks, and have been unable to run this engine more than one hundred miles without repacking boxes. Since using Dixon's Graphite Grease we have had her in continual service for two weeks without any trouble from hot boxes. I take great pleasure in recommending your grease to anyone experiencing difficulties of this kind.*

We have a very interesting Book on the whole theory and practice of Graphite Lubrication.

Ask for Booklet No. 69-C and it's yours, FREE.

SAMPLES  
ON REQUEST

JOSEPH DIXON CRUCIBLE CO.  
JERSEY CITY, N. J.

Height from rail to top of B Mast...	5 ft. 9½ ins.
Height from top of rail to bottom of center channels at bolster....	2 ft. 6¼ ins.
Height from top of rail to top of center channels .....	3 ft. 6¼ ins.
Height top of rail to center of coupler .....	2 ft. 10¼ ins.
Distance from center to center of trucks .....	24 ft. 0 ins.
Wheel base of trucks.....	5 ft. 6 ins.
Center of journals, transversely....	6 ft. 8¼ ins.
Size of journals.....	5½ x 10 ins.
700 pound, 33-in. diameter wheels.	
5½ x 10-in. openhearth steel axles.	
100,000-lb. helical truck springs.	
Malleable iron journal boxes and lids.	
Standard Steel Car Company Brake Beam.	
Westinghouse air brakes.	

### Patching a Mud Ring.

Our sketch shows how a mud ring corner was patched in position and with-

folded up round the former so that it practically became a channel with a curve in it. Its section at any point was like the letter U. It tapered from the bend in both directions, being 5¼ ins. high at the center and 4¾ ins. at the ends. The patch extended along the straight portions of the mud ring far enough to take at least two bolts.

The patch was made to fit the corner as closely as could be done without putting it on, and shrinkage was allowed for. When everything was ready and the corner thoroughly cleaned, the patch was heated and put in place, and 1 in. turned steel bolts were driven in and tightened up and riveted. Two steel bolts were also driven in close to the

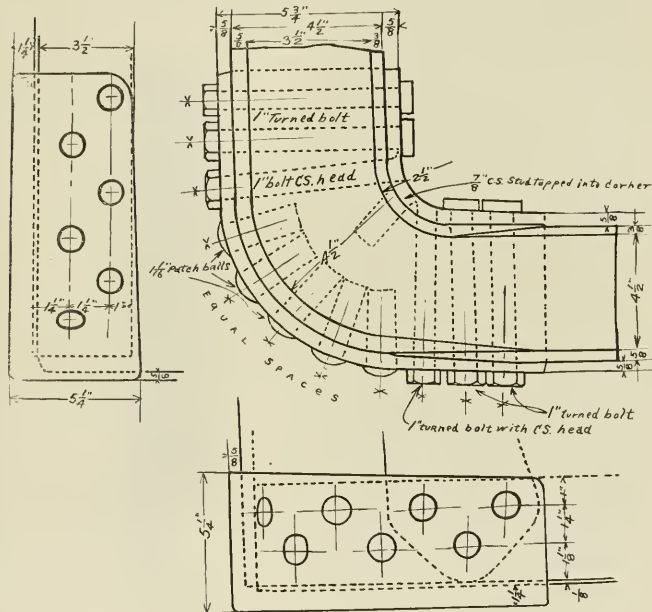

MUD RING PATCH, WINNIPEG SHOPS, CANADIAN PACIFIC RAILWAY.

cut taking down anything but the ash pan. The work was done in the Winnipeg shops of the Canadian Pacific Railway, of which Mr. S. J. Hungerford is superintendent. The engine had what is sometimes called a wide fire box; that is, it was wider than the frames, though it was not a Wootten box.

The mud ring had cracked in the right back corner, all the way across and more than three-quarters of the way through, and the problem was to make it tight without taking out any great number of rivets, or otherwise disturbing things. A former was made as nearly as possible like the corner with the plates covering the ring, and a piece of good boiler plate 5/8 in. thick was

bend and these had countersunk heads. One 7/8 in. cast steel stud was tapped into the sharpest part of the bend, on the inside, and five 1 1/8 in. patch bolts were tapped into the ring along the outer curve of the corner. When the U-shaped patch cooled it drew the crack up tight and the bolts held everything in place. The outer edges of the patch were then caulked and a perfectly tight corner was the result.

This is probably the first time such a piece of work was satisfactorily carried out, and with comparatively so little trouble. Mr. William Cross, assistant to the second vice-president of the road, has been kind enough to furnish us with the information concerning this

patch. The motive power department for Lines West, of which Mr. Cross is the head, may be congratulated on this having successfully turned a difficult corner.

#### Irresponsibility.

The serious rear collision which recently took place at Baker Bridge, by which a large number of people were killed and injured, seems to us to reveal a curious species of irresponsibility on the part of the men who were primarily responsible for the disaster.

The accident, if it may be so named, was caused by a heavy express train hauled by two engines following a local train, overtaking it and eventually colliding with it about 8.13 P. M. The road in question is not block signaled in the usual sense of that term, but at stations and at points where a man is permanently on duty a green flag by day and a green light by night are displayed for five minutes after the passing of a passenger train, and for ten minutes after a freight. Two of these caution green lights were passed by the express train without apparent reduction of speed, and three ten-minute fuses dropped on the track by the local were also passed, and the inevitable result of this kind of running came about when the express crashed into the rear end of the local.

The engineer of the head engine plainly disregarded the signals displayed, and the engineer of the second engine did the same. In fact, it is stated that this man on seeing the caution light at Lincoln, and being aware of the speed of the train when this light was passed, said to his fireman that if they were going by signals like that they would have to drag him along, and he, therefore, shut off steam. Neither of these engineers was over-worked nor was anything the matter with them as far as can be learned. Both were considered thoroughly competent men and yet they collided with a train ahead, while they were in full possession of all the information concerning its position, requisite for the safe management of their own train.

The lack of obedience to signals is one of the crying evils in train operation today, and it seems to show a curious sort of irresponsibility on the part of otherwise efficient men. Why the first man did not, as a matter of course, instantly act, as a supremely important part of his duty as engineer, on seeing the caution light, has not yet been satisfactorily explained, and why, if the report is true, the second man should, in speaking to the fireman, have admitted his obligation and have emphasized his knowledge of danger so far as to shut off steam, and yet do nothing to make the man in front realize their peril, is also without satisfactory explanation.

This kind of deplorable irresponsibil-

ity on the part of these men, and the tacit acquiescence of their firemen, shows that something more than a knowledge of rules and road and the ability to temporarily repair a breakdown, is required in the makeup of a modern locomotive engineer.

The existence of the lack of responsibility which always makes for safety, is being forced upon the attention of the public and the feeling of dissatisfaction with the whole system, manifested everywhere at each fresh outbreak of irresponsibility on the part of engineers, will surely take shape in some form of legislation which will make the mere disregard of a warning or a danger signal a criminal offense without reference to the results of such disregard.

All concerned cannot too soon read the writing on the wall and heed, the inter-



RELIABLE AIR HOIST.  
Description on page 32.

pretation thereof. The automatic stop signal is looked upon with favor by many, owing to just such occurrences as the Baker Bridge collision. That many roads are alive to the seriousness of the situation is evidenced by the fact that rigid discipline is being more and more enforced in the matter of implicit obedience to signals and it is also shown by the fact that so-called "surprise" tests have been introduced on many roads in order to collect reliable information on the subject of obedience and to weed out the

## The Best Books for Railroad Men

### AIR BRAKE CATECHISM

Price,  
**\$2<sup>00</sup>**

By Robert H. Blackall. 20th Edition. Contains 1500 Questions and their Answers on the Westinghouse Air Brake, which are strictly up-to-date. Includes two large Westinghouse Air Brake Educational Charts printed in colors. Gives the necessary information to enable a railroad man to pass a thoroughly satisfactory examination on the subject of Air Brakes. The author's many years' experience as Air Brake Inspector and Instructor enables him to know at once how to treat the subject in a plain, practical manner. Endorsed and used by Air Brake Instructors and Examiners on nearly every railroad in the United States. The standard and only complete work on the subject. 312 pages.

### LOCOMOTIVE BREAKDOWNS AND THEIR REMEDIES

Price,  
**\$1<sup>50</sup>**

By Geo. L. Fowler. Just issued. Tells how and what to do in case of an accident or breakdown on the road; includes special chapters on Compound Locomotives. Better procure a copy, as it contains 800 Questions and their Answers on Accidents and Breakdowns.

### LOCOMOTIVE CATECHISM

Price,  
**\$2<sup>00</sup>**

By Robert Grimshaw. 23rd Edition. Is right up-to-date and contains twelve large Folding Plates and 1600 Questions and Answers on How to Run a Locomotive. The Standard Book on the subject, being written in plain language and free from mathematical formulæ and complex problems.

### NEW YORK AIR BRAKE CATECHISM

Price,  
**\$1<sup>00</sup>**

By Robert H. Blackall. The only complete treatise on the New York Air Brake and Air Signaling Apparatus, giving a detailed description of all the parts, their operation, troubles, and the methods of locating and remedying the same. 250 pages.

### COMBUSTION OF COAL AND THE PREVENTION OF SMOKE

Price,  
**\$1<sup>50</sup>**

By Wm. M. Barr. Contains over 800 Questions and their Answers on the Science of Steam Making.

### AIR BRAKE CHARTS

Price,  
**50c.**

Showing the Westinghouse Equipment in ten colors, including freight and passenger engine. Every railroad man should possess these charts at this low price.

A Special of any of these books sent on request. Any of these books Circular sent prepaid on receipt of price.

Agents Wanted  
Good Commission  
Write for Particulars

The Norman W. Henley Pub. Co.

132 Nassau Street, New York, U. S. A.



# Vulcabeston

## Air Pump Rings

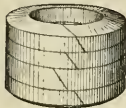

¶ Made for all sizes Westinghouse and New York Air Brake Pumps.

¶ They afford the **LEAST FRICTION, LONGEST SERVICE and GREAT-EST DURABILITY** and fit the stuffing box snugly without pinching the rod. Result: **GREATEST EFFICIENCY.**

¶ They are used by the largest railway systems in the country.  
¶ Write for copy of our "Railroad Catalog."



"A Reputation Behind It"

### H. W. JOHNS-MANVILLE CO.

Manufacturers of ASBESTOS and MAGNESIA PRODUCTS, ELECTRICAL INSULATING MATERIALS, "NOARK" FUSE DEVICES, ELECTRICAL RAILWAY SUPPLIES, etc.

100 WILLIAM STREET, NEW YORK

MILWAUKEE	PITTSBURG	KANSAS CITY
CHICAGO	CLEVELAND	MINNEAPOLIS
BOSTON	SAN FRANCISCO	LITTLE ROCK
PHILADELPHIA	LOS ANGELES	NEW ORLEANS
ST. LOUIS	SEATTLE	LONDON

irresponsible employee and the reckless chancetaker before they can get in their deadly work on innocent people and ruin the reputation of the road.

#### U. S. Output of Locomotives.

We have the very best authority for stating that during the year 1905, the total number of steam locomotives built in the United States was 4,387, and of this number 177 were compounds. That is a trifle over 4 per cent. As the number of engines built for export was 492, we, therefore, kept 3,755 engines for use on our own railway systems. During the same time 140 electric locomotives were built; this figure is, of course, not included in the total given above.

The Cole 4-cylinder balanced compound locomotive is described in a 36 page pamphlet which has been issued by the American Locomotive Company. The reasons which the writer of the pamphlet gives for recommending this form of locomotive construction to meet existing conditions are first outlined, and the engines of this type which have been supplied to the New York Central, the Erie and the Pennsylvania Railroads are illustrated from photographs, and the leading dimensions of each design are given. To show the chief details of this form of construction, the New York Central locomotive which was tested at the Louisiana Purchase Exposition was selected for description. Various engravings are used to show elevations and sections of the locomotive as a whole, the construction of the frames, cylinders, crank axles and valves. A brief statement of the performances of this locomotive on the Pennsylvania Railroad testing plant at St. Louis is presented, followed by outlines of six different arrangements showing the application of four cylinder balanced compound principle to different types of freight and passenger locomotives, and each of these types is illustrated by an outlined diagram. The pamphlet also includes an arrangement of cylinders that is served by a single valve, the cylinders being in the same transverse plane. This interesting brochure concludes with comments from the technical press concerning this type of locomotive. In view of the important requirements which four cylinder locomotives are designed to meet and the growing favor with which the principle is viewed by mechanical engineers and motive power men generally, a study of the pamphlet will be interesting to those who have to do with the selection of designs for locomotives. The American Locomotive Company will be happy to send a copy to those entitled to receive one.

The Joseph Dixon Crucible Co., of Jersey City, N. J., have been issuing a series of neat little desk blotters giving the calendar for each month as the year rolled on, and an artistic scene appropriate to the season was printed on each. The Dixon Company have branches in New York, Philadelphia, San Francisco and London, and one of their well-known products is flake graphite, used as a lubricant. They also make a variety of things, among which is paint for preserving steel structures, and, last, but not least, they turn out lead pencils of all kinds, from the car inspector's "indelible" to the editor's "blue." There is not a purpose on or off a railway for which a pencil can be used but the Dixon people have a pencil to suit that purpose, and suit it excellently. Write to the Dixon people for a blotter if you use a pen or send in an order for pencils if you prefer them, and in either case you will get good goods.

We have recently received three sheets, numbered respectively 325, 326 and 329. They came from the Watson-Stillman Company, of New York, who make all kinds of jacks. The first of these sheets illustrates their coupling bolt forcer. The action of the tool is on the same lines as a hydraulic ram, only that there is no rack and pinion return action to the ram. The tool is designed for the forcing in or out the coupling bolts of steamship shafts, but it can be used for other similar pieces of work. The next sheet shows the same kind of tool but with a movable cylinder, and the last mentioned sheets shows one with a movable ram. The dimensions of each of the tools is given and also the weight and price. The Watson-Stillman Co. will be happy to send one or all of the sheets to those interested and to give any further information to those who write to them on the subject.

#### Safe Boilers.

(Continued from page 9.)

has been placed more or less remote from the direct action of the fire, and the heat has been absorbed through the medium of tubes through which the boiler water is caused to circulate by the effect of heat absorption.

They have been generally of two classes, (1) those in which the water tubes have had only one end connected with the water reservoir, and (2) those with both ends of the water tube connected. In the latter of these we may class those which have a second or auxiliary reservoir (or reservoirs) which is generally made to serve the purpose of a mud drum or collector. Countless designs and modifications of both types have been produced with more or less

success. An excellent description of such boilers was published by Mr. M. N. Forney some years ago in the *American Journal of Engineering*. Considerable point was given to the series of articles by the small illustration at the finis, viz.: a gravestone with skull and crossbones, and the epitaph, "They could not be cleaned."

However, the funeral appears to have taken place without the necessary corpse, or some of them, as we find that the water tube boiler is now most generally adopted for stationary purposes in large installations, and wherever failure by explosion of the boiler shell takes place it is liable to cause great destruction to life and property.

While there are some good types of boilers which have the tubes connected to the water and steam reservoir at one end only, as, for instance, the porcupine type, as it is called, and which do good and economical service for stationary purposes, not being adapted for any

#### Modern Tool Builders' Plant.

The pen-and-ink sketch which we show gives a good exterior view of the new plant of Armstrong Bros. Tool Co., of Chicago. The site is an excellent one, the ground belonging to them having a frontage of 200 ft. on the Chicago & Northwestern Railway, and extending for a distance of 216 ft. on Francisco avenue. The main building has a basement and three stories, and it is of standard mill construction, with stairways and elevators enclosed in brick shafts fitted with fireproof automatic closing doors.

The dimensions of the main building are 175 ft. x 60 ft., with a one-story annex 175 ft. x 30 ft. The location and arrangement of the buildings are such that perfect light and ventilation are secured. Much new machinery of the latest type has been installed. Steel pulleys, with pressed steel hangers and roller bearings, are used throughout. Iron and sheet steel are used wherever

# GOLD Car Heating and Lighting Co.

Manufacturers of

**ELECTRIC,  
STEAM AND  
HOT WATER  
APPARATUS  
FOR RAILWAY CARS**

**EDISON  
STORAGE  
BATTERY  
FOR RAILWAY CAR  
LIGHTING**

Catalogues and Circulars  
cheerfully furnished

Main Office, Whitehall Bldg.  
17 BATTERY PLACE  
NEW YORK



ARMSTRONG BROTHERS' NEW TOOL WORKS.

other, still they do not appear to grow in favor, probably because they occupy too much space for the horse power developed.

The types of water tube boilers which appear to have survived the sicknesses due to childhood, generally speaking, belong to the class which have both ends of the water tube connected to the water reservoir or reservoirs. They may be divided into three classes (1) those which are formed of straight vertical tubes connecting two drums, as in the Cahall type, (2) those with straight tubes inclined at an angle from 20° to 40° from the horizontal and connected to the water and steam drum on top by suitable headers, and to a bottom drum or mud drum from the lowest point of the headers, as in the Babcock and Wilcox type, and (3) those which have bent tubes connecting three or more drums together to form a sort of enclosed fire box, where the steam and water drum or drums are on top, and the mud drums form the sides of

(Continued on page 43.)

possible in partitions, benches, stands, drawers, packing tables, stock racks and shelving, very little light wood being visible anywhere.

The assembling, stock and shipping departments are remarkable in this respect, and comprise one of the most complete and well-designed sheet-steel fixture installations in the country.

#### New Storage Battery.

The Westinghouse Electric & Mfg. Company, of Pittsburgh, have recently placed on the market a storage battery charging receptacle having many advantageous features, among the more important being a swivel attachment which brings the receptacle into conformity with standard steam railway practice, and allows the car or vehicle to start and pull out the cables without danger of breaking them or the contacts. The apparatus is adapted to both railway and automobile service, and has been adopted by the Pennsylvania Railroad for charging the batteries on their cars.

# Homestead Valves

Straightway, Three-way and Four-way, and

# Homestead Locking Cocks

Are Famous the World Over

They cost more, but are worth very much more than other makes. You try them and see.

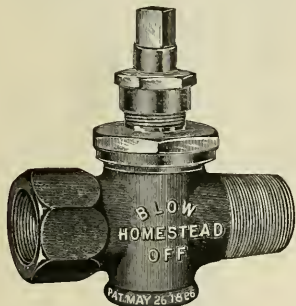

Brass, 1 1/4 in., \$6.00 net

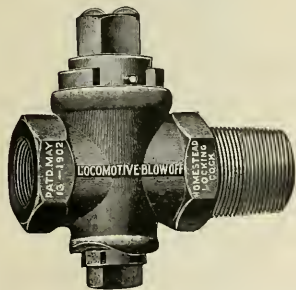

Iron Body. Brass Plug, 1 1/4 in., \$4.00 net

## Homestead Valve Mfg. Co.

WORKS HOMESTEAD, PA. PITTSBURG, PA.

### Safe Boilers.

(Continued from page 42.)

the grate as in the Thornycroft type. Those of class (1) are exclusively used in stationary installations, as they are not adapted for any other use. They appear to be reliable and economical in all respects and the only failure that the boiler is liable to is probably corrosion of the tubes at the connection to the bottom water reservoir. The effects of expansion and contraction are practically eliminated any further than the disturbance of the brick casing. They have the advantage that any mud or scale is deposited below the fire line automatically, as the bottom reservoir is below that line, and all water in circulation passes through it. There is the possibility that rapid circulation may keep the lighter particles of mud stirred up.

It will be noticed that as the water rises in that half of the vertical tubes which is hottest, being nearest the fire, so it must return downwards by those more remote, and there will be a certain number of tubes in which the tendency to rise and fall is between these, so there will be little, if any, motion. Also, the effect of the heat on the tubes with downward flow is to retard that flow.

This defect has been overcome to some extent by building a brick wall across the center to divide the tubes nearest the fire, which are properly uptakes for the water, from the more remote ones, which are downtakes. This undoubtedly avoids the dead water flues in the center, but the absorption of heat in the downtake tubes militates against the circulation of the water.

Those of class (2) with inclined water tubes are generally provided with a mud drum in direct connection with, or continuation of, the back header (or the front header, if it is the lowest, as in some modifications of this type), but the water in circulation does not pass through the drum, and while light mud may be carried by the water, any which falls into the drum connection cannot again get into circulation. In boilers of this class it is evident that, as the water tubes are at a higher temperature than the steam drum, and the lower tubes, being most exposed to the fire, are hotter than the upper ones, there is a tendency to spread the headers, greatest at the bottom, and either spring them at their connection to the drum, or to bend the drum down in the center, or both (depending upon the design of the header), and this effect of expansion must be provided against, either in the construction of the headers or in their connection to the steam drum. The more rapid the circulation of the water becomes, the less will be the difference in temperature and

amount of expansion between the tubes and the drum; consequently we find that those which have given trouble by expansion and contraction, or by burnt-out water tubes, are those which have tubes inclined only 1 1/2 ft. to 2 ft. in about 16 ft. long, and the headers with stiffness in connection to the steam drum.

It is commonly found that tubes have to be taken out of such boilers, on account of a hump rising on the lower surface of the flue where scale has collected, which will cause a burst flue if it is not removed. Such boilers as have tubes inclined about twice the above amount are free from these kinds of trouble, as the speed of circulation of the water is increased.

It should be here remarked that in these types all the tubes contain water flowing in the same direction, the return being through the steam drum after having delivered up its quota of steam. This type of boiler can be, and is, constructed in very compact form, suitable for marine service. They may be built to carry pressure as high as 400 lbs., if necessary, with perfect safety from great destructive effects by their failure, if such should occur. The foregoing types of water-tube boilers are generally set in, and cased in brickwork, except for marine service, where they are cased in plates. The remaining class (3) have been designed more particularly for steam launches and torpedo boats, in which the three drums are set in a triangular prismatic position, the upper one being the steam and water reservoir, and the two lower ones the mud drums and sides of fire grate, these being connected to the steam drum by a series of water tubes, which are bent in somewhat of a triple curved form, so as to enter the drums as nearly as practicable at right angles, and also to give facility for expansion and contraction by the bending of the tubes themselves, which is different in each row according to the temperature. This movement effectually prevents scale formation. These water tubes, however, only carry water which is moving in an upward direction, the water in a downward direction being carried by a larger pipe, more remote from the fire, and therefore not opposed by the heat. The Thornycroft boiler is a good example, and very extensively applied. These boilers do not often require repairs to the tubes, but when such repairs are required they are somewhat difficult to accomplish.

The simplicity of the straight tube, its cheapness, and the facility for repairs which it gives, are greatly in its favor, and there is at least one noteworthy attempt to overcome the evil of expansion and contraction, in the Niclausse boiler, which is a French design. In

## American Locomotive Sander Company

13th & Willow Sts., Philadelphia, Pa.

Proprietors and Manufacturers

LEACH, SHERBURNE, DEAN, HOUSTON, "SHE" and CURTIS SANDERS

### THE ROBERT W. HUNT & CO.

Bureau of Inspection, Tests and Consultation, 1137 THE ROOKERY, CHICAGO.

66 Broadway, New York. Park Building, Pittsburgh. 31 Norfolk House, London, Eng.

Inspection of Steel Rails, Splice Bars, Railroad Cars, Wheels, Axles, etc. CHEMICAL LABORATORY—Analysis of Ores, Iron, Steel, Oils, Water, etc. PHYSICAL LABORATORY—Test of Metals, Drop and Pulling Test of Couplers, Draw Bars, etc.

Efficiency Tests of Boilers, Engines and Locomotives.

this type the front header is a double chamber, the outside for the downtake, and the inside or fire side for the uptake. The water tubes are single ended and set in the back sheet, and an internal tube is set in the center sheet to act as a duct to carry the downtake water to the end of the heater tube proper, after the manner of the well-known Field tube. These boilers have shown great economy in marine service, where the water is comparatively pure, but it is extremely doubtful whether they would prove a success in general service.

None of these various types of water-tube boilers, however, have ever been adapted to locomotives, though there are at present some experimental boilers being tried, notably the Robert boiler, on the Paris, Lyons & Mediterranean Railway. The locomotive boiler has always been a comparatively safe device, for the reason that it has to undergo strains in service that cause it to open up and leak and thereby show up places that are weak before they become dangerous due to the pressure carried. This is because the strength of the cylindrical form of the barrel has been used to supplement and stiffen the frame, and owing to the great power developed and the irregularities of the roadbed, it is altogether unlikely that this formation can be superseded. It is extremely rare that locomotive boilers fail by weakness of the barrel, except due to gross neglect, and its inherent weaknesses (so far as safety goes) have been reduced to two, both of which are fire-box failures, (1) failure of crown-sheet due to low water, and (2) failure of staybolts. In class (1) there are two ways in which designers have tried to overcome the difficulty, viz., either to make the construction strong enough to carry the crown even if the plate is heated to redness, or, on the other hand, to let the plate go down and tear itself off the supporting bolts to a partial degree, and comparatively slowly, so that the escaping steam and water may lower the pressure to a safety point, and at the same time put out the fire. The other type of failure (2), staybolts, is the cause of much worry and expense, and while it has been minimized by designing the boilers to use longer staybolts, and also by the use of flexible staybolts to some extent, still the staybolt is the greatest present trouble. Of course, expense is incurred by cracking of plates, which necessitates patching, etc., but this rarely becomes a question of safety. Fire boxes without water spaces, and formed of firebricks, have been tried, but not extensively, and a few schemes have been got out for water-tube fire boxes, but none of them

have ever been made successful. Internal barrels, with drop tubes or crossed tubes, have been and are being tried to some extent, but with what result is not yet known.

A locomotive boiler, to be successful, must have (1) stiffness equal to a cylindrical barrel, (2) considerable capacity to carry deposited mud without affecting the steaming or durability, (3) must not be very liable to entire failure without long warning, (4) must be capable of temporary repairs between trips, (5) must be capable of supplying dry steam in large or small quantity at quick variation.

Since the introduction of locomotive boilers carrying working pressures of 200 to 225 lbs., the ordinary failures to which we have become accustomed, such defects as broken staybolts, cracked side sheets, grooving, etc., have become very much more prevalent, and the ordinary methods of patching have not proved nearly so durable, so that it would seem that the most advantageous pressure, with regard to the durability of the boiler, has been passed, even allowing for the superiority of modern design. Consequently, there is a tendency to revert to somewhat lower pressures. This can be done with advantage for repairs and with economy of fuel, if a suitable superheater can be used, since it is more economical to use 180 lbs. steam superheated than 225 lbs. steam saturated, as there can be no entrained water in superheated steam, and it requires less fuel to obtain a certain increase of efficiency by superheating than it does by increasing the boiler pressure.

There is a basic principle underlying the application of heat to steam boilers, to produce the safest and most economical results, which is very seldom carried out in practice. The commonest method is to apply heat to the coldest part of the boiler and let the circulation of the water distribute the increase in the resulting temperature through the mass or body of water, until it all becomes heated to a temperature at which steam may be formed at the pressure required. When steam is formed, the rising of the steam bubbles accelerates the circulation wherever it occurs in the uptake of the water, and retards it where it occurs in the downtake. If the fire is applied to the coldest part, and the flame and hot gases conducted along the boiler so as to absorb all the heat that can be abstracted, then we have a great difference of temperature between the water and the fire at the first point of contact and a small difference at the last point, where the water is hot and the gases are cool. There is therefore great absorption of heat at the first point and small absorption at the last. This proc-

## Locomotive Blow-Off Plug Valves

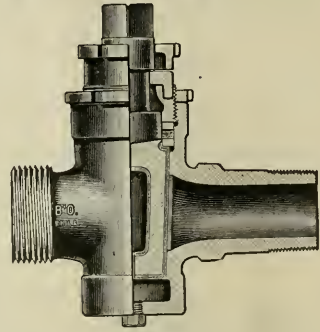

Fig. 9.

All Brass, extra heavy, with Cased Plug. For 250 lbs. pressure.

Made with Draining Plug to prevent freezing.

## Locomotive Gauge Cocks

For High Pressure

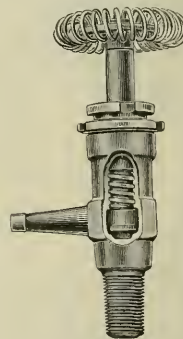

Bordo Self-Grinding Gauge Cocks, made with renewable Hard Bronze Disc. Opened and closed with a quarter turn. Guaranteed Steam tight under the most exacting conditions. Shanks Threaded to specification for Locomotives.

Fig. 23, with Wheel.

## Swing-Joints and Pipe Attachment



Fig. 33.

May be applied between Locomotive and Tender.

These Swing-Joints are suitable for Steam, Gas, Air, Water or Oil.

Complete Booklet on Application

**L. J. BORDO CO.**  
PHILADELPHIA, PA.

# Tate Flexible Staybolt

**Strong****Effective****Economical****Flexibility****Durability****Simplicity**

Holds firebox sheets securely together, and accommodates itself to the unequal expansion of the plates.

## FLANNERY BOLT COMPANY

PITTSBURG, PA., U. S. A.

Suite 308, Frick Bldg.

B. E. D. STAFFORD, General Manager

Write us for Reference Book

ess should be reversed. The greatest heat should be applied where the water is hottest, so as to raise it still more with the least loss of heat, and the waste gases should travel along in the opposite direction to the water, so that as the gases cool they are brought into contact with cooler water, which is able to abstract more heat from the gases by the difference of temperature, and the resulting temperature of the waste gases will be lower than in the first case.

There are very few boilers which work on this principle, but there are some which approach to it; for instance, in the locomotive boiler, where the cold water is introduced at the nearest point to the coldest part of the flues. There is a much better application of this principle in the Babcock and Wilcox type, where the flame strikes the hottest part of the water tube first and is afterward conducted across the colder parts.

A very good indication of the growth of our railroad system and of the supply trade which has grown up along with it is to be found in the fact that the first advertising literature got out by a prominent supply house eleven years ago consisted of a small sixteen page folder, enclosed in a 6 $\frac{3}{4}$  envelope, while now this concern issues on the same subject a standard 6x9 illustrated book of 192 pages. The present day catalogue to which we refer covers a full line of pneumatic tools and appliances, together with complete price list of repair parts, and it includes the "Boyer" and "Keller" products. In addition to this catalogue, which is No. 17, the Chicago Pneumatic Tool Co. have issued two others, one called special circular No. 52, which deals with air cooled Duntley electric drills, and the other special circular No. 55, on pneumatic appliances for foundry and concrete block work. All are well illustrated and contain information on the subjects treated which is brief and to the point. In No. 55, among other things, that useful foundry appliance, the rammer, comes in for description. That is the tool which knows enough to pound sand. Write to the company and ask for any or all of these publications.

### New Inside Molder.

Our illustration shows a new and improved molder for light or heavy work, with capacity for work 6 ins. thick, 12 or 15 ins. wide. It has been designed for car and general lumber work, and is built to meet the demands

of these industries, and all the points of excellence that could be suggested from long and successful experience have been embodied in the design of this tool.

The frame is of a new type: square, open, ribbed inside, strong and rigid. The four steel cylinders of the molder are slotted on four sides, and their pulleys taper-fitted. The upper head is double belted, and mounted on a housing which can be raised or lowered and runs on ball bearings, and is operated by a crank. The pressure bar of this head is also carried on the housing, raising and lowering with it, and it also has a vertical adjustment, as well as to and from the head. The chip breaker is in sections, each independently adjustable, and all press close to the cut.

The lower head is at the feed out end, made single or double belted, and its frame is vertically adjustable. The pressure bar before this head, also the table after the head, adjusts vertically and horizontally. Both heads are easily accessible. The side heads are

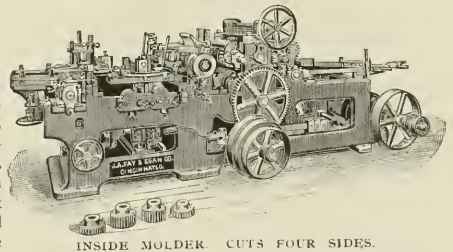

of improved construction, and are fitted with devices for facilitating operation. There are four feed rolls, the upper sectional, and either smooth or fluted rolls can easily be inserted. The feed is driven by either cone pulleys, tight or loose pulleys, or by binder, and the speed can be regulated as desired.

If you are interested, send to the J. A. Fay & Egan Co., of Cincinnati, for further information. They have a catalogue, and also a book on band saws and sanders, which they would be happy to send you.

Every railroad accident that happens brings out recommendations for the introduction of new safety appliances which are not needed and would prove sources of new danger instead of promoting safety. Automatic block signals are not new and untried novelties. They do the work of protecting trains where they are in use. Wherever a collision has happened under automatic block signals it has resulted from disobedience of simple rules. The pity is that such a small part of our railroad mileage is protected by block signals.

### Walschaert Valve Gear.

This is the title of a special pamphlet devoted to the application of Walschaert valve gear to large American locomotives soon to be issued by the American Locomotive Company, its appearance being timely in view of the interest in this valve gear in connection with conditions in locomotive construction which render this gear desirable for very heavy locomotives.

The pamphlet opens with brief statements of the advantages of this gear, as applied to recently arisen conditions which make it difficult to properly maintain Stephenson valve gear on a very large modern locomotive. Among these the accessibility of Walschaert gear is prominent. It is made clear that while this is an old valve gear, its application now to American locomotives is due to their very great increase in size and power. Incidentally the Walschaert gear effects a saving in weight and provides directness of motion, keeping stresses in nearly straight lines. It provides permanence of adjustment, reduces wear, facilitates smooth operation and permits of properly bracing the frames of the locomotive.

The pamphlet illustrates six large modern locomotives equipped with this gear, including the heaviest passenger, freight and switching locomotives ever built. Line engravings illustrate side elevations and cross sections of a number of designs, showing arrangement of the gear.

Diagrams explain the application of the motion and a table shows relative weights of Stephenson and Walschaert gear for three locomotives. Service results are included and the pamphlet also presents a general description, directions for adjusting valves and method of laying out Walschaert gear, which was specially prepared by Mr. C. J. Mellin for this pamphlet.

The pamphlet presents actual practice and theoretical considerations which are sufficient to form the basis of a general understanding of the gear and a technical description to enable an intelligent draftsman to apply it in his practice.

Yours very truly,

AMERICAN LOCOMOTIVE COMPANY  
per G. M. Basford.

For the benefit of our subscribers who indulge in the fragrant weed we have no hesitation in recommending the cigar which is manufactured by the Edwin Cigar Co., who are an absolutely reliable concern and run a large union shop. The cigars which they are advertising, although low in price, are of extremely good quality, as you will find by giving them a trial. Look at what is said about them on page 48 of this issue of RAILWAY AND LOCOMOTIVE ENGINEERING.

### Machine Made Forgings.

We have just received from Mr. W. McIntosh, superintendent of motive power of the Central Railroad of New Jersey, some photographs which we here reproduce of one-piece forgings that have been made at the company's shops at Elizabethport.

Fig. 1 shows a locomotive brace, and is a thoroughly well finished piece of work. The bar was handled in the upsetting machine until the finished product like that shown was the result. Fig. 2 is a hanger and shows an even distribution of metal and the smooth, well form-



FIG. 1.  
MACHINE FORGED HANGER



FIG. 2.  
LOCOMOTIVE BRACE.

ed outline which this class of work always presents when well done. Fig. 3 exhibits a group of machine made forg-



FIG. 3.  
MACHINE MADE FORGINGS.

ings which gives one an idea of the variety of parts which can be thus made and of the capacity of the tool.

Forgings of this description are very satisfactory for use in the internal bracing of boilers, as they present a smooth surface and are fully up to the specified size in every part. The unbroken outer skin on machine forgings gives them an advantage which in hand work it is difficult to equal.

One of the best known railway stations in London is at Charing Cross, which is conspicuous from its imposing steel train shed. Part of this shed collapsed last month and caused much damage to property besides killing several persons. This has led to an earnest controversy among engineers and contractors concerning the durability of

# THE UNION SWITCH & SIGNAL CO.

Consulting and Manufacturing  
Signal Engineers

Automatic Block Signals—Electric  
and Electro-Pneumatic

Interlocking—Electric, Electro-Pneu-  
matic and Mechanical

Electric Train Staff Apparatus

GENERAL OFFICES AND WORKS AT  
SWISSVALE, PA.

DISTRICT OFFICES:

New York: 143 Liberty Street  
Chicago: Monadnock Block  
St. Louis: Frisco Building

## The Twentieth Century Master Mechanic

Won't use Solid Mandrels.  
Cost too much, take up too  
much room and don't give  
satisfaction.

Nicholson  
Expanding Mandrels

Take everything from 1 to 7  
inch holes. Take up little  
room—always ready and  
you can buy four sets for  
the cost of one of the solid  
kind.

Are You Using Them?

Catalogue tells you  
more about them.

W. H. Nicholson & Co.  
Wilkesbarre, Pa.

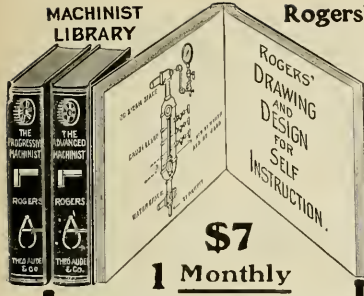

**\$7**  
**1 Monthly**

Each Volume is complete in itself and may be obtained separately.

**LIST**

- 1. Rogers' "Drawing and Design" \$3.00
- 2. Rogers' "Progressive Machinist" 2.00
- 3. Rogers' "Advanced Machinist" 2.00

**READ CAREFULLY**

The books composing the library are intended to be educational and progressing from the simple to the more complex subjects; plain books for those already engaged, or soon to be, in the practical application of the theory of mechanics; each volume is complete in itself, while progressive in the series. The books are each supplied with a ready reference index, which enables the quick use of their contents.

The volumes are strongly and handsomely bound in black cloth, with titles and edges in gold; they contain 1,204 pages, 1,244 illustrations, many of which are full pages, with 3,000 ready references; they are printed on fine surface paper with large clear type. Each book stands 8½ inches in height, and the three packed for shipment weigh over 7½ lbs. No works of equal value have ever been offered to the machinists' and allied trades, and no one from the superintendent and owner to the apprentice can afford, considering the price and terms, to be without them.

**1 DOLLAR MONTHLY**

The three volumes will be forwarded postpaid to any reader of RAILWAY AND LOCOMOTIVE ENGINEERING who sends to us one dollar and a written promise (see coupon below) to pay the balance of the purchase price in six monthly installments of one dollar each, making \$7.00 in all.

◆◆◆ **SHIPPING DIRECTIONS** ◆◆◆

Date.....  
I enclose \$1.00 (one dollar) to apply as first payment on one set of

**ROGERS' MACHINIST'S LIBRARY** which ship at once to the following address, all charges prepaid. I hereby agree to remit by mail at the rate of one dollar each month, the remaining six (6) dollars.

Signature.....  
Occupation.....  
Where employed.....  
Residence.....  
City.....  
Railway and Locomotive Engineering.

**THEO. AUDEL & CO.**  
Publishers  
63 Fifth Avenue New York

iron and steel structures. The well known fact has been vigorously emphasized that the life of an iron structure exposed to the weather depends absolutely and solely upon the thin skin of paint which must be constantly renewed, but there are necessarily many parts which cannot be reached by the paint brush, but to which water can penetrate.

The Santa Fe Railway management have appropriated \$100,000 for the building and equipping of meeting rooms to the Young Men's Christian Association for the employees of the road. Mr. S. E. Busset, who has general charge, has appointed Mr. L. H. Collett as his principal assistant. Mr. Collett was a locomotive engineer in California, and is proving a very capable man for the work now engaging his efforts. In connection with his work Mr. Collett has been lecturing on the "History of the Locomotive and the World's Relation to It." He receives the cordial support of the officials of the Santa Fe, who realize that Mr. Collett is performing good educational work.

In last month's issue we published an item saying that the Boston & Maine Railroad Company had been experimenting with peat as fuel and found it satisfactory. The item was based on what seemed to be reliable information, but Mr. Henry Bartlett, superintendent of motive power, write us: "The tests were unsatisfactory in every way, and nothing further is being done about the matter." It seems to us that the peat advocate liar is the head Ananias at present.

The proposition to place the telegraph lines under ground is being favorably considered by the Pennsylvania Railroad Company. It is estimated that the cost of constructing the conduits and making the changes would be saved in a few years by the security from storms. Work will shortly be begun on the entire line from New York to Washington.

Some people derive so much enjoyment from suing railway companies that they are willing to undergo much trouble and annoyance in their pursuit. A case of this character out of the ordinary happened in England last month. A man sued a railway company for personal damages and it was proven that he went deliberately and lay down on the track in front of a train and permitted both his legs to be cut off so that he might collect damages by pretending that he was jolted off the train. A suggestion to the act was no doubt made by the publishers of a sensational paper who offer five hundred pounds

**STANDARD MECHANICAL BOOKS  
FOR ROAD AND SHOP MEN  
BY CHAS. McSHANE**

**The  
Locomotive Up to Date**

Price, \$2.50

**New York and  
Westinghouse Air Brakes**

Price, \$1.50

**One Thousand Pointers for  
Machinists and Engineers**

Price, \$1.50

All books bound in fine cloth

AGENTS WANTED everywhere; write for terms and descriptive circulars. Will be sent prepaid to any address upon receipt of price.

**GRIFFIN & WINTERS  
171 La Salle Street, CHICAGO**

**Wm. R. Phelps & Co.**

MANUFACTURING JEWELERS.



High  
Class  
Watches,  
Diamonds,  
and  
other  
Precious  
Stones.

We make a specialty of  
Masonic and all other Emblems.

Diamonds purchased of us at present prices are a good investment. We have a fine line of the best Railroad Watches at rock bottom prices. Jewelry of every description.

**WM. R. PHELPS & CO.**  
3a MAIDEN LANE, NEW YORK, N. Y.

# HERE'S THAT'S CIGAR!

If you've a well developed taste for 15c cigars—if you never smoke a 5c cigar, except for politeness sake, then you're the man who is going to get a mighty lot of appreciative enjoyment out of the Rothschild Cigar. It costs 5c but it isn't a 5c cigar. Try to duplicate it in any retail store in the land and you'll pay 15c for it's like every time.

Every cigar we sell we make in our factory. We don't sell a single cigar to a dealer or jobber only direct from "bench to smoker" at just the prices other makers get from dealers.

## THE ROTHSCHILD

Is a superb Cuban hand made cigar (4 1/2 inches long) with an exceptionally fine long striped Havana seed filling (no shorts or scraps), and genuine imported Sumatra wrapper.

**EXACT SIZE AND SHAPE**



**EXACT SIZE AND SHAPE**

Send us \$5.00 for 100—\$2.50 for 50 or \$1.25 for 25 Rothschilds (we pay expressage) and if you don't like them after you've smoked a few, ship 'em back and we'll return money, without charging you for those you smoked.

We don't send cigars on approval because we don't want to incur the inevitable losses of credit accounts and the expenses of a large book-keeping and office force, which we would have to make you pay for in the end.

**FREE** Our Lawton 33 is sure "Tricks of the Cigar" Trade Exposure will be sent with every order. Write to-day and Get Acquainted.

*The Edwin Cigar Co.*

64-68 W. 125<sup>th</sup> ST

REFERENCES:—  
DUN AND  
BRADSTREETS

## Locomotive Boiler Building

Is shown step by step in **BOILER CONSTRUCTION** by Kleinhaus. - - - \$3.00

It's the only book that shows how all sorts of modern locomotive boilers are actually built in the best shops.

There's no theory about it. The author has built boilers in the biggest shops and knows all about the best ways and the best tools.

420 pages—334 illustrations—6 folding plates.

ANGUS SINCLAIR CO.

136 Liberty Street

New York

to persons who lose their legs in a railway accident while in possession of the paper.

The Purdue University has received a valuable addition to its engineering outfit from Mr. Henry F. Shaw, of Boston, who has presented a working model of a locomotive to the university. It is over 5 ft. in length, and embraces all of the features of Mr. Shaw's work on the balancing of the reciprocating parts of locomotives.

The author of a paper on Fuel Combustion, read at a railroad club meeting, said: Oxygen combines but slowly with fuel elements at ordinary temperatures, but when heated to a high temperature it combines rapidly and the friction of this combustion produces heat. The whole thing is theory but the usual belief is that impact, not friction, produces the heat, as the blow of a hammer heats a piece of metal.

The price of machinery shows an upward tendency during the closing months of last year. This is readily accounted for by the gradually increasing cost of labor and material, and, in many branches of trade, a shortening of the hours of labor. The increase averages 6 per cent. on fine machinery.

The Interstate Commerce Commission have issued an important regulation in regard to the percentage of air-braked cars in a train. The present legal requirement is 50 per cent. The new order, which will go into effect on August 1, 1906, raises the required proportion of air-braked cars to 75 per cent.

We should like to offer a suggestion to the secretaries of some of the railroad clubs. There ought to be on the front cover particulars of the proceedings inside. Advertising space is valuable, but a would-be reader ought to be able to find out from the cover what the inside pages are devoted to.

The Westinghouse Electric Company have perfected their pipe-thawing apparatus, and the machines can now be had in a variety of sizes from the electric manufacturing companies. A small portable transformer, weighing about 100 lbs., will be found to be admirably adapted for thawing house piping or other short service connections.

The scientific use of measurements consists in measuring existing things; the industrial use of measurement consists in making things to certain sizes.

**EARNEST**

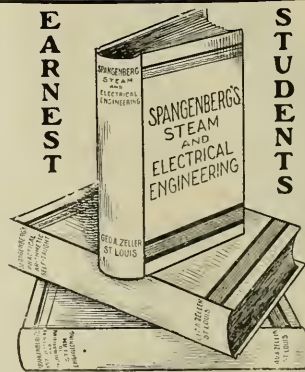

**STUDENTS**

If You Are in Earnest in the study of Engineering you want practical, clear, and reliable books on the subject. Spangenberg's Steam and Electrical Engineering exactly answers your purpose. Written by practical engineers, and written so you can understand it. Price, \$3.00. See coupon below.

**The Beginner** in Steam Engineering wants answers to his questions relating to first principles, and these he finds in Spangenberg's 157 questions and answers relating to steam engineering, a 192 page book intended for beginners only. Price, 75 cents. See coupon below.

To the boy or man whose ignorance of Arithmetic, from whatever cause, prevents his advancement, Spangenberg's Practical Arithmetic, Self-taught, supplies in easily understood form the instruction he has previously missed. With no other teacher the learner is fitted to make the calculations and solve the problems required in industrial pursuits and trades. Price, 60 cents. See coupon below.

**SPECIAL OFFER** The above three books sent post-paid on receipt of \$4.00, or in accordance with agreement set forth on coupon below. If the books are not perfectly satisfactory return them within ten days and get your money back.

**COUPON. Cut out and mail to-day.**

Geo. A. Zeller Book Co.,  
115 S. Fourth St., St. Louis, Mo.  
I accept your offer to send me, express prepaid, the above three books, price, \$4.50, and enclose \$2.50 as first payment. The balance, \$2.00, I agree to remit in 50 cent monthly installments, money, express order, or stamps.

Name.....  
Street or Box No.....  
City and State.....

## Patents.

GEO. P. WHITTLESEY

McGILL BUILDING WASHINGTON, D. C.  
Terms Reasonable. Pamphlet Sent

## Model Locomotives and Castings

Better than ever! Latest N. Y. Cen. Standard. High Saddles. Big Drivers—4 sizes. Something extra nice. 4c. in stamps for catalog.

A. S. CAMPBELL,  
P. O. Box 268, Monticello, N. Y.



# THE DUKESMITH School of Air Brakes

MEADVILLE, PA.

gives a full course of instruction in both the Westinghouse and New York Air Brake Systems, including all Text Books and colored charts, for

## Only \$10

Terms, cash or partial payments. Send us your address and we will mail you full particulars.

This is the first time railroad men have ever had an opportunity of getting a complete air brake education for a nominal sum. Write to-day.

The Dukesmith School of Air Brakes,  
MEADVILLE, PA.

F. H. Dukesmith, A. B. E., Director.

## World's Fair

St. Louis

FIRST PRIZE FOR

## TOOL STEEL

AWARDED TO

## McInnes Steel Co.

CORRY, PA.

in competition with the best makes in England and Germany. Also manufacturers of all kinds of Tool Steel, Die Blocks, and Steel Forgings.

Write for Prices and Information

### Surprise Tests.

In view of the many railroad accidents which are clearly traceable to the disregard of signals by engineers some roads have introduced a system of checking up the performance of their men in this regard. The system is popularly called "Surprise tests," but this does not seem to be a very good name, if we may judge by the definition given by a prominent official of the Cincinnati, New Orleans & Texas Pacific of the way they do things on that line.

"The so-called surprise test," says Mr. D. M. Case, superintendent of signals, "as practiced on the Queen & Crescent Line, is simply a frequent and tabulated checking up of all trainmen on signal rules by the different operating officials. The official does not trust to chance or wait until after an accident occurs, to find out whether or not his men have been obeying the rules; he gets out on the road, sets a signal at stop or displays an improper signal, puts out a light, puts down a torpedo, or makes any one of a numerous series of possible tests and then, on the arrival of a train, carefully observes the performance of the engineer and train crew. These tests have not only proved an effective method of bringing the men down to an accurate observance of signals and rules, but have brought the operating official into closer touch with the men, and this enables him to find out just how they will probably behave under fire. He gives them the tests and holds investigations before, rather than after a wreck, and he naturally finds that the greater number of the former that are held, the less there will be of the latter. He thoroughly advertises the fact that he is making these tests and the men soon come to behave in every case just as if they knew the eyes of their superior officer were upon them. This is the point to be gained, and implicit obedience to the rules soon becomes a habit and at the same time the railroad officer has the satisfaction of knowing that the men he has are absolutely trustworthy. To be complete each test should be recorded and action, if necessary, taken at once. No trainman worthy his place can object to tests of this kind; they bring no hardships to him. It is the man who is wilfully and knowingly or carelessly disobeying the rules who objects, and the sooner he is detected and put on the right track the better it will be for the lives and property of all concerned."

### Palmetto.

Asbestos is probably the best heat resisting substance which we know of, but can itself get hot when absolutely solid. Its ability to prevent the radiation of heat when used as a boiler covering, depends upon the fact that it is not manufac-

The ALDON COMPANY  
1103 Monadnock Block  
CHICAGO, ILL.

## ALDON Car and Engine Replacer



Save Time, Labor and Damage to Equipment

No Loose Parts to Get Out of Order  
Gradual, Easy Lead to Rails  
A Modern Appliance for Modern Roads

CIRCULAR ON APPLICATION

# SKAT

Best Hand Soap Known

UNEXCELLED for taking  
the SMUT and GREASE  
off RAILROAD men.

AGENTS WANTED

An attractive offer awaits  
the first man in every town  
who answers this

SKAT MFG. CO.  
791 Park St. Hartford, Conn.

## Flexible Spout

Vertically in straight  
line. Also laterally.  
The latest improvement to

## Poage Water Columns

American Valve and Meter Company  
CINCINNATI, OHIO.

SEND FOR CATALOGUE

# Locomotives, Freight and Passenger Cars

All equipment rebuilt in our Chicago shops, and at Scranton, Pa., in the new "Lackawanna" Shops

## All Kinds of Cars and Engines Ready for Immediate Delivery

RELEASED BY TRUNK LINES

1000—60,000 LBS. CAPACITY REBUILT FLATS AND GONDOLAS  
 2000—50,000 LBS. CAPACITY FLATS, BOX AND GONDOLAS  
 COACHES, COMBINATION AND BAGGAGE CARS  
 FOREIGN SHIPMENTS HAVE PROPER CARE OF  
 EXPERIENCED STAFF

Cable Address  
 "FITZLUTH"

55 AND 70 TONS CONSOLIDATIONS  
 45 AND 50 " 10-WHEELERS  
 40 TO 55 " MOGULS  
 45 TO 50 " PASSENGERS  
 SWITCHERS, FORNEYS AND SHAY ENGINES

# FITZ-HUGH, LUTHER CO. Monadnock Block, CHICAGO

141 BROADWAY  
 NEW YORK

CHEMICAL BLDG.  
 ST. LOUIS

80 ST. FRANCIS XAVIER ST.  
 MONTREAL, CAN.

RIALTO BLDG.  
 SAN FRANCISCO

tured in the solid form, but is plentifully supplied with minute air spaces throughout. Air is a bad conductor of heat, and porous asbestos is, therefore, an excellent heat resisting medium which is at the same time a non-conductor of heat. When used in this form for packing, its texture and its qualities are not altered by heat.

Flake graphite is one of the best lubricants in the world, and when this substance is used in close connection with porous asbestos we have a combination which is heat resisting, a non-conductor, and as nearly frictionless as one could desire.

In the manufacture of Palmetto packing, the asbestos used is not merely dipped or rolled in the lubricant, but is by a special process so worked as to be practically impregnated through and through with the friction reducing flake graphite. When made in the form of air pump packing, by Greene, Tweed & Company, of New York, Palmetto is composed of separate rings, of approximately square section, each ring completely encircles the piston rod, and each has a diagonal cut, by means of which the packing may be readily slipped over the rod, and these cuts when placed so as to break joints, are similar to the well-known metallic packing used on locomotive valve stems and piston rods.

This Palmetto packing, so made and so applied, forms a substance which possesses a certain amount of elasticity, and this permits the end pressure applied, to force it snugly against the rod, and at the same time it can resist the moist heat and pressure of the steam from below, and the hot drying action of the compressed air above. As every part of it is closely associated with a lubricant of high quality, wear is reduced to a minimum, and its life correspondingly increased. While perfectly steam and air tight, it does not exert any dragging action on the rod, which passes up and down inside its coils. Palmetto packing has passed beyond the

experimental stage, as is attested by its liberal use on several of our largest railroads. The makers do not ask for its theoretical endorsement by those who use it, but are willing to let the value of their product be judged under the exacting conditions of regular service tests. In thus eliminating blows, it performs the important function of reducing some of those losses of steam and air which, while insignificant when considered alone, are cumulative in their wasteful effect on the coal pile.

### Conventions Go to Atlantic City.

The joint executive committee of the M. M. and M. C. B. Associations have decided upon Atlantic City, N. J., as the place of meeting for the railroad conventions. The M. C. B. meeting takes place June 13 to 15 inclusive, and the Master Mechanics' session is held from June 18 to 20, 1906. No particular hotel will be headquarters as was the case at Saratoga, but all the exhibits will be placed on the east side of the big pier. Applications for space should be made to Mr. L. B. Sherman, secretary of the Supplymen's Association, Old Colony building, Chicago. The total amount of hotel accommodation available for the members of the conventions and their friends will be 2,400 rooms distributed throughout fourteen hotels. The prevailing rates will be for one person, single room, about \$3.50 and \$4.00, or \$4.50 for double. With bath, for one person, the charge will be \$5.00 and \$6.00. The price for two persons in a double room will be \$7.00, and for an extra large room for two, \$8.00; with bath, double room, \$10.00, and extra large room with bath \$12.00. Higher rates will be charged according to character of hotel and its location.

We understand that the Oregon Railroad & Navigation Company are about to introduce oil fuel for their locomotives on the eastern divisions.

**A Practically Perfect Portable Pneumatic**

# PUNCH

Stop moving your heavy work to the machine. One Man brings his tool to the work and punches it besides.



**SAVES TIME LABOR SPACE**

Leading concerns in all parts of the country use this Punch.

Punch Size 3

Built in 5 Standard Sizes. Special machines built to order. Write for Catalogue C.

**F. F. SLOCOMB & CO., Builders**  
 WILMINGTON, DEL.

### CONTENTS.

	PAGE.
Air Brake Department.....	25
*Armstrong Brothers' Tool Plant.....	42
*Ash Handling, Economical.....	29
Atlantic City Trades Conventions.....	60
Editorials:	
Locomotive Building, Tendencies in.....	16
Expenditure of Power.....	17
Railways, Cost of.....	17
"The Joule" and "The Thompson".....	11
General Correspondence.....	45
*Inside Molder.....	45
Irresponsibility.....	40
Locomotives:	
*Consolidation for the B. & O.....	9
*Canadian Pacific 4-6-0.....	19
*Wabash 4-6-0.....	23
*Machine Made Forgings.....	46
*Mud Ring, Patching a.....	39
Our Correspondence School.....	21
Output for Locomotives in U. S.....	41
*Panama Canal, Work on.....	1
Personals.....	33
Safe Boilers, By R. Atkinson.....	8
Shop Appliances:	
*Pneumatic Drill Adjunct.....	20
*Reliable Air Hoist.....	22
Shop Forces, Organization of.....	30
Steel Flat for Canal Work.....	33
Surprise Tests.....	49
*Tire Turning, By Geo. S. Hodgins.....	36
Walschaert Valve Gear.....	46

# Railway and Locomotive Engineering

Copyright by Angus Sinclair Co.—1906

A Practical Journal of Railway Motive Power and Rolling Stock

Vol. XIX.

136 Liberty Street, New York, February, 1906

No. 2

## Automatic Train Stopping.

The automatic stop signal idea is growing in favor with many railroad men, and the public is waking up to the fact that railroad travel is not by any

matic stop signal idea has been worked out in many forms, and the Patent Office has heard from a great many inventors in that field, but the end and object of all their efforts is to make a

more or less barbarous device because, in order to compel a stop being made, it puts the train off the track, and while it certainly halts the disobedient engineer, it may possibly injure innocent

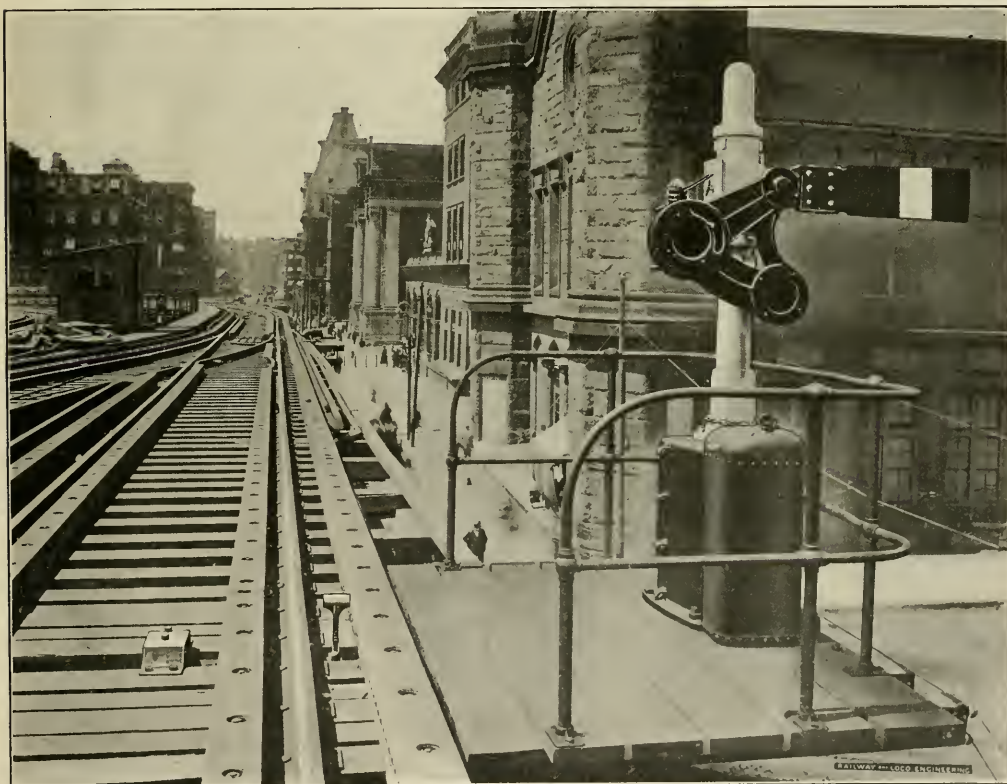

BOSTON ELEVATED AUTOMATIC SIGNAL IN POSITION TO COMPEL A HALT.—"WHEN I SAY STOP, I MEAN STOP."

means as safe as it can be made, and all the while the chance-taker, by the wrecks he causes, is constantly calling attention to the need for some device which will catch him up and show how terribly dangerous he is on a modern railway, and do it before he is able to destroy life and property. The auto-

stationary danger signal practically say to an engineer, "You stop now or I will stop you," and to enable the signal to follow up its danger indication by positive and effective action.

The derail is a device which had its origin in the necessity for enforcing obedience to signals, but the derail is a

passengers. In this sense its action is illogical because, in order to avert danger of one kind, it introduces danger in another form. The important point, however, is that this device is intended to enforce obedience in a particular case.

A member of the Railway Signaling

Club, in stating 138 to be the number of derailments at interlocking plants in Illinois for a certain year, said, "If trains run against signals when derailment is the penalty, we must infer that a much larger number is run where there is no penalty or detection except in case of disaster." The automatic stop signal is, in our opinion, superior to the derail in enforcing obedience, because it does not endanger the lives or limbs of passengers, and it affords a ready means of detecting any attempt to disobey.

Reference has been made in these columns to a train stopping signal used on Swiss railroads, in which a trip in the center of the track engages with a brake handle on the train when the adjacent signal stands at danger. We have already illustrated the invention of Mr. Thos. Cairns, a New Zealand engineer, by which a brake valve lever on the roof of the locomotive cab was made to operate when struck by an overhanging trip attached to a signal in the stop position. As proof that the stop signal is a live subject, and strongly interests inventors and also those who travel, we give some details concerning a British invention which is intended to automatically prevent a train running past a signal at which it should halt.

The device has been patented by Mr. J. C. White, an engineer living in Ayr, Scotland, and is an arrangement by which two cams or strikers are placed on the road in the vicinity of the signal, one striker close to the inside of each rail. When the signal stands at "clear" the strikers lie down below the rail level. The act of moving the signal to the stop position also raises the strikers

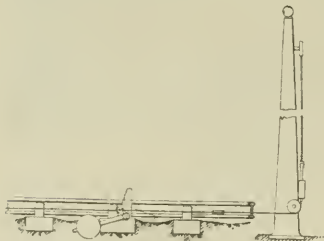

SIDE VIEW OF STOP SIGNAL WITH TRIP BESIDE RAILS.

several inches above the rails. In this raised position one or other striker will come in contact with a projecting glass tube which is part of the air brake pipe system. The collision of tube and trip shatters the glass and causes an emergency application of the brakes. The patent also includes means for readily replacing the broken tube after the stop has been made. The specification does not exclusively require the use of a glass tube, for it is stated that "at the lowest part of this connection is inserted a hollow glass ball, bulb or tube of

glass or any other suitable material of sufficient strength to withstand normal brake pressure but easily broken when it comes into contact with the lever of the cam striker."

On the Boston Elevated Railway the automatic stop signal has long been in successful operation. The apparatus

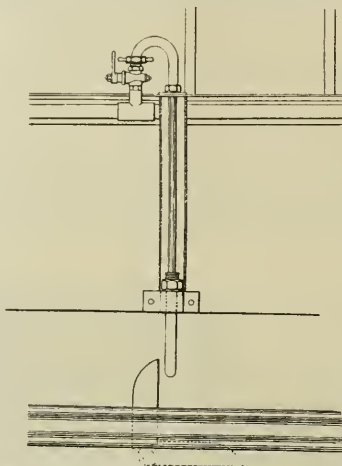

STOP SIGNAL EQUIPMENT WITH GLASS TUBE COMING IN CONTACT WITH TRIP.

used was installed by the Union Switch and Signal Company, and consists of a T-headed trip just outside the rail, which works in conjunction with the signal so that if the danger signal be overrun it strikes the hanging handle of a stop cock and carries it back to the open position, and thus secures an emergency brake action. When the automatic stop was introduced on that system there were some cases of disregard of signals, with the consequent halting of the train minus accident or mishap. This was, of course, followed in every case with the unconvincing explanation of a man caught in the act, and the net result achieved came to be that signals were and are respected all over the line.

It may be argued that stop signals which are thoroughly respected do not often get a chance to show their efficiency, and are therefore costly devices both in original outlay and maintenance. This is true as far as it goes, but the price paid is not too high for safety, and the installation may be looked upon as very efficient insurance against accidents. A great many people would smuggle if there was no fear of detection by customs officers, and the stop signal, like the custom house, has a moral influence constantly directed toward preventing actions which, when committed, it is bound to detect and expose.

Other people exclaim against the stop signal that it has a tendency to

produce automatic discipline instead of that of a more personal and rational kind, and that it tends to make engineers rely upon a mechanical device rather than on their reasoning faculties and their good judgment. The evils of automatic discipline are more fancied than real. Honesty is a noble virtue, yet the numerous automatic cash registers and fare recorders, the timekeeper's clock, the night watchman's detector and, in fact, ticket selling itself, are all more or less successful efforts to produce a purely automatic and uniform degree of honesty, yet the human virtue which we all admire in no wise suffers.

The objection that reliance will be placed upon a mechanical contrivance, and that good judgment will in part disappear, is not as weighty an argument as at first sight appears. Belief in the efficacy of the air brake and its absolute necessity in train operation is a matter upon which there can be no two opinions, and yet the air brake is a complicated mechanism, made up of many parts, capable of very fine adjustments, and requiring constant and painstaking attention to keep it in order.

The point which appeals to the railroad traveler in connection with the automatic device is the certainty of a prompt and timely stop in the presence, or even in the shadow, of danger. It is the failure of personal discipline, or the absence of good judgment, in times of emergency which has brought the automatic stop to the fore, and which will probably hasten its adoption. At the present time there are roads whose managers are ready to adopt a good, workable stop signal of moderate cost, which will be efficient in

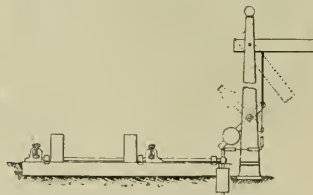

SIGNAL IN STOP POSITION WITH CAM TRIPS UP.

all weathers, and which can be maintained on a reasonable expenditure. The stop signal requires no surprise tests to prove that railroad men are efficient; it is simply a safeguard against possible mishap, and, like the so-called "dead man's handle" on the controller apparatus of an electrically driven car, it does not destroy individuality; its aim is to sharpen attention to duty, and, as far as man-made devices can act, to eliminate the possibility of human failure.

To show that automatic train stop-

ping has appealed to operating officers, we may say that when Mr. Frank Hedley, general manager of the Interborough Rapid Transit Company of New York, was general superintendent of the Chicago Elevated, he devised,

closed again, the reverse order of interlocking lever movement (finishing with the dropping of the air brake trip, and the lowering of the danger signal) guaranteed the continuity of the line. The signals and the automatic stopping

Subway. The electrical part of the arrangement here adopted is that known as the Kinsman system, and, like the Boston device, the stoppage of the train is brought about by the emergency application of the brake if an accidental or intentional attempt is made to pass a danger signal. In the Subway a T-headed trip outside one of the rails, like the one in Boston, is made to stand up above the rail level when the signal indicates stop, and to lie down, out of the way, when the "clear" indication is given. The cars are equipped with a system of air brake piping which has an ordinary hose connection carried down to almost rail level and nearly in line with the T-headed trip. In the open metal head of the hose coupling a dummy coupling is inserted, and it is held in such a position as to resist the air pressure within the hose. The lower end of the hose is capable of adjustment for height, and the dummy coupling has a sort of broad, flat, fish-tail end, which comes in contact with the upraised head of the trip in case an attempt is made to pass the signal.

The action of the trip on the projecting fish-tail end of the dummy coupling is to knock the dummy clear out and away from the coupling, but it is prevented from falling on the ground by a short chain which allows it to dangle from the metal end of the hose connection. The knocking out of this dummy

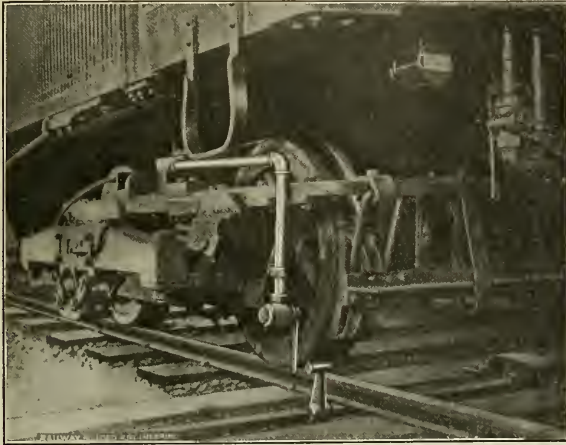

AUTOMATIC STOP DEVICE USED ON THE BOSTON ELEVATED, SHOWING TRIP AND AIR VALVE WITH HANGING HANDLE.

without patenting, an automatic train stop which was used on the approaches to two river bridges in that city. The apparatus was similar in principle to those which we have referred to, but was used in connection with the interlocking installation at the bridges.

The system was briefly that the bridge tender was powerless to move the swing span until it had been unlocked at each end by towermen, who were at all times on the elevated structure. These men could only unlock the bridge after they had blocked the road. The sequence of lever movement was devised with much care, and it was impossible to use the levers except in the predetermined order; this means that the danger signaling and the absolute blocking of the railway line was assured before the continuity of the track could be interfered with.

In order that the swing bridge might be opened the towermen on the structure were obliged to first raise the semaphore arms to the danger position, then they were compelled to set the automatic train stopping devices; next they had to unlock the rails at the point where swingspan and elevated structure joined. Then they raised the short rails on the bridge approach, so that the swing span might clear, and lastly, having performed these operations in the order named, they were then able to unlock the electric controller by which power to move the bridge could be turned on.

When the bridge had been opened and

device are thus seen to have been the first in evidence when train movement had to cease, and they were the last to be altered when the road was again

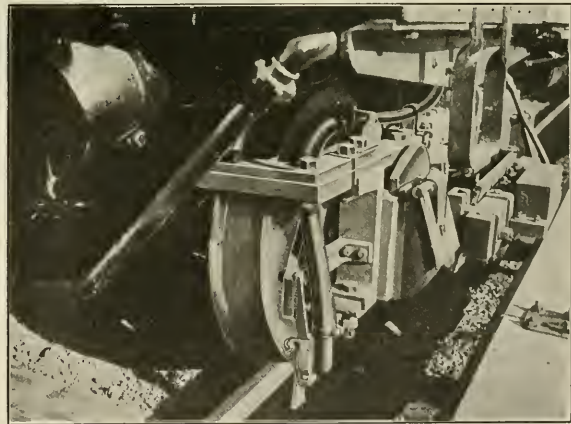

AUTOMATIC STOP DEVICE USED IN THE NEW YORK SUBWAY. THIS SHOWS THE DUMMY COUPLING WITH WIDE FLAT LUG, READY TO ENGAGE WITH THE TRIP PLACED NEAR THE RAIL AT EACH SIGNAL.

ready for traffic. Mechanical interlocking was the means employed, and safety was the watchword of the whole.

Perhaps the latest form of automatic train stopping device is to be found on the express tracks of the New York

coupling is equivalent to the bursting of a hose connection, or to the parting of the train, and powerful brake action instantly follows.

There is another feature introduced by this sudden slowing down of the

train which affects the electric current flowing to the motors. If the man in charge, with any hope of proceeding after the brakes have set, holds the controller handle full on, so that current continues to flow, the slowing of the motors due to the brake action on the train will very quickly produce such an electrical overload as to blow out the circuit breakers and thus automatically cut off the current. The New York Subway, in which automatic train stopping is used, has been very successful in its operation, and although all who traveled in it did not go on express trains, yet the amount of traffic over the automatically protected tracks was very large. Last year the total number of passengers carried per day exceeded 500,000. The trains run per day were 1,500; and the signal movements in the same time were 197,000. In the rush hours the maximum number of trains moved in one hour was 113, and this on a road where the equipment is such that there is a car for every 188 feet of track.

If one of the Subway danger signals is overrun, the train is stopped in the shortest possible space, and the brakes cannot be released until some one gets down on the ground and puts the dummy coupling back in place. This is also the case on the Boston Elevated, as the handle of the brake pipe valve cannot be turned back into the shut position after striking the trip until the train has been stopped and a man gets down and does it. If the circuit breakers have been blown they must be closed before the train can proceed, and in any event time is afforded for the trainmen to get together and consider what they are about, instead of having the train rush on, through the irresponsible behavior of one man.

The Boston Elevated and the New York Subway signals may not be able to use spoken language, but they stand for the present tense, and are always in the imperative mood. What they mean may fairly be translated by the expression, "When I say 'Stop,' I mean 'Stop.'" Give prompt action or I'll strike quick action."

#### Radium.

Certain substances of which radium is the type, have the power of spontaneously emitting radiations similar to the now well-known Röntgen Rays—rays which have the power of acting on a photographic plate, of passing through so-called "opaque" substances, and of "ionising," that is, electrically charging the air through which they pass. In the case of radium, these rays are so powerful as to cause a distinct display of energy in the form of light and heat, and the amount of energy thus obtained has been found to be so great in pro-

portion to the quantity of radium employed as to lead to the most sensational speculations as to what would be possible were a sufficiency of that element available.

Any hopes, however, of obtaining this wonderful element by the ton have, so far, not been realized, and the speculations referred to have received the usual treatment accorded to a nine-days' wonder. Scientists, however, have not left the subject alone, and one by one important facts have been brought to light. Each fact, though apparently trivial in itself, is a contribution to an hypothesis which bids fair to revolutionize the accepted theory of matter.

#### Defective Bending Tests.

With regard to tests of boiler plates, ship plates, etc., made of mild steel, no doubt the cold bend test is about the most important, but it should be borne in mind by inspectors of such material that it is also a very unfair test if the edges of such test pieces are simply left as cut by the shears, owing



OUR MOST NORTH AND WESTERLY CLUB RAISER IN CANADA. ON THE EQUI-MALT & NANIMO RAILWAY.

to the crystallization or hardening of the material all along the sheared edge of the piece, caused by the pressure of the shear blades, which hardening effect causes the piece to break short during the bending test. This more especially applies to the thicker plates from  $\frac{3}{4}$  in. upwards, and all test pieces selected for bending should be planed on the edges in order to obtain a satisfactory and fair result, and the pieces bent with a good radius at the commencement, and afterwards flattened down by pressure until the required angle is attained; for by bending it round with a small radius at first, there is not enough space for the compressed metal to occupy on the inner side of the test piece, and the local extension or flow of the metal on the outside is distributed over too short a distance, causing fracture before the desired angle has been reached, whereas with a little care probably the test piece would have given a perfectly satisfactory result.

#### Reworked Asbestos.

The Central Railroad of New Jersey are not throwing away any old asbestos lagging which comes off engines going through the Elizabethport shops. The more broken the asbestos is when it comes off the engines, the better Mr. G. L. Van Doren, the shop superintendent, likes it, because, when broken, it goes through the mill all the quicker.

Just outside the shop door, at the erecting end of the main building, there is a homemade mill consisting of two rollers studded with teeth. These rollers are, of course, boxed in and so is the electric motor which drives them, and all look about as dusty as the miller who wore a white hat. The mill grinds up asbestos slabs and broken fragments, and the product in the form of a light, powdery fluff, drops down.

When sufficient asbestos has been ground up the outside overhead crane lifts the receptacle which holds it to a convenient place and a certain amount of well broken up hemp rope, sawdust and slaked lime is added, and, after water has been poured on, the whole is mixed up to the consistency of mortar and it is then ready to be plastered on a boiler, and, when it hardens, it becomes a good heat resisting cover.

Asbestos is at its best as a heat resistor, but when closely packed it is a heat conductor, and that is not a good quality for boiler lagging to have, and the C. R. R. of N. J. are fully alive to the fact. That is why the sawdust, the hemp rope and the lime are added.

The mixture is only made as required and is put on at once; the lime then begins to eat up the particles of sawdust and hemp, and, as each is eaten up, a small air space is left. As the sawdust was thoroughly mixed all through the asbestos, the net result is that the boiler covering becomes practically porous and air, as everyone knows, is a bad conductor of heat. The boiler lagging is, therefore, porous asbestos, which is not affected by heat, and in this form is also a good non-conductor. Thus a very serviceable product has been achieved, which has the additional merit of economically using over again otherwise useless asbestos.

#### New York Railroad Club.

The annual meeting of the New York Railroad Club, held in November, was largely attended and the election of officers resulted in the re-election of the entire board of officers, including Mr. H. H. Vreeland, President; Mr. W. G. Besler and Mr. R. S. Hayward, Vice-Presidents; Mr. R. M. Dixon, Treasurer, and Harry D. Vongt, Secretary. The membership is over 1,300 and the Treasurer's report shows a balance of \$12,602. At the November meeting an able

and instructive paper was presented by Albert E. Sellenings, M.D., on "First Aid to the Injured in Railroad Establishments." The paper called forth many valuable comments from Dr. C. S. Parkhill, surgeon of the Erie Railway; Dr. Samuel W. Latta, of the Pennsylvania; Dr. I. R. Trimble, of the Baltimore & Ohio, and Dr. F. A. Goodwin, of the Erie. Dr. W. B. Coley, of the New York Central, also contributed to the debate, and Dr. Sellenings closed by

wheel base of the engine is 22 ft. 11 ins. The main rod is of T-bar section, while the side rods are plain.

The boiler is a straight top one and is 66 ins. in diameter at the smoke box end. The total heating surface amounts to 2,315 sq. ft. The tubes are 200 in number and are 14 ft. 6 ins. long. The fire box is wide in the sense that it comes out beyond the frames. The dimensions of the box are 84½ ins. long, 66 ins. wide, with a front depth of 64½

tons of coal. The tender frame is made of structural steel and the whole is carried on two arch bar trucks. There is a step on the back of the tender. The weight of engine and tender taken together is 246,860 lbs., and the full length wheel base is 51 ft. 1¼ ins. A few of the principal dimensions are appended for reference:

Boiler.—Type, straight; thickness of sheets, 11/16 in.; fuel, soft coal; staying, radial. Fire box, thickness of sheets, sides, ¾ in.; back, ¾ in.; crown, ¾ in.; tube, ½ in. Water space,

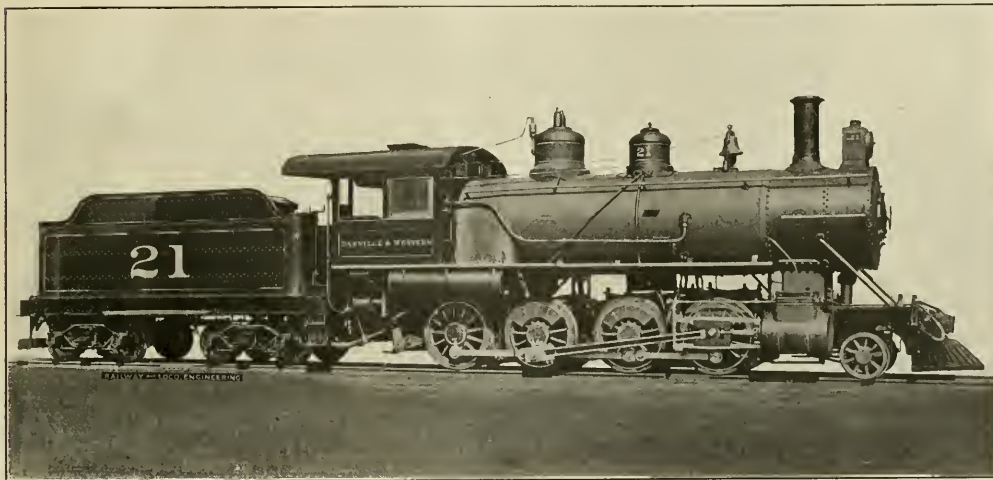

CONSOLIDATION ENGINE FOR THE DANVILLE & WESTERN.

L. C. West, Supt. Motive Power and Machinery

Baldwin Locomotive Works, Builders

giving an interesting illustration of the use of the triangular bandage.

The December meeting was chiefly occupied in witnessing a fine display of stereopticon views of a number of the Railroad Y. M. C. A. buildings, of which there are now 137 in America and many more in course of construction. The club enters on the New Year under the most favorable conditions.

**Danville & Western 2-8-0.**

Some heavy freight power has recently been shipped to the Danville & Western Railway by the Baldwin Locomotive Works in the shape of several simple consolidation engines having cylinders 20x26 ins. and 51-in. driving wheels. The weight of the whole machine is 149,080 lbs. The engine truck carries 15,220 lbs., which leaves an adhesive weight of 134,760 lbs. The boiler pressure is 200 lbs., and the calculated tractive effort is about 34,666 lbs. and the ratio of tractive effort to adhesive weight is as 1 is to 3.88.

The valve gear is of the indirect type and balanced slide valves are used. All the wheels are flanged and the driving wheel base is 15 ft. 3 ins. The total

ins. and a back depth of 54½ ins. This gives a heating surface of 126 sq. ft. and the grate area is 38½ sq. ft. The dome is 31½ ins. in diameter and is set upon the second course. The dome liner, which we show in detail, is pointed in front and forms not only a stiffening plate where the dome opening is cut, but it forms the welt for the barrel

front, sides and back, 4 ins. Tubes, wire gauge, No. 11; diam., 2 ins. Driving wheels, journals, 8 x 10 ins. Engine truck wheels, front, diam., 28 ins.; journals, 5½ x 10 ins. Tender, wheels, diam., 33 ins.; journals, 4¼ x 8 ins.

**Joy's Valve Motion.**

Radial valve motion, as represented by Walschaert and other gears, are

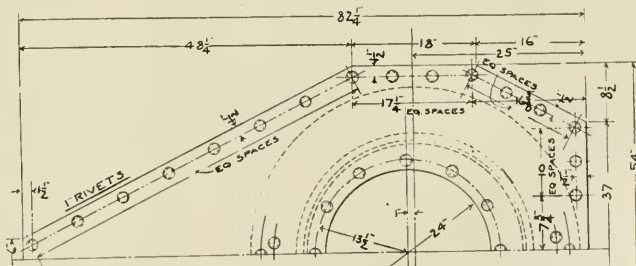

DOME LINER FOR DANVILLE & WESTERN BOILERS.

seam in this course. The dome opening is 24 ins.

The tender is made with the ordinary U-shaped plan for the tank, which holds 4,500 gallons of water and carries 8

receiving so much attention from American railway men at present, that we think it timely to show to our readers another radial motion that has attained some popularity abroad. This is the

Joy motion, used largely on some British railways, also in some of the British colonies, and in Japan. It appears to us that Joy's motion possesses some features superior to the Walschaert motion, for it has no eccentric or axle connections, besides having fewer moving parts and motion pins.

The motion for the valve is taken direct from the connecting rod and by

the lower end of a lever, *E*, from the upper end of which lever the motion is transmitted to the valve spindle by the rod *G*. The center or fulcrum, *F*, of the lever *E*, partakes also of the vertical movement of the connecting rod to an extent equal to the amount of its vibration at the point *A*; the center *F* is for this purpose carried vertically in blocks which slide in slots in the links

of the links, and the direction of which is governed by their position.

The forward or backward motion of the engine is governed by giving the slots this inclined position on one or other side of the vertical center line; and the amount of expansion depends on the amount of the inclination, the exactly central or vertical position being "mid-gear." In that position steam

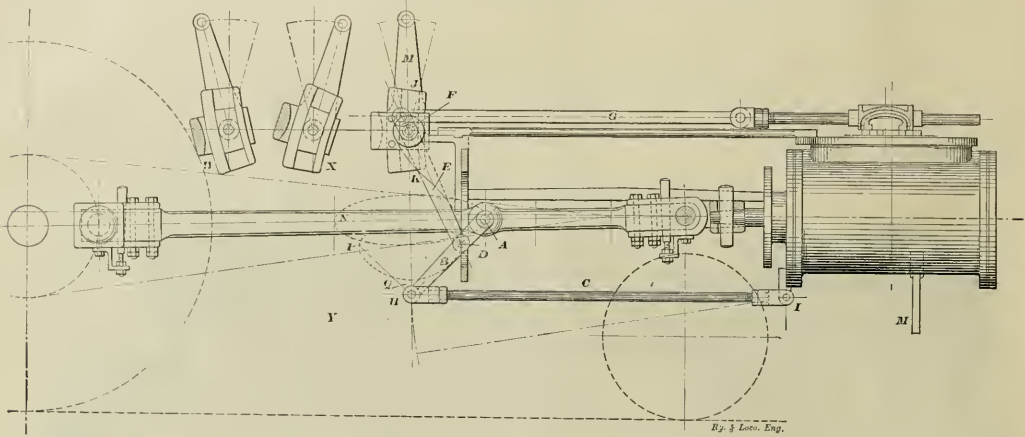

FIG. 1. ELEVATION JOY'S VALVE GEAR.

utilizing independently the backward and forward action of the rod, due to the reciprocation of the piston, and combining this with the vibrating action of the rod up and down, a movement results which is employed to actuate the valves of engines using any combination of lap and lead desired, and giving an almost mathematically correct cut-off for both sides of the piston for forward and backward motion, and for all points of expansion intermediately. The action of the gear may be understood by reference to the engravings, Figs. 1, 2, 3 and 4, which are respec-

JK, which are curved to a radius equal to the length of the rod *G*, connecting the lever *F* to the valve spindle. These links are attached to a shaft, *L*, Figs. 2 and 3, corresponding to the ordinary lifting shaft of a link motion. The center of this shaft corresponds to the position in which the fulcrum, *F*, of the lever, *E*, is represented in Fig. 1. The shaft, *L*, and the links can be partially rotated on the center of the former, so that the slots in the links will be inclined over to either side of a vertical position, as shown at *W* and *X*. This is done by means of an ordinary

is admitted at each end of the stroke to the amount only of the lead; and this is done exactly equally on each side of the center line, the amount of lead being constant for forward and backward motion, and for all degrees of expansion. Thus when the crank is set at the end of the stroke either way, the center, *F*, of the valve lever coincides with the center of the slot, and therefore

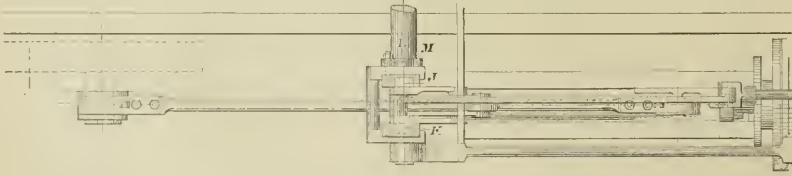

FIG. 2. PLAN OF JOY'S VALVE GEAR.

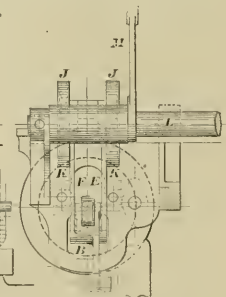

FIG. 3. SECTION ON X Y.

tively an elevation, plan a transverse section on *XY* of Fig. 1 looking forward and modified arrangement of the gear.

From a point, *A*, Fig. 1, in the connecting rod, motion is imparted to a vibrating link, *B*, constrained at its lower end, *H*, to move vertically by the radius rod, *C*, which is pivoted at *I*. From a point, *D*, on this vibrating link, *B*, horizontal motion is communicated to

verse lever connected to the upper arm, *M*, attached to the shaft, *L*. When the links are thus inclined, the vertical movement of the lever, *E*, causes the blocks in the links and the center, *F*, to traverse a path inclined to a vertical center line; and to diverge from it to either side. The center, *F*, therefore, has a horizontal movement, the extent of which depends upon the degree of in-

the slot may be moved over from forward to backward gear without affecting the valve at all.

It will be seen at a glance that if the lower end, *D*, of the lever, *E*, were attached directly to the point, *A*, on the connecting rod, it would travel in the path of the ellipse, *AN*, represented by dotted lines, and there would be imparted to the center, *F*, of that lever, an



unequal vibration above and below the center of the links, *JK*. The extent of inequality would be twice the versed-sine of the arc described by the lower end, *D*, of the lever, *E*, and this would give an unequal port and unequal cut-off for the two ends of the stroke. But this error is corrected by attaching the lower end, *D*, of the lever, *E*, to the vibrating link, *B*; for while the point *A* in the connecting rod is performing a nearly true ellipse, the point *D* in the vibrating link *B* is moving in a figure, *DOPO*, Fig. 1, like an ellipse bulged out on the lower side, and this irregularity is so set as to be equal in amount to the versed-sine of the arc described by the lower end, *D*, of the lever, *E*, thus correcting the above error, and giving an equal travel to the center, *F*, of the lever above and below the center of the slot. At the same time the error introduced by the movement of the end of the valve-rod, *G*, is corrected by curv-

has been described as carried in curved slots. This plan is given as the most simple to manufacture, but if preferred the center, *F*, may be carried by a radius rod so that its vibration will make the center *F* of the lever *E* describe identically the same arc as if moving in the slots *JK*.

In locomotives with small wheels the link *C* may come so low down as to be in danger of being knocked off. For such cases—and for others when it may be considered desirable—Mr. Joy proposed the plan shown in Fig. 4, in which the link *B* is cut off at the center *D*, and is connected at that point by a rod, *S*, to a crank, *T*, on the end of the crankpin. The movement of the valve produced by this mechanism is almost identical with the other.

**First Use of the Piston.**

There is a very interesting and beautiful illustration of the principle of

the closed end of the cell and the piston, and then stops the aperture with her feet. The piston is, therefore, pushed forward as the honey accumulates behind it, till at last it reaches the open end of the cell, where it remains, hermetically sealing the vessel and excluding the air. As soon as one cell is thus charged the industrious owners commence with another. It will be perceived that these pistons are propelled precisely as in the hydrostatic press, the liquid honey being incompressible (with any force to which it is there subjected), every additional particle forced in necessarily moves the piston forward to afford the required room. Without such a contrivance the cells could no more be filled, and kept so, than a bucket could be with water, while lying on one side. Were the organization of bees closely examined, it would doubtless be found that the relative diameters of their proboscis and of the cells, and the area of

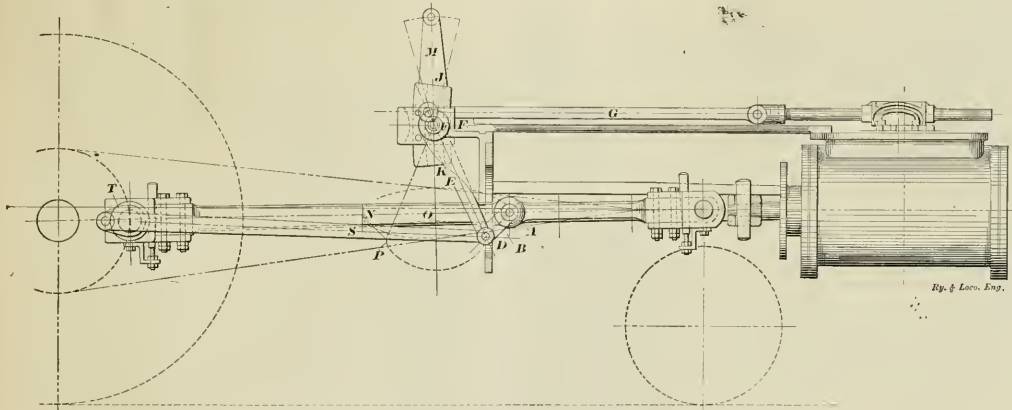

FIG. 4. JOY'S VALVE GEAR MODIFIED TO RAISE PARTS FROM TRACK.

ing the slots or links, *JK*, to a radius equal to the length of *G*.

Referring again to the equalizing of the traverse of the center, *F*, of the lever, *E*, in the slot, *JK*, the unequal traverse may be either under corrected or over corrected by shifting the point *D* in the vibrating link, *B*, nearer to or further from *A*; by this means a later point of cut off may be given to either end of the cylinder at will, and the engine may thus have more steam admitted to one side of the piston than to the other, if required. The same thing may be done for the lead. By altering the position of the crank for which the lever center, *F*, coincides with the center of the slots, *JK*, an increased or diminished lead may be given. The central positions and exact connections are, however, in all cases standard and equal.

Hitherto the center, *F*, of the lever, *E*, which gives motion to the valve spindle,

Bramali's hydrostatic press in the contrivance by which bees store their honey. The cells, open at one end and closed at the other, are arranged horizontally over each other, and in that position are filled with the liquid treasure. Now, suppose a series of glass tumblers or tubes laid on their sides and piled upon one another in like manner were required to be then filled with water, it certainly would require some reflection to devise a plan by which the operation could be performed, but whatever mode were hit upon, it could not be more ingenious and effective than that adopted by these diminutive engineers.

At the further or closed extremity of each cell, they fabricate a movable piston of wax which is fitted air tight to the sides, and when a bee arrives laden with honey (which is contained in a liquid form, in a sack or stomach), she penetrates the piston with her proboscis and through it ejects the honey between

the (bellows) pumps in their bodies are such as are best adapted to the muscular energy which they employ in working the latter. Were it otherwise, a greater force might be required to inject the honey and drive forward the piston, than they possess. In the case of a hydrostatic press, when the resistance is too great to be overcome by an injection pump of large diameter, one of smaller bore is employed.

**Robert Moran, Shipbuilder.**

Mr. Robert Moran, says the *World's Work*, arrived in Seattle twenty-eight years ago, a sturdy lad of eighteen. He came alone, and had just ten cents when he stepped ashore from a lumber ship. His first job was as a watchman on a steamer. His promotion to fireman and then to engineer soon followed, for he did his job well. At night he studied navigation and drafting; then followed two seasons in Alaska steamboating.

At twenty-two years he opened a very small machine shop, with a "hatful" of tools. At twenty-four he conceived the idea of creating a modern shipbuilding plant. He selected his site on the tide flats, and drew the plans of his proposed plant, making space for foundries, machine shops, ship ways, deep-water channels, a sawmill, pattern shops, boiler shops and cooper shops, and providing for three ways of building Government fighting ships. Twenty-three years later—last year—there was launched from Way No. 1 the \$3,800,000 battleship Nebraska, which Moran Bros. Company is building for the United States Government. The shipbuilding works cover twenty-six acres, and have an appraised value of more than \$2,000,000.

Mr. Moran had the office of mayor of Seattle forced upon him against his wishes. He was nominated and elected on a non-partisan ticket. He was mayor in 1889. On June 6 a committee of citizens started to solicit donations to a fund for the aid of the Johnstown flood sufferers in Pennsylvania. The committee had secured \$1,500 when Seattle caught fire, and by night where the city had stood were acres and acres of smoking ruins.

The mayor called a mass meeting of the citizens for 9 o'clock the following morning. It was decided to call upon neighboring cities for aid.

"What shall we do with the \$1,500 we collected for Johnstown?" asked one man.

"We'll send it to Johnstown to-day!" declared Moran.

An hour later the little telegraph office, in a tent, was transmitting requests to Vancouver, Victoria, Tacoma, Spokane, Portland and San Francisco for flour, clothing, tents, blankets, vegetables, and canned goods. But among these telegrams was one to the Johnstown (Pa.) Relief Committee, requesting them to draw on Seattle for a \$1,500 donation.

#### Notes on the N. Y., O. & W.

Middletown is a busy, thriving center of industry, nestling near the outer spurs of the Catskill mountains. The houses are closely and substantially built, and there is an air of warmth and social comfort among the frank-faced residents. This is a railroad center of considerable importance, the Erie and the New York, Ontario & Western railways both having elegant and commodious stations of massive stone structure fitted with every modern appointment at this place. The repair shops of the latter railway are also located here and employ several hundred skilled mechanics. The works are being extended to nearly twice their former size, a very large new round-house being in course of construction.

A large consignment of new locomotives had just arrived, mostly of the Wootten fire box variety, adapted for burning fine coal. Mr. Mitchell, the superintendent of the works, pointed out the various important extensions being made, and it was surprising how neat and orderly every department appeared in spite of the additional work of building new additions and installing new machines that was going on.

The instruction car, presided over by Mr. W. A. Thomson, the air brake expert, was at hand, and it was a pleasure to take a seat among the score or more of pupils and listen to the able instructions and mark the details of the complex mechanical contrivances with which the car is fitted. Mr. Thomson gave practical illustrations of applications of brakes and reductions necessary to every portion of the road, the most interesting



FRONT OF DURA-SIMPLEX RAILROAD EXPRESS ENGINE WITH SNOW SCRAPERS.

part being the fine mastery of the geographical details which characterized his earnest and eloquent address. In closing Mr. Thomson paid a warm tribute to RAILWAY AND LOCOMOTIVE ENGINEERING, and acknowledged his obligation to its pages for much that he had learned, and stated that he always urged on railroad men to peruse its pages and keep abreast of the best thoughts of the best railroad men of our time.

It is very much to the credit of the railway company that a man of Mr. Thomson's ability should be selected and kept constantly engaged in the instruction of the employees. It would be difficult, indeed, to overestimate the importance of such teachings, adding as it does to the practical value of every rail-

road man enjoying it, and to the general safety of the traveling public.

#### Record Runs in 1905.

Those interested in train speeds in this country may be pleased with the records of a regular and some special runs which were made in 1905. It is a curious fact and one which many people do not thoroughly consider, which is that the ability of an engine to get rid of steam after it has been used in the cylinders plays a very important part in high speed performance.

One of the desirable features in valve motion design is to secure the rapid and easy exhaust of steam without letting so much of it go as to cool the cylinders unduly. Too much steam entrapped by the valve gives high compression and is more than that required for cushioning. Between these two conditions lies the happy medium. Some fast engines are found to have their speed checked by being compelled to partially push exhaust steam out of the cylinders. On the other hand, letting steam go with too much "life" is not economical. This is one of the problems which confronts mechanical engineers when designing a flyer. The record of speeds made in nine cases is as follows:

Daily New York Central Twentieth Century Limited, New York to Chicago, 964 miles; average, 53.55.

May 14.—Seashore Flyer, Atlantic City to Camden, 55½ miles; average, 78.26.

June 8.—Eighteen-hour flyer on Pennsylvania, East Tolleston to Donaldson, 50 miles; average, 79.

June 13.—Twentieth Century Limited on Lake Shore, Chicago to Buffalo, 525 miles; average, 69.53.

July 9.—"Death Valley" Scott's special, Los Angeles to Chicago, 2,246 miles; average, 50.

October 23.—Harriman special, Oakland to Jersey City, 3,239 miles; average speed, 44.30.

October 24.—Eighteen-hour flyer on Pennsylvania Lines, Crestline to Fort Wayne, 131 miles; average, 77.81.

October 24.—Same train, Crestline, O., to Clark Junction, 257 miles; average, 74.55.

November 3.—Pennsylvania's 18-hour Chicago Flyer, Harrisburg to Chicago, 717 miles; average, 56.

Fathers generally try to encourage their boys to acquire a spirit of self help, the spirit that moves them to make the best of their opportunities. Certain books have been famous for the inspiration given to youths to do their best. Among recent works of this kind we think Carnegie's "Life of James Watt" deserves a high place. We earnestly direct attention to the book, especially to fathers with boys on their hands.

# General Correspondence.

## Decline in Mechanical Skill.

Editor:

The question of labor and its antagonism to capital is receiving the earnest attention of some of the most practical and philanthropic minds of the age. How to successfully and satisfactorily bridge the chasm now separating them is found to be a problem very difficult to solve. Careful examination into existing conditions reveals some truly startling facts, the most surprising of which is the rapid decadence in skill in the ranks of the mechanical classes—the disappearance of that excellence which once marked the product of the great majority in any given branch of skilled labor. The trades are not cared for as formerly; that is, there were formerly far more excellent skillful mechanics than now—men that could create, and who used not only their hands, but their brains as well, for the trade selected as a livelihood. These first-class workmen are not the people that are ever out of work; on the contrary, they are becoming scarcer every day, and every day more sought after. The unemployed, the disturbing element—the strikers, if you please—are, in great

majority, the human machines that execute their task mechanically, and either have no brains, or, if they have, make slight effort to use them; and just for this class is the age, with its greatly developed mechanical auxiliaries, a very bad time; almost everything is produced by machinery that is at all fit for it.

It would be unjust to charge this growing condition of affairs wholly to the mechanics of the day. One of the causes, and a very prominent one, too, is more remote—gained a firm footing years ago when the employer, or master workman, in the race for wealth, with little or no protest saw the apprentice system dealt a death blow by the introduction of trades unionism. Had the apprentice system been rigidly maintained, trades unionism in its present threatening aspect would be impossible;

and the mechanic, instead of depending upon coercion and "boycotting," would be self-reliant and trust to merit only; Powderly, Most, Parsons, et al., would be without a following, and one of the greatest factors for disturbance would be comparatively unknown. A remedy has been suggested, being a prompt return to old principles, the apprentice system and the employment of meritorious workmen only; non-recognition of trades unionism in any form, and a dissolution of all combinations having

point of excellence which the true workman occupies. Apprentices are too independent. They feel themselves bound by no honorable obligation to their employer, but assume a freedom of movement that prevents them from ever becoming skilled workmen. Serving one year, or perhaps two, they tire of the drudgery and aspire to the position and consideration of the workman, without the education and skill that make such consideration a legitimate result. For the first six months of his novitiate, per-



TRANSFER TABLE, MISSOURI PACIFIC SHOPS, SEDALIA, MO., SHOWING DOUBLE DROP DOORS AND WINDOW ARRANGEMENT. Courtesy of the *New Southwest*.

as objects the depression of wages; in short, for merit and justice, and they alone, to be the standard for guidance. A remedy must be forthcoming very soon; the industrial fabric is in great danger; the tension is becoming too great, and if not relieved must break, and then—revolution and bloodshed.

It has been well said by a mechanical writer that the position of workman and mechanic has been lowered as much by the incompetence of those who profess to know a trade as by any other cause. The country is full of half-taught workers who have a mere smattering of their business, who, if they have served an apprenticeship, have never learned the trade; or who, having become disgusted with the drudgery and routine of the shop, or of the apprentice stage of work, seek new positions and refuse to take the steps necessary to reach the

haps longer, the apprentice is the cause of much anxiety and no little expense to his employer. He breaks tools, mars work, muddles and boggles, and upsets the harmonious routine of the shop in many ways. He is anything but a profit to his employer. Yet these annoyances are borne in the hope and the just expectation that his after improvement will repay his present wastefulness. It is peculiarly annoying, therefore, to the employer to have his apprentice leave the shop just as he has begun to be of some use. Such a course is unfair and unjust. It is more than that; it is harmful to the apprentice himself. The country needs skilled workmen. It is only at rare intervals that business is so flat that skill is not in demand, but there are frequent periods of slackness when only skilful and reliable men are wanted. There is no royal road to the po-

sition of skilled workmen. It must be reached by the close, attentive, patient plodding of the apprentice, through the lane of learning into the broad road of competent acquirement. The entire matter resolves itself into the plain, old-fashioned rule of sticking to a business. No looking back after the hand is placed to the plow. There is hard work and unpleasant work to be done by the apprentice, but it must be done else the apprentice never becomes a workman.

READER.

#### Why Big Wheels Slip.

Editor:

All engineers know that an engine with a big wheel is "slippery," but a great many do not know why this is so. In fact, I have never heard or seen a good explanation of the reason why this is so, but think a careful study of the following will make it clear.

The accompanying sketch represents a 72-in. driving wheel, 28-in. stroke, with crank pin on lower forward eighth. When the pin leaves the forward center and moves down and back, the steam in

The lines of force from the crank pin have an upward and a downward course. The force on *B* is exerted against the rail, and on *A* it is against the wedge and frame, and weight on driving box. The greater power on *A* pushes the box up against the spring and raises the wheel off rail just enough to break the resistance there, and the wheel slips on the rail.

Watch your engine, and you will find that she nearly always starts to slip on the lower forward eighth, if she slips when starting train; either there or on the back eighth. In this latter position this lifting force is exerted also, but not in as marked a degree as on lower forward eighth.

An engine with a big wheel would not be any more apt to slip than one with a small wheel if the crank pin was placed as near outer edge of wheel on the larger size as it is on the smaller wheel.

For instance, suppose the crank pin to be at *C*, which would be 14 ins. from outer edge of wheel. The line of force

We find the calculated tractive power of the first engine would be 40,404 lbs., while the tractive power of the other, with 72-in. wheels, would be 49,723 lbs. With the same diameter of cylinders and same boiler pressure this would be a gain of over 9,000 lbs. tractive power with the big wheel, which would, of course, call for a greater weight upon drivers to get the proper ratio between adhesive weight and tractive power.

A study of the diagram will convince any one that the nearer the center of the axle you place the pin, the more the lifting effort is exerted, while for every inch you go down with the pin toward *C*, the more power the engine gains to pull her load.

The switch engine spoken of some time ago by Mr. Monfee no doubt had a small wheel, and the one with the thickest tires made it have a greater distance from the outer edge of the wheel to the pin, and in that way she would lose a certain amount of power to roll wheel and pull load, and at the same time increase lifting effort and cause wheels to slip with a lighter throttle.

E. C. ALLEN.

[Our correspondent is all right about the axle box being pressed back against the frame, and the frame being drawn ahead by the steam pressure on the front cylinder cover, but he is in error about the levers which he seems to think exist in the wheel. He reasons as if the lines *A* and *B* in his sketch were parts of a toggle joint, and that the crank pin was free to move in the wheel, which it is not. What he says might be true if the wheel broke in two and part stayed on the rail and part was raised up. As it is, the wheel does not break, and Newton's third law says that action and reaction are equal and opposite. There is no point of leverage, so to speak, whereby the wheel can be lifted. If the main rod was shoving a wedge under the wheel, the case would be different, for then the rail would be the supporting base or point of leverage, outside the wheel altogether. The cause of engine slipping cannot be explained by any analysis of the internal stresses in the wheel itself.—Ed.]

#### Simple Valve Testing.

Editor:

It has always seemed to me in my experience with the locomotive that the most vexing problems were easy of solution if the effort to solve them were properly directed. Often I sought light on these problems, only to find that the solutions offered in text-books were more mystifying than the problem itself. The reason probably is that in explaining certain operations relative to testing for, say, a broken bridge in valve seat, a broken outer wall of steam port

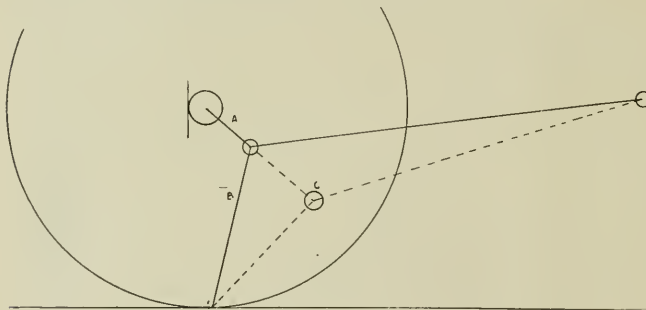

WHEEL DIAGRAM LONG AND SHORT STROKE ENGINES.

the cylinder acts against cylinder head and tries to pull forward the frame. At the same time it is forcing piston back, and this force, transmitted from crosshead through connecting rod to crank pin, pushes the driving box back against wedge, in fact, tries to push wheel backward, and would do so if there was no resistance offered but the weight of wheel itself. There is a resistance offered, where wheel rests on the rail, and in the pedestals, and the direct lines of force from crank pin to these two places are shown at *A* and *B* in the sketch with the pin on lower eighth.

When the pin leaves the forward center, the power from the piston to the pin is exerted in nearly a straight line to axle, but when the lower forward eighth is reached, the power is divided between center of wheel and point of contact with rail, as shown at *A* and *B*. Now, *A*, being the shorter line, receives the more power, or, in other words, it being the short arm of the lever, it does the more work.

*A* is now the longer, and not only that, but the line from the crosshead to the rail is more nearly through pin to the rail. The lower line now receives the push on the crank pin, the line *A* receiving but a very little.

At first one might say that there was more force exerted, in this position, on the nearly straight line below, but the steam in the cylinder is pulling the frame forward over pin *C*. The distance from the center of the axle to the pin being greater than before, it is working through a longer lever, or rather through a longer arm of the lever, and thereby gains more power to pull load, while the slipping effort has been reduced.

Now, as to power, compare an engine with 22x28-in. cylinders, 56-in. driving wheel, and 200 lbs. boiler pressure, with an engine with a 72-in. wheel. With pin at *C*, it would be the same distance from the outer edge of wheel on both engines, viz., 14 ins. This would give the 72-in. engine a stroke of 44 ins.

or a broken valve, it is necessary to make visible (or clear) to the mind that which is not visible to the eye, which is a very hard task and one that is seldom really accomplished. Testing for valve defects and defects in the brake equipment are operations little understood by the vast majority of locomotive engineers.

When first promoted I was like the majority, passed the examination "on suspicion," and learned what I should have known previously since promotion. The knowledge thus gained has come to me amid "trials and tribulations," not necessary to mention to the initiated, and I believe I have some methods that may help others to do intelligently what comparatively few engineers do successfully.

TO TEST FOR BROKEN BRIDGE.

Place side to test on quarter, reverse lever center notch, ascertain amount of lap (which is one-half distance between port marks on valve stem), note while assistant moves reverse lever when valve has moved a distance slightly greater than its lap; have throttle slightly open, and if steam blows through into exhaust heavily, a broken bridge is indicated. If in same position (on quarter) with throttle and cylinder cocks open, steam blows heavily through cylinder cock before valve is moved the distance equal to its lap, a broken outer wall or steam edge of valve is indicated. Whether it is the back bridge, outer wall or edge of valve would be easily determined from the direction the valve has been moved

and if steam shows at both cocks your packing leaks. True, the valve could cause this, but "ninety-nine to a hundred" it does not.

WHEN AIR LEAKS OUT OF TRAIN PIPE WITH BRAKE VALVE ON LAP.

This is due to a leak of air from equalizing chamber (D) above equalizing piston, which causes it to raise and open

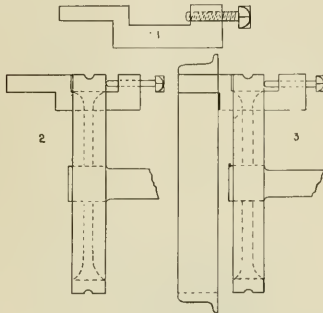

TIRE HOLDING CLAMP.

train line exhaust. In other positions it may not be noticed because main reservoir feeds air to compensate for the loss unless it is very heavy. But when valve is lapped no air goes into chamber D, so that the leakage acts the same as a reduction made from train line in the regular way and the reduction continues steadily or at intervals according to the seriousness of the leak, until train line

Clamp for Holding Tires.

Editor:

The accompanying sketch shows a clamp used to hold a wheel tire in place while being heated prior to shrinking on the wheel. Fig. 1 shows the clamp, which should be made of good steel, with set screw with fine thread. Fig. 2 shows the clamp in place, ready to receive the tire, and Fig. 3 shows the tire suspended on the clamp. When heated, the tire readily is slipped onto the wheel and cooled.

It has been customary on putting on tires to prop the tire up against the wheel, and when the tire is ready it is then wedged into place. This is a dangerous method; in case of a wedge slipping the tire is apt to roll. This clamp is an idea of Mr. MacDonald, the mechanic who attends to the tire department here.

It may be added that the wheels are raised by blocking up the axle, and the cool tire is run into place on a wedge, and is hung on the clamp and heated by crude oil or gas jets to the required heat. The clamp has been very useful to us.

J. W. PERCY.

South Tacoma, Wash.

Peculiarities of Drummers.

A buyer is like your heirress—he always has a lot of nice young drummers flirting and fooling around him, but mighty few of them are so much in earnest that they can convince him that their only chance for happiness lies in securing his particular order. But you

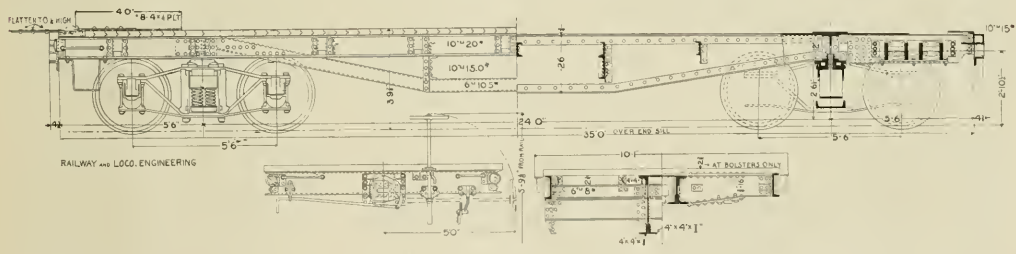

STRUCTURAL STEEL FLAT CAR FOR THE PANAMA RAILROAD, BUILT BY THE STANDARD STEEL CAR CO. OF PITTSBURGH.

Described on page 38 of the January issue.

from its central position. By using port marks to indicate where your valve is, you make the operation visible, hence know just what you are doing and guesswork is almost entirely done away with. A broken valve or seat is easily distinguished from a leaky valve from the volume and sound of the blow, and the points at which they occur. This method will also help to distinguish between valve and piston packing blows, since if there is a blow when your valve is covering steam ports you know it is the valve. It may be both, so go right ahead, and with throttle open move valve so as to open alternately back and front ports.

is emptied. This leak will be found somewhere between brake valve and equalizing reservoir or between brake valve and black hand of air gauge. Locate it by having full pressure, and, using lighted torch, passing flame along pipes, joints, unions, etc., until found. Then tell the repair man "what and where" the trouble is, and he and "all his kind," as well as the master mechanic, "will rise up and call you blessed." This is such a common defect and so few seem to fully understand the cause, I have felt that the explanation may be profitable.

WM. WESTERFIELD.

Mt. Carmel, Ill.

let one of these dead-in-earnest boys happen along, and the first thing you know he's persuaded the heirress that he loves her for herself alone or has eloped from town with an order for a carload of lard.

A lot of young men start off in business with an idea that they must arm themselves with the same sort of weapons that their competitors carry. There's nothing in it. Fighting the devil with fire is all foolishness, because that's the one weapon with which he's more expert than any one else. I usually find that it's pretty good policy to oppose suspicion with candor, foxi-

ness with openness, indifference with earnestness. When you deal squarely with a crooked man you scare him to death, because he thinks you're springing some new and extra-deep game on him.

It may have been the case once that when you opened up a bottle for a customer he opened up his heart, but booze is a mighty poor salesman nowadays. It takes more than a corkscrew to draw out a merchant's order. Most of the men who mixed their business and their drinks have failed, and the new owners take their business straight. Of course, some one has to pay for the drinks that a drummer sets up. The drummer can't afford it on his salary; the house isn't really in the hospitality business; so, in the end, the buyer always stands treat. He may not see it in his bill for goods, but it's there, and the smart ones have caught on to it.

After office hours, the number of drinks a fellow takes may make a difference in the result to his employer, but during business hours the effect of one is usually as bad as half a dozen. A buyer who drinks hates a whisky breath when he hasn't got one himself, and a fellow who doesn't drink never bothers to discover whether he's being talked to by a simple or a compound breath. He knows that some men who drink are unreliable, and that unreliable men are apt to represent unreliable houses and to sell unreliable goods, and he hasn't the time or the inclination to stop and find out that this particular salesman has simply had a mild snort as an appetizer and a gentle soother as a digester. So he doesn't get an order, and the house gets a black eye.—*Gordon Graham's Letters to His Son.*

#### One Sided Responsibility.

The safety appliance law seems to be in everybody's mouth at present, particularly when an accident occurs. Did it ever strike any of the brothers as strange that a locomotive engineer is seldom questioned in regard to the best signals on a railroad, or appliances on the engine itself, for the safety of employees and public? We recently had a very disastrous rear-end collision in the East that could have been avoided by the use of a cab signal in plain sight of the engineer. In places where there is heavy fog it is impossible to see more than 200 or 300 feet; very often not that far, and it is next to impossible to see a semaphore until the engine is right on it. A cab signal can be seen at all times.

The builders of locomotives are also assisting us to pay insurance to our members. Note the location of whistles, pops, injectors, gauge cocks and lubricators. How many men have been made sick by open and leaky overflows, leaky

gauge cocks stuck up under their nose on a Mother Hubbard or deckless engine, or the infernal rack&t made by one of those modern cannon denominated an injector and stuck within three feet of a person's head? The new fashion is to put the whole mess on the boiler head, checks and all, so as to thoroughly cook the poor crew in case of accident. No wonder a person loses eyesight or hearing, working in noise and steam when cocks leak. How many engines are running to-day with tight valve stem or piston packing? I never saw so many leaks with fiber packing and we had to "plug 'em" to hold engine and train, too. The old Friedmann injector was best located of any to take the noise

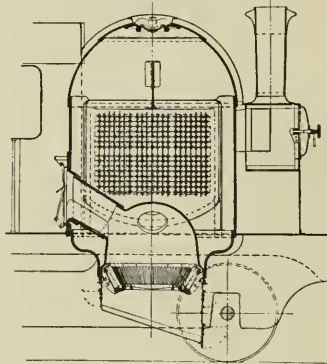

BOILER OF COCHRAN'S MOTOR.

away from the cab. Why do we need a lifting injector when a non-lifter will do better?

The B. of L. E. should take up the location of signals, cab fixtures, etc., and try to make things convenient as well as safe, for a man is given but one set each of eyes and ears.—James E. Magonal, in *L. E. Journal.*

#### Pass Stringency Double-Edged.

The scarcity of free railroad passes and of complimentary transportation that has ushered in the year 1906 is keeping many people very unhappy, and there is a disposition to retaliate where possible. An amusing manifestation of this spirit is seen in a press dispatch from Chicago to the *New York Sun*, which reads:

The railroad men are being treated to some anti-pass medicine and they find it bitter.

For years one of the most cherished perquisites of passenger officials has been a place at the head of theatrical "free lists." From the head of the passenger department down to the messenger boy in the city ticket office they got passes to theaters almost without limit. Even the vice-presidents had the

best seats at the best shows without dispensing cash; but it's different now.

On the first of the year the railroads informed the theatrical men that in future they could not give them any favors.

The theatrical managers held a conference and agreed to deal with the railroads on the same basis.

When a certain general passenger agent sent a messenger to a local theater one day last week with a request for four tickets for Saturday night, the answer received was: "We have adopted an anti-pass rule, and hereafter cannot give any free or reduced rate tickets."

This new rule of the theaters was the basis of a pathetic session of the special committee of the Central Passenger Association appointed to prevent anybody from getting railroad passes or reduced rates.

#### Rail Motor Carriage.

BY A. F. SINCLAIR.

Some months ago I mentioned a movement which is making rapid progress on British railways in favor of single cars with steam or other motor, with or without trailers, for short distance railway service. Scarcely a week passes without an announcement appearing of some further addition to this form of service, on one or other of the railways in England. The Scottish companies have shown extremely little enterprise in this direction, and this notwithstanding the fact that around Glasgow especially there are strong reasons in favor of the most modern and up to date methods being employed with the object of coping with the competition of the municipal tramways. But the Scottish companies generally have taken it lying down, and by gradually reducing their train services have shown their incapacity to meet the occasion. In England more enterprise has been shown, and at least one Scottish railway, the Great North of Scotland Company, have risen to the occasion. By the institution of both road and rail motor services this company have shown a laudable example to larger concerns. This company have in use two of these cars as shown. The car is so constructed that one end is carried on a pivot piece under the footplate of the engine. This piece sits in a movable bolster, moving between sliding faces and resting on springs, and as the whole is carried on two knife edges, easy riding at the engine end is obtained. The other end is carried on a well sprung bogie, and the comfort of the passengers in that matter is satisfactory. The engine can be readily detached from the car body.

The cylinders are 10 ins. in diameter and have a 16 in. stroke, the valves work-

traffic if need be and locomotive engines and railroad cars can be run over it as occasion may demand.

The towns of Binghamton and Corning will be connected by the new line and the intermediate towns of Union, Owego, Southboro, Waverly, Chemung, Elmira and Horse Heads will be included along the route. It is known that several independent electric lines have been projected for the purpose of doing business in this territory and the Erie Railroad intends by this move to forestall any outside enterprise in the "sphere of influence" which is regarded as properly its own.

#### Uncomfortable Envy.

Many of us miss the joys that might be ours by keeping our eyes fixed on those of other people. No one can enjoy his own opportunities for happiness while he is envious of another's. Life has its full measure of happiness for every one of us, if we would only determine to make the very most of every opportunity that comes our way, instead of longing for the things that come our neighbor's way.

We all know the man who makes himself miserable because he cannot get the engine some other man is running, or the position filled by some one else. He would be no happier if he obtained the engine or the position, but would merely regard with renewed envy something else that was out of his reach. The chronically envious person is one of the most contemptible reptiles that moves to cause general discomfort.

#### Horse Power and Thermal Units.

Our engraving shows a structural steel flat car built for the Isthmian Canal by the Standard Steel Car Co. This car was described on page 38 of the January, 1906, issue of RAILWAY AND LOCOMOTIVE ENGINEERING. The car is a 100,000-lb. capacity flat and weighs itself just 33,000 lbs. The tare of this car leads us to say that it can be made to illustrate very clearly what a horse power is.

Work, in the mathematical sense, is pressure acting through distance, but when we come to the idea of power we find that the time element has been introduced. This car weighs just 33,000 lbs., and if it was lifted bodily off the track for a distance of one foot, it would constitute work in the mathematical sense, but if the raising of this car one foot high was accomplished in one minute of time, it would require the expenditure of one horse power. The horse power is therefore 33,000 foot pounds delivered in one minute. Any other combination of pressure distance and time, which will give this product, is a horse power. Thus, 550 foot pounds per second is also a horse power. The

drawing of this car along a level track would probably not require a pull of more than a few pounds, and it must be remembered that the amount required to haul it and to lift it are two very different things.

The mechanical equivalent of heat has been established as 778.3 foot pounds. That means that the quantity of heat which is required to raise one pound of pure distilled water at its maximum density of 39° F. up to 40° F., or through this one degree, would, if expended in the form of mechanical energy, be capable of raising a weight of 778.3 lbs. through a distance of 1 foot against the action of gravity. The quantity of heat which is used to do this work is called one British Thermal Unit and is generally written B. T. U.

We have seen that the raising of this Isthmian Canal flat weighing 33,000 lbs. one foot high in one minute would constitute a horse power, and if we want

and it is, in substance, What is the relative cost of railway operation by steam power as compared with electricity?

This question cannot be answered definitely, and the time honored adage, "Circumstances alters cases," applies here with considerable force. In order to correctly estimate the comparative cost of these two sources of motive power one would require to be fully informed as to the conditions which prevail on the road in question. The cost of steam power has no definite relation to the cost of electrical power, and the ratio existing between the two can only be found for a particular road when its own set of local conditions are stated.

There are many roads in this country to-day which are more economically operated by the use of steam locomotives than they could be if electrical power were used, and there are others again where electricity would be an advantage. The only way for the authorities of the

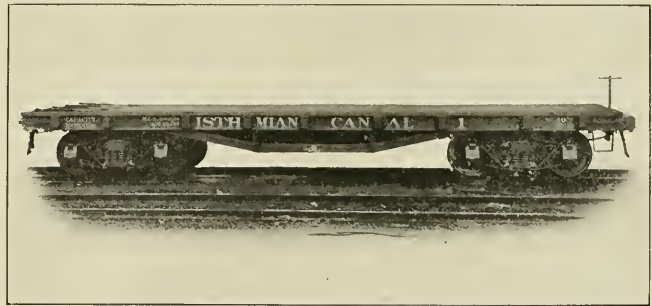

STANDARD STEEL CAR CO. FLAT CAR FOR THE CANAL. WEIGHS 33,000 POUNDS.

to do the same thing by the aid of heat units we would have to deliver 42.4 B. T. U. in one minute.

If a kettle on the stove contains one pound of pure water at a temperature of 60° F., and it is heated up to 212° F. in one minute, or, in other words, is brought to the boil, it will approximately have received 152 B. T. U. in that time. This amount of energy, if turned into mechanical work in one minute, would be capable of exerting over 3½ h.p., or it would lift the Isthmian Canal flat something over 3½ ft. high.

#### Circumstances Alter Cases.

Mauritius, or Isle of France, is a small bit of the British Empire situated in the Indian ocean. It is an island of about 706 square miles, lying off the west coast of Madagascar, and it has a population of something like 378,000. From Mauritius to New York is a long distance, yet an inquiry originating in that distant isle of the sea has found its way into the office of RAILWAY AND LOCOMOTIVE ENGINEERING. We have been asked a question which concerns more people than the dwellers in Mauritius,

road with whom the inquiry emanated is to state the conditions of track, grade alignment, distances between stations, weight of rolling equipment, character and amount of traffic at the present time, and also the reasonable expectations for the future, the location of water supply and fuel, and the position and volume of water power, if such exists, and any special conditions which do not readily present themselves in a general view of the case.

If these facts were presented to a company whose specialty was the equipment of electric roads, they would be able to offer some reliable figures on the cost of electrification and the subsequent operating expenses for the road in question. In general, one is always forced to the conclusion stated broadly that the successful use of electric traction on a designated road in the State of New York would not necessarily be a guarantee for the economical handling of a totally different road in the State of Pennsylvania. The figures covering, say, the one-time steam operated elevated roads in this city could not satisfactorily be applied to the railroads in Mauritius.

# Railway and Locomotive Engineering

A Practical Journal of Railway Motive Power and Rolling Stock.

Published Monthly by

ANGUS SINCLAIR CO.,

136 Liberty Street, New York.

Telephone, 984 Cortlandt.

Cable address, "Loceng," N. Y.

Glasgow "Locauto."

## Business Department:

ANGUS SINCLAIR, President.  
FRED M. WELLS, Vice-President.  
JAMES R. PATERSON, Sec'y and Treas.

## Editorial Department:

ANGUS SINCLAIR, Editor.  
GEO. S. HODGINS,  
JAMES KENNEDY, } Associate Editors.  
J. P. KELLY,

## Advertising Department:

Eastern Representative, S. I. CARPENTER, 170 Summer St., Boston, Mass.

## British Representative:

THE LOCOMOTIVE PUBLISHING CO. Ltd., Amen Corner, Paternoster Row, London, E. C.

## Glasgow Representative:

A. F. SINCLAIR, 15 Manor Road, Bellahouston, Glasgow.

## SUBSCRIPTION PRICE.

\$2.00 per year, \$1.00 for six months, postage paid in the United States, Canada and Mexico. For other parts of the world, \$2.50 or ten shillings. Single copies, 30 cents. Remit by Express Money Order, Draft, Post Office Order or Registered Letter. Mailing address can be changed as often as necessary—always give old and new address, and if you subscribed in a club, state who got it up. Please give prompt notice when your paper fails to reach you properly.

Entered at Post Office, New York, as Second-class mail matter.

Copyright by Angus Sinclair Co., 1906.

For Sale by Newsdealers Everywhere.

## Cash for Accident Prevention.

An up-state editor has formulated a scheme for preventing railroad accidents. He says nine out of ten probably occur from the carelessness of somebody, and his idea is to make that class of employees upon whose carefulness and good judgment the safety of others depends, pecuniarily interested in the success of their road as far as minimizing accidents is concerned.

To carry out this plan he suggests that a railroad company should make an appropriation, say at the beginning of each year, to cover the cost of probable accidents. An estimate of the amount required could readily be made by taking the average of the expenses thrust upon railroads by reason of accidents in the past. At the end of the year, if there had been no accidents, this fund would be intact and should be divided up among the class of employees who were responsible for the good record. If sev-

eral accidents had depleted this fund, the class referred to would receive less money per man, and if the year's record had been very bad they would not receive anything. The fundamental idea in this plan is that safety should be made to have a dollar and cent value to the railroad employee. The idea itself is not bad, but as the scheme here outlined stands, the railroad company would have to pay out a certain sum each year, applied either in defraying accident expenses or in rewarding their men. From the corporation's point of view it would on the average be just as expensive to have a good year as a bad one, for the accident fund would be all paid out in either event. If, however, the disaster account exceeded the accident appropriation the company would have a larger disbursement to face.

It may be argued that even if the company paid out the whole of the accident fund as rewards to their employees, the road would gain in reputation which would favorably affect its receipts and it would receive a good deal of free advertising, besides securing a highly efficient operating force, and all this might be cheaper and certainly would be better than if the fund (and in bad years something more) had been paid out simply to cover accident losses. The fund would thus become, in a certain sense, the premium on a sort of accident insurance policy held by the road for itself. The idea underlying this suggestion need not be cast aside as wholly valueless, because the details have not been fully worked out. Any sensible plan to reduce the loss of human life in railway operation is worthy of careful consideration.

A second part of the scheme is for the company to provide locked boxes at convenient places into which all employees should be requested to drop, signed or unsigned, information and suggestions calculated to prevent accidents.

This plan might work all right, but its success would depend largely on the good faith of the employees and upon the good judgment of the officials of the road. It would be possible, if unwisely handled, for the locked box communications to degenerate into a system of petty anonymous reporting and stabbing in the back, which would do no real good and yet keep the whole road in a ferment of discontent and uneasiness. If carried out in a manly and straightforward way on both sides, it might often put the officials in possession of valuable information. It would also give an employee the opportunity of making a good suggestion which would reach the men capable of directly dealing with it, and without everybody becoming cognizant of his idea, while it was in the embryo state.

In the meantime, and before the locked box has become a reality, the columns of RAILWAY AND LOCOMOTIVE ENGINEERING are open to railroad employees of all ranks who have something worth saying on this or kindred subjects.

## Favors Uniform Boiler Temperature.

The care of locomotive boilers is such a very important function that any information which is likely to make the performance of the duty more efficient is naturally received with the keenest interest. Mr. M. E. Wells, traveling master mechanic of the Wheeling & Lake Erie has evidently made a special study of the diseases and remedies of locomotive boilers, for he has presented several papers on the subject to railroad clubs, and one recently submitted through the Western Railway Club on The Care of Locomotive Boilers is particularly worthy of attentive study.

In the course of his business, Mr. Wells encountered the old, old trouble of leaky tubes, and a remedy being demanded he proceeded to work on the theory that all boiler leaks were caused by abuses in the roundhouse and on the clinker pit. To prove his theory, he determined to stay with a certain engine, and in doing so became convinced that the injected feed water had something to do with it. He found by working with the crew of that engine that the less feed water put into that boiler after it arrived at the terminal, the more likely they were to get into the house with the tubes dry. This brought him to investigating the temperature of the locomotive boilers under various conditions. By applying thermometers to different parts of boilers he discovered that the heat inside was far from being uniform, and to the strains resulting from this want of uniformity he attributes much of the leakage which is so troublesome to locomotive men. The want of uniformity of boiler temperature he attributes largely to the methods of boiler feeding and to the feed delivery appliances.

While pursuing his investigations Mr. Wells became convinced that the old time practice of using feed pumps was better than using injectors because feeding could be done only when the engine was moving. Following this line of thought he said:

"You cannot put water into a boiler for 15 seconds with the ordinary check arrangement with no feed water arrangement in there at all, without cooling the bottom tubes a little, according to the amount you put in and the condition of your fire, also according to whether your bottom tubes are open; all these things govern and affect it. I can sit on the seat box and pretty



nearly tell whether or not the tubes are stopped up. If the tubes are all open you can pump her more, at stations, and if the tubes are all open it warms the water up, as it goes in. The water goes into a boiler about 238 degrees colder than the water in the boiler, and if you don't add 238 degrees of heat to every bit of water, as it goes in, you get this bad condition. The cold water will slide down there and the steam gauge won't tell you much about it; but if you don't add this heat to this water as it goes in, then you will not maintain this water at uniform temperature, and if you do it you will have to add some more fuel. I fooled myself for years filling up with the throttle shut off. I thought I was saving fuel, filling up with the throttle shut off. You can't get something for nothing. You have got to warm that water. If you don't warm it before it goes in you have got to warm it up after it goes in. One of the most interesting things on an engine is to shut the water off, when you shut the throttle off, and when you pull out see the steam gauge stay up and drop back. That is what the pump used to do. What we are asking the enginemen to do with the injectors is to put the water in the boiler about as it went in with the pump, and we can demonstrate to any engine crew that it will save them leaky tubes."

The remedy recommended by Mr. Wells for leaky boilers was the making of efforts to maintain the boiler temperature as uniform as possible, feeding only when the engine was working being much insisted on. In this connection it is interesting to note recommendations made in Locomotive Engine Running and Management, by August Sinclair, published twenty-two years ago. Under the heading of Feeding the Boiler while working hard, Mr. Sinclair wrote:

"On a heavy grade one injector will not supply all the water necessary for steam-making, and the other is put to work. This is generally done when the slow, heavy pull begins and the steam reaches near to the blowing-off point. During the remainder of the ascent, the water is supplied as liberally as it can be carried; and the top of the grade finds the engine with a full boiler. This enables the engineer to preserve a tolerably even boiler temperature; for in running down the long descent which follows, where the engine runs several miles without working steam, the injectors can be shut off, and sudden cooling of the boiler avoided. The preservation of flues and fire box sheets depends very much upon the manner of feeding the water. Some men are intensely careless in this matter. In climbing a grade, they let the water run down till there is scarcely

enough left to cover the crown sheet when they reach the summit. Then they dash on the feed, and plunge cold water into the hot boiler, which is then peculiarly liable to be easily cooled down, owing to the limited quantity of hot water it contains. The fact of having the steam shut off, greatly aggravates the evil; for there is then no intensity of heat passing through the flues to counteract the chilling effect of the feed-water. If it is necessary to feed while running with the steam shut off, the blower should be kept going; which will, in some measure, prevent the change of temperature from being dangerously sudden. There will probably be some loss from steam blowing off, but this is the smaller of two evils.

"Engineers are not likely to feed the boiler too lavishly when working hard, for the injection of cold water instantly shows its effect by reducing the steam pressure. But this is not the case when running with the throttle closed. The circulation in the boiler is then so sluggish, that the temperature of the water may be reduced many degrees, while the steam continues to show its highest pressure.

"Writers on physical science tell us that the temperature of water and steam in a boiler is always the same, and varies according to pressure; that, at the atmosphere's pressure, water boils at 212 degrees, and produces steam of the same temperature. At 10 lbs. above the atmospheric pressure, the water will not evaporate into steam until it has reached a temperature of 240 degrees, and so on; as the pressure increases, the temperature of water and steam rises. But under all circumstances, while the water and steam remain in the same vessel, their temperature is the same. This is an acknowledged law of physical science; yet every locomotive engineer of reflection, who has run on a hilly road, knows that circumstances daily happen where the law does not hold good.

"A case where the conservative effect of careful firing and feeding was strikingly illustrated once came under the author's notice. During the busiest part of the season, the fire box of a freight engine belonging to a western road became so leaky that the engine was really unfit for service. Engines, like individuals, soon lose their reputation if they fail to perform their required duties for any length of time. This engine, '29,' soon became the aversion of trainmen. The loquacious brakeman, who can instruct every railroad man how to conduct his business, but is lame respecting his own work, got presently to making big stories out of the amazing quantity of water and coal that '29' could get away with, and how many trains she would hold in the

course of a trip. The road was suffering from a plethora of freight and extreme scarcity of engines; and on this account the management was reluctant to take this weakling into the shop. So the master mechanic turned '29' over to Engineer Macleay, who was running on a branch where delays were not likely to hold many trains. Mac deliberated about taking his 'time' in preference to the engine, which others had rejected, but finally concluded to give the bad one a fair trial. The first trip convinced the somewhat observant engineer that the tender fire box was peculiarly susceptible to the free use of the pump, and to sudden changes of the fire's intensity of heat. So he directed the fireman to fire as evenly as possible, never to permit the grates to get bare enough to let cold air pass through, to keep the door closed except when firing, to avoid violent shaking of the grates, and never to throw more than two or three shovelfuls of coal into the fire box at one time. His own method was, to feed with persistent regularity, to go twice over heavy parts of the division in preference to distressing the engine by letting the water get low, and then filling up rapidly. This system soon began to tell on the improved condition of the fire box. The result was that within a month after taking the engine, Mac was pulling full trains on time; and this he continued to do for five months, till it was found convenient to take the engine in for rebuilding."

Mr. Wells maintains that permitting cold air to strike the tubes or fire box sheets through the open door or through an open dump grate is not so likely to cause leakage as the difference of temperature inside the boiler. We doubt this. At 200 lbs. gauge pressure the heat of the steam or water inside the boiler is 388° Fahr. Feed water may be delivered at about 150°, making a difference of about 238°, but it will not get back to the flue sheet at any such temperature, so 200° difference may be considered a fair estimate.

Now, let us watch the work of the fireman and of the fire dumper. The engine is working hard with a fire box temperature close to 300°, and a sudden call for shutting off steam comes and the fireman jerks open the fire door, letting air that probably gets heated to 300° strike sheets and tubes. There is a roaring fire in the furnace when the clinker pit is reached and the fire cleaner drops the dump grate and starts the blower at its fullest blast. A sudden change of temperature to steel produces strenuous effects, no matter whether the change is caused by cold air or by cold water. The water will make more persistent cooling than the air, because it has greater capacity for cooling than the lighter medium, but

the extreme is very decidedly with the air.

#### Standard Machine Screws.

At the December meeting of the Society of Mechanical Engineers, held in New York, a committee entrusted with the consideration of a standard for the proportions for machine screws presented their report. The Sellers or U. S. form of thread having an inclined angle of 60 degrees, and a truncated or flat portion at the top and bottom of the thread was recommended as the basic standard. In machine screws the form is slightly changed to one-eighth of the pitch at the top and one-sixteenth of the pitch at the bottom. All diameters are to be expressed in decimals. A system of gauges was adopted to represent the size of a threaded tap before being fluted, each standard gauge to be stamped in decimals. The changes suggested are unimportant except in the matter of decimals, and we doubt whether the working machinist will take kindly to .4375 instead of  $\frac{7}{16}$ . Life is too short to waste it in recutting long decimals like .84375 when  $\frac{27}{32}$  would suit.

As the A. M. S. M. E. never go beyond recommending standards, the machine screw matter is not altered in any way.

#### Aluminum.

Scientists assert that the iron age cannot last longer than two or three centuries more. The demand for iron is increasing while the supply is necessarily diminishing. The present generation need not lose any sleep worrying over the subject. Out of the grosser elements of the earth there will always undoubtedly be found all the materials necessary for the requirements of the ages to come. It is already practically demonstrated that aluminum is much more plentiful than any other metal, and the difficulties that have hitherto attended the gathering together of the myriad metallic molecules out of the particles of silicon in the common clay where it is embedded are being gradually overcome, and new methods of the application of the forces of electricity are already causing a sudden segregation of the elusive atoms with the probable result that aluminum may soon serve the needs that are now supplied by iron and copper.

Aluminum is much lighter, and, in proportion to its weight, stronger than iron. It is about three times lighter than steel, and with a tensile strength of 28,000 lbs. it has about the same resistance to lateral strain as cast iron. Under transverse stress it is not a very rigid metal. It melts at 1,300° Fahrenheit and can be readily welded. It is very malleable and ductile. It loses little or nothing by oxidation. It has

been found very suitable for surgical instruments on account of withstanding the action of organic secretions. As an alloy it adds great strength and ductility to bronze. Ten or twelve ounces of this metal put into a ton of steel adds to the fine finish of the metal, and in many ways and uses aluminum is already meeting the increasing multiplex demands of advancing civilization.

#### Steamship "Carmania."

The success attending the first trip of the new triple screw, turbine driven, Cunard steamship "Carmania," which arrived in New York last month, marks a new era in ocean travel. It is the crowning of a long series of experiments undertaken to ensure absolute reliability. This ship has the highest development yet reached in any system of marine propulsion. It has at once demonstrated the superiority of the turbine engine in marine service. The "Caronia," a sister ship of the same size, equipped with the ordinary reciprocating machinery, had reached the highest previous record, but in point of economy of coal and water, and in the rate of speed, and in facility of turning, the result furnishes an immediate decision in favor of the turbine engines. The average gain is about five per cent., while in degree of vibration the new ship is literally motionless.

The Cunard Company have shown great enterprise and courage in fitting turbine engines to one of these great ships, and it is a matter of general regret that Lord Imeerlyde, who died recently, did not live to see the success of the great step which he inaugurated. Successful experiments had been made with much smaller vessels, the largest turbine previously used in one of the Allan line of steamers weighing 78 tons, whereas the low pressure turbine on the "Carmania" weighs 340 tons. Some idea of the vastness of these ships can be gained by learning that 12,000 tons of steel are used in their construction; most of it in plates 32 ft. in length, by 5½ ft. in width and 1½ ins. in thickness. The ships are 672 ft. in length by 72 ft. in breadth, with a depth from the main deck to the keel of 52 ft. The officers and crew number 710. The ships furnish accommodation for nearly 4,000 passengers.

The turbine engines of the "Carmania" may be described as three revolving drums 11 ft. in diameter by 8½ ft. in length, made of cast steel 2½ ins. in thickness. These drums are fitted with 1,115,000 blades, upon which the steam acts, causing the drum to revolve. These blades are fitted with the greatest degree of exactness, as the perfect balancing of the rotors is essential to avoid vibration. The drums are attached to the central shaft by dished wheels enclosing the ends of the drum, the wheels being keyed to

the main shafts, which are attached by sections to the three propellers. Two other ships are being built for the Cunard line, and they will be fitted with four turbines each, and a speed of over twenty-five miles an hour is expected from them.

#### Concerning Questions and Answers.

Our Department of Questions and Answers is an important one, as may be seen in this issue. We would urge on our correspondents to be explicit in their statements of conditions surrounding the problems they submit to us. Some of them remind us of an engineer who complained to us that he could not get his train away from the station. He, forgot, or he did not care to tell us, how he managed to get there. Accompanying data are of the utmost importance. In the present list of questions there are two in regard to the horse power of engines. The piston speed is not given, and we merely guess at a train velocity of twenty miles an hour. Possibly this is too high a speed for a heavy switching engine.

We take the opportunity to remind our correspondents who favor us with questions that they should not look for answers by return mail. We prefer, except in rare cases, to answer through our columns, so that the general reader may share the benefit of such information as may come through this source. We invite questions on all subjects pertaining to railway and locomotive engineering, and ask that our correspondents exercise a little patience in the expectation of answers.

#### Increase of Wages.

The new year has brought an increase of wages and a shortening of the hours of labor to the employees of the Interborough Rapid Transit Co. of New York. This is good news at all times, and especially to men who live in large cities where the price of commodities has increased much faster than the rate of wages. We have had assurances that an increase of wages would have been made at a much earlier date but for the ill-advised strike of the employees a year ago. There is always much more to be gained by appealing to the moral sense of the management than by engaging in stupid attempts at crushing a great corporation.

Mr. Frank Hedley, the general manager, has always shown a kindly disposition toward the employees, and recently reinstated a number of old employees who had learned by bitter experience that it is no light thing to give up the occupation of a lifetime and begin to look for new employment. Men who have passed the meridian of life should think twice before placing themselves

outside of the employment in which they have grown up, and the lesson learned by the employees of the Interborough roads will not soon be forgotten.

#### Quid pro Quo.

In dealing with the tendency to go to extremes in the anti-pass crusade, the *New York Commercial* quotes an executive officer of one of the eastern lines, who, when spoken to about refusing the exchange of courtesies between newspapers and railroads, said:

"I am not, and never have been, in sympathy with the cutting off of newspapers, as has been done by some roads. There is no call for it, and the action is beyond the demands involved. As between the railroads and the newspapers, it is a fair exchange—a trade in which the money consideration may be artificial, but it is there, just the same, with the balance, as a rule, very largely in favor of the railroads. They get more than they give, because the newspapers are so constantly doing for them so much that is unsolicited, but often exceedingly welcome, sometimes saving or giving to the roads what is equivalent to thousands of dollars—according to them what money cannot buy, and benefits very valuable to properties and profitable to the companies. For this reason our people are disposed to make the most liberal exchange contracts possible."

#### Book Notices.

Gas, Gasoline and Oil Engines. By Gardner D. Hiscox, M.E. Published by the Norman W. Henley Publishing Company, New York, 1905. Price, \$2.50.

This book is now in its fifteenth edition and has been revised and considerably enlarged. It treats in a very comprehensive way of the construction, installation, operation and maintenance of gas, gasoline and crude petroleum engines as manufactured in this country. It takes in the subject of explosive motors for stationary, marine and vehicle power, and shows illustrations of parts and tabulated sizes and gives instructions as to the care and running of these machines.

Electrical ignition as secured by induction coil or by jump spark is explained and illustrated, with information on economy and power tests and also on the erection of power plants. The subject of producer and suction gases is handled in a way that cannot fail to be a great help to those interested in this branch of the subject. A valuable feature of the book is that it gives in full the rules and regulations of the Board of Fire Underwriters as regards the installation and management of gasoline engines, and

it also contains suggestions on the safe installation of explosive motive power. The book closes with a list of the leading gas and oil engine manufacturers of the United States and Canada, and, what is more, their addresses are given. There is also a list of U. S. patents issued on gas, gasoline and oil engines and their adjuncts. This is complete from 1875 to the present time. The book also contains a comprehensive index alphabetically arranged.

Practical Pattern Making, by F. W. Barrows. Published by the Norman W. Henley Publishing Company, New York, 1905. Price, \$2.00.

The author of this book is a pattern maker of thirty years' experience and the book is a practical treatise on the art of wood and metal pattern making.

#### Staten Island Rapid Transit Notes.

There are few railroad shops so finely situated as are the shops of the S. I. R. T. at Clifton, Staten Island. From the shop windows the Atlantic steamers can be seen passing and repassing. Battleships and pleasure yachts are anchored side by side, and blasts of music float over the shining waters.

Outside is a fairyland, but inside the mechanics are busy keeping the 36 locomotives in perfect trim for the growing traffic that is changing the quiet fields of Staten Island into a spreading city. Mr. J. H. Clark, the master mechanic, is an eastern man, a skilled engineer of wide experience. Since taking charge he has rebuilt five locomotives of a new type. They somewhat resemble the Forney type formerly used on

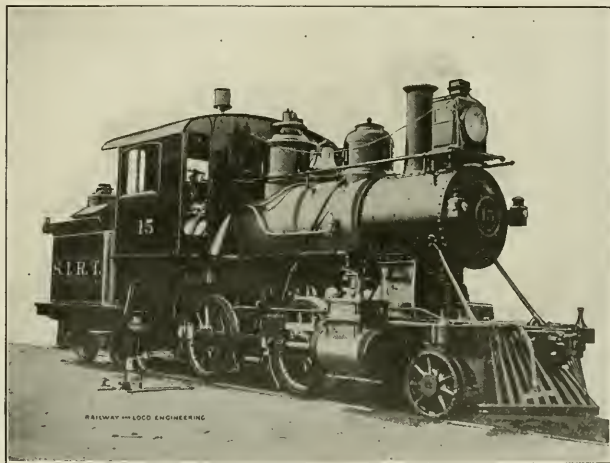

TYPE OF LOCOMOTIVE ON THE STATEN ISLAND RAPID TRANSIT R. R.

It has 325 pages and is fully illustrated throughout and has a good index. It contains a detailed description of the proper materials to use and the tools to fashion the pattern with.

A portion of the book is devoted to rules, formulas and tables, and it contains some simple and original directions for finding the weight of castings, both from the pattern and from the drawing. Some new and very practical formulas for estimating weights are given.

In the last part are to be found some good suggestions for keeping down the cost of making patterns and checking the cost. A system of making patterns is stated and a scheme for writing up a card record of patterns is also given. The book concludes with practical suggestions for keeping an inventory and valuation of patterns.

the New York elevated railroad, but are much heavier. They are fitted with wide fire boxes adapted for burning small coal, and some of them have saved their own price in coal already.

The accompanying illustration shows the general features of these engines. Their weight is about 96,000 lbs., the length, including tender, 38 ft., and height from rail to top of smokestack, 12 ft. 6 in. The diameter of the shell of the boiler is 45 ins., the fire box being 72 ins. in length, 66 ins. in width and 42½ ins. in height. There are 144 flues 2 ins. in diameter, and the boiler is adjusted to a working pressure of 160 lbs. The cylinders are 14 ins. by 22 ins., the valves being of the balanced Richardson type. The driving wheels are 50 ins. in diameter, 7 ft. from center to center. The locomotives are furnished with a double set of Eame's vacuum

brakes, and the engines have a tractive effort of over 11,000 lbs., and are altogether admirably adapted for suburban traffic.

We observed several clever devices in operation in the machine shop. In removing worn tires the rims are generally heated by gas jets, or open hearths, at considerable expense. Here the wheels are slightly raised by blocking up the axle, a double-flanged shield is fastened around the half of the tire, and at one end of the shield a jet of crude oil and a blast of compressed air is admitted. A torch is applied and with an adjustment of the oil and air valves a fierce flame encircles the wheel. In twenty minutes the tire was tapped off easily, and meanwhile an extra shield had been adjusted to the other tire and the operation went on without loss of time and at very small cost.

Driving boxes also, when worn laterally, are generally reinforced with plates held by countersunk tap bolts. Here the box was put in the lathe and a dovetailed recess was cut about four inches in width in the middle of which there was cut another smaller dovetailed recess. The box was then sent to the brass shop and the double recess filled with molten brass. When cool any shrinkage was readily made up by a few blows of a hammer and trimmed off in the lathe. The box is as good as new, not one of the added pieces has ever moved.

It may be added that in addition to the locomotives there are several tug-boats, 22 car floats, 3 steam lighters, besides extensive dock machinery which are all kept in repair at the company's works at Clifton.

#### Short Stop.

There is a man in the Wilmington, Del., shops of the Pennsylvania Railroad who believes in brakes. Oh, well, you say, that's nothing; the Westinghouse and the New York Air Brake people believe in brakes until further orders. Yes, but this man believes in hand brakes and the way that he shows it is beyond dispute.

He works on a Bett's horizontal boring mill which is driven by an electric motor mounted on the machine. Among other things, he bores driving box brasses, engine truck brasses and cellar edges, also rocker arm brasses, driver brake cylinders, driver brake fulcrums, stuffing boxes for valve stems when required, and other things too numerous to mention; and he believes in brakes.

His electric motor is a high speed affair, and when at work spins round with a merry hum while the mill revolves sedately at the required speed for the work in hand, and everything is lovely until it comes to making a stop. Even

then things continue to be as lovely as they are when in full blast.

Our illustration, sketched from life, by our own artist, as the daily papers say, shows that on the projecting end of the motor spindle, an 8 in. pulley with a  $1\frac{1}{4}$  in. face, has been keyed, and this little wheel turns as fast as the electric motor runs. Upon one side of the machine is bolted a simple upright bracket, the top of which is the fulcrum of a lever. One end of the lever is a handle, and the other bent into a curve to fit the little pulley, passes under it, and extends beyond. Its extreme end is weighted just sufficiently to keep the curved portion of the lever from rubbing on the 8 in. pulley. The curved part of the lever is shod with a piece of discarded leather belting and this is the device which makes the short stop.

When a piece of work is finished up in good workmanlike style, the power is shut off, but the motor keeps on spinning round with the stored up energy, which is sometimes called momentum. Left to itself the motor would make a

means of some advertising posters, a few rhyming verses and the moving-picture machine, a character which is quite as real as any which live in the pages of a novel.

Miss Phoebe Snow is a real person to us all, and the only reason why she is not on the payroll of the Lackawanna is because she ranks with the characters in fiction, and is only impersonated by the pretty artists' model, as an actor might impersonate Julius Cæsar or Henry V. If you want to see Miss Snow alive and going through her part you ought to take in some one of F. F. Proctor's four New York theaters and see her on a D., L. & W. train before the footlights.

Her latest appearance is in a series of very clever moving pictures, taken by what is called the Kinetograph department of the Edison Manufacturing Company, of New York. Each one of the series is preceded by a short explanatory verse. Miss Snow is, first of all, found riding in the cab of a fast express engine on the road of anthracite,

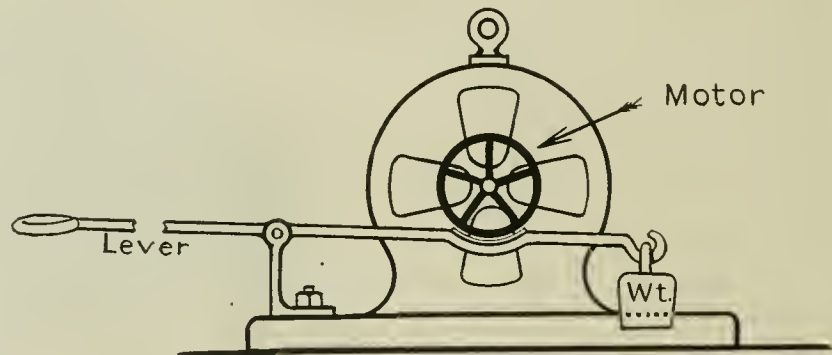

IMPROVISED HAND BRAKE ON ELECTRIC MOTOR.

good many turns after the current had been shut off, and the boring mill would revolve 19 useless times, although the tool had been withdrawn and the cut finished. This means a loss of time, and to a piece-work man that is intolerable. The application of the hand brake here described reduces the useless revolutions from 19 to less than one; in fact, to three-quarters of a turn, and the mill makes a short stop, and so time is saved and wear and tear reduced.

#### Creation of a Character.

When a famous writer makes you feel that you know some person quite as well as if he was alive and as if you were personally acquainted with him, the author is said to have created the character. Such a creation Dickens produced when he described the inimitable Sam Weller, and such a character Conan Doyle gave us when he told of the marvelous detective work of Sherlock Holmes. It has, however, been reserved for Mr. W. P. Colton to produce, by

and as the train sweeps by she waves her hand to the spectators in parquette and galleries. The next one shows the famous Delaware Water Gap, and Phoebe is seen in her smart white skirt and stylish hat, standing on the observation end of a parlor car. This scene is particularly good, the trees and foliage stand out with remarkable distinctness, while over all there is that peculiar blue tone of color which the shadows cast by moonlight always give. Following this is the dining car scene, where the fair traveler fares well on the fare provided by the Lackawanna. The last picture shows Miss Phoebe coming forward to greet the engineer who is "oiling round," and here there is no make-up and no fiction. By his gesture he says as plainly as words could say that he dare not soil her dainty glove with his oily hand, but Miss Snow is not to be put off in that way, and so the man of the throttle uses up a piece of the company's waste in the good cause and gives her a hearty and good-humored hand-shake.

# Our Correspondence School.

In this department we propose giving the information that will enable trainmen to pass the examinations they are subjected to before being promoted. If any of our students fail to understand any part of the instructions, we will gladly try to make them plainer if they write to us. All letters intended for Our Correspondence School ought to be addressed to Department E.

## Utilizing Our Educational Course.

In the course of a private letter, the superintendent of a well known railroad recently wrote to the editor of RAILWAY AND LOCOMOTIVE ENGINEERING:

"Referring to our recent conversation in regard to the educational class recently formed by our employees for the promotion of their welfare, and, incidentally, the company's. I beg to advise you that our employees are largely subscribers to your paper, and in getting hold of your first number that outlined the details of your correspondence school, it occurred to them that it would be a very good idea to form a class and use your instruction papers for the purpose of questions and answers and general information. The time that the class was formed, I was in the employ of this company as master mechanic, and the class asked me to act as instructor, which I did. We took your list of questions and began by asking question No. 1, and so on, getting an expression or answer from each member of the class, using your answers as authority.

"Personally, I can say that we obtained very gratifying results, and I was greatly surprised at the manner in which our men took up the subject. The class is still in existence and they are using your journal from month to month for this purpose. Our company is strongly supporting them in their efforts, and I feel that RAILWAY AND LOCOMOTIVE ENGINEERING has been a great benefit to both company and men, and I want to personally thank you for incorporating this feature in your paper.

"I am satisfied that every engineman and railway employee will be greatly benefited by studying this course. I also wish to thank you for the courtesies and kind wishes which you expressed to me at my last visit to your office, and to assure you that RAILWAY AND LOCOMOTIVE ENGINEERING, as well as all your publications, are well taken care of on our road."

## First Series—Continued.

41. What usually is the cause for steam being wasted from the safety valve?

A.—Injudicious firing, or want of co-operation between engineer and fireman.

42. What is the estimated waste of coal for each minute the safety valve is open?

A.—From 15 to 20 lbs.

A systematic test was made of an

engine with about 1,200 sq. ft. of heating surface and 27 sq. ft. of grate area to ascertain the volume of steam wasted through the safety valve. It was found to be 91 lbs. of water per minute. As each pound of coal burned will evaporate about 6 lbs. of water, the waste of coal in that case would be about 15 lbs. per minute.

43. What should be done to prevent waste of steam through the safety valves?

A.—The firing should be so regulated when the engine is working that the steam will not rise to the blowing-off point; when steam has to be shut off unexpectedly blowing off may be prevented by closing the dampers, opening the fire box door a little and keeping the injector going. The surplus steam may also be blown back into the water tank.

44. What should be the condition of the fire on arriving at a station where a stop is to be made?



AN OLD MAIN LINER NOW RELEGATED TO A BRANCH.

A.—Bright and clear, so that little smoke will flow from the stack. There must be sufficient fire on the grates to build on when the engine is started.

45. How should you build up the fire when at stations in order to avoid black smoke?

A.—By putting in small quantities of coal at a time at short intervals and permitting the charges to burn bright.

46. What should be the condition of the fire when passing over the summit of a long grade?

A.—It should be burned down as low as the requirements of steam making will permit.

47. If the injector is to be used after passing over summit, how should the fire be maintained?

A.—The fire ought to be maintained bright and the blower kept in use to create some circulation in the water of the boiler.

48. Is it advisable to take advantage of every opportunity to store in the boiler as much water as possible?

A.—It is.

49. Why is it that if there is a thin fire with a hole in it, the steam pressure will fall at once?

A.—Because cold air passes through the hole and has a chilling effect upon the boiler.

50. What would be the result of starting a heavy train with too thin a fire upon the grates?

A.—Delay for want of steam.

51. How deep a fire should be carried?

A.—It should be no deeper than necessary to make the required steam. The kind of fire box and the work to be done would influence the proper depth of fire.

52. Where should the coal, as a rule, be placed in the fire box?

A.—It ought to be placed evenly over the entire surface of the grates.

53. Is rapid firing advisable?

A.—No. Not the rapid firing that puts a heavy charge of fresh coal quickly into the fire box. The rapid action that puts a scoopful of coal where it belongs having the door open as short a time as possible is commendable.

54. When and for what purpose is the use of rake on the fire bed allowable?

A.—When the surface of the fire is coking so that combustion is obstructed.

55. Within what limits may steam pressure be allowed to vary, and why?

A.—When an engine is working the steam pressure ought to be kept as uniform as possible short of blowing off pressure. When approaching stations the steam pressure should be reduced sufficiently to prevent blowing off.

56. Is it advisable to raise steam rapidly?

A.—Not if it can be avoided without causing delay. Rapid raising of steam, especially from cold water, puts destructive strains upon the boiler sheets.

57. Has improper firing any tendency to cause tubes to leak? How?

A.—It has. Improper firing causes wide variations in the temperature of the fire box, and sudden reduction of temperature causes the tubes to contract and leak.

58. What would you consider abuse of a boiler?

A.—Intermittent firing, causing fluctuating variations of fire box temperature, cooling by means of an open fire box

door and intermittent boiler feeding. Feeding the boiler rapidly when steam is shut off abuses the boiler.

59. How would you take care of a boiler with leaky tubes or fire box?

A.—Maintain the temperature as evenly as possible by uniform firing and boiler feeding. I should avoid feeding when steam was shut off.

60. What are the advantages of an arch in the locomotive fire box?

A.—It tends to keep the temperature of the fire box uniform; it prevents cold air from passing directly into the tubes, and it lengthens the journey of the fire gases on their way to the tubes. The arch acts also to some extent as a spark arrester.

61. Why is it very important that coal should be broken so that it will not be larger than an ordinary sized apple, before being put into the fire box?

A.—Because in that condition it provides the best surface for ignition and provides the proper openings for emission and mixture of the fuel gases.

shake, and when should they be shaken?

A.—To break up the clinkers and ashes that close up the grate openings and restrict the supply of air. The grates should be shaken very lightly as soon as the fire shows that air is too much restricted. With some kinds of coal the grates must be moved frequently to prevent them from "sticking," a condition caused by fused clinker.

67. Why should grates not be shaken too frequently?

A.—Because good fuel would be wasted and the ash pan prematurely filled with danger of burning the grates.

68. Is it a fireman's duty to avoid filling up the ash pan too full?

A.—Certainly it is.

69. Is it permissible to dump ashes or fire over road crossings, switches or around stations?

A.—It is not.

70. Is it objectionable to fill the tanks too full or spill water at stand pipes or water tanks?

A.—It is a very objectionable and dan-

gerous practice, and should be avoided. (10) Inquirer, of Albuquerque, N. M., writes: Is it possible for an oil burning engine, running short of water and scorching crown sheet sufficiently to cause the loosening of several button head radial staybolts, to keep from leaking or show any signs of leaking until after engine reaches terminal and cooled down? Engine under pressure of 200 or 225 lbs. of steam. Claim is made that leak would not show up until contraction took place, the pressure holding sheet down to bolts in proper position. A.—We think it quite likely that leakage would not begin until the boiler cooled. One time that the writer was working a train along in heavy snow the engine began to prime water very quietly. When he noticed the water passing through the stack, the engineer pulled the injector full open, then jumped down and looked into the fire box, and found the crown sheet was red. Leakage of the crown bolts did not begin until the boiler cooled down.

#### HOT CROWN SHEET.

(10) Inquirer, of Albuquerque, N. M., writes:

Is it possible for an oil burning engine, running short of water and scorching crown sheet sufficiently to cause the loosening of several button head radial staybolts, to keep from leaking or show any signs of leaking until after engine reaches terminal and cooled down? Engine under pressure of 200 or 225 lbs. of steam. Claim is made that leak would not show up until contraction took place, the pressure holding sheet down to bolts in proper position. A.—We think it quite likely that leakage would not begin until the boiler cooled. One time that the writer was working a train along in heavy snow the engine began to prime water very quietly. When he noticed the water passing through the stack, the engineer pulled the injector full open, then jumped down and looked into the fire box, and found the crown sheet was red. Leakage of the crown bolts did not begin until the boiler cooled down.

#### LEAKING THROTTLE VALVE.

(11) F. R. U., of Seattle, Wash., writes:

I have had trouble with a leaking throttle valve. The night foreman says it must be the dry pipe joint. How can you tell without taking the pipes apart? A.—A leak in the throttle valve will always show dry steam, whereas a leak in the dry pipe will show more or less water, as it is near the water line. When an opportunity occurs the dry pipe can be entirely submerged in water, leaving the throttle valve dry, when a leak in the dry pipe will show water readily.

#### HEATED ECCENTRIC STRAP.

(12) W. T., of Burlington, Vt., writes:

The eccentric straps seem to be giving us more trouble than ever this winter. What is the best thing to do when a strap begins heating? A.—When you have a chance to stop the engine slacken the bolts holding the two parts of the eccentric strap together. Put in an extra tin liner or two, which you should have with you, but if not, stiff paper will do. Tighten the bolts again to avoid rattling, and oil the eccentric

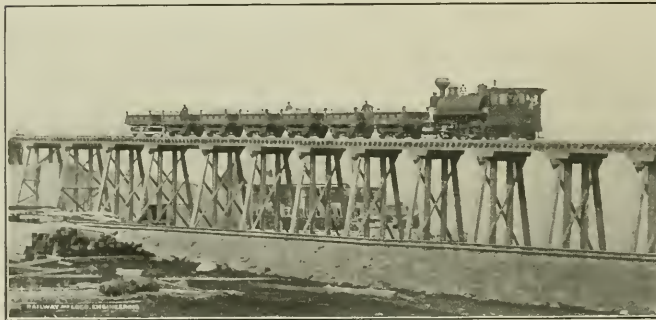

LIME ROCK RAILROAD, 0-4-2 ENGINE ON A TEMPORARY TRESTLE.

62. When and why should you wet the coal in the tender?

A.—As soon as the supply of coal has been put upon the tender. The wetting is done to keep down the dust. It also tends to keep the mass of fine coal together and prevents it from being drawn into the tubes by the suction of the exhaust.

63. Should coal be allowed to lie on the deck and fall out of the gangway?

A.—Certainly not.

64. Do you understand that the coal used on the locomotive is property and represents money invested by the company?

A.—I do.

65. What are the advantages of a large grate surface?

A.—It permits of slower combustion than would be practicable with smaller grate surface and slow combustion under proper restrictions promotes economy of fuel.

66. Why are the grates made to

gerous practice, and should be avoided.

71. What are the duties of a fireman on arriving at a terminal?

A.—The answer to this question will vary according to the rules of the particular road.

72. Is the engineer responsible for the fireman's conduct while on duty and the manner in which the fireman's duties are performed?

A.—He is.

### GENERAL

## Questions Answered

#### PISTON OR D-SLIDE VALVE.

(9) O. D. C., of Kingston, N. Y., writes:

Will you kindly tell me why it is that the Schenectady cross compound locomotives are built with a slide valve on low pressure cylinder and a piston valve

thoroughly, adding a good supply of graphite. If the eccentric straps are of cast iron, they should not be cooled with water. When a strap is heated it is safer to run the engine with the shortest possible stroke of the valve, the long stroke puts greater stress upon the valve straps.

#### VARIABLE SIZE OF OIL DROPS.

(13) W. K., of Omaha, Neb., writes: Will you kindly explain why some drops of oil are larger than others when fed through a lubricator? I notice when we feed one kind of oil the drops are small; while with other kinds fed through the same lubricator the drops are twice as large. A.—The variation in size of oil drops is due to the properties of the different oils, the greater the specific gravity or weight of an oil, the thicker it will be. The variation in size is influenced by both weight and thickness, heavy, thick oils producing large drops, and light, thin oils small drops. Heavy, thick oils are more sticky than thin oils and have a greater tendency to adhere to surrounding surfaces, and have a less tendency to rise through the column of water in the lubricator glass than do the drops from thick oils, and consequently grow larger before there is sufficient force developed to detach them from the lubricator feed plug.

#### DRIVING BOX CELLAR.

(14) J. M., of Scranton, Pa., writes: I was much interested in the story in your December issue of a conductor who showed an engineer how to take down an oil cellar. Please tell me the best way to lower a cellar of the ordinary kind, as I have had much trouble with several when the boxes were slightly heated, and it was necessary to repack the boxes. A.—A simple device can be made of two pieces of three-eighth round iron. The pieces are bent at one end so that they will enter nearly one inch into the bolt holes of the cellar. The other ends to be turned up as hooks to which a short piece of chain can readily be attached. A bar can then be put through the spokes of the wheel and the box pulled down as far as required.

#### SLIPPERY RAILS.

(15) J. G., of Long Island City, N. Y., writes:

Is it best to keep a small stream of sand running all the time on slippery rails, or to open the sand valve now and then? A.—Some engines are fitted with pneumatic sanders, and a fine stream of sand can be maintained without great loss of sand; but with common sand valves, such a fine flow is impossible, and fairly good results can be obtained by occasionally opening and shutting the valves. A certain amount

of sand will adhere to the wheels and aid the adhesion to the rails, and a short opening of the sand valve three or four times in a mile will help over the slipperiest track. It is a matter in which no exact rule can be given, one must be guided according to the conditions.

(16) J. R. P., of North Madison, Ind., writes:

1. What is the horse power of a locomotive weighing 143,000 lbs., cylinders 22x28 ins., driving wheels 50 ins. in diameter, 160 lbs. pressure, 8 wheels and all drivers? A.—At a velocity of 135 revolutions per minute, or 20 miles per hour, the locomotive will develop 960 h.p.

2. What is the horse power of a locomotive weighing 149,600 lbs., cylinders 20x24 ins., drivers 46 ins., 140 lbs. steam pressure, 8 wheels and all dri-

2. Would the pull on front drawbar of the second engine in any way affect the free movement of the engine truck that would be liable to cause derailment to second engine any more than if there was only one engine on the train? A.—The element of flexibility in a ten-wheel engine, that is, one with a four-wheel truck and six driving wheels, cannot in any way be disturbed by drawbar pull. A ten-wheel engine when poorly designed or with weight badly distributed is not a safe engine at high speeds. If there is too little weight on the truck it cannot guide the engine properly round curves or through switches, and there is liability to derailment. A double header, so called, is always much safer than trains having one engine in front and one behind. This can be illustrated by observing how readily a chain can be pulled in a straight line and how

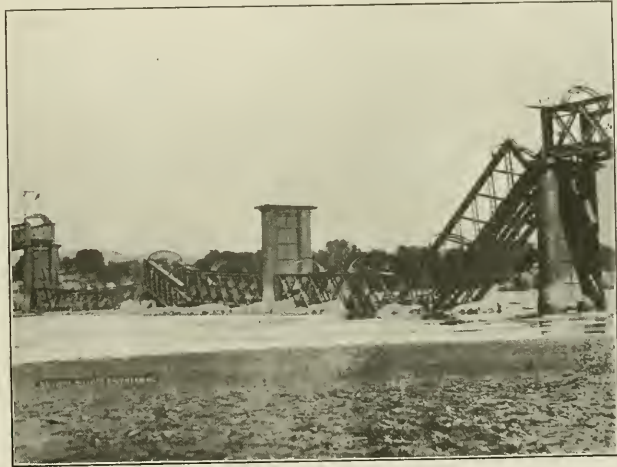

BRIDGE WRECKED BY DYNAMITE AT NORVAL'S POINT, SOUTH AFRICA.

vers? A.—At 20 miles an hour, or 146 revolutions per minute, the horse power would be 635.

The simplest and best methods of calculating horse power will be found at pages 285-293 in "Twentieth Century Locomotives," published by the Angus Sinclair Co.

(17) W. P., of Calgary, writes:

1. Is it considered good practice to double head 10-wheel engines weighing from 65 to 85 tons on passenger trains running at a speed of from 35 to 50 miles per hour? A.—The practice of double heading should be resorted to only under stress of necessity. Many occasions arise, especially during winter, when two engines are necessary to take a train through snow drifts. Under such conditions the speed is not generally maintained at the highest.

easily it will buckle if an attempt is made to push it. In all double headers the stronger engine should be in front and the two engine crews should be thoroughly in touch with each other, working the engines as harmoniously as possible.

#### BLOW IN CROSS COMPOUNDS.

(18) C. J. W., of Danville, Ill., writes:

Please give me a good way to locate a blow in a cross compound. A.—Blows in cross compounds are located the same as in simple engines except that steam from the starting valve must be used for the low pressure cylinder. To test for blows of valves or pistons, place the engine on the quarter and block the driving wheels. Place reverse lever in center notch, which will make the valve cover both points. Open the cylinder cocks and open the throttle a

little. If steam appears at the cylinder cocks, the valve on that side is leaking. To test the piston, move the reverse lever to full gear and apply steam. If the packing is blowing steam will blow out of both cylinder cocks. Test the other side of the engine in the same way. There is a difference in the sound of a piston packing and a valve blow that can readily be distinguished by a practiced ear. A valve leaks with a whistling sound, the piston with a subdued roar. Every fireman ought to have the engine tell him the difference in the two blows. The sound can best be heard when the furnace door is open.

#### HEAT WITHOUT LIGHT.

(19) Inquirer, of Kansas City, Mo., writes:

The books on combustion that I have read say that combustion is the uniting of two elements, carbon and oxygen, and that the combustion always produces light and heat. Something I read in RAILWAY AND LOCOMOTIVE ENGINEERING years ago makes me think that light is not always present in combustion. How is it? A.—In the rapid chemical action seen in an active fire, light and heat result, but there are instances of slow combustion where no light is produced. The rotting of wood is a species of slow combustion when no light is given out. The oxidation of various substances such as the rusting of iron produces heat without light. An interesting experiment to show combustion without light is to mix half a pound of powdered sulphur with the same weight of iron filings. Mix them well and put it in a hole in the ground. Cover it up well and pour on some water. Very soon the mass heats, raises up the earth and pours forth sulphurous vapor.

#### INJECTOR TROUBLE.

(20) J. R. B. writes:

What will cause a brand new Ohio injector not to prime with tank hose in good condition, strainer clean, and boiler checks in good condition? This injector came new with the engine from the locomotive works, and we have had the same trouble ever since the engine came here. I oiled injector and it did pretty fair for a few hours, then it won't prime at all or else we blow the steam back in the tank. A.—Assuming that there is plenty of water in the tank, that the tank valves are wide open and that the injector is located as low on the boiler as it is convenient to have it, we should attribute its failure to prime satisfactorily to one, or to several combined, of the following causes:

Leaky steam throttle; leaky tank hose connection, leaky connection between feed pipe and injector body. A leaky steam throttle will heat the water in

the feed pipe so that when an attempt is made to prime it, a vapor will rise from the surface of the hot water that will prevent a vacuum from being readily formed; a very slight air leak around the hose connections, provided the water is low in the tank, will often make it difficult for an injector to prime. But a slight leak at the union nut between the injector body and the feed pipe will almost always prove very annoying in the attempt to prime the injector, and because of its close proximity to the injector priming nozzle, will often make it almost impossible to do so. Injector nozzles not in line, loose or not properly proportioned will cause an injector to work badly.

#### BOILER EXPLOSIONS.

(21) J. B., of Altoona, Pa., writes:

Two recent boiler explosions occurred while the locomotives were standing still. Is there any extra danger in allowing boilers to stand for some time under a high pressure of steam? A.—It is a singular phenomenon that water that has been heated in a boiler and allowed to cool can be heated again considerably above the boiling point before ebullition or bubbling will take place. This superheated water will burst at once into a violent state of ebullition if the vessel containing it is subjected to a sudden shock. The experiment can be tried in the open air with water that has been boiled previously, and, when sufficiently heated, a sudden dip of the finger or other disturbance will start the water boiling with the suddenness of an explosion. In view of these facts the conclusions in regard to some boiler explosions are that the water in the boiler having become superheated, on the throttle valve being suddenly opened, the escaping steam causes a disturbance of the water resulting in a sudden ebullition and consequent increase of pressure, which, acting like a blow on the sheets, an explosion occurs at some weak section of the boiler where there may be a number of fractured stay bolts.

#### Electrification of St. Clair Tunnel.

The announcement has been given out by the Grand Trunk Railway System that arrangements have been made for the adoption of electric traction in the St. Clair Tunnel, the contract for which has been awarded to the Westinghouse Electric and Manufacturing Company; the work to be started at once and brought to completion as quickly as possible. The system that will be adopted is known as the alternating current system with overhead conductors—the conductors in the interior of the tunnel being placed upon the walls, and in the railway yards they will be supported by steel bridges. The

trains will be operated by alternating current locomotives, capable of hauling a passenger train on the grade at the rate of 20 to 25 miles an hour, and a freight train of 1,000 tons at the rate of ten miles an hour. The interior of the tunnel and the yards on both the United States and Canada sides of the St. Clair river will be lighted by electricity from the power that will be generated in the extensive power house that it will be necessary to erect.

The length of the tunnel proper is 6,025 ft., and of the open portals or approaches, 5,603 ft. additional, or more than two miles in all, one of the longest sub-marine tunnels in the world. It is a continuous iron tube, 19 ft. 10 ins. in diameter, put together in sections as the work of boring proceeded, and finally bolted together, the total weight of the iron aggregating 56,000,000 lbs.

The work was commenced in September, 1888, and it was opened for freight traffic in October, 1891; a little more than three years being required for its completion. Passenger trains began running through it December 7, 1891. It cost \$2,700,000.

#### Teaching by Mail.

Correspondence schools for the instruction of workmen and others engaged in daily labor have been remarkably successful, and are supplementing the school education of thousands of persons. When the instruction is so imparted that the student acquires knowledge likely to increase the value of his services, it is of the practical kind that readily appeals to people of common sense. When the instruction of a correspondence school, however, is so formulated and arranged that it proposes educating the student to be a teacher of the higher branches of the business taught, it is going over the heads of the multitude and only a very small percentage of those who enter the course will persist in following it to the end. A far reaching, comprehensive course of study is prepared so that a high price can be charged for the lessons.

We claim that the educational course given in RAILWAY AND LOCOMOTIVE ENGINEERING is more satisfactory than the more elaborate courses of the high priced correspondence schools because it is simple and within the grasp of an ordinary man. Being simple, the mastery of the course will be persisted in by many students and the practical things they learn will increase the value of their services.

Any kind of business which pays more than ten per cent. annually is robbing some interests. It is generally their help, and every case of the kind leaves a prophet crying in the wilderness. "Let us become a nation of Socialists."



# Air Brake Department.

CONDUCTED BY J. P. KELLY.

## New W. A. B. Equipment.

In this number we begin the series of articles which will illustrate and describe the Westinghouse new air brake equipment, for all classes of engines and cars which are now in actual operation in all kinds of train service. We shall begin with the engine and tender apparatus, since this is the part of the equipment with which the majority of our readers, no doubt, will come first in contact.

The principal parts of this apparatus, already becoming familiarly known as

the return pipe conducts the air to the engineer's automatic brake valve and to the engineer's independent brake valve, the return pipe being divided into three branches so as to provide two connections for the automatic brake valve and one for the independent brake valve.

One branch of the automatic brake valve return pipe provides a direct passage for main reservoir air to flow through to the engineer's automatic brake valve, and the port in the brake valve to which this branch connects is so controlled by the rotary as to con-

nect to the air gauge red hand, which indicates at all times the main reservoir pressure.

The independent brake valve branch of the return pipe also has a feed valve placed in it, which regulates the pressure to the proper amount required in independent, or straight air, brake applications.

Between this feed valve and the independent brake valve the train air signal pipe connection is made. In the train air signal pipe there is a combined strainer and check valve, the

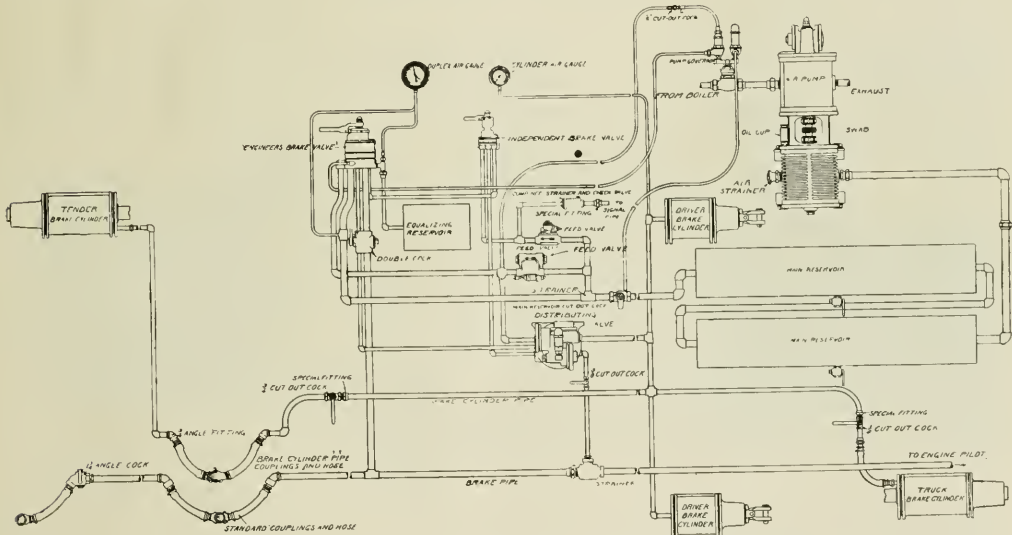

FIG. 1. DIAGRAM OF COMBINED AUTOMATIC AND STRAIGHT AIR BRAKE EQUIPMENT FOR LOCOMOTIVE AND TENDER.

the ET equipment, are shown in the half-tone engravings. They are the engineer's automatic brake valve, the automatic K feed valve, and the distributing valve. The parts of the present standard equipment which are displaced by the distributing valve are shown on the following page.

The piping diagram, Fig. 1, illustrates clearly the manner in which the various parts of this improved equipment are arranged upon the locomotive and the tender.

Commencing with the air pump, it will be observed that the compressed air is conducted to the main reservoir in the usual manner through the discharge pipe. From the main reservoir

connect it directly with the brake pipe only in train brake release position. From this it will be seen that main reservoir air can flow direct to the brake pipe when the automatic brake valve handle is in train brake release position only. The other branch has the automatic K feed valve placed in it, and it is connected to a port in the automatic brake valve so controlled by the rotary that it supplies air to the brake pipe only when the handle is in running position. In this manner the required proper brake pipe pressure is provided for, both in train brake release and in running positions.

Out of the direct main reservoir brake valve connection a smaller pipe leads

strainer to keep dirt out of the signal pipe, and the check valve to prevent backward flow of air to the independent brake valve. By this arrangement it will be observed that one feed valve is made to do duty both for the independent brake valve and for the train air signal, since both use practically the same pressure.

The automatic brake valve has the usual brake pipe equalizing reservoir and brake pipe air gauge connections, and in addition a pipe connection to the independent brake valve.

This latter connection, plainly shown on the diagram, is for the purpose of providing means whereby, in cases of double heading, the second engineer can

release his brakes independently of the leading engineer and without affecting any of the other brakes in the train, something that it is desirable to do when there is danger of overheating tires and in cases of wheel sliding. He can also apply the engine and tender brakes without applying the others on the train, independently of the head engineer.

To the distributing valve there are five distinct pipe connections: one from the engineer's automatic brake valve; one from the engineer's independent brake valve; one from the brake cylinder supply pipe branch of the return pipe; one from the driver, engine truck, and tender brake cylinders; and one from the brake pipe proper.

By means of these pipe connections

This governor has one pressure top, which is the same as now used with the present standard, piped to the main reservoir direct, the connection being made to the return pipe at a point between the main reservoir and the main reservoir cut-out cock; and it controls the pump, when the brake valve is lapped, or it is necessary, for any reason, to close the main reservoir cut-out cock. The other, known as the excess pressure top, has two pipe connections, one to the brake pipe feed valve branch of the return pipe, made at any convenient point between the feed valve and the brake valve; and the other connection to the automatic brake valve, direct, and is supplied with air from the direct main reservoir port.

The construction of this pressure top

brake pipe, so that they cannot be crossed when coupling them up.

The brake valves are mounted on permanent bases, and to these bases all the brake valve pipe connections are made, so that whenever necessary to remove the brake valves for cleaning or repairs no pipe joints need be disturbed.

The K feed valve is so constructed that, by turning the handle on the adjusting screw to one extreme position, main reservoir and brake pipe pressures of 90 and 70 lbs., respectively, are had; turning to the other extreme position, main reservoir and brake pipe pressures of 130 and 110 lbs., respectively, are had. By this arrangement but one feed valve is necessary either for the low pressure or for the high speed brake, and in addition, when using the ordinary 70-lb.

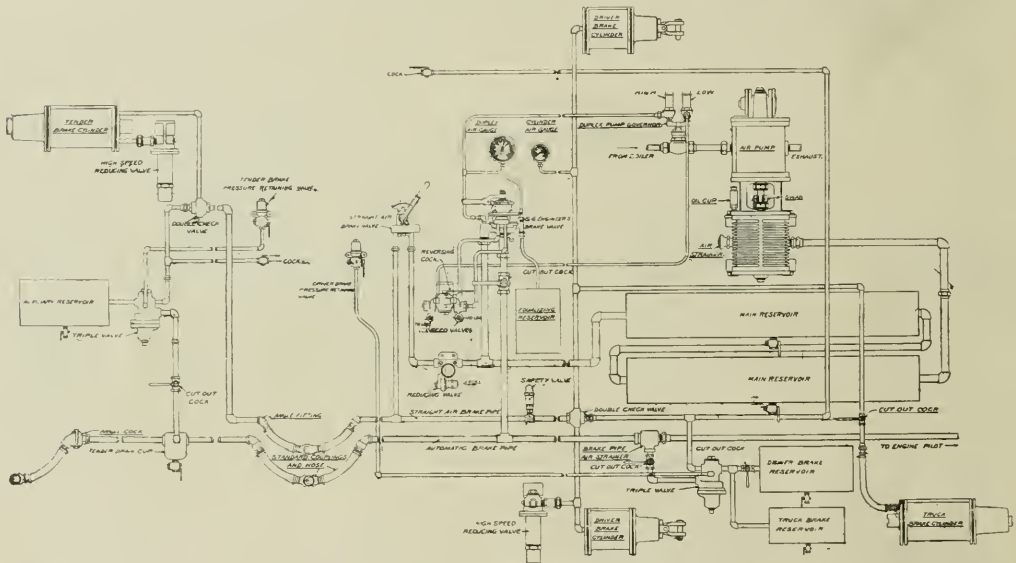

FIG. 2. DIAGRAM OF WESTINGHOUSE AIR BRAKE ARRANGEMENT, PARTS OF WHICH ARE NOW SUPERSEDED BY THE NEW "ET" EQUIPMENT.

the distributing valve is charged, the necessary variations in pressure made to operate the internal mechanism, and the supply of air conducted to the brake cylinders to apply the brake.

The internal construction of the various valves will be illustrated and described in a later number.

Beneath the automatic brake valve there is placed a double cut-out cock. This cut-out cock, when turned to closed position for the brake pipe, cuts out the automatic brake valve, but opens communication between the distributing valve and the independent brake valve by way of the pipe connection between them.

The duplex pump governor, shown in the diagram, is quite different from the older type of duplex governor.

is such that it provides for a differential pressure of twenty pounds between the brake pipe and the main reservoir pressures, regardless of what pressure the feed valve may be set at.

Between each of the brake cylinders and the distributing valve there is a cut-out cock, so that if any of these cylinders or their foundation brake gets out of order, they may be cut out independently of the others. In the brake pipe branch connection to the distributing valve there is a  $3\frac{1}{8}$ -in. cut-out cock for the purpose of cutting out simultaneously the engine and the tender brakes.

The brake cylinder hose couplings between the engine and the tender are of different dimensions from those of the

brake, high main reservoir pressure control is provided for.

From a glance at the picture of the parts of the old equipment displaced by the new, it will be seen that no auxiliary reservoirs and no triple valves are used with the latter. They are not necessary, since main reservoir air is used in all of the brake cylinders to apply the brakes, and the distributing valve being automatic in its action during the time the brake valve handle is on lap, keeps the brake cylinders supplied with air to the required pressure, regardless of leakage—something the triple valves do not do.

Length of piston travel or its variation makes no difference in the cylinder pressure developed, it being the same in all the brake cylinders on the engine

and the tender, regardless of these variations.

In order to enable our readers to compare the old engine and tender brake arrangement with the new, and to note more easily the differences between them, we publish the piping diagram, Fig. 2. This diagram shows the locomotive brake apparatus required to produce the same braking results as are obtained by the new locomotive and tender equipment, shown in diagram, Fig. 1. Names underlined on this drawing indicate apparatus which are identical in both equipments. The brake valves are of different design, and all the other parts on this drawing are replaced by the distributing valve and its attachments.

In mountain grade work the new equipment is much superior to the old, since there are no auxiliaries to recharge and no chance for brake cylinder air to leak away and reduce the holding power of the brakes. Also, the brakes on the engine and the train may be alternated at will by the engineer in holding trains down long grades, thus making it easier to recharge the train brakes without allowing the train

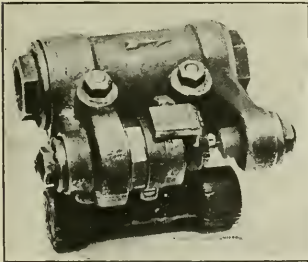

NEW "K" FEED VALVE.

to increase speed rapidly, and also lessen danger of overheating tires. On heavy grades, while the train is standing, the engine and tender brakes may be held applied while the train is being recharged.

The automatic brake valve used with the new equipment is improved in its construction, having much larger ports than the old; hence brakes on long trains are released much quicker and with greater certainty than with the older valve. The independent brake valve is of the rotary type.

This equipment embodies all the advantages of the combined automatic and straight air brake, and is adapted for use in all kinds of service, from switching to high speed, in each of which it has marked advantages over the older equipment.

For diagrams showing the different positions of the brake valve handles, and instructions for use of each, see

December (1905) number RAILWAY AND LOCOMOTIVE ENGINEERING.

#### Cool Place for Whistle Signal Valves.

Recently a couple of pieces of a diaphragm taken from a whistle signal

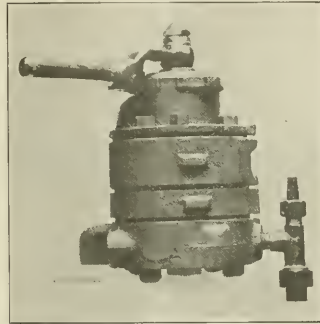

WESTINGHOUSE NEW EQUALIZING DISCHARGE AUTOMATIC BRAKE VALVE.

valve, whose location outside the cab had been changed to one inside close to the boiler, were sent to us for inspection.

The effect of the heat on the diaphragm was quite evident from the appearance of the pieces submitted for examination. They were brittle, easily broken when pressed between the fingers, and almost entirely without flexibility.

Heat is not a good preservative of rubber, and the whistle signal valve will always work more satisfactorily if located outside the cab than it will if placed inside.

## Air Brake Questions and Answers

DRIVER BRAKE CUT-OUT.

(22) C. E. S., of Lindale, Ohio, writes:

1. The new engines which we have recently received from the Brooks Locomotive Works are equipped with the new distributing valve, which takes care of all the brake cylinders on the engine and tender. Now, I should like to know what to do to cut out the driver brake in case it was necessary to do so? A.—Close the  $\frac{3}{8}$  in. cut-out cock in the branch pipe leading from the brake pipe to the distributing valve and place the handle of the independent brake valve in release position. See piping diagram, published elsewhere in this number of the new engine and tender equipment.

2. In cases of double heading with engines that have the new style brake, how do you cut out the brake valves on the second engine? A.—Close the double stop cock just below the brake valve just as with the older equipment, and in

addition place the automatic brake valve handle on lap position, and carry the handle of the independent brake valve in running position.

CURIOUS BEHAVIOR OF GAUGE.

(23) S. Z. T., of Pittsburg, Kan., writes:

I have an air brake question which I would like to have you answer in the columns of your valuable paper. This is a case where a regular man on a regular engine came in with brakes and gauge O. K., and nothing reported on air equipment. On going out he noticed the gauge, on making an application with handle in service position, the black hand would fall to the peg, either coupled to the train or with the light engine, and then fly back to the 70 lb. mark, but as soon as the pressure equalized between Chamber *D* and the train pipe, the hand would be still. There was no trouble with brakes leaking off, and on the next trip out the gauge was O. K., although the engineer did not report it. What was the matter? A.—In all probability there was a restriction in the equalizing reservoir pipe connection at the brake valve which did not permit the air to flow from the equalizing reservoir back into chamber *D* as fast as the air could escape from this chamber through the small prelim-

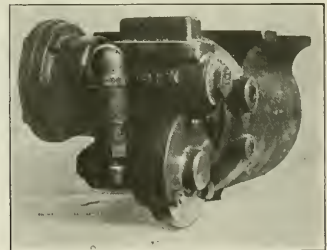

DISTRIBUTING VALVE.

inary exhaust port. This would allow the black hand to drop to the zero mark or near it. The pressure thus suddenly reduced in chamber *D*, on one side of the restriction, which was probably a gasket improperly applied in the brake valve union, would permit the pressure in the small reservoir to enlarge the restricted opening and allow the air to flow more freely into chamber *D*, and hence suddenly increase the pressure therein, causing the black hand to move back close to the 70 lb. mark on the gauge, and this operation could repeat itself several times during the time the handle remained in service position, causing the black gauge hand to move up and down as noticed.

However, there must have been, with this action an intermittent exhaust of brake pipe air at the brake valve service exhaust elbow fitting, of which your letter makes no mention.

After the gauge black hand had worked in the manner you describe for a portion of the trip, the restriction naturally became enlarged, or was removed altogether, when the air gauge black hand resumed its normal action.

#### ADJUSTMENT OF DUPLEX GOVERNOR.

(24) J. R. B. writes:

1. How do you adjust a duplex governor, with brake applied or valve in full release? A.—Assuming that you mean the duplex pump governor as used with "high main reservoir pressure control," when adjusting the low pressure top the handle should be in running position, and when adjusting the high pressure top the handle should be placed on lap.

2. Explain how the duplex pump governor is attached to the brake valve and what ports does it connect? A.—The pipe connection to the high pressure top is made direct to the main reservoir passage in the brake valve, just above the main reservoir return pipe connection; and the low pressure governor connection is tapped into the brake

of the passage therein, such as an angle cock almost closed to such extent that air could pass but slowly through it, you could charge the whole train to the standard pressure; but when making a service application you could not reduce the brake pipe pressure in the section of pipe back of the restriction at the same rate that you could in the section in front of it. Hence, after making a service reduction, and lapping the brake valve, the air could feed into the forward portion of the brake pipe, increase the pressure therein and release the brakes. On account of the very slow feeding in of the air from the section back of the reduced passage the brakes on that portion would commence to apply when the others ahead were releasing, which probably gave you the impression that all brakes had released.

#### Parting of Hose by Hand.

Editor:

I notice under the head of "Air Brake Department," in the RAILWAY AND

to become careless in the matter. For the first offense, or violation of this rule, an actual suspension of ten days is recorded against the trainman; second offense, twenty days; third offense, thirty days; and fourth offense, a dismissal.

Discipline when administered properly brings about the desired result, and the word "carelessness" will be driven out by a higher efficiency in this direction.

I am inclined to believe that to hire men for the special purpose of separating air hose on all trains coming into the yards is quite an additional cost or expense to the air brake department, and could be easily avoided by following the practice of the N., C. & St. L. Ry.

OTTO BEST,  
A. B. Inspector.

Nashville, Tenn.

[Taking a second look at the paragraph referred to by our correspondent, we think it should be modified to the extent of making a few exceptions, such as in the case of the road on which Mr. Best has charge of the air brakes; but in the main we think our statement will carry without danger of misrepresenting conditions as they actually exist with regard to hose parting on the majority of railroads.

It is certainly to the credit of any road to follow the practice of parting hose by hand, as is done on the Nashville, Chattanooga & St. Louis, when separating cars; but all roads may not be able to get it done in the same way. Hence they should adopt the method best suited to them to accomplish the desired result, even though the method chosen may be a little more expensive to them than to some others, since the object to be accomplished is such an important one.—Ed.]

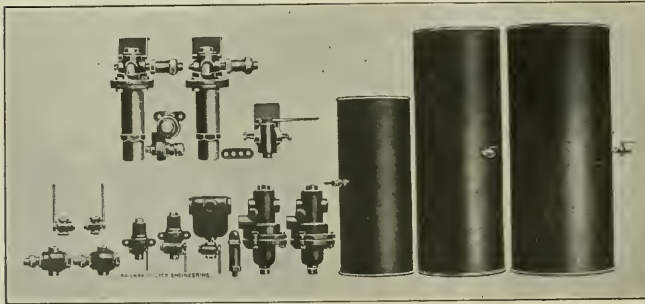

PARTS OF STANDARD EQUIPMENT DISPLACED BY THE DISTRIBUTING VALVE.

pipe feed port passage between the seat of the rotary and the feed valve connection on the side of the brake valve.

3. What will cause brakes to release on a train of twenty-nine cars, all brakes cut in, in making a service application, with brakes fully applied, lapped brake valve, all brakes released, engine tank and all. We could not find the cause, as engine equipment was in first class shape and engine brakes would not release when the engine was cut off from train and handle on lap. A.—Since the brakes operated properly on the engine and tender when the engine was cut off from the train, it is evident that there was no leak of main reservoir air into the brake pipe, that could increase the pressure in the latter sufficiently to release any brakes, hence the increase of pressure in the brake pipe necessary to release the brakes on the train and engine must have come from the rear of the train. If somewhere near the twentieth car there was a restriction in the brake pipe that reduced the size

LOCOMOTIVE ENGINEERING for month of January, 1906, an article headed "Parting Hose by Hand."

I beg to differ with the writer in his statement in first paragraph. The parting of air hose by hand has been satisfactorily solved and carried on to a degree of perfection on the road that I represent, the Nashville, Chattanooga & St. Louis Railway.

About ten years ago bulletin notice was issued, stating that when freight trains arrive at terminal points the trainmen would be required to uncouple all air hose before leaving train; the head brakeman starting from head car and uncoupling back, and the rear brakeman from the caboose, uncoupling ahead.

I will agree with the writer that yard switchmen do not think they can take the time, and we find that they cannot, in busy yards; but we do know that when a freight train arrives at a terminal point the trainmen can do this work. We do not allow the roadmen

One of the most common complaints that come to this office is from persons who have secured letters patent from the United States Patent Office and afterwards find out that the papers do not entitle them to the protection of the Government against infringement. Patentees ought to understand that the granting of a patent merely gives publicity by the United States that a new and useful device has been invented, and it is for the courts to give protection to the patentee when application is made through the usual channels.

At a recent meeting of the Western Railway Club, Mr. A. R. Raymer, of the engineering department of the Pittsburgh & Lake Erie, described a boiler cleaning plant in use at one of their roundhouses by which the foul water is removed from locomotive boilers, the heat is saved and used in heating the water for refilling the boiler.

**Monon Passenger 4-6-2.**

The Chicago, Indianapolis & Louisville Railway Company is generally spoken of as the Monon Route or more shortly as the Monon. This word, as applied to the C. I. & L., is taken from a small river named the Monon, which flows near the town of Monon, Ind., and it is said to be derived from an Indian word meaning "swift running." In this latter respect the new Pacific type passenger engines recently built at the Brooks shops of the American Locomotive Company will probably keep up the original meaning of the road's short name.

The engines are simple, with cylinders 21x26 ins., and they have 69-in. driving wheels. The boiler pressure is 200 lbs., and the calculated tractive effort, as given by the builders, is 28,250 lbs. The total weight is given as 203,500 lbs., of which 123,000 rests on the drivers. All the wheels are flanged and the springs are all overhung and connected by equalizers made of cast steel, which are placed between the upper and lower frame bars. The main valves are

have a hook-like section and grasp the raised, rounded ends of the driving springs. The journals of the carrying wheels under the cab are outside and measure 8x14 ins. The wheels are 50

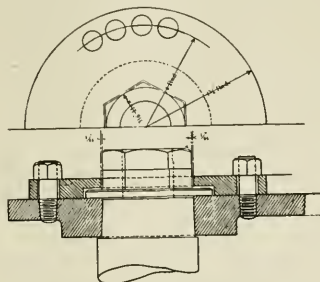

WRIST PIN NUT LOCK.

ins. diameter, the truck is radial and the top of the boxes are provided with roller bearings to allow for the necessary side movement.

The butt end of the main rod is forked and resembles some forms of

in the disk is made hexagon and fits over the nut with just a 1-64 in. clearance on each face. The disk is held in place by two 3/4 in. studs and there are four stud bolts top and bottom, any two of which may be used in securing the proper adjustment of the disk. When everything is in place the wrist pin nut is there to stay and cannot even begin to slack off because the disk, when being tightened up, can be made to touch the corners of the nut. The device is simple and effective and can be easily removed when repairs are necessary.

The boiler is not exactly a straight top one, as the middle course or the one on which the sand box is placed tapers from front to rear. The first course measures outside 64 1/8 ins. and the dome course outside is 69 3/4 ins. The middle course is tapered so as to unite these two. The tubes are 290 in number, 18 ft. 6 1/2 ins. long, and give a heating surface of 2,707 sq. ft. With the 162 sq. ft. of the fire box, the total heating surface comes up to 2,959 sq. ft. The grate area is 44.8 sq. ft. The stay-

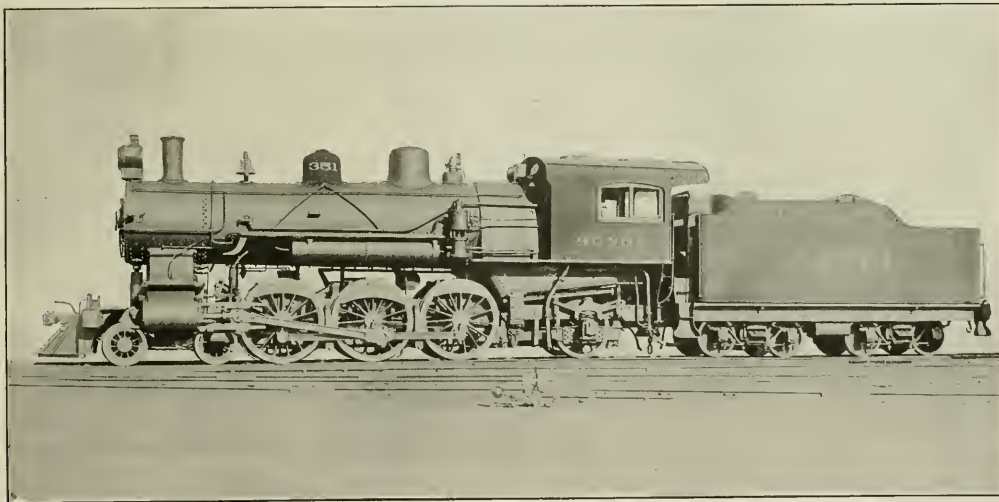

John Gill, Superintendent of Motive Power.

PACIFIC TYPE ENGINE FOR THE MONON.

American Locomotive Co., Builders.

the 11-in. improved piston type and are driven by direct motion. The valve travel is 5 5/8 ins., with steam lap 1 1/8 ins. and no exhaust lap. The valves are set with what the builders call negative lead amounting to 1/8 of an inch in full gear. The expression negative lead may not be altogether clear, because instead of these engines having any valve opening at the beginning of the stroke, which is lead pure and simple, the valve really overlaps the port 1/8 in. when the piston is about to begin its stroke. The reach rod is made of 2-in. extra heavy iron pipe, and the spring hanger joints

marine design. The brasses are held in place by a heavy bolt and spacing piece. The wrist pin is fitted with a patent nut lock designed by Mr. D. R. McBain, who is division master mechanic of the Michigan Central at Jackson, Mich. The nut lock, details of which are shown in our line engraving, consists of a wrist pin nut having a wide flat circular collar 3/8 in. thick. When the nut is screwed home the flat collar lies against the crosshead, and over this collar a flat disk 9 1/2 ins. in diameter and 3/4 in. thick is placed. The disk is recessed out so as to enclose the collar and the opening

ing of the crown sheet radial and crown and fire box side sheets are all one piece. The back sheet slopes toward the front a distance of 20 ins., but crown and roof sheets are level with a 2 1/2-in. water and steam space above the crown. The back sheet is strongly stayed by a series of deep gussets which unite the portion above the crown sheet level, with the roof sheet.

The tender is carried on a pair of ordinary arch bar trucks, and the frame is made of 13-in. steel channels. The tank has a water bottom and carries 7,000 U. S. gallons of water and 15 tons

of coal. The weight of engine and tender is 352,300 lbs., and the total wheel base of both together is 59 ft. 6½ ins. The machine is well proportioned and has the appearance of strength and elegance. A few of the principal dimensions are as follows:

Wheel Base.—Driving, 12 ft. 4 ins.; total, 31 ft. 8 ins. Axles, driving journals, 9 x 12 ins.; engine truck journals, diam., 5½ ins.; length, 12 ins.; tender truck journals, diam., 5½ ins.; length, 10 ins. Boiler, fuel, soft coal. Fire box, length 96 ins.; width, 67¼ ins.; thickness of crown, ¾ in.; tube, ¾ in.; sides, ¾ in.; back, ¾ in.; water space, front, 4½ ins.; sides, 4½ ins.; back, 3½ ins.; Crown staying, radial, with 1¼-in. staybolts. Boxes, diam. of driving journals, 9 x 12 ins. W. A. B. pump, 11 ins.; 2 reservoirs, 18½ x 120 ins. Engine truck, swivelling and swing, 3 point suspension. Piston rod, diam., 3¾ ins. Driving wheels, material, cast steel.

### Knowing Things.

The advantage of knowing things was amusingly illustrated by Mr. J. M. Daly, of the Illinois Central, at a meeting of the New York Railroad Club. He said: "Some years back, many division officers were prone to memorize the tonnage each engine could haul, but conditions have outgrown this. That reminds me very much of the Napoleon story: The story runs that on one of his annual tours of inspection through his provinces, he, as was his custom, questioned the different governors on conditions, etc. He generally traveled in state, and endeavored to impress all with the dignity of his position, etc. The first governor he asked, 'What is the altitude of your quarters?' The governor, who was honest, admitted that he did not know exactly, but would ascertain in a minute, but the Emperor replied, 'No, never mind.' The next question was, 'What is the distance to so and so?' The governor informed him he was not sure, but asked leave to go in the next room and consult his charts. Napoleon only replied, 'No, never mind.' The third question was, 'What is the population of your province?' He replied in the same way that he did not know, but would find out. Again Napoleon said, 'Never mind.' After a few other questions the interview closed. Napoleon then turned to his lieutenant and told him to get somebody there who knew something. A few days later the same situation was brought out at the next conference, but the third governor answered his questions. The altitude, he said, where Napoleon stood, was 4,387 ft. 5 ins.; the distance to the point in question was 110 leagues, 38 furlongs, 6 ft. 8 ins., and to Napoleon's next question, 'What is the population of your province?' he replied, '112,588—excuse me, make it 112,589, as there was a child born this morning.' To all of these replies Na-

oleon gave him a very knowing look, and after the interview was closed, his lieutenant made inquiry as to whom he should install in this governor's position, to which Napoleon replied, 'You will arrange to make this man governor of the entire provinces. He is an awful liar, but he is mighty smart.' (Laughter.)

"This, to an extent, was the condition years ago on railroads, when division officers thought it necessary to memorize and keep posted on the detailed capacity of each engine, and the number of loaded and empty cars handled each day; but things have changed, and at the present time the executive officers want facts, and when they ask for detailed information of this kind they expect the superintendent or division officer to produce his data or statements showing such facts, and when the manager going over the road sees freight trains moving at a lively rate of speed, he thinks they are under-loaded. These statements, showing the trains hauling their maximum tonnage leaving the ends of districts and filling-out points, come in very handy for the superintendent in convincing the manager that his trains are fully loaded leaving the points where it is possible to give them full tonnage—that, no doubt, the trains which he noticed going at a high speed were moving on favorable portions of the divisions where the grades are light."

### How They Say It in Spanish.

"One good turn deserves another," is well expressed by "One should pay love with love."

"Look before you leap," is brought home to the young man and woman by "Before you marry look at what you are going to do."

"A hog is always a hog" is well matched by "A monkey dressed in silk is still a monkey."

"He drinks like a fish" is even better expressed by "He drinks like a drunkard." The Spanish word for drunkard is cuba, which also means cask. So the proverb may be rendered, "He drinks like a cask."

"A wise head keeps a close watch," is very fittingly matched by "Flies do not enter a closed mouth."

Instead of "When you are in Rome do as the Romans do," they say, "Wherever you go, do as you see."

We say, "Hunger is the best sauce." The Spaniard says, "Hunger does not find the bread hard."

"Out of sight out of mind," is rendered by "There are no friends to those dead and gone." Either way is always true.

"A foolish question requires no answer" is boiled down into "Foolish words, deaf ears."

"A word to the wise is sufficient." is

cut in half by "Half a word is enough to him who understands."

"A bird in the hand is worth two of the bush," is multiplied by the Spaniard, who says, "A bird in the hand is more valuable than a hundred flying."

Those who call upon their saints for help are told to remember that, "If God is not willing, the saints are unable."—*Graphite.*

### The Ancient Bellows.

People of America have little familiarity with the domestic bellows which in Europe is a necessary utensil of every household, where in cold weather it is used to blow the open fires.

The bellows is as old as civilization, and is doubtless associated with the invention of the pump, for bellows have been employed as pumps for throwing water, and pumps employed as bellows for blowing air. The bellows is also closely connected with the development of valves, for the bellows was probably the first implement in which a valve was used.

There are references to the bellows in the oldest writings that are preserved. The oldest and most unchanged civilization on the globe is found in Hindustan, and the blacksmiths of that country still use bellows similar to those found figured in the forges of Vulcan on ancient medals and sculpture. This was the lantern form of bellows, which has remained as unchangeable as the blacksmiths themselves.

Isaiah, who lived in the eighth century B. C., alludes to the smith that bloweth the coals in the fire, and Homer wrote:

"Obscure in smoke, the forges flaming  
round,  
While bathed in sweat from fire to fire  
he flew,  
And puffing loud, the roaring bellows  
blew."

### Ether.

Science is supposed to be the exposition of some line of truth, but the exponents of science sometimes fall into curious vagaries. For instance, we are told that ether is a medium that pervades all space, and is regarded as possessing extreme tenuity and elasticity and as being a medium of transmission of light and heat, these forces being transmitted by vibrations or undulations of this ether. It seems to us that this is pure scientific speculation, and it sometimes leads to absurdities. A learned professor dilating on ether in the course of a lecture, said: "All mass is mass of the ether, all momentum, momentum of ether, and all kinetic energy, kinetic energy of the ether." Perhaps that explanation is intelligible to some persons, but to us it is a mere collection of words.

### Tough Ties and Living Fence Posts.

Our old friend, Mr. B. L. Wooster, master mechanic of the Cartagena-Magdalena railroad, paid us a flying visit a few days ago. The road he is connected with is in the republic of Colombia, in South America. Mr. Wooster is here on business connected with his company, and is making inquiries relative to purchasing some new locomotives and some material for use by his department.

An interesting feature connected with this railroad is the fact that lignum-vitæ ties are used in the roadbed. The gauge of the road is 3 ft., and though the ties are smaller than those used on our standard gauge roads, they cost about as much as ours do.

The wood is exceedingly hard, and lasts about ten years in that country. It is comparatively easy for the Cartagena-Magdalena road to get these ties, as the tree grows along the line. The great hardness and toughness of lignum-vitæ wood is due to a very peculiar interlacing of the fibers. The heart is dense and heavy, and usually of a dark greenish-brown color.

The wood is too hard to drive track spikes into it in the usual way, so when ties are piled along the side of the road a gang of men supplied with suitable templates bore  $\frac{3}{8}$ -in. holes in the wood to a depth of almost 3 ins., and these holes are filled by the spikes which fit them so that the corners of each spike embed themselves firmly in the wood, and when the spike is right "home" it has been driven about 1 in. into the unbored portion of the tie at the bottom of the hole.

The fences along this road are made of wire, which is supported on posts of the wood called down there the Mata Raton, which, being freely translated, means rat killer. The bushy tree used for these fence posts gets its local name from the fact that its leaves, when put at or about a rat hole in a house, either kills the rat or causes him such acute discomfort that he desires to breathe an "ampler ether, a diviner air," somewhere else, and leaves for parts unknown. The tree has much vitality, and when sawed off and trimmed into the form of fence posts and "planted" by the section men, keeps on growing as if nothing had happened, and often the curious spectacle may be seen of flourishing bushy trees supporting wire fencing, growing beside the line of railway. It is probable that in such cases rats do not trespass much on the right of way.

There are a number of wooden trestles and bridges on this railroad, built for the most part of southern pine, creosoted in order to preserve the timbers. This treatment of the wood is efficacious in keeping it from rotting,

but it does not hinder the *comajen* ant from getting in his work. So serious are the ravages of this insect that timber attacked by it is soon honeycombed and eaten through, and the company is replacing the trestles with fills pierced by stone culverts, and the bridges with steel structures. It seems as if the insect thrives on creosote, and the busy ant by its action seems to say, "If you want to preserve your bridge timber on South American railroads, you had better use some nauseous drug to prolong its life, and not the toothsome and delicious creosote with which we eat, drink and make merry."

### Different Kinds of Foremen.

Successful manufacturing concerns are noted for the care exercised in the selection of shop foremen, but in many railroad works the principal considera-

\$1,300 a month in labor alone, and was producing more and better work than his predecessor."

### Only the President Pays.

The United States make liberal allowance for the traveling expenses of every Senator, Representative and Territorial Delegate in Congress. The Government pays for their junkets, their funeral cars, their committee tours. It is so generous that several eminent statesmen hoped confidently to be transported to the Philippines and entertained there free of cost when the first invitations for the Taft expedition of last summer were issued. And yet the President is expected to foot the bills when he is called from one side of the continent to the other on the nation's business!

Every commissioner, clerk, special agent, every inspector of red tape, every

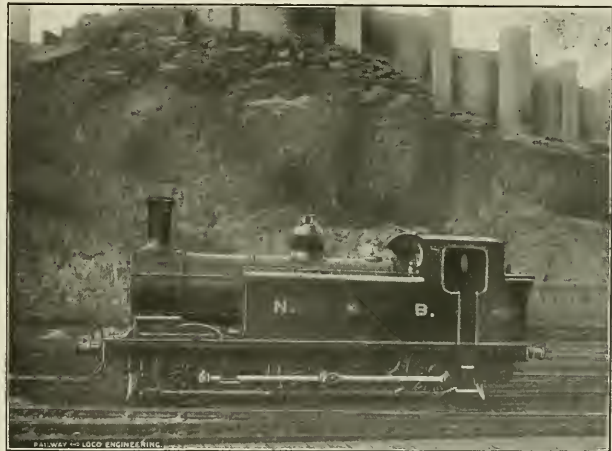

NORTH BRITISH 6-WHEEL COUPLED LOCOMOTIVE, NEAR WAVERLY STATION, UNDER THE WALLS OF EDINBURGH CASTLE.

tion is cheapness. We are not acquainted with any case where cheapness for a foundation is so expensive in results. We heartily endorse the following remarks made by Mr. M. K. Barnum at a railroad club meeting:

"The difference between good and poor foremen is often underrated, and it is not uncommon for a railroad company to allow a good foreman to leave rather than pay a few dollars more a month or to retain a poor foreman because they think he is cheap. The wastefulness of poor foremen is not generally realized. We knew one case where a foreman was not satisfactory, and the management was advised that \$500 a month could be saved by putting in an efficient and up to date man. This finally was done and within 90 days after the change the new man had saved

officer of the army and navy, every stenographer and watchman, every soldier and sailor who moves about on Government concerns charges his railway fares, sleeping car tickets, hotel bills to a Government account. Even the gratuities that Government employes dispense for personal service when they are away from home are charged up against the Government. But when the President answers the demands of his employers and responds to their invitations to visit and meet them, he is told that he must dip into his private bank account and defray for himself the charges he incurs.

No servant of the people does work more difficult or performs duties more important than does the President when he leaves the capital to visit the voters in their homes. Frequent trips of the

Chief Magistrate to the remotest sections of the nation have become as necessary as many other tasks that are laid on him by custom and habit. He should not be called on to pay for them out of his own pocket. He should travel in a Federal train, the best that the car builders' art can build, at Federal expense. The Fifty-ninth Congress should provide for a President's train and traveling expenses.—N. Y. Sun.

#### Pullman Palace Car Company.

The Pullman Car Company pays 8 per cent. on its capital stock, but it earns 13 per cent., and the balance of 5 per cent. goes into the mysterious blind pool called a sinking fund. This accumulation of earnings will be divided some day unless the people insist on passing laws which will reduce the earnings of the company. That such a movement should be made is by no means unlikely. The Pullman Palace Car Company is operated on the rigidly righteous principle that gives nothing more than the law exacts. There is no love lost between it and the people who depend upon it for employment; but its managers soothe with great skill legislative winds so that they never become tempests. In these days of independent action it would not be surprising if public opinion forced legislators to refuse lobbyist soothing syrup when questions of Pullman rates were to be voted upon.

#### Demand for Curtis Turbines.

The General Electric Company has just received an order from the Chicago Edison Company for two 8,000 kilowatt Curtis steam turbines and generators. These machines are each capable of developing 18,000 h.p. This order is a duplication of one formerly received from the Chicago Edison Company for two similar machines, making a total of four machines for the company.

The New York Edison Company has also recently ordered two machines of this size. These are the largest steam turbines ever designed, the six units referred to being capable of producing a total of 108,000 h.p.

The Chicago Edison Company just started up its fourth Curtis turbine unit of 5,000 kilowatt capacity. This company was the first to install and operate a Curtis turbine of this size.

#### Historical Gauges.

People who are fond of looking "forward into the past," as an excited political orator once phrased it, are the kind of people who get a good idea of what progress has been made in any given art or science. For instance, one of the delvers into old things tells us that the first pressure gauge ever made

was a simple U-shaped tube, partly filled with mercury so that pressure admitted to one side depressed the mercury on that side and raised it in the other. This form of gauge is sometimes used with water to get the ounces of air pressure in a blast furnace in a foundry. The French government as late as 1843 required the use of an open tube gauge like this for engines using pressure under 60 lbs. and for steamboats using under 30 lbs. A sealed tube was used for higher pressures.

Following this form were many, but the two that survived were the "Bourdon tube" and the "diaphragm." The Bourdon tube is practically the flattened pipe which we see in many steam gauges to-day, only nowadays it is held tightly in the middle with the two ends free to move, whereas the original type was held rigidly at one end, leaving the other free to move. The diaphragm gauge appeared in 1849 and was made so that a yielding partition or diaphragm divided, through the center, a chamber below the gauge. Pressure acting on this diaphragm

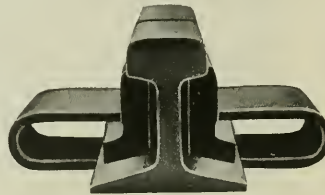

SPRING CLAMP RAIL SPLICE.

moved its center up or let it come down, as the case might be, and the motion of the diaphragm was communicated through a vertical spindle fastened to a rack into which a pinion carrying the pointer was geared.

A later form of the diaphragm principle is that used by the Utica Steam Gauge Company, of New York, and their modification consists of a circular box, the lid and base of which are made of corrugated metal and the edges flanged and locked together above and below the level of the corrugations by an elastic metal band. This spring box is practically a capsule, of which the top and bottom corrugated plates both move. The company have compiled a little hooklet on "historical pressure gauges," from which the facts here presented have been drawn. They will be happy to send a copy to anyone who signifies his interest in the subject by writing them; their illustrated catalogue may also be had for the asking, and there is a neat little vest pocket folder of 8 pages concerning Tips on Repairs which ought to be in the hands of all gauge repair men who are on the lookout for information about the Utica steam gauge.

#### Spring Clamp Rail Joint.

Our illustration shows what is known as the Palmer rail joint. It consists simply of two splice bars or angle plates and two spring clamps. No bolts are required, and, consequently, no bolt holes are needed in the rails or in the angle plates. There is, however, a groove at the center of the splice bars, and into these grooves the ends of the spring clamps fit. The clamps are made of 4x4½ in. high carbon spring steel and tempered.

When the clamps are in position they are opened to the extent of about ¼ of an inch, and when tested by the engineering firm of Robert W. Hunt & Co., of Chicago, this was found to be equal to a pressure of from 12,000 to 15,000 lbs. The spring clamps, in addition to firmly uniting the rails, brace the joint laterally and so help it to withstand the side thrust of the flanges of the wheels. The pressure of the clamps is all that is required to take up any wear between the splice bar and the rail, but in this case any such wear is very slight owing to the rigidity of the whole joint.

The joint has passed beyond the experimental stage, as it has been subjected to a severe service test for over a year in the terminal yard of one of the roads running into Chicago. At this point a heavy switch engine constantly passed and repassed over the rail joint both day and night. The Palmer joint gave every satisfaction, and when recently examined was found to be in first-class condition, while the old fashioned joint on the opposite rail was found to have loose bolts, worn rails and a considerable movement at the passing of every wheel.

At or about the beginning of the year 1906 a good many calendars came to our office, and among those we have received we must make mention of that from H. B. Underwood & Co., of Philadelphia. This calendar is a good one for office or shop use, as it is about 14x 22 ins. in size, and is printed in two colors. The figures are in plain, clear, black type, and the names of the days of the week and the figures representing Sundays are printed on a red background. The rest of the figures are black on a white ground, each enclosed in a square of about 1¼ ins. a side. This company are the makers of special tools for railway repair shops, and their product includes portable facing arms, radius planer attachments, portable cylinder boring bars, portable milling machines, crank pin turning machines, rotary planing machines, etc. Write to the Underwood Company if you want a good and easily read calendar.



# Of Personal Interest.

Mr. B. E. Taylor, formerly assistant to the president of the Chicago, Indianapolis & Louisville Railroad, has been appointed general manager and purchasing agent of the same road, with headquarters in Chicago. The duties of general manager have hitherto been performed by Mr. W. H. McDoel, president of the company, but with the beginning of the year the change outlined above was made. Mr. Taylor was born at Plymouth, Mich., on May 25, 1863, and entered railway service at that point on September 3, 1879, as a station helper, on the Flint & Pere Marquette. From that date to March, 1885, he was consecutively telegraph operator and relief agent, operator, abstract clerk and

When the Chicago, Indianapolis & Louisville was organized, after the older company had been wound up, on July 1, 1897, he became chief clerk to the vice-president and general manager, in addition to having filled the office of purchasing agent since July 1, 1895. Later he was given the position of chief clerk to president and general manager, and also retained that of purchasing agent, and from March, 1903, to January 1, 1906, he was assistant to the president in addition to being purchasing agent of the road, and on January 1, 1906, he was promoted to the responsible office of general manager and purchasing agent of the Monon.

Mr. W. W. Lowell, master mechanic of the Chicago, Burlington & Quincy, at Brookfield, Mo., has been transferred to St. Joseph, Mo.

Mr. H. P. Durham has been appointed superintendent of motive power and machinery of the Tehuantepec National, with headquarters at Rincon Antonio, Mexico.

Mr. E. S. Brooks has been appointed purchasing agent of the Mobile, Jackson & Kansas City, with headquarters at Mobile, Ala.

Mr. C. Kyle, master mechanic of the Lake Superior division of the Canadian Pacific, has been transferred to the Eastern division of the same road, with headquarters at Montreal, Can., succeeding Mr. J. B. Elliott, recently appointed general master mechanic of lines east of Fort William.

Mr. J. W. Smith, formerly a freight engineer on the Montana division, has been appointed to the position of traveling engineer on the Great Northern, vice Mr. G. W. Herren, promoted.

Mr. H. C. Shields, formerly master mechanic of the Lehigh & New England Railroad at Pen Argyle, Pa., has been promoted to the position of superintendent of the same road, with headquarters as heretofore, vice Mr. Daniel Hardy, resigned. The transfer of Mr. Shields from the mechanical to the operating department of the road, with which he is connected, is one more in the growing list of such appointments, and RAILWAY AND LOCOMOTIVE ENGINEERING has pleasure in recording the fact and in congratulating Mr. Shields and the company he so ably serves. A well trained mechanical man always makes a desirable transportation official, inasmuch as such a man has much information pertaining to both departments

drawn from years of close contact not only with his own department but with operating problems, and his mechanical knowledge usually proves to be a valuable asset in the transportation department. Mr. Shields began his railroad work as an apprentice in the Kingsland shops of the Lackawanna in 1886. After serving his term he became chief engineer of the Seacaucus Iron Company. Leaving this on shore position, Mr. Shields was next appointed chief engineer on a U. S. government steamer, plying between Fort Hamilton and Sandy Hook. In 1891 he took service as fireman on the Erie Railroad and later as fireman on the D., L. & W., and on this road he was advanced to the



B. E. TAYLOR.

bill clerk at East Saginaw, also clerk in the office of the assistant general freight agent and cashier at Milwaukee. In 1885 he went to the Michigan Central as clerk in office of assistant general freight agent at Detroit. The following year he became chief clerk to general superintendent of the Florida Railway & Navigation Company, at Jacksonville, Fla. In the summer of 1887 he joined the service of the Louisville, New Albany & Chicago Railway in the capacity of chief clerk to the general superintendent. This road was the original name of the Monon Route and on it Mr. Taylor was later given the position of chief clerk to the general manager. In 1891 this road went into the hands of a receiver and during the six years occupied in liquidation, he was chief clerk in the office of the receiver.



H. C. SHIELDS.

right hand side in 1895. Leaving the footplate he was made roundhouse foreman of the Sussex division of the Lackawanna at Newton, N. J. While in that position he acted as assistant train master. His next move upward was that of assistant to the general foreman of the Central Railroad of New Jersey at Phillipsburg, N. J. Returning to his old road, the D., L. & W., he became division foreman of the B. & P. division at Bangor, Pa. Later he was appointed master mechanic of the Lehigh & New England at Pen Argyle, Pa., and with the opening of this year he became superintendent of the same road. Mr. Shields has earned his promotions and they have come to him as rewards for his ability and hard work. He carries with him the best wishes of a large circle of friends, who look forward to and

hope for his continued and deserved success.

Mr. G. T. Fulton, formerly general foreman of the Carleton Junction shops of the Canadian Pacific, has been appointed master mechanic of the Canadian Pacific, with headquarters at North Bay, Ont., Can.

Mr. W. P. Carroll has been appointed engine house foreman of the New York Central, with headquarters at East Buffalo, N. Y., vice Mr. E. C. Holtz, resigned.

Mr. F. A. Stevens, formerly master mechanic of the North Shore Railroad, has been appointed superintendent of

tral, and also of the Houston East & West Texas and the Houston & Shreveport, with headquarters at Houston, Tex.

Mr. W. N. Foreacre has been appointed assistant general superintendent of the western division of the Southern, with headquarters at Birmingham, Ala.

Mr. E. J. Harris has been appointed general foreman of the Rock Island machine and car shops, with headquarters at Valley Junction, Ia., vice Mr. D. E. Sullivan, resigned.

Mr. J. B. Pall has been appointed general superintendent of the Louisiana division of the Texas & Pacific, with headquarters at New Orleans, La.

Mr. A. G. Wilson has been appointed assistant superintendent of the Gonds-

Standard Paint Co. Mr. Michel is a graduate of Rose Polytechnic Institute. The Geo. H. Gibson Co. writes and conducts the advertising of a number of engineering concerns, but is not an advertising agency in the usual sense of the term, that is, it does not deal in advertising space or material, nor does it receive commissions from the papers,

Mr. F. M. Fryburg, formerly master mechanic of the Montana Division of the Northern, has been appointed general master mechanic of the Montana Central Railway and its branches.

Mr. Geo. W. Herren, formerly traveling engineer, has been appointed master mechanic of the Montana division of the Great Northern, vice Mr. F. M. Fryburg, resigned.

Mr. F. S. Anthony, recently connected with the Atlantic Coast Line Rail-

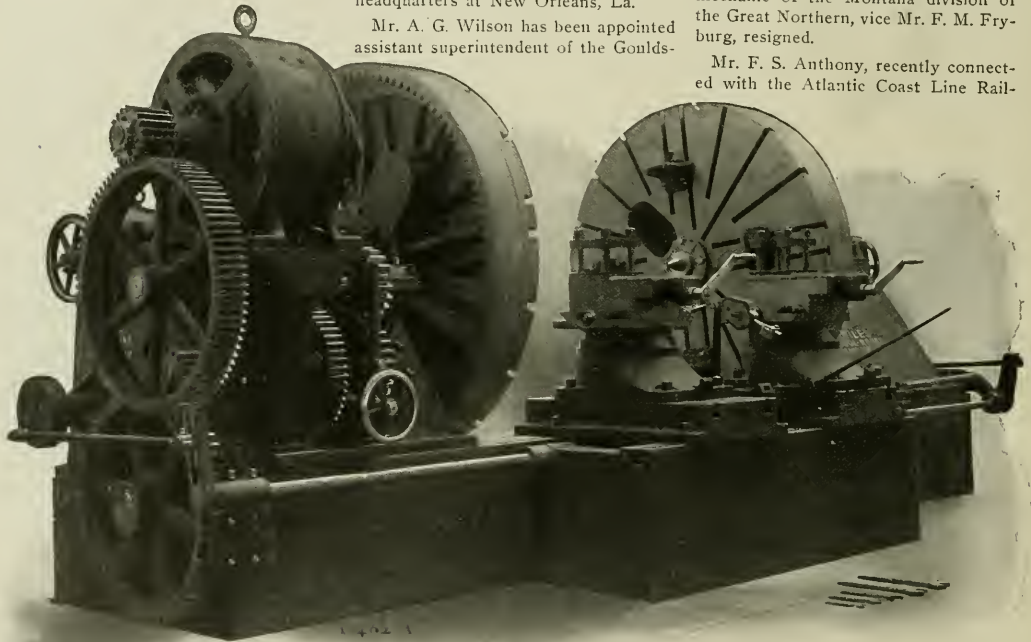

90 INCH DRIVING WHEEL LATHE, MADE BY THE NILES-BEMENT-POND CO., NEW YORK.

the Yosemite Valley, with headquarters at Merced, Calif.

Mr. Ellsworth Brown has been appointed assistant road foreman of engines of the Buffalo and Rochester divisions of the Pennsylvania, with headquarters at Buffalo, N. Y.

Mr. A. W. Byron has been appointed assistant master mechanic of the Buffalo and Allegheny Valley division of the Pennsylvania, with headquarters at Olean, N. Y.

Mr. S. Millican has been appointed superintendent of motive power and machinery of the Houston & Texas Cen-

boro division of the Texas & Pacific, with headquarters at New Orleans, La.

Mr. A. R. Andrews has been appointed assistant superintendent of the Marshall division of the Texas & Pacific, with headquarters at Marshall, Tex.

Mr. E. C. Holtz, formerly engine house foreman of the New York Central at East Buffalo, has resigned to take a position with the American Locomotive Co. at Dunkirk, N. Y.

Mr. A. Eugene Michel is now with the Geo. H. Gibson Co., advertising engineers, New York City, having resigned as assistant advertising manager of the

way, has been appointed master mechanic of the Lehigh & New England Railroad, with office at Pen Argyle, Pa., vice Mr. H. C. Shields, promoted.

Mr. E. R. Bissell, formerly trainmaster on the Lake Erie & Western, at Lima, O., has been appointed superintendent of the same road, with headquarters at Muncie, Ind.

Mr. A. E. Yohn has been appointed master mechanic of the Huntingdon & Broad Top Mountain, with headquarters at Saxton, Pa.

Mr. Jas. Boatwright, an engineer, has been appointed traveling engineer of

Neither theory nor practice has ever yet produced the lubricant that can do the work or take the place of

## DIXON'S TICONDEROGA FLAKE GRAPHITE

Just read, for example, what a Master Mechanic writes us :

*Gentlemen:—*

*We have made a thorough test of your grease in driving boxes and have been able to reduce our hot boxes to a minimum, since using the same. We have a locomotive that is equipped with hammered iron axles, which are full of seams and small cracks, and have been unable to run this engine more than one hundred miles without repacking boxes. Since using Dixon's Graphite Grease we have had her in continual service for two weeks without any trouble from hot boxes. I take great pleasure in recommending your grease to anyone experiencing difficulties of this kind.*

We have a very interesting Book on the whole theory and practice of Graphite Lubrication.

Ask for Booklet No. 69-C and it's yours, FREE.

SAMPLES  
ON REQUEST

JOSEPH DIXON CRUCIBLE CO.  
JERSEY CITY, N. J.

the Georgia Railroad and its branches between Augusta and Atlanta, with headquarters at Augusta, Ga.

Mr. R. N. Hudson, formerly chief engineer of the Louisville, Henderson & St. Louis, at Cloverport, Ky., has been appointed general manager of the Louisville & Atlantic, with headquarters at Versailles, Ky.

Mr. Charles E. Pugh, formerly second vice-president of the Pennsylvania, has been elected president of the Baltimore, Chesapeake & Atlantic and the Maryland, Delaware & Virginia, with headquarters at Philadelphia, Pa.

Mr. R. W. Baxter has been appointed superintendent of the Buffalo division and the Lake lines of the Lehigh Valley Transportation Company, with headquarters at Buffalo, N. Y., vice John T. Keith, resigned.

Mr. John F. Maguire has been appointed superintendent of the Wyoming division of the Lehigh Valley, with headquarters at Wilkesbarre, Pa.

Mr. George Dunsmore, one of the foremen in the Erie shops at Susquehanna, has been appointed general foreman of the Dubois shops of the Buffalo, Rochester & Pittsburgh, with headquarters at Du Bois, Pa.

Mr. John Hartung, foreman of the car repair department of the Louisville & Nashville shops at New Decatur, Ala., has been promoted to be general foreman of the car department of the Nashville-Decatur division and all branch lines of the L. & N.

Mr. A. L. Berdoc has been appointed general manager of the White Pass & Yukon Route, with headquarters at Skaguay, Alaska.

Mr. C. H. Gaunt, superintendent of telegraph of the Atchison, Topeka & Santa Fe, has been appointed assistant general manager of the same road, with headquarters at Topeka, Kan., also retaining his former position.

Mr. J. W. Walton has been appointed superintendent of the Kansas division of the Missouri, Kansas & Texas, with headquarters at Parsons, Kan., vice Mr. C. L. Harris, resigned.

Mr. William Dolbow, an engineer on the Pennsylvania Railroad at Philadelphia, Pa., was the recipient of a Christmas gift in gold from his fellow employees. The following, in the form of a little note, accompanied the gift: "It being the desire of several of the employees to show their appreciation of the kindness and generosity of Wm. Dolbow for his untiring efforts to explain to them the manipulation and maintenance of the air brake and air signal apparatus used on railroad trains, and in order to do the same, we present this token of esteem."

Mr. Edward A. Moseley, secretary of

the Interstate Commerce Commission, has been made an honorary member of the Central Railway Club, in recognition of the friendship, advice and aid he has given to organizations connected with the mechanical department of railway service.

The daily papers are making out Chauncey Newman, of Little Falls, N. Y., to be a hero. He was a crossing flagman who, in preventing another person from being struck by a train, was himself struck and badly hurt. When they were preparing to take him to the hospital Chauncey protested that he would not go until some one was sent to relieve him. He is 76 years old, but still a sound railroader.

### Niles 90-In. Driving Wheel Lathe.

Railroad managers are beginning to realize the importance of good shop facilities, and they are looking at the problem from the viewpoints of economy and of promptness in getting out work. Modern machine tools will do from two to three times the work formerly done by the older types. Take, for instance, the 90-in. locomotive driving wheel chucking lathe illustrated on the opposite page. This machine is designed for taking two cuts  $\frac{1}{2}$  in. deep, with  $\frac{3}{8}$ -in. feed at a speed of 20 ft. per minute, but in actual practice it has done much more than this. The machine is capable of turning six pairs of driving wheel tires per day of ten hours. The best practice on older types of machines is an average of scarcely more than two pairs per day, but in many shops at the present time it takes as long as from six to eight hours to turn a pair of tires.

A unique feature of the Niles driving wheel chucking lathe is the method employed for holding the work. On each face-plate are mounted four patented "sure grip" drivers. The wheels are bolted firmly against these drivers and the wedges of the drivers driven up, thus forcing the saw teeth of the driver directly into the tire. By this device the tire can be held absolutely rigid under the heaviest cuts.

The principal dimensions of the machine are as follows: Distance between face-plates, 6 ft. 8 ins. to 9 ft.; swing over bed, 92 ins.; diameter of face-plates, 90 ins. The lathe will take wheels from 50 to 84 ins. in diameter without changing the positions of the carriages. The tool-rests are of very massive design and have bases arranged so as to allow them to swivel. The feed mechanism is conveniently arranged for the operator. The face-plates are driven by internal gears and are provided with openings for the crank pins, so that wheels may always be chucked close up to the face-plates.

In order to provide for the quick removal of wheels, an independent motor

is furnished for traversing the movable head of the machine. Wheels can be put in the lathe and chucked ready for turning in from ten to fifteen minutes. The main driving motor is a 40-h.p. Westinghouse type "S" motor, having speed variation from one to two, which gives, when combined with changes by gearing, cutting speeds from 10 to 25 ft. per minute on all diameters from 48 to 84 ins. One 5-h.p. Westinghouse electric motor, type "S," is used for traversing the movable head.

The tire turning performance at the West Albany shops of the New York Central, an account of which we gave on page 36 of our January issue, was accomplished on a wheel lathe similar to this 90-in. machine.

#### Sauvage Safety Brake.

Nearly two years ago the New York, Ontario & Western began to use an addition to the ordinary air brake, made by the Sauvage Safety Brake Co., of New York, for the purpose of obtaining an increased brakeshoe pressure on the wheels. The first summer, that of 1904, it was used in passenger service, and in the fall of the same year it was decided to equip the milk cars of the road with the device. The Sauvage brake consists of a second brake cylinder so arranged that its piston will come into action when that of the first has completed about  $5\frac{1}{4}$  ins. of its stroke. This is accomplished by screwing a  $\frac{1}{4}$  in. pipe into the first cylinder at the proper

second cylinder with it. Just before the opening of the connecting pipe is uncovered a dog, that had before been held up in the stem, drops down in front of the piston rod proper; and, when the air is admitted to its cylinder, the latter catches on the dog and merely adds its push to the brakeshoes with no more movement than that required to take up the small amount of lost motion at the dog due to the spring of the parts.

As the piston rod of the Sauvage or second cylinder is connected by a lever exerting a pull of two to one on the cylinder lever at the connecting point of the ordinary piston, it is evident that the pressure exerted upon the shoes is three times as great when two cylinders of the same size are used as would be the case were the regular ordinary single cylinder to be used alone.

The advantage of this arrangement lies in the fact, that it is possible to proportion the brakeshoe pressures to the weights on the wheels. Thus, suppose a car of 60,000 lbs. capacity has a weight empty of about 31,000 lbs. If the leverages and air pressures of the first cylinder are so proportioned that a total brakeshoe pressure, equal to 70 per cent. of the weight of the car empty, is obtained; then, when the second is cut in, the brakeshoe pressure will rise to about 70 per cent. of the loaded weight. As the stopping quality of the brake on a car is practically in direct proportion to the brakeshoe pressures, the claim is made that as short a stop and

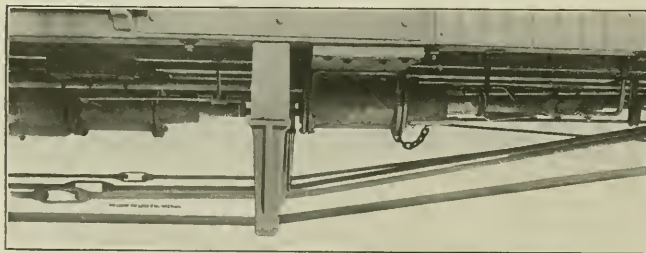

SAUVAGE BRAKE IN FULL APPLICATION.

point and leading it into the back head of this second cylinder. A stop-cock or automatic cutout cock is placed in this pipe so that the additional pressure can be used or not as may be desired. The piston rod of this second cylinder is so designed that the outer part telescopes into that at the rear and can be drawn out by the action of the first piston. The operation of the brake is that when the triple valve moves so as to admit air to the brake cylinder, it does so in the ordinary way and the piston of the first cylinder moves out. When this occurs it draws the stem of the piston of the

as efficient a control of a loaded train should be effected with the Sauvage brake as can be obtained with an empty train and the single cylinder arrangement in ordinary use.

As a matter of fact this is just what is done; though, in the case of emergency stops, the equalizing pressure between the two cylinders and the auxiliary reservoir is somewhat less than where but one cylinder is in service. This is due to the fact that some air must necessarily be used to fill in the space opened by the slight amount of travel of the Sauvage cylinder piston and amounts to about 10 lbs. That is

## The Best Books for Railroad Men

**AIR BRAKE  
CATECHISM** <sup>Price,</sup> **\$2<sup>00</sup>**

By Robert H. Blackall. 20th Edition. Contains 1500 Questions and their Answers on the Westinghouse Air Brake, which are strictly up-to-date. Includes two large Westinghouse Air Brake Educational Charts printed in colors. Gives the necessary information to enable a rail road man to pass a thoroughly satisfactory examination on the subject of Air Brakes. The author's many years' experience as Air Brake Inspector and Instructor enables him to know at once how to treat the subject in a plain, practical manner. Endorsed and used by Air Brake Instructors and Examiners on nearly every railroad in the United States. The standard and only complete work on the subject. 312 pages.

**LOCOMOTIVE  
BREAKDOWNS  
AND THEIR REMEDIES** <sup>Price,</sup> **\$1<sup>50</sup>**

By Geo. L. Fowler. Just issued. Tells how and what to do in case of an accident or breakdown on the road; includes special chapters on Compound Locomotives. Better procure a copy, as it contains 800 Questions and their Answers on Accidents and Breakdowns.

**LOCOMOTIVE  
CATECHISM** <sup>Price,</sup> **\$2<sup>00</sup>**

By Robert Grimshaw. 23d Edition. Is right up-to-date and contains twelve large Folding Plates and 1600 Questions and Answers on How to Run a Locomotive. The Standard Book on the subject, being written in plain language and free from mathematical formulae and complex problems.

**NEW YORK  
AIR BRAKE  
CATECHISM** <sup>Price,</sup> **\$1<sup>00</sup>**

By Robert H. Blackall. The only complete treatise on the New York Air Brake and Air Signaling Apparatus, giving a detailed description of all the parts, their operation, troubles, and the methods of locating and remedying the same. 250 pages.

**COMBUSTION  
OF COAL AND THE  
PREVENTION OF SMOKE** <sup>Price,</sup> **\$1<sup>50</sup>**

By Wm. M. Barr. Contains over 800 Questions and their Answers on the Science of Steam Making.

**AIR BRAKE  
CHARTS** <sup>Price,</sup> **50c.**

Showing the Westinghouse Equipment in ten colors, including freight and passenger engine. Every railroad man should possess these charts at this low price.

**A Special Circular** of any of these books sent on request. Any of these books sent pre paid on receipt of price.

**Agents Wanted  
Good Commission  
Write for Particulars**

**The Norman W. Henley Pub. Co.**  
132 Nassau Street, New York, U. S. A.

# Vulcabeston Air Pump Rings

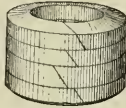

† Made for all sizes Westinghouse and New York Air Brake Pumps.

† They afford the **LEAST FRICTION, LONGEST SERVICE** and **GREATEST DURABILITY** and fit the stuffing box snugly without pinching the rod. Result: **GREATEST EFFICIENCY.**

† They are used by the largest railway systems in the country.

† Write for copy of our "Railroad Catalog."



"A Reputation Behind It"

## H. W. JOHNS-MANVILLE CO.

Manufacturers of ASBESTOS and MAGNESIA PRODUCTS, ELECTRICAL INSULATING MATERIALS, "NOARK" FUSE DEVICES, ELECTRICAL RAILWAY SUPPLIES, ETC.

100 WILLIAM STREET, NEW YORK

MILWAUKEE	PITTSBURG	KANSAS CITY
CHICAGO	CLEVELAND	MINNEAPOLIS
BOSTON	SAN FRANCISCO	LITTLE ROCK
PHILADELPHIA	LOS ANGELES	NEW ORLEANS
ST. LOUIS	SEATTLE	LONDON

to say, if the train pipe pressure is put at 80 lbs., as it is in the case of the N. Y., O. & W. milk trains, the two cylinders of the Sauvage brake will equalize at about 55 lbs., whereas a single cylinder would equalize at about 65 lbs. There is another point that tends still further to lower the brakeshoe pressures in this as in all air brake systems. It is the frictional resistance of the packings in the cylinders, and amounts to about 22 per cent. of the total pressure as indicated by the air in

record. The train pipe pressures with all of the reductions that were made in it, as well as the brake cylinder pressures, and train speeds were recorded autographically and without the intervention of the attendant.

The tests were made on regular runs of a milk train between Sidney and Middletown in order that the records might be made from work on the road and thus an average of efficiency be obtained that would correspond to what could be expected in every day service.

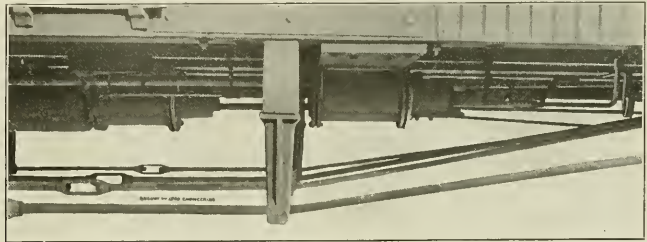

SAUVAGE BRAKE IN FULL RELEASE.

the cylinder. This is one of the reasons why pressures that seem to be so much above the standard of 70 per cent. can be used without any apparent injury to the wheels.

The application that has been made of this brake to these milk cars has taken this into account, but even then the percentage of full pressure is exceedingly high, yet it has been used successfully and satisfactorily. In fact, the brake is used untouched on both light and loaded cars with no bad effects either on the wheels, the brake rigging or the trucks. The control thus afforded in the handling of the train makes it possible to run at high speeds, even down the heavy grades with which the road abounds, with perfect safety and assurance that the train can be stopped within reasonable limits.

In order to ascertain just what could be done and make a comparison between the efficiency of the brake as applied and the single cylinder equipment, as ordinarily used, a test of a train in service was made in September last by Mr. Geo. L. Fowler, who has kindly furnished the information and data for this article.

The instruments used were autographic in nearly every particular and were adapted to register every brake event occurring during the whole course of the run, as well as the speed of the train and the location of every milepost and station. The last two points were the only ones dependent upon the action of an assistant, who was seated in the cupola of the caboose and made an electric contact at the passage of each point whose location it was desired to

Some time before the application of the Sauvage brake, it had been decided to raise the leverage on these cars at the cylinder lever, whose arm lengths were changed from 8¼ ins. and 15¾ ins. to 10 ins. and 14 ins., thus raising the apparent percentages of brakeshoe pressures from 63 to 83 per cent. of the weight of the empty car, an increase of about 36½ per cent. It was, therefore, decided to use this leverage on all the runs but one that were made with the single cylinder and this one was made with the standard leverage of 8¼ ins. to 15¾. With the Sauvage brake in operation and the brake equalizing at 55 lbs., the calculated pressures on the brakeshoes amounted to 99.59 per cent. of the weights of the loaded cars. These milk cars weighed, empty, from 37,500 to 41,000 lbs., with an average of all of those used of 38,850 lbs. The average weight of the lading of ice and milk was 34,760 lbs. These cars were hauled in trains of from eight to ten cars at speeds rising, at times, to more than 60 miles an hour.

Arrangements were made for a certain number of emergency stops at designated places on each day's run, so that a comparison between the two types of equipment could be made for that class of work. As would naturally be expected, the higher brakeshoe pressures used with the Sauvage brake resulted in shorter stops. For example: On September 8, at milepost 163, the Sauvage brake made a stop from 60 miles an hour on a down grade of 74.45 ft. to the mile, in 2.17 ft. The single cylinder brake with the high leverage made a stop at the same place from 62.8

miles per hour in 3,176 ft., and with the standard leverage from 60 miles an hour in 4,496 ft. The track conditions as well as the weight of the train were the same for each.

These figures may be taken as representative of the average of all of the stops and runs that were made. In other words the stops are about cut in two as compared with the use of the standard leverage and reduced in reality about 27 per cent. as compared with the high leverage. These tests showed further that the high leverage was impracticable for the service on account of its tendency to cause skidding, since 28 pair of flat wheels were reported as the result. Hence the true comparison should be made with the standard leverage.

#### Transmutation of Shonts.

The poet Burns says, "the king can make a belted knight, a marquis, duke, and all that, but an honest man's above his might," etc. Some of Theodore Roosevelt's successes make us wonder if he could not make "an honest" man out of unpromising material. This thought has come to us in connection with the transmutation of Theodore Shonts, chairman of the Isthmian Canal Commission. Before he was appointed to his present high position Mr. Shonts was a railroad manager who had dis-

appreciate his responsibilities. It is a great pity that President Roosevelt did not see fit to appoint a capable man like Engineer Wallace to the position of chairman of the Isthmian Canal Commission, for then he would have had

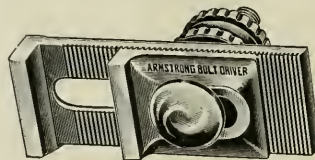

DROP FORGED BOLT DRIVER.

engineering skill combined with business capacity. Shonts as the head is an expensive and ghastly joke.

#### Bolt Driver.

A handy shop appliance has recently been got out by the Tool Holder People, as the Armstrong Brothers Tool Company, of Chicago, are often called. The appliance is a very convenient bolt driver for use on a lathe. Our illustration shows what the appliance is and how it works. It is easily adjusted, and fits any lathe, and it is a time saver as well. By means of the extension washer between the face plate and the driver body, the position of the driver can be adapted to use with centers of varying length. The toothed surface takes the strain off the parts and the business of the bolt and nut is simply to hold things in place. Wear is thus reduced, and the whole thing is neat and efficient.

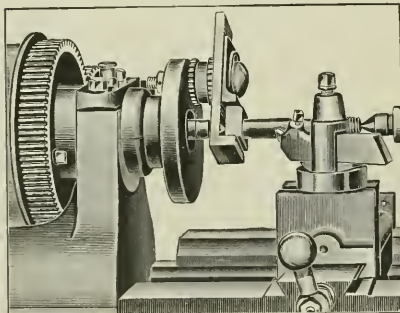

BOLT DRIVERS ON A LATHE.

played no ability except for selling railroad property. He had no technical or engineering training, and very little experience in practical railroad operating; his experience or ability was not such as would command a job as a head brakeman; yet, under the order of President Roosevelt creating him chairman of the Isthmian Canal Commission, Mr. Shonts flashes into a recognized authority on business and engineering questions that age, training and experience hesitate to tackle.

In our opinion, Mr. Shonts as head of the Panama Canal Commission is a bluff, and the cool, pretentious way that he talks of difficult engineering problems indicates that the man does not

#### Perfected Locomotive.

The Empire State Express, on the New York Central, has made us all familiar with engine 999, and Kipling has described the engine known as "decimal-nought-nought-seven," and Eli Gilderfluke has given to the world the perfected locomotive .00009. A representation of this famous engine with all the crank motions up to date has been used as the headline illustration on our club-raisers' poster for 1906. Skeevers said about a certain fireman that he had learned a lot of things about a locomotive that are not so, and we are afraid that Gilderfluke's locomotive contains a lot of contrivances that are not there. For instance, notice the device for altering the length of the crank. Then there is the Dustiscope, an appliance which the inventor thought was of great importance, for Eli never was a waster and that accusation never could be proved against him. Look at the engraving of his en-

# GOLD Car Heating and Lighting Co.

Manufacturers of

**ELECTRIC,  
STEAM AND  
HOT WATER  
APPARATUS  
FOR RAILWAY CARS**

**EDISON  
STORAGE  
BATTERY  
FOR RAILWAY CAR  
LIGHTING**

Catalogues and Circulars  
cheerfully furnished

Main Office, Whitehall Bldg.  
17 BATTERY PLACE  
NEW YORK

# Homestead Valves

Straightway, Three-way and Four-way, and

# Homestead Locking Cocks

Are Famous the World Over

They cost more, but are worth very much more than other makes. You try them and see.

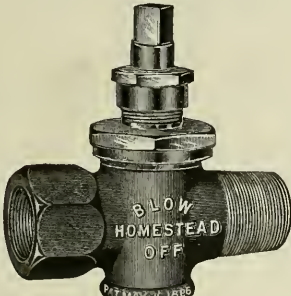

Brass, 1 1/4 in., \$6.00 net

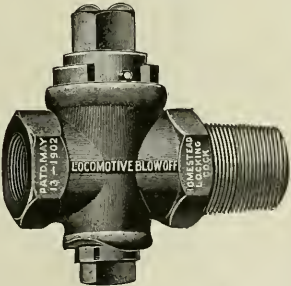

Iron Body. Brass Plug, 1 1/4 in., \$4.00 net

## Homestead Valve Mfg. Co.

WORKS, HOMESTEAD, PA. PITTSBURG, PA.

## American Locomotive Sander Company

13th & Willow Sts., Philadelphia, Pa.

Proprietors and Manufacturers

LEACH, SHERBURNE, DEAN, HOUSTON, "SHE" and CURTIS SANDERS

### THE ROBERT W. HUNT & CO.

Bureau of Inspection, Tests and Consultation, 1137 THE ROOKERY, CHICAGO.

68 Broadway, New York. Park Building, Pittsburgh. 31 Norfolk House, London, Eud.

Inspection of Steel Rails, Splice Bars, Railroad Cars, Wheels, Axles, etc. CHEMICAL LABORATORY—Analysis of Ores, Iron, Steel, Oils, Water, etc. PHYSICAL LABORATORY—Test of Metals, Drop and Pulling Test of Couplers, Draw Bars, etc.

Efficiency Tests of Boilers, Engines and Locomotives.

gine the next time you are in the round-house and see for yourself. It is sometimes about as important to know what won't work and never would, as to know what will, because such knowledge often prevents time and thought going to waste. Gilderluke's effort to do everything on the same machine is worthy of careful thought, but is a thing to be avoided.

### Boring Attachment for Lathe.

This attachment is for the purpose of practically converting a lathe into a horizontal boring mill, and when so converted the lathe is said to equal within its range the output of a mill both in quality and quantity. The attachment which we here illustrate can be made for any size lathe. It consists of a lower plate with an angle projecting down and fastened to the back of the carriage. The surface of this angle plate is planed true with all the other parts of the attachment. The fastening device has a slide well fitted and planed true and it also has an adjusting screw for elevating the bed for holding the work.

For a 30-in. lathe the bed has three T-slots which will take 5/8-in. or 3/4-in. bolts. It is 31 ins. long, 22 1/2 ins. wide,

gle pieces which have been previously bolted on the front of carriage, are firmly attached to the table by two screws, which may be seen in our illustration, and these hold the bed to the lathe carriage. It can readily be understood that this arrangement gives a true adjust-

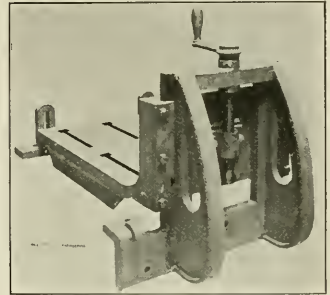

LATHE ATTACHMENT FOR BORING.

able bed, equal to any well designed machine tool for holding pieces to be bored.

There is no blocking up, nor have any other slow methods to be resorted to when using a lathe for this kind of boring. Using this device, it takes a very

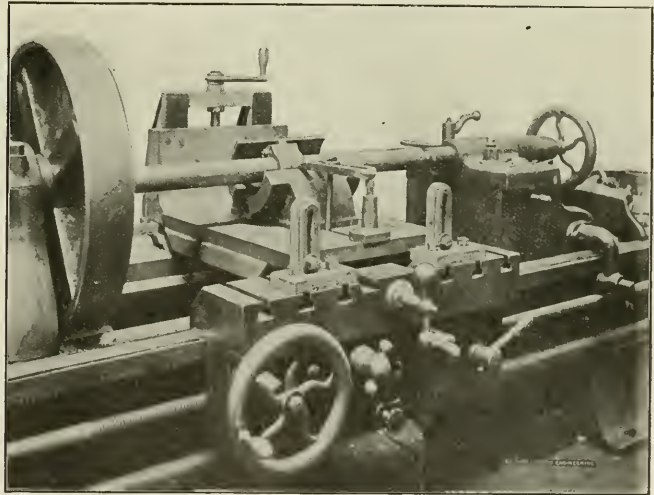

LATHE TEMPORARILY CONVERTED INTO A BORING MILL.

and has 5/2-in. vertical adjustment. When set on the lathe carriage as shown, it is true with the carriage in all directions. On the upward projection it is planed true, so that work can be set quickly and a place to measure from and set in line with the lathe spindle. By the vertical adjusting screw the table can be either raised or lowered parallel with the lathe shears. After being brought in position, the two slotted an-

short time to make the change for boring; all that is necessary is to remove the tool slide, and drill and tap two holes in the back of the carriage, lift the device on, and in a few minutes it is ready for work. In practice a 3-in. or 3 1/4-in. diameter bar, with suitable cutterheads and automatic feed, is desirable, with one end of the bar attached to the face plate of the lathe, the other end carried in steady rest or other bear-

ing; one can thus easily have practically a powerful boring mill, and the operator does not depend on the lathe centers, which would be the weakest part of this kind of boring. It forms a handy and useful attachment for any shop. Its weight for 30-in. lathe is 685 lbs. The device is made by H. B. Underwood & Co., of Philadelphia, and it is worth anyone's while to look into this matter and get a good idea of the possibilities of this boring attachment.

A neat calendar for the year of grace 1906, of the panel type, has been issued by Green, Tweed & Co., of New York. We call it a panel, because it is eleven inches wide by about 2 ft. 3 ins. long and is printed in three colors. The months, as shown on the calendar, are printed each on the representation of a spool of Palmetto Twist for small valve stems and are in black letters on a red ground. The company say that the time to use the packing is every month in the year, and they show the Palmetto packing for locomotive air pumps as it looks when it is turned out by the factory. The company give a sample of the air pump packing to those who write and ask for one, and they give away a calendar for this year on the same terms. Try them for both. The articles are worth asking for.

#### Straight Through.

A story is told which illustrates the feeling of reflected glory which filled the breast of a certain porter on the "Second Empire" train on the New York Central. This porter was thus far worthy of his hire, that he admired with all his heart the "get there" characteristic of this train. A polite stranger, evidently unfamiliar with the time table or even with the aims and objects of the said train, enquired as they sped along if the train stopped at Fonda.

"This train stop at Fonda?" queried the porter, with evident indignation in his voice and with the air of a man who desires the enormity of the whole terrible thing may soak completely into him. "This train, the Second Empire, No. Sah. No Sah, this train does *not* stop at Fonda; it doesn't even hesitate at it."

Bulletin No. 2 is a most excellent example of the printers' art, and the photographers' and artists' dexterity. It is of standard catalogue size, like the Railroad Club proceedings, and in it the Consolidated Railway Electric Lighting and Equipment Co. of New York tell you all about the axle light system. In it are to be found general instructions for the installation of the equipment, the wiring and the battery. Clear line cuts illustrate the various parts, and half-tones, which leave little to be desired,

show how the generator is carried on the truck, the construction of the regulator and the grids of the storage batteries. The bulletin has 32 pages and the description of the apparatus and of how it works is complete. This treatise should be in the hands of all those who have to do with the axle light system, and it can be used as a primer by those who want to find out something about this method of changing moving into radiant energy. Write direct to the company for a copy.

Some friction between the firemen on the Lackawanna system and the management excited some fears that there might be a strike among the firemen last month. The process of reasoning together, so much commended by the late Chief Arthur, brought about a settlement satisfactory to both sides. The firemen are said to have obtained 77 per cent. of their demands.

#### Good Gasket.

The use of increased steam, water, air and gas pressure has, as a matter of course, called for improvements in joint connections, and the subject has been the object of much thought and study by experts, especially in the matter of gaskets. Such joints must be absolutely air, water and gas tight under any pressure, and they must further possess the quality of being easily and quickly made and taken apart, and the joint should be as thin as possible. When made and in working order the joint should not leak when cold or hot or from unequal expansion, and should not cause electrolysis; that is, no electrical action should be set up which would cause any eating away of the parts.

On iron pipes a gasket composed of iron has been found to make an exceedingly good joint, and a gasket coated thinly with a special iron cement that appears to fill these requirements and is said to make the thinnest and strongest gasket in use and to be the nearest to a ground joint. It is claimed that such a joint is as durable as the pipes it connects, as well as one of the cheapest forms of gaskets. The slight expansion found in smooth-on gaskets makes connections tight and strong, and this principle does not exist in some of the material commonly used for such purposes. Joints made with the smooth-on packing are ready for use as soon as completed and can be taken apart when necessary and the same gasket may be used again, or may be laid aside for future use. This form of gasket is made by the Smooth-On Mfg. Co., Jersey City, N. J.

## Locomotive Blow-Off Plug Valves

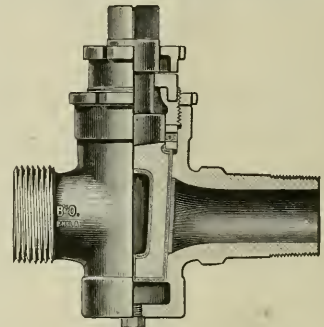

Fig. 9.

All Brass, extra heavy, with Cased Plug. For 250 lbs. pressure. Made with Draining Plug to prevent freezing.

## Locomotive Gauge Cocks

For High Pressure

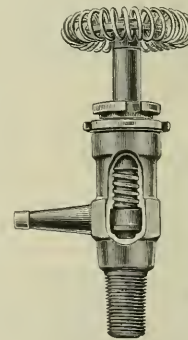

Fig 23, with Wheel.

Bordo Self-Grinding Gauge Cocks, made with renewable Hard Bronze Disc. Opened and closed with a quarter turn. Guaranteed Steam tight under the most exacting conditions. Shanks Threaded to specifications for Locomotives.

## Swing-Joints and Pipe Attachment



Fig. 33.

May be applied between Locomotive and Tender. These Swing Joints are suitable for Steam, Gas, Air, Water or Oil.

Complete Booklet on Application

**L. J. BORDO CO.**  
PHILADELPHIA, PA.



**MACHINIST LIBRARY**



**Rogers'**

**ROGERS' DRAWING AND DESIGN FOR SELF INSTRUCTION.**

**\$7**

**1 Monthly**

Each Volume is complete in itself and may be obtained separately.

**LIST**

- 1. Rogers' "Drawing and Design" 53.00
- 2. Rogers' "Progressive Machinist" 2.00
- 3. Rogers' "Advanced Machinist" 2.00

**READ CAREFULLY**

The books composing the library are intended to be educational and progressing from the simple to the more complex subjects; plain books for those already engaged, or soon to be, in the practical application of the theory of mechanics; each volume is complete in itself, while progressive in the series. The books are each supplied with a ready reference index, which enables the quick use of their contents.

The volumes are strongly and handsomely bound in black cloth, with titles and edges in gold; they contain 1,204 pages, 1,244 illustrations, many of which are full pages, with 3,600 ready references; they are printed on fine surface paper with large clear type. Each book stands 8½ inches in height, and the three packed for shipment weigh over 7½ lbs. No works of equal value have ever been offered to the machinists' and allied trades, and no one from the superintendent and owner to the apprentice can afford, considering the price and terms, to be without them.

**1 DOLLAR MONTHLY**

The three volumes will be forwarded postpaid to any reader of

RAILWAY AND LOCOMOTIVE ENGINEERING who sends to us one dollar and a written promise (see coupon below) to pay the balance of the purchase price in six monthly installments of one dollar each, making \$7.00 in all.

**SHIPPING DIRECTIONS**

Date.....  
I enclose \$1.00 (one dollar) to apply as first payment on one set of

**ROGERS' MACHINIST'S LIBRARY**  
which ship at once to the following address, all charges prepaid. I hereby agree to remit by mail at the rate of one dollar each month, the remaining six (6) dollars.

Signature.....  
Occupation.....  
Where employed.....  
Residence.....  
City.....  
Railway and Locomotive Engineering.

**THEO. AUDEL & CO.**  
Publishers  
63 Fifth Avenue New York

**Rotary Thread Rolling Machine.**  
In the machine which we here illustrate, the threading dies, instead of being of the reciprocating type, are composed of one rotary or revolving die, which runs continuously in one direction, and one segmental die which remains stationary after it is adjusted for the work. The bolt or piece that is to have

putting them in tension; and these springs keep the dies in pitch. As the bolt enters and the rolling begins at different points on the dies, the breaking down, or the beginning of the thread is not confined to one particular place, so that the wear is general and uniform over the whole die surface. The dies admit of fine adjustment for any required size of work, or to compensate for wear.

The comparative merits of cut and rolled threads are well known generally by engineers; still it may be of interest to give the result of a recent test of the two forms of thread, the material in both cases being machine steel: One bolt, 1¾ ins. diameter, by 24½ ins. long, with cut thread, had a tensile strength of 88,900 lbs. and another bolt, 1½ ins. diameter by 24½ ins. rolled thread, when pulled, showed a tensile strength of 95,850 lbs.

The rolled thread is, of course, not adapted for every purpose, still these tests show that where it may be used there is a great gain in strength and a consequent saving of weight and cost. The saving in weight of material is about 20 per cent.; that is to say, material 20 per cent. lighter than would be used if the threads were to be cut, may be used if the threads are to be rolled, and there will be no loss of strength. There is also a gain in time, at least twice as many bolts may be rolled as can be cut in the same period.

These machines are made in two sizes, the 1 in. machine is complete with countershaft, wrenches, and five pairs of dies, for bolts of ½, 5⁄8, ¾, 7⁄8 and 1 in. in diameter. The weight of this machine is

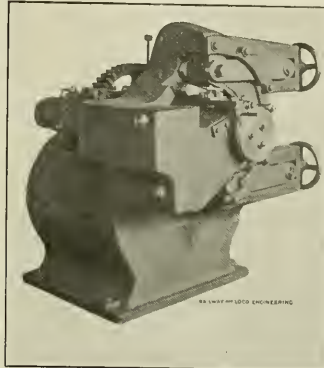

ACME THREAD ROLLING MACHINE.  
Front View.

the thread rolled on it is passed between the two threading dies and carried around with the rotating die, which is mounted on the main shaft or spindle.

Our illustrations make clear the general construction of the machine. The adjustment of the distance between the two dies is effected by means of the hand wheels. The segmental die is carried in a heavy block that is eccentric to the shaft, and by loosening one of the hand wheels and tightening the other the adjustable die is advanced or withdrawn from the rotary one.

When operating the machine, the bolt is placed in the jaws, then the operator starts the rotation of the machine by moving a handle which extends out from the feeding carriage. This handle is shown in the half-tones and drops the pawl into engagement with the notched disk, which carries the oscillating carriage forward and passes the work between the dies, the rolling beginning at once, and the jaws then opening automatically and allowing the carriage to drop back by its weight to the feeding position again.

There are four opportunities for feeding in every rotation of the die, as there are four notches in the disk. The bolt or rod is fed into the machine horizontally so that bridge rods, car truss rods or other work of almost any length may have threads rolled on the end. The heavy, compact construction of the machine enables it to be built so as to roll threads on large sized bolts or bars. At the rear end of the main spindle there are two spiral springs with means for

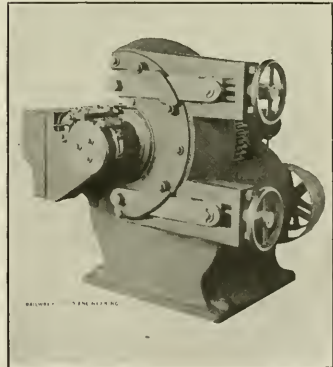

ACME THREAD ROLLING MACHINE.  
Back View.

about 10,000 lbs., and the floor space it occupies is 4 ft. 10 ins. by 6 ft. 6 ins. The 2 in. machine is also complete with countershaft, wrenches and five pairs of dies, which run from 1. 1¼, 1½, 1¾ and 2 ins. The weight of the larger machine is about double that of the smaller, and the floor space for either machine is

about 7x9 ft. The tool, which will no doubt become very popular, is made by the Acme Machinery Company, of Cleveland, Ohio.

#### Traveling Engineers' Circulars.

The Traveling Engineers' Association, whose object is to improve the locomotive engine service of American railroads, has issued a circular of enquiry concerning a most important subject. It is on "Care of locomotive boilers at terminals and while in service." There are twelve questions asked, and if these are intelligently answered by those who are competent to do so, a valuable report will no doubt be prepared. Communications on the subject should be sent to Mr. F. P. Roesch, 1433 Chicago Road, Chicago Heights, Ill. Members have also been requested by Mr. Frank Burke, of the Duluth, Missabe & Western, at Proctor, Minn., to give him any information they may possess concerning the operation and maintenance of the latest makes of lubricators, hydrostatic and mechanical, for valves and cylinders on engines using saturated and superheated steam.

#### Wrong Kind of Track.

Three dogs were killed by the Knoxville express, and the owner of the dogs sued to recover damages. The court refused on the ground that the dogs were guilty of contributory negligence. The decision is wise, because the owner of the dogs had neglected to teach the dogs the difference between the track of a fox and the track of the Chattanooga flyer. A cow catcher is not a dog catcher, and dogs are usually charged as freight on all roads. The unfortunate Tennessee dogs might have been properly classed as perishable freight. Notices are sometimes posted at public places that no dogs are allowed, but they cannot be of any service until dogs are taught to read.

The Hendrick Manufacturing Company, of Carbondale, Pa., have issued their first catalogue on Perforated Metals and it is a very creditable and comprehensive work. There are sixty pages of text interspersed with numerous illustrations of standard and special screen plates, spark arrester plates, revolving screen, sections, etc., as well as various styles of elevator buckets, conveyor lining, troughs and flights, manufactured in their sheet iron and steel construction department. There is in addition data in the way of engineering tables which make the catalogue valuable for reference purposes. These tables include the weights of sheet and plate steel, decimal equivalents of six wire gauges used in the United States, comparative table of decimals and common fractions and a table of the circum-

ference and areas of circles. The company will be happy to send a copy to anybody who will write to them for one.

#### Circulation Shows Health.

The circulation of RAILWAY AND LOCOMOTIVE ENGINEERING on December 30, 1905, was 18,461 copies, of which between 95 and 96 per cent. was paid. This statement was duly sworn to by the secretary of the Angus Sinclair Co. This is the plain fact, and as a good circulation is an evidence of health, RAILWAY AND LOCOMOTIVE ENGINEERING can certainly claim to be in a robust condition. The paper goes to and is read by general managers of railways, purchasing agents, mechanical engineers, master mechanics and shop foremen, and these men are the ones who recommend or influence the purchase of supplies. The paper also goes to locomotive engineers, firemen, roundhouse men, the shop staff, and repair men of all grades. These men, though they do not sign requisitions, nevertheless influence the purchase of goods, because they say how things work, and express their opinion of supplies so emphatically that it generally reaches the man higher up. All these men, high and low, can be reached through the columns of RAILWAY AND LOCOMOTIVE ENGINEERING, and in no other way.

A calendar for 1906 printed in a number of colors has been received at our office. It is issued by the J. A. Fay & Egan Company, of Cincinnati, Ohio, who are widely known as makers of wood working machinery. A fine view of their works is given and the margin of the picture is embellished by representations of the medals received at various international exhibitions. The sheets giving the months of the year are white and the figures are in plain block type. The Sundays and holidays are printed in red, and with the other colors used throughout the effect is striking. It is a good office or shop calendar and the company will be happy to send you a copy if you write and ask for one.

A marvelous display of atmospheric reflection peculiar to the Alps was witnessed the other day by passengers in the Paris-Frankfort express. Shortly after leaving Metz a wonderful panorama developed in the horizon on the western side. The sun seemed to light up the whole Alpine chain, the great mass of Mount Blanc stood out clearly marked, its sides covered with snow and its glaciers reflecting the sunbeams. At one moment the Lake of Geneva was visible, its water tinged a greenish blue. The mirage faded only at sunset, as the train neared Faulquemont. It had lasted about twenty minutes.—Montreal *Witness*.

# Tate Flexible Staybolt

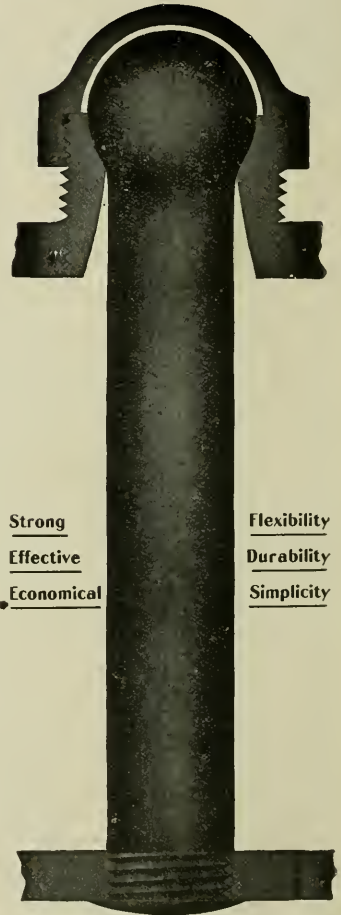

Strong

Effective

Economical

Flexibility

Durability

Simplicity

Holds firebox sheets securely together, and accommodates itself to the unequal expansion of the plates.

## FLANNERY BOLT COMPANY

PITTSBURG, PA., U. S. A.

Suite 308, Frick Bldg.

B. E. D. STAFFORD, - - General Manager

Write us for Reference Book

**STANDARD MECHANICAL BOOKS  
FOR ROAD AND SHOP MEN  
BY CHAS. McSHANE**

**The  
Locomotive Up to Date**

Price, \$2.50

**New York and  
Westinghouse Air Brakes**

Price, \$1.50

**One Thousand Pointers for  
Machinists and Engineers**

Price, \$1.50

All books bound in fine cloth

AGENTS WANTED everywhere; write for terms and descriptive circulars. Will be sent prepaid to any address upon receipt of price.

**GRIFFIN & WINTERS  
171 La Salle Street, CHICAGO**

**Wm. R. Phelps & Co.**

MANUFACTURING JEWELERS.



High Class Watches, Diamonds, and other Precious Stones.

We make a specialty of Masonic and all other Emblems.

Diamonds purchased of us at present prices are a good investment. We have a fine line of the best Railroad Watches at rock bottom prices. Jewelry of every description.

**WM. R. PHELPS & CO.**

3a MAIDEN LANE, NEW YORK, N. Y.

**Portable Hydraulic Press.**

Have you ever heard a man say he was "hung up" over a piece of work? If you have you no doubt rightly understood him to mean that his activity in a particular matter had been suspended for some reason or other. In our sketch we show a Watson-Stillman hydraulic jack which is hung up the whole time over a job and yet does business very effectively in the way of pressing brass bushings into locomotive side rods and also still being hung up, it presses driving brasses into boxes or does any similar piece of work where steady, strong pressure has to be applied.

The apparatus is used in the West Washington street round house of the

Joining these two heavy cross bars and on their lower side is a follower taken from the draw gear of some disabled car and from this follower hangs an ordinary Watson-Stillman hydraulic jack in good working order. The handles of the jack do not lie idle, for to them are attached chains which run up and over a pair of small sheaves and at the ends of these chains counterbalancing weights are suspended so that when the jack has been run out in doing a piece of work it can be pulled up again to the original "hung up" position. There is a gauge on the jack which registers the pressure applied and by which the operator can tell what he is doing with this portable hydraulic press, for that is what the apparatus is when all is said and done.

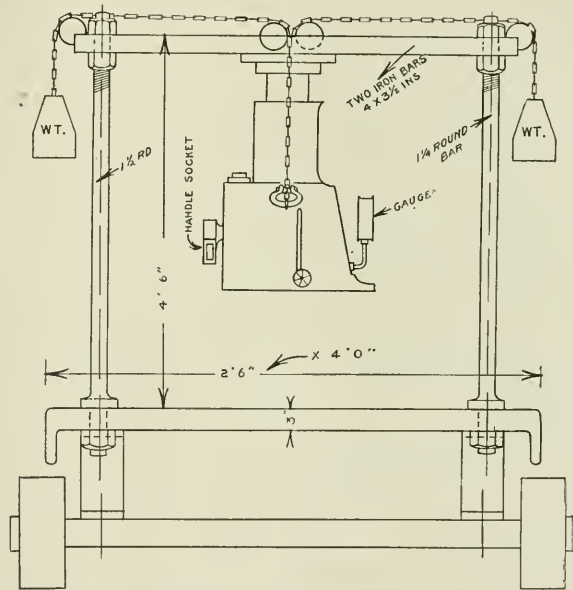

HOME-MADE PORTABLE HYDRAULIC PRESS.

Big Four, at Indianapolis, of which Mr. T. F. Griffin is the general foreman. It consists of a flat table of cast iron about 3 ins. thick and 2 ft. 6 ins. wide by 4 ft. long, ribbed on the sides, and mounted on a couple of pair of wheels and supplied with a handle for pulling it about the shop. Four upright bars, 1 1/2 ins. diameter, are let into the flat table, each has a collar on the upper side; the bars are secured with nuts below the table. The upper ends of these four upright bars or pillar bolts, as they might be called, are threaded at their tops and they support and hold two bars of iron about 4 ins. wide by 3 1/2 ins. high, and these stand across and above the table, and are at a distance of 4 ft. 6 ins. from it, and they are about 8 or 10 ins. apart.

One has sometimes seen men at a wreck place jacks under an engine and proceed to work them, and if there has been much rain, or if on soft ground, the result has been the unprofitable process of jacking down the ties instead of raising the engine. This jack also does all its work downward. The ram or plunger in this case is fast and the base is the part which moves, but relying on Newton's third law of motion, which practically states that action and reaction are equal and opposite, this hydraulic, notwithstanding the fact that it is constantly hung up over the job and is always compelled to jack downward, gets there with its foot; if it had two, we would have said that it got there with both feet.

# THE UNION SWITCH & SIGNAL CO.

Consulting and Manufacturing  
Signal Engineers

Automatic Block Signals—Electric  
and Electro-Pneumatic

Interlocking—Electric, Electro-Pneu-  
matic and Mechanical

Electric Train Staff Apparatus

GENERAL OFFICES AND WORKS AT  
SWISSVALE, PA.

DISTRICT OFFICES:

New York: 143 Liberty Street

Chicago: Monadnock Block

St. Louis: Frisco Building

## The Twentieth Century Master Mechanic

Won't use Solid Mandrels.  
Cost too much, take up too  
much room and don't give  
satisfaction.

Nicholson  
Expanding Mandrels

Take everything from 1 to 7  
inch holes. Take up little  
room—always ready and  
you can buy four sets for  
the cost of one of the solid  
kind.

Are You Using Them?

Catalogue tells you  
more about them.

W. H. Nicholson & Co.  
Wilkesbarre, Pa.

### Defense of Private Car Lines.

When the so-called trusts and monopolies are assailed by politicians or the press, their representatives generally distinguish themselves by the exercise of golden silence. That, however, is not the policy of J. Ogden Armour, the real head of the beef trust, for he very ably stated his side of the case through the columns of the *Saturday Evening Post*. Nearly everybody accepts the denunciation of trusts and monopolies as true without investigating the merits of the interests abused. Those familiar with railroad business are aware that the immense business of transporting fruit and other perishable products from the producer to the consumer would never have been accomplished by railroad companies without the capital and co-operation of line car owners. Here are a few of the points made by Mr. Armour:

"The Armour private car is not used as a device to secure, directly or indirectly, rebates, discriminations or concessions to the car line owning it, to the shipper using it, to the individuals—or any one of them—owning the Armour Car Lines, or to any individual near or remotely connected with the industry. It was determined when the prohibitive law against rebates went into effect it was to be obeyed and not evaded; that a policy of indirection and evasion was a poor policy from any standpoint and would not be countenanced by the Armour interests.

"That there is a considerable difference of opinion between the Interstate Commerce Commission and the railroads, relating to the transportation of property from interior cities of the United States upon a through tariff over railroads and steamships to foreign countries, is undeniable. The situation has provoked much comment. However, it is not clearly determined whether the matter is within the province of the Interstate Commerce Commission act and that of the Interstate Commerce Commission. The fact is that the recent indictment of railway and packing officials at Kansas City for alleged rebating relates exclusively to shipments from Kansas City to Europe. Speaking for my own company—the regular established, public rates have been paid in full; and there has not been 'any rebate, concession or discrimination' of any character to shippers in this relation."

"Only the commonest kind of selfish common sense is required to arrive at the policy of keeping these refrigeration rates down to a point that will foster the fruit and berry industry and stimulate it to the broadest possible expansion. Any line of action less liberal than this would be short-sighted and suicidal."

## Suppose You Were Called for An Examination

For a license, to-day, where would you stand? Would you pass or not, in your own mind? A Good Prime Move on your part is to get busy with a copy of

### Spangenberg's Steam and Electrical Engineering

which contains nearly 700 pages of the knowledge you will have to have to pass a successful examination. \$3.50. Money back if not satisfied.

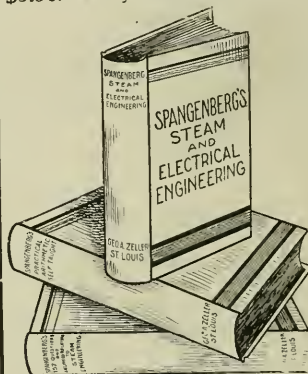

The only book ever published containing 1035 Questions and Answers, with illustrations specially drawn for this work.

CUT OUT AND MAIL TO-DAY  
GEO. A. ZELLER BOOK CO.  
19 S. 4th Street, ST. LOUIS, MO.

I accept your offer to send me, express prepaid, one of Spangenberg's Steam and Electrical Engineering, price, \$3.50, and enclose \$2 as first payment. The balance, \$1.50, I agree to remit in 50-cent monthly instalments, money or express order, or stamps.

Name.....

Street or Box No.....

City and State.....

## Patents.

GEO. P. WHITTLESEY  
McGILL BUILDING WASHINGTON, D. C.  
Terms Reasonable. Pamphlet Sent

## Molding Machines

Vertical Vibration. Power Draft  
ALL KINDS OF MACHINES

THE E. H. MUMFORD CO.,  
17th & Callowhill Streets, PHILADELPHIA, PA.  
J. W. JACKMAN & CO., Ltd., 59 Victoria St., London, S.W.

# THE DUKESMITH School of Air Brakes

MEADVILLE, PA.

gives a full course of instruction in both the Westinghouse and New York Air Brake Systems, including all Text Books and colored charts, for

## Only \$10

Terms, cash or partial payments. Send us your address and we will mail you full particulars.

This is the first time railroad men have ever had an opportunity of getting a complete air brake education for a nominal sum. Write to-day.

The Dukesmith School of Air Brakes,  
MEADVILLE, PA.

F. H. Dukesmith, A. B. E., Director.

# World's Fair

St. Louis

FIRST PRIZE FOR

# TOOL STEEL

AWARDED TO

McInnes Steel Co.

CORRY, PA.

in competition with the best makes in England and Germany. Also manufacturers of all kinds of Tool Steel, Die Blocks, and Steel Forgings.

Write for Prices and Information

The private car system "is the only logical agency by which the fruit business can be handled," avers Mr. Armour and the "exclusive contract," which gives the Armour cars, for example, a monopoly of the business on any particular road, "is the only logical basis upon which the private car can be operated."

A laborer was recently engaged in a railway yard in the East. He was set to carry some heavy planks. After a couple of hours' work he went to the foreman and said: "Did I tell ye me name when I started?" "Ah, mon, ye did; ye said it wor Tamson." "Oh, that's a' richt, then," replied the man, wearily. "Ah was wunnerin' if ye thoct Ah said it wos Samson."

A catalogue of extra heavy valves has been issued by the Jenkins Brothers, of New York. The valves described are for use in pressures above 150 lbs. They include globe, check, Y and angle valves made wholly of brass or with iron bodies. Good half tones illustrate the valves made and sizes and prices are given in the letter press. If you are in want of information concerning such valves write the Jenkins Brothers for a copy of the catalogue and for any other information on the subject.

In the course of a paper presented to the American Institute of Mining Engineers on car axles, by Dr. C. B. Dudley, the statement is made that iron and steel do not behave alike when subjected to bending stresses. A well made iron car axle the metal of which will show in tensile strength from 48,000 to 52,000 lbs. per square inch will stand successfully the same fiber stress as steel of 80,000 to 85,000 lbs. tensile strength.

The Canadian Railway Club had a treat at their last regular meeting held in Montreal. Mr. A. A. Goodchild, Auditor of Mechanical Accounts, read a paper on "Railway Statistics," and closed with a clever skit in verse, from which we extract the following stanza: "What is the weight on the driving wheels, what power goes up in the stack? How much sand is used on the rails, when there's slippery ice on the track? What pressure is on the air brakes, what resistance in the air? Was ever problem so abstruse—to make you tear your hair?"

At a recent meeting of the New England Railroad Club an able paper on "Terminal Car Cleaning" was read by Mr. Edward F. Bigelow. A suggestion was warmly approved that the work of car cleaning should be superintended by an experienced painter.

# ALDON CAR and ENGINE Replacers

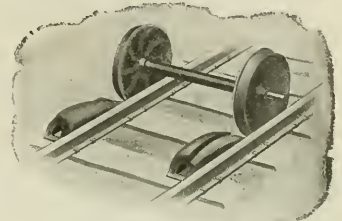

Sure, Safe and Quick Rerailing. A Wedge Without Moveable Parts. Slope so as to Clear Brakes on Sand Pipes. Rights and Lefts—Steel or Malleable Iron.

The ALDON COMPANY

1103 Monadnock Block  
CHICAGO, ILL.

# SKAT

Best Hand Soap Known

UNEXCELLED for taking the SMUT and GREASE off RAILROAD men.

AGENTS WANTED

An attractive offer awaits the first man in every town who answers this

SKAT MFG. CO.  
791 Park St. Hartford, Conn.

# Flexible Spout

Vertically in straight line. Also laterally. The latest Improvement to

# Poage Water Columns

American Valve and Motor Company  
CINCINNATI, OHIO.

SEND FOR CATALOGUE

# Locomotives, Freight and Passenger Cars

All equipment rebuilt in our Chicago shops, and at Scranton, Pa., in the new "Lackawanna" Shops

## All Kinds of Cars and Engines Ready for Immediate Delivery

RELEASED BY TRUNK LINES

1000—60,000 LBS. CAPACITY REBUILT FLATS AND GONDOLAS  
 2000—50,000 LBS. CAPACITY FLATS, BOX AND GONDOLAS  
 COACHES, COMBINATION AND BAQDAQE CARS  
 FOREIGN SHIPMENTS HAVE PROPER CARE OF  
 EXPERIENCED STAFF

Cable Address  
 "FITZLUTH"

55 AND 70 TONS CONSOLIDATIONS  
 45 AND 50 " 10-WHEELERS  
 40 TO 55 " MOGULS  
 45 TO 50 " PASSENGERS  
 SWITCHERS, FORNEYS AND SHAY ENGINES

**FITZ-HUGH, LUTHER CO.,** Monadhock Block, CHICAGO  
 141 BROADWAY NEW YORK      CHEMICAL BLDG. ST. LOUIS      80 ST. FRANCIS XAVIER ST. MONTREAL, CAN.      RIALTO BLDG. SAN FRANCISCO

### It Ends in Smoke BUT IS GOOD WHILE IT LASTS

If you are a judge  
 of cigars try the

## Lordly Edwin

Conchas Size  
 All Havana

They measure 4½ inches  
 over all. Fit any mouth  
 and suit all tastes.

We sell them \$5.40 per  
 hundred or \$2.70 for box  
 containing fifty.

The Edwin Lord  
 Cigar Company

64-68 W. 125th Street  
 NEW YORK

Send for booklet, "Tricks of the Cigar Trade Exposed"

### Come Early and Avoid the Rush.

We have on hand at the present time a limited number of the bound volumes of RAILWAY AND LOCOMOTIVE ENGINEERING for the year 1905. Those desiring to secure a copy can do so by sending us \$3.00, express money order preferred. The book is neatly bound in brown cloth and it forms a very useful volume for reference and is always pleasant and instructive reading. RAILWAY AND LOCOMOTIVE ENGINEERING is written by practical men for practical men, and the bound up form is a convenient and sure way of keeping a complete file for the year. We can only say that in this, as in other matters

where prompt action is desirable, come early and avoid the rush.

### Train for Cuban Business.

Chicago has a train de luxe, devoted exclusively to Cuban business, this winter. Cuba, as a winter resort, is vying with California, and the demand for better service for Chicagoans and the adjacent territory has reached such proportions that already there is assurance that the train is a great success. The service started last January and is weekly. The Chicago & Alton and Mobile & Ohio railways run a solid train, leaving Chicago every Friday afternoon at 2 o'clock and arriving at Mobile, Ala., Saturday afternoon. The new steamer, "Prince George," of the Munson Line, sails two hours after the arrival of the train, arriving in Havana harbor at daybreak Monday morning.

The Union Pacific passenger department have recently issued a portrait, and it is a good one. It is called "the oldest inhabitant," and although there is plenty of hair on the face, it is not white and snowy like that of Father Christmas. The portrait is not that of an old man but of a vigorous specimen of the Buffalo—the famous *Bos Americanus*—the Lord of the Land. "Formerly," says the circular, which goes with the picture, "the race across the western portion of the continent was by horse and caravan." Not that we ever heard of a caravan exactly racing, but the U. P. intends to point out that if horse, caravan, or even the oldest inhabitant thought of entering for a race with the Overland Limited, they would all and singly have the pleasure of being "left at the post." This, however, is beside the mark. The train crosses the western part of the continent in two nights from the Missouri river, and in three from Chicago, and the Union Pacific stand ready to let you have a portrait of the oldest inhabitant to hang on your wall and to whet your desire for a trip to the Golden West. Try them and see.

A Practically  
 Perfect  
 Portable  
 Pneumato

## PUNCH

Stop moving your heavy work  
 to the machine. One Man  
 brings this tool to the work  
 and punches it besides.

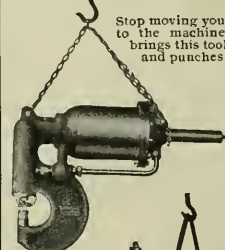

SAVES  
 TIME  
 LABOR  
 SPACE

Leading concerns in  
 all parts of  
 the country  
 use this  
 Punch.

Punch Size 3

Built in 5  
 Standard  
 Sizes.

Special  
 machines  
 built to  
 order.  
 Write for  
 Catalogue  
 C.

F. F. SLOCOMB & CO., Builders  
 WILMINGTON, DEL.

### CONTENTS.

	PAGE.
Air Brake Department.....	75
Baldwin's, A Glance at, Jas. Kennedy.....	63
Book Notices .....	69
Editorials:	
Cash for Accident Prevention.....	66
Boiler Temperature, Favors Uniform.....	66
Machine Screws, Standard.....	68
Steamship "Carmania" .....	68
Wages, Increase of.....	68
Quid pro Quo.....	69
Foremen, Different kinds of.....	81
General Correspondence .....	59
Locomotives:	
Danville & Western 2-8-0.....	55
Staten Island Rapid Transit, Notes on.....	69
Passenger 4-6-4 for the Monon.....	79
Motor Carriage, English A. F. Sinclair.....	62
Our Correspondence School.....	71
Personals .....	83
Private Car Lines, Defense of.....	94
St. Clair Tunnel, Electrification of.....	74
Savage Safety Brake.....	86
Shop Appliances:	
Fluesheet Cutter, Rapid.....	64
Short Stop on Electric Motor.....	70
Hydraulic Press, Portable.....	93
Shop Tools:	
Wheel Lathe, Niles 90-inch.....	85
Bolt Driver .....	79
Lathe, Attachment for Boring.....	89
Thread Rolling Machine, Rotary.....	91
Tough Ties and Living Fence Posts.....	81
Train Stopping, Automatic.....	53
Valve Motion, Joy's.....	55

# Railway and Locomotive Engineering

Copyright by Angus Sinclair Co.—1906

A Practical Journal of Railway Motive Power and Rolling Stock

Vol XIX.

136 Liberty Street, New York, March, 1906

No. 3

## Fighting the Avalanche.

The word "avalanche" is derived from the Latin *ad*, meaning toward, and *valis*, a valley. The word signifies the rush of snow or ice, earth or rock, from the

miliar with mountainous countries speak of avalanches as of three kinds. They are first the powdery, then those composed of ice and stones, and lastly the snow or *névé* avalanches.

snowfall fills up the smaller valleys and ravines high up the mountain and spreads itself like a mantle over the broad slopes and reaches far below the summer snow line. The



SNOW SHED, WITH SPLIT FENCE ABOVE, IN THE SELKIRK MOUNTAINS, ON THE CANADIAN PACIFIC RAILWAY.

mountain side to the valley below. The expression "snow slide" is, however, used to designate that kind of avalanche which takes place more often than any other, and, as its name implies, it is principally composed of masses of snow in which are often embedded fragments of trees and other débris. Those fa-

The most frequent and the most destructive form of avalanche is the snow slide. This is nothing less than the rapid descent of tons upon tons of wet, compact snow, which carries with it trees and bushes as it sweeps down. The theory of the cause of such slides is that during the winter the heavy

snowfall in the higher altitudes is heavier than that below. The snow fields of the lower and flatter areas help to support the masses which rest on the heights above. In the spring, when the sun's rays begin to attack the drifts, the lower portions of the snow slopes are the first to melt.

At last, when the supporting sheet below has melted, the loftier accumulation loosens its hold and rolls and tumbles down the mountain side.

Among the many descriptions which we have read concerning the action of one of these moving destroyers, the statement of a railroad officer of varied

experience, and who himself has seen what he describes, is perhaps the best. Mr. Lacey R. Johnson, assistant superintendent of motive power of the Canadian Pacific Railway, who was for several years master mechanic in the Rocky Mountain regions of that road, when giving the writer the result of his observations, said:



MOUNT RUNDLE, AT BANFF, B. C.

you watch it, if it is tearing out a new track through the forest, trees bow themselves almost to the ground some distance ahead of the slide itself, and from the mere force of the moving air many of them snap off ten or fifteen feet from the ground. As this enormous mass of snow hurls itself down the side of the mountain it picks up these broken

lines which pass over the Rocky Mountains, is that the coast or Pacific slope is steeper than that of the eastern side. Speaking roughly, the profile of this highway in the northland resembles in a general way the sky line of Mount Rundle, at Banff, B. C., the steep and abrupt declivity approximating to the coast side of the mountains and the gentler slope to that which stretches away to the prairies. Many years ago the gradual ascent of the eastern slope of the prairie became the subject of discussion between the U. S. Government engineers and those of the Union Pacific Railroad. By agreement, this

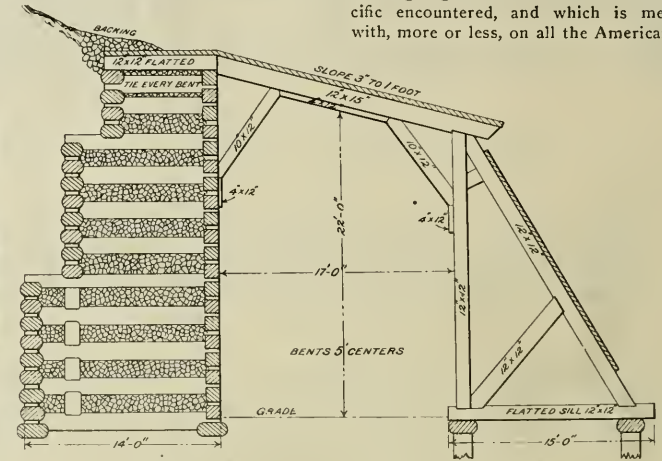

TYPICAL FORM OF SNOW SHED IN THE MOUNTAINS.

road was to receive \$16,000 a mile for the construction of the prairie section, and treble that amount for the mountain section. At length the construction engineers found themselves at Sherman, then the highest railway summit in the world, without having drawn any extra subsidy for mountain work. A controversy with the government engineers followed as to where the mountain section commenced, and a point in the vicinity of Cheyenne was finally

One of the peculiarities which the locating engineers of the Canadian Pacific encountered, and which is met with, more or less, on all the American

lines which pass over the Rocky Mountains, is that the coast or Pacific slope is steeper than that of the eastern side. Speaking roughly, the profile of this highway in the northland resembles in a general way the sky line of Mount Rundle, at Banff, B. C., the steep and abrupt declivity approximating to the coast side of the mountains and the gentler slope to that which stretches away to the prairies. Many years ago the gradual ascent of the eastern slope of the prairie became the subject of discussion between the U. S. Government engineers and those of the Union Pacific Railroad. By agreement, this

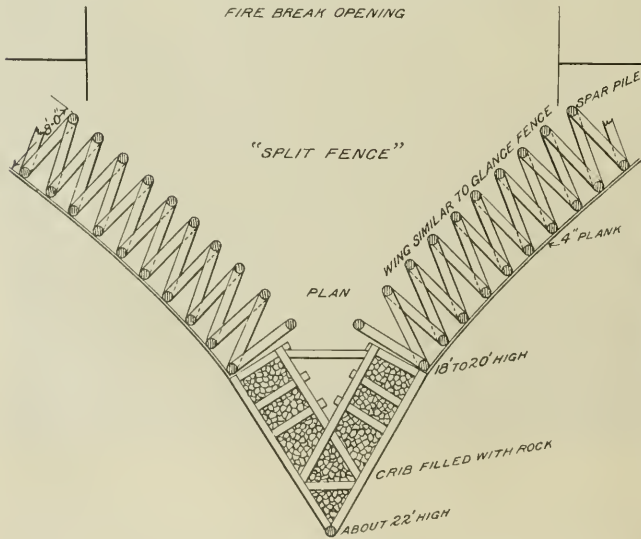

SPLIT FENCE PLACED IN THE TRACK OF A SLIDE.

from a gun or the steam from a locomotive, and as you watch you see it gradually gaining headway and speed as it dashes down the steep slopes, in-

trees and clears the slope entirely of roots, stumps and loose rock and sweeps them down into the valley below, and oftentimes it throws them



A BRITISH COLUMBIAN.

road was to receive \$16,000 a mile for the construction of the prairie section, and treble that amount for the mountain section. At length the construction engineers found themselves at Sherman, then the highest railway summit in the world, without having drawn any extra subsidy for mountain work. A controversy with the government engineers followed as to where the mountain section commenced, and a point in the vicinity of Cheyenne was finally



agreed upon as the place where the heavier grades began. There was not much difference in the character of the work while ascending the eastern slope, but it was decided that this point was

down over the roof of the shed rather than spread out and encumber the road beyond the ends of the structure. One of our illustrations shows a strongly built split

tracks outside, and upon these trains are run when the road is free from snow. This is done in order that travelers may enjoy an uninterrupted view of the grandeur of the mountain scenery.

Tyndall, in speaking of the mechanical energy consumed in the production of steam, water and ice, traces the cycle from the clash of the atoms of hydrogen and oxygen until the ultimate product is congealed in the form of snow. One of his similes is drawn from the stupendous forces of nature exhibited in the mountains by the fall of rock and ice from the crest of one of the lonely peaks. He tells us that the chemical union of the two gases in sufficient quantity to produce nine pounds of water is equivalent to the fall of a ton weight from a precipice 22,320 ft. high, and that the energy required to vaporize this quantity of water would be represented by a further fall of this heavy weight down a chasm 2,900 ft. deep, and, lastly, the heat energy liberated in turning the nine pounds of water into ice would be equivalent to the drop of one ton through a distance of 433 ft. Truly, the forces which act upon the infinitely little, far surpass in power and intensity those which man has learned to control.

In summing up the whole operation, and putting it in almost poetic language, Tyndall says: "I have seen the wild



TRANSCONTINENTAL PASSENGER TRAIN, WITH THE GREAT GLACIER OF THE SELKIRKS IN THE BACKGROUND.

the one where the prairie section ended and mountain construction legitimately began.

The C. P. R. snow sheds in the Selkirk range have been built along various parts of the road through the mountains and are placed in the regular track of the slides, because it has been found that when once a slide has cleared a track for itself it will almost invariably follow the same course year after year. These sheds are very strongly built, not to arrest the progress of a slide, but to carry it over the railroad into the valley beneath, and the angle of the shed roofs is made to conform as nearly as possible to the contour of the mountain side, or at least it offers no resistance to the movement of the snow. Massive cribwork is built on the side of the slope, and is made of 12 or 14 in. square cedar, with lateral braces bolted into the rock. The whole structure is filled in with broken stone to enable it to hold its ground. Triangular bents of the same timber are set up on the opposite side of the railroad track, and the whole is covered with a roof of 4-in. cedar planks. The average snowfall in the Selkirks is from about 35 to 45 ft. each winter.

Our illustrations show several of the forms used, and in some cases solid concrete is employed as a substitute for the rock filled cribwork. Glance cribs are sometimes built above the sheds, in order to deflect what may be called the frayed out edges of the slide and force the loose snow to pass

fence which is planted squarely in the track of a snow slide for the purpose of dividing the moving mass and throwing it toward the two sections of a shed



SNOW SHED, WITH SUMMER TRACK OUTSIDE, SHOWING PATH OF SNOW SLIDE WHERE TREES HAVE BEEN SWEEP AWAY.

which has been constructed with open spaces at intervals for the purpose of fire protection. Many of the sheds are built with what are called summer

stone avalanches of the Alps, which smoke and thunder down the declivities with a vehemence almost sufficient to stun the observer. I have also seen

snowflakes descending so softly as not to hurt the fragile spangles of which they were composed; yet to produce from aqueous vapor a quantity which a child might carry of that tender material demands an exertion of energy competent to gather up the shattered blocks of the largest stone avalanche I have ever seen and pitch them to twice the height from which they fell."

In the practical business of keeping a mountain railway open, a slide where it falls directly on the track is sure to constitute a very formidable blockade, as it piles deep on the shelf cut out for the road itself. Against these slides the rotary plow is called into requisition. When used amid snow slides, which, as a rule, are composed of very

such an open high road for the wheels of commerce that not even the avalanche itself can permanently block the way.

**The Compass and the Gyroscope.**

The mariner's compass has held its own for a long time, but, in common with other things terrestrial, its utility is being threatened by the gyroscope, another mechanical wonder evolved from the inventive spirit of the age. As is well known, the compass is an instrument used to show the magnetic meridian, or the position of objects with reference to it. It consists of a magnetized bar of steel and, fitted to its center, a cap which is supported on a pivot upright and sharp at the point to

age pointing to some half-forgotten landmark. Besides this, instead of being true, the needle is very easily disturbed. A small bit of magnetic iron will draw it with much greater force than the earth's magnetism. In iron



SIDE VIEW OF ROTARY SNOW PLOW.

wet snow, the rotary, if unduly forced, will act simply as a large polishing machine, smoothing off the face of the snow and making it like ice, but without clearing it away. In order to handle a huge snow slide with a rotary plow, it is necessary to employ a large gang of men to chop or pick the snow out in pieces and throw it down in front of the plow, in order that the rotating blades may fling it clear of the railroad track. It often occurs in what is called a very wet slide, one which has come down a long slope or from some high altitude, the snow gets packed so hard that it is necessary to drill holes in the mass and blast the snow out, and then break it up into pieces which the rotary can handle.

This blockade fighting on a railway is always exhilarating work, performed often under most trying and disheartening conditions, and always under the pressure of time. In thus penetrating into the mountain strongholds of nature and in braving the eternal snows, the railroad has, in building up its defense works, interposed, as it were, the strong shoulder of Atlas to bear up the colossal burden, and has thereby guaranteed

lessen the friction, and on which the needle may move with the slightest magnetic attraction. It is carefully protected in a box and suspended in a horizontal position not subject to the roll of the ship. The needle is very un-

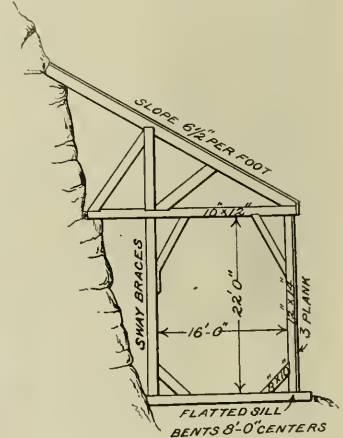

SNOW SHED ON A STEEP INCLINE.

ships, in addition to the well-known deviations of the compass with place and time, it has become quite erratic. It is one of the very few instruments of great value that has not improved with age. It is the same to-day as it was among the mariners in the Mediterranean in the twelfth century.

The gyroscope consists of a heavy rimmed wheel mounted in gimbals and rotating by means of an electric motor. At a speed of three thousand revolutions a minute it has been demonstrated that the wheel will maintain itself constantly in one direction, the sudden turning of the body upon which the movable gimbals are sus-

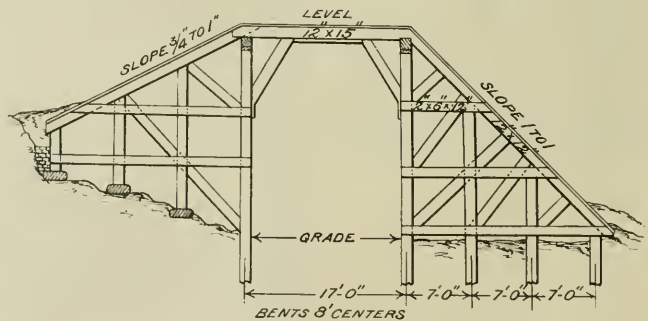

SNOW SHED IN BOTTOM OF VALLEY. SLIDES FROM BOTH SIDES MAKE IT PRACTICALLY A TUNNEL.

steady. Although credited with being true to the pole and loyal to the north, this is not by any means the case. It tremulously aims somewhere about the north, like the palsied finger of decrepit

pendent not affecting the fixed plane of the wheel's unchanging motion. The German naval authorities have been experimenting with the gyroscope on one of their warships. The wheel was set

in motion and the ship described a large number of sudden curves, and big guns

suddenly arrested, the heat developed by the sudden stoppage would be sufficient not only to fuse, but to vaporize the entire material of which the earth is composed.

The fact that arrested motion turns at once into heat has been made use of in the science of gunnery. The Palliser shell is a cast iron projectile with its point chilled like the tread of a car wheel. It is usually employed against armored ships of war or forts. This cast iron shell is filled with a powerful explosive in the usual way, but is not fitted with a fuse of any kind. When fired squarely against the steel plates of a heavy battleship, the

F. higher than that of the air outside. The reason for this state of affairs is said to be the radiation of heat developed in the electric motors as the trains are accelerated when leaving stations, and to the heat produced by the stopping of the trains by which the moving energy of the cars is transformed into heat.

These two causes probably account for the temperature rise, but it must be remembered that they are both prominent features in the excellence of the service which the company renders to the public. It is probable that by next summer the problem of ventilation on which the Interborough Company is working, will be so far solved that while the good service features will be maintained the heated air due to the acceleration of the motors and that produced by powerful brake action, will be driven out of the subway by mechanical



FALLS OF THE BOW RIVER—BANFF, B. C.

were discharged to ascertain the effect of concussion and vibration. The greatest shocks and most rapid movements that could occur on a ship had no effect whatever on the apparatus, the wheel maintaining its original position with perfect accuracy. The gyroscope has no magnetic quality of its own, and is not in any way affected by magnetic currents. By careful adjustment the wheel can be set going pointing to the north or any other desired point, and by retaining this perfect plane the true points of the compass can be readily ascertained at any place or time. A comparison of the gyroscope with the amplitude compass has shown that it is possible by means of the gyroscope to discover errors in the compass. The experiments, which are being continued, will probably result in the general use of the gyroscope in conjunction with the compass, the gyroscope correcting the errors of the compass from time to time.

**Train Stopping and Heat.**

Astronomers tell us that this earth is moving in an enormous ellipse around the sun and that it makes an average speed of over a mile a minute in travers-

kind. When fired squarely against the steel plates of a heavy battleship, the



THE "THREE SISTERS," AT CANMORE, ALB.

motion of the shell is arrested in so short a space that the heat developed is sufficient to ignite the bursting charge, and so shatter the shell with the infliction of more or less damage to the ship.

Nearly everyone knows that the stoppage of a railway train develops heat and the sparking of the brake shoes on a retarded train as it comes into a station is an evidence of the fact. Still further evidence of this well-known fact was afforded by some investigations concerning the temperature of the New York Subway. On the hottest days last August the tunnel was found to be about 10°

means, and that the trains will run through an atmosphere probably several degrees lower than that above ground.

The Chicago Pneumatic Tool Company have been awarded the gold medal at Liege for the excellence of their tools and appliances, and have also received the silver medal for their Franklin air compressors. This company have received many such evidences of appreciation since they made their first display at the Cotton States Exposition at Atlanta, Ga., in 1895.

Work has been begun on the railway designed to facilitate the ascent of Mont Blanc. The work is expected to be finished in five or six years, and will reach an altitude of 10,410 ft. The total length of the railway will be 12 miles.

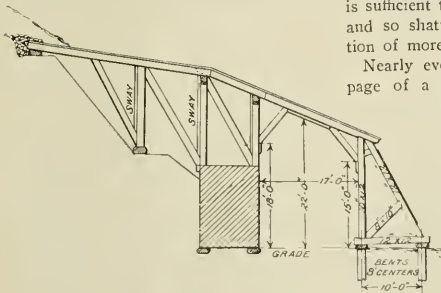

SNOW SHED ON COMPARATIVELY FLAT INCLINE.

ing this orbit. It has been estimated that if this motion of the earth were

daily average temperature of the tunnel was found to be about 10°

### Patent Office Department.

#### PACKING RING.

A patent has been granted to Mr. Stephen Schultz, Schenectady, for a packing ring for pistons and similar devices. As shown in the accompanying illustration, the walls of the ring are separated along the greater part of the circumference, leaving a small part of the body solid, the separated portions

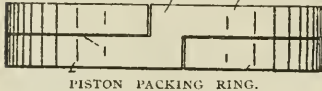

PISTON PACKING RING.

being superimposed throughout their length and lying in the same vertical plane, their ends terminating in proximity to the full width portion. The resilience of the ring gives outward pressure to this clever device.

#### IMPROVED COMPOUND ENGINE.

An improved compound engine has been invented and patented by Mr. Carl V. Frisk, Chicago, Ill. The valve seat is furnished with openings leading into the opposite ends of both high and low pressure cylinders, with an intercepting valve between the slide valve and high pressure cylinders for cutting off the steam supply to the high pressure cylinder and directing it to the low pressure cylinder. The entire valve apparatus for both cylinders is moved by a single rod attached to a valve yoke in the usual manner.

#### IMPROVED BOILER.

A patent has been granted to Mr. Louis Marchessault, of Minneapolis, Minn., for an improvement in boilers. As will be seen by the accompanying illustration, the devices consist of a bulging

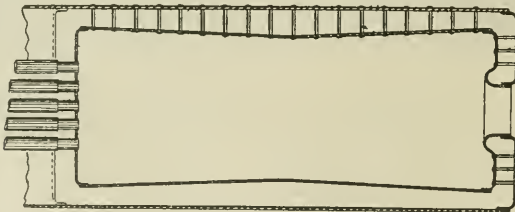

IMPROVED BOILER.

inwards of the side sheets of the fire box, giving a larger water space where the heat is the greatest. In addition to this change the ends of the flues attached to the flue sheet of the fire box are reduced in size, permitting an increased water space adjacent to the flue sheet, and also leaving a larger area of metal in the flue sheet between the flues. The improvements may be applied to any kind of boiler.

#### SMOKESTACK.

Mr. Paul Dickinson, Chicago, Ill., has patented a smokestack suitable for en-

gine houses where the smokestack may extend across the path of a traveling crane, a stop for the crane and means connected with the smokestack and stop to move the stop into its operative position when the smokestack is extended across the path of the crane, and to remove the stop from said position when the smokestack is raised out of the path of the crane.

#### RETURNING WASTE WATER FOR LOCOMOTIVES.

Mr. Francis O. Whealon, St. Paul, Minn., has patented an apparatus consisting of a series of pipes with check valves attached forming a fixed return passageway between the overflow outlet of the injector and the waterfeed tank. The apparatus is readily adjustable to any injector, and, besides its water saving quality, it has the added advantage of partially heating the water in the tank.

#### LOCOMOTIVE BOILER.

An improved locomotive boiler has been patented by Mr. John A. Welton, Canal Dover, Ohio, consisting of a main shell, a secondary shell connected therewith, and a fire box corrugated throughout its entire extent, and secured to the tube sheet in the usual manner. The corrugations lessen the strain incident to expansion and contraction, and increase the area of the heating surface.

#### CAR AXLE BOX LID.

Mr. Albert G. Elvin, Franklin, Pa., has been granted a patent for a self-closing axle box lid. The device has a central cylindrical bore, a squared stem projecting from one of its ends and a cam face composed of alternated inclined and flat surfaces on its opposite end. A spiral spring interposed on the

pivot pin forming the hinge of the lid acting on the inclined faces of the cam securely closes the lid.

#### CAR REPLACER.

Mr. Henry Pratt, Kenilworth, Ill., has secured a patent for a car replacer with a flat bottom tapering in thickness toward one end having inwardly curved, upwardly directed side flanges adapted to direct a car wheel centrally of the plate, and a central groove adapted to engage the top of the rail and prevent displacement, the bottom end being broad and projecting a considerable dis-

tance on either side of the rail. The replacer is furnished with a plurality of transverse claws on the under side to prevent longitudinal displacement.

#### DEVICE FOR CLEANING FLUES.

A patent has been granted to Mr. Henry E. Parson, New York, N. Y., for a device for cleaning flues. It consists of a combination of a steam nozzle, having a valve seat in advance of the steam inlet, a separate air tube inlet mounted in rear of the steam nozzle, and a series of radial wings beveled on their forward edges adapted to locate the nozzle axially on the mouth of the flue.

#### VALVE ROD AND WRIST PIN CONNECTION.

An improved valve rod and wrist pin connection has been patented by Mr. Anton Skofsrud, Chicago, Ill. The device embraces a threaded rod and an internally threaded sleeve, as shown in the illustration. The sleeve engages with the rod with opposite handed threads to



VALVE ROD CONNECTION.

those of the rod. A locking nut holds the rod and sleeve in place, the rod having a flat end bearing on suitable bushings adapted to form the bearing for a wrist pin.

#### MECHANICAL STOKER.

A mechanical stoker has been invented and patented by Mr. Morris B. Brewster, Columbus, Ohio, providing mechanism for conveying fuel to a hopper outside and above the fire box door, where it is conveyed at intervals to a distributing device within the fire box, the fuel falling on a receiving table within the fire box and meeting with adjustable fluid pressure jets adapted to throw the fuel to all or any particular part of the fire box. The device has been successfully operated at Columbus, Ohio.

It is doubtful if any important improvement in engine valves and valve mechanism has been effected in the last twenty years. This has not been due to any apathy on the part of inventors. Many so called improvements on valves and valve mechanism have been patented and many of them have been thoroughly tested, but the verdict of steam users has been that the older devices were more satisfactory than the new ones. After two centuries of human effort, the valve gear of steam engines has been perfected so far as combining efficiency as a gate for admitting and exhausting steam can be combined with simplicity of mechanism.

**Frisco Ten-Wheeler.**

The engine which forms the subject of our illustration is a simple 4-6-0 machine, built for the Kansas City, Ft. Scott & Memphis Railroad, which is part of the Frisco System, and this latter is the designation which appears under the cab window. It was built in the Schenectady shops of the American Locomotive Company.

The cylinders are 21x28 ins., with piston valves actuated by direct motion. The driving wheels are 63 ins. in diameter, and with boiler pressure of 190 lbs., the calculated tractive effort is about 31,650 lbs. The weight of the whole engine in working order is 184,000 lbs., and that carried on the drivers is 138,000 lbs. The ratio, therefore, of tractive power to adhesive weight is as 1 is to 4.36. The main drivers are without flanges. The driving wheel base is 14 ft. 10 ins., while that including the truck measures 25 ft. 9 ins. The rods are all of the I-section, the side rods having solid ends.

The boiler is 70¾ ins. diameter at the smoke box end, and the style is that of the extension wagon top type. The taper

ring and becomes 5½ at the throat. The back water space at the lowest point is 4 ins. with slight taper toward the top. The heating surface is in all 2,954 sq. ft. An idea of the heating surface may be had by looking at the pit of a turn table, about 61 ft. 4 ins. long. The area of the circle swept out by a table of this size is approximately equal to the heating surface of Frisco engine No. 731. The fire box contributes 175.7 sq. ft., and the tubes make up the rest. These tubes are 14 ft. 8 ins. long, and there are 364 of them, each 2 ins. in diameter, measured outside. The grate area is 47.69 sq. ft.

The tender is of the ordinary shape with steel frame and heavy arch bar trucks. The tank, with its water bottom, has a capacity of 6,000 U. S. gallons, and carries 12 tons of coal. The weight of engine and tender in working order is 311,000 lbs., and the wheel base of both together is 54 ft. 9½ ins. A few of the principal dimensions are as follows:

Heating Surface—Tubes, 2,778.4 sq. ft.; fire box, 175.7 sq. ft.; total, 2,954.1 sq. ft.

Axes—Driving journals, main, 9x12 ins.; others, 9x12 ins.; engine truck journals, diameter,

**British Notes and News.**

BY A. F. SINCLAIR.

The Great Western Compounds, needless to say the three de Glehn compounds on the Great Western Railway of England, are receiving a great deal of attention, and everything of interest in their working which is made public receives considerable notice and comment. The following are the principal dimensions of Nos. 102 and 103, the third engine being an exact copy of the latter; while the wheels are according to the Atlantic type:

	No. 102.	No. 103.
Dia. of cyl., 2 low press.....	13¾ in.	14¾ in.
" " " 2 low press.....	22½ "	23½ "
Stroke of cyl.....	25 in.	25 in.
Dia. of drivers.....	6 ft. 8½ in.	6 ft. 8½ in.
" " rear wheels.....	4 " 7½ "	4 " 7½ "
" " truck wheels.....	2 " 12½ "	3 " 2 "
" " boiler.....	4 " 9½ "	4 " 11½ "
Length of boiler.....	13 " 7½ "	14 " 13½ "
Htg surface: tubes.....	2888.7 sq. ft.	2882.7 sq. ft.
fire box.....	167 "	173 "
Total.....	2855.7 sq. ft.	2755.7 sq. ft.
Grate area.....	29.5 sq. ft.	33.3 sq. ft.
Total weight (full).....	64½ tons.	71½ tons.
Boiler pressure.....	227 lbs.	227 lbs.

The arrangement of parts is on the usual de Glehn plan, the high pressure



TEN WHEEL ENGINE FOR THE FRISCO.

W. A. Nettleton, General Superintendent of Motive Power.

American Locomotive Company, Builders.

of the gusset sheet amounts to 5¾ ins. The crown sheet slopes up toward the front 3 ins., and the steam and water space above it has an average depth of about 23½ ins. The crown is arched, being bent to a curve with 72 in. radius. The side and crown are made of one sheet and the staying is radial, and strong gusset braces tie the back and roof sheets together. The fire box side sheets slope slightly inward so that the water space which is 4 ins. at the mud ring widens to 6¾ ins. at the top. The front water space is 4½ ins. at the mud

6 ins.; length, 11 ins.; tender truck journals, diameter, 5½ ins.; length, 10 ins.

Fire Box—type, wide; length, 102¾ ins.; width, 67¾ ins.; thickness of crown, ¾ in.; tube, ½ in.; sides, ¾ in.; back, ¾ in.

Brake—New York; pump, Duplex No. 2; one air reservoir, 24½x14 ins.

Piston—rod diam., 4 ins.

Tender Frame—10-in. channels and plates.

Valves—Type, Piston; travel, 5¼ ins.; steam lap, 1 in.; ex. lap line and line.

Setting—Line and line full gear, ¼ in. lead at ¼ stroke cut-off.

Wheels—Engine truck, diam., 30 ins.; kind, C. I. Spoke Center; tender, truck, diam., 33 ins.; kind, C. I. plate center.

cylinders being outside driving the rear pair of the four coupled wheels, while the low pressure cylinders inside drive the leading pair of the four. Walschaert valve gear is used for both sets. The route on which these engines are employed is from London to Plymouth, a distance of 245 miles, and the journey is done by the express trains without a stop in 267 minutes. The road is a fairly level one five-sixths of the way, but a distance of about 40 miles is somewhat difficult with one grade as steep as 132 ft. to the mile (1 in 40), while

a number of others are only a little less difficult, one stretch of over a mile being 1 in 42. In addition to these grades there are some nasty curves which preclude the highest speed at a number of places and several large towns having also to be traversed (not of course on the level) through which slow speeds have to be maintained, it follows that the average suffers considerably.

The loads hauled are, however, light, the average being under 200 tons, but that notwithstanding the speeds of over 80 miles an hour, which have to be made some parts of the way to keep to the schedule, constitute very fine running. But it has yet to be proved that the work is better or cheaper done with the compounds that is possible with the simple engine. Indeed, in some records of running published the performances of a simple Atlantic type engine and the de Glehn No. 103 are compared not with any advantage to the latter. The simple engine has the same size of driving wheels and the same steam pressure as the compound, but the heating surface is 600 sq. ft. less and the fire box is 6 sq. ft. smaller. The cylinders are 18-in. bore and 30-in. stroke. This engine with an equal load did a better performance than the best of the compounds published, being at no part of the journey behind time, and reaching Paddington, London, nearly five minutes ahead of time. The highest speed attained—77½ miles an hour—was not so fast as that of the compound, but the slowest speed of the latter fell to 17 miles an hour, while the simple engine never got below 19 miles an hour. The question is, of course, not one of speed, but of economy. Still it may be suggested that compounding, with all the complication involved, is instituted for the purpose of producing a certain amount of work with less steam, and if it can be shown that a simple engine, with a smaller fire box and less heating surface, is capable of doing equally good work, it means either that the complication referred to is unnecessary or that the London-Plymouth express service is not a suitable test for the compounds.

#### ELECTRIC LIGHTING OF TRAINS.

A British publication devotes an article to consideration of this subject, and advances the opinion that in the not distant future the Government will make the use of electric lighting compulsory on all trains in the United Kingdom. The writer may be a little too sanguine, but all travelers will fervently pray for an early realization of the proposal. Long distance trains are fairly well illuminated, mostly by gas, although electricity is coming into use to some extent. But local trains, the

stop-at-all-the-farms variety, are miserably lit and anyone condemned to ride in one of them for an hour or two has a pretty uncomfortable time. The writer in question advocates the use of this form of light on three principal grounds: improved lighting, less cost, and the absence of danger.

#### LOCOMOTIVE BUILDING IN SCOTLAND.

The North British Locomotive Co., Ltd., a combination of three leading locomotive building firms, are the most productive concern in the business in Britain and it is very probable that their trade record for 1905 may be taken as typical of others in this country. The year began with only a limited amount of work in hand, and as orders in the early months were few and unimportant, trade looked rather gloomy. Matters improved, however. Good orders from South America—500 engines—and from Japan—200 engines—helped things, and as India and Egypt kept well up to the average the total output was somewhat in excess of that for 1904. Prices were, however, as the result of the slackness early in the year, and increasing foreign competition, much more keenly cut than in the preceding year, and it is doubtful whether, the increased output notwithstanding, there will be a greater surplus for appropriation among the shareholders. A curious feature of the output was the ever diminishing proportion for home railways. The total number of engines ordered for employment on lines in the United Kingdom did not exceed 70, of which 47 were for one road, the Great Central Railway Company of England.

#### THE REASON.

The decrease in orders for home railways is certainly due to some extent to the tendency on the part of locomotive superintendents to go in for the construction of their own engines. It has been suggested that this is due to a desire on the part of the superintendents to magnify their office, but it appears to me probable that the reason is to be found in quite another direction. There can be no doubt that the company whose sole business it is to design and build locomotives are in a better position to do so economically than the haulage department of a railway company, and there must be a reason much more convincing than mere personal egotism or a desire for aggrandizement and by inference profit—on the part of the officials to account for the fact that one railway company after another have begun to manufacture their own engines. It occurs to me that the reason may be found in a want of enterprise on the part of the locomotive building companies in Great

Britain. It is certainly a curious fact that most of the experiments in compounding have had to be borne by the railway companies, that the most successful simple engines have been designed by locomotive superintendents, and that on the other hand the most successful compounds so far operated in Britain—the de Glehn engines on the Great Western of England—have been constructed after much costly experiment by a French firm at their own expense. None of the British firms appear to undertake such experimental work except when it is done to a locomotive superintendent's designs, who would of course be responsible for its success or failure, or to their own designs submitted to the purchaser for his approval, who is then shouldered with all risk. Whether this be the true reason or not no unprejudiced observer can fail to be convinced that the ever increasing tendency of railway superintendents to build their own engines is not as suggested from any love of the work or because it is more economical, but because they are driven to it by the failure of the manufacturing companies to meet their requirements.

#### HOME MADE LOCOMOTIVES.

Reference is made above to the fact that many British railway companies construct their own locomotives—build them at home as it were—and it is now said that the Great Central Railway Company are about to adopt the same course. The Great Central are the largest company among those who have hitherto provided their power entirely by purchase, and should the rumor prove to be well founded it will be still another blow to the manufacturers. In this connection a director of one of the manufacturing firms has written a letter of protest to the *Times*, in which he virtually charges locomotive superintendents with under-estimating the percentage of ineffective expenditure or dead charges. He contends that on railway works it is the practice to add only 20 or 30 per cent. to the cost of labor instead of adding from 80 to 100 per cent., by which means the apparent cost of manufacture is considerably less than the actual. The writer of the letter further contends that railway companies are compelled to maintain a staff and plant in excess of their real requirements, because equal to the maximum. But the companies can claim compensating circumstances in being independent of trade fluctuation, and in having the reasonable probability of having their engines ready when they need them. It is difficult to forget the condition of things after a big engineering strike a few years ago, when the delivery of locomotives could not be guaranteed under eighteen months.

# General Correspondence.

## Driving Tires on a Boring Mill.

Editor:

The accompanying photograph, from which you can make an illustration, was taken in the Northern Pacific machine shop at South Tacoma, Wash., and shows the way driver tires are bored on the Niles boring mill. There are three jaws used on tires up to 56 ins. diameter; over that size, four jaws are necessary. They are made of cast iron, 12 ins. long by 4 ins. wide, and are held in place by two 1 in. bolts. The clamps are made of  $1\frac{3}{8} \times \frac{3}{4}$  in. steel, slightly enlarged where the set screw goes through. The set screws are  $\frac{3}{4}$  in. tool steel, cupped on the point. This arrangement has been found to be very convenient in comparison with the bolts, clamps and blocks formerly used. The hooks suspended from air hoist and shown in foreground of picture, are very useful for lifting cylinder heads and can be reversed for lifting front ends.

H. F. DANIELS.

South Tacoma, Wash.

## Grease as a Lubricant.

Editor:

At the last convention of the Traveling Engineers' Association, held in Detroit, Grease as a Lubricant was one of the principal topics of discussion, and from the information given, and from the results of tests made in road service, it was decided that grease as a lubricant on any but driving box journals, main and connecting rod pins, is not an economical or a safe practice. The consensus of opinion was that owing to its higher viscosity a plastic grease was unsuitable for any other bearings. Many admitted that they had tried it in trailer journals, engine and tender trucks, but with little or no success. In most cases, complete failure was the result.

Various reasons were assigned for these apparent failures on the part of the grease, such as high journal speed, improper filling of bearings, wrong kinds of bearing metals, etc. All these apparent defects were remedied, but with the same result—an engine failure due to hot bearing. A few instances were mentioned where grease was run in trailer boxes with some success, but apparently with not as much confidence as if packed in the good old fashioned way, with wool waste and engine oil.

The writer made the assertion at the convention that the failures to obtain good results from grease on engine truck, trailer and tender truck journals was not due to any of the above men-

tioned causes, i. e., high speed, poor fits, etc., but to mechanical reasons and to the nature of the grease itself.

Lubrication consists of the interposition between two bearings of any substance that will tend to prevent friction by keeping the bearing surfaces from coming in direct contact with one another. No bearings are absolutely perfect, but if viewed under a magnifying glass, will show minute scratches, little hills and hollows, etc. Oil being a viscous fluid, has a tendency to adhere

friction of the two metals coming in direct contact with one another will cause the oil near that particular point to volatilize and thus forming other dry spots, we soon have the oil volatilized over the entire bearing surface and a hot journal as the result.

Grease being a plastic instead of a fluid lubricant will not find its way between bearings unaided, but must be forced there. As it would be practically impossible to force grease between two perfectly fitting bearings on a locomo-

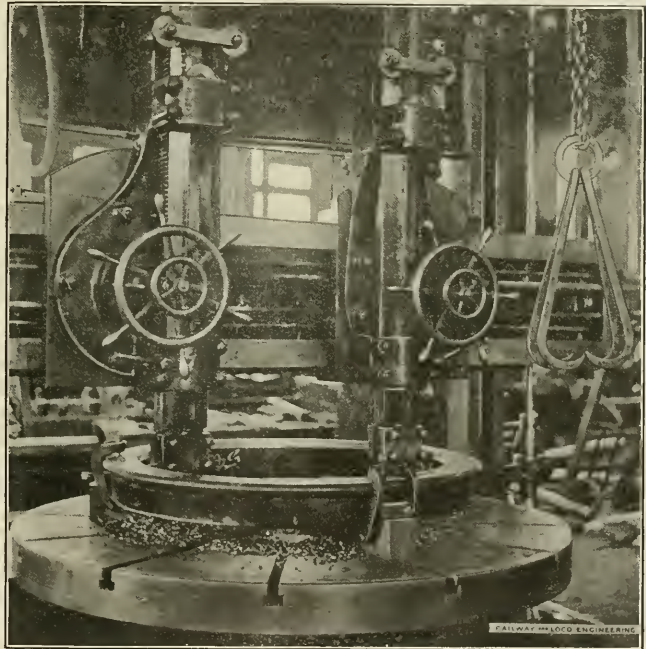

DRIVING TIRE ON A BORING MILL, SOUTH TACOMA SHOPS, N. P. RY.

to whatever it comes in contact with, and when placed on a bearing surface will fill up these small scratches and cavities, and in case it is a revolving bearing, it is carried between the two rubbing surfaces until it forms a film thick enough to hold the two bearings apart, thus in a great measure eliminating friction.

Oil will find its way through the slightest opening, and stand a pressure almost incomprehensible before its particles are eliminated entirely. If, however, but a single spot on a revolving journal becomes dry, the heat generated by the

tive without entailing too much loss, these openings must be provided for. This is done in the case of driving journals and crank pins by the power exerted on the piston when working steam, and by the counterbalances, friction and piston resistance when drifting.

Looking at the diagrams, Fig. 1 shows a locomotive driving wheel in forward motion, with crank pin on the upper back eighth. In this position the pressure of the steam against the piston and back cylinder head has a tendency to force the driving journal against the front side of the brass, or the front part

of the brass against the journal which ever way you desire to call it, leaving the opening as shown by arrow at *a*, for the introduction of grease. This opening may be infinitesimally small, but, nevertheless, it is there.

We might call attention in passing to the stress placed on the fitting of the driving box brasses by the Traveling Engineers' Committee, viz., "The clearance of the brasses on each side is very important. The brass should be cut back not less than  $\frac{3}{4}$  in. from the bottom of the bearing, and should have no rough edges. This is to prevent the scraping off of the lubricant," etc. Again, in the discussion, "The brass should have a good crown bearing" \* \* "driving brasses which proved satisfactory with grease as a lubricant had no groove in the crown of the brass," etc. How different this method of fitting a brass from the old way, when cellars are packed with waste, and oil used for a lubricant.

When oil is used brasses are usually made a neat fit at the sides and "eased

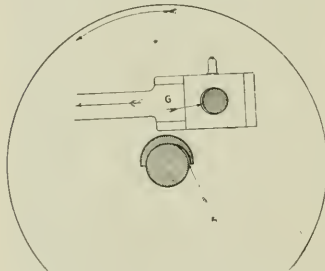

FIG. 1. DRIVING WHEEL WITH PIN ON TOP EIGHTH, MOVING FORWARD.

off" in the crown. Yet as the committee reports, the fitting of the brass is all important with grease lubrication, as, with a plastic grease, the attraction of cohesion is greater than the attraction of adhesion, and, consequently, each particle of grease that finds lodgement on the sharp edge of a brass, simply acts as a scraper picking up other particles that may be adhering to the journal, and were it not for the forward and back movement of the driving journal in its housing, little or no grease would find its way between the two bearing surfaces. Referring again to Fig. 1, note the pull on the main rod leaves an opening between the front side of the crank pin and the brass—a place for our grease, as shown by the arrow marked *b*.

Fig. 2 shows the same wheel, still in forward motion, but with pin near the bottom quarter. You will note the openings have now changed, owing to change in direction of applied power, and the opening in the driving journal is at the front of the box, while that in

the main rod brass is at the back, *c* and *d*, thus allowing the film of grease to complete its revolution.

Turning now to Fig. 3, representing an ordinary arch bar tender truck. It will be seen that the force which im-

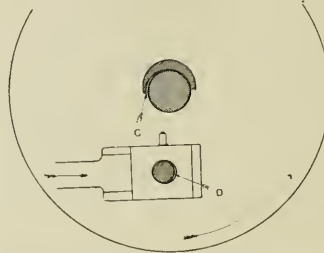

FIG. 2. WHEEL MOVING FORWARD PIN BELOW AXLE.

pels the truck forward is imparted at the center bearing *E*, and from there communicated to the wheels through the center bearing, to the arch bars, thence to the truck boxes, to the brass, and, finally, by the brass to the journal, causing the wheel to revolve and carry the truck forward. Note now the action of this force on the bearing surfaces. It will readily be seen that so long as the motion is continued in one direction that the brass hugs the journal opposite the direction of rotation; therefore, the back edge of the brass always acts as a scraper, scraping the grease off the journal as fast as it is brought forward, the only opening between the brass and journal being at the front side, *g*, Fig. 3.

The law that applies to the tender truck holds good in engine trucks and trailers or any other bearing having its motion imparted to it by means of the journal on which it rests.

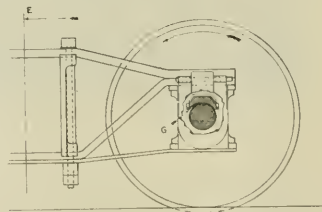

FIG. 3. ARCH BAR TRUCK SHOWING SPACE BETWEEN JOURNAL AND BRASS.

Therefore, if it is desired to use grease in engine trucks, trailers or tender trucks it will be necessary to apply a more limpid article than is used on driving journals or crank pins or else cut such oil ways into the brasses as will allow the grease to be carried up under it.

F. P. ROESCH.

Chicago Heights, Ill.

Piston Rod and Valve Stem Packing.

Editor:

The sketch illustrates a design of metallic packing that, because of its simplicity, small number of parts, small amount of labor and consequent small cost of applying should make it popular. It was designed by Mr. Whitney, a machinist on the C. R. I. & P. It has neither vibrating cup nor ground joints.

*A A* are two metallic rings inserted in the stuffing box. These may be made any width, to suit different depths of boxes. *B* is an end view of one of the rings, showing the manner of cutting them. *C* is a round steel wire spring about  $\frac{1}{8}$  in. in diameter. Its purpose is

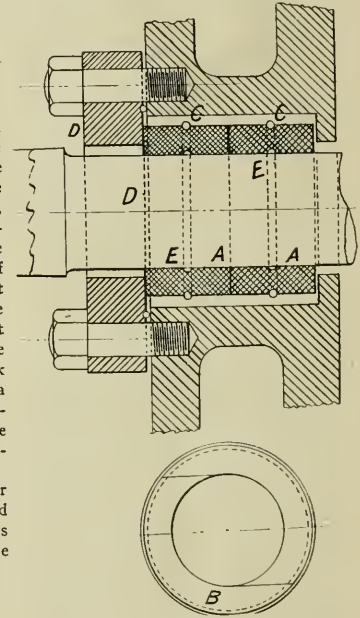

PISTON ROD AND VALVE STEAM PACKING.

to hold the ring to the piston rod while the engine is drifting. When the engine is working steam the rings are held to the rod by the pressure around the outside of them, in addition to the small pressure exerted by the springs.

The rings are also held against the plate *D*, which takes the place of the gland, by the pressure on the front end of front ring. *E* is a small groove cut around the inside of the ring. No machine work is necessary except boring out, if the rings have been properly moulded. A set of this packing was applied to a switching engine on the B. C. R. & N., on July 18, 1905, and has been in service continuously up to the present time (January 28, 1906), a greater part of the time both night and day, and the gland stud nuts have not once



been loosened. The packing is now perfectly tight. A patent has been applied for. This packing is to be tested on the C., R. I. & P. IRA A. MOORE.  
Cedar Rapids, Iowa.

**Lever Lock Grease Cup.**

Editor:

The necessity of a suitable lock for grease cups on locomotive rods has been a long felt want. This necessity has been met by Mr. A. F. Finch, road

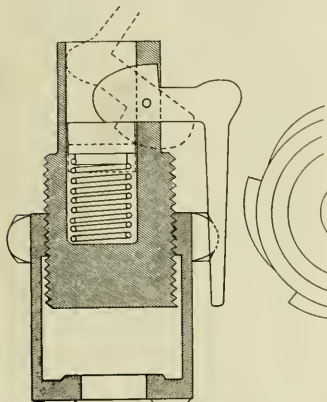

FINCH'S LEVER LOCK GREASE CUP.

foreman of engines on the Iowa division of the Chicago & Northwestern Railroad, as the accompanying drawing will show.

It can be readily seen that when necessary to force more grease on the pin it is only necessary to put a wrench on the top of the plug to turn it to the right. The plug can be left at any desired position. The trigger, as shown on the drawing, engages with the notches on a band shrunk on the grease cup. These notches are shouldered to the left and opened to the right, thus allowing the plug to turn to the right but not to the left, while the lever is in a locked position. When necessary to remove the plug for the purpose of refilling the cup, the lever is turned upward, as shown on the dotted line in the drawing, thus allowing the plug to be turned to the left and removed from the cup, and after filling, the plug can be again entered in the threads and the lever turned down. As can be readily seen, this entirely does away with the jam or lock nut. The device has been protected by a patent, and there is a growing demand for the lever lock cup. Chicago, Ill. A. B. SILL.

**On the Zambesi Express.**

Editor:

There is not much incident on the trip, though the life at wayside stations when the engine stops for a drink is always interesting. At Mochudo two tame

ostriches walked majestically up and down beside the train, their little heads on a level with the passengers, who sometimes would hand them a biscuit.

I was told to keep my camera out of sight, or they would gobble it up. A man was lighting a cigarette at one of the carriage windows when one of the ostriches bit from his hand and swallowed a box of matches. I understand they lit only on the box, so the probability of the lucifers igniting on any of the stray bits of bottles on the staircase going down was minimized. TRAVELER.

**L. & N. E. Connecting Rod.**

Editor:

I am enclosing you herewith blueprint of main rod on Lehigh & New England Railroad engines, Class 1034-E. You will note the back end arrangement and I would also call your attention particularly to the fact that the spacing block is applied from the side instead of the back, as is

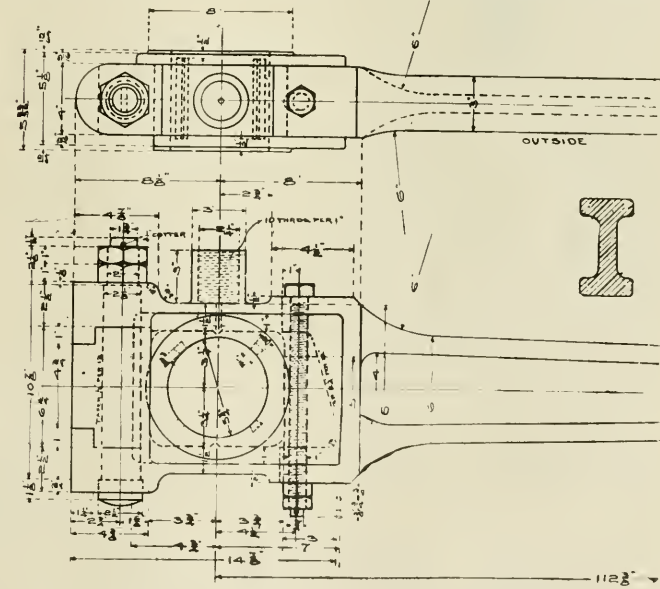

usual in this type of rod. We find this a very desirable arrangement inasmuch as part of the strain is on the forks instead of all coming on the bolt, as is the usual custom. This rod is also equipped with grease cup, details of which are not shown on the drawing. My observation is that this type of rod is very desirable, particularly when it is necessary for the engineman to disconnect the engine while out on the road, as it is much easier to get out one large bolt than several small ones used in the old style of strap. Usually railroad companies do not equip their engines with the proper facilities for getting this type of

rod apart, and when the old strap has three or four bolts, you very often find one or more of these tight, causing embarrassing delays in getting it apart, and my personal observation is that this is a very ideal arrangement which we have designed and put in use.

H. C. SHIELDS,  
Superintendent.

Pen Argyle, Pa.

The rights to build Parsons' marine turbines in the United States are held only by the Allis-Chalmers Company, of Milwaukee, Chicago, Cincinnati and Scranton; Wm. Cramp & Sons, Philadelphia; W. A. Fletcher Co., Hoboken, N. J.; The Quintard Iron Works, New York, and the Bath Iron Works, of Bath, Me. The Allis-Chalmers Company are not only licensees under the Parsons marine turbine patents, but they also hold the rights for manufacturing the Parsons turbine blowers and compressors, and have recently formed an alli-

ance with the Honorable Chas. A. Parsons, the eminent turbine inventor, for a full co-operation and interchange of data on steam turbines for land operations. They are at the present time practically doubling their immense plant at West Allis, Milwaukee, Wis., the greater part of the new shops being intended for an extension of their steam turbine work and the electric generators to be driven by the same. They will, at their West Allis works, build marine steam turbines for the great lakes and for the Pacific Coast, and both there and at their Scranton works will build marine turbines for the Atlantic trade.

Development of Valves and Valve Motion.\*

PART ONE.

BY ANGUS SINCLAIR.

We do not know of any subject that excites so much interest among the rank and file of mechanical men as valve motion. There is certainly no other subject which excites so much discussion, and no one which leaves the disputants so little edified after they

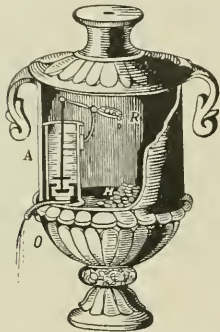

FIG. 1. LUSTRAL VASE.

have wrangled for hours about details of construction or design that cannot be settled by ordinary reasoning. There is a tendency among many people to assume that there is something about the mechanism that actuates the valves which is beyond the ordinary understanding, and that certain experts have a monopoly of the exact knowledge concerning valves and valve motion. This belief is not well founded. Any man of ordinary intelligence, who will devote careful attention to what functions a valve motion performs and carefully note what the results are, will soon become as well informed on the subject as any of the so-called experts.

The history of steam engine valves and valve motion is a curious study and brings the investigator in touch with a

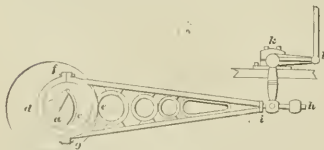

FIG. 3. THE ECCENTRIC AS FIRST USED BY GEORGE STEPHENSON.

world of high hopes reposed on a design or appliance that promised to bring fame and fortune to the inventor, and too often ended in bitter disappointment, sometimes in financial ruin. Inventors have too often misunderstood what the true functions of

\*This is part of a historical article for my forthcoming book, "Development of the Locomotive Engine." If readers find mistakes of facts, they will oblige me very much by pointing them out. ANGUS SINCLAIR.

an engine valve are, and how far the mechanism that drives the valve influences the distribution of steam.

SIMPLEST FORM OF VALVES.

In its most elementary form a valve is a device for opening and closing a

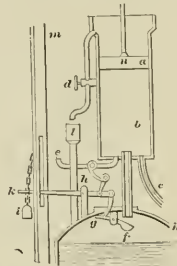

FIG. 2. NEWCOMEN ENGINE, SHOWING FLAP ADMISSION VALVE.

hole, the most primitive valve having been a door. Ancient temples had self-closing doors, and they were called valves.

The first appliance now regarded as a valve, performing the functions of opening and closing an aperture, was used on the bellows. That implement must have been employed by the person who first smelted metal, so this form of valve is a very ancient device.

Among the discoveries of Egyptian monuments, figures were found in a tomb at Thebes which bears the name of Thothmes III, one of the Pharaohs, who was contemporary with Moses. These figures illustrate blacksmiths at work, using bellows provided with self-acting valves.

In a fire engine described by Hero of Alexandria in his treatise on mechanism known as the "Spiritalia," two metallic pistons are used, and spindle valves with guards to prevent the latter from rising too far. Another apparatus illustrated in the same work is the lustral vase shown in Fig. 1, which was used in the Temple of Isis, in Egypt, many centuries before the Christian era began. The vase contained holy water, and was placed at the entrance to the temple. Before a worshiper could enter, a libation of holy water had to be procured. This was done by dropping coins through a slot at the top of the vase, and they fell into the dish *R*, raising the spindle valve inside the cylinder, permitting a small quantity of water to run out through the pipe connected with the valve.

Besides illustrating a very ancient

valve, this vase shows what may be regarded as the original penny in the slot apparatus. It also shows the first form of piston valve.

REAL PURPOSE OF AN ENGINE VALVE.

The essential work of an engine valve is to admit the steam required in the cylinder and then cut off the supply when the necessary volume has been admitted. With the great mass of high pressure engines the valve has been used to regulate an exhaust opening to permit the steam to pass out after it has done its work. This has been almost invariably the case with the kind of valves used on locomotives.

FIRST PRACTICAL ENGINES.

The first practical steam engine, that made by Newcomen, had the steam pipe leading directly into the cylinder. Admission of steam was regulated first by a plug cock, which, proving unsatisfactory, was replaced by a flap valve, illustrated in *f*, Fig. 2. The ideas of progress led to the use of a flat sliding valve for this purpose in the later forms of Newcomen engines.

Watt employed a variety of valves for controlling the steam passages, the puppet, a disk with short stem, having been his favorite. Spindle disk valves and slide valves were also used to a considerable extent.

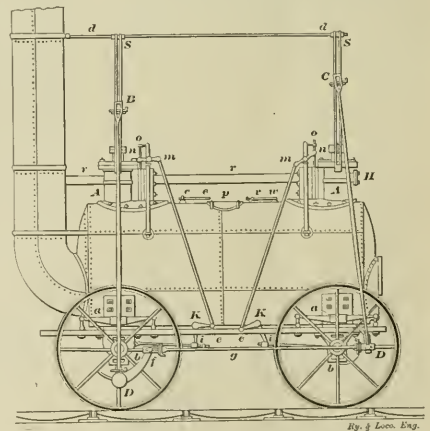

FIG. 4. FIRST USE OF AN ECCENTRIC ON LOCOMOTIVES.

The first attempt to make a successful peripatetic steam moved carriage was by Cugnot, a French engineer, who in 1771 made a steam carriage intended for military purposes, now preserved in the Conservatoire des Arts et Metiers, Paris. It is a single acting, double cylinder engine, the steam distribution being regulated by a four way cock.

MURDOCH'S EXPERIMENTS ON LOCOMOTION.

Next in order among the inventors who tried to apply steam to locomotion was William Murdoch, one of

James Watt's best assistants, and known to fame as the inventor of the first system of gas illumination. Murdoch sincerely believed that steam could be successfully applied to locomotion, and in 1784 he proceeded during his leisure hours to make a working model of a small steam engine and carriage. Murdoch was a most skilful

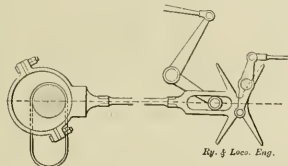

FIG. 5. CARMICHAEL'S VALVE GEAR.

mechanic and far seeing engineer, so it was fair to believe that his model would be a creditable production. It was so small that steam was generated by a spirit lamp, but the engine worked perfectly. It was a single cylinder, 3/4-in. by 3-in., single acting engine, and had a double headed piston valve with a hollow stem, through which the exhaust steam escaped.

In the first trial he made of this tiny engine Murdoch received an impressive lesson concerning revolution velocity. Experience with the slow moving, ponderous low pressure engines in use did not lead people to think that there were possibilities of real velocity in steam. Murdoch was living on the outskirts of Rudruth, a Cornish town, and near a parsonage approached by the best road in the neighborhood. His engine was mounted on a small tricycle, which he determined to try on the parsonage road. One dark night he stole out of his lodgings with the tricycle under his arm, and set it down pointing straight to the church. The spirit lamp was lighted, and quickly generated a head of steam. Thinking the thing would start off slowly, Murdoch opened the throttle valve, and away the tiny carriage flew like a bird, the inventor chas-

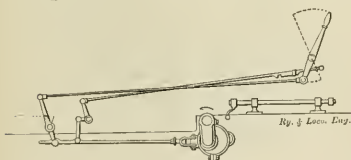

FIG. 6. BURY'S DROP HOOK GEAR.

ing after it. The parson happened to be out walking on the road when the puffing, fiery sprite approached. The man of God yelled and took to his heels, thinking that a real, personal devil was making a visit to his parish.

Watt, who, notwithstanding his inventive ability, was a weakly jealous man, objected to the experiment made by Murdoch, and the interesting toy

was laid aside, and is still preserved in the successor to the Boulton & Watt Engineering Works.

Murdoch began applying the slide valve to stationary engines, and he has been credited with inventing that form of valve, but that is a mistake, the valve having been described in Hero's "Spiritalia," and tried tentatively by various experimenters during the renaissance of mechanical science.

When Richard Trevithick, the first man to build a locomotive to run on a railway, began his experiments in locomotive engineering, it was with a steam carriage to run on common roads. He used a single cylinder, and the valve gear consisted of plug cocks. In his locomotive proper, built in 1803, a slide valve was employed, operated by a tappit rod, an arrangement with projections to "tap" the valve connections.

Although Trevithick's locomotive was abandoned after a few trials, the valve motion part seems to have left its mark, for on nearly all locomotives, experimental and otherwise, subsequently

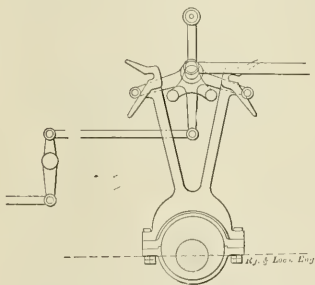

FIG. 7. FORRESTER'S VALVE GEAR.

built, the slide valve was employed, actuated in various ways.

THE ECCENTRIC APPEARS.

The use of the slide valve was a decided step toward modern conditions, and the long popularity it has enjoyed proves it to have been a case of the survival of the fittest. The student of locomotive valve gear development naturally looks for the next step, and finds it to be the application of the eccentric for producing movements coincidental to the movement of the cranks. The word "eccentric" is formed of two words, "ex centric"—out of center. The inventor of the eccentric pulley, a disk secured away from the center on an axle, which produces the same kind of motion as a crank, is not known. It is like the crank, valve lap and many other devices used in engineering that have been applied without inventor's claims and have gained popularity through efficiency, by being better in their purpose than any other attachment. Murdoch receives the credit from some writers of having invented the eccentric, but others say that it was in use in pump-

ing apparatus long before his day. He merely revived a device that was dead for want of use, a thing that has happened very often in engineering.

The first illustration of the eccentric (Figs. 3 and 4) being used on a locomotive engine can be found in Woods' "Treatise on Rail Roads," published in 1830, and relates to George Stephenson's Killingworth engine, built in 1815.

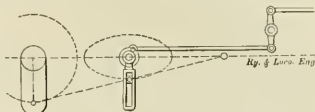

FIG. 8. MELLING'S RADIAL GEAR.

The invention is thus described: The sliding or steam valve is opened and shut at the proper periods by the following contrivance; *a*, Fig. 3, represents the axle of the traveling wheels of the carriage; *ab* is a lever fastened upon, and turning round, at the same time with it; *b c* is a circular opening in the eccentric circle *d e*, within which a pin, attached to the end of the lever *a b*, is at liberty to move; this eccentric circle is loose upon the axle of the carriage, and is only turned round when the pin, at the end of the lever *a b*, arrives at *b a c*, according to the direction in which it is moving; a circular hoop or strap of iron fits the circumference of the eccentric motion, connected to the lever *f g h*, which is moved backward and forward as the axle turns round; as this lever is moved, its motion is communicated to the arm *i k*, as shown, in Fig. 4, also, and through it, by the lever *k l* and rod *l m*, to the crosshead *m n*, and so to the rod *n o*, of the sliding or steam valve, which, as the carriage is moved forward, is thus worked up and down to open and shut the communication between the two sides of the cylinder and the boiler at the proper periods."

The eccentrics were engaged in front and back gear by two clutches fastened to the axle, one behind each crank, the

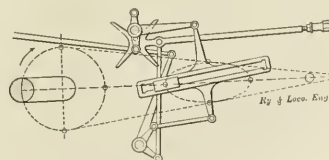

FIG. 9. HAWTHORN'S RADIAL GEAR.

locking of the eccentrics being accomplished by a forcible lateral motion. It made a very efficient reversing device and was highly superior to anything previously used.

It will be seen from the illustration that the introduction of the eccentric to drive the valves of a locomotive was accompanied by the use of the rocker shaft, which was soon abandoned in

European practice, and years afterward became a regular arrangement on American locomotives.

#### OBJECTION TO LOOSE ECCENTRICS.

Loose eccentrics worked fairly well on the slow moving locomotives used for hauling coal, the speed seldom exceeding six miles an hour; but when the time of higher speeds arrived, the inventive genius of two continents was

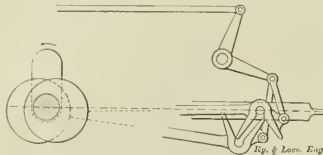

FIG. 10. PACWELS' VALVE GEAR.

stirred to devise something that would endure the shocks of quick reversal. The mechanism that proved the most successful on early locomotives, and was modified in a multitude of ways, was invented by J. & C. Carmichael, of Dundee, Scotland, in 1818, for use on a steamboat. It was what in Britain was known as the gab hook, and in America as the V-hook, and is illustrated in Fig. 5. A single fixed eccentric had double forks at the end of the eccentric rod, working on a rocker arm having two actuating pins. When the hook engaged one pin the steam was distributed to move the engine forward; when it took hold of the other pin, backward motion was produced.

Practically the same arrangement was used for several years by Mr. Baldwin; employed, in fact, until the double eccentric became popular.

#### THE DROP HOOK.

Bury, the famous English locomotive builder, whose engines exerted so much influence on American locomotive practice, used at first a drop hook motion, shown in Fig. 6. A very decided objection to that motion was that four handles were necessary to operate the valve gear. The older race of American engineers remember this motion as having been used on nearly all New England built engines of early days, and it was on the Braithwaite engines used in the opening of the Philadelphia & Reading Railroad.

During the first two decades of railway operation, from 1830 to 1850, one of the greatest problems worked on by locomotive engineers was striving to produce a reversing and valve actuating mechanism that would give fair durability in service. Many wonderful contrivances were produced that received application through influential friends and were kept in operation long enough to be a dreadful example concerning the evils of complicated mechanism, and then disappeared.

Forrester & Co. of Liverpool, experi-

enced machine makers, built a set of locomotives which obtained the nickname of "Boxers," which had the valve gear shown in Fig. 7. The motion was taken from a single eccentric, and was located directly above the axle. A critic said that the only merit this motion had was that it frightened the crows away from the farmers' fields along the route where the engines were in operation.

#### DOUBLE ECCENTRICS.

Double eccentrics were introduced into European practice by the Hawthorns, of Newcastle, in 1837, and, like many other parts of locomotive improved mechanism, it is not known with certainty who first proposed the arrangement. It was, however, a very important advance movement, and prepared the way for the introduction of the link.

William T. James, of New York, used double eccentrics and a link motion in the United States as early as 1832, but the boiler of his engine exploded, destroying the whole engine, which was never rebuilt. It is not known if the double eccentric was his own invention or that of some of the

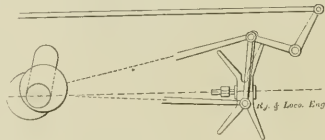

[FIG. 11. STEPHENSON'S VALVE GEAR.

steamboat engineers then actively working out engineering improvements on American waters. The locomotive, however, did more than anything else to give the double eccentric popularity. They began to be used in the United States about 1835, and grew steadily into favor.

#### FIRST RADIAL VALVE GEAR.

While the agitation devoted to improving valve mechanism was in progress, what afterward became known as "radial" motions first appeared. About 1832 a Mr. Melling, connected with the Liverpool & Manchester Railway, devised the motion shown in Fig. 8. He secured a pin on the middle of the connecting rod, which, by the nature of connecting rod motion, describes a species of elliptic curve, since become familiar to engineers through the action of Joy's valve motion, developed years afterward. The pin worked in a slotted lever, of which the axis was placed in the center of the oval. The motion did not become popular, probably on account of its novelty, although it appeared to be a great improvement upon the labyrinth of rods, levers, pins, slots and hooks used as valve motion by some locomotive builders.

Another radial motion was introduced by Hawthorn & Co., Newcastle, about 1837, shown in Fig. 9. This motion, like that of Melling, is actuated by a pin on the side of the connecting rod, and worked in a slotted link that transmitted only the vertical motion of the pin to the valve levers.

Among the early European valve gears that nearly approached the link in simplicity was that designed by M. Pauwels, a French engineer, about 1840, and shown in Fig. 10. He used the forked rods, placing them facing one another and linked to the reversing shaft above. A modification of this gear became the favorite V-hook gear of the United States.

The Stephenson valve gear of 1840, shown in Fig. 11, was also about as simple as a motion of the kind could be made.

Very different from these was the Gray expansion gear of 1839, shown in Fig. 12, which was one of the first attempts to design an expansion gear without having an independent cut-off. This is a crude sort of link motion. The pin of the eccentric rod worked in a segmental lever curved to the radius of the rod, the upper end of which was linked to the valve stem. This lever being concentric with the one rod at the beginning of the stroke, the rod could be raised or lowered in the slot of the lever to any required distance from the fulcrum which regulated the travel of the valve. Varying the travel of the valve, of course, produced varying admission of steam.

Another curious looking expansion gear was that brought out in 1843 by Crampton, shown in Fig. 13. This was a direct development of Carmichael's gear, and operated with a single eccentric.

#### ROBERTS' VALVE MECHANISMS.

During the period when inventors and engineers were searching for a valve motion that would be simple and

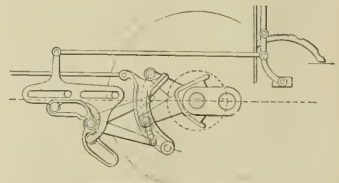

FIG. 12. GRAY'S EXPANSION VALVE GEAR.

yet provide for the working of steam expansively, several ingenious kinds of valve mechanism were produced. Richard Roberts, of Manchester, in 1832 invented the motion shown in Fig. 14. The valve of wrought iron was formed of two concentric tubes, *a* and *b*, the larger pipe, *b*, having holes perforated

at *o* to admit steam from the steam pipe into the annular space between *a* and *b*. This annular space was closed steam-tight at each end of the valve, and steam could only escape from it alternately to each end of the cylinder through the slots *g* and *g'*. The exhaust steam from one end of the cylinder

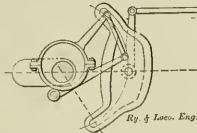

Fig. 13. Crampton's Expansion Gear.

FIG. 13. CRAMPTON'S EXPANSION GEAR.

went directly into the exhaust pipe, and from the other end it traversed the interior of the tube (*a*) of the cylindrical valve. These valves did not work well, as they did not expand equally with the cast iron casings when heated by steam.

Mr. Roberts also invented a valve motion in which the valves were worked by mechanism connected from the opposite side of the engine. No eccentrics were used, the movement being taken from a pin on the main rod.

Another ingenious production of the same engineer was a variable expansion gear, in which a supplementary valve worked in a casing at the back of the principal steam valve. This invention became the basis of many variable expansion gears used in America, the Cuyahoga cut-off, that became quite popular, having been one of them.

EASTWICK'S REVERSING MOTION.

A very curious form of reversing gear, illustrated in Fig. 15, was invented by Andrew M. Eastwick, of the Eastwick & Harrison firm of locomotive builders, in Philadelphia, and largely used on Russian locomotives. Instead of reversing the eccentric or the valve, the valve seat was moved. In Fig. 15

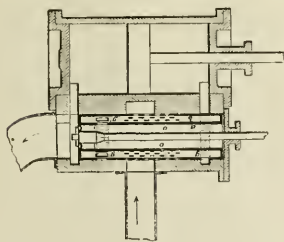

FIG. 14. ROBERTS' PISTON VALVE.

*E* is the slide valve and *F* a movable seat. When the block is set as in the middle figure, the front edge of the valve *E* admits steam to the front of the cylinder. By moving the block *F* a short distance, the steam admitted under the front edge of the valve *E* was

conducted by another passage to the back of the cylinder.

INVENTION OF THE LINK MOTION.

It has been proved beyond question that the link motion was first designed by that erratic genius, William T. James, of New York, as a simple form of reversing gear. It was applied to a locomotive built for the Baltimore & Ohio Railroad, but the boiler having exploded, the invention was lost. In 1843 it was reinvented in the Stephenson Locomotive Works, at Newcastle, England.

A man named William Howe has been credited with inventing the link motion, but there is good reason for believing that Howe was merely a smart rogue who succeeded in making his employers and the world believe that he was the author of an invention that another man conceived.

In August, 1893, appeared in RAILWAY AND LOCOMOTIVE ENGINEERING an article written by James Hedley, a grand-nephew of William Hedley, builder of the historic locomotive, "Puffing Billy," and father of Frank Hedley, general



FIG. 15. EASTWICK'S REVERSING MOTION.

manager of the Interborough Rapid Transit, of New York, which said:

"About the year 1843, I was at that time serving my time with Stephenson as mechanical engineer. There was also in the shops at that time a young fellow named William Williams, and Mr. William Hutchinson was manager for Stephenson, having charge of the shops at Newcastle. A man named William Howe was foreman in the pattern shop. Williams was the man who invented the link motion. He made the drawings and gave the idea to Howe for him to make a small wooden model from. After Howe had got all the details from Williams, he kept Williams at bay, promising daily that the model should be handed over to him; but that time never came. A short time afterward Mr. Hutchinson called Williams into his office and showed him the model that Howe had made from the drawings that Williams had given him, leading Mr. Hutchinson to believe that it was his own invention.

"The result was that Messrs. George and Robert Stephenson were sent for and investigated the matter; the only alteration that Howe had made was—Williams' link was straight, and Howe put the curve to the one that he showed to Mr. Hutchinson. Hence it was that a patent was never obtained for the link."

In the *American Machinist* of March, 1904, is published a long interview with Mr. Ralph Little Whyte, who is still living in Hamilton, Ont. Mr. Whyte was the draftsman in the Stephenson works who laid down the first link motion in a working drawing, and he

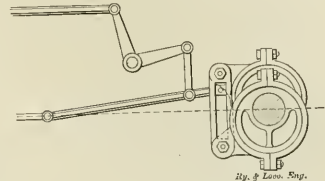

Fig. 16. Pretended Williams' Link Motion.

FIG. 16. PRETENDED WILLIAMS' LINK MOTION.

asserts positively that Williams was the inventor of the link motion.

In most treatises on the locomotive that deal with the invention of the link motion the statement is made that a youth named Williams made a sketch similar to that of Fig. 16, and that Howe, the foreman pattern maker in the Stephenson works, worked it out into the form shown in Fig. 17. Mr. Whyte says positively that such a statement was a distortion of facts; that Williams drew a sketch similar to Fig. 17, but with a straight link, and it was given to Howe to make a pattern from. Howe made the pattern, and then pretended that he had invented the arrangement.

In 1846 the *Glasgow Practical Mechanic* published a series of articles describing the various forms of valve motion that had been in use up to that time, and on the link motion said this "elegant apparatus" was invented by Mr. Williams. In the following month it told that a communication had been received from William Howe, claiming to be the inventor of the link motion and sending the sketch of Fig. 16, saying that was

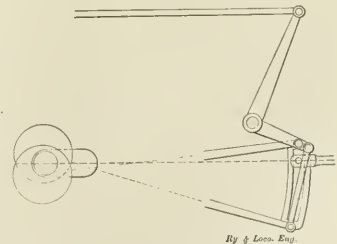

Fig. 17. Original Link Motion.

FIG. 17. ORIGINAL LINK MOTION.

Williams' invention. If Williams gave the suggestion of the link in that form he was the real inventor, but we prefer to take the testimony of Hedley and Whyte that the link as produced by Williams was attached to the ends of the eccentric rods.

# Railway and Locomotive Engineering

A Practical Journal of Railway Motive Power and Rolling Stock.

Published Monthly by

ANGUS SINCLAIR CO.,

136 Liberty Street, New York.

Telephone, 984 Cortlandt.

Cable address, "Loceng," N. Y.  
Glasgow "Locauto."

## Business Department:

ANGUS SINCLAIR, President.  
FRED M. NELLIS, Vice-President.  
JAMES R. PATERSON, Sec'y and Treas.

## Editorial Department:

ANGUS SINCLAIR, Editor.  
GEO. S. HODGINS,  
JAMES KENNEDY, Associate Editors.  
J. P. KELLY,

## Advertising Department:

Eastern Representative, S. I. CARPENTER, 170 Summer St., Boston, Mass.

## British Representative:

THE LOCOMOTIVE PUBLISHING CO. Ltd., Amen Corner, Paternoster Row, London, E. C.

## Glasgow Representative:

A. F. SINCLAIR, 15 Manor Road, Belahouston, Glasgow.

## SUBSCRIPTION PRICE.

\$3.00 per year, \$1.00 for six months, postage paid in the United States, Canada and Mexico. For other parts of the world, \$3.50 or ten shillings. Single copies, 20 cents. Remit by Express Money Order, Draft, Post Office Order or Registered Letter. Mailing address can be changed as often as necessary—always give old and new address, and if you subscribed in a club, state who got it up. Please give prompt notice when your paper fails to reach you properly.

Entered at Post Office, New York, as Second-class mail matter.

Copyright by Angus Sinclair Co., 1906.

For Sale by Newsdealers Everywhere.

## Very Ancient Device.

The piston was the element that first made the steam engine successful, yet inventors were a long time in realizing that a disk of metal working in a steam-tight cylinder was the proper way to harness the elastic power of steam to convert it into useful work. Yet the piston had been tried many times hundreds of years before Newcomen made his engine a success by using the piston. There lived in Alexandria about 2,100 years ago a philosopher named Hero, who published a treatise on pneumatics which contained descriptions of a great many engineering devices that had been invented for water raising and other purposes. Among the inventions he described was a piston working in a cylinder. Many years later the piston was used as a plunger of a water pump and it became popular for that purpose, but in such cases it was driven by outward power and it took a long time for inventors to perceive that it might be made the medium of power.

The first philosopher to propose the use of a piston to transmit power was Jean Hautefeuille, a French priest of inventive tendencies. Among other power engines in 1678, he proposed one with a piston to be driven by charges of gunpowder. There is no record that

such an engine was ever built, but the idea took root. It will thus be seen that the first proposal to use a piston for power purposes was as a gas engine.

The idea was adopted by Christian Huyghens, a Dutch philosopher, who in 1680 presented to the French Academy of Science a memoir in which he described a gas engine which is regarded as the prototype of the Otto and Langen explosive gas engine.

By this time the necessity for the steam engine was becoming very urgent in Great Britain, as great mining properties were going to ruin through the impracticability of concentrating animal power for the pumping of deep mines. For a time inventors tried to apply steam to raising water by direct pressure as water is raised by air pressure in sleeping cars; and sometimes by suction into a vacuum created by condensing steam. But these processes were very expensive; and it was not till 1705, when Thomas Newcomen, a blacksmith, of Dartmouth, England, applied a piston to a cylinder where power was created by the condensation of steam that the elements of a practicable steam engine were connected together.

To Newcomen, therefore, must be given the credit of being the inventor of the steam engine, since he discovered the combination of mechanism that was afterwards developed by others. James Watt, Oliver Evans, Robert Fulton, Richard Trevithick, George Corliss and a host of other inventors were merely the disciples of the apostle Newcomen, who led the inventive world out of the wilderness of speculative uncertainty to the light of productive action.

## Rational Criticism Made Effective.

The Baltimore & Ohio recently adopted a very practical way of getting the consensus of opinion from their mechanical department employees. The company had an engine of the mogul type as specified by them built by the American Locomotive Company and delivered before any others of the same class were put under way. The motive power superintendent, Mr. J. E. Mulfeld, appointed three committees to deal with this engine. One committee consisted of the S. M. P. himself, assisted by the mechanical engineer, the engineer of tests, and the shop master mechanics. Another committee consisted of the divisional master mechanics, and the third committee was made up of the road foremen of engines on each division. Each of the road foremen brought with him a locomotive engineer and a fireman from his district.

The sample engine, which was the first of an order of 210, was disconnected and certain parts were taken down and ex-

amined by each of the committees. Thus was the design and workmanship subjected to a critical examination and at close range. After all had scrutinized the engine, piecemeal, so to speak, it was connected up and put under steam, and its performance was watched by the same committees and reports from each on the construction and the operation of the engine were handed in.

The reports, as might be expected, contained valuable suggestions from men who not only were responsible for the design, but from representatives of those who would have to operate the engine on the road, and such of these suggestions as were approved by the superintendents of motive power were used in connection with the rest of the engines which were on order. In this way a thoroughly practical criticism and service test were secured while yet there was time to make desired changes. This method has practically the effect of forestalling the mere faultfinder and at the same time gives the B. & O. the advantage of expert opinions from several quarters.

## First Railway Guide.

People who patronize railways and steamer lines in Europe find an unflinching guide, reference and friend in "Bradshaw," just as our travelers repose faith in the "Official Guide." Bradshaw is even more of a companion and divides with "Baedeker" the waking attention of globe trotters who would be lonely indeed without its pages to pore over. Bradshaw was the first commercial railway time table and was begun by George Bradshaw, a Quaker engraver, of Manchester, in 1830. The first issue was a tiny pamphlet bound in green cloth, and was nothing more than a collection of the monthly time tables issued by the seven railway companies then in existence in England. Of this volume there are now only four copies in existence, but they are worth their weight in gold.

So encouraged was Bradshaw by the success of this time table that in 1840 he published his "Railway Companion," a volume of thirty-eight pages with maps which sold at a shilling. These early guides were published rather irregularly because of the difficulty of learning the changes in times from the railway authorities. They resented Bradshaw's interference and put every obstacle in the way of his obtaining information. At last, through the Quaker's perseverance, they finally agreed to adjust their time tables by the beginning of the month. Thereafter it was smooth sailing. The guide continued to grow and prosper and to make itself a necessity.

These early railway guides make interesting reading. The trains are described as first class, second class, mixed, fast and mail. Third class travelers had the

choice of sitting on the roofs or in open wagons resembling cattle trucks. Gentlemen riding in their own carriages were charged second class fare. Baggage was carried on the roof, and passengers who sat there were cautioned to wear their overcoats and provide themselves with gauze spectacles. First class fare between London and Birmingham was nearly double what it is to-day, and an annual subscription ticket from London to Brighton and back cost five hundred dollars.

### Marvelous Speed.

The extraordinary velocity attained by the racing automobile not only establishes new records of speed for any kind of power driven vessel but sets the racing men and engineering world conjecturing on the limit of speed possibilities. Until the automobile appeared the steam locomotive was easily the fastest motor in the world; yet after ninety years of developing the limit of locomotive speed was little over one mile per minute or 60 miles an hour. Under extraordinary circumstances a train speed of about 90 miles an hour has been maintained for a short time, but records of speed above that have generally been the loose time taken by newspaper reporters' watches.

It is possible to concentrate immense power in an electrically driven motor, and we have no doubt that the leading electric companies in this country could produce a motor and drive it at a velocity of 200 miles an hour; but it would not be a commercial enterprise, hence it is not likely to be done in the near future. Several years ago a series of experiments were made for scientific purposes on the Berlin-Zossen electric railway in Germany, and a speed of 127 miles an hour was attained, but there was nothing extraordinary in it to people familiar with transmission-of-power problems.

But that a vehicle weighing less than 1,700 lbs. should carry its own power and endure the strains necessary to drive it over two miles a minute is, indeed, marvelous.

The first day of the 1906 Florida automobile races promised that the perfecting, elaborating and adjusting of vehicles and mechanism during the last year would prove that the scientific labors had not been in vain. Marriott, in a Stanley steamer, opened the high-speed ball by passing over a mile in 32½ seconds, or 164 ft. per second. This speed would go over two uptown blocks in New York City every three seconds. As the races proceeded one mile in 40 seconds became commonplace, although it is 90 miles an hour and practically the limit of high speed locomotive velocity. Before the first day closed the Stanley steamer bettered its

record slightly, making a mile in 31½ seconds, at the rate of 166 feet per second.

The finishing day saw the climax of high speed racing when first Marriott ran over the two mile course in 1.03 minutes, which he bettered by covering the distance in 59¾ seconds. This was, however, beaten by Demogeot, who ran the Darraq car the two miles in 58¾ seconds, or a little better than a velocity of 124 miles an hour, or 180.8 feet per second.

These figures indicate that there was remarkably small difference between the speed capabilities of well designed and properly made steam and electric cars. It is properly applied power that produces speed in any vehicle, so that given an equal weight and measure of resistance a unit of power will produce equal speed.

There is nothing in engineering experience to compare with the velocity attained by the racing motors, except that of projectiles or of falling bodies. A body would require to fall over 500 ft. to acquire the velocity attained by the automobile run by Mr. Demogeot.

But the capability of these racing machines is not confined to short spurts of one or two miles. An important event in the contest was the one hundred miles race which was won by Walter Clifford Earp with a 50 h.p., six-cylinder Napier car in 75 minutes, 40¾ seconds, a running speed of 79.5 miles an hour. A most remarkable incident of this race was that one of the tires collapsed and 63 miles of the distance was run on three tires and a rim.

Second to that performance was Emanuel Cedrino, who ran a Fiat over the distance in 76 minutes 39 seconds. The victory nearly came to this car, for it made the first forty miles in 25 minutes 6 seconds, an average of 95.7 miles an hour, and then was thrown back by a fractured tire.

### Electric and Steam Locomotives.

One of the most important papers read before the members of the New York Railroad Club for some time past was presented by Mr. J. E. Muhlfield, general superintendent of motive power of the Baltimore & Ohio Railroad, on the subject of large electric and steam locomotives. The comparisons were drawn from records carefully compiled under Mr. Muhlfield's supervision and the tests of efficiency, and the items of expenditure were recorded under conditions that preclude the possibility of any other motive than that of securing a just estimate of the advantages or disadvantages of the motive power used.

Six electric locomotives are in use at Baltimore on the B. & O. system, four of them having been in use for a period

of ten years, and the total cost of operating and maintenance, including the generation of the electric current, besides general miscellaneous expenses, has been approximately \$34.50 per hundred miles run per locomotive. Of this amount the running and shop repairs averaged \$6.10 per hundred miles. In the case of the steam locomotive the expenses of maintenance averages \$24.50 per hundred miles run, or 30 per cent. less than that of the electric engines under fairly similar conditions. Of this expense the shop repairs for labor and material of all kinds amounted to \$3.16 per 100 miles, or nearly 50 per cent. less than that of the electrically driven locomotive.

It also must be borne in mind that these figures are not all. The fact was brought out that electric locomotives, where the source of power is separate from the machine which develops the hauling capacity, the first cost of the locomotive alone is, at the present time, about 50 per cent. greater per pound of tractive power than for steam locomotives. To this must be added the greater cost of maintenance and operation of a current producing and distributing system, which is not required by an internal combustion locomotive. In electric locomotives also, the excessive weight concentrated on a short rigid driving wheel base results in extraordinary rail pressure which would be difficult to estimate in actual cost in the wear of rails. In the steam locomotives, especially in the articulated type, the highest degree of tractive power has been attained, as it can be readily imagined that when one engine begins to slip, the other engine meantime is gaining power, thereby preventing the stalling of a train at a critical moment.

The conclusions carry out the general and growing impression that electric locomotives are better suited for the handling of suburban passenger traffic than they are for heavy or freight traffic, and it does not seem to be within the range of possibility that electricity will supercede steam as a motive power for the handling of heavy tonnage for any considerable distance. Indeed, it may, as Mr. Muhlfield pointedly stated, make the use of heavy electric locomotives as compared with steam locomotives prohibitive, except in cases of absolute necessity.

In the interesting discussion which followed, some of the leading electric experts claimed that the limit of the capacity of steam locomotives had been reached on the New York Elevated Railroad, and that the change to electric driven motors had become a necessity. They seemed to have overlooked the fact that the passenger traffic on the elevated roads is about 20 per cent. less at the present time than it was

when the steam locomotives were in operation, owing to the relief that has been obtained by the opening of the Subway and other improved avenues of transit. The advantages of the electric motor in city or suburban traffic is not based on any marked increase of speed or decrease of cost, but from the fact that there is less dust and noise and no ashes, and in running short distances there is an undoubted advantage in the more rapid acceleration of speed.

The absolute fairness which characterized Mr. Muhlfield's carefully prepared paper, and the able comments which it drew forth, are of such importance that in a published form it merits a wide circulation. The superiority of the heaviest kind of steam locomotive was very clearly demonstrated in all kinds of traffic involving distances of over a few miles. The Mallet four-cylinder articulated compound, built for the B. & O. by the American Locomotive Company, was claimed by Mr. Muhlfield as being in every essential eminently superior to any combination of electric motors of equal tractive force, and while the electric experts persisted in claiming that the electric locomotive was still largely in the experimental stage, Mr. Muhlfield cleverly maintained that the Mallet articulated compound was also an experiment and a very successful one, whereas the electric motors recently put in operation by the B. & O. Company were not as satisfactory as those that were put in service ten years ago. The fact came out very clearly that the electric locomotive reaches its most advantageous capacity in a single car of 10 or 15 tons, and beyond that limit the expenses of operation are largely in excess of that for similar service by steam locomotives.

#### Electricity vs. Steam.

The conclusions drawn from the study of the whole subject as set forth in his paper on "Electric and Steam Locomotives," were briefly summarized by Mr. Muhlfield as follows:

1. A tractive power of about 84,000 lbs. for starting heavy trains and for a speed of 5 miles per hour; and of 74,000 lbs. at a speed of 10 miles per hour, placed under the control of one engineer and one fireman.

2. A self-contained machine generating the power necessary to develop its hauling capacity. With electric locomotives, where the source of power is separate from the machine which develops the hauling capacity, the first cost of the locomotive alone is, at present, about 50 per cent. greater per pound of tractive power developed under working load than for steam locomotives of the 2400 type. To this must

be added the greater cost for repairs and operation per mile run for the electric locomotive, and the installation, maintenance and operation of a current producing, conveying, storage, converting and distributing system, which would not be required by either a steam or an internal combustion locomotive, and all of which increase the capital and operating expenses very materially.

3. A total locomotive weight utilized for the development of tractive power in connection with a running gear, which makes the locomotive suitable for either hauling, pushing or braking freight trains containing the maximum paying load per foot of track space, over level or mountainous railroads of maximum curvature.

4. A maximum tractive power with a minimum rail pressure per driver wheel, on account of the total weight of 334,500 lbs. being distributed over 12 drivers, and a 30 ft. 6 in. total, with a 10-ft. rigid wheel base, resulting in minimum wear and tear on bridges, rails, ties and roadway. With electrical locomotives the excessive weight concentrated on a short rigid driver wheel base and below the springs, together with the extremely low center of gravity, results in extraordinary rail pressures, thrusts and wear.

5. The elimination of retarded movement and stalling of trains, on account of the usual slipping of driver wheels, as in the case of ordinary simple or compound cylinder steam locomotives, or with electric locomotives where the driver wheels are uncoupled and the current is naturally transmitted to the point of least resistance, which is the slipping wheels, resulting in no increase of power at the dead wheels. A higher tractive power is obtained to the weight per axle than with the ordinary steam locomotive, as the slipping due to the accumulation of high unbalanced pressure at the points of wheel and rail contact, does not occur at the same time in both engines. When one engine commences to slip a reduction in mean effective pressure follows, and it regains its grip on the rail without making it necessary to shut off or throttle the steam supply. The other engine, meantime, has been gaining power, thus preventing any loss of speed and consequent stalling of the train at a critical moment. These conditions are the same whether the slipping occurs with either the high or the low pressure engine, and the most frequent cause for stalling with electric or simple cylinder locomotive is thus overcome.

6. A tonnage and speed per train that will provide for the least number of locomotives and crews under the control of which the movement of the business is placed. This will result in the balancing of the power and move-

ment of the maximum number of loaded and empty cars per hour over a single piece of track, with the proper degree of safety.

7. A minimum capital, repair, fuel, engine and train crew, oil, supply and dispatchment cost per locomotive, train, car or ton mile.

8. A maximum retarding effect for the safe handling of heavy trains down steep grades at the highest speed permissible for a proper degree of safety.

9. A uniform turning movement to overcome journal friction of axles; rolling and flange friction of wheels; wave resistance of rail; atmospheric friction at ends and sides of rolling stock and inertia of train at time of starting, which will insure the minimum draft gear, machinery and boiler stresses, and reduce the tire and rail wear.

10. A sub-division of power and balancing, resulting in the minimum strains on the locomotive and track, and a reduced liability for wear, breakage or accident. Broken driver wheel axles on electric locomotives indicate that the more uniform torque does not eliminate the liability for such failures under normal conditions.

11. The minimum amount of dead weight and non-paying load, and the smallest number of bearings and parts per unit of power developed.

12. Ability to move itself and train of one-half rating in the event one set of its machinery or engines becomes disabled.

#### The President's Train.

The New York Sun makes a suggestion pertaining to the question of the President's railway transportation which, we believe, now represents the sentiment of practically all citizens who have thought upon the subject. The Sun's proposal, in short, is to have a "President's train;" or, in less picturesque but more exact language, to have Congress provide an annual appropriation to be used by the President in paying for his railroad transportation to and from points which he may be called upon to visit during the period of his administration.

The public good demands that the Chief Executive of the nation should be protected from the temptation of placing himself under obligations to the railroad corporations. It is unfair to the President to demand that he pay for these junkets, which are made generally in response to the public desire, out of his personal funds. But it is even more unfair to the public to allow a condition to maintain which forces the President to ask favors of the railroads.

The best solution of the difficulty, we believe, is that advanced by The Sun.



Let Congress provide an annual appropriation for meeting the traveling expenses of the President. It will be worth many times more than the cost simply to quell the suspicions which are aroused by the spectacle of a President loudly vociferating his demands for railroad regulation in one breath, while in the next he asks for a special train.

#### Railroads as Merchants.

A very important decision has recently been rendered by the Supreme Court of the United States in a suit brought by the Interstate Commerce Commission in the U. S. Circuit Court of West Virginia, to restrain the C. & O. from carrying out a certain contract to sell and deliver coal to the N. Y., N. H. & H. The price of the coal at the mines, plus the freight to New Haven, was \$3.92 per ton, while the C. & O. agreed to deliver it for \$2.75 per ton.

The decision confirms, while it enlarges the decision of the court below, and perpetually forbids the road in question from charging less for the transportation of the coal than the amount fixed in its published tariff of freight rates. The line of reasoning by which the court reaches its decision practically enunciates the doctrine that a railway company buying, transporting and selling any commodity may not make a price to its customer less than the sum of the amount paid to the producer, plus its own published freight charge for the carriage of the goods. This ruling, however, does not apply to anthracite coal roads whose charters were granted prior to the passing of the Interstate Commerce Act in 1887.

The pending railway rate law contemplates defining private lines as common carriers just as railway companies now are. If this provision goes into effect the Supreme Court decision can then be applied to them and they will have to follow this ruling just like ordinary railroads.

**RAILWAY AND LOCOMOTIVE ENGINEERING** advocated the buying up of the private line cars by the railways in the days when the private lines sought to continually impose a heavy maintenance charge for their cars upon railway companies. The probability of the private lines coming to be considered legally as common carriers may hasten the acquiring of these cars by railroad companies.

#### More Reliable Couplers Needed.

In the course of a discussion on car couplers at the New England Railroad Club, Mr. T. B. Purvis said: During the year ending June 30, 1904, there were 1,024 collisions caused by trains separating, at a total loss to the railroad companies of \$491,666, and with a loss of twenty-five lives and 412 employees injured. In the year ending June 30, 1905,

there were 972 collisions caused by trains separating, with a monetary loss to the railroad companies of \$440,495, and with eleven employees killed and 369 injured. The railroad men of the United States should feel proud that the record for 1905 is better than that which was made in 1904. All that I have to say in regard to increasing the variation of the height of couplers on freight cars is—speaking now from a purely humanitarian standpoint, for the sake of humanity and the reputation of the railroads of the United States—I hope that our railroad clubs will not take any action, will not do anything, that will tend to increase the figures as shown in 1905.

#### Revenge for Stoppage of Passes.

It is curious to witness the new-born zeal in favor of two cent per mile fares displayed by so-called statesmen connected with divers legislatures. The abolishing of free passes by railroad companies is a movement that inflicts widespread pain, but no one can deny that the railroad companies are within their rights in deciding to carry no more deadheads. Surely our high minded statesmen are not scheming to pass two cent fare bills as revenge for the non-appearance of their comforting pass. If two cent fares are fair, just and proper to-day, was it not fair and just last year? If a Congressman considers that a two cent fare was fair last year, but only had his conscience stirred to demand justice for his constituents after his own free rides were cut off, he is a miserable sneak. Every man introducing a two cent fare bill this year who made no mention of the thing formerly may be safely classed as a rascal.

#### Book Notices.

**Electrical Wiring, Diagrams and Switchboards,** by Newton Harrison. E.E. Published by The Norman W. Henley Publishing Company, New York. 1905. Price, \$1.50.

This book, which, with its index, has 272 pages, has been written by the instructor of electrical engineering in Newark Technical School, and is a practical treatise on all the varieties of electrical wiring. Problems encountered in actual practice are presented, and the solutions given. The explanations are rendered clear by diagrams. Higher mathematics are not employed, and the author has been at pains to work all his calculations out in simple arithmetic. Ohm's law of resistance is stated and elucidated with reference to the wiring for direct and for alternating currents, and the drop of potential in circuits is followed through its various applications. Mains, feeders and branches are set forth and house wiring with reference to them is dealt with and illustrated. Some simple facts about testing are

given, and moulding and conduit work are fully explained. The reader is introduced to the switchboard and these are systematically built up as the work proceeds. Alternating current wiring comes in for discussion and a simple way of getting the sizes of wire for single phase, two phase and three phase current is given. The book is an instructive and comprehensive work on all sorts of wiring for use by the foreman, contractor, electrician or the student in this branch of electrical work.

**Modern Machine Shop Construction, Equipment and Management,** by Oscar E. Perrigo, M.E. Published by the Norman W. Henley Publishing Company, New York, 1906. Price, \$5.00.

This is a book of 343 pages, 7x10 ins., and is a work designed for the practical and everyday use of architects, manufacturers, engineers, superintendents, foremen and workmen, and indeed all others who are in any way connected with or interested in machine shop construction.

The book is divided into three parts, Part I is devoted to construction and deals with the matter from the choice of a site, up to the completed plant. The matter of foundation, building, arrangement, heating, lighting and equipment are taken up and discussed in the light of modern practice. Those contemplating the rebuilding and reorganization of existing shops will find much to interest them in the pages of this book.

Part II takes up the subject of equipment and under this head the various departmental buildings and rooms for mechanical and administrative purposes are described. Each department is dealt with and its proper equipment of tools and machinery is specified. A complete system of shop transportation both for yards and buildings, such as traveling cranes, air hoists and all the usual appliances now employed are described.

The third part pertains to the management of the modern machine shop or manufacturing plant. In this section capitalization, manufacturing and selling are dwelt on and a comprehensive plan of shop organization is given and the author points out how to achieve success. The general routine work of management, from the general manager down to the workman, are duly set forth and the proper system of accounting and time keeping and cost keeping are explained.

The book is fully indexed and it is well illustrated throughout. It is a guide to those who are seeking knowledge on this very important subject and it forms a useful reference work for those who are connected with up-to-date machine shop practice.

### Box Car for Automobiles.

Men who draw cartoons for the comic papers often have a little fun at the expense of automobilists by representing a splendid modern motor car being hauled home by the much-despised horse. The Pennsylvania Railroad, however, are able to transport the automobile, whether broken down or in good condition, and in a way which is not calculated to hurt the tenderest susceptibilities. There are 100 specially designed box cars being built at the Altoona shops of the railroad, which have extra large doors, diagonally placed so that automobiles can be easily loaded and unloaded, and a long or short journey can be made without trouble of any kind.

The box car, which is 38 ft. 6 ins. long over the bumpers, is made with ordinary doors opposite each other in the sides of the car, and these doors are 6 ft. 1 in. wide by 8 ft. 4½ ins. high.

box car side doors butt up to a removable post in the middle. This arrangement is made so that only the ordinary box car door will be used unless the car is to carry a motor car.

The plan of the wide automobile doors is shown in the sketch, and the diagonal arrangement is at once apparent. Two road machines can, if necessary, be carried in one car. The floor of the car is 42¾ ins. from the top of the rail, and the car is 8 ft. 4 ins. wide and 36 ft. long inside. This gives a floor area of 300 sq. ft. The car has a tare weight of about 45,000 lbs. and a marked capacity of 100,000 lbs.

The side sills of the car are made of what are practically Z-bars, and these are faced on the outer side by wooden stringers about 5x4 ins., which are the end supports of the floor planks. The center sills are made of two pressed steel shapes of the channel form, reinforced with an angle along the lower

swings the back edge of the door out clear of the side, and the front end follows along an inclined guide or track, as the door is backed out and away, so as to give a full opening. The motion of the back edge, first out and then along the slide on which it rests,

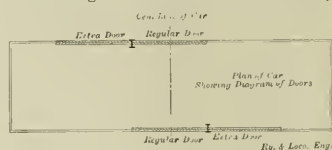

POSITION OF DOORS FOR LOADING AUTOMOBILES.

is accomplished by reason of the fact that the door lever bar is cranked.

The front edge of the door butts up against a post which has been so designed that it can be removed when an automobile has been presented for shipment. This post is made of an I-bar of

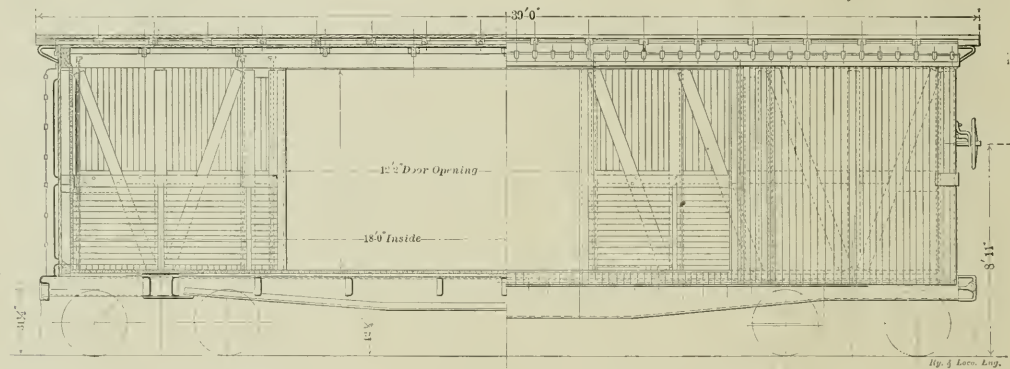

PENNSYLVANIA BOX CAR FOR THE TRANSPORTATION OF AUTOMOBILES.

The car as it stands can be used for freight in the usual way, but when it comes to automobiles the Pennsylvania box car opens a second door in either side and thus gives a total door opening per side of 12 ft. 2 ins. wide by 8 ft. 4½ ins. high. The large opening is got by removing a temporary center post

edge. The ends are 10 ins. deep, and the lower flange is sloped down to a depth of 17 ins. for a distance of about 12 ft. in the center of the car. The body bolsters are also made of pressed steel shapes placed with backs 11½ ins. apart, and the side and center sills are held rigidly together by a series of

steel 5x9 ins. and weighing 75 lbs. The ends are placed in suitable sockets, top and bottom, and the bar is fastened in this position. The flush door when in place can be securely locked, as the back edge butts up closely against the door post and is in line with the car side, while the front edge slips in under the outer flange of the temporary door post, which, by the way, is a very permanent thing, as any one outside would find if he attempted to remove it while the doors were locked.

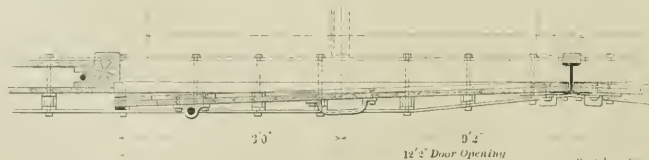

DOOR DETAILS ON PENNSYLVANIA BOX CAR.

where the two doors met, and by running them back from each other along the sides of the car. In fact, the doors are arranged very much like the sliding doors in a dwelling house which are used to separate parlor from dining room, but with this difference, that the house doors meet in the center and the

seven pressed steel diaphragms on each side.

The details of the side door construction are interesting. The door is of what is called the flush style; that is, when shut, it and the car side form one unbroken plane, and when the door is to be opened, a turn of the handle

### One Gone, Another Comes.

Our stock of "Stories of the Railroad," by John A. Hill, is now entirely exhausted and the book is out of print. It will therefore be impossible for us to fill orders for this popular collection. Those of our readers who are fond of pleasant reading connected with railroad life will do well to read "The Last Spike," by Cy. Warman. This book contains nearly a score of short stories and is just off the press. It is sold for \$1.25.

# Our Correspondence School.

In this department we propose giving the information that will enable trainmen to pass the examinations they are subjected to before being promoted. If any of our students fail to understand any part of the instructions, we will gladly try to make them plainer if they write to us. All letters intended for Our Correspondence School ought to be addressed to Department E.

## Self-Taught Men.

Out of the school of experience there has come to some men the knowledge that keen observation can be crystallized into instinct. In no sphere of human endeavor is this more true than that of locomotive firemen. Locomotive engineers readily observe that some firemen keep up steam and make less smoke than others. Such men will generally be found to be largely self-taught. The devices for consuming smoke have been nearly as thick a crop as car couplers or non-refillable bottles, and the cry is still they come. If the same pains had been taken to prevent the formation of smoke as there has been taken to consume smoke after it has been formed some real progress might have been made. As it is, it is within the range of possibility to gather the wisdom of men who, observing the phenomena of combustion, and aiding nature in her subtle workings, have shown that human intelligence surpasses the mechanical contrivances of the inventor.

Last month our correspondence school department was largely devoted to remarks on the proper method of firing a locomotive. The attentive reader could gather in a few sentences what it would take as many years to learn by the mere mechanical routine of the working day. In the lessons this month we offer the same condensation of experience regarding the electric headlight, and it is placed as briefly as need be for the intelligent reader.

## Electric Headlight Questions and Answers.

We have received so many requests for the publication of the answers to the questions on electric headlights that we will pass the general questions of the second series and give questions and answers on the electric headlight, which belong to the third series, as follows:

1. In preparing the electric headlight for service, what would be the first duties of the engineer?

A.—See that bearings have oil, that lamp has sufficient carbon and that commutator is clean.

2. How would you start dynamo to electric headlight?

A.—Slowly.

3. How would you operate throttle to dynamo?

A.—Wide open.

4. Would there be any danger in opening the throttle quickly?

A.—No danger, but not best to do so.

5. How much oil is it necessary to have in cellar to bearings?

A.—Enough for ring No. 22 to touch.

6. What kind of oil should be used in these bearings?

A.—Valve oil outside and engine oil inside bearing.

7. What should the commutator be cleaned with?

A.—Waste, damp first, then dry.

8. How often should commutator be cleaned?

A.—Every trip.

9. How should the brushes bear against the commutator?

A.—With a good bearing with only enough pressure to keep them from sparking.

10. With the old style brush holder is there more danger of sparking at commutator than with the improved brush holders?

A.—Yes.

11. Should the mica be kept below the commutator bars?

A.—Yes.

12. How far should the mica be maintained below the surface of the commutator bars?

A.—About  $1/64$  in.

13. Should sand paper ever be used on commutator?

A.—Yes, when commutator is rough or out of round.

14. How should commutator be cleaned after using sand paper on same?

A.—Between the copper strips to remove any foreign substance that may have lodged there.

15. What precaution should be taken when applying the carbon?

A.—See that they fall freely through clutch No. 44 and carbon holder is on guide.

16. Is it necessary that copper brush attached to carbon clamp bear lightly against guide to upper carbon holder?

A.—Yes.

17. What should always be noted after a new carbon has been applied?

A.—See question No. 15.

18. If the carbon does not raise up when pushing down on this lever what is the reason?

A.—Carbon is not in clutch No. 44.

19. If the carbon is in clutch and does not fall down freely what should be done?

A.—Change carbon or trim round until it does.

20. How long should a carbon burn?

A.—Eight to nine hours.

21. If the carbon continues to burn

up on much shorter time, what may be the trouble?

A.—Speed too high or too much draft in case.

22. Is there another reason why carbon will burn more rapidly than it should?

A.—No.

23. What are the duties of the tension spring on the lamp?

A.—To pull carbons together.

24. What is the correct adjustment of the tension spring?

A.—As loose as possible and not break the arc when locomotive is standing.

25. If you should have this tension spring adjusted too tight what would be the result?

A.—Current would become heavy and the light dull.

26. Could you adjust this spring with too light a tension?

A.—Yes.

27. Why is it necessary that the point of electrode should be cleaned and free from scale before starting out on a trip?

A.—To allow carbon and copper electrode to touch each other as scale is a non-conductor.

28. If this scale was not cleaned off would the light burn?

A.—No.

29. What determines the amount of electrical pressure of voltage of this device?

A.—Speed.

30. What is voltage?

A.—Pressure.

31. If the voltage or electrical pressure becomes too great what damage might be done to the copper electrode?

A.—It would "fuse."

32. What are the indications shown when the copper electrode is fusing?

A.—Green light.

33. What should be done by the engineer when a green shaft of light is seen?

A.—Throttle steam at once and report at end of trip.

34. When the light goes out what is the first thing the engineer should do?

A.—Turn off steam.

35. What great damage could be done the armature and field coils if the steam was not shut off, to the turbine, and it should be allowed to run for some considerable time when the light was not burning?

A.—Might overheat them and burn off insulation.

36. When there is a short circuit how may it be made known to the engineer?

A.—By turbine running very slow, laboring hard and only a red light at carbons.

37. Where are short circuits most likely to occur?

A.—In incandescent wires.

38. How may an engineer know by the operation of this device when the light fails, due to the circuit being broken?

A.—Turbine will be running fast with light exhaust and can get no current.

39. What is one of the most essential things in regard to this light?

A.—Cleanliness.

40. How can this light be focused?

A.—See page No. 10 in Instruction Book.

### Calculations for Railway Men.

BY FRED H. COLVIN.

The amount of water in a boiler is always an interesting question and one which is sometimes rather surprising in its results. It involves quite a few calculations, but they are all easily made and will make us more familiar with finding the area and surfaces of objects in general.

Let us take the boiler of an Atlantic type passenger engine built for the Wabash last year, in which the boiler was 68 ins. in diameter and had 325 tubes, each 2 ins. in diameter (outside) and 16 ft. 4 ins. long. This gives us an actual engine and makes it more interesting than as though we assumed an imaginary case.

First find the amount of water displaced by one tube. This means multiply 2 by itself and get 4 ins. Multiply this by .7854, and we find that the area of a 2-in. tube is 3.1416 sq. ins. Call 16 ft. 192 ins., add 4 ins., so that it becomes 196 ins. as the length of the tube. Multiply this by 3.1416, and we have 615.7536 cu. ins. as the volume of the space occupied by one tube. Drop the last two decimals and multiply this by the number of tubes, which is 325. This gives 200,118.75 cu. ins., and to get this down to cubic feet we divide by 1,728, the number of cubic inches to the foot. This gives 115.69 cu. ft., and to make up for the decimals we dropped before we are perfectly safe in adding to this and making it an even 115.7 cu. ft. This is the space occupied by the tubes and must be deducted from the amount of water that would be in the boiler if no tubes were there.

Calling the boiler, for the present, 68 ins. in diameter and 196 ins. long, we multiply 68 by itself, giving 4,624, and multiplying by .7854 gives 3,631.6896. This could have been done by reducing the dimensions to feet, and might save a few figures. In that case the diameter becomes 5.666 ft., and 16.333 ft. long.

The result would be the same except for possibly a slight difference in the decimals.

Dividing the area by 144 gives us square feet, and this will be easier to handle on account of being smaller, and amounts to 25.22 sq. ft. Multiply this by 16,333, or 16½, and we have 411.92 cu. ft. in the boiler if none of the space was occupied by tubes. Taking 115.7 from 411.92, we have 296.22 cu. ft. left for water.

If this was filled with water clear to the top, we would multiply this by 7½, because there are 7½ gallons to the cubic foot.

But the water does not go clear to the top of the boiler, or there would be no room for steam, and we will assume that the water does not go within 13 ins. of the top. How much does this take out of the water in the boiler?

The easiest way is to consult a good table of segments, as it saves you a lot of figuring that may get you somewhat mixed or be a little discouraging, and if these tables are in a standard book like Kleinhans' "Boiler Construction" or any of the good pocket books, you can rely on them. In fact, it is a good plan to learn how to use tables. To use the tables, first divide the height of the segment by the diameter of the boiler, which in this case gives us 15 ins. by 68 or .22. Looking in the table under the column marked  $\frac{h}{d}$  we find, opposite .22, the number .128114. This is just a multiplier.

Square the diameter, and we have 68 times 68, or 4,624, and multiply this by the multiplier given. This gives as a result 592.4 sq. ins. as area of segment, and dividing by 144 gives 4.11 sq. ft. Multiply this by 16½, the length of the boiler, or this part of it, and we have the steam space, which is 67.13 cu. ft. Subtracting this from 296.22, 229.09 cu. ft. for water around the tubes.

The number of gallons will equal 229.09 times 7½, or 1,718.17 gallons. This will weigh 8¼ lbs. to the gallon at about 40 degs. F. and slightly less at higher temperatures. Calling the water cold, it will weigh 14,321.42 lbs., or over 7 tons.

It is not easy to calculate the water in the back end of the boiler, owing to the varying shape of the crown sheets and the difference in water spaces, although this can be done if we have drawings of the engines to work from, but in this case we will assume the fire box to be 108 ins. or 9 ft. long and that there is one-third the amount of water over the crown and down the sides as there is ahead of the flue sheet in this same length.

This would give us one-third of 181, or 6 sq. ft., for each foot of length, which, multiplied by 9, gives 54 cu. ft. of water over the crown sheet. The

18.1 was obtained by dividing the cubic feet in the boiler ahead of the flue sheet by the length, so as to get the length per foot, and as this was 296.22, it gave 18.1 when divided by 16½.

The extra water over the crown sheet will then be 54 times 7½, or 405 gallons or 3,375 lbs. of water, making a total of 2,123.17 gallons or 17,696.42 lbs. for the total weight of water in the boiler, nearly 9 tons in all.

In the same way, only a great deal more simple, is the finding of the amount of water a tank can carry, unless it has more angles and corners than usual. Reversing the operation, we can see how the designer has to meet this question by considering that a tank had been ordered to hold 7,000 gallons of water.

The first thing is to find out how many cubic feet of space this will require. As a gallon is 231 cu. ins., we divide 1,728 by 231 and find, as we assumed before, that there are 7½ gallons to the cubic foot; we divide 7,000 by 7½ and find that there must be 933.33 cu. ft., which must be found in the best manner possible.

If the water space is 4 ft. deep, it must cover a surface of 233.33 sq. ft. Making it 5 ft. deep, the surface need only be 186.66 sq. ft. Calling the tank 10 ft. wide, the tank would have to be 18.66 ft. long, without allowing any room for coal or other space. The average tender is perhaps 25 ft. long, so that we see it is not a hard matter to get in the 7,000 gallons and a good supply of coal.

## Questions Answered

(25) C. B. C., of Harrisburg, Pa., writes:

Referring to the W. A. B. Co.'s equipment, nicely illustrated in the February number of RAILWAY AND LOCOMOTIVE ENGINEERING, I would like to ask a few questions. 1. Why is it necessary to lap the automatic brake valve on the second engine in double heading, with cut out cock below brake valve closed? A.—So as to close the direct exhaust port from the application chamber of the distributing valve. This exhaust port is piped to the automatic brake valve by way of the independent brake valve, and is open to the atmosphere when the handle of the automatic brake valve is in running position, but closed in all other positions. If this direct exhaust port were left open in double heading, the brakes on the second engine could not be properly applied by the leading engineer.

2. Does lap position of the automatic brake valve have any effect on the ex-

cess pressure top of the pump governor? A.—Yes, it cuts it out, and places the control of the pump under the main reservoir pressure top.

3. Would the engineer on first engine in double heading have any trouble to get the emergency application on the cars through the second engine, there being no quick action triples? A.—Unless the piping on both engines was excessively crooked, no trouble in getting quick action on the train would be experienced.

4. Can the engine and tender brakes be applied with the automatic brake valve while the independent brake valve is on lap position? A.—Yes, the same as when the independent brake valve is in running position, where it should be carried unless in actual use.

#### BROKEN LIFTING ARM.

(26) C. A. H., Kalamazoo, Mich., writes:

Is it necessary to disconnect in case of a broken lifting arm on an eight-wheeled engine? A.—No. Place the lever in a notch in the quadrant where you are reasonably certain that you can start the train, then get underneath the engine and raise the disconnected link until it is about level with the other side, then put in a block of wood that will carry it there. At the same time cut another block big enough to hold the link clear up in case you want to back up at any time.

#### WHERE IS THE DEAD CENTER?

(27) R. J. Y., Needles, Cal., writes: On an engine with cylinders set above the center line of the wheel, is the engine on dead center when the main pin, the center of the main wheel, and the center of cross head are in line? Or is engine on dead center when the centers of all pins and all wheel centers are in line? A.—The engine is on the dead center when the main pin, the center of the main wheel and the center of the cylinder are in line. The dead center cannot be found by merely looking at it. The best method of ascertaining the dead center, or point where the piston stands still is to turn the crank somewhere above the center line of the engine and mark a line upon the outer rim of the main wheel by a trammel the other end of which is placed at some fixed point on the guide yoke or other stationary part of the engine, also mark the position of the crosshead in a similar way. Now turn the crank over the center until the mark on the cross-head coincides, and then with the trammel make another mark on the rim of the wheel. The point between these two marks in the rim will be the dead center, and when the engine is moved exactly to this position with the trammel agreeing at both points, the engine will

be on the dead center on one side. The other side can be similarly located.

#### FROZEN RADIATOR.

(28) F. J. B. writes:

We had a coach equipped with direct steam system, car was run on nearly level track, pipes had proper incline toward trap, trap O. K., 2 in. radiator pipes froze. Why was this? A.—It is possible to have radiator pipes freeze in a car if the admission valve has a defective seat, or if the valve is open very slightly, for in either case a small amount of steam will pass through and the water of condensation is, in severe weather, liable to freeze before it reaches the trap. The steam in condensing sometimes creates a vacuum sufficient to hold the water in the pipes, and at some distance away from the trap. If standing it frequently happens that the car is so placed that the necessary incline of the pipes is neutralized or overcome, and this forms a water pocket. Manufacturers of steam heating systems

the piston travel is 4 ins. or 10 ins., since the distributing valve automatically maintains the proper cylinder pressure in the driver, engine truck, and tender brake cylinders regardless of what the piston travel may be. Hence difference in piston travel with this equipment has no effect on the tendency to slide the wheels.

#### SERVICE DISCHARGE

(30) R. L. C., San Francisco, Cal., writes:

A train of seven and sometimes more cars was switching around the yard. The engineer, of course, was using the throttle, lever and brake valve (*F6*) continuously. In slowing down for a switch he made a service application. The train slowed up, and then the engineer got a signal to keep on going. He had reduced about 15 lbs. pressure from the little drum, and the service discharge was blowing. Upon getting the signal to proceed, he released the brakes by placing the handle in running position. He

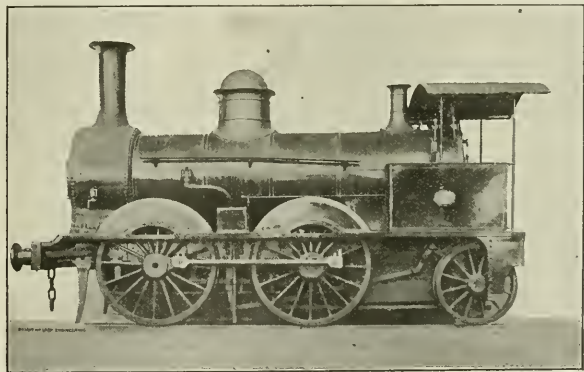

AN AUSTRALIAN OF LONG AGO.

generally insist that the steam admission valves must be either wide open or tightly closed and never partly open. When valve is closed tight no steam or water can get into the coils, and when the valve is opened wide, the pressure of steam forces the water of condensation out of the coils and through the trap.

#### PISTON TRAVEL

(29) J. C. H., Moose, Kan., writes: Would you kindly answer through the columns of your paper whether in braking a train a four-inch or an eight-inch piston travel is the most likely to cause the driving wheels to skid? A.—With the standard engine equipment a four-inch driver brake piston travel, all other conditions being equal, will have a greater tendency to slide the drivers than an eight-inch piston travel.

With the new improved engine and tender equipment, known as the ET, there is no difference in the pressure obtained in the brake cylinder, whether

did not bring it to full release, and the train pipe discharge had not stopped when the handle was placed in running position. Now, after the handle had been placed in running position for at least 5 to 8 seconds the service discharge blow stopped. Why did the service discharge not stop immediately when the valve handle was placed in running position? A.—Operating the brake valve according to the method explained, main reservoir air could flow into the brake pipe only at the rate which the *F6* feed valve would permit, which is considerably slower than when coming from the main reservoir direct, and would then have to pass around the equalizing discharge piston to charge chamber *D*. On this account the increase in brake pipe pressure, with handle in running position and seven or eight cars attached to the engine, could be but very slow, and, therefore, the necessary preponderance of pressure on the upper side of the equalizing discharge piston sufficient to

seat it would be some little time accumulating, tending to make a slow closure of the brake pipe service discharge. If the piston were dirty or the friction of the packing ring somewhat excessive, the tendency further to delay closing the brake pipe exhaust would be increased.

#### Railway Progress in New South Wales.

Our illustrations show in a graphic manner the progress made in New South Wales railway development in the last half century. The train of 1855, with its lightly built engine and its string of six small compartment cars, contrasts strikingly with the far heavier vestibule train of 1905, pulled by a modern 4-6-0 engine.

The distance which the photographer of these two trains has had to move back, after taking the one of the pioneer days in order to secure the same sized negative of the more modern equipment is apparent in the picture, and it helps to illustrate the greater length, and, consequently, the greater weight and capacity of the representative train of today.

The engine which is shown at the head of the first train was one of four originally brought from England. Its cylinders are 16x24 ins., with inside position. It carried a boiler pressure of 120 lbs., and developed a tractive effort of about 8,037 lbs. It weighed in all 33½ tons. The boiler had a heating surface of 1,347 sq. ft., and the grate area was in the neighborhood of 17 sq. ft. The engines of which this is a type did good service in former days, and old No. 1, a still earlier engine, has now an hon-

orifices. The boiler pressure is 160 lbs. to the square inch.

The carriages used when the railroads were in their infancy were short four-wheel compartment vehicles with side doors. The second-class ones measured 18 ft. 4 ins. by 6 ft. 8 ins. by 5 ft. 9 ins. high, giving a floor area of 3.6 sq. ft., and 23½ cu. ft. of air space per passenger. The com-

of RAILWAY AND LOCOMOTIVE ENGINEERING, has for some years been chairman of the government commission concerned in the management of the railways of Australia. The success which has been achieved on the steam transportation highways of the island continent is largely due to the wise policy and able administration of Mr. Tait. A great national asset is being steadily built up, of



NEW SOUTH WALES TRAIN IN 1855.

modious carriages now used are mounted on six-wheel bogies. They have end doors and will comfortably seat 60 passengers. They measure 43 ft. 3 ins. by 8 ft. 1 in. by 8 ft. 5 ins. high. Each passenger has 47.7 cu. ft. of air space and a floor area of 5.9 sq. ft.

The improvements which are apparent by a comparison of the early and the latter day trains is indicative of the progress which has been made in other departments, though, perhaps, the locomotive and carriage department is able to

which the government and people of the commonwealth may well feel proud.

On receiving a neat little souvenir the other day in the shape of a desk calendar, we were reminded of the author who said to his publisher, "I suppose I can get my book bound in Morocco?" "No sir," replied the other, "you will get it bound in America, where I make my money!" The desk calendar, however, has been made in America and is bound in Morocco, and will be found to be a neat and useful desk accessory in any country. It is being sent out by the Flannery Bolt Company, of Pittsburgh, Pa., to their friends. It stands about 5½ ins. high and is good for more than one year, as cards can at any time be procured which will fit the case. We do not know for certain if this concern, which are the makers of the Tate Flexible Staybolt, intend the desk calendar for general distribution, but it is worth asking for. Drop the company a post card if you require a desk calendar or some flexible staybolts, and say we advised you to make the attempt.



PRESENT DAY TRAIN, NEW SOUTH WALES RAILWAYS.

ored place in the museum of the Technical College at Sydney, N. S. W. These engines cost each when new about £3,000.

The modern ten-wheel machine weighs about 70½ tons, and cost £5,305. The cylinders are 20x26 ins., and it is capable of exerting a starting effort of 22,187 lbs. The heating surface is 1,916 sq. ft., and the grate area is 27 sq.

furnish the most striking example of progress. The buildings and bridges have grown in size and strength with the growth of the railways, and the science of train operation has kept pace with augmented traffic and increased earning power.

Mr. Thomas Tait, formerly manager of transportation on the Canadian Pacific Railway, and an old and valued friend

The Standard Car Truck Company, of Chicago, during the year 1905 took large orders for their roller motion trucks. The number of cars so equipped, having a capacity ranging from 60,000 to 125,000 lbs., was 56,683, and 879 locomotive tenders were supplied with these trucks in the same time. Thus 115,124 roller motion trucks were turned out by this company last year.

# Air Brake Department.

CONDUCTED BY J. P. KELLY.

## The Westinghouse "K" Feed Valve.

The improved feed valve shown in the illustrations, Figs. 1 and 2, is the latest, and the one now being supplied with the new ET engine and tender equipment.

Its inner construction is easily understood from the drawings, which are diagrammatic views of the valve in the open and the closed positions.

Its operation is as follows: Main reservoir air enters at the connection marked "MR," passes through port *a* into chamber *B*, between the heads of the differential piston 5; then through

19 is in the position shown in Fig. 1. While the slide valve 8 is in "open position," supplying air to the brake pipe, the pressure in passages *e*, *d*, *k* and in chamber *I* will be the same in amount up to the point for which the feed valve is adjusted.

When the pressure in chamber *E* over the diaphragm 16 and regulating spring surrounding diaphragm spindle 19, reaches the limit of adjustment it will compress the regulating spring and force the diaphragm spindle 19 to the right far enough to press against the guide stem of vent valve 28, and unseat this valve.

venting further increase of pressure in the latter.

When the diaphragm 16 and the diaphragm spindle 19 are forced to the right, in the manner described, the small valve 14, previously held from its seat, permitting communication between chambers *E* and *G* and the brake pipe, seats, and cuts off this communication.

As soon as brake pipe pressure falls below the limit of adjustment, the diaphragm 16 and the diaphragm spindle 19 move to the left, unseating valve 14 and permitting the air in chamber *G* to flow through passage *f* and chamber *E* to the brake pipe, and seating valve 28, permitting pressure to accumulate behind the larger head of the differential piston. Then piston 5 moves quickly to the left, and opens the feed port *d* to the brake pipe.

The regulating spring is a short one, and the regulating nut has a handle fitted to it so that when this handle is against the stop 23, which is mounted on the spring case, the feed valve will maintain 70 pounds pressure in the brake pipe; when the handle is moved around to the stop 24 the feed valve will maintain 110 pounds brake pipe pressure. By changing the location of the stops any intermediate brake pipe pressure between 70 and 110 pounds may be had.

Because of the quick and simple method of changing from one pressure to another, as required by the kind of service in which the locomotive is employed, but one feed valve of this type, used in conjunction with the improved pump governor, is necessary on any engine, passenger, freight or switcher. Hence, in changing from the low pressure to the high pressure control, or the high speed brake, it is only necessary to change the position of this regulating handle from one stop to the other.

### Correction.

Referring to our description of the ET equipment, February number, page 75, near bottom of second column. We said that the branch in the return pipe, having the K feed valve in it, was connected to a port in the automatic brake valve so controlled by the rotary as to supply air to the brake pipe in running position only. This should have read "running and holding positions only."

At the bottom of page 76, same arti-

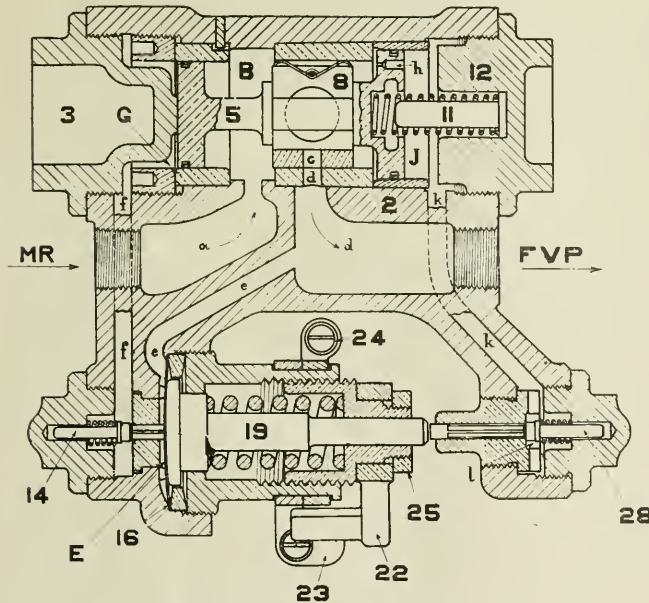

WESTINGHOUSE "K" FEED VALVE, OPEN POSITION.

port *c*, in the slide valve 8, to port *d* in its seat and to the connection marked FVP, the feed valve pipe, which goes to the brake valve and through passage *e* to chamber *E* and the diaphragm 16; then past valve 14 to passage *f* and chamber *G*, behind the smaller head of the differential piston.

At the same time, the air also passes through port *h* in the larger head of the differential piston into chamber *J*, and on through passage *k* to chamber *I*, in which the small vent valve 28 is located. The air and spring pressure hold valve 28 to its seat while diaphragm spindle

When valve 28 unseats, the air in chamber *I*, passage *k*, and chamber *J*, will escape to the atmosphere, thus quickly reducing the pressure behind the larger head of the differential piston.

With the pressure thus reduced in chamber *J*, main reservoir pressure, in chamber *B*, assisted by brake-pipe pressure in chamber *G*, will force the differential piston 5 and the slide valve 8, which is caught between the shoulders on the valve stem connecting the piston heads, to the right quickly and close the communication between the main reservoir and the brake pipe, thus pre-

cle, with reference to the double cut-out cock. It was stated that when this cock was turned to cut out the brake valve it opened communication between the distributing valve and the independent brake valve, etc. It should have said, "opens communication between the exhaust port of the application chamber of the distributing valve and the atmosphere by way of the automatic brake valve."

#### The Air Pump Strainer.

On one of our leading eastern trunk lines frequent reports came into the roundhouse that the air pump would not pump a sufficient amount of air to supply the train, and upon one occasion a pump was condemned and changed, although there was no apparent reason for condemning the pump, other than it would not supply enough air.

Following this instance another of the same nature occurred, in which it was found, that the strainer was at fault, it being almost entirely plugged.

These instances woke me up to the fact that a plugged strainer is a serious defect, in that if a pump cannot get air, it certainly cannot compress air; hence we have no air at all or only a meager supply for the air brake system.

I find it very profitable to myself and all concerned to keep pump strainers free from all dirt, and especially valve oil. Since the strainer is for the purpose of excluding all foreign matter, and to freely admit air, the air cylinder should never be oiled through it, but through the oil cup which is provided for that purpose.

A very effective and speedy manner of cleaning strainers is to blow steam through them; the steam loosens any crust formation due to dust, etc., and also increases the temperature of any valve oil that may have been wrongfully poured over the strainer, so it will run freely.

Any air brakeman who will keep the air pump strainer clean and the meshes open and the pump in good repair generally, by well lubricating it and tightening all leakages of both steam and air, will save himself much unnecessary work and trouble, and will also save the railroad company, that employs him, many pump failures and consequently engine failures, which will surely be appreciated by them.

WIRT D. SEELEY,  
A. B. Repairman, N. Y. C. Roundhouse.  
East Buffalo, N. Y.

#### Emergency Due to Difference in Graduating Springs.

Editor:

In the January number of RAILWAY AND LOCOMOTIVE ENGINEERING there appears an article entitled "Testing High Speed Brakes," in which the author refers to the undesired quick action.

While we cannot attach too much importance to the condition of the equalizing piston, air gauge, condition of equalizing reservoir connections, the train line exhaust fitting, and lubrication for triple valves, there is one point that may have been overlooked in our search for the cause of emergency with service application.

In the F-36 triple valve there is a graduating spring of 49/1000-in. wire, 16 coils, 2 $\frac{3}{4}$  ins. length, and 29/64 in. inside diameter, which is considered strong enough in freight service with the longer train and larger pipe.

In the passenger service, we are told,

springs in the F-27 and F-29 triple valves back in the train.

It cannot be disputed that the F-36 triple valve will work perfectly if it and the brake valve are in good condition; but the fact cannot be used as an argument in its favor, as it is possible to make an equalizing piston so sensitive that the brake on an engine alone will work in the service application with the graduating spring in the quick action triple valve, on the tender, removed.

When the F-36 triple valve is used with the high speed equipment, there is no doubt that slight brake valve dis-

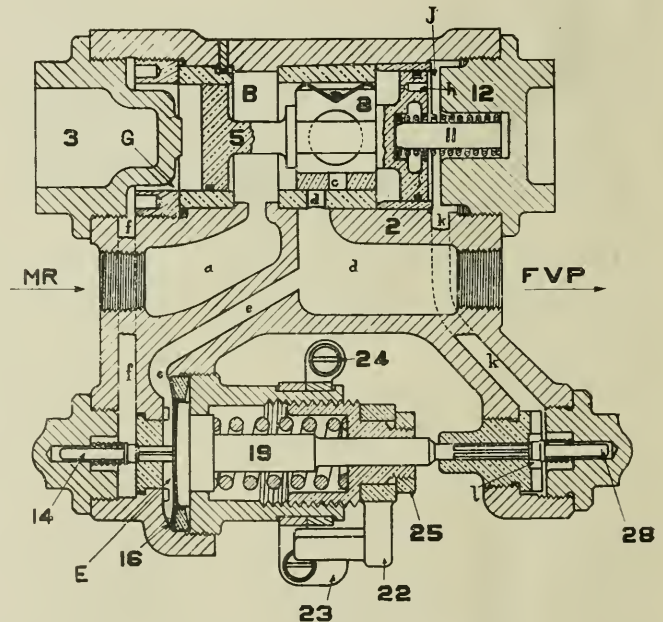

WESTINGHOUSE "K" FEED VALVE, CLOSED POSITION.

we require a stronger spring, owing to a shorter train pipe, and on account of the triple pistons moving faster, more resistance is required to stop them in the service position, and a spring of 8/1000-in. wire, 13 $\frac{3}{4}$  coils, 2 $\frac{5}{8}$  ins. length, and 29/64 in. inside diameter, is used.

Yet when a locomotive tender is equipped with an 8-in. brake cylinder in the high speed service, an F-36 triple valve is used, and as it is nearest the engine, it is consequently the first to be affected by slight disorders of the brake valve, tending to cause undesired quick action. The 110-lb. train pipe pressure creates no tendency to move the triple pistons slower or make them move more smoothly, yet the weaker spring in this triple valve is expected to offer as much resistance to this higher air pressure as the heavier

orders and leaky train pipes will throw this triple valve into quick action with service application, where, if the 10-in. equipment were used on the tender, quick action would not have occurred. As we cannot use the F-27 triple valve with the 8-in. tender brake apparatus, let us have a heavier graduating spring for the F-36 when used in the high speed service, say one of 13 or 14 coils, and about 65/1000 in. in diameter.

G. W. KIELNN,  
Washington, D. C. A. B. Mach't, Penna.

[Experience with undesired quick action, with which the article our correspondent refers to deals, does not indicate that it is caused by the quick action triple on the tender, as when the engine is cut away from the train the brakes may be applied in service without causing undesired quick action, using a brake pipe pressure of 110 lbs.



The undesired quick action or emergency which is annoying is that had on long trains which are made up principally of cars coming in from branch roads and making up the train on the through line. Occasionally these cars have air brake equipment on them overdue for attention and cleaning. Hence it is the condition of the triple, and not its construction, to which particular attention should be directed. It would be unreasonable to expect a triple valve to run as long under a brake pipe pressure of 110 lbs. without attention as formerly, when only 70 lbs. pressure was the maximum used.

The F-36 triple valve has a service port equal in size to that of the F-27, and therefore is equipped with the lighter graduating spring.—Ed.]

**Straight Air and Automatic on Grades.**

*Editor:*

Looking over the cause of the most of the break-in-twos, I desire to call your attention to a few points about the straight air brake, etc.

In making a stop with a train while ascending a grade, even if the grade be very slight, if the stop is made with the straight air brake or by just shutting off the steam, the automatic brakes should be set at once or just a second before the train comes to a stop; this is done to keep the slack of the train from running back and doing damage to the cars. The automatic brake should be held set until brakeman has had time to set enough hand brakes to hold the rear end of train, if it is intended to meet a train or remain some length of time.

The same holds good when on the mountain with helpers in the train. Although the rear helper man must work steam until after the train comes to a stop, he must not be relied upon to hold the train after the stop is made. Example: If ascending a mountain the stop is made by shutting off steam or by use of the straight air brake, just at the moment of the stop a heavy application of the automatic brakes should be made, not less than ten or twelve pounds, and held as above.

In making a stop with a train, if the engine be equipped with the straight air brake there will be less danger of damage if the automatic air brakes are well set first, and just before coming to a stand, the straight air brake set. Doing this way the train is bunched slowly, when the steam is shut off, and application of train brakes made; where, if the straight air be set first, there is always some danger of the rear end of train running up against the engine with more or less damage to cars. If it is the intention to make the stop with the straight air brake alone, great care must be exercised making very slight applica-

tion, with intervals between to allow the slack to run up. When handling trains on the grade the straight air brake should not be used unless it is necessary.

Example: Holding a train down the mountain with only the automatic brakes set, you release the brakes; if after doing so you find there is no jerk to the engine, you should not use the straight air brake with that train when releasing. If after releasing you feel a jerk to the engine by the train, thereafter you should set the straight air brake enough to hold the engine against the train, and then release the automatic brakes.

When you first release the brakes you should not leave the straight air set, to find how your train bunches.

C. R. PETRIE.

**Air Brake Cannon.**

*Editor:*

I have recently gotten up a little device for removing the air piston off of the rod of 8-in. and 9½-in. air pumps, when stripping pump for overhauling. For a long time I used various screw devices, all of which were more or less unsatisfactory. So I decided to shoot them off, and here is a rough sketch of the gun I use.

Just a common block of machine

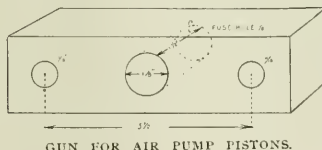

steel, 2½x2½x7¼ ins. long; 2½ ins. holes, 5½ ins. apart for 2½ in. bolts; hole 1½ ins. diameter and 1½ ins. deep, with fuse hole drilled through in center of block to hole for end of piston rod to slip in. One thimble full of gun powder, with a leather wad, rammed in, and some paper if necessary; bolt block up to air piston, put some powder in fuse hole, heat a rod and touch off. Piston is removed and no threads are burred, only set up a block to keep piston from jumping too far. Have never broken a piston or rod, nor pulled out either of the 2½-in. bolts, and it's quickly and cheaply done.

GEO. C. McDUGAL,  
Air Brake Machinist.

Sanford, Fla.

**Series of Troubles.**

*Editor:*

Years ago I used to think it was impossible for an air brake to fail, but since I have had more experience I find I was wrong. Every once in a while we hear of trains running away on mountain grades, or of rear end collisions due to air not working, etc.

After the wreck the cars that are left are generally taken and tested and found to be O. K. and the engineer generally has to take all the blame. Now it's all right to test the cars, but if the trains were gone over half as carefully before the disaster as they are after there would be less trouble.

But we all have to pay for our experience. I here wish to give a few of the troubles I have had. We all know that air pump strainers will freeze up in zero weather and air pumps cannot make air with it stopped up. I had a train of 60 cars not long ago with orders to pick up five more, picked them up and started. I did not get far before I stalled, and air gauge showed the air pumped up; I went back and found an angle cock turned on the second car; I turned it open, and started again, but the brakes stuck again within a mile, when I found the angle cock turned again. I then tied it open with wire and had no more trouble.

The day has passed when a train crew of two men can stop 55 loads of coal on a down grade. I found that out some time ago when I pitched over a grade and started to apply the brakes. I had a very short train line exhaust, so I applied the emergency at once—I had them going about fifteen miles an hour—and they ran about that speed for the next half mile. I called for brakes five or six times, but meanwhile one of the train crew put down a couple of hand brakes, and the other gave me the high ball. Finding that the air brakes were gradually leaking off, the grade getting heavier and train gaining speed, I got back on train and commenced to set brakes myself, finally getting stopped three miles from the top of the grade. The cause of this was the angle cock turned behind the eighth car, train pipe brace being loose or car allowing the pipe to vibrate and angle cock to hit car sill. Some will say if angle cock turned brakes would stick. I have found this to be a mistake. Sometimes they will apply hard enough to stall train, and at others they will not.

I was stopped by a flag once and held by a work train twenty minutes, and when I tried to stop the train for a draw bridge I found that some boys had turned angle cock some 25 cars back, and the air in the cylinders behind had leaked away while standing so long. Another time I left terminal with short train, some fifteen cars, and at top of mountain I picked up to thirty, and found that I could not pump them up. I could not get any speed on the pump. It would make about fifty strokes a minute and that was all. I went through steam governor, I went through air pump, could find nothing wrong. After that

I sat down on the end of some ties and cussed awhile, thinking what a fool I was that I couldn't locate the trouble with this pump. After I found I could not do any good by cussing, I commenced to hunt for the cause again; this time I found it.

On this class of engines with piston valves they had put a three way cock in air pump exhaust pipe, the object being to turn the air pump exhaust into cylinders while drifting and keep them lubricated. This three way cock was close up under running board, handle was gone, and cock had got turned, almost closing exhaust from air pump. Air hose may freeze up in high altitudes and when cars reach the lower levels thaw out again. I hear some one say, "It certainly won't freeze while you are braking." I know better, as I have had it to do so.

pump strainer close under running board. I laid down and examined suction and found a newspaper up against strainer, cutting off all air. Another case where if damage would have resulted, air on engine and cars would have been found O. K. I understand that the Economy steam heat apparatus has a three way cock in air pump exhaust. I would advise all brother engineers to be careful that these cocks are in good shape. Another trouble I find: it is no use to stick up bulletins how many retainers to turn up; the greatest trouble I find is how are you going to make them do it? BUSTER BROWN.

#### Torque and Power.

The torque of an electric motor is the pounds pull developed at the circumference of a wheel or drum 2 ft. in diameter secured to the armature shaft.

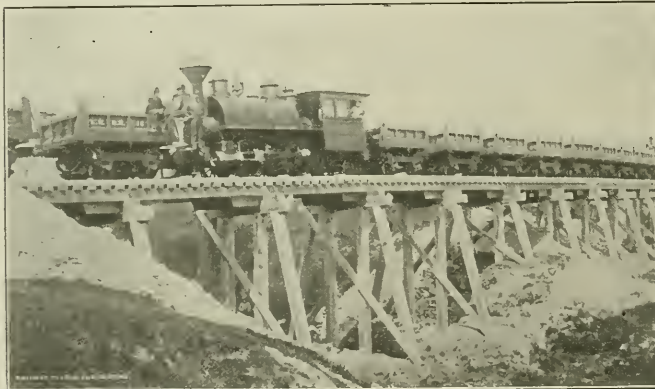

MAKING A FILL. LIME ROCK RAILROAD.

One more, then I quit for the present; I get tired writing. I was running along across a level with some 60 loaded cars; it was night, and just moderately cold. I had the air fully charged up, as shown by gauge. After awhile I noticed that the train line was leaking away from me very slowly at the rate of a couple of pounds a mile. I lapped brake valve and noticed the amount of train line leakage; it was very little. I gave pump a little more steam, no difference. I went out on running board and listened to air pump; it was working a little fast, and as square as a dollar. It was not cold enough for air pump strainer to freeze up. I knew its air inlets were not gummed up. Now, what was the trouble? If I stopped, there was the conductor ready to turn in engine failure; if I went ahead I would meet a flag or hind end. Well, I'll tell you the trouble. On these engines a hole is cut through running board, and the air cylinder of air pump is let half way through; this throws air

It is practically the weight a motor so arranged could pull up out of a well with a rope, and is measured in pounds. Power is the rate of using torque.

"The relation," says a writer in the "Electric Magazine," "may be illustrated by imagining a cable wound round a drum 2 ft. in diameter and used to hoist a load without the use of intermediate pulleys. The tension of the cable corresponds to the torque. If the tension is 330 lbs., and the speed 100 ft. per minute, work is being done at the rate of 33,000 foot pounds per minute, and that is 1 H. P. If the load is stationary, the torque may be the same, but no power is developed. With a given torque, power is proportional to speed, and at a given speed power is proportional to torque."

Elsewhere work has been defined as pressure or pull acting through distance, and power is the rate of doing work. Work is expressed in foot-pounds and power in foot-pounds per minute, or second, as the case may be.

When power is spoken of, the time element is always understood to be present.

#### Gasoline Inspection Car for Railroads.

George H. Webb, chief engineer of the Michigan Central, made an inspection trip early this year over his system with a gasoline car, made especially for railroad work. The data showing what was accomplished with this car are interesting.

The total distance traveled was 4,347 miles, and the total amount of gasoline used was 231 gallons, or an average of 19.7 miles per gallon of gasoline. The records show that on the run from Jackson to Allegan, a distance of 175 miles, round trip, only 7½ gallons of gasoline were used, or 23.3 miles per gallon. The total cost per mile, including lubricating oil, battery cells and everything excepting wages of man in charge, was nine-tenths of a cent.

This gasoline car has its advantages also because of its ability to attain a high speed and maintain it on a long run. The trip from Marshall to Allegan, 66.4 miles, was made in one hour and 40 minutes, or at the rate of 40 miles per hour. The distance from Tekonsha to Harris, 29 miles, was made in 45 minutes, and the best run of the entire trip was made from South Haven to Kalamazoo, a distance of 39.6 miles, in 45 minutes, or at the rate of 52.94 miles per hour.

#### Valley of the Sacramento.

What has been called the empire of the Sacramento valley is inviting the attention of home-seekers, as well as tourists, to a great extent, and the publication at this time of a booklet by the Southern Pacific, descriptive of the region, is opportune. It consists of 112 pages, 5x7, finely illustrated, and it has been brought up to date in a painstaking manner.

In addition to the descriptive portion, the writer, Mr. A. J. Wells, has given valuable chapters on the subjects of "A Great Empire and a Great Opportunity," "Why Is the Valley Not Densely Settled?" "Cash Value of Climate," and "Social Life." A chapter of especial interest at this time, in view of the reclamation work of the State and general government, is that on "The Delta Lands of the Sacramento," illustrated with a map of the region. Tourists will be specially interested in the picturesque scenery of Lake Tahoe, the Sacramento river, and the region of Mount Shasta.

To sum up, the region has been described by a few verses taken from Deuteronomy. They are 7, 8 and 9 of the eighth chapter. The illustrations are excellent, made from photographs specially taken. The book

will be sent to any address by the Southern Pacific, on payment of ten cents. If you desire a copy, write to 431 California street, San Francisco, Cal.

#### M., K. & T. Balanced Compound.

The Missouri, Kansas & Texas Railway System recently secured some passenger power from the Baldwin Locomotive Works. The road is familiarly called by a nick-name, made from its two last initials, and, as the balanced compounds which we illustrate haul fast trains, they may appropriately be called the Katy fliers.

The cylinders are 15 and 25x26 ins., and the diameter of the six driving wheels is 68 ins. The high pressure pistons drive on the leading axle, which is cranked, while the low pressure pistons drive on the outside of the main wheels in

carry equalizers which enable the springs to be placed between the upper and lower frame bars, and between the wheels, all of which are flanged. The connecting and side rods are made in I-section, and the side rods have solid ends. The butt end of the main rod is forked and the brass is secured with keeper and taper key.

The boiler is of the wagon top type. The pressure carried is 220 lbs. The tubes are 2 ins. in diameter and there are 299 of them, each 16 ft. long. This gives a heating surface of 2,493.6 sq. ft. and with the 160 in the fire box gives a total of 2,654.2 sq. ft. The grate area is a little over 28½ sq. ft. The boiler measures 60 ins. at the smoke box end. The second course is the gusset and at its back circumferential seam the boiler is 71 ins. diameter. The roof is level, but the crown sheet slopes up

x10 ins Wheel base—Driving, 13 ft. 6 ins.; total engine, 27 ft. 7 ins.  
Weight—On driving wheels, 123,120 lbs.; on truck, 49,250 lbs.; total engine, 172,370 lbs.  
Tender—Wheels, diameter, 34 ins.; journals, 5½ ins. x10 ins.  
Service—Passenger.

#### Backing Out a Plug.

Red lead is a good thing for certain purposes, but concerning the making of pipe joints, Graphite says: "Never a good practice, and to-day a very bad one, is that of fitting pipes with red lead. Dixon's Graphite Pipe Joint Compound cannot 'set,' will not weld a joint, never allows a bit of a leak or rust in its presence, and makes changes in piping possible without wholesale destruction."

We have found that the best way to keep boiler washout plugs tight and yet easily removable at all times was to

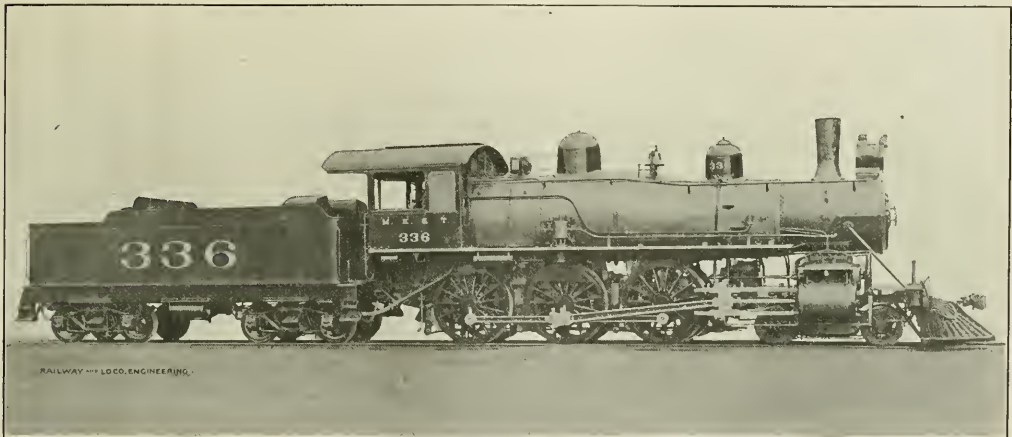

MISSOURI, KANSAS & TEXAS TEN WHEEL ENGINE.

W O'Herin, Superintendent of Machinery and Equipment.

Baldwin Locomotive Works, Builders.

the usual way. The low pressure piston rod is very long on account of the position of the cylinders and the cross-head moves back and forward near the open end of the guides. The high pressure piston rod and guides are made according to the usual practice. The low pressure arrangement is for the purpose of securing a satisfactory position for the cylinders. The main valves are of the piston type 16¼ ins.; it is, therefore, 1¼ ins. larger than the high pressure cylinder in diameter. The valve chamber is placed in the saddle casting above the frame and the valve is actuated by indirect motion, the eccentrics being on the main driving axle. The valve is so arranged that it is outside admission for the high pressure cylinder and inside for the low.

The driving spring arrangement is an overhung spring above the leading pair of drivers and the other driving boxes

2 ins. toward the front. The back sheet is not perpendicular, but leans forward about 22 ins. at the top.

The tender has the usual steel frame, and the tank, which is of U-shaped plan, has a capacity of 6,500 gallons of water and carries 8 tons of coal. The weight of the engine and tender is about 290,000 lbs. Some of the principal dimensions are given below:

Boiler—Thickness of sheets, 11/16 in. and ¾ in.; working pressure, 220 lbs.; fuel, soft coal; staying, radial.

Fire Box—Material, steel; length, 108½ ins.; width, 41¼ ins.; depth, front, 68½ ins.; back, 66½ ins.; thickness of sheets, sides, ¾ in.; back, ¾ in.; crown, ¾ in.; tube, ½ in.; water space, front, 4 ins.; sides, 3½ ins.; back, 3½ ins.; heating surface, 160.6 sq. ft.; tubes, 2,493.6 sq. ft.; total, 2,654.2 sq. ft.; grate area, 28.6 sq. ft.

Driving Wheels—Journals, front, 10 ins. x10½ ins.; other 9 ins. x12 ins. Engine truck wheels—diameter, 30 ins.; journals, 5½ ins.

coat them with tallow and graphite. That was, of course, in the days when tallow could be had on a railway. Graphite was the main thing and the tallow was used simply as a vehicle to hold the graphite, and, by the way, a lot of graphite was wasted getting it "where it would do most good," because after the plug had been coated with tallow, the flake graphite was dusted over it and smeared around the plug. The modern way is to use a compound with the graphite already mixed in.

It is a sad sight to see the "square" of a washout plug wrung off and the plug in as tight as ever, for the next act in the washout drama is generally a resort to a cape chisel and hammer in order to back out a plug which has got the idea that it is part of the boiler. Graphite seems to make a boiler plug understand what is taking place on washout day and act accordingly.

### Science Applied to Car Design.

The dictionary meaning of the word science is knowledge classified and made available in work, life, or the search for truth, and nowhere is science better applied than when it results in the intelligent designing of passenger car details, and the production of

48 persons, the advantageous use of the floor space of the side door car is at once apparent. The seats are arranged back to back, four people being on each "bench" across the car. This arrangement provides a door for the entrance or the exit of every group of eight. The average length of stops on the Illinois

stepping across the gap is thereby increased. It thus appears that the loop which may be considered a good terminal from a train operating standpoint is most objectionable when combined with a station platform, as it then practically debars the road from the use of cars which would greatly reduce the time consumed at stations.

One of the new features, and one which at night would strike an observer of these side door trains, is what appears to be an illuminated door pull on each door. This effect is produced by the light inside the car shining through a glass plate, which forms the partition between the outside and the inside depression for the fingers. The doors have to be opened by the passengers, but they are shut by the guard. Inside the lighted car any sort of a door pull can be seen, but from the outside, the edge for the fingers to catch being situated in the dark solid portion of the

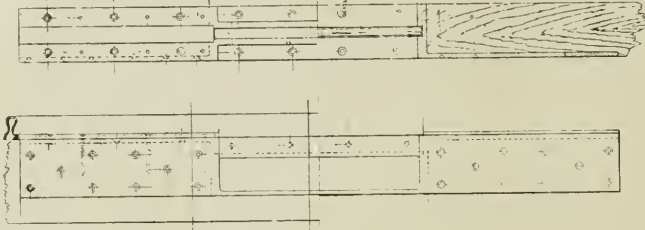

ILLUMINATED DOOR PULL, SULLIVAN SIDE DOOR CAR.

a vehicle in which comfort and utility are happily combined. Such is the Sullivan side door car, used in suburban traffic on the Illinois Central Railroad. The car is too well known to require minute description here, but several new features have been introduced which, though they may appear small to the hurrying public, yet help to swell the sum of details in which classified knowledge has been made available in the work.

This steel frame passenger coach, the design of which has been worked out by Mr. A. W. Sullivan, general manager of the Missouri Pacific, and Mr. Wm. Renshaw, superintendent of machinery of the Illinois Central, is par excellence, the side door car. It

Central suburban trains, with these cars is said to be 7 seconds. The Boston Elevated, with side doors in the center of the car, 17 seconds, and the New York subway, with end door cars, 30 seconds.

When an Illinois Central train draws up at a platform, the whole of one side practically becomes available for entrance and exit, and the time occupied at stations is thus reduced to its very lowest terms. This is a factor of the greatest importance, because on a block signalled line, where quick stops and rapid acceleration has been provided for and where short headway between trains is a rule, the ability to handle the living load at stations becomes practically the capacity limit of the road.

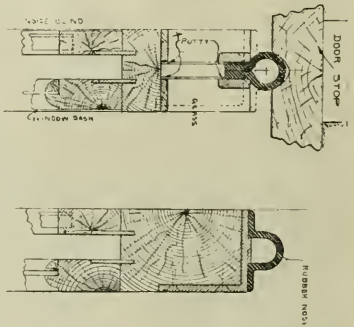

DETAILS OF EDGE OF DOOR AND DOOR STOP.

door actually shine out conspicuously, and no time is lost hunting for the handle. The door pull is 6 ins. long, 1 in. wide and about  $\frac{5}{8}$  in. deep at the side on which the passenger pushes to open the door. As the guard always closes the door, the pull is made with an edge  $\frac{1}{2}$  in. wide for the fingers of anyone who insists on helping the guard.

The door itself, while opened by the passengers and closed by the guard, for reasons which will presently appear, is always locked and unlocked by the guard. The arrangement by which this is done consists of three hand wheels about 20 ins. in diameter, placed near the roof, one on each side at the ends and one in the middle. Any of these wheels is made to operate each its own pinion, which gears into a rack, and so moves a long rod which passes over the car doors, and this rod carries, for each one, a lug, which engages with a bumper fastened to the top of every door. The reason the passengers are compelled to open the doors is for the purpose of saving the unnecessary door opening at any of the sections or com-

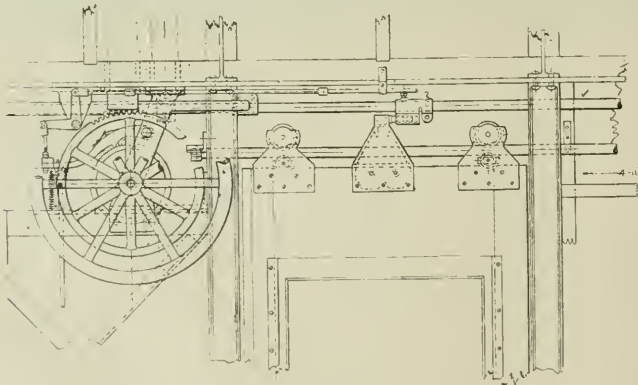

DOOR CLOSING MECHANISM ON ILLINOIS CENTRAL CAR.

has 12 openings on each side, as well as the usual vestibule entrances and end doors. The seats are arranged so that there is an aisle down each side of the car, and there is comfortable accommodation for 100 people. When this is compared with cars which seat only

The objection to the use of the side door car in the New York Subway and other similarly constructed roads is that platforms, beside sharply curved track or at loops, present too great a space at the center or at the ends of the cars, and the danger of accident to passengers

partments where no one gets in or out. The shutting of open doors and the locking of all by the guard is for the purpose of having a positive action made to insure safety. The locking is accomplished very simply, by means of a ratchet and pawl put upon the shaft of the center wheel. The pawl drops by gravity and is raised by levers and rods operated by a treadle, placed near where the guard usually stands. The lock is therefore positive in its action and never misses taking hold.

A very ingenious feature connected with this door is that while it closes tightly enough to exclude drafts of air, rain or drifting snow, it does not come up so violently when being shut as to strike an unyielding blow on any one unfortunate enough to be caught in the

we have just spoken, it may be observed that in the head of what we have called the door-shutting lug, there is a device something like a push button, and this comes in contact with the bumper. It is, in fact, a small, hollow cylinder filled with a spiral spring, and this arrangement takes up any shock which might be caused when the lug and bumper come together. It also enables the door to be pushed back one inch from the stop after the door has been closed and locked. Taken in connection with the rubber nosing on the door edge, it is possible to draw out a portion of one's garment, containing a pocket, if caught between door edge and stop, and to do so even if the pocket had in it a small parcel. In fact, a brake chain might be drawn through with this door closed

ing signal unless every door on the train is closed and locked. The doors are electrically connected, in series, and each car is provided with a few cells of dry battery, the circuit being made by contact of the doors when closed, and broken when they are opened. The wiring and connections, though exceedingly simple, are most effective. The cable ends joining the cars have their ends secured in sockets mounted conveniently beside the air brake hose. The St. Louis Car Co. now have the right to build these cars.

Altogether, the cars have maximum seating capacity, their use has materially reduced station stops, and prevented jostling and crowding of the passengers. The hand door pulls are visible from the outside on the darkest



SUBURBAN SIDE DOOR CAR USED ON THE ILLINOIS CENTRAL.

doorway. In the first place the edge of the door is covered with rubber nosing, made in the form of the letter U, and when the door is shut this beds in a shallow groove in the door stop. There is about half an inch of compression yet left in the rubber, if we may so say, and this is available in case of emergency. For instance, if a passenger had the end of his coat caught between door edge and stop, he could still very easily draw it out after the door had been locked. The bumper on the top of the door, which the door-shutting lug strikes against, is made with a broad base and is placed in the center of the door so that when pressure is applied to it the door moves at once and without tilting or shaking. The hidden edge of the door is covered with plush, which makes it airtight when shut.

As a further aid to the unfortunate passenger with coat caught, of which

and locked if one end of the chain was beyond the edge. The door would close up on each vertical link, yet yield sufficiently to let the horizontal links through. A careless passenger with coat caught in the doorway cannot be held a tight prisoner, but may free himself with but slight exertion.

The ingenious way in which the details of the doors have been worked out have secured a method of operation by which only the doors which are actually required are opened, and when closed they make a yielding though draught proof joint on the stop which does not grip loose clothing. The doors when shut are securely locked so that no one can get in or out, nor can the doors open by accident.

A still further safety feature used on these cars consists of an electrical arrangement whereby it is impossible for any guard on the train to give the start-

night. The doors, while closing tightly, will not grip or permanently hold loose portions of clothing. The doors lock securely and the motorman or engineer cannot be given the signal to start until every single side door throughout the whole train is shut and locked. Thus science, like patience, has had her perfect work.

#### Increase of Pay on the B. & M.

An increase of pay and a reduction in the hours of labor have been given by the Boston & Maine Railroad to its conductors, trainmen and yardmen. The increase in wages amounts to from 10 to 15 per cent. The company makes eleven hours constitute a day's work where twelve was the schedule, and ten where eleven was the rule. The pay of conductors will now be \$3.50; through freight train men, \$2.25; local freight men, \$2.50, and yardmen \$2.40 for day service and \$2.50 for night service.

### Tractive Effort of a Geared Engine.

A correspondent writes asking us to give the rule for calculating the tractive effort of an ordinary simple locomotive, and also that for a geared or Shay locomotive. We have often printed the tractive power rule, but for the benefit of those to whom it is still new, we may say, multiply the diameter of the cylinder in inches by itself, or, in other words, square the diameter of the cylinder and multiply the product by the stroke in inches, multiply the result by 85 per cent. of the boiler pressure in pounds, and divide by the diameter of the driving wheels, also given in inches. The quotient is the tractive effort in pounds.

The formula for calculating the tractive power of a Shay locomotive as given by the Lima Locomotive & Machine Company is as follows:

$$T = \frac{d^2 \times s \times 1.5 \times P \times G}{D \times p}$$

where  $d$  is the diameter of the cylinder and  $s$  is the stroke, both in inches;  $P$  is the mean effective pressure, which the Lima people take as 75 per cent. of the boiler pressure.  $G$  is the number of teeth in the gear rim, and  $p$  the number of teeth in the pinion. The constant 1.5 is introduced because there are three cylinders used.

The formula is similar to that for an ordinary simple engine with the exception of the constant 1.5, and the gear ratio, which for the large Shay locomotive is about 2 to 1. The Master Me-

chanics' Association use 85 per cent. of the boiler pressure as the mean effective pressure in the cylinders, and this has become the accepted practice. The Shay locomotive builders take 75 per cent. of the boiler pressure for their M. E. P., and this may possibly be nearer actual fact on the average than the M. M. rule.

therefore, do not appear as separate figures in the rule. The ordinary tractive effort formula when written out in full, and as it is logically constructed, becomes: area of the cylinder, multiplied by twice the stroke, multiplied by two, for the pair of cylinders, multiplied by the M. E. P., divided by the circumference of the driving wheel. In mathematical form the equation stands:

$$T = \frac{d^2 \times .7854 \times 2 \times s \times 2 \times P}{D \times 3.1416}$$

In this fraction, as will be seen, the figures cancel out entirely, and leave the letters. In the formula for the Shay engine the cancellation will leave a constant of 1.5 for the three cylinders.

The engine shown in the illustration was built for service on the Denver & Rio Grande, though it bears the initials of Rio Grande Western, which is one of that company's leased lines. This geared locomotive has cylinders  $14\frac{1}{2} \times 15$  ins., 40 in. driving wheels, 200 lbs. boiler pressure, ratio of 2 to 1 between gear and pinion, and its calculated tractive power is about 35,479 lbs.

There is a manufacturing company over in Jersey City, N. J., which have recently issued a neat little reminder of their existence, or whatever you like to call it. In order to compass the end they have in view, they are issuing to their numerous friends and well-wishers a souvenir in the shape of a pocket com-



GEARED LOCOMOTIVE FOR THE RIO GRANDE WESTERN.

pass, about  $1\frac{3}{4}$  ins. in diameter, the needle of which points to the north, while the whole thing points to the Smooth-On Company. Their idea is that with the aid of this compass, if you are in a sea of troubles, you can steer your course smoothly on to their cements, gaskets or packing. These are three good points on the back of the souvenir, while, as you know, there are, of course, 32 points on the face of the compass. The curious part about it all is that if you set your course by any of the three points on the back, the company will be able to trim their "sales" to suit the favoring gale, and all hands will be on deck. The souvenir, which has a glass bottom and nickel rim, is mailed in a

reast pasteboard receptacle, and the act of putting it in this little case is called boxing the compass in the Smooth-On Company's office. Write to them to box the compass for you.

### Line Clear for 1906.

A calendar which may be described in almost the words of poet Keats as "A thing of beauty and a joy forever," has been issued by the Union Switch & Signal Company, of Swissvale, Pa. It is, in fact, a colored picture measuring 14 ins. wide by 21 ins. high and represents a passenger train drawn by a modern 4-6-0 engine bowling along the down line of a double track road, and just about to pass a Union electric semaphore signal.

The scene is taken from an actual view of an installation on one of the large railroads running into New York and represents the train proceeding along the bank of a beautiful river backed in the purple distance by the highlands through which the river flows. The semaphore marks the beginning of a block governing the up track and the circular column carrying the signal arms is in the immediate foreground of the picture. The home and distant blades have, therefore, their reverse sides toward the spectator and are made of celluloid colored yellow. The home blade has the standard square end with the usual black line painted near its end, and the distant arm below it has the fishtail end and the black chevron to match. Both the signal arms are movable and the spectacles for each shows the green "proceed" color, and the home has the red for a positive stop. The distant signal shows also the green light for proceed and the distinctive tawny caution light, now recognized as standard practice. The middle "eye" in each spectacle provides for any possible sag in the semaphore arms, so that no ambiguity in the indication given can occur.

The calendar is a perpetual one and is regulated from day to day by moving the edges of three little cardboard disks which show the day of the week, the day of the month and the name of the month. Thus the calendar correctly indicates the date, and, like the signals by the river side, there is no ambiguity in what they show. A few facts about signals and some figures concerning the company's work are given, and the whole forms a useful and artistic calendar which, like the signal installation, does not grow old with the march of time or with the passing of trains. Write to the Union Switch & Signal Co. and ask them for the calendar, if you want to make a signal success of keeping track of the days as they come and go on your life line.

# Of Personal Interest.

Mr. W. L. Kellogg, master mechanic of the Pere Marquette, has had his office moved from Grand Rapids to Detroit, Mich. He has been placed in charge of the car department in addition to his duties as master mechanic.

Mr. A. W. Johnson has been appointed general manager of the New York, Chicago & St. Louis, with headquarters at Cleveland, O. He has been with this road for over twenty years, during the last twelve of which he has been general superintendent of the road. Mr. Johnson is a Bostonian by birth and is a graduate of the Massachusetts Institute of Technology. His first railroad work was as clerk and draftsman in the office of the general superintendent of the Pittsburgh, Cincinnati & St. Louis,



A. W. JOHNSON.

and later on he became assistant engineer of that road. In January, 1882, he accepted the position of chief engineer of the Toledo, Delphos & Burlington, and not long after he took the superintendency of the Leavenworth, Topeka & Southwestern. In 1884 he went to the Nickel Plate as division engineer, and his progress on that road has been one of steady advancement ever since, having held successively the positions of division superintendent, general superintendent and now general manager.

Mr. W. B. Ott, assistant engineer of motive power of the Pennsylvania, at Buffalo, N. Y., has been transferred to Altoona, Pa., in a similar capacity.

Mr. John T. Flavin, assistant master mechanic of the Indiana, Illinois & Iowa, has been appointed master mechanic of the Indiana Harbor also, with headquarters at Kankakee, Ill.

Mr. O. P. Hiltbiddle has been ap-

pointed master car builder of the Southern Indiana, with headquarters at Bedford, Ind.

Mr. C. W. Cross, master mechanic of the western division of the Lake Shore & Michigan Southern, has been appointed to the newly created position of master of apprentices.

Mr. James C. McCarty has been appointed master mechanic of the Lake Shore & Michigan Southern, with headquarters at Elkhart, Ind.

Mr. C. H. Quereau has been appointed superintendent of electrical equipment of the New York Central, and will have charge of all electrical rolling stock on that road. He was formerly engineer of tests of the N. Y. C. at West Albany.

Mr. A. W. Byron has been appointed assistant master mechanic of the Pennsylvania, with headquarters at Olean, N. Y.

Mr. W. N. Cox, superintendent of the Atlanta & West Point, has been appointed superintendent of transportation and machinery of the same road, with headquarters at Montgomery, Ala., and the office of superintendent has been abolished.

Mr. W. C. Dailey, of Pueblo, Colo., formerly connected with the Union Pacific, has been appointed roundhouse foreman on the Missouri, Kansas & Texas, at Smithville, Tex., vice Mr. H. Kistner, transferred.

Mr. Floyd Dick Richason, an engineer on the Panhandle, has been promoted to be assistant road foreman of engines of the Logansport division of the Pittsburgh, Cincinnati, Chicago & St. Louis Railway. He has been running an engine on that division for a number of years. Mr. Richason's headquarters are at Logansport.

Mr. Henry J. Beek, road foreman of engines on the Reading, has been promoted to general locomotive inspector. The position is a new one on that road.

Mr. J. T. Sheahan has been appointed master carpenter of the Wabash, with office at Moberly, Mo., vice Mr. James Stannard, resigned.

Mr. George W. Strattan, master mechanic for nearly 35 years of the Pennsylvania's machine shops at Altoona, has been retired on a pension, having attained the age limit of 70 years. His fellow employees gave a banquet in his honor.

Mr. G. M. Miller, formerly traveling engineer of the Ferro-Carril International, has been appointed traveling en-

gineer of the Chihuahua division of the Mexican Central, with headquarters at Chihuahua, Mex.

Mr. W. H. Marshall has been elected president of the American Locomotive Company and leaves the general managership of the Lake Shore & Michigan Southern to accept the position. He has had a wide and varied experience and has held positions in the motive power and the operating departments of several large railroads. Mr. Marshall was in former years well known in technical journalism and was connected with one or two railroad papers in New York and Chicago, and in May, 1897, he left the editor's desk and entered the service of the Chicago and North-Western as assistant superintendent of mo-



W. H. MARSHALL.

tive power. Two years later the Lake Shore & Michigan Southern offered him the position of superintendent of motive power. That company, recognizing the fact that a successful motive power superintendent has in him the qualifications which go to make up the equipment of an efficient operating officer, transferred Mr. Marshall to the general superintendent's chair in 1902, and the following year advanced him to the position of general manager. The passenger 2-6-2 engines, known on the Lake Shore as Class J, were designed by Mr. Marshall while in charge of the motive power of that road. These engines were probably the first to be built with boilers having 19 ft. tubes, and altogether their general design marked an advance in locomotive practice in this country. The American Locomotive Company are to be congratulated on having secured the combination of motive power and executive ability which is represented in Mr. Marshall's progress.

Mr. Thomas Madigan, formerly roundhouse foreman at Manchester on the Lehigh Valley Railroad, has been promoted to the position of master mechanic on the same road, with headquarters at Buffalo, vice Mr. J. H. Williams, transferred.

Mr. W. G. Hovey, who has recently been appointed construction manager of the General Railway Signal Co., was born in Maine in 1860. He entered the railway service in 1889 on the N. Y., N. H. & H. as a lineman in the Signal Department. In 1890 he went to the Hall Signal Co. as foreman of installation, and two years later was made general foreman of installation. In 1892 he became superintendent of signals on the Chicago & Northwestern. In 1900 he joined the Taylor Signal Co. as superintendent, and later was appointed their eastern agent, afterwards being appointed resident manager of the General Railway Signal Co., upon the acquisition by the latter company of the business of the Taylor and Pneumatic Signal companies.

Mr. Henry M. Sperry, until recently consulting signal engineer of the Hudson Companies, has been appointed resident manager of the General Railway Signal Company, with headquarters in New York. Mr. Sperry was for a number of years connected with the Union Switch and Signal Company and brings to the service of the company he has just joined the ripe experience of many years of practical work. He is consulting engineer of the Kinsman Block Signal Company, of New York.

Mr. William J. Leiby has been appointed road foreman of engines of the Reading and Wilmington and Columbia Divisions of the Philadelphia & Reading Railroad, vice Mr. H. J. Beck, assigned to other duty.

Mr. Sheldon E. Bent has become connected with the track department of the Railway Appliances Company of Chicago. He is a railroad man having large acquaintance, having been located in Mexico the last six or seven years as superintendent of transportation of the Oceanic of Mexico and as general superintendent of the Vera Cruz & Pacific. He was at one time superintendent and then purchasing agent of what is now a part of the Brooklyn Rapid Transit Co.

Mr. I. B. Thomas has been appointed master mechanic of the Pennsylvania Railroad shops at Altoona, Pa., vice Mr. G. W. Strattan, resigned.

Mr. J. H. Williams, formerly general foreman of the Buffalo shops of the Lehigh Valley Railroad, has been appointed master mechanic of the Wyoming division, with office at Coxton, vice Mr. Chas. Wilson, resigned. With this change the master mechanic's office moves from Wilkes-Barre to Coxton so as to have that officer on the main line and in

close touch with the maintenance of the heavy freight power which runs over the short line through Wilkes-Barre.

Mr. H. L. Hungerford has been appointed superintendent of the Little Rock terminals of the Missouri Pacific, in place of Mr. J. W. Dean, transferred. Mr. Hungerford's headquarters are at Argenta, Ark.

Mr. B. G. Fallis has been appointed superintendent of the Illinois division of the Missouri Pacific, with headquarters at Chester, Ill.

Mr. A. J. Alexander has been appointed superintendent of the Arkansas division of the Missouri Pacific, with headquarters at Little Rock, Ark.

Mr. F. W. Green has been appointed superintendent of the Memphis division of the Missouri Pacific, with headquarters at Wynne, Ark.

Mr. J. W. Dean has been appointed superintendent of the Central division of the Missouri Pacific, with headquarters at Van Buren, Ark.

Mr. Frank E. Christy has been appointed roundhouse foreman of the Buffalo & Allegheny division of the Pennsylvania, with headquarters at Pittsburgh, Pa.

Mr. E. L. Fraser has been appointed assistant roundhouse foreman of the Pennsylvania, with headquarters at Altoona, Pa.

Mr. W. P. Chrysler has been appointed master mechanic of the Chicago Great Western, with headquarters at Oelwein, Ia.

Mr. J. E. Chisholm has been appointed general master mechanic of the Chicago Great Western, with headquarters at Oelwein, Ia.

Mr. J. B. Yohe, formerly general superintendent of the Pittsburgh & Lake Erie, has been appointed general manager of the same road, with headquarters at Pittsburgh, Pa.

Mr. Daniel J. Malone, master mechanic of the Oregon Short Line in Salt Lake, has been transferred to the Ogden shops of the Southern Pacific, to succeed E. M. Luckett, resigned.

Mr. J. R. Alexander, car and steam heat inspector, has been appointed general road foreman of engines of the Pennsylvania, with headquarters at Altoona, Pa.

Mr. William Elmer, Jr., has been promoted from assistant engineer of motive power of the Pennsylvania, at Altoona, to be master mechanic of the Pittsburgh machine shop of the same road.

Mr. L. E. Hassner, general foreman of the Illinois Central, at East St. Louis, has been appointed master mechanic of the same road, with headquarters at

Clinton, Ill., vice M. J. McGraw, resigned.

Mr. M. J. McGraw, formerly master mechanic of the Illinois Central, at Clinton, has been appointed master mechanic of the Missouri Pacific, with headquarters at Fort Scott, Kan.

Mr. W. C. Smith, master mechanic of the Missouri Pacific, at Fort Scott, has been transferred to Kansas City, to succeed William Naughton, resigned.

Mr. G. G. Davis has been appointed general foreman of the car department of the Cleveland, Cincinnati, Chicago & St. Louis, with headquarters at Indianapolis, Ind.

Mr. Robert McMeen has been appointed road foreman of engines of the Lake Erie & Western, with headquarters at Tipton, Ind.

Mr. W. E. Preston has been appointed shop foreman of the Seaboard Air Line, with headquarters at Hamlet, N. C.

Mr. H. S. Mored has been appointed traveling engineer on the main line of the Chicago, Burlington & Quincy, between Galesburg, Ill., and Ottumwa, Ia., with headquarters at Burlington.

Mr. Geo. Herren has been appointed master mechanic of the Montana division of the Great Northern.

Mr. G. S. Allen, division master mechanic on the Philadelphia & Reading, at Tamaqua, Pa., recently celebrated his golden wedding. He began his career as a railroad man on the Little Schuylkill branch in 1854 and has been with the company ever since. He has been employed in various capacities and ran a locomotive for some years. He learned the machinist trade at the old Carter Allen shop, now the Vulcan Iron Works, at Tamaqua. Since 1871 Mr. Allen has held the position of master mechanic of the company's shops at Tamaqua, where he was born, and where he has lived all his life. His grandfather was Capt. George Wadlow Allen, of the British navy, and his father also served in the Royal navy before coming to America. On the anniversary Mr. and Mrs. Allen were the recipients of a present in the shape of a gold set of tableware from the officials of the Shamokin division and the foremen in the shops.

Mr. Wilber H. Traver, connected with the Rand Drill Co. for 12 years as manager of the Chicago territory until the consolidation of the Ingersoll-Rand companies, after which time he was manager of the railroad department, with headquarters in Chicago, has now severed his connection with the Ingersoll-Rand Company. Mr. Traver has accepted service with the Chicago Pneumatic Tool Co. as manager of the mining and contract department. He will devote his time and attention principally to the sale of air compressors, rock drills and mining machinery. Mr. Traver was for years an



# Old-Timer Talks No. 1



Now it's possible to avoid all hot crank pins or bearings, groaning cylinders, troublesome valves, and the like. It's just a simple matter of treatment.

When there's a groaning or squealing or heating-up, you can know for certain that the treatment ain't right. Bearings and pins always behave if you feed 'em as you should. Add a little of **Dixon's Graphite** to the oil and see how the hot bearings or pins cool off, every time.

And don't think you can fool 'em with "just as good" graphite—**Dixon's Pure Flake** is what they "call" for and insist on.



Course, "an ounce of prevention is better than a pound of cure." If you'll use **Dixon's Pure Flake** regularly, friction troubles will leave you for the other fellow.

My advice is to write the Dixon people for sample No. 69-C

**Joseph Dixon Crucible Co.**  
Jersey City, N. J.

official in the mechanical department of the Santa Fe and was known as a great hustler.

Mr. George Dickson has been appointed master mechanic of the Chicago, Cincinnati & Louisville, with headquarters at Peru, Ind.

Mr. C. H. Morrison, formerly signal engineer of the Erie, has been appointed acting electrical engineer, with headquarters at New York.

Mr. J. N. Mallory, formerly in the department of tests of the New York Central, has been appointed mechanical engineer of the Lehigh Valley, succeeding Mr. L. L. Bentley, resigned. Mr. Mallory's headquarters are at South Bethlehem, Pa.

Mr. J. F. Scott has been appointed master mechanic of the Ohio River & Western, with headquarters at Zanesville, O., succeeding V. B. Stubbins.

Mr. C. B. Wilburn has been appointed general superintendent of the Atlantic & Birmingham, with headquarters at Waycross, Ga.

Mr. C. R. Burroughs, general foreman of the Southern Pacific shops at San Francisco, Cal., has been appointed assistant master mechanic of the coast division on the same road, with office at San Francisco.

Mr. M. E. Wells has been appointed assistant master mechanic of the Wheeling & Lake Erie Railroad, with office at Columbia, Ohio.

Mr. Enoch Brown, tall, stalwart and healthy, carrying upon his shoulders the weight of 70 years, holds the undisputed distinction of being the oldest locomotive engineer in the world. He lives at Amagaria, a small village in the Province of Ontario, having a population of about two hundred inhabitants, situated a mile or so from the Fort Erie race track on the Grand Trunk Railway.

Enoch Bown is an Englishman by birth. He is a native of Lancashire, England, and was born October 14, 1826. Enoch Bown was only 14 years old when he began railroading. He secured a position as helper on the old London & Birmingham, now the North-Western Railway. He worked at plate laying. When 17 years old left the section and went into the shops, serving two years, assisting the fitter, then two years firing, and in 1847 took charge of an engine doing work on the London & Birmingham road.

In 1857, with seven years' successful experience as an engineer, then 28 years old, Enoch Bown was seized with the desire to cross the Atlantic, so he moved to Canada, immediately securing an appointment as engineer on the old Great Western. He ran between Niagara Falls, London and Windsor.

He also engineered on the Buffalo and Lake Huron. These lines have since been improved and acquired by the Grand Trunk. His familiarity with the iron steeds which had been his life's companions brought about his appointment in 1872 as foreman of engines of the Grand Trunk lines. He held this position for a quarter of a century, and found himself 71 years old and ready for retirement.

He decided to work some more, and was soon picked up to operate the dummy car on the International Bridge. For eight years this fine looking and gray whiskered engineer was daily seen at his post, but January 1 last he closed his labors, and now lives a quiet life among his friends and neighbors in the passive hamlet of antiquated Amagaria.

## Mr. Westinghouse Receives a Medal.

"For the invention and development of the air brake," Mr. Geo. Westinghouse was recently awarded a John Fritz medal, which is the second award of this medal yet made, the first being made last year to Lord Kelvin, formerly Sir William Thompson, one of the foremost scientists of the age, for his invention in cable telegraphy.

The committee making the award consisted of sixteen members, four from each of the national engineering societies; and, by the award of the medal to Mr. Westinghouse, recognizes the air brake as one of the greatest inventions in railroad transportation.

This medal was established by the friends of John Fritz, of Bethlehem, Pa., on his eightieth birthday, which occurred August 21, 1902, and is to be awarded each year to the inventors and originators of the most useful scientific achievements, and in "perpetual honor of John Fritz and to the glory of engineering."

## Obituary.

George W. Little, assistant treasurer of the Pittsburgh Spring & Steel Company, died on Friday, February 16, of pneumonia, after an illness of one week. Mr. Little had a long experience in the spring business, having been originally connected in the accounting department with A. French & Company some thirty years ago, and he continued with that company and its successors until 1902, when he became assistant treasurer of the Pittsburgh Spring & Steel Company, which position he held at the time of his death. His long experience in the spring business made him a valuable member of the company, and his death will be a great loss, not only to his immediate associates, but also to the community in which he was held in high esteem.

### Respect for Law.

In speaking on "The Development of Transportation" at the fifth annual banquet of the Community of Freight Traffic Interests, recently held in New York, Judge Charles F. Clark said many things which are worthy of careful attention. Among his reported utterances we find him saying:

"The great majority of those who are in control of transportation affairs mean and endeavor to be entirely just in dealing with the public. The trouble is that here and there we find one totally reckless of the rights of the people. These incur the indignation and hostility of the masses, who fail to discriminate and visit their wrath upon the entire class.

"There is no enemy so much to be feared by those identified with corporate enterprise as the member of their own craft, who, conscious of his power, is arrogant and defiant. It is a fearful thing when one conspicuous and potential in commercial life shows contempt for the powers that be and refuses to recognize the force of the very law upon which he is dependent for the protection of his own interests. When the general public follows his example, our citizens become a desperate and dangerous mob. The only way to perpetuate the enjoyment of the privileges we claim is to exhibit ceaseless regard for the rights of others."

The increasing business of the H. W. Johns-Manville Company has necessitated considerable additions to their sales force, and the recent establishment of two new departments at their head offices in New York. One of these is the Railroad Department, devoted to railway supplies, of which the company manufacture a large variety. Mr. J. E. Meek has been appointed manager of the new Railroad Department. In addition to this, an Export Department has been organized under the management of Mr. William Angevine in order to facilitate the handling of the foreign business of this company.

The Westinghouse Machine Company have opened a Philadelphia sales office in Room 1003 North American Building. The establishment of this office was necessitated by their rapidly expanding business in this territory, particularly in gas engines and Westinghouse Parsons steam turbines, and is in line with the progressive policy of the company to establish headquarters in all large industrial cities.

The temperature of steam under 115 pounds pressure is 327.6 degrees, at 215 pounds it is 381.6 degrees.

### Model Club for Employees.

The Allis-Chalmers Club, of Milwaukee, Wis., has issued an attractive little brochure containing its constitution and by-laws, which are very complete and concise. The printing of these rules is not, in itself, particularly noteworthy, but it calls attention to a class of organizations that are being formed in connection with some of the larger manufacturing and industrial concerns in the country. The clubs are designed to contribute to the comfort, social intercourse and advancement of employees. The Allis-Chalmers Co. has established for its office men, superintendents and foremen a well-appointed club, occupying quarters in a former mansion house near the works, where, for a nominal yearly fee, members are given all the benefits usually found in such organizations. During the noon hour a course dinner is served at approximately what the service actually costs, and supper may also be had by those who are obliged to stay late at the office.

As the club building stands in a residence district and is easily accessible from all parts of the city, it is kept open every evening for the benefit of members, who make free use of the periodicals, games, etc., contained in the reading room. Special evenings are also frequently set apart for general receptions and entertainments given separately by members of either sex, the annual dues being devoted to a fund for such purposes. The liberal action of this well-known company in thus establishing the club is worthy of imitation, and the benefits derived from such an organization cannot fail to promote a loyalty of service which is one of the assets of the company, though it may not appear on the ledger.

The Falls Hollow Staybolt Company, of Cuyahoga Falls, Ohio, has sent us a very artistic calendar for 1906 which contains a most effective sepia reproduction of A. C. Gow's picture of "Washington's Farewell to His Generals." The original, which is the work of a distinguished English artist, was shown at the Louisiana Purchase Exhibition. It was one of the successful exhibits in the foreign department, and a replica of it, 11x5½ ins., is on the calendar. The artist has chosen the moment of Washington's departure as he is about to go down the steps of the quay on his way to Annapolis to resign his commission. He is surrounded by all his generals and in the picture is represented grasping the hand of General Knox. The company are to be congratulated on the high-class calendar which they are issuing. Write direct to them for one if you are in want of a calendar which is equally effective in the office or the home.

## The Best and Cheapest Books for Railroad Men

**AIR BRAKE CATECHISM** Price, **\$2<sup>00</sup>**

By Robert H. Blackall. 20th Edition. Contains 1500 Questions and their Answers on the Westinghouse Air Brake, which are strictly up-to-date. Includes two large Westinghouse Air Brake Educational Charts printed in colors. Gives the necessary information to enable a railroad man to pass a thoroughly satisfactory examination on the subject of Air Brakes. The author's many years' experience as Air Brake Inspector and Instructor enables him to know at once how to treat the subject in a plain, practical manner. Endorsed and used by Air Brake Inspectors and Examiners on nearly every railroad in the United States. The standard and only complete work on the subject. 312 pages.

**LOCOMOTIVE BREAKDOWNS AND THEIR REMEDIES** Price, **\$1<sup>50</sup>**

By Geo. L. Fowler. Just Issued. Tells how and what to do in case of an accident or breakdown on the road; includes special chapters on Compound Locomotives. Better procure a copy, as it contains 500 Questions and their Answers on Accidents and Breakdowns.

**LOCOMOTIVE CATECHISM** Price, **\$2<sup>00</sup>**

By Robert Grimshaw. 23rd Edition. Is right up-to-date and contains twelve large Folding Plates and 1600 Questions and Answers on How to Run a Locomotive. The Standard Book on the subject, being written in plain language and free from mathematical formulae and complex problems.

**NEW YORK AIR BRAKE CATECHISM** Price, **\$1<sup>00</sup>**

By Robert H. Blackall. The only complete treatise on the New York Air Brake and Air Signaling Apparatus, giving a detailed description of all the parts, their operation, troubles, and the methods of locating and remedying the same. 250 pages.

**COMBUSTION OF COAL AND THE PREVENTION OF SMOKE** Price, **\$1<sup>50</sup>**

By Wm. M. Barr. Contains over 800 Questions and their Answers on the Science of Steam Making.

**AIR BRAKE CHARTS** Price, **50c.**

Showing the Westinghouse Equipment in ten colors, including freight and passenger engine. Every railroad man should possess these charts at this low price.

A Special Circular of any of these books sent on request. Any of these books sent pre-paid on receipt of price.

Agents Wanted at Every Terminal. Write for our special terms. You can make equal to a month's pay selling our books on the side

The Norman W. Henley Pub. Co.

132 Nassau Street, New York, U. S. A.



# RAILROAD SUPPLIES

## Announcement

We have recently organized a **RAILROAD DEPARTMENT** to take care of our large and rapidly increasing business in Railroad Materials and Supplies. We are now making a specialty of Insulating Materials, Packings, etc., for this trade, as follows:

- Smoke Jacks
- "Transite" Fireproof Lumber
- Asbestos and Magnesia Locomotive Lagging
- Vulcabeston Pump Packing
- Vulcabeston Gaskets
- Vulcabeston Rope Packing
- Train Pipe Covering
- Kearsarge Gaskets
- All grades of Asbestos and Magnesia Pipe Covering
- Hair Felt
- Keystone Hair Insulator
- Asbestos Cements
- Retort Cements
- Canadax Wick Packings
- High Pressure Asbestos Packing
- Asbestos Roofing
- Portland Sectional Conduit

WRITE NEAREST BRANCH FOR BOOKLET

## H. W. JOHNS-MANVILLE CO.

Manufacturers of ASBESTOS and MAGNESIA PRODUCTS, ELECTRICAL INSULATING MATERIALS, "NOARK" FUSE DEVICES, ELECTRICAL RAILWAY SUPPLIES, ETC.

- |              |               |             |
|--------------|---------------|-------------|
| NEW YORK     | ST. LOUIS     | KANSAS CITY |
| MILWAUKEE    | PITTSBURG     | MINNEAPOLIS |
| CHICAGO      | CLEVELAND     | LITTLE ROCK |
| BOSTON       | SAN FRANCISCO | NEW ORLEANS |
| PHILADELPHIA | LOS ANGELES   | LONGON      |
|              | SEATTLE       |             |



### Locomotive Oil Pump.

To meet the difficulties incident to supplying oil to a modern locomotive using steam at high pressure and in many cases superheated, a locomotive oil forcing pump has been put on the market. The style of pump is shown in our transparent engraving, and it is built by the Sight Feed Oil Pump Co., of Milwaukee.

The body of the pump is made of cast iron, which, after being faced on all sides, is drilled out for the plungers and passageways. The plungers are made of steel, provided with machine cut racks, and are operated by means of steel gear shafts. One plunger in each pump, when only one kind of oil is used, serves to circulate the oil from the tank up through a channel over the drip nozzles, the excess of oil pumped each stroke returns through one of the hollow studs back to the tank. This plunger is able to more than supply all feeds. The circulation of the oil keeps it thoroughly mixed, and the flow past the drip nozzles tends to wash away any small particles of foreign matter that might otherwise lodge there. Each discharge line has an independent pumping mechanism, consisting of a plunger, two large ball check valves, and a separate discharge line. The pump shown is the one-feed or smallest size, and illustrates but one of these separate pumping mechanisms.

The company are making sight feed pumps having from one to sixteen feeds. The amount of oil being fed to any given point is adjusted by the valve shown on top, and the drops are readily seen by the engineer as they flow down through the recessed cavity behind which is a nickel disk. As soon as a drop of oil falls into the hole below the drip nozzle, the pump plunger on its up stroke produces a partial vacuum into which the drop of oil is drawn. The down stroke forces it past the check valves and out into the delivery pipe.

The front check valve used will sustain a pressure of 1,000 lbs. per sq. in., and the rear check is used as a further assurance against leakage. It is plain that with a check valve provided at the extreme discharge end of each feed line, the piping will at all times be held full of oil, and the moment a drop is forced past the first check in the pump, a corresponding amount must be squeezed out at the discharge end, to make room for it. The tank is provided with a

threaded cap, on the top, under which is a large strainer, readily removable for cleaning. A protected gauge glass shows the level of the oil.

For locomotive work, the same style of pump body is used as that for stationary work, but it is enameled instead of being polished, and is provided with a different style of pipe connection for the feed lines. The locomotive oil pump, however, is driven by a small motor. This motor is, in principle, a double acting, self-contained engine, either operated by steam or compressed air, the latter being in many ways preferable. This little motor rotates the gear shaft, through an angle of 72°, which gives the forcing plungers their proper travel. When the feeds are once set for their proper flow, all the engineer has to do is to open the air valve to the motor,

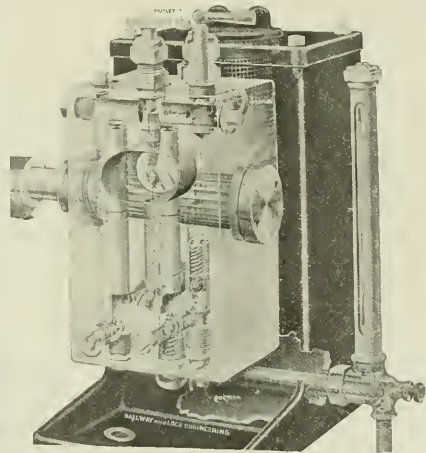

SIGHT FEED OIL PUMP.

and the apparatus will take care of itself. One other very important feature of this particular type of force feed lubricator is that it will satisfactorily and continuously feed a mixture of powdered graphite or mica and oil. By reason of the fact that it is not necessary to start the oil pump before starting the engine, no oil need be wasted at such times, and because of the convenient means of stopping the motor when halting at stations, oil flow can be easily shut off at such times.

The Engineering Standard Committee of the East Indian Railways have reported in favor of widening the railway tracks to 5 ft. 6 ins. Two special locomotives are being built for that gauge and extensive experiments will be made on a short distance railway. The limit of height has been reached, and the future may see a general increase in the width of railway tracks.

### Crosshead Jack or Fulcrum.

The illustration which we give is what Mr. John F. Long, the general foreman of the 'Frisco shops at Monet, Mo., calls a crosshead jack. It is made of two pieces of flat iron bolted together at regular intervals and held a specified distance apart by thimbles round each bolt. When placed alongside of the guide bars it forms a series of convenient fulcrums for the bar which a workman uses to move the crosshead in either direction when re-

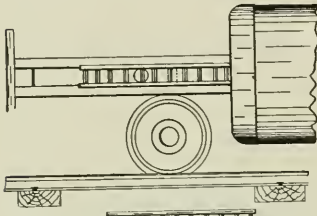

CROSSHEAD JACK.

newing piston rod packing or adjusting the connecting rod to the wristpin, or, indeed, for any purpose which requires piston or crosshead to be placed in a particular position. The appliance has the advantage of being one piece, and when used it generally replaces a lot of blocks and nuts and odds and ends which go to build up a temporary but fearfully and wonderfully made crosshead fulcrum which usually falls down between every jerk on the bar.

An announcement is made that the railway express companies will no longer grant free transportation of packages to favored interests. We wonder who the "favored interests" were. The express companies have been the most vicious blood suckers on small lines of business the country has suffered from, yet they have been powerful enough to restrain public sentiment from demanding that they be treated as common carriers.

Canadian inventors are not so thick a crop as in the United States, but we notice that during 1905, among other inventions, there were recorded at Ottawa two air brakes, three couplers, two cars, heating apparatus for roundhouses, a hood and smoke pipe for roundhouses, and a car and engine replacer. There was also patented a mechanism for controlling trains, on the principle of an electric circuit in combination with the air brake.

### Fire and Acid Proof Jacks.

The unsatisfactory results obtained from the use of metal and wood smoke jacks for roundhouses has induced many railways to turn to asbestos as a more

satisfactory material, and Transite Asbestos Fire and Acid Proof Smoke Jacks have been brought forward for this purpose. Metal jacks deteriorate under the effects of gaseous vapors and they also collect condensed vapor on the inner surface, and the drip upon the engine under such a jack is troublesome.

Transite Asbestos Smoke Jacks possess durability, indestructibility and lightness of construction. Transite is said to last as long as the building itself, and it is absolutely fire, gas and weather proof, and is unaffected by heat and cold. It weighs only one-fifth as much as cast iron, and can be worked and handled in the same manner as wood.

The development of Transite Asbestos Smoke Jacks has passed the experimental stage, and they have already been adopted by many large railroads in this country.

Transite Asbestos Fireproof Lumber, from which the jacks are made, has a large field of usefulness, not only in the railway industry, but in many other lines of construction.

This material was originally designed for fireproofing the flooring and for the insulation of electrically propelled cars, and was first used by the Interborough Rapid Transit Company, of New York, both in their elevated and subway cars. The lumber, as its name indicates,



ROUNDHOUSE SMOKE JACK.

is made of asbestos, varying in thickness from  $\frac{1}{8}$  in. to 1 in. and can be obtained in standard size sheets 40x40 in. or 42x48 in.

Transite Asbestos Lumber Smoke Jacks are manufactured by the H. W. Johns-Manville Company, of New York, and they have prepared a booklet on the subject which will be sent free to those who write to the company for a copy.

# GOLD Car Heating and Lighting Co.

Manufacturers of

**ELECTRIC,  
STEAM AND  
HOT WATER  
APPARATUS  
FOR RAILWAY CARS**

**EDISON  
STORAGE  
BATTERY  
FOR RAILWAY CAR  
LIGHTING**

Catalogues and Circulars  
cheerfully furnished

**Main Office, Whitehall Bldg.  
17 BATTERY PLACE  
NEW YORK**

# Homestead Valves

Straightway, Three-way and Four-way, and

# Homestead Locking Cocks

Are Famous the World Over

They cost more, but are worth very much more than other makes. Try them and see.

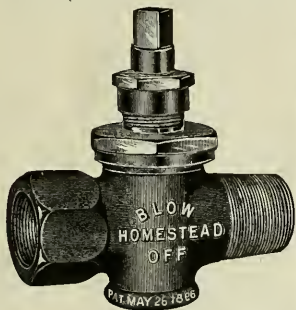

Brass, 1 1/4 in., \$6.00 net

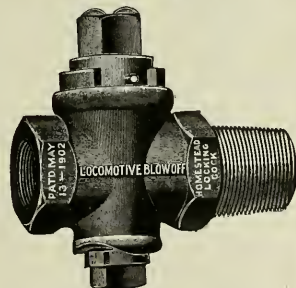

Iron Body, Brass Plug, 1 1/4 in., \$4.00 net

**Homestead Valve Mfg. Co.**  
WORKS, HOMESTEAD, PA. PITTSBURG, PA.

## American Locomotive Sander Company

13th & Willow Sts., Philadelphia, Pa.

Proprietors and Manufacturers

LEACH, SHERRBURNE, DEAN, HOUSTON, "SHE" and CURTIS **SANDERS**

### THE ROBERT W. HUNT & CO.

Bureau of Inspection, Tests and Consultation,  
1137 THE ROOKERY, CHICAGO.  
66 Broadway, New York. Park Building, Pittsburgh.  
31 Norfolk House, London, Eng.  
Inspection of Steel Rails, Splice Bars, Railroad Cars, Wheels, Axles, etc. CHEMICAL LABORATORY—Analysis of Ores, Iron, Steel, Oils, Water, etc. PHYSICAL LABORATORY—Test of Metals, Drop and Pulling Test of Couplers, Draw Bars, etc.  
Efficiency Tests of Boilers, Engines and Locomotives.

### Plain Milling Machine.

We here illustrate a Newton plain milling machine, being used in a railroad shop in the process of milling shoes and wedges for locomotive driving boxes. This machine is one of the latest improved type and is worm driven, with a bronze worm wheel and hardened steel worm. It is built with a substantial angular rail. The carriage of the machine is exceptionally heavy, being 30 ins. wide, and can be made of any desired length. It is fed by means of a rack and spiral pinion, and has variable speed, produced by means of a friction disk, or where users so desire it, with a speed box having a positive feed of nine changes. The makers can furnish either the machine electrically driven, as we show it, or belt driven, if the custo-

mer desires that form. This machine can be used for a large variety of railroad work. It was originally intended for locomotive rod work, but can be used for locomotive driving boxes, rods, guide bars, and any class of work within the capacity of the machine. The tool complete weighs about 25,000 lbs., with a carriage suitable for milling work 10 ft. long.

A most attractive and artistic catalogue, in the form of a 6-leaf folder, has just been received from the Garlock Packing Company. On each of the leaves of this folder is shown some form of the Pitt metal packing made by this company. The half-tones are excellent, giving views in perspective with the packing exposed, and yet in place in the stuffing box of the

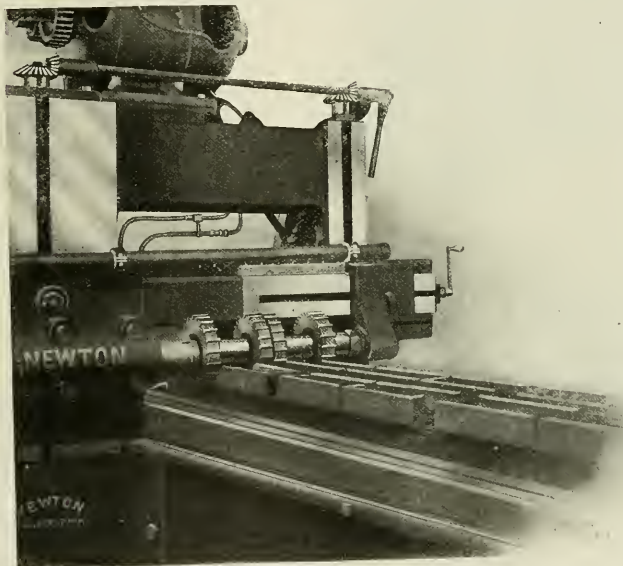

NEWTON MILLING MACHINE FINISHING LOCOMOTIVE DRIVING SHOES.

various kinds of engines to which it may be applied. The initial letter of the explanatory letterpress below each cut is embellished with a small panel picture indicating marine, locomotive and stationary steam engine practice. The folder is printed on paper of a delicate green shade, and the cover has a representation of James Watt forcing the steam in a boiling kettle to lift the lid by blocking the spout with a spoon. A sample order blank is given on the back of the folder and with other information of general interest to packing users. It makes what the company calls the "metal packing proposition" a pleasure and a useful reference circular. Write direct to the company, 136 Liberty street, New York, and you will receive a copy.

### Locomotive Cuts a Wide Swath.

The well-known firm of locomotive builders, Messrs. Robert Stephenson & Co., Ltd., of Darlington, Eng., have recently completed the largest engine ever built in the United Kingdom. It is destined for the Great Western Railway of the Argentine Republic in South America. It was taken to pieces and

### Conqueror Sander.

Our illustration gives a good idea of the new Conqueror. No. 4, Triple Drum Sander, made by the J. A. Fay & Egan Co., of Cincinnati, Ohio. The machine sandpapers work from 30 to 80 ins. wide and 8 ins. thick. The three steel drums carry paper of different grades and have a vibrating motion, and this prevents the formation of lines upon the surface of the material. The drums can be easily removed and any workman can readily replace the sandpaper.

There are eight feed rolls, four above and four below the pattern. These are

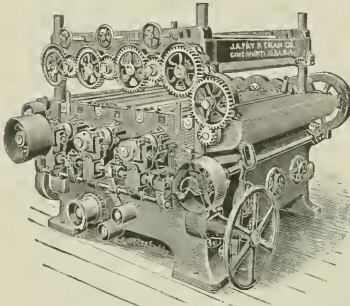

TRIPLE DRUM SANDER.

driven by a train of heavy expansion gearing. The pressure rolls are three in number, one over each drum, to hold the material firmly to the feed roll. The feed is governed by a double belt tightener, operated by a hand lever. A brush attachment cleans the work as it passes from the machine. The material is thus immediately ready for paint or varnish.

The J. A. Fay & Egan Company will be happy to furnish any further information concerning this machine to those who write to them direct, and they will send testimonials from those who have had experience with this sander.

An unfortunate foreign traveler, who was not furnished with a free pass on the special express, took advantage of a vacant berth on the front truck of the smoking car, and was caught in a fierce wilderness of waters when the tank scoop was lowered and the overflow drenched the truck. At the next stopping place the half-drowned tramp approached the fireman and said in a voice husky with emotion: "Say, pard, do you mind telling me the name of that river we swam through about ten miles back?"

The increasing business of the Westinghouse Electric & Mfg. Company in the territory covered by their Columbus, Ohio, office has necessitated their moving into larger quarters. They are located in Room 923, Columbus Savings and Trust building.

A cable order was recently received from London, England, asking for 300 Thor piston air drills, reversible flue rolling, reaming, tapping and wood boring machines and pneumatic hammers, made by the Independent Pneumatic Tool Company, of Chicago.

The domestic business of this concern has grown to such an extent that they regretfully admit being several months behind in their orders, the present capacity of their plant being said to be entirely inadequate to meet the demand for Thor tools. The company have, therefore, leased a large building adjoining their plant at Aurora, Ill., and intend to purchase \$50,000 worth of new machinery at once for installation therein. The factory plant is running night and day shifts and it is their intention to erect a large addition to it at the earliest possible date.

The American Balanced Slide Valve Company, of Jersey Shore, Pa., have, during the last six months, supplied the Pennsylvania with more than 700 of their latest type of valve.

There is a company in Detroit who have several patterns for the knuckle and parts for each of twenty-seven M. C. B. couplers. In that respect they are well equipped, but they want you to be well equipped also, because you may need knuckles or parts, or rather the cars under your control may need the knuckles, you of course have your own knuckles, one on each hand, and the Detroit concern would be sorry to hear that your knuckles were broken, or even cut of joint. They feel so much concern for you on the subject that they would like you to use one of your hands (with knuckle in good order), to write to them about their knuckles. If you do they will send you a neat little catalogue bound in leather telling about steel castings and a whole lot about a lot of knuckles. They say they will do this; make them knuckle down to it. Detroit Steel Casting Company is the address.

The Railway Appliances Company has taken the sales agency for the Elastic Nut, manufactured by the National Elastic Nut Company, of Milwaukee, Wis., and all inquiries in regard to price, etc., should be addressed to the Railway Appliances Company, 1175 Old Colony building, Chicago, or 114 Liberty street, New York. The well known company of Pedrick & Ayer, formerly of Philadelphia, now located at Plainfield, N. J., have been purchased and will hereafter be operated by the Railway Appliances Company.

## Locomotive Blow-Off Plug Valves

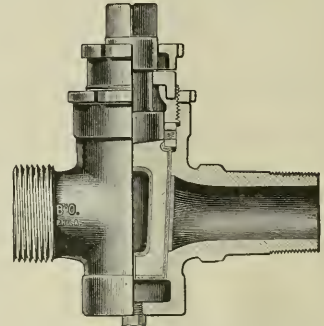

Fig. 9.

All Brass, extra heavy, with Cased Plug. For 250 lbs. pressure.

Made with Draining Plug to prevent freezing.

## Locomotive Gauge Cocks

For High Pressure

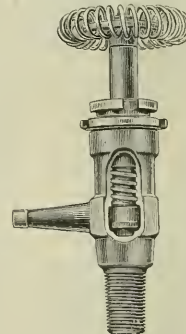

Fig. 23, with Wheel.

Bordo Self-Grinding Gauge Cocks, made with renewable Hard Bronze Disc. Opened and closed with a quarter turn. Guaranteed Steam tight under the most exacting conditions. Shanks Threaded to specifications for Locomotives.

## Swing-Joints and Pipe Attachment



Fig. 33.

May be applied between Locomotive and Tender.

These Swing-Joints are suitable for Steam, Gas, Air, Water or Oil.

Complete Booklet on Application

**L. J. BORDO CO.**  
PHILADELPHIA, PA.

## ENGINEERS AND FIREMEN, YOU CAN BE HELPED

in passing your examination  
for promotion or in keeping  
up-to-date.

### Spangenberg's Steam and Electrical Engineering

Price, \$3.50

Money refunded if book not  
satisfactory.



Steam and Electricity is dividing  
the railroad field. This book  
covers both subjects. Contains  
1035 questions and answers.

CUT OUT AND MAIL TO-DAY

**GEO. A. ZELLER BOOK CO.**

19 S. 4th Street, ST. LOUIS, MO.

I accept your offer to send me, express pre-  
paid, one of Spangenberg's Steam and Electrical  
Engineering, price, \$3.50, and enclose  
\$2 as first payment. The balance, \$1.50, I  
agree to remit in 50-cent monthly instal-  
ments, money or express order, or stamps.

Name.....

Street or Box No.....

City and State.....

# Patents.

**GEO. P. WHITTLESEY**

McGILL BUILDING WASHINGTON, D. C.

Terms Reasonable. Pamphlet Sent

# Molding Machines

Vertical Vibration, Power Draft

ALL KINDS OF MACHINES

**THE E. H. MUMFORD CO.,**

17th & Callowhill Streets, PHILADELPHIA, PA.

J. W. JACKMAN & CO., Ltd., 29 Victoria St., London, S. W.

### Handy Office Receiptacle.

Silence reigned in the outer office, broken only by the scratch and scrape of steel pens on the company's stationery, but the superintendent of motive power was chuckling to himself as he sat at his desk in the inner sanctum.

"Joe," he said, pleasantly, to his chief clerk, who had just entered with a pile of papers, "do you know the proper word for the diminutive of 'goose'?" "Yes, sir," replied the assistant, with the air of a man accustomed to give valuable information to his superior; "it is 'gosling,' of course." "Well," continued the S. M. P., warming to his subject, "did you ever hear of the foreigner who went into a restaurant, and, when ordering a young and very hot bird of that variety, asked for a 'goose's pup'?"

When the laugh, which startled the engine failure clerk at the farther end of the outer office, had died away, the chief clerk said, "I have a little lad in my home who is just six years old, and I gave him a child's desk and some writing paper for a Christmas present this year, and he takes me off in great style. The other day my wife, who, by the way, calls the boy 'his little literary-ship,' saw him seated at the tiny desk, with a bundle of papers in his hand. He was muttering to himself, 'Important papers, important papers; I must keep them safely,' and he hunted for a place to bestow them. There is a row of small pigeon-holes along the top of his desk, and he selected the center one, and, with a severe frown on his face, again said to himself, 'Important papers must be kept in the goose's hole,' and in they went."

"Mark that boy for promotion!" roared the S. M. P.; "and, here, Joe, you take this bundle of correspondence started by that old fool Snagsby about weighing drops of oil, and put it in the goose's hole until I ask for it—and, Joe," he called after the retreating figure, "get a whole lot of 'goose's holes' put in your own desk, and I'll fill them chock full. We need 'em on this road."

Some months ago the management of the Black Diamond File Works bought some real estate adjoining their works, and they erected a number of buildings in which to accommodate more machinery. They built large additions to their existing plant, thus securing considerably increased capacity. These im-

provements and enlargements have been going on during the year past and have now been completed. The result of all this is a much larger daily production, which it is hoped will enable them to more promptly fill all orders that may be placed with them. The wisdom of this course has been fully vindicated by the fact that even with the aid of their increased capacity, they are at the present time finding it a severe tax upon their manufacturing resources to keep up with the demands of the trade for Black Diamond Files. The G. and H. Barnett Company, of Philadelphia, are the makers of these files.

### Former "L" Puffer a Suburbanite.

Our little snapshot illustration shows a Forney type locomotive of the style which a couple of years ago were so familiar to New Yorkers, as the motive power of the Elevated. This engine is, however, no longer "up in the air," but has got down to earth and has been

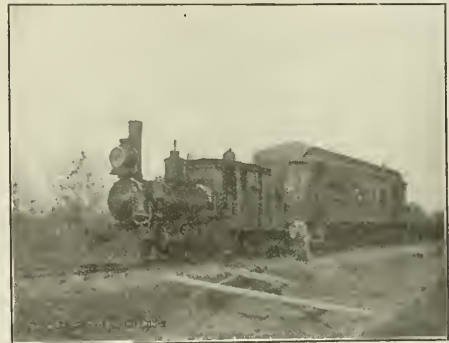

A FORMER "L" PUFFER DOWN TO EARTH.

furnished with a pilot, a headlight and a bell, the latter carried on the buffer beam on the left side. This "L" puffer, if we may so call it, now does business on the level, and has to look out for cows on the track, just like any ordinary locomotive. The Forney type of double-ender has been used on short suburban runs, but electricity as a motive power has been steadily advancing in this field of operation.

It does not follow because a tool or apparatus designed for a certain operation is different from what was previously used that it is necessarily superior. It does not follow because a novel method is introduced that it must be an improvement. Many things have been welcomed in shops to which the French saying applies: "The play was not worth the candle."

Mercury freezes at 38 degrees below zero and vaporizes at 662 degrees.

### The Instruction Car.

In the matter of mastering the growing intricacies of railroad mechanism, it is outside of the range of human accomplishment to have a superflux of knowledge. To know it all is an intellectual impossibility. New improvements crowd each other. Lord Bacon, the learned philosopher, said that reading maketh a full man, conference a ready man, and writing an exact man. The first is the underlying strata upon which the other two must depend, and while the instruction car may be said to give an opportunity to cultivate the conversational qualities, the reading is the leading prerequisite. The careful perusal and the quiet study of the thoughts embedded in the printed page is the best preparation for railroad men to understandingly secure the benefits of the necessarily brief explanatory statements made in the instruction car.

To this end RAILWAY AND LOCOMOTIVE ENGINEERING supplies this necessary adjunct. Its pages are filled with the expression of the best thoughts of the leading railroad men of our time. It has met the universal approval of the leading railway men throughout the world. The price, \$2 a year, places it within the reach of every railroad employe.

"Twentieth Century Locomotives," Angus Sinclair Co., deals comprehensively with the design, construction, repairing and operating of locomotives and railway machinery. First principles are explained. Steam and motive power is dealt with; workshop operations described, valve motion, care and management of locomotive boilers, operating locomotives, road repairs to engines, blows, pounds in simple and compound engines; how to calculate power, train resistance, resistances on grades, etc. Shop tools explained. Shop recipes, definitions of technical terms, tables, etc. Descriptions and dimensions of the various types of standard locomotives. The book is well and clearly illustrated and is thoroughly up to date in all particulars, fully indexed. Price, \$3.00.

"Locomotive Engine Running and Management," by Angus Sinclair, is an old and universal favorite. A well-known general manager remarked in a meeting of railroad men lately, "I attribute much of my success in life to the inspiration of that book. It was my pocket companion for years." Price, \$2.00.

"Practical Shop Talks." Colvin. This is a very helpful book, combining instruction with amusement. It is a particularly useful book to the young mechanic. It has a stimulating effect in inducing him to study his business. We sell it for 50 cents.

"Examination Questions for Promo-

tion." Thompson. This book is used by many master mechanics and traveling engineers in the examination of firemen for promotion and of engineers likely to be hired. It contains in small compass a large amount of information about the locomotive. Convenient pocket size. We cordially recommend this book. It sells for 75 cents.

The 1904 Air Brake Catechism. Conger. Convenient size, 202 pages, well illustrated. Up to date information concerning the whole air brake problem, in question and answer form. Instructs on the operation of the Westinghouse and the New York Air Brakes, and has a list of examination questions for engine-men and trainmen. Bound only in cloth. Price, \$1.00.

"Compound Locomotives." Colvin. This book instructs a man so that he will understand the construction and operation of a compound locomotive as well as he now understands a simple engine. Tells all about running, break-downs and repairs. Convenient pocket size, bound in leather, \$1.00.

"Catechism of the Steam Plant." Hemenway. Contains information that will enable a man to take out a license to run a stationary engine. Tells about boilers, heating surface, horse power, condensers, feed water heaters, air pumps, engines, strength of boilers, testing boiler performances, etc., etc. This is only a partial list of its contents. It is in the question and answer style. 128 pages. Pocket size, 50 cents.

"Care and Management of Locomotive Boilers." Raps. This is a book that ought to be in the hands of every person who is in any way interested in keeping boilers in safe working order. Written by a foreman boilermaker. Also contains several chapters on oil burning locomotives. Price, 50 cents.

"Locomotive Link Motion." Halsey. Any person who gives a little study to this book ceases to find link motion a puzzle. Explains about valves and valve motion in plain language, easily understood. Price, \$1.00.

RAILWAY AND LOCOMOTIVE ENGINEERING. Bound volumes. \$3.00.

The extensive alterations and additions to the Pennsylvania Union Station at Washington, when completed, will transform the inadequate terminal facilities, from which the road has so long suffered, into one of the finest and best equipped railroad stations in the world, serving all incoming and outgoing trains at Washington. At the inauguration of President Roosevelt last year, while the train service was all that could be expected, the confusion at the station was something that will be long remembered, but, happily, cannot occur again.

## Tate Flexible Staybolt



Strong

Effective

Economical

Flexibility

Durability

Simplicity

Holds firebox sheets securely together, and accommodates itself to the unequal expansion of the plates.

## FLANNERY BOLT COMPANY

PITTSBURG, PA., U. S. A.

Suite 30S, Frick Bldg.

B. E. D. STAFFORD, - - General Manager

Write us for Reference Book



# THE UNION SWITCH & SIGNAL CO.

Consulting and Manufacturing  
Signal Engineers

Automatic Block Signals—Electric  
and Electro-Pneumatic

Interlocking—Electric, Electro-Pneu-  
matic and Mechanical

Electric Train Staff Apparatus

GENERAL OFFICES AND WORKS AT  
SWISSVALE, PA.

**DISTRICT OFFICES:**

New York: 143 Liberty Street

Chicago: Monadnock Block

St. Louis: Frisco Building

**It Ends in Smoke  
BUT IS GOOD WHILE IT LASTS**

If you are a judge  
of cigars try the

## Lordly Edwin

**Conchas Size  
All Havana**

They measure 4½ inches  
over all. Fit any mouth  
and suit all tastes.

We sell them \$5.40 per  
hundred or \$2.70 for box  
containing fifty.

**The Edwin Lord  
Cigar Company**

64-68 W. 125th Street  
NEW YORK

Send for booklet, "Tricks of the Cigar Trade Exposed"

A Bullard wrench is modeled on the principle of the human hand. The makers say—take any cylindrical object like a mailing tube, about an inch and a half in diameter and grasp it in the right hand, thumb down. Hold it firmly with the left hand and turn down with the right. There is a torsional or twisting strain on the tube with no tendency to crush it, so is it with the Bullard wrench. The catalogue which came recently to our office is a most interesting one and is quite artistic, being illustrated by a number of excellent half-tones, and the letterpress describes the wrench plainly and in good style, and the prices are reasonable. They are made by the Bullard Automatic Wrench Company. You can get a catalogue by dropping them a postal card, to Providence, R. I.

**Railroad Improvement.**

The improvement in the physical condition of steam railroads during 1905 has been very marked. The reduction of grades and curves on the chief lines has been prosecuted with vigor. Permanent steel bridges on substantial masonry have replaced many of the old wooden structures. The use of concrete masonry is now almost universal and the results are of the most satisfactory kind. Heavier rails are also taking the place of the older and lighter rails. Probably the most important improvement has been in the rapid adoption of the system of block signalling, which was greatly extended during the year. The duplicate order system of train dispatching has also been widely adopted and has resulted in rendering the possibilities of accident much less than under the single order system.

**Locomotive Tests.**

We have been favored by Mr. Theodore N. Ely, Chief of Motive Power of the Pennsylvania, with a copy of an admirable volume published by that company embodying the results of the work of the testing plant established by them at the St. Louis Exposition and now permanently established at Altoona, Pa., where it is proposed to continue the work begun at St. Louis, and to make further investigation of locomotive performance. Road test and road experience have been the factors heretofore in determining data looking toward locomotive improvement in the past. It is now realized that the locomotive testing plant offers better means of studying the multiplex causes which influence economy and power. In the volume before us there is recorded with accuracy the actual performance of certain typical locomotives and to the designer or constructor of locomotives the book will be of inestimable value and ought to be in the hands of every mechanical engineer

## WASHBURN COMPANY

Minneapolis, Minn.

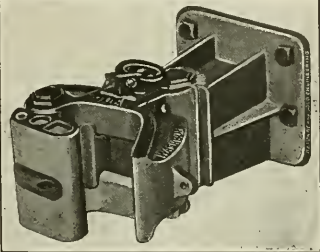

Automatic couplers for freight,  
engine and passenger service.

Draft riggings and buffer attach-  
ments for freight and passenger  
cars.

Special couplers for narrow gauge  
and plantation service a specialty.  
Steel castings of all descriptions.

## Oil Burning in Locomotives

Is described in our new book,  
Care of Locomotive Boilers,

50c. - - This Office

## The Twentieth Century Master Mechanic

Won't use Solid Mandrels.  
Cost too much, take up too  
much room and don't give  
satisfaction.

### Nicholson Expanding Mandrels

Take everything from 1 to 7  
inch holes. Take up little  
room—always ready and  
you can buy four sets for  
the cost of one of the solid  
kind.

### Are You Using Them?

Catalogue tells you  
more about them.

**W. H. Nicholson & Co.**  
Wilkesbarre, Pa.

THIS ILLUSTRATION SHOWS THE FORM OF CONSTRUCTION OF THE

## Dart Patent Union

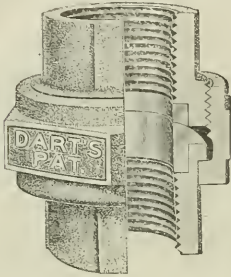

Every feature of construction represents the best points to insure stability and durability. The malleable iron pipe ends and nuts, in combination with bronze metal seats, are as near perfection as is possible to approach, and the sales to date indicate the public approval. There are none so good. For sale by all the principal jobbers in United States, Canada and Europe.

**E. M. Dart Mfg. Co., Providence, R. I.**  
FAIRBANKS CO., SALES AGENTS

# SKAT

Best Hand Soap Known

---

UNEXCELLED for taking the SMUT and GREASE off RAILROAD men.

AGENTS WANTED

An attractive offer awaits the first man in every town who answers this

---

**SKAT MFG. CO.**  
791 Park St. Hartford, Conn.

## Flexible Spout

Vertically in straight line. Also laterally. The latest Improvement to

## Poage Water Columns

**American Valve and Meter Company**  
CINCINNATI, OHIO.  
—SEND FOR CATALOGUE—

engaged in locomotive work. The description of the testing plant is particularly interesting, the designing of which was entrusted to Mr. A. S. Vogt, the accomplished engineer of the Pennsylvania Railroad.

The volume extends to 740 pages, and is profusely illustrated. It may be obtained for \$5.00 on application to Mr. D. S. Newhall, the purchasing agent of the company, Broad Street Station, Philadelphia, Pa. In selling the book at this purely nominal price the P. R. R. have placed an exceedingly valuable reference work within the reach of all who are interested in the important subject of laboratory tests of locomotives.

### New Car Ferry on Lake Ontario.

Port Hope is a town on the Canadian side of Lake Ontario about opposite Rochester, N. Y. The U. S. Consul at that point reports that the Grand Trunk Railway intend to make an important railway center of Port Hope. A company has been formed to operate a car ferry on Lake Ontario, between Port Hope and Charlotte, the port of Rochester, N. Y.

One boat will be put on as soon as it is built and will carry 25 freight cars, and is expected to make one round trip per day, summer and winter. The contract for the boat has been let to the Canadian Ship Building Company, of Toronto, and will be almost a duplicate of the boat now being built for service on Lake Erie. The engines will be of 3,000 h.p., and are designed to drive the boat through ice in winter. The engines are being built by the Great Lakes Engineering Works, of Detroit, Mich.

This project, taken in connection with the fact that the Grand Trunk have been making surveys between Port Hope and Midland, on Georgian Bay, for the purpose of straightening the road and cutting down grades preparatory to double tracking, indicates a very satisfactory increase of business.

The following distances are approximately correct, taking Port Hope for the starting point: Across the lake, thence to New York or Boston, 450 miles. Via the Grand Trunk Railway to Portland, Me., 567 miles. To St. John, N. B., via Montreal, 743 miles. To Halifax, N. S., via Montreal, 1,018 miles.

With the building of the Grand Trunk Pacific, this ferry service will be the connecting link between Boston, New York, Philadelphia and Baltimore and the Pacific Coast, over a new line.

A firm of locomotive builders in Glasgow, Scotland, has recently obtained a contract to build six locomotives for a railway in India. An American locomotive building firm put in a bid but failed to receive the order on account of price being higher.

**The ALDON COMPANY**  
1103 Monadnock Block  
CHICAGO, ILL.

## ALDON Car and Engine Replacer



Save Time, Labor and Damage to Equipment

No Loose Parts to Get Out of Order  
Gradual, Easy Lead to Rails  
A Modern Appliance for Modern Roads

CIRCULAR ON APPLICATION

## Locomotive Engine Running and Management

By Angus Sinclair \$2.00 Best book in print for any railroad man

**ANGUS SINCLAIR COMPANY**  
136 Liberty Street, New York

**A Practically Perfect Portable Pneumatic**

# PUNCH

Stop moving your heavy work to the machine. One Man brings this tool to the work and punches it besides.

Punch Size 3

**SAVES TIME LABOR SPACE**

Leading concerns in all parts of the country use this Punch.

Built in 5 Standard Sizes. Special machines built to order. Write for Catalogue C.

**F. F. SLOCOMB & CO., Builders**  
WILMINGTON, DEL.

# Locomotives, Freight and Passenger Cars

All equipment rebuilt in our Chicago shops, and at Scranton, Pa., in the new "Lackawanna" Shops

## All Kinds of Cars and Engines Ready for Immediate Delivery

RELEASED BY TRUNK LINES

1000-60,000 LBS. CAPACITY REBUILT FLATS AND GONDOLAS  
 2000-50,000 LBS. CAPACITY FLATS, BOX AND GONDOLAS  
 COACHES, COMBINATION AND BAGGAGE CARS  
 FOREIGN SHIPMENTS HAVE PROPER CARE OF  
 EXPERIENCED STAFF

Cache Address  
 "FITZLUTH"

55 AND 70 TONS CONSOLIDATIONS  
 45 AND 50 " 10-WHEELERS  
 40 TO 55 " MOGULS  
 45 TO 50 " PASSENGERS  
 SWITCHERS, FORNEYS AND SHAY ENGINES

**FITZ-HUGH, LUTHER CO. Monadnock Block, CHICAGO**  
 141 BROADWAY NEW YORK      CHEMICAL BLDG. ST. LOUIS      80 ST. FRANCIS XAVIER ST. MONTREAL, CAN.      RIALTO BLDG. SAN FRANCISCO

## World's Fair

St. Louis

FIRST PRIZE FOR

## TOOL STEEL

AWARDED TO

## McInnes Steel Co.

CORRY, PA.

in competition with the best makes in England and Germany. Also manufacturers of all kinds of Tool Steel, Die Blocks, and Steel Forgings.

Write for Prices and Information



**GOLDEN YELLOW CALLA LILY, 5 Bulbs.**  
**50 KINDS FLOWER SEEDS 10c.**  
 Asters, Balsam, Canna, Calliopsis, Nasturtium, Morning Glory, Pansy, Larkspur, Jole's Tears, Poppy, Golden Glow, Snapdragon, Cosmos, Pink, Zinnia, Verbenia, Morning Plant, Sweet Rocket, Primrose, Ice Plant, Petunia, Castor Oil Beans, Portulaca, Candytuft, Sweet Peas.  
**5 CHAMPION BULBS.**  
 The Summer Hyacinth, Golden Lily, Humming Bird, Gladiolus, Giant Tuberose, Baby Breath Oxalis, all this beautiful collection of seeds and bulbs only 10c. in silver or 2c. stamps to pay the cost for packing and postage. Order quick and be sure of this grand offer—only 10 cents.  
 CHARLESTOWN NURSERY, - CHARLESTOWN, MASS.

A pamphlet on four-cylinder balanced compound engines has just been issued by the American Locomotive Company, which contains a paper read before the Railway Club of Pittsburgh, by Mr. F. J. Cole, mechanical engineer. This paper begins with the presentation of the reasons for the interest now taken in the various types of four-cylinder compounds and this is followed by an historical statement of the early stages of development which led up to the four-cylinder compounds of the present day. The author presents diagrams from early patent specifications and he gives dates of what may be called the turning points in the development. A number of engravings are used to illustrate the subject of crank axles, thus graphically recording the forms used and the progress made. Among the illustrations are several showing well known English, French and American four-cylinder compounds, and the Cole system naturally receives prominent mention. This pamphlet, beside being historical, contains quotations and descriptions of the best foreign practice, as well as that of the company with which the author is connected. Copies of this pamphlet, which has been made to conform in style and make up to other publications issued by the company, will be sent to those interested upon application.

In connection with the discussion of affairs in Russia during the last few months, we notice that the word "altruism" is coming much into use. Altruism is an extended form of charity or benevolence that does not begin or end at home. We are rather prejudiced against the word "altruism," but we think the world would be better from the state of being it represents being more widespread.

Fans, blowers and exhausters for heating and ventilating, mechanical draft and other purposes are described in a booklet issued by the Green Fuel Economizer Co., of Matteawan, N. Y. This company has for many years installed fans and exhausters for mechanical draft in connection with the Green Fuel Economizer. They have recently added large shops to their plant in order to handle this branch of the business.

Many of the most valuable inventions ever given to the world brought no patent royalties to the originators. The locomotive provides a good illustration of this truth. The most valuable fuel saving invention put on early locomotives was valve lap. Then came fixed eccentrics, link motion and wheel counterbalance weights. None of these improvements were patented.

## Star Brass Manufacturing Co.

Original and Exclusive Manufacturers of

### "NON-CORROSIVE" STEAM AND AIR GAGES

Extra Heavy Muffled and Open Pop Safety Valves, Chime Whistles, Safety Bulls-Eye Lubricators, Automatic Water Gages, Globe, Angle, Check, Cross and Blow-off Valves.

Main Office and Works

108-114 EAST DEDHAM ST. BOSTON, MASS.

NEW YORK CITY

LONDON, ENG.

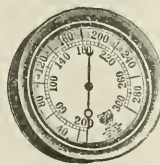

Branches,



**STANDARD MECHANICAL BOOKS  
FOR ROAD AND SHOP MEN  
BY CHAS. McSHANE**

**The  
Locomotive Up to Date**

Price, \$2.50

**New York and  
Westinghouse Air Brakes**

Price, \$1.50

**One Thousand Pointers for  
Machinists and Engineers**

Price, \$1.50

All books bound in fine cloth

AGENTS WANTED everywhere; write for terms and descriptive circulars. Will be sent prepaid to any address upon receipt of price.

**GRIFFIN & WINTERS**  
171 La Salle Street, CHICAGO

**Wm. R. Phelps & Co.**

MANUFACTURING JEWELERS.



High  
Class  
Watches,  
Diamonds,  
and  
other  
Precious  
Stones.

We make a specialty of  
Masonic and all other Emblems.

Diamonds purchased of us at present prices are a good investment. We have a fine line of the best Railroad Watches at rock bottom prices. Jewelry of every description.

**WM. R. PHELPS & CO.**

32<sup>1</sup>/<sub>2</sub> MAIDEN LANE, NEW YORK, N. Y.

**The Last Spike.**

A new book has just come from the pen of Cy Warmen, the railroad man's poet, and author of various railroad stories that could come only from one to the manner trained. Cy went through the hard ordeal for several years of railroad fireman and engineer, gaining thereby the capital of experience that he has fringed with poetic linings, making most attractive literary pictures admired of all lovers of real literature. Mr. Warmen is author of the song, "Sweet Marie." While on his way from the West on a trip to Egypt and the Orient Mr. Warmen stopped in New York for a day or two and was induced to give his song to a music composer for publication. After three months' wandering the poet returned to London and the first news of his song he heard was the street gamins singing it.

**They Needed It.**

Gen. Frederick D. Grant was praising the intelligence of a certain colonel.

"He it is," he said, "of whom they tell the church parade story. His men were drawn up for church parade one Sunday morning, but the church was undergoing repairs and could not accommodate all.

"Sergeant-Major," said the colonel, 'tell all the men who don't want to go to church to fall out on the reverse flank.'

"About 60 per cent. of the men quickly and gladly fell out.

"Now, Sergeant-Major," said the colonel, 'dismiss the men who didn't fall out and march the others into church. They need it most.'

A neat little pamphlet, setting forth the merits of the Harvey Friction draft spring, has just come to our office. It is a nicely illustrated booklet and shows the 6<sup>3</sup>/<sub>4</sub>x8 in. double coiled spring as it comes from the factory. It is applicable to any form of draw gear, new or old, and the main spring is made out of a square bar with the two outer corners cut off so that, in fact, the section of the bar shows five sides. Around the beveled outside edges of the main spring a second one is coiled. The second one is triangular in section and fits close against the first. When taking up shock the main spring is compressed, and as it goes together the bevel edges slide over the bevel edges of the second and thus tend to increase its diameter while it is undergoing compression as well. The result is increasing resistance and increasing friction. The spring has been carefully designed and looks like "business." Its compression capacity is said to be 150,000 lbs., and its release 17,200 lbs. Anything over 152,000 lbs.

makes the spring equivalent to a solid cylinder of steel. Write to the Frost Railway Supply Co., of Detroit, if you would like a look at the kind of spring they make.

The locomotive building industry in Scotland has been very busy during the past year, the North British Locomotive Company having employed 7,716 men, being nearly one-half of the men employed in this branch of engineering in Great Britain.

The indications are that the various locomotive works in America in 1906 will surpass the record of 1905. The record of the Baldwin Works for 1905 and in 1903, will no doubt be considerably surpassed, chiefly by orders from foreign countries.

A movement has been going on for some time among the United Machine Workers of Great Britain and the Society of Amalgamated Engineers with a view to a consolidation of the two bodies. The terms have at last been agreed upon and the membership of the new organization exceeds 100,000.

Information comes from Canada that the Grand Trunk Pacific, with a view of selecting the best route through the Rocky Mountains, has been engaged in surveying the passes. A good many of our legislators have not this year been able to survey any passes, and it is impossible to say for certain what line they may adopt.

**CONTENTS.**

	PAGE.
Air Brake Department.....	121
*Alanche, Fighting.....	127
*Automobiles, Box Car for.....	116
Book Notices:	
Electrical Wiring—Harrison.....	115
Modern Machine Shop Construction—Per- tigo.....	115
*Car, Box, for Automobiles.....	116
*Car Design, Science Applied to.....	126
Car Ferry on Lake Ontario.....	140
*Car Gasoline Inspection, for Railroad.....	124
*Car, Sullivan Side Door.....	126
*Conqueror Sander—Pay and Egao.....	136
*Croshead Jack or Fulcrum.....	134
Editorials:	
Couplers, More Reliable Needed.....	115
Device, Very Ancient (Piston).....	112
Electric and Steam Locomotives.....	114
Electricity vs. Steam.....	114
Marvelous Speed.....	113
Passes, Revenue for Stoppage.....	115
Railroads as Merchants.....	112
Railway Guide, First.....	112
Rational Criticism Made Effective.....	112
Train, President's.....	114
*Fire and Acid, Proof Jacks.....	114
General Correspondence.....	105
Inspection Car, Gasoline, for Railroads.....	124
Locomotive Tests (Book issued by P. R. R.).....	139
Locomotives:	
*Balanced Compound M. K. & T.....	124
*Frisco Ten-Wheeler.....	103
*Geared Locomotive, Tractive Effort, For- mula.....	123
Notes and News, British—F. Sinclair.....	103
Office Receiptable, Handy.....	137
*Oil Pump for Locomotives.....	133
Our Correspondence School.....	117
*Patent Office Department.....	102
Personals.....	129
*Plato Milling Machine—Newton.....	135
*Railway Progress, New South Wales.....	120
*Spike, The Last.....	101
Train Stopping and Heat.....	101
Torque and Power.....	124
*Tractive Effort of a Geared Engine.....	128
*Valves and Valve Motion, Development of— Angus Sinclair.....	108

# Railway and Locomotive Engineering

Copyright by Angus Sinclair Co.—1906

A Practical Journal of Railway Motive Power and Rolling Stock

Vol. XIX.

136 Liberty Street, New York, April, 1906

No. 4

**As It Was Before the Railway.**  
The scene represented on this page is from a photograph taken in the Maritime Alps, and it gives one a good idea

Italian province of Piedmont from France. Probably the highest elevation in the Maritime Alps is about 9,400 ft. On the left of the picture is a zig-

zag road. know that the Alps of this continent, the famous Rocky Mountains, are being constantly explored by railway engineers, guides and daring hunters.



IN THE MARITIME ALPS—SCENE TYPIFYING WHAT A RAILWAY LOCATING ENGINEER MAY ENCOUNTER.

of the kind of country which the railway locating engineer often has to attack. The Maritime Alps is the range which extends from about half way or middle of the Durance river southward to the Mediterranean. It is part of the mountain chain which separates the

zag road. It is one on which horses and vehicles may travel. In fact, the modern motor car, with its tooting horn, has been seen and heard on such roadways as these in various parts of the Alps.

In this connection, it is interesting to

One of them, who is a mountain guide in the employ of a railway company, strange as that may sound, recently discovered a series of caves of magnificent proportions. Mr. C. H. Deutschmann, formerly of Minnesota, now of Revelstoke, B. C., while hunting big game in

the Canadian Rockies, came upon a subterranean grotto, probably the work of an extinct geyser.

The description of what he found was originally told to the Montreal Witness, and is briefly as follows: "The entrance to the caves led down into black darkness, and he had to build ladders down for a distance of 450 ft. before he reached the bottom. There are really seven caves, one on the top of the other, with holes breaking through the floors occasionally. Water pours in from different directions and meets in the bottom cave. Here the rush of water is so swift that a man could not possibly stand up in it, and its terrific roar fills the caves with an awe inspiring sound. The caves are of wonderful beauty, not only because of the pretty colored stalactites and stalagmites and the delicately formed pink and white carbonates of lime on the walls, but also because of their conformation. The entrance is obtained by a natural bridge over a stream, the bridge being some six hundred feet long. Then descent has to be made of a canyon, along the bottom of which is the way to the main cave, four hundred feet below the entrance. Most of the caves are about thirteen feet high and thirty feet wide, but one called the ballroom, with a floor which is flat and suitable for dancing, is 200 ft. long and 130 ft. wide, and some forty to fifty feet high. The extent of the caves is not yet known, as they have not been fully explored. They are situated about thirty-

well known cricket clubs in that city had among their decorations the words, "Well played; 60, not out." The old engine which we illustrate is still at work, and the North Eastern Railway

diagonally from the top of one to the bottom of the other. The cylinders rest directly on the shell of the boiler, which is not covered with any logging. There is a small cab on one side, in which the

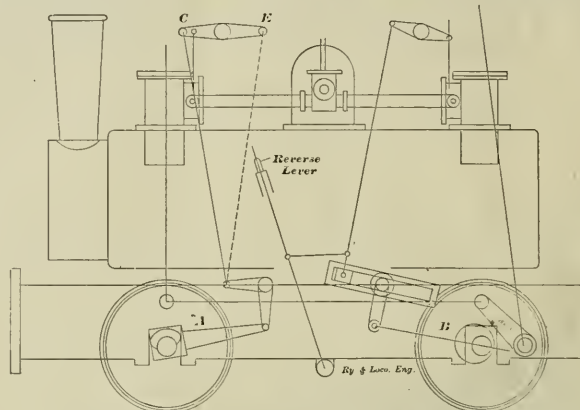

FIG. 1. ORIGINAL AND ALTERED FORM OF VALVE MOTION.

of England might well say of it, as the cricketers did of the Queen, "Well played; 84, not out."

We are indebted to Mr. Wilson Worsdell, chief mechanical engineer of the North Eastern of England, for the photograph, diagrams and information concerning this remarkable engine. Mr. Worsdell is of the opinion that it is the oldest locomotive in the world that is daily under steam, for it was built in

"driver" is evidently allowed to sit down. Our illustration shows him with his hand on the brake apparatus. This is a form used a good deal in the British Isles, and is an upright shaft placed in a hollow stand. The shaft has a screw thread cut on the lower end, upon which a nut works. The nut has two trunions on either side, which take the place of a pin in a lever. The nut can be run up or down the shaft, according to the way the handle is turned, and the nut, although moving the end of a lever, always remains parallel to itself.

The familiar "life guards" are to be seen in front of the leading wheels. These are the vertical metal bars which reach from the buffer beam to very nearly the rail level. They are used throughout the British Isles and on the continent at the present day. The sand box is seen comfortably nestling against the side of the smoke box on the running board level.

The line engraving, Fig. 1, shows the valve gear at A as it was originally built. The motion which actuated the valve was obtained from a cam working in a square box. This motion was conveyed through connecting links and rods to a lever fixed above the steam chest. The valve worked in a box on the slide spindle. The reverse motion was obtained by the driver withdrawing bolt C and moving the rod to other end of lever and replacing the bolt at point marked E. This had to be done separately for each of the cylinders. About the year 1880 the old arrangement was altered. An eccentric sheave was fixed on the axle instead of the cam, and the motion was conveyed through a link, as shown at B.

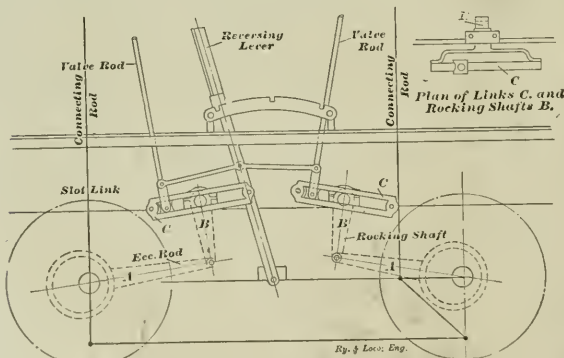

FIG. 2. PRESENT DAY VALVE GEAR OF OLD ENGINE.

five miles from Revelstoke and a mile and a half from the C. P. R. track, from which a rise of 1,900 ft. is made to an elevation of 5,382 ft. above sea level, before the cave entrance is reached."

#### Score: 84 Not Out.

During the Diamond Jubilee of the late Queen Victoria, when all London was decorated with flags, streamers and emblems, the headquarters of one of the

1822 and is now regularly used as part of the motive power equipment in the collieries of Sir Lindsay Wood, who is one of the directors of the North Eastern Railway. The collieries are situated in the county of Durham, at a place called Hetton-le-Hole, in England.

The engine has vertical cylinders 10 $\frac{1}{4}$  ins. in diameter and 24-in. stroke, with crossarms instead of crossheads working in upright guides which are braced

This arrangement is more clearly shown in Fig. 2. The reversing lever was fixed so as to shift the link block in the link. The half-tone illustration exhibits this arrangement also, but the adjacent ends of the links and the bottom of the reverse lever and its ful-

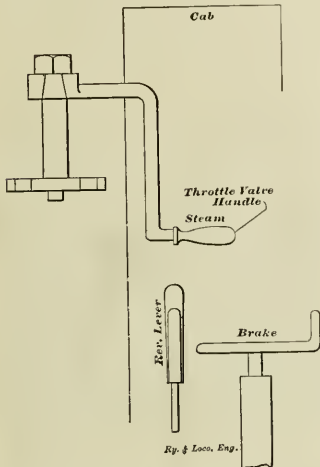

FIG. 3. TRANSVERSE SECTION THROUGH CAB LOOKING FROM FRONT OF OLD ENGINE.

crum are hidden behind a metal plate. In Fig. 1 the old and the new valve arrangements are, for convenience, shown on one diagram, but it must be borne in mind that prior to 1880 the cam and box arrangement for moving the valves was fitted on both axles, but after that date eccentrics and links were used for leading and trailing wheels.

The throttle handle is not shown in the half-tone, but its position is evident from the line drawing, Fig. 3, which we reproduce. The hole cut through the back of the cab can, however, be seen in the photographic reproduction. The throttle valve lever enters the cab near the top, and is secured to a vertical spindle in a valve case on the side of the dome, the old style of butterfly valve being used. The arrangement of levers is shown at *D*, Fig. 3, which is a view looking from front of engine.

The arrangement of the side and connecting rods is interesting. Our illustration shows that the crank pins were placed at quarter turns, the leading pin being in advance of the trailing one. The leading wheel has one pin to which both forward connecting rod and side rod are attached, while the trailing pin is grasped by the rear connecting rod, and a crank arm extends from the pin to the required position for the back end of the side rod. This crank arm is similar to what is used in Wal-

shaert valve gear instead of an eccentric. According to our modern rule, the engine has a calculated tractive effort of about 4,700 lbs. The dimensions of this hardy survivor of pioneer days, as given by the Hetton Coal Company, Ltd., are as follows:

- Diameter of boiler, 4 ft. 4 ins.; length of boiler, 10 ft. 2 ins.
- Length of fire tube, 5 ft.; diameter of fire tube, 2 ft. 1½ ins.
- Length of tubes, 5 ft. 2 ins.; diameter of tubes, 2 ins.
- Number of tubes, 58; length of fire grate, 3 ft. 2 ins.
- Width of fire grate, 2 ft. 6 ins; steam pressure, 80 lbs. per sq. in.
- Diameter of cylinders, 10¼ ins.; height of cylinders above boiler, 1 ft. 6 ins.
- Length of stroke, 2 ft.; depth of piston, 4 ins.
- Diameter of wheels, 3 ft.; diameter of axles, 5 ins.
- Wheel base, 6 ft. 4 ins.; 4 wheels coupled.
- One cylinder to each pair of wheels; length of frames, 12 ft.
- Thickness of frames, 1 in.; boiler fed by one injector and one feed pump.
- Length of tender, 9 ft.; width of tender, 3 ft. 10 ins.
- Diameter of tender wheels, 3 ft.
- Capacity of water tank on tender, 137 Imperial gallons.
- Vertical clearance in axle box guides, 1½ ins.
- Diameter of smoke box, 3 ft. 8 ins.; length of smoke box, 1 ft. 11 ins.
- Coal consumed per day of 11 hours, 10 cwt.
- Size of water tank, 3 ft. 11 ins. long, 3 ft. 3 ins. wide, and 2 ft. 10 ins. high.
- Coal bunker on tender, 4 ft. by 3 ft. 3 ins.
- Height of center of boiler above rail, 5 ft.
- Water in tank will serve 3 hours.

**Odd Units of Measurement.**

In the course of a lecture on "The Metric Fallacy," Mr. F. A. Halsey said: "Even the barleycorn is in wide use to-day, for the difference between the sizes

common unit of land measure to-day is the Spanish vara. In Louisiana, the corresponding unit is the arpent—the old French unit—which, in spite of a century of compulsory laws, is still current in France, and which, Anglicized in pronunciation, is, to-day, the common unit by which land is bought and sold in Louisiana. We have just completed the celebration of the centennial of the cessation of French sovereignty in Louisiana, but the old French unit of land measure survives all the changes of a hundred years, and is still well and hearty, thank you. In the older parts of Philadelphia, 100 ft. and 3 ins. are to-day legally 100 ft., because the surveyors' chain with which the city was laid out was 3 ins. too long. Special tape lines are made for use in Philadelphia on which 100 ft. 3 ins. are graduated as 100 ft.

"The ½ in. United States or Sellers standard screw thread has 13 turns per inch. Mr. Welsh, the original superintendent of the Westinghouse Air Brake Works, for some reason now unknown, objected to an odd numbered thread, and he, therefore, adopted the Sellers standard, except that for the half-inch bolt, he adopted 12 threads instead of 13. This decision has proven to be a mistake and a nuisance, and the company would to-day be very glad to change it, but it finds itself powerless to do so. The immense number of brake equipments which are out all over the world, the constant call for renewals, repairs and extensions makes the simple necessity for continuity paramount above all others. I know of



OLDEST LOCOMOTIVE IN THE WORLD, DAILY UNDER STEAM.

of our shoes is a barleycorn. The State of Texas has been United States soil since 1846, but in those portions of the State which were settled by the Spaniards—how it is in the other portions, I do not know, nor does it matter—but in the portions settled by the Spaniards the

no more significant example than this. This great company finds itself powerless to change the number of threads upon one size of bolt by one turn per inch, but our metric friends tell us that we can change everything and almost without difficulty."

### Hardworked Yard Clerk.

During a discussion on Loading of Locomotives on the Equated Tonnage or Drawbar Pull Basis, at the New York Railroad Club, introduced by Mr. J. M. Daly, of the Illinois Central, Mr. J. M. Daly made the following pertinent remarks about a poorly appreciated clerk: "The question of yard office work has been almost entirely neglected by the railroads. You have doubled the size of your engines, doubled the capacity of your cars and yards, and still the same old yard shanty is there, with the same old forty dollar clerk and no more, but, instead of having one telephone, he has seven or eight, and that yard clerk has an immense amount of work to do, with the poorest kind of facilities, and I believe the further you investigate the tonnage question, the greater will you appreciate the fact that the yard clerk is one of the

refrigerator cars, and any number of telegrams from the traffic department to hold certain revenue loads for orders of the shipper or consignee, to say nothing of looking after per diem and penalty, and delays to cars waiting for billing, and cars on which the bills have been lost or mislaid.

"This yard clerk is furnished with an office about 7x10 ft., and in winter the stove is right alongside of him. He is given no facilities for laying out his work. Conductors coming in throw bills and reports down, sometimes to see how much noise and disturbance they can make, then they go to the bill boxes, pull out their own way-bills, and muss them all up.

"Uncle Sam maintains thousands of local post offices throughout the country, some of which receive ten or twenty letters per day, but he provides suitable

### Snow Plowing with an Ore Car.

The Chicago & North-Western Railway have used an ingenious arrangement this winter in their fight with "the beautiful." They have attached a snow plow made of steel plates to one end of a ballast car, as shown in our illustration, and when weighted with ore or other heavy, rough material, the car has had the necessary weight to make it serviceable against drifts of considerable size.

The point of the plow runs on a slipper, and thus easily slides on the rail when pushing the snow off to either side. The plow, as will be seen, is of the wedge type, and its point can be adjusted to the required height by means of the vertical screw carried on top of the ballast car. The whole arrangement, while temporary as far as attachment is concerned, is yet permanent enough to stand a great deal of rough usage, and when the snow disappears, as it does eventually, before the sun's rays as well as from the front of the plow when in action, the car can be used for the transportation of ballast or freight as was originally intended. We are indebted to Mr. Robert Quayle, the superintendent of motive power and machinery of the C. & N. W., for the blue-print from which our engraving has been made.

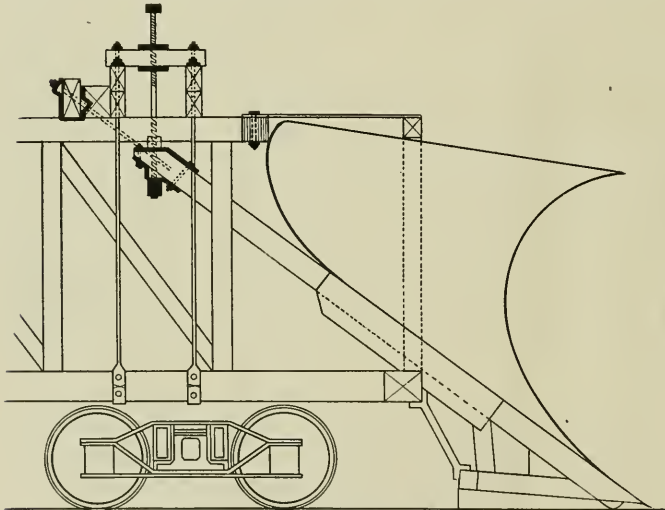

SNOW PLOW ATTACHED TO ORE CAR, C. & N. W.

most valuable men connected with the service and one of the most neglected.

"A good tried-out yard clerk is competent for almost any position on a railroad, for the reason that he must have a remarkable memory, he must have a keen perception to take advantage of conditions as they arise, must be resourceful. For example: When the day man comes on duty in the morning, he finds orders to give this party preference for so many cars, to give that party preference for many cars, and, in fact, he may have preference orders for fifty box cars, with only ten box cars in the yard to apply on the orders; he has telegrams to divert company coal from this to that point; to get special movement on some work material—ties or rails for a given point—to watch for certain furniture and

racks and ample office room and boxes, indexed, into which to place these few letters for quick and ready reference, whereas some yard offices have from five hundred to one thousand way-bills for that many cars at one time, and the cars and contents representing millions of dollars of investment; the loss of one of these way-bills discommodates the shipper or consignee, causes the freight to be delayed, taking up valuable yard space, and still the railroads to-day go on in the same way, with little, if any, facilities in that particular department.

"I trust that the gentleman present who has jurisdiction over that department of the service will not further neglect the yard clerk, but assist him in every possible way and make his burdens lighter than they are at present."

### On Sea and Land.

The Canadian Pacific Railway are doing things on sea and land just now, if reports are true. The company recently notified the Dominion government that their two new steel steamships for the North Atlantic trade, named, respectively, the Empress of Britain and the Empress of Ireland, now being built on the Clyde, will be the fastest ships on the St. Lawrence route, and on this they base their claim that the Canadian mail should be carried by the fastest two ships of the Allen Line and the fastest two of the C. P. R. It is understood, however, that the Allens do not take kindly to the proposition.

Reports emanating from Winnipeg say that the British government have decided to test the resources of Canadian Pacific in a very severe and practical manner. In consequence of their alliance with Japan the Imperial authorities desire to demonstrate the feasibility of transporting, on short notice, 10,000 sailors and marines from Great Britain to Queen Charlotte Island, on the Pacific coast. To do this steamship travel on both oceans and a transcontinental journey will be involved. The C. P. R. will have to carry the men, the necessary camp equipment and the baggage and stores, and will have to feed the men on the way. Perhaps the water part of the program will also be carried out by



the railway company, as they own a magnificent fleet of ships. If successfully accomplished it will be a practical object lesson in transportation, and will be an achievement which must call for a high degree of executive ability, management and railroad operation.

The C. P. R. have a corps of engineers out on a survey in the Rockies for the purpose of constructing a loop which will do away with the 4½ per cent. grade

was ignorant of the state of affairs. A towerman, however, took in the situation and wired ahead of the train for the track to be kept clear. The fireman worked away and the train kept on going, but, fortunately, nothing got in its way. The conductor was at length made to realize that there must be something wrong, and went ahead over the cars, and on reaching the engine quickly shut off steam and applied the brakes.

bar of iron across the rails. An iron track gauge, clean at the points of contact, or, indeed, any piece of bright metal which has a low resistance, would produce the desired result.

**Fireman Grabbed Flying Eagle.**

The fireman and engineer who took the Rocky Mountain Limited out of Denver one morning last month, captured an immense American eagle as it



MANCHESTER LOCOMOTIVE WORKS IN THE EARLY DAYS OF LOCOMOTIVE BUILDING.

between Hector and Field, B. C. The contemplated loop will be about 20 miles in length and it is estimated that it will cost approximately \$60,000 a mile.

**Difficult to Warn.**

A distressing accident recently occurred on one of the leading railroads running between Buffalo and New York. A freight train proceeding at a fairly high rate of speed was naturally observed by persons living near the right

The engineer may have met death while leaning far out of the cab window, by being struck by some object close to the track. Whatever was the cause, the separation of engineer and fireman in such a case as this emphasizes the advantage which would be possessed by some form of automatic stop signal, which those in advance of the train could have set at danger, and so have stopped the train when warned by the towerman.

was flying in the air. The experience is probably unique in railroading.

The unfortunate king of birds will spend the remainder of his days in satiating the wondering gaze of the crowds at City Park. The eagle measures 7 ft. 4 ins. from tip to tip.

It was about 1 o'clock Saturday afternoon when nearly at Limon that the engine crew noticed the bird flying low and straight ahead of the train. The train was then traveling at from sixty

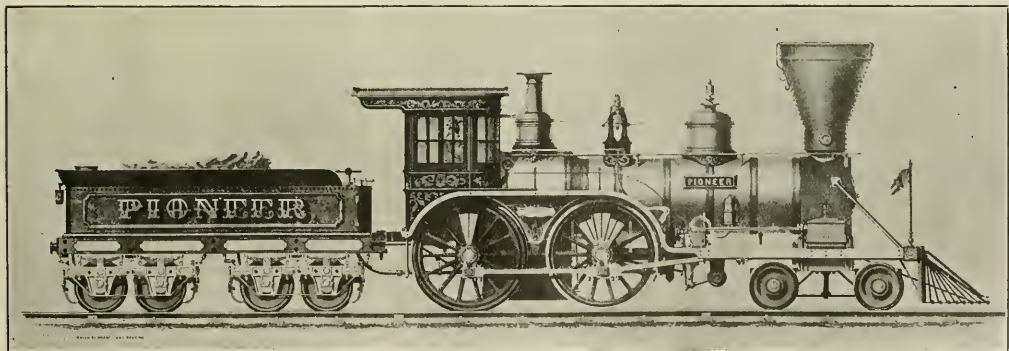

AN EARLY AMERICAN TYPE ENGINE BUILT AT THE MANCHESTER LOCOMOTIVE WORKS.

of way and on the streets of a town through which the train passed. These people were horrified to see the lifeless body of the engineer hanging far out of the cab window.

The train passed too quickly for them to make any effective effort to warn the train crew, and as the engine was one with a centrally placed cab, the fireman

The short circuiting of the track current such as is used where automatic block signals are installed, would put the nearest signal situated between the short circuit point and the approaching train in the stop position. This would operate the automatic trip if there was one. Short circuiting can be done by placing a hand car on the track or by laying a

to sixty-five miles an hour, and if it did not change its course it was evident that the eagle would be overtaken. The bird was on the left side and as the engine flashed by the fireman reached out and grabbed the bird by a leg and pulled it into the cab. With the aid of the engineer the big fellow was downed and tied, but it made quite a fight.

### Patent Office Department.

A notable feature of the bulky reports of the Patent Office Department this year is the devices used on locomotives with a view to economize fuel. The degree of perfection to which the construction of the locomotive has attained has apparently left little to be improved except matters of detail, and the minds of the inventors seem to run in channels where the important element of cost may be lessened. There are a few things in the patent reports which, like the poor, we have always with us. The car coupler seems to run a race with the non-refillable bottle, and the end is not yet.

We select out of a host of meritorious contrivances a few of the most notable.

#### JOURNAL LUBRICATOR.

A device for lubricating journals has been invented and patented by Mr. Austin Berry, Ottawa, Canada, the contrivance consisting of a pin extending from the end of the journal, an arm loosely supported on the pin, a shaft suspended on the arm, a lubricating wheel carried on a sleeve attached to the suspended shaft, and gearing between the sleeve and the pin extending from the journal. When the journal is in motion the lubricating wheel constantly supplies the lubricant to the under side of the journal.

#### SUPERHEATER.

A new form of superheating apparatus has been designed and patented by Mr. William Platz, Weinheim, Germany. The annexed illustration shows that the device is located in the smoke box of a fire tube boiler, the superheater tubes being set at right angles to the fire tubes, the diameter of the superheater tubes being much less than the

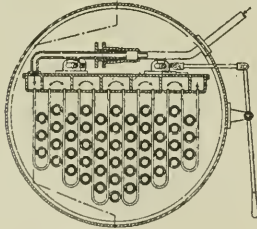

NEW SUPERHEATER.

diameter of the fire tubes, and the superheater tubes being arranged so as not entirely to cover the openings in the ends of the fire tubes. There is also means for moving the superheater tubes transversely of the boiler.

#### CAR REPLACER.

A car replacer has been patented by Mr. W. P. Byrd, Baltimore, Md., comprising a metallic block provided with oppositely inclined sides provided with grooves and a rotary head between the upper ends of the sides and the bottom

of the block having an inclined surface along one edge with a groove extending longitudinally near the inclined bottom surface, the inclined surfaces having arms or prongs which diverge as they recede from the head.

#### SAFETY DEVICE.

Mr. Edmund B. Powers, Brooklyn, N. Y., has invented and patented a safety device for railway service, which provides means for automatically displaying signals in the cab of a moving locomotive informing the engineer and at the same time automatically applying the brakes. The signals are operated by vanes similar to semaphore arms placed near the track and arranged so as to be struck by an extended arm on the locomotive. The contact of the arm and vane causes a red and green light to be displayed according to which vane has been extended, and also actuates a

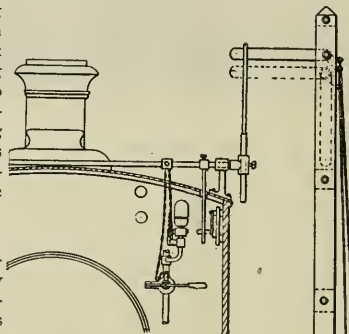

STOP SIGNAL DEVICE.

whistle besides applying the brakes. The accompanying illustration shows the semaphores and also the apparatus attached to the cab of an ordinary locomotive. The patent is now owned by the Railway Cab Signal and Equipment Company, of Portland, Me. The patent number is 748,649.

#### LOCOMOTIVE.

Mr. C. Hagans, Erfurt, Germany, has secured a patent for an improved locomotive, the original claim embracing means for laterally adjusting a driving or driven axle, comprising a laterally adjustable hollow end axle, a core axie slidably adaptable to the hollow axle, and means for transferring the movement of the hollow end axle to the driving or driven locomotive axle, and for driving the core axle. The combination is claimed to ensure the avoidance of rail jumping by heavy freight engines not furnished with front or rear trucks.

#### BRAKE-SHOE.

Mr. Joseph D. Gallagher, Glenridge, N. J., has patented a brake-shoe comprising a body with a central attaching lug, and a lug at each end of the body,

and intermediate lugs between the end and center lugs, the whole being attached with a key sliding readily into the keyway from the upper end of the

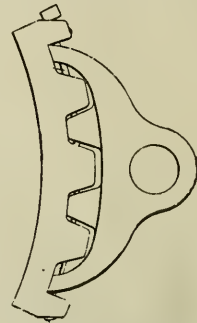

IMPROVED BRAKE-SHOE.

shoe and holding the shoe in place. The shoe is readily attached or detached.

#### GASKET.

Mr. J. W. Guillott, Chicago, Ill., has patented a corrugated metallic gasket having concentric reinforcements surrounding its inner and outer peripheries, the outer ring being of less thickness than the inner ring, the combination forming a durable steamtight disk.

#### BLOCK SIGNAL SYSTEM.

An elaborate new and improved block signal system has been invented and patented by Mr. T. Silvene, Victoria, Canada, which by an intricate but perfectly arranged system of mechanical appliances not only gives warning to trains approaching each other on the same track but by automatic devices applies the brakes and brings the trains to a full stop before a collision can occur. Five pages of drawings are used in the specifications illustrating the mechanism, which embraces almost every device known to railroad signaling, from semaphore arms to trolley brushes. The element of danger from front or rear end collisions would be entirely eliminated with this apparatus in operation, if the claims, which are evidently substantiated by full details, are in proper position. The apparatus also provides for the contingency of false alarms. The patent is No. 777,353.

#### JOURNAL BOX LID.

An improved journal box lid has been designed and patented by Mr. A. Lipschutz, St. Louis, Mo. The claims embrace a combination with a journal box provided, with a lid for opening and a spring carried by the lid and bearing at one end against the box, while the other end of the spring forms a lock engaging with the box to hold the lid in position, and a stop for the spring adjacent to the lock.

**PISTON ROD PACKING.**

Mr. P. H. White, Pittsburgh, Pa., has patented a new device for packing piston rods. The claims embrace a pair of metal sleeve members, semi-circular in form, which clasp the piston rod, and are fitted with laterally engaging tongues. Around this metal sleeve a soft packing is held in place by a follower ring engaged in the stuffing box by a gland in the usual way. The device is claimed to combine the qualities of absolute tightness and durability.

**STEAM BOILER FURNACE.**

Mr. W. R. Hampden, Kansas City, Mo., has patented a steam boiler furnace adapted for locomotive or other engines, the chief new features of which are a system of transverse water chambers situated in the fire box, enveloped on all sides by the water in the boiler. Special air jet orifices are constructed to open into the enveloping chamber. The device is said to effect a considerable saving of fuel.

The invention so much admired when once found created surprise that such

**Balanced Compound, N. C. & St. L.**  
The Nashville, Chattanooga & St. Louis Railroad recently placed an order

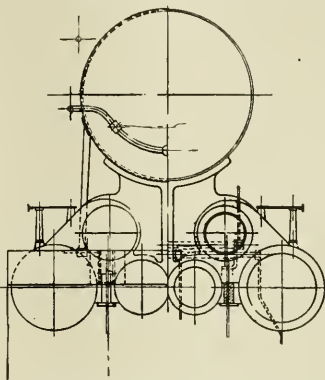

ARRANGEMENT OF CYLINDERS AND VALVE CHAMBER, N. C. & ST. L. COMPOUND.

with the Baldwin Locomotive Works for three engines of the ten-wheel type, to be used in passenger service. They are balanced compounds, and the photograph

centers of the cylinders, and is located above the frames. This makes the cylinder and valve chamber casting on one side all one piece, and the design is economical of space. The pistons all drive on the leading wheels and axle and the counterbalance on this pair of wheels is arranged in accordance with that circumstance. The connecting rod is necessarily short, and it is attached to the crank pin on the outer side of the parallel rods. The crosshead is of the alligator type and the top guide is notched so that neither of the upper edges are exposed, so that the lodgment of grit or dirt between crosshead and guide cannot take place.

The valve gear is indirect, and on account of the fact that the leading axle is cranked the eccentrics are carried on the second or middle axle of the engine. The driving wheels, all of which are flanged, are equally spaced, being 72 ins. apart, and the truck wheels have a spread of 78 ins. The calculated tractive power of the engine is about 29,200 lbs., and as the weight on the drivers

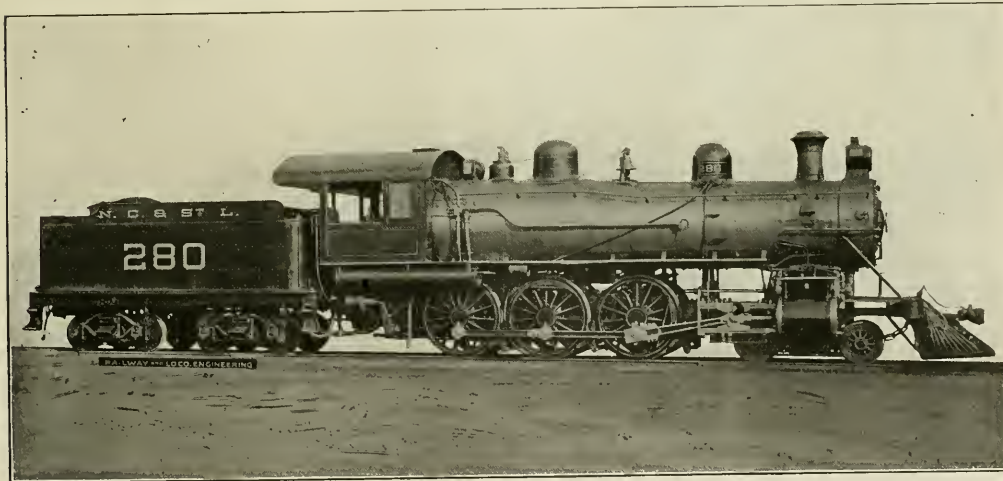

FOUR-CYLINDER BALANCED COMPOUND, N. C. & ST. L. TEN-WHEELER.

F. H. Scheffer, Supt. of Machinery.

Baldwin Locomotive Works, Builders.

a simple thing should have been so long unfound. Simplicity has been the leading element in the most valuable inventions, yet it required a touch of genius to conceive a simple thing with so many possibilities.

The new Grand Trunk roundhouse and yards at Mimico, near Toronto, Ont., were opened in the early part of January. The roundhouse has accommodation for 27 engines, and the north and south yards contain 14 miles of sidings.

from which our illustration was made was taken of the first of the three. It so happened that it was exactly the 27,000th engine turned out of the famous Philadelphia works since they began building locomotives.

The cylinders are 16 and 27x26 ins., and the diameter of the driving wheels is 66 ins. The low pressure cylinders are outside and the high pressure are inside, all arranged with their centers in the same horizontal plane. The piston valve, which has a diameter of 15 ins., is placed between and above the

is 133,920 lbs., it follows that the ratio of adhesive weight to tractive power is as 1 is to 4.5.

The boiler is a wagon-top one with a first course diameter of 64 ins. The smoke box is jacketed uniformly with the boiler, which gives the engine a neatly finished appearance. The tubes, of which there are 256, are each 17 ft. long, and the heating surface they give amounts to 2,550 sq. ft. The fire box gives 185, which brings the total heating surface up to 2,735 sq. ft. A square whose side measures a little over 52 ft.

would give the same area as that of the heating surface of this engine.

The boiler at the dome course is 70 ins. diameter, and as the bottom is level, the gusset sheet gives a rise of about 6 ins. The crown sheet has a slight rise toward the front and the steam and water space above it is in the neighborhood of 22 ins. The back sheet slopes forward about 22 ins. from the perpendicular. The grates are level all but a short distance at the front, and give an area of 34.8 sq. ft.

The tender is carried on two arch bar trucks, and has the usual steel channel frame. The water capacity of the tank is 5,000 U. S. gallons, and it is made on the U-shaped plan. The weight of engine alone in working order is 181,380 lbs., and with the tender the total weight is about 280,000 lbs. A few of the leading dimensions are given for reference:

Boiler—Thickness of sheets, 11/16 in. and 3/4 in.; staying, radial.  
Fire Box—Material, steel; length, 120 ins.;

early last month, Albert French, the engineer, was leaning limp and partly unconscious in the cab of the engine, his hand feebly grasping the throttle lever in an evident effort to shut off steam. The train was within a mile of the station when the fireman noticed that it did not slow down. He walked along the running board to the cab and found that a great rock had rolled down the hillside and had broken through the roof of the cab and had crushed the head of the engineer. The fireman stopped the train. Engineer French never spoke, and died an hour after. A tragic occurrence like this recalls the familiar lines of Pope, which may truthfully be applied to the dead engineer. He was indeed "in death a hero as in life a friend."

#### Pennsylvania Relief Valve.

Our illustration shows the general arrangement of piston and relief valves as used on the Pennsylvania System.

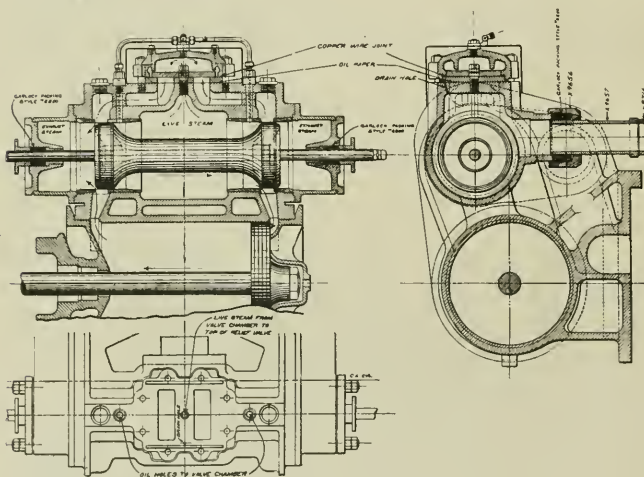

PENNSYLVANIA CYLINDER RELIEF VALVE.

width, 43 1/4 ins.; depth, front, 7 5/8 ins.; back, 6 3/4 ins.; thickness of sheets, sides, 3/8 in.; back, 3/4 in.; crown, 7/16 in.; tube, 1/2 in.; water space, front, 4 ins.; sides, 3 ins.; back, 3 ins.; tubes, wire gauge, No. 11; diameter, 2 1/4 ins.

Driving Wheels—Journals, front, 10 ins. x 10 1/2 ins.; others, 9 ins. x 12 ins. Engine truck wheels—Front, diameter, 30 ins.; journals, 5 1/2 ins. x 12 ins. Wheel base—Driving, 12 ft.; total engine, 26 ft.; total engine and tender, 55 ft. 2 ins.

Weight—On driving wheels, 133,920 lbs.; on truck, front, 47,460 lbs.

Tender—Wheel diameter, 33 ins.; journals, 5 ins. x 9 ins.

#### The Sudden Call.

While two hundred and fifty passengers sat contentedly in their seats on a Baltimore & Ohio express train running over forty miles an hour, one evening

The main valves are inside admission, and in the valve chamber or steam chest there are two ports corresponding to the steam ways of the cylinder, and they are placed precisely opposite the steam ways and are directly above them and the openings are exactly alike and equal in area.

This arrangement is made so that when the steam port of the cylinder is open the relief port above is also open and when one is closed the other is closed. The two relief ports run up and would meet in a single chamber only that a flat plate is placed on top which closes them both. This flat plate is capable of a slight vertical motion and whenever it lifts from its seat there is unbroken communication between one end of the cylinder and the other.

In order to keep this flat plate down normally and yet permit it to lift when occasion requires, live steam is introduced into the cavity above the flat plate through a hollow plug, which passes up through its center, and this plug acts as a guide for the flat plate to move up and down on.

It is obvious that if at any time the compression caused by the imprisoning of steam in the cylinder raises the pressure above that of the live steam in the valve chamber, the flat plate will lift and afford a way of escape for steam to reach the exhaust side of the piston. Water in the cylinder would be forced out through these passages and would lift the flat plate against live steam pressure and readily pass out without causing damage to any part of the mechanism. The design is simple and compact, and has few parts, and what there is of them are easily got at. The device has given every satisfaction and has been used on the lines east and west of Pittsburgh. It was designed by Mr. A. S. Vogt, the mechanical engineer of the Pennsylvania system.

#### Daisies Follow Railways.

The old English expression, "The flag follows the trade," had its origin in the days when "the nation of shopkeepers" went out into the uttermost parts of the earth for the purpose, not of military conquest, but in order to trade, and the following of the flag consisted in the fact that the protection of the home government was always accorded to British merchants in foreign countries and often the land which they occupied eventually came under the flag. The heading of this paragraph is taken from "Tales and Talk," and was no doubt suggested by the old expression which we have quoted. T. A. T. says:

"Buttercups and daisies follow railways the world over," said an engineer. "In India, in Central Asia, in Brazil, the parallel rails continually run between meadows white and yellow with home flowers.

"In the construction of practically all foreign railways English or Scotch engineers and contractors have a hand. These men know that good home grass is the best thing for holding together the earth on embankments. Grass is tough and lasting; it strikes roots so easily that it practically cements the most flimsy earthworks.

"So grass seed from home is sown on railway embankments all over the world by the home engineers, helping to build them, and thus, in the most tropical places among gorgeous orchids and palms and giant cacti you will see mile after mile of wholesome, clean home grass, studded with white daisies and yellow buttercups."

# General Correspondence.

## Cause of Engines Slipping.

Editor:

In all friendliness and good will, I still must differ with you in regard to my letter in your February issue on slipping of wheels.

We are told that the surface of iron or steel may be polished ever so bright and smooth, and it still would show under a powerful microscope to be made up of tiny hollows and projections, and that what we know as "friction" between two surfaces, moving one over the other, is caused by the projecting points on one falling into the hollows of the other.

Now, it is evident that when we wish to move one surface over the other, or, rather, when one does move over the other, the two surfaces pressed together must separate enough to allow the projections on the face of one to rise from its bed, which is the hollows, and slide over the projecting points of the other, and we know that it does so.

We know also that if the two surfaces are pressed together with sufficient force they will be locked so tightly that they can't move, as, for instance, a brake shoe applied tight enough to slide the wheel, in which case the surface of the shoe and the projections thereon, have become firmly locked in the hollows upon the face of the wheel; so firmly, in fact, that they cannot separate or rise enough to let one slip over the other. This also applies to the surface of the wheel and rail.

Before the wheel can slip upon the rail it must rise enough to allow the tiny projections upon the face of one to move over the others, and it does so, although not perceptible to the eye. Like the pressure upon the brake shoe, the more weight we place upon the driving wheels the firmer the hold of the wheel upon the rail, while on the other hand, anything which tends to reduce the weight or pressure of the wheels upon the rail allows them to slip more readily. It was this I had in mind when I wrote the letter in February.

I did not intend to liken the lifting effort spoken of to that of communication to a jack or a toggle joint, in which the wheel would be lifted bodily from the rail. I intended to show that with a large wheel and short stroke there is a loss in tractive effort, and that more power is exerted against the frame at the box to lift than to rotate the wheel.

It is a question of two opposite forces, the frame pulling against the pin, and the longer the line between pin and axle

the easier one overcomes the other, while the shorter we make this line, the harder it is for one to overcome the other, and when power enough is applied to do it it goes with a jerk and kicks up against weight on wheels. If it was only a question of the tractive power being unable to overcome the inertia of the load, or of a low ratio of adhesive power, then slipping would be just as apt to commence in one position as another, but it has been my experience and observation that it will be on the lower forward eighth that an engine will start slipping, and there must be a reason for it.

As I stated in my former letter, an engine will always start to slip on the

Now, the one with the larger wheels will not have as great a tractive power as the other, but will have a higher ratio of adhesive power than the other, and consequently should be able to make a greater effort, or should work nearer to the limit without slipping, but if we load the first engine up to about the limit and then hook the second engine on in its place, we find that while there has been a gain in adhesive power, there has been a loss in tractive power, and unable to do the work of the other it will slip, for all it has a greater ratio of adhesive power, and it is owing to the fact that there is a greater lifting effort exerted upon the line between pin and axle.



JURA-SIMPLON RAILWAY—SWITZERLAND, ENGINE WITH SNOW FLANGES IN FRONT OF TRUCK.

lower forward eighth, with right side leading. Why is this? Because the power on left side is dying, and right side is beginning to live, and the power at this point is being applied under the weight on wheels, and at about the eighth. It, as you may say, kicks up against the springs which, as we know, are compressible, and allows wheel to rise enough, or separate from rail enough, to slip, and by the time that right side has reached lower back eighth the left side is on lower forward eighth, and gets in its kick on that side. This is done regardless of size of wheels, but just the same with a big wheel, and short stroke, the line between pin and axle is the shorter, and we lose in tractive effort but gain in lifting effort.

To make it clearer, suppose we take two engines of the same size and build, same length of stroke, and put larger wheels upon one than the other.

That is my belief; and now for the remedy. Well, there is no cure but a help, and that is a longer stroke than now used.

For freight engines now used, the wheel should be at least 60 ins., and the stroke as long as possible, and the right reduction in diameter of cylinder.

An engine built along these lines should be more economical in using steam; in fact, should do more work with less steam than an engine with same weight on drivers with short stroke and a 60 in. wheel. It perhaps would be harder on guides and crosshead, and while an engine so designed would have a higher rate of piston speed, the wear of cylinders with long stroke in freight service would not be as much per month or year as it is with the short stroke in passenger service, and the long stroke engine could work nearer the maximum effort without slipping.

E. C. ALLEN.

**Electric vs. Steam Locomotive.***Editor:*

I should like to know why was a good rail and fair weather selected for the recent test between the General Electric Co.'s electric locomotive, built for the N. Y. C. R. R. terminal, and the steam locomotive? Was it the General Electric Co. that conducted this test?

Could you "pick the winner" under the three following conditions, viz.: Steep grade with slippery rail; severe snowstorm; heavy sleetstorm? Was it a test with or for a purpose?

New York.

W. A. E.

**One-Piece Steel Crosshead.***Editor:*

I am forwarding you herewith blueprint of our cast steel crosshead which we are using on our class 10-34-E 70-ton engines. The feature which I think

out the wrist pin hole to proper size, this hole being cored out to as near the correct size as possible. We find this is a very cheap and compact arrangement, doing away with gibs and loose side plates, together with the expense of fitting same.

We have had an epidemic of broken gibs heretofore, which usually meant bent piston rods and broken back cylinder heads, but the steel casting does away with all possibility of engine failure in this direction.

H. C. SHIELDS,  
Superintendent,

Lehigh & New England Railroad.  
Pen Argyl, Pa.

**Burning Natural Gas.***Editor:*

Having, through the courtesy of one of your subscribers, had the opportunity of reading an article in your val-

burners as some of our friends to the south, yet we have some of the best burners made by them, besides our own make, which, I am pleased to state, takes the bun when it comes down to actual test. The home burner, invented and built by a resident of this city, beat the foreigner in a 24-hour meter test by 5,000 cu. ft. I am speaking of the two best burners. We have tried others, but they were not in it at all.

Mr. Whitham next says that as good economy is made with a blue as with a white or straw flame, and no better, and that greater capacity may be made with a straw-white than with a blue flame. Now this statement, to my mind, shows a lack of knowledge on the combustion of natural gas, for any one who has burned natural gas in the house or under the steam boiler knows that unless you have the proper mixture of air to burn the gas it will surely make a very dirty fuel; it will make soot worse than coal or other fuels and in a much shorter time.

I have found in my experience through burning it under return flue locomotive and vertical boilers, as well as in stoves, etc., that the blue flame is a sure indication of perfect combustion. I also found that if the gas was heated previous to passing into burners it made a much hotter fire, and greater incandescence in a gas lamp.

In comparing the efficiency of natural gas with coal, I do not think there is any question when the matter of cost and labor is taken into consideration. We have, on the one hand, the best coal. Now, any one who has had to pay for coal, commencing with the unloading of same, to the taking away of the ashes, knows that it is a very expensive item. Then there is the continual opening and closing of fire doors and consequent cooling of boiler plates, causing more or less damage to boiler tubes and plates, besides a variable steam pressure, etc.

On the other hand we have natural gas, which, if properly burned, gives a steady and even temperature; no soot, no cooling down of boiler plates; constant and even steam pressure; no ashes to carry out, no repairs to grates and brick walls, less repairs to boiler; clean and tidy fire room; less labor required; and a good many other advantages, too numerous to mention.

I cannot agree with Mr. Whitham when he claims that one ton of semi-bituminous coal is equal to 28,700 ft. of natural gas. We have tested it under boilers, and find that it only takes 26,000 ft. of natural gas to one ton of our best steam coal. He also states that, taking coal at \$2.00 per ton of 2,240 lbs., and considering the labor saved by gas, gas ought to sell for 10 cents. I don't think I should like to work for Mr. Whitham for about 87 cents a day, when I should

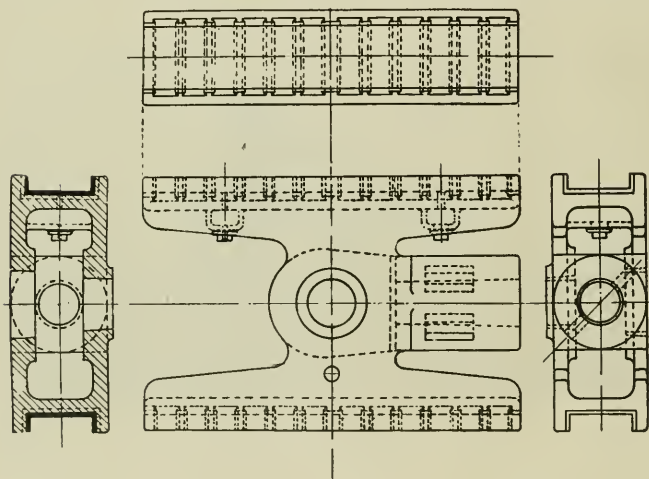

CORED STEEL CROSSHEAD, L. & N. E.

commendable is the fact that the crosshead is made in one piece, and the amount of machine work required to finish it is very small compared with the made-up types of alligator crosshead. You will note that we have cored the upper and lower wearing faces, also the side plates, and are filling them with block tin. This part of the casting we do not machine, the machining at this point being confined exclusively to the soft metal, which makes a very short and cheap operation. You will also note that we have cored in the crosshead keyway, and by changing these cores to right and left the one pattern does for both sides. We get very good results from the core work, and do what little finishing that is necessary by filing. You can readily see that the machine work comprises boring out of the piston rod fit and boring

uable journal on burning natural gas, which was a paper read by Mr. Whitham before the American Society of Mechanical Engineers, and being interested in this very valuable product, I beg leave to differ somewhat with Mr. Whitham on certain statements he made with reference to the efficiency of natural gas compared to coal.

In the first place, he states that certain records of burners are impossible. I shall not dispute that, but when he says there is little advantage possessed by one burner over another, he is strictly out of it, for the writer is in a position to prove to him that there is a very marked difference in the efficiency of the different makes of gas burners, which I have demonstrated by actual tests right here in this city.

While we may not have had quite as much experience in the selection of

have to unload coal, wheel it to the boilers, bake myself every 20 minutes or oftener, shake down fires, rake out hot ashes, etc., etc. In Medicine Hat, where the writer lives, we pay, when we have to burn coal, \$4.75, and we sell natural gas for 5 cents per thousand cubic feet to those using ten thousand feet, or over, per day, and all that you need is your engineer to strike a match and you have your firing done for the day in a moment. Well, Mr. Editor, I would like to continue this long letter, but I have overstepped the mark now, but trust you will let me down light on this my first appearance as a correspondent, and hope to hear further on this gas subject from Mr. Whitham or others, for I am of the opinion that we have lots to learn yet in the use of natural gas.

R. S. WINTER,  
Gas Inspector, C. P. Ry.  
Medicine Hat, Alta.

### Filling Boiler While Being Towed.

Editor:

I noticed in the January number of RAILWAY AND LOCOMOTIVE ENGINEERING the question asked and answered, Can a boiler be filled through injector while engine is being towed by another engine? If an engine can be filled by the method given there I would like to see it done. I have filled several, both simple and compound, and was laughed at several years ago when I asked the dispatcher to have my engine pulled a short distance to fill it, and I was also laughed at by an old engineer.

One very important thing is left out in the answer given, that makes it impossible to do the work, and if the engine is placed in proper condition you can fill the boiler more rapidly than with steam and at 10 miles per hour speed. Will someone tell what is omitted in the answer?

This is my first attempt to write for a mechanical paper, and this may find the "scrap pile." I have run a V-hook motion with independent and variable cut-off and all styles of compounds built in the U. S. except the balanced compound. I have read many questions, especially on "V-hooks," in mechanical periodicals, some of which must have been taken from books and not from actual experience with this class of engine. If this goes to press I may come again.

A. J. H.  
Mena, Ark.

### Decline of Mechanical Skill?

Editor:

I have read with considerable interest the letter of "Reader" in your February number deploring the decline of mechanical skill, and while I admit that the skill of the average mechanic has declined, I strongly disagree as to the cause.

"Reader" claims that the most prominent reason has been the influences of trade unionism, and believes matters would be improved by allowing the employers to employ as many apprentices as desired.

If your correspondent will investigate the policy of the unions on the apprentice question, which can be readily seen by an examination of the agreements between the unions and the larger corporations (notably the railways), and which are published in all the journals, he will readily admit that they have done more toward advancing the standard of apprentices than all other interests combined.

The percentage of apprentices has been regulated, and if the employers are unable to teach and make mechanics of the number now employed, how much worse would be their condition if double the number were employed?

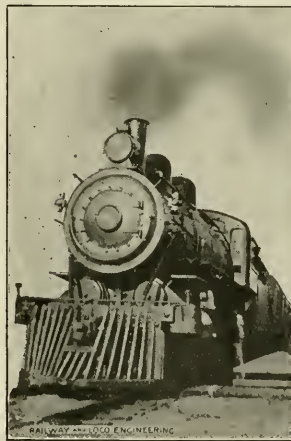

WAITING FOR ORDERS.

A number of the unions admit the boys as members, and strict laws have been laid down to prevent boys leaving their employers before the expiration of their apprenticeship.

The statement that boys are a loss to the employers will hardly stand, in view of the fact that the large firms are employing them for every possible position.

The real and only reason for the passing of the "all round mechanic" is the tendency of the age to specialization. This is especially noticeable in the larger shops, where the apprentices have to fight continually in order to get the necessary experience.

The majority of "all round men" of to-day are those whose apprenticeship has been served in some small shop in the back woods where they were compelled to do anything and everything connected with the trade.

In proof of the above, I would refer "Reader" to the article by Mr. James Kennedy in the February issue entitled "A Glance at Baldwin's." Mr. Kennedy says, in part: Here "specialization appears to have reached the climax." "There is the same piece of work he has been doing over and over again year after year. What will become of him if he leaves Baldwin's?"

Vancouver, B. C.

JUSTICE.

### Negligence Claims Another.

Editor:

On February 2, at Eldorado, Ill., Fireman Munroe, on Cairo division of the Big Four, was killed by jumping from his engine.

His train was running at high speed, and was passing an opposing train which was on the siding. The train on the siding was in to clear, and the headlight was not covered, as rules require.

Munroe had been apparently in a doze, and when he awoke the headlight of the engine on siding flashed in his face, and his first thought seems to have been that his engine was about to collide with the engine of the opposing train, and he jumped at once, landing against the side of a shallow cut, which threw him back under the train, and he was literally ground to pieces. The coroner's jury rendered a verdict that "death was due to his own carelessness" and exonerated all the living from blame.

No one has been suspended or reprimanded. The headlight of the engine on siding should have been covered at once when train was in to clear, and it is quite evident that neglect to do this was the indirect cause of this man's death. This is not a plea for the chronic dozer, but when a fireman is held on the road anywhere from 18 to 36 or 40 hours, one cannot afford to judge too harshly. It seems that human life is nothing to some corporations. Had this violation of an important rule resulted in derailing a car or smashing a pilot, the engine crew responsible would now be looking for jobs.

WM. WESTERFIELD.

Mt. Carmel, Ill.

### Surrender of Patent.

The Pennsylvania Railroad Company has issued a special notice, being an extract from the official Gazette of the United States Patent Office, dedicating to the public the invention secured by letters patent to Mr. Wm. F. Kiesel, Jr., of Altoona, Pa., for improvements in tank cars, the company being desirous that the invention may be freely made and used within the United States and its territories, and without any compensation to the company.

**Development of Valve and Valve Motion.\***

BY ANGUS SINCLAIR.  
PART TWO.

TREND OF AMERICAN INVENTION.

In a country where there was the amount of unrestrained ingenuity prevailing as in the United States, it was natural that there should be displayed much diversity in the designing of valve gear; and there was, but it did not manifest itself on this side of the Atlantic as it did in Europe. European engineers and inventors devoted themselves to devising ingenious arrange-

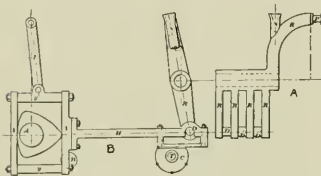

FIG. 18. ROSS WINANS' VALVE GEAR.

ments for driving the valves; American engineers exhausted their efforts in working out the means of cutting off steam so that the benefits of expansion should be enjoyed. American locomotive engineers have not always courted simplicity, but that, as a rule, has been their tendency, and they seldom went far astray on the designing of valve motion. The drop hook seemed to appeal to their ideas of simplicity, and it was the popular valve motion for years, with the addition of an independent cut-off valve.

**VAGUE IDEAS ON STEAM EXPANSION.**

It seems strange for a twentieth century engineer to reflect upon, but it is a fact that the pioneer engineers had very

periments were made on the Liverpool & Manchester Railway about 1844 with valves having about half-inch lap, and decided economy in the use of fuel resulted. The chief engineer of the railway, and most other engineers of that day, attributed the saving to the earlier release of steam that resulted from putting lap on the valve.

American engineers appear to have had a better conception than their European brethren concerning the effect of valve lap, for James, Davis and Long applied lap with a view to expansion of steam as early as 1832. The only objection found to lap on this side of the Atlantic was that it caused difficulty in starting a heavy train. As handling the train easily was considered more important in the pioneer railway days than saving fuel, few American locomotives had their valves equipped with much expansion producing lap until the link motion came into use. When the men in charge of our railroad machinery began to realize the advantage of expansive working, they applied independent cut-off valves, which did not interfere with the starting power of the engines, in preference to lap. The introduction of the link motion did not immediately displace the independent cut-off, but it gradually fell out of favor as the attributes of the link motion became understood and its merits became appreciated.

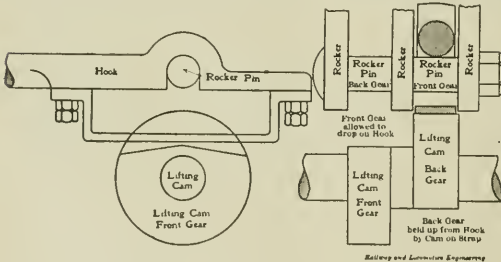

FIG. 19. COMMON FORM OF DROP HOOK MOTION.

vague ideas about the advantage of steam expansion and how expansion could be most readily secured. Few of the early locomotives had more lap on the slide valves than was sufficient to prevent both ports from being partly open at the same time. A series of ex-

\*This is part of a historical article for my forthcoming book, "Development of the Locomotive Engine." If readers find mistakes of facts, they will oblige me very much by pointing them out.  
ANGUS SINCLAIR.

periments were made on the Liverpool & Manchester Railway about 1844 with valves having about half-inch lap, and decided economy in the use of fuel resulted. The chief engineer of the railway, and most other engineers of that day, attributed the saving to the earlier release of steam that resulted from putting lap on the valve.

American engineers appear to have had a better conception than their European brethren concerning the effect of valve lap, for James, Davis and Long applied lap with a view to expansion of steam as early as 1832. The only objection found to lap on this side of the Atlantic was that it caused difficulty in starting a heavy train. As handling the train easily was considered more important in the pioneer railway days than saving fuel, few American locomotives had their valves equipped with much expansion producing lap until the link motion came into use. When the men in charge of our railroad machinery began to realize the advantage of expansive working, they applied independent cut-off valves, which did not interfere with the starting power of the engines, in preference to lap. The introduction of the link motion did not immediately displace the independent cut-off, but it gradually fell out of favor as the attributes of the link motion became understood and its merits became appreciated.

to give motion to the valves. On valve motion, as on most other engineering questions, Ross Winans was a law unto himself. He understood more about steam and its ways than other engineers, and his practices in designing were influenced by his knowledge.

Figs. 18, 19 and 20 illustrate the valve motion that Winans applied to his camel back engines (RAILWAY AND LOCOMOTIVE ENGINEERING, 1890, page 185).

The cut-off mechanism was peculiar in that it worked steam expansively, while all the time operating the valve its full stroke, and it is claimed by many engineers that it was the nearest approach to an ideal cut-off ever made on locomotives, using as it did but one valve, and being particularly simple. The valve motion of the day was the drop hook, and this Winans adopted, and added the cut-off. Across between the

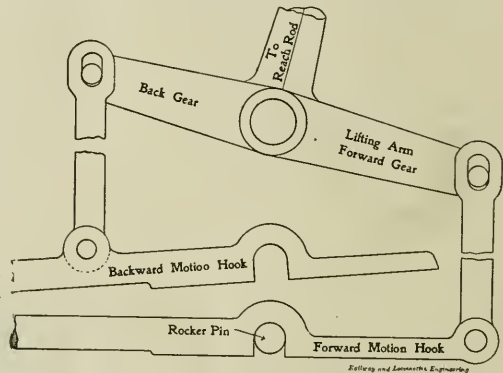

FIG. 20. METHOD OF REVERSING DROP HOOK MOTION.

frames of his "camel," just in the center of the wheel base, was a shaft on which were the two rockers—one for each side. These rockers, shown in A, had a curved arm that extended over the wheels and terminated in a bearing for the back end of the valve stem, as shown at P; on top of this curved arm was cast a socket, shown at S, for inserting the starting bar when necessary. The shaft went through the body of the rocker, as shown by the dotted lines; below the shaft there were four arms carrying at the bottom a steel pin or bolt that extended through them all, forming three bearings, as shown at D, D', D'', B. Now, there were two eccentrics on a side—one set for the forward and one for the backward motion; these eccentrics operated drop hooks, each having its own place in the lower end of rocker. Then, besides the eccentrics, there was a cam, as shown in B, operating another hook. This cam worked in a square frame or yoke (Y), as shown, the frame being suspended from the boiler by the hanger L, and it operated a hook (H) exactly like the drop hooks of the eccentrics.

The reverse lever merely tumbled the shaft T, and this shaft carried six cams like C, three for a side, each cam being under a hook. When the lever was in the center, or "out" notch, all the cams were turned enough to lift the hooks clear of the pins in the lower arms of the rocker, and the valves would not operate while the hooks worked back and forth, sliding on the cams. If the lever was put into the



back-up notch, the cams under the back-up hooks presented their low sides at the top, and the back-up hooks would fall down and engage the pin *D*, and operate the back-up gear.

If the lever was put in the forward

center, the valve was opening very fast, and opened wide almost instantly, and closed with a quick motion when the pin reached the quarter; here the valve rested, allowing the steam to work expansively, while at the same time holding the exhaust

open for the other side, until the piston had traveled nine-tenths of the stroke.

THE FAVORITE DROP HOOK.

The most common form of drop hook motion used in the United States is shown in Fig. 20 (L. E., 1901, p. 157), which gives the motion for forward or backing

eccentric. Throwing the reverse lever forward held the backing hook out of reach of the rocker pin and allowed the forward hook to drop upon the pin when it came into position. The starting bars were connected with the valve rods and enabled the engineer to move the valve till the hook would drop into place.

This form of motion was used by the Amoskeag, Taunton, Rogers and others, and many engineers of those days declared it could not be beaten.

THE FAVORITE V-HOOK.

The V-hook motion, which came decidedly into favor after being introduced into the United States about 1842, proved a good compromise between the drop hook and the link. It became popular principally through the engineers finding it easier to operate than the drop hook and because it involved the use of fewer parts. Fig. 21 (L. E., 1901, p. 272) is a fair representation of the V-hook motion used on nearly every railroad in the United States in 1850. When the motion was put in forward gear the hook of the forward eccentric engaged the rocker pin, at the same time dropping the backing hook so that it swung clear. When the back-up hook was engaged in the rocker pin the forward motion in its turn was raised and swung clear of the other parts.

An odd form of connected double hook, shown in Fig. 22 (L. E., 1901, p. 158), was used by Rogers, Swinburne and others. Its action was the same as using the link all the time in full gear.

BALDWIN VALVE MOTION.

As already mentioned, Baldwin at first used a modification of the Carmichael valve gear, with a single flat hook for each cylinder. He made use of a single fixed eccentric for each cylinder. Each eccentric strap had two arms attached to it, one above and the other below, and as the driving axle was back of the fire box, these arms were prolonged backward under the foot board, with a hook on the inner side of the end of each. The rock shaft had arms above and below its axis, and the hooks of the two rods of each eccentric were moved by hand levers so as to engage with either arm, thus producing forward or backward motion. This motion was adhered to for four or five years.

The first change made by Mr. Baldwin in his valve motion was to adopt the double eccentrics with a single flat hook. In 1840 he built some locomotives for Austria with a sort of link motion, being before that motion was reinvented by Williams, of the Stephenson works. It did not indicate, however, that he had come to favor a link motion. In 1845 he introduced what was known as the half stroke cut-off. In this device the steam chest was separated by a horizontal plate with an upper and lower compartment. In the upper compartment a valve, worked by

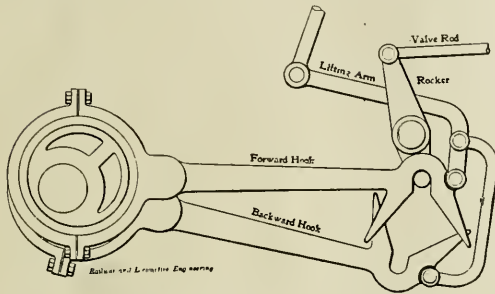

FIG. 21. COMMON FORM OF V-HOOK MOTION.

notch, the back-up hooks were lifted, and the forward motion hooks dropped into gear.

Ahead of the forward motion notch there was another, for the cut-off, and when the reverse lever was dropped into that, both forward and back motion hooks were lifted out of gear, and the hook of the cut-off cam dropped in.

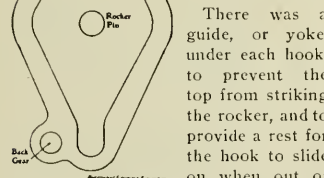

FIG. 22. ROGERS'S CONNECTED DOUBLE HOOK.

There was a guide, or yoke, under each hook, to prevent the top from striking the rocker, and to provide a rest for the hook to slide on when out of gear. These hooks had nothing to hold them in gear but their own weight, and the friction in forward motion, and once in a while in backing up, if the eccentrics got dry, they would unhook. If the engine was standing still and out of gear, or it was desired to change from forward to back, or vice versa, the hook that was out could not be engaged with the pin *D*, so a starting bar was dropped into the socket *S* on the rocker, and the rocker moved until the hook engaged the pin; then the bar was taken out and set into a stationary socket provided for it.

The "four motion cam," as it was called, was so shaped that it filled the frame *Y* in every position, so that there was no knock. It caused the valve to travel five inches, just as the eccentrics did, but the valve stood still twice during each revolution. When the pin, which is shown at *B*, was at the dead

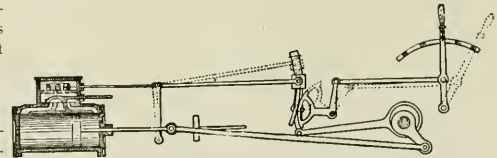

FIG. 23. BALDWIN'S VARIABLE CUT-OFF MOTION.

a separate eccentric and having a single opening, admitted steam through a port in this plate to the lower steam chamber. The valve rod of the upper valve terminated in a hook which engaged with the upper arm of the rocker shaft. When thus working it acted as a cut-off

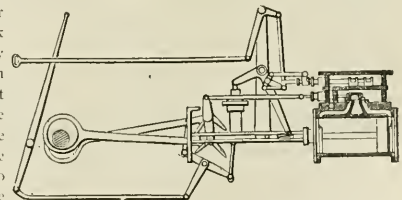

FIG. 24. FIRST DROP HOOK MOTION.

at a fixed part of the stroke, determined by the setting of the eccentric.

APPROPRIATE VALUE OF USING STEAM EXPANSIVELY.

By this time American locomotive builders had come to realize the importance of using steam expansively, and

most of them were putting variable expansion gears upon their engines. After using the half stroke cut-off for about eight years, Mr. Baldwin in 1853 introduced the variable cut-off arrangement illustrated in Fig. 23.

Concerning this motion Mr. Baldwin

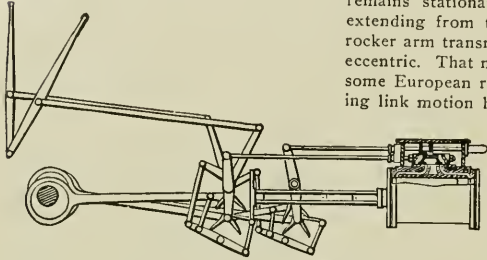

FIG. 25. ROGERS VALVE MOTION. ==

wrote: "I shall put on an improvement in the shape of a variable cut-off which can be operated by the engineer while the machine is running, and which will cut off anywhere from 6 to 12 ins., according to the load and the amount of steam wanted, and this without the link motion, which I could never be entirely satisfied with."

That was written ten years after the link motion had been introduced, and indicated that that motion was slow in finding favor among American engineers.

#### ROGERS INTRODUCES THE LINK MOTION.

On the first two locomotives built by Rogers, Ketchum & Grosvenor drop hooks were employed, operated by eccentrics placed outside of the driving wheels. Early realizing the necessity of a valve motion that would provide for using the steam expansively, in 1843 he designed and brought into use the motion shown in Fig. 24. That was a rather complex motion, with a riding

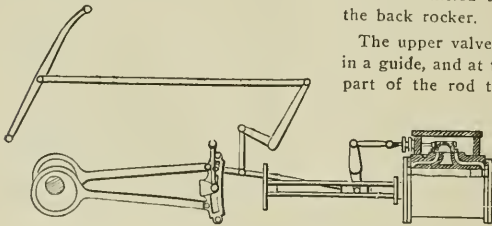

FIG. 26. ROGERS SUSPENDED LINK MOTION.

cut-off valve. A few years later Mr. Rogers began to apply the motion shown in Fig. 25, which was a slight improvement on the other. There existed among American railroad master mechanics and locomotive builders a strong prejudice against the link motion, and complex mechanisms continued to be invented to perform the functions that the link did very satisfactorily with a minimum of parts.

Thomas Rogers was the first American locomotive builder to rise above the prejudice against the link motion. In 1849 he introduced the suspended link motion shown in Fig. 26 upon some locomotives built for the Hudson River Railroad. In this motion the link remains stationary and a radius rod extending from the link block to the rocker arm transmits the motion of the eccentric. That motion was popular on some European railways, but the shifting link motion has been the real link motion of American locomotives.

Rogers soon changed to the under-hung shifting link shown in Fig. 27. For years that form of suspension rivaled the upper-hung link in the favor of our master mechanics.

#### "JOHN STEVENS" VALVE MOTION.

The persistence of the sentiment in favor of independent cut-off valves is very well illustrated in the valve motion of Stevens engines built for the Camden & Amboy Railroad in 1849. Referring to the mechanism illustrated in Fig. 28, the two main eccentrics were located inside the wheel and operated the large double hooks shown, with the curved lifting rod. These worked the main rocker arm and the main valve, and the reversing was done by changing from one hook to the other by handling one of the levers in the cab. The independent cut-off was a small valve riding on top of the main valve and operated by a return crank eccentric on the main crank pin. This motion was transmitted to the valve through the back rocker.

The upper valve stem was supported in a guide, and at the end of the square part of the rod there was a joint to

pin that could be engaged by the lower V of the double hook.

In starting the cut-off lever was moved to engage the lower hook. This made the cut-off valve come to the center of the main valve, and as that always ran full stroke, it would cut off steam, the cut-off motion merely sliding, the block on the upper rod doing no work. As soon as the engine was under way the engineer threw on the cut-off which disengaged the lower hook from the main valve stem and engaged the upper one with the cut-off valve, which traveled on top of the main valve, cutting the steam off short, much as the link does when notched up, except that, as the main valve controlled the exhaust, the latter was carried well to the end of the stroke.

That motion was designed by Edwin A. Stevens, who founded the Stevens Institute of Technology, Hoboken, N. J., and seven of the engines were built by Norris, of Philadelphia, in 1849.

#### OPPOSITION TO LINK MOTION OVERCOME.

Although the introduction of the link motion was vigorously opposed by many master mechanics, it forced itself steadily into use, and in a few years became the recognized valve motion for locomotives over the whole of the American continent. The simplicity of the device soon made it popular with the men who handled the locomotives,

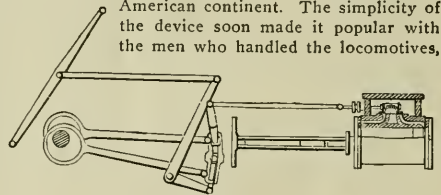

FIG. 27. ROGERS UNDER-HUNG LINK MOTION.

and the rarity of breakage, with the low cost of repairs, brought it into favor with the officials responsible for locomotive operating. Mr. Baldwin had opposed the use of the link motion for theoretical reasons; but in 1854 he built some engines for the Central Railroad of Georgia, one having the link motion specified, while the others had the Baldwin variable cut-off. This was

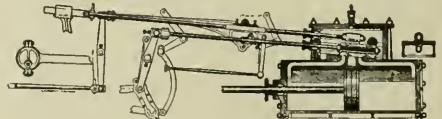

FIG. 28. "JOHN STEVENS" VALVE MOTION.

which was pivoted the rod whose other end terminated in the double V-hooks. This loose end was supported and held by the bell crank shown back of the cylinder. On the upper valve stem there was a loose block running as a crosshead on a square section of the rod. This was driven by the cut-off eccentric. Just below it on the main valve stem was another block held rigid by screws. This block also carried a

understood to be a test case. The officials of the road, after a few months' experience with the two forms of valve motion, decided positively in favor of the link, and Mr. Baldwin concluded that he had been mistaken in his opposition to the link motion, and became one of its fast friends. Nearly all other locomotive builders in America by this time had been converted to patronize the link motion.

The Westinghouse Electric & Manufacturing Company has placed upon the market a line of core type transformers as an addition to the several forms with which users of alternating current apparatus are already familiar. They will be known as type C and are simply an addition to the many standard forms, so that Westinghouse transformers of any desired form and construction may be obtained to meet the varying demands of present day light and power service.

#### New Air Strainer.

A new design of air pump strainer, designed by Mr. Wm. J. Ogan, of Dayton, Ohio, is illustrated here.

It consists essentially of a body portion which screws into the wall of the air cylinder in the usual manner; an inside and an outside screen, having a

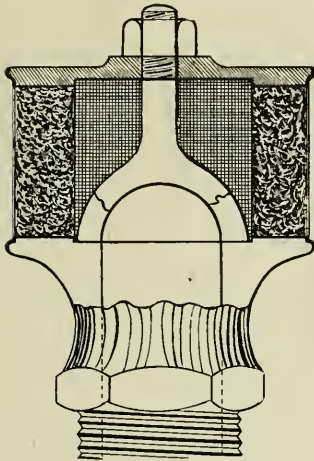

NEW AIR STRAINER.

layer of curled hair or felt between them; and a cap which holds the screens and curled hair in place, and which itself is held in position on the stem through the center of the screens by a small nut, as shown.

This design looks as though it would effectually prevent the entrance of dirt to the air cylinder.

The Quincy, Manchester, Sargent Company has been incorporated and will take over the business of the Railway Appliances Company. This includes the business and plant of that concern at Chicago Heights, Ill., formerly owned by the Q. and C. Company, also the business and plant of the Pedrick & Ayer Company, of Plainfield, N. J. This company will also act as sole selling agent for the product of the Elastic Nut & Bolt Company, of Milwaukee, Wis. The address of the new company is Old Colony building, Chicago, and their New York office it at 114 Liberty St.

#### Object Lessons on Couplers.

"On many things we are practically standing still, or making little, if any, progress." Thus spoke Mr. W. E. Symonds at a recent meeting of the Western Railway Club, when presenting his paper on "Object Lessons in the Mechanical Department." As an example of where slight progress was to be observed, he instanced the M. C. B. coupler, and though giving the M. C. B. Association credit for establishing the contour lines of the standard coupler, he pointed out that the couplers were not interchangeable, as far as their various parts were concerned. There are about seventy different couplers which fulfil the requirements laid down by the association, and which must be accepted, while the fact that their interchangeability is limited makes all railway companies keep constantly on hand a large stock of spare couplers and parts thereof for those styles which are in common use. This means the expenditure of thousands of dollars, and idle money while the spare couplers are not in use. This unproductive outlay could be avoided if a standard was finally adopted, and if the term was made to mean what it does when applied to an axle or a car wheel or a journal bearing.

Reference, he said, might also be made to many other devices and kinds of material entering into the construction of cars and locomotives, especially of cars, as these played an important part in the operating expenses of a road. Every company believe that they have the best coupler, draw gear, trucks, bolsters, brake beams, shoes, car doors and roofs. In many cases the design approved by one road was practically contradicted on another. Freight cars are all the time being smashed, while motive power officers have all sorts of excuses except the right one, and are content to throw the blame for having a large number of bad order cars upon the supply people for not providing them, let us say, with a draw gear that will not break.

There is, however, a movement on foot in the M. C. B. Association to adopt a uniform standard coupler that will be worthy of the name. We have in this country now about two million freight cars, which means that there are in use approximately about four million couplers. About three years ago, Mr. Symonds said, he had looked up the Patent Office records concerning couplers, and had found that at that time there were more than seventy so-called M. C. B. couplers which conformed to the contour lines laid down by the Association, and that there had been about five thousand patents granted on car couplers. Out of the odd seventy M. C. B. couplers not more

than twenty or twenty-five are in general use.

Under the prevailing method of car interchange these two million cars belong to different roads, as shown by the names they bear, but, in so far as the business of the railways is concerned, these two million cars belong to American railways, and the necessity for making them so that they can go anywhere at any time, without delay, is apparent. As it is these cars are subject to annoying delays at various places, and delay impairs the earning power of the car, and there is an additional loss on account of the money invested in the idle car, and, furthermore, it occupies track room where it stands and waits.

As an instance of such a case, Mr. Symonds continued: "I recall an instance a few years ago of a car belonging to a road of which I was a mechanical officer, being detained out in Texas for some small castings that were standard to a car. We had on the line I was connected with so many cars and so many standards, that on receipt of the order we sent what we supposed was wanted, and it proved to be the wrong casting. We duplicated the order with another standard, and that was not right, and it was duplicated again, which all goes to show that the system on that particular road was very poor in taking care of standards, and that too many standards were maintained. After the car was delayed some three or four months, owing to changes that sometimes occur in railway service, I took service with the company that had this car in its possession, and it happened to be standing right near my office. I recalled very distinctly the serious delay that I had been grumbling about, and inquired why they did not fix the car and send it home. I now found myself confronted with the conditions I had complained of. Well, it resulted in about three months' longer delay in getting the right casting, which, I think, was a center plate for the car. That delay and trouble never would have been necessary at all, and could not have occurred had anything like a common standard existed."

It has been decided to proceed at an early date with the construction of 1,233 miles of railway in the Philippine Islands. About 833 miles are to be built on the island of Luzon, and the remaining 400 miles on the islands of Panay, Negros, Cebu, Leyte and Samar.

Publishers of railway papers have reason to be thankful that the agitation against granting courtesy and advertising transportation has not struck the railways in Canada.

# Railway and Locomotive Engineering

A Practical Journal of Railway Motive Power and Rolling Stock.

Published Monthly by

ANGUS SINCLAIR CO.,

136 Liberty Street, New York.

Telephone, 984 Cortlandt.

Cable address, "Loceng," N. Y.  
"Glasgow," "Locauto."

## Business Department:

ANGUS SINCLAIR, President.  
FRED M. NELLIS, Vice-President.  
JAMES R. PATERSON, Sec'y and Treas.

## Editorial Department:

ANGUS SINCLAIR, Editor.  
GEO. S. HODGINS,  
JAMES KENNEDY, } Associate Editors.  
J. P. KELLY,

## Advertising Department:

Eastern Representative, S. I. CARPENTER, 170 Summer St., Boston, Mass.

## British Representative:

THE LOCOMOTIVE PUBLISHING CO., Ltd., Amen Corner, Paternoster Row, London, E. C.

## Glasgow Representative:

A. F. SINCLAIR, 15 Manor Road, Bellahouston, Glasgow.

## SUBSCRIPTION PRICE.

\$2.00 per year, \$1.00 for six months, postage paid in the United States, Canada and Mexico. For other parts of the world, \$2.50 or ten shillings. Single copies, 20 cents. Remit by Express Money Order, Draft, Post Office Order or Registered Letter. Mailing address can be changed as often as necessary—always give old and new address, and if you subscribe in a club, state who got it up. Please give prompt notice when your paper fails to reach you properly.

Entered at Post Office, New York, as Second-class mail matter.  
Copyright by Angus Sinclair Co., 1906.

For Sale by Newsdealers Everywhere.

## To Right a Heinous Wrong.

Railroad men of all classes, but more especially those employed in train service, ought to combine to give vigorous and enthusiastic support to a measure which has been favorably reported by the House Committee on the Judiciary of the House of Representatives. It is a bill which, if passed, will end the iniquity of what is known as the "Fellow Servants" principle of the common law. It applies to railroads as common carriers and makes them liable for damages in case of death or injury to employees which may be the result of negligence of officers, agents or employees, or defect or inefficiency of cars, engines, appliances, machinery, track, roadbed, ways or works. Except in some States, which have enacted similar legislation, an employee cannot now recover for injuries which are caused by the negligence of fellow servants. The proposed change in the laws would place railroad employees on the same footing before the law that other people now enjoy, a very reasonable demand in our opinion.

We know of no single law which has been employed to inflict so much injustice as the so-called "fellow servant" law, which is an inheritance of the English common law imported into this coun-

try with the early settlers from England before the Revolution. In the times when this law originated, fellow servants were all acquainted with each other, and if there was a reckless, careless or incompetent man among them whose dangerous characteristics were likely to put the persons of his fellow servants in jeopardy, they were expected to protest against that person being kept in the same employment. Under the industrial conditions that have developed with the growth of mechanical industries, more especially in connection with transportation, there are many fellow servants never seen by each other, and of whose characteristics there is no means of judging. Nevertheless, when an employee of a firm or company performs an act of carelessness or recklessness which results in the death or injury of another employee, the company is exonerated from responsibility and the blame is laid upon the sufferer who is accused of contributory negligence because he did not protest against the employment of the careless or reckless man whom very likely he never met.

There is not the faintest ray of justice in the law, and it is decidedly in conflict with the spirit of popular liberty. A careless telegraph operator hired by a railroad company because his services were cheap fails to deliver a holding order and a collision results causing the death of several passengers and trainmen. The heirs of the passengers collect damages, but if those of the trainmen, left behind in penury, go into the courts with claims for damages for the loss of a husband or a son they are promptly met with the reply that the company is not responsible for the act of a "fellow servant."

Now is the time to end this article of iniquity. All railroad organizations ought to present strong petitions to the House of Representatives at Washington to pass the bill repealing the fellow servants law. In addition to combined efforts, railroad men ought to take up the matter with the members of Congress of their districts and urge that this measure of tardy justice be extended to the dependents of long suffering railroad employees.

A curious circumstance in connection with this law, which has inflicted so much injustice upon Americans, is that it has been practically repealed in the land of its birth. Under the sensibly directed labor interests of the British Isles, laws have been passed making railway companies responsible for accidents to their employees. If our labor organizations would combine for a similar purpose, they would promptly receive their rights.

Vigorous action is necessary, for the full force of corporation influence will be exerted against this measure of tardy justice.

## Preserving Head Light Glasses.

There have been more than one plan adopted to keep circular head lamp glasses from breaking, especially since the introduction of the electric light. One of them is to make the transparent front out of parallel strips of glass standing vertically, as is done with marine search lights. This arrangement has the effect of giving a chance for the whole partition to expand unequally, and if breakage occurs only one or two strips would probably be affected. In such a case the injury would be local, as the doctors would say.

We have been favored with a sketch reproduced elsewhere in this issue of another way of helping to preserve the glass, as applied to some locomotive headlights on the Frisco System, at Monet, Mo. The plan adopted is to cut a long, narrow strip in the underside of the circle which holds the glass and this introduces a stream of cool air up along the inside which has the effect of protecting the glass and keeping it from becoming as hot as it otherwise would.

Years ago Tyndall found that the energy needed for the production of an electric light was expended in two ways. One was in the actual production of light and the other was consumed in a non-luminous form, such as heat, and in overcoming internal resistances. Out of the total amount of energy supplied the non-luminous form absorbed eight times that of the light itself. In other words, if 9 be the amount of energy expended, 1 part becomes sensible to us as light and 8 parts are practically turned into heat.

In an address recently delivered by Sir James Dewar before the Royal Institution in London, he spoke of the great difference between the luminous and non-luminous energy of artificial light. He told his hearers that a candle gave out 2 per cent. of the energy it develops, as light, and 98 per cent. as heat. The incandescent electric lamp does a little better than a candle; it turns 3 per cent. of the energy flowing along its wires into light, but 97 per cent. is turned into non-luminous radiation or dark heat, as it is sometimes termed.

The idea of the opening below the glass is intended to, as it were, interpose a moving curtain of cool air between the glass and the source of light and heat and so keep both sides of the glass at as nearly a uniform temperature as can be. The arrangement facilitates the free movement of air inside the case, and though it cannot prevent the action of direct radiation, it helps to keep down the temperature of the air inside the lamp case.

### Machine Shop Reamers.

It is a remarkable fact that while machine shop tools have reached a degree of perfection which can hardly be surpassed, bolts and studs, especially in locomotive construction and repair, are not as well fitted as they should be. The evil lies in a lack of uniformity of shop practice. With the general admission that taper bolts are a necessity in locomotive work, reamers are generally made to a standard of one-sixteenth in taper to one foot in length. Gauges are also made to fit the reamers, and it might naturally be supposed that it would not be a difficult operation to prepare a stock of standard bolts or studs ready to suit holes prepared by standard reamers.

The trouble is not far to seek. A reamer having been used for some time must be slightly worn. Each time it is used it becomes a little more dull. The point of the reamer generally does more work than the portion nearer the head, and, consequently, wears faster. As holes must necessarily be drilled straight and as the different parts to be held together do not always perfectly meet each other, not only is the point of the reamer forced to do more cutting than the main body of the reamer, but all the metal must be removed necessary to convert a straight hole into a tapered hole. A careful sharpening of the reamer by a skilled toolmaker might continue the exactness of taper for some time, but this if attempted is very seldom accomplished. The result is that the bolts in stock do not fit. A hasty rub of a file or some other temporary makeshift is adopted and the ill-fitting bolt or stud is driven into its place with a degree of over compression in some part, and no pressure on another part. This is especially the case with cylinders and saddles where the reamers are much used and frequently sharpened, the growing irregularity causing delay and encouraging a tendency to slipshod work which has its logical sequence in structural weakness, giving early indications of rapidly breaking up.

Among the best plans we have seen is that in vogue in the Baldwin Locomotive Works, where they have perfected a system of gauges consisting of taper standard plugs fitted into ring gauges. A convenient milled handle is fitted to the end of the plug. These plugs and rings are retained in the store room as standard to try other gauges by. The gauges used by the men at the turning lathes are made of cast iron similar to the gauge described in connection with the steel plug, but are rectangular, so as to rest readily on the lathe bed. These lathe gauges are reamed to such a size that the standard plug in the store room will be flush with the top of the gauge precisely as is the case with the stand-

ard ring in the store room on the same plug. Bolts turned taper must fit this gauge with the head just touching the top of the gauge, and without rattle or shake over the length of the gauge. The reamers used for tapering the holes are long enough to have several inches left over to allow for redressing. Thus a reamer one inch in diameter at its smallest end, at one foot from small end should be 11/16 ins. in diameter, and if three inches longer, it should be 1 5/64 ins. in diameter at the largest end. Such a reamer may be reground until its largest diameter has been reduced to the standard size. These reamers are guarded at their upper end by a collar driven on and covering the entire unused part of the reamer, which collar can from time to time be dressed off at the lower end to suit the gauge and keep the size correct.

### Collision on the D. & R. G.

About the middle of last month there was a most disastrous head-end collision on the D. & R. G., near Adobe, Col., in which about 22 people lost their lives and four of the train crew were killed. Both of the wrecked expresses were filled with passengers.

The westbound train had two engines, and for some reason it suffered most when the crash came. The cause of the collision is said to have been a "lap" order. The press dispatch says: "Orders had been issued for the trains to pass at Adobe, about half a mile from the scene of the collision, but No. 16, when it pulled out of Florence, was given orders to pass No. 3 at Beaver, five miles east of Portland. It is said that the second order was to have been given to No. 3 at Swallows, but that the train went through without receiving any orders there."

Whoever may have been actually responsible for non-delivery of the order, he has been the means of bringing a cruel death to many innocent persons, and he has again directed attention to the melancholy fact that the death roll on American railroads is still alarmingly great.

The Interstate Commerce Commission, in Bulletin No. 17, covering the months of July, August and September, 1905, says that during that time, "the total number of collisions and derailments was 3,135 (1,605 collisions and 1,530 derailments), of which 240 collisions and 141 derailments affected passenger trains. The damage to cars and engines and roadway by the accidents amounted to \$2,540,908."

The engineer of the head engine on No. 3, it is reported, leaves a wife and three children, and under the existing "fellow servant law" these unhappy survivors probably have no legal claim for compensation. In this connection we re-

fer our readers to the editorial on page 158 of this issue.

The making of a meeting point for two opposing trains is a serious matter, and after it has been made it is again a serious matter to change it. It is possible to do this quite safely and it is one of the regular incidents in train operation all over the country. The fact that it can be, and generally is, safely done, does not, however, remove the possibility of disastrous failure which the inherent weakness of the system undoubtedly carries with it. When the meeting point of these two trains was changed, one of them received the notification and the other did not.

There is always the chance that someone will forget or that the order signal will not be observed or will even be disregarded. There seems to be good cause for the feeling of uncertainty in the mind of the public concerning existing methods when such accidents as this one can happen on otherwise well managed roads.

There is one thing the need of which is growing more apparent as each fatal misunderstanding is paid for in human beings' lives. It is that some means of stopping a moving train from the outside is absolutely necessary. The automatic stop signal, if applied at stations, would compel a halt, either by mechanical action or by reason of the knowledge that it was there. Such a stop would force inquiry to be made; that is the point. In this instance the whole system worked out so that the lives of all concerned were left entirely in the hands of one overworked and sleepy operator. The terrible result of his failure to deliver the latest order shows how desperately dangerous it is to depend completely on the unaided memory of one man, where the supremely important work of moving passenger trains is involved.

A stop signal could not be passed, and its lowering to the proceed position could be made dependent on the concerted action of two or more persons, just as the manual controlled block system now is, and the reason for the positive blocking of a train at a station would become apparent in the receiving of necessary instructions or in the safe delivery of a definite order.

### Honest for Honesty's Sake.

It is so seldom that one runs across a man who is honest just because he wants to be honest, says the New York Globe, even when it would pay him to be dishonest, that such an instance is really worth recording. The Pennsylvania Railroad is fortunate enough to have at least one such man in its employ. His name is W. H. Conrad, and he is a wheelsman on the ferryboat St. Louis.

Last Saturday night a man who lives in Newark was on his way home, with his wife, from the Sportsmen's Show. His wife carried in her handbag, besides a large amount of cash, some valuable securities. As they left the ferry-boat on the Jersey side she picked up a package of souvenirs she had bought at the Garden, and left her purse lying on the seat. The loss was not noticed until the train was well under way.

At the first stop they got out and took a trolley back to Jersey City. At the railroad terminal they inquired the way to the lost property clerk's office, in the hope, if futile as it seemed to them, that the lost handbag might have been turned in.

Just as they were going into the lost property room Wheelsman Conrad came in from another direction with the handbag, its contents intact, in his pocket. His boat had made a round trip since the owners of the bag had left it, and he had found the bag on the way to the New York side. It was almost necessary to use force to get him to accept the \$5 bill that the owner of the bag insisted on giving him.

#### Railroad Machinists.

A gratifying result of the era of general prosperity is the demand for skilled mechanics employed in the construction and repair of railroad appliances. The shops are literally crowded with new work, besides rebuilding, general repairing and a constant increase in roundhouse work, owing in many cases to the shortage in the number of locomotives and the necessity of keeping every wheel moving. In the latter class of work it is observed that there is a general tendency to provide better facilities and better conditions, with the result that a better class of men are engaging in roundhouse work. Higher wages are being obtained, and, in our opinion, it is high time, in view of the fact that men who are engaged in the building trades, most of the work being of the simplest kind, have been paid more than double that of the railroad machinist, whose work is nearly always of the most exacting and difficult nature, and skill in which can only be acquired by the closest attention through many years, by which a wide and varied experience is gained. It is doubtful, indeed, if there be any species of mechanical work that requires more skill with rapidity of dispatch, and often under the most trying conditions, than that of railroad machinists, and an increase in their wages and a shortening of their hours of labor ought to come with more steam to it than it has done. The present appearances are very promising and the future is full of hope.

#### Costly Blunder.

American railroad men who cause accidents by carelessness or errors of judgment seldom receive punishment when prosecuted for their misdeeds. One of the most disastrous kind of railroad accidents is trains running into sidings by the switch having been left open by some careless trainman. Thousands of people have lost their lives through this cause, but we never heard of any one being sent to jail for the criminal carelessness of leaving a switch open.

This thought comes to us in reading how grimly the law in most foreign countries deals with railway servants responsible for causing accidents. Word has just been received of the trial of a railroad signalman in Prussia who caused a collision through signaling "line clear" when there was a train on the block. Although the man had a clean record of long, faithful service, the blunder cost him four months in prison.

#### Long Spittoon.

The existing style of American railroad car, with seats on each side of a longitudinal aisle, originated on the Baltimore & Ohio Railroad about 1832. The arrangement met with warm opposition, and the arguments against it reflected somewhat against the personal habits of the American citizen in those days when the word "graft" had not been invented. The opposition insisted that the passengers would be able to expectorate along the whole length of the aisle, and that in consequence it would become an elongated spittoon. Yet some people think the world is growing better and its inhabitants cleaner.

#### First Railroad Signal.

What may be regarded as the first signaling system used on an American railroad was tried by the Allegheny Portage Railroad in 1832. A large post called a "center post" was set up half way between two turn outs, and the rule was established that when two drivers met with their cars on the single track, the one that reached the post first had the right of way. As the line was very crooked, a rule of this sort was necessary, but similar rules were about the same time established on the Philadelphia & Columbia and other lines to put the car drivers under some sort of control.

#### Accident Record.

Accident Bulletin No. 17, issued by the Interstate Commerce Commission, for July, August and September, 1905, shows that there were 1,053 killed and 16,386 injured among passengers and employees on railroads. This is an increase

over those reported in the three preceding months. The bulletin says: "The figures are doubtless in a large measure a reflection of the heavy traffic done by the principal railroads of the country during the busiest months last summer."

According to a Blue Book just issued by the British government, 337 people were killed and 1,795 injured on railways in the United Kingdom during the three months ended September 30, 1905. Among the killed were 61 passengers.

#### Book Notices.

Link Motions, Valves and Valve Setting. By Fred. H. Colvin. Published by the Derry-Collard Company, New York. 1906. Price, 50 cents.

This book has 82 pages and is illustrated by 45 line engravings. It endeavors to make clear some of the perplexing points concerning valves and valve motions, and valve setting is in a chapter by itself. The contents include locomotive link motion, valve movements, setting slide valve, analyses of diagrams, modern practice, slip of block, slide valves, piston valves, setting piston valves, and a brief description of the Joy-Allen gear, the Walschaert, the Gooch and the Allfree-Hubbell gears. An inserted diagram opposite page 36 shows how valves, piston and slide, must be connected for all conditions met with in ordinary locomotive practice. The book is 4x6 ins., bound with flexible cover and can be easily carried in the pocket.

Modern Locomotive Engineering Handy-Book. By C. F. Swingle, M.E. Published by Frederick J. Drake & Co., Chicago. 1905. Price, \$3.00.

The aim of the author in compiling this work was to furnish to locomotive engineers, firemen and others, in a clear and concise form, such information as will be useful to them in their work. The subject-matter is arranged in such a manner that it forms a practical treatise on the construction, care and management of a locomotive. Boiler work is dealt with and valves and valve gear is taken up in due course. Chapter V is devoted to valve setting and goes into it in a practical way. The types of compound engines are set forth, and general locomotive breakdowns, and what to do in emergencies, is one of the features of the work. The book contains numerous tables and engineering data, and is about 4½x6½ ins. It has, with index, 630 pages, and is well illustrated. The book is bound in a flexible leather cover.

The Argentine Congress has authorized the construction of 2,500 miles of railway, and it is said that French and Belgian capitalists have offered to supply the necessary funds.

**Black River Bridge, N. Y., C. & St. L.**

The bridge over the Black river at Lorain, Ohio, on the New York, Chicago & St. Louis Railroad, commonly called the Nickel Plate, is for a single track, and consists of a swing span and one 60 ft. plate girder span. Our illus-

and followed by a train of 4,000 lbs. per foot. The swing span is operated by two 30 h.p. electric motors. The principal members of the bridge are composed of medium steel having an ultimate tensile strength of from 60,000 to 70,000 lbs. per sq. in.

**Map of the Isthmus.**

The Panama ditch digging operations are always of interest to the people of this country. The waterway is, however, called the Isthmian Canal by those who prefer a more dignified style, but both expressions refer to the same thing. With a view of helping all classes in their efforts to obtain information concerning this great national work, the Fitz-Hugh Luther Company, of New York, have issued a map about 3 ft. 8 ins. long by 1 ft. 10 ins. high, which shows the whole thing splendidly.

The map is divided into three horizontal sections, the top one giving a perspective view of the canal, and shows that the Culebra cut is through what Nature left of the Rocky Mountains when she was flattening things down there for De Lesseps. The center division is a vertical section of the isthmus along the canal route. The work done by the first and second French companies, and that yet to be done, are shown by three different colors. It appears that the work accomplished is about equal to the icing on a layer cake, and Uncle Sam will have to take the cake in this instance, as he has done in others. The lowest section on the map is a bird's-eye view of the canal as it will appear in A. D. 19—, with President Roosevelt's locks com-



BLACK RIVER SWING BRIDGE ON THE NICKEL PLATE LINE.

trations show a passenger train crossing the river on this structure.

We have called the movable part of the bridge a swing span instead of saying draw bridge, for the reason that the span, as its name implies, swings about a center and when "open" stands at right angles to the railway line and parallel to the stream. A draw bridge, strictly speaking, is a bridge which is hinged at one end and can be pulled up into a vertical position. The typical draw bridge of old days was used to span the moat about a castle and when pulled up practically made the stronghold into an island. The modern application of the draw bridge idea is to be found in the roller lift or bascule bridges, which are used on a good many of our railways.

The swing span of this bridge is a through girder, which means that the trusses are above the bridge floor and the train runs through between them. The approach span of this bridge is a deck plate girder. This refers to the fact that the girder is below the bridge floor and the trusses are composed of plates and structural shapes riveted together.

The length of the swing span is 341 ft. 4 ins., and its weight is distributed on a turntable and a center bearing in such proportion that the turntable sustains 84 per cent. of the load and the center 16 per cent. The total weight of the swing span is 604 tons. The center bearing is a polished disk made of phosphor bronze, 14½ ins. in diameter, and in shape made something like a magnifying glass.

The bridge is capable of carrying two 136-ton locomotives coupled together

The rail joints at either end of the swing are made continuous by means of a rail lock carrying an easer rail which spans the joint when the lock is closed. A contact rod affixed to the operating lever of the rail lock controls the electric circuit to the bridge signals,



INTERIOR OF SWING SPAN, SHOWING CONTACT FOR ELECTRIC SIGNAL CIRCUIT.

so that when the locks are drawn to open the bridge, the circuit is broken and the signals stand at danger.

In addition to the railroad signals, which are placed at a suitable distance from either end on the main line, the bridge is equipped with U. S. marine signals for river traffic. The total length of the whole structure is 404 ft. 9½ ins.

plete, and Lake Bohio filled up to the required level.

When you see a long article in the daily papers about the canal, don't bother trying to get the endless details into your head; send for a Fitz-Hugh Luther map, and the whole complicated question becomes simplicity itself. The company sell locomotives and cars, but the map is free.

### Pyramid Tool Rack.

In the Lehigh Valley blacksmith shop at Sayre, Pa., there are some very handy tool racks which Mr. E. T. James, the shop superintendent, has had made. The rack has a square base and tapers up from 4 ft. 6 ins. to about 20 ins. on a side, and it stands 4 ft. 5½ ins. high. The rack presents an appearance which would no doubt have been described by Euclid as a truncated pyramid, if he had chanced to visit the shop. The four corner posts are made of 2x2½-in. angle iron, and a number of slats made of 1½x3½-in. flat iron like the rungs of a ladder have been riveted on, each about 6 ins. apart. On the outside of each slat there is a ¾-in. round iron bar formed like the grab iron of a freight car, and at the bottom there is a ¾-in. horizontal plate 9 ins. wide, suitably supported by struts made of ½x2-in. flat iron, placed at regular intervals. The tool rack, as we have intimated, "stands four-square to every wind that

Tower of Babel. Those who have seen the tool rack incline to the opinion that the Eiffel Tower in Paris was the original model, but from whatever source Mr. James drew his inspiration, he has succeeded in getting up a first-class blacksmith's tool rack, and it will stand inspection from all points of view. In fact, when you look at the rack it will not take you long to see through the design, and you will no doubt appreciate the fact that it is economical of space, easily made, and keeps its shape under all kinds of usage.

### Ghastly Apprenticeship.

Apprenticeship is usually regarded as going through the experience by which one learns a trade. Think of a young man being apprenticed to the trade of hangman. In the United States it is the duty of the sheriff of a county to carry out the last rites of the law when necessary, even to the extent of hang-

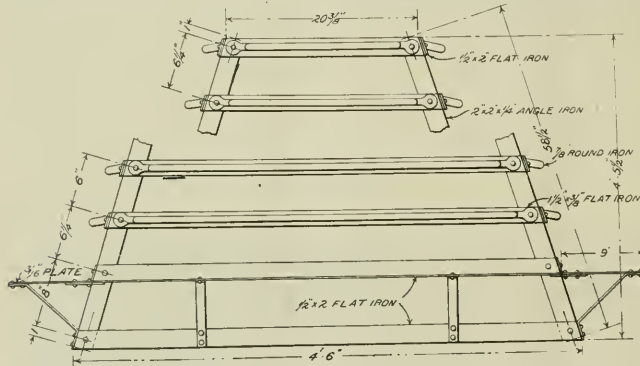

BLACKSMITH'S TOOL RACK—LEHIGH VALLEY.

blows," but that is not exactly the object of the structure. It is, in short, a blacksmith's tool holder, and one of them is placed between every group of four fires. The forges have circular bases, and a corner of the rack points to each one. The flat plate at the bottom serves as a handy place where tools, etc., can be laid out ready for use when any particular piece of work has to be done. It is also a convenient place where small things can be set down out of hand for the time being. The flat slats with the grab iron bars make good holders where a cold set or a swage or like implement can be dropped in, and the rack will swallow them up to the neck and keep them there subject to call. The anvils used in this shop are the Hay-Budden type, made in Brooklyn, and here a good anvil is matched by a good rack.

Some ancient writers consider a building of broad base and with a certain amount of batter to the sides was the form adopted by the builders of the

ing a criminal. This makes the duty of performing the last functions of the law no disgrace. It is a duty that may fall on any citizen who gets elected as a sheriff.

In Europe very different fashions prevail. In most countries a public hangman is appointed, who is a sort of Ishmael among the people. A London paper gives ghastly particulars about the training of a newly appointed hangman and how he went through his apprenticeship in Pentonville prison. The subjects hanged "from the scaffold," says this paper, were lay figures of cloth and sand of different weights. Taylor was told the weight in each case, and he was then instructed as to the requisite drop to be given. The other part of the hangman's training—the pinioning of a condemned prisoner—was even more realistic. For the time being stalwart warders posed as condemned murderers. The experiments are to be repeated daily until Taylor is regarded as "efficient."

### Laboratory Test.

Not long ago a gentleman went into a bookseller's, in Boston, and asked for the current issue of RAILWAY AND LOCOMOTIVE ENGINEERING. He was at once accommodated. As he passed out he saw on a counter, heaped with second-hand books, the notice, "Old Books Rebound." He took up a large and heavy volume and dropped it to the ground. It fell with a loud bang which was heard by all in the shop. The gentleman dropped another and another, and was lifting a fourth from the counter, when the proprietor rushed up, and, in amazement, not to say indignation, asked the meaning of his customer's strange proceeding. "Oh," said the gentleman, pleasantly, pointing to the notice, "I had always doubted it, but now I am quite sure. How came you to fall into such an error? By dropping these ancient literary works to the floor I have demonstrated the fact that age does not impart any appreciable degree of resilience to printed volumes." So saying, he moved quietly to the door with a finger between the pages of his much prized purchase.

### Raising the Wind for a Boat.

An interesting example of the general utility of the Westinghouse air brake pump was given in connection with the raising of the lake steamer "Corey." The work was done by the use of twenty of these pumps. The "Corey" went aground on the shores of Gull Island, Lake Superior, during the severe gale of November last. Early the following month men and pumps were sent by two of the prominent northern railroads to prosecute the work of raising this vessel.

Ten of the 11 in. pumps and ten 9½ in. pumps were distributed along the deck of the steamer and arranged to force air into thirteen of the air tight compartments in the vessel, and while the air was being forced into the compartments by the pumps, the leaks were stopped by boiler makers as fast as they were discovered, either by being patched or by the use of cement. About a week was occupied in accomplishing the preliminary work of stopping leaks.

When the compartments had been made air tight all of the pumps were set to work forcing in air in order to displace the water and raise the vessel. After raising operations had commenced it was found that the boat had come up 4 ft. and sufficient water had been removed to allow the steamer "Houghton" to easily pull the "Corey" from the shore and into deep water. In raising this vessel it is estimated that about 6,000 tons of water were removed by the use of these twenty pumps.



# Our Correspondence School.

In this department we propose giving the information that will enable trainmen to pass the examinations they are subjected to before being promoted. If any of our students fail to understand any part of the instructions, we will gladly try to make them plainer if they write to us. All letters intended for Our Correspondence School ought to be addressed to Department E.

## Manual Labor.

John Ruskin, philosopher and art critic, commenting on manual labor, stated that "we are always in these days endeavoring to separate intellect and manual labor; we want one man to be always thinking and another to be always working, and we call one a gentleman, and the other an operative; whereas, the workman ought often to be thinking, and the thinker often to be working, and both should be gentlemen in the best sense. As it is, we make both ungentle, the one envying, the other despising his brother; and the mass of society is made up of morbid thinkers and miserable workers."

These words were very true in John Ruskin's day, and they are true to some extent in our own day, but the world moves, and it is a matter of pride and satisfaction to the publishers of RAILWAY AND LOCOMOTIVE ENGINEERING to know that among the great body of railroad men in America, the constant perusal of our pages has helped to bring about a happier combination of worker and thinker. In this issue we resume the continuation of the questions and answers used in examinations for promotion on the New England railroads and commend them to the careful study of all railroad men.

## Second Series of Questions.

1. Has there been anything in the past year to interfere with your preparation for this examination?

A.—The answer to this question will depend upon anything interfering or not.

2. Have there been any new signals introduced during the year or any changes on the old ones?

A.—This question will be answered according to the knowledge about signals of the candidate.

3. Have you made any improvement in your method of firing, and have you obtained any better results economically and in smokeless firing during the year?

A.—The answer to this question will also be based on the candidate's experience and progress.

4. Describe the general form of a locomotive boiler.

A.—It is a cylindrical vessel of varying length and diameter, with a fire box in the rear and a smoke box in front. Flue tubes extend from the front of the fire box to the smoke box and carry through the boiler the hot gases generated in the fire box.

5. How does the wide fire box boiler with fire box projecting at each side beyond the wheels differ from the narrow fire box set between the wheels, and what advantage has the wide fire box over the narrow fire box?

A.—The purpose of the wide fire box is to provide a larger grate area than what can be obtained with a fire box set between the wheels. It is also easier to fire properly than a very long narrow fire box.

6. What is a wagon top fire box?

A.—A boiler with that part of the shell above the fire box raised above the level of the waist or cylindrical part of the boiler.

7. Describe a locomotive fire box.

A.—The ordinary fire box is an oblong box secured to the back part of the boiler. It is so constructed that water spaces are provided between it and the outside shell at the sides and the back. The fire box is secured to the outside shell by stay bolts, and at the front end of the fire box is a flue sheet with the flues secured therein. At the bottom part of the fire box the grates are secured in a frame attached to the fire box and beneath these an ash pan. The crown sheet is sometimes supported by bars set on edge but more generally by stays of various kinds.

8. Why have two fire doors been placed in some of the wide fire boxes?

A.—To make it easier to spread the coal over every part of the grates.

9. To what strains is the locomotive fire box subjected?

A.—First to the strains due to high pressure of steam; second, to the strains that arise from varying temperature with the hot water on one side of the sheets and hot flame or, perhaps, cold air, on the other side. Then the changes of temperature act to lengthen or shorten the sheets putting great strains upon the material. Varying temperature of feed water also puts strains upon the fire box.

10. How are the side and end sheets of the fire box supported?

A.—By stay bolts.

11. What purpose is served by the small hole drilled in the outer end of stay bolts?

A.—To give indication by leakage when a stay bolt breaks.

12. In what manner is a crown sheet supported?

A.—Sometimes by crown bars, but generally by stay bolts.

13. What is a bad feature about crown bars?

A.—They impede circulation of water and collect scale and mud.

14. What are the advantages of radial stayed crown sheets?

A.—The radial stays offer little obstruction to the free circulation of the water. They also put less weight on the fire box than crown bars, and do away with the need of string stays to bind the fire box to the shell.

15. How are the inside and outside sheets secured at the bottom?

A.—By the mud ring or foundation ring, as it is sometimes called.

16. Describe the ash pan.

A.—It is a sheet iron pan that conforms to the outline of the mud ring and is secured thereto. There is a door at each end called dampers for restraining or cutting off the supply of air when necessary and to provide means for removing cinders and ashes that the ash pan collects.

17. Why are boilers provided with steam domes?

A.—The dome provides a location for the throttle valve removed considerably above the water level in the boiler. This tends to prevent water from passing into the dry pipe along with the steam.

18. What must be the condition of a boiler in order to give the best results?

A.—It must be kept as clean as possible and as free from scale and mud as circumstances will permit.

19. What is meant by circulation in a boiler?

A.—The circulation is the moving of the water from one point to another inside the boiler. Circulation tends downwards at the cooler parts and upwards close to the heating surfaces. It is strongest about the fire box and arises from the heated water moving upwards and to the stirring given to the water by the steam rushing away from the heating surfaces. There is a theory that the water at the sides and end of the fire box flows downwards at the outside sheet and upwards on the hotter inside sheet.

20. What would be the result if a leg of the fire box became filled with mud?

A.—The fire box side sheet would become overheated.

21. What would be the result if the fire box sheets became overheated?

A.—The sheets would bulge between the stay bolts and would be likely to

crack. If they were overheated by becoming dry rupture might ensue.

22. Why are boiler checks placed so far away from the fire box?

A.—The checks are placed at the coolest part of the boiler so that the fire gases that have been cooled in passing forward may still be able to impart some heat to the incoming water.

23. What part of the locomotive boiler has the greatest pressure?

A.—The steam pressure is uniform throughout, but there is a little pressure due to the weight of the water and that is greatest on the lowest point which is the mud ring.

24. What should be the length of a locomotive smoke box?

A.—The ideas of designers vary greatly on this point. Extension smoke boxes vary from 40 to 60 inches. The most common length on the New York Central Lines is about 65 ins. for passenger and 60 ins. for freight engines.

### Calculations for Railway Men.

BY FRED H. COLVIN.

Following the water in the boiler and tank, let us continue dealing with it after it becomes steam. We very often think of steam as having no weight, and yet, when we come to think about it, all the water that goes into the boiler goes out again in the form of steam. Leaving the air pump and the steam that gets away through the whistles and safety valves, although these amount to more than you might suppose, we will consider only that going through the cylinders and doing work in driving the engine.

The first step is to find the volume of the cylinders, and for easy reckoning we take an engine with cylinders 20 by 24 ins., steam pressure 200 lbs. to the square inch, and 60-in. driving wheels.

Squaring 20, we have  $20 \times 20 = 400$ , and multiplying by 7854, we get 314.16 sq. ins. as the area of the piston. Dividing this by 144 to get square feet, we have 2.18 sq. ft. Multiply this by 2 ft., the length of the stroke, and we have 4.36 cu. ft. as the volume of the cylinder. This means that this number of cubic feet of steam is used every stroke of the piston, or twice during each revolution, for each cylinder, so that four times this, or 17.44 cu. ft., are used for every revolution of the drivers. We can find by calculation, as was shown in the first paper, or by any table of revolutions, that a 60-in. wheel makes 336 revolutions to the mile, so that if we multiply 17.44 by 336 we have the number of cubic feet of steam used per mile by this engine. This multiplication gives 5,859.64 cu. ft., and this is near enough to 5,860 to drop the decimals for convenience in reckoning.

Now the question is to find the weight of the steam per cubic foot.

Call the cut off at half stroke, and from a table we find that for this cut off the steam pressure will average .8466 of the boiler pressure. This has been found by experiment to be the case, so we are safe in accepting these figures for our calculations. With boiler pressure at 200, we simply multiply .8466 by 200 and find that the average pressure is 169.32 lbs.

Looking up another table, called "The Properties of Steam," we find that the weight of a cubic foot of steam at 170 lbs., to weigh .3798 lbs. per cubic foot, and this is near enough to 169.32 to forget the difference. In this same table (Kleinmans Boiler Construction) it tells us that one pound of steam at this pressure occupies 2.63 cu. ft., so that we have our choice of multiplying the total number of cubic feet, 5,859.64, by the .3798, or of dividing by the 2.63.

Taking the latter-choice, because it is a little easier to work out, we find that there are 2,228 lbs. of steam used running one mile at this speed with this engine, and it means that at least that amount of water must be fed to the boiler and made into steam. Allowing for no loss, one pound of water makes one pound of steam, so we can use the terms interchangeably in this case.

The water must be forced into the boiler by the injector, and here is another point that we are too apt to overlook. Few of us realize how much work the injector does or the steam it takes to do it, and this gives us a good chance to find out.

#### WORK OF THE INJECTOR.

According to tests by Strickland Kneass, and there is no better authority on matters pertaining to injectors or steam jet work, a first class injector will feed into the boiler about 13 lbs. of water for every pound of steam used. So to find the steam used in this case we divide the number of pounds, 2,228, by 13, and find that the work of feeding it requires 171 lbs. of steam, and, of course, this much more water in the boiler to make it from. As every pound of steam used by the cylinders must be forced into the boiler in the form of water, we see that the injector takes at least one-thirteenth of all the steam made by the boiler, and some place this as high as one-tenth, or 10 per cent. This varies with the pressure of steam carried, as an injector will throw more water per pound of steam at low pressures than at high pressures. In fact, at high pressures some tests have shown that less than 9 lbs. could be counted on regularly per pound of steam used by the injector.

In this connection, the question is often asked. How fast does the jet of water travel going into the boiler? Taking the same case, we have a good example to work out by assuming that

one injector feeds the engine so that we call it feeding 2,500 lbs. per hour, as this is but little more than the sum of the two amounts we have found.

As there are 231 cu. ins. to the gallon, and a gallon weighs  $8\frac{1}{3}$  lbs., we divide the 231 by the  $8\frac{1}{3}$ , or 8.33, and find that there are 27.73 cu. ins. of water to a pound. So we multiply 2,500 by the 27.73, and get 69,425 cu. ins.

Calling the area of the smallest opening in the discharge tube of the injector one-twentieth of an inch, and this will not be so very far wrong, we are a step nearer the answer, but it requires a little more figuring to get it. In going through the injector this water becomes a small stream or jet only one-twentieth of a square inch in size, so that if we imagine it stretched out in a long stream it would be 20 times 69,425 ins. long, because if it were one square inch in size it would be as long as the total number of cubic inches it contains.

Multiplying 69,425 by 20 gives us 1,388,500 ins. long, or, dividing by 12, to give it in feet, 115,708 ft. long. The injector, then, feeds a stream of water  $1/20$  of a square inch in area by 115,708 ft. long every hour, and assuming that it was running all the time, this would give one-sixtieth of this as the speed of the water in feet per minute, or 1,930 ft. per minute. As a matter of fact, the injector will not be running over one-half to one-third of the time, which would bring this up to 3,860 or 5,790 ft. per minute, the latter being over a mile a minute, as there are 5,280 ft. to the mile. Various calculations made from actual injectors at work have shown that a mile a minute is not especially high for the jet of water to attain, and this is often exceeded. This shows how such calculations are made, and also how you can find out almost anything you want that can be figured, if, after getting a few facts or dimensions to start with, you think out just what to do to make the desired answer come out of the figuring. It is simply a case of good common sense applied to the fundamental rules of arithmetic in most cases.

## Questions Answered

SINGLE ECCENTRIC VALVE GEARS.

(31) J. D. McK., San Francisco, Cal., writes:

I have been told by an engineer that there is a valve motion used on the Southern Pacific, commonly called the Stevenson monkey motion, which works indirect in the go-ahead and direct in backing up. If this is so, please explain. A.—The valve motion to which you refer is the Stevens' valve gear

(not Stevenson), and it is sometimes called by the nickname you refer to. It gives indirect motion when the engine is going ahead and direct when the engine is backing. This is true of practically all single eccentric valve motions. The Walschaert gear is a good example of the same kind. See October, 1905, issue of RAILWAY AND LOCOMOTIVE ENGINEERING, page 439, and also December, 1905, issue, page 535, and an article in another column of this issue. The Joy valve gear is another of the single eccentric valve gears. See our February, 1906, issue, page 55. There are a number of engines on the Southern Pacific which use the Stevens gear. The ordinary Stephenson link motion has two eccentrics, and the motion may be direct for forward and back, or indirect for both, according to the position of the eccentrics and the presence or absence of a rocker. In the single eccentric motions the link practically becomes a rocker for one direction of engine movement and not for the other.

#### QUICK SERVICE TRIPLES.

(32) J. R. C., Syracuse, N. Y., writes:

Will you kindly answer the following in your question and answer column?

1. Why are the quick service triples called by that name? A.—Because in service applications they apply the brakes uniformly throughout the whole train in much quicker time than the present standard quick action triple can do it, and this with only a slight difference in pressure between the front and rear ends of the brake pipe, which reduces to a minimum the likelihood of any shock or jar at the rear of the train.

2. What are its advantages over the old quick triple valve? A.—Besides applying the brakes in shorter time, they use considerably less air; they also stop a fifty car train in about 35 per cent. less distance than the present standard quick action brake, in a full service application. They also make the prompt release of the brakes throughout the whole train more uniform and certain, and this without danger of breaking the train in two when the release is made at slow speeds.

3. Has the quick service triple ever been used in actual service? A.—Yes; a train equipped throughout with this triple was tested last August at a place called West Seneca, on the Lake Shore & Michigan Southern Railway, with most excellent results. Since that time several thousand of them have gone into service, and are giving equally good results.

#### THROW OF ECCENTRICS.

(33) C. W., Coryville, Fla., writes:

If I was to shorten the throw of an eccentric  $\frac{1}{8}$  of an inch, what effect would it have on the valve? Would it not be the same as giving lead? My engine has about  $\frac{1}{8}$  in. lead now, but it takes too

long to get her started. A.—Shortening the throw of an eccentric will have but little effect on the lead, and nearly all upon the travel of the valve. The throw of an eccentric cannot be changed by moving it on the axle, it has the same throw once it is there, no matter what its relation to the crank or where its position on the axle may be. The amount of travel of the valve is lessened by moving the reversing lever towards the center of the quadrant. The position of the eccentrics should never be experimented with except by an experienced mechanic with trammels and other necessary tools who finds the dead centers and locates the exact position of the valves. The readjustment of the eccentric rods may sometimes remedy small defects, but blind experiments cannot do other than make matters worse.

#### SCALE IN BOILERS.

(34) J. F., San Luis Obispo, Cal., writes:

What is the cause of the excessive scaling in boilers on the Pacific Coast, and how does caustic soda act if used in boilers, and how much of it should be used with every 1,000 gallons of water? A.—An analysis of the water on the Southern division of California shows that there are 62 grains of solid matter in every gallon, composed as follows: carbonate of lime, 18 grains; sulphate of lime, 3 grains; carbonate of magnesium, 5 grains; sulphate of magnesium, 16 grains; silica, alumina and iron, 2 grains; sulphate of soda, 8 grains; chloride of soda, 10 grains. Repeated experiments have shown that where the total amount of solid matter exceeds 30 grains per gallon the solution is extremely difficult. The quantity of caustic soda need not exceed 3 ounces per thousand gallons with 6 ounces of lime. The usual method is by treating the water in a separate tank. The treated water increases the tendency to priming in direct proportion to amount of alkali added. The caustic soda and lime are usually dissolved before being mixed with the water in the tank. The frequent use of the blow-off cock helps the action of the caustic soda. There are several remedies on the market for boiler incrustation, the latest being that of the Zephon Chemical Compound Co., at Chicago.

#### NEW YORK NO. 5 PUMP POUNDS.

(35) J. C. McD., Meadville, Pa., writes:

What is it that makes the New York No. 5 pump pound so hard when it is started up and until the air pressure gets up to about 60 lbs.? A.—These pumps are probably applied to engines that carry not less than 200 lbs. of steam, and, having no clearance in the ends of the cylinders, and because the pistons take live steam throughout the entire stroke, they strike hard against the pressure

heads until an air pressure of 60 or more pounds is accumulated in the main reservoir, after which the pistons are sufficiently cushioned to prevent noticeable pounding.

Another thing that helps to make the pistons pound hard, especially on the down stroke, is their weight, which makes it necessary to provide a greater cushioning power.

2. We have had quite a number of reversing stems break in these pumps, and I would be pleased if you would give us your opinion as to what causes them to break. Does the hard pounding have anything to do with it? A.—It is likely that the rods break more on account of the large slide valves, having comparatively large exhaust cavities, which they have to move under the load of heavy steam pressure, and because of the heavy blows they receive from the tappet plates, than from any pounding of the pistons on the pressure heads. Other causes, such as poor material, or rod not made according to specification, may contribute toward the excessive breakage.

#### CROSSED ECCENTRIC RODS.

(36) J. A., Battle Creek, Mich., writes: With crossed rods, what adjustment is made in the valve motion to prevent decrease of "lead" as lever is hooked up? Are not crossed rods avoided as much as possible in locomotive construction? A.—There is no adjustment made to prevent the decrease of lead. It cannot be prevented with an ordinary crossed rod. The common practice is to adjust the valve gear so that there will be a reasonable amount of opening at the end of the piston stroke. Crossed rods are avoided if possible, and are not used in general practice.

#### WALSCHAERT VALVE GEAR.

(37) J. H. E., Bellefontaine, Ohio, writes:

How do you make the changes and set the valves on an engine with the Walschaert valve gear? A.—See illustrated article on the subject on page 166 of this issue.

#### DISCONNECTING SIDE RODS.

(38) S. T., Freeport, Pa., writes:

Would it be considered good practice in disconnecting an eight-wheel engine for a broken middle section side rod, to remove all side rods on disabled side and the main rod also, and run engine with all the rods up on the opposite side? A.—If side rods are removed from one side of an engine they must be removed from the other side also. In the case referred to we imagine you have a 2-8-0 engine in mind, and if the main crank pin is uninjured, the main rod should be allowed to remain in place and also the rods on both sides connecting the front drivers, and the engine could be run similar to an Atlantic type locomotive.

### Walschaert Valve Gearing.

BY JAMES KENNEDY.

The popular favor with which the Walschaert valve gearing is being received wherever it has been recently introduced, gives indication that it is in every way better suited for the heavy modern locomotive than the shifting link motion so long in use. Some difficulties are being experienced in adjusting the gearing in case of repairs and alterations on locomotives, but the movable points about the gearing are very simple, and, as a rule, require little or no readjustment. In comparison with the Stephenson shifting link there is little variation in the action of the Walschaert gearing, whereas, as is well known, the variations in the Stephenson gearing are of rapid and complex growth.

In adjusting the Walschaert valve gearing all that is necessary is to place the engine on either of the dead centers.

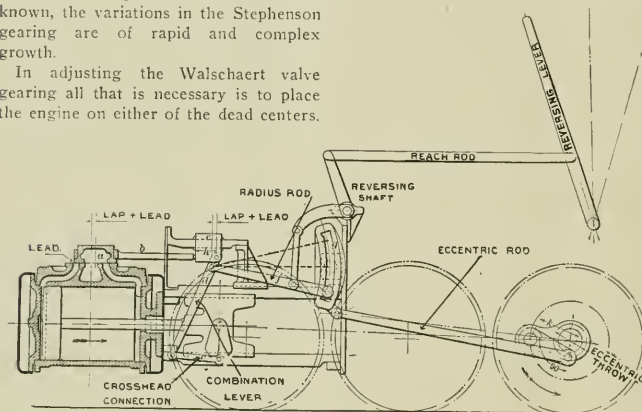

DIAGRAM OF WALSCHAERT VALVE GEAR.  
(Reproduced from Baldwin Locomotive Works Catalogue.)

The length of the eccentric rod should then be so adjusted that in moving the reverse lever from end to end of the quadrant the valve should remain perfectly still in its position while the radial bar moves from end to end of the link. Any movement of the valve shows that the eccentric rod is too long or too short, as the case may be. This should be tried at both centers and if the valve remains motionless the eccentric rod is of correct length. It is well, before making any change on the length of the eccentric rod, to see that the valve rod is of the proper length. This can readily be determined by marking the position of the valve at both dead centers and lengthening or shortening the valve spindle to equalize variations, if any. The amount of lap or lead is then determined by the leverage in the combination attached to the crosshead. It will be readily seen that by reason of the eccentric crank being set at right angles to the main crank, and the eccentric rod and valve connections being of the proper length, the slide valve, unattached to the crosshead connection, would be in the center of the valve seat with, perhaps, the little divergence from

the exact center arising from the slight angular advance of the eccentric rod. Although that the valve is on the center the distance to be moved amounts to whatever the lap and lead may be, and the proportion of the combination lever with the short leverage connection with the crosshead can readily be determined by moving the valve to its proper position, and then with the valve spindle and radial bar coupled, the length of the lower connection from the crosshead to the combination lever can be readily determined.

It will thus be seen that if the eccentric rod and connecting rod between the crosshead and combination or lead lever, as it might very properly be called, were

has the pernicious effect of disturbing the true location of the radial bar and paves the way for organic defects, and should be avoided for no other reason than that liners never fail to lend themselves to the loosening of substantial bearings, and one of the best features of the Walschaert valve gearing is the opportunity that the parts afford for broad and massive bearings which, with the lessened number of working joints, give the apparatus a most desirable degree of stability.

It may be added that in adjusting valves with the Walschaert gearing while it is well to begin the operation with the reverse lever at the extreme ends of the quadrant, it is necessary to finish the work by careful experiment at the point of cut-off at which the locomotive will be expected to do the greater part of its work, for, while the lead remains a fixed quantity, it will be found that there are causes which produce variations in all mechanical movements that have their origin in circles or parts of circles and are transferred to a reciprocating or linear motion.

One of the most conspicuous defects noted in the operating of locomotives during the past winter has been steam blowing through stuffing box glands. Besides being a serious waste of steam the leakage is a dreaded source of danger since it frequently obscures the track ahead and the signals that conserve safety. We have heard frequent discussions of the matter by the men responsible and they have generally devoted their attention to methods of improving the packing. The fact is that the packing is nearly as perfect as it can be made and that the real defect is in the rods that work in the packing. They are roughly turned and tear the packing from the start. Railroad men ought to devote more attention to the finish of the rods. Those who use piston and valve stem rods finished on machines made by the Norton Grinding Co., of Worcester, Mass., will find very little annoyance from leaky packing.

Greene, Tweed & Co., the makers of Palmetto air pump packing, have moved into more commodious quarters on account of the steady increase of business. Their new location is at 109 Duane street, New York City.

made adjustable by substantial turnbuckles or other movable devices, the setting of the Walschaert valve gearing and the retaining of the valve in its proper position would be a matter of easy accomplishment. It may be noted that a locomotive constructed at Taunton, Mass., and put in operation at the Centennial Exhibition, at Philadelphia, in 1876, with the Walschaert gearing moving the valves, was fitted with an adjustable turnbuckle on the eccentric rod, while another locomotive, exhibited at St. Louis in 1903, has a similar device attached to the crosshead connection with the lead lever. It is to be hoped that our locomotive builders will soon produce a locomotive with eccentric rods, valve rods and crosshead connections all readily and securely adjustable in length.

Meanwhile, in adjusting the eccentric rod, it has become a practice in some shops to change the position of the bearings suspending the link as in the case of the eccentric rod being too short a liner between the guide yoke, or bearing brace, and link bearing casting will shorten the distance between the oscillating link and eccentric crank. This

The Chinese have many moral maxims that might be profitably introduced into American practice, if that would influence public morals. Yong Chen, one of their philosophers, when asked to take a bribe, and assured that no one would know it, answered: "How so? Heaven would know, Earth would know, you would know, and I should know."

# Air Brake Department.

CONDUCTED BY J. P. KELLY.

## Diagram of Pipe Connections—E T Engine and Tender Equipment.

So popular has become the E T engine and tender brake equipment, that already nearly all the new engines now being built at the various locomotive works are being equipped with it, and its advantages over the older equipment

cut-out cock is to prevent the loss of main reservoir air whenever it is desired to make quick or temporary repairs to any part of the brake apparatus, if these should be found necessary or desirable after the system has been pumped up. It has the maximum pressure head of the pump governor connect-

off to the feed valve pipe, there is a pipe strainer. This strainer being placed where it can protect the feed valves for the automatic and the independent brake valves from dirt and other foreign substances, enables them to operate without any occasional annoyance from dirt, keeps them clean, reduces wear, and

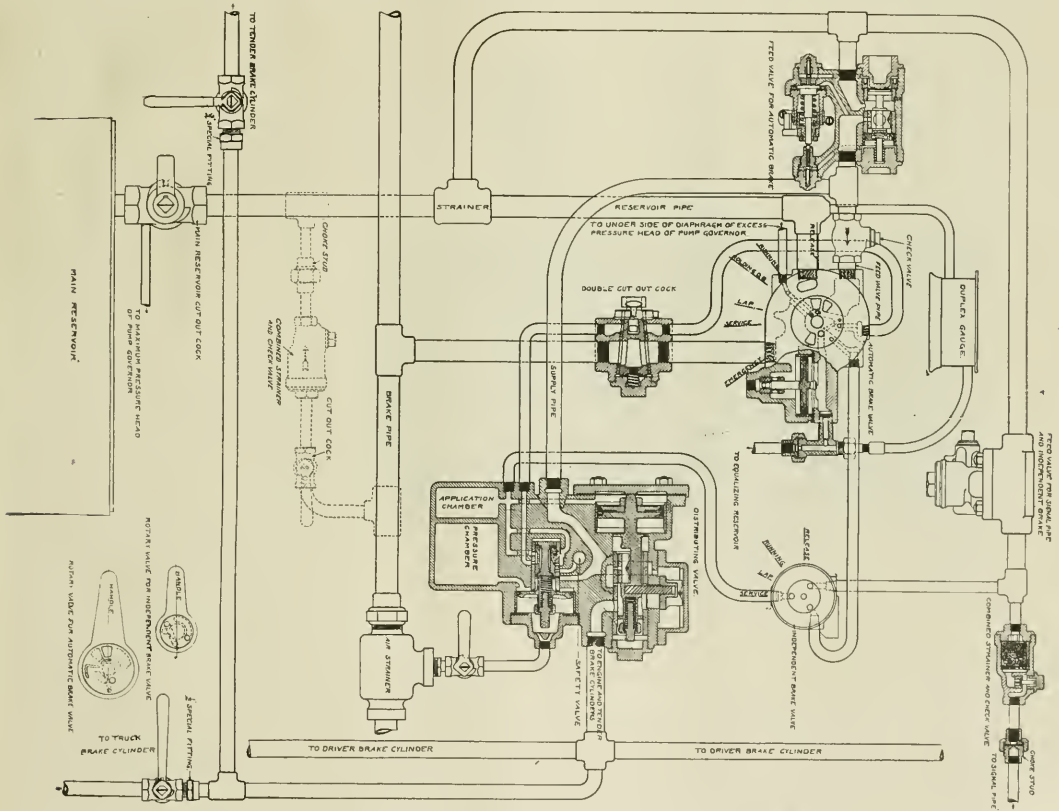

FIG. 1. PIPE CONNECTIONS "E T" ENGINE AND TENDER EQUIPMENT.

are commencing to be realized to a large degree.

The illustration, Fig. 1, shows the pipe connections, and the various valves sectioned so as to show their internal construction.

By reference to this illustration it will be observed that there is a cut-out cock placed in the main reservoir return pipe, so located that, when desirable, the main reservoir may be cut out from the rest of the equipment. The object of this

tion made to it in such manner that this head is never cut out, and, consequently, the pump governor never loses control of the pump. When this reservoir cut-out cock is turned to cut out the main reservoir, it opens a port leading from the return pipe, on the brake valve side, to the atmosphere, so that the brakes will apply, thus necessitating the opening of this cock before proceeding and after repairs are completed. At the tee, where the return pipe branches

prolongs the time for cleaning and repairs.

The direct main reservoir connection to the automatic brake valve base is plainly shown on the figure, and it should be observed that the port to which it connects is large, much larger than it is in the G6 valve, so that when the handle is placed in train brake release position main reservoir air has a free flow into the brake pipe up to the capacity of this pipe. Experience

proves that this large port opening causes a quicker and more satisfactory release of all the brakes on extremely long trains; also a quicker recharge of the auxiliaries, something that materially increases the degree of safety with which trains may be handled on long, heavy grades. The branch pipe connecting to the main reservoir pipe at the tee strainer connection conducts main reservoir air to the feed valve for the automatic brake, and to the feed valve for the independent brake and the train air signal pipe. The feed valve for the independent brake, as will be understood from this, also serves for the air signal, thus virtually doing away with the feed valve for this

distributing valve to supply the engine and the tender brakes both in automatic and in independent brake applications. Between the supply pipe tee connection to the feed valve pipe and the automatic brake valve there is placed a check valve whose function is to prevent the possible backward flow of brake pipe air during heavy independent brake applications. If such backward flow were to occur, it would have a tendency to apply the automatic brakes.

A double cut-out cock is placed in the brake pipe below the automatic brake valve, which is used to cut out this valve when engines are double-heading. It will be observed that there is a pipe connection from the automatic brake valve

connecting the independent brake valve to the automatic brake valve, when the handles of both brake valves are in running position.

The brake pipe is connected to the brake pipe pressure chamber of the distributing valve, and the pressure chamber of the reservoir is charged in the same way that an auxiliary reservoir is when the triple valve is in release position.

A cut-out cock is placed in the branch pipe leading from the main brake pipe to the distributing valve, so that the latter may be cut out, if occasion requires it, the same as the triple valve is ordinarily cut out when there is any defect in the brake apparatus.

Hose connections are required in the brake cylinder branch pipes leading to the engine truck brake and the tender brake cylinders. A  $\frac{1}{2}$  in. cut-out cock with a special  $\frac{1}{2}$  in. fitting is placed in the branch leading to the engine truck brake cylinder; while a  $\frac{3}{4}$  in. cut-out cock and a  $\frac{3}{4}$  in. special fitting is placed in the branch leading to the tender brake cylinder. The cut-out cocks are for the purpose of cutting out, or isolating, the brake cylinder should this be necessary for any cause; and in the special fittings there is a choke which will prevent the loss of the other brakes should a hose burst during a brake application.

The pipe connection between the brake pipe and the main reservoir, shown in dotted lines, may be used where dead engines are hauled in trains to charge the main reservoir, to permit of operating the brakes the same as those on a car.

In such cases by opening the cut-out cock air from the brake pipe will flow through the check valve and charge the system, and this check valve will prevent its backward flow into the brake pipe when the brakes are being applied. This arrangement, however, for handling dead engines will seldom if ever be used, and is only a suggested one in case it is thought desirable to provide it.

The brake valves, as may be seen, are of the rotary type, and the various positions for the handle of each are shown on the drawing, as well as the arrangement of the various ports in the rotary valve seats. In the lower right hand corner are shown the plans of the rotary valves.

The brake valves, their seats and rotaries, will be more fully illustrated and described in a future article devoted to them alone, but for the present they may be dismissed with a brief description covering their new features.

As stated in a previous article, the E T equipment is designed throughout so that when once installed upon a locomotive all valves may be removed

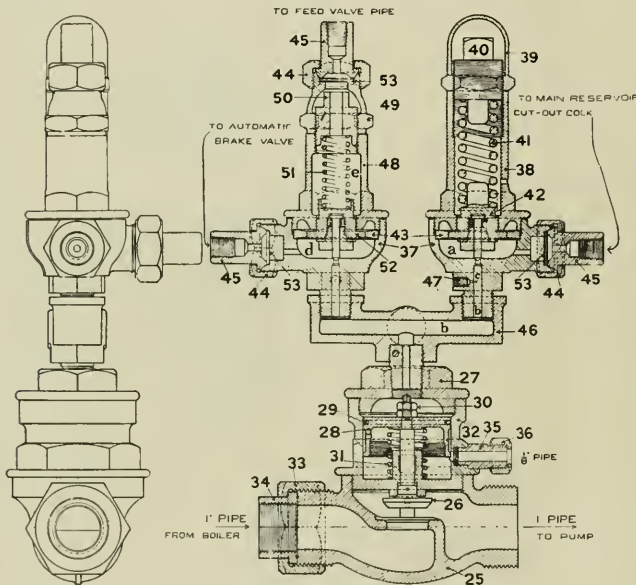

S-D-4 PUMP GOVERNOR.

apparatus, making one less part necessary for the train air signal.

In the pipe leading to the signal apparatus there is a combined strainer and check valve, and a little beyond this a choke of the same size as that used with the older air signal pressure reducing valve. The strainer in the signal pipe prevents any possible dirt getting onto the seat of the non-return check or of obstructing the opening through the choke. The duty of the non-return check in the signal pipe is to prevent the possible backward flow of air from the signal pipe, when the independent brake valve is being used, that might cause the whistle to blow.

The supply pipe to the distributing valve is connected to the feed valve pipe at a point between the feed valve and the automatic brake valve, and through this pipe main reservoir air flows to the

through the double cut-out cock, to the distributing valve. This connection is ordinarily closed when the cut-out cock is turned to cut in the automatic brake valve, and it is opened when turned to cut out this brake valve. With the handle of the automatic brake valve on lap position—where it should be carried when this valve is cut out in double-heading—there is a direct opening from the exhaust port of the application chamber of the distributing valve to the atmosphere through this pipe connection.

The pipe connection from the independent brake valve to the distributing valve is made direct to the application chamber and this chamber is in direct communication with the atmosphere when the handle of the independent brake valve is in release position; it is also in communication with the atmosphere through this pipe and the one

and replaced without disturbing any pipe joints; hence, when necessary to remove a brake valve for repairs all that is necessary to do is to loosen four bolts and take the valve from the permanent base. The feed valves, and the distributing valve also, may be removed and replaced without disturbing the piping. This feature of the piping cuts down appreciably the time and labor required in making repairs, when these are necessary, and obviates the necessity of holding the engine.

Because of the piping arrangement of the brake valves, the engine and the tender brakes may be applied or may be released independently of the train brakes, or the latter may be applied or released independently of the engine brakes.

This feature of the new equipment enables the engineer to handle long trains to much better advantage than formerly, as the engine brakes may be held applied while the train brakes are being released, thus preventing shock and danger of breaking in two.

Also because the brakes may be alternated on the train and the engine, trains may be handled on heavy grades much more satisfactorily than formerly, making a more uniform descent of the grade without danger of overheating the tires.

When the handle of the automatic brake valve is moved to the extreme left, the train brakes are released, and the engine and tender brakes are held applied. Returning the handle to running position releases the engine brakes. The brakes on the engine may be graduated off by moving the handle to running position, releasing a portion of the brake cylinder air, then to driver brake holding position, repeating the operation, if circumstances require it, to produce the required degree of graduation. The engine and train brakes are applied simultaneously, in automatic applications, the same as with the G6 brake valve.

In cases of double-heading, the brakes on the second engine may be released and reapplied, independently of the leading engineer, with the independent brake valve, so that at any time when desirable, such as when drivers are sliding or tires are overheating, the driver brakes may be released and then when desired may be reapplied.

When switching the independent brake valve may be used, and the brakes graduated on and off the same as is now done with the straight air brake valve.

The brake valves are provided with an oil bath for the rotaries so that they may always be kept in good condition so far as lubrication is concerned; and because of the larger and better arranged ports such a thing as a hard working valve will not be experienced.

The distributing valve, no doubt, will prove the most interesting part of the ET equipment, since it is the distinguishing feature, but a full description of this piece of mechanism, together with diagrammatic illustrations of it in its various positions will be given in a future number. In this it will be sufficient to say that the pressure chamber is charged up in the same manner that an auxiliary reservoir is, and that it responds to a reduction in brake pipe pressure so as to admit air from the pressure chamber to the application chamber, the amount admitted depending on the amount of brake pipe reduction made. The pressure in the application chamber acts upon the piston of the supply valve so as to force it and the supply valve to the right. The

chamber, so that in all service applications excessive brake cylinder pressure is quickly blown off and in emergency application is blown down gradually, very slowly at first and then with increasing rapidity until the limit of adjustment is reached.

An important feature in connection with the distributing valve is the fact that when the handle of the automatic brake valve is thrown to the emergency position, the brake valve equalizing reservoir is connected to the application chamber of the distributing valve increasing the braking force 20 per cent. This means that in an emergency application the driver, engine truck and tender brake cylinder pressure is augmented 20 per cent. over what is obtainable in a full service application, and



SOUTH AFRICA--ARMORED TRAIN ON TEMPORARY TRESTLE. WRECK OF STEEL BRIDGE SHOWING BEYOND.

supply valve in moving to the right opens the communication between the main reservoir and the brake cylinders and admits air to them until the pressure is slightly greater than that in the application chamber; then the piston and supply valve move back and cut off the supply to the brake cylinders.

Thus it will be seen that the brake cylinder pressure is dependent upon the pressure in the application chamber and not, as formerly, upon the size of an auxiliary reservoir or the length of the piston travel. Also that if leakage occurs in the brake cylinders the supply valve will open automatically and supply the leakage, so that brakes will not leak off on the engine and tender unless this leakage is greater than the capacity of the pump and the main reservoir can keep up. As shown on the drawing, the distributing valve is in release position.

The brake cylinder safety valve is screwed into the side of the distributing valve, and communicates with the appli-

cation chamber, so that a much shorter stop from high speeds, without danger of wheel sliding, is sure to result.

The use of the various positions on the brake valves for the handles, is described in the December, 1905, number.

This equipment is now working on several hundred locomotives engaged in all classes of service, and one of the beauties of it is that no changes or alterations in it are necessary to adapt it to any kind of service.

#### The S-D-4 Pump Governor.

Not much in the way of explanation is needed to convey a clear idea of the construction and operation of the new pump governor used with the E T equipment.

The illustration, page 108, shows the construction, and from this figure, the difference in design of this governor from that of the ordinary duplex pump governor, will be seen to be confined exclusively to one of the pressure tops.

or diaphragm portions; the other pressure top, the siamese fitting and the body portion, containing the piston and the steam valve, remain the same as in the older governors.

Referring to the figure, it will be seen that the modified pressure top has two pipe connections, one to the feed valve and one to the automatic brake valve; also that the "excess pressure" spring 51 is much lighter than the regulating spring 41, contained in the other pressure head; and that the regulating screw 50 is not so long as the regulating screw 40.

The operation of the S-D-4 pump governor is as follows: The main reservoir pressure top is piped to the main reservoir cut-out cock in such manner that the governor will control the pump in the ordinary way when the maximum main reservoir pressure for which it is adjusted has been obtained, whether the main reservoir cut-out cock is open or closed.

With the handle of the automatic brake valve in train brake release, in running, or in driver brake holding position main reservoir air enters the excess pressure top at chamber *d*, underneath the governor diaphragm 52; and brake pipe air enters chamber *e*, above this diaphragm, through the feed valve connection to the lock nut 49. As may be seen, the diaphragm 52 has both air and spring pressure above it, and air pressure only under it.

Assuming that the brake pipe feed valve is adjusted to maintain 70 lbs. pressure, it will cut off the supply of air to chamber *e*, when this amount of air pressure has been obtained in the feed valve pipe. Adding the excess spring pressure (20 lbs.) to the chamber *e* air pressure of 70 lbs., it will be noted that a total of 90 lbs. pressure will be had pressing downward on the diaphragm 52. With the automatic brake valve handle in any one of the positions named above the pump will continue to work, and to increase the pressure in chamber *d*, under the diaphragm 52, until it reaches 90 lbs., or a trifle more, when this diaphragm together with its pin valve will be raised, and air will flow down on top of the governor piston 28, causing it to seat steam valve 26, and thus control the pump, maintaining the proper brake pipe and excess pressures.

When the air pressure in chamber *d* falls below 90 lbs., diaphragm 52 will force the small pin valve to its seat, cutting off the flow of air to the governor piston, and the air remaining in the chamber above this piston will quickly escape to the atmosphere through the passage *b* and small port *c*, and allow piston 28 and steam valve 26 to rise and permit the pump to work as usual. If the adjustment of the feed valve be

changed so as to carry any other brake pipe pressure than 70 lbs., it will easily be seen that when the main reservoir pressure in chamber *d* is 20 lbs. in excess of the air pressure in chamber *e*, or, to put it another way, is a trifle greater than the air and spring pressure combined, the governor will operate and stop the pump. In this way the new governor automatically maintains the desired excess pressure, the amount of which may be regulated to suit conditions by simply screwing, up or down, the regulating screw 51.

With the handle of the automatic brake valve on lap, in service application, or in emergency position, the excess pressure top is cut out, and the pump will be controlled by the main reservoir pressure top.

By properly adjusting both governor tops, the proper excess pressure is automatically maintained regardless of what the feed valve adjustment may be, and at the same time high main reservoir control is had.

#### Suggested Place for Meeting of Air Brake Association.

The following communication, received by the secretary of the Air Brake Association from a member residing in Russia, in reply to the circular requesting that a place be suggested for holding the next annual convention, will no doubt be of interest to our readers.

In answer to your invitation to suggest a place for a meeting of the next annual convention, I would respectfully suggest, that the next place of meeting be held at St. Petersburg, as it certainly answers all requirements, which you suggest in your circular of September 1. In the first place, this city has never been favored with one of your conventions, neither has any city in the vicinity of same.

The hotel accommodations are more than adequate and the rates are more reasonable than any hotel rates at which any of the conventions heretofore have been held. Meeting halls are also plentiful, besides there has been a new hall just opened on Bolschoy-Konoushina. This hall may be had for fifty dollars a day, from six o'clock in the morning till 5 o'clock the next morning, including lights. A banquet hall is in the same building, which, of course, is included in the rent, only the meals must be paid for extra. However, by taking this hall continuous sessions might be held. If the executive committee should decide to use this hall, the writer might arrange to have same furnished gratuitously for a week.

The accessibility of St. Petersburg is second to none. Those members in the Eastern States could come by way of Europe, those of the Western States could come by way of Japan and Si-

berian Railroad. In this way all the members would have equal distances to travel and no particular section would be favored.

In order to internet the monotony of the meeting, the members might enjoy some spectacles, which they probably had never had the pleasure of seeing before, such as having a troop of Cosacks dash down the street into a crowd of people, knocking them right and left, riding over them with their horses. Then such things as throwing mantel-pieces and other bric-a-brac from the third and fourth story windows at the troops, with the occasional report of a bomb. These are all sights worth seeing, and when once seen will be remembered for a lifetime, and I do not think that the executive committee of the Air Brake Association should deny its members of such an exciting treat; and this all can be brought about by the executive committee simply selecting St. Petersburg as the meeting place of the next annual convention.

I trust that you will take this matter up at once with the executive committee and also have the writer appointed on the committee of arrangements, so that he can immediately set to work, getting rates at hotels, getting the date for the hall as well as having the streets decorated during the week of the Air Brake Association convention. If they should also be kind enough to appoint the writer on the entertaining committee, he would endeavor to see that sufficient bombs were on hand in order to make the convention week exciting and lively.

I am in hopes of receiving a letter from you at an early date advising me that the executive committee has unanimously decided to hold the next annual convention in 1906 at St. Petersburg, Russia. In the meantime, I remain,

J. K. V. LENVENSKI.

The Union Switch & Signal Co., of Swissvale, Pa., have issued another of their standard catalogues. It comprises sections 16 and 17, and is devoted to indicators, annunciators, insulators, track drilling machines, trunking, etc. This latter word, trunking, refers to the yellow pine boxes in which pipe and wire leads are laid. The catalogue is clearly illustrated with half-tones and line cuts, parts are numbered for ordering, and the prices of each are also given. The company have not issued the sections of their catalogue in what may be called chronological order, and this one completes the 1902 edition of electrical appliances. Other sections of later years have already been issued as the requirements of a constant and heavy business demanded. Those who desire to secure copies of sections 16 and 17 should apply direct to the company.



In the manufacture of reamers there are several firms whose work is of surpassing excellence, among whom the old established firm of Pratt & Whitney, of New York, has done much to bring the making of reamers as near perfection as can be expected. The defects that we have briefly pointed out in our editorial column, page 159, of this issue, are not the faults of the manufacturers, but are owing to the shortcomings of those entrusted with the keeping of machine shop reamers.

### Rotary Snow Plow.

The rotary snow plows which are used in the mountains and elsewhere on the Canadian Pacific Railway, were built at the Angus Shops, in Montreal. The front of one of these plows is shown in the half-tone. We are indebted to Mr. Lacey R. Johnson, assistant superintendent of motive power, for the photograph, from which our illustration is made, and for the data concerning the machine itself.

The plow is built on a frame composed of heavy steel channels, well trussed top and bottom, and carried on two heavy trucks, somewhat similar to the heavy tender trucks used on the C. P. R. The front one of these trucks is equipped



ROTARY SNOW PLOW BLADE.

with ice cutters operated by compressed air. The main snow cutting wheel is composed of a large wrought iron ring carried on a main shaft on which two sets of radial knives are fixed, the outer knives being about twice the length of the inner ones. Each knife is hung on a center bolt and bent over to form a cutting angle on two sides. Behind the knives on the same shaft a large fan is placed, the snow being cut up or shaved off, so to speak, by the cutting wheel and falls down, and is sucked into, the center of the fan. As the fan revolves, the snow is thrown out by centrifugal action through an opening in the top casing. This top casing has a sliding cover which can be moved to suit the direction in which the fan throws the snow. By reversing the engine the snow can be made to go out on whichever side of the track desired.

The knives on the cutting wheel are protected to a certain extent, and the area of the snow to be operated upon is determined by a large steel shield having a cross section somewhat greater than the largest car on the road, in order to allow clearance between the car and the snow, and wide enough to allow for the longest car going easily around a curve between walls of snow. The cutting wheel is driven by means of miter wheels on the main shaft and on

the crank shaft of the engine. The engine itself is composed of the standard 17x24 in. cylinders, of what is called on the road S. A. class engines. The link motion, rods, etc., are all standard details of this class of engine, and so also is the boiler. The whole is mounted on channel frames, as before mentioned. Everything is housed in for the protection of the operators, and there is a cupola on the front to enable the roadmaster, or whoever is in charge of the machine, to see where he is going, and what he is doing. The plow carries behind it one of the standard S. A. Class locomotive tenders. A rotary plow is not used in anything like the same manner as an ordinary wing plow is used, and it does not butt into snow drifts. The rotary is pushed through the snow by a locomotive at a speed sufficient to let it do its work properly and to enable it to handle the depth and kind of snow to be attacked.

In the mountains where snow slides occur on places not protected by sheds, they pile themselves up on the railway from 6 to 25 ft. deep and often half a mile long. These slides come down generally when a thaw takes place, or when mild weather makes the snow so heavy that it breaks itself away from the mountain tops, and in cases like this the rotary has to do some real work, as was more fully explained last month.

It is proposed to drive a tunnel through a part of the Alleghany Mountains for the Pennsylvania Railway. Two routes are said to be under survey, one involving a nine and the other an eleven mile tunnel. It is stated that, while the undertaking would equal the Simplon tunnel in magnitude, the rate of construction would be much more rapid, as the height of the mountains above would not be too great to prevent the driving of intermediate shafts.

### Milk in Tank Cars.

One of the earliest economies introduced in the distribution of petroleum was the use of tanks as receptacles instead of barrels in shipping it.

The idea was next applied to beer. Some years ago the project of beer trains or bock trains, as they are called,

from Germany to France was laughed at as impracticable. But a bock service was established between Munich and Paris, and now thousands of gallons of Bavarian beer are shipped three times a week from the brewery yards to the Paris brasseries direct without breaking bulk, and to the success of the project is due the general substitution of beer for wine as a drink among Parisians.

The last fluid to be carried in tank cars is milk. The practice grew up in Denmark, and for some months milk has been shipped long distances, and recently all the way to Berlin in such cars.

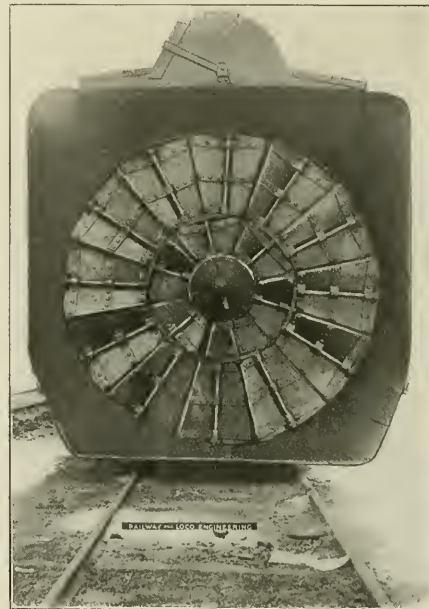

ROTARY SNOW PLOW HEAD ON.

The tanks are not boiler plate cylinders, but wooden casks, each of 210 cu. ft. capacity, two of which are fastened to the floor of a covered freight car. Berlin gets much of its milk from Denmark, and the old fashioned tin cans are alike cumbersome, expensive and subject to damage. By the use of tank cars for milk the cost of handling is much reduced.

The two Western States which have the largest milk shipping interests are Illinois and Wisconsin. For cans tanks have been and are being substituted, and it is reported that the experiment has been entirely successful.—N. Y. Sun.

Many men are wise without being learned; many men are brim full of education and empty of wisdom.

### Radius Planing.

There is a very neat rig which can be fixed up on a shaper by which it can be made to do radius planing or radius shaping, whichever it may be called. The sketch which is here reproduced was suggested by the easily applied device seen in the Pennsylvania Railroad shops at Wilmington, Del. The idea is not

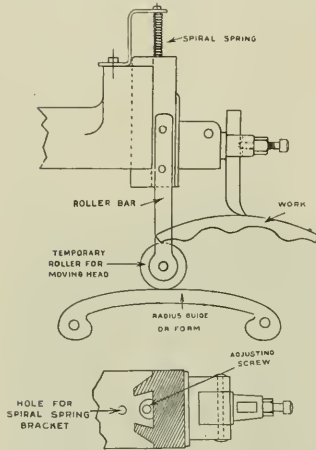

RADIUS ATTACHMENT ON A SHAPER.

new, but each shop staff has practically to design it for their own use, and make it suit local conditions.

In this case the adjusting screw has been removed and a Z-shaped bracket is bolted temporarily on the top of the head. A spiral spring is put under the top arm of this bracket and the lower end of the spring rests on the apron and pushes it down all the time, and as the adjusting screw has been taken out, the weight of the moving parts and the pressure of the spiral spring is supported on the roller with bar temporarily bolted to the side of the apron. The roller runs on a radius guide, or form, which is made with whatever contour the point of the tool is to sweep out. The radius guide is bolted up to the side of the table and the work adjusted to suit. The head of the shaper has, of course, a horizontal motion and the apron, tool holder, etc., is given a varying up and down motion by the roller as it runs on the radius guide. The combination of these motions causes the point of the tool to cut over a surface similar to the upper edge of the radius form. Care must be taken not to give the shaper head so much horizontal travel that it will permit the roller to drop off the end of the radius guide. The arrangement at Wilmington was got up by Mr. W. J. Feeney, who is a machinist in the shop. A great deal of work one way and another can be done by some such device as this where the principle of radius planing is involved.

### Impressive.

We had a conductor on the Pa named William Ford, who was the most pompous man in the Quaker State. The boys called him Windy Bill on the sly. One day he walked into the waiting room at a station where my wife and little boy were waiting for a train. As he passed through every one made room for him and tried to show attention. My little boy watched him until he disappeared and then whispered to his mother, "Ma, was that God?"

### Zephon.

The care of boilers is a subject of great importance, and nowhere is it greater than on our busy modern railroads to-day, and it is, therefore, with interest that we recently read a small pamphlet on this subject, issued by the Zephon Chemical Compound Company, of Chicago.

Concerning the Zephon boiler compound, we are told that it is in powdered or granular form, and contains nothing injurious to boilers or to valves or packing. It softens and removes scale, and does not cause the water to foam. It is said to neutralize the injurious action of acid, sulphur or mineral matter in the water and will prevent oxidation of iron and corrosion in every form. It is put up in 100, 200 and 300 lb. drums, and samples may be had on application to the company, who are at all times ready to explain its action and the way in which to use it.

One railway company using the Zephon compound considers that it has

who is interested enough to drop them a postal card asking for one. They will, if requested, send a sample, and if desired, a man to see that it is used so as to secure the advantages claimed.

A conspicuous departure in the lighting of canals is that of the Welland canal near St. Catherine, Ontario. Over 600 alternating current series arc lamps have been provided by the Canadian Westinghouse Company and these have been in operation for the past few months and have given splendid service. This installation as a whole redounds to the credit of the Ontario government, as well as to the consulting engineer, Mr. R. J. Parks, under whose direction the complete plant was installed.

### B. & M. Consolidation.

Not long ago the Boston & Maine Railroad procured from the American Locomotive Company six consolidation engines for freight service, which were built at the Schenectady works of the company. These machines each weigh in working order about 170,000 lbs., and with tender the total amounts to about 277,300 lbs.

The feature which at once strikes an observer is the Walschaert valve gear, the piston valves and the by-pass arrangement. The engines are similar to those previously supplied to the B. & M., but are somewhat heavier, because of the increased size and weight of some of the details now used. The piston valves are placed immediately over the cylinders, which is a convenient ar-

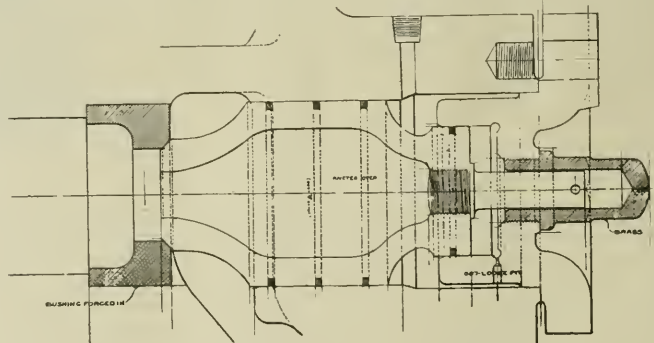

SECTION OF RELIEF VALVE, B. & M. CONSOLIDATION.

saved fuel by reason that the boilers have been kept clean and the heat from the coal has been used in boiling water and not in raising the temperature of hard and refractory scale. The life of the tubes in these boilers has also been prolonged. The compound has been used by the Illinois Central Railroad, and has given satisfaction on that line.

The Zephon Company will be happy to send a copy of their pamphlet to anyone

rangement for the attachment of the Walschaert motion. It will be observed by reference to our illustration that this placing of the main valves avoids the necessity for rockers in the valve motion. Mr. Henry Bartlett, superintendent of motive power of the Boston & Maine, gives three reasons for adopting the Walschaert gear on these 2-8-0 engines. This gear, he says, offers an opportunity for a saving in weight over

the Stephenson motion. The use of this gear is expected to result in a material reduction in roundhouse repairs, and the whole arrangement is very convenient for inspection, rendering it unnecessary for men to go under the engine in order to make a careful examination of the vital parts. The valve gear, like other forms which do not use two eccentrics is direct or indirect according to whether the engine is going ahead or backing up. In the go-ahead direction the valve is moved by direct motion, but as soon as the reverse lever pulls the link block to the top of the link, in order that the engine may back up, the motion becomes indirect. These locomotives have been assigned to through freight service between Boston and Rotterdam, N. Y., on the Fitchburg

made with two hollow valves with packing rings, one valve at each end, sliding in cylindrical chambers. The by-pass valve is kept in place by reason of the fact that the area acted on by the live steam, which comes to its open or cored out end through the cylinder port, is compelled to act upon an area less than that upon which, at the other end, live steam introduced from the steam chest is able to act. The by-pass is thus under pressure of live steam from both ends, but it is kept shut just as a throttle valve is with its greater area on one end and its lesser area on the other.

In the case of the by-pass valve, if compression in the cylinder should at any time rise higher than live steam pressure, it would, though acting on the

of the valve opposite the seat, after which modification the arrangement has given entire satisfaction.

The boiler is a straight top one of ample size, being 66½ ins. outside diameter at the smoke box end. The barrel is composed of two courses, and 16-ft. tubes are used. These tubes give a heating surface of 2,716.87 sq. ft., there being 326 of them, No. 12 B.W.G. The fire box gives 144.2 sq. ft., so that the total heating surface is 2,861.1 sq. ft. The grate area is 46½ sq. ft. The roof sheet is level, though the crown rises slightly toward the front. The throat sheet is vertical, but the back sheet slopes forward about 12 ins. from the perpendicular. The staying of the crown sheet is radial.

The tank is made with a water bot-

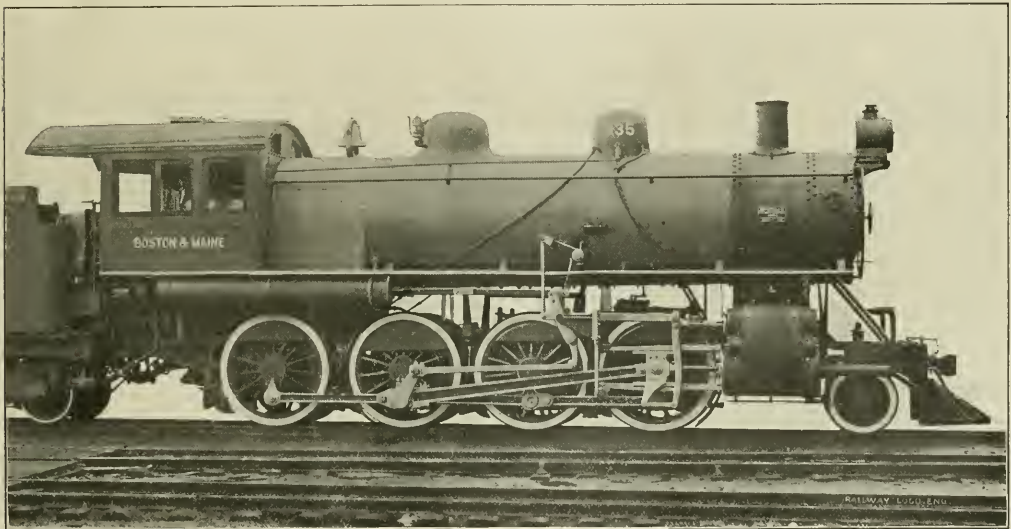

BOSTON & MAINE CONSOLIDATION WITH WALSCHAERT VALVE GEAR.

Henry Bartlett, Superintendent of Motive Power.

American Locomotive Company, Builders.

division. They have not been in service long enough to establish a record concerning the valve gear, but we understand that those concerned speak of its performance in the highest terms.

The engine we show is simple, with cylinders 20x30 ins. and 61-in. driving wheels. The calculated tractive power is about 33,400 lbs., and, with 148,000 lbs. on the drivers, the ratio of tractive power to adhesive weight becomes as 1 is to 4.4. The driving wheel base is 17 ft., and all the drivers are flanged. The third pair are the main drivers and carry the valve gear crank. This arrangement gives a long connecting rod, and it and the side rods are all of I-shaped section.

The by-pass arrangement is conveniently placed on the outside, between cylinder and valve chamber, and is

smaller end of one by-pass valve, be able to force it open, and so find relief by entering the interior of the valve and to the passage connecting both ends of the cylinder. From there it would go through the other by-pass to the exhaust side of the piston. Water, being practically incompressible, would act in the same way, and would give the required relief by traversing the same passages. We are informed by the superintendent of motive power that when first put in service the valves were exceedingly sensitive, and the by-pass gave some trouble on account of pounding, which resulted in valve breakages. This was attributed to leakage and too long a travel. The travel of the by-pass valves has now been reduced from ¾ to ¼ in., and a single packing ring has been added in the end

tom, and holds 5,000 U. S. gallons of water and carries 10 tons of coal. The tender frame is composed of 10-in. steel channels, and pressed steel trucks are used. The engine wheel base is 25 ft. 6 ins., and with the tender the whole measures 53 ft. 9¾ ins. A few of the principal dimensions are appended for reference:

Weight, in working order, engine and tender, 277,300 lbs. Axles, driving journals, main, 9 ins. x 1 1/8 ins.; others, 8½ ins. x 1 1/8 ins.; engine truck journals, diameter, 6 ins.; length, 10 ins.; tender truck journals, diameter, 5 ins.; length, 9 ins. Boiler, working pressure, 200 lbs.; fuel, bituminous coal. Fire box, type, wider length, 102½ ins.; width, 65½ ins.; thickness of crown, ¾ in.; tube, ½ in.; sides, ¾ in.; back, ¾ in.; water space, front, 4 ins.; sides, 3½ ins. and 5½ ins.; back, 3½ ins. and 4½ ins. Air pump, 9½ ins. L. H., 2-reservoirs, 16 ins. x 16 ins.; engine truck, 2 wll. swing bolster. Piston, rod diam., 3½ ins.; piston packing, C. I. rings. Valves, travel, 5½ ins.; steam lap, 1 in.; setting 3/16 in. lead F. and B. Wheels, engine truck, diam., 33 ins.; tender truck, diam., 33 ins.



# Of Personal Interest.

Mr. W. M. Duel has been appointed superintendent of the Southern, with headquarters at Birmingham, Ala.

Mr. H. M. Meason has been appointed general foreman of shops of the Pennsylvania at Philadelphia, Pa.

Mr. D. A. Leonard has accepted the position of car foreman for the Colorado & Southern at Trinidad, Col.

Mr. J. B. Cutler has been appointed general superintendent of the Gainesville & Gulf, with office at Gainesville, Fla.

Mr. A. C. Emery has been appointed purchasing agent of the Chicago Terminal Transfer, with headquarters at Chicago, Ill.

Mr. Joseph Bruce has been appointed chief inspector of fuel and locomotives on the Cincinnati, Hamilton & Dayton, at Lima, Ohio.

Mr. J. H. Barber has been appointed division engineer of the eastern division of the Canadian Pacific Railway, with office at Montreal, Que.

Mr. J. W. Oschea has been appointed enginehouse foreman of the Pennsylvania at Conemaugh, Pa., vice Mr. C. J. Halliwell, transferred.

Mr. A. Forsyth has been appointed superintendent of shops on the Chicago, Burlington & Quincy, with headquarters at Aurora, Ill.

Mr. J. W. Cookley has been appointed traveling engineer of the Cincinnati, Hamilton & Dayton, vice F. O. Miller, assigned to other duties.

Mr. Peter Harvie, superintendent of shops of the Great Northern at Havre, Mont., has been transferred to Everett, Wash., in a similar capacity.

Mr. C. H. Burk has been appointed assistant superintendent of machinery of the Mexican Central, with headquarters at Aguascalientes, Mex.

Mr. A. N. Willisie has been appointed master mechanic of the Aurora division of the Chicago, Burlington & Quincy, with headquarters at Aurora, Ill.

Mr. J. M. R. Fairburn has been appointed division engineer of the Ontario division of the Canadian Pacific railway, with office at Toronto, Ont.

Mr. D. Meadows has been appointed assistant master mechanic of the Canada division of the Michigan Central, with headquarters at St. Thomas, Ont., Can.

Mr. J. C. Jomer has been appointed assistant master mechanic of the Cincinnati, Hamilton & Dayton at Indianapolis, Ind., vice E. E. Chrysler, resigned.

Mr. D. A. Ross has been appointed road foreman of engines for the Beaumont division of the Gulf, Colorado & Santa Fe, vice Mr. J. J. Wagner, resigned.

Mr. E. A. Handy has been appointed general manager of the Lake Shore & Michigan Southern, vice Mr. W. H. Marshall, resigned. He began his railroad career as assistant engineer of construction on the Atchison, Topeka & Santa Fe, and he subsequently became engineer of bridges and buildings on the same road. Later he went to the Mexican National as locating engineer, and on that road he served as assistant en-



E. A. HANDY.

gineer and chief engineer. In 1888 he was appointed division engineer of the Lake Shore road, and in 1891 he became chief engineer and his jurisdiction was extended to cover the Lake Erie & Western Railroad, which is one of the New York Central lines. Mr. Handy has been with the Lake Shore for the past eighteen years and has gained his promotion by having passed through the subordinate positions which led up to the head of his own department of railroad work before he was advanced to the responsible position of general manager.

Mr. W. E. Boyden has been appointed purchasing agent of the Evansville & Terre Haute, succeeding Mr. M. K. Allen, who went to the Rock Island System.

Mr. K. A. Frobergh has been appointed superintendent of shops of the Great Northern, with headquarters at

Havre, Mont., vice Mr. P. Harvie, transferred.

Mr. W. S. Moore, superintendent of the Central Indiana, has been appointed superintendent of the Louisville Terminal Railway, with headquarters at Louisville, Ky.

Mr. C. A. Stark, heretofore locomotive foreman on the Canadian Pacific at Ottawa, Ont., has been appointed general foreman, with headquarters at Carleton Jct., Ont.

Mr. A. A. Scott, heretofore locomotive foreman on the Canadian Pacific at Outremont, Que., has been appointed locomotive inspector, Angus shops, Montreal, Que., Can.

Mr. A. H. Gaines, a graduate of the Burlington, Cedar Rapids & Northern Railway, has been appointed general foreman of the Denver & Rio Grande shops at Denver, Col.

Mr. W. B. Denham has been appointed general manager of the Georgia, Florida & Alabama, with headquarters at Bainbridge, Ga., vice Mr. W. M. Legg, resigned.

Mr. J. Wilkinson, heretofore night foreman on the Canadian Pacific at Outremont, Que., has been appointed locomotive foreman at Hochelaga, Que., succeeding Mr. E. Marshall.

Mr. W. L. Harrison, master mechanic on the Chicago, Rock Island & Pacific at Cedar Rapids, Ia., has been transferred to Horton, Kan., in the same position, vice G. W. Seidel, resigned.

Mr. R. H. Rutherford has been appointed master mechanic of the Chihuahua division of the Mexican Central, with headquarters at Chihuahua, Mex., vice Mr. C. H. Burk, promoted.

Mr. J. J. Cavanaugh has been appointed master mechanic of the San Luis division of the Mexican Central, with headquarters at San Luis Potosi, Mex., vice Mr. Thos. Smith, resigned.

Mr. L. B. Morehead, formerly chief draughtsman of the Toledo, St. Louis & Western, has resigned in order to accept a similar position with the Louisville & Nashville, at Louisville, Ky.

Mr. C. J. Halliwell, enginehouse foreman of the Pennsylvania at Youngwood, Pa., has been transferred to Pittsburgh, Pa., as assistant master mechanic, vice Mr. H. M. Meason, transferred.

Mr. E. Marshall, heretofore locomotive foreman on the Canadian Pacific at Hochelaga, Que., has been appointed locomotive foreman at Outremont, Que., vice Mr. A. A. Scott, transferred.

Mr. T. C. Hudson, formerly erecting shop foreman at Carlton Jct. on the Canadian Pacific, has been appointed locomotive foreman at Ottawa, Ont., on the same road, vice Mr. A. C. Stark, promoted.

Mr. John W. Thomas, Jr., has been elected president and general manager of the Nashville, Chattanooga & St. Louis, with headquarters at Nashville, Tenn., succeeding J. W. Thomas, deceased.

Mr. H. A. Ford, formerly district superintendent of the Atlantic Coast Line at Gainesville, Fla., has been appointed general superintendent of the third division, with headquarters at Jacksonville, Fla.

Mr. F. E. Fox, formerly general foreman of the C., R. I. & P. shops at Moline, Ill., has been appointed master mechanic for the same company at Cedar Rapids, Ia., vice Mr. W. L. Harrison, transferred.

Mr. F. P. Jeffries, formerly general manager of the Evansville & Terre Haute, has been appointed general purchasing agent for the Rock Island, with headquarters at Chicago, Ill., vice S. F. Forbes, resigned.

Mr. J. O. Crockett, heretofore superintendent of the Evansville & Terre Haute, has been appointed general superintendent of that road, with headquarters at Evansville, Ind., vice Mr. F. P. Jeffries, resigned.

W. E. Foster, formerly a signal inspector on the Pennsylvania lines west, has been appointed signal engineer and superintendent of construction of the Union Switch & Signal Co., with headquarters at Chicago.

H. G. Huber has been appointed assistant master mechanic of the Buffalo & Allegheny Valley at Verona, vice Mr. Taber Hamilton, promoted. The B. & A. Valley road is part of the Pennsylvania system.

Mr. A. L. Hertzberg, formerly engineer of the Ontario division, has been appointed engineer, maintenance of way, on the Canadian Pacific Railway, with headquarters at Montreal, vice Mr. F. P. Gutelius, promoted.

Mr. C. H. Andrus, heretofore general foreman of the machine shops of the Pennsylvania at West Philadelphia, Pa., has been appointed general locomotive inspector of that road, with headquarters at Altoona, Pa.

Mr. F. P. Gutelius has been appointed assistant chief engineer on the Canadian Pacific Railway, with office at Montreal. He will have immediate charge of engineering and maintenance on the company's eastern lines.

Mr. W. L. Harrison, master mechanic of the Chicago, Rock Island & Pacific

at Cedar Rapids, Ia., has been appointed master mechanic of the Kansas division, with headquarters at Horton, Kan., vice Mr. G. W. Seidel, resigned.

Mr. Frank Nowell, heretofore locomotive foreman at the Angus shops of the Canadian Pacific at Montreal, has been appointed night foreman at the Outremont roundhouse on the same road, vice Mr. J. Wilkinson, promoted.

Mr. A. W. Wheatley, formerly superintendent of shops of the Rock Island at East Moline, Ill., has resigned to become assistant superintendent of motive power of the Union Pacific system, with headquarters at Omaha, Neb.

Mr. L. W. Berry, formerly division superintendent of the Chicago, Burlington & Quincy at Beardstown, Ill., has been appointed superintendent of transportation on the Toledo, St. Louis & Western, with headquarters at Frankfort, Ind.

Mr. James Coleman, formerly superintendent of the Canada Car Company, has been appointed master car builder of the Central Vermont, with office at St. Albans, Vt. The car department was formerly in charge of the superintendent of motive power.

Mr. A. S. Wright, formerly locomotive foreman on the G. T. R. at London, Ont. and latterly in charge of water service on the Midland division of that road, has been appointed locomotive foreman on the Central Vermont Railway, with office at St. Albans, Vt.

Mr. C. C. Coffee, formerly engineer of maintenance of way of the Southern at St. Louis, Mo., has been appointed superintendent of the St. Louis division of the St. Louis-Louisville Lines, with headquarters at Princeton, Ind., succeeding Mr. A. M. Smith, resigned.

Mr. G. L. Dickover has severed his connection with the Colorado & Southern to accept the position of traveling representative of the Ralston Steel Car Co., with headquarters in Chicago. Mr. Dickover was formerly master car builder for the C. & S. at Denver, Col.

Mr. C. A. Brann has been appointed master mechanic of the St. Louis, Iron Mountain & Southern Railroad, with headquarters at Baring Cross, Ark., and will have jurisdiction from Hoxie to Texarkana, also from Little Rock to McGehee, and over the Little Rock terminals.

Mr. Frank Burns, heretofore acting master mechanic of the western division of the Frisco System with headquarters at Monett, Mo., has been appointed master mechanic of the same road. His office remains where it was, as this appointment is practically a change of title.

Mr. Edward Elden, for a number of years a master mechanic of the Lake

Shore and for some time past general locomotive inspector of the New York Central, has been appointed master mechanic of the western division, with headquarters at East Buffalo, vice William Smith, resigned.

Mr. Austin J. Collett has been appointed electrical engineer of the Union Pacific. He is now the head of a new department and has two traveling assistants, Mr. Frank J. Smith, in charge of electric lighting and shop work, and Mr. George Griswold, in charge of train lighting and electric headlights.

Mr. Letchworth Cox, who was a stoker on the first locomotive that ever got up steam in America, celebrated his ninety-first birthday at his home in Jamesburg, N. J., on Christmas Day. Mr. Cox was the son of Joseph and Hannah Cox, and was born in Chester county, Pa., in 1814. He is still in possession of all his faculties.

Mr. R. G. Long, general foreman of the Missouri Pacific Railway at Fort Scott, has been appointed master mechanic on the same road, with headquarters at McGehee, Ark. Mr. Long has been in the service of this company for a number of years, having been successively machinist, roundhouse foreman, and general foreman.

Mr. A. C. Hinckley, formerly general master mechanic of the Cincinnati, Hamilton & Dayton, has been promoted to the position of superintendent of motive power of the same road, with headquarters at Lima, O. The position of master car builder has been abolished and Mr. Hinckley will hereafter have charge of the motive power and the car departments.

Mr. R. A. Boothe has lately reached his thirtieth year of continuous railroad service. He has been a locomotive engineer for a long time and has pulled passenger out of Denison on the Houston & Texas Central for the past twenty years. During his railroad life his name has been on the pay roll every month except one, when sickness kept him at home. His thirty years of railroad work is a record of careful and honorable service.

Mr. Albert Ladd Colby has sent out cards announcing that he has opened an office as consulting and inspecting engineer and iron and steel metallurgist. Mr. Colby has had over twenty years' experience in the steel business. He has visited all the prominent works abroad and was a juror in metallurgy at the Paris Exposition in 1900. He is a thorough nickel steel expert and has written a book on steel specifications, and is a frequent contributor to the technical press and to the many scientific societies of which he is a member.

Mr. A. S. Williamson has been appointed mechanical inspector of the Mexican Central, with headquarters at Aguascalientes, Mex. He reports direct to the superintendent of machinery. On this road notices of appointments are printed in the English and Mexican languages. For the benefit of those interested we give the Mexican version and a translation of the same: "Aviso: A Quien Corresponda: Por la presente el Sr. A. S. Williamson es nombrado inspector mecánico dependiendo directamente de esta oficina. Efectivo Marzo 1° de 1906." In other words, "Mr. A. S. Williamson is hereby appointed mechanical inspector, reporting direct to this office, effective March 1st, 1906."

Mr. George Poell, a fireman on the St. Joseph & Grand Island Railway, has been the first man to receive from President Roosevelt the medal of honor for life saving by an act of heroism, in railroad service. An act of Congress approved in February, 1905, provides for the bestowal of medals of honor upon persons who, by extreme daring, endanger their own lives in saving or endeavoring to save lives from any wreck, disaster or grave accident, or in preventing, or endeavoring to prevent, such wreck or grave accident upon any railroad within the United States, engaged in interstate commerce.

The circumstances of the case are briefly that as the locomotive which Poell was firing last June was rounding a curve the engineer observed a little child in the center of the track ahead. He immediately applied the brakes and did all in his power to stop the train, which was running at about 30 miles an hour. The fireman was attending to his duties and only became aware of the child's danger on looking ahead to discover the cause of the engineer's action. Without the loss of a moment Poell dashed out of the cab window, along the running board and down on to the pilot step, hoping to be in time to catch the child and throw it clear of the train. So close was the engine upon the child that Poell was not able to secure a steady foothold. Grasping the pilot brace, he seized the child just as it would have been struck down and killed. With an effort he swung it clear, but in so doing lost his balance and fell outside the rail, but so close to the engine that his left foot was caught under the pilot, and he was dragged along and over a bridge. His foot was crushed and torn off, and he was left bleeding beside the track while the train continued to run about 300 feet further. The child was practically uninjured, but the brave rescuer will be a cripple for life. There was a young life saved by strong play when the game was hard, and the approving shout goes up from all over the field, Bravo, St.

Joe & Grand Island; and, Well done, Poell!

#### Obituary.

Robert Miller, who was for a number of years superintendent of motive power and equipment of the Michigan Central Railroad, died recently at his home in Detroit, at the age of 66 years. Mr. Miller began his connection with that road as master car builder in June, 1876. He was, in addition to the duties of M. C. B., given charge of buildings and waterworks. This position he held until 1884, when he was promoted to the position of assistant general superintendent. In September of 1890 he was advanced to the general superintendency of the road, and in 1896 he became superintendent of motive power and equipment. He retired early in 1900.

The many friends of the late L. J. Seargeant, who was for many years general manager of the Grand Trunk Railway of Canada, will regret to hear of his death at London, England, last month. Mr. Seargeant was in his eightieth year and held a unique record among railroad men. He came to Canada in 1874 from the Great Western Railway of England. He was the first traffic manager in America, and other roads followed the example of the Grand Trunk in establishing the new and important position. Mr. Seargeant was promoted to the position of vice-president in 1890, meanwhile acting as general manager. He retired in 1896, but continued on the board of directors till his death. In every respect Mr. Seargeant was a most delightful man. He belonged to the old school of English gentlemen. He was succeeded as general manager of the Grand Trunk system by Sir Joseph Hickson.

The Westinghouse Electric & Mfg. Company are finding an extensive field for their motor equipments in the marble finishing industry. They lately completed the equipment of a large marble yard in the South. The operation of this plant by means of electric drive has been eminently satisfactory, resulting in a marked increase in the product and a decrease in the operating cost. The electrification of the plant has further eliminated the many objectionable features of belting and shafting, which were very much in evidence under the old conditions.

The healthiest trade in the world is that of dye making from coal tar. Tar and the smell of it are the best of all tonics and tissue builders. The average life of a tar worker is eighty-six years. The mortality is 80 per cent. lower than in any other factory trade.

#### Electricity on Steam Railroads.

At a recent meeting of the New York Railroad Club, Mr. W. J. Wilgus, one of the vice-presidents of the New York Central, made some interesting and instructive remarks. The subject for discussion before the club was a paper read by Mr. B. G. Lamme, chief engineer of the Westinghouse Electric & Manufacturing Co., of Pittsburgh. Mr. Wilgus spoke substantially as follows:

The motives which should guide steam railroad men in advocating a change of motive power from steam to electricity in the majority of instances are based upon one or both of the following conditions: The desire or necessity to abate smoke nuisances in tunnels or terminals in large cities; or the improvement of passenger service to attract an increased patronage by the public. In other words, steam railroad companies at the present stage of the development of electricity as a motive power, do not consider its use from motives of economy, but from those of necessity or from the broader policy of improving public service. Whichever electric system is adopted, be it alternating or direct current, full consideration must be given to the question of safety to the employees of the company and to the public.

Concerning decreased danger from collision there is little to be said here, but on the question of increased danger from the use of working conductors charged with electricity we have before us at once the choice between the third rail working conductor with direct current, and the overhead construction with alternating current. It may be said that both forms have their disadvantages, but, properly installed, neither may be said to offer any more cause for apprehension on the part of railroad men or the public, than elements of danger that exist with ordinary steam railroad equipment, as, for instance, boilers carrying heavy pressures and fires in steam locomotives.

I would not like to be considered as condemning either, for there will always be local conditions that will require the use of either or both. I think, however, that it is only fair that the advantages and disadvantages of both should be made plain to those who are contemplating the future change from steam to electricity. Properly designed and protected, the third rail may be said to have the following disadvantages: Impedance with ordinary maintenance of track, and danger from derailments. Other objections have been made, as, for instance, troubles with snow and sleet, complications with frogs and switches, difficulties of current collection, and great danger to employees and trespassers. Extended experiments made

under my direction, have proved the fallacy of these objections, provided the rail is properly designed and protected. Objection has also been made to the use of the third rail because of interference with the clearance lines of equipment; but inasmuch as several trunk line railroads have already adopted the third rail so as to fix the standard outlines of equipment, other railroads must naturally adjust the outlines of their equipment to the clearance diagram that has already been adopted in order that traffic may be interchanged.

Overhead construction has the following disadvantages: Inelasticity of construction which prevents the laying of additional tracks or changes of grade and alignment without requiring radical expensive alterations in the permanent overhead structures. Danger to trainmen on the tops of freight cars. Danger to the public at overhead street and highway bridges. Danger to trains in tunnels and at other places with restricted clearances, owing to the possibility of rearing cars in cases of collision or derailment making contact with the highly charged conductor. Danger from derailments knocking down a supporting structure which would affect not only the track upon which the derailment occurs, but also all tracks on, for instance, a four track railroad, with the possibility of accident to more than one train. Danger to trains where the overhead conductor carrying, for instance, 11,000 volts, is within two or three feet of moving cars. Corrosion due to freight locomotive gases.

On the question of safety it may therefore be concluded that properly designed working conductors, either third rail or overhead, offer as much safety as is now enjoyed with present steam railroad equipment; that both types of working conductors are necessary for the full development of the art, and that as between direct current systems with third rail and alternating current systems with overhead construction, a selection of either may be made to properly fit local conditions, with the preference from a non-electrical standpoint in favor of third rail.

One of the arguments urged by the steam railroad men against the adoption of electricity for heavy railway service is the superior reliability, from the fact that the breaking down of one unit, i. e., a locomotive, still leaves unaffected other units on the system; whereas with electricity the failure of the power station or line brings all units to a standstill. To meet this argument it seems imperative that those charged with the responsibility of changing motive power from steam to electricity must reduce to a minimum the chances for a wholesale interruption

of traffic. This object can be attained as follows:

Power stations may be constructed in duplicate, so that in case of the failure of one, the other, utilizing its overload capacity and spare units, will permit the entire system to be operated, although possibly with some reduction of efficiency. The New York Central has adopted the two power station idea, either one of which, under the above conditions, can operate its system with full efficiency.

The transmission line should, where possible, be in duplicate, and the working conductor should be such, in fact as well as in name, and not utilized for transmission purposes. In other words, the working conductor should be sectionalized so that in case of breaks of any kind the trouble will be confined to the section in question, leaving the remainder of the road to be operated without delay to trains.

In order to guard against interruption of service, batteries have been considered a necessity on trunk line railroads. This has been urged not only by the advocates of direct current, but by some of those most prominent in the alternating current field. Conservative railroading on trunk lines, carrying frequent passenger, mail and express trains, should leave no stone unturned to guard against interruption of traffic, and thus meet one of the strongest arguments that has been raised by those believing that steam railroad practice with independent units is far superior to electric traction.

To secure increased earning capacity in making a change from steam to electricity, a change must also be made in the operating conditions that by long experience are known to bring about the creation of a new and remunerative traffic. The change from horse cars to electric cars improved conditions, entirely apart from the cost of operation, and created enormous increase of traffic that made the advantages from the use of electricity self-evident.

The causes of these benefits alike to the public and to the railroads were: increased speed, which was obviously attractive to the public and which increased the capacity of the railroads; more frequent stops without corresponding loss of speed, because of quicker acceleration; more frequent units.

When a steam railroad finds it desirable to change its motive power on its through trains which must be handled by locomotives, should it not at the same time follow in the footsteps of urban railroads and adopt the same flexible system of train units for its suburban traffic? By so doing trains made up of a desired number of cars

may be run with the frequency best suited to the volume of traffic at different times of the day without in any manner affecting acceleration, which in turn is largely the measure of the capacity of the road.

With multiple unit operation the power of the train is always proportioned to the load, and there is therefore a uniform acceleration; whereas with locomotive operation the larger the number of cars the slower the locomotive is in starting. Moreover, in congested terminals the use of multiple unit self-moving cars dispenses with switching, flying movements and duplicate interferences across the throat of the yard. Therefore the more frequent trains possible with multiple unit operation, quicker acceleration and higher uniform speeds, all combine to make attractive to the public the territory along the railroad adopting that system; whereas a mere change from steam to electric locomotive practice, whether of the alternating current or direct current system, brings to the railroad none of the increased earning capacity which it should secure when incurring this large expense.

#### Inventor of the Link Motion.

We have a letter from Mr. Clement E. Stretton, Saxe Coburg House, Leicester, England, the well known engineer and author, commenting on the article on "Development of Valves and Valve Motion" in our March issue, in which he says:

On p. 111 you print about the year 1843 and so on about Williams in 1843. But I have actual proof that North Midland engine 70 was in use at Derby with Howe's link motion on the 10th of September, 1842. As a fact, when Howe invented the link motion he was not at Newcastle. He was at the Vulcan foundry, Warrington, looking after the building of some engines by sub-contract. Howe completed his link and showed it to Tayleur and G. Stephenson; they said he was Robert Stephenson & Co.'s man, and he better go at once and show it to R. Stephenson & Co. at Newcastle.

After all, the invention of the link was a small matter. Look at Stephenson's fork motion, as in 1841, or look at Fig. 10, p. 110.

Look at Crampton's gear, p. 111. There are the two ends of the link. All Howe did was to pinch the link together.

That is all the invention. R. Stephenson gave Howe £20, and the link was not thought of sufficient value for a patent to be obtained.

Yours faithfully,

CLEMENT E. STRETTON.

If you want to succeed in the world you must make your own opportunities.



### Compound 4-4-2 Wind Splitter.

The state railways of the Grand Duchy of Baden have some compound 4-4-2 fast express engines of the type shown in our illustration. The engine has a conical smoke box front, and the front of the cab is pointed like the prow of a ship. Whether these designs enable the engine to cut through air any faster than it would do without them is a matter of doubt, but the conical smoke box front arrangement probably causes a sufficient uprush of air over the stack to prevent the engine trailing smoke when drifting at high speed.

The engine is a 4-cylinder balanced compound, so arranged that all the pistons drive on the main axle and leading wheels. The low pressure cylinder

tion for convenience in writing and speaking.

The weight on the drivers is given as 70,326 lbs., the total in working order being 163,140 lbs., and the tractive effort at 50 per cent. is 12,787 lbs. The whole machine is more compact and graceful in appearance to our eyes than many of the old world types are. The main valves are of the piston type, and the internal lubrication of valves and pistons is by direct forced feed, the small pump which does the work being visible above the running board, close to the lagging band which runs down from the smoke stack. The pump is actuated by a small rod and lever connected to the Walschaert valve gear which is used. The small horizontal cylinder near this oil pump, and almost in line with the reach rod, is a steam cylinder which

tape record at the end of run. For general purposes, however, the record appears to be satisfactory.

Referring to the Marienfelde-Zossen speed trials of electrically driven trains, made near Berlin some years ago, the builders of the Baden engine state that it has proved superior in traction and speed, and has accomplished some of the fastest runs ever made in Europe.

### Air Brake for Pittsburgh Railway.

A recent order for air brake equipment well illustrates the new developments in this class of apparatus. The Pittsburgh Railway Company will install 20 emergency straight air brake equipments for motor cars with CP 21 air compressors, and 10 emergency straight air brake equipments for trial cars furnished by the General Electric Com-

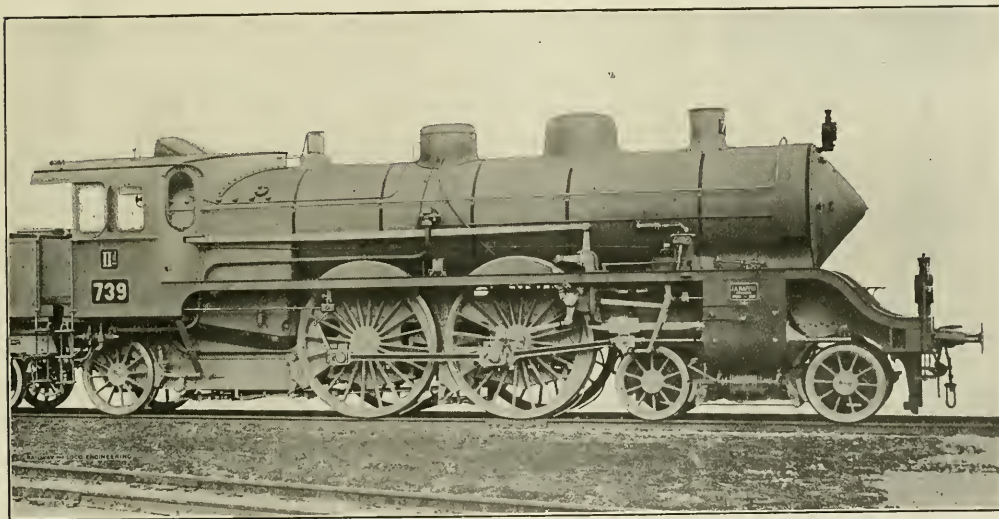

Baden State Railways, Owners.

GERMAN EXPRESS PASSENGER 442 ENGINE.

J. A. Maffei, Builder, Munich.

ders, which are on the outside, are 22.44 ins. diameter by 24.04 ins. stroke. The high pressure cylinders are 13.18 ins., with same stroke as the others. The boiler pressure is about 235 lbs., and the driving wheels are 82.67 ins. in diameter. The boiler is about 63 ins. average diameter, and the total heating surface is about 2,261 sq. ft.

This engine, which was built at the works of J. A. Maffei, of Munich, is spoken of as a 2/5 coupled express locomotive. This refers to the wheel arrangement, just as our expression 4-4-2 does. The continental system, however, represents one side, while we include both. In the foreign expression the figure 5 gives the total number of wheels on a side, and the figure 2 denotes the number of drivers on a side. The whole is put in the form of a frac-

operates a variable nozzle mechanism inside the smoke stack. The variation in the size of the nozzle is automatic and is dependent on the pressure in the dry pipe. The small cylinder is in direct communication with the source of supply.

An arm attached to the end of the side rod on the rear driver actuates a revolution counter, and from a small box hanging from the under side of the running board, which contains a set of gear wheels, a shaft runs back to the cab, where the counter is situated. In continental practice the counter is generally arranged to count driving wheel revolutions, from which the speed in miles per hour is computed. Any slip of the drivers is, of course, recorded by the apparatus, and all useless wheel turns have to be dropped out of the calculation by the man who reads the

pany, of Schenectady, N. Y. The cars upon which these equipments will be mounted are to be run singly and in two car trains, consisting of one motor car and one trailer. The type of air brake equipment above mentioned, sometimes called "semi-automatic," is essentially a straight air brake system, having in addition an emergency valve on each car, which, in case the train breaks apart, disconnects the brake cylinder from the train line and connects it directly to the main reservoir, thus applying the brakes on all cars, just as in the automatic system. In ordinary service the operation is exactly the same as with a standard straight air brake system. This method, therefore, combines the simplicity, reliability and easy manipulation of the straight air brake system with the emergency protection of the "automatic" system.

**Tight Fire Box Patches.**

The system of putting on a fire box patch as used in the Canadian Pacific shops at Winnipeg, Man., has the advantage of making a tight joint, and one which will stay so, as long as the patch lasts. This is, of course, very important, as it is obvious that any fire box patch put in when the box is in place cannot be caulked from the water space side.

The plan adopted is to use a copper liner round the joint edge of the patch, and this liner, which is one continuous band, is bent round the corners with ends joined. For small patches, less than 12 ins. across, the liners are cut out of

further flattens out and beds itself home. The bending of the liner round the corner is an interesting feature. As shown in our sketch, the liner is cut at each corner through and through, all but the folded  $\frac{1}{8}$  in. at the edge. Using this folded edge as a hinge, the whole liner is bent flat through 90 degrees, and a washer something like a fan is put in to fill the space and hold the corner patch bolt. This plan of bending the liner secures the broad, flat  $1\frac{3}{8}$ -in. band all round and gives an unbroken strip of folded copper  $\frac{1}{8}$  in. all the way round, also just like the wire joint of a steam chest.

The first operation when applying

The patch is heated and held in place by several bolts passed through the holes for the stays, when it is carefully fitted and the remaining holes are drilled and tapped. When this is done the holes in the patch are reamed  $\frac{1}{8}$  in. larger than the diameter of the patch bolts, and they are countersunk to suit. When everything is ready the copper joint is inserted and the whole tightened up for keeps. Mr. S. J. Hungerford, the superintendent of the company's locomotive works at Winnipeg, speaks with much satisfaction of this method of applying fire box patches, and the results obtained in practice are said to be very satisfactory. Mr. Hungerford's shops take care of engines running in the bad water district, where boiler work almost rises to the dignity of a specialty.

**Large Roofing Order.**

In rebuilding the factories of the Ohio Brass Company, Mansfield, Ohio, which were partially destroyed by fire last year, the order for roofing was placed with the H. W. Johns-Manville Company through their Cleveland branch. The roofing to be employed is the well-known "J-M Asbestos Roofing," which is coming into very general use for large manufacturing establishments, railroad stations and other large buildings. The successful firm are to be complimented that the brass company's plant is one of on securing this order for the reason the most prominent in the State of Ohio, and the competition between bidders was very keen. The order, which amounted to 850 squares, was placed with the H. W. Johns-Manville Company, of New York, after a thorough investigation of the merits of their product.

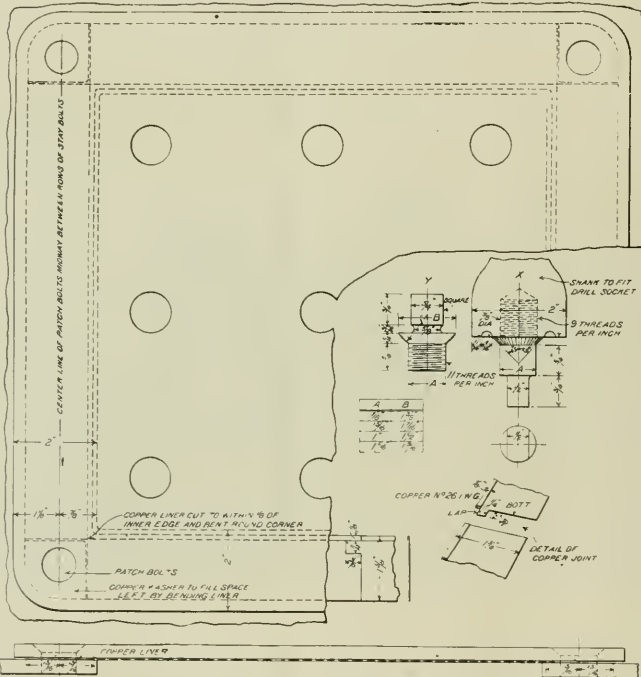

METHOD OF APPLYING PATCH TO LOCOMOTIVE FIRE BOX.

a copper sheet. The detail of the joining of the strip simply consists of a butt joint of the copper with a lap  $\frac{1}{4}$  in. wide and  $\frac{3}{8}$  in. deep, close to the water edge on one end, which beds right down into the other end when everything is in place, and it forms a sort of tie between the two.

The copper strip or liner is made about  $1\frac{3}{8}$  ins. wide, and a narrow strip on the edge,  $\frac{1}{8}$  in. wide, is folded back and flattened down very like the way so-called tin plate is handled when the edge of a box lid is folded over and flattened down to prevent it cutting the hands. This  $\frac{1}{8}$ -in. folded and flattened edge in the fire box copper liner is at the water space side, and when the patch is finally in place this fold still

this kind of patch is to arrange it so that all the defective parts of the sheet will be removed and so that the joint holes will be central between the stay-bolts. The plate is cut out so as to leave  $\frac{7}{8}$  in. from the center of the joint holes for an inside lap. The patch itself is then prepared by marking the size of the opening cut in the plate, and the joint holes are then punched all round at a distance of  $\frac{7}{8}$  in. from the cutting mark and allowing  $1\frac{1}{8}$  in. for outside lap when shearing. The holes are drilled to suit the tap and patch bolts and are from  $1\frac{3}{4}$  to  $1\frac{7}{8}$  in. pitch. The copper liner does not fully come out to the fire edge of the patch, and when the edge is caulked the patch and sheet touch each other.

Some very useful hints on the subject of foundations and setting of machine tools may be had by a perusal of a neat little booklet issued by the engineering bureau of the Niles-Bement-Pond Company. There are general notes, notes on concrete, brick, excavations, foundation, bolts and washers, bearings, bearing values, sand, stone, mixing, laying, freezing, and the setting of machines. Under the head of Bearing Values a table is given of what different kinds of material will support per square foot. The table includes ledge rock, which will carry 36 tons to the square foot; hardpan, 8; gravel, 5; clean sand, 4; dry clay, 3; wet clay, 2, and loam 1 ton per square foot of superficial area. These figures the writer of the pamphlet has taken from a paper read in 1903 before the Boston Society of Civil Engineers. Those interested should apply to the company for a copy of the booklet. Their head office is in New York.

# Old-Timer Talks No. 2



Some of the boys, when they open the cylinders, think everything is O. K. if the inside of the cylinder is bright like

silver. But suppose they only found bright streaks, then they'd think friction did it, of course.

Now, for a fact, a bright surface shows a "friction polish;" an "oil polish" is somewhat dark. Rub a surface with a polishing rag and see how bright it gets—friction does it.

The very best polish I know is the "graphite glaze." Graphite, if the flake is pure and thin—DIXON'S kind, you know—fills in the grain of the metal and makes it smooth as glass.



You ought to send to the Dixon people for free sample No. 69-C. It's "great stuff."

Joseph Dixon Crucible Co.  
Jersey City, N. J.

## Government Ownership in Japan.

The tendency toward what has been called autocratic socialism has recently been shown by Japan in the passage of a bill by her House of Representatives authorizing government ownership of all the railways in the island. Some time ago the Japanese government took over the tobacco business, and now it is the railways.

The first railway in the Flowery Kingdom was built in 1872 and was owned and operated by the government, as at that time there was not much private capital to be had for such undertakings. About eight years later, however, the building of railways by incorporated companies began, and now the figures stand 1,226 miles of government roads and 3,027 miles privately owned. The capitalization of these roads has been at about \$35,000 per mile.

The amount which the government will pay for the railways amounts in round numbers to about \$250,000,000, which is about twice the total amount of the capital invested, and the experiment with state owned railroads will be fully and carefully made. In view of the thorough way in which the Japanese go about the accomplishment of any purpose which they desire to bring to a successful issue, we may expect to see a very satisfactory performance from both a financial and an operating standpoint.

A neat little pamphlet has been issued by the C. W. Hunt Company, of New Brighton, describing cable railways, automatic railways, hoisting engines, electric and steam conveyors, overhead trolleys, scales, industrial railways, and, in fact, all sorts of appliances for economically and quickly handling material and doing work. This concern designs and builds all kinds of coal handling machinery, and the pamphlet gives one a good idea of the extent and variety of all the devices which may be had. The catalogue practically acquaints the reader with the state of the art, as patent lawyers say, and it is up to date in every particular. Write direct to the company if you would like a copy. Their New York address is 45 Broadway

## Cutter for Continuous Length Packing.

Every practical engineer to whom time is an object, will appreciate the convenience and utility of a simple but ingenious device recently placed on the market. With the Exacto Packing Gauge and Cutter, as it is called, and the engineer knowing the diameter of the rod he has to pack, may use what are called continuous length packings and they will be found to be quite as convenient to handle as ring packing is.

One of our illustrations shows the device ready for use. The dial is set at the figure representing the diameter of the rod to be packed, plus the diameter of the packing to be cut, while a set screw secures the stop in place. The free end of the packing is first cut to the proper bevel in the gauge and is then passed into the apparatus until the beveled end fits tightly into the stop.

With the thumb of the left hand the engineer presses down the knife guide, at the same time firmly holding the packing in place. The knife of the serrated edge variety, something like a Christy bread knife, is then inserted in

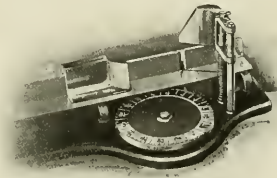

PACKING GAUGE AND CUTTER.

the guide and the cut is made, as will be seen in our second illustration. The result is that a ring with the ends cut to the required bevel is now ready for use and will exactly fit the rod. All the rings cut to this measure will be exactly of the same size; there is no waste due to errors in cutting, no loss of time in fitting the packing to the rod, and if the packing is as it should be, a tight joint and a workmanlike job is assured.

We have been favorably impressed with this little instrument and suggest that those interested should write to the makers, Messrs. Greene, Tweed & Com-



USING THE PACKING CUTTER.

pany, who are also the makers of the Palmetto air pump packing, and ask for the little descriptive catalogue which they have issued. Their address now is 109 Duane street, New York.

## The Money-Making Steer.

There is a saying in the Chicago Stock Yards that everything about a packed hog is turned into money except the dying squeak. The domestic steer is not far behind the hog in having every ounce converted into currency. The bones of animals of the cow kind have considerable value and other refuse

parts are nearly as valuable as the by-products of gas coal. The four feet of an ordinary ox will make a pint of neat's foot oil. The thigh bone is the most valuable, being useful for cutting into toothbrush handles. The foreleg bones are made into collar buttons and parasol handles. The water in which the bones are boiled is reduced to glue, while the dust which comes from sawing the bones is turned into food for cattle and poultry.

#### Locomotive Sander.

This locomotive sander is said by the makers, Knight & Heath, of Huntington, Ind., to be simple, durable and reliable; also that it can be operated with 5 lbs. pressure or less. It is worked partly by pressure and partly by suction, throwing and drawing anything through the discharge pipe that will pass between the nozzle and outer bushing of the sander.

The nozzle is so arranged that it can be moved away or toward the sand in the vertical fitting with a head that is gauged to the outer bushing, thus regulating the flow of sand and creating a suction in the vertical fitting with the nozzle at the head of the body of sand,

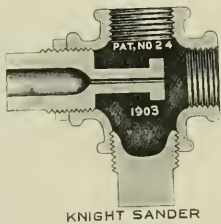

so that the sand follows the air and is carried directly under the wheels.

One pair, used for demonstrating, has been in continual service for three years and they have not taken five minutes' time for repairs, and when removed for inspection it was found that all the bearings were still true to gauge and not a particle of wear could be detected in any part of the sander.

The Safety Car Heating and Lighting Company's two latest catalogues have just come to hand. One is devoted to the Pintsch light with which travelers generally are familiar, and the other deals with incandescent mantle lamps for Pintsch gas, which is the newer system this company has brought out. Both these publications are useful to railroad men, and they would be most instructive to any intelligent reader, especially the one concerned with the incandescent light. By this new method the Pintsch gas burner is inverted and the candle power of the flame is much increased and a steady white light is produced. The globe to which the holder is at-

tached carries the mantle and is supported by a thread on the burner nozzle. By turning the globe and the globe ring, the mantle, holder and globe can be removed leaving the burner free and projecting downward. The parts are illustrated by beautifully clear drawings, numbered and named so that the explanation can be readily followed and parts ordered without confusion. The general appearance is shown in a number of excellent half-tones, and, in short, the catalogues are all and more than such publications usually are. If you have anything to do with Pintsch lighting, these catalogues cannot fail to be useful to you and if you do not know much about the subject they will be worth getting hold of, for the information they contain. Pintsch gas gives light in railway cars, and the Pintsch catalogues give light on the subject to railway men. Our advice is to write direct to the company's New York office, 160 Broadway, and ask for one or both.

#### Swung His Lantern.

Representative John Sharp Williams tells a tale of the days when he was counsel for a railway line.

At one point on its line the company had stationed an old negro watchman whose duties consisted in warning travelers when a train approached. One night a wagon belonging to a farmer was struck, resulting in a bad accident. The company was sued for damages, and the old darkey was the principal witness for his employers. Among the questions was one as to whether he was sure that he had swung his lantern across the road when he perceived the train approaching. The negro replied:

"I shorely did, sah!"

The trial resulted in a verdict for the company, and Mr. Williams, as counsel, took early occasion to compliment the aged negro on his excellent testimony, to which the latter replied:

"Thankee, Marse John, but I was sorely skeered when dat lawyer man begin to ask me about de lantern. I was afeared for a minute dat he was goin' to ask me if it was lit or not. De oil done give out some time befo' de accident!" —Success.

The Chicago Pneumatic Tool Company have closed their Norfolk office and will in the near future open an office in Richmond, Va. Their office in the Empire building, Pittsburgh, Pa., will be moved on April 1 to 10 and 12 Wood street, at which point a store has been secured for the purpose of making a general display of air compressors, tools, etc., and a repair department will also be maintained at that point. Their office at Seattle, Wash., has been closed, and a new office has been opened at No. 84 Sixth street, N., Portland, Ore.

## The Best and Cheapest Books for Railroad Men

**AIR BRAKE CATECHISM** <sup>Price,</sup> **\$2<sup>00</sup>**

By Robert H. Blackall. 20th Edition. Contains 1500 Questions and their Answers on the Westinghouse Air Brake, which are strictly up-to-date. Includes two large Westinghouse Air Brake Educational Charts printed in color. Gives the necessary information to enable a railroad man to pass a thoroughly satisfactory examination on the subject of Air Brakes. The author's many years' experience as Air Brake Inspector and Instructor enables him to know at once how to treat the subject in a plain, practical manner. Endorsed and used by Air Brake Instructors and Examiners on nearly every railroad in the United States. The standard and only complete work on the subject. 312 pages.

**LOCOMOTIVE BREAKDOWNS AND THEIR REMEDIES** <sup>Price,</sup> **\$1<sup>50</sup>**

By Geo. L. Fowler. Just issued. Tells how and what to do in case of an accident or breakdown on the road; includes special chapters on Comp and Locomotives. Better procure a copy, as it contains 800 Questions and their Answers on Accidents and Breakdowns.

**LOCOMOTIVE CATECHISM** <sup>Price,</sup> **\$2<sup>00</sup>**

By Robert Grimshaw. 23rd Edition. Right up-to-date and contains 231 large Folding Plates and 1600 Questions and Answers on How to Run a Locomotive. The Standard Book on the subject, being written in plain language and free from mathematical formulae and complex problems.

**NEW YORK AIR BRAKE CATECHISM** <sup>Price,</sup> **\$1<sup>00</sup>**

By Robert H. Blackall. The only complete treatise on the New York Air Brake and Air Signaling Apparatus, giving a detailed description of all the parts, their operation, troubles, and the methods of locating and remedying the same. 250 pages.

**COMBUSTION OF COAL AND THE PREVENTION OF SMOKE** <sup>Price,</sup> **\$1<sup>50</sup>**

By Wm. M. Barr. Contains over 800 Questions and their Answers on the Science of Steam Making.

**AIR BRAKE CHARTS** <sup>Price,</sup> **50<sup>c</sup>**

Showing the Westinghouse Equipment in ten colors, including freight and passenger engine. Every railroad man should possess these charts at this low price.

A Special request. Any of these books Circular sent pre-paid on receipt of price.

Agents Wanted at Every Terminal. Write for our special terms. You can make equal to a month's pay selling our books on the side

**The Norman W. Henley Pub. Co.**

132 Nassau Street, New York, U. S. A.



# Pipe Covering FOR SHOPS

Our line of Covering is the largest and includes a covering for every condition and requirement. The following grades are specially recommended for railroad shops, on account of their high efficiency and great durability:

**HIGH PRESSURE STEAM**  
Asbestos Sponge Felt Covering

"J-M" 85 per cent. Magnesia Covering  
Asbestos Fire Felt Covering

**FOR MEDIUM PRESSURE STEAM**

Asbestocel Covering  
"J-M" Asbestos Moulded Covering  
"J-M" Air Cell Covering

**FOR LOW PRESSURE STEAM AND HEATING SYSTEMS**

Asbestocel Covering  
Champion Covering  
Aqua Covering  
Asbestos Fire Felt Train Pipe Covering  
Locomotive Lagging  
Pump Packings

WRITE NEAREST BRANCH FOR CATALOGUES

**H. W. JOHNS-MANVILLE CO.**

Manufacturers of ASBESTOS and MAGNESIA PRODUCTS, ELECTRICAL INSULATING MATERIALS, "NOARK" FUSE DEVICES, ELECTRICAL RAILWAY SUPPLIES, ETC.

NEW YORK	ST. LOUIS	KANSAS CITY
MILWAUKEE	PITTSBURG	MINNEAPOLIS
CHICAGO	CLEVELAND	LITTLE ROCK
BOSTON	SAN FRANCISCO	NEW ORLEANS
PHILADELPHIA	LOS ANGELES	LONDON
	SEATTLE	



60

## You Can Search Me.

BY A. O. BROOKSIDE.

The way a superintendent of motive power may be suddenly called upon to show the metal he is made of is well exemplified by the following story which came under the writer's notice, properly vouched for, not long ago, and the way that it happened was this:

The S. M. P. of a large road was called to the telephone one beautiful autumnal afternoon, and he lightheartedly reached for the bugle and blithely said "Hello." Now, at the other end of the wire was a High Official, on the still hunt for "information." After a few hurried words intended for identification, not for greeting, the H. O. asked for the price, which he, the S. M. P., could build in his, or, rather the company's, shops a bunch of seventeen engines composed of three or four each of five different classes of locomotives, cylinders, wheels and weights given.

The S. M. P., though metaphorically chained to the instrument, deftly drew a blue envelope from his pocket with his one disengaged hand and jotted down a rough approximate price for one of each class. He had not built any engines of the classes specified for over a year, and the price of material had advanced. Albeit, with the aid of his good brains, his disengaged hand and the blue envelope, he managed to figure out what he thought was a fair price, fully expecting to be given time to consult records and go over his figures with all diligence and to be permitted to embody the same in a formal letter, if, perchance, the High Official meant "business." Instead of this he was given a short shrift and a long rope, as will be seen, if you continue to read this narrative, and a "thank you very much" closed the interview.

Next morning among his railroad letters was one from the H. O. which began in the time honored way: "Confirming our conversation of yesterday," etc., etc., and went on: "You will at once proceed to build," etc., etc., "all and singly the locomotives mentioned, to wit," etc., etc., "at the prices quoted by yourself," etc., etc., and "yours truly." The S. M. P. gasped for more oxygen, but set to work and turned out the required engines in the specified time. When the cost of each engine came to be made up by one over whom the S. M. P. had no jurisdiction nor any means of friendly communication, it was found that the S. M. P. had builded better than he knew and that he was "in" several paltry hundred dollars, and that much below the telephonic price of the machines, and behold he smiled quietly to himself and was of good courage.

Moral: Be brave and strenuous and keep in sight of the procession, and be full of knowledge, and never back out

through the small end of the telephone bugle, and you may achieve honor and renown and your salary may not be lowered for a little while thereafter.

## Campbell Drop-Bottom Gondola.

There is a design of a drop-bottom gondola recently brought out by Mr. Argyle Campbell, which is in the hands of the Enterprise Railway Equipment Co., of Chicago. The car is 100,000 lbs. capacity and the floor on each side practically consists of eight drop doors. The total inside length of the car is 41 ft. and the width is 9 ft. 5 ins., and the sides are 4 ft. 2 ins. high. The floor doors, of which there are 16, operate in sets of four and are said to discharge 95 per cent. of the load.

The center sills are made of 15 in. and the side sills are 8 in. channels. The body bolsters are of substantial design and there are five pressed steel diaphragms, as they are called, spaced at 5 ft. centers between the body bolsters. These constitute the transverse framing of the car and form the sections between which the floor doors open.

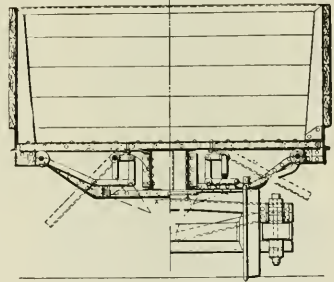

CAMPBELL DROP-BOTTOM GONDOLA.

There are 7 inside stakes on each side. They are made of 1/4 in. steel plates bent like angle irons, but they taper from the floor up and thus form a series of stiff pillars, if one may so say. They are 2 1/2 ins. at the top and 7 ins. wide at the bottom, and these stand on, and are riveted to, the diaphragms.

Each set of 4 doors is operated by a 2 in. shaft running along near the center sills and as the hinge of the doors is close to these sills, the operating shaft and mechanism can be easily got at whether the doors are shut or open. The doors are operated by a ratchet lever at the car ends. The opening and closing mechanism for each door is arranged to move by the throw of a crank, into which form the longitudinal shaft is bent where required. The doors are locked by a ratchet and sagging or gaping along their outer edges is impossible. The design is substantial and simple, and care has been taken to secure maximum carrying capacity together with ability to stand the wear and tear which such cars have to meet.

### Breaking of Glass Prevented.

The sketch which we reproduce here has been sent to us by Mr. John F. Long, one of the gang foremen of the Frisco System, in their Monet, Mo., shops. The headlight case shows that a long, narrow slot has been cut in the underside of the circular projection which holds the glass. This has been done for the purpose of helping to preserve the circular glass.

It is effective where the electric head-

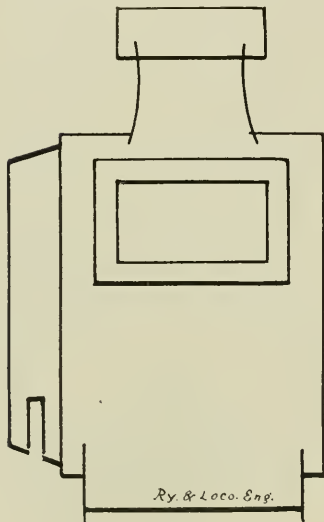

HEADLIGHT WITH AIR SLOT.

light is used, because, although the light does not require a constant supply of air in the same way that an oil light would require it for the purpose of supporting combustion, yet the arc light gives off a great deal of heat and the air inside the case gets very hot and in consequence the inside of the circular glass becomes warm while the outside may be quite cool if, indeed, not actually cold.

The current of air passing in through

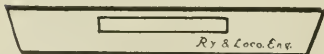

PLAN OF HEADLIGHT AIR SLOT.

the slot helps to reduce the temperature as it passes up in a broad stream near the glass. There is no danger of blowing out the arc lamp by this method of introducing air and the breakage of the circular glass is prevented. If the case is used for an oil lamp at any time it is very easy to block up the slot and the case is then practically as it was before.

The world is not overstocked with that species of humility which moves a man to make himself the best hand in his line before looking for the best pay.

The Baldwin Locomotive Works' Record of Recent Construction No. 54, is just off the press. It is like similar publications got out by this well known firm, and is very interesting and excellently illustrated. The descriptive letter press is in English and French, and among the locomotives shown, all of which were exported, we may mention a Mallet compound built for the American Railroad of Porto Rico, a consolidation for the Estrada de Ferro Central do Brazil, a passenger ten-wheeler for the Ferro Carril Andino of Argentina, a ten-wheeler for the Cuban Central, a consolidation for the United Railways of Havana, a tank engine and a consolidation for the Imperial Government Railways of Japan, a mogul for the Hokkaido Government Railroad (Japan), a six-wheel tank engine for the Ferro Carril Transandino Por Antuco (Chile), a mogul for the Maui Agricultural Co. (Hawaii), and several other foreigners. Dimensions, weights and style of service, together with other particulars, are given in each case. Write direct to the builders if you would like to see some interesting samples of American work for abroad.

The railroad companies that object to the regulating of transportation rates and the financial tyrannies that insist on the government leaving them alone, are glorying in the stand that Congress is taking against the efforts of President Roosevelt to obtain a square deal for the people at large. The joy of the robber interests will not be very long lived. The people will have the chance to cast ballots again and there is great likelihood that they will decide that the Socialists form the force to give the people justice.

### Instruction Car in the Home.

One of the marked features of railroading in the twentieth century is the multiplying presence of the instruction car. It has not only come to stay, but it has come to grow and blossom into a great educational institution. To the railroad man it is of more importance than the study of Xenophon or Sallust. Indeed, it is an open question in many of our seats of learning as to whether the time spent in learning dead languages might not be better spent in learning living truths. We will not venture an opinion on a question outside of our proper province. It may be a good thing to learn many languages if the ideas arising in the mind of the linguist are so multitudinous that one tongue cannot furnish sufficiently apt expression, just as a pump may require several nozzles to allow the flood of many waters to be relieved. The books we keep on hand are all written in the English language, and when used they form what may be called the instruc-

# GOLD Car Heating and Lighting Co.

Manufacturers of

**ELECTRIC,  
STEAM AND  
HOT WATER  
APPARATUS  
FOR RAILWAY CARS**

**EDISON  
STORAGE  
BATTERY  
FOR RAILWAY CAR  
LIGHTING**

Largest Manufacturers in the World  
of Car Heating Apparatus

Catalogues and Circulars  
cheerfully furnished

Main Office, Whitehall Bldg.  
17 BATTERY PLACE  
NEW YORK

# Homestead Valves

Straightway, Three-way and Four-way, and

# Homestead Locking Cocks

Are Famous the World Over

They cost more, but are worth very much more than other makes. You try them and see.

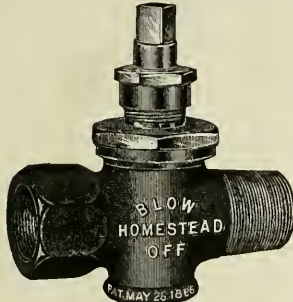

Brass, 1 1/4 in., \$6.00 net

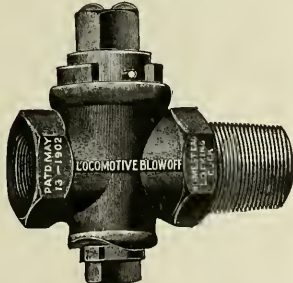

Iron Body, Brass Plug, 1 1/4 in., \$4.00 net

## Homestead Valve Mfg. Co.

WORKS, HOMESTEAD, PA. PITTSBURG, PA.

## American Locomotive Sander Company

13th & Willow Sts., Philadelphia, Pa.

Proprietors and Manufacturers

LEACH, SHERRBURNE, DEAN, HOUSTON, "SHE" and CURTIS SANDERS

### THE ROBERT W. HUNT & CO.

Bureau of Inspection, Tests and Consultation, 1137 THE ROOKERY, CHICAGO.

66 Broadway, New York. Park Building, Pittsburgh. 31 Norfolk House, London, Eng.

Inspection of Steel Rails, Splice Bars, Railroad Cars, Wheels, Axles, etc. CHEMICAL LABORATORY—Analysis of Ores, Iron, Steel, Oils, Water, etc. PHYSICAL LABORATORY—Test of Metals, Drop and Pulling Test of Couplers, Draw Bars, etc. Efficiency Tests of Boilers, Engines and Locomotives.

tion car at home. Among our books are:

"Machine Shop Arithmetic." Colvin and Cheney. This is a book that no person engaged in mechanical occupations can afford to do without. Enables any workman to figure out all the shop and machine problems which are so puzzling for want of a little knowledge. We sell it for 50 cents.

"Firing Locomotives." Sinclair. Treats in an easy way the principles of combustion. While treating on the chemistry of heat and combustion, it is easily understood by every intelligent fireman. The price is 50 cents.

"Skeevers' Object Lessons." Hill. A collection of the famous object lesson stories which appeared in this paper several years ago. They are interesting, laughable, and, best of all, they are of practical value to-day. \$1.00.

"Standard Train Rules." This is the code of train rules prepared by the American Railway Association for the operating of all trains on single or double track. Used by nearly all railroads. Study of this book would prevent many collisions. Price, 50 cents.

"Mechanical Engineers' Pocket Book." Kent. This book contains 1,100 pages, 6x3 1/4 ins. of closely printed minion type, containing mechanical engineering matter. It ought to be in the bookcase of every engineer who takes an interest in engineering questions. We use it constantly as a reference for questions sent to us to be answered. Full of tables and illustrations. Morocco leather, \$5.00.

"Locomotive, Simple, Compound and Electric." Reagan. An excellent book for people interested in any kind of locomotive. It will be found particularly useful to men handling or repairing compound locomotives. It is the real locomotive up to date. \$2.50.

"Simple Lessons in Drawing for the Shop." By O. H. Reynolds. This book was prepared for people trying to acquire the art of mechanical drawing without a teacher. The book takes the place of a teacher, and has helped many young men to move from the shop to the drawing office. 50 cents.

"Locomotive Running Repairs." By L. C. Hitchcock. This book contains directions given to machinists by the foreman of a railroad repair shop. It tells how to set valves, set up shoes and wedges, fit guides, care for piston packing, and, in fact, perform all kinds of work that need a thoughtful head and skilful hands. 50 cents.

RAILWAY AND LOCOMOTIVE ENGINEERING, is a practical journal of railway motive power and rolling stock, and it is so not only in name but in reality. By reading it you get a knowledge of what others think and do. \$2.00 a year; bound volumes, \$3.00.

### Metal Ties.

Some interesting information can be had by the perusal of the latest catalogue of the Truss Steel Tie Co., of Pittsburgh, Pa., and some striking views of track laid with metal ties are given. The tie used is of I-section rolled steel and the outer edges of the top flange are notched or indented near the ends so as to receive the rail fastening made by this company. The tie is imbedded in the ballast and each pair of ties is so placed that the end of one lies near the end of the next, in a series of flat zig-zags like the outline of a snake fence, but with this difference, that the angle which the ties make with each other is much more acute and the ends of the ties do not touch each other. For instance, the right hand ends of ties A and B are near each other and the left hand ends of ties B and C are similarly placed. The adja-

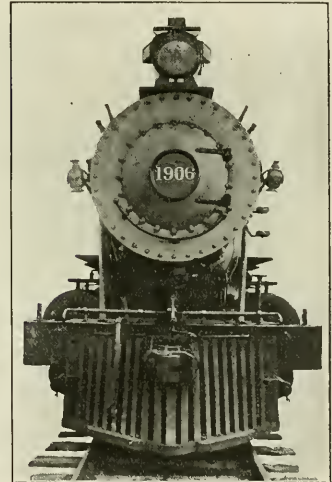

TOO CLOSE TO SEE THE SMOKESTACK.

cent ends of the ties are bound together by bolts or truss rods which pass from the rail fastening of one to that of the next. This zig-zag method of placing the ties prevents any lateral movement of the ties in the roadbed, and in conjunction with the truss rod running from tie to tie is believed to be a very effective plan for preventing alteration of gauge on tangents and particularly on curves. If you wish to get a good idea of what this kind of a roadbed looks like write to the company for a catalogue. The illustrations practically tell the whole story, but the letter press explains it more fully.

A stubborn mind conduces as little to wisdom, or even to knowledge, as a stubborn temper to happiness. A stubborn investigator labors to make facts agree with his own preconceived ideas.

We have received a copy of the paper on water softening for boiler use, presented to the Western Society of Engineers, by Mr. T. W. Snow, manager of the Otto Gas Engine Works, of Chicago. Mr. Snow has also kindly sent us a copy of a series of really beautiful photographs showing the water softening installation on the Chicago & Eastern Illinois Railroad. Among the interesting facts and figures given by Mr. Snow in his paper, an example from the experience of the Missouri Pacific will be of interest. He said that the railway last year put in three water purifying plants, to see what effect would be produced. The number of engine failures reported in the middle of last winter were 21 daily. An auxiliary engine was kept in steam at many of the stations along the line in readiness to take the place of any of those which might fail. After six months' use of the water softeners, the direct saving was estimated at \$2,000 a month. This amount formerly went in wages to boilermakers and for tubes, and the twenty odd auxiliary engines

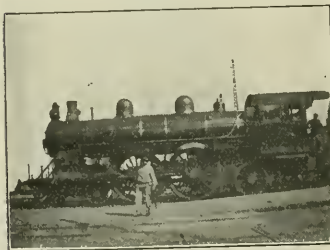

"A GENTLEMAN OF FRANCE."

which had previously been strung out along the road were all in regular service moving paying loads. The direct and indirect saving is thus seen to have been a very considerable item. Mr. Snow will be happy to send a copy of his paper to anyone interested enough to ask for one, and the photographs themselves are worth having.

**Heavy Rails.**

There are some very heavy rails used on the belt line around Philadelphia. They weigh 142 lbs. to the yard, and that is said to be 17 lbs. more to the yard than the heaviest rails heretofore made in this country; in fact, the Philadelphia road probably has the heaviest rails in the world. They are laid on ties made of 9 in. girders, and the ballast is concrete. All the curves and switches are laid with the heavy rails and it is more than likely that the track will not require any repair work for many years. The road is considered to be superior to any railroad section ever constructed. The 142 pounders were made specially for the Pennsylvania Railroad.

The H. B. Underwood Co., of Philadelphia, makers of special tools for railway repair shops, are sending with their compliments a copy of Colvin's little book on link motion, to all master mechanics and superintendents of motive power in the country. A notice of the book will be found on page 160 of this issue of RAILWAY AND LOCOMOTIVE ENGINEERING, and if you are a master mechanic or S. M. P. on any railway in Canada, the United States or Mexico, and find that you have not received a copy of this book from the Underwood Co., write to them and point out the fact and they will send you one. Their address is 1025 Hamilton street, Philadelphia, Pa.

**Power for Long Hauls.**

There was a very ingenious idea lately put forward by the general manager of a western telephone company. It is intended to do away with the slow method now in vogue for getting the cables through conduits where wires have to be put under ground. The usual way of doing this work is to have a number of rods each about 3 ft. long with screw threads and sockets on each alternate end. To the front of the first a string or wire is fastened and the rod pushed into the conduit. When that is "all in" a second length is screwed on and, like a good thing, it is pushed along, then another length is added and another and another, and so on, until the front end with the string or wire attached comes out at the far end of the conduit. The rods are then drawn out one by one and unscrewed and the string or wire thus drawn into the conduit is used to draw a cable through, and the wire comes out ready for the next conduit.

The management intends to use animal power to do the work, and for this purpose some able bodied ferrets are to be employed. They will be housed and fed by the company, but their names will not appear on the payroll. The idea is to take a ferret whose body will loosely fit the tube-like conduit and harness him up so that as he progresses along the conduit he will draw a long, light string after him into the tube. Our information does not include the reason why the ferret will perseveringly go on, but it is probable that his instinctive desire to get to the end of a long hole will stand him in good stead, and, moreover, he may be made to believe that there is a rabbit at the other end. He cannot well back out and if he falls by the way, so to speak, he can be prodded out by the use of the sectional rods aforesaid. When the ferret emerges with the string he will be asked to try another, while the string he carried will be used to draw a copper wire through, that in turn will be attached to a rope, and, finally, the cable will be placed.

**Locomotive Blow-Off Plug Valves**

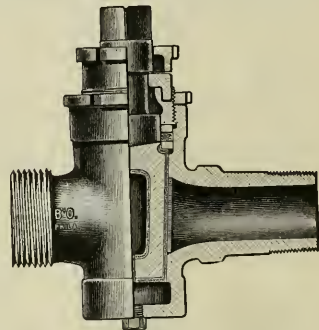

Fig. 9.

All Brass, extra heavy, with Cased Plug. For 250 lbs. pressure. Made with Draining Plug to prevent freezing.

**Locomotive Gauge Cocks**

For High Pressure

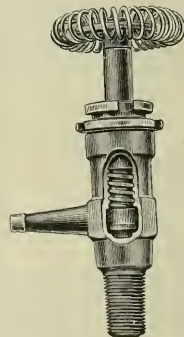

Fig 23, with Wheel.

Bordo Self-Grinding Gauge Cocks, made with renewable Hard Bronze Disc. Opened and closed with a quarter turn. Guaranteed Steam tight under the most exacting conditions. Shanks Threaded to specifications for Locomotives.

**Swing-Joints and Pipe Attachment**



Fig 33.

May be applied between Locomotive and Tender. These Swing-Joints are suitable for Steam, Gas, Air, Water or Oil.

Complete Booklet on Application  
**L. J. BORDO CO.**  
PHILADELPHIA, PA.



## ENGINEERS AND FIREMEN, YOU CAN BE HELPED

in passing your examination  
for promotion or in keeping  
up-to-date.

### Spangenberg's Steam and Electrical Engineering

Price, \$3.50

Money refunded if book not  
satisfactory.

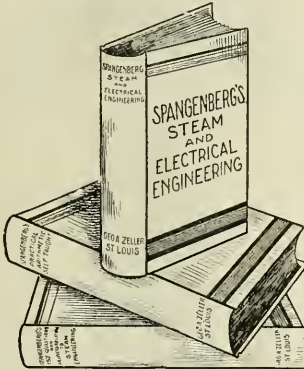

Steam and Electricity are divid-  
ing the railroad field. This book  
covers both subjects. Contains  
1035 questions and answers.

CUT OUT AND MAIL TO-DAY  
**GEO. A. ZELLER BOOK CO.**  
19 S. 4th Street, ST. LOUIS, MO.

I accept your offer to send me, express pre-  
paid, one of Spangenberg's Steam and Elec-  
trical Engineering, price, \$3.50, and enclose  
\$2 as first payment. The balance, \$1.50, I  
agree to remit within 30 days.

Name.....  
Street or Box No.....  
City and State.....

# Patents.

GEO. P. WHITTLESEY

MCGILL BUILDING WASHINGTON, D. C.

Terms Reasonable. Pamphlet Sent

# Molding Machines

Vertical Vibration. Power Draft

ALL KINDS OF MACHINES

THE E. H. MUMFORD CO.

17th & Callowhill Streets, PHILADELPHIA, PA.

J. W. JACKMAN & CO., Ltd., 29 Victoria St., London, S. W.

It is said that a well disposed ferret can do the work of four men at cable laying. If it should be possible to get a rabbit to hop through the conduit ahead of the ferret there is no knowing how many men he might be able to put out of business. Under the Interstate Commerce law the ferret will be compelled to charge more for a long haul than for a short one, and not give any rebates.

### Mud Ring Drill.

Our illustration shows a new mud ring drill which the Bickford Drill & Tool Company, of Cincinnati, Ohio, have just placed on the market. A very satisfactory point about the machine is that

of change gears which are held in position by spring plungers, thus enabling the operator to change quickly from one speed or feed to another without lessening the available power of the machine. A dial on the large worm wheel at the right shows where to set the dog to trip the feed at any desired depth.

The spindles are 1 1/8 ins. in diameter, and have a vertical movement of 12 ins. They work to a maximum center distance of 26 3/4 ins. The table has a transverse movement of 24 ins., and receives, between housings, with a 12 ft. rail, 10 ft. 6 ins. Driven by a constant speed pulley, the power is never less than that obtainable from a 5 in. double belt running at 1,666 ft. per minute. The net weight of the machine is 17,500 lbs. It

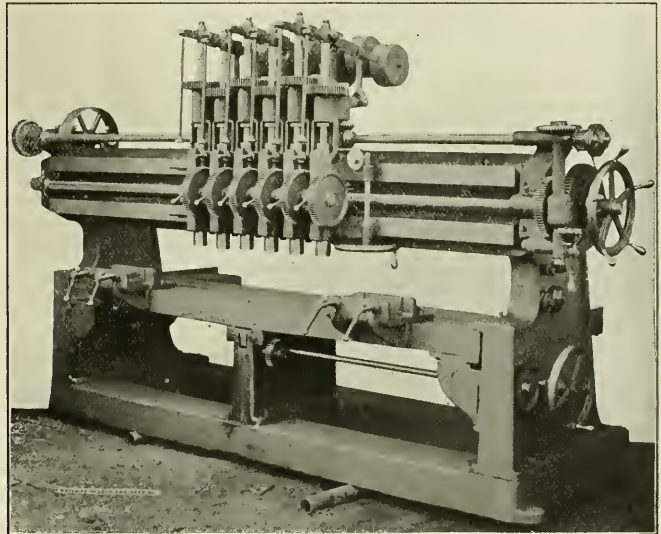

MULTIPLE MUD RING AND GENERAL SERVICE DRILL.

while it was designed especially for drilling mud rings it is equally well suited for all operations of multiple drill work. Instead of the heads sliding on an auxiliary rail, which is the ordinary way such machines are arranged, these move directly on the main rail, which enables them to be spread to any desired center distance, each head being provided with independent adjustment.

Where it is desirable that the heads should be adjusted collectively, such as for mud rings and similar work, the heads are clamped together by means of two quick-acting nuts which fix the center distance between spindles at 7 1/2, 8, 8 1/2 or 9 ins., as may be required. A dial on the worm wheel in the upper corner of the right hand head shows the distance through which the heads are moved to the right or left. The speed and feed changes are obtained by means

is, altogether, a very serviceable tool in a railway repair shop.

### The Bulldozer's Bluff Was Called.

BY SHANDY MAGUIRE.

The present winter being what is known as an open one so far, it would not be a fossilized idea to go back in our minds to the winters when old Boreas maintained a closed shop—which was every winter of the scribe's life until the present one. Last winter was severe enough to suit the fancy of an Arctic bear in these parts.

Along about the middle of February a year ago, we had a regular Klondike visitor for about 36 hours. The push plow was kept in motion on a snowy section of the J. P. & E., about 30 miles in length, and gave the maintenance of way department something to do to keep the "beautiful" clear of the track. After

the storm ceased, every available man was hired to assist in making a regular clean up.

Jack Carson, a young, strapping, stalwart lad, was section boss at Dayton, it being the terminal of the J. P. & E.

Jack was "monarch of all he surveyed" fighting snow, as he had made a record to be proud of. Once in a while, to cronies, he would confidentially unload, and hold sway on how the free horse can be ridden to death, as he was kept at night and day from the commencement of the storm until the shindy was over.

This particular storm I am telling of, after we supposed it had exhausted itself, took a new hold and blew javelins of icicles intermixed with the flakes, which were coming down with the ferocity of tigers trying to appease their hunger. All the force of fighters that Carson had were played out, and no bribery could get them to work another hour; and right there is where his troubles began.

About 3 P. M. the plow was ordered out again. Jack called for 15 men. A rush was made from the station platform to get on to the plow by that number of as fine holy terrors as you could cull out of a battalion of soldiers plundering a battlefield. They were dock-wallopers who, after the close of navigation, catch-as-catch-can for jobs at anything available. The railroads are always an easy mark for them, as they are expert sogers at daywork, but to their credit be it said, they are thoroughbreds at job work. The only fervent prayer they utter in the winter is for God to send plenty of snow, so they can get on the pay rolls of some company. Carson knew most of them, and didn't expect very good results. When about a mile out of town he fetched up in a cut, and sung out to them to jump and dig out the plow.

"We will if you give us our dinner when we get to Franklyn."

Carson stood on the steam chest to cut the engine from the plow, and see if she would back herself out, and was so astonished at the request that he nearly had an epileptic toe dance.

"Say, Stoney," he said to the spokesman, "this is no place for your funny work. Get out here everyone of you and dig out this plow, or I'll brain those who hang back."

"You'll raise hell in your own watch," sings out Puke Powers; "out of here we don't go one inch unless you promise to give us our dinners."

Jack saw he was up against it, and he decided to make the promise, hoping to double on them some way he would think up later.

The plow was dug out, and they fought their way to Ulton, four miles from the starting point. He stopped there and

wrote a message to the agent at Franklyn to have the proprietor of the only hotel there state that he could furnish nothing to eat to any but his regular boarders, on account of the storm. As he handed the message to the operator he was informed that Franklyn couldn't be raised. All Carson cared for was to punish the gang, even to the point of starvation, or freezing to near death if he could, but he knew that they had the upper hand and would hang on to the bitter end. The proprietor of the Cliff House, at Franklyn, stated to Jack that the best he could do was to give a dinner of corned beef, pork, cabbage, potatoes, bread and pie.

"Do you think that they are ex-millicinaires that I have? Why them fellows didn't get a square meal since navigation closed. They could lick the smell of a piece of meat trailed across the stove, and smack their lips with joy. Cut out the pie, corned beef and cabbage, then hustle a chunk of fat pork and Murphys at them, and watch them disappear."

They got a swell dinner. They then played a game of chin music for Carson to get the cigars, but he didn't bite.

They hustled right along to Dryden, the end of their trip through the snow belt, and got started back in good time. As the daylight faded, the storm took a new hold and blowed tremendous. It took them from 5 till 8.30 to get to Granger, about 22 miles, and they took the siding there to let train 18 pass. After waiting until 18 was about 20 minutes late, Carson went to the station to see if he could learn anything of its whereabouts. The wires being down, nothing could be learned. They were in working order between the train dispatcher and Granger, and sorry Jack was for it. He was tortured with questions relating to the belated train's whereabouts, which he could not answer. Over a private 'phone wire, between two farm houses and the station, the agent learned that 18 was stuck at Pine Grove, about two and a half miles from Granger. After a wait of another 20 minutes Jack got this message: "Feel your way over to Pine Grove with the plow and dig out 18; we have just got notice it is stuck there."

"Give me orders against her."

"I can't get her conductor. You will have to work your way over with a flag."

"You might as well be telling me to run a dark flag through a dungeon cellar full of black cats to find a mouse, as to talk of a flag in the storm that is screeching a devil's fury here just now. I'll not do it; I'll walk over there with the shovelers, if they'll come with me, and that is the best I can do."

"Well, why don't you go; and don't

# Tate Flexible Staybolt



Strong  
Effective  
Economical

Flexibility  
Durability  
Simplicity

Holds firebox sheets securely together, and accommodates itself to the unequal expansion of the plates.

## FLANNERY BOLT COMPANY

PITTSBURG, PA., U. S. A.

Suite 308, Frick Bldg.

B. E. D. STAFFORD, - - General Manager

Write us for Reference Book

**STANDARD MECHANICAL BOOKS  
FOR ROAD AND SHOP MEN  
BY CHAS. McSHANE**

**The  
Locomotive Up to Date**

Price, \$2.50

**New York and  
Westinghouse Air Brakes**

Price, \$1.50

**One Thousand Pointers for  
Machinists and Engineers**

Price, \$1.50

All books bound in fine cloth

AGENTS WANTED everywhere; write for terms and descriptive circulars. Will be sent prepaid to any address upon receipt of price.

**GRIFFIN & WINTERS**  
171 La Salle Street, CHICAGO

**Wm. R. Phelps & Co.**

MANUFACTURING JEWELERS.



High  
Class  
Watches,  
Diamonds,  
and  
other  
Precious  
Stones.

We make a specialty of  
Masonic and all other Emblems.

Diamonds purchased of us at present prices are a good investment. We have a fine line of the best Railroad Watches at rock bottom prices. Jewelry of every description.

**WM. R. PHELPS & CO.**

3a MAIDEN LANE, NEW YORK, N. Y.

be taking up so much time around the stove there?"

"That's a dirty slur," said Carson, "and could only come from the mouth of a fellow more used to hawbucking bulls than dispatching trains, to ask a man to flag his way such a night as this against a train of one coach and a combination car, with two heavy engines attached."

After discharging his stomach in the hearing of the hangers-on, who stood with mouths agape, Jack went to the plow.

He found the gang happy. The stove was booming; a song was singing, and encouraging expressions such as "Raise her, me thrush," "More power to yer bagpipes," "Divil may never run 'way with ye," and so on. A brief glance told Carson that every one of them had on a fighting jag, which left him dubious how to lead off.

"Come, boys, we will have to walk over to Pine Grove to dig out a train. Get your shovels and let us start."

"Where is Pine Grove?" says Puke Powers.

"About a mile or so from here; it won't take us long."

"Have we got to walk it?" asked Bruiser Johnson.

"Not if I can get a coupé or a barouche or a sufficiency of ladies' phaetons to carry you there."

"Well, be jakers, ye can hoof it over there yerself, and we'll be here when ye get back, for the divil an inch ye'll get us out of here to-night," says Puke again.

Carson saw that he was only wasting talk with them, and he decided to take the bull by the horns.

"Get out of this plow, every mother's son of you, inside two minutes, or I'll brain you. I have the same power over mutineers as a shipmaster in a case of this kind."

"Will ye give us our supper if we do?" says Rookie Smith, a big-nosed Swede.

Carson saw that he had to conciliate them, and he said: "If you'll get out and follow me to Pine Grove, I'll wire from there to Franklyn, where we got our dinner, to have supper ready."

"Well, see that you do," says Puke. "or ye'll find it will be worse for ye!"

After they all got out of the plow Carson locked the door so that they could not get back in. It was a wild night, blowing, snowing, drifting, and the thermometer about 20° below, by the feel of the cold.

"Now, boys," said Jack, "come here to the lee side of the plow, so you can

hear what I have got to say, before we start. I—"

"What are ye going to give us besides our supper for gettin' out such a night as this?" said Rookie. There were strange thoughts working through Carson's brain about this time, and he was ready to promise any old thing.

"If you strike a gait when we get started, I'll give each one of you a half-pint of old rye to lay the ground tier of your stomachs with."

"All right; let us hear what you are goin' to say."

"Now, men, remember what I am about to inform you. There are two big engines ahead of two coaches, stuck in the snow, about a mile or so from here. They are liable to get out and be coming along at any moment. We have got to keep our eyes open and our mouths shut, to hear them. I will lead the way; each one of you, singly, trail on behind; keep about four feet apart, and when you hear me sing out, 'jump,' don't wait to look, but jump to the right just as rapid-



WASHOUT ON THE LINE—BRIDGE GONE OUT.

ly as ever you moved in your lives, and keep going till you are sure to be clear of the track."

"Ah, go to the divil; de ye think we are goin' to get killed for 15 cents an hour?"

"Puke, you are the worst agitator of the crowd. You are not worth powder to blow you to hell; and if you open your cod mouth again to-night I'll punch it bigger than it is. Come, fall in behind me, all hands."

"To hell with ye," said the whole of them in chorus. "Dig the damned train out yerself."

"Boys, you are no cowards, whatever else you may be. I wouldn't blame you to kick if I said 'go.' I shall lead the way. I am the first to meet danger."

"You are well paid for it. We want double time or divil an inch we'll shank it for ye such a night as this."

"All right, gentlemen, come on," said Jack, nearly heartbroken.

The snow was about a foot on the level. Carson being first, had to break the road. The hind fellow had a good path. They started in the order Car-

THIS ILLUSTRATION SHOWS THE FORM OF CONSTRUCTION OF THE

## Dart Patent Union

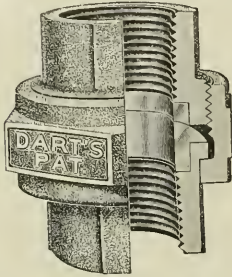

Every feature of construction represents the best points to insure stability and durability. The malleable iron pipe ends and nuts, in combination with bronze metal seats, are as near perfection as is possible to approach, and the sales to date indicate the public approval. There are none so good. For sale by all the principal jobbers in United States, Canada and Europe.

**E. M. Dart Mfg. Co., Providence, R. I.**

FAIRBANKS CO., SALES AGENTS

# SKAT

Best Hand Soap Known

UNEXCELLED for taking the SMUT and GREASE off RAILROAD men.

### AGENTS WANTED

An attractive offer awaits the first man in every town who answers this

**SKAT MFG. CO.**  
791 Park St. Hartford, Conn.

## Flexible Spout

Vertically in straight line. Also laterally. The latest improvement to

## Poage Water Columns

American Valve and Meter Company

CINCINNATI, OHIO

SEND FOR CATALOGUE—

son told them. They kept their shovels up to windward so as to protect their faces, and were not so uncomfortable after all, while poor Jack, without any protection save his cap, had to take it as it came. He would have abandoned his endeavors to get anything out of the gang, but for what was working in his mind. About half way from where they started and the stalled train was a pond that rarely froze over. The water was about 2 ft. deep, and a fairly strong current. The track was run over it on a 5 ft. fill. They all felt good, and started up what is known by sailors as a chantey called "Homeward Bound."

"Shut up your damned bazoos," said Jack, "how can I hear the train coming with that screeching?"

They trudged along silently for about 20 minutes, not saying anything until they all came to a full stop, swearing they'd go no farther unless the half-pint was made a pint. Carson promised, and just as they all got abreast of Dolan's Pond, as the place was called, he sang out in a voice which could be heard a quarter of a mile away over the shrieking of the gale:

"Jump for your lives, men! Jump!"

Down went every mother's son of them with the speed of the wind, and, owing to the 5 ft. of a bank, landing on their heads. After they got their heads above water Carson sang out to them: "Instead of a banquet at Franklyn, and a pint of old rye to top off, eat snowballs, condemn you, and while it is handy, top off with ice water."

With the speed of a liberated deer he scooted back to Granger over a regular boulevard, arriving there in time to get orders to go over to 18 regardless of all trains. He told his engineer to keep the whistle going continuously, in fear of them being pillars of ice, and not very spry to move. The train was released in short order when Carson got there. It was backed to the station, to let the plow pass, then went on its way.

A couple of days later Carson met Puke Powers, and learned that the gang roused out a farmer, whom they made get them supper and keep a good fire going all night to thaw them out. For many a day afterward, whenever Jack would meet one of them, his salutation was:

"Eat snowballs, d—n ye."

The Mechanical Index has recently changed hands. It has been bought by the Donnell-Colvin Company, of New York, and will be issued, as usual, but in improved form by the new company. The mechanical index is really a condensed catalogue of American manufacturers, and as a complete work of reference in this line it will be, we were going to say, "out of sight," but, on the contrary, it will be very much in evidence

# ALDON

CAR and ENGINE

## Replacers

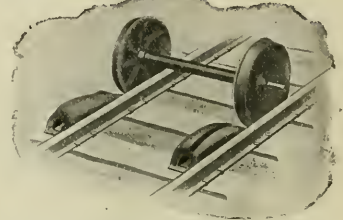

Sure, Safe and Quick Rerailing. A Wedge Without Moveable Parts. Slope so as to Clear Brakes or Sand Pipes. Rights and Lefts—Steel or Malleable Iron . . .

**The ALDON COMPANY**  
1103 Monadnock Block  
CHICAGO, ILL.

## Locomotive Engine Running and Management

By **Angus Sinclair** \$2.00 Best book in print for any railroad man.

**ANGUS SINCLAIR COMPANY**  
136 Liberty Street, New York

## A Practically Perfect Portable Pneumatic PUNCH

Stop moving your heavy work to the machine. One Man brings this tool to the work and punches it besides.

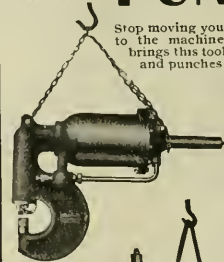

Punch Size 3

Built in 5 Standard Sizes. Special machines built to order. Write for Catalogue C.

**F. F. SLOCOMB & CO., Builders**  
WILMINGTON, DEL.

**SAVES TIME LABOR SPACE**  
Leading concerns in all parts of the country use this Punch.

# THE UNION SWITCH & SIGNAL CO.

Consulting and Manufacturing  
Signal Engineers

Automatic Block Signals—Electric  
and Electro-Pneumatic

Interlocking—Electric, Electro-Pneumatic  
and Mechanical

Electric Train Staff Apparatus

GENERAL OFFICES AND WORKS AT  
SWISSVALE, PA.

DISTRICT OFFICES:

New York: 143 Liberty Street  
Chicago: Monadnock Block  
St. Louis: Frisco Building

## QUINCY, MANCHESTER, SARGENT CO.

Succeeding { Q & C COMPANY,  
RAILWAY APPLIANCES CO.,  
PEDRICK & AYER CO.

SOLE SALE AGENT  
ELASTIC NUT OR BOLT CO.

Old Colony Building  
CHICAGO  
114 Liberty Street  
NEW YORK

{ Plainfield, N. J.  
Factories - Chicago Heights, Ill.  
{ Milwaukee, Wis.

Manufacturers of

Railway Machinery  
and Appliances

## PATENTS

Our Hand Book on Patents, Trade-Marks,  
etc., sent free. Patents procured through  
Munn & Co. receive free notice in the

SCIENTIFIC AMERICAN

MUNN & CO., 361 Broadway, N. Y.  
BRANCH OFFICE: 625 F St., Washington, D. C.

and will always be kept handy by those who use it. The Index is to deal exclusively with things mechanical, "mechanical tools and appliances," we are told. The authors of the circular letter announcing the purchase of this periodical modestly say of themselves that they know a "come-along" or a "quarterming level" are neither of them water tube boilers or "buzz planers," and that the information given will be correct with no fooling and no excuses. If the Donnell-Cole in Company do as they promise the Mechanical Index will very neatly fill a long felt want.

A new and extensive coal field has been discovered in Colorado. It is estimated that there are over 500 square miles which afford a thickness of more than 10 ft. of coal that can be worked. The Denver & Rio Grande Railroad are projecting a branch line into the district.

An important order recently secured by the Canadian Westinghouse Company was obtained from the Vancouver Power Company, of Vancouver, B. C. This order included a 1,500 h.p. 2,200 volt revolving field engine type generator, which will be direct connected to a Pelton water wheel. This is a duplicate of the generators now in operation in the power plant of this company, and will operate in multiple therewith. The order includes switch boards, air blast transformers of 550 K.W. capacity. There is also included in the order a 1,000 K.W. 60 cycle rotary converter to operate 550 volts. This converter will furnish power for railway work and will be controlled direct from the switchboard.

### Auto and Locomotive Race.

A tin locomotive on wheels, and a pasteboard automobile on wooden rollers, are creating the wildest excitement in one of our New York theaters. There is an invisible gold mine in the West somewhere, and an imaginary bundle of worthless bonds in the East, and suddenly both become priceless, and the villain gets into the locomotive, and the hero and the heroine into the automobile, and the wheels are set a-going, and the red fire lightens up the ragged moving scenery, and the screws in the heads of the audience become loose, and the whistle shrieks, and the tin horn blows, and the pin-wheels set off their revolving flashes of colored fire, and the atmosphere thickens, and the din and the delirium increase, and, of course, the villain is beaten by a nose, and the frowsy bundle of bonds is saved, and it will be fortunate if the fire brigade and the ambulances are not called in to add new features to the moving melodrama. The author makes a speech but the name of the machinist is never mentioned.

## WASHBURN COMPANY

Minneapolis, Minn.

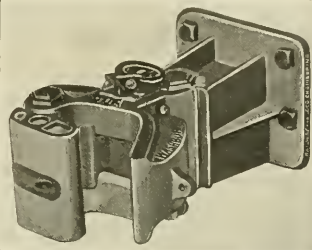

Automatic couplers for freight,  
engine and passenger service.

Draft riggings and buffer attachments  
for freight and passenger  
cars.

Special couplers for narrow gauge  
and plantation service a specialty.

Steel castings of all descriptions.

## Oil Burning in Locomotives

Is described in our new book,  
Care of Locomotive Boilers,

50c. - - This Office

## The Twentieth Century Master Mechanic

Won't use Solid Mandrels.  
Cost too much, take up too  
much room and don't give  
satisfaction.

### Nicholson Expanding Mandrels

Take everything from 1 to 7  
inch holes. Take up little  
room—always ready and  
you can buy four sets for  
the cost of one of the solid  
kind.

Are You Using Them?

Catalogue tells you  
more about them.

W. H. Nicholson & Co.  
Wilkesbarre, Pa.

# Locomotives, Freight and Passenger Cars

All equipment rebuilt in our Chicago shops, and at Scranton, Pa., in the new "Lackawanna" Shops

## All Kinds of Cars and Engines Ready for Immediate Delivery

RELEASED BY TRUNK LINES

1000-60,000 LBS. CAPACITY REBUILT FLATS AND GONDOLAS  
 2000-50,000 LBS. CAPACITY FLATS, BOX AND GONDOLAS  
 COACHES, COMBINATION AND BAGGAGE CARS  
 FOREIGN SHIPMENTS HAVE PROPER CARE OF  
 EXPERIENCED STAFF

Cable Address  
 "FITZLUTH"

55 AND 70 TONS CONSOLIDATIONS  
 45 AND 50 " 10-WHEELERS  
 40 TO 55 " MOGULS  
 45 TO 50 " PASSENGERS  
 SWITCHERS, FORNEYS AND SHAY ENGINES

### FITZ-HUGH, LUTHER CO., Monadnock Block, CHICAGO

14 BROADWAY NEW YORK      CHEMICAL BLDG. ST. LOUIS      80 ST. FRANCIS XAVIER ST. MONTREAL, CAN.      RIALTO BLDG. SAN FRANCISCO

## World's Fair

St. Louis

FIRST PRIZE FOR

## TOOL STEEL

AWARDED TO

## McInnes Steel Co.

CORRY, PA.

in competition with the best makes in England and Germany. Also manufacturers of all kinds of Tool Steel, Die Blocks, and Steel Forgings.

Write for Prices and Information



**GOLDEN YELLOW CALLA LILY, 5 Bulbs.**  
**50 KINDS 10c.**  
**SEEDS**  
 Asters, Balsam, Cannas, Calliopsis, Nasturtium, Burning Glory, Fines, Larkspur, Jolee Tears, Fanny, Golden Glow, Staphyraxos, Cosmos, Pink, Zinnia, Verbena, Money Plant, Sweet Rocket, Primrose, Ice Plant, Petunia, Custer, All Beans, Tortulosa, Candytuft, Sweet Peas.

**5 CHAMPION BULBS.**  
 The Summer Hyacinth, Golden Lily, Humming Bird, Gladiolus, Giant Tuberoses, Ruby Breath Oranals, all this beautiful collection of seeds and bulbs only 10c. in silver or 5 c. stamps to pay postage. Order quick and be sure of this grand offer—only 10c. each.

CHARLESTOWN NURSERY, - CHARLESTOWN, MASS.

The Hamilton Machine Tool Co., of Hamilton, Ohio, have got out a catalogue dealing with their planers and shapers. It is No. 5, and is printed on high grade paper and has a large number of very clear illustrations. The planers are of various sizes and kinds adapted to all sorts of work. There are twenty-three planers illustrated and several shapers shown with separate cuts for the various parts. Sizes are given, and a brief description accompanies each. The tools are made from recent designs and there is a safety locking device supplied, which prevents the accidental shifting of the belts when the planer table is stationary. This protects the operator from injury by an unexpected movement of the machine and saves the work from being marred. Write direct to the company if you would like one of these catalogues.

A neat little folder issued by the National Metallic Packing Co., of Oberlin, Ohio, has just come to hand. The packing shown is of the locomotive type and a half-tone illustration on outside of the pamphlet makes clear what it is. The packing is cast iron throughout and has no heavy springs to force the packing into the vibrating gap. After the piston rod has been packed with this metallic packing the cross-head may be moved by hand, we are told. This packing does not require the piston rod to be drawn from the cross-head in order that it may be applied. It is also made in sizes suitable for valve rods. To quote a few words from the folder— which, by the way, the company will send direct to anyone who applies for it: "The construction of the packing is such as to adjust itself to the irregularity of the piston rod. The guide bars or cross-head being out of line does not interfere with the proper working of the packing, which remains steam-tight under all conditions."

Metal in the manufacture of balloons seems a bold step, but three balloons are being manufactured in France for the United States Army, the outer covering of the silk bags being made of aluminum, a feature which contributes to durability as well as to lightness.

The number of locomotives employed on American railroads is estimated at 48,000. The total number built by the railways and the locomotive building companies in the United States last year was about 6,500.

Some people have a keener scent for grievances than the best breed of hound has for the trail of a deer. When the grievance hunt becomes hot it monopolizes the usefulness of those engaged in it.

### CONTENTS.

	PAGE
Air Brake Department.....	157
"Air Strainer, New.....	157
Book Notices:	
Link Motion, Valves and Valve Setting—	
Colvin.....	160
Modern Locomotive Engineering Handbook—	
Swingle.....	160
*Bridge, Black River, N. Y., C. & St. L.....	161
*Bulldozer's Bluff Called—Shandy Maguire.....	187
Car:	
"Drop-Bottom Gondola.....	183
Couplers, Object Lessons on.....	157
Difficult to Warn.....	147
Editorials:	
To Right a Heinous Wrong.....	158
Preserving Head Light Glasses.....	158
Machine Shop Reamers.....	159
Collision on the D. & R. G.....	159
Honest for Honey's Sake.....	159
Railroad Machinists.....	160
Costly Blunder.....	160
Accident Record.....	160
Electricity on Steam Railroads.....	177
*Fire Box Patches, Tight.....	187
*Fellow Servant Law, Proposed Bill to Change.....	160
General Correspondence.....	151
Government Ownership in Japan.....	181
*Head Light Glass, Preserved.....	187
*Holder-On, Water Space.....	174
Link Motion, Inventor of.....	178
Locomotives:	
*Oldest Locomotive (English).....	144
*Balanced Compound, N., C. & St. L.....	149
*B. & M. Consolidation.....	173
*Compound 4-4-2 Wind Splitter.....	179
*Mud Ring Drill.....	187
Correspondence School, Our.....	163
*Packing, Cutter for Continuous Length.....	181
Patent Office Department.....	125
Personals.....	125
Questions Answered.....	164
*Radius Planing.....	172
*Relief Valve, Pennsylvania.....	150
*Snow Plow, Rotary.....	171
*Tool Rack, Pyramid.....	162
*Valve Gearing, Walschaert—Jas. Kennedy.....	166
*Valves and Valve Motion, Development of—	
Angus Sinclair.....	154

# Railway and Engineering Locomotive

Copyright by Angus Sinclair Co.—1906

A Practical Journal of Railway Motive Power and Rolling Stock

Vol. XIX.

136 Liberty Street, New York, May, 1906

No. 5

## Schuylkill River Bridge.

There are few of the works of man which, from an artistic point of view, are ever thought to enhance natural scenery, but a bridge always seems to be an exception to this rule. The view which we present in our frontispiece this month

masonry spans 60 ft. across with piers 7 ft. through, measured in the direction of the railway track, and the abutments of the steel structure are 25 ft. through. As shown in our engraving, there are four 60 ft. masonry arches and five smaller ones 21 ft. 6 ins. span, resting on piers

Pratt truss deck bridge. It is called a deck bridge because the top chords carry the road, and it is spoken of as a Pratt truss because it is built, in a general way, after a design which was patented in 1844 by T. W. and Caleb Pratt. The original Pratt truss was built partly



BRIDGE OVER THE SCHUYLKILL RIVER AT PHILADELPHIA ON THE PENNSYLVANIA RAILROAD.

is from a photograph of the Pennsylvania Railroad Company's bridge over the Schuylkill river at Philadelphia. This structure is a double track, deck, pin-connected span, 236 ft. long and with a total weight of metal of 1,140,000 lbs. It was built by the American Bridge Company, of New York, some years ago.

The approaches to the bridge are

4 ft. through, and a pier 12 ft. through where the large and small arches join. This makes the masonry approach on the far side of the river about 420 ft. long, and that of those forming the approach on the near side of the bridge, which is not shown, make a length of about 280 ft.

The steel span is what is known as a

of wood and partly of iron, and had the upper and lower chords and the vertical posts of timber and the inclined members, except the two end ones, made of adjustable iron rods. About 1850 the Pratt truss came to be built entirely of iron, and in that form has been very popular with bridge builders.

The bridge over the Schuylkill river is

built of eye-bars with pin connections at the ends. These pins are about 8 ins. in diameter, with a  $1\frac{1}{4}$  in. hole bored through the center. The truss itself is 25 ft. 9 ins. deep, and is fixed at one end and placed on rollers at the other, so that

the efficiency of the details is worthy of the boldness of the conception." There was a previous attempt to build a bridge at Lyons, in France, in the year 1755, but the work was never completed. The Society of Arts awarded

- Murray & Hazelhurst, Baltimore, Md.
- Ross Winans, Baltimore, Md.
- Back Bay, Boston, Mass.
- John Souther Works, Boston, Mass.
- Hinkley and Williams Works, Boston, Mass.
- Seth Wilmarth, Boston, Mass.
- Mason Machine Works, Boston, Mass.
- McKay & Aldus, Boston, Mass.
- McLeish & Smith, Charleston, S. C.
- Harkness Works, Cincinnati, Ohio.
- Moore & Richardson Works, Cincinnati, Ohio.
- Cuyahoga Works, Cleveland, Ohio.
- Bailey & Co., Connellsville, Pa.
- Covington Works, Covington, Ky.
- Detroit Locomotive Works, Detroit, Mich.
- R. L. Stevens, Hoboken, N. J.
- Grant Works, Hoboken, N. J.
- Breeze & Kneeland, Jersey City.
- Lancaster Works, Lancaster, Pa.
- Norris Brothers, Lancaster, Pa.
- Lawrence Machine Works, Lawrence, Mass.
- Louisville Works, Louisville, Ky.
- Locks & Canals Co., Lowell, Mass.; begun 1834.
- McKeesport Car & Foundry Co., McKeesport, Pa.
- Nashville Mfg. Co. Works, Nashville, Tenn.
- Seth Boyden, Newark, N. J.
- Newcastle Works, Newcastle, Del.
- Dunham & Co., New York.
- W. T. James, New York.
- West Point Foundry, New York.
- Summer, Graves & Day, New York.
- Watchman & Bratt, New York.
- Swinburne Works, Paterson, N. J.
- New Jersey Locomotive & Machine Works, Paterson, N. J.
- Norris Brothers Works, Philadelphia, Pa.
- Sellers & Son, Philadelphia, Pa.



FIRST IRON BRIDGE EVER BUILT.  
(Courtesy of the Valve World.)

as it grows longer in hot weather and shorter in cool, there will be only one end where this motion becomes apparent, and suitable rail joints are provided at that point so as to make the track continuous. The original idea in connection with this bridge was to have built three stone arches in place of the steel span, each of these arches would have been 70 ft. across with two stone piers in the water, but this has not been done, and the main channel of the river is crossed by the railway on the steel truss. The bank seen in the distance, where the small masonry arches stand, is the original and old bank of the river, which, in course of ages, has cut a deeper and a narrower channel for itself. The total length of steel span and both approaches gives a length of about 936 ft.

When we look at a modern steel bridge we seldom think of the many previous attempts which were made to build metal bridges and which mark the progress of the art. The illustration of the first iron bridge shows an arched structure which spans the Severn near Coalbrookdale in England. This bridge was built in 1779 and was composed of castings made at the Coalbrook iron works. It was 100 ft. span and was made of two castings. Robert Stephenson is reported to have said of it, "If we consider that the manipulation of cast iron was then completely in its infancy, a bridge of such dimensions was doubtless a bold as well as an original undertaking, and

a gold medal to Abraham Darby, the builder of the English bridge, in recognition of his achievements.

**Locomotive Building Works That Have Passed Away.**

Railroad people interest themselves so much in locomotives that they generally like to know about the concerns that have built locomotives in the past but follow the industry no more. A veteran master mechanic has sent us

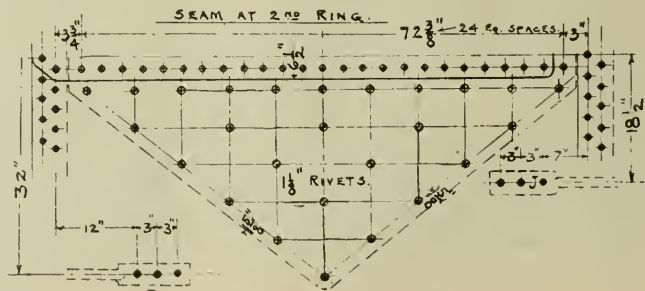

LONGITUDINAL SEAM WITH DIAMOND SHAPED WELT—OREGON SHORT LINE BOILERS.

the following list of locomotive building works that have passed away. As the list is intended for the pages of Sinclair's "Development of the Locomotive Engine," we should be obliged to our readers for additions or corrections.

- Smith & Perkins, Alexandria, Va.
- G. W. Johnson, Baltimore, Md.

- McClurg, Wade & Co., Pittsburgh, Pa.
- Eastwick and Harrison Works, Philadelphia, Pa.
- Portland Machine Works, Portland, Me.
- Dotterer Works, Reading, Pa.
- Rothwell Hicks & Co., Richmond, Va.
- Burr & Co., Richmond, Va.



New York Locomotive Works, Rome, N. Y.

Risdon Iron Works, San Francisco, Cal.

Union Iron Works, San Francisco, Cal.

Vulcan Iron Works, San Francisco, Cal.

Palm & Robertson Works, St. Louis, Mo.

Taunton Machine Works, Taunton, Mass.

Trenton Works, Trenton, N. J.

Davis & Gartner, York, Pa.

#### Single Expansion 4-6-2 for the O. S. L.

The Oregon Short Line Railroad is one of the roads which form what has been called the Harriman system. In that group are included the Southern Pacific, the Union Pacific, the Leavenworth, Kansas & Western, the Oregon Railroad & Navigation Co., and the Oregon Short Line. This latter road has lately purchased from the Baldwin

of this engine are flanged, and all the driving springs are overhung. The tractive effort of this machine is about 28,160 lbs., and, with 141,000 lbs. on the drivers, the ratio of tractive effort to adhesive weight is as 1 is to 5. On the cab, which is made of steel, the name of the road appears, and underneath is painted the figures 77 $\frac{2}{3}$ 141. This looks something like a mathematical formula, but it is, as our readers may guess, information, in condensed form, concerning the wheels, cylinders, and adhesive weight which we have already given.

The boiler is a straight top one, with semi-wide fire box; that is, it extends considerably beyond the frames while not being as wide as a Wootten box. The grate area is 49 $\frac{1}{2}$  sq. ft. The barrel of the boiler is 70 ins. in diameter at the smoke box end, and is composed of three courses lapped, telescope fashion, at the circumferential seams. These seams are double riveted, as is

tenth one. The crown sheet is stayed by a series of crown bars made of T-steel, into which the staybolts are screwed. A series of similar T-bars are secured to the roof sheet, and slings unite them to the crown bars.

The tender has an ordinary steel frame, and the tank, with its water bottom, has a water capacity of 9,000 U. S. gallons and holds 10 tons of coal. The principal dimensions of this engine are as follows:

Boiler—Thickness of sheets, 11/16 and 3/8 in.; working pressure, 200 lbs.; fuel, soft coal.

Fire Box—Material, steel; length, 108 ins.; width, 66 ins.; depth, front, 68 ins.; depth, back, 64 ins.; thickness of sheets, sides, 3/8 in.; back, 3/8 in.; crown, 3/8 in.; tube, 3/2 in.

Water Space—Front, sides and back, 5 ins.

Tubes—Material, iron; wire gauge, .125 M. M.; number, 245; diameter, 2 1/4 ins.

Driving Wheels—Diameter, 77 ins.; journals, main, 10x12 ins.; others, 9x12 ins.

Engine Truck Wheels—Front, diameter, 33 1/2 ins.; journals, 6x10 ins.; back, diameter, 45 ins.; journals, 8x12 ins.

Wheel Base—Driving, 13 ft. 4 ins.; total engine,

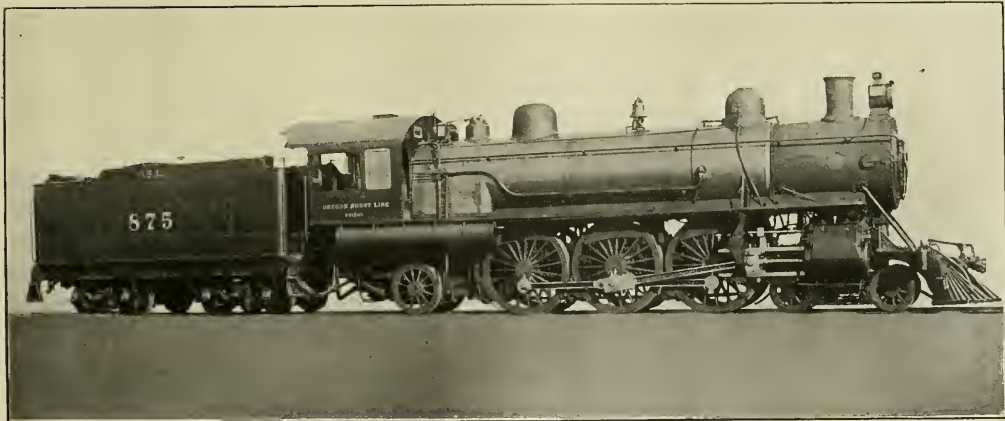

PRAIRIE TYPE ENGINE FOR THE OREGON SHORT LINE.

J. E. Dunn, Superintendent of Motive Power.

Baldwin Locomotive Works, Builders.

Locomotive Works twenty-eight single expansion engines similar to the one shown in our illustration. These engines are of the 4-6-2 or Prairie type, and they have been built in conformity with the general practice of these companies regarding the interchangeability of parts, in order to have them conform as far as possible to the standards adopted by the Harriman Associated Lines.

The cylinders are 22x28 ins., and the valves are of the piston type, driven by indirect gear. The driving wheels are 77 ins. in diameter, and the main drivers are the center pair. The eccentrics are on this axle, and a transmission bar is made with an inverted U-shaped curve and spacing ferrule, and is carried round the front driving axle and thus joins the link block to the rocker. All the wheels

usual in locomotive boilers, for the sake of stiffness as well as strength, and in this boiler the longitudinal seams are all placed in line along the top and reinforced with the Vauclain diamond shaped welt, which gives the joint the strength of 96 per cent. of the solid plate. The boiler is a long one, and the tubes measure 20 ft. There are 245 of them, and they give a heating surface of 2,874 sq. ft., and with that of the fire box, which is 174 sq. ft., there is a total of 3,048 sq. ft. An ordinary box car, such as the one we illustrated on page 116 of our March issue, has about 320 sq. ft. of surface on one side with the door shut. The heating surface of this engine would about equal the surface that you could see when viewing the sides of a string of nine box cars and half of the

33 ft. 4 ins.; total engine and tender, 63 ft. 10 1/2 ins.

Weight—On driving wheels, 141,000 lbs.; on truck, front, 37,000 lbs.; on truck, back, 44,000 lbs.; total engine, 222,000 lbs.; total engine and tender, about 384,000 lbs.

Tender—Wheels, diameter, 33 1/2 ins.; journals, 5/2x10 ins.

Service—Passenger.

#### Building Three.

Three locomotives are being built at the Juniata shops of the Pennsylvania for the use of three officials of that system. One is for the use of the president, Mr. A. J. Cassatt, another is for Mr. W. W. Atterbury, the general manager, and the third will be for the service of Mr. George W. Creighton, general superintendent. The engines will be capable of making fast time, which is probably what will be expected of them whenever they are in service.

## Development of Valve and Valve Motion.\*

BY ANGUS SINCLAIR.

### PART THREE.

After the link motion had been introduced into Great Britain and the United States, there was for many years little disposition manifested to make improvements except in minor details. The principal objection manifested to the link motion in Great Britain was its causing increase of lead when notched up. In the United States, where small driving wheels were the rule, this tend-

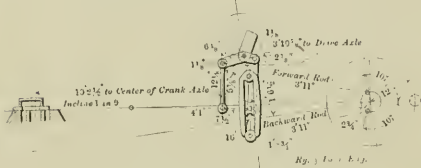

FIG. 29. ALLAN STRAIGHT LINK.

ency to increase the lead was regarded as a merit rather than a defect, but in Britain it led to the inventing of several motions that produced constant lead or very little increase of the same. Among the motions thus invented, the best known was the Gooch, Fig. 26, which appeared in last month's issue, first used by Rogers, and the Allen or straight link, Fig. 29. Both have their good points, but the curved shifting link known as the Stephenson is almost universally used in the United States. Early locomotive builders and master mechanics experimented to some extent with the novel link motions mentioned, but they did not find any reason to deviate long from the shifting link.

#### WHERE RADIAL VALVE GEARS WERE POPULAR.

The locomotive engineers of the continent of Europe did not, however, feel moved to accept the link motion as all that could be desired. From the beginning of the railway era they displayed partiality for some sort of radial motion, a species of movement that appeals to certain minds with geometrical tendencies. About 1840 Hensingier von Waldegg introduced into Germany, and Walschaert into Belgium, a form of valve gear now known as the Walschaert motion, which has gained high popularity on continental railways.

This motion has been exhaustively illustrated and described in RAILWAY AND LOCOMOTIVE ENGINEERING during the last two years, and reference is made to pages 534 of the 1904 volume; 63, 439 and 535 of 1905 volume.

\*This is part of a historical article for my forthcoming book, "Development of the Locomotive Engine." If readers find mistakes of facts they will oblige me very much by pointing them out.  
ANGUS SINCLAIR.

#### FIRST RADIAL MOTION USED IN AMERICA.

Radial valve motions of various kinds have been repeatedly tried by American locomotive builders, but somehow they generally returned to the link. Early in the 40's the Niles Locomotive Works, of Cincinnati, built some locomotives for the Beaver Meadow Railroad, now a part of the Lehigh Valley Railroad, and they were equipped with a radial valve gear that had a small return crank and a connection with the crosshead to drive the valve. It was designed by John L. Whetstone, then superintendent of the Niles Locomotive Works. It was not the Walschaert motion, but was of the same general type. There did not appear to be serious objections to the motion, but no other engines except those made by the Niles people were equipped with it.

#### VARIOUS RADIAL MOTIONS.

Another radial gear with one eccentric was patented by John Wesley Hackworth, son of Timothy Hackworth, the famous pioneer locomotive engineer, in 1859. The gear had no run of popularity, because British locomotive builders were satisfied with the link motion, but it had features that would have made it a serious competitor of the Walschaert gear under favorable circumstances.

It does not come within the scope of this work to describe the Hackworth motion in detail, but people interested will find full particulars beginning on page 92 of the Eighteenth Annual Report of the American Railway Master Mechanics' Association.

Another radial gear that was applied to many continental locomotives was developed by Charles Brown, of the Swiss Locomotive & Engine Works, at Winterthur, Switzerland. A full illustrated description

of this gear will also be found in the report of the American Railway Master Mechanics already referred to.

#### JOY'S MOTION.

To finish with European railway valve gear, I may mention that in 1879 David Joy patented his valve motion illustrated and described on pages 55, 56 and 57 of RAILWAY AND LOCOMOTIVE ENGINEERING of February, 1906. This gear has found favor on several British railways, and is growing in popularity, having many recommendations for engines with inside cylinders.

There were so many concerns that engaged in the work of locomotive building in the first four decades following 1830 that the most select mechanical ability of the country was devoted to the improvement of the locomotive. This was frequently manifested in the invention of curious valve motions that were applied to a few locomotives and then disappeared. As these appliances, although frequently very ingenious, exercised no permanent influence upon the locomotive, it is not necessary to go into particulars.

#### MASON'S WALSCHAERT MOTION.

About 1875 William Mason began applying the Walschaert valve motion to locomotives, and many engines were so equipped, particularly those built for narrow gauge railways. The arrangement he used is illustrated in Fig. 30.

The main link *N* was worked from a crank in the main crank pin, which was several inches outside of the center line of the cylinder. To keep the center line of the valve seats inside of the center of the cylinders, the lever *P O* worked from the crosshead, and to which the radius arm *N P* was coupled, was connected to the block *Q*, which was bolted to the guide bar *R S*. The lever *P O* was connected to the outside of the block *Q*, which was fastened to the guide bar, and the valve stem *T* was attached to it on the inside. By this means the motion of the lever *P O* was transferred to the center of the valve stem and valve seat, which was  $3\frac{1}{2}$  ins. inside of the center of the cylinder.

As the point of suspension of the radius arm *N P* has a great influence on the motion of the valve, the upper end of the link *U V*, to which the radius

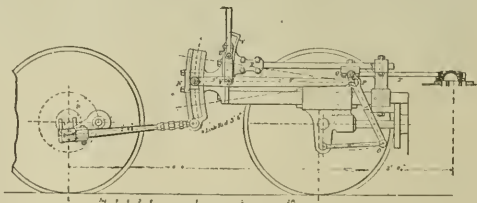

FIG. 30. WALSCHAERT VALVE GEAR AS USED BY WILLIAM MASON.

arm was hung, was attached to a block which worked in the slot of a stationary link or guide *W*. By that means the point of suspension *U* conformed to the curve of the slot, producing nearly uniform distribution of steam at both ends of the cylinder.

Mason's Walschaert valve gear was illustrated and described in a report presented to the Railway Master Mechanics' Association convention in 1885. From the remarks made about it, we judge that sentiment among master mechanics was decidedly opposed to the motion.

What I learned from people in charge of locomotives at that time having the Walschaert valve gear, led me to think that ignorance concerning the adjustment of the mechanism was at the bottom of the opposition to the motion. The common talk was, it has too many joints, and that the pins wore rapidly, defects which were not beyond a remedy, had the desire to keep the motion in use existed.

EARLY PENNSYLVANIA RAILROAD VALVE MOTION.

Baldwin's people built for the Pennsylvania Railroad a lot of engines that

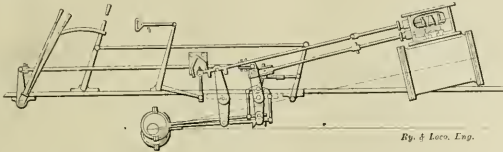

FIG. 31. EARLY PENNSYLVANIA RAILROAD VALVE MOTION.

were well known in the early 50's, which had the valve motion shown in Fig 31. The valves were worked by single V-hooks, the cut-off being a positive half stroke working upon a partition plate. The outer end of the valve rod ended in a sort of drop hook which, by means of a lever and tumbling shaft of its own, could be lifted from or placed on the pin at the top of its own rocker arm. The arrangement of the motion can be readily understood by a study of the engraving.

SECTIONAL PREJUDICE FOR EARLY MECHANISM.

In the early days of railroading and locomotive building in the United States, in the days before the Railway Master Mechanics' Association made the whole country a unit of practice, certain sections adhered to their own fads and fashions. New England kept turning out inside connected engines long after they had ceased to be accepted in other sections, and New England was the last to give up the drop hook.

CUT-OFF VALVES.

Nearly all New England locomotives of the 1850 period had cut-off valves. The cut-off was a simple open valve, like a throttle, in a separate steam chest above that of the regular slide valve, and might be adjusted to stop the flow of steam into the cylinder at any desired part of the stroke, which was sometimes one-half or two-thirds. These valves were actuated by eccentric rods and rocker arms similar to those of the main valves, and were thrown out of action when starting by means of a lever in the cab.

A device was introduced a few years before the invention of the "link motion" called "Gray's cut-off," by which the steam could be stopped or cut off at any part of the stroke, and could be varied at will by a lever in the cab. This was done by attaching the valve rod to a block which worked in a slot in the upper rocker arm. This device met with much favor, but was rendered useless when the "link" was adopted.

A sketch of the interesting motion shown in Fig 32 was sent to me by Walter S. Phelps, Muncie, Ind. The main valve had ports for steam passage

into the cylinders through openings at the ends. Over this was a riding cut-off valve, with openings shown. The cut-off valve was actuated from the cross-head by mechanism resembling Joy's motion. A stand was erected upon the frame and held the swinging arm that gave motion to the valve.

The principal objection to this form of cut-off motion was that few mechanics in its day were capable of adjusting the valve movement. When it was wrongly adjusted it failed to admit steam at the right time.

BALANCED VALVES.

The first trend of improvement on valve motion displayed in America after

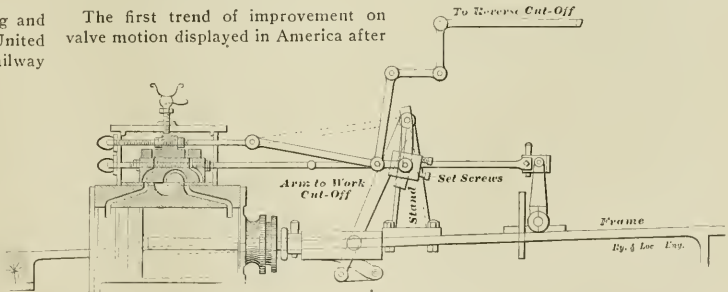

FIG. 32. GRAY'S CUT-OFF MOTION.

the introduction of the link motion was in favor of balanced valves. The reports of the annual conventions of the American Railway Master Mechanics' Association furnish a reliable history of the efforts made to perfect valve motion after 1870.

A sentiment arose that moving unbalanced slide valves involved exaggerated waste of power, and a variety of inventions offered remedies and substitutes. In the Annual Report of the Master Mechanics' convention of 1870 twelve forms of balanced and anti-friction

valves were mentioned. Arrangements of rollers came considerably into use, the valves moving on the rollers. Rotary valves of various novel forms were tried, and several peculiar arrangements for balancing the valves. The most popular balancing arrangement was invented about 1870 by G. F. Morse, superintendent of the Portland Locomotive Works. The balancing arrangements were the most satisfactory provisions for reducing the friction of slide valves, but they did not become popular as long as the valves were small. About 1880 balanced valves gradually began to come into favor, and a few years afterward "balanced valves" became a regular item of specifications for new locomotives.

RICHARDSON BALANCED VALVE.

About 1880 George Richardson, noted as the inventor of the pop safety valve, made an improvement upon the Morse balancing device which greatly increased its efficiency and brought it rapidly into popularity. By means of steamtight strips secured on the top of the rectangular valve the Richardson balance relieves a certain proportion of the top of the valve from pressure.

AMERICAN BALANCED VALVE.

In 1893 the Wilson American Balance Valve began to come into use, and it has gradually grown in popularity until it now divides the business with the Richardson balance valve. By the Wilson invention the relief of pressure on top of slide valve is effected by a circular plate kept tight by packing rings.

PISTON VALVES.

In 1898 the Brooks Locomotive Works began recommending piston valves, and that form of valve is now becoming very common. In many instances the piston valves admit steam on the outside edges of the heads, making the action practically the same as the flat slide valve. In other instances admission of steam is made between the heads and the exhaust steam escapes at the ends. Both arrangements have merits and drawbacks peculiar to themselves.

## DEMAND FOR IMPROVED STEAM DISTRIBUTION.

The objections originally urged against the link motion, that it produced slow admission and early release of steam, experienced a temporary revival in the United States about 1870. Men well informed on steam engineering began arguing that a valve motion ought to open the steam port rapidly, cut off promptly when the required volume of steam was admitted, then open for release when the stroke of the piston was nearly completed, and open wide enough to prevent back pressure. They also wanted the valve kept open during release long enough to produce

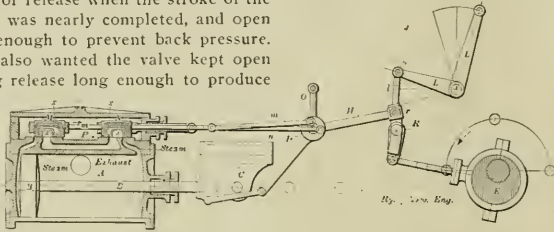

FIG. 33. A. J. STEVENS' VALVE MOTION.

very little compression. These were functions the link motion performed rather imperfectly.

Locomotive engineers shared the belief, still prevailing among steam engineers generally in America, that simple engines with properly devised valve gear could use steam to greater advantage than through the more expensive compound engine. The advantage that comes from preventing extremes of cylinder temperature had not been generally recognized.

## A. J. STEVENS' VALVE MOTION.

The first notable attempt to overcome these reputed shortcomings of the link motion was made by A. J. Stevens, of the Southern Pacific Company, and is illustrated in Fig. 33. This valve gear was applied to many locomotives by the inventor, and had a high reputation for efficiency. The motion was a modification of the Hackworth gear, and double valves were used, with Allen supplementary passages for both admission and release.

The combined motion of a single eccentric and crosshead lever imparts movement to a sort of wrist plate *D*, which actuates two valve stems, one for each valve. Under this arrangement the valve opens sharply for admission till the port is wide open, and in that position it remains for an instant and then closes quickly. It was an ideal valve motion, performing the functions of quick opening of port, quick cut-off, protracted release and small compression, all the movements having been remarkably rapid.

I believe that had a company, powerful enough to push its merits before railroad officials, taken up this motion in 1883, it would have become the standard valve motion of nearly all American railroads.

## DAVID CLARK'S EFFORTS.

About the time Mr. Stevens designed that gear, David Clark, of the Lehigh Valley Railroad, brought out a locomotive valve gear with an independent cut-off, the main valve being driven by a link motion, as shown in Fig. 34. The gear and indicator diagrams taken from a locomotive equipped with it are illustrated in the Eighteenth Annual Report of the

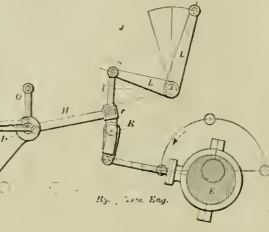

American Railway Master Mechanics' Association. The diagrams, two being shown on page 199, are probably the finest ever taken from a locomotive, and have the clean cut points commonly made by the best forms of automatic cut-off engines. They are mar-

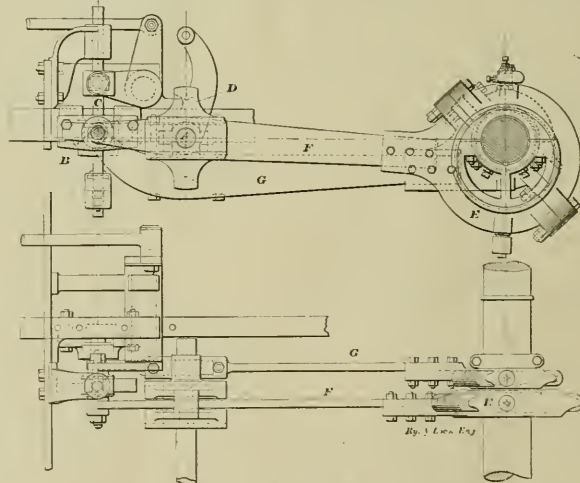

FIG. 35. WILLIAM WILSON'S VALVE MOTION.

velous indicator diagrams, and the engine ought to have done its work with the smallest possible volume of steam; but, strange to say, it never did the work with the same economy of fuel as link motion engines engaged on the same service.

This gear called for six eccentrics and rods, four rocker shafts, two reverse levers and rods, and two additional valves, valve seats, valve stems and stuffing boxes. The motion produced very pretty indicator diagrams and pro-

moted scientific conversation among mechanical engineers.

Study of the valve motion of locomotives impresses us with faith in the poet's lines that

"There are more things in heaven and earth

Than are dreamt of in your philosophy."

## WILLIAM WILSON'S VALVE MOTION.

Another very ambitious attempt to improve the valve motion of locomotives was made in 1885 by William Wilson, mechanical superintendent of the Chicago & Alton Railroad. The motion shown in Fig. 35 is of the radial gear type, but the movement of the valve is taken entirely from a single eccentric, and its rod fulcrumed so as to produce an ellipse. In the main, the device consists of the eccentric *E*, its rod *F*, the reversing gear *D* and the upright actuating rod *C*, attached to the rock shaft operating the valve rod. The motion is taken from the eccentric, to which is attached the fulcrumed rod, the fulcrumed bearing *A* passing over or through guides in the reversing shaft, which is supported on the radius bar *G* to equalize or correct the inequalities of the motion caused by the vertical

movement of the driving boxes. This shaft is held in boxes, and is connected by an arm to the reverse lever, and can be partly rotated in its bearings by the movement of the reverse lever. While the reverse lever is in mid gear the guides on this shaft stand in a horizontal position, and therefore the fulcrum of the eccentric lever travels in a horizontal direction. Any movement of the reverse lever back or forward throws the guides on the reversing shaft out of the horizontal position, and

at an angle either one way or the other. The direction in which it is thrown controls the direction of the movement of the engine, and the distance it is thrown controls the travel of the valve. The rear end of the eccentric rod has the same motion as the eccentric, and the forward end or point *B* describes

with the motion used more coal doing certain work than did engines of the same general dimensions equipped with the link motion.

Two years later Mr. Wilson still further elaborated his valve gear, but it did not induce any other person besides the inventor to use it.

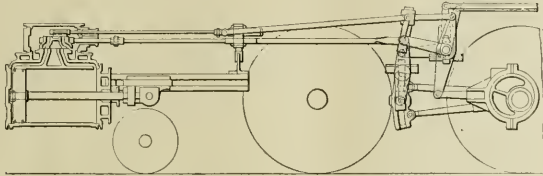
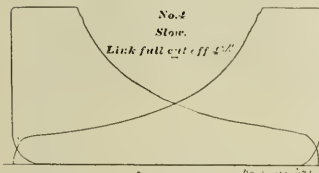
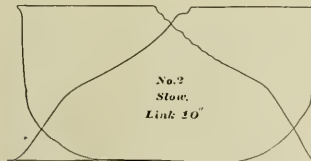

FIG. 34. DAVID CLARK'S VALVE MOTION.

an ellipse whose length corresponds with the throw of the eccentric, and whose diameter is regulated by the position of the reverse lever. The smallest diameter of the ellipse, or that described when the reverse lever is in the center notch, must be twice the lap and lead of the valve.

When the piston of an engine equipped with this gear is on the dead center, an imaginary line passing through the center of the eccentric rod fulcrum would also pass through the center of the reversing shaft. Therefore any movement of the reversing shaft on its axis would not stir the eccentric rod, and a constant lead is maintained, no matter where may be the point of cut-off.



INDICATOR DIAGRAMS FROM ENGINE EQUIPPED WITH CLARK'S VALVE MOTION.

The special merits claimed for the motion are quick opening and closure of ports, a constant lead, a correct and equal cut-off, exhaust opening and exhaust closure with protracted release while cutting off early.

Indicator diagrams taken from the motion demonstrated that the claims of the inventor were well founded, so far as the distribution of steam was concerned, but the locomotives equipped

STRONG'S LOCOMOTIVE IMPROVEMENTS.

About the time that William Wilson was sacrificing himself upon the valve motion improvement altar, George S. Strong, of Philadelphia, made a series of very persistent attempts to provide a substitute for the link motion. He tried several kinds of motion, but finally settled upon a radial gear of the Hackworth order actuating gridiron valves, its elements being shown in Fig. 37. His idea was to produce a gear which under almost all conditions of speed would give uniformity between boiler and admission pressure, doing away with wire drawing and reducing the back pressure to the lowest limits. Independently worked valves were used for admission and exhaust.

A company was formed to put upon the market locomotives having this valve gear and other novel features worked out by Mr. Strong. Two engines were built and did service of an advertising character on various railroads. No demand arose for that kind of locomotive.

REJUVENESCENCE OF THE WALSCHAERT VALVE MOTION.

During the year 1904 one or two railroad companies tried the Walschaert valve motion for heavy engines because, being located outside of the running gear, it was much more convenient to reach than link motion. Walschaert motion immediately became the fashion and the indications are that it will be applied to many locomotives in future.

There are several odd forms of valve motion before the railroad world at present, but nothing likely to effect a revolution.

MARTYRS TO VALVE MOTION INVENTING.

As long as inventive ability is active among us, and opportunities exist for reducing the volume of steam required to produce a unit of power in the locomotive or other steam engine, there will be new inventions developed with the hope of capturing the profits that ought to be given to those whose de-

VICES prevent wasted effort. There seems to be something very alluring in the work of attempting to make improvements on valve motion. It resembles the craze for gambling or that of indulging in stimulants. Among the men mentioned as working to improve the valve motion, some were veritable martyrs to their ambition. One in particular, who held an excellent position, became so infatuated in developing valve motion combinations that he ruined his usefulness as a railroad official and went to a premature grave protesting against the short-sightedness of those who had withdrawn their support of what they called his wild vagaries.

New Form of Sleeping Car.

The traveling public have become accustomed to call all sleeping cars Pullmans, but things will eventually change in this direction if the American Palace Car Company's style of sleeper makes the progress which it seems likely to do.

The new car is practically a chair car in the daytime, having movable seats

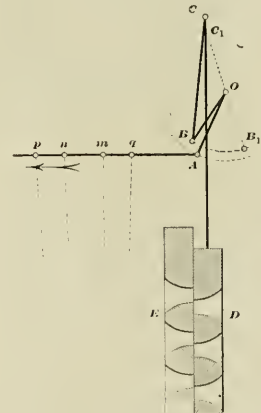

FIG. 36. STRONG VALVE GEAR.

ranged along both sides. As one steps into the car it has nothing about it to indicate that it can be used as a sleeper.

The secret of this pleasant daytime appearance of the car is the fact that all the beds and bedding are out of sight beneath the floor. When it is necessary to make up a section, one or two beds can be made ready as required. The first operation is to move the chairs temporarily out of the way. Then the porter lifts up a portion of the floor, which is found to be hinged below the carpet, and this, when placed vertically and bolted there, makes one of the upright walls of the section; a second similar "area" lying immediately below the first is raised up like a trap-door and makes the second wall of the section.

This raising up of these "floor areas",

which makes them become partitions, reveals the presence of a box or well below the floor, called by the builders

longing to the section are put into the berth pocket, and any hand baggage belonging to the passengers can be stored

plenty of light. This is true, because, there being no upper berth shut up on a slant all day, the windows are constructed so as to reach the highest level, and are so arranged that at night there is always the upper part of the window which can be opened or closed, cleared or shaded at will by the occupant of the upper berth. There is thus more ventilation and a greater volume of free air in this car all the time than is found in other sleepers. In the day, when the beds are down out of sight below the closed up floor, a current of pure outside air is allowed to get at the beds all the time. It passes through dustproof screens, and the beds get an all day airing, and at night are sweet and clean, and moreover they are made up and ready for use the moment they are wanted.

This car has as yet not become a victim to the idea that an upper berth set in place at night is a thing to be insisted upon at all times. If a passenger pays for one section, he can have the upper berth pulled up to the level of a lower, and have the space above him clear. In any event, there is a greater distance between upper and lower berths in this car than usually exists in ordinary sleepers.

This car would be very convenient for an invalid, simply because the berth upon which he may desire to lie can be placed on the floor level or at any desired height, and either raised or lowered after he is in bed. The lifting

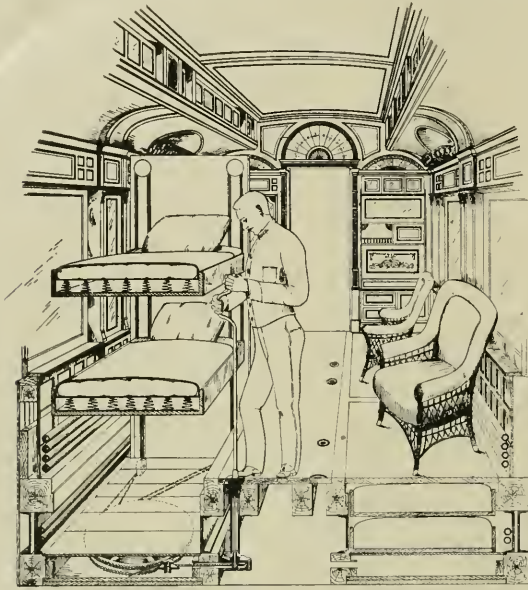

SECTION OF COACH SHOWING METHOD OF LIFTING BEDS AND STEEL BERTH POCKET BELOW CAR FLOOR.

a steel-lined berth pocket, in which the beds and bedding are securely packed. The berths are raised by a very ingenious mechanism, the work being done by a porter, who applies a long crank handle socket wrench to the "square" at the top of a vertical rotating shaft. At the bottom of this shaft is a sprocket wheel and chain very similar to that used on a bicycle.

The rotation of the sprocket turns a large flat-wheel below the floor of the berth pocket, and round this wheel wire cables are wound which are carried up over a pulley on each of the walls of the section, and at the ends of these cables the berth hangs. Both upper and lower berths are raised by separate mechanisms, but the large flat wheels, for there are two of them, below the berth pocket, work on the same shaft. When the berths are raised to the required height they lock on the vertical walls, and there is no chance of their sliding down.

The lower berth, like the upper one, is not a sort of couch, but a regular ventilated spring mattress affair, for in this car chairs are chairs and beds are beds, and though the internal arrangements of the car may, so to speak, turn day into night or night into day, there is no effort made to compel a patron to sleep on what was once a seat, or to sit on what was once part of a bed. When both berths are in place, the chairs be-

there also. A flap which covers the space between the bottom of the lower berth and the car floor prevents things



AMERICAN PALACE CAR DAY COACH AND SLEEPER, SHOWING ONE BERTH MADE UP AND TWO BERTHS IN SECTION BEYOND.

required in the car from falling into this space.

There are several advantages claimed for this form of sleeping car construction by those interested, and there is, of course, the obvious claim that there is

mechanism contains a locking device which operates when the porter withdraws his wrench. This lock secures the berth at any desired height. When in the regular position the berth also locks against the walls of the section.

# General Correspondence.

## Value of the Brick Arch.

Editor:

The Baltimore Sun of February 27, 1906, contained a news item of a hearing, by a committee of the Maryland Legislature, of advocates and opponents of an "Anti-Smoke" bill, among the latter being the counsel of the Pennsylvania R. R. and Mr. W. W. Atterbury, its general manager, who, in the course of his remarks in opposition to the bill, is reported in the Sun to have made the following statement:

"The brick arch is the most effective, but it so destroys the efficiency of locomotives that we have had to discontinue it. I say that these so-called smoke consumers are frauds and am prepared to prove it."

The general press is often inaccurate as to technical matters, and it may well be that Mr. Atterbury has not been correctly reported. If, however, the statement above quoted was made by him, it is somewhat difficult to understand upon what grounds he bases the opinion expressed. The extended use of the brick arch on most of the principal railroad lines of the country would seem to indicate that their managers consider that the efficiency of soft coal burning locomotives is enhanced by the use of the brick arch, and when the same is properly applied and maintained, this has always been the opinion of the writer. The matter is suggested in your columns in the hope of eliciting an expression of views as to the correctness of the statement attributed by the Sun to Mr. Atterbury.

J. SNOWDEN BELL.

New York, N. Y.

## Leaking Dry Pipe.

Editor:

Your Question and Answer Department is always of much interest to me because of the variety of new matter which it always contains, and I often wonder how you manage to answer so many puzzling questions. A month or so ago you explained an ingenious method of testing a leak in a throttle valve or dry pipe. It was a clever idea to cover the dry pipe with water and then watch the cylinder cocks for steam or water. We had a case exactly similar when we had steam locomotives on the road, and the method we adopted involved a little more work, but was very effective. We had a bad leak in a throttle reported time and time again, so after grinding the throttle valve several times, with no improvement, we grew desperate, and an inspiration came to us. We

took off the dome cap and jammed down the valve and loosened an oil pipe near the steam chest and coupled it to a steam hose in the roundhouse, after getting both slide valves over the ports, and blew back a steam pressure into the dry pipe, then took a torch and felt around the stand pipe and dry pipe joint, and the leak at the joint promptly blew out the torch. The mystery was solved. The throttle valve was all right.

placed a full set of tires from a six-wheel switching engine at a cost of 22 gallons of gasoline at.....	.25	\$5.50
1 machinist, 6 hrs.....	.30	1.80
1 machinist helper, 6 hrs....	.20	1.20
1 machinist helper, 6 hrs....	.15	.90

\$9.40

This does not include labor stripping and replacing the parts necessary to do the work. I do not suppose that I

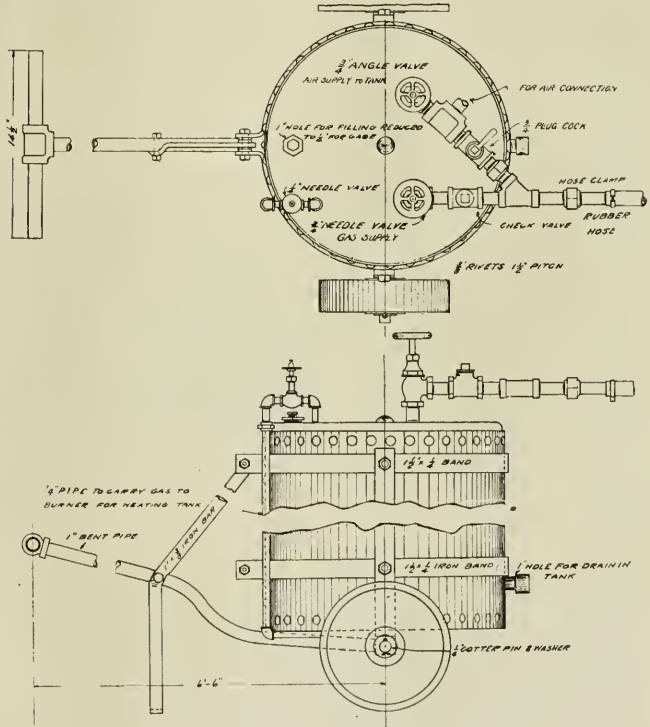

PORTABLE GASOLINE BURNER FOR TIRE REMOVING.

Due apologies were made to the various skilled mechanics who had had a turn at grinding the valve, and the pipes were taken apart and properly refitted.

W. G. CYPHERS.

Interborough R. T. Shops, New York.

## Gasoline for Tire Removing.

Editor:

I have perfected an apparatus for removing and replacing locomotive driving wheel tires with gasoline, which is very economical in the use of gasoline and, I consider, an immense saving of labor. For instance, I removed and re-

could secure a patent on the apparatus, as it is only a system of piping. However, thinking that your readers might be interested, I send this statement of cost, and sketch showing the apparatus.

W. T. FOSTER,  
Master Mechanic.

Copperhill, Tenn.

## What Was the Matter?

Editor:

A Schenectady cross compound in pusher service on a western road had air pipe from pump broken, so that separate exhaust could not be operated,

but engine was continued in service without giving any trouble, with but one exception. At a water tank at commencement of pusher district the compound got in behind caboose, pushed slack together in train, and stopped with throttle open, waiting for engineer on head end to start.

After about a minute the pusher engineer was surprised to see caboose going away from the pusher and leaving her standing with throttle open and

her? Can any of your readers throw any light on the matter?  
*Grand Forks, Minn.*

VIKING.

**Fast Work on an Old Lathe.**

Editor:

In your January number of RAILWAY AND LOCOMOTIVE ENGINEERING I noticed an article called "Tire Turning Extraordinary," by George S. Hodgins, the work being done with a new Niles-Bement-Pond driving wheel lathe

You will please find enclosed some cards of an ordinary 79-in. Niles driving wheel lathe, driven by a 30-h.p. electric motor, in the shops of the Chicago, Rock Island & Pacific at Moline, Ill. The face plate of our machine is fitted with driving wheel adjustable arms, constructed to hold driving wheel in lathe, perfectly rigid and close up to face plate, the distance being about 8 ins. This makes a very solid drive. This driving wheel driver is the inven-

TIRE TURNING TEST—MADE ON A 1903 NILES 69-INCH WHEEL LATHE.  
 East Moline Shops, Chicago, Rock Island & Pacific Railway, March 6, 1905.

Kind of Tool.	Size of Tool.	Tire Diameter and Kind.	Ft. Per Min.	Feed Per Rev.	Depth of Cut.	Distance Traversed.	Condition of Tool.	Cutting Time in Mins.	Mins. Chng Wheel.	Total Time.
<b>1st Pair</b>										
Novo.	1 1/2 x 2 ins.	Standard 48 1/2 ins.	12 to 20	3/8 in.	3/8 in.	1 1/2 ins.	Bad			
Novo.	1 1/2 x 2 ins.	Standard 48 1/2 ins.	12 to 20	3/8 in.	3/8 in.	1 1/2 ins.	Bad			
Styrian.	1 1/2 x 2 ins.	Standard 48 1/2 ins.	12 to 20	3/8 in.	3/8 in.	4 1/2 ins.	Good			
Rex-A.	1 1/2 x 2 ins.	Standard 48 1/2 ins.	12 to 20	3/8 in.	3/8 in.	4 1/2 ins.	Good	50	9	59 Mins.
<b>2d Pair</b>										
Styrian.	1 1/2 x 2 ins.	Standard 48 1/2 ins.	11 to 15	3/8 in.	3/8 in.	4 ins.	Bad			
Midvale.	1 1/2 x 2 ins.	Standard 48 1/2 ins.	11 to 15	3/8 in.	3/8 in.	2 1/2 ins.	Bad			
Rex-A.	1 x 2 ins.	Standard 48 1/2 ins.	11 to 15	3/8 in.	3/8 in.	1 1/2 ins.	Good			
Rex-A.	1 x 2 ins.	Standard 48 1/2 ins.	11 to 15	3/8 in.	3/8 in.	3 ins.	Fair			
Rex-A.	1 x 2 ins.	Standard 48 1/2 ins.	11 to 15	3/8 in.	3/8 in.	2 ins.	Fair			
Rex-A.	1 x 2 ins.	Standard 48 1/2 ins.	11 to 15	3/8 in.	3/8 in.	1 1/2 ins.	Good	62	6	1 Hr. 8 Mins.
<b>3d Pair</b>										
Rex-A.	1 x 2 ins.	Standard 48 1/2 ins.	14 to 16	1/4 in.	1/8 in.	3 1/2 ins.	Good			
Rex-A.	1 x 2 ins.	Standard 48 1/2 ins.	14 to 16	1/4 in.	1/8 in.	3 1/2 ins.	Fair			
Rex-A.	1 x 2 ins.	Standard 48 1/2 ins.	14 to 16	1/4 in.	1/8 in.	1 1/2 ins.	Good	55	7	1 Hr. 2 Mins.
<b>4th Pair</b>										
Rex-A.	1 x 2 ins.	Standard 48 1/2 ins.	13 to 15	1/4 in.	1/8 in.	3 1/2 ins.	Bad			
Midvale.	1 1/2 x 2 ins.	Standard 48 1/2 ins.	13 to 15	1/4 in.	1/8 in.	1 1/2 ins.	Bad			
Rex-A.	1 x 2 ins.	Standard 48 1/2 ins.	13 to 15	1/4 in.	1/8 in.	Flange and Contour	Fair			
Rex-A.	1 x 2 ins.	Standard 48 1/2 ins.	13 to 15	1/4 in.	1/8 in.	Flange and Contour	Fair	59	6	1 Hr. 5 Mins.
<b>5th Pair</b>										
Rex-A.	1 x 2 ins.	Midvale 58 ins.	14 to 18	1/4 in.	1/8 in.	1 1/2 ins.	Point broke			
Rex-A.	1 x 2 ins.	Midvale 58 ins.	14 to 18	1/4 in.	1/8 in.	1 1/2 ins.	Point broke			
Rex-A.	1 x 2 ins.	Midvale 58 ins.	14 to 18	1/4 in.	1/8 in.	3 ins.	Fair			
Rex-A.	1 x 2 ins.	Midvale 58 ins.	14 to 18	1/4 in.	1/8 in.	3 ins.	Fair			
Rex-A.	1 x 2 ins.	Midvale 58 ins.	14 to 18	1/4 in.	1/8 in.	Flange and Contour	Good			
Midvale.	1 1/2 x 2 ins.	Midvale 58 ins.	14 to 18	1/4 in.	1/8 in.	Flange and Contour	Good	64	5	1 Hr. 9 Mins.
<b>6th Pair</b>										
Rex-A.	1 x 2 ins.	Midvale 58 ins.	14 to 20	1/4 in.	1/4 in.	4 ins.	Bad			
Rex-A.	1 x 2 ins.	Midvale 58 ins.	14 to 20	1/4 in.	1/4 in.	Complete Tire	Fair			
Rex-A.	1 x 2 ins.	Midvale 58 ins.	14 to 20	1/4 in.	1/4 in.	Flange	Bad			
Rex-A.	1 x 2 ins.	Midvale 58 ins.	14 to 20	1/4 in.	1/4 in.	Contour	Good	56	8	1 Hr. 4 Mins.
<b>7th Pair</b>										
Rex-A.	1 x 2 ins.	Midvale 58 ins.	15 to 18	1/4 in.	1/4 in.	3 1/2 ins.	Fair			
Novo.	1 1/2 x 2 ins.	Midvale 58 ins.	15 to 18	1/4 in.	1/4 in.	Complete tire	Fair			
Rex-A.	1 x 2 ins.	Midvale 58 ins.	15 to 18	1/4 in.	1/4 in.	Flange	Bad	56	7	1 Hr. 3 Mins.
<b>8th Pair</b>										
Novo.	1 1/2 x 2 ins.	Midvale 58 ins.	14 to 16	1/4 in.	1/8 in.	Revolutions	Bad			
Novo.	1 1/2 x 2 ins.	Midvale 58 ins.	14 to 16	1/4 in.	1/8 in.	Complete Tire	Fair			
Novo.	1 1/2 x 2 ins.	Midvale 58 ins.	14 to 16	1/4 in.	1/8 in.	4 ins.	Bad			
Rex-A.	1 x 2 ins.	Midvale 58 ins.	14 to 16	1/4 in.	1/8 in.	Flange and Contour	Good	41	6	47 Mins.
<b>9th Pair</b>										
Novo.	1 1/2 x 2 ins.	Midvale 58 ins.	15 to 18	1/4 in.	1/4 in.	2 ins.	Bad			
Rex-A.	1 x 2 ins.	Midvale 58 ins.	15 to 18	1/4 in.	1/4 in.	3 1/2 ins.	Bad			
Rex-A.	1 x 2 ins.	Midvale 58 ins.	15 to 18	1/4 in.	1/4 in.	2 ins.	Fair			
Rex-A.	1 x 2 ins.	Midvale 58 ins.	15 to 18	1/4 in.	1/4 in.	Flange and Contour	Fair			
Novo.	1 1/2 x 2 ins.	Midvale 58 ins.	15 to 18	1/4 in.	1/4 in.	3 Revolutions	Bad			
Midvale.	1 1/2 x 2 ins.	Midvale 58 ins.	15 to 18	1/4 in.	1/4 in.	Flange	Bad			
Rex-A.	1 x 2 ins.	Midvale 58 ins.	15 to 18	1/4 in.	1/4 in.	Contour	Good	55	7	1 Hr. 2 Mins.
<b>10th Pair</b>										
Rex-A.	1 x 2 ins.	Midvale 58 ins.	14 to 18	1/4 in.	1/4 in.	3 1/2 ins.	Bad			
Novo.	1 1/2 x 2 ins.	Midvale 58 ins.	14 to 18	1/4 in.	1/4 in.	3 1/2 ins.	Bad			
Rex-A.	1 x 2 ins.	Midvale 58 ins.	14 to 18	1/4 in.	1/4 in.	2 ins.	Bad			
Rex-A.	1 x 2 ins.	Midvale 58 ins.	14 to 18	1/4 in.	1/4 in.	Flange and Contour	Fair			
Rex-A.	1 x 2 ins.	Midvale 58 ins.	14 to 18	1/4 in.	1/4 in.	Part of Flange	Bad			
Rex-A.	1 x 2 ins.	Midvale 58 ins.	14 to 18	1/4 in.	1/4 in.	Part of Flange	Bad			
Novo.	1 1/2 x 2 ins.	Midvale 58 ins.	15 to 18	1/4 in.	1/4 in.	Flange and Contour	Bad	54	6	1 Hr.

Actual weight of scrap taken from tires, 1,665 lbs.

10 Hrs. 19 Mins.

not willing to move an inch. As these engines have peculiarities of their own, the engineer looked down and saw low pressure crank pin on, or just below, back center. Not a position to give trouble from stuck reducing valve. In his despair he gave the throttle another pull, with the result that safety valve on low pressure steam chest started blowing, and, rabbit-fashion, the pusher started after the caboose, which by this time was about 75 ft. away. It is needless to say that the occupants of the caboose, as well as the engineer, got interested in the compound for a while at least. But what was the matter with

at the West Albany shops of the New York Central. The machine used at West Albany was of the latest and heaviest type, weighing about 120,000 lbs., and driven by a 40-h.p. electric motor, guaranteed for 50 per cent. overload; 58 to 60 h.p. was actually required, turning 15 pairs of driving wheel tires, ranging in diameter from 50 to 72 ins., in 804 minutes, or an average of 53 3/4 minutes per pair, removing about 3,000 lbs. of metal in the 804 minutes. That was certainly good work, and a lathe output never before accomplished, but where certain results are obtained others try for like results.

tion of F. E. Fox, then general foreman at the Moline shops, but now master mechanic of the C., R. I. & P. shops at Cedar Rapids, Iowa.

You will also find a table of work performed by this 79-in. Niles driving wheel lathe in a test made at the Moline shops on the 6th day of March, 1905, in which was accomplished the turning of ten pairs of driving tires, the greater number of them being 58 ins. in diameter, removing 1,665 lbs. of metal in 619 minutes. The machine used was an ordinary 79-in. driving wheel lathe, fitted with a 15-h.p. electric motor. The advantage in work performed by this



lathe is due to the driver on face plate of lathe; the work is held rigid in the machine and free from chattering. I am of the opinion that an ordinary belt driven wheel lathe, fitted up with these

lighting up about six cents an engine. Some months ago Mr. C. F. Richardson, general road foreman of equipment, arranged to substitute wood shavings for the kindler, and at present all

grates, and mixing in with the oiled shavings a couple of shovelfuls of slack or fine coal, the mass is shoveled into the fire box on top of the coal, and subsequently ignited by throwing in a piece of lighted waste. This makes a quick fire, with no danger of stuck grates. The regulation steam jet in stack is used to hurry the process. Our engines generate steam of 50 lbs. pressure in thirty to fifty minutes from cold water; in fact, as fast as it is advisable to do so, without doing damage to sheets and staybolts.

One of our master mechanics, Mr. J. M. Johnston, who is an enthusiastic advocate of shavings and fuel oil for kindling, unable to secure shavings, and casting about for a substitute, tried cotton seed hulls and found them to be a splendid substitute, using less oil, on account of the natural oil remaining in the hulls. This material is now being used in the cotton country with decided advantage.

Prior to the use of oil, the average cost of wood per fire was thirty cents. The labor and annoyance of handling wood cars, which block the engine tracks, generally inadequate for legitimate purposes, was considerable. The use of fuel or crude oil for kindling eliminates the expensive consumption of headlight and signal oil, often taken from the engine supply by fire builders to light wet, green wood. This is an item of expense that cannot be readily reckoned.

EUGENE McAULIFFE,  
Fuel Agent, St. L. & S. F.

St. Louis, Mo.

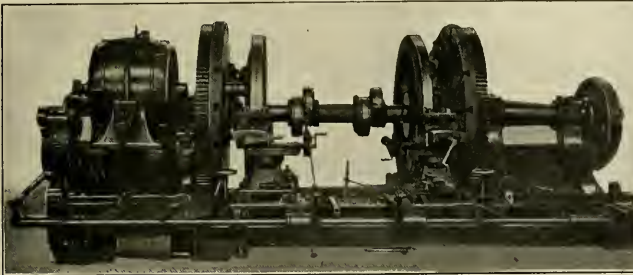

79-INCH MOTOR DRIVEN NILES' CEMENT-POND WHEEL LATHE, C. R. I. & P. SHOPS.

adjustable drivers, is capable of an output of five or six pairs of driving wheels per day. These drivers or dogs have no bolts to get loose, nor do they require any wedges driven in between wheel spoke and driver, but are so constructed that the greater the pressure put on drivers the tighter they hold.

ALLAN McDUFF,  
Cedar Rapids, Iowa.

**Cotton Seed Hulls and Oil.**

Editor:

About three years ago the St. Louis & San Francisco Railroad installed storage tanks of approximately 9,000 gallons' capacity at the principal engine terminals. These tanks are used for storing fuel oil, a substitute for cord wood in kindling locomotive fires. In the beginning, portable kindlers, the tank of which was made from an ordinary driver brake auxiliary reservoir, with gas pipe fittings and a fish-mouthed burner, also made from gas pipe, were used, and compressed air was used to atomize the oil. The oil used is the residuum from the oil refineries, the volatile properties having been taken out, and the heavy paraffine and carbon base remaining.

To start a fire, a layer of coal about 4 ins. in thickness was distributed evenly over the grates; and the burner, inserted through the fire door, drove a sharp flame down on the coal, the operator moving the burner around, igniting the whole layer of coal. This process took about five minutes' time and consumed from two and one-half to four gallons of oil, which cost, including freight and handling, about two cents a gallon, making the average cost for

principal terminals are using the fuel oil and shavings exclusively. A box, preferably of light steel plate, oiltight,

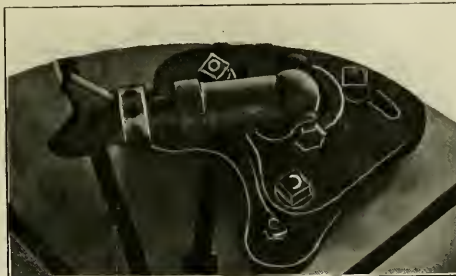

WHEEL DRIVE ON 79-INCH LATHE.

with a hinged cover, and holding about 40 cu. ft., is used to hold the shavings, which are mixed with oil until they are

Editor:

The pointer that appeared in RAILWAY AND LOCOMOTIVE ENGINEERING some months ago about removing a broken

**Broken Studs.**

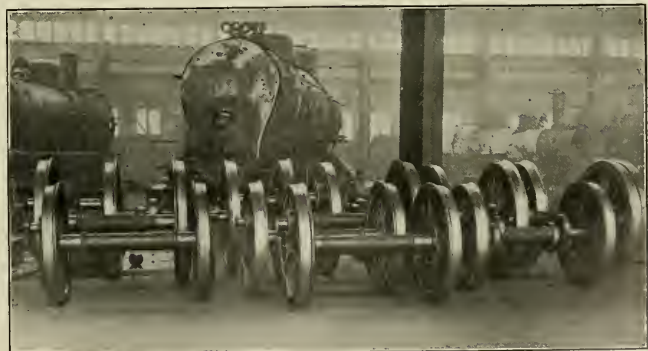

ALL IN THE DAY'S WORK, TEN PAIR IN TEN HOURS.

saturated but not soaked to the point of dripping. Two or three bucketfuls of this mixture are dumped on the shoveling sheet of the tender, after a light layer of coal has been deposited on the

stud was very good, but other suggestions might be offered.

Very often when a stud or set screw is broken off there is no drilling apparatus at hand; and even if these were to

be had, they could not easily be brought into play. Resort is usually had to the backing-out chisel—an ordinary round nosed chisel blunted in the cutting edge. If the broken screw is not too tightly wedged into the hole the mechanic may succeed in getting the broken part backed out a thread or two, so that a Stilson wrench or an alligator will take a hold and complete the process. Again, if the



TWO CHISELS MAKE IT MOVE.

broken piece refuses to move, a way out of the trouble may be found by using two chisels at once upon the refractory screw. Of course, two chisels means two mechanics working in unison and applying force in the same direction at opposite sides of the circular face of the broken screw, as in the accompanying illustration. Two hammers working simultaneously will probably exert a force much more than twice as great as one hammer striking single blows, since in the latter case the impact of the blow does not pursue a circular course, which is necessary to overcome the retarding influence on the opposite side of the screw.

The method of removing a broken screw or plug by drilling and inserting a square drift is not as well understood as it might be, and a word of caution may not be out of place. If a brass plug is to be removed from an iron or steel socket the way is easy and clear. Drill a hole of a size proportionate to the size of the broken screw, drive in a square steel drift fairly tight and screw the stud or plug out with the aid of a monkey wrench. But if the conditions are reversed and an iron or steel stud

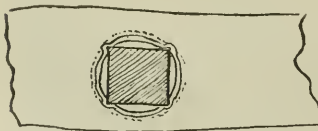

IRON STUD IN BRASS OFTEN BINDS.

is broken off in a piece of brass, care must be taken not to make the hole in the stud too large, or if the drift be driven in too tightly the harder metal of the stud having only the support of the soft brass about it, will assume the shape of the square drift, and, consequently, will not turn in the hole when a wrench is applied to the drift. Drill a hole safely small and then drive in a hard steel drift with sharp corners, or else partially square the hole with a cape chisel or file before inserting the drift.

W. L. CALVER.

I. R. T. Co., New York.

## Shop Kinks.

Editor:

Enclosed you will find a sketch of a couple of Mr. McAttee's shop kinks. These kinks are several months old now, but in the several months of use here they have demonstrated themselves to be worthy of a trial by any machine man.

The sketch, Fig. 1, represents an iron ring used in chucking cast iron barrels that are to be cut up for snap rings. Fig. 2 represents barrel with ring attached.

When a cast iron barrel is chucked in the lathe by pinching the jaws on the outside or inside of same without this ring, the tendency is to spring the barrel out of shape at chuck end, and in so doing the last two or three inches next to the chuck will not be round when taken out of the chuck. Now, if the ring in question is used, the untrue ring is a thing of the past.

The barrel is put into lathe as of old, by catching same with jaws of chuck,

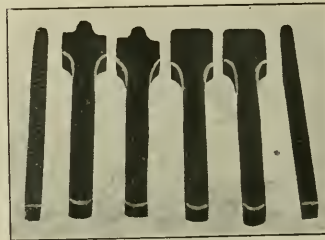
TOOLS USED FOR TIRE TURNING,  
EAST MOLINE, C. R. I. & P.

inside or out, and the opposite end of same is turned off for about one inch, just enough to true up or to fit the inside of the iron ring. The ring is driven over the turned end and put into the lathe, and the jaws put inside of the barrel, and they can be spread inside of the barrel as tight as one can pull and not spring the barrel, as the ring is wide enough to resist the strain. When these rings are turned here the barrel is used up to within  $\frac{1}{2}$  in. of the ring, and the last ring is as true as the center ones. This not only makes perfect rings but uses up all the barrel. This ring is 1 in. thick and 3 ins. wide, made of wrought iron.

Fig. 3 represents a pair of tongs used for picking up work for planers or boring mills, etc. For lifting cylinder heads on boring mills it is a preventative for smashed toes when the tongs are spread on the outside. For putting front end rings upon the boring mill the tongs are turned back to back and put inside of door opening.

J. W. PERCY.

South Tacoma, Wash.

## Prevention of Cruelty to Boilers.

Editor:

For some time I have been closely scanning the columns of RAILWAY AND LOCOMOTIVE ENGINEERING in hopes of finding a report of the performance of the De Glehn compound now in use on the Pennsylvania road. On account of

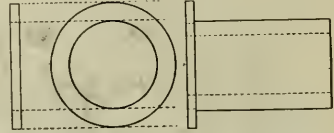

FIG. 1. IRON RING. FIG. 2. BARREL.

its superior valve motion, fine balancing and compounding features, which are carried out with a nicety of detail peculiar to French practice, I look for this engine to show a high degree of efficiency in coal economy, speed and smooth running, as compared with American machines of the same weight and dimensions. Please publish a report of tests as soon as available.\*

For several years it has been my custom to make what I term "biennial inspection tours," partly for recreation and partly to observe the conditions and practices on other roads. These trips have included such roads as the Lake Shore, Michigan Central, Big Four, Illinois Central, Burlington, Union Pacific and Southern Pacific. During this time I have talked with a great many enginemen. None of them complained of being underloaded. Indeed, if asked to express my own opinion, I would feel constrained to say that, with the exception of a few limited trains, the general rule seems to be a 100 per cent. engine on a 110 per cent. train.

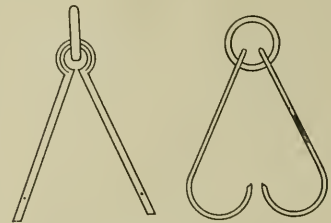

FIG. 3. TONGS FOR PICKING UP WORK.

The paper on care of locomotive boilers by M. E. Wells, traveling engineer of the Wheeling & Lake Erie—my old home road, by the way, where I spent many happy days on the little Mason bogies, under Master Mechanics James and Dunbar—struck a responsive

\*The Pennsylvania Railroad authorities are not at present desirous of making any statement for publication respecting the performance of the De Glehn compound, as they are still collecting data on the subject.—Ed.

chord in my breast. For if there is one hobby I like to ride better than another it is the theme of coal economy and care of boilers. Mr. Wells' paper has been furnished to the men in pamphlet form by our company. There is great interest taken in it, and it is bound to be productive of great good.

I have long been a self-constituted agent of the Society for the Prevention of Cruelty to Boilers, in which capacity I have often deemed it necessary to climb up on an engine on the clinker pit and remonstrate with the hostler for working the injector while the fire was being knocked out. Luckily for me, they were always good friends of mine, and I never got a short answer from any of them. But, to quote a line from a well-known parable, "They all began

smoke stack and incidentally cooling him off during its progress. This is a practice I never saw in the East. It may be necessary, but it is hard on the boiler.

But the worst sin of all is blowing an engine off, washing her out and filling her with cold water, and turning her out ready for the road in four hours. To paraphrase a classical English poet: "Eternal infamy the wretch confound Who planted first this vice on Yankee ground."

A good motto for those contemplating membership in the S. P. C. B. would be: If you can't be good to a boiler, be as good as you can.

The application is this: If you are a hostler, and get a chance to fill a boiler before reaching the clinker pit, do so.

things gradually drop into the old rut. I have often questioned backsliders as to the reason of their fall from grace. They have invariably charged it to the company, advancing such cogent arguments for their position that I have been unable to successfully combat them. Let the good work go on.

JAMES H. DAVEY.

Norfolk, Va.

#### French 4-6-0 Compound.

The engine shown in our illustration is one of a series built by the Société Alsacienne de Constructions Mécaniques for the Paris-Orleans Railway. The first fifteen were constructed in 1903, fifteen in 1905, and fourteen this year, either built or building. The whole forty-four are practically identi-

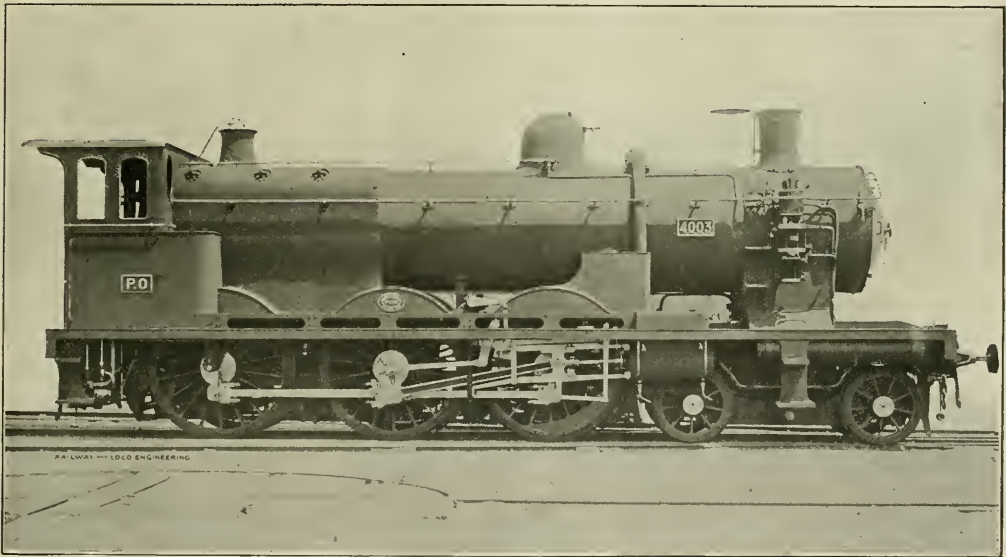

COMPOUND TEN-WHEEL, ENGINE USED ON THE PARIS-ORLEANS RAILWAY.

with one accord to make excuse." It is well known that the fire-up man is ready to eat a hostler that brings an engine in without the boiler full to the dome; and where so convenient a place as the clinker pit? The fire knocker, too, is usually a big, husky individual with decided ideas of his own concerning the use of a blower; so the hostler, in the interest of peace, discreetly allows these worthies to have their own way.

Frequently when passing through a roundhouse I have heard the strenuous blast of the blower with no apparent cause visible. Getting up into the cab to investigate, I would find the boiler-maker working on the flues, with a good, stiff current of cold air on its way from the fire box door to the

If by any rare chance you get a fire knocker that is amenable to the voice of reason, advise him as to the ill effects of a blower to the flues and side sheets.

If you are a boiler-maker, put off work on a hot fire box as long as you can and yet get it done in time. It is no uncommon thing to see a man work in a hot fire box that does not go out for a day or two. The same applies to boiler washing. Let the boiler cool off five or six hours first, where practicable, and enginemen will rise up and call them blessed.

During my railroad career I have been an interested participant in several spasmodic coal and boiler revivals. I liken them to a church revival. They do lots of good while they last, but

cal, except that the last four are fitted with piston valves. These engines are employed for heavy express work, and can haul a 500-ton train without difficulty at a speed of 50 miles an hour.

There are two high pressure and two low pressure cylinders, the dimensions of which are given below. Among the fittings are two Friedmann injectors, a Detroit lubricator for the cylinders, Adams type safety valves blowing off at 225 lbs. per square inch, compressed air sanding apparatus, and quick action Westinghouse brakes. One of these engines was shown at the Liege exhibition last year and attracted a great deal of attention from railway men there.

Weight of engine empty, 149,910 lbs.; water in boiler and fuel in fire box, 14,330 lbs.; weight of engine ready for the road, 164,240 lbs.;

weight on the six coupled wheels, 130,148 lbs.; weight on the truck, 44,092 lbs.; mean diameter of the boiler, 4 ft. 11½ ins.; number of tubes, Serve make, 130; length of tubes, 14 ft. 5 ins.; diameter of tubes, internal, 29/16 ins.; heating surface of tubes, 2,403 sq. ft.; heating surface of fire box, 174 sq. ft.; total heating surface, 2,577 sq. ft.; grate area, 33.4 sq. ft.; diameter of high pressure cylinders, 14 3/16 ins.;

should be ample. The greater the depth of fire box and the wider the water legs, the more rapid the circulation. This should be obtained by securing maximum depth of throat sheet and not by raising the crown sheet at the expense of the steam space.

doubtful if it is possible through natural circulation under the best possible conditions, to construct a boiler whose fire box will withstand the heat of perfect combustion, but when coal is burned in the ordinary manner the better the circulation, the less the fire box troubles. It is probable that there is a point beyond which the speed of natural circulation cannot be forced and somewhere below which is the maximum reliable capacity of the boiler, and so far as the fire box is concerned it would appear that forced circulation is very desirable if it could be made practicable.

The greater the length of fire box the greater the volume of water required to pass from the barrel of the boiler into the water legs, hence the side sheets and staybolts of a short fire box are less likely to give trouble than a long one. The tendency, therefore, should be toward a decided increase in depth of throat and width of water space and as a short a fire box as is consistent with necessary grate area. The result will be an exceedingly heavy and bulky boiler at the fire box necessitating the use of a trailer truck which it is likely will eventually have four wheels instead of two.

With reference to flues considerable observation leads me to believe that a comparatively wide bridge, say, one inch or possibly more, is desirable for large boilers, because of the greater stiffness of the flue sheet and probably better circulation between flues. But wide spacing



MINNICOGANASHENE ISLAND, GEORGIAN BAY, ONT.—REACHED BY THE GRAND TRUNK RAILWAY.

diameter of low pressure cylinders, 23¾ ins.; stroke of pistons, 25 3/16 ins.; diameter of coupled wheels, 6 ft. 13/16 in.; diameter of truck wheels, 3 ft. 1¾ ins.; engine wheel base, 27 ft. ¾ in.; length over all of engine, 38 ft. 2½ ins.; total width of engine, 9 ft. 9¼ ins.; rail gauge, 4 ft. 8¾ ins.; weight of tender empty, 37,478 lbs.; weight of water in tank, 37,478 lbs.; weight of fuel, 11,023 lbs.; weight of tender ready for the road, 85,979 lbs.; diameter of the wheels, 4 ft. ¾ in.; wheel base of tender, 10 ft. 5 15/16 ins.; length over all of tender, 20 ft.; width of tender, 9 ft. 9¼ ins.

Continuing, the speaker said:  
"Experience with smoke consumers and fuel oil has demonstrated the inability of the ordinary locomotive fire

#### Essentials in Boiler Design.

Some of the results sought for in good boiler design are reliability and economical maintenance, and also continuous development of maximum horse power efficiency. Mr. D. Van Alstyne, mechanical superintendent of the Northern Pacific, enlarged upon these essentials in a paper recently read by him before the North-West Railway Club. He considered the first of these requisites to include freedom from cracked sheets, leaky seams, leaky and broken staybolts and leaky flues. In the development of the horse power he admitted that the performance should be within the capacity and endurance of the average fireman, and that the effort toward securing efficiency should be to approach as nearly as possible that of the best stationary practice.

Reliability and low cost of maintenance depend largely on the free circulation of water around the fire box, and, consequently, the size of the passages from the barrel of the boiler to the water legs



NOT A RIVER, BUT A CHANNEL, BETWEEN ISLANDS IN THE GEORGIAN BAY, CANADA—REACHED BY THE GRAND TRUNK RAILWAY.

box to withstand the heat of perfect combustion, no doubt due to the fact that natural circulation is unable to supply the fire box with water rapidly enough to prevent overheating. It is

does not cure leaky flues, which are the most difficult boiler trouble to control. I think it can be satisfactorily shown that the rolling of a flue into a sheet is a water tight job to withstand almost any

degree of heat, provided the flue and flue sheet can be made to expand and contract together, and, therefore, that when flues leak the conditions are such as to make the flue try to expand more than

features in good care of boilers are regular and thorough washing out and blowing off, washing out and filling up with hot water, uniform boiler feeding and avoidance of working injectors as far as

ment will be much larger and heavier in proportion to the barrel than it is now.

It is quite likely that it will be necessary to carry the overhanging weight back of the drivers on a four-wheel trailer truck.

The tendency for road engines, either freight or passenger, will be to make the dead weight due to increased size of boilers a larger percentage of the total weight. This increased dead weight, however, should not be a matter of concern so long as it increases the reliability and efficiency of the boiler. The limiting capacity of the fireman is sufficient reason in itself for striving in every way to increase boiler efficiency, either through better boilers, superheating or compounding.

I think it is not overdrawing it to say that no heavy road engine should be built with weight on drivers more than 70 per cent. of the total weight, and the lower this percentage is the more reliable and efficient the engine will be, it being understood, of course, that as much of the dead weight as possible is put into the boiler."

We wish to call our readers' attention to the fact that the very popular book, "Examinations for Promotions," by W. O. Thompson, is now entirely issued with leather covers, price 75 cents, and that it will be impossible for us to supply any other kind. Please bear this in



GEORGIAN BAY SCENERY, MORE THAN 30,000 ISLANDS ON THAT SHEET OF WATER REACHED BY THE GRAND TRUNK.

the sheet and in so doing it is compressed and made smaller than the flue hole in the sheet. The length of flue, quality of water and coal, method of firing and working injectors, weather and severe service all have an influence on the leakage of flues, and this influence is, I believe, exerted chiefly through their effect on the size of the nozzle. Whatever causes, therefore, have the greatest tendency toward reducing the nozzle would be the most productive of leaky flues, and these, I believe, to be poor coal and severe service. The smaller the nozzle the more severe the blast and the greater the blow pipe action on the end of flues, making them hotter than the sheet which compresses them so that they are smaller than the sheet when they cool down. So far as my investigation goes the great majority of leaky flues are below the center line of the boiler, indicating that the short flames of highest temperature enter the lower flues. Hence the need for the greatest possible depth of fire box below the flues so that these hottest flames cannot reach them.

Any other means of keeping the intensest heat away from the flue ends will have the same good effect on flue leakage, and recent experience with a combustion chamber which sets the flue sheet 3 ft. ahead of the throat sheet has shown a marked decrease in flue leakage. Of utmost importance, however, is the care of boilers. The most poorly designed boiler is made better by more care, while the best designed boiler will not do well if neglected, and some of the important

possible when the engine is not working steam, removal of broken staybolts promptly, and intelligent expanding of flues. Water treatment has done much to reduce boiler troubles but it has its limitations and in my judgment should

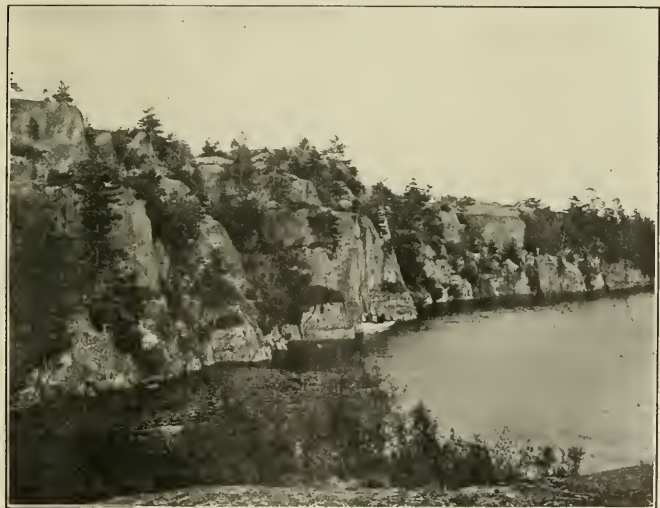

THE BLUFFS NEAR MINNICOGANASHENE, GEORGIAN BAY DISTRICT, CANADA—REACHED BY THE GRAND TRUNK RAILWAY.

not be attempted until the possibilities of design and systematic maintenance have been exhausted.

To sum up, it seems to me that the locomotive boiler in its fullest develop-

ment when sending to us for the book. It contains in small compass a large amount of information about the locomotive, and is used by many master mechanics as the basis for examinations.

# Railway and Locomotive Engineering

A Practical Journal of Railway Motive Power and Rolling Stock.

Published Monthly by

ANGUS SINCLAIR CO.,

136 Liberty Street, New York.

Telephone, 984 Cortlandt.

Cable address, "Loceng," N. Y.  
Glasgow, "Locauto."

## Business Department:

ANGUS SINCLAIR, President.  
FRED M. NELLIS, Vice-President.  
JAMES R. PATERSON, Sec'y and Treas.

## Editorial Department:

ANGUS SINCLAIR, Editor.  
GEO. S. HODGINS, } Associate Editors.  
JAMES KENNEDY, }  
J. P. KELLY, }

## Advertising Department:

Eastern Representative, S. I. CARPENTER, 170 Summer St., Boston, Mass.

## British Representative:

THE LOCOMOTIVE PUBLISHING CO., Ltd., Amen Corner, Paternoster Row, London, E. C.

## Glasgow Representative:

A. F. SINCLAIR, 15 Manor Road, Bellahouston, Glasgow.

## SUBSCRIPTION PRICE.

\$2.00 per year, \$1.00 for six months, postage paid in the United States, Canada and Mexico. For other parts of the world, \$2.50 or ten shillings. Single copies, 20 cents. Remit by Express Money Order, Draft, Post Office Order or Registered Letter. Mailing address can be changed as often as necessary—always give old and new address, and if you subscribe in a club, state who got it up. Please give prompt notice when your paper fails to reach you properly.

Entered at Post Office, New York, as Second-class mail matter.

Copyright by Angus Sinclair Co., 1906.

For Sale by Newsdealers Everywhere.

## Some Slippery Engines.

The reason why an engine with smooth driving tires moves at all on smooth rails is that there is a certain amount of friction between wheels and rails. The engine is not only capable of motion itself but it is able to draw a train of cars behind it. There was a time when men believed that a gear wheel, running in a rack, was necessary to an engine's progress, but modern practice has left the rack-rail locomotive for use on very steep incline railways.

A man standing on what schoolboys call "glare ice" is not able to pull as much of a load after him as if he were standing on a gravel walk. The reason is simply that the friction between his shoes and the ice is less than between his shoes and the gravel walk. In like manner, an engine on a greasy rail is more likely to slip than when on a good, dry rail or where sand has been liberally used. In the cases of both man and engine, the amount of friction between the surfaces which are in contact plays an important part in preventing the tendency to slip.

Experiment has demonstrated that this friction, for any particular kind of surface, is directly proportional to the weight of the man or the thing that

does the pulling. In the case of the locomotive, it has been found that on dry, clean rails the maximum friction between rail and wheel may be taken at about .25 of the weight on the drivers. That figure is called the coefficient of friction.

An engine with 100,000 lbs. on the drivers has a frictional limit of 25,000 lbs., and this is found by multiplying the weight on the drivers, called the adhesive weight, by the coefficient of friction. For that particular adhesive weight the frictional limit is fixed and unalterable, and it is not dependent on the number of driving wheels, nor on their diameter. An engine with this weight on its drivers, when standing on clean, dry rails, can exert a drawbar pull of about 25,000 lbs. In other words, that ought to be the maximum tractive power of the engine, and it is one-quarter of the weight on its drivers.

If, after calculating the tractive power of this engine by the rule involving the diameter and stroke of cylinders, mean effective pressure, and diameter of driving wheels, we should find that the tractive effort came out more than 25,000 lbs., we could reasonably conclude that the engine would be slippery, and some suitable alteration in the engine, and consequently in the factors in the formula, would be necessary. The engine would have to be so designed as to make its calculated tractive power conform very closely to its frictional limit. If the calculated tractive effort was found to be too low, the engine would, of course, not be slippery, but it would not be up to full efficiency.

That is, roughly speaking, the theory which guides the designer when considering tractive effort and weight on drivers. The number of driving wheels is a matter of distributing the adhesive weight so as not to produce excessive axle or rail loads. The diameter of driving wheels is almost entirely determined by the character of the service for which the engine is intended; large wheels are used for passenger, and smaller ones for freight engines.

We do not, of course, know definitely that the coefficient of friction remains always the same when the engine is running, and it is quite safe to assume that a moving engine will encounter stretches of track where the rails will not be in exactly the same condition as that of the clean, dry section for which we have supposed the coefficient of friction to stand.

There have been some attempts to modify the design of engines so as to make the tractive power developed when the engine is running the principal consideration, and not the starting effort, which latter is generally taken as the basis of the best practice. We

will endeavor to explain, briefly, the method of procedure adopted by the designers of the old single driver engines formerly used on the Great Western of England; also the famous 8-ft. "singles" designed by Mr. Peter Stirling, of the Great Northern, and the 7 ft. 6 in. single drivers designed by Mr. J. Ramsbottom for the London and North-Western. Two 4-2-0 or "bicycle" engines used at one time on the Philadelphia & Reading were also in the same class. The designers of these engines reasoned in some such way as this.

A passenger engine is intended to have speed; hence its large driving wheels. It is known that it will be run probably three-quarters of the time with the reverse lever notched up to give steam chest pressure for probably 25 or 30 per cent. of the stroke. The cut-off will therefore be short and the mean effective pressure in the cylinders will be less than when in full gear; under these conditions, the engine would be, for say three-quarters of the time it is in active service, running with considerably less than its maximum calculated tractive effort; it would not be slippery, but it would be constantly worked below its full tractive force.

In order to adjust matters so that better all-round results may be obtained, the principle of compromise was introduced, just as it is in a host of things where good average performance is desired rather than the extreme of accuracy. These designers, when acting with the compromise principle in view, did not take the maximum tractive effort as found with the mean effective pressure given by late cut-off. They calculated the tractive effort as it would be with the engine notched up; this was, of course, less than it normally would be in starting, and this lesser amount was made to come within the frictional limit, because the engine ran that way most of its time on the road. It is evident that with an engine thus designed, when the reverse lever is in the corner, as in making a start, the mean effective pressure is greatest and the tractive effort is the maximum. The power so applied was, therefore, somewhat greater than one-quarter of the adhesive weight, and the engine slipped more or less, for the short distance it was moving before the lever was notched up.

Every designer, of course, does not do this, but it is possible to produce the result in the way indicated. The most successful engines in general service are those which have not had the adhesive weight reduced to meet the lesser mean effective pressure in the cylinders when notched up. This is probably the reason why traction increasers have not become more gener-

ally used. The engine, as usually designed, has a reserve of power, but the engine which is somewhat slippery at the start may be fairly satisfactory for specific conditions where constant load and definite schedule form the regular conditions of the work which the design is intended to meet.

One of the functions of the traction increaser is to add to the adhesive weight at the start, but the usual way of producing an equivalent result is to sand the rails at the start, and thus raise the frictional limit. One of the objections to this practice is that it makes the train pull harder. The tendency to slip when starting, possessed by some large wheel engines, may have been introduced purposely as a compromise measure with the idea of getting better average results for the greater part of the engine's service, and after the engine has got the train under way.

Thus we see that the so-called slippery big wheel sometimes is the result of design, and does not necessarily follow from any measure of the diameter, but the tendency to slip, whether from bad design or good, old or new, is caused when the maximum tractive effort exceeds the frictional limit.

#### Trade Unions.

We have called attention in our pages from time to time to the need of a closer relationship between employer and employee, and while we do not expect to live to see the dawn of the millennium, nor shall we in this the twentieth century presume to pray for miracles, we are nevertheless assured that there is some real progress toward that brotherhood of humanity of which the poets have dreamed so long and sung so beautifully. The successful combinations of capital have had their reflex in the successful combinations of labor, and the result is gradually shaping itself into a livelier feeling of mutual respect. The safeguarding of capital may loom larger in the world's eyes than the safeguarding of trades unionism, but the latter is the nobler of the two, and has heroically and successfully fought its way to a secure vantage ground, and it has now to be dealt with in all industrial undertakings.

Among the men employed on railways, the Brotherhood of Locomotive Engineers was among the foremost, if not actually the first organized body of skilled workmen whose mutual confidence in each other, and whose continued fidelity to the principles of union has gradually brought the organization to a degree of stability and importance that has never been surpassed. What we say of the premier organization applies with equal force to the Brotherhood of

Locomotive Firemen. The strength of these unions is an object lesson to other societies. They teach self-respect and self-reliance, and differ from other trades unions in the fact that they have never condescended to become the cat's-paw of designing politicians, nor have any of the members used the brotherhoods as a means to political preferment.

Singleness of purpose in trade unionism is its saving feature. Nothing need ever be hoped for, as springing from the action of either of the two great political parties, which might be looked upon as calculated to improve the condition of the working classes. Successful politicians in America are not in sympathy with the lowly toiler. As a rule, such men are owned absolutely by wealthy corporate interests, and, with a blindness singularly fatal to their own interests, workmen will not vote to elect a man of their own order to office. Workmen are too easily led by rising, pretentious legal luminaries who scoff at the deluded workers behind their backs.

The recent British elections have perhaps shown the first signs of a new departure in representative government. There are now about thirty workmen in the Parliament of the United Kingdom, and their conduct will be watched with interest, and it is to be hoped that all will see realized the words of Mr. George N. Barnes, the accomplished secretary of the Amalgamated Society of Engineers, who was recently elected to Parliament. Speaking of the new members, he said that "their influence will be such as to lessen the bitterness of industrial life and strife, to raise labor in its own estimation, and give it a better share in the good things of life not only without detriment to any one else but with positive advantage to all concerned." Here is a programme for the practical advancement of the workman which might well be imitated in other lands.

#### Sanitation of Passenger Cars.

A rather interesting statement is credited to Dr. H. M. Bracken, of St. Paul, in the account given of a meeting of the American Public Health Association, held at Boston. Dr. Bracken believes that the proper sanitation of railway coaches can be obtained by intelligent construction and constant and thorough care.

In his experience, however, he has found ignorance and indifference in the matter of sanitation to be frequently manifested by railway surgeons, while intelligence is generally shown by the heads of the mechanical departments of railways.

In this, as in other matters, it appears to us that history seems to re-

peat itself. Gunpowder was not discovered by a military man, nor the telescope by an astronomer, and so it is that those whose life work is concerned with the promotion of sanitation in all its forms, have been found to be dependent upon the efforts of those in whose calling sanitary science is an incident rather than an object.

Among the possible reforms indicated at this meeting was the one that porters should not be allowed to brush passengers clothing in the cars, as, by so doing, the dust was simply removed from one object and deposited on another, and the atmosphere was vitiated in the process. Dr. Bracken suggests that dusting should be done with a damp cloth. Plush and velvet upholstery should give way to leather or open cane seats, and facility for easy and thorough cleaning should be a prominent feature of all passenger car construction. This has been done in very many instances, and there is a growing desire to secure elegance of design, combined with the greatest utility. The union of the two is possible and always beneficial.

One of the primary requirements, in all public places as well as in railway cars, is the prohibition of promiscuous spitting. Investigation has shown that tobacco users are by no means the worst offenders in this respect, and it is suggested that cuspidors should be liberally provided and notices advising their use should be posted in the cars. We would like here to observe that the notice usually seen regarding spitting almost invariably winds up with the statement that some heavy legal penalty may be imposed upon the convicted spitter.

The avoidance of a fine or imprisonment does not appeal to a great many people as a good reason for refraining from the objectionable practice. As a matter of fact, there are exceedingly few prosecutions for spitting and the records show still less where the legal penalty has been imposed. It is right and proper to have the strong arm of the law on the side of health and good behavior, but it seems to us that if notices were conspicuously displayed setting forth the desirability and the reasons for this sanitary observance, the appeal would be far stronger than where the practically unenforced penalty of the law alone confronts the offender. Notices containing the direct and personal appeal so often found in good advertisements would be likely to produce results, and the educational value of a few well chosen words would be of the highest. The average man can be made to respond where good, plain common sense backs up his acceptance of a rule, especially if it calls attention to the where and how of its observance. "Thou shalt not" comes from a time when blind obedience was exacted under penalty

rather than as now, when intelligent cooperation is rightly insisted upon as a duty.

#### Change in Per Diem Charge.

A revision of some of the per diem rules of freight car interchange was recently made by the American Railway Association, the form of procedure being to submit the proposed amendments to a letter ballot. Per diem rule No. 1 has been altered so that the daily rental for the use of foreign cars on any road has been increased from 20 to 25 cents per day. The penalty rate, contained in rule No. 3, has been reduced from 80 to 75 cents per day. This penalty charge is made in addition to per diem rate and is levied on railroad companies failing to unload cars within the prescribed time.

There was also another amendment to per diem rule No. 3 which read that if a car is held by a road, the aggregate mileage of which is 2,000 miles or over, the penalty rate shall commence twenty days after the date of such notice. This amendment, although it received the approval of a numerical majority, was, nevertheless, rejected, as under the by-laws of the association it is necessary for any amendment to receive such a majority as will carry with it the representation of the preponderance of the cars owned. The membership of the association is 304, and the cars owned or controlled by members amount to 1,874,100. The majority requisite for approval in this case was 153, and that number would have represented the control of 1,240,400 cars. The use of form N, penalty notice, was approved by the association. These changes take effect July 1, 1906.

#### San Francisco.

The appalling calamity that has fallen upon the city of San Francisco casts the gloom of sorrow over the entire country, and the generous outburst of ready sympathy manifested by the American nation is another fine proof of how closely knit together the people are in the bonds of common fellowship. While the cloud of misfortune was dark beyond a parallel in modern times, the star of hope, brightened by the tender hand of sweet charity and willing helpfulness, shone out full of promise for the distressed.

The call of the stricken city for tents, bedding and bread was responded to with a degree of alacrity that would have been impossible in any other age. The electric telegraph had no sooner thrilled the world with the terrible story of the earthquake's ruin than the wheels of a thousand locomotives were hastening to the relief of the homeless people. The noble engine was never put to a grander use, and it is a matter

of pride and satisfaction to feel and know that man's ingenuity in harnessing the forces of nature, as exemplified in the steam engine, was so swiftly used in alleviating the sufferings incident to the most terrible disaster that has, in many centuries, fallen to the lot of a magnificent city.

#### Notices in Railway Cars.

The new "tube" railway, as they call their underground means of travel in London, runs from the Waterloo station to Baker street, the latter being the one on which Sherlock Holmes is supposed to live. This new "tube" is generally spoken of as the "Bakerloo," and the London Chronicle calls attention to a curious notice to passengers which, at least a short time ago, was to be seen in the coaches.

Most railway by-laws are couched in language painfully obscure, but there is no obscurity about the rules which govern the new "Bakerloo." One of these reads: "No person shall wilfully, wantonly or maliciously break, cut, scratch, tear, soil, deface, damage, or remove any carriage using the railway." That particularly covers every frame of mind in which any passenger might be tempted to do anything whatever detrimental of the company's property, says the Chronicle. If there is a fault about the language it is that of superabundance. One has heard of coaches and trucks being lost on ordinary railways, but the person who can quietly remove a carriage from a "tube" and apply it to his own purposes surely deserves to be allowed to keep it.

#### Locomotive Trials.

Some comprehensive experiments have recently been carried out on the line from Breslau to Sommerfeld, in Germany, with a new type of locomotive express engine, designed by Mr. Garbe, of Berlin, using strongly superheated steam, for which purpose a special system of tubular apparatus is made use of. The boilers are larger than the present ones, the driving wheels have a diameter of 6.88 ft., and the cylinder is 21.64 ins. in diameter. With a train of 36 axles a speed of 68.34 miles per hour was readily attained, and in places at the rate of 72 miles. These experiments, which were witnessed by a representative of the government and by many engineering experts, have evoked much interest in railway circles.

#### Book Notices.

**Eminent Engineers.** By Dwight Goddard. Published by the Derry-Collard Company, New York, 1906. Price, \$1.50.

This is a reference work of 280 pages,

and contains brief, interesting biographies of thirty-two eminent inventors and engineers who did much to further the progress of the mechanical arts. The author in his selection of names has endeavored to include men of action in the busy world, those who accomplished something of importance in the development and application of power and machinery. The table of contents shows the names of sixteen noted Americans and also sixteen British and continental workers in the same great field.

Mr. Goddard has spent a large amount of time in the selection of the engineers to be represented, as well as the matter concerning them. Unimportant details have been omitted, and only the facts of general interest have been given. Many of the portraits used as illustrations are rare and were obtained from interesting sources, all of which goes to make the book of value to every one who is at all interested in the progress of mechanics. The book is well printed on good paper and bound in a very substantial manner. We are very sure it will prove interesting to our readers.

**Valve Gears for Steam Engines.** By Cecil H. Peabody. Second edition, revised. Published by John Wiley & Sons, New York, 1906. Price, \$2.50.

This book contains 142 pages, with index, and has thirty-two plate engravings inserted at the back, printed and bound in such a way that any plate can be got at by the reader and held so that it can be seen at a glance, without the necessity of turning over the pages of the book. The author is professor of naval architecture and marine engineering in the Massachusetts Institute of Technology, and he tells us that his book is intended to give instruction to engineering students on the theory and practice of designing valve gears for steam engines.

Graphic methods are used throughout the book, both for demonstration of principles and for design, but in the appendix the analytical method is followed. In dealing with radial valve gears, of which the Walschaert is an example, the underlying principles of such gears are pointed out, and several forms are illustrated.

The book has six chapters, an appendix, and a good alphabetical index. The first chapter deals with the plain slide valve; the second, with shifting eccentrics; the third, with link motions; the fourth, with radial valve gears; the fifth, with double valve gears; and the sixth, with drop cut-off valve gears. The author is careful to say that while his work is intended as a valuable assistance to the student of this important subject, facility of design is to be obtained through experience only.



**Electric Locomotive, N. Y., N. H. & H.**

The New York, New Haven & Hartford Railroad contemplate the electrical operation of their main line between New York City and Stamford, Conn., a distance of over 33 miles. That portion of the road which lies between the Grand Central Station and Woodlawn, N. Y., uses the tracks of the New York Central and is a portion of the electrical zone of that company within which the direct-current third-rail system is being installed. Between Woodlawn and Stamford the road is being equipped with the Westinghouse single phase, alternating current system, and the trains will be operated by electric locomotives which take alternating current from the overhead trolley line. The power station of the New Haven Company will be located at Riverside, Conn., three miles from Stamford. The overhead construction will be supported from steel bridges placed every 300 ft., and which will normally span from four to six tracks, though on certain portions of the road longer bridges will be employed. Every two miles the bridges will be made of a specially heavy construction, forming an anchor bridge to make the overhead structure even more secure. The trolley wires will be hung from steel messenger cables which, in turn, will be supported by heavy insulators mounted upon the steel bridges.

Thirty-five locomotives are to be furnished by the Westinghouse Company, suitable for operation on the direct current division between the Grand Central Station and Woodlawn, and on the alternating current portion of the line between Woodlawn and Stamford. One locomotive has already been constructed and the results have been satisfactory. The frame, trucks, and cab of the locomotive were built at the Baldwin Locomotive Works, according to designs developed with the co-operation of the New Haven Railroad and the Westinghouse Electric & Mfg. Companies.

The frame of the locomotive is of the rigid type with side pieces made of steel channels, to which are bolted and riveted other steel channels placed transversely, two over each truck, forming transoms for the transmission of the weight to the center plates. These channels practically form what would be body bolsters for a car. The frame is still further strengthened and secured by diagonal plate braces. As the entire space between the wheels is occupied by the motors, it was impossible to transmit the drawbar pull through the center line of the locomotive; so the entire strain is carried by the strong plate girders which make up the locomotive frame. A Westinghouse friction draft gear is mounted directly underneath the box girder at each end and is applied to two steel bumpers laid horizontally between

vertical gusset plates on the ends of the side channels.

The running gear consists of two trucks, each mounted on four 62-in. driving wheels. The trucks have side frames of forged steel to which are bolted and riveted pressed steel bolsters which carry the center plates. A very strong construction is secured without excessive weight by the use of bolsters 30 ins. wide at the center plate and extended to nearly double that width at the ends which are bolted to the side frames. Center pins 18 ins. in diameter transmit the tractive effort to the frame. They are well lubricated to permit free motion on curves. The distance between truck centers is 14 ft. 6 ins.

The cab is formed of sheet steel

collect alternating current from the high potential overhead trolley line, the locomotive is equipped with two pantograph type, bow trolleys, shown in our illustration of the N. Y., N. H. & H. locomotive. Each of these has a capacity sufficient to carry the total current required by the locomotive under average conditions. Two are provided to insure reserve capacity.

With controllers as ordinarily made, it is usual railway practice to pass from the series to the multiple position without an efficient intermediate running speed. With the New Haven equipments, however, the type of motor used permits an almost indefinite shunting of the field without impairment of commutation or operation, and higher speeds are pro-

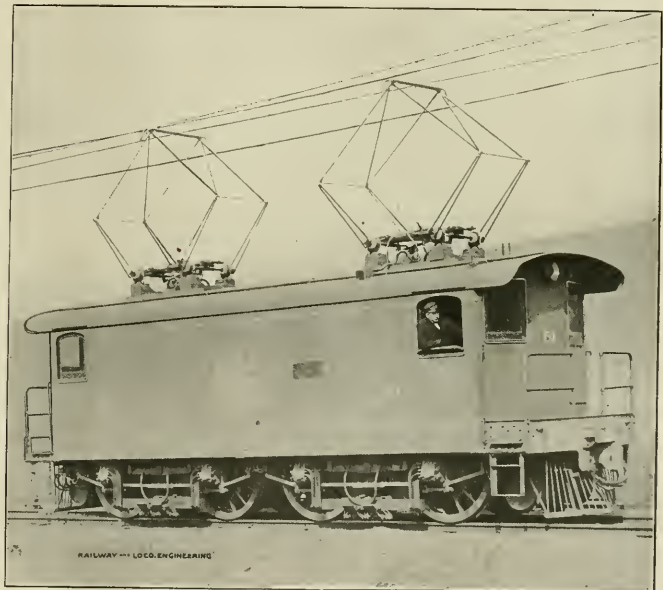

NEW YORK, NEW HAVEN & HARTFORD ELECTRIC LOCOMOTIVE.

mounted on a framework of Z-bars which supports the walls and roof. Windows are provided at each end, giving an outlook on both sides and in front of the locomotive; and the driver is so close to the front that he can see the track a very few feet ahead.

On the direct current part of the line current is taken from the third rail system by eight collecting shoes, four on each side of the locomotive, arranged in pairs of two each. There are two pairs on each side, one at each end, for the purpose of bridging such gaps as may occur in the third rail system. The direct current contact shoes are designed to work on two forms of third rail, one in which the shoe runs under the rail, and the other on top of the rail. To

vided by shunting the fields before passing into multiple. In this way several efficient running points are obtained between the series and multiple positions of the controller handle.

The auxiliary equipment includes a steam generator to supply heat to the railway coaches in cold weather; a complete air brake equipment, signal apparatus, automatic bell ringers, whistles, sanding apparatus, etc.

The New Haven locomotive measures 36 ft. 4 ins. over the bumpers and weighs, approximately, 85 tons. It is capable of handling a 200 ton train in local service on a schedule speed of 26 miles per hour, with stops averaging about 2 miles apart—making in such service, a maximum speed of about 45

miles per hour. It can also handle a 250 ton train on through service with a maximum speed of about 60 miles per hour. With heavier trains it is planned to couple two or more locomotives together and operate them in multiple.

#### Carrying a Tool to the Work.

There is an old saying that if the mountain will not come to Mahomet, then Mahomet must go to the mountain, and a modern parallel to this may be found in the

volts can be used. There is also a small amount of field resistance which gives a considerable range of speed. This may not be a particularly economical way of utilizing electrical power, but the reduction in the time lost between the erecting shop and machine shop in calipering holes for bolts is so great that the total cost of turning bolts has been reduced about 40 per cent.

There is a combined clutch and brake provided with the handle, convenient to the operator, so that when the clutch is thrown out, the brake is applied, stop-

of sidings. The capital amounted to \$1,247,670,000; there were 25,288,723 passengers carried, and the freight traffic amounted to 50,893,957 tons. The close of the last fiscal year witnessed the completion of 793 miles of electric railway, and there were 203,467,317 passengers and 510,350 tons of freight carried on these electric roads.

#### Simple, Modest Door Closer.

When you open a door which has on it one of those pneumatic door closing devices, you really do more than simply open the door. As you push it ajar and shove it back to its full extent, you have really expended enough energy not only to open it wide but to close it as well, and at the same time to overcome all the internal friction of the device itself which is developed in both movements. Further than this, some of the devices compel you to give up, in the one operation of going through, enough energy to permit the door closer to do some fancy work with the stored up energy.

Have you not sometimes pushed a door open against the heavy resistance of the automatic closer, only to find that the door swept back through all but about two inches of its stroke at full speed, and then slowed down, stopped, hesitated, and then noiselessly sneaked shut without even clicking the latch? All this takes energy, and you, gentle reader, are the energy-supplier for the fancy stunt door closer.

Our illustration, taken from the pages of the Blacksmith and Wheelwright, shows an easily made gate or swing door closer which does not stall a robust man on the threshold. It consists of two pieces of round iron twisted about each other twice, with the ends flattened so as to be screwed to the door or gate and the door post.

The operation of opening causes the worm to turn (if you will



GRAVITY CLOSING DOOR HINGE.

allow the expression), and the door is slightly raised in consequence. You will hardly notice the work you are thus doing, because you are at the long end of a lever, and this device has nothing up its sleeve. The weight of the door acting on the spiral hinge swings the door shut again, and there you are, or rather there the door is, and when the thing is worn out it is cheap enough to replace without your having to sell out all you have at a loss.

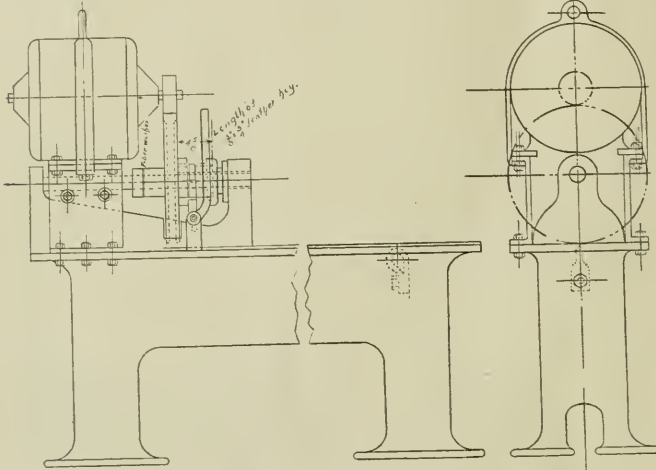

PORTABLE, ELECTRICALLY DRIVEN BOLT LATHE.

reversal of the usual method of bringing work to a machine by the bringing of a machine to the work. Among the many interesting things which are to be seen in the Columbus (Ohio) shops of the Pennsylvania Lines is an unpretentious lathe which is capable of being moved from place to place as occasion requires, and it always does business in the vicinity of the engine to be served.

This forms a very good example of the effect which may be, and has been, produced in many modern railway repair plants by the advent of electricity as the form in which power can be very satisfactorily used. Electricity in the shop has made this simple but effective arrangement possible, and Mr. W. S. Miller, the master mechanic in charge, has not been slow to appreciate the possibilities which the separate electric drive offers. This example, as one of many that might be given, is selected as a typical case, and we are indebted to Mr. D. F. Crawford, general superintendent of motive power for lines west, for the information.

Our illustration shows the application of a small motor to an ordinary 16 in. Putnam lathe. The switchboard is not shown, but the arrangement of the switches is such that either 120 or 240

ping the lathe spindle, but allowing the motor to run. The lathe is provided with two hooks by which it can be picked up by one of the overhead cranes in the erecting shop and placed at whichever engine requires bolts to be fitted. The necessary number of plugs are provided so that the electric cable may be attached by simply pushing the connection on the end, into a device somewhat similar to an automobile receptacle. A similar arrangement is provided on the lathe. The speed range is not sufficient to suit the possible range of work indicated by the entire swing of the lathe, but inasmuch as the bolts turned run only from  $\frac{3}{4}$  to 2 ins., the results are said by the company's officials to have been entirely satisfactory.

#### Canadian Railways.

According to the Toronto Globe, Canada possessed in 1861 but 1,880 miles of railways, with a capital of \$38,280,000. These lines carried 1,825,000 passengers, handled 1,459,446 tons of freight, and earned a net sum of \$1,050,000, the aggregate being \$6,725,000. On June 30 last there were 20,601 miles of completed railways in the Dominion, besides 3,632 miles

# Our Correspondence School.

In this department we propose giving the information that will enable trainmen to pass the examinations they are subjected to before being promoted. If any of our students fail to understand any part of the instructions, we will gladly try to make them plainer if they write to us. All letters intended for Our Correspondence School ought to be addressed to Department E.

## Value of Reading.

Herschell, the eminent astronomer, who was accustomed to make use of accurate knowledge, said: "Were I to pray for a taste which should stand me in good stead under every variety of circumstances and be a source of happiness and cheerfulness to me during life, it would be a taste for reading." He spoke wisely, and had he lived in our day, he would have seen how easily the desire for reading can be gratified, how the garnered wisdom of the ages, as crystallized in the printed page, is within the reach of the humblest. He also would have seen the growing necessity for reading in order that one may not only keep abreast of the times, but also continue to be instructed in the new and complex changes that occur in every department of human endeavor. In no sphere of industrial activity is this more true than in that of railroading. Our correspondence school aims at keeping our readers instructed in all that is new in construction, as well as all that is put to new uses. In the lesson this month we present in brief form the details of the lubricator and its attachments with the assurance that the questions and answers will receive the careful attention of our readers.

## Second Series of Questions.

61. Describe the manner in which a sight feed lubricator operates.

A.—Sight feed lubricators operate on the hydrostatic principle. In other words, the lubricator depends on the action of natural laws which have to be complied with or failure is the result. The positive steam pressure in the lubricator and pipes being the same as the back pressure, these soon neutralize each other and this leaves the positive pressure of the column of water extending through the pipe leading from the condenser, the condenser itself, and the part of the pipe above it; against this is opposed the back pressure of the column of water in the sight feed glass. As the latter is much less than the positive pressure, the drops of oil are forced through the nozzle.

62. How should a lubricator be shut off before filling?

A.—The feed valves should be shut off first, the water valves next and the steam valves last.

63. Will any bad results ensue from filling a lubricator full with cold oil?

A.—Yes; if the lubricator is not provided with an expansion chamber. Oil

expands about  $\frac{1}{2}$  in volume while being heated, from about 70 degrees to the temperature of steam at 200 lbs. pressure, which is 387.7 degrees F.

64. Which is the better practice, to close the feed valves or water valve while waiting on sidings, etc.?

A.—The better practice is to close the water valve instead of the regulating valve while waiting on side tracks, or while waiting for orders. By so doing the hydrostatic pressure is cut off from the body of the lubricator and the pressure within the body of the lubricator equalizes with that in the feed glass chamber. Then, by opening the water valve, the feeds will start off at the same number of drops per minute as originally, as the adjustment has not been interfered with. It is not generally understood that if it becomes necessary to do any switching or if the engineer wishes for any reason to feed less oil, he can slow down the number of drops per minute by simply throttling the water valve. This will give the same effect as adjusting the feeds to a slower rate. The only objection that can be made to closing the water valve in these cases is that the air pump does not receive oil while the water valve is thus closed.

65. In what order should valves on lubricator be opened?

A.—First, the steam valve. Next, the water valve. Last, the regulating stems. Under no circumstances should the water valve be opened first.

66. Does the draft from the open cab window affect the working of the lubricators? Why?

A.—It did with the old tubular glass type of lubricator. The draft blowing on the lower feed arm congealed the oil to such an extent that it affected the rate of feed, but with the newer type of lubricator, such as the Detroit No. 21, the feed chamber is within the body, and the feeds are not affected by any drafts or change of temperature.

67. What else might cause irregularity of the feed?

A.—There are three conditions. First, if the engineer should throttle the steam to the lubricator down to that point where it becomes wire-drawn, the combined steam chest pressures would overcome the lubricator pressure and the feed would slow down. Second, if sediment should gather in the water passage to such an extent that the openings would be closed up, this condition would be similar to throttling the water valve and would reduce the number of

drops per minute. Third, when the opening through the small choke in the automatic steam chest plug becomes enlarged beyond  $\frac{7}{64}$  in. the rate of feed will vary. The same will happen when the opening through the chokes at the lubricator end of the oil pipe in some types of lubricators becomes enlarged.

68. If the lubricator feeds faster when the throttle is closed than open, where is the trouble?

A.—In the chokes. [In this connection the reader is referred to some remarks on automatic steam chest plugs and valves which are to be found on page 12 of the pamphlet issued by the Detroit Lubricator Company, Hodges Building, Detroit, Mich., a copy of which may be obtained by direct application to the company.—Ed.]

69. If the sight feeds get stopped up, how should they be cleaned?

A.—This question has reference to lubricators while in service filled or partly filled with oil. Cleaning can be accomplished by either of the following methods: First, open the feed regulating valve wide to the feed in question and open the sight feed drain stem. The result will be a lessened pressure in the sight feed chamber which will force the clogging matter out of the cone. If the obstruction is too great to be forced out in this way try closing the other regulating feed stems and also the water valve. Open the drain valve to the body of the lubricator. This will allow the pressure to escape through the body of the lubricator and at the same time the steam pressure will blow down through the feed cone and will dislodge the obstruction and force it into the body of the lubricator.

70. How should the choke plugs be cleaned?

A.—Take them out and examine them. Run a small wire through the opening. They should be renewed when the opening is  $\frac{7}{64}$  in. in diameter.

71. Can you explain the use of the equalizing pipe?

A.—The main object of the equalizing tubes is to overcome the back pressure from the steam chest. At the same time it furnishes condensation to the sight feed chambers. By the use of these tubes the same pressure exists on top of the water in the sight feed chamber as on the surface of the water in the condenser and this steadies the feed.

72. What will be the effect if an equalizing pipe were broken off or became very loose?

A.—This has no application to the No. 21 Detroit lubricator bulleye type, as the equalizing tubes are drilled through the metal. In the old style of lubricators, the water of condensation would escape in case the equalizing tubes were broken or became very loose.

73. How can it be known whether the equalizing tubes are stopped up?

A.—When it occurs in certain types of lubricators the feeds become unbalanced. It cannot happen to Detroit No. 21 lubricators.

74. Can you explain why, when engine is being worked slowly, with full throttle, the valves become dry and the lever jumps when the lubricator is apparently feeding properly?

A.—There are several reasons, especially with lubricators having the chokes at the lubricator end of the tallow pipe. There may be traps in the tallow pipes in which the oil will accumulate to a greater or less extent, instead of going to the cylinders. The tallow pipes should always have a gradual descent from the lubricator to the steam chest. Another cause is that too small a steam pipe is used to connect the boiler with the lubricator, or steam may be taken from a fountain which has not a large enough connection with the boiler to supply all the demands made on it. Then, again, the lubricator may be properly installed and the engineer may cause this trouble by throttling the steam to the lubricator.

75. What would you do under these circumstances?

A.—Supply the correct conditions.

76. How many drops in a pint of valve oil fed through a lubricator?

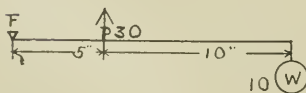
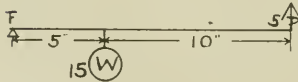

A.—It is impossible to state any absolutely definite number of drops in a pint of valve oil. There are so many conditions which affect the number, such as the density of the oil, the temperature of the oil, the rate of feed, viscosity of oil, size of nozzle, etc. Tests have been made which indicate that there are in the neighborhood of 6,000 drops in a pint

of oil; others give 6,600 drops, and this may be taken as a fair basis for answering the following questions.

77. Assuming that five drops per minute are fed to each of two valves and a drop per minute to the pump, how many hours would be required to feed a pint of valve oil?

A.—There would be eleven drops per

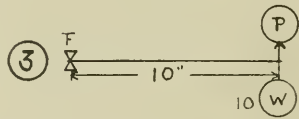
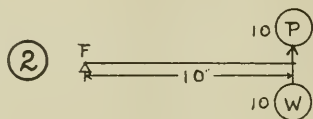
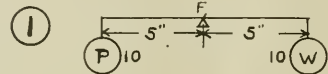

minute leaving the lubricator under these conditions, and assuming that there are 6,600 drops in a pint of oil, the pint of oil would last for 600 minutes, or 10 hours.

78. Assuming that the engine is run 20 miles per hour, how many miles per point would be run?

A.—If a pint of oil lasts 10 hours and an engine runs 20 miles per hour steadily it will be able to run 200 miles on the pint of oil.

79. How many drops per minute should ordinarily be used?

A.—This depends on the style of engine and the character of the service being performed and may differ on different roads.

Calculations for Railway Men.

BY FRED H. COLVIN.

Before going any further with these problems it will be well to go back to the foundation of all things mechanical, the "lever."

While the wheel and the screw and the wedge are also supposed to be at the bottom of things, the wheel is really a continuous lever, as we shall see later, and the wedge does not apply in railroad work nearly as much as in machines for metal working and similar uses. Car replacers may be called an application of the wedge, but it is a case where the wedge remains stationary and the load moves itself up on it. Then there are driving box and other wedges, but these are for adjustment and not a means of applying power.

The most familiar form of lever is

probably the crowbar, but we also have the reverse lever, throttle lever, equalizing lever, whistle lever, and no end of them, in addition to the driving wheel itself, which we will look into a little later, to say nothing of the question of brake leverage, which is always with us. Then, too, I hope to show a short cut in the question of lever figuring which does not seem to be generally known, although it is not new or original.

Lever are divided into three classes as follows:

First—Where fulcrum is between the load or weight and the power.

Second—Where weight or load is between the fulcrum and the power.

Third—Where power is between the fulcrum and the weight or load.

These are shown in the diagrams which accompany this article, the top row being first class, next row second class and bottom row third class, as marked at the left.

The fulcrum is the point where the lever bears on its pivot and is shown by the small triangles and marked *F*. Power, or force applied, is marked *P*, and the load or weight *W*. The distances are shown in inches so as to get something we can figure on and the weights and power or force are indicated in pounds by the figures shown.

A crowbar is a lever of the first class, a reverse lever is of the second class, and a ball and weight safety valve is of the third class, if we consider the steam as the force or power, and this comes pretty close to being the facts of the case.

Beginning at the left, in the levers of the first class we find a very simple case,

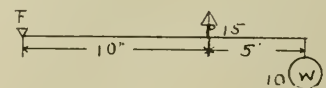
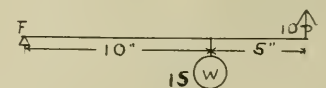
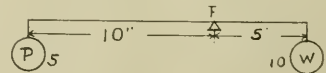

where there are 5 lbs. on each side of the fulcrum and it is very clear that a 10 lb. weight on each end will just balance. In other words, a force of 10 lbs. will hold up a weight of 10 lbs. at the other end.

Taking the next figure, we find the force *P* at the same distance from the fulcrum, but the weight moved to a dis-

tance of 10 ins. It is then very clear that the 10 lb. force will only support 5 lbs. at  $W$  because it is working at a disadvantage. Or, as some say, the "load arm" is twice the length of the "power arm," and it will take twice the force to support it. The third figure shows this reversed and the advantage on the side of the "power arm," so that 5 lbs. will support a weight of 10 lbs. at the other end.

So far, this has been very plain, and, perhaps, a little prosy, but when we come to levers of the second and third class it is a little different and it is also more interesting when we can apply these principles to things that we handle every day on the road or in the shop. This will have to come later.

All of these can be studied out by careful thinking and taking care not to get mixed, but it is much easier if we fix the little rule or law which governs all levers, firmly in our minds. Then we never run into a snag and can always tackle anything in the way of levers with certainty.

It has been found that if we multiply the length of the "power arm" by the power applied and divide this by the length of the "weight arm" or "load arm," we have the weight that can be supported. The only thing to be careful about is to be sure and get the correct arms in each case, and to help this we call the fulcrum  $F$ , the power  $P$ , and the weight  $W$ .

Then as the length of the power arm multiplied by the power applied must always equal the length of the weight arm multiplied by the weight lifted, or supported, we can always find out very easily just what we want to know.

In the first figure we have  $P \times F$ , or simply  $P F = F W$ , which in figures gives  $10 \times 5 = 5 \times 10$ , or 50 in both cases. Applying this to case three, and we have  $5 \times 10 = 5 \times 10$ , or we can say power arm times power equals 50, and this divided by weight arm, or 5, equals 10, as the weight that can be supported.

The first case of the second class shows the weight and power both applied at the same point, but in opposite directions, and it is, of course, evident that they must be equal. The next case, however, is a little more puzzling, and here is where we might make a mistake about the proper or real length of the power arm.

But the rule helps us out, and we say  $F W = F P$ , or  $5 \times 15 = 75$ , and as the length of the power arm is  $F P$ , or the whole 15 ins., we divide 75 by 15 and find that 5 lbs. will support the load in this case. Shifting the weight to the point shown in the next figure, the last of the second class examples, we have  $F W = 10 \times 15$ , or 150, and dividing this by  $F P$ , or 15, we have 10 as the force necessary to support the load of 15 lbs. applied, as

shown. In levers of this class the power arm always has the advantage of being longer than the weight arm. Coming to the third class, we have the same condition for the first figure as in the second class of levers, but get down to business in the second example. In this class the power arm is always at a disadvantage, as will be seen.

The weight arm is always  $F W$ , and in this case  $15 \times 10$ , or 150, while the power arm is only 5, so we divide 150 by 5 and get 30 lbs. as the force required in this case. In other words, the power is at such a disadvantage that the power must be three times the weight supported.

In the next and last example we move the power arm out to a point 10 ins. from the fulcrum and then have the same weight conditions as before, but a power arm 10 ins. long instead of 5, so we divide 150 by 10 and get 15 lbs. as the force required. This is just half that required in the last example, and we see the advantage of keeping the power arm as long as we can, but there are limiting conditions that we will come to later.

## Questions Answered

### POSITION OF WAY CARS.

(39) Loco Engineer, Vancouver, B. C., writes:

1. Please let me have your opinion as to where would be the best place to put way cars in a train when handling trains over a hilly division. A.—If you put way cars at the front of the train it is perhaps more convenient for the engine and crew, in case they have to be set out on a side track. When they are put at the back of train it is more convenient for the conductor, as it lets the train pull farther ahead and brings him and the station agent together without his having to walk the whole length of the train. The hilly division does not make much difference, because all stations are not in hollows, and all are not on high points.

2. Where are way cars usually placed on the general run of roads? A.—They are usually placed at the rear, end of trains.

### OVER-PORT IN RICHMOND VALVE.

(40) Turcotte, Montreal, writes:

Regarding the low pressure slide valve of the Richmond Crossover Compound, I maintain that the slide valve doubles the port opening release, by the port around the valve. Other people say I am wrong; they hold that it only doubles the port at admission, and it has been left for you to decide. A.—The valve used on the Richmond compound is a modified Allen valve, and its modification by the designer, who called it a

"double ported" valve, was to do what the ordinary Allen valve did not do. The valve port, or over port, in the Richmond valve is used as an exhaust as well as an admission passage. The time when the opening for the exhaust needs to be most efficient is at the beginning of the exhaust period. The auxiliary valve port acts as an exhaust port only during the first portion of the exhaust period. When the main exhaust passage becomes sufficiently open, the supplemental passage closes, and it afterwards becomes temporarily an admission passage.

### DOUBLE SHOE OR CLASP BRAKE.

(41) C. B. C., Harrisburg, Pa., writes:

I notice that the Pennsylvania Railroad Company have some eight wheel passenger cars in service, with two brake shoes acting against each wheel; or, in other words, two brake beams acting against each pair of wheels. Now, it seems to me that if each shoe is exerting a force of 45 per cent. of the weight on the rail, under the wheel, against the wheel, that such a wheel would not be very hard to slide, owing to the greater area of contact between shoe and wheel. As I have never seen anything in print in regard to this type of brake, I would like to learn from you as to why it is done, what advantage is gained, and whether it is good practice. A.—The kind of brake you refer to is usually called the "clasp" brake; and it was thought that this type of brake would hold better with less brake shoe heating and, consequently, less brake shoe wear, because of the greater area of brake shoe surface in contact with the surface of the wheel tire. The clasp brake holds a little more than the ordinary type, but without much less, if any, brake shoe wear, and has a greater tendency to slide wheels than the standard construction. Complications in foundation brake design more than offset any advantages the clasp brake may have when used on light cars having four wheeled trucks; and for this reason it is not considered good practice to employ this type of brake. It is our impression that the road you speak of as using it is abandoning it.

### VALVE OPENING AND LEAD.

(42) G. H. P., Willow Glen, N. Y., asks:

If an engine has lead and you place her on the forward center, lever on center of quadrant, do you cover front port? I claim that as you pull the reverse lever up you keep opening the port wider. Can you cover the port in this position? A.—With the crank pin on the forward center and reverse lever in the extreme forward notch, the valve is open the amount of the lead. As you pull the lever up to the center of the quadrant

you keep opening the port. As you carry the reverse lever back from the center to the extreme back gear notch you cause the valve to move back again until it comes to the same position it did when in extreme forward gear; that is, open just the amount of the lead. You cannot close the valve with engine in this position by any movement of the reverse lever.

#### WEIGHT FOR SAFETY VALVE.

(43) A. J. Jennings, La., says:

In a recent examination I had two problems put before me, on which I failed. Please answer through the question columns of RAILWAY AND LOCOMOTIVE ENGINEERING. One problem was, What amount of weight is required to hold down 100 lbs. pressure of steam on the end of an 18 in. lever, the diameter of the valve being  $2\frac{1}{2}$  ins.? A.—You have not stated the distance between the center of the valve and the fulcrum end of the lever. We will assume it to be 3 ins., and proceed with the question. First, find the area of the valve by multiplying its diameter by itself and then by .7854; this gives 4.9 sq. ins. The pressure of steam on this surface is 490 lbs. Now, take the weight of the valve, say, 3 lbs., and subtract it from the upward pressure against the valve; that leaves 487 lbs. Next, take the weight of the lever; suppose it to be 4 lbs.; find its center of gravity by suspending it by a string about the point at which it will exactly balance. We will suppose that you find it is 9 ins. from the fulcrum. The whole weight of this lever may be considered as acting at the center of gravity. Then 4 lbs. multiplied by 9 and divided by 3 gives 12 lbs., which is the amount which the weight of the lever will balance; 12 from 487 leaves 475 yet to be balanced. We now have a lever with the weight hanging on it equivalent to 475 lbs., the arm of the weight 3 ins., and the arm of the power 18 ins.; the problem becomes  $475 \times 3$  and divided by 18 gives 79½ lbs., which is the amount which must be hung on the end of the lever. Read calculations for railway men in our correspondence school pages in this issue. Your other question will be answered later.

#### HIGH SPEED BRAKE BREAKS SHOES.

(44) W. L., Galveston, Tex., writes: We are using the high speed brake in connection with the American slack adjuster. I find I am having considerable trouble with the brake shoes breaking, which I am convinced is due to the increased braking power while running in taking up the slack and causing too little shoe clearance and, of course, the train to drag. This refers to passenger service, starting on 7-in. piston travel. Do you recommend the use of the slack adjuster where the high speed brake is used? A.—The high speed brake undoubtedly causes the brake shoes to

heat up more in a heavy brake application than the ordinary brake would, and in emergency applications applies them to the wheels with greater force, so that there is nothing surprising in the fact that they occasionally break. To prevent this cracking or breakage from causing any inconvenience or trouble, however, brake shoes for high speed service should have steel backs to support them and to prevent the fractured parts from getting away, and steel backed brake shoes are now being extensively used in high speed brake service. Usually a steel backed shoe, fractured across its face at about the middle, will form itself better to the wheel tire in a brake application, and for this reason will hold better than a solid shoe. The American slack adjuster is recommended for use with the high speed brake, and it maintains the running piston travel at a predetermined amount. The running travel is always greater than the standing travel, and hence, when the adjuster takes up the slack to such extent as to cause the brakes to drag while released, it is an indication that the brake beams are weak, the brake rigging defective in design, or that there is too much lost motion in the truck transoms and journal boxes. A car whose total leverage is too high is also likely to give trouble because of the shoes dragging when brakes are released, if equipped with the slack adjuster adjusted to maintain 7-in. piston travel. This is because of the small shoe clearance originally permissible when the car is standing with the brakes released. If the running travel of the brake piston is not allowed to exceed the standing travel excessively, the slack adjuster cannot cause annoyance from taking up the slack too closely.

#### NEW YORK NO. 5 PUMP STOPS.

(45) J. E. H., East Buffalo, N. Y., writes:

A short time ago we had an annoying experience on one of our eastbound first-class passenger trains pulled by an engine equipped with the New York brake. The pump worked all right until a few miles from the terminal, when, without any apparent reason, it stopped and would not go to work again, and the air pressure kept falling. After stopping the train and using up about thirty minutes in trying to get it to work, it started, but didn't pump air as it ought to for the rest of the trip. At another time after that this same pump did the same thing, and caused a delay of a few minutes to the train. After the second failure, a Westinghouse governor bottom part was put on, and the pump has not failed since. Can you tell what the matter was? A.—The trouble very likely was caused by the pump governor. The diaphragm air valves in the New York governor were

probably leaking, allowing air to flow onto the governor piston continuously, causing it to hold the steam valve on its seat and cut off the flow of steam to the pump. By the time the Westinghouse governor body was applied it is probable the leakage had reduced, since it may have been caused by dirt on the air valve seat that finally became dislodged.

#### HAULING CAPACITY.

(46) J. W. M., Clarion, Pa., writes:

We have a locomotive here with 20x24-in. cylinders, 48-in. drivers, average steam pressure 115 lbs. How many tons should this engine haul up a five-mile hill, the grade being 2.5 per cent? A.—This engine should have a tractive effort of 27,000 lbs. The resistance due to a 2.5 per cent. grade would, at a velocity of 20 miles per hour equal 50 lbs. per ton, making the hauling capacity equal to 540 tons. The weight of the engine, tender and caboose would have to be deducted from this amount in calculating the load. The best published experiments on train resistances and grade computations are to be found on pages 293-300 in "Twentieth Century Locomotives."

#### LEAKY FLUES AND ENGINE JERKING.

(47) W. T. G., Clifton, Ore., writes:

1. What is the cause of the flues occasionally leaking when the pressure has dropped from 170 lbs. to 100 lbs. after work, and in a few minutes the leaking would stop? There is no sign of a leak while running even when the fire is very low. A.—The chief cause of intermittent leaks in flues is the sudden changes of temperature, generally caused by opening the furnace door too frequently, and sometimes by banking a portion of the fire, causing sudden sectional contraction. The flues cool more rapidly than the flue sheet so that small leaks occasioned by sudden cooling cease when the temperature becomes equable.

2. What is the cause of an engine jerking while going slow, and when running fast the jerking ceases? A.—The expression going slow is indefinite. This jerking may even be due to bad counterbalancing and excess weight may cause a disturbance at one speed which may disappear at another. In running slow with full valve travel there is not sufficient steam held in at the end of the stroke of the piston to cause compression. In running fast the compression or cushioning caused by earlier closing of the exhaust takes up all the constantly accumulating lost motion and prevents jerking.

#### EMPLOYMENT BUREAU.

(48) J. N., Perth Amboy, N. J., writes: Is there any employment office where a locomotive engineer can apply for employment or where an employer could secure an engineer? A.—There is no such agency.

# Air Brake Department.

CONDUCTED BY J. P. KELLY.

## Distributing Valve.

The method of piping the various valves that comprise the E.T. equipment having been fully illustrated and described in the March and April numbers, we are now prepared to take up in this

der brake cylinders with air from the main reservoir, the pressure in all will be equal, and the braking force in all brake cylinders uniform, regardless of piston travel.

Since the construction of the distrib-

ing automatic in its action, the brake cylinder pressure, corresponding to any given brake pipe reduction, is maintained constant throughout the whole application regardless of brake cylinder leakage.

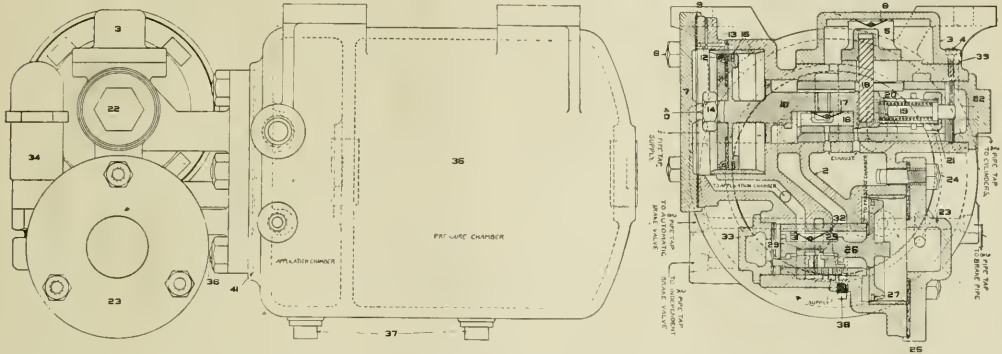

FIG. 1. DISTRIBUTING VALVE AND RESERVOIR, ALSO SECTION OF DISTRIBUTING VALVE.

number the consideration of the distributing valve, which is the most important one of this improved engine and tender brake equipment.

As already observed, this valve displaces all of the triple valves, auxiliary reservoirs, and the high speed reducing valves, used with the old equipment, and at the same time performs all of their functions in a more perfect and satisfactory manner. It is much more flexible in operation, it enables the engineer to regulate the brake cylinder pressure within any degree of refinement, and it makes it possible for him, without the exercise of that degree of judgment necessary with the present equipment, to make smooth and accurate stops, free from disagreeable shocks and injurious wheel sliding.

The advantages of this valve on modern locomotives, and in all kinds of service, are briefly as follows:

There are fewer parts; therefore, less likelihood of trouble because of defects.

Being simple in construction, it is easily understood; therefore, if a defect does appear, its presence may be promptly detected and the proper remedy applied.

Because it supplies all engine and ten-

dering valve and the method of piping it to the brake valves are such that the brake valve equalizing reservoir and the application chamber are connected, when the automatic brake valve handle

The foregoing being true, it follows that unless the brake pistons are allowed to strike the non-pressure heads of the brake cylinders, the engine and the tender brakes will be good ones, which is a

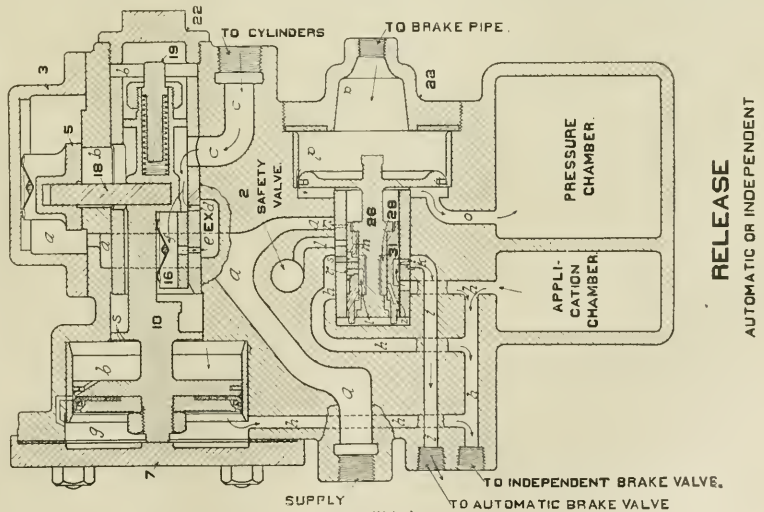

FIG. 2.

is placed in the emergency position, an increase in braking power of 20 per cent. is obtained on all the wheels of the engine and the tender. This counts for considerable in a close stop.

On account of the supply valve be-

desirable condition when making a stop, especially if it be an emergency one.

The distributing valve, longitudinally sectioned, and its reservoir are illustrated in Fig. 1. It will be noticed that the reservoir has two compartments in it,

one the pressure chamber, the other the application chamber; and that to this reservoir the distributing valve is bolted. All the pipe connections are made to the reservoir, and they communicate by means of cored passages with the dis-

tributing valve. From this we learn that the distributing valve may be removed and another applied, without disturbing the pipe joints.

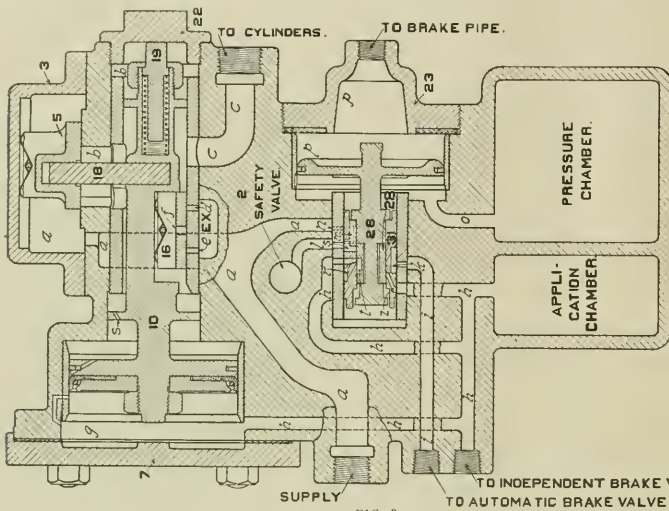

FIG. 3.

tributing valve. From this we learn that the distributing valve may be removed and another applied, without disturbing the pipe joints.

For the purpose of assisting in clearly describing the internal construction of the distributing valve and its operation, figures 2 to 9, inclusive, are employed.

These figures show all parts of the distributing valve and its reservoir as if they were one piece, and as if all the internal parts were on one plane; but this is merely to make it easier for us to follow the course of the air through the various ports and passages, and to understand the operation.

At the outset the most important figure to study is number 2, as this shows all parts in their normal, or release, position for both automatic and independent brake operation.

The brake pipe connection is indicated by the words "to brake pipe," and at this point the air enters the chamber behind the equalizing piston 20, and forces it to the position shown. The air then feeds through the small feed groove *p*, in the top of the piston bushing, into the pressure chamber, until the pressure on both sides of piston 26 is equal, precisely as it does through the feed groove in a triple valve in charging the auxiliary reservoir.

The application chamber communicates

cock to the automatic brake valve by means of the pipe connection thereto. The communication of passage *i* with the application chamber, however, is necessary only when the engine is the helper in a double-header. When such is the case, the double cut-out cock should be turned to cut out the auto-

The supply of air for the engine and the tender brake cylinders is taken from the feed valve pipe, although it may be taken direct from the main reservoir, which has a connection with the distributing valve, through the supply pipe, at the place marked "Supply." Air passes through the supply pipe and into passage and chamber *a*, leading to and surrounding supply valve 5.

The brake cylinder pipe connection is made at the point marked "To cylinders."

Besides leading to the independent brake valve, passage *h* also leads from the application chamber to chamber *g* behind the main piston 10. It should here be noticed that there is a small port leading from chamber *g*, which in release position registers with a small port through the main piston 10 to chamber *b*. This port performs the same function that the leakage groove in the brake cylinder does, namely, allows any slight leakage into chamber *g*, while brakes are released, to pass around the piston to chamber *b*, and then to the atmosphere, without moving this piston and applying the brake.

With the pressure chamber charged up equal to the brake pipe, a gradual reduction in pressure in the latter, say, of 10 lbs., will cause the pistons and slide valves of the distributing valve to take the positions shown in Fig. 3,

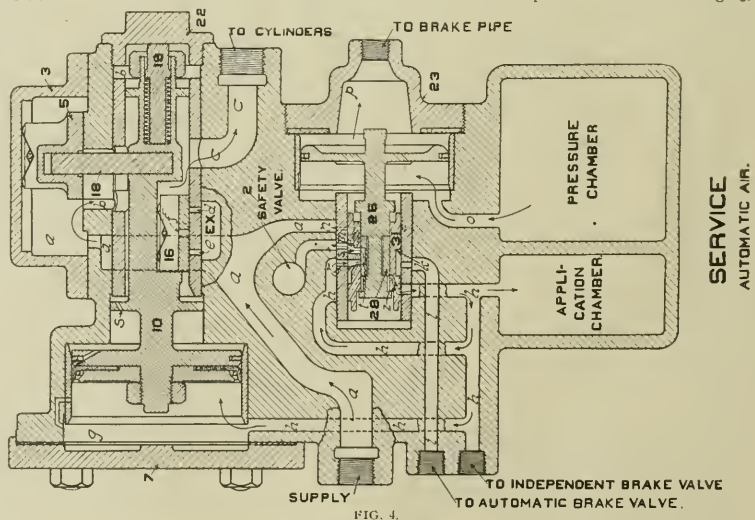

FIG. 4.

matic brake valve, and the handle of the latter should be placed in lap position. Then the engineer, operating the brakes, can operate those on the helping engine the same as he does those on the cars.

"Service, automatic air." Here it will be observed that the equalizing piston 20 has moved to the right, carrying with it the slide valves 28 and 31, a distance sufficient to bring ports *x* and *h* into



register, permitting air to flow from the pressure chamber into the application chamber, and into chamber *g*. Application chamber pressure is also had in the pipe leading from passage *h* to the independent brake valve, and in the one

below that in the brake pipe, the equalizing piston 26 moved back carrying the graduating valve 28, which is mounted on the top of slide valve 31, a sufficient distance to cause this valve to close, or lap, port *z*, and cut off further flow of

ways the same as that in the application chamber, it follows that the pressure developed in the brake cylinders must be the same as that in the application chamber, because air must flow to the brake cylinders until the pressure is sufficient

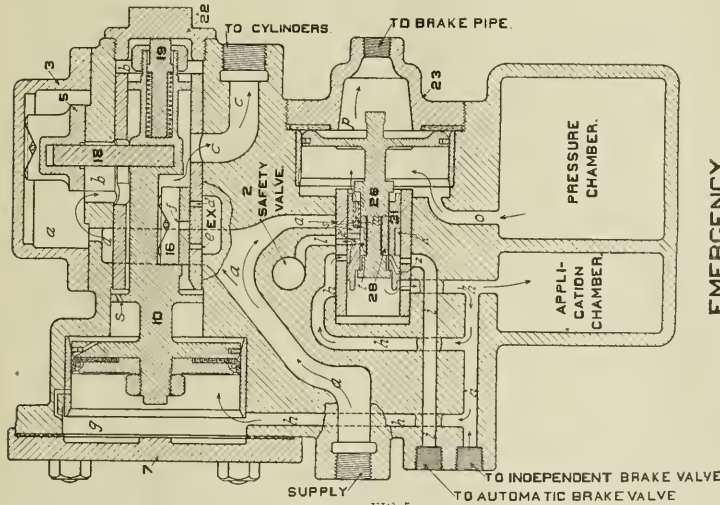

FIG. 5.

leading from this brake valve to the automatic brake valve, during a brake application. The pressure thus formed in the application chamber and in chamber *g* acts upon main piston 10, and forces it together with the supply valve 5 and the exhaust valve 16 to the right, as shown in this figure, uncovering the supply port *b* leading to and closing the exhaust port *e* and *d*, leading from the brake cylinders. The supply valve 5 in chamber *a* is always under pressure from the feed valve pipe, and as soon as port *b* is opened the air flows from chamber *a* through this port and passage *c* to the engine and the tender brake cylinders, and applies the brakes. When the pressure in chamber *b* and the brake cylinders is equal to or slightly in excess of that in chamber *g*, the spring surrounding stem 19, which is compressed when main piston 10 is moved to the right, forces this piston to the left until supply valve 5 laps port *b* and cuts off further supply of air to the brake cylinders; that is, to the position shown in Fig. 4. "Service lap, automatic air." In doing this, however, it does not disturb exhaust valve 16. The position of the valves and the pistons, as shown in this figure, should be carefully observed. When the pressure in the pressure chamber had reduced by expansion into the application chamber to a point slightly

air from the pressure chamber to the application chamber. Because the volume of the latter chamber is in the same ratio to the volume of a brake cylinder having 8 in. piston travel is to that of its auxiliary reservoir, the same pressure is developed in the application

in chamber *b* to cause piston 10 and supply valve 5 to move back to lap position. Should brake cylinder leakage reduce the pressure in chamber *b* below that in chamber *g* during the time that the brakes are to remain applied, piston 10 and supply valve 5 will move to the right, automatically open port *b* sufficiently to admit air to supply the leakage, and thus maintain the pressure constant in all brake cylinders.

It can also be easily seen that a further reduction in brake pipe pressure will cause the equalizing piston to move to the right again and carry with it the small valve 28, which will uncover port *z* and admit air from the pressure chamber to the application chamber, until the pressure chamber pressure is slightly lower than the brake pipe pressure when the equalizing piston will move back and cause slide valve 28 to lap port *z* again. This operation may be repeated until the pressure in the two reservoir chambers becomes equal, after which, of course, the brakes cannot be applied any harder. Just as with the older brake, a 20 lb. service reduction applies the brake in full, giving, with a 70 lb. brake pipe pressure, 50 lbs.

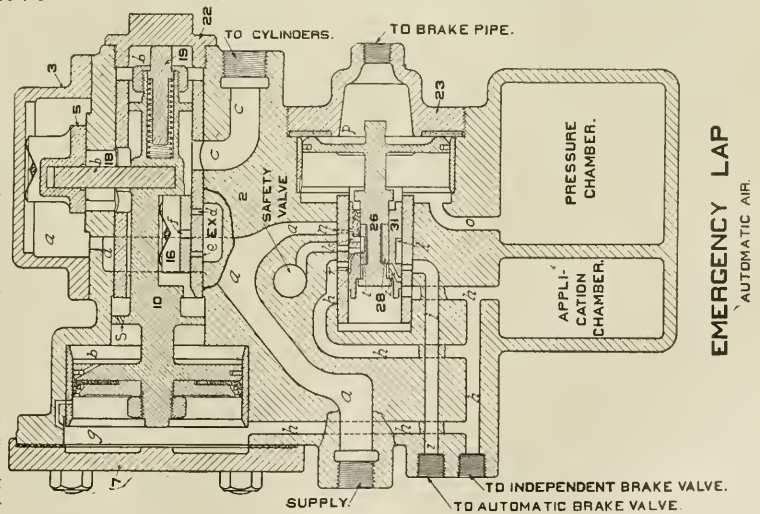

FIG. 6.

chamber for any given brake pipe reduction that would be developed in a brake cylinder, having the proper auxiliary, for a like reduction.

As the pressure in chamber *g* is al-

equalizing piston 26 moves to the ex-

ylinder pressure. In emergency applications the valves and pistons take the position shown in Fig. 5. "Emergency, automatic air."

Equalizing piston 26 moves to the ex-

trème right, equalizing slide valve 31 uncovers port *h* entirely, so that the application and the pressure chambers will equalize quickly, main piston 10 and supply valve 5 will move instantly to the right, and the brakes will apply with a

The equalizing piston does not operate in independent brake applications. The position of the main piston and of the supply valve in an independent application is shown in Fig. 8, and their positions in independent release and in

service *l*, and is in communication with the application chamber only when the equalizing piston is in the position shown in Figs. 3, 5 and 6. Since the pressure in the brake cylinders can be no greater or no less than it is in this chamber, it will be seen that to relieve the surplus brake cylinder pressure all the safety valve has to do is to carry off the small volume of excess air in the application chamber.

Referring to Fig. 3, service position, it will be seen that there is a cavity, *l*, in the graduating valve 28, which in this position connects passage *h*, port *r* in the seat of the graduating valve, and ports *s* in the equalizing valve with passage *l*, leading to the safety valve. These ports and passages are of ample capacity to carry away the air from the application chamber as fast as it can enter through port *z*, whenever the pressure in the application chamber is up to the limit of adjustment of the safety valve, and the latter is open so as to exhaust it to the atmosphere.

**RELEASE POSITION**  
WHEN LOCOMOTIVE BRAKE IS RELEASED BY INDEPENDENT BRAKE VALVE AFTER AN APPLICATION BY BRAKE PIPE REDUCTION.

With the high speed brake using 110 lbs. brake pipe pressure, the safety valve will prevent the application chamber pressure increasing above 60 lbs. in service applications.

In the emergency position, Fig. 5, the small port *n* in the graduating valve seat and port *m* through the graduating valve are in register, and main reservoir air

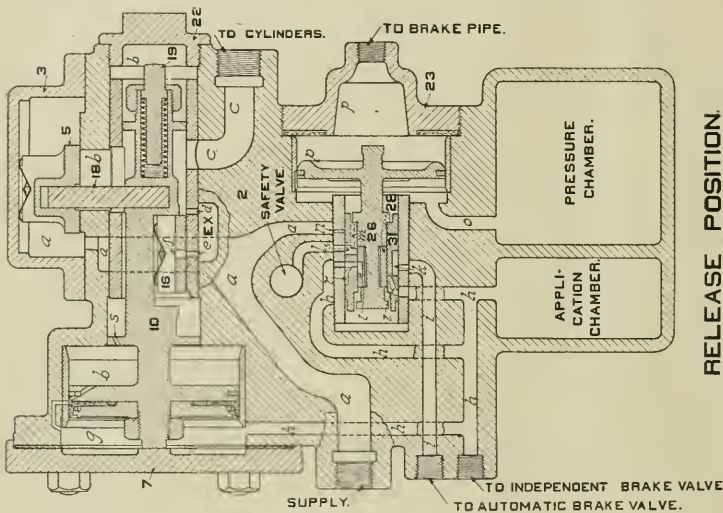

FIG. 7.

force about 20 per cent. greater than in full service application.

This increased braking force in emergencies is obtained, as already stated, by connecting the brake valve equalizing reservoir with the application chamber, thus increasing the pressure in the latter about 20 per cent.

When full emergency brake cylinder pressure is obtained, main piston 10 and supply valve 5 move back to the lap position, as shown in Fig. 6, "Emergency lap, automatic air."

If the brakes are released with the independent brake valve, after being applied in service with the automatic brake valve, the valves and pistons take the position shown in Fig. 7. That is, the equalizing piston and slide valve return to the lap position, and main piston 10 and supply valve 5 return to release position, the application chamber being relieved of pressure. When the brakes are applied with the independent brake valve, air is admitted direct to the application chamber and to chamber *g* through the independent brake valve pipe connection thereto, and the main piston 10 and supply valve 5 are the only ones to operate. The pressure in chamber *g* may be varied at will with the independent brake valve, after the brakes are applied with a service reduction.

lap positions are shown in Figs. 1 and 9. Before proceeding further it will be necessary to state that the equalizing piston 26 is made to appear as though it carried two slide valves, one on the upper and one on the lower side of its stem, but that which appears on the upper side as a slide valve is really a

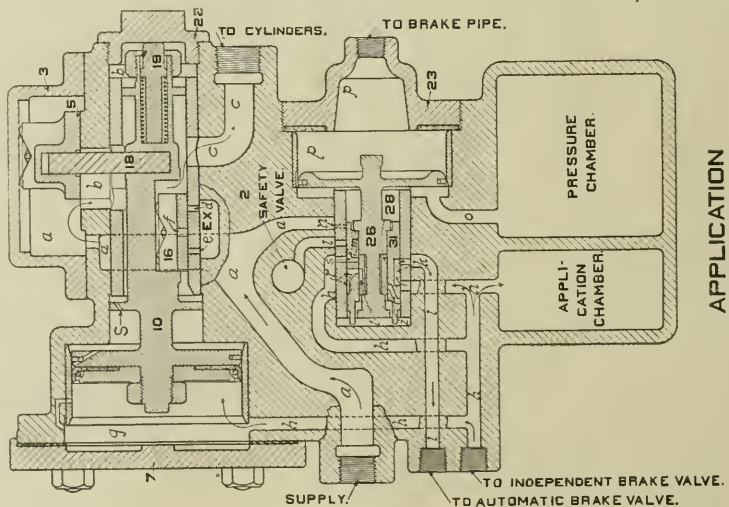

FIG. 8.

part of slide valve 31 and graduating valve 28, so placed on purpose to make it easier for us to see all the ports in the valve and its seat.

The safety valve is screwed into pas-

can flow, in a limited quantity, into the pressure and application chambers, which in this position are in full communication. It should also be noticed that port *h* is connected to passage *l* by a

much smaller port in the equalizing slide valve. This restricted port retards the escape of air through the safety valve, so as to maintain the pressure at 60 lbs., regardless of brake pipe pressure used.

When using the high speed brake an emergency application will develop a pressure of approximately 85 lbs. in the application chamber and, of course, in the brake cylinders, and this pressure will be reduced gradually to 60 lbs. in about the same time that the high speed reducing valves on the cars reduce the brake cylinder pressure to 60 lbs.

An important feature in connection with the operation of the distributing valve should here be noted. Should it happen that through careless operation of the automatic brake the pressure in the brake pipe and the chamber should fall below the normal usually carried, an emergency application, if needed, would result in placing the equalizing piston and slide valves in the position shown in this figure, and air would flow into the pressure and the application chambers through ports *n* and *m*, raise the pressure in chamber *g* to the adjustment of the safety valve, and thus maintain the brake applied with full force. This feature makes it impossible so to manipulate the brakes in automatic applications as to render the brake on the engine and the tender inefficient.

Glancing at the collar on main piston 10, it will be seen that it has a small port *s* through it. The function of this port is to cause a slow rise in pressure on the left of the main piston, and thus prevent it from vibrating.

Having learned from the foregoing description, and from the illustrations, the general construction and operation of the distributing valve, it will now be in order to notice how the distributing valve responds when the brake valves are operated.

To begin, both brake valves when not in use should be carried in running position, except in cases of double heading, when, as already stated, the double cock on the helper engine should be closed and the handle of the automatic brake valve should be placed on lap.

To make an independent brake application, the handle of the independent brake valve is moved to the application position. This admits air direct through port *h* to the application chamber and chamber *g*, where the pressure can act directly on main piston 10, forcing it and the supply valve to the position shown in Fig. 8, admitting air to the brake cylinders.

The pressure that can be admitted to the application chamber through the independent brake valve cannot rise above 45 lbs., as this is the pressure at which the reducing valve, which does duty for both the independent brake and the train air signal, is adjusted. Moving the handle of the independent brake valve to release position permits the air to escape from the application chamber, and the brakes to release. This operation is so simple that it can easily be seen that the brake application can be graduated on and graduated off perfectly.

Reference to the piping diagrams and their descriptions, referred to above, will enable the reader to understand how the brakes on the engine and the tender are held applied with the automatic brake valve while releasing the train brakes and then graduated off as desired, since the pipe connection between the inde-

pendent cap bolt and nut, 24; cylinder cap gasket, 25; equalizing piston, 26; equalizing piston packing ring, 27; equalizing piston graduating valve, 28; graduating valve spring, 29; equalizing slide valve, 31; equalizing slide valve spring, 32; cap nut, 33; E-1 safety valve, complete, 34; reservoir, complete, 35; reservoir stud and nut, 36; reservoir drain plug, 37; pipe plug in distributing valve body, 38; supply valve cover gasket, 39; cotter for main piston, 40; reservoir gasket, 41.

**Test of Lubrication.**

Some interesting facts regarding lubricating with flake graphite were brought out in a test made at Purdue University not long ago. Among other things it developed that two wearing surfaces were kept rubbing on each

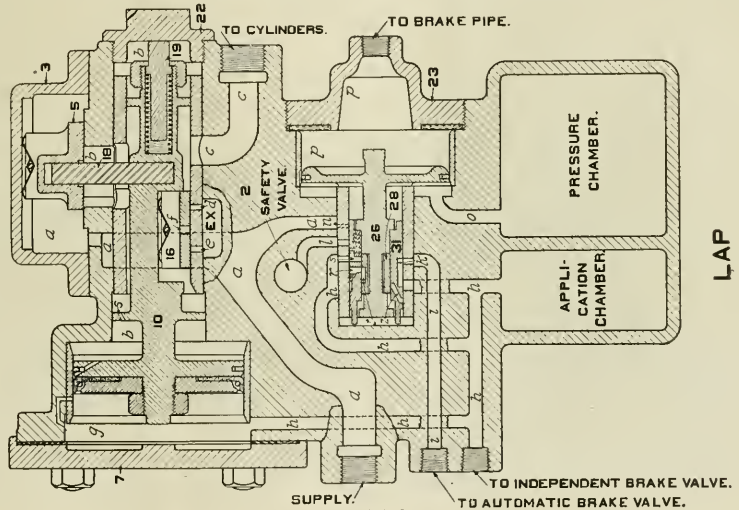

FIG. 9.

pendent and the automatic brake valves is only a continuation of that between the distributing valve and the independent brake valve.

To assist in the satisfactory discussion of the distributing valve and to assist our correspondents to understand us when answering questions about it, we give below a list of the names of the parts and their numbers: Body, 2; supply valve cover, 3; supply valve cover screw, 4; supply valve, 5; supply valve spring, 6; cylinder cover, 7; cylinder cover bolt and nut, 8; cylinder cover gasket, 9; main piston, 10; main piston follower, 11; packing leather expander, 13; main piston nut, 14; main piston packing ring, 15; exhaust valve, 16; exhaust valve spring, 17; supply valve stem, 18; main piston graduating stem, 19; main piston graduating spring, 20; main piston graduating stem nut, 21; cap nut and piston stop, 22; cylinder cap,

other and wore away under a maximum pressure of 50 lbs. to the square inch, and the testing machine made more than 600,000 revolutions in doing the work. The lubricant used was kerosene and the co-efficient of friction was .00547. When the lubricant was made up of two parts kerosene with one part Dixon's flake graphite things began to change. A maximum pressure between the wearing surfaces of 110 lbs. per square inch was secured and the co-efficient of friction came down to .00459. The use of kerosene oil in this test was for the purpose of bringing out strongly the part which flake graphite plays when used as a lubricant. Those who wish to secure a fuller account of this interesting test can do so by writing to the Joseph Dixon Crucible Company, of Jersey City, N. J., and asking them for the April copy of their little publication called Graphite.

### The Man Who Sells Things.

"When the man who sells things is not abroad in the land there is 'nothing doing.'" That is one of the many good things which were said, and all of them were well said, by Mr. George A. Post, president of the Standard Coupler Company of New York, at one of the recent sessions of the Railway Club of Pittsburgh. He thinks the man who sells things is entitled to a university degree. When addressing the club he spoke as follows:

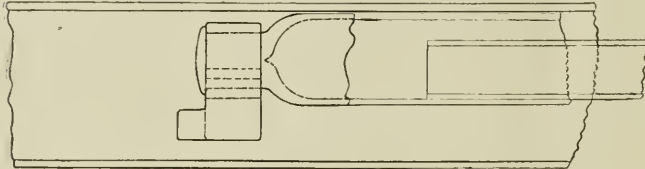

DETAIL OF HEADER USED IN SCHENECTADY SUPERHEATER.

"These are prosperous days in business circles. Printeries and binderies are busy making order books wherein can be entered the tremendous demands for materials of all kinds flowing in to the factories of our country.

"What does this prosperity mean in its generic sense? What causes railroads to buy cars by the thousands and locomotives by the hundreds? It means and it is because there have been sales made of all kinds of material entering into the consumption of busy mankind in all quarters of the country.

"Sales necessitate transportation, transportation calls for power and vehicles, and so the results of sales ramify into every nook and cranny of civilization. Sales light the furnace fires, blacken the sky with smoke, set ponderous machinery in motion, quicken

world is languishing, and when it is done, unless you get next to a man who can make people believe they need it and sell it to them, your trousers will be frayed at the edges and your stomach will know the pangs of hunger. The best friend of everybody is the man who sells things. He who would sell things must be patient, tactful, broad-gauged, generous, good-natured and tireless. For him no whistle blows to sound the end of his daily toil. For him there are but few peaceful evenings at

his home fireside. For him it is hustle, hustle, hustle.

"In his travels up and down the highways he seeks audience with and tells his tale to men of varying titles. In the railway trade he goes to presidents, general managers, superintendents of motive power, civil engineers, mechanical engineers, electrical engineers, sanitary engineers, engineers of tests, and, in fact, runs the gamut of every conceivable degree of titled importance, and besides, he is ever and always up against that most august personality, the office boy, and to all of these the man who sells things comes under the general characterization of 'Drummer' or a 'Supply Man,' terms that are not intended to dignify, and are more or less terms of opprobrium.

"Now, I think that after a man has a

sells things, and have not learned things and have not learned half as much in the same period of time.

"Fit up the most luxurious offices, take a whole floor in the most conspicuous block in Pittsburgh, go out and buy broad acres and erect magnificent works, fit them up with all the most modern machinery, and you would never pay the laboring man one cent, the landlord would evict you for the non-payment of the rent of your luxurious offices, if the fellow with the carpetbag, away from home, plunging through midnight blackness, putting up with all sorts of discomforts, was not sending in his orders so that the wheels might go round and so that a cross-grained auditor might earn his salary by finding fault with the expense account.

"Let's give the man who sells things, so that the other fellows with degrees may receive their salaries promptly—a degree. What shall it be? I confess I am fond of the 'engineer' style. Now, if I remember the definition of an 'engineer' as recorded in the dictionary, it is not confined to those who have to do only with technical work, but it also calls it 'engineering' where one carries through by skill and contrivance a business deal. What's the matter with calling him a 'Commercial Engineer'? If there is anybody who knows more than the man who sells things about wheels within wheels, slipping a cog, eccentrics, joints, bulldozers, lost motion, making connections, laying pipe, pumping, plugging, and working under high pressure, just trot him out and we will give him a degree that will fit him.

"All honor, I say, to the man who sells things. When he is not abroad in the land there is 'nothing doing.' So

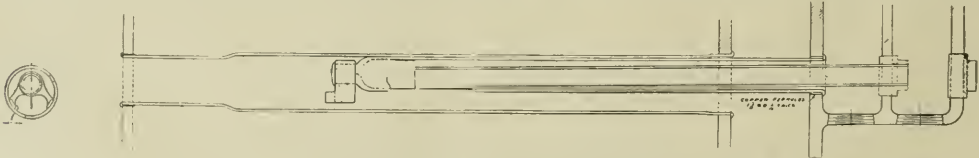

ARRANGEMENT OF PIPES IN THE SCHENECTADY SUPERHEATER, D., I. & W. ENGINE.

the demands for labor, and spread the smile of plenty over the land. He who sells things is the apostle of happiness, the bulwark of prosperity. Who fills the hotels, crowds the trains, and loads the freight cars with tonnage? The man who sells things. Of what commercial value is the most useful and wonderful device that was ever invented, unless it is exploited by the man who knows how to sell it?

"Oh, you who pride yourself upon the possession of inventive genius, cudgel your brains, burn the midnight oil, wallow in problems of sky-high mathematics, produce, if you can, something for which you think a waiting

record of service in selling things, has attended that severest of all schools, namely, contact with the world; after he has been chilled to the marrow by refrigerated receptions; after he has been tried out in the crucible of competition; after he has overcome the mountains of obstacles that beset his path, and 'made good,' I think he should have a degree conferred upon him.

"Our universities are turning loose doctors, masters and bachelors of this and that and the other thing, and engineers of all kinds and descriptions, to gain which degrees the recipients have undergone not one tittle of the hard work and self-sacrifice of the man who

sure as the rising sun foretells the coming of the day, so does the appearance of the man who sells things foretell commercial activity, and just in proportion as he succeeds the tide of prosperity ebbs or flows. The man who brusquely turns him down, or who affects to be bored by his presence, or who bars him from his office, does an injustice to the interests confided to his care, and also robs himself of a large amount of information that he needs in his business."

The general offices of the Erie Railroad have been moved to the Bowling Green building, No. 11 Broadway, N. Y.

### Culm Burner for the D., L. & W.

Some time ago the Delaware, Lackawanna & Western Railroad, often called the "dustless road of anthracite," secured some 4-4-0 engines from the American Locomotive Company. The engines were built at Schenectady, and are simple, fine hard coal burners, with piston valves, and are used in passenger service.

The engines, one of which is shown in our illustration, have cylinders 20x26 ins. and driving wheels 69 ins. in diameter, and with a boiler pressure of 185 lbs. per square inch the calculated tractive effort is about 23,710 lbs. There are about 100,000 lbs. on the drivers, and this makes the ratio of tractive effort to adhesive weight stand as 1 is to 4.21. The driving wheel base is 8 ft. 6 ins., and that of the engine itself is 24 ft. 5 ins. All the wheels on the engine and tender are braked.

close to 433 ins. Both arms of the rocker are above the shaft.

The boiler of this engine is built with a wide fire box of the Wootten type, and is 100 ins. wide by 126 $\frac{1}{2}$  ins. long. The grate area is 87.54 sq. ft. The boiler may be described as a straight top one, with an inside diameter of 60 ins. at the smoke box end. The second course is slightly tapered underneath, and where the waist joins the throat sheet the boiler measures 66 $\frac{1}{2}$  ins. in diameter. The grates are arranged for the burning of fine anthracite fuel, and the size of the fire box necessitates a centrally placed cab. The heating surface in the fire box amounts to 100.8 sq. ft. and the tubes give 1,047.89 sq. ft., making a total of 2,138.69 sq. ft. There are 280 tubes, 13 ft. 4 $\frac{1}{2}$  ins. long. The engine equipped with the Schenectady superheater has 152 tubes 13 ft. long and 60 superheater tubes.

Valves—Steam lap, 1 ft.; clearance 1/16 in.  
Setting—1/16 in. lead in full gear ford.; and shift back up eccentrics to give 1/4 in. lead at 6 ins. cut-off ford. motion.  
Wheels—Engine truck, diameter, 33 ins.; tender, 33 ins. disk.

### New Coaling Station.

A new feature in connection with the extensive shops in course of construction by the Pennsylvania Railroad near Trenton, N. J., is the coaling station which is already in operation. This station affords another proof of the utility of expanded metal in modern buildings. The foundation is of heavy concrete, with steel columns 15 ft. apart, between which there are three vertical panels of stone concrete reinforced by expanded metal. The floor of the bunker proper consists of a doubly inclined slab of concrete 5 ins. in thickness reinforced with 3-inch mesh expanded metal. There are fifteen openings at each side

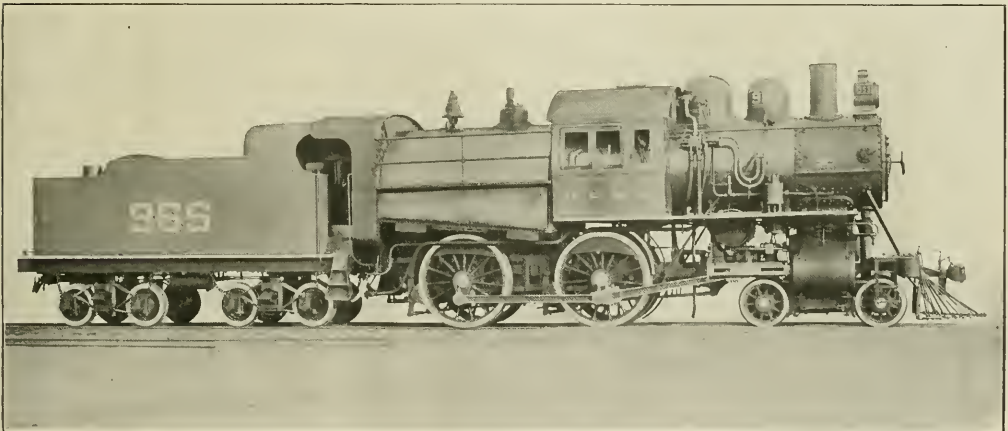

SIMPLE 4-4-0 ENGINE WITH SUPERHEATER FOR THE D., L. & W.

© R. F. Killpatrick, Superintendent of Motive Power.

American Locomotive Company, Builders.

The piston valves, which are 12 ins. in diameter, have a travel of 5 $\frac{1}{2}$  ins. The rocker is placed well forward and has what is called a crosshead attachment to the valve rod; the back end of the rod works in a very substantial guide. The motion, though usual in appearance, is direct, there being a straight transmission bar passing from the link-block up to the upper end of a rocker arm which is above the rocker shaft and is inclined at such an angle as will be at right angles to the line of the transmission bar when in the central position. The outside rocker seen in the half-tone is 12 $\frac{1}{2}$  ins. long, while the inclined rocker at the back of it, to which the transmission bar is attached, is 11 ins. long, and as the valve has a travel of 5 $\frac{1}{2}$  ins., it follows that the throw of the eccentrics must be very

The tender has the ordinary U-shaped tank, which holds 5,000 U. S. gallons of water and carries 10 tons of fuel. The frame is made of 10-in. steel channels and plates, and is mounted on two arch bar trucks. The tank has a hood arch or cab for the protection of the fireman, as well as the fireman's cab on the engine itself. Some of the principal dimensions are as follows:

Wheel Base—Total, engine and tender, 51 ft. 3/4 in.

Weight—In working order, 151,200 lbs.; engine and tender, 261,200.

Axes—Driving journals, 02x3 ins.; engine truck journals, diameter, 6 $\frac{1}{2}$  ins.; length, 12 ins.; tender truck journals, diameter, 5x0 ins.

Fire Box—Thickness of crown, 3/8 in.; tube, 9/16 in.; sides, 3/8 in.; back, 3/8 in.; water space, front, 4 ins.; sides, 4 ins.; back, 4 ins.

Crown Staying—Radial. Pump 9 $\frac{1}{2}$  ins. R. H. Reservoir, 26 $\frac{1}{2}$ x50 ins.

Engine Truck—Four wheel swing center bearing. Piston—Rod diameter, 3 $\frac{1}{2}$  ins.; piston packing, C. I. rings.

of the bunker, and the coal can be entirely emptied without the necessity of shoveling. The structure has an elegant and light appearance, not usual in such buildings, the whole being finished outside and in with a neat facing of cement. The concrete itself could not bear the strains induced by the weight of coal, but the use of expanded metal and concrete makes a structure that is permanent, while the cost is not much more than a wooden structure would be. The New York branch of the Expanded Metal Company furnished the material.

An official decree has been issued by the Peruvian Congress authorizing the President of the Republic to construct a railway from Oroya to the city of Tarna. The existing railway lines in Peru are said to be successful.

### Patent Office Department.

As we have previously stated, the space at our disposal being necessarily limited, it is impossible to give other than a brief synopsis of the chief features of what seem to us to be the most noteworthy inventions of the month. Those desiring complete descriptive details can procure a copy of the patent from the Commissioner of Patents, Washington, D. C., by referring to the numbers which we append and by sending 5 cents to him; stamps will not do.

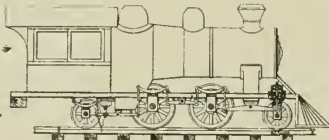

TRACTION INCREASER.

#### TRACTION INCREASING MECHANISM.

Mr. Fred L. Sheldon, Tacoma, Wash., has patented an improved traction mechanism, No. 816,505, consisting of a combination with drive wheel trucks, front and rear pony trucks, a main lever pivotally mounted on a standard with an intermediate lever pivotally mounted upon the frame, and means for connecting the spring hangers, thereby equalizing and distributing the weight over the entire wheel base and increasing the tractive effort of the engine. The plan, as shown in the illustration, is admirably suited to balance a four coupled locomotive.

#### LOCOMOTIVE SAND BOX.

Mr. W. H. Clowry, Chicago, Ill., has patented a sand box for use on loco-

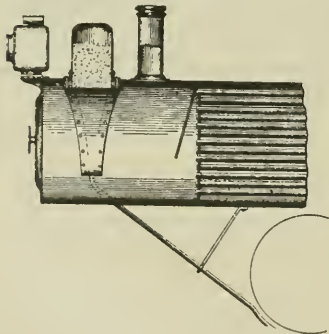

SAND BOX ON SMOKE BOX.

motives, No. 816,073. As shown in the illustration, the sand box is placed forward of the steam space, and consists of an outer receptacle secured to the boiler shell, and adapted to be heated by the heat of the locomotive, and furnished with pipes on opposite sides of the boiler passing through the boiler shell into an arched interior tapering chamber and conveying the sand to the rails when required.

#### SMOKE CONSUMER.

A smoke-consuming apparatus for furnaces, No. 814,230, has been patented by Mr. J. P. McMahon, Renovo, Pa. The contrivance consists of a series of pipes opening into the fire box near the opening of the flues, and arranged to discharge a mixture of oil and steam in the path of the products of combustion, thereby establishing a combustible barrier at the front of the fire box, which is said to wholly consume the products of its own combustion. An adjustable appliance furnishes means of responding to the opening and closing of the door of the fire box, for controlling the steam and oil supply.

#### SNOW AND ICE FLANGER.

A flanger for cleaning railroad tracks, No. 816,526, has been invented and patented by Mr. F. C. Arey, Chicago, Ill. The combination embraces a supporting frame carrying deflecting blades above the rails in front of the truck wheels, and means for permitting the blades to yield when a heavy object is engaged. The flanging blades effectively clean light snow or ice from the rails, and the springs which permit the blades to yield to hard substances are sufficiently strong to maintain the blades in their proper position while in contact with light substances.

#### BRAKE HANGER.

Mr. W. O. Webster, Philadelphia, Pa., has patented a brake hanger, No. 814,489, consisting of a bracket secured to the frame of a truck, the bracket having a transverse curved pocket at its outer end, the bracket having a bearing face directly under the pocket, a rod carrying a brake shoe, the rod having an enlarged upper end bearing against the under side of the bracket and having a stem extending through a slot in the bracket. Adjustable nuts on the stem of the rod readily keep the parts in proper position, and the incidental lost motion is easily taken up. The contrivance is well suited for engine or car trucks, and has been assigned to Burnham, Williams & Co., Philadelphia, Pa.

#### FLUE EXPANDER.

Mr. O. Swanson, Chicago, Ill., has invented and patented an improved flue expander, No. 814,248. The apparatus consists of a shaft tapered inwardly from one of its ends and adapted at the other end to engage means for giving it rotary motion with a pair of collars spaced apart and fixed on the shaft near its power engaging end. An externally screw threaded outer sleeve is interposed between the two collars, and an auxiliary sleeve extends toward the tapered portion of the shaft. A roller nest or recess is secured within the auxiliary sleeve and rollers are loosely mounted in several openings. The mechanism differs from the Dudgeon

expander in the fact that the threaded sleeve draws the taper shaft slowly outward and the expansion of the flue is not dependent upon the irregular forcing of a taper plug by hammering.

#### STUFFING BOX.

An ingenious improvement on stuffing boxes has been invented and patented by Mr. F. W. Felsberg, Dayton, Ky., No. 816,455, consisting of a casing having a plurality of fixed threaded

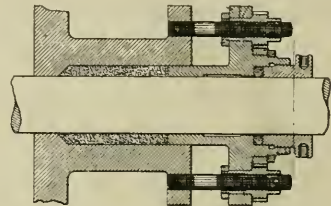

METHOD OF TIGHTENING GLAND.

bolts projecting therefrom, a gland, a plurality of gear-nuts rotatably mounted on the bolts, an idler-gear concentric with the shaft and meshing with the gear-nuts, the arrangement being such that all parts of the gland will be moved a uniform distance parallel to the shaft when a rotary movement is given to any one of the nuts. The contrivance precludes the possibility of the gland bearing irregularly on the shaft or piston.

#### BOILER.

A form of boiler has been patented by Mr. William N. Rumely, Laporte, Ind. In addition to the usual enclosed fire box with extended shell and flues, the sides of the fire box are formed continuous with its floor, as shown in the accompanying illustration, the floor of the fire box forming a curve with its concavity upward, with cleaning openings in the throat sheet and outer door sheet, at the forward and rear extremities of the spaces formed between the floor of the fire box and the base corners of the shell.

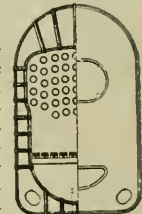

ENCLOSED ASH PAN

#### LOCOMOTIVE HEADLIGHT CASING.

A casing for locomotive headlights, No. 814,030, has been patented by Mr. E. A. Edwards, Cincinnati, Ohio. The claims embrace a headlight and goggle-glass, and a supplemental reflector arranged for reflecting a portion of the light upward on a translucent shade, and means for moving the shade across the face of the goggle below the reflector. An adjustable roller readily moves the shade and auxiliary reflector.

# Of Personal Interest.

Mr. W. Cousley has been appointed master car builder of the Chicago, Peoria & St. Louis.

Mr. J. C. Mengel has been appointed master mechanic of the Northern Central, with headquarters at Baltimore, Md.

Mr. E. J. Davis has been appointed master mechanic of the Washington, Idaho & Montana, with headquarters at Palouse, Wash.

Mr. John T. Carroll has been advanced to assistant general foreman of the Lake Shore's locomotive shops at Collinwood, O.

Mr. F. K. Murphy has been appointed brake inspector of the Big Four, vice Mr. L. H. A. Albers, promoted to supervisor of air brakes.

Mr. Fred C. Wilson has been appointed general foreman of the Southern Railway at Toccoa, Ga., vice Mr. E. L. Harris, promoted.

Mr. J. W. Smith has been appointed traveling engineer of the Montana division of the Great Northern, vice Mr. G. Herren, promoted.

Mr. C. L. Meister has been appointed mechanical engineer of the Atlantic Coast Line Railway, with headquarters at Wilmington, N. C.

Mr. S. E. Flanagan has been appointed assistant superintendent of the New Orleans & Northeastern, with headquarters at New Orleans, La.

Mr. C. K. Shelby has been appointed master mechanic of the Northern Central, with headquarters at Elmira, N. Y., succeeding Mr. John M. Henry.

Mr. A. L. Comstock has been appointed traveling engineer on the Nashville division of the Illinois Central Railroad, with headquarters at Princeton, Ky.

Mr. John M. Henry has been appointed master mechanic of the Pennsylvania, with headquarters at Sunbury, Pa., vice Mr. J. C. Mengel, transferred.

Mr. C. D. Kuerth has been appointed general foreman of the Chicago, Rock Island & Pacific at Herington, Kan., vice Mr. W. M. Evans, resigned.

Mr. W. H. Rother has been appointed road foreman of engines on the Chicago division of the New York Central lines west, with headquarters at Indianapolis, Ind.

Mr. P. J. Schuyler has been appointed road foreman of engines of the Harrisburg division of the Philadelphia & Reading, with headquarters at Harrisburg, Pa.

Mr. H. Jackson has been appointed master mechanic of the Interocianico Railroad of Mexico. He was formerly

general foreman on the International of Mexico.

Mr. J. T. Wallis has been appointed master mechanic of the Pennsylvania, with headquarters at West Philadelphia, Pa., vice Mr. D. M. Perine, promoted.

Mr. E. L. Harris, formerly general foreman at Toccoa, Ga., has been promoted to the position of master mechanic on the Southern Railway at Macon, Ga.

Mr. Miles Gibson has been appointed road foreman of engines of the Cleveland, Cincinnati, Chicago & St. Louis at Mt. Carmel, Ill., vice Mr. Homer Baldwin, resigned.

Mr. Frank H. Sweringen, car foreman of the Chicago, Rock Island & Pacific shops at Cedar Rapids, has been appointed master car builder of the same road at Chicago.

Mr. Alfred Walter, chairman of the board of the South & Western, has been elected president of the Seaboard Air Line, succeeding Mr. J. M. Barr, resigned as president.

Mr. Tom R. Davis has been appointed mechanical expert and traveling representative of the Flannery Bolt Company, of Pittsburgh, Pa., who make the Tate flexible staybolt.

Mr. W. M. Wilson has been appointed western representative, residing at Chicago, for the Flannery Bolt Company, of Pittsburgh, Pa., manufacturers of the Tate flexible staybolt.

Mr. J. A. Middleton, first vice-president of the Lehigh Valley, has recently been placed in charge of the operation and maintenance of the company's lines, with office in New York City.

Mr. D. M. Perine, master mechanic of the Pennsylvania at West Philadelphia, has been appointed superintendent of motive power of the same road, with headquarters at Williamsport, Pa.

Mr. E. C. Huffman, division master mechanic of the Great Northern at Breckenridge, Minn., has been transferred to Sioux City, Iowa, as master mechanic of the Sioux City division.

Mr. H. A. Hodges, foreman in the Baltimore & Ohio shops at Brunswick, Md., has been appointed general foreman of the same shops on the B. & O., vice Mr. Z. T. Brandtner, transferred.

Mr. Oscar Dunton has been appointed master mechanic of the Kentucky Valley Railroad, with office at Providence, Ky. This road was put in operation about the middle of March last.

Mr. George W. Stillwagon has been appointed master car builder of the

Pittsburgh, Shawmut & Northern Railroad Company, in charge of all car work, with headquarters at St. Mary's, Pa.

Mr. W. Munro has been appointed master car builder in the general repair and construction shops of the National Railroad of Mexico, with headquarters at Santiago, vice Mr. F. C. Sharpe, resigned.

The jurisdiction of Mr. S. F. Pryor, general purchasing agent of the Missouri Pacific, has been extended over the Texas & Pacific, St. Louis Southwestern and International & Great Northern.

Mr. T. N. Jarvis has been elected second vice-president of the Lehigh Valley Railroad, and has charge of that company's freight, coal and passenger traffic, with office at 143 Liberty street, New York.

Mr. W. T. Tyler, formerly general superintendent of the St. Louis, Iron Mountain & Southern, has been appointed general manager of the Louisiana & Arkansas, with headquarters at Texarkana, Ark.

Mr. O. M. Laing, assistant superintendent of the Central New England, has been appointed superintendent of the same road, with headquarters at Hartford, Conn., succeeding Mr. J. F. Hedden, resigned.

Mr. William Adams, who for a number of years has been a locomotive engineer on the Wabash Railroad, has been promoted to the position of assistant master mechanic on the same road, with headquarters at Bluffs, Ill.

Mr. G. W. Seidel, formerly master mechanic on the Chicago, Rock Island & Pacific at Horton, Kan., has been appointed superintendent of shops at East Moline, Ill., on the same road, vice Mr. A. W. Wheatley, resigned.

Mr. G. W. Smith has been promoted to the position of master mechanic at Fort Wayne, Ind., on the Wabash Railroad, with jurisdiction over the Buffalo, Detroit and Peru divisions, vice Mr. E. F. Needham, transferred.

Mr. E. J. Smith, formerly master mechanic of the Atlantic Coast Line Railway at High Springs, Fla., has been appointed assistant superintendent of motive power of the same road, with headquarters at Jacksonville, Fla.

Mr. Tom P. Mooney, machinist at Monet, Mo., has been promoted to be foreman at Bessie, Okla., on the St. Louis & San Francisco. Mr. Mooney served his time on the 'Frisco, and has a thorough knowledge of his business.

Mr. Z. T. Brandtner, formerly general foreman of the Brunswick shops of the Baltimore & Ohio, has been transferred to Martinsburg, W. Va., and assigned other duties there in the maintenance of way department of the same road.

Mr. Thomas Plunkett has been appointed special representative of the Revere Rubber Company, of Boston, Mass. The scope of his operations is not confined to any particular locality, but his headquarters are in Boston.

Mr. A. N. Willis, master mechanic of the Chicago, Burlington & Quincy at Brookfield, Mo., has been appointed superintendent of the same road, with headquarters at St. Joseph, Mo., succeeding Mr. A. T. Perkins, resigned.

Mr. A. L. Rossetter, formerly master mechanic of the Chicago, Peoria & St. Louis, has been appointed superintendent of motive power of the same road, with headquarters at Springfield, Ill., succeeding Mr. M. D. Stewart, resigned.

Mr. H. L. Leach, formerly general foreman of rolling stock and equipment of the Bangor & Aroostook, has been appointed assistant superintendent of motive power and equipment of the same road, with headquarters at Houlton, Me.

Mr. W. F. Buck, formerly master mechanic of the Atchison, Topeka & Santa Fé at Needles, Cal., has been appointed mechanical superintendent of the Eastern Grand Division of that road, with headquarters at Topeka, Kan., vice F. N. Risteen, deceased.

Mr. E. F. Needham, formerly master mechanic of the Fort Wayne division of the Wabash Railroad, has been transferred on the same road in a similar capacity to the Decatur and Springfield divisions, with office at Springfield, Ill., vice Mr. C. H. Doeblor, resigned.

Mr. W. A. George, formerly general foreman at the Needles shops, has been appointed master mechanic of the Arizona division of the Atchison, Topeka & Santa Fé Railway Company's Coast Lines, with headquarters at Needles, Cal., vice Mr. W. F. Buck, promoted.

Mr. R. K. Reading, superintendent of motive power of the Philadelphia and Erie division of the Pennsylvania, at Williamsport, Pa., has been appointed superintendent of the Buffalo and Allegheny division of the Pennsylvania, with headquarters at Buffalo, N. Y., vice Mr. H. M. Carson, promoted.

Mr. C. M. Muchnic, formerly mechanical engineer of the Denver & Rio Grande, and lately assistant to Mr. R. J. Gross, vice-president of the American Locomotive Company, has been appointed to the position of manager of the foreign department of that company, with office in New York.

Mr. L. F. Power, formerly manager of the electrical works of the Allis-

Chalmers Company in Cincinnati, who was recently promoted to the position of controller of the company, has already assumed the duties of his new office, with headquarters at the general offices of the company, Milwaukee.

Gen. Eugene Griffin, first vice-president of the General Electric Company, sailed from New York last month, on an extended trip to England and the continent, largely for rest and recreation. He is a director in the Cie Francaise Thomson-Houston and vice-chairman of the British Thomson-Houston Company, and these interests will naturally claim a portion of his time.

Mr. William F. Allen has been honored by the Belgium Government with the decoration of Chevalier of the Order of Leopold in recognition of the part he took in the seventh annual session of the International Railway Congress, held in Washington in May, 1905, and of which he was associate secretary-general and secretary of the American section. The insignia of the order was conveyed to Mr. Allen by Baron Moncheur, the Belgian Minister at Washington. The Order of Leopold was founded by Leopold the First of Belgium, the father of the present reigning sovereign. It is similar in its organization and purposes to the Legion of Honor in France. Mr. Allen is perhaps best known to our readers as secretary of the American Railway Association.

Mr. Frank P. Roesch has been appointed master mechanic of the Southern, with headquarters at Birmingham, Ala. Mr. Roesch was for ten years with the Colorado & Southern at Denver, as general traveling engineer, and afterward as master mechanic, leaving there to take the position of master mechanic of the western division of the Chicago & Alton, where he remained two years, and left to take the position of general superintendent of the Hicks Locomotive & Car Works, of Chicago, but he subsequently severed his connection with this concern to take his present position. Mr. Roesch has for many years been a valued contributor to the pages of RAILWAY AND LOCOMOTIVE ENGINEERING. He was the originator of the idea of making actual tests of locomotives on railroads for the purpose of definitely finding out, what has been called, economical train speed.

Mr. Herbert M. Carson, superintendent of motive power on the Pennsylvania at Buffalo, has been promoted to the position of assistant to the general manager, a position just created by the directors. He will conduct a cost bureau on scientific and practical lines, for the purpose of effecting economies in shop work and maintenance of way. Mr. Carson was born in Baltimore, Md., in March, 1867; graduated in mechanical engineering at Lehigh University in the

class of 1889, and entered the service of the Pennsylvania Railroad Company as an apprentice in the Altoona shops in July, 1889, serving in that capacity until February, 1893, when he was assigned to other duties. Later on he was appointed assistant road foreman of engines of the Philadelphia division in August, 1893; and afterward assistant engineer of motive power, P. R. R. division, located at Altoona, in April, 1895. He took the position of master mechanic of the Pittsburgh division in February, 1900, and in October, 1901, was appointed superintendent of motive power of the Buffalo and Allegheny Valley division, in which position he served up to the time of his promotion to the position of assistant to the general manager. Education, with practical training and experience, have fitted him for this highly important undertaking, and having been selected for it by the company he has so long and ably served, he has been exceptionally honored.

#### Obituary.

The death of Mark Markland, said to be the oldest engineer in England, is announced. He had reached the age of 86. He started railroading in 1828. He joined the Midland Company, and ultimately became locomotive superintendent, an office he held for forty-five years. It was his boast that, during his long term of office as superintendent, no engineer or fireman had lost their lives by an accident on the road.

A melancholy accident occurred recently on the Union Railroad which resulted in the death of Engineer Albert M. French. The accident was a very peculiar one. At Green Springs the road runs along the steep bluff between Kennywood Park and the river, and as the train went along, a large boulder became loosened far up the hillside, and bounding down the steep bluff, smashed through the cab window, splitting the arm rest and striking the engineer a deadly blow on the head, and when the fireman got to him he was lying in an unconscious condition. He was brought to the office of the company's physician at Munhall, and an examination revealed the fact that he was suffering from concussion of the brain. He died shortly after in the hospital. Mr. French was 35 years of age, and is survived by a wife and four children. He also has five brothers, all of whom are railroad engineers. The information which first reached this office gave the name of the railroad as the B. & O., and a brief notice of the tragic occurrence appeared in our paper last month. It happened, however, on the Union Railroad, and his untimely death is deeply felt by all who knew him.



# Old-Timer Talks No. 3



Ever see a bearing under a microscope? Well, it's just full of little hills and dales—feels smooth but it ain't.

Course, oil keeps these little projections apart, but every little while they dig into each other. Then wear occurs and energy is wasted. When you add a little DIXON'S Graphite, it spreads over the friction surfaces—a little here, more there if it's needed—until the bearing is really smooth.

Now there's as much difference



between various graphites as there is between men. Those Dixon people produce a pure, thin flake. Friction, of course, occurs only between surfaces; this thin flake covers the most surface and is therefore the most economical. Did you send for that sample No. 69-C yet?

Joseph Dixon Crucible Co.  
Jersey City, N. J.

## Dukesmith Air Brake.

The Dukesmith Air Brake Co., of Pittsburgh, Pa., has recently brought out a new straight air control valve, which is being installed on several roads, and among them the P. & L. E., one of the New York Central Lines. The illustrations and description of this valve which follow are taken from their Bulletin No. 14, which has just been issued.

Operation.—There are five positions in which the handle of the control valve may be placed, as follows: Full release position, in which all the brake cylinders and also all the auxiliary reservoirs on the locomotive are open direct to the atmosphere, thereby insuring the quickest possible release of the brakes on the locomotive; normal or running position is the second one and in this position the exhaust port of the engine triple is open to the atmosphere, so that the brakes on the locomotive and train may be operated with the engineer's automatic brake valve in the usual way, the same

as though the control valve were not on the engine; cylinder release position is the third, and in this position the cylinders on the locomotive are open direct to the atmosphere, but the auxiliary reservoir exhaust is not open, and, therefore, this position enables the engineer to reduce the brake cylinder pressure on the locomotive after an automatic service application to any desired degree without exhausting any pressure from the auxiliary reservoirs; lap position closes all ports, and this piston may be used to retain the pressure in the brake cylinders on the locomotive after either a straight air or automatic application has been made; application position is for the purpose of applying the locomotive brakes without applying the train brakes, and the locomotive brakes may be applied to any desired degree up to whatever the reducing valve in the auxiliary reservoir supply pipe is set. The reducing valve is usually set at 45 lbs. so that a full straight air application would then only give a pressure of 45 lbs. in the brake cylinders of the locomotive.

The working parts of the straight air control valve consist merely of a tapered key (or plug) contained in a suitable casing, and a handle of the ordinary type as used on brake valves generally.

A half-inch pipe connects the valve to the exhaust port of the engine

triple; a three-quarter inch pipe connects the valve directly with the brake cylinders on the engine and tender; a half-inch pipe connects the valve to the auxiliary reservoir, and in this pipe there is located at any convenient point an automatic reducing valve, which is usually set at 45 lbs.; a three-quarter inch pipe connects the valve to the auxiliary reservoir pipe of the engine and tender; the main exhaust in the control valve is not connected to any pipe. The engine and tender auxiliary reservoirs are connected with a half-inch pipe.

As only one triple valve is required on the engine and tender, there is a by-pass connection made from the train pipe to the auxiliary reservoir with a half-inch pipe, and in the by-pass there is a non-return check valve and a reducing diaphragm with a one-eighth inch opening; this by-pass enables the engine and tender auxiliary reservoirs to be charged up as quickly as though there were two triple valves; with this

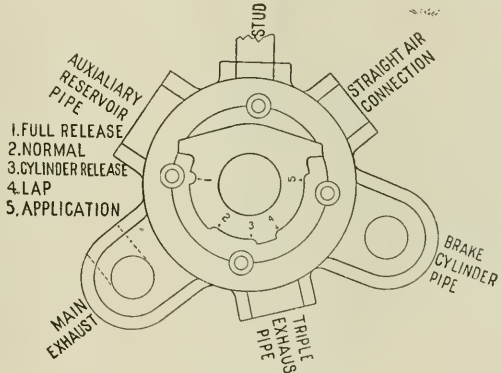

DIAGRAM SHOWING POSITIONS ON QUADRANT AND PIPE CONNECTIONS OF VALVE.

by-pass arrangement the train pipe pressure is not only free to pass through the regular feed groove in the triple, but is also free to pass into the auxiliary reservoirs by way of the check valve in the by-pass, but when a reduction of train pipe pressure is made, the check valve prevents the auxiliary pressure from flowing back into the train pipe.

In piping the straight air control valve there is a safety valve on the pipe between the brake cylinders on the engine, but this safety valve is not used when the Dukesmith automatic release signal is placed on the engine, as the release signal not only serves the same purpose of the old style safety valve, but is also a gauge, as it indicates at all times just what the pressure is in the brake cylinders.

The tender auxiliary reservoir is placed on the engine, and is piped to the engine auxiliary; there is a cut-out cock between the auxiliary reservoirs and also

on the brake cylinder pipe under the deck of the engine, so that should the tender brake rigging become defective for any reason these cut-out cocks may be closed, thereby dispensing with the brake on the tender, but leaving the brakes on the engine in full working order.

In order to take the slack of a train, a light straight air application should be made and the slack allowed to fully run up against the engine before making an automatic application, and the time required for the slack to run up depends entirely on the length of the train.

To hold the slack of a train and to prevent the engine from rolling ahead and pulling out the drawheads, it is necessary that the handle of the straight air control valve be left on lap position while the train brakes are being released, and until the train comes to a full stop, and

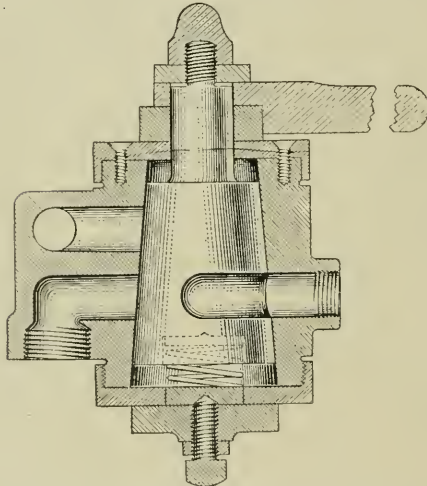

VERTICAL SECTIONAL VIEW OF STRAIGHT AIR CONTROL VALVE WITH HANDLE IN APPLICATION POSITION.

should the cylinder leathers on the locomotive be leaky it is then necessary to make a straight air application while the train brakes are being released, for should the pressure be allowed to leak from the brake cylinders on the engine while the brakes on a long train are being released the engine would naturally roll ahead, which would not only cause a heavy jerk, but is likely to pull out a drawhead.

When starting a train which has been kept bunched by the straight air control valve, the engineer should be careful to give the engine just enough steam to stretch the train gradually, and thereby avoid shocks and jerks.

In making a slow-down it will be found that in the great majority of cases it is not necessary to use the automatic brake valve, as the brakes on the engine and tender which are operated by the

straight air control valve will be sufficient to bring the train to the desired slow speed. While this method of operating not only saves the pump, which means the saving of fuel, but it leaves the automatic brakes ready for a full emergency application, should it be found necessary to quickly stop the train, when only a slow-down was intended.

Whenever the engineer leaves the engine, or when he is working under the engine, he should be careful to place the handle of the straight air control valve in application position and leave it there until he is again ready to go, for if he should make a straight air application and bring the handle back to lap, the air in the brake cylinders might leak out if the leathers were defective, whereas, if he leaves the handle in application position, then there is no danger whatever of the engine moving so long as there is any air in the main reservoir or train pipe.

In order to reduce the brake pressure on the locomotive without releasing the brakes on the train, it is merely necessary to place the handle of the straight air control valve in cylinder release position long enough to allow the cylinder pressure to exhaust down to whatever point is desired (it can all be exhausted in this position if necessary), after exhausting the desired amount of pressure the handle should then be placed in lap position.

When a hose bursts, or when an undesired emergency application has been made, the handle of the straight air control valve should be at once thrown to full release position, and left there until the engine and tender brakes are entirely released, which requires about ten seconds.

#### Pipe Covering Contract.

The H. W. Johns-Manville Company, of New York, through their Chicago branch, have just filled a large order for the installation of Fire Felt Pipe and Boiler Covering in the new plant of Sears, Roebuck & Co., of Chicago. The work involved an expenditure of several thousand dollars. This covering is fire-proof, elastic, light in weight, and unaffected by expansion or contraction of the metal pipes. This is but one of the many large contracts which this company have recently executed. In addition to being extensive manufacturers of Asbestos Coverings, Packings and Roofing Specialties, the Company manufactures Electrical Supplies.

## The Best and Cheapest Books for Railroad Men

### AIR BRAKE CATECHISM Price, \$2<sup>00</sup>

By Robert H. Blackall. 20th Edition. Contains 1500 Questions and their Answers on the Westinghouse Air Brake, which are strictly up-to-date. Includes two large Westinghouse Air Brake Educational Charts printed in colors. Gives the necessary information to enable a railroad man to pass a thoroughly satisfactory examination on the subject of Air Brakes. The author's many years' experience as Air Brake Inspector and Instructor enables him to know at once how to treat the subject in a plain, practical manner. Endorsed and used by Air Brake Instructors and Examiners on nearly every railroad in the United States. The standard and only complete work on the subject. 312 pages.

### LOCOMOTIVE BREAKDOWNS AND THEIR REMEDIES Price, \$1<sup>50</sup>

By Geo. L. Fowler. Just issued. Tells how and what to do in case of an accident or breakdown on the road; includes special chapters on Compound Locomotives. Better procure a copy, as it contains 800 Questions and their Answers on Accidents and Breakdowns.

### LOCOMOTIVE CATECHISM Price, \$2<sup>00</sup>

By Robert Grimshaw. 23d Edition. Is right up-to-date and contains twelve large Folding Plates and 1600 Questions and Answers on How to Run a Locomotive. The Standard Book on the subject, being written in plain language and free from mathematical formulæ and complex problems.

### NEW YORK AIR BRAKE CATECHISM Price, \$1<sup>00</sup>

By Robert H. Blackall. The only complete treatise on the New York Air Brake and Air Signaling Apparatus, giving a detailed description of all the parts, their operation, trouble, and the methods of locating and remedying the same. 250 pages.

### COMBUSTION OF COAL AND THE PREVENTION OF SMOKE Price, \$1<sup>50</sup>

By Wm. M. Borr. Contains over 800 Questions and their Answers on the Science of Steam Making.

### AIR BRAKE CHARTS Price, 50c.

Show the Westinghouse Equipment in ten colors, including freight and passenger engine. Every railroad man should possess these charts at this low price.

A Special Circular of any of these books sent on request. Any of these books sent pre-paid on receipt of price.

Agents Wanted at Every Terminal. Write for our special terms. You can make equal to a month's pay selling our books on the side

The Norman W. Henley Pub. Co.

132 Nassau Street, New York, U. S. A.

# "J.-M."

## LOCOMOTIVE LAGGING

"J.-M." 85% MAGNESIA

The high heat resisting properties of this lagging, coupled with its well known insulating value, make it unequalled as a locomotive boiler covering. It is light, easily applied and very durable. Formed in blocks 36 inches long by 6 inches wide, of the desired thickness, curved to fit the radii of locomotive boilers. Shows up best under the most severe tests.

## VULCABESTON PUMP PACKING

Is the most efficient, durable and economical packing made. The least friction, the longest service and the greatest satisfaction are guaranteed by its use. It does not char or blow out and is used exclusively by many of the most important railroads in the country.

WRITE NEAREST BRANCH  
FOR RAILROAD CATALOGUE

### H. W. JOHNS-MANVILLE CO.

Manufacturers of Asbestos and Magnesia Products Electrical Insulating Materials "Noark" Fuse Devices, Electrical Railway Supplies, etc.

NEW YORK ST. LOUIS KANSAS CITY  
MILWAUKEE PITTSBURG MINNEAPOLIS  
CHICAGO CLEVELAND LITTLE ROCK  
PHILADELPHIA NEW ORLEANS  
BOSTON SAN FRANCISCO  
LOS ANGELES SEATTLE  
LONDON

### Machine Blacksmith.

Everybody has heard of a railroad excavating machine being called a Steam Irishman, but the bulldozer and the forging machine have not quite so often been called the machine blacksmith, and yet, in a sense, the name applies in the one case as well as in the other. One thing, however, is true of steam shovels and power operated tools of all kinds, and that is, they must have something to work on. To economically operate a shop, whether it be a place where forgings are made or some other kind of establishment, it is necessary that the tools be kept busy. That is the fundamental requirement.

In a modern tool-equipped blacksmith shop, the limit of the output has become almost entirely the measure of the ability to heat material. The modern smithy is very different from the shop in which forging was done some years ago. In the first place, it does not take up as much space as its forerunner did. This does not mean that the modern blacksmith shop is smaller by actual measurement than it was in times past. It is often larger than the older shop was, but it is smaller in proportion to the amount of work turned out, or, in a word, it is more compact.

It is, at the present time, generally placed with reference to the scheme of things, so that the raw material coming to it may be easily and promptly delivered, and that, having once entered the smith's shops, material will not have to double on its tracks, so to speak, but will move forward in orderly fashion through the forming and the finishing processes. There are fewer fires and more machines and more furnaces in such a shop to-day, and the cranes, hoists, travelers, etc., are much more in evidence than they formerly were. The shop is cleaner and brighter, and there is possibly a more business-like appearance to the whole place. This is the picture of the modern shop, and the output of the shop rests on the ability to heat the material to be worked, and to keep the machines busy.

The modern smithy is something more than a mere blacksmith's adjunct to the railway repair plant. It has become to a great extent a manufacturing establishment, and when rightly and economically administered, the results obtained should be fairly comparable to those of an outside business concern; and though no railroad shop should be expected to compete with the highly specialized methods of commercial enterprises, yet the standard by which railroad-work is judged at the present time differs rather in degree than in kind. The modern railroad smith's shop helps the weaker points on the line, and its product is distributed

where the time element in delivery is important.

Speaking some time ago on the subject of shop output being largely determined by the ability to heat material, Mr. John McNally, foreman blacksmith of the Chicago & North-Western, said, in substance, that "When the larger part of our output was the result of hand labor, the heating of the material was a simple question, the quality of heat being the only consideration necessary, as any of the coal or coke fires could easily supply sufficient working material. In looking for a method of increasing heating facilities for machine work, petroleum, so bountifully supplied by nature, was naturally a great attraction. The important points to consider have been quality and quantity of heat possible of production, cost, and the best method of producing it, and what should, but has not always been, considered, the conditions under which furnace men are subjected in handling the material. Crude petroleum, or fuel oil, which is commonly used, has a very



AVENAL STATION ON THE CARTAGENA-MAGDELENA RAILWAY.

high heating efficiency, containing as it does from 20,000 to 22,000 heat units per pound, as compared with from 12,000 to 14,000 per pound, for coal. It is capable of practically perfect combustion, leaving no ash, and, when properly handled, producing no smoke. The quality of the heat is as satisfactory as coal or coke, if generated in the proper manner.

"The mere act of burning oil is a simple one, but the burning of oil and producing a proper flame is a very particular process. Atomizing the oil with air or steam under high pressure through variously constructed burners, and burning the resulting mixture by depending upon the heat of the furnace to keep up the combustion, is a method commonly followed. This high pressure or atomizer system almost invariably produces an oxidizing flame, resulting in burning the material. Bridge walls and other arrangements somewhat help combustion, but do not overcome the action of the oxidizing flame. Owing to our familiarity with compressed air, due to its general use in

our shops, few of us appreciate the high cost of producing it, and its influence in increasing the cost of heating where it is used as an atomizing agent in oil furnaces.

"These several objections to the atomizer system were appreciated in the early 90's by a brother railroad man, and to his thorough study of the subject and his years of experimental work we are indebted for ideas which have been developed into the low pressure and economical process known by his name to-day. He eliminated expensive compressed air and substituted the ordinary low pressure fan blast used in our open forges, on the theory that volume, and not pressure, was necessary for the successful burning of oil. With a low pressure of only a few ounces he fortunately could not successfully atomize, so he was obliged to work on other lines, resulting in a process which first burned the oil in a small amount of air, thereby breaking it up into the hydrocarbons, then with the heat of the subsequent combustion breaking these hydrocarbons down to gases, such as marsh gas, carbon monoxide, free hydrogen, etc., and finally supplying these gases with a second and larger volume of air and burning them completely. All of this was done in a small and independent combustion chamber, the hot gases only being forced into the heating area of the furnace.

"This process resulted in a very perfect combustion of the oil at a low cost of operation, and supplied a soft, dry heat to the furnaces. The process we are using at the North-Western shops overcomes this difficulty by means of the secondary air supply. Having perfected the combustion, ensuring a maximum amount of heat from the least bulk of oil, the furnace design and construction, for the purpose of ensuring the saving and utilization of this heat, is equally important. A pound of oil contains a given amount of heat, all of which is made available with perfect combustion, but a poorly designed and constructed furnace, even if it is apparently doing satisfactory work, may be losing enough of this heat to make the cost of the operation prohibitive."

It appears to us that another very important factor in securing the most satisfactory results from a blacksmith shop equipped with expensive forging machinery, may be comprehended in the expression, "Help and encourage the man in charge." To do this it is necessary to let him have suitable appliances for doing the work expected of him, and to let him have his ideas and designs promptly worked out, dies made and delivered to him in a reasonable time.

There are many good ideas or designs approved by the general foreman which

are not only figuratively but literally "hung up" when the sketch representing them is spiked on the "unfinished business" hook of a busy machine shop, because it is for shop equipment as distinguished from railroad repair work, and does not exactly count as machine shop output. When looking at the whole question broadly and considering the interdependence of one shop or one department on another, it is not stretching the words of St. Paul too far to apply them here, for he says, "And whether one member suffer, all the members suffer with it; or one member be honored, all the members rejoice with it."

A hard headed old Pittsburgh manufacturer who had made his fortune "with his coat off," as he expresses it, was induced by his daughters to accompany them to a Wagner concert, the first he had ever attended. The next day he happened to meet an acquaintance who had seen him the night before. The acquaintance said: "I suppose you enjoyed the concert last night, Mr. Brown?" "Yes; it took me back to the days of my youth," the old man said, with a reminiscent sigh. "Ah, yes; summer days in the country, girl in a lawn dress, birds singing, and all that sort of thing." "No; the days when I worked in a boiler shop in Scranton."

Our correspondence school questions and answers, second series, this month deal with the subject of lubricators, and in this connection we may call attention to the two publications got out by the Detroit Lubricator Company, of Detroit, Mich. One of these is their lubricator catalogue of 1906, and deals with the products of that concern, which include plain lubricators, brass and glass oilers, brass and glass oil pumps; multiple oilers, oiling devices, grease cups, boiler oil injectors, low water indicators, throttle valves, globe valves, and also steam and hot water radiator valves. This is well illustrated and the action of each piece of apparatus is fully described in the letter press. The other publication contains some facts about the Detroit Locomotive Lubricators of the type represented by the "Detroit" No. 21. This is also well illustrated, and there is a lot of information contained in small compass. It is in size suitable to be easily carried and the idea in getting it out in this form probably is that the book can be carried in the pocket so that the information may be readily got into a man's head. We would advise those who are interested in the subject, or those who have to do with the use or care of lubricators to write direct to the company and ask for a copy of both.

# GOLD Car Heating and Lighting Co.

Manufacturers of

**ELECTRIC,  
STEAM AND  
HOT WATER  
APPARATUS  
FOR RAILWAY CARS**

**EDISON  
STORAGE  
BATTERY  
FOR RAILWAY CAR  
LIGHTING**

Largest Manufacturers in the World  
of Car Heating Apparatus

Catalogues and Circulars  
cheerfully furnished

Main Office, Whitehall Bldg.  
17 BATTERY PLACE  
NEW YORK

# Homestead Valves

Straightway, Three-way and Four-way, and

# Homestead Locking Cocks

Are Famous the World Over

They cost more, but are worth very much more than other makes. You try them and see.

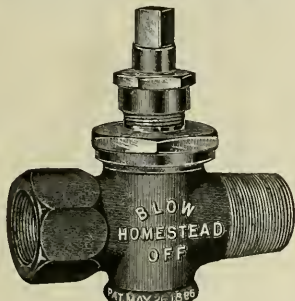

Brass, 1 1/4 in., \$6.00 net

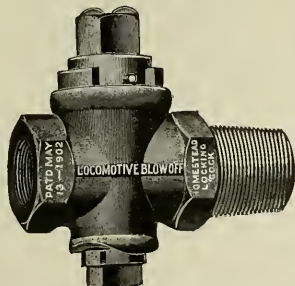

Iron Body, Brass Plug, 1 1/4 in., \$4.00 net

## Homestead Valve Mfg. Co.

WORKS, HOMESTEAD, PA. PITTSBURG, PA.

### Flat Car of Unique Design.

A specially designed steel flat car of 125,000 lbs. capacity is used by the General Electric Company, of Schenectady, N. Y., for the transportation of generator armatures and revolving fields for electric machinery. The car which we illustrate is one of a series made of structural steel shapes and heavy plates. It has no center sills, and the space between the body bolsters is made into a deep semi-circular well in which the pieces to be carried are slung.

The side sills are I-beams about 16 ins. deep and 32 ft. long, and the design is such that the car embodies the principles of bridge construction as far as carrying the load is concerned, but the car has to stand a kind of usage which bridges are not called upon to sustain, and that is the pulling and buffing

placed, which receive the ends of the shaft of the piece to be carried. The car thus becomes practically equivalent to a pair of beams loaded at the center and supported near the ends, and the whole is mounted on a pair of heavy arch bar trucks.

There is a brake mast at each end, so that in case one of them should be interfered with at any time by the load, the other would be available. Our illustration shows a man standing at one end of the car, and a good idea of the car's height as it stands without load can be had by comparison with the stature of the standard railroader shown. The fact that the General Electric Company has found it necessary to build a number of these cars for the transportation of its product is a very good evidence of the prosperity of the

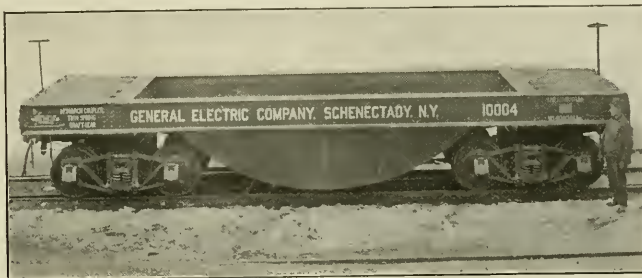

STEEL FLAT CAR FOR SPECIAL PURPOSE.

strains and shocks to which all railway vehicles are subjected in service.

The height of the car above rail level is 5 ft. 6 ins., and its width over sills is 10 ft. The well measures 17 ft. long by 8 ft. wide, and its lowest point comes down close to the rail. The plates of the well, however, do not support the load, but altogether the well forms a convenient receptacle and prevents the loss of any small parts should they shake loose or drop from the armature or field magnets when being carried on the car.

The tare weight of the car is 40,900 lbs., and there are short center sills at each end, extending from the body bolsters to the end sills. The construction of the body bolsters is such that they practically form box girders across the car and are of unusual depth. The spaces between the side sills and the short center sills are boxed in so as to form receptacles in which small parts can be packed for shipment. These receptacles are covered with trapdoors, and when shut down form limited deck areas at each end of the car.

The method of shipment of the circular pieces of electrical machinery for which the car is intended, is to place a pair of blocks, one on each side sill, about the center of the car, and upon these two temporary trunnions are

company itself and of the popularity of the electrical machinery and equipment as built at their Schenectady shops.

The National Metallic Packing Co., of Oberlin, Ohio, have placed on the market a metallic packing which they hope will find favor with the various steam railroads of the country. The company have quite a number of the large lake vessels equipped with the packing, also several electric light plants and stationary engines. They have lately gone into the locomotive field, and are now demonstrating the qualities of their packing on the Baltimore & Ohio, the Pennsylvania Lines, and the Pittsburgh & Lake Erie railroads. The packing is milled from the best grade of charcoal iron, having a square and tangent cut interlocking, thus doing away with the use of dowel pins. When in use it glazes the rod and adapts itself to the shape of the rod, whether the latter be perfectly round or not, and it is said to be steam tight under all circumstances. Being in sections, it is not necessary to remove the rod to apply the packing; it can be applied to any engine in a few minutes. If the guides are out of line it does not affect the working of the packing, as it conforms itself to any irregularities in the piston rod. The

## American Locomotive Sander Company

13th & Willow Sts., Philadelphia, Pa.

Proprietors and Manufacturers

LEACH, SHERRILL, DEAN, HOUSTON, "SHE" and CURTIS SANDERS

### THE ROBERT W. HUNT & CO.

Bureau of Inspection, Tests and Consultation,  
1137 THE ROOKERY, CHICAGO.  
64 Broadway, New York. Park Building, Pittsburgh.  
31 Norfolk House, London, Eng.

Inspection of Steel Rails, Splice Bars, Railroad Cars, Wheels, Axles, etc. CHEMICAL LABORATORY—Analysis of Ores, Iron, Steel, Oils, Water, etc. PHYSICAL LABORATORY—Test of Metals, Drop and Pulling Test of Couplers, Draw Bars, etc.  
Efficiency Tests of Boilers, Engines and Locomotives.

packing will suit either compound or simple engines of any design, and with ordinary care will last on either valve stem or piston rods as long as the engine is out of the shop. The company guarantee the packing on a stationary or marine engine for three years, and on a locomotive for the time between heavy shop repairs, taking the mileage set by the mechanical departments of the different roads as a fair basis. For information as to cost of application and price list, write to Mr. W. P. Caruthers, Oberlin, O., or to Mr. P. Coniff, Holloway, O.

**Sure Thing.**

There is a wheel carriage or truck used in the car shop of the Pennsylvania Lines West at Pittsburgh, Pa. It is intended for the transport of an ordinary pair of car wheels and axle, and it does its work with satisfaction to itself, the wheels, and everybody concerned.

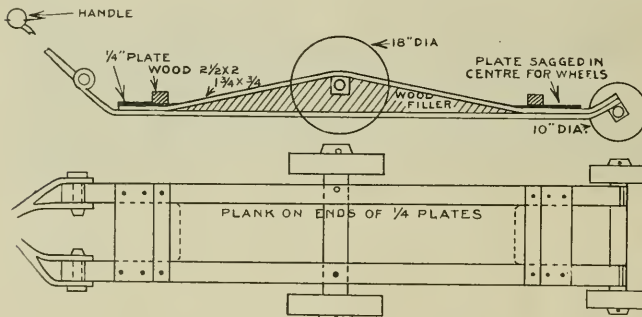

CAR OR COACH-WHEEL CARRIAGE FOR THE SHOP.

It consists of a frame made of two parallel bars of flat iron, and they are trussed by a bar which runs up to the level of the axle of the little carriage. The main wheels of the carriage are situated in the center of the vehicle, and have 3-in. flat treads, and there are a small pair at one end, which are intended to keep the whole thing steady when being loaded.

There are a pair of 1/4 in. plates fastened to the frames, one at each end, and these plates are sagged down in the center to about the same curve as a pair of 33 in. wheels, so that when the car wheels are on the carriage they will stay where they have been put. Two blocks of wood about 2 1/2 x 2 are bolted along one edge of these sagged plates at each end, and these blocks are intended for guides or to prevent the car wheels from being driven off the car endwise. As the carriage frame is only a few inches from the ground, the wheels to be carried are rolled up a pair of wooden wedges and are placed on the short sagged plates at the ends, the

axle of the car wheels passing easily over the top of the wheels of the carriage. A plank of wood forms a sort of floor for the carriage, and upon this plank the wooden wedges used in loading are conveniently carried. The plank rests on the inside edges of the sagged plates. When a pair of car wheels is being carried, the whole thing balances about the center wheels, like a hansom cab.

The vehicle has, however, to be propelled by man power, and a handle is provided so as to give the workman something to catch on to. This carriage is not an automobile, and does not set up to be one, so that the man in charge does not have to lie on his back underneath it for half an hour at a time, soaked with gasoline, nor does he have to work away in that awkward position with a sewing machine wrench to get it in working order. He just grasps the handle as if he knew what he was about and walks off with it, and

**Locomotive Blow-Off Plug Valves**

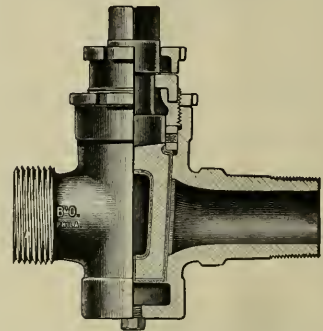

Fig. 9.

All Brass, extra heavy, with Cased Plug. For 250 lbs. pressure. Made with Draining Plug to prevent freezing.

**Locomotive Gauge Cocks**

For High Pressure

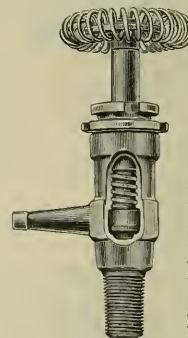

Fig 23, with Wheel.

Bordo Self-Grinding Gauge Cocks, made with renewable Hard Bronze Disc. Opened and closed with a quarter turn. Guaranteed Steam tight under the most exacting conditions. Shanks Threaded to specifications for Locomotives.

**Swing-Joints and Pipe Attachment**



Fig. 33.

May be applied between Locomotive and Tender. These Swing-Joints are suitable for Steam, Gas, Air, Water or Oil.

Complete Booklet on Application

**L. J. BORDO CO.**  
PHILADELPHIA, PA.

the pair of car or coach wheels on the carriage just follows him about the shop like Mary's little lamb.

There is a book of instructions just out, and it is issued by the Smooth-On Company, of Jersey City, N. J. It is, in fact, their illustrated catalogue No. 5, and it tells about smooth-on iron cements, smooth-on sheet packing, smooth-on corrugated steel gaskets and shows when, where and how to use them. We say shows, because the little book is well illustrated and although the letter press explains all about the uses of the products of this company, the illustrations would suit a man from Missouri, because they show him how. There are 92 pages and they contain directions as to the way to apply and use Smooth-On in all its forms. There is a table at the end of the book giving the prices and sizes of Smooth-On corrugated steel gaskets coated with Smooth-On iron elastic cement, and a few blank pages are bound in, which are available for notes and memoranda. The company

# SPANGENBERG'S STEAM AND ELECTRICAL ENGINEERING

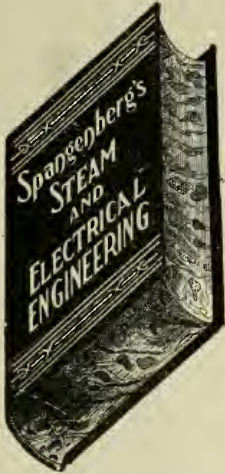

**B**RINGS YOU A KNOWLEDGE OF steam and electrical engineering that you could never gain in practice in a hundred years. The matter is plainly written, questions are asked and answered. The things that have to do with your advancement are properly treated and the cost is such that you shouldn't hesitate a minute in getting a copy. It has 672 pages, 618 illustrations and comes to you post-paid for \$3.50. 54-page booklet free.

**GEO. A. ZELLER**  
Publisher

19 So. Fourth St. St. Louis Mo

will send a copy of this little book to any engineer who writes to them and states the name of his employer.

### Christian Science and a Claim.

A queer "Christian Science" story—queer not because it reveals a new phase of Eddyocy but because it causes amusement instead of disgust or indignation—comes from the State of Texas. It is related that a Collins county farmer recently brought suit against the Houston & Texas Railway because an encounter between one of its trains and his team of horses had resulted in fatal injuries to the latter. The case came to trial, and the farmer made out an extremely good claim for damages entirely consolatory for his loss, but at the last moment, when the minds of the farmer jurymen had evidently been fully made up, the company's attorney thought to ask the plaintiff what efforts he had made to heal the injuries of which his horses died. The farmer's dream of damages then dissolved, for he announced that, being a consistent "Christian Scientist," he had done absolutely nothing for the suffering beasts except to think hard that there was nothing the matter with them. The railroad attorney, a wise man after his kind, rested his case then and there, and the jurymen brought in a verdict for the company after deliberations much too short for consideration of the rather interesting question whether the horses would not have died of their wounds even if their owner had been sane enough to call in a veterinary surgeon or do what he could for them himself. And, indeed, the question is more interesting than important, for it involved the proving by the farmer of an utterly impossible negative—one which, with his crazy notions, he would not even have attempted. As the horses had not been instantly killed, in all probability there was a chance of saving their lives, and he couldn't have argued that chance away if he had tried.—New York Times.

(Yale & Towne Mfg. Co.), Chas. N. Manfred (Johns-Manville Co.) and H. H. Kress (A. S. Cameron Steam Pump Works).

### Band Rip and Resaw.

Our illustration is of a combination bandsaw that it an entirely new departure in this line of machinery. This machine is designed for those who rip and resaw but have not sufficient work to keep separate band machines busy. This saw can be used instead of several circular saws. There is consequently a saving in kerf effected with much greater safety for the operator.

The makers of this machine claim that it does both ripping and resawing equally as well as the separate machines could do it, and it embodies every improvement which has been embodied in their other saws.

It is by an ingenious construction of the table that this machine has been made capable of performing both operations. The table is made in two parts, the half

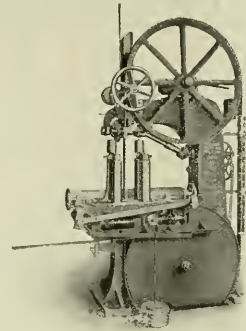

BAND RIP AND RESAW

carrying the resaw rolls being quickly reversible so that the resaw rolls may be turned up when resawing is required, and turned down to form a clear table when the operator wishes to rip.

By the use of a patent straining device the tension is kept uniform at all times and very thin blades may be run with absolute safety. The construction is simple throughout and one man can make the necessary change from rip to resaw or vice versa very quickly and easily.

This machine rips 24 ins. between the saw and the fence and up to 18 ins. thick, either straight or bevel, and resaws 18 by 8 ins. The illustration shows the machine as a resaw. Write direct to the J. A. Fay & Egan Co., Cincinnati, Ohio, for a large illustrated circular which they issue showing the machine as a rip saw also. It gives full and complete description and may be obtained for the asking.

### Officers of the T. P. A.

At the second annual meeting and Banquet of the Technical Publicity Association, held Thursday, April 5, at the Aldine Association, New York, the following officers were elected: President, F. H. Gale (General Electric Co.); first vice-president, H. M. Cleaver (Niles-Bement-Pond Co.); second vice-president, C. B. Morse (Ingersoll-Rand Co.); secretary, Rodman Gilder (Crocker-Wheeler Company); treasurer, H. M. Davis (Sprague Electric Co.); members of executive committee, Robt. L. Winkley (Pope Mfg. Co.) and G. M. Basford (American Locomotive Works); members election committee, C. W. Beaver

# Patents.

GEO. P. WHITTLESEY

MCGILL BUILDING WASHINGTON, D. C.

Terms Reasonable. Pamphlet Sent

# Molding Machines

Vertical Vibration. Power Draft

ALL KINDS OF MACHINES

THE E. H. MUMFORD CO.

17th & Callowhill Streets, PHILADELPHIA, PA.  
J. W. JACKMAN & Co., Ltd., 29 Victoria St., London, S. W.

### Portable Milling Machine.

Our illustration shows a special portable milling machine which has recently been made by H. B. Underwood & Co., of Philadelphia. This portable milling machine is the outgrowth of a temporary rig that this company were forced to make to do some work on a large machine in a stated time and with the machine in place, and from that the idea has been elaborated on from time to time until the apparatus shown has become one of their special tools. The portable milling machine has been designed for straight line work up to 8 ft. long, with a number of surfaces in line but on dif-

cussion and comes into popular use. Among railroad men the difficulty is to keep abreast of the thronging improvements that mark the rapid development of the mechanical appliances used on railways.

Right here, RAILWAY AND LOCOMOTIVE ENGINEERING supplies the necessary adjunct. Its pages are filled with the expression of the best thoughts of the leading railroad men of our time. It has met the universal approval of the leading railway men throughout the world. The price, \$2 a year, places it within the reach of every railroad employee.

"Twentieth Century Locomotives,"

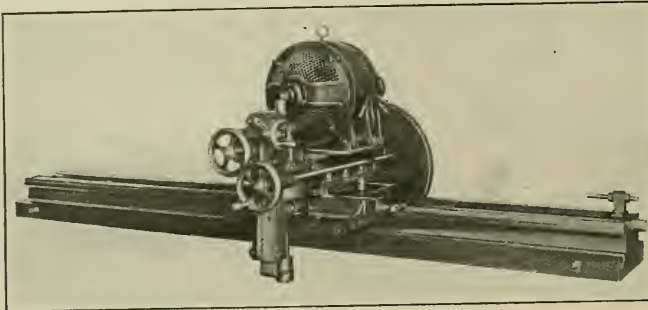

PORTABLE MILLING MACHINE FOR SHOP USE

ferent planes. The tool being motor driven, allows it to be taken to the work, which is often of such a character that no machine tool built could do as this portable appliance is required to do. Work can be done with it after all the parts have been assembled. The carriage has a travel of 8 ft., with automatic feed; the cross slide has a travel of 12 ins., and it has hand feed. The vertical spindle can travel up and down 10 ins. The spindle has a taper hole to receive the taper shank mills. The bed is mounted on a sub-base, allowing accurate adjustment by set screws screwing up against taper space pieces, thus securely holding the two beds as solid as though they were in one piece. This sub-base has long slots and projections for securing the tool to the work by clamps or bolts. The tool is a very useful and ingenious contrivance, and the company will be happy to give any further information concerning it and the work it will do, if application is made to them.

#### Science Is Truth.

The celebrated saying of Pascal, that what is true on one side of the Pyrenees is false on the other, is a just and proper satire on matters of political or other speculative opinion. In matters of science, however, it does not apply. In mechanism, particularly, every advance made passes outside the province of dis-

Angus Sinclair Co., deals comprehensively with the design, construction, repairing and operating of locomotives and railway machinery. First principles are explained. Steam and motive power is dealt with; workshop operations described, valve motion, care and management of locomotive boilers, operating locomotives, road repairs to engines, blows, pounds in simple and compound engines; how to calculate power, train resistance, resistances on grades, etc. Shop tools explained. Shop recipes, definitions of technical terms, tables, etc. Descriptions and dimensions of the various types of standard locomotives. The book is well and clearly illustrated and is thoroughly up to date in all particulars, fully indexed. Price, \$3.00.

"Locomotive Engine Running and Management," by Angus Sinclair, is an old and universal favorite. A well-known general manager remarked in a meeting of railroad men lately, "I attribute much of my success in life to the inspiration of that book. It was my pocket companion for years." Price, \$2.00.

"Practical Shop Talks." Colvin. This is a very helpful book, combining instruction with amusement. It is a particularly useful book to the young mechanic. It has a stimulating effect in inducing him to study his business. We sell it for 50 cents.

# Tate Flexible Staybolt

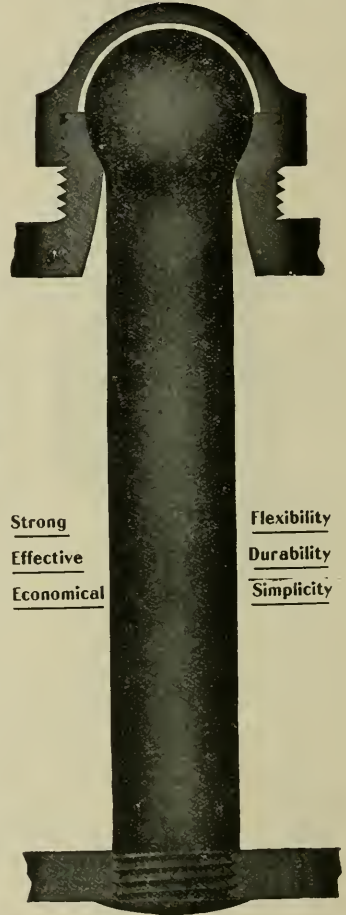

Strong

Effective

Economical

Flexibility

Durability

Simplicity

Holds firebox sheets securely together, and accommodates itself to the unequal expansion of the plates.

## FLANNERY BOLT COMPANY

PITTSBURG, PA., U. S. A.

Suite 308, Frick Bldg.

B. E. D. STAFFORD, - - General Manager

Write us for Reference Book



# THE UNION SWITCH & SIGNAL CO.

Consulting and Manufacturing  
Signal Engineers

Automatic Block Signals—Electric  
and Electro-Pneumatic

Interlocking—Electric, Electro-Pneumatic  
and Mechanical

Electric Train Staff Apparatus

GENERAL OFFICES AND WORKS AT  
SWISSVALE, PA.

DISTRICT OFFICES:

New York: 143 Liberty Street  
Chicago: Monadnock Block  
St. Louis: Frisco Building

## QUINCY, MANCHESTER, SARGENT CO.

Successing: O & C COMPANY,  
RAILWAY APPLIANCES CO.,  
FREDRICK & AYER CO.

SOLE SALE AGENT  
ELASTIC NUT OR BOLT CO.

Old Colony Building  
CHICAGO

114 Liberty Street  
NEW YORK

Factories: Plainfield, N. J.  
Chicago Heights, Ill.  
Milwaukee, Wis.

Manufacturers of

## Railway Machinery and Appliances

# PATENTS

Our Hand Book on Patents, Trade-Marks,  
etc., sent free. Patents procured through  
Munn & Co. receive free notice in the

SCIENTIFIC AMERICAN

MUNN & CO., 361 Broadway, N. Y.  
BRANCH OFFICE: 625 F St., Washington, D.C.

"Examination Questions for Promotion." Thompson. This book is used by many master mechanics and traveling engineers in the examination of firemen for promotion and of engineers likely to be hired. It contains in small compass a large amount of information about the locomotive. Convenient pocket size. We cordially recommend this book. It sells for 75 cents.

The 1904 Air Brake Catechism. Conger. Convenient size, 202 pages, well illustrated. Up to date information concerning the whole air brake problem, in question and answer form. Instructs on the operation of the Westinghouse and the New York Air Brakes, and has a list of examination questions for engineers and trainmen. Bound only in cloth. Price, \$1.00.

"Compound Locomotives." Colvin. This book instructs a man so that he will understand the construction and operation of a compound locomotive as well as he now understands a simple

contains several chapters on oil burning locomotives. Price, 50 cents.

"Locomotive Link Motion." Halsey. Any person who gives a little study to this book ceases to find link motion a puzzle. Explains about valves and valve motion in plain language. Price, \$1.00.

### Clearing for a Terminal.

Approaching the brink of the deep and wide excavation that is being made for the Pennsylvania Railroad tunnel terminal in the heart of New York City it reminds us of a miniature copy of the Grand cañon of Colorado. The magnitude of the artificial gorge is so far beyond anything of the kind usually seen anywhere in cities that it is not to be wondered at that thousands of idle spectators throng around the dizzy brink gazing for hours at the spectacle. Hills and valleys and lakes and rivers are scattered in natural profusion over the face of the miniature abyss. There are



EXCAVATING FOR THE PENNSYLVANIA TERMINAL, NEW YORK CITY.

engine. Tells all about running, breakdowns and repairs. Convenient pocket size, bound in leather, \$1.00.

"Catechism of the Steam Plant." Hemenway. Contains information that will enable a man to take out a license to run a stationary engine. Tells about boilers, heating surface, horse power, condensers, feed water heaters, air pumps, engines, strength of boilers, testing boiler performances, etc., etc. This is only a partial list of its contents. It is in the question and answer style. 128 pages. Pocket size, 50 cents.

"Care and Management of Locomotive Boilers." Raps. This is a book that ought to be in the hands of every person who is in any way interested in keeping boilers in safe working order. Written by a foreman boilermaker. Also

railways above railways, with a score of locomotives and hundreds of cars in constant operation. A dozen steam shovels are scooping up the loose material in titanic shovelfuls. Machines are cutting long narrow grooves in the solid rocks. Hundreds of workmen, busy as ants, are clustering here and there on the sloping precipices. Steam whistles are shrieking and voices are calling from brink to brink as the long trains of cars move away to a bend in the distant river that is being transformed into a system of docks.

From the bottom of this artificial gorge ordinary houses seem towering aloft like the Capitol at Washington. The distant steeples seem to touch the clouds. We are among rocks of every variety. Deep down there is a coarse

kind of marble, hard and rough as granite. Higher up are layers of brown conglomerate mixed with coprolites hard as flint and polished in the wash of primeval seas. We were reflecting on the involved cycles of ages that had elapsed since one kind of rock was molten fire and the other loose sand, when we were suddenly called back to the twentieth century with cries of "skiddo—23—beat it," and other unintelligible jargon. It was a laborer waving a red flag. A blast was to be set off and it was high time for us to stand back a little. Around the corner a group of Italian laborers were upon their bended knees with their swarthy faces half hidden in their hats, their lips silently moving as if calling on St. Anthony of Padua, when presently a piece of the cliff about the size of a locomotive leaped into the air accompanied with a muffled crash that shook the neighboring steeples. The splintered rocks had scarcely settled on the ground when a great crane swung its mighty arm around and a train of cars backed into place and the steam chisels and drills and shovels were going again at double speed, as if to make up for lost time.

Something of the magnificent massiveness of the contemplated structure can be already learned from the finished walls that flank portions of the sides of the excavation. These walls are about sixty feet in height with projecting bastions sloping inwards like the bold battlements of some frowning fortification.

Outdoor Cranes, is the title of a little pamphlet which has recently come to our office. It is not, however, a treatise on a particular species of birds, as one might perhaps at first think, on reflecting that cranes are usually to be found outdoors. It is, in fact, devoted to the consideration of that species of cranes which inhabit stone yards, freight yards, lumber and all kinds of storage yards, and the cranes themselves come from the Philadelphia works of the Niles-Bement-Pond Company, whose New York office is at 111 Broadway. These electric traveling cranes are for outdoor use and have a span of 50, 60, 80 or 90 ft., as required, and they cover the ground over which they fly in a most thorough manner; in fact, the use of a crane of this kind makes every inch of space below it available for storage. The American Locomotive Company uses one 60 ft. span at their Allegheny shops, and the crane lays down and picks up boiler plate with the utmost facility. The pamphlet is full of excellent half-tones and these tell the story, which is supplemented by the letter press given at the beginning of the little book. An interesting example of what large outdoor crane work really amounts to is

shown by representation of a 15 ton electric traveling gantry crane, 70 ft. span, with cantilever extensions which give a total trolley travel of 104 ft. The outdoor crane is the most expeditious method of utilizing yard space and if you want to get a good idea of the state of the art, write to the company direct and ask for one of these illustrated catalogues.

#### Filling Boiler While Being Towed. Editor:

I notice in April number of RAILWAY AND LOCOMOTIVE ENGINEERING, on page 153, some notes from A. J. H., Alena, Ark., in regard to filling boiler while being towed. He says one important thing is left out. I will answer it as follows: The important thing is, to plug up the exhaust nozzles.

E. B. THRALL.

Plattsmouth, Neb.

#### Oldest Tree in the World.

The dragon tree of the Canary Islands is notable for the existence of individuals believed to be the oldest living vegetable organism in the world. The age of one tree, in particular, the once famous dragon tree of Teneriffe, has usually been estimated to be from four thousand to six thousand years, having thus an antiquity comparable with that of the Pyramids. This wonder of the plant world was 70 ft. or more in height, and survived intact until the year 1819, when during a terrific storm one of the large branches was broken off. A similar storm in 1867 stripped the trunk of its remaining branches and left it standing alone. This tree derives its common name from a reddish exudation, known as dragon's blood, found in the sepulchral caves of the Guanches, and supposed to have been used by them in embalming their dead. It is said to have been at one time an important article of export from the Canaries, and has never fallen tirely into disuse.—Journal, New York Botanic Garden.

#### Superheated Steam.

Mr. H. H. Vaughn, assistant to the vice-president of the Canadian Pacific Railway, presented an able paper on the subject of superheated steam before the members of the New York Railroad Club, at a recent meeting. A number of records of tests of the Schmidt, Schenectady and the Canadian Pacific types of superheaters were read by Mr. Vaughn, and although the latter type evidently made the best showing in point of fuel economy, the general deductions he drew were marked by a spirit of fairness that could not be questioned. Mr. Vaughn's pointed presentation of facts and figures was altogether a strong argument in favor of the use of superheated steam. We ob-

The ALDON COMPANY  
1103 Monadnock Block  
CHICAGO, ILL.

## ALDON Car and Engine Replacer



Save Time, Labor and Damage to Equipment

No Loose Parts to Get Out of Order  
Gradual, Easy Lead to Rails

A Modern Appliance for Modern Roads

CIRCULAR ON APPLICATION

## Locomotive Engine Running and Management

By Angus Sinclair \$2.00 Best book in print for any railroad man

ANGUS SINCLAIR COMPANY

136 Liberty Street, New York

A Practically Perfect Portable Pneumatic

# PUNCH

Stop moving your heavy work to the machine. One Man brings this tool to the work and punches it besides.

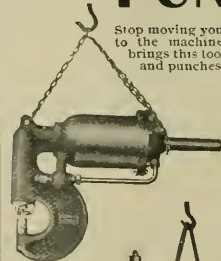

Punch Size 3

Built in 5 Standard Sizes. Special machines built to order. Write for Catalogue C.

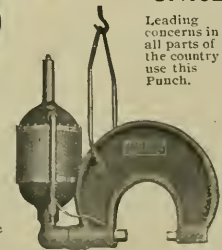

SAVES TIME LABOR SPACE

Leading concerns in all parts of the country use this Punch.

F. F. SLOCOMB & CO., Builders  
WILMINGTON, DEL.

This illustration shows the form of construction of the **DART PATENT UNION**

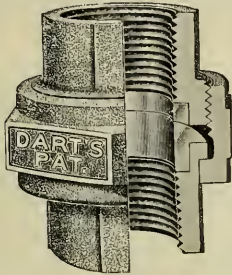

Every feature of construction represents the best points to insure stability and durability. The malleable iron pipe ends and nuts, in combination with bronze metal seats, are as near perfection as is possible to approach, and the sales to date indicate the public approval. There are none so good. For sale by all the principal jobbers in United States, Canada and Europe. **E. M. Dart Mfg. Co., Providence, R. I.** FAIRBANKS CO., SALES AGENTS.

# SKAT

Unexcelled

FOR

Taking Smut and Grease  
Off Railroad Men

Best Hand Soap Known

SKAT MFG. COMPANY  
791 Park Street, Hartford, Conn.

## Flexible Spout

Vertically in straight line. Also laterally. The latest improvement to

## Poage Water Columns

American Valve and Meter Company

CINCINNATI, OHIO

—SEND FOR CATALOGUE—

### Compound Locomotives

By FRED H. COLVIN, M.E. Tells everything an engineer needs to know about all kinds of American compound locomotives. \$1.00.

ANGUS SINCLAIR COMPANY  
136 Liberty Street New York

served, however, that the speaker avoided any reference to the cost of keeping in repair the mechanical contrivances used in the superheating of steam, and until this important item and also the cost of perfect lubrication, not to speak of the increased first cost in construction, are all added and compared with the actual saving of fuel on locomotives of corresponding weight engaged in the same traffic, the presentation of the results obtained is not altogether complete.

Mr. Ed. James, the popular superintendent of the new Lehigh Valley shops at Sayre, Pa., will present a paper

machines are heavy and massive, with plenty of well distributed metal in them. The hammers are double acting, and can be worked with air pressure as well as steam. They operate under perfect control with easy regulation and variation in the force of the blow, and are capable of continuously sustained automatic action. The valve gear is simple, and consists of few parts, while it gives accurate and sensitive control of the blow. The metal in the hammer casting is distributed so as to secure uniformity of thickness and shape. The column box only is cored. The bed plate is made in one piece, solid with

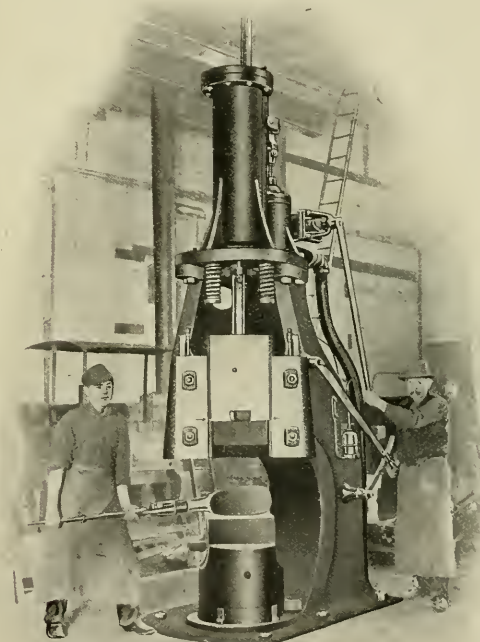

STEAM HAMMER AT WORK.

next month on the best methods of keeping a terminal repair shop going.

### Striking Features in a Hammer.

The steam hammer, which we are enabled to here illustrate, is one of the latest products of the David Bell Engineering Works, of Buffalo. These hammers are made in seven sizes, the cylinders range from 5½ up to 13 ins. in diameter, and the stroke varies from 18 to 36 ins. The weight of the falling parts of the smallest hammer is 350 lbs., while those of the largest weigh 2,000 lbs.

The general design shows that the

frame, with heavy ribs below the floor line, and there is heavy reinforcement around the die block opening. The guides are also reinforced, and the column is made exceedingly stiff by running a heavy web down both sides of the die block and by making the main frame at the base of the slides much heavier than is usually done.

The hammer head is set at the angle best suited for facility in drawing and finishing work either way of the guides. The head itself is made of hammered steel and is finished from the solid with milled V-shaped grooves, which work in adjustable slides. The slides are

# The Automobile Magazine

is the oldest, finest illustrated and most interesting publication devoted to automobiling. Its climbing properties are about equal to those of the car here shown hitting the hill.



Its motto is "help" for those who need knowledge about automobiles. It runs a free Information Bureau which is of great value to automobilists.

Send in two dollars, which will entitle you to receive the magazine for one year.

## Automobile Magazine

Electrical Exchange Building  
LIBERTY STREET, NEW YORK

heavy, bolted through to the main frame with spring washers on the bolts. The piston rod is fitted into a taper hole in the head, the jamb secured in this way constitutes the real hold. There is, however, a safety pin, which gives warning in case the rod ever shows signs of working loose.

The die block is in two pieces, with the top cap above the bed plate. This can be removed if more space is required for special work. In that case the lower die can be put into a dovetail slot in the lower die block. This lower die block is very heavy, and is made so, to absorb the force of the blow. It extends below the bed plate, and has a large square base. The dies are made of special open hearth steel and one set is supplied with each hammer. Every hammer is subjected to a working test before it leaves the makers' hands, and a plan of the foundation and directions for setting go out with each hammer. This engineering firm are making a specialty of steam hammers, and are running their entire plant exclusively on such work. They will be happy to furnish those interested with information on the subject, as they believe that their product contains some new and very striking features.

Corn specials, as they are called, are to be run by the Lake Shore and the Michigan Central for the enlightenment of the farming communities situated along their respective lines. Exhibits of produce will be made and meetings held, at which competent authorities will give instruction on agricultural matters, and they will speak of the importance of greater care in the selection of seed corn and of improved methods of growing all kinds of grain.

A well designed and efficient oil furnace is not merely a collection of bricks and fireclay in a stand of certain size and shape, it is something more, and a good idea of what it really is may be obtained by the perusal of a pamphlet issued by the Railway Materials Company, of Chicago. They say that oil is an ideal fuel, as it contains no ashes and every portion can be burned so as to produce heat. The Ferguson furnace is a low pressure oil burning device which has a suitable combustion chamber and means for independently controlling the oil and air supplied. In these furnaces the oil leaves the burner in a thin film, as it may be fed by gravity or equivalent air pressure, and being brought into contact with the first supply of air it is volatilized. As it passes up the primary combustion chamber it is ignited, but on reaching the secondary combustion chamber, it is fully and completely burned with the maximum production of heat. The pamphlet tells how this

## WASHBURN COMPANY

Minneapolis, Minn.

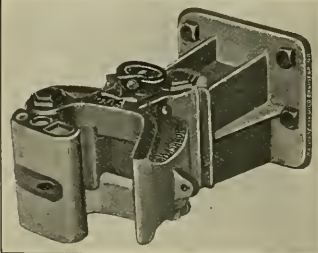

Automatic couplers for freight, engine and passenger service.

Draft riggings and buffer attachments for freight and passenger cars.

Special couplers for narrow gauge and plantation service a specialty.

Steel castings of all descriptions.



## The Twentieth Century Master Mechanic

Won't use Solid Mandrels. Cost too much, take up too much room and don't give satisfaction.

### Nicholson Expanding Mandrels

Take everything from 1 to 7 inch holes. Take up little room — always ready and you can buy four sets for the cost of one of the solid kind.

Are You Using Them?

Catalogue tells you more about them.

**W. H. Nicholson & Co.**  
Wilkesbarre, Pa.

# Locomotives, Freight and Passenger Cars

All equipment rebuilt in our Chicago shops, and at Scranton, Pa., in the new "Lackawanna" Shops

## All Kinds of Cars and Engines Ready for Immediate Delivery

RELEASED BY TRUNK LINES

1000—60,000 LBS. CAPACITY REBUILT FLATS AND GONDOLAS

2000—50,000 LBS. CAPACITY FLATS, BOX AND GONDOLAS

COACHES, COMBINATION AND BAGGAGE CARS

FOREIGN SHIPMENTS HAVE PROPER CARE OF  
EXPERIENCED STAFF

Cable Address

"FITZLUTH"

55 AND 70 TONS CONSOLIDATIONS

45 AND 50 " 10-WHEELERS

40 TO 55 " MOGULS

45 TO 50 " PASSENGERS

SWITCHERS, FORNEYS AND SHAY ENGINES

**FITZ-HUGH, LUTHER CO. Monadhock Block. CHICAGO**  
 14 BROADWAY NEW YORK  
 CHEMICAL BLDG ST. LOUIS  
 80 ST. FRANCIS XAVIER ST. MONTREAL, CAN.  
 RIALTO BLDG. SAN FRANCISCO

is accomplished and the illustrations show how it is done. The company will be happy to send a copy of their very instructive and artistically printed publication to anyone who is sufficiently interested in the subject of scientific oil burning to write to them and ask for one.

### General Foremen's Association.

The International Railway General Foremen's Association Convention, which will be held at St. Louis, Mo., on May 8, promises to be an important gathering of men actively engaged in the superintendence of locomotive construction and repairs. The subjects to be discussed are all of vital importance and the report of the proceedings will be awaited with much interest. There are ten special topics to be discussed, and committees have been at work during the winter months preparing data for the documents which will be submitted. The general exchange of views along the lines pertaining to railway locomotive shop practices cannot fail to be interesting and all will profit by the gathered experience of others.

### How to Work.

Here is a very good piece of advice for those who feel that they can occasionally take a little. It is from Dr. William Osler, who some time ago was credited with saying that after a certain age a man ought to be chloroformed. What the doctor was alluding to was the novel written by Anthony Trollope called "The Fixed Period," in which some such idea was humorously treated, and the Doctor did not originate the idea and, we believe, did not endorse it, though he was rather insistently credited with having done both. Speaking of work, which we all have to do in this world, he said:

"How can you take the greatest possible advantage with the least possible strain? By cultivating system. I say cultivating advisedly, since some of you

will find the acquisition of systematic habits very hard. There are minds congenitally systematic; others have a lifelong fight against an inherited tendency to diffusiveness and carelessness in work. A few brilliant fellows have to dispense with it altogether, but they are a burden to their brethren and a sore trial to their intimates."

### Concrete Is Hard.

A very interesting demonstration of the degree of hardness which well made concrete may have was afforded a short time ago in Philadelphia. One of the new subway stations in the Quaker City had been laid with concrete at the rail level, and it was found necessary to lower this floor a few inches. The work was done by the use of a cold set held in position by one man while two others let heavy, long arm drop blows fall on it with 25 lb. sledges, as a blacksmith and his helpers might flatten the surface of a steel bar.

The result of this method of cutting the concrete was that the cold set was driven slowly into the strongly resisting material and only a few meager chips of concrete were broken out at a time. The work was necessarily very slow, and, for that reason, expensive, but it was persevered in, notwithstanding that the concrete was found to be as hard as some kinds of stone. There may be more expeditious methods of removing concrete, but whatever form of procedure is adopted in a case like this, the exceeding hardness of the concrete and its ability to resist forcible dislodgment will always be the predominating factor in the problem.

### Change of Location.

The Erecting Department of the Westinghouse Electric and Manufacturing Company, for Manhattan Borough, which until recently was located in the Trinity Building, has been moved to the Fuller Building, corner of 23d

street and Broadway, New York, commonly called the "Flatiron." This change was made necessary because the department was in want of more space than it was possible to obtain at 111 Broadway, and also because the uptown location is more suitable and convenient for the construction work, most of the power plants being located within easy reaching distance.

### Transcontinental Contracts.

The Grand Trunk Pacific Railway Company have let contracts for 457 miles of main line, which, with 275 miles from Portage la Prairie west and the Lake Superior branch, 210 miles long, making 942 miles under contract. This will carry the main line as far west as Edmonton, Alta., beyond which there will not likely be any addition this year. The government will build 395 miles of line between Moncton, N. B., and Winnipeg, Man. Among other works contracted for is the James Bay Railway, 208 miles, and the Halifax & Southwestern, 86 miles, and the Great Northern of Canada, 110 miles. To these may be added nearly 500 miles of branch lines of the Canadian Pacific Railway now under construction.

### Thirteenth Annual Convention.

The coming Air Brake Convention will be held in Montreal, Canada, June 5, 6 and 7 next. The date of holding this convention is later than usual, but it was decided upon because of weather conditions in Canada.

The Canadian members of the Air Brake Association have long desired to secure a convention, and now express their intention of making the next convention the most successful and enjoyable in the history of the organization. The visiting members may rest assured that their intention will be realized in the most satisfactory manner.

The Windsor Hotel has been select-

# World's Fair

## St. Louis

### FIRST PRIZE FOR

# TOOL STEEL

### AWARDED TO

## McInnes Steel Co.

### CORRY, PA.

in competition with the best makes in England and Germany. Also manufacturers of all kinds of Tool Steel, Die Blocks, and Steel Forgings.

Write for Prices and Information

STANDARD MECHANICAL BOOKS  
FOR ROAD AND SHOP MEN  
BY CHAS. McSHANE

The  
Locomotive Up to Date

Price, \$2.50

New York and  
Westinghouse Air Brakes

Price, \$1.50

One Thousand Pointers for  
Machinists and Engineers

Price, \$1.50

All books bound in fine cloth

AGENTS WANTED everywhere; write for terms and descriptive circulars. Will be sent prepaid to any address upon receipt of price.

GRIFFIN & WINTERS  
171 La Salle Street, CHICAGO

ed as the headquarters for the convention, and the committee on arrangements requests that all members secure accommodations at that hotel, since it is certain that they will be courteously entertained there, and because there is the added advantage of having all members at the same place; however, it is optional as to where accommodations are secured.

While some difficulty may be experienced in procuring free transportation on roads in the United States, none is anticipated in Canadian territory; therefore members should try to reach a Canadian road as soon as possible en route. The Canadian Pacific runs its own sleeping cars, and Pullman arrangements will not cover sleeping cars on this line. Other Canadian roads use Pullman cars, where arrangements secured with the Pullman people will hold good.

Circulars, giving all particulars regarding sleeping car arrangements, have been mailed to the members, and the blank form of request for the half rate privilege should be promptly filled out and mailed to Mr. F. M. Nellis, Secretary. Present indications are that the attendance will be the largest of any convention yet held. The subjects to be discussed are of more than ordinary interest, so that all who can attend will find it profitable to do so.

Fans for office and shop use driven by electric motors will soon be in season, and the way to become "posted" on what kinds are made and what they will do is to secure a copy of the very artistic catalogue issued by the Westinghouse Electric and Manufacturing Company, of Pittsburgh, Pa. If you want to be particular about it when you write for one, the catalogue we speak of is called "Special Publication No. 7043." There are A. C. and D. C. fans made by this company and these initials stand for alternating current and for direct current, and the price, size, voltage, style, etc., are given, and besides there is a lot of general and particular information on the subject to be had by a perusal of the little book. The company have also issued a circular on a related subject. It is No. 1128, and deals with small power motors. These are suitable for a variety of uses, such as turning the stirring paddles of an ice cream freezer or running a coffee mill. There is a picture of a rotary neostyle being driven by one of these motors. A neostyle is what is used in many offices for multiplying circulars. It is very evident from the examples given that these small power motors can be employed to advantage both in the office and the shop to do a lot of work which is usually done by hand. If you want a copy of this circular or the one

on fan motors write to the makers and ask for either or both. You might want a small motor this summer, or you might simply want to be fanned.

### Locomotives for the Philippines.

Consl Hamm, of Hull, sends the following item of news which appeared in the Yorkshire Post of recent date: "A correspondent is authoritatively informed that an important contract for supplying eight powerful six wheel coupled bogie freight locomotives for the Manila Railway Company has, in the face of severe continental competition, been awarded to Messrs. Kerr, Stuart & Co. (Limited), of the Californian Works, Stoke-on-Trent. Early delivery was an important feature in the placing of the contract with British engineers, and the locomotives are to be shortly shipped to the port of Manila."

The Wabash lines east of Toledo and the Baltimore & Ohio are said to be in urgent need of telegraph operators, and the last named road wants operators for interlocking signals. Difficulty is reported in finding competent men.

Use beeswax instead of putty in nail holes in yellow pine. It matches the color and no one can tell where the nail holes are without making a very close inspection.

The fool who has not sense to discriminate between what is good and what is bad is well nigh as dangerous as the man who does discriminate and yet chooses the bad.—Roosevelt.

### CONTENTS.

	PAGE
*Air Brake, Dukessmith.....	227
*Air Brake Department.....	217
Hook Notices.....	219
*Bridge Over Schuylkill River.....	193
Boiler Design, Essentials in.....	223
*Band R p and Resaw.....	233
Cars:	
New Form of Sleeping.....	199
Flat of Unique Design.....	223
Cooling Station, New.....	223
Clearing for a Terminal.....	235
Editorials:	
Engines, Some Slippery.....	220
Locomotive Trials.....	210
Notices in Railway Cars.....	210
Passenger Cars, Sanitation.....	209
Per Diem Charge Changed.....	210
San Francisco.....	210
Trade Unions.....	209
*General Correspondence.....	101
Locomotives:	
Culm Burner for D. L. & W.....	223
Electric for N. Y., N. H. & H.....	211
French 4-6-0 Compound.....	205
Simple 4-6-2 for the C. & S. L.....	234
*Milling Machine, Portable.....	224
Machine Blacksmith.....	229
Man Who Sells Things.....	222
Our Correspondence School.....	213
Officers of Technical Publicity Assn.....	233
Personals.....	225
Patent Office Department.....	225
Questions Answered.....	225
*Steam Hammer, New.....	227
Shop Kinks:	
Portable Bolt Lathe.....	210
Simple Modest Door Closer.....	210
Sure Thing.....	232
*Valve and Valve Motion, Development of, by Angus Sinclair.....	196

# Railway and Locomotive Engineering

Copyright by Angus Sinclair Co.—1906

A Practical Journal of Railway Motive Power and Rolling Stock

Vol. XIX.

136 Liberty Street, New York, June, 1906

No. 6



RAILWAY AND LOCOMOTIVE ENGINEERING

TRACK WATCHMAN PASSING THROUGH TUNNEL ON THE ESQUIMALT & NANAIMO RAILWAY, BRITISH COLUMBIA.

### Driving a Tunnel.

Tunnel building in some form or other is an exceedingly ancient art, and, perhaps, had its earliest development in Egypt. In those far-off days the only tools which could be applied to the work were rude hand-made implements, and the most powerful agency which the ancients knew how to employ was the system known as "fire-setting." This consisted of lighting a fire of wood on the rocks which it was desired to disintegrate, and when they had become hot, they were suddenly cooled by the application of water, and sometimes of vinegar, which caused the heated stone to crack, after which a few fragments were removed by hand and fire setting was again resorted to.

In making excavations, or, as we would say, in driving tunnels, the fire setting system was necessarily a very slow process and it had the additional disadvantage that the fire vitiated the atmosphere and when it was extinguished in the process of cooling the rock, large quantities of smoke were given off, which, with the then imperfect methods of ventilation, was difficult to get rid of even after the rock had been split.

It was by this curious kind of tunnel driving that Caliph Al Mamoun forced an entrance into the great pyramid of Egypt. It had been sealed from the time of its building, about 2700 B. C., until he was able to effect an entrance in the year 820 A. D. The door of the pyramid, placed about 24 ft. to the left of the center line, had been concealed very carefully by the builders and each of the pyramid's enormous sloping sides had been covered with casing stones of smooth, polished, dense white limestone, which shone in the sunlight like the "terrible crystal" spoken of in Ezekiel. No doorway being visible, the Caliph believing the pyramid to contain untold treasure, forced an entrance with the aid of hammers, fire and vinegar. No treasure was ever found and it has been left for modern science to reveal the

poses. An example of a Roman tunnel built as part of a highway, was that constructed by the Emperor Vespasian, which carried the Flaminian way through the range of the Apennines. The tun-

men were called "leggers" on account of the way they employed their lower limbs to furnish the necessary motive power. These tunnels were mostly through hard ground and were driven by

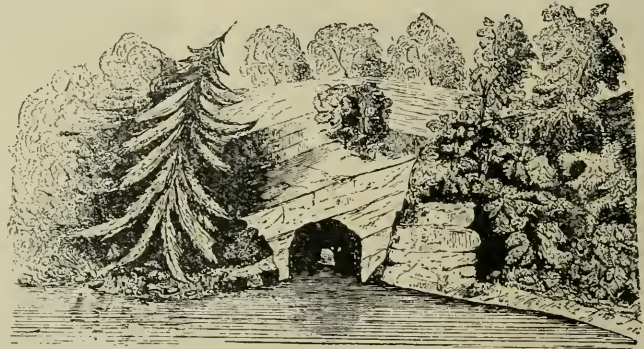

FIRST TUNNEL IN AMERICA.  
(Reproduced from "Drinker's Tunneling.")

nel of Pasilipo, on the road from Naples to Pozzuoli, was built about 36 B. C., and is in use at the present time.

The early tunnels in England were built in connection with canals, as, indeed, they were in this country. The first English canal tunnel was finished in 1777, and was on what was called the Grand Trunk Canal. It was 9 ft. wide, 12 ft. high, and permitted a 7 ft. boat moderately loaded, to pass through.

the fire setting system, though later on, pick and gad were used when soft ground had to be attacked.

The year 1821 saw the completion of the first tunnel ever constructed in the United States. It was situated not far from Philadelphia, on the canal leading from Norristown to tidewater at the falls of the Schuylkill, and was the outlet for the coal regions in the vicinity of that river. It was above Auburn, Pa., at a place called Orwigsbury landing. The tunnel was 450 ft. long, 20 ft. wide by 18 ft. high, and was driven through red shale. The greatest thickness of rock above the tunnel was 40 ft., and the passage was some years afterwards made into an open cut. The second tunnel in point of time in this country and the first large mining tunnel was the Hacklebernie Tunnel near Mauch Chunk, Pa., began in 1824 by the Lehigh Coal and Navigation Company. In the construction of this tunnel, which was 16 ft. wide by 8 ft. high, about 3,745 cubic yards of rock were taken out at a cost of \$7.16 per cubic yard. The first railroad tunnel was on the Allegheny Portage Railway in Pennsylvania. It was begun in 1831 and finished in 1833. This tunnel, driven through slate, was 901 ft. long, 25 ft. wide, arranged for a double track road, and was 21 ft. high. It was arched with stone, 18 ins. thick, for a distance of 150 ft. in from each end. The contract price for excavation was \$1.47 per cubic yard. The railroad using this tunnel was built to connect the central and western divisions of the Pennsylvania Canal.



MINK TUNNEL, LAKE SUPERIOR DIVISION, C. P. R.

probable intention of the architect of the most ancient and the most enduring building on earth.

The Romans were also tunnel builders, many of their works being for the conveyance of water or for drainage pur-

The way the boat was made to move was curious enough. Men lay on their backs on top of the load of freight which the boat carried and they pushed against the sides and roof of the tunnel with their feet and so forced the boat along. These

There are many modern methods of tunnel driving, one of them, which has been called the American center cut system of heading blasting, is more or less typical of the others, and was first tried on the Hoosac Tunnel, and subsequently



introduced at Musconetcong, and in other similar undertakings. The Hoosac tunnel is on the Boston & Albany railroad. It is situated in Berkshire county, Mass., and is about  $4\frac{3}{4}$  miles long, and

angle with the center line of the tunnel, and when the rock has been broken out by the electrically fired blast and removed, a final set of holes, parallel to the tunnel center line, are drilled and

or cars used in removing the broken stone. The drills are operated by compressed air, piped along the heading and conveyed to the machines through rubber hose. Headings are run from both ends of the tunnel at the same time, and eventually meet at or near the center.

The work of taking out the bottom of the tunnel is carried on by drilling sloping holes downward through the floor of the heading and also by approaching them with holes drilled close along the floor of the main tunnel. As the work progresses temporary tracks are laid along the tunnel floor which are used for the bottoming drill carriages and for removal of broken rock as each blast sets it free. In the process of taking out the bottom of the tunnel and before each blast, the drill carriages in the heading are run in toward the center of the tunnel while those on the main floor are backed toward the portals. When the tunnel has been finally driven, any jagged pieces of projecting rock are trimmed off so that at least the required clearance for railway traffic will be had all the way through.

The driving of sub-aqueous tunnels is, in a way, a more daring feat of engineering than the building of rock-hewn galleries in the mountains, because the ground in which such work is done is usually soft and the danger of the tunnel being flooded is a constant menace to the builders. In tunnel work under rivers the advance is generally made by pushing a circular



VIEW TAKEN FROM INTERIOR OF ONE TUNNEL SHOWING OPENING OF THREE OTHERS. FRASER CANYON, B. C.

is large enough for two tracks. The rock penetrated in driving this tunnel was principally micaceous schist.

A heading is practically a small tunnel usually driven in hard material at the top of what will later on be the finished tunnel. A fairly accurate metal picture of what a top heading is like, may be had by supposing the back sheet of a wagon-top locomotive boiler to represent the cross section of the finished tunnel. In such an arrangement that portion lying above the crown sheet would correspond to the heading and the rock would be taken out by the center cut system of blasting.

This system consists of drilling, say, six holes in two vertical rows, of three each, about 9 or 10 ft. apart and at such an angle that each pair shall meet or cross at the bottom. When these holes are fired, a vertical wedge-shaped quantity of rock is taken out. The squaring up process is carried on by drilling two vertical lines of holes a few feet from the edges of the entering wedge made by the first excavation. These are drilled at a lesser angle, with the center line of the tunnel, and when they are fired the sides of the wedge are taken out, leaving the floor area of the heading something like the shape of blunt wedge, or like the back of an ordinary journal bearing for cars. A third series of holes is then drilled a few feet from the newly formed edges of the blunt wedge-shaped excavation. These holes make a still smaller

fired, and thus a total advance of about 8 or 10 ft. of heading has been made.

The drill carriages, which are strong, rough frames, are mounted on wheels



JACK FISH TUNNEL, NORTH SHORE OF LAKE SUPERIOR, ON THE CANADIAN PACIFIC RAILWAY.

and are moved on temporary tracks. The carriages are run back to a safe distance when blasting is going on, and the tracks are afterwards occupied by the trucks

shield forward through the yielding material and excavating up to the cutting edge of the shield before another advance is attempted.

The general form of shield for this kind of work is circular and it is made of boiler plate, and is the full size of the tunnel. The shield is really a huge ring, and when pushed forward cuts into the ground in front of it very much in the same way that a biscuit cutter in the hands of a good housewife cuts out circular cakes from a flat rolled-out lay-

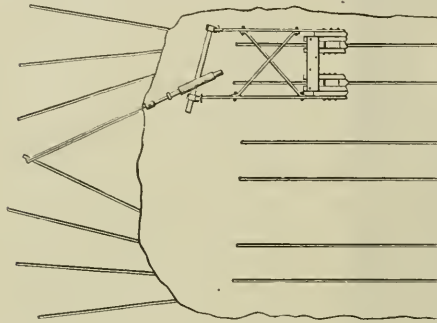

CENTER CUT METHOD OF HEADING DRILLING.  
(From "Drinker's Tunneling.")

er of dough. The chef-de-cuisine, however, uses hand pressure for the work, while the tunnel shield is made to cut out its cake by the combined pressure of perhaps a couple of dozen powerful hydraulic jacks. The base upon which all the jacks press in order to drive the cutting edge forward for each advance is the iron lining of the tunnel which is put in place in a series of sectional rings behind the shield as the work goes forward.

The shield used in driving the St. Clair tunnel was 21 ft. 6 ins. in diameter and about 15 ft. long, with two vertical partitions near the back, and a couple of horizontal floors dividing the circle into three zones. Upon these floors men worked excavating all the material within the ring. The partitions at the back were separated by a space of about 4 ft. and sliding doors gave access from one "room" to the other. The interior of the shield was, of course, filled with air but it was raised to a sufficient pressure above that of the atmosphere to prevent water and mud from oozing in too fast. When the shield was about to be advanced the doors in the front partition were closed and the air pressure was raised in what we have called the rooms in the head of the shield. When the advance had been made, the workmen entered the rooms between the two partitions and closed the sliding doors behind them. The pressure was then raised and they opened the doors and entered the head of the shield and began to cut down the wall of earthy material in front of them, passing back the excavated material into the space between the partitions. When a sufficient amount had thus been passed

back, the doors in the front partition were closed and those in the back partition were opened and the material removed into the interior of the tunnel and taken away, and when all the material which the cutting ring of the shield had enclosed had been removed another advance would be made and the operation repeated. In this way the shield would be advanced each time a distance equal to the stroke of the hydraulic jacks, and the two partitions with their sliding doors, never both opened at the same time, would always preserve a very efficient air lock at the point where soft or wet material was being cut into and removed.

The tube of the St. Clair tunnel is 6,025 ft. long, with open approaches amounting to 5,603 ft. additional, thus making it one of the longest submarine tunnels in the world. The total weight of iron in the lining tube is about 56,000,000 lbs., and it took about three years to build the tunnel. It is on the Grand Trunk Railway under the St. Clair river, and joins the town of Sarnia on the Canadian side with Port Huron on the American side of the international boundary. It is a wonderful piece of engineering and a traveler from the "States" passing through the great bore enters the "Northern Zone" through the

have become practically meaningless, due to the natural course of improvement. The nominal horse power of an engine was originally based upon a definite piston speed in feet per minute, and those who are curious may find various rules on the subject in old publications.

As engines were improved and used less steam to produce a "horse power," the horse power of any given boiler was increased in rating or performance with each reduction in the steam required, and in addition the boiler itself was improved, and new designs were brought out which gave greater results in quantity of water evaporated per pound of fuel consumed. James Watt fixed upon 1 cu. ft., or  $62\frac{1}{2}$  lbs. of water evaporated per hour, as the standard horse power of a boiler. Other engineers made rules based upon such standards as 1 sq. yd. (9 sq. ft.) of heating surface, or 1 cu. yd. of capacity. Such boilers were supposed to require 1 sq. ft. of fire grate surface to develop the unit h.p. These rules, which were useful enough and sufficiently accurate in their day, have all given way to a common standard and this is the amount of water evaporated "from and at"  $212^{\circ}$  F., which is  $34\frac{1}{2}$  lbs. In common practice this is equivalent to about 30 lbs. of feed water at  $100^{\circ}$  F. evaporated at 70 lbs. gauge pressure. The term "from and at  $212^{\circ}$  F." means, from water at  $212^{\circ}$  F. into steam at  $212^{\circ}$  F., that is, at atmospheric pressure, and it is calculated from the actual amount of feed water at the temperature of the supply, and the temperature of the steam at the boiling



TAKING OUT BOTTOM BY HOLES DRILLED FROM HEADING AND ALONG FLOOR.  
(Reproduced from "Drinker's Tunneling.")

under water gateway to the Dominion, for it is, indeed, what the guidebooks call it, the "link that binds two nations."

### Horse Power of Boilers.

BY ROGER ATKINSON.

The use of the term "horse power" for it is, indeed, what the guidebooks call it, the "link that binds two nations." for many years, just as the term "nominal horse power" has also gone out of use, though it was formerly used to express the size of an engine. Both expressions

point corresponding to the pressure carried in the boiler, so that all boiler performances may be compared upon an accurate basis. This allows for, first, the number of units of heat required to raise the temperature of each pound of feed water up to the boiling point, and, second, for the units of heat required to convert each pound of the water into steam at the same temperature.

For ordinary rough calculations the amount of water actually evaporated by the boiler during test is reduced to the equivalent evaporation "from and at  $212^{\circ}$  F." in the following way: For each

pound of water raised from the feed temperature at 100° F. to the boiling point for steam at 70 lbs. pressure which is 316° F., we have to allow one unit of heat for each degree  $316 - 100 = 216$

water varies greatly according to the type of boiler and the proportion of grate area, but generally speaking, the Lancashire type, where the ratio of heating surface to grate area may be from

where 1 h.p. has been shown for 1 sq. ft. These records, however, must be considered largely fictitious, as the horse power shown by the indicator diagram taken when running down hill can be made very high and be very misleading.

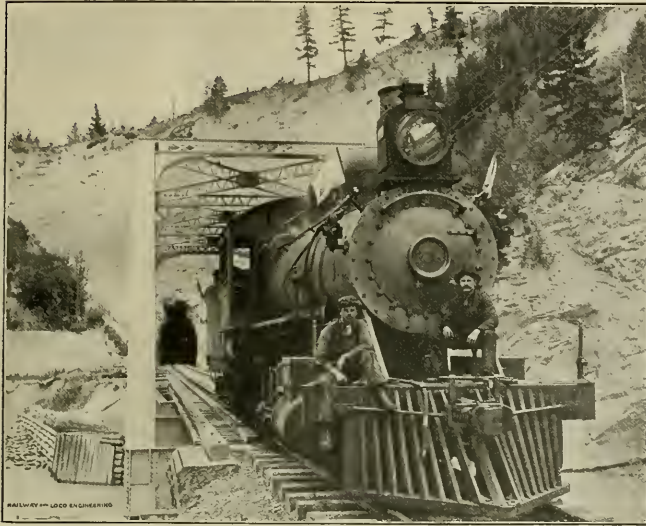

PUSHER ENGINE AND TUNNEL, IN THE ROCKY MOUNTAINS. CAN. PAC. RY.

**Nicknames of Railroads.**

An old engineer on the Wabash, when speaking of the nicknames for railroads, said: "The old T., P. & W. was known in the early days as the Tipup, Tired, Poor & Weary, and Tobacco, Pipe & Whisky Road.

"What is now called the Panhandle was known as the 'Jerk Water,' from the fact that water was secured by stopping the engines and drawing water from the creeks along the line.

"The C., W. & M., now the Big Four, was at one time called the 'Tri-Weekly,' and the old-timers used to say of it, 'Go up one week and try to get back the next.'

"The Wabash was then known as the Toledo, Kansas City & Western, or, better still, as the 'Torn, Worn & Worthless.' The engines were all wood burners, and the firemen used to say that they had to put in crooked logs to enable the engines to get around the curves.

"The Vandalia, once the Logansport, Crawfordsville & Southwestern, was known as the 'Pumpkin Vine' and the 'Dolly Varden.' I once went over the road, and weeds were so high that I

units. Then we have to add 893 units of heat required to convert each pound of water at 316° F. into steam, which is the latent heat of steam at 70 lbs. gauge pressure, thus making the total  $216 + 893 = 1,109$  units of heat absorbed per lb. of water. Now it takes about 966 units of heat to convert one pound of water, from water at 212° F. into steam at 212° F. at atmospheric pressure. So that it takes  $1,109 \div 966 = 1.148$  times as much heat to raise water from 100° F to steam at 70 lbs., as it does to convert water at 212° F. into steam at 212° F., and if we apply this rule to the standard mentioned above, that is, 30 lbs. of water per horse power, we get  $1.148 \times 30 = 34.44$ , or about  $34\frac{1}{2}$  lbs. per horse power from and at 212°.

If we take as an average the evaporation due to the burning of 1 lb. of coal as  $7\frac{1}{2}$  lbs. of water, we would have 4 lbs. of fuel consumed for each horse power developed by 30 lbs. of steam. This may be taken as a common standard for ordinary stationary engines in fair order. If this steam were used in a modern high pressure compound condensing engine requiring only 15 lbs. of water per horse power, indicated, we should get a horse power from 2 lbs. of coal, or the boiler would be developing twice its former rated horse power.

The number of square feet of heating surface required to evaporate 30 lbs. of

15 to 1 or 25 to 1 requires about 7 sq. ft. Multitubular boilers with ratio of 30 to 1 or 40 to 1 require about  $4\frac{1}{2}$  sq. ft. of



SOUTH PORTAL OF THE ST. CLAIR RIVER TUNNEL.

heating surface per horse power of 30 lbs. water evaporated. Locomotives generally require about 3 sq. ft., but in rare cases, records have been given

could not see the rails."

Humility and a sense of humor are rare aids in work.—Paget.

### Development of Valve and Valve Motion.\*

BY ANGUS SINCLAIR.

#### PART FOUR.

##### COMBINED LINK AND CAM MOTION.

In 1866 the valve gearing shown in Fig. 37, which was designed and patented by Messrs. Uhry & Luttgens, was applied to an engine built by Rogers for the Central Railroad of New Jersey. In this there was an ordinary shifting link worked by two eccentrics and connected with a pin attached to the lower arm of a rocking shaft in the usual way. What may be called a supplementary rocking shaft, *R, R'*, was pivoted to the top pin of the main rocking shaft. The lower arm *R'* of the supplementary rocking shaft was bent into a half circle, as shown, in order to clear the main rocking shaft *M*. The supplementary rocker was worked by a cam *O'*, which was connected to a pin *P*. The effect of the action of the cam was to accelerate the movement of the valve at the time that it opens the ports for admission and exhaust. Its adjustment gives about 50 per cent. greater opening of steam port. The point of exhaust is retarded from 5 to 6 ins. beyond the link motion, while the point of compression remains the same. The size of opening of the exhaust is somewhat larger than with the link motion, and it is opened in less time, thereby producing a strong and clear exhaust.

This motion gave a quick port opening, delayed but sudden release, and provided about the proper amount of compression, but it was not applied to a second engine.

##### CORLISS VALVES ON LOCOMOTIVES.

The valve and gear shown in section in Fig 38 is an adaptation of the Corliss principle to suit the requirements of locomotive practice. It was designed by Mr. O. W. Young and consists of two valves for each cylinder, operating al-

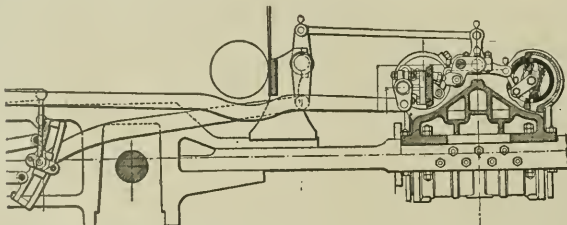

FIG. 38. SECTION OF YOUNG'S ADAPTATION OF THE CORLISS PRINCIPLE.

ternately as inlet and outlet and driven by the Corliss wrist motion, used in connection with the Stephenson link. An original device is provided for correcting

\*This is part of a historical article for my forthcoming book, "Development of the Locomotive Engine." If readers find mistakes of facts, they will oblige me very much by pointing them out."  
ANGUS SINCLAIR.

the irregularities in lead and either a constant or a slightly increased steam lead for the shorter cut-offs can be obtained, and an excessive pre-admission of steam avoided. The exhaust lead by this device is caused to increase as the cut-off is shortened and permits an exhaust lap for long cut-offs, changing to exhaust clearance for a short cut-off.

The valves consist of cast iron strips outside the exhaust cavity and partitioning the live from exhaust steam. The strips are free to move towards or from their seats, and are independent of each other. Each strip follows its own individual path of travel and adjusts itself to any irregularities in the seat over which it moves. The valve body or carrier is journaled at each end and its weight is supported entirely clear

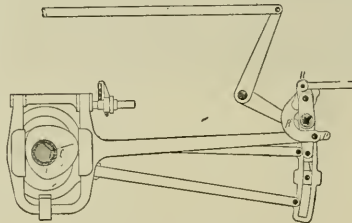

UHRY & LUTTGENS' CAM-LINK MOTION, 1866.

of the valve seat, the only weight on the seat being that of the strips.

##### ALLFREE-HUBBELL GEAR.

In this gear the valve seat is tilted about 15°, thereby providing for the use of one end of the valve, as well as

the valve faces, for admission and exhaust; and there is also an independent valve for controlling the exhaust, practically making it equivalent to a four-valve engine with only two ports to the cylinder. No auxiliary motion is used, the cylinders are bolted to the boiler in the usual way and the valve stem is connected to the existing valve motion of

the locomotive, be it Stephenson, Walschaert, Marshall, Joy or any other motion which gives a movement to the valve parallel to the line of the cylinder axis. The exhaust valves are 1¼ ins. less the distance over all, than the main steam valves. In the dash pot connection between the main steam valve and the exhaust valve, a movement of 1¼ ins. is provided for, so that when the main valves open for exhaust, the independent exhaust valves open at the

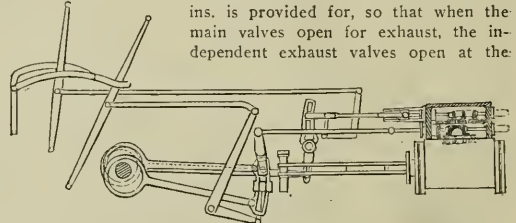

ROGERS' LINK MOTION AND INDEPENDENT CUT-OFF.

same instant and with exactly the same movement as the main steam valve, so that when the exhaust takes place there is an additional area of exhaust port opening equal to the area of the independent exhaust valves, and which are 5 ins. in diameter, and this arrangement secures a considerably increased port opening, thus giving a very free exhaust of the steam from the cylinders, thus reducing back pressure, and the final closure of the exhaust port is delayed until late in the stroke through the dash pot connection between the main steam valve and the exhaust valves. Increased expansion is secured by giving about ⅞ of an inch exhaust lap to the main steam valve.

##### Care and Maintenance of Locomotives.

An excellent paper on this subject was presented by Mr. E. T. James, superintendent of the new repair shops of the Lehigh Valley Railroad at Sayre, Pa., to the members of the New York Railroad Club at the last regular meeting. Mr. James had gathered his array of facts from a wide and varied experience and showed a thorough familiarity with the subject. He is a firm believer in the classification of work, and that each man or group of men should be assigned to a certain kind of work, for which they should be held responsible. In the matter of running repairs and roundhouse work, he particularly insisted on the necessity of maintaining a force sufficiently large to care promptly for the work and still keep down the cost of repairs as low as is consistent with good service.

His recommendations were in marked contrast to the methods in vogue in many roundhouses where the scarcity of hands is only equaled by the lack of tools, while the sanitary conditions seem to be something unthought of by the heads of departments who seem bent on making a false record for econ-

omy. Reproach for this sort of thing has come down through the centuries, and, perhaps, found its best expression in Hood's "Song of the Shirt," with its

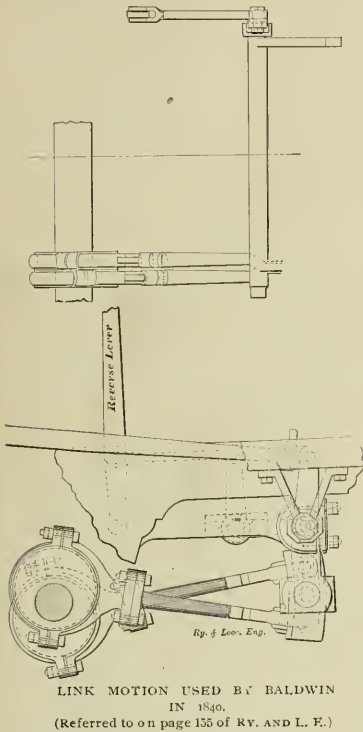

better work and more of it, than if they were allowed to work in wet and dirty pits, and floor littered with old scrap material and refuse. Good lighting facilities should be provided so that the men can see to do their work properly when working at night or at any time or place where artificial light is required."

Those of us who have worked many nights in dilapidated roundhouses where the building was so small and the locomotives so large that a portion of the tank was projecting out in the open air, can echo the opinions of Mr. James that anything approaching such conditions is out of date.

In the matter of general repairs also, Mr. James spoke with fine sense when he pointed out that locomotives that have undergone repairs should be carefully tested for several days. In some shops it is customary to send a newly repaired locomotive out on the road after a hurried trial of a few hundred yards, and in the event of any defect appearing the unfortunate gang foreman, under whose supervision the repairs were made, would be berated by some thoughtless, hot-headed general foreman whose stupidity would be almost equaled by his arrogance.

Mr. James' method, to use his own words, would be with a newly repaired "engine in preliminary or preparatory

tent engine crews for this work. The engineman must be a man of good judgment, careful and reliable, and be familiar with the service to which the engine will be assigned and the class of work it will perform when on its regular run, so that he will be able to make an intelligent report, based on his experience as to when the engine is ready to go into regular service. After receiving the engine he should go over all parts carefully, see that the boiler,

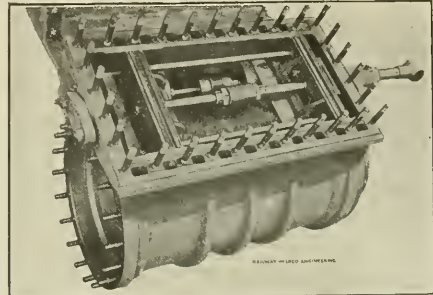

FIG. 33. ARRANGEMENT OF ALLFREE-HUBBELL VALVES.

fire box and necessary attachments are O. K., all keys, cotters and set screws are in proper position, motion work and running gear in good condition; also see that all oil and grease cups are filled and in working order, and as far as possible ascertain if the engine is in proper condition for trial service, as very much depends on the way this part of the work is done. The method of doing this work is largely instru-

sad cry of, "Oh, that bread should be so dear, and flesh and blood so cheap!"

It is a promising sign in the twentieth century when we see the heads of departments of great railways pause in the multitude of affairs that crowd upon them and point out, as Mr. James does, that when the volume of business is large and power is in constant demand it is necessary immediately to increase the regular service with additional men in order to prevent delays to trains and congestion in the yards. Not only so, but Mr. James explicitly states that in order "To get the best service from the men doing this work, it is very necessary for the foreman to see that the engine house or terminal is kept clean and neat as conditions will permit. The pits should be kept clean and free of water, dirt, rubbish and scrap material, as actual working conditions will permit; the floor should be kept clean and all scrap material removed from engines taken away as soon as possible, to permit the men employed in inspecting and making repairs to have ample room and good facilities to carry on their work under the best possible conditions. By doing this the men will do



D. & H. ENGINE WITH YOUNG'S ROCKING VALVES.

service to have a substantial trial, especially if repairs have been heavy, bearings new, and motion work having received general renewal of parts. Care must be exercised in selecting compe-

mental in deciding the successful performance of the engine when in regular service. If proper care and attention is exercised a large amount of trouble may be prevented when engine is in

service, on account of heating and other defects."

This is real work, and if it is quietly and conscientiously done it is a most important factor in the good result which is sure to follow. There is no reason for mere fault-finding on the part of the man who does this work, nor should he pretend to look for perfection.

In regard to the duties of engineers, Mr. James believes that they should be "held responsible for the condition of the engine on the completion of the trip, as far as the parts he has control over, and should make a report of all work required to be done, to the proper official, or in a book provided for the purpose. Any neglect on his part in caring for this important work should be carefully looked into, and if it is proved that he is habitually careless or negligent, he should be disciplined. It is very essential to the successful op-

ording to conditions and location of terminal. Special appliances should be provided to take care of the heavy parts of the modern types of engines so that they can be handled quickly and economically, and with the least unnecessary delay. Portable cranes should be provided to handle cylinder heads, pistons, crossheads, steam chests, rods and other parts which are required to be handled when repairs are being made. A drop-pit of suitable dimensions should be conveniently located." In a word, suitable appliances should be supplied and kept in order if work is to be done as it should be done.

#### Staybolt Breaker.

Our engraving shows a staybolt breaker operated by compressed air which is used in the Columbus, Ohio, shop of the Hocking Valley Railroad, of which Mr. J. W. Howland is general foreman. The breaker is, roughly speak-

The air inlet valves are so placed that one man can operate the tool, and he stands near the front where the placing and action of the machine are easily controlled. There is a short cylinder at the back of the apparatus which is used for air storage and is the main valve chamber. The long 2 in. cylinder on the side of, and parallel to, the machine is for the purpose of holding the apparatus against the staybolt and to automatically pull the machine up to the next bolt or rivet, as the case may be.

When the striking piston has delivered its blow and is to be brought back into position, air is introduced in front of it and although some of the air escapes through the tool socket, the pressure is sufficient to carry it back and the hand valve is at once closed. The staybolt breaker is a very efficient shop appliance and is spoken of in the highest terms by Mr. W. H. Laughridge, the foreman of the boiler shop. It is a time

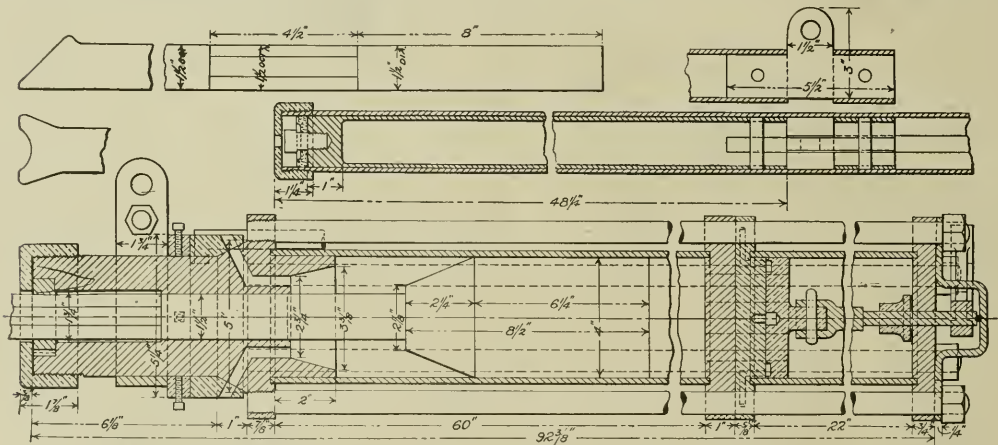

STAYBOLT BREAKERS USED IN THE HOCKING VALLEY BOILER SHOP AT COLUMBUS, OHIO.

eration of the engine, that he give this work close attention and care, and when reporting work it should be done in an intelligent, comprehensive manner, specifying clearly whenever possible the particular parts that are defective, or which require repairs. By doing so the work of the terminal or engine house forces will be materially reduced, excessive delays at times avoided and engines will be kept more regularly in service."

In the matter of special appliances and tools required, we agree with Mr. James that "in order to carry on the work on good lines and in an expeditious manner, it is necessary to have a sufficient number of machines, located conveniently near or in the roundhouse, to take care of the machine work that is required to be carried on at a terminal point. Of course, the number and class of these machines will vary ac-

ing, a cylinder something over 7 ft. long and about  $5\frac{1}{4}$  ins. in diameter. It is suspended by a chain from an overhead crane or other convenient point of support, the clips to which the chain is attached are placed near its ends. The heads of the cylinder are held by six rods outside, screwed into the front head and with nuts on the back head.

The main cylinder is 4 ins. in diameter and is fitted with a heavy solid piston which when in motion can strike a very heavy blow. There are six vents at the front end which allow the easy escape of air in front of the piston as it moves forward. The point of the cutting or breaking tool is beveled something like the end of a crowbar and is also slightly curved so that when it is placed against a staybolt it will be driven squarely against it and there will be no chance of a glancing or sidelong blow struck.

saver and easily pays for its cost of construction and maintenance.

The Canadian Westinghouse Company, Ltd., has been awarded a contract by the Montreal Street Railway Company for a large amount of apparatus. This was necessitated by the rapidly growing traffic of that company. The order included 20 quadruple equipments of railway motors complete with controllers and details; also a 1,000 K. W., 600 volt, direct current engine type generator for installation in their main power house, and three 500 K. W., three-bearing, motor generator sets consisting of type C motors and 550 volt direct current generators. These latter are similar in capacity to those now installed in their various sub-stations, which feed directly into the trolley circuits.

# General Correspondence.

## Once Laughed At, Now Used.

Editor:

In the May number of your interesting magazine you speak of the Walschaert valve gear as used by the late Mr. Wm. Mason, and that "sentiment among the M. M.s was decidedly opposed to the motion." This is true, but the work done by this valve motion did not agree with the "sentiment" of the M. M.s, as it is to-day doing good work on some of the Mason bogies. The trouble was that anything new was not looked on with favor, and often good ideas were condemned without a trial. When the air brake was first introduced on one of our Massachusetts roads, an engineer of that road said it was not worth "hell room." The idea of hitching another engine on his boiler was "damn nonsense." The air brake is still with us, but the engineer who did not approve of it is on a farm.

Looking backward, it is funny to recall the opinions of men. Mr. Mason's bogie was objected to because he used the back driver for his main crank pin, but the Atlantic type of engine is geared up the same and is here to stay. Mr. Mason's flexible steam pipe was another object of derision. It does well with a reasonable amount of care and attention. Mr. Mason used the Walschaert valve gear on his bogies because he had to, in some cases, not from preference. The bogie was made fun of because of its many parts, but the Mallet engine discounts the bogie for pieces.

HERBERT FISHER.

Taunton, Mass.

## Washing and Repairing Boilers.

Editor:

Mr. Davey's letter on Cruelty to Boilers, which appeared in the May issue of RAILWAY AND LOCOMOTIVE ENGINEERING, was interesting as far as a happy faculty for finding fault was concerned, but in the more important matter of applying a remedy for any existing evil, it could, I think, be improved upon. He seems to be peculiarly fortunate in being able to constitute himself into a committee of one and make inspection tours from Lake Erie to the Gulf of Colorado for the purpose of observing the conditions on other roads, and his opportunities are to be envied.

The next time he goes on his rounds he should tell the hostler at the clinker pits to set the injector going and let it run as long as it likes, then blow off the remaining steam. Let the boiler washer then attach the hose and fill the

boiler through the check. Open the blow-off cock and let the water run until it is cold enough to bear touching with your hand. Then remove the plugs and proceed to wash the crown sheet, making an effort to get the scale removed down the sides of the water chamber and avoid washing the matter toward the flues.

As to the caulking of flues, they should

The idea advanced by Mr. Davey that a boiler should be completely cooled five or six hours before a boiler maker is called on to make repairs is entirely erroneous. The crystallization that naturally sets in with extreme coldness is not calculated to render the metal in a condition for fine caulking, which is literally a bending of the metal. Extreme



PUTTING JUST A LITTLE WHERE IT WILL DO MOST GOOD

be bored out with augers long enough to reach from end to end. The caulking should be done while the boiler is warm. Plugs should be used in cracks, and a copper plug is a good thing where the metal is worn thin. The expander should be handled very carefully in tightening flues that are leaking badly. A slight leak may be closed by using a well fitting beading tool.

heat is much preferable, but men should not be allowed to work in an atmosphere of more than 110°, and nothing is better than to commence operations while there is some heat left in the boiler, and use the blower moderately to carry off the gases and cool the air while the boiler maker is at work.

J. R. HUNTER.

Wilmington, Del.

**Elevation on Railroad Curves.**

*Editor:*

The curve and all that pertains to it is highly interesting to every railroad man, but particularly so to the engineer. As we frequently hear curves spoken of as a 5°, 7°, or a 10°, it may be well

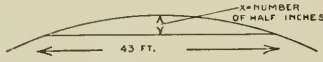

FIG. 1. CHORD OF CURVE, GIVING DEGREES.

to specify in particular what is meant when a curve of a certain degree is mentioned; this knowledge will be appreciated by many who have never taken the pains to find out just what a degree of curvature means.

Referring to Fig. 1 we have an illustration of a 1° and a 2° curve; the curves are continued until they form complete closed circles, as any curve will do if it is long enough, and is continued to the point of its origin. By definition a one degree curve is a portion of the circumference of a circle having a diameter of 11,460 ft.—something over two miles in diameter.

A two degree curve is formed in same way by a circle 5,730 ft. in diameter, in like manner a 10° curve, by a circle 1,146 ft. in diameter, etc. In engineering works, the radius, one-half of the diameter, is used as the unit of measure instead of the diameter, thus: a one degree curve has a radius of 5,730 ft., and by dividing 5,730 ft. by the number of any particular degree, the corresponding radius for that curve will be found.

A simple method for ascertaining the degree of a curve is used by trackmen, and it is sufficiently accurate for all practical purposes. A line 43 ft. long is drawn taut on the inner side of rail and the distance from middle of line to rail is measured with a rule; every ½ in. corresponds to one degree of curvature, and on some roads where ½ in. elevation of outer rail per degree is considered about right this method gives the amount of elevation required by the curve at the same time. See Fig. 2.

The correct elevation of the outer rail on curves is not a simple matter; it depends on the gauge of the track, the degree of the curve and the rate of speed of the train in miles per hour, and while the elevation increases in direct proportion to gauge and degree of curvature, it increases as the square of the train speed—60 miles per hour requiring four times the elevation that is correct for 30 miles per hour.

For the use of those who wish to calculate the elevation for curves the following engineer's formula is given: Let  $V$  equal miles per hour,  $g$  the gauge of track expressed as feet and decimals of a foot (4.7 ft. for standard);  $e$ , eleva-

tion of outer rail in inches;  $r$ , radius of curve in feet; then,  $e = \frac{V^2 g}{1.25 r}$  will give the elevation required.

In other words, multiply miles per hour by itself and multiply this product by the gauge; divide this final product by one and one-fourth the radius, and you have the inches of elevation required for a particular gauge, curve and rate of speed. This nice calculation on paper, has to be greatly modified in practice, for the elevation that is correct for the express speed of 60 miles per hour, will not do for the freight that is running at 15 miles per hour; further, the elevation has to be built up gradually on straight line where it is not wanted, so that it will be effective on the curve where it is really needed. On many reverse curves, it may be necessary to drop 4 ins. in elevation on one side and build it up on the opposite side, where there is less than 100 ft. of straight line

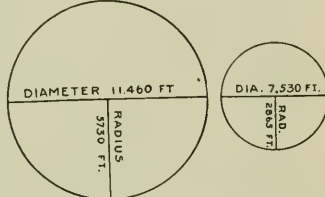

FIG. 2. DIAGRAM OF CURVES.

connecting the "S" curve; therefore, a compromise must be made, and if practice and theory fail to go hand in hand in extreme cases, the liberal minded, practical engineer can easily grasp the why and wherefore, if he will.

T. H. REARDON.

North Adams, Mass.

**Eccentric Blade Bender.**

*Editor:*

In order to appreciate the merits of our "blade bender and twister" one

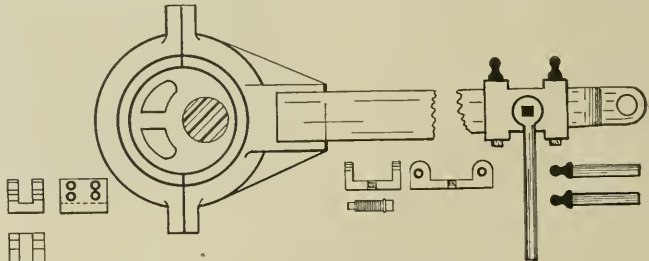

ECCENTRIC ROD BENDER OR TWISTER.

should have the tool in use in a shop or roundhouse. One can, however, gain some idea of its value by studying some of the following uses in bending and twisting different parts of the machinery of a locomotive without having to heat them or remove them from the engine.

This blade bender, as it may be called, is invaluable in bending or twisting eccentric blades, rocker arms, reverse levers, reach rods, etc. Space does not permit my going into details concerning each case of bending and twisting, but I can say that this appliance has proved a time and money saver on the "Frisco."

The sketch of the apparatus that I have made is, I hope, sufficiently clear to show it as we have it in our shop on the St. L. & S. F. It is simple and is easily adjusted. The pressure which can be exerted by it is very great. Any required amount of "set" can be given to an eccentric rod or other part, to which it may be applied, and when it has done its work it can be at once removed by slacking the set screw and withdrawing the round pins which have been slipped in through the holes in the upper and lower flanges of the holding piece.

JOHN F. LONG,  
Gang Foreman.

Monet, Mo.

**Cause of Engines Slipping.**

*Editor:*

In the April number of RAILWAY AND LOCOMOTIVE ENGINEERING, I read with interest the article by Mr. E. C. Allen on the "Cause of Engines Slipping." I should like to add a little to what has already been said on the subject and bring out a point or two that have not been mentioned thus far.

I can agree with the writer in all he says on the theory of sliding friction. He is also correct in my opinion in saying that, other things being equal, large wheels will have a less tractive power than small ones, but they have greater resistance to slipping. Now, the tractive effort of a locomotive decreases directly as diameter of the drivers increases, while the resistance to slipping increases directly as the diameter of drivers increases. That is, if the diam-

eter of drivers is doubled, tractive effort is only half as great, while resistance to slipping is doubled. Thus, resistance to slipping increases just as fast as tractive effort decreases, when diameter of drivers is increased, other things being equal.



When it comes to engine slipping because of the lifting action of main rod, it seems to me Mr. Allen is in error. When a locomotive is at rest there is a certain weight on drivers and a certain weight on trucks; the sum of the two is the total weight of the engine. This total weight will not be changed if pressure is admitted behind pistons, although distribution of weight between drivers and trucks will change. It must be remembered that when one pair of drivers slip, all slip. Referring to the sketch, let *P* be the piston in the cylinder and *C* the crank at about the lower forward eighth, engine running forward as indicated by arrow. When steam is admitted behind piston the thrust is transmitted by the piston rod to the crosshead. For the sake of clearness let us represent the forces we have to deal with by the lengths of lines drawn to some scale; in this way we can picture to the eye the magnitude and direction of all forces acting. Then let us assume that *AD* represents the magnitude of the thrust at the wrist pin. This thrust is transmitted to the wheels by the connecting rod. By the parallelogram of forces the thrust along the rod is *AE*, while thrust against upper guide is *AF*. Now, the force *AE* is transmitted to crank pin *C* with no loss, so that force *CM*, shown within the wheel in the sketch, equals force *AE*. At this point I presume Mr. Allen resolves this force into one at right angles to crank, which produces rotation, and into a thrust along crank. This thrust along crank may be resolved into a horizontal force which produces pressure on back pedestal jaw and a vertical force which, as he says, tends to lift driver from the rail and allow slipping. This resolution of forces is correct, as the three component forces may be again combined to give the original single force. We must not stop here, for the force at right angles to crank may also be resolved into horizontal and vertical forces, the latter tending to increase pressure of driver on rail. Now this downward force is much greater than the lifting force, so the net result of steam pressure is an upward force at guides and a downward force at main driver. It seems to me that Mr. Allen must have neglected this latter downward force in arriving at his conclusion that there is a lifting action, although I may be wrong in my analysis of his reasoning.

There is a simpler way to resolve the force *CM*. Let us take this thrust at the crank pin *CM* and resolve it at once into horizontal and vertical forces, as shown by sketch. By the parallelogram of forces, the horizontal force is *CK*, which is equal to the original piston thrust *AD*, the vertical force is *CH*, which is equal to *AF*, the up-

ward thrust on the guides. If the crank were on the forward dead point, the valve being open the lead, it is clear that there would be no vertical force, but all straight horizontal thrust which produces pressure on the back pedestal jaw.

It is clear that with crank anywhere below center line of engine, there is a vertical force tending to produce pressure on rail at main driver and an equal force pressing up on guides. As guides are nearly directly over trucks, this upward force reduces weight on trucks by the same amount that downward force increases weight on main drivers. Thus the total weight of engine is unchanged, but distribution of weight between wheels is effected by cylinder pressure.

Now, assume crank to be above the center and about the back eighth, as shown dotted. The main rod is now in tension due to steam pressure on piston and there is now an upward force,

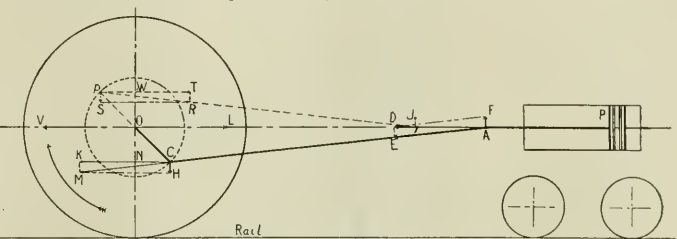

DIAGRAM SHOWING FORCES ACTING A DRIVING WHEEL.

*IJ*, against upper guide at crosshead and an equal downward force, *PS*, at crank pin as before. So that again, weight on front of engine is less, while weight on main drivers is greater than when there is no steam in cylinder. The shorter the main rod as compared with crank the greater the vertical forces acting, and, of course, they vary with position of crank, being greatest just before the quarters and zero at the dead points. Thus it is seen that weight on drivers is always increased, except at dead points, by steam pressure in cylinders and this causes a greater resistance to slipping and not a lifting effect which would aid slipping.

It is clear that we must look farther to find why engine slips on lower forward eighth, and perhaps next month I will endeavor to give an explanation of the cause.

Boston, Mass.

**What Was the Matter?**

Editor:

For the benefit of the readers of RAILWAY AND LOCOMOTIVE ENGINEERING, I hope you will give my question which you printed last month your kind at-

tion. Many men lose confidence in the compound on account of little lessons like the one referred to. In the question I stated the facts as nearly as I knew them. But I wish to say further the h.p. cylinder packing was blowing, separate exhaust and L. P. valve were tight, or fairly so. The L. P. steam chest safety valve was adjusted too high and evidently stuck to its seat. As L. P. side was in position to have the valve blanked, I figured that steam leaked past h.p. piston, filled the receiver and equalized, leaving the engine helpless until the safety valve relieved the back pressure on the high pressure piston sufficient to move L. P. side off the center, hence the rabbit jump.

There may be other causes. I hope you will find time to consider this question and insert such mechanical terms as are needed, and in other ways put this letter in shape to correspond with the rest of RAILWAY AND LOCOMOTIVE a few other frolics of the cross com-

pound that would be of interest to many engineers if properly explained.

L. L. MOSBACH.

*E. Grand Forks, Minn.*

[Your explanation of the cause of the "rabbit jump" is probably correct. The leaking high pressure piston was the trouble, and when the L. P. steam chest relief valve opened the back pressure in the cylinder partially escaped, and the throttle being opened the high pressure piston moved the engine off the L. P. center, then the contents of the receiver rushed into the L. P. cylinder and the engine jumped. Send us another "compound frolic."—Ed.]

**Filling Boiler While Being Towed.**

Editor:

I noticed in your May magazine that Mr. E. B. Thrall says that in filling a boiler while being towed, the important thing is to plug up the exhaust nozzles. Why does he plug his exhaust nozzles? Would not he accumulate pressure in the boiler when exhaust nozzles are plugged? And what position does he have his reverse lever in while being towed, and how does he pump the air out of the boiler with the nozzles plugged?

R. L. SEAVITTE.

Clancy, Mont.

TECHNOLOGY.

### General Foremen's Association.

At the second annual meeting of the International General Foremen's Association, held recently in St. Louis, Mr. C. A. Swan, Jr., first vice-president of the association, made the opening speech. He said:

We cannot do a very great amount of work this morning, but we ought to hold a session and talk over what we intend to do. I do not know that any speeches will be in order, but I want to tell you just how the association has been progressing since we last met. The membership has been increasing all the time. I think the week before last we had ten new members, and, perhaps, four last week. In nearly all the railroad shops from here to St. Paul, and around by Kansas City and the Burlington Route, I visited a great many of the shops, and the foremen were all wanting to come.

The association, I think, has had more notice than any one organization that was ever effected in the same length of time. There is not a mechanical paper published to-day but has had some notice of the association, and I want to see it one of the greatest organizations there is, and we have men to make it so. We cannot make it a success unless we attend the conventions. I think that out of some 30 letters that I wrote personally I got 25 replies, and from men who were not members.

In reply to some 52 letters I wrote, they stated that they would be here if I could arrange for transportation over some of the lines, but, unfortunately, the letters got here too late, or I would have seen the officials and arranged transportation for them, if possible. Hereafter, at our next convention, it should be the duty of some of our officials to try to get for members holding a receipt for dues, transportation over the division of their respective roads, and in regard to foreign roads the president of our association should take that matter up and see what can be done.

I do not think there is any railroad official who would refuse to grant a pass to a general foreman or a roundhouse foreman to attend one of these conventions, but the question of going East for a convention; that is the greatest stum-

bling block. After you get east of Chicago it is pretty hard to get transportation except over the Erie. The Erie will grant transportation any time, and if they don't they will give you about the best rates I ever heard of. It is a little less than three-quarters of a cent a mile. I have talked with a great many officials, and they are all in favor of the association and they want to see it progress.

I visited a roundhouse and had a talk with the foreman. I asked him how he was getting along, and he said: "Finer than silk, but I am having all kinds of trouble." They allow me \$1.10 for handling my engine; we are paying \$1.30 for labor here, and \$1.80 up town. I stood and watched the engine go over the asphalt and into the house, and I



SOME MEMBERS OF THE SINCLAIR CLAN.

Reading from left—Angus, Alexander our Correspondent, Lady Sinclair, Miss Margaret, Mrs. Alexander and Sir William.

figured it up. It cost \$1.18 to put that engine in the house. That may look unreasonable to some who have modern devices, but that man had to lie to make his repairs show. Another item that he brought to my attention was that he was not allowed to work overtime. An engine had to be got out and it was necessary to work overtime. He did just the same as you or I would have done, he worked overtime. The consequence was, if the man's name was Smith, he put it in as Fay and gave him a discharge ticket and he drew the money. The rate man knew his name wasn't Fay, and the foreman was branded as a thief. With an association like this all such cases could be taken care of. I do not say that we should organize on the basis of

a machinists' union, but we should take these things up so that the railroad officials would have it brought to their notice that there are things they have not looked into. They make as much as they can and make the poor foreman suffer for it. From the way the organization is increasing and the number that is coming in all the time, there is no reason why, by next year, we should not be stronger than any organization.

We certainly are getting the endorsement of the railroad men all over the country. We are even getting members from the Pennsylvania. I wrote to one of the superintendents of motive power on the Pennsylvania Lines and explained the object of the organization and asked him to kindly endorse it on his line. That is one of the ways that we will have to get endorsed on several of these roads that do not approve of anything like this. As far as I can say, they have been very liberal and helped us out. I know that the majority of you have written to different foremen, because I have met the foremen and they have shown me the letters. I think I now have 385 letters that were all written for the good of the association. I do not wish to take up any more time before the opening of the association, but would like to hear from some of the rest of you.

### Tractive Effort of a Motor.

The torque of an electric motor is practically the pull, in pounds, which a cable would give if wound on a drum so that the center of the cable is 12 ins. from the center of the drum which is keyed to the armature shaft of the motor. The word "torque" comes from the Latin "torqueo," "I twist."

The tractive power of a locomotive, whether steam or electric, is practically the amount of drawbar pull, in pounds, which it can develop. Newton's third law of motion is, briefly, that action and reaction are equal and opposite, and if a locomotive gives a drawbar pull of 20,000 lbs., it must have something to pull against, like a man with his feet on the ground, and, in the case of the locomotive, that something is the friction between its wheels and the rails it stands on.

If the torque of a motor is, say, 25,000 lbs., and the driving wheels of the locomotive are 48 ins. in diameter, and supposing the motor turns the driving wheels without the aid of any toothed gear wheels, the problem is practically one of levers. In this case the power is 25,000 lbs., and, multiplied by 12, the radius of the armature, gives 300,000. This, divided by 24, the radius of the driving wheels, gives 12,500 lbs., and that is the tractive effort of the locomotive. If we had taken the diameter of the driving wheels, instead of the

radius, we would have to have multiplied the torque by 24 instead of 12, but the result would have been the same.

If, however, the motor is a geared one, the formula has in it a fraction which takes the toothed wheels into account. In the formula the first fraction is the same as in the previous example, torque 25,000 lbs., multiplied by 24, divided by 48. This result must now be multiplied by the fraction having to do with the toothed wheels. Suppose the pinion to be 10 ins. in diameter and the gear wheels 30 ins. The formula then becomes

$$T = \frac{25,000}{1} \times \frac{24}{48} \times \frac{30}{10}$$

and the tractive effort here works out 37,500 lbs.

Let us now suppose that there is a frictional loss of 20 per cent. in the toothed wheels, run at the high rate of speed which these motors usually are.

The general formula for the tractive effort of a direct driving motor is

$$T = \frac{\text{torque} \times 24}{\text{dia. driver}}$$

and the formula for a geared motor is

$$T = \frac{\text{torque} \times 24}{\text{dia. driver}} \times \frac{\text{dia. gear wheel}}{\text{dia. pinion}} \times \text{gear efficiency}$$

#### 4-6-2 Passenger for the N. & W.

Away down South in Dixie, the Norfolk & Western Railway crosses a division of the great Allegheny mountain range called locally the Cumberland mountains. The company have recently secured five passenger engines of the 4-6-2 type for service over these mountains on the run between Roanoke and Bristol. They were built by the American Locomotive Company at their shops situated in the good, old historic city of Richmond, Va.

desired reserve capacity, even with extra cars on the train.

The full tractive power of a locomotive is only used in starting and in accelerating. The larger proportion of its work is performed while cutting off early in the stroke. Large boiler capacity is required to maintain steam pressure under such conditions as are met with in hauling heavy trains at relatively high speeds. Thus, with less weight on driving wheels, better work has been done with this type than with the ten-wheel engine.

This Norfolk & Western machine is a simple engine with 20x28 in. cylinders, with direct motion piston valves, 68 in. driving wheels and a calculated tractive effort of about 28,000 lbs. The engine carries a boiler pressure of 200 lbs. The driving wheels are all equally spaced, being 72 ins. apart, and all of them are flanged. The driving springs are overhung, with jointed hangers and the

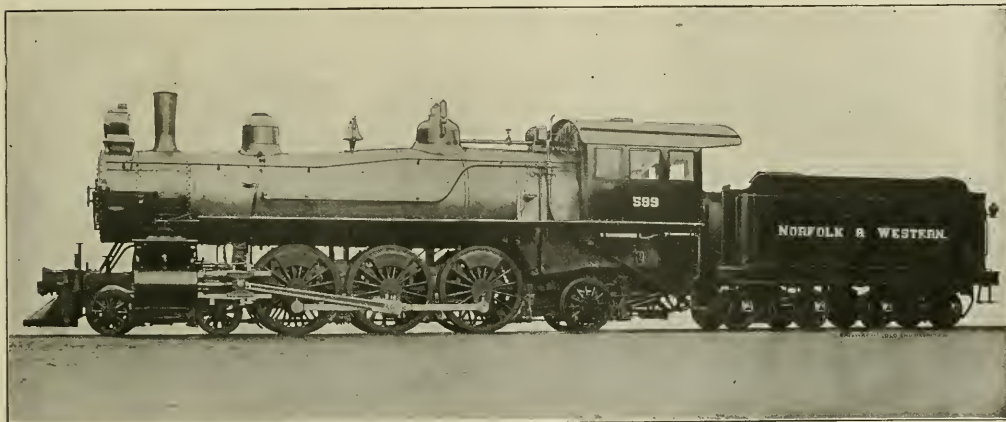

SINGLE EXPANSION 4-2-6, FOR THE NORFOLK & WESTERN.

W. H. Lewis, Superintendent of Motive Power.

American Locomotive Works, Builders.

We have the gear factor as before, 30 divided by 10, and now the gear efficiency fraction,  $\frac{8}{10}$ , as well. If there is 20 per cent. of the power used up in simply turning the toothed wheels, they will give out, as useful work 80 per cent. of the power put into them and the train of toothed wheels is said to have a gear efficiency of .8 or  $\frac{8}{10}$ . The formula now is

$$T = \frac{25,000}{1} \times \frac{24}{48} \times \frac{30}{10} \times \frac{8}{10}, \text{ or } 30,000 \text{ lbs.}$$

The fraction representing the toothed wheels, when used in the formula, will give the same result if the radius of the pinion and that of the gear wheel be taken, or if the number of teeth in each are taken, but in any case the gear efficiency is one of the factors. It must be remembered that the value of the pinion will be in the denominator of the fraction, and that of the gear wheel will be in the numerator.

These locomotives were designed for a special passenger run, and with a view of securing increased boiler capacity. They haul heavy through passenger trains which had previously been hauled by ten-wheel locomotives having the same size cylinders and driving wheels as the Pacific type engine which we illustrate. The ten-wheelers were slightly heavier on their drivers, but had a very much smaller boiler than the new engines. The 4-6-2 type was selected in this case in order to develop an engine which would not only haul the trains, but would more readily maintain the required speeds on the mountain grades. The larger boiler capacity needed seemed to be difficult to secure with the ten-wheel type of locomotive, and this is the reason for the selection of this type with its well-known ability to provide a large boiler. The results have been successful in supplying the

equalizers are between the upper and lower frame bars. The weight of the engine itself in working order is about 195,250 lbs., and of this about 125,000 lbs. rests on the drivers. With the tractive effort given above and the adhesive weight, the ratio between these figures is as 1 is to 4.47.

The trailing truck is equalized with the rear drivers, by means of a box-shaped equalizer which contains a semi-elliptic spring, the band of which acts as the pivot point. The trailing truck is provided with side motion rollers, in order to admit of sufficient play to easily go round curves and yet bring it back to the central position when running on straight track. The three point hangers used in the leading truck perform the same function though they are perhaps somewhat more rapid in their action.

The boiler of this engine is one of the extension wagon top type, the first ring

of which is 67 ins. outside diameter. The gusset sheet, which is the middle one in the boiler, gives a slope of  $7\frac{3}{4}$  ins. up to the dome course. The flues are 297 in number,  $2\frac{1}{4}$  ins. outside diameter, and are 20 ft. 1 in. long. These give a heating surface of 3,286.2 sq. ft. When added to the  $177\frac{1}{2}$  sq. ft. of fire box surface, the total comes up to 3,463.7 sq. ft., and this is equal to the area of a strip of track enclosed between the rails of standard gauge road, and about 737 ft. long. This engine if running at the rate of 60 miles an hour would require a little over 8 seconds to run over an area of track equal to its own heating surface. It might be interesting to the fireman looking ahead some night over the road illuminated by the electric headlight to mentally estimate the num-

capacity is 10 tons. The weight of the engine and tender is about 305,150 lbs., and the total wheel base for both together is 54 ft.  $11\frac{1}{2}$  ins. The principal dimensions of this engine are as follows:

Wheel Base—Driving, 12 ft.; total, 30 ft.  $6\frac{1}{2}$  ins.  
 Axles—Driving journals, main,  $8\frac{1}{2}\times 10\frac{1}{2}$  ins.; others,  $8\frac{1}{2}\times 10\frac{1}{2}$  ins.; engine truck journals, diameter,  $5\frac{1}{2}$  ins.; length, 10 ins.; trailing truck journals, diameter,  $8\frac{1}{2}$  ins.; length, 14 ins.; tender truck journals, diameter,  $5\frac{1}{2}$  ins.; length, 9 ins.

Boiler—Fuel, bituminous coal.

Fire Box—Thickness of crown,  $\frac{3}{8}$  in.; tube,  $\frac{1}{2}$  in.; sides,  $\frac{3}{8}$  in.; back,  $\frac{1}{2}$  in.

Pump— $9\frac{1}{2}$  ins. R. H.; reservoir,  $30\frac{1}{2}\times 36$  ins.

Tender Frame—Channel steel.

Valves—Travel,  $6\frac{1}{4}$  ins.; steam lap,  $1\frac{1}{4}$  ins.; ex. lap, none.

Wheels—Material, cast steel; engine truck, diam., 33 ins., cast iron; trailing truck, diam., 42 ins., cast steel; tender truck, diameter, 33 ins., cast iron.

it, and that a flat car designed especially for the purpose would have to be constructed. Accordingly, orders were placed with the West Milwaukee Car Shops of the Chicago, Milwaukee & St. Paul Railway, of which Mr. A. E. Manchester is superintendent of motive power, and Mr. J. J. Hennessy, master car builder, and it was under their supervision that Mr. J. F. De Voy, the mechanical engineer, designed, the car, and, as a result, two sixteen wheel flat cars of 200,000 lbs. capacity were built, and they are the first of their kind in existence.

A few of the details showing the unusual sizes of these new cars, are as follows: Length over end sills, 40 ft. 2 ins.; width over side sills, 8 ft. 9 ins.; height, rail to floor, 4 ft.  $4\frac{1}{2}$  ins.; wheel base, 36 ft. 2 ins.; wheels, diameter, 33 in.

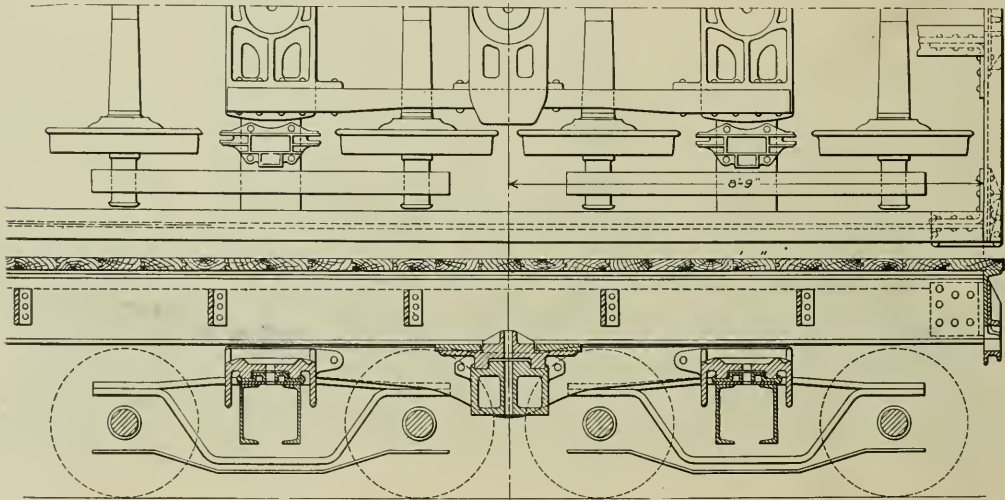

DOUBLE TRUCK ARRANGEMENT WITH CRADLE, FOR HUNDRED TON CAPACITY FLAT CAR.

ber of telegraph poles in view in the seven hundred odd feet of track of which we have spoken. He might then get some idea of the surface which he has to keep hot in the 599 class here illustrated.

The fire box is  $99\frac{1}{8}$  ins. long by  $64\frac{1}{4}$  wide, with straight side sheets. The water spaces are ample. A cross section of the fire box would show the mud ring to be  $4\frac{1}{2}$  ins. wide at the sides and a longitudinal section of the boiler would make clear the 5 in. width of the mud ring at the front end of the fire box. The grate area in this fire box is  $45\frac{1}{2}$  sq. ft. The back sheet slopes in about 27 ins. at the top and the crown sheet slopes also slightly to the front, giving, however, a steam and water space of about 24 ins. above the crown.

The tender is made with the ordinary U-shaped plan of tank. It holds 6,000 U. S. gallons of water and the fuel ca-

#### One Hundred Ton Capacity Flat.

The question of adequate carrying facilities for heavy engine parts has become more and more persistent with the growth of the present tendency toward giant electrical units. The cars used heretofore for the purpose have been especially constructed of heavy material and with a capacity of from sixty to seventy tons. This type of car is, in fact, similar to that employed by the government for the transportation of ordnance. A new problem in transportation, however, confronted the Allis-Chalmers Company in the case of a huge frame and slide for a monster horizontal rolling mill engine. This single piece, which in the rough casting weighed approximately 133 tons, was considerably over one hundred tons as a finished part. In seeking a suitable means for shipping such a casting it was learned that no single car had ever been built capable of carrying

standard; journals,  $5\frac{1}{2}\times 10$  ins.; weight of car, estimated, between 50,000 and 60,000 lbs. The cars are built as low as possible to allow all the clearance space obtainable.

The car is made with four sills, being heavy, rolled steel I-bars, 15 ins. deep, and weighing 100 lbs. to the foot. The center sills are spaced  $12\frac{1}{2}$  ins. between webs. Heavy friction draft gear is used, so placed that the center line of pull is opposite the lower flanges of the I-beams. This arrangement tends to distribute the buffing and pulling strains along a stiff section of the sills and the powerful shock-absorbing qualities of friction gear add to the ability of the car to stand up to the hard service for which it has been designed. The space between the center sills and the side sills is occupied at intervals of 3 ft. 7 ins. between each by 8 in. channel bars,  $2\frac{1}{4}$  lbs. to the foot, placed transversely, and

these, in addition to forming a very strong system of lateral bracing, carry six oak stringers, three on a side, the tops of which are just flush with the upper flanges of the I-beams, and upon beams and stringers the wooden  $2\frac{1}{2}$  in. car floor rests.

The body bolster is placed 8 ft. 9 ins. from the end of the car and on it is the center plate for a cradle, the ends of which rest on the center plates of the two trucks which support one end of the car. The trucks are thus enabled to swing each about its own center, and the car body itself is able to move on the centers carried on its body bolsters. The cradle itself consists of three bolsters, one in the center and one at each end, and these are connected by two heavy cast steel side bars. The side bars are 5 ins. square at the ends, and are made deeper and narrower as they are carried forward until at the body bolster of the car they measure 4 ins. wide and 14 ins. deep. The center plate and bolster of the cradle are cast in one piece and the bearing surface is 4 ins. below the side rail level. This cradle is of such a length as to space the truck centers 8 ft. 9 ins. apart. The employment of four trucks under this car, each suitable for use under a standard 100,000 lbs. capacity car, renders repairs or renewals an easy matter, and the fact that the body bolsters are 22 ft. apart, center to center, is an additional element of strength, without causing an excessive overhang at the ends.

The body bolster construction of this

lbs. to the foot, the lower flange of which is cut away a short distance at the center in order to accommodate the coupler shank and the place of the cut away end sill flange is supplied by a heavy malleable iron casting which not only takes the place of what would ordinarily be the carrier iron, but acts as a very substantial stiffening piece on the end sill

which describes Pacific, or 4-6-2, type passenger engines built for various railroads. The pamphlet opens with a description of this type, and gives an outline of its special advantages for very heavy and fast passenger service. These are stated very briefly, and are followed by a description of two forms of trailing truck which have been used

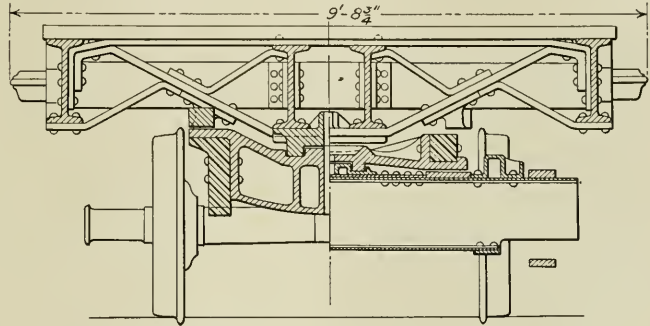

CROSS SECTION SHOWING BODY BOLSTER AND TRUCK CRADLE.

outside the center sills. The corners of the car are braced by flat plates 1 ft. wide by  $\frac{1}{2}$  in. thick, riveted to outside and end sills. The corner where side sill and end sill meet is covered by a heavy malleable iron ribbed angle plate with push-pole pocket.

As the car is supported upon two broad center plates, and these are each connected by the truck cradles with two

with great success on this type of locomotive. Then come two pages of tables, containing, in condensed form, the leading dimensions of all the locomotives illustrated in the pamphlet. By the use of side elevation and sectional drawings a typical Pacific type locomotive is illustrated, and engravings of outside and inside bearing trailing trucks are also given. The remainder

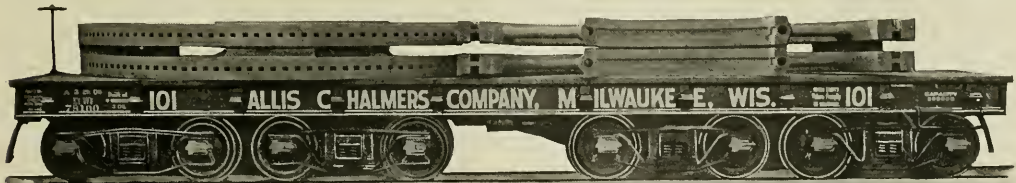

SPECIAL FLAT CAR, 200,000 POUNDS CAPACITY.

car is shown in one of our illustrations. It consists of two plates each 10 ins. wide by 1 in. thick, so placed that their adjacent edges are 12 ins. apart. These plates, of which there are four, with their ends conforming to the angle of the web and flange of the side sills, are two of them carried over the center sills and two are carried down below the flanges of the center sills, and these are strongly supported by the use of similar plates placed so as to form a system of strong diagonal bracing. The end sills are made of 15 in. channels, 55

other center plates over the truck center, the clearance between side bearings is necessarily very small in order to eliminate any tendency to rock. The cars have been given a practical test as far as their ability to curve is concerned and one of them passed easily round a 16 degree curve. The design all through is unique, and the construction simple and at the same time most substantial.

#### Pamphlet About 4-6-2 Type.

A pamphlet has just been issued by the American Locomotive Company

of the pamphlet is devoted to half-tone reproductions of locomotives, the opposite pages containing tabular information concerning each design.

This is the first of a series of catalogue pamphlets which are to be issued by the American Locomotive Company, and these will include all the standard types of locomotives, and will thus constitute a record of the company's work. Those who desire to secure one of these catalogues on the 4-6-2 type should write direct to the company.

# Railway and Engineering

A Practical Journal of Railway Motive Power and Rolling Stock.

Published Monthly by

ANGUS SINCLAIR CO.,

136 Liberty Street, New York.

Telephone, 984 Cortlandt.

Cable address, "Loceng," N. Y.

Glasgow, "Locauto."

## Business Department:

ANGUS SINCLAIR, President.

FRED M. NELLIS, Vice-President.

JAMES R. PATERSON, Sec'y and Treas.

## Editorial Department:

ANGUS SINCLAIR, Editor.

GEO. S. HODGINS,

JAMES KENNEDY,

J. P. KELLY,

Associate Editors.

## Advertising Department:

Eastern Representative, S. I. CARPENTER, 170 Summer St., Boston, Mass.

## British Representative:

THE LOCOMOTIVE PUBLISHING CO., Ltd., Amen Corner, Paternoster Row, London, E. C.

## Glasgow Representative:

A. F. SINCLAIR, 15 Manor Road, Bellahouston, Glasgow.

## SUBSCRIPTION PRICE.

\$2.00 per year, \$1.00 for six months, postage paid in the United States, Canada and Mexico. For other parts of the world, \$2.50 or ten shillings. Single copies, 20 cents. Remit by Express Money Order, Draft, Post Office Order or Registered Letter. Mailing address can be changed as often as necessary—always give old and new address, and if you subscribe in a club, state who got it up. Please give prompt notice when your paper fails to reach you properly.

Entered at Post Office, New York, as Second-class mail matter.

Copyright by Angus Sinclair Co., 1906.

For Sale by Newsdealers Everywhere.

## Efficiency of Autos and Locos.

A well-known automobilist put the question to the writer, "Why do they not couple the cylinder power of locomotives directly to the driving wheels without the use of side connecting rods? If that were done a locomotive could be made to run faster than the speediest automobile."

These remarks were made in the presence of several railway engineers and expert automobilists, and at once raised a discussion concerning the relative efficiency of automobiles and of locomotives. To the uninitiated it seems amazing that an automobile weighing about 2,000 lbs. should have the capacity of withstanding the shocks from power necessary to drive the car at a velocity of two miles per minute. Then it seems natural to ask the question, why can't they make the locomotive proportionately efficient? The answer to this question is, that the automobiles that have attained extraordinary speed are in reality racing machines, impracticable for use as traction producing cars, while locomotives are built to haul trains. The power-transmitting mechanism of a gasoline automobile makes it very weak in starting, a shortcoming which has prevented the gas engine

from operating railroad cars successfully, and has led to the choice of steam motors for most of the railways that have adopted motor-driven cars more than experimentally.

During the first two decades of the railway era, many railway companies considered that the development of high speed locomotives was a very important engineering problem, and locomotives with a single pair of huge driving wheels were to be seen on many railways. The very large driving wheels were the equivalent of a high-g geared automobile. It was never known to a certainty how fast the big driving wheel engines could run without a load, but there is reason for believing that some of them could have rivaled the best speed yet made by the automobile racing machines. They were, however, worthless as train pullers, and especially as starters, consequently they were not practicable units of railway motive power.

The modern locomotive is the survival of the fittest engine for the work to be done and its development has been the work of many master minds, who never deviated far from the beaten path of motive power design. Many inventors produced locomotives that differed radically from the established types, but they all were short lived.

The leading obstacle to the efficiency of the steam locomotive as a prime motor, compared with the motor operated by an internal combustion engine, is that the locomotive has to carry a heavy boiler and tender heavily loaded with water and fuel. The resistance to progression of all transportation vehicles on land is proportioned to the weight to be moved. A locomotive weighing 40 tons under ordinary conditions offers 40 times the resistance encountered by an automobile weighing one ton.

In regard to the question, why should a locomotive not use internal combustion engines and do away with the necessity for carrying a heavy boiler and loaded tender, the answer is that the internal combustion engine has not been sufficiently developed to enable it to exert high tractive power in starting, and the power of starting a load is of the utmost importance in an engine used for load-hauling purposes. A gasoline automobile cannot start itself on propulsion movement until momentum has been given to the fly wheel. That involves the use of a clutch to transfer the potential power of the fly wheel into the driving wheels and a clutch cannot be used practically with transmission of very high power. The experimenters with railway motor cars have run against insufferable difficulties in changing from fly wheel to driving wheel motion and their experi-

ments have been child's play compared with what would have to be done with gas engines comparing in power to a modern locomotive.

## Ten-Wheelers May Be Dangerous.

In our issue of last November we had occasion to comment on an accident to a passenger train on a western road, the engine of which had left the rails owing to some unknown cause. Among other things we said that this kind of accident nearly always happens to trains pulled by ten-wheel engines. We believe that the design for such an engine involves an element of danger on imperfect track, that has not received sufficient consideration.

In many cases the weight on the leading four wheel truck is so small that the wheels have nothing to keep them down when anything happens to depress the rear driving wheels. A very common case is for the back driving wheels to go down with a jolt on a pair of low joints, the front of the frame teeters up, and if there is a key in the center bolt of the truck, part of the truck is likely to be lifted off the rails.

We have received several letters from railway men commenting on this subject, and these letters fully bear out our opinion that certain designs of ten-wheel engines do not provide for sufficient weight on the engine truck to keep it down under all circumstances. One of our latest correspondents is a man, who, like all conscientious and competent railway employees, is deeply concerned, not only in the efficiency but in the safety of everything he handles which is connected with railroad operation.

Our correspondent tells us of several deplorable accidents with loss of life which happened by reason of some ten-wheel engines leaving the rails. These engines had flangeless tires on the leading drivers and keys in the engine truck pins. The remedies applied in order to make these engines safer was to put flanged tires on the leading drivers and the bald tires on the main drivers, also to increase the weight carried by the engine truck, and to remove the center pin keys. After these changes had been made, confidence in the engines was in a measure restored.

A case somewhat similar, which was part of the railroad experience of another member of our staff, shows the necessity for having sufficient weight on the engine truck. It was that of a consolidation engine, newly overhauled in the shop and turned out for temporary switching service.

This engine had a flangeless tire on the forward drivers and though the engine did very well on straight track it got off when heading into a siding. After one or two runs

off, in which no one was hurt, as the speed was always slow, it was found that the pony truck did not have sufficient weight upon it to properly guide the engine, and though the truck wheels followed the deflecting rails of the switch, the engine kept on straight ahead, the leading drivers dropped off and it was not until the second pair of drivers with flanged tires came along that the engine showed any signs of following the lead of the truck.

The remedy in this case was putting more weight on the engine truck and interposing a heavy double coil draw spring somewhat compressed, on top of the barrel of the truck center casting. The engine gave no further trouble, the additional weight on the truck permitted it to guide the engine on all the curves and switches in the yard, and the spring simply helped to relieve the equalizer mechanism of any violent shocks.

The proper distribution of weight on all the wheels of a locomotive is a matter of the greatest importance and we believe that in some instances, when ten-wheelers have been designed, in the effort to obtain maximum adhesion the weight on the engine truck has been sacrificed with disastrous results.

#### Why Do It That Way?

There are two instances of what shop foremen are sometimes compelled to do in order to keep things moving, which were mentioned by Mr. C. A. Swan, Jr., in his address when opening the second annual convention of the International General Foremen's Association at St. Louis a few weeks ago.

One of the things Mr. Swan spoke of was the fictitious cost of doing certain things, made up and shown on the company's books in order to conform to certain instructions. He spoke of the amount of money spent per engine in handling them at a terminal. The price was fixed by the company and each roundhouse was supposed not to go above the prescribed amount. If at a certain point the cost was higher than the fixed amount, the foreman was a party to the process known as cooking the accounts. The net result was that he avoided trouble and the company paid what it actually cost, though part of it was set down as repairs.

This reminds us of the criticism which an artillery officer made of the tactics often employed in his branch of the service. He said that when a battery was ordered to begin offensive operations it galloped off at a furious pace and swung into action front in gallant style. Very soon it had at least one gun blazing away at the enemy, and the whole idea seemed to be to bring the time between receiving the order and the first puff of smoke from the first gun, down to the very lowest possible

terms. He said that very often the battery was in too much of a hurry to take decent aim, and might not do any good until it settled down to business, but to fire off a gun somehow or other in the shortest possible time seemed to be the great and important thing.

The artillery officer practically said, Why do it that way? His idea was that the battery should strive to deliver the first effective blow in the shortest time, and to that end should work not in desperately hot haste, but should simply get into effective action as fast as it could. Applying this idea to the case cited by Mr. Swan, one might ask if a railway company might not with advantage consider the question, why do it that way? and as they have to pay whatever it costs to handle engines, why indirectly encourage the locomotive battery to make a false showing instead of simply working honestly and as cheaply as it can?

Mr. Swan gave another case, that of a foreman ordered not to sanction overtime, but who, in order to prevent engine failures, was compelled to have some of his men work overtime, and then covered up his tracks by fictitious names and discharge tickets. This man, like the other, falsified accounts, but until discovered he avoided trouble, and the company paid for and received the benefits of the prohibited overtime. This proceeding is, in a way, analogous to the behavior of a traveling salesman who bought himself a suit of clothes and charged it up in his expense account under several items usually considered legitimate. Before he was found out he chuckled to himself, saying, "The suit of clothes is in the expense account and the firm is paying for it all right, but they don't know it." Again the question looms large. If a railway company wants the truth, and expects efficient service, why do it that way?

#### Standard Time.

It is safe to say that it is owing to the railways that we have that time keeping arrangement all over this continent which is called standard time. The circumference of the earth is, at the equator, roughly speaking, 25,000 miles, and as the earth turns on its axis once every 24 hours, it follows that the sun sweeps over about 1,041 miles every hour. One degree of the great equatorial circle of the earth is a little over 60 miles long, and, at the rate of revolution just stated, about 15 degrees pass under central solar beam every 60 minutes.

As arranged in North America, the 75th meridian of west longitude has practically been made the one from which the other distances involved in the standard time scheme are measured.

The 75th meridian time is Eastern standard time. This meridian passes close to Philadelphia, and is near enough to New York, Washington and Ottawa to make a very satisfactory time reckoning basis for those cities.

Central standard time is that of the meridian 15 degrees farther west, which is the 90th, and this line passes through New Orleans and is a little west of Chicago. Fifteen degrees further on is the 105th meridian, which gives Mountain standard time. This is practically the time of the city of Denver, Col., and the name "Mountain" may have been chosen on account of the proximity of the Black Hills of Wyoming; also such mountains as Longs Peak, the Big Horn, and other broken spurs of the Rocky Mountain chain in Colorado. The 120th meridian gives us Pacific standard time, and this imaginary line passes through the center of British Columbia and the states of Washington, Oregon and California.

Coming again to the Atlantic seaboard, the 60th meridian west from Greenwich, the time of which is 4 hours slower than London, is called Colonial time. The meridian passes through the Gulf of St. Lawrence, between Newfoundland and Nova Scotia, and though it gives the time for some of the points in the maritime provinces of Canada, it does not pass over any land. Eastern time is 5 hours slower than that of London, and Pacific time is 8 hours slower. The standard system of time reckoning is such that points  $7\frac{1}{2}$  degrees east or west of a standard meridian use the time of that meridian. In 1883 the railways of the United States and Canada adopted the standard time system, and in addition to this, the Intercolonial Railway, and the lines west of Fort William, on the Canadian Pacific, have used the twenty-four hour system for a number of years.

Standard time was introduced into India at the beginning of this year, and the prejudice incident to any new departure in that ancient land is being gradually overcome. In fact, the British Government is doing very well in this regard, when it is remembered that in that vast Empire there are 147 distinct vernacular languages, and the immense population has never been accustomed to scientific modes of thought. The British Empire, as it stands to-day, comprises one-fifth of the earth's surface, and includes more than 400,000,000 people. Outside of the United Kingdom itself, India has a greater number of persons to the square mile than any other portion of the British Empire.

Standard time for India is 5 hours and 30 minutes faster than that of Greenwich, being 9 minutes faster than Madras time; about 24 minutes slower than Calcutta time, and about 39 min-

utes faster than Bombay local mean time.

Five hours and 30 minutes faster than Greenwich time is local mean time for longitude 82 degrees 30 minutes east of Greenwich. This meridian passes through India at about the eastern mouth of Godavery river, in the Bay of Bengal, and is near Benares, the sacred city of the Hindus, on the Ganges river. It is, roughly speaking, the center of the country, just as the 90th meridian west is with us. The time of this meridian,  $82\frac{1}{2}$  degrees east of London, is the meridian that now sets the standard time for all India.

#### Selling the Same Thing Twice.

A rather interesting point in what may be called the ethics of transportation was strikingly pointed out by Mr. H. H. Vreeland, the president of the Metropolitan Street Railway Company, of New York. Speaking of transfers, he is reported to have said that his company could afford to station an agent at 125th street and Eighth avenue and give to each downtown passenger a nickel to travel on the elevated rather than to have him take a surface car for the trip.

The meaning of this is that long distance travel and short distance travel are two very different things from a transportation point of view. Local and express trains covering the same ground, each requires the kind of passengers which makes each pay, and this principle is applicable to steam roads as well as to interurban traffic. Short distance passengers pay a fare and soon make way for a second short distance traveler, while a long distance passenger occupies a seat for a considerable length of time to the exclusion of short trippers. The sooner the long haul is made, the quicker the company gets rid of the passenger and can use their equipment a second time. A long distance passenger holds a seat which could probably be sold two or more times to short trippers while the car goes over its regular course.

#### Better Railway Service in Spain.

Spain will soon have a railway which will permit of passengers and freight between Madrid and Paris going through without transshipment at the frontier. Up to the present time the gauge of Spanish roads has not been uniform with that of other European countries and great inconvenience has consequently been experienced on the border. There has hitherto been no interchange of rolling stock in our sense between France and Spain, but solid through trains making fast time will be possible when the direct, double track line, which is now being built, is completed.

In addition to removing the incon-

venience due to transshipment and the saving of time incident to the new order of things, the new line will shorten the distance between Madrid and the French frontier on the Bay of Biscay by about ninety miles.

Spain has long suffered from high freight rates and slow trains. It is said that the cost of transporting cotton fabrics from Barcelona for a distance of two hundred miles into the interior of the country is more than the cost of shipping similar goods from England. The average speed for Spanish passenger trains has not been above twenty miles an hour. A new era in railway travel seems to be dawning on Spain and while rapid and easy communication with neighboring countries will be of great advantage to that country, the lowering of freight rates within her own borders will work in the interest of increased prosperity and will correspondingly benefit the manufacturer, the user and the railways engaged in handling the increased traffic.

#### Egypt Wants Railroad Equipment.

"The Egyptian Government is now ready to spend vast sums to put the country's railways in order. A great number of locomotives and passenger and freight cars will be ordered. The engines will come from England, as American engines are not liked. There is a chance for orders for passenger and freight cars. The supreme control of the railways in Egypt is in the hands of a board headed by the prime minister, they appointing a general manager."

This is a clipping from the New York Commercial's Weekly Industrial Supplement, and the statement that American engines are not liked, reminds us of the satisfaction which was given some years ago by the Baldwin engines which were shipped to the Soudan for Lord Kitchener's military railway in that country. Previous to the Soudan campaign, the British Government made a contract with the Baldwin Locomotive Works to supply some engines, and early delivery was such an important matter that a penalty clause was inserted in the contract. In accepting the clause the builders, however, asked that the penalty idea be made to work both ways. The British Government agreed that as they had insisted on the forfeiture of a certain amount of money for every day an engine was behind the stipulated time of delivery, they would pay a like sum as a bonus for every day ahead of the contract time which the builders should gain in delivery. The Baldwin Works built rapidly and well and received several thousand dollars as a bonus for early deliveries. The Baldwin people spent part of this money in sending a man with the engines to see them properly put together and tried in the Soudan,

and it is reported that even "K" himself expressed satisfaction at the performance of the engines.

The statement that there is a chance for American car building firms to supply some of the rolling stock for Egyptian roads also reminds us of the fact that several years ago some American steel cars were ordered by a railway in Great Britain, and the workmanship on the cars sent from here was so inferior as to cause most unfavorable comment, and for the time, at least, our friends across the water looked askance at American cars, judged by the samples they had seen.

#### Book Notices.

Questions and Answers Based Upon the Standard Code of Train Rules. By G. E. Collingwood. Published by the Train Dispatchers' Bulletin. Toledo, 1906. Price, \$1.00.

This useful little book is now in its fourth edition. It is in convenient pocket size and has 110 pages. It is intended for the use of trainmen preparing for examination, or for anyone who wishes to get a good practical knowledge of the subject. It contains the standard code of train rules for single and double track. Rules for the movement of trains on double track, without orders. Questions used in examinations with correct answers. Diagrams of hand, lamp and train signals. All the decisions of the American Railway Association on doubtful points in the train rules. It thus forms a valuable book of reference on this very important subject.

The author and publishers very truly say of it:

"We do not pretend that any book on railroading can take the place of actual experience; however, this book being the crystallization of experience, and, besides, containing authentic rulings—which experience does not furnish—makes it one of the most important books a railroad man, whether young or old, can possess. It makes examinations easy, as it is a catechism covering thoroughly every point of the Standard Code of Train Rules. No railroad man can afford to miss this opportunity to broaden his knowledge of train rules."

Twentieth Century Machine Shop Practice. By L. E. Brookes. Published by F. J. Drake & Co. Chicago, 1906. Price, \$2.00.

This book is a practical work on machine shop practice and contains with index 630 pages, and has over 400 illustrations. The first portion of the book is devoted to practical examples in Arithmetic, Decimal Fractions, Roots of Numbers, Algebraic Signs and Symbols, Reciprocals and Logarithms of Numbers, Practical Geometry and Mensuration. Also Applied Mechanics, which in-



cludes: the lever, the wheel and pinion, the pulley, the inclined planes, the wedge, the screw and the safety valve, specific gravity and the velocity of falling bodies—friction, belt pulleys and gear wheels.

Then follows some observations on properties of steam, the indicator, horse power and electricity. The latter part of the book gives full information on measuring devices, machinists' tools, shop tools, machine tools, boring machines, boring mills, drill presses, gear cutting machines, grinding machines, lathes and milling machines. It also takes up the consideration of auxiliary machine tools, portable tools, miscellaneous tools, plain and spiral indexing machines, and gives notes on steel, gas furnaces, shop talks, shop kinks, medical aid, and has a series of over 50 useful tables.

The book shows views of the latest machinery and improved belt and motor-driven machine tools, with full information as to their use and operation. It has been the object of the author to present the subject matter in this work in as simple and non-technical a manner as is possible.

Standard Electrical Dictionary. By Prof. T. O'Connor Sloane. Published by Norman W. Henley, New York. Price, \$3.00.

This book has 682 pages and 393 illustrations. It is a practical handbook of reference, containing definitions of about 5,000 distinct words, terms and phrases. In publishing the Standard Electrical Dictionary the author has adhered to what the work purports to be, exhausting the subject of electrical terms, giving each title the clearness of explanation necessary to make the understanding of it complete without unnecessary elaboration. In this work every electrical word, term or phrase will be found intelligently defined. Electricity is used in some form or other on many steam railroads, for driving shop tools and for lighting, where it is not employed as a form of motive power. The student, workman or shop foreman will find this a useful book. It is more than a dictionary in the ordinary sense. It is a book of reference. The terms are arranged in alphabetical order, and there is an index at the back in which the more important words are arranged so that ready reference to the definitions may easily be had.

"Stories of the Railroad," by John A. Hill, is a book which is now out of print. It is useless to send in orders for this book, as such orders cannot be filled. Order something else.

Somebody reaps the benefit of every advertisement. If it is not the man who pays for the space, it is his own fault.—Agricultural Advertising.

### Cause of Leaky Flues.

Mr. B. E. Greenwood, general foreman of the Seaboard Air Line Railway, at Portsmouth, Va., spoke at the recent meeting of the General Foremen's Association at St. Louis. He had studied the subject of leaky flues in locomotive operation and in dealing with the causes he spoke as follows:

Many theories concerning the cause and how to prevent leaky boiler tubes and fire boxes have been published within the past few years, and while I do not feel that I can give the subject justice, however, a few lines here may assist in solving this one important question, which is a source of annoyance and expense to railroads to-day, and with all that has been written, we still have leaky flues, cracked fire box sheets and leaky staybolts, which cause delay and demoralization of traffic due to those defects, that we need not offer excuse for again discussing the subject, which, to some, no doubt, is threadbare.

It is conceded that boiler making has made substantial progress in the past twelve or fifteen years; the materials used for boiler construction have undergone all of the improvements that chem-

perature of the smoke box. That by lengthening the flues two or three feet, the smoke box temperature could be reduced 100 degrees or more, the saving would be considerable and with any extra expense other than the cost of flues. Theoretically, everything seemed to be in favor of the increase in length of flues and nothing against it.

While I have no exact data to show the connection between the lengthening of tubes and the increase of trouble from leakage, yet, there has been considerable trouble experienced and many times the workmanship was blamed when poor workmanship did not contribute to the real cause. There are two causes calculated to make a long boiler tube leak more readily than a short one. First, there is a greater movement of the tubes in the flue sheet, since contraction and expansion is in proportion to the length of the tubes acted upon by the heat. The second cause I attribute to the supports being so far apart the tubes set up a movement in the middle which has a tendency to shake them loose from their fastenings.

Another source of weakness of the long tubes is the strain upon the fire box sheet, which is through the long distance the back fire box sheets and the forward flue sheets, caused by certain amount of expansion and contraction in boilers twenty-five to thirty feet long, the destructive effects with this length boilers is not noticeable in the boilers that are shorter, or at least seldom causes trouble on account of leakage.

The trouble often experienced by railroads from leaky tubes and fire boxes, in my opinion, is often caused by careless practice in cleaning or dumping fires with all ashpan drafts open and blower on full, drawing cold air into the heated fire box and tubes. Very often enginemen come in from a trip with fire box and flues perfectly tight, and go out with flues leaking, caused by careless fire cleaning and improper attention to banking fire in roundhouse. Too much attention cannot be given to engine when cleaning fire, and I would advocate the closing of all dampers possible, and if it could be done, placing a cover over top of smoke stack to prevent draft through flues when fire is drawn.

In sections where water is free from mineral impurities, very little trouble is experienced with leaky flues, and the only remedy for bad water is to soften it. If this cannot be done, the washing of boilers frequently and thoroughly will very materially lessen the trouble of leaky tubes. Another cause for leaky tubes I attribute to the frequent opening of the fire door in firing boilers. One remedy for this is to apply a mechanical stoker, which will remedy or reduce this trouble.



RAILWAY STATION AT BASLE,  
SWITZERLAND.

ical analysis and best practice of testing yet suggested and there is little left to chance or to what might be termed good luck. The art of manufacturing boiler tubes and boiler sheet has been brought up to a standard by tests and analysis where steel of certain physical and chemical properties may be depended on from every furnace heat, so that poor material ought never cause a failure of flues, staybolts or fire box sheets account of leaks. In view, however, of the above conditions, we find reports sent to superintendents daily from enginemen of some failures due to leaky flues, etc.

The prevailing tendency for the past five or six years is to lengthen the flues considerably more than what for many years had become an established practice. The advocates of longer flues have reasoned that the increase in length would provide means for absorbing more heat from the fire and gases, and consequently correct part of the heat that was wasted through the very high tem-

About the fall of 1905 we had considerable trouble with leaky flues on new engines as well as engines turned out of the shop after being overhauled. Workmanship received its full share of blame for this condition. I questioned the matter, however, and could not understand why the flues were tight under a warm water pressure of 20 per cent. above working pressure, and engine would stand road service for about 500 miles before leaving division and afterwards give trouble, while engines remained on this division with little or no trouble. After investigating the trouble, I found that while instructions had been issued to a pumper to fill his tank at low tide, the instructions were not being carried out, and as a result engines were being given full tanks of salt water. As the tide came in the water backed up into the creek from which the tank was supplied. After this trouble was remedied

The cylinders are  $14\frac{1}{8}$  and  $23\frac{3}{8}$  by  $25\frac{3}{8}$  ins. The high pressure ones are outside, situated under the running board, just over the rear engine truck wheels, and the pistons drive on the rear wheels. The low pressure cylinders are placed in the usual position below the smoke arch, and the pistons drive on the leading axle which is cranked. The driving wheels are  $80\frac{3}{8}$  ins. in diameter. The valves are of the D-slide type, and the high pressure steam chests are supplied by a pair of branch pipes which come through the shell of the boiler just in front of the dome.

The tractive effort of this engine, when calculated with mean effective pressure in the cylinders, assumed to be four-fifths of the boiler pressure, amounts to 19,555 lbs. The adhesive weight is 37,850 lbs., and the ratio of tractive effort to adhesive weight is therefore as 1 is to 4.48. The steam

is 59 ft. 5 ins. The weight of the engine in working order is 164,000 lbs., and with tender it comes to 296,500 lbs.

The boiler is a straight top one, with narrow Belpaire fire box. The smoke box ring measures  $58\frac{1}{2}$  ins. in diameter, and there are 139 tubes, the outside diameter of each being  $2\frac{3}{4}$  ins. The length of these tubes is 14 ft.  $5\frac{3}{4}$  ins., and each of them gives an internal heat absorbing surface of 4.73 sq. ft. The fire box measures  $39\frac{3}{8} \times 119\frac{1}{8}$  ins., and it has a grate area of 33.9 sq. ft. The total heating surface of the tubes, outside measurement, is 2,435.7 sq. ft.; the fire box gives 181.1, so that the total is 2,616.8 sq. ft.

The engine is in service between Columbus and Indianapolis, and its performance is being tabulated for comparison with similar engines built in this country. When the tests are thoroughly completed, we hope to be able

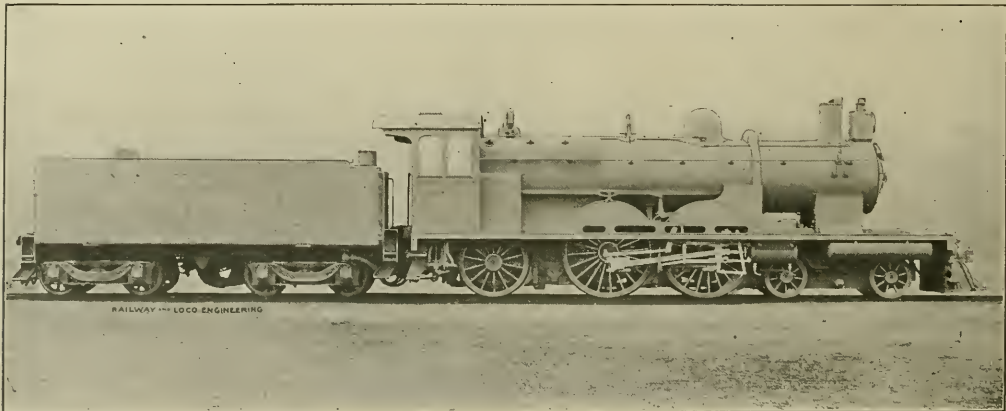

DE GLEHN BALANCED COMPOUND 4-4-2 ON THE PENNSYLVANIA.

Theo. N. Ely, Chief of Motive Power.

Builders the Société Alsacienne de Construction Mécanique, Belfort, France.

we had no more trouble with flues and fire boxes. I mention this in connection with my belief that some officials are too hasty to attribute trouble to poor workmanship before full investigation is made and definite conclusions reached.

Time will not permit me to write more on this subject at this time. For data on the temperature of fire boxes, etc., I refer you to the book written by M. E. Wells, traveling master mechanic of the Wabash Railway, "Care of Boilers."

#### De Glehn 4-4-2 on the Pennsylvania.

Some time ago the Pennsylvania determined to have one of the famous De Glehn compounds. They had it built in France and brought to this country. It is equipped with pilot, headlight, bell, and vertical plane coupler, such as is used on our railways. The engine is of the Atlantic type, and is fitted with Walschaert valve gear.

pressure is  $227\frac{1}{2}$  lbs. per square inch. The valves have a travel of  $5\frac{1}{2}$  ins. The steam ports are, for the high pressure cylinders,  $1\frac{1}{2} \times 1\frac{1}{8}$  ins., and for the low,  $1\frac{1}{4} \times 20\frac{3}{8}$  ins. The exhaust ports are  $3\frac{1}{2}$  ins. wide for each pair of cylinders, and the length corresponds to that of the steam ports in the high and low pressure cylinders respectively.

The engine has many continental features about it, such as the low running board and high box casings for the driving wheels. The position of the sand box and the substantial rod for operating it. The plate frame of the engine and engine truck. The steady brace or roller guide for the reach rod, placed on top of the rear driving wheel casing, and the arrangements for various test connections, give the engine a somewhat foreign appearance. The driving wheel base is 7 ft.  $\frac{1}{2}$  in. The total base of the engine is 28 ft.  $6\frac{1}{2}$ , and that for engine and tender together

to give the results to our readers. A few of the principal dimensions of this interesting high speed machine are appended for reference.

Size of driving axle journals,  $8\frac{1}{2} \times 9\frac{1}{16}$  ins.; diameter of wheels in engine truck,  $37\frac{13}{16}$  ins.; size of engine truck axle journals,  $5\frac{15}{16} \times 9\frac{1}{8}$  ins.; spread of cylinders,  $84\frac{1}{2}$  ins.; diameter of wheels under tender, 36 ins.; size of tender truck axle journals,  $5\frac{1}{2} \times 10$  ins.; weight of engine empty, 147,400 lbs.; weight on truck in working order, 41,250 lbs.; weight on first pair of drivers, 44,550 lbs.; weight on second pair of drivers, 43,300 lbs.; weight on trailing wheels, 34,900 lbs.; weight of engine in working order, 164,000 lbs.; weight of tender loaded, 132,500 lbs.; ratio of heating surface to grate surface, 77.1; ratio of external flue heating surface to fire box heating surface, 13.4; diameter of trailing wheels,  $60\frac{11}{16}$  ins.; size of trailing wheel axle journals,  $7\frac{3}{8} \times 9\frac{1}{8}$  ins.

For every man the world is as fresh as it was at the first day, and as full of untold novelties, too, for him who has the eyes to see them.—Huxley.

# Our Correspondence School.

In this department we propose giving the information that will enable trainmen to pass the examinations they are subjected to before being promoted. If any of our students fail to understand any part of the instructions, we will gladly try to make them plainer if they write to us. All letters intended for Our Correspondence School ought to be addressed to Department E.

## No Royal Road.

Experience is a good school, but there are few holidays, and out of the bitterness of weary days of misdirected effort, there finally comes to most men a passable knowledge of their calling. To the thinking and studious mind there are shorter roads to knowledge than the hard path of experience, though there is no royal road. The railroad man who reads our pages from month to month will learn more in one year than he will learn in ten years of toil and trial by himself, because he gets the experience of others. The injector may serve as an illustration. We publish this month the garnered facts in regard to the working of an injector, and a close perusal and careful study of the subject as presented in our pages will help any intelligent railroad man to a good working knowledge of the intricacies of this ingenious mechanical contrivance.

## Second Series of Questions.

Note.—These questions are on the injector and are numbered from 39 to 60. Those from 61 to 79 were on the lubricator and were published in May.

39. What is an injector?

A.—An injector is an apparatus in which a jet of steam condensed by water imparts to the latter its velocity, with the result that the final energy of the combined steam and water is greater than that at which the water would issue from the boiler. This difference of energy in favor of the jet passing through the injector enables it to lift the boiler check and enter the boiler.

40. In a general way, what are the two kinds of injectors?

A.—In a general way, injectors are known as "Single Tube" injectors, when they have a single set of nozzles, and as "Double Tube" injectors when they have two sets of nozzles; one of the latter kind has the function of lifting the feed water and delivering it to the forcing set, which latter imparts to the water sufficient velocity to cause it to enter the boiler.

41. What is the difference between a lifting and a non-lifting injector?

A.—A lifting injector is placed above the highest water level of the tank from which the feed water supply is taken, so that the injector has to lift the water up to its own level. A non-lifting injector is placed below the lowest level of the water of the tank from which the

feed water is taken, and it flows to the injector by gravity.

42. What are the essential parts of an injector?

A.—The essential parts of injectors are, in the first place, the nozzles, which perform the function of delivering or forcing the water into the boiler, and, in the second place, the operating mechanism, such as the lifting valve, steam valve, water valve, etc.

43. How should an injector be started?

A.—In starting an injector, if it is a lifting one, the lifting valve should be opened first, and when the water appears at the overflow, the forcing valve of the injector should be opened gradually to its full extent. In starting a non-lifting injector the water should be admitted to the injector first, and when it appears at the overflow the steam



TEN-WHEELER ON THE MAINE CENTRAL.

valve should be opened gradually to its full extent.

44. Give some of the common causes for failures of injectors to work.

A.—The most common causes for failure of injectors are the following: Leak in the suction pipe. Obstructed strainer or strainer of insufficient size. Lining up of the nozzles. Loose hose lining. Obstructions in the nozzles, such as pieces of coal, or other foreign matter washed in from the tank. Obstructions in the delivery pipe, such as a sticking boiler check which will not open properly. Leaky steam valve and boiler check, which will affect the starting of the injector by heating the suction pipe and the feed water.

45. What course should be pursued with check valve stuck open?

A.—In case the check valve is not provided with a stop valve, it will be necessary to close the heater cock and water valve of the injector, to prevent water from the boiler from running out through the injector. In this case reliance for feeding the boiler must be had on the injector, the check of which

must be in good condition. If the boiler check has a stop valve, this can be closed down to shut off the boiler pressure from the check, in which case the check can be taken out for cleaning or for the removal of the causes which made the valve stick open.

46. How may it be determined whether the check valve or steam valve is leaking?

A.—To determine whether the check valve is leaking, the frost cock, with which all delivery pipes and most check valves are provided, should be opened. If water continues to issue from this frost cock, the indication is that the check valve is leaking. To determine whether the steam valve is leaking, the cap of the heater cock and the heater cock check should be removed. If the steam valve is leaking, steam will issue through the opening.

47. What may be done in this case?

A.—In such cases the check valve and the injector must be reported for repair, and the leaky valves ground in.

48. What may be done if a combining tube is obstructed?

A.—In case the combining tube is obstructed, it must be removed, the nozzles thoroughly cleaned, and all obstructions removed.

49. How may it be determined if the trouble is on account of a leak in the suction pipe?

A.—When the suction pipe leaks, the injector works with a hoarse, rumbling sound, caused by the air drawn in through the leaks. A leak in the suction pipe may also be determined by closing the tank valve, and opening the steam valve of the injector slightly, with the heater cock closed. If there is a leak anywhere in the suction line, the steam under such circumstances will issue through the leak.

50. What should be done in case of obstructed hose or strainer?

A.—In case of an obstructed hose or strainer, the connection between hose and strainer should be broken, and, with the heater cock closed, steam should be blown back through the strainer. The water allowed to flow through the open hose will usually wash out the obstruction. In most cases it will be sufficient to remove the waste cap of the strainer, and allow water from the tank to flow through to wash out the obstruction.

51. What should be done in case the feed water in the tank is too hot?

A.—In case the feed water in tank is too hot, it will be necessary to obtain

fresh water as soon as possible to reduce the temperature.

52. Will an injector work if all of the steam is not condensed by water?

A.—An injector will not work properly if all of the steam is not condensed.

53. If it is necessary to take down the tank hose, how can the water be prevented from flowing out of a tank that has the siphon connection instead of the old style tank valve?

A.—In case a tank is provided with a siphon connection in place of the usual style of tank valve, it is better to open the air vent at the top of the pipe, in order to prevent the water from flowing out when the tank hose is taken down. The sizes of the siphon pipes are usually large enough to admit air when the hose is disconnected, so that there is little danger of the water being siphoned out of the tank.

54. Explain how the water in the delivery pipe can be protected from freezing.

A.—If the injector is not in use for a long period in cold weather, the frost cock in the delivery pipe should be opened to prevent freezing.

55. Explain how you would prevent the waste pipe freezing, either while the injector is working or shut off?

A.—The waste pipe contains water only during the short period when the injector is started, and even then it flows through the pipe at a rapid rate, so that the danger of freezing is very remote. When the injector is at rest, the waste pipe is empty. A gradual freezing as a result of a badly leaking lifting or steam valve may be prevented by occasionally opening the lifting valve slightly, and allowing steam to blow through the waste pipe.

56. How can the suction pipe and injector hose be protected from freezing?

A.—The suction pipe and hose may be protected from freezing by using the injector as a heater.

57. Explain how the heater is used on a lever Monitor injector?

A.—In connection with the lever motion injector, it can be used as a heater by closing down the heater cock and opening the lever very slightly, and fastening it in that position by means of the thumbscrew on the side of the lever.

58. How is the heater used with a screw Monitor injector?

A.—With a screw Monitor injector it can be used as a heater by closing down the heater cock and opening the steam valve spindle about half a turn.

59. Is the indication of water level by the gauge glass a safe indication if the water level in the glass is not moving up and down when the locomotive is in motion?

A.—If the water level in the gauge glass of a locomotive is not moving up and down when the locomotive is in

motion, the indication of the water level is not a safe one.

60. Is any more water used when an engine foams than when water is solid?

A.—When an engine foams, the consumption of water is undoubtedly greater than when the boiler does not foam.

61.—How should an injector be stopped?

A.—In stopping an injector, the steam valve should be pressed firmly and gradually on its seat, avoiding (more particularly in the case of a lever mechanism) the closing of the valve with a sudden shock, which injures the valve and its seat, and has a tendency to loosen these seats, where they are inserted in the body of the valve.

### Calculations for Railway Men.

BY FRED. H. COLVIN.

As an example from actual practice, let us take the skeleton throttle rigging shown and see how it figures out. Calling the throttle valve 5 ins. in diameter and the steam pressure 200 lbs., we first find the area of the valve by squaring the diameter and multiplying the 25 by .7854 which gives the area as 19.635 sq. ins. Multiplying this by 200 gives a pressure on the valve of 3,927 lbs. to overcome by increasing the leverage so that

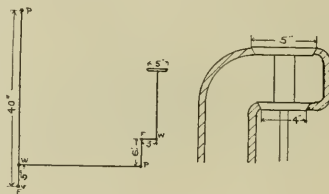

SKELETON RIG FOR THROTTLE.

a man can handle it. The bell crank lever at the right has the short arm 3 ins. and the long arm 6 ins., with the fulcrum at *F*, as before. This is a lever of the first class, just as though the lever were straight. The throttle lever itself is of the second class, because the weight is between power and fulcrum and has the weight arm 5 ins. and the total length (as well as the power arm) 40 ins. Figuring as before, we have  $FW = 3 \times 3,927$ , and this divided by 6 gives 1,963.5 lbs. as the power which must be delivered at *P*. This becomes the load for the other lever, and is transferred to *W*, 5 ins. from the fulcrum *F*.

Repeating the same operation we have  $FW = 5 \times 1,963.5$ , and dividing this by 40, the length of the power arm, we get 245.9 lbs. as the pull that an engineer must make on the throttle to open it against 200 lbs. of steam. This is more than many engineers want to handle with their good left arms, and so we can either change the proportions of the levers, making the long arm of the bell crank 9 ins., or reduce the size of the valve. Probably the former, as we are apt to

think big valves a necessity whether they are or not.

Another way out of this is to use a balanced throttle valve, one style being shown in the sketch, beside the skeleton throttle work. In this plan the steam enters the pipe, top and bottom and flows down to the left to cylinders. Calling the area of the top valve 5 ins. and the bottom valve 4 ins., it is clear that all we need to do is to balance the difference between the two areas.

We found by squaring and multiplying by .7854 that the area of the 5 in. valve was 19.635 sq. ins., and by the same method we find that the 4 in. valve is 12.5664 sq. ins. in area. Subtracting, we have a trifle over 7 ins. to balance and this multiplied by 200 is only 1,400 lbs., so that our leverage shown would reduce the pull to 87.5 lbs. If we make the lower valve  $4\frac{1}{2}$  ins. this will be still further reduced, but we do not want to go far enough to run any risk of the throttle opening too easily.

In levers of the first or second class we can take a short cut in this, by finding the proportions of the two arms and save a lot of figuring. Thus the bell crank power arm was twice as long as the weight arm, so we say the power gains two to one. Then the throttle lever is 40 ins. long (always count to the center of the handle, or where the power is applied), and the weight arm is only 5 ins. This gives a power arm 8 to 1, and as we also gained 2 to 1 before, at the bell crank, we have gained 16 to 1 in all. This tells us that we can simply divide 3,927 by 16 and get the same result, 245.9 lbs., as we did with all the figuring before. It isn't advisable to try this with levers of the third class till we are a little more sure of ourselves in problems of this kind, as there is apt to be some confusion. In the next issue we will take up some more practical applications.

## Questions Answered

BROKEN TRUCK CENTER PIN.

(49) H. I. Crossport, Dunfermline, Fife, Scotland, writes:

1. What would be the easiest and best way to block up engine in the event of a broken pony truck center pin?—A. On account of the many different designs of pony trucks and different methods of equalizing the weight carried on this truck an inspection of the truck is usually necessary to determine the quickest way of fixing up to get home. On some engines no blocking is required; but where blocking is necessary, raise up the front of the engine and block down the back end of the long equalizer to prevent the forward end from riding on pony truck axle.

## DISABLED PUMP AND BRAKE VALVE.

2. In a case of double heading, if the pump on the leading engine breaks down and the engineer's brake valve on the second engine plays out, would it be possible for the pump on the second engine to charge the main reservoir on the forward engine so as to work the brakes from the leading engineer's brake valve?—A. Yes, if such a contingency as you cite were to happen, the brake system might be charged by the pump on the second engine, and operated with the brake valve on the forward engine; but it would require the co-operation of both engineers working in concert. In case of double heading, if such a thing as the pump on the leading engine and the brake valve on the second engine failing, the better plan before proceeding would be to change the brake valves and shift the engines, having the engine in front with a perfect equipment.

## SIGNAL PIPE FOR BRAKE.

3. In the event of the train line pipe breaking on tender, would it be possible on a passenger train to operate the brakes on the train by way of the air signal pipe on the engine and tender?—A. Yes; by coupling the brake pipe hose on the engine to the air signal pipe hose on the tender, and the air signal hose at rear of tender to the brake pipe on the train, thus passing brake pipe air through the signal pipe on the tender. To do this, however, would require combination brake and air signal pipe couplings.

## GRATE SURFACE FOR BOILER.

(50) A. J., Jennings, La., asks: What amount of grate surface should a cylindrical boiler have which is 60 ins. in diameter by 22 ft. long, and has 175 tubes 2 ins. in diameter? A.—In this case you calculate the heating surface of the boiler as follows, using a ratio of heating surface to grate area of 40 to 1: The boiler, as stated in the question, is supposed to be an externally fired multitubular one and in such a case you take half the outside area of the whole cylindrical surface. The circumference of the boiler is 60 ins. or 5 ft.;  $5 \times 3.1416 = 15.7$ , multiplied by  $22 = 345.4$ , half of this is 172.7 sq. ft. The tubes are 2 ins. outside diameter and the circumference of such a tube is 6.28 and each one gives 11.51 sq. ft. of heating surface; there being 175 of them, the total tube heating surface is 2,014.25 sq. ft. This added to the surface of the half shell amounts to 2,186.95 sq. ft. Taking the ratio at 40 to 1 the grate area would be 54.67 sq. ft. See article on the horse power of boilers in another column of this issue.

## BROKEN COUPLING.

(51) H. I., Dunfermline, Scotland, writes:

What would be the easiest way to block an engine in the event of a broken deck pin or casting on the engine used in coupling the engine and tender? A.—The broken pin can readily be replaced by another pin, using the king pin of a car, and this could be taken from some empty, on a side-track, but in the event of a fracture of the casting at the pin hole or the breaking of the shackle bar, through the pin hole, no kind of blocking would be of any service. Heavy chains could be fastened to the tail brace of the engine and to the iron frame of the tender or round its center casting, and the chains could be tightened by putting a bar between them and twisting them up, then secure the bar in place when the last motion was taken up and held in place by interlocking bars.

## E T EQUIPMENT BRAKE VALVES.

(52) They are equipping these engines with the latest design of a brake valve, called symbol E T Westinghouse. Can you explain the different ways the distributing valve operates in connection with the respective positions of the brake valve? A.—A full description of the operation of the distributing valve appeared in the May issue, and an explanation of the operation of the H. and the S. F. brake valves, the kind used with the E T equipment, appears on page 265 of this issue. From those articles, we believe you will be able to obtain all the information you ask.

## STEAM TURBINE.

(53) R. W., Sayre, Pa., writes: How is a steam turbine constructed, and is there any saving as compared with an ordinary engine with reciprocating piston? A.—The steam turbine is a series of blades alternately fixed and moving, the former being attached to an outer cylindrical casing, the latter to a rotating cylindrical drum. Steam passes in the direction of the axis of the drum through the fixed blades, which deflect it so that it meets the moving curved blades tangentially, pushing them circumferentially, and being itself deflected, so that when it reaches a second set of guide blades at a reduced velocity a similar process is repeated, the steam continuing its sinuous course until it reaches the condenser. Recent experiments and comparisons made by the engineers of the steamship "Carmania" showed a gain of 5 per cent., but much larger claims are made by the builders. Professor Biles, in a recent address in London, claimed that a gain of 20 per cent. can be made by the use of the turbine.

## STEAM PIPE JOINTS.

(54) J. Y. R., Magnolia, Va., writes: What preparation is used in making joints between steam pipes and the cylinders of locomotives? A.—The essential requirements are that the faces of the steam pipes and the bearing on the saddle or cylinder should be as nearly parallel to each other as possible, the bearing on the pipe being flat and the joint on the saddle concave. Rings of brass are carefully ground to both faces, and a very thin coating of white lead and oil may be added to the joints before tightening up.

## WESTINGHOUSE PIPE VALVE SPRINGS.

(55) F. J. K., Winona, Minn., writes: Would you kindly answer, through the columns of your paper, why is it the pin valve springs of the Westinghouse plate F 7 pump governor are not cut off opposite each other? We find nearly all of them coming from the factory overlapping each other. By cutting the ends of the springs opposite each other the governor will respond quicker. A.—Probably lack of sufficient care in dressing down the ends of those springs you received accounts for their overlapping.

## K FEED VALVE.

(56) C. T. A., Leesville, Va., writes: Please answer the following questions concerning the Westinghouse K feed valve: 1. When the valve goes into closed position, and valve 14 seats, cutting off communication between train pipe and chamber G, will not the pressure in said chamber fall considerably below train pipe pressure?—A. No; if anything, it will increase, and become equal to main reservoir pressure, since this is the pressure always present in chamber B, which is separated from chamber G by a packing ring in the smaller head of piston 5, and leakage past this ring will increase the pressure in chamber G, when valve 14 is seated.

2. When in closed position does air escape continually through port h and valve 28? If so, how much air will be wasted in this manner?—A. Yes. Not very much, since port h is very small, like the warning port in the rotary valve of the brake valve.

3. What advantage has the K feed valve over the one illustrated in the November number, and what advantage has either over the slide valve feed valve attachment to the engineer's brake valve?—A. The feed valve illustrated in the November number is a design that is normally open instead of closed, as is the case with the slide valve feed valve attached to the brake valve, and this is considered an improvement. Also the feed ports are larger than in the older feed valve. The K feed valve is an im-

provement over the style illustrated in the November number, in its design for ease of adjustment, and because it does away with the necessity for a reversing cock and double feed valve where the high speed brake or the high pressure control is used. It too is normally open to feed the brake pipe.

#### LARGE AND SMALL DRIVERS.

(57) R. McR., Kingston, Pa., writes: How is it that an engine with small driving wheels can start and pull a heavier train than one with large drivers? A.—The locomotive with small drivers will pull the greater load, other things being equal, because of the greater leverage obtained from the fact that the distance from the center of the crank pin to the center of the axle is greater in comparison to the distance from the center of the axle to the rail in the case of the small wheel than it is in the large one; but it must be remembered that what is gained in strength by the smaller wheels is lost in speed. See letter on this subject in our correspondence column.

#### N. Y. NO. 5 PUMP BREAKS PISTON ROD.

(58) J. E. H., East Buffalo, N. Y., writes:

For some time I have noticed that the New York No. 5 duplex pump pounds a good deal harder when starting than the No. 2 does, and keeps on pounding until the main reservoir gets well up in pressure. Now we had a case of the piston rod breaking off just at the head, high pressure side, a few days ago, and it is my opinion the pounding is what caused it, as the pump was a comparatively new one. Am I right? A.—Partly, yes; pounding is bad for any pump piston rod, and a duplex pump never should be started, or run so fast against a low main reservoir pressure, that it will pound. In the particular case of breakage you refer to, the cause was probably poor or careless workmanship quite as much as it was heavy pounding, as the nuts might be drawn up tight but not having faces square with the piston could cause a heavy bending strain on the rod at that point that, with the pounding, would produce fracture and breakage; or the rod itself may not be turned a true taper where it enters the head, and the head may not have fitted the taper on the rod.

#### EFFECT OF HEAT ON AUXILIARY AIR.

(59) R. L. S., Clancy, Mont., writes: I have noticed on several occasions while blowing off our engines with the blow-off cock wide open that the tank brakes will set. Please explain why this happens? A.—We assume that the auxiliary on the tender is so located that the water blown out of the boiler through the blow-off cock, strikes it. This being the case, the setting of the tank brakes is caused by the air in the

auxiliary reservoir being heated by the hot water, thus causing it to expand sufficiently to move the triple piston toward the weaker brake pipe pressure and apply the brakes.

#### RADIUS OF LAP CIRCLE.

(60) J. A., Battle Creek, Mich., writes:

Will you please answer the following question, if of sufficient interest to place in your Questions and Answers Column? Referring to Fig. 24, page 44, Halsey's "Locomotive Link Motion," the line on which the center of the lap circles is found is an arc  $d'e'$ , second sentence, page 46. Please say from what radius this arc is struck, and why? A.—The arc  $d'e'$  is the arc which the center of the eccentric traverses as it is swung across the shaft by the governor,

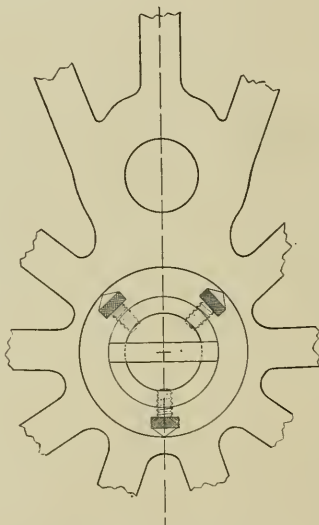

ADJUSTABLE CENTERING DEVICE.

its center being the center of the swinging movement when the crank is on the center. The arc  $d'e'$  is struck with the same radius, but with the center in the vertical instead of the horizontal center line. The laying out of this arc, in the case of a link motion, is explained on page 75. In the case of a swinging eccentric, the Bilgram diagram gives the midgear lead, whereas in the case of a link motion the midgear lead must be found from a skeleton layout of the link motion before the Bilgram diagram can be drawn.

#### Adjustable Wheel Centering Device.

At the Sedalia (Mo.) shops of the Missouri Pacific, of which Mr. S. M. Dolan is master mechanic, they have a neat little rig for getting the line between center of axle and center of crank

pin. It is used whenever this line has to be scribed on the wheel and it is of use when engines are passing through the shop for a general overhaul.

When a pair of wheels has not been accurately quartered in the first place, and it is desired to use the axles with keyways already cut in a pair of old or new wheels, the practice at the Sedalia shops is to find the amount which the old wheels were out. If the key had been out, say,  $\frac{1}{8}$  of an inch, the wheels have the keyway cut  $\frac{1}{8}$  in. over to the required side, which makes the key that much bigger than the old one and it readjusts the center line accurately so as to place the crank pins at accurate quarter turns, and the apparatus here shown makes the work of finding the true center line between center of axle and crank pin hole an easy matter.

The appliance consists of a ring of brass  $2 \times \frac{3}{8}$  ins. which fits easily inside the axle hole in the hub. Equally spaced, there are three steel set-screws pointed at their ends with milled collars back of the points. The brass ring carries a steel bridge or bar set flush with one of its edges, the bridge being  $\frac{3}{8} \times \frac{1}{2}$  in. and the center on the bridge is the center of the brass ring. The whole thing thus forms an easily adjusted hub centering device by means of which the line between hub center and that of the crank pin can be got in short order and the requisite line layed off which will bring the keyway where it ought to go in the wheel. When the work is done in wheel and axle the new key is larger than the old by the amount of the error in the original pair, but with one side milled out of the old keyway in the axle and a similar keyway cut in the wheels, the result is accurate and workmanlike, and the use of off-set keys is entirely avoided.

The Star Brass Manufacturing Company, of Boston, Mass., have removed their New York office to 70 Cortlandt street, where they will be happy to see their friends and where they will be even better equipped than formerly to handle their increasing business. They have secured more commodious quarters and the location is a good one and easy of access. The company make non-corrosive steam, water and vacuum gauges, engine registers, locomotive and marine clocks, Star improved pop safety valves, with either solid nickel or phosphor bronze seats; they also make steam engine and boiler appliances and are ready to manufacture special instruments on order.

The Order of the Thistle, one of the chief orders of knighthood in the world, was originally a Scottish order, founded in 1540. Under James II of England it was revived and remodeled in 1687.

# Air Brake Department.

CONDUCTED BY J. P. KELLY.

## Type H Automatic Brake Valve.

This is the type of automatic brake valve used with the E T locomotive brake equipment. Its general design is similar to that of the G6 brake valve, but there is considerable improvement in the method of making the pipe connections to it. These are made to the pipe bracket 5.

With this brake valve the engineer can apply the automatic brakes in the

rotary valve is such that under all conditions of service it has a more perfect balance; hence, works easily and wears uniformly.

Two views of the H brake valve are shown in Fig. 1. The one to the left is a plan, or top view, of the rotary valve seat, showing the various ports; the one to the right is a vertical section through the body, showing the equalizing discharge piston and location of the ex-

of this valve. The feed valve pipe is connected to the bracket at the point designated "Feed Valve." Air at the reduced pressure required, flows through this connection, when the rotary valve is in running position, and driver brake holding position to the brake pipe. The brake pipe connection is made at the point designated "Brake Pipe." The gauge black hand and the equalizing reservoir connections are made by means of the

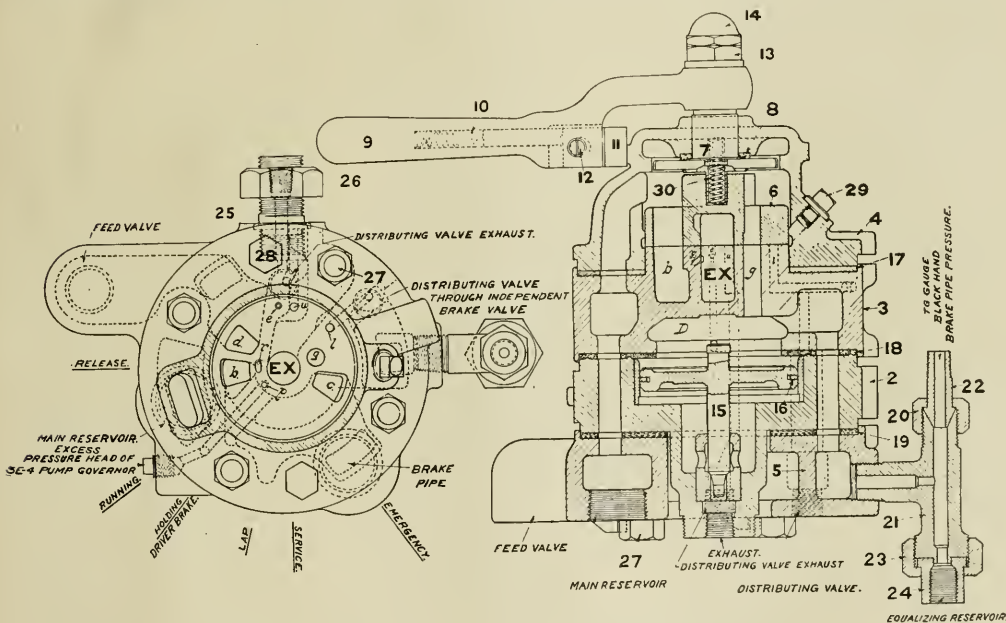

FIG. 1. H. BRAKE VALVE, AUTOMATIC BRAKE.

usual manner, and when releasing, can hold the locomotive brakes applied until danger of shock and train parting has passed; he can then graduate off the locomotive brakes, as circumstances require, in a manner that will accomplish a smooth and accurate stop.

The equalizing discharge feature in the H brake valve is the same as that in the G6, except that the volume of air contained in the equalizing reservoir is, in emergency applications, allowed to flow to the application chamber of the distributing valve, to increase the pressure therein and thus increase the pressure in all the locomotive brake cylinders, over what can be obtained in a full service application. The design of the

haust port *Ex*. A plan of the rotary valve is shown in Fig. 2, four views.

The exhaust from the application chamber through both the application chamber pipe and the double heading pipe, and that from chamber *D*, and from the brake pipe direct in service, in emergency applications, all lead into the central exhaust port *Ex*.

The pipe connections to the brake valve pipe bracket, are as follows: The main reservoir pipe direct connects to the pipe bracket at the point designated "Main Reservoir." Air from the main reservoir flows through this connection to the top of the rotary valve in all positions of the handle, and main reservoir pressure, therefore, is always had on top

T 21. The excess pressure head connection of the S. E. 4 pump governor is made at the point designated "Excess Pressure Head of Pump Governor."

The distributing valve, as already explained in the May number, has two pipe connections to the automatic brake valve; one, the application chamber pipe, is made at the point designated "Distributing Valve through Independent Brake Valve," and the other, the double heading pipe, is made at the point designated "Distributing Valve Exhaust."

Having learned the different pipe connections and their uses, as explained in the February and April numbers, the explanation of the operation of the H brake valve will be easily understood.

As shown in Fig. 1, left hand view, there are five positions for the brake valve handle; namely, release, running, driver brake holding, lap, service and emergency.

When the brake valve handle is in release position, air flows direct through the large port *a* in the rotary, and *b* in the seat into the brake pipe, and releases the train brakes, but not the locomotive brakes, since port *l*, the opening from the application chamber of the distributing valve to the *Ex*, is closed by the rotary.

The double heading exhaust pipe from the equalizing valve of the distributing valve is always closed by the double cut out cock, except when the engine is used to assist in hauling the train, and is not operating the brakes; hence, it is only when the double cut out cock is turned to cut out the brake pipe, and the brake valve handle is on lap, that the locomotive brakes can release through this pipe.

When the handle is in running position, the direct communication between

It is between running and driver brake holding positions that the locomotive brakes can be easily graduated off in the manner required by the conditions of the stop.

In lap position all ports are blanked except one; this is port *u*, the exhaust port from the double heading pipe and equalizing valve of the distributing valve. As explained above, the passage in the double heading pipe leading to this port is always kept closed by the double cock, except when the locomotive is other than the one in the train from which the brakes are being operated. When this is the case, as when second engine in double heading, the double cock is turned, closing the brake pipe and opening the double heading pipe, and the brake valve is placed on lap. This arrangement of double cock and brake valve handle provides an exhaust opening for the distributing valve, which will permit the engineer operating the brakes to release those on the other engine at the same time he does the brakes on the cars. Lap position is the one used to hold the

brake pipe pressure to take place throughout the whole train. This is the position that is used to apply the brakes in service, the same as the corresponding position on the G6 valve.

In emergency position the brake pipe port *c* is thrown wide open to the atmosphere through cavity *x* leading into *Ex*. The L-shaped groove in the face of the rotary, in this position, connects ports *g* and *l* and by this means the brake valve equalizing reservoir to the distributing valve, and raises the pressure in the application chamber about 10 pounds, assuming that the initial brake pipe pressure is 70 pounds. This gives an increase in pressure on all brake cylinders on the locomotive in emergency applications of approximately this amount, and thus add to the stopping power of the locomotive brakes, turning to good use air that formerly performed no service in emergencies.

The oil plug 29 is to permit of filling the oil bath, which consists of a small circular groove recessed in the top case 4 that surrounds the rotary and its seat at the line of meeting. As the valve is operated under pressure, the oil in the bath gradually works onto the seat and lubricates it, causing the valve to work easily and to remain free from leakage. Valve oil is the kind used in this bath, and when it is necessary to fill it, the pressure should be removed.

The spring 30 has a light tension that is sufficient to keep the rotary key 7 to its seat, when there is no air pressure to do it. This spring prevents the disagreeable blowing at this key sometimes experienced with other types of brake valves when the pump is first started.

Other ports shown in the seat of the rotary not touched upon in the foregoing are port *r*, the warning port, which is open to the atmosphere through cavity *s* in rotary and *Ex* in the seat while the handle is in release position; and port *h*, which leads to the excess pressure head connection of the SE4 pump governor. This port is closed except when the handle is in release, running, or locomotive brake holding position.

The various parts comprising the *h* brake valve are numbered and named as follows: 2, bottom case; 3, rotary valve seat; 4, top case; 5, pipe bracket; 6, rotary valve; 7, rotary valve key; 8, key washer; 9, handle; 10, handle latch spring; 11, handle latch; 12, handle latch screw; 13, handle nut; 14, handle lock nut; 15, equalizing piston; 16, equalizing piston packing ring; 17, valve seat upper gasket; 18, valve seat lower gasket; 19, pipe bracket gasket; 20, small union nut; 21, brake valve tee; 22, small union swivel; 23, large union nut; 24, large union swivel; 25, bracket stud; 26,

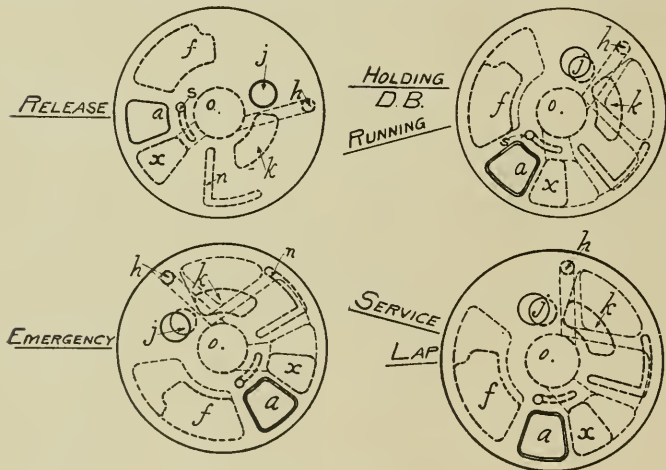

FIG. 2. VIEWS OF ROTARY VALVE.

the main reservoir and the brake pipe is cut off, and an indirect opening by way of the feed valve pipe, port *d* in the rotary seat, cavity *f* in the rotary valve, and port *b* in the rotary seat is established. Cavity *f* in the rotary, in running and driver brake holding positions, spans ports *d* and *b*, so that full communication between the feed valve and the brake pipe is had. In running position, also, port *l* is uncovered, and application chamber air can escape to the atmosphere through exhaust port *Ex*, and release the locomotive brakes.

In driver brake holding, as well as in release position, port *l* is closed, preventing the escape of application chamber air, and, of course, the release of the locomotive brakes.

brakes applied, to prevent the loss of main reservoir air in the event of a burst hose or the use of the conductor's valve, and to test the rotary valve. While in lap position, air cannot flow through the brake valve in any direction, except as explained for double heading.

In service application position, small port *e*, leading from chamber *D*, above the equalizing discharge piston, is in register with cavity and passage *h* on the rotary valve, which leads to *Ex* and the atmosphere.

In service position, the desired reduction is made from the top of the equalizing discharge piston, the same as with the G6 valve, and this piston will respond and cause an equal reduction in



bracket stud nut; 27, bolt and nut; 28, cap screw; 29, oil plug; 30, rotary valve spring.

**New S. F. Brake Valve.**

This brake valve is used with the E T equipment to operate the locomotive brakes independently.

In Fig. 3 we have a vertical section through the body of the valve showing the interior arrangement of the parts; also a top view of the rotary seat, the rotary being removed; and a plan view of the rotary valve.

The view to the left is that of the body and interior parts; the upper one to the right is that of the rotary valve, face down; and the lower view to the right is that of the rotary seat.

The pipe connections to this valve, as indicated in the lower right hand view, are as follows: The supply pipe, made at the point designated "Supply;" the automatic brake valve, made at the point designated "Automatic Brake Valve," and the distributing valve application chamber, made at the point designated "Distributing Valve."

The supply pipe furnishes air from the main reservoir, reduced in pressure to 45 lbs., to the chamber above the rotary valve 5. Hence, this pressure is always present, holding the rotary to its seat, and is the maximum pressure that can be attained in the brake cylinders in a full independent brake application.

Referring to the view of the rotary valve seat, lower right hand of Fig. 3, *b* is the supply port; *d* is the port to the application chamber of the distributing valve; *c* is the port leading to the pipe connecting the independent to the automatic brake valve; *h*, in the center of the rotary seat, is the independent exhaust port leading to the atmosphere.

The positions for the brake valve handle, as shown in this view, are release, running, lap, and service.

The operation of the S F brake valve is as follows:

With the handle in service position, the circular cavity or groove *c*, in the face of the rotary spans ports *b* and *d*, in the rotary valve seat, and air may flow direct to the application chamber until the desired pressure has been obtained therein, and the handle has been returned to lap position, and apply the locomotive brakes.

In lap position, all ports are covered, and air cannot flow in any direction through the valve. Hence, when the handle is in this position, the locomotive brakes can not be released with the automatic H brake valve.

In running position, port *b* is blanked, ports *d* and *e* are connected by means of the cavities and central passage *f*, through the rotary, and the air from the applica-

tion chamber has a continuous course through this brake valve to the automatic brake valve, where, if the handle of the latter brake valve is in running position, it can escape, and the locomotive brakes release.

In release position, cavity *g*, in the face of the rotary, connects port *d* with the central exhaust port *h*, and the locomotive brakes can release at the independent brake valve. The return spring 9 moves the handle from release to running position when the hand is removed. It is only necessary to use the release position to release the locomotive brakes, when the handle of the automatic brake valve is in other than the running position; as when the automatic brake valve handle is in running position, the locomotive brakes will release when the independent brake valve handle is placed in running position.

Under any and all conditions of brake

to the light pressure under which it operates, and its consequent freedom from wear.

The parts of the valve are named and numbered as follows: 2, Rotary Valve Seat; 3, Valve Body; 4, Pipe Bracket; 5, Rotary Valve; 6, Rotary Valve Key; 7, Rotary Valve Spring; 8, Key Washer; 9, Return Spring; 10, Return Spring Housing; 11, Housing Screw; 12, Return Spring Clutch; 13, Cover; 14, Cover Screw; 15, Handle, complete; 16, Top Nut; 17, Latch Spring; 18, Latch; 19, Latch Screw; 20, Oil Plug; 21, Upper Gasket; 22, Lower Gasket; 23, Holding Stud; 24, Holding Stud Nut; 25, Bolt and Nut; 26, Cap Screw.

**New Westinghouse K Triple Valve.**

The quick service triple, which has created so much interest among railway officials and air brake students, is shown

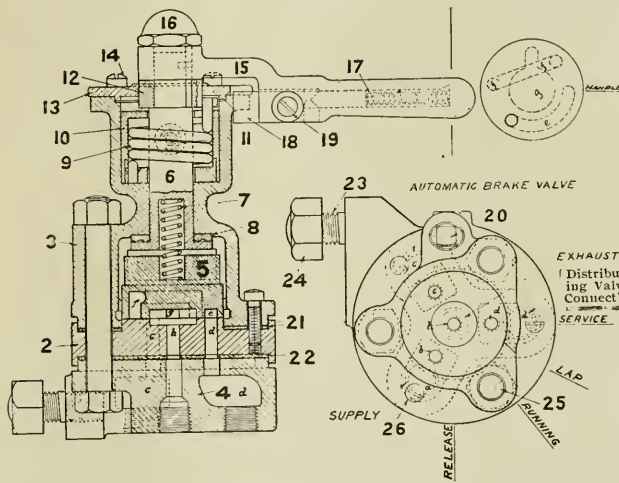

FIG. 3. S. F. BRAKE VALVE. INDEPENDENT BRAKE.

operation, the locomotive brakes may be released by placing the handle of the independent valve in release position.

This valve, like the automatic brake valve, has a pipe bracket to which all pipe connections are made and to which it is itself bolted. Hence, when it is desired to remove the valve for repairs or to apply another, it is only necessary to loosen the bolts and nuts 25 that hold it to the pipe bracket, and lift it off. No pipe joints need be disturbed. The independent valve is provided with an oil bath for the rotary and its seat, and by removing plug 20 this bath may be filled. Valve oil is the kind of lubricant that should be used.

From the drawings a very clear idea of the construction of the S F valve may be obtained; therefore, it is not necessary to say anything further regarding this feature, except to call attention

in vertical section in Fig. 4. This is the triple which gave such excellent results in the practical and exacting tests made in stopping the train equipped with it at West Seneca last August. From the drawing it will be seen that the general appearance of the valve differs but little from that of the present freight standard quick-action triple, and that the interior construction is only slightly modified.

The modifications are such that in service application a portion of the brake pipe air, which ordinarily escapes to the atmosphere at the brake valve, is diverted to the brake cylinder to assist in creating cylinder pressure, and at the same time cause the service reduction to be made more quickly along the length of the brake pipe; and when releasing the brakes they are such as will enable the engineer to release those on the rear of the train first, when it is desirable

to do so, in order to prevent shock and break-in-two.

When a service application is being made, air from the brake pipe passes up through check valve 12, port *b* in the check valve case and the valve body, port *c* in the slide valve seat and port *d* in slide valve 3, thence through cavity *w* in the graduating valve, port *j* in the slide valve and port *f* in the seat, to the brake cylinders. Ports *d* and *j* are governed by the graduating valve 7, which is of the slide valve pattern mounted on valve 3. In the release and the lap positions of the triple, valve 7 closes ports *d* and *j*.

The use of brake pipe air by the triple

shock and break-in-tuos due to slack running out.

The retarded release of the forward brakes is accomplished by simply leaving the brake valve handle in release position. The main reservoir air flowing into the brake pipe quickly raises the pressure in the forward end, and forces the triple piston and slide valve to the extreme left against the resistance of the retarded release spring 33 and stem 31. In this position the slide valve almost entirely closes the exhaust port and entirely closes the feed port *i*, leading to the auxiliary reservoir. Closing down the feed port *i* in this manner prevents

shorter stop there is a large saving in air. This saving in free air in each service application on a 100 car train amounts to 55 cu. ft.

Another important advantage had on trains either partly or entirely equipped with this triple is the uniformity with which the brakes apply throughout the whole train, and the quickness with which the release of the brakes throughout the entire train may be made. Less air being required to set the brakes, less is required from the main reservoir in releasing to restore the brake pipe pressure and recharge the auxiliaries. With trains of 100 cars equipped with the ordinary triple it is impossible to get all the brakes to apply in service. A test made to determine how many brakes would apply in service application showed that when the triples were all Westinghouse, a 15 lb. reduction applied from 76 to 81; when the triples were all New York, from 50 to 61, the equipments being 8 in. in both cases. With 10 in. equipment, the number that would apply was still less.

Hence it will be seen that the modern long trains and the methods of transportation demand a quicker acting triple in service operations and a higher economy in the use of air.

Several thousand of these triples are now in service giving the most satisfactory results; and many old triples sent to the works for repairs are being converted into the K type. The quick service triple for 8 in. equipment is known as the K-1 and that for the 10 in. equipment is known as the K-2, and these take the place of the F-36 and H-49.

In order to distinguish the K triple from the ordinary type, a lug is cast on top of the body, plainly shown in the drawing.

For lack of space we are unable to give a detailed description in this number; this, however, is hardly necessary, as the valve is so slightly changed from the present familiar triple, and these changes are clearly shown in the cut illustrating it.

#### Removing Air Pistons.

Editor:

Having seen an article in your paper last month for removing air pistons from the rods of 8-in. and 9½-in. air pumps, when stripping pump for overhauling, I would be pleased to state that, instead of using gunpowder to shoot them off, we attach a hose to the air discharge connection, remove the upper discharge valve, and force the piston down with 100 lbs. air pressure to the square inch. This pressure will remove any ordinary piston from its rod without burring the threads, and the work is easily and quickly done.

F. J. KECHFOTH, A. B. F.

Winona, Minn.

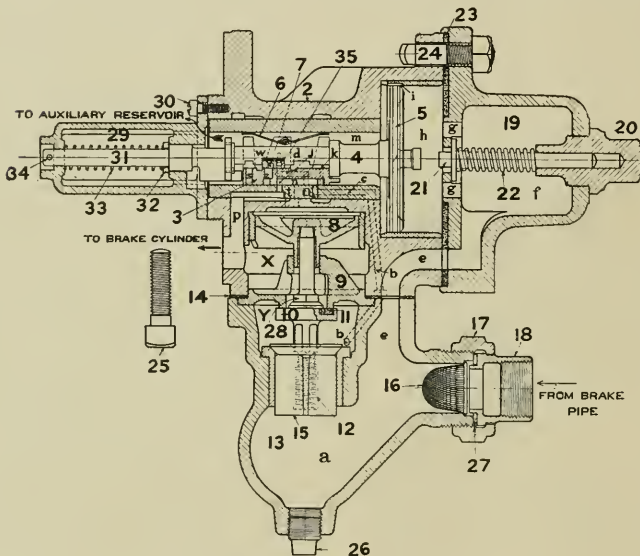

FIG. 4. SECTION OF WESTINGHOUSE "K" TRIPLE VALVE.

in service applications accomplishes several desirable things at the same time; when, for instance, a service reduction of 5 lbs. is made at the brake valve it will apply the brakes on a train of any number of cars in quick succession and with the same pressure in the last as in the first brake cylinder. To do this it uses less air and the cylinder pressure is uniformly higher than with the ordinary triple, which in turn, results in a much shorter stop. In fact, a 5 lb. reduction on a fifty-car train equipped with the K triple is the equivalent of a 20 lb. reduction on the same train equipped with the ordinary triple; and in full service application on a train of this number of cars there is a gain of 35 per cent. in the shorter stop for the new triple over the old.

When releasing the brakes on long trains at slow speeds, the rear ones may be released first, and those on the forward portion of the train be held applied for a period of time sufficient to prevent

the quick recharging of the auxiliaries on the forward cars, since they can only recharge slowly through ports *b* and *c*, and port *k* in the slide valve, which in extreme release position registers with port *c* in the seat. As a result of this action the increase of pressure at the rear of the train is hastened and the rear triples are moved to the position shown in the figure, releasing the brakes.

As the pressure equalizes in the brake pipe the forward triples assume the normal position, as shown in the figure, opening feed port *i*, and their auxiliaries will then recharge at the normal rate, finishing at the same time those on the rear finish recharging. This prevents reapplication of brakes on the forward cars when the brake valve is moved to running position and consequent loss of air in releasing them.

A service reduction of about 17 lbs. will apply the brakes in full, and hence in full service application in addition to the quicker operation of the brakes and

**Shriver's Z-Lock.**

The Z lock, or nut lock, for packing gland nuts of air pumps, is one invented by Mr. Wm. W. Shriver, A. B. I., B. & O. Railway.

The ordinary flat swab holder is bent

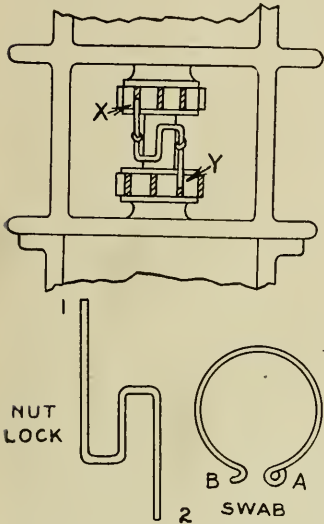

SHRIVER'S Z-LOCK AND SWAB.

to form an eye, *A*, at one end, and a half-hook, *B*, at the other end. The Z lock is made by bending a piece of heavy wire, as represented, with arms one and two. To apply the lock, put on the swab, turn it so opening faces out.

Now, take lock, slip arm 2 in eye *A*, then spring swab tightly against piston rod, and slip arm 1 over half-hook *B*. Turn gland nuts until arms 1 and 2 can each be pressed into a wrench slot.

Nuts can neither tighten nor become loose with this lock applied.

**Air Brake Test Rack.**

Editor:

Inclosed please find illustration of air brake test rack at this place, in A., T. & S. F. shops.

Beginning at the right is the brake valve and engine triple test and signal line of 12 cars, quick action and plain triple test (Westinghouse), an appliance to set cylinder relief valves, and to test the ET equipment.

At this place we overhaul 500 to 600 triples a month and make repairs on air brake apparatus from shop of 18 pits and roundhouse of 35 stalls.

I remain, an old subscriber,

A. E. NYE.

Albuquerque, N. M.

**Portable Lye Tub.**

The illustration, Fig. 5, shows the method of cleaning air cylinders, their valves, ports and passages, without removing the pump from the engine, used

by Mr. J. E. Thompson, air pump repairman, of the J. Q. & C. R. R., at Chattanooga, Tenn.

Boiling hot lye is used, which is carried in a portable tub, and pumped through the cylinders by means of the piping arrangement shown.

**Machine Shop Practice.**

A very interesting paper on Machine Shop Practice was read by Mr. L. R. Laizure, general foreman of the Erie shops at Hornellsville, N. Y., at the recent meeting of the International General Foremen's Association, held at St. Louis last month. We give the first part of the paper as follows, the part containing reference to machine tools appears elsewhere in this issue:

In writing this article, time and conditions will not permit me to make a comparison as to the cost of work with the year 1895, so I shall simply make a comparison between the shop practice of a few years ago and that at present.

One of the most essential features to be considered in shop practice is a good shop organization, beginning with the master mechanic, general foreman, machine foremen and gang foremen. The master mechanic should have general supervision over all departments of the shop, he being selected for that position by reason of his mechanical skill. He is directly held for the running of the shop and its output.

The general foreman is all that the

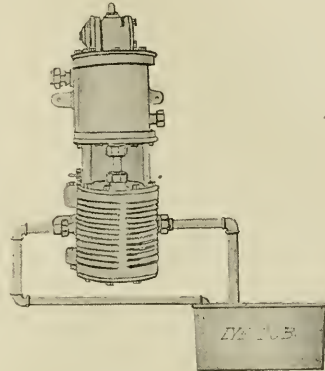
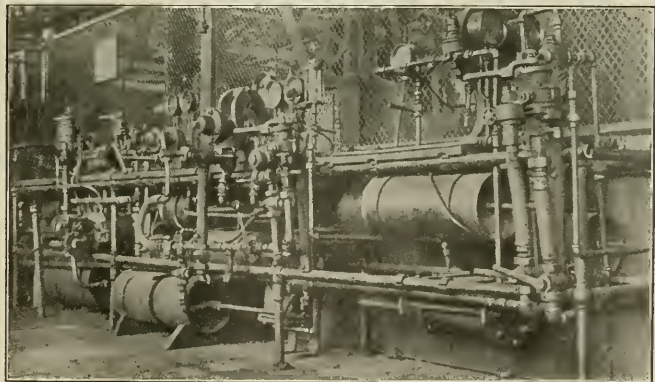

FIG. 5. PORTABLE LYE TUB ARRANGEMENT FOR CLEANING PUMPS.

that they will keep their shoulders to the wheel and keep things moving.

What is true of the general foreman is also true, in a measure, of a gang foreman, but in addition to this he must be a good manager of men and a skilled mechanic.

He must constantly look ahead over the entire work, and see that it is moved from one machine to another,



AIR BRAKE TEST RACK A., T. & S. F. AT ALBUQUERQUE, N. M.

title of his position implies. He should be a man quick to think and act, master of the situation in his shop, and should know at all times just what is going on. He should also be a good manager, not only in regard to work, but also a good manager of men. He must be active and alive to the interests of his company at all times, studying economy and practical methods of doing the work whereby a saving will result in the cost of repairs, and so organizing his forces and plan-

and from the erecting floor to the machine for the different operations; and to see that the operations are performed on the machines best adapted to the work. Gang foremen should give their undivided attention to the work in hand, and instruct their men as to the best way of doing it; also to look after the details that have a direct bearing on the output of the shop.

The most skilful foreman is not always the one that has exceptional mechanical

abilities. While exceptional mechanical ability is desirable, it is also necessary that a foreman be able to take a bird's-eye view of the situation. A man is needed who can keep the continuity of the work in his mind and bring the various factors together so that they will work out harmoniously, both as to construction and time. This qualification is especially desirable when one foreman's work is dependent upon another's. The foreman who possesses these qualifications, can truly be said to be successful.

The material question is another very important feature of shop management and practice. More time is lost by waiting for material than from almost any other cause, and to overcome this a good supply of every important article should be kept in stock. If material is handled in such a manner that the shops are living from hand to mouth, as it were, invariably it is the case that you

and weight proportionately. An engine that weighed 80,000 or 100,000 lbs. ten or fifteen years ago was considered very large, and the prediction was made at that time that they could not possibly be built any larger, but to-day we have engines weighing as high as 350,000 lbs. The tender of the modern locomotive is nearly twice the weight of the engine of ten years ago. With this increase in the size of locomotives comes the natural increase in repairs. While this revolution has been taking place in locomotive building during the past fifteen years, most railroad repair shops are in practically the same condition they were fifteen years ago, and are greatly handicapped in their output because they are not equipped with modern tools and facilities to handle the increased work.

The mechanical department is now called upon to increase the output of their shops, and at the same time to de-

The history of this product dates back over a period of but eight or ten years, and the makers of this steel, if they have accomplished nothing more, have awakened the management of repair shops to the amount of work which can be done with the new steel on the old machines.

Planer work is now done at two, three, or even four times the speed at which it was performed previous to the introduction of this product on the old machines with the old water hardening steel. The product of planers with the use of high speed steel is limited not by the cutting speed, but by the reversing mechanism of the machine itself. Modern planers have a reversing mechanism three to four times greater than the cutting speed, which greatly increases the amount of work which can be done by the machine.

The new steels have brought about a revolution among machine builders generally. The old time lathes, planers, boring mills, etc., are unable to withstand the great strain necessary to drive the new steel at its maximum capacity, but only those who can afford to throw out the old and put in the modern machines are in a position to take full advantage of the increased output to be had from the use of high speed cutting tools.

Electric traveling cranes, electrically driven machines, and high speed steel have come upon us at almost the same time, and they have done more to bring about a revolution in machine shop practice and methods than anything else that has ever taken place in the mechanical world.

#### Echoes of the Earthquake.

The details of the appalling disaster that fell on San Francisco and other portions of California are familiar to the general public, and it is not necessary to recapitulate them here.

In the immediate succor of the panic-stricken multitudes we take pride in stating that railroad men were the real heroes of the hour. Much praise has been given to the military forces, whose work it was to keep the homeless people in control and preserve from pillage what property remained. The soldiers did their duty well, as American soldiers always do, but the railway men on the ground did better. Possibly it is that railroad employees generally are accustomed to act promptly in emergencies, and few there are who have been long at railroad work but have been forced to look upon mutilation and death. Our special correspondents in California have furnished us with many interesting accounts of their experiences, and from a large number of letters we make a few selections.

At Sausalito, Mr. C. C. Stevens, of the North Shore Railroad, describes the

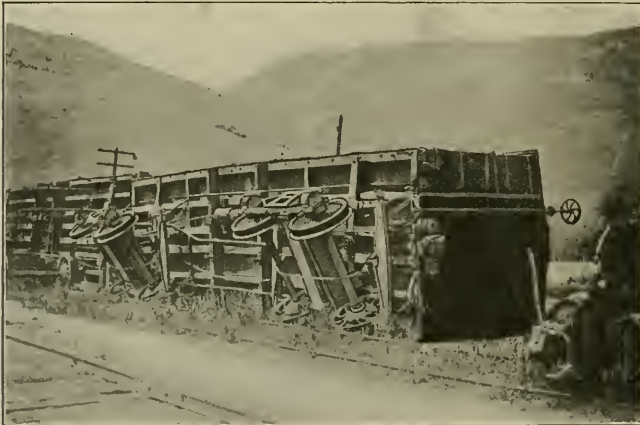

ENGINE AND THREE CARS THROWN OFF THE TRACK BY THE EARTHQUAKE.

are just out of the particular castings that you need the most.

The very earnest desire of the company to cut down interest charges on stock carried generally results in filling up your shop with engines waiting for essential parts, thereby decreasing the output of the shop and increasing the cost of repairs. The longer an engine is in the shop, the higher the cost of repairs on account of more time being charged to the engine than would be charged if there was no delay from any cause. Repairs cannot be made quickly if you have to wait for material, and an engine in the shop not only decreases the output of the shop by keeping another engine out, but it is an extra expense to the company from the fact that the engine is not bringing in any revenue.

Railroads have kept on growing for years, and engines have increased in size

and the cost of repairs to the least possible extent. In the expense of locomotive repairs, labor constitutes about two-thirds of the cost and material the remainder. This is has become very necessary for railroad managers to give considerable thought and investigate thoroughly modern shop practice and less expensive methods of doing the work. The results of these investigations have brought out the necessity of having modern improved machinery, and the adoption of some system, such as the piece work system, as a means of increasing the output of the shop at a decreased cost.

Improved machinery, with the use of high speed steel, so-called, and the piece work system, will bring about the desired results in any well organized shop. No subject has ever attracted greater interest in the machine shop world than the records made with high speed steels.

first intimation of the earthquake as a dull, rumbling sound, followed by a very perceptible rising of the earth and a settling again, followed by a swaying backward and forward, as if the earth was rocking on some vast, elemental, soft substance beneath. The motion finished with a corkscrew oscillation that was really more destructive to buildings than the undulating motion. During this terrifying period the locomotives standing in the yard rolled back and forward, and the night hostlers and the entire roundhouse crew never lost their wits for a moment, but ran hither and thither with wooden wedges, blocking the engines. The shop and buildings were badly cracked, but did not fall. The ground fell away

down with a crash. All of the oil tanks at Alameda Point were also destroyed, and a complete transfer of the shop equipment is being made to San Jose, Cal.

Mr. J. J. Foley, of Oakland, states that the shock was the best alarm clock that he ever had. Every railroad man responded without any further notice, and promptly aided in taking thousands of people to safety. Many of the water tanks were thrown down, but the heads of the departments managed to keep the road running. Nothing could surpass the service of the road in conveying the immense crowds everywhere free, and bringing back tons of provisions to feed the hungry thousands that remained. The railroad men, Mr.

clothing they had on, but they never flinched from their duty for a moment. Their work was only equaled by the generosity of the people along the road, who readily opened their doors to the suffering refugees, who did not seem to know where they were at.

From other correspondents we learn that the shops of the Santa Fe at San Francisco were considerably damaged, and through traffic delayed for several days. At San Luis Obispo the vibrations were not of so great magnitude, but the alarm among the people was very great. Railroad property was much damaged, and several days elapsed before through traffic was opened up. It is stated by a correspondent that Santa Rosa has suffered



PASSENGER 4-6-2 ENGINE FOR THE SOUTHERN.

A. Stewart, Mechanical Superintendent.

Baldwin Locomotive Works, Builders.

in many places as much as fifteen feet, and the corkscrew movement conveyed its peculiarity to many of the rails, some nearly describing the letter "S." Engine No. 14 and three cars were overturned, and many of the bridges were much damaged. The burning of San Francisco, that lasted three days and three nights, as seen from Sausalito was a spectacle of awful and unparalleled grandeur.

Mr. E. S. Shick, of Newark, Cal., tells of a narrow escape of a freight train on the Southern Pacific Railroad. A double header freight train had just stopped to take water when the rumbling commenced. The engineers agreed that they had better move away from the water tank. When the corkscrew movement began, the tank came

Foley states, were the only people who kept cool during the terrible period following the shock.

Mr. E. A. Kelsey, of Santa Cruz, states that the Coast Line division was badly damaged for nearly 200 miles south of San Francisco, much of the roadbed being sunk from one to twelve feet, many box cars on sidings being turned over, a photograph of one of which Mr. Kelsey secured, and which we reproduce in the accompanying illustration. One train of thirteen cars was completely turned over while running. Strangely enough, the extensive wooden sheds at San Francisco were saved, together with the shops and engine equipment, while everything in the vicinity perished by fire. Many of the employees lost everything but the

more than San Francisco in proportion to its size. The narrow gauge tunnel at Wright's, three-quarters of a mile long, was caved in, the mountains near Santa Rosa being violently shaken. At Eureka the sharp oscillations shook down many trees, some falling across the railroad tracks and impeding traffic.

#### Simple 4-6-2 for the Southern.

Quite recently the Baldwin Locomotive Works have built for the Southern Railway twenty large 4-6-2 type locomotives for passenger service. Fifteen of these engines have driving wheels 63 ins. in diameter, while the remaining five have 72½ in. drivers; otherwise the designs are very similar. Our illustration is from a photograph of one of the latter class. There is nothing particu-

larly novel in the design of these engines, their chief interest lies in the fact that they represent the latest development of a type of locomotive which is doing very efficient work in heavy passenger service.

The cylinders, which are of the single expansion type with slide valves, are 22 ins. in diameter by 28 in. stroke. As the steam pressure is 220 lbs., the calculated tractive power with the 7½ in. wheels is 34,955 lbs. The weight on the driving wheels is 138,460 lbs., hence the factor of adhesion is 3.96. The link motion is indirect, the rocker being placed in front of the leading drivers, and it is connected to the link by a transmission bar which spans the leading driving axle. There is a crosshead arrangement by which the upper end of the rocker communicates motion to the valve rod.

The wheels of this engine are all flanged and all the drivers are equally spaced, being 75 ins. apart. The trailing truck has inside journals, and the springs are placed between the frame bars and are back of the carrying wheels. These carrying wheels have upon them 42,300 lbs., the engine truck has 39,700 and with the adhesive weight given above, the total weight of the machine is 220,460 lbs. The driving springs are all overhung and are held by jointed hangers. The frames are of cast steel, the rear sections being separated with the splice under the front end of the fire box, which is supported at that point by a vertical plate. The trailer truck, which is of the Rushton type, is equalized with the drivers; the rear end of the engine being carried on an inverted leaf spring, which helps to secure easy riding. The main reservoir is carried on three brackets under the forward end of the running board. The cylinders have a double row of bolts in the vertical flanges and also in the smoke box. They are arranged for double front frame rails, and are strongly built with heavy walls to insure against breakage.

The boiler is of the straight top type with sloping throat and back head. It is radially stayed, with double riveted circumferential seams, the longitudinal seams being butt jointed and welded at each end. The dome ring has a welded seam on the top center, with a liner inside. The boiler is liberally provided with washout plugs, and has ¾ in. liners in the waist over the supporting guide bearer and waist sheets. The shell of the boiler measures 70 ins. diameter at the smoke box end, the tubes are 3¼ in. number and are each 20 ft. long. They are 2¼ ins. in diameter and are No. 11 gauge. The heating surface is as follows: Fire box, 195 sq. ft.; tubes, 3,683.5 sq. ft.; total, 3,878.5 sq. ft., and the grate area is 54.25 sq. ft. The total weight of the engine and tender is about 358,000

lbs., and the wheel base of both together is 64 ft. 5¾ ins.

The tender is of the usual form with steel frame, and arch bar trucks. The tank has a water bottom and holds 7,500 U. S. gallons, and carries about 25,000 lbs. of coal. A few of the principal dimensions are appended for reference:

Boiler—Thickness of sheets, ¾ in. and 13/16 in.; fuel, soft coal.  
 Fire Box—Material, steel; length, 108¾ ins.; width, 72½ ins.; depth, front, 76¼ ins.; back, 66¾ ins.; thickness of sheets, sides, ¾ in.; back, ¾ in.; crown, ¾ in.; tube, ½ in.; water space, front, 4½ ins.; sides, 3½ ins.; back, 3½ ins.  
 Driving Wheels—Journals, main, 10x12 ins.; others, 9x12 ins.  
 Engine Truck Wheels—Front, diameter, 33 ins.; journals, 5½x10 ins.; back, diameter, 42 ins.; journals, 8x12 ins.  
 Wheel Base—Rigid, 12 ft. 6 ins.; total engine, 31 ft. 4½ ins.  
 Tender—Journals, 5½x10 ins.  
 Service—Passenger.

#### Free Transportation in Canada.

In Toronto they have a system of taking up fares in the street cars by which the company usually gets all that is



"IN THE GLOAMING"; EVERYBODY ELSE AT SUPPER.

coming to them. The conductor has a locked box which is a leather covered affair with a handle on one side and a slot in the top. The front of the box is made of glass so that passenger and conductor may see what has been put in. Buttons and other substitutes for legal tender are thus easily detected. By pressing a spring the conductor can drop the coin or ticket out of sight into the cash receptacle at the bottom of the box. Then you might as soon hope to get it back as to have steam heat after the 15th in a New York flat.

An incident, related in the Toronto

News, occurred the other day which goes far to prove that the human heart is still occasionally stirred with feelings of kindness and generosity, and the way that it happened was this:

"He was on a Sherbourne street car. The gentleman was old and genial-looking, reminding one of the brothers Cherrybe, but he was very absent-minded. Accordingly, when the conductor came around to collect his fare he thoughtlessly slipped in a quarter. When he realized what he had done he was much confused. The quarter, however, was gone beyond recall, and he decided to make the best of it. The company should not profit by his mistake at any rate. A lady sitting next him was about to deposit a fare, when he excitedly laid a detaining hand on her arm.

"Don't pay! Don't pay! Your fare's paid! Your fare's paid!" he said in a high falsetto. The lady took in the situation and submitted laughingly. Not so, however, a stranger who entered the car and took a seat just opposite the old gentleman, who repeated the request. 'Don't pay! Your fare's paid!' he said. 'Sir!' said the woman indignantly, fixing him with an icy glare. He explained. 'I'll pay my own fare,' she snapped.

"The passengers were convulsed. The old man persisted, however, and was still paying fares when the writer arrived at his destination."

Thus it was that those who accepted the old gentleman's hospitality were much surprised to find that a free ride was coming their way if they were going his way, and from quite an unexpected quarter.

The Chicago Pneumatic Tool Company have issued their quarterly report for the period ending March 31 of this year. It is for the benefit of their stockholders. The business of this company is said to be ten per cent. greater for April than it was during that month last year. Mr. J. W. Duntley, the president, sailed for Europe early in May in the interest of the company's business. Conditions in Great Britain and on the Continent are said to be improving rapidly, and many large contracts which have been pending are ready to be closed, hence Mr. Duntley's trip. It is also stated that several contracts will be given to the Consolidated Pneumatic Tool Company, Ltd., of London, which is the foreign branch of the Chicago company. The contracts will be for extensive installations as well as for future requirements extending over periods from one to three years. Before sailing, Mr. Duntley stated that his company's domestic business was entirely satisfactory.

# Of Personal Interest.

Mr. R. T. Guppy has been appointed principal assistant engineer of the Union Pacific.

Mr. A. Firnhaber has been appointed roundhouse foreman on the Southern Railway, at New Albany, Ind.

Mr. F. E. Meixner has been appointed general foreman of the East St. Louis, Ill., shops of the Southern Railway.

Mr. J. F. Guggolz has been appointed roundhouse foreman at Mart, Tex., on the International & Great Northern Railroad.

Mr. Charles M. Hays, vice-president and general manager of the Grand Trunk Railway System, was recently entertained at a complimentary dinner in the Windsor Hotel, Montreal, on the occasion of his fiftieth birthday. Mr. F. H. McGuigan, fourth vice-president of the G. T. R., was at the head of the table,



CHARLES M. HAYS.

and every chief of department not away on duty was present. The tables were arranged in horse-shoe shape, no doubt typifying the good luck wish which all had for Mr. Hays. The toast of the evening was proposed by Mr. McGuigan, who congratulated Mr. Hays on attaining the half-century mark, and went on to assure him of the warm personal esteem in which he was held by every member of the staff. When Mr. Hays rose to reply he was presented with a bouquet of fifty American beauty roses—one for each year of his life—and a massive gold loving cup, suitably inscribed. He feelingly acknowledged the compliment paid him and went on to declare that whatever success he had achieved as general manager was very largely due to the honest and earnest efforts of the men who had been working with him on the official staff.

Mr. L. P. Goodwyn has been appointed master mechanic of the Texas & Gulf, with headquarters at Longview, Tex.

Mr. Joseph Shea has been appointed supervisor of water service of the Chicago, Rock Island & Pacific, at Topeka, Kan.

Mr. C. B. Hathaway has been appointed roundhouse foreman at Houston, Tex., on the International & Great Northern Railroad.

Mr. F. H. Sweringen has been appointed master car builder of Street's Western Stable Car Line, with headquarters at Chicago.

Mr. S. S. Haff has been appointed assistant road foreman of engines on the Long Island Railroad, with headquarters at Morris Park, N. Y.

Mr. W. F. Purdy has been appointed assistant engineer of the Wabash for the Pittsburgh district. He succeeds C. S. Lambie, who has resigned.

Mr. L. A. Cross has been appointed road foreman of engines of the Peoria & Eastern, at Indianapolis, Ind., vice Mr. Miles Gibson, who was transferred.

Mr. E. A. Mason has been appointed assistant purchasing agent of the Mexican Central Railway Company, with offices at 25 Broad street, New York City.

Mr. R. D. Gibbons has been appointed master mechanic of the Monterey division of the Mexican Central, to succeed George W. Cooper, who has resigned.

Mr. H. W. Menzemer has been appointed general foreman of the Louisville division and its branches, on the Southern Railway, with headquarters at Louisville, Ky.

Mr. J. J. Clark has been appointed master mechanic of the Nashville Terminal Company, with office at Nashville, Tenn., to succeed Mr. G. B. Longstreth, who has resigned.

Mr. M. J. Powers, formerly Delaware & Hudson foreman, at Binghamton, N. Y., has been promoted to the position of master mechanic, at Carbondale, Pa., on the same road.

Mr. H. S. Needham has been appointed assistant motive power inspector of the Pittsburgh, Cincinnati, Chicago & St. Louis, with office at Columbus, O., vice Mr. C. D. Young, transferred.

Mr. F. P. Pfahler, who was draftsman of the Baltimore & Ohio, at Baltimore, Md., has been appointed mechanical engineer of the Wheeling & Erie, with office at Norwalk, Ohio.

Mr. Frank Hyndman, general master mechanic of the New York, New Haven

& Hartford, has been appointed to the position of mechanical superintendent of the road, vice Mr. F. N. Hebbits, resigned.

Mr. John Deane, formerly inspector of new work, has been transferred from Chicago to Davenport, Iowa, where he now holds the position of general car foreman on the Chicago, Rock Island & Pacific.

Mr. Robert J. Gross, vice-president of the American Locomotive Company, has been put in charge of the sales department of that company. Both domestic and foreign sections are included in this department, Mr. J. D. Sawyer and Mr. C. M. Muchnic being respectively their chief officer's first lieutenants. Mr. Gross comes from the land of the Maple Leaf, having been born in the town of Brighton, Ontario, in 1850. At an early age he entered the service of the Mon-

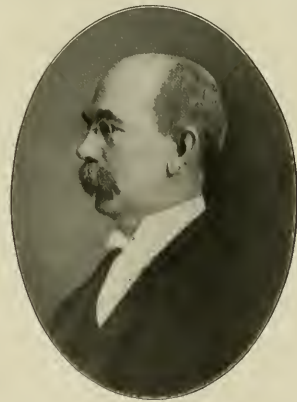

ROBERT J. GROSS.

treteal Telegraph Company, and was several years in their employ. Later he turned his attention to the more responsible duties, which come with railroad work, and after having been a station operator for some time, he was advanced the position of train dispatcher while yet a youth of nineteen years, in the service of the Erie Railroad, at Buffalo and at Dunkirk. In 1879 he became chief dispatcher on the Denver & Rio Grande, at Pueblo, Col., and that company soon after made him manager of transportation, in which position he remained until he again accepted service with the Erie in 1881. In 1882 Mr. Gross became associated with Horatio Brooks, the founder of the Brooks Locomotive Works, at Dunkirk, N. Y. He was Mr. Brooks' chief assistant and showed marked ability as a salesman for that company. The Brooks

Works advanced Mr. Gross through several important positions until he was elected vice-president of the company, and as such he remained until 1901, when the Brooks Works were absorbed by the American Locomotive Company, and he was then elected to the 2d vice-presidency of the larger concern. He remained in Dunkirk until called upon to become vice-president and the executive head of the sales department. The American Locomotive Company, in addition to the manufacture of locomotives in their 10 large building establishments, also make automobiles, steam shovels, dredges, snowplows and electric trucks, so that Mr. Gross' office in the Trinity Building, 111 Broadway, is in a sense the distributing center for a vast amount of railway and other power equipment and appliances for carrying on construction and commercial operations on a large scale.

Mr. G. C. Bishop, master mechanic of the Pittsburgh, Cincinnati, Chicago & St. Louis, Logansport division, at Logansport, Ind., has been appointed superintendent of motive power of the Long Island Railroad.

Mr. W. C. Henry, master mechanic of the Wellsville, Ohio, shops of the Pennsylvania Lines, has been transferred in a similar capacity to the Columbus, Ohio, shops on the same road, vice Mr. S. W. Miller, resigned.

Mr. F. N. Hibbits, mechanical superintendent of the New York, New Haven & Hartford, has been appointed superintendent of motive power on the Lehigh Valley Railroad, vice Mr. A. E. Mitchell, resigned.

Mr. C. D. Young has been appointed assistant master mechanic of the Pennsylvania Lines West of Pittsburgh, on the Northwest System, with headquarters at Fort Wayne, Ind., vice Mr. N. M. Loney, promoted.

Mr. W. A. Moody, who was chief draftsman of the Illinois Central, has been appointed acting mechanical engineer, with office at Chicago. He is succeeding Mr. J. H. Wynne, mechanical engineer, who has resigned.

Our honored correspondent, Mr. W. de Sanno, was in San Francisco at the time of the earthquake and passed through the tumult unscathed. His family also escaped without injury, but their house is in a bad condition.

Mr. W. F. Cox, formerly general car foreman for the C., R. I. & P., at Davenport, Iowa, has been transferred to Cedar Rapids, Iowa, where he holds a similar position on the same road, vice Mr. F. H. Sweringen, resigned.

Mr. A. C. Davis, formerly assistant engineer of motive power at Fort Wayne, Ind., on the Pennsylvania Lines, has been appointed master mechanic on the same road at Wellsville, Ohio, vice Mr. W. C. Henry, transferred.

Mr. C. M. Muchnich, of the foreign sales department of the American Locomotive Company, sailed for Europe on his wedding trip a few weeks ago, followed by the best wishes of his many friends on this side of the water.

Mr. J. T. Flavin, assistant master mechanic of the Indiana, Illinois & Iowa, has been appointed master mechanic of the Chicago, Indiana & Southern and the Indiana Harbor, with offices at Hammond, Ind., and Kankakee, Ill.

Mr. N. M. Loney, assistant master mechanic of the Pennsylvania Lines West of Pittsburgh, on the Northwest System, has been appointed assistant engineer of motive power, at Fort Wayne, in place of Mr. A. C. Davis, promoted.

Mr. F. H. Sweringen has resigned his position of general foreman on the Chicago, Rock Island & Pacific, at Cedar Rapids, Iowa, to accept the master mechanicship of the Street's Western Stable Car Line, with headquarters in Chicago, Ill.

Mr. James L. Hecox, who has been in the employ of the Chicago & North-Western Railway, Prairie du Chien division, for more than forty years, has been retired on pension, he having passed the 70th birthday while still in active service.

Mr. C. H. Mead, general car foreman of the Iowa Central at Marshalltown, Iowa, has been appointed master car builder of the Isthmian Canal Commission, under Mr. George D. Brooke, superintendent of motive power, at Ancon, Panama.

Mr. K. R. Gordon, formerly master mechanic for the New Orleans & Belt Terminal Co., has been appointed roundhouse foreman and also has charge of coach and car department for the New Orleans & Northeastern R. R., at New Orleans, La.

Mr. C. O. Keagy, general foreman of passenger car inspectors, at the West Philadelphia shops, has been appointed general car inspector, at Altoona, in place of Mr. R. L. Kleine, who has been appointed assistant chief car inspector, with headquarters at the same place.

Mr. H. F. Ball, superintendent of motive power of the Lake Shore & Michigan Southern, with headquarters at Cleveland, Ohio, has had his jurisdiction extended over the Chicago, Indiana & Southern, recently formed by the consolidation of the Indiana, Illinois & Iowa and the Indian Harbor.

Mr. W. A. Bowden, who was formerly connected with the Locomotive and Machine Co., of Montreal, has been appointed designing engineer of the Department of Railways and Canals of the Dominion Government. His duties will include the work in connection with the new shops for the Intercolonial Ry., at Moncton, N. B.

Mr. W. C. Henry, heretofore master mechanic of the Pennsylvania Lines, Northwest System, at Wellsville, Ohio, has been transferred to Columbus, Ohio, as master mechanic of the Pittsburgh, Cincinnati, Chicago & St. Louis, to succeed Mr. S. W. Miller, who has resigned to become connected with an electrical concern, at Philadelphia, Pa.

Mr. Wm. Clegg, Jr., who has been special agent of the Westinghouse Electric & Mfg. Company in their St. Louis territory, has received the appointment as acting manager of the St. Louis office, Mr. D. E. Webster, formerly manager of the office, has been transferred to a position in the Chicago sales office of the company.

Mr. Graham Smith, formerly in charge of Westinghouse exposition and convention publicity, as the New York Westinghouse press representative, and recently engaged in advertising work under his own name, will be several months abroad. On his return he will assume the direction of the Eastern advertising interests of several prominent corporations of the Middle West and West, with an office in the Flatiron Building, New York, and will make a specialty of the preparation of industrial books of the higher class.

Mrs. A. Fenton Walker, for several years the traveling representative for Wm. C. Baker, car heaters, is now the U. S. representative for the Railway and Marine World, of Toronto, Can. Mrs. Walker has also been appointed United States representative for the Directory Publishing Co., of London, Eng., publishers of the Universal Directory of Railway Officials. Her office is at 143 Liberty Street, New York. Mrs. Walker is a most energetic woman and is certain to make a success of the business she has undertaken to manage.

Mr. E. J. Burton has been appointed superintendent of the Williamsville, Greenville & St. Louis Railway, headquarters, Greenville. Mr. Burton was promoted on the C. I. & L. (Monon) in 1886, running on the Chicago & Alton and Wabash. He gave up his position with the Wabash to enter Purdue University in order to take a mechanical engineering course, remaining in college a year and a half, after which he went back to the Detroit division of the Wabash, but again left the Wabash to take a position as general foreman on the Mobile & Ohio, where he remained two and one-half years, leaving that service to go with the Fitz-Hugh, Luther Company, of Chicago, as salesman, and recently he accepted the position of superintendent on the W., G. & St. L.

Mr. W. E. Brooks has been appointed inspector of passenger service of the Missouri Pacific Railway Co., the St. Louis, Iron Mountain & Southern Railway Co., and all leased, operated and in-



dependent lines, with office at St. Louis. He is to investigate the conditions surrounding passenger train schedules; connections of depending trains on connecting lines; the through car arrangements and local make-up of passenger trains; the condition and suitability of passenger equipment and the efficiency of passenger trainmen and engineers with respect to the maintenance of schedules and the comfort of passengers.

While visiting his family at Cedar Rapids, Iowa, W. L. Harrison, formerly master mechanic of the C., R. I. & P., at that point, and now master mechanic of the Kansas division, at Horton, Kan., called at the shops for a social chat and received a pleasant surprise. A committee had been at work since Mr. Harrison's departure for his new field of labor and were prepared for just the moment he gave them. After a cordial welcome, Mr. Marshall, road foreman of engines for the Northern division of the Rock Island, on behalf of the motive power employees at Cedar Rapids, presented him with a very handsome diamond shirt stud as a token of their esteem and appreciation of his worth as a man.

Mr. W. P. Garrabrant, formerly air and steam heat inspector on the U. R. R. of N. J. division of the Pennsylvania, has been promoted to the position of general air brake and steam heat inspector on that road, with office at Altoona, Pa. Mr. Charles W. Martin has been appointed to succeed Mr. Garrabrant in the position which he has vacated. The management of the P. R. R. are to be congratulated upon their selection of men so well qualified to fill the positions to which Mr. Garrabrant and Mr. Martin have been appointed. We are sure they will discharge the duties of their respective positions with credit to themselves and entire satisfaction to the road by whom they are employed.

#### Likely to Meet

Several months ago we recorded notes of the prowess achieved as a golf player by Mr. George M. Sargent, the popular veteran railway supply man, who has retired to a well earned life of leisure. Mr. Sargent's leisure has been kept active by golf playing in which he has developed considerable skill. Like other people who acquire skill, Mr. Sargent got searching for some one to make tests on and he accidentally heard that his old friend, Angus Sinclair, had been elected president of the East Orange Golf Club. No time was lost in dispatching a challenge which was promptly accepted. They met and wrestled for the greater part of a scorching day on Orange links last month, and George carried away the scalp of his Scotch opponent, of which

he is vastly proud. Rumor has it that the Atlantic City convention will be the means of bringing these sports in conflict again and the outcome will be watched with keen interest.

#### Remarkable Record.

Editor:

Possibly one of the greatest records made by any locomotive engineer, if not an unprecedented one, was terminated with the demise of S. E. Green, who died of pneumonia at the St. Louis & San Francisco Railway Hospital at Springfield, Mo., on April 21, 1906, at the age of eighty-three years and two months, after 65 years of continuous service as a locomotive engineer. Mr. Green was born February 7, 1823, and at the early age of 15 began his railroad career. At the age of 18 he was promoted to the position of locomotive engineer, which position he has manfully filled with credit to himself and his fraternity until a ripe old age. During this time he had worked on the New York Central, the Erie and for Uncle Sam, during the war of 1861, then for the C. & A., afterwards entering the service of the St. Louis & San Francisco Railway prior to 1869, remaining with this road until his arrival at the Grand Union Station in the city beyond, from whose bourn no traveler returns.

He was revered by his companions, and tendered easy branch runs, but declined them, and constantly remained in main line passenger service, preferring the fastest and hardest runs. During the present season when the Frisco and M., K. & T. Ry. established joint mail service from St. Louis to points in the Southwest, this honored and aged veteran of the throttle played his important part for these lines, his road being awarded the mail contract over other rival lines. As the contract was to be awarded by the Government, after a series of tests had been conducted, in order to decide the preference of route, Mr. Green took one of these runs between Monett, Mo., and Sapulpa, Ind. Ter., and although the run required a speed ranging from 40 to 60 miles per hour, he was equal to the occasion and was always on time. He continued on this run, making his last trip on March 24, 1906, and afterwards was taken to the hospital at Springfield, Mo., where he died in less than one month.

While living, Mr. Green seldom laid off, and performed his most arduous duties without murmur or complaint, neither did he draw the lines closely on his own individual duties, but in many cases assisted the fireman and machinist. His standing with the Brotherhood and the company may be better appreciated and understood by saying that when the B. of L. E. General Committee of Adjustment changed

their seniority limits from district rights to division rights, March 20, 1904, Mr. Green was made an exception to the rule and was granted special jurisdiction rights, which were not accorded to any other engineer on the system, and when he was sent to the hospital, he was not forgotten by his fellow workers, as many of them called to see him. Mr. C. R. Gray, second vice-president and general manager, sought to comfort him, which, no doubt, was the grandest compliment that an official could extend to an employee under such circumstances.

In conclusion, I would say that this aged veteran of the throttle was as spry and active as a boy of sixteen, capable of reading his orders daily, without the aid of glasses; although he carried them with him, he seldom used them, except in lamp light. I believe that your readers will agree that sixty-five years of continuous service as an engineer, together with successful running on high speed trains at the age of eighty-three, is a remarkable record, which will stand as a monument and tower high over any that may be made with other hands, and set to adorn or mark his grave.

J. R. SCOTT,  
Sapulpa, I. T. R. F. of E.

#### Obituary.

It is with sincere regret that we have to record the death of Frank Roach, the well-known trainmaster of the South Platte division of the Chicago & North-Western Railway, at Fremont, Neb. Mr. Roach's personality was such as to make him a loved and respected officer of the company and his associates and many friends sincerely mourn his loss.

#### Turbine Locomotives.

Mr. L. Wilson, of Greenock, Scotland, has devised a method intended to overcome the difficulties met with in applying turbines to locomotives. The locomotive bogie axles are extended on the outside of each wheel, and the turbine wheels and casings are mounted on the projecting axle ends. The steam pipes and exhaust pipes connecting with the cylinders and the smoke stack of the locomotive are connected by swivel ball and socket joints to the casing. Mr. Wilson's intention is that the turbines shall be driven by the exhaust steam from the locomotive cylinders, and the turbine valves are operated by the same links and levers as those which control the forward and reverse movement of those of the steam cylinder.

A press dispatch from Portage La Prairie, Man., says: The first rails of the Grand Trunk Pacific were quietly laid here early in May. The company have opened yards to the west of the town and this will be the center of distribution

of supplies during construction. Extensive yards will be laid out here, and there will be a large amount of sidings.

Marine Engineering, which has been so prosperous under the management of Mr. H. L. Aldrich, has taken on an addition to its name, and now holds forth as International Marine Engineering, and on July 1 of this year it will be published in London, in the shape of the European edition, simultaneously with the American edition, published in New York.

#### Simple vs. Compound Locomotives.

At the April meeting of the Western Railway Club there was a most interesting meeting that was principally occupied with the discussion of a paper presented by Mr. J. F. De Voy, mechanical engineer of the Chicago, Milwaukee & St. Paul, making a comparative test between a simple and compound locomotive based on a thesis submitted for the degree of bachelor of science by four students in mechanical engineering of the University of Wisconsin. The Chicago, Milwaukee & St. Paul Railway Company had given these students the privilege of making comparative tests of two locomotives, and the work was entered into with the elaboration and zeal characteristic of such opportunities. All the paraphernalia necessary to carry on such tests was provided and all the elaboration of experiment conceived by the most severe processes of mental segregation were employed to impart luster to the tests.

The conclusion of the report was that the compound engine did its work with a saving of 4.35 per cent. over the simple engine.

In talking upon the paper, Mr. Manchester, superintendent of motive power of the C., M. & St. P. Railway, said that the compound engine is one in which the stich in time is a great factor. It is not a good engine to turn loose and let go to destruction. It is not a good engine to undertake to keep in repair from your main shops. Any railroad that does not maintain a thorough and efficient roundhouse organization had better keep entirely out of the way of compound engines, because the compound engine requires attention when it needs it, and it is not a wise proposition to put it off until to-morrow when it does need it.

This opened the way for a discussion on the relative merits of simple and compound locomotives in which Mr. W. E. Symons, who generally throws clear light on any engineering problem he discusses, took a most masterly part in analyzing the performance of the two classes of engines. As Mr. Symons discussed every salient point of the paper, we reproduce the leading portion of his re-

marks as far as they apply to the relative engineering value of the two classes of engines:

Mr. Symons spoke as follows:

In looking over the fuel characteristics there seems to be no advantage favorable to either engine. The fixed carbon averaging 44 per cent. for the compound and 42.8/10 for the simple, while the B. T. U. were within ten degrees of same, the volatile matter, moisture and ash being approximately equal. The exact and precise ratio of stack and ashpan refuse shown, seems a little unusual in road tests.

It may be observed that, notwithstanding there was a slight difference in temperature of feed water, favorable to the simple engine, yet the temperature of escaping gases from the compound engine was about ten degrees lower than

so, where separate supply of fuel was carried for switching purposes and terminal consumption.

There is much to commend in this paper to those interested in the subject, as it furnishes much food for thought, not only to those especially interested in the relative merits of the compound vs. simple locomotive, but to the railway engineering world in general. While Mr. De Voy's paper, as I have already stated, is very interesting, indeed, having brought out a number of good points, yet in some respects it shows final results obtained, that to myself, are very disappointing, leaving me very much in the dark on a very important question. And in order that I might not be misunderstood by any who is here this evening, or who may read the proceedings of this club, I wish to say that any questions



RIVER, RAIL AND HILLSIDE VERDURE, PITTSBURGH & LAKE ERIE.

the simple engine, indicating, I am inclined to believe, a more thorough combustion of fuel in the compound boiler, due to the action of the exhaust steam on the fire of the compound being more evenly constant, and consequently conducive to a more thorough combustion than the intermittent or pulsating exhausts of the simple engine.

In this connection it may be observed that the compound engine evaporated 6/10 lb. of water more per pound of fuel burned than the simple, this increased boiler efficiency probably being due, to a large extent, to the same cause that contributed to the low temperature of the escaping gases. The amount of water evaporated per pound of coal, while above the general average secured in common practice, yet the increase was not as great as some might expect from such carefully conducted tests, especially

that I may ask, or statements that I make should be understood as indicating my position favorable to a certain system of steam economy, rather than favorable to any particular device or method of application. In other words, I wish to be distinctly understood, as standing in favor of, and for, high economy of fuel in steam engineering, obtained by the principle of compounding, as against the comparatively extravagant and wasteful results secured from the use of simple or single expansion engines, no matter whether it be in stationary, marine or locomotive practice. I wish to further qualify this statement by saying that there are places, in either of these services and especially so in locomotive practice, where the local conditions govern or control the type or kind of engine that must necessarily be used regardless of the question of fuel econ-

omy, and in railway service, or operation, the question of fuel economy particularly for switching engines light, branch runs, local freight and other similar service must frequently be and very properly is subordinated to more important questions of operation.

The results of this test have prompted me to review some compound engine history which may be very fresh in the mind of many members of this club. I think, however, that it has considerable bearing on this question at this particular time.

I find that in February, 1894, Mr. Qureau read a paper before this club in reference to the relative efficiency of compound vs. simple engine. The C., B. & Q. Ry. was quoted as having two-cylinder compounds, which were 30 per cent. less efficient in passenger service, but 15 per cent. more efficient in freight service than a simple engine, and 29 per cent. better than an average of 40 engines in freight service, showing a range of efficiency of from 30 per cent. below to 29 above, a total range of 59 per cent.

Prof. Storm Bull was quoted on engine tests of Rhode Island engines (compound) in New England, showing a saving in fuel of 15 to 25 per cent.

Mexican Central Ry., 25 per cent. in coal, 12 to 23 per cent. in water. W. N. Y. & P. Vaulchain, 4 cylinders, 30 to 40 per cent. in coal, and 12 to 26 per cent. in water. Long Island Railroad, Vaulchain, 4 cylinder engines, 37 per cent. in coal, 17 per cent. in water. B. & O. R. R., May, 1900, 14 9/10 saving in coal. E. T. V. & G. Ry., October, 1890, 30 per cent. and up. C. & N. W. Ry., 77/10 per cent. on coal and 17 per cent. on water.

Following this paper, Mr. E. M. Herr read a paper before this club in March, 1899, at which time he gave a great deal of interesting detailed information, affording conclusive proof of the efficiency of the compound over the simple engine.

The data forming the principal basis of the paper was taken from the Northern Pacific Road, reports showing fuel economy for the compound engine of from 38 to 52 per cent. in freight service on slow speed, while in passenger service 14 6/10 per cent. The C. & O. Ry. was quoted as showing a saving in repairs of 9 8/10 per cent. and on fuel 20 9/10 per cent. with a corresponding saving in water consumed.

The St. Paul Railway was one of the pioneers in the Northwest with an undisputed reputation for the high standard of its road and equipment in general, and particularly its locomotives, having purchased and used only the highest type in efficiency of engine that the country could and had produced up to that time. At the March meeting of this club in 1899, however, the late Mr. J. N. Barr, who was at that time superin-

tendent of machinery of the St. Paul Road, took part in the discussion and gave strong endorsement to the compound locomotive, among other things saying: "Six years ago I was very much undecided about the advisability of using a compound engine, but I am now criticising myself for not acting sooner. We now have compound engines exactly the same in every other respect as the simple engine on the same division, doing the same work and under precisely the same conditions and showing a fuel economy of 17 per cent. and 14 per cent. in repairs. These figures are correct and can be depended upon. As to the details my assistant who is present can give you further information."

The figures quoted by Mr. Barr were not only endorsed by his assistant, but the additional information furnished that the compounds were also making 69/10 per cent. more mileage than the simple engines.

It is also a matter of record that 25 heavy compound engines on the St. Paul Road were showing a saving of 27 3/10 per cent. over simple engines.

Seventeen per cent. at that time and four and three-tenths per cent. now, a difference of 12 7/10 per cent., while no figures are given on repairs or mileage, both very important items. The question to me, and which I make bold to ask my friend Mr. De Voy. Has the St. Paul simple engine of to-day in its improved condition as compared to those in use six years ago, rivaled the compound in efficiency, or has the compound deteriorated, or were there any local conditions at the time of the former tests which might suggest that the figures given as the result at that time were open to criticism or subject to either revision or correction in any way that would serve to harmonize the wide range of difference of 17 per cent. at that time on fuel, 14 per cent. on repairs with 69/10 more mileage, while at the present time there seems to be only the slight margin of 43/10 per cent. in the item of fuel economy alone.

In this connection I beg also to review briefly the paper of Mr. F. J. Cole, before the New York Railroad Club, November, 1901, on compound engines, in which he reviews the progress of the compound engine very exhaustively, and which, is summed up giving a fair and conservative average fuel economy of 11 per cent., boiler efficiency 17 per cent., cylinder or steam distribution efficiency 6 per cent.

The American Railway Master Mechanics' Association has kept in close touch with this question for years. reports having been submitted at different times invariably endorsing the compound engine. In 1900 a committee made a very elaborate report, the sense of the convention being that the compound locomotive had at that time emerged from

and passed beyond the experimental stage, with an established efficiency over the simple engine of 10 to 15 per cent., economy in fuel, and with equal regularity as to making trips. In this report the data furnished from different lines included among others the following:

C. & O. compound engines making 18 per cent. more mileage than simple; cost of repairs 8 4/10 per cent. less, fuel 21 per cent. less and the cost of lubrication 30 per cent. less. Mr. A. E. Mitchell, the well-known motive power officer, questioned the figures on lubrication, stating that he believed this showed waste of oil on the simple engines rather than economy from the compound, which position was practically agreed to by C. & O. officials.

The St. Paul Road showed in this report a comparison of simple and compound engines for a period of 12 months, an efficiency of 15 to 25 per cent. in fuel, giving an average of 20 3/10 per cent.

The committee in its report to the convention, found that the compound would require 15 per cent. more for lubrication, but would show a saving of 16 5/10 per cent. in fuel on ton mile basis.

One of the most prominent railways in the western country has in recent years added to its motive power equipment a great many compound engines. In one large order for heavy compound engines one of them was equipped with simple cylinders, in order that the relative efficiency might be determined as between engines of precisely the same class. From a standpoint of fuel economy the simple engine made 14 5/10 miles per ton of coal while the compound made 18 5/10 over the same division, the same weight of train, showing an efficiency of 26 6/10 per cent. in favor of the compound, for a period of 6 months' actual service. The compound also handled easily 150 tons more on the level and 200 tons on the hills, due to the more constant and even turning moment exerted on the driving wheels.

Another and a more striking illustration of the high efficiency and superiority of the compound locomotive over the simple locomotive for the service to which this company has assigned them will be found in the following comparison or illustration of service tests in a mountainous country, and which fully endorses the wisdom of the action of that company's executive who has already invested millions in compound engines and is still buying more.

To secure a reliable basis of comparison there was one simple engine assigned in pool service among a number of compounds as in the above test, and accurate data of performance and cost kept for a period of six months, the tests being on grades of 78 to 95 ft. to the mile, consequently much drifting. The

(Continued on page 291.)



The formula given above is not used in mathematics, though it almost looks as if it might be. The letters and figures are intended to express a chemical reaction and when translated, they read: Calcium carbide plus water, gives acetylene and slacked lime. One of the



GOAT MOUNTAIN FROM BANFF—CANADIAN PACIFIC RAILWAY.

places where they cause this chemical transformation to take place for commercial purposes is at the Hoboken yards of the Lackawanna Railroad. Acetylene is used for lighting trains on the dustless road of anthracite, and it can also be used for a shop illuminant. The D., L. & W. have a neat little generating plant capable of supplying gas for about 750 to 1,000 cars a month, and the way that they do it is this:

In a neat little two-story building there are a couple of generators which are large circular tanks, filled with water, and from a hopper above containing what the man calls "carbide," the operator is able to drop what amounts to a good sized handful at a time. When the calcium carbide drops into the water, acetylene gas is given off, and it rises in large bubbles to the surface and is conveyed through suitable pipes to a gasometer capable of holding 5,000 cu. ft. Every few moments the operator drops carbide down out of the moistureproof hopper, until the "charge" is exhausted.

When the gasometer has received a sufficient quantity, the gas in it is conveyed through another pipe line to a series of vertical cylinders called dryers. These cylinders are arranged so that the gas enters the bottom of one and passes to the top and is then conveyed to the bottom of the next, and so on. These cylinders are simply filled with carbide, which has a great affinity for water, and as the gas passes up through the lumps it parts with its moisture, and by the time it leaves the last dryer it is dry. It next goes through what you and I and ordinary people would call a purifier, but a gas man calls the flat oblong tank, a scrubber. There is no mechanical action in thus "scrubbing" the gas, the apparatus contains a prepared substance which takes up the sulphur and ammonia and does not apparently lose its ability to

carry on the process for a very long time. In the making of this gas there is, as we have already intimated, a quantity of slacked lime formed at the bottom of the generator. In railway economics this by-product can be used for whitewashing the walls of roundhouses and shops, so that there is absolutely no refuse to get rid of.

When the gas is clean and dry, so to speak, a three-stage compressor makes it take up less room but brings its pressure up to about 150 lbs. to the square inch. The gas in this state is ready for use as an illuminant. It is not only inflammable, but under pressure is a powerful explosive, and it is at this point that the Safety Storage System used by the Commercial Acetylene Company of New York, comes in and renders this gas as just described perfectly safe and very economical. The compressed gas is forced into long cylindrical storage tanks, which have previously been packed full of asbestos. If you could see the inside of one of these tanks you would think nothing else could get it, but the asbestos has 80 per cent. porosity, and, moreover, it has been saturated with a



"WRECKFUL SCENES THAT CLOUD THE BROW OF WAR."

liquid called acetone. Those two substances would seem to take up all the available space, but the acetylene can still go in and pack itself away so completely that sardines in a box have "waltzing room" by comparison.

The liquid acetone is made by the destructive distillation of woody fiber and is first cousin to wood alcohol. This liquid has the peculiar property of being able to dissolve about 23 times its own volume of acetylene at a temperature of 62 degrees F. The porous asbestos is simply used to fully distribute the liquid acetone all through the storage tank. When the acetylene gas, at 150 lbs. pressure, has all been dissolved, the resulting liquid is non-explosive. Thus the double function of taking up an inflammable gas under heavy pressure and rendering it perfectly safe to carry about has been accomplished by the presence in the tank of the liquid acetone.

When used as a railway car illuminant it is stored in tanks under the car floor, similar to the storage tanks of any other

storage gas system, and holding gas enough to light a car four hours per night for about two months. Gas is drawn off as used, and in passing from the storage tank to the pipe system of the car, it goes through an automatic regulating valve, similar in function to the reducing valve of the Westinghouse air signal system. This regulating valve reduces the gas from storage pressure to the few ounces necessary to drive it through the burners in the car. There is also a relief device provided on the car pipe system, so that in case the regulating valve got so far out of order as to permit a pressure of 5 lbs. to accumulate in the pipes, the relief valve would vent the gas to the atmosphere outside the car.

The light given by acetylene gas resembles sunlight in quality more nearly than that of any other artificial illuminant, in its color values stand to one another as they would in daylight, and when properly diffused it is easy and pleasant to read by. The size of the tank under the car is 20 ins. in diameter by 114 ins. long. It weighs about 1,650 lbs., and holds 2,000 cu. ft. of gas. When acetylene gas is burned in the cars it comes from the tank unaffected by its having been dissolved in acetone, and only an exceedingly small quantity of the vapor of the liquid passes over, and is burned with the gas, so that fresh acetone has only to be supplied to the storage tanks at very long intervals. Acetylene being what chemists would call a perfect gas, it is practically not affected by temperature and burns as well in cold weather as it does in the summer days. As a matter of fact, it only loses 1/273 of its volume with each decrease of one degree Centigrade. What is called the candle power of the light is high, and an idea of what that means may be had by the statement that when acetylene is compared with ordinary city gas, such as is used in our houses, the latter gives between three and four candle power per



THE VALLEY OF THE BOW RIVER AT BANFF—CANADIAN PACIFIC RY.

cubic foot, while acetylene gives 50 candle power for each cubic foot burned. In other words, acetylene is more than 12 times as bright. Gas piping and ordinary gas fixtures are suitable for acety-

lene with the sole exception of the burners which are made specially for this gas, which is so rich in illuminating power that it can make a street lamp gas flame cast a shadow on a white wall.

#### Oil vs. Electric Headlights.

The relative merits of oil and electric headlights were discussed by Mr. S. A. Abbott, division foreman, at Newburg, Mo., on the St. Louis & San Francisco Railroad, in a paper read by him at the International General Foremen's Association, which recently met at St. Louis. Mr. Abbott said:

In the discussion of this important subject, "What advantages the electric headlight has over the oil lamp, consid-

that they are as reliable as the oil lamp, and, in my experience, more so, for this reason: If a globe breaks or the glass in goggle breaks, with the oil headlight, it puts you out of business, and, again, if the one who is filling the oil reservoir gets same too full of oil, there is great danger of the oil igniting and burning the headlight up, reservoir exploding, etc. With the electric headlight, there is no explosion of oil reservoirs, because there is none containing oil of such character as will explode, and if the glass breaks, the light continues to burn, the only effect the broken glass has upon the light being to cause the carbon to burn a little faster, which is nothing serious compared with the same conditions

per hour—it being simply a case of the blind leading the blind and trusting everything will be favorable. When the electric light is used, no matter how poor the conditions of everything pertaining, you will always get a 100 per cent. better light than with the oil light, and when the electric light is given a little attention, such as daily cleaning of the commutator, oiling of the two bearings and keeping the reflector clean and the lamp focused, the engineer can always see far enough ahead of him, no matter how fast his speed may be, to observe any irregularity in the track in good and sufficient time to bring the train to rest and avoid an accident. This point alone should be sufficient argument to con-



THE "PALM LIMITED" ON THE SOUTHERN RAILWAY.

ering the expense of maintaining it, and the effect upon the eyes of the engineer," there are many things that can be claimed for the electric light, and much may be said showing its merits, in various ways, as compared with the ordinary oil lamp, but we shall consider only a few points concerning the same, which are as follows:

We shall first consider the reliability of the electric light as compared with the oil lamp, this being in my judgment the most important feature of a headlight; reliability, as a light that cannot be relied upon is not the light for engineers to risk their lives and the company's property with. In discussion of this point, I have no hesitancy in stating

existing on the oil lamp; hence, we can claim this point for the electric headlight.

We shall next consider the superiority of the electric headlight, as compared with the oil lamp, having established the reliability of the electric light. In consideration of this point, I shall endeavor to show you wherein the electric light is more serviceable than the oil lamp: With the oil lamp it is very difficult to see a switch point when the engine is moving slowly, particularly so with the modern high-speed locomotive, and it is absolutely impossible for the engineer to see an object upon the track with an oil light when running at the popular speed of the day—sixty miles

vince any sane man of the superiority of the electric light, as far as the qualities of the two are concerned; but, in addition to this, I will say that the electric light reduces the stock claims and accidents of similar kinds, in proof of which I shall deem it unnecessary to offer any official statements, but simply leave the same with your own personal knowledge.

The third point in discussion of this subject is the expense of maintaining the headlight, which, after once having engines equipped with the electric lights, is much cheaper than the oil light. As regards the repair work to be done on the electric headlight equipment (the Pyle National is the light referred to),

there are only four parts that can wear out—the two bearings, the commutator and the governor plungers. The shafts are made of the best steel and the bearings are of the best of bronze, and if lubricated, the wear of bearings will all take place in the boxes. The cost of renewals is very small, the main bearings will cost \$3, and the small ones in the engine cap \$1.50, wage of workman added. Any good machinist can replace either bearing in an hour and one-half. Both of these bearings will run without renewals from one to two years, with only reasonable care, and if given the same attention as the air pump in the way of lubrication, will last from two to three years.

I am inclined to think that too little attention has been given the governor of the electric headlight—perhaps for the reason that it was not understood. The cost of renewal of governor plungers is \$1 plus the wage of the workman. In conclusion of this point, allow me to say that the electric headlight should be given the same inspection as the air pump to have a never failing headlight. The greatest trouble with the electric light is caused by the wires not being protected properly, the insulation chaffing off, exposing the wires to contact with each other, either directly or through the medium of a bolt, handrailing, headlight case, etc.

I have reliable information to the effect that the average cost of maintenance of the electric headlight on larger systems for the months of October, November and December, 1905, was 85c. per month on each equipment. This does not include cost of carbons, oil or wages of inspector, and I think you can safely figure that the total cost of operation and maintenance of the electric headlight will not exceed \$2.50 per month. You are aware that such figure for the operation and oil for an oil headlight is not a maximum, and oftentimes it will run far above that when you add the trimmer's wages for his part of the work, the broken glasses, etc.

Lastly, let us consider for a moment the so-called injurious effect of the electric light on the engineer's eyes. You are aware that all such talk is a farce, and we shall give only a short argument on this point: As we have already said, with the electric light, the engineer is enabled to see from one-fourth to three-fourths of a mile ahead of his engine, the track being straight, no matter what the rate of speed may be. This enables the engineer to see far enough ahead to know how to handle the brakes, same as in daylight, and in approaching stations, instead of going along slowly, and, as it were, feeling his way, he can go right along and not slow down unless they expect to stop. This being a fact, the engineer is not straining his eyes

to see a few feet ahead of his pilot. Another point worthy of consideration, is the fact that when the fireman has put in a fire and gets up to his side of the cab, he can see immediately out the window as far ahead as the engineer. The reason is that the temperature of the arc is about 5,000 degrees higher than the temperature of the fire box, and so the shaft of light the electric light throws off is much brighter than the fire in the fire box. This I consider one especially

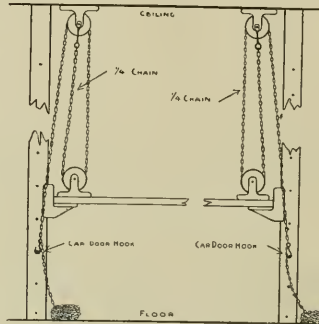

ARRANGEMENT OF SCAFFOLDING.

strong point that can be claimed for the electric light.

It is also claimed by engineers that break-in-tuos on long, heavy freight trains are almost entirely eliminated when the engine is equipped with electric light, claiming that such accidents usually occur at night, because the brakes have been improperly handled, releasing when the train was moving at a very low rate of speed. When the engine is

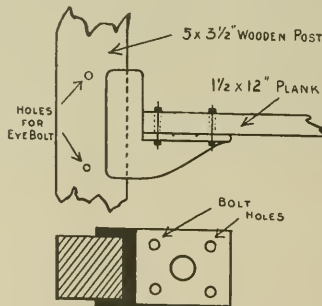

SLIDE AND BRACKET FOR SCAFFOLDING.

equipped with the electric light, the engineer can see practically as good as in daylight, and would, therefore, handle his brakes the same. This is one of the strongest points that can be produced in favor of the electric light, and it being applied to engines in freight service. When the electric light is used on double track, engineers claim that it does not interfere with their vision in the least. Of course, we all have more or less a side vision, and when meeting an en-

gine equipped with an electric light, all you have to do is to pull your cap down over your forehead a little and look out under the brim, or lean back in the cab and let the side of the cab shade the eyes, and the engineers find they can see the pilot of the approaching engine.

The last point in connection with the effect of the electric light on the engineer's eyes which we shall mention, is that the electric light has a tendency to keep the engineer awake. You are all well aware that it is almost impossible to get an engineer to double back in the night time, when using an oil lamp for a headlight, but they will nearly always double back in the day time. With the electric headlight, the engineer will not hesitate to double back at night, as the great shaft of light thrown ahead of the engine by the electric headlight, constantly changing his view, tends to stimulate the nerve and pulls the man up like watching horses running a race.

Summed up in a few words, it can be justly claimed for the electric headlight that it provides for better light, making it possible to attain higher speed at all times, with more safety, causing fewer wrecks, less danger to lives of employes and less damage to property of company, as well as contents of train; makes running more convenient to the engineer, and is facilitating to all concerned, and, in fact, has advantages over the oil headlight in reliability, expense of light and the effect it has upon the engineer's eyes is very gratifying to the engineer.

#### Paint Shop Scaffolding.

There is a style of paint shop scaffolding used in the Brightwood shops of the Big Four at Indianapolis, which is easily made and is a very satisfactory appliance. It is so arranged that a workman can quickly adjust it to any height he desires and when it is properly fixed it stays fixed, until the time comes for again raising or lowering it. Mr. F. M. Lawler is the master mechanic of the large repair plant at that point, and the scaffolding used in his shop, though home-made, is an ingenious piece of shop furniture.

There are a series of wooden posts placed about 18 ft. apart beside the paint shop tracks and these run from floor to ceiling. There is in each post a series of holes about a foot apart, bored clear through and suitable for receiving a  $\frac{3}{4}$  in. eye bolt which can be put in by hand. The scaffolding plank is 12 ins. wide by  $1\frac{1}{2}$  ins. thick, and each end is bolted to a cast iron bracket which forms a guide which slides on one face of a post.

There are four pulleys used on the scaffolding in one bay or panel in the shop. Two are attached to the ceiling and two to the movable plank, and a  $\frac{1}{4}$  in. chain is rove through the pulleys

so that the fall comes down from the upper one. At a convenient point on each of the chains is securely fastened an ordinary car door hook. This hook, as we may say, when speaking of one end of the scaffolding, is slipped through the eye of one of the bolts which has previously been pushed into one of the holes in the side of the post, and when both sides have been adjusted the scaffolding is ready for use.

The alteration of the height of the eyebolt determines the position of the plank upon which the workman stands. The pulleys form an easy and rapid method of raising or lowering the scaffold and the car door hook through the eyebolt holds everything in position. There is enough chain below the hook to reach the ground at all times, no matter whether the plank is high or low, so that the chain is never out of reach. A modification of the arrangement would be to have the eyebolt and the hook attached to each other, in which case the hook could be put through

add saving of cost to speed of action is well worthy of attention. This, the King-Lawson dump car does, and it may be considered as an exponent of modern methods as applied to the constant handling of heavy loads of earth and rock.

The desirability of speedily discharging cars cannot be overestimated, as it enables their more frequent use at times when it would be impossible on many railroads to resort to the ordinary method of unloading. The absence of complicated mechanism, liable to get out of order, at inopportune times, places these cars at once on a high plane of excellence.

Ten such cars have been at work during the last season on the Lackawanna, at Kingsland, N. J., handling rock excavation, and they have stood the test of hard usage and demonstrated their ability to carry on the work both as regards economy and durability. Sometimes pieces of rock weighing one and a half or two tons have been loaded in

door opening when discharging load, 3 ft. 4 ins.

There is a method of getting even a larger side door opening when it becomes necessary to do so. The ordinary opening is 40 ins., but 42 ins. in the clear may be had by placing a suitable wedge on the incline down which the roller runs which raises the car side from the tilted floor. The action of the King-Lawson car is briefly that the floor tilts to an angle of 35 degrees from the horizontal and the side of the car moves so as to leave a normal opening 40 ins. high by 28 ft. long; in fact, its action is analogous to an animal opening its jaws and the jar caused by the stoppage of the lower jaw when mouth is wide open insures that the load shall make a move, and even sticky clay goes out in bulk as well as a frozen mass of coal.

#### Walschaerts Valve Gear.

The Baldwin Locomotive Works of Philadelphia, Pa., have issued a pamphlet

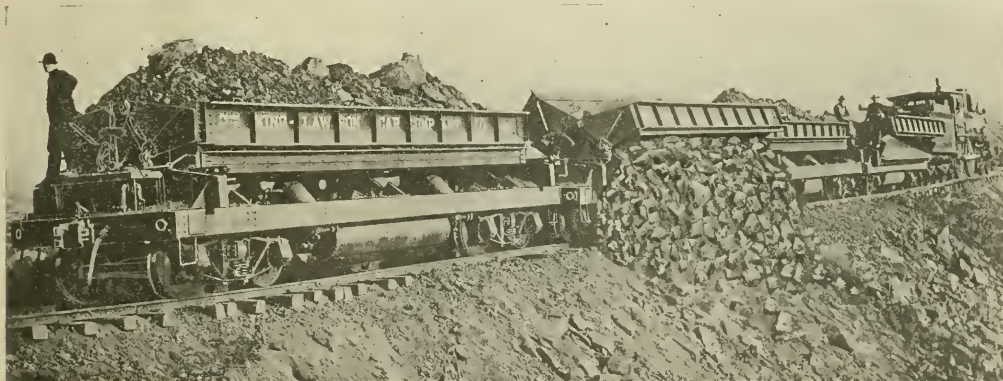

"CAUGHT WITH THE GOODS." INSTANTANEOUS PHOTOGRAPH OF THE KING-LAWSON CAR IN ACTION.

a link in the chain anywhere, and so hold the plank at the required height.

#### Side Dump Car.

The King-Lawson Steel Dump Car, a view of which we show in operation, is a standard gauge car equipped with all the M. C. B. requirements. It is made with a movable body, carried on practically frictionless wheels and operated by air pressure, taken direct from the train line. These cars are built to carry 80,000 lbs. of earth, stone gravel, rock and other like material, and the load can be discharged at either side of track in less than ten seconds, and the angle at which it goes out is such that it is thrown well clear of the track.

Its special adaptation for construction work renders this style of side dump car most useful in these days of gigantic operations, for any appliance that will

these cars, and handled as easily as small stones could have been, and without causing damage to the cars.

The car is a one-body box, dumping on either side of the track at the will of the operator. Some of the principal dimensions are as follows: Contents of box level full, 392 cu. ft.; contents of box with 30 degree heap, 618 cu. ft.; nominal capacity, 80,000 lbs.; approximate weight, 50,000 lbs.; length over end sills, 34 ft.; length inside of box, 28 ft.; center to center of trucks, 24 ft.; truck wheel base, 5 ft. 6 ins.; width over side sills, 8 ft. 6 ins.; width over all, 10 ft.; inside width of box, 7 ft.; inside height of box, 2 ft.; height from rail to top of side sill, 3 ft. 6<sup>3</sup>/<sub>8</sub> ins.; height from rail to door, 7 ft. 7 in. 9<sup>3</sup>/<sub>8</sub> ins.; height over all, 8 ft. 2<sup>3</sup>/<sub>8</sub> ins.; height from rail to center of draw-bar, 2 ft. 10 1/2 ins.;

which is one of the series they call record of recent construction No. 55. This pamphlet which is similar to other publications by the well-known firm, is devoted to the consideration of Walschaerts valve gear. It opens with a general description of this form of valve motion and the letterpress is illustrated by half-tones showing how the gear has been applied to a Pennsylvania consolidation engine, a rack locomotive for the Manitou & Pike's Peak railway, a combination rack and adhesion locomotive for the San Domingo Government and a curious looking 4-wheel rack-rail climber for the Leopoldina railway. These types show the very different kinds of machines to which Walschaerts gear has been successfully applied. The second chapter, if we may so say, is devoted to the giving of general instructions and there is a line drawing illustrating the

functions of the various parts. Special instructions follow for the use of those who have to do with erecting the motion and setting valves. The last portion of the pamphlet is taken up with illustrations and descriptive specifications of engines which have been built for home and foreign railways upon which Walschaerts motion has been used. There are eight such engines given and the pamphlet concludes with an historical sketch of the origin and development of the gear. Those who desire to obtain a copy of the pamphlet—and as no one who is concerned in valve setting or valve work of any kind can afford to do without it—should write direct to the Baldwin Works for a copy.

#### Machine Tools.

The latter half of Mr. L. R. Laizure's paper on Machine Shop Practice is as follows. In this he deals with the work and the possibilities of machine tools in a railroad repair shop. The first part of the paper is given elsewhere. He continued his address by saying:

The chief function of a machine tool is not, in the majority of cases, to remove the greatest possible weight of metal in a given length of time. It is much cheaper to have castings and forgings come somewhere near the finished size, than to depend upon the lathe and planer to do it all. The foreman of the shop would be surprised if he would make a test to find out how small a percentage of time was required for the actual cutting and how large a percentage for setting up and changing the work. It is, therefore, not only necessary to study out how quickly the piece of work can be machined, but also it is essential to study the quickest method of chucking and setting-up, and then to see that the proper speeds and feeds are used to get the maximum results.

Some of the machines which have done much to revolutionize the machine shop world are the Pond Truck Tire Lathe, the Niles 90 in. Driving Wheel and Chucking Lathe, the Double Head Axle Lathe, the 90 in. Vertical Boring and Turning Mill, the Lodge & Shipley Crank Pin Lathe, the Landis Grinding Machine, and many others.

The antiquated lathe for turning steel-tired truck wheels, which was in use some ten years ago, would turn out with the use of water hardened steel, from two to three pairs of wheels per day of ten hours. The modern lathe, with the use of high speed steel, has a capacity of from seven to ten pairs per day of ten hours. The usual speed is from seven to thirteen feet per minute, or whatever the tool will stand. This is a motor driven machine, and with a  $\frac{3}{8}$  in. feed gives very satisfactory results. The scraper tool for finishing the tread in two revolutions, and the forming or flanging tool

have much to do with the output of this machine.

Next we have the 90 in. driving wheel and chucking lathe. This is a machine for turning driving wheel tires, and has a capacity of from seven to ten pairs per day, or about four times the number that could be turned out by such a machine ten years ago. To sum it up, one man with a modern lathe, is capable of doing the work of four or five skilled mechanics of ten years ago and working under old conditions.

The double head axle lathe is another machine that has proved its worth in the up-to-date machine shop. It has been but a few years since it took ten to twelve hours to turn and finish a main driving axle from the rough. This same job is now performed on the modern machine in about four hours, or a saving of over one-half.

The 90 in. vertical boring and turning mill, with its motor drive, has also been making some records, the most prominent of which is its driving wheel tire operations. Ten years ago three tires a day was considered the country's record—this with the water hardening steel. The writer knows of a case four years ago where a mechanic would not accept a price of \$1 per tire for boring, but today, with the modern machine and high speed steel, they are bored at the rate of 30 minutes a piece and better, thus averaging 20 tires per day of ten hours, sizes not considered.

We have also the 37 in., 42 in. and 51 in. boring mills, which are very efficient for the work done on this class of machine. Considerable work is now done on the boring mill which was formerly done on the lathe, and at a great saving in time and cost. Eccentric straps, for instance, which were formerly done on the lathe at a rate of two or three per day of ten hours, are now done on the boring mills at the rate of one per hour. Another instance is the operation for turning cylinder packing. This was formerly done on the lathe and is still in practice in some shops. In this shop, however, it is done on the vertical boring mill at the rate of five or six per hour. The vertical milling machine is one of the most valuable of the modern shop tools for miscellaneous work.

The Lodge & Shipley crank pin lathe, with its 15 h.p. motor, is also a modern and indispensable tool. This machine has a 24 in. throw, and has a capacity of from eight to ten main crank pins per day of 10 hours. One roughing cut and one finishing cut are all that is necessary to complete a pin ready for fitting. The average capacity of the old machine for doing this work was from two to four pins per day.

The Lodge & Shipley Piston Lathe, with its 8 in. belt, single step cone and variable speed countershaft, has also

contributed its share in making machine shop records. This machine will take a piston rod 57 ins. long and 4 ins. in diameter, center it, rough turn it, and thread it complete in 30 or 40 minutes. The rod, after being rough turned, is taken to the Landis grinding machine, and is ground to finish size in from 15 to 20 minutes, thus giving this machine a capacity of from eight to ten rods per day. This work on the old machine consumed from three to four and one-half hours per rod. Piston rods and valve stems are also trued up on the Landis grinder in about one-third the time that it used to take to perform the operation on an ordinary lathe.

Some of the other machines that have contributed their share towards advancing machine shop practice and methods are the engine lathes, with their patent speed boxes for instantaneous changes of feeds and speeds, Turret lathes, vertical milling machines and bolt threading machines. A few years ago a bolt threading machine had a capacity of 800 bolts per day, and to-day machines have a capacity of from 2,000 to 2,500 per day of ten hours.

Most railroad shops have paid but little attention to improved facilities and machinery, and have considered it economy to use tools fifteen or twenty years behind the times, not always realizing that a modern machine will do from two to five times the work of the old one.

Returning again to the subject of general machine shop practice, some radical changes have taken place, which have not been mentioned heretofore, and are very worthy of note. Among these is the substitution of the motor-driven sectional line shafting. The special advantage of this arrangement is that in case of a breakdown it is not necessary to close down the entire shop; also in cases where it is necessary to work after regular hours, it is not necessary to run the whole line shaft, thus saving wear and tear, which would result from running the whole shaft.

Another feature of an up-to-date shop is the power house in which the electricity, live steam, compressed air, and exhaust steam are generated to be transmitted to the shop to perform their various duties, namely, the electricity to furnish the power to run the line shafts, individually driven machines, cranes, and also for lighting purposes; the live steam to run the blacksmith shop and also to be used for the roundhouse blowers; compressed air to be used in connection with the pneumatic tools and for other purposes, and the exhaust steam to furnish heat for the shop.

The systematic grouping of the machines and work also has done much to reduce the cost of repairs and increase the output of the shop. After the work of stripping an engine is completed, the



various parts should be moved as little as possible about the shop. For instance, all work pertaining to crossheads should be performed in one department. This is also true of side rod work, driving box work, and driving wheel work, etc.

Equally important in its line is the specialization of individual labor and the piece work system. These subjects are doing more to increase the output of the shops with decreased cost than anything else that has been brought about in late years, with the possible exception of modern machines and high speed steels. The specialist is the man of the future. The man who can take a certain piece of work and do it quickly and well, and in the shortest time, is the one who is in great demand. Men who claim to be capable of doing almost anything in mechanics are rapidly giving way to those who can do a few things quickly and well.

Specialization of work by gangs is also coming to be recognized as the proper method of doing the work in the erecting department. So far as possible, certain work should be assigned to certain gangs, each gang to follow up that class of work on all engines in the shop. By this organization you not only save time and money, but each man does not have to be supplied with a kit of tools for performing every operation on the locomotive.

Along with the specialization of labor goes the piece work system. This system benefits both the workman and the company, because the ability of the former is taken into consideration; also time and conditions, and the company is benefitted because the work is turned out more rapidly and accurately when the workman is working for himself, as it were.

When we sum up all these conditions, four things are specially prominent in a well organized shop, namely: the high efficiency of modern machinery and tools, high speed steels, specialization of labor, and the system of piece work. Any shop combining these four characteristics has a quartet that cannot be beaten in modern shop practice.

#### Jarred the Target.

During the discussion at the last meeting of the New York Railroad Club, Mr. E. T. James' paper on Care and Maintenance of Locomotives evoked a variety of comments, and the paltry salaries usually paid to roundhouse foremen was alluded to by several speakers. Mr. Paul R. Brooks, of the Quincy, Manchester, Sargent Co., having at one time been a roundhouse foreman, spoke from actual experience when he said:

"Mr. President: With your permission I would like to take a shot at the bull's-eye of the roundhouse situation.

The consensus of opinion to-night seems to be that an ideal roundhouse foreman is born and not made. It therefore appears to be necessary to find some means of influencing the birth-rate. Without entering into the discussion of whether either of the following men were predestined for this position or not, let me tell a little tale. Once upon a time, out West, a young man left a large roundhouse to enter the much-abused supply business. The only man who could afford to take that roundhouse position was an extra engineman off, from a construction train. None of the good men on the division could afford to take the place."

There is a very important series of questions and answers in our Correspondence School columns this month, dealing with the injector, and this has made the perusal of the railway edition of the illustrated and descriptive catalogue of the Nathan Manufacturing Company a very interesting and timely

pany, dealing with the Simplex injector, type R; the "Nathan" triple sight feed locomotive lubricator, pattern No. 147; the new "Bull's-eye" lubricator, the coal muffler and safety, and the Reflex water gauge. This is the flat grooved glass style, made under the Klinger patent, which shows in the steam space a silvery luster and the water column black. Write direct to the Nathan people for any of these folders or the catalogue, if you require one or all.

#### King Edward's Train.

It is said that perhaps the most perfectly appointed train ever made is the one used by King Edward VII when he travels. It is, of course, a series of private cars, each of which is as fine a specimen as the car builders of the United Kingdom ever constructed. The most striking thing, at least to our eyes, is the unique simplicity of the whole train as far as decoration is concerned.

The sleeping car is finished in light

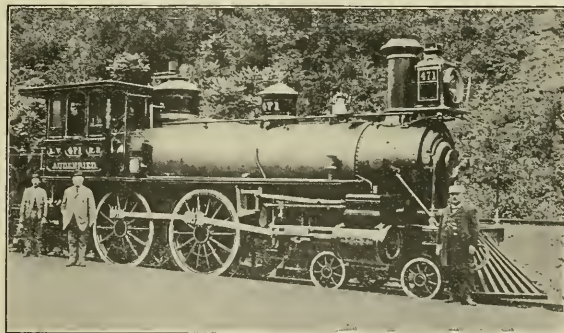

LEHIGH VALLEY ENGINE WITH CLARK'S INDEPENDENT CUT OFF.

proceeding. All the styles of injectors and the parts made by this company are described and shown in plain, clear line engravings, which are numbered for ordering. Among the injectors is the Monitor, the "88" Monitor, the "88" P. R. R. standard monitor, the P. R. R. standard monitor, the Class W-F non-lifting injector, the new "Nathan" injector, class A, non-lifting injector, and the Class B lifting injector. In addition, there are the parts separately, ejectors, tank strainers, fire extinguishers, boiler washers and fillers, sanding apparatus and relief valves. The catalogue also includes sight feed lubricators, oil cups, gauge cocks and parts of each. This publication is useful in going over our injector questions and answers, and can be had on application to the company, whose New York address is 92 and 94 Liberty street. Several folders have also been issued by the Nathan Manufacturing Com-

shades of blue and pure white. The compartments are necessarily small, yet the artistic effect produced is to give one the idea of spaciousness. The windows are large, compared with railway car sizes, and the coaches are consequently bright and airy. There is, of course, a very complete bathroom compartment in the sleeping car, and there are ample clothes closets, hooks, presses and lockers. In the same car in which the King sleeps there are compartments for the accommodation of servants. Other cars in the train are used for dining and day occupations.

Great care is taken when this train is run over any of the lines of the English or Scottish roads, a pilot engine always precedes the royal train, and the King's special is given right of way over other trains. There is no unnecessary fuss about the matter, but nothing is left undone which will insure the safety or prompt handling of the train when the King travels.

### Officers Elected.

The following officers were elected for the year 1906-7 at the recent meeting of the International General Foremen's Association: Mr. C. A. Swan, Jr., president of the association; first vice-president, Mr. Elton F. Fay, U. P., Cheyenne, Wyo.; second vice-president, Mr. Lee R. Laizure, Erie R. R., Hornellsville, N. Y.; third vice-president, Mr. William E. Farrell, Big Four, Delaware, O.; fourth vice-president, Mr. J. J. Houlihan, Wabash, Ft. Wayne, Ind.; secretary, Mr. E. C. Cook, St. Louis, Mo.; treasurer, Mr. H. F. Martyr, Frisco R. R., Cape Girardeau, Mo.; executive committee—Messrs. S. A. Moore, C. R. I. & P. R. R., Chickasaw, I. T., and J. C. Wilkinson, Rock Island, Shawnee, O. T. Chicago was chosen as the next meeting place.

### Dustless Road Record.

The Lackawanna Railroad people have issued for their own benefit a very interesting report which shows that 53,784 engines were dispatched from their Scranton roundhouse during the year ending April 1, 1906. An accurate account has been kept day and night of the time of departure of each engine to insure its prompt delivery at the time appointed by the transportation department, and if failure to deliver on time occurred, then the exact detention time and the cause of delay were made note of. This report shows that only 607 late deliveries were made and 35 per cent. of these resulted from causes over which the roundhouse force had no control, such as brakeman late, engines blocked in congested yard, etc. The average detention met with by each engine in its delivery is shown to be but 20 seconds.

Only 175 engines were engaged at any time during the year and over one-half of the business was handled during the winter months when the coal traffic was heavy. When it is considered that the coal chute is located a quarter of a mile distant from the roundhouse and all engines had to be moved to it through a crowded yard, and in addition to this over one-third of the repairs to engines were made in the open air, this being always the case on the heavy consolidation engines, this record may be looked on as exceedingly good. The pace has been set by the Lackawanna in this matter and the result shows that eternal vigilance is the price of a "record." The work has been done under the supervision of Mr. H. Shoemaker, master mechanic, and the details have been worked out by his energetic subordinates, Robert Morton, general roundhouse foreman, and M. A. Quinn, chief engine dispatcher.

The tabulated statement which gives

the details of this and last year's work side by side, is interesting and instructive and shows a decrease in the number and duration of delays in delivery of engines, which is very creditable. The fact that 134 engines were blocked in the yard this year as against only 5 last year certainly "puts it up to" the transportation department to provide better facilities or more expeditious methods of taking hold of the engines delivered to them. In justice to that department, however, it should be said that under the item of "engines arriving late" they did better this year by a matter of 73 engines than they did the year before.

The report, however, has its sad side as well, for in it we see that two engineers this year, more than last, were late, bringing the total up to eleven, which makes an average of  $\frac{1}{11}$  of an engineer late each month. We also see that a total of 54 minutes was consumed by the slow movement of three engineers. These things are happily offset in some degree by the fact that the firemen reduced the number of their late arrivals by four, and the time lost in getting tools entirely disappeared this year.

A perusal of the tabulated figures which follow will prove interesting and instructive to all those having the care of, or being concerned in, the prompt handling of engines at terminals.

#### COMPARATIVE SUMMARY.

Items.	Year Ending	
	Apr. 1, 1905.	Apr. 1, 1906
No. of engines dispatched.	50,723	53,784
No. of engines delayed....	722	607
Engines dispatched to one delayed .....	70	89
Number of hours' delay..	504 h 2 m	305 h 43 m
Average length of delays.	42 m	30 m
Average detention per eng.	36 s	20 s
Cause of Delay. No.	Year Ending	
	Apr. 1, 1905.	Apr. 1, 1906.
Repairs .....	213 132 h 53 m	185 98 h 51 m
Engines arriving late.....	299 258 h 26 m	126 74 h 64 m
Enginemmen late	9 6 h	11 5 h 10 m
Brakemen late.	60 34 h 54 m	72 48 h 11 m
Firing engines.	23 20 h 13 m	7 6 h 23 m
Firemen late...	11 4 h 13 m	7 2 h 36 m
Cleaning fires..	4 1 h 20 m	9 3 h 47 m
Blocked in yard	5 2 h 5 m	134 45 h 47 m
Blocked at chute	42 51 h 51 m	18 5 h 6 m
Coaling engines	37 18 h 17 m	9 4 h 5 m
Water supply..	4 1 h 25 m	3 45 m
Ordered late...	1 35 m	0 0 0
Turntable out of order.....	7 5 h 33 m	8 2 h 28 m
Engs. derailed.	3 1 h 8 m	10 4 h 7 m
Getting tools...	4 1 h 10 m	
Engineer slow movement ...		3 54 m
Coal and water		1 16 m
	722 504 h 2 m	607 305 h 43 m

### Hammer Marks on Wood.

Occasionally one has reason to wish that a stray hammer mark could be removed from the surface of wood. A writer in the Blacksmith and Wheelwright gives the following as a good way to do it. He says:

"To raise hammer marks in soft

woods—such as pine—soak a little sawdust in water and apply to the dent and let it stand over night, but if in a hurry and cannot wait that length of time, just fill the dent with wood alcohol, let it stand for a minute to soak and then light a match and apply it to the alcohol. Watch very carefully so that the wood does not burn. In case it does, blow out the flame, then wait a minute or so, then fill the dent again with alcohol and repeat the process as at first until the dent is raised to the surface of the wood. This plan will do the same work on oak."

### Shandy Seeks Distinguished Headman.

Shandy Maguire, who is roundhouse foreman at Oswego, N. Y., for the Lackawanna, doesn't take kindly to being slugged by clerks who have the privilege of signing their superiors' names to letters pertaining to the service. Some time ago he received one from a supernumerary, which was not to his liking, and as he is the only hold-over from the old management of the road to the new, he supposed from the tone of the letter he was going to be Oslerized, but he had a decided objection to the job being done by a tyro, and he got on the train, Scranton bound, to get a more distinguished executioner than the one whose writing ability was so developed. After a very warm greeting from Mr. Harvey Shoemaker, his M. M., he stated that he sought the interview with the object of getting on the pension roll of the system.

"Upon what grounds?" said Mr. S.

"Read this letter," said Shandy. "Read between the lines of such a letter."

"I am pleased to note you have a vulnerable spot in your epidermis. After your visit here is ended, in your own good time, go back, and remember, when you do not fill the requirements, you will be notified by me."

"That's entirely satisfactory. And now, seeing you are a thoroughbred, do me another favor, and remember you have the blood in you to keep you from being ridden to death, if you are a free horse."

"What is it?"

"Give me a lay-off for 10 days to go to Memphis to meet the boys and give them a roast at the opening exercises of the seventh biennial convention of the B. of L. E."

"I'll grant it; and send Road Foreman of Engines Cooper to take your place while you are gone."

"I am not noted for talking the Deity to death, and when I say 'God bless you' He'll grant it."

Mr. S. told Shandy that the boss was in his office (as Mr. R. F. Kilpatrick,

the superintendent of M., P. & E., is called) and will be pleased to see you. Out he walked with a parting shake from Shoemaker, which he told P. J. Langan, the G. A. I., gripped him tighter than the emergency. He then crossed the hall and entered the boss's office. After an exceedingly cordial greeting he was asked what brought him down. "Oh, I got a stiffener of a letter which I read left-handed, as Mr. S. in-

scene of your earthly labors, and on all future occasions, when you get a billet doux like this, the only alternative is to chew the rag."

The 'phone jingled, the boss responded, and Shandy took his departure for his home.

#### General Service Gondola Car.

The Frisco System are at present receiving 200 all-steel drop bottom gen-

eral service gondola cars, 100 for the Chicago & Eastern Illinois and 100 for the Kansas City, Fort Scott & Memphis. This car embodies a number of good ideas in design, and it might properly be termed a 99 per cent. flat bottom dump car in that, although the floor of the car is flat with the doors

of its load of 99,300 lbs. of run-of-mine coal. This is somewhat less than the capacity of the car level-full. The other gives an idea of the interior of the car after the load has been dumped out.

The feature which at once strikes an observer about this 100,000-lb. gondola, is the fact that the plates which form the bottom of the car are the doors, which open and close as occasion requires. In fact, one might almost say that the whole bottom drops out of this car when the load is being dumped. The car has 16 drop doors in all. The 8 which cover the trucks drop to a clear opening of 23 ins., while the 8 doors in the center of the car give a 26-in. clear opening. The center sills are pressed so as to resemble an inverted letter V, and they are riveted to a T-shape which has a 4-in. top, and these sills are reinforced with angles at their lower edges. The center ridge of the car is so made as to be only 4 ins. wide. The body transoms are built up of plates and angles which give a 7-in. space, while the cross bearers are of pressed steel shapes and present a 3-in. top surface.

The doors are operated by a so-called "Creeping Shaft" mechanism, which is carried in slats by the cross bearers and bolsters, and while the doors are closed by chains attached to these shafts, the shafts themselves are automatically moved over underneath the doors, and when fully closed the load

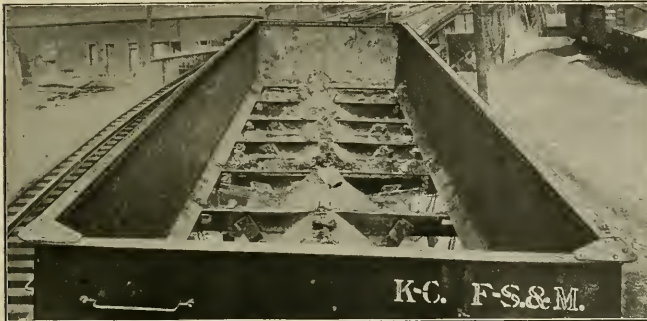

INTERIOR OF PRESSED STEEL GENERAL SERVICE GONDOLA.

formed me. I supposed the jig was up and I wanted a distinguished headman."

"Let me see it."

After reading, says the boss: "Do you know what I do when I get a letter like that?"

"Who dares write you in that style?"

"Shandy, as long as you are out from Ireland you are yet a regular Verdant Green in some things. I have to do my share of penance for the sins of omission and commission of you all. There is a higher power than I am, and he is a past grand master at making typewriters talk."

"That's news to me; and it exemplifies the quotation: 'Big fleas have little fleas upon their backs to bite them.'"

"I don't know about the fleas, but I do know about the letters, and I'll tell you how to act hereafter when you get one of them: First, read it; then put a good chew of tobacco into your mouth. After the juice begins to flow freely, read it again. If it continues to bite, roll the quid over to the other side of your mouth, and read it once more; by this time the soothing effect of the juice is acting on your nerves, and you can look upon its contents more philosophically and feel a heavenly resignation to all the ills of life. You can say with Burns in Tam O'Shanter:

'Kings may be blest, but Tam was glorious,

O'er a' the ills of life victorious.'

"That's all right for you to say, but I don't chew tobacco."

"Well, my dear friend, return to the

eral service gondola cars, 100 for the Chicago & Eastern Illinois and 100 for the Kansas City, Fort Scott & Memphis. This car embodies a number of good ideas in design, and it might properly be termed a 99 per cent. flat bottom dump car in that, although the floor of the car is flat with the doors



GENERAL SERVICE GONDOLA UNLOADING COAL.

closed and is to all appearances an ordinary flat bottom gondola car without hoppers, yet when the doors are opened it will discharge its load almost completely without any shoveling. The cars are of 100,000 lbs. capacity and were designed and built by the Pressed Steel Car Co., of Pittsburgh.

One of our illustrations shows a general view of the car while dumping half

is securely supported and accidental discharge becomes impossible.

The name selected for this type of car, that of general service gondola, indicates that it may be used to carry rough freight as an ordinary gondola does, or it can be used so as to hold and transport all kinds of material which may require to be dumped. On account of its flat, smooth bottom, free

of any depression, the load can be shoved out when dumping is not feasible. As a gondola, it can be used for the loading of lumber, pipe, bar iron, brick, sewer pipe or any materials which cannot conveniently be loaded in hopper cars.

A few of the general dimensions of the car are as follows: Length over end sills, 42 ft. 9 ins.; length inside of body, 41 ft. 9 ins.; width over stakes, 10 ft. 2 ins.; width inside, 9 ft. 6¾ ins.; depth of body to top of sides, 4 ft. 4 ins.; length of doors in clear, 4 ft. 10 ins.; width of doors in clear, 4 ft. 2½ ins.; height of floor from top of rail, 4 ft. 5 ins.; truck centers, 31 ft.

### Tests of Large Air Pumps

It being evident that the sentiment of those using air pumps is in the direction of larger air capacity, and to those skilled in the art, that larger capacity combined with steam economy can not be obtained with simple pumps, the Westinghouse Air Brake Company has recently produced a compound air pump of superior air capacity combined with a factor of steam economy far in excess of anything previously attempted.

The advent of this pump has created much interest and favorable comment on the part of railway officers, who upon investigation of its merits recognized its simplicity, greater capacity, and superb economical qualities. With a view of determining in a practical way the capabilities of this type of air compressor, a comparative test of the Westinghouse Compound and the New York No. 5 Duplex Pumps was recently made by the Lake Shore & Michigan Southern Railway Co. The schedule of tests was prepared and conducted by the engineering department of the road under the direction of the chief mechanical officers, and there was present during the demonstrations several prominent air brake experts of the road as well as representatives of the two air brake companies.

A very complete apparatus was employed for the tests, making entirely practical a comparison of air delivered, of steam consumed, of temperature of both free and compressed air, and of the general working of the pumps.

The tests were divided into three classes as follows:

1st. Efficiency and Capacity Tests, with pumps working against constant pressure;

2d. Efficiency and Capacity Tests, with the pumps working against increasing pressure, as in charging reservoirs;

3d. Efficiency and Capacity Tests, with the pumps working against an approximately constant pressure, an orifice in a diaphragm being used to ap-

proximate the amount of air delivered.

The results of these tests were in general as follows:

Pumping against a constant air pressure of 140 lbs. with a steam pressure of 200 lbs., the cross compound pumped 115.5 cu. ft. of free air per minute, while the New York No. 5 pumped only 75.2 cu. ft. per minute. To do this the cross compound used 21.5 lbs. of steam per 100 cu. ft. of free air while the New York No. 5 used 47.7 lbs. of steam per 100 cu. ft. free air, or more than double the amount used by the cross compound. In this test the volumetric efficiency of the Westinghouse cross compound was 82.1 per cent. against 62.2 for the New York No. 5.

Twenty tests of the above character were made with different boiler pressures against different air pressures, but the results were in each test highly favorable to the Westinghouse pump.

In the tests made working against increasing air pressure, the minimum air pressure at which the throttles were turned on wide open was 30 lbs. It was necessary to have this amount of pressure in the reservoir, on account of the excessive pounding of the New York pump; the cross compound, however, when started with throttle wide open, working against zero air pressure, and driven with 200 lbs. steam pressure did not pound, and thus it demonstrated the advantage of its design in this respect over both the simple and the duplex pumps. Twenty of these tests were made with different steam pressure pumping from 30 lbs. up to different maximum air pressures, and the results with respect to time required to accomplish the feat varied from 16 to 19 per cent. less, and for steam consumed from 51 to 93 per cent. less for the cross compound.

In the representative tests of the 3d class, pumping through the orifice, the air pressure pumped against was for the Westinghouse Compound initial 118 lbs. and final of 120; while for the New York it was 100 initial and 102 final, the duration of the tests being 2 minutes and the size of orifice used 17/64 in. The result of these tests showed that the cross compound used 25.6 lbs. of steam per minute while the New York used 40.6 lbs. and at the same time did not pump against so high an air pressure as did the cross compound.

The temperature records, taken at regular intervals during the test, showed the duplex air pump to acquire a temperature of about 100 degrees in excess of that acquired by the cross compound.

The simplicity of the cross compound pump will be appreciated when it is stated that the valve gear is practically the same as that of the 9 1/2 in. and

11 in. pumps. The high pressure steam piston with its hollow rod contains the reversing rod which operates the reversing valve, and it in turn the main valve which controls steam admission to and exhaust from both the steam cylinders.

The low pressure steam and high pressure air pistons are connected with a solid piston rod, having no connection with the valve gear, and being simply floating pistons.

The results of these comparative tests were of a character to prove conclusively the superiority of the cross compound design of pump over the duplex in every respect, and such was the consensus of opinion of all those witnessing the demonstrations.

Some years ago there was a somewhat humorous take-off on a well known advertisement which appeared in the pages of the London Punch. The artist, Mr. Harry Furniss, very cleverly drew a picture of a most disreputable tramp sitting, pen in hand, at a table and writing a testimonial to the makers of a popular toilet soap. The tramp wrote in all sincerity, "Three years ago I was induced to use your soap, since then I have used no other." The appearance of the man thoroughly justified his words. The humorous skit was brought to mind lately by receiving a circular about U. S. metal polish paste, and we came to the conclusion that we had seen a good many metal surfaces, once bright and clean, which were by this time in



the tramp's condition. The maker of this polish does not believe that harking back to the days of long ago is the way to treat what are intended to be bright, shiny surfaces. He believes with the poet Longfellow, in acting in the living present, and for that purpose he supplies a metal polish paste which wages war upon all kinds of dirt and grime, when they get on a metal surface, and with the U. S. Polish on your side you become a winner in that war. To be more strictly accurate, let us say that in our opinion you don't need to have the metal polish on your side, except in a moral sense; you get the polish on to the metal surface you desire to clean, and on applying what is called "elbow grease," the dirt gives up the unequal struggle and leaves for parts unknown. Write to George William Hoffman, of 295 East Washington street, Indianapolis, Ind., and ask him where the polish ought to be, in his hands or in yours? — on your side or on the metal surface? and we feel sure he will tell you all he knows about the subject, for he has thought it all over carefully.

### Duties of the Foreman.

At the recent meeting of International General Foremen's Association, Mr. G. W. Keller, general foreman of the Portsmouth (Ohio) shops of the Norfolk & Western, presented a paper on the Duties of the Foreman. He said:

The duties of the foreman cover a wide area of responsibility. When promoted to the position of foreman by his company, or his superiors, it is an acknowledgment that his superiors take an interest in him and are giving him a start in life that should be appreciated, and he can make his appreciation known by being loyal to his company and superiors. He must lay aside willingly, and with good heart all foolishness and any bad feeling that may have been existing between him and his superiors. He must do everything in his power for the welfare of his company, and must help his brother foreman maintain all shop rules and standards; apply discipline when necessary; try and keep harmony among the men; be quick in what he does to have them try to follow him; see that the time is kept correctly, and see that all men start to work at the proper time and keep on working until time to quit, and see that they are well supplied with tools and good care is taken of them; be sociable to the men; he must advise them how he wants the work done, and he must not say "go and do so and so," for if he does, his success will not last, as we have lots of mechanics to-day who are specialists; a foreman may have a few of them that will require attention. He may start the man on something that he has probably never done before, and with frequent instructions to him he may do a good job and make a good man; for no good mechanic will refuse or get mad if the foreman wants to show him how he wants his work done.

He must see, when the work is taken down, that it is properly cleaned and sent to the respective shop it should be, and kept followed up closely to see there is no detention to it. He must see that all good material is taken care of and not thrown among the scrap; it may be that it cannot be used for what it was intended, but it may be good for something else. Here is where many a good foreman has failed by allowing good material to go to the scrap pile. He must see that material is kept on hand sufficient to not hold his work, yet not too much so; that when his semi-annual inventory is taken he will not be criticised for having too much material on hand. He must be positive in his commands, must not cut or snap his men off, for he will find that this will hurt him more than anything he can do; he must speak to them as he would desire to be spoken to.

The foreman must see that the premises and shops are kept clean, the cupboards and vice benches are not broken,

bent or out of position, and that there is no scrap piled up under them; also see that his shop is in a sanitary condition. He must be loyal to all the other foremen and assist them all he can, for when assisting them he is assisting his superiors to help him along. The foreman must not let something go that should be attended to, simply because it is some other foreman's business who should have seen to it. This is a bad practice, and has caused lots of trouble in many cases, and I do not think much of a foreman who will practice this, as he is working against his company and getting his brother foreman into trouble.

There is nothing more beneficial to any shop than that the foremen work in harmony with each other and help each other; he owes this to his brother foreman, and shows that he is working to the interest of the company, for no foreman can be loyal to his company and

when your minds are not just on your work. You can listen and pay more attention to what your brother is saying; you have no opportunity and no right to get together during working hours to discuss any question that may arise pertaining to your duty; therefore, you should encourage these meetings. The foreman that has at heart these weekly or semi-monthly meetings is deriving good results from them and your superiors can see that they have a shop of interested foremen, and will look to your interest a great deal quicker than if you were asleep in the mechanical world. The advancing foreman of today must be up to new ideas and keep moving; he has no time to sit with his hands folded.

The necessity for mechanical literature is the foundation of success; what would this world be without mechanical literature? We would not be able to

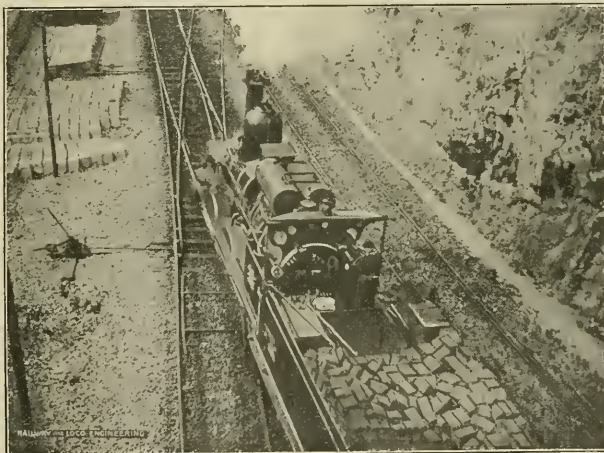

NEARING MONTE CARLO—VIEW FROM OVERHEAD BRIDGE.

work against his brother foreman, and sooner or later his superiors will call him up to answer charges that will probably get him into trouble, and he will be sorry for what he has done; yet his superiors having caught him in this will have a bad opinion of him and may never be able to do anything to advance him further; and right here is probably where he has lost the chance of his life; so be loyal to each other—it pays.

He should assist and encourage all weekly and semi-monthly shop meetings for the foremen; these are wonderful meetings, as a great deal of good can be derived from them, as he can learn something new at every meeting, as from one meeting to the other, some one of the foremen has learned something new that will be of interest to him.

Applying this to my hearers, I say here is where all can only get together,

see what our next-door neighbor was doing. The good, energetic mechanic waits hourly for his journal of mechanical literature to come; how would our minds be enlightened if it was not for this? We would never have anything before us that would give us any reason to improve or make improvements. Every month there is something new that is very beneficial to the mechanic, and right here, I am sorry to say, there is not one-half of the mechanics reading these good books that should be.

This country has produced some of the finest graduates in the mechanical line that there is, and it is just such as these who are studying modern mechanical methods and improvements that when the results are published they are of service to you and me. I think if all the foremen would stop long enough to think, where am I in this hustling, mod-

ern, improved mechanical world, they would subscribe for more mechanical literature, or at least for some railway journal.

#### Patent Office Department.

Many of our master mechanics on the various railroads have from time to time perfected important improvements on the details of the locomotives. These men are daily brought into contact with the growing necessities that arise from

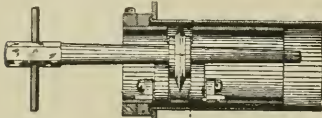

TUBE CUTTER.

constantly increasing traffic, and many excellent ideas have come from them. In our selection this month there is a clever device described; it is for holding the crosshead and piston together. It is the work of a master mechanic on one of the Texas railways. Among other ingenious devices we select the following:

#### TUBE CUTTER.

A very clever contrivance for cutting flues in a boiler has been invented and patented, No. 818,135, by Mr. Alfred Warren, San Lucas, Cal. The apparatus consists of a sleeve loosely turnable within the tube to be cut, having a collar to bear against the outer end of the tube and flue sheet, rollers journaled within the sleeve having their peripheries projecting through slots, a circular V-shaped cutter having a hollow hub and turnable between the interior periphery of the rollers and a tapering spindle adapted to pass through the cutter hub, and adjustable means whereby the spindle and sleeve are revolved.

#### ADJUSTABLE BEARING FOR ROD BRASSES.

Mr. S. Webster, Minneapolis, Minn.,

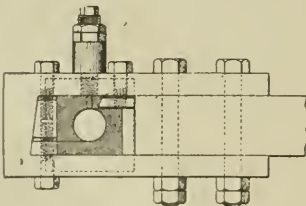

ROD BRASS BEARING.

has patented an improved adjustable bearing for rod brasses, No. 818,319, consisting of a combination with a rod and strap, of a two part bearing box divided on parallel lines that join tangentially with the bearing surface thereof, and a pair of independent opposing screw actuated wedges for adjusting and setting one of the said box sections with

respect to the other section whereby the degree of tightness and exact location of the center of the brass may be readily adjusted.

#### PISTON ROD CONNECTION.

A contrivance for attaching a piston rod to a crosshead without the use of a key has been patented, No. 818,277, by Mr. Charles T. McElvancy, Denison, Tex. The combination consists of a crosshead having a tapered opening, a piston rod having a front and rear taper, the rear taper fitting the crosshead, a split sleeve fitting over the first taper, and a binding nut engaging the crosshead and binding the split sleeve on the front taper of the piston and also binding the rear taper against the wall of the crosshead, thereby holding the rod and crosshead firmly together.

We illustrated this clever device in the October, 1905, issue of RAILWAY AND LOCOMOTIVE ENGINEERING, on page 447, when Mr. McElvancy was experimenting with a view to doing away with the key and waylock usually in use.

#### LOCOMOTIVE ENGINE FRAME.

Mr. Clarence H. Howard, St. Louis, Mo., has patented an improved locomotive frame, No. 818,448. The combination consists of an end sill attached to

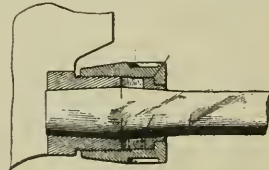

PISTON ROD CONNECTION.

the longitudinal frames of a locomotive. The sill has a central transverse opening for the drawbar, a pocket for holding the drawbar, and means for attaching the pockets to brackets having their outer lateral portions adapted to bear against the inner sides of the frames, and means for fixing the brackets to the frames.

#### AXLE BOX LUBRICATOR.

An ingenious contrivance for lubricating locomotive axles and refilling driving box cellars without removing the main cellar has been patented by Mr. Albert G. Elvin, Franklin, Pa., No. 818,022. The device consists of a main axle box cellar which is open at its outer end, a plate detachably connected to the outer end of the main cellar, an auxiliary lubricant cellar located in the main cellar and removable therefrom when the outer plate is detached, and having a perforated top plate curved to fit an axle journal, a follower plate fitting freely in the auxiliary cellar, and a spiral spring interposed between the main cellar and the lower side of the follower plate.

#### BRAKE SHOE.

Mr. Charles W. Armbrust, Chicago,

Ill., has patented an improved brake shoe, No. 817,894. The brake shoe is fitted with filling and spacing lugs on its back, the lugs having tongues formed upon the sides of the shoe, in combination with attaching members, slidably engaging the tongues and provided with apertured lugs for engagement with a key whereby the shoe is readily connected with the head. The device has the merit of allowing the shoe body to be entirely worn out without danger of

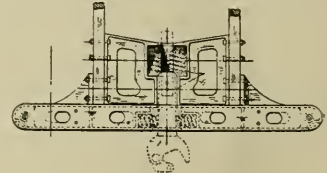

LOCOMOTIVE END SILL.

wearing the head even if the shoe should be unevenly worn.

#### PISTON ROD PACKING.

Mr. Edward Bader, St. Louis, Mo., has patented a packing for piston rods, No. 818,658, consisting of a casing formed of two semi-cylindrical parts, with a number of grooves formed in both parts of the casing, a pair of splines set into the casing across the line of junction to prevent relative longitudinal movement between the parts, and a pair of expandible rings arranged side by side in each groove, each ring being composed of a plurality of separable parts, the junction of one ring facing the solid parts of the adjoining ring.

#### JOURNAL BOX.

A railway journal box has been patented by Mr. James R. Williamson, Chicago, Ill. It comprises a casing, a bearing in the casing for engaging the journal, the casing having in one end an opening adapted to permit the removal of the bearing, a cover adapted to be secured over the opening to prevent the removal of the bearing while the cover is in position, the cover

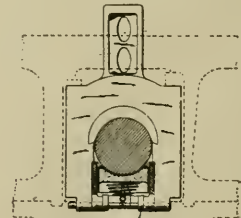

AXLE BOX LUBRICATOR.

having a handhole for permitting access to the interior of the casing but of insufficient size to permit the removal of the bearing, the handhole being wide at its lower part and narrow at its upper part.

### Pooling Engines.

When the subject of pooled engines came up at the recent St. Louis meeting of the International General Foremen's Association, Mr. J. C. Wilkinson presented the committee's report, which was signed by himself and Messrs. J. W. Crysler and J. J. Moore. Mr. Wilkinson made a few preliminary remarks, and among other things said:

Pooling engines was born of the conditions that produced a shortage of power at a time of extremely heavy traffic, and was then in the nature of an expedient, or experiment, aiming to keep the power in continuous service, even at the expense of the engine failures and an increased cost of operation, or, to use a homely comparison, the railroads pooled their engines for the same reason that a man wears his Sunday shoes every day—that is, he is short on shoes.

It appears to be the general opinion that enginemen will not take the same interest in a pooled engine that they would in a regular assigned one, which is a most essential thing. Your committee sent out a number of inquiries to officials located at different points, and it would seem the conditions governing in the different parts of the country color the different replies received in answer to these inquiries, some of the northern roads favoring pooling and claiming good results therefrom, while the majority of the answers from the Southwest are decidedly against pooling. We have been unable to get any positive data from the eastern part of the country, but our observations and general knowledge received through various publications shows that some of the leading roads in the East consider pooling the proper way to handle the power. While the few in favor of pooling give good reasons for their preference, yet by far the greater number are decidedly against it. This being the case, your committee has given you what might be termed a minority report, as the member of the committee furnishing this paper is practically alone in his advocacy of pooling, but we feel that it is only justice to the association to give the report entire, which is as follows:

"This question is a very broad and deep one, and has been discussed pro and con by all classes of railway men, from the fireman to the general manager, and there are but few of our railway journals (our best educators) that have not taken a hand in the debate. It was interesting, if not convincing, to note what a determined stand the engineers took in opposition to the system, and no wonder, for it was taking away from them that inbred sense of ownership of the machine that for many years they had cared for, and felt responsible for. They took a pride in it, and, as far as possible, kept it in good condition.

We do not blame them for opposing the pooling system, even when they expressed their sentiments in such strong (if not eloquent terms) that the foreman preferred to argue the question with them over the telephone when they found their engine had gone out with the 'other fellow' without so much as 'by your leave, sir.'

"The system had also a decided opponent in a majority of the roundhouse foremen, and from their viewpoint it was declared to be a decided failure, because of the increased cost of repairs, and the demand of the management to turn the engines out to service with the least possible delay. This did not mean to turn them out unfit to make a safe trip over the division, but to rush the repairs, and give to the trainmaster and train dispatcher, at stated periods, or hours, day and night, a statement of the situation at each roundhouse, showing what engines were there on hand, and when each would be ready for service.

"The advent of the pooling system was evidently going to impose many hardships on the roundhouse foreman, but if there was the right kind of timber in him, he kept pace with the evolution of the system and eventually became master of the situation.

"The system of pooling is highly favored by the train dispatcher, train master and superintendent, and we might say by the entire operating department, on the large railway systems where the traffic is heavy and the power scarce.

"The officials of the motive power department are aware that the power, where pooled, cannot be, or had not been, maintained at as high a state of efficiency as where engines are single crewed, or double crewed, and knowing this, they are prepared to submit to an increased cost for running repairs under the pooling system.

"A summary of the discussion of the International Railway Congress in Washington, D. C., in May, 1905, shows that in Europe the general sentiment is very much in favor of the single crew system, and unfavorable to the complete pooling, which is only used when necessitated by a sudden increase in traffic. They really admit that it is used when necessary. The same congress found that in America, pooling was very general for freight traffic, especially in time of a heavy increase in business. The organization of train service depends to a great extent on local conditions, and with the great feeders that the Chicago & North-Western Railway system has, reaching as it does into the lumber districts and the vast copper and iron mines of the northern States bordering the Great Lakes, and from the stock and grain farms of the western States and territories. These joining

the immense traffic pouring into Chicago causes a congestion of freight at their yards that is appalling, and they could see no better way than the pooling of freight engines to lift the blockade which was increasing every hour. Yardmasters and train masters not only in Chicago, but at several other large railway centers on the system, found it necessary to get the trains out of the yards to make room for other trains they were waiting to get in, and it is during such rushes of business that the roundhouse foremen's patience and endurance are taxed to the limit.

"When the pooling is formed by official decree, a large part of the responsibility in the care and inspection of the engines is taken from the shoulders of the engineers and placed upon the roundhouse foreman and his assistants; of course, this does not relieve the engineer from the duty of making out a report, and of calling attention to such defects as the roundhouse inspector could not detect, such as engine not steaming, pounds and blows, hot bearings, etc. The inspector at terminals must be a careful and painstaking man, a machinist preferred of thorough roundhouse experience, and should have a good helper to assist him in making such repairs as he can, and what he cannot do, he reports to machinist foreman. A careful and thorough inspection lends a greater degree of safety to our locomotives, and of course, to the men who are running them, and the engineers are beginning to recognize the fact that the pooling system is not increasing their duties, or burdens, but is rather relieving them of many responsibilities, which will become more and more evident as the roundhouse force becomes better organized to meet the new conditions. The system was forced upon us through circumstances, and as loyal employees we were elated and justly proud of the able management that had brought such prosperity to our country, and incidentally to our fellow employees.

"The locomotive itself was the machine that had to suffer most; it was earning nothing standing still; it was fulfilling its mission only while keeping the wheels revolving of a revenue-producing train, and while not in as good condition as when under the old system of being single crewed, the management was getting larger returns on the capital invested, and in a shorter time. This is the proof of the ability of the up-to-date business man of to-day, be he manager of a railroad or dry goods store.

"The busy locomotive brings in the revenue and has the most failures. Some of our able writers in the railway journals and mechanical periodicals have given figures to show the increase of engine failures under the pooling system, as compared with the failures under the

single crew system. This does not prove anything. On a division where the freight engine makes an average of 4,500 miles per month, there is bound to be more failures than where they only make 3,000 miles per month, and there is also bound to be greater earnings per engine. It is not expected that the engineer can keep pace with the continuously revolving wheels of the completely pooled locomotive. No man can keep up with the working capacity of the machine. Man must have physical and mental periods of rest, and while he is getting this needed rest the locomotive can go out with a fresh crew and haul in another revenue-producing train, and be ready for a third trip before the human machine No. 1 is sufficiently rested. Many engineers who were at first its strong opponents, are now becoming converted to the idea of pooling, and as time goes on, I firmly believe that you will find a greater number each year favoring the system. It has passed the experimental stage and the management has seen the traffic can be handled with a lesser number of engines than under the old system. They are keeping the engines busy, which is proper, and they want them kept in good condition, which is also proper, but is more of a problem for the roundhouse foreman. The division superintendent as well as the general superintendent is year by year taking more and more interest in the motive power department, and are holding themselves (in a measure) jointly with the master mechanic, responsible for engine failures—in other words, there is more co-operation and harmony to-day existing between the operating department and motive power department than ever before, and while working thus, and the necessity arises to pool the freight engines, they will surely make the system a success."

#### Electrification on the Pennsylvania.

Up to the present time the principal advance in the electrification of steam roads has taken place at the terminal stations or upon branch roads, so that the recent decision of the Pennsylvania Railroad to electrically equip a portion of their line between Camden and Atlantic City is of interest.

The portion of the Pennsylvania which will use electric traction comprises some sixty-four miles of road, being a portion of the West Jersey and Seashore branch. It is proposed to utilize the Cape May line of this system from Camden as far as Newfield, this line being double tracked with 100 lb. rails, and to build an additional track from Newfield to Atlantic City, making the lines double track throughout.

Over this roadbed an express service will be established. The initial installation will provide for a three-car train

every fifteen minutes between Camden and Atlantic City, making the sixty-four miles in eighty minutes without stops. The maximum speed of the cars will be between 55 and 60 miles per hour.

In addition to this through service to Atlantic City, a half-hourly schedule is planned, consisting of two-car trains between Camden and Millville, 40 miles, and ten minute service of single cars between Camden and Woodbury, 8½ miles. Full service will call for 58 cars in operation, each equipped with two 200 h.p. direct current motors. These motors will be similar to those now being manufactured by the General Electric Company for the equipments of the New York terminal of the New York Central & Hudson River Railroad. The motors will be controlled by the Sprague-General Electric automatic multiple unit system.

Current will be furnished to the cars by the third-rail system, except on the sections between Camden and Woodbury, and Newfield and Millville where the cars will obtain the necessary current by an overhead trolley. The power house will be at Camden. From this power house transmission lines will be run to six sub-stations between Camden and Atlantic City, and a seventh sub-station at Millville to supply that section of the road lying between Millville and Newfield.

The contract calls for the completion of this road by July 1, 1906, in order to handle the heavy summer traffic. The electrical equipment will be furnished by the General Electric Company.

#### The Personal Equation.

Astronomers, when making very exact observations, test the powers of those who have to do with the actual recording of time. For instance, they test a man in order to see how long it takes him to press a telegraph key or some such instrument after he sees a certain thing take place. They test him often enough to get a satisfactory average, and they write it down like an equation. It may read something like this: "Robinson =  $\frac{1}{10}$  second." He would probably record as one-tenth of a second late a thing which happened at a certain definite instant, like the passing of a star over a meridian. By allowing for this personal element in all his observations the correct time can be got at. Paget had this practice of astronomers in his mind when he wrote: "In that which each man believes that he observes there is something of himself. For certainly, even on matters of fact, we often need the agreement of many minds, that the personal elements of each may be counteracted." This, however, may fairly be applied to the reading of books, for although you get something of the personal element of

the author in a book, constant reading helps you, perhaps unconsciously, to retain the facts presented after the personal element, often pleasant enough, has passed from your mind. Look over the following list of selected books we present this month:

"Machine Shop Arithmetic." Colvin and Cheney. This is a book that no person engaged in mechanical occupations can afford to do without. Enables any workman to figure out all the shop and machine problems which are so puzzling for want of a little knowledge. We sell it for 50 cents.

"Firing Locomotives." Sinclair. Treats in an easy way the principles of combustion. While treating on the chemistry of heat and combustion, it is easily understood by every intelligent fireman. The price is 50 cents.

"Skeevers' Object Lessons." Hill. A collection of the famous object lesson stories which appeared in this paper several years ago. They are interesting, laughable, and, best of all, they are of practical value to-day. \$1.00.

"Standard Train Rules." This is the code of train rules prepared by the American Railway Association for the operating of all trains on single or double track. Used by nearly all railroads. Study of this book would prevent many collisions. Price, 50 cents.

"Mechanical Engineers' Pocket Book." Kent. This book contains 1,100 pages, 6x3¼ ins. of closely printed minion type, containing mechanical engineering matter. It ought to be in the bookcase of every engineer who takes an interest in engineering questions. We use it constantly as a reference for questions sent to us to be answered. Full of tables and illustrations. Morocco leather, \$5.00.

"Locomotive, Simple, Compound and Electric." Reagan. An excellent book for people interested in any kind of locomotive. It will be found particularly useful to men handling or repairing compound locomotives. It is the real locomotive up to date. \$2.50.

"Simple Lessons in Drawing for the Shop." By O. H. Reynolds. This book was prepared for people trying to acquire the art of mechanical drawing without a teacher. The book takes the place of a teacher, and has helped many young men to move from the shop to the drawing office. 50 cents.

"Locomotive Running Repairs." By L. C. Hitchcock. This book contains directions given to machinists by the foreman of a railroad repair shop. It tells how to set valves, set up shoes and wedges, fit guides, care for piston packing, and, in fact, perform all kinds of work that need a thoughtful head and skilful hands. 50 cents.



## Old-Timer Talks No. 4



I remember a new engine we got once; the very first day she ran so hot she was laid up. Well, I had an idea

I could run that engine and so I got the master mechanic to let me take her out.

Before starting, I worked some of Dixon's Graphite, the pure, thin flake, in on her pins and boxes. Then I took her out on the express and when I brought her back she was cool as a cucumber. I ran her regular after that and was glad to get a new engine—she was a dandy.

I tell you there's nothing like Dixon's Graphite for new or old engines. Get that sample, No. 69-C, and see for yourself.



Joseph Dixon Crucible Co.

Jersey City, N. J.

### Simple vs. Compound Locomotives.

(Continued from page 277.)

gain of the compound is less on descending grade than on ascending. Repairs for six months show the simple engine cost 1 5/10 per cent. more for machinery repairs and 48 4/10 per cent. more for boiler repairs than the compound on a 1,000 ton mile basis. The heavy repairs to the simple engine were due to a door sheet cracked patched, then partially replaced, this due to more water used, more fuel condensed and severe action of exhaust on fire and furnace plates. The simple engine used 27 per cent. more fuel oil and 17 per cent. more water on ton mile basis, evaporated 5 per cent. less water per pound of fuel oil, and shows an efficiency of 14 7/10 per cent. in favor of the compound on all items of expense on ton mile.

The details showed the compound as 19 6/10 per cent. more economical on fuel and 18 4/10 per cent. on water, the actual ascending and descending economies being 22 1/10 and 12 8/10 on an average of 19 6/10 per cent. on fuel.

The greater amount of water used by the simple engine made it necessary on some tests to cut down the tonnage for the reason that the stationary water tanks in that section of the country were so far apart that this engine could not make the tanks with a full train, while the compound took full tonnage and had fair margin of water left on arrival at next tank. To this example and endorsement of the principle of computing steam, there is but one answer.

The published results of tests on the C., B. & Q. Ry., about one year ago showing economy of operation and general increased efficiency of service rendered by a four cylinder compound over a simple engine, or a number of simple engines, stands as an unquestioned endorsement of the compound principle. The results of the tests at the St. Louis Exposition, 1904, would also indicate that the compound principle was the correct one; in fact, the finding of the Board of Commission is unqualifiedly in favor of the compound. A comparison of two engines, one tested at St. Louis, with the simple under consideration this evening, shows the following variation in results obtained.

The simple engine was about the same general dimensions as the St. Paul engine, but with slightly less grate area and total heating surface. One evaporated 6 1/10 lbs. water per pound of coal, while the other evaporated 7 6/10, or 25 per cent., in favor of the St. Louis engine; average boiler efficiency, 56; for the St. Louis and for the St. Paul, 50, the St. Louis engine using a superior grade of fuel.

The tests at St. Louis not only brought out and established many practical and theoretical facts in connection

with locomotive design, construction and operation, but it thoroughly demonstrated the relative efficiency of single expansion vs. compounding steam, showing a coal consumption per demonstrated horse power per hour for simple freight engine from 3 1/2 to 4 1/2 at low speeds and at high speeds up to 5 per cent., the average probably being about 4 1/2 per cent. While compound freight engines were as low as a fraction over 2 lbs., to 3 7/10, or a range of efficiency in freight service, slow speed, from 21 to 38 per cent. in favor of compounding, the poorest compound showing a saving of fuel over the best simple of 10 per cent., while the best compound showed a saving over the poorest simple of about 40 per cent.

It should be of more than passing interest to note that one of the four compound passenger engines tested and which in some respects showed superior steam distribution, was equipped with a double or independent valve gear, making it possible to change the cut-off as between the two sets of cylinders to suit the varying conditions, a feature absolutely essential to the commercially successful application of the compound principle to any steam engine which carries a fluctuating load or is used under varying conditions of speed and service.

Next to the last conclusion by this board it is a very valuable addition to railway engineering literature. I quote it verbatim:

"It is a fact of more than ordinary significance that a steam locomotive is capable of delivering a horse power at the drawbar upon the consumption of but a trifle more than 2 lbs. of coal per hour. This fact gives the locomotive high rank as a steam power plant."

This conclusion or finding, it must not be forgotten, is predicated upon, and is a recognition of, the principle of compounding steam, and although the language used is not ambiguous this point may not be clear to all. There should be no misinterpretation, however, on the part of any who are interested in or have anything to do with railway engineering matters. "A word to the wise should be sufficient."

A range of difference of about 212 to 230 per cent., respectively, between the results given in the paper before us this evening, and the maximum possibilities in locomotive efficiency should stir into activity every operating head and motive power officer, who are not already bending their energies in the direction of increased locomotive efficiency and reduced cost of transportation.

I think a great deal of the trouble with compound engines over the country at different places—that is, compound locomotive engines, particularly the complaint about cost of repairing them—has

been due to the fact that the motive power officers of the railways have not, from some causes or other, co-operated as thoroughly and cheerfully as they should with the locomotive builders, to the end that a more efficient engine both from a standpoint of design and construction be produced. It is hard for some to separate, and I believe the majority of railroad men have failed to separate, the principle of compounding steam from the engineering, or questions of design involved in its application. It is true that in a physical sense they are associated together, as we see or apply them, but they are entirely two different questions. When the idea of compounding and carrying higher pressure on steamships was first introduced some years ago, they had similar troubles to the locomotive of to-day. Engines would not only break down and destroy themselves practically at times, but in some cases punched holes in the bottoms of ships while at sea. The engineers got together and designed a machine that would protect and take care of the compound principle with the result that a horse power is delivered at the paddle wheels or propeller wheels of a steamship to-day with about one and one-half pounds of coal per hour. It is not many years ago when they were consuming seven, eight and in some cases 10 to 12 lbs. Locomotives, I don't believe, can be brought to the high state of efficiency that marine engines, high duty pumping engines and those in large industrial concerns have attained, owing to the different character of service. They are exposed to weather conditions which mitigates against an engine not housed in, but when we have before our eyes verified reports and some have witnessed the practical tests, where a horse power has been produced at the drawbar of a locomotive with a fraction over 2 lbs. of coal, we should not rest content in consuming from 5 to 8 and shifting the responsibility to a defective machine which we can and should improve. Steam turbines, which have lately been introduced in land and marine service, are producing a horse power on 1.3 lbs. of coal per hour, while gas engines have a record of less than 1 lb. Electricity is coming into use as a motive power, and will be rapidly extended. This is a period of transition for the steam engine in certain service, and if the locomotive builders and the motive power officers do not exert themselves in this direction more in future than they have in the past few years, in developing a more economical unit, thoroughly reliable, they are going to find themselves struck by a storm of criticism that they cannot easily stay. I believe the language temperate and the figures conservative which predict that in a few years the motive power used for city, suburban and most light branch lines, will have undergone a complete change, and that the

bulk of heavy through passenger and freight trains will be moved with a consumption of approximately three (3) lbs. of coal per horse power per hour. The compound principle a few years ago, as has been said here to-night, was more popular than it is at present. Why should it wane? I think that there is no reason for it all, the fact being a reflection on our engineering ability. A locomotive engine can be built embracing the compound principle, a compound engine, and it can be built so that it will not break down on account of the compound feature; it can make equal regularity of trips as a corresponding simple engine of the same size, and when the comparison is made between the present day compound or simple with the little engines of fifteen or twenty years ago, it is unfair; there is no comparison between them at all.

Just one word about a matter that has already been referred to by a previous speaker, and that is, throwing out two of the tests shown in Mr. De Voy's paper. I think, as the others have said, that these tests should be left in, and as further evidence on the subject I will quote from Mr. Manchester's remarks on page 309, Proceedings of the Western Railway Club, of March, 1899, at which time they were discussing the relative merits of compound versus simple engines. Referring to a lot of 25 running on the C. & C. B. Division, which, I understand, is the same division in question, Mr. Manchester says: "I have looked up this question and I find that the engines' rating on this division is 1,200 tons, but that the average trains they have been hauling is 750," which is 60 per cent. of the rating, 40 per cent. less. Therefore, I don't think it would be right to throw out the two tests referred to because they were just a little below the rating.

I believe it was my good friend Wynne who called me to account a moment ago. I concede he is right to a great extent, but I can't fully agree that the condensing feature deserves all credit. It is not many years ago that in the operation of high duty plants, as we considered them then, for instance, the milling industry, a large flouring mill, to produce a barrel of flour it took 57 lbs. of coal; in fact, it was high as 62 to 65, with some automatic engines. Introducing the Corliss type of engine brought it down to 40 and below. Compounding the Corliss without any condensing apparatus brought it down still lower, and, finally, with the condensing arrangement, it was brought down until a barrel of flour was produced with a consumption of 16 lbs. of coal, and this, although considered remarkable at the time has been lowered several hundred per cent. in some of the large mills with compound condensing engines. Simple non-condensing engines, automatic, as a rule consume about 33.8 lbs. of water per horse

## The Best and Cheapest Books for Railroad Men

**AIR BRAKE CATECHISM** <sup>Price,</sup> **\$2<sup>00</sup>**

By Robert H. Blackall. 20th Edition. Contains 1500 Questions and their Answers on the Westinghouse Air Brake, which are strictly up-to-date. Includes two large Westinghouse Air Brake Educational Charts printed in colors. Gives the necessary information to enable a railroad man to pass a thoroughly satisfactory examination on the subject of Air Brakes. The author's many years' experience as Air Brake Inspector and Instructor enables him to know at once how to treat the subject in a plain, practical manner. Endorsed and used by Air Brake Instructors and Examiners on nearly every railroad in the United States. The standard and only complete work on the subject. 312 pages.

**LOCOMOTIVE BREAKDOWNS AND THEIR REMEDIES** <sup>Price,</sup> **\$1<sup>50</sup>**

By Geo. L. Fowler. Just issued. Tells how and what to do in case of an accident or breakdown on the road; includes special chapters on Compound Locomotives. Better proof a copy, as it contains 800 Questions and their Answers on Accidents and Breakdowns.

**LOCOMOTIVE CATECHISM** <sup>Price,</sup> **\$2<sup>00</sup>**

By Robert Grimshaw. 23d Edition. Is right up-to-date and contains twelve large Folding Plates and 1600 Questions and Answers on How to Run a Locomotive. The Standard Book on the subject, being written in plain language and free from mathematical formulae and complex problems.

**NEW YORK AIR BRAKE CATECHISM** <sup>Price,</sup> **\$1<sup>00</sup>**

By Robert H. Blackall. The only complete treatise on the New York Air Brake and Air Signaling Apparatus, giving a detailed description of all the parts, their operation, troubles, and the methods of locating and remedying the same. 250 pages.

**COMBUSTION OF COAL AND THE PREVENTION OF SMOKE** <sup>Price,</sup> **\$1<sup>50</sup>**

By Wm. M. Barr. Contains over 500 Questions and their Answers on the Science of Steam Making.

**AIR BRAKE CHARTS** <sup>Price,</sup> **50c.**

Showing the Westinghouse Equipment in ten colors, including freight and passenger engine. Every railroad man should possess these charts at this low price.

**A Special Circular** of any of these books sent on request. Any of these books sent prepaid on receipt of price.

**Agents Wanted at Every Terminal.** Write for our special terms. You can make equal to a month's pay selling our books on the side

**The Norman W. Henley Pub. Co.**

132 Nassau Street, New York, U. S. A.



# RAILROAD SUPPLIES Announcement

We have recently organized a RAILROAD DEPARTMENT to take care of our large and rapidly increasing business in Railroad Materials and Supplies. We are now making a specialty of Insulating Materials, Packings, etc., for this trade, as follows:

- Smoke Jacks
- "Transite" Fireproof Lumber
- Asbestos and Magnesia Locomotive Lagging
- Vulcabston Pump Packing
- Vulcabston Gaskets
- Vulcabston Rope Packing
- Train Pipe Covering
- Kearsarge Gaskets
- All grades of Asbestos and Magnesia Pipe Covering
- Hair Felt
- Keystone Hair Insulator
- Asbestos Cements
- Retort Cements
- Canadax Wick Packings
- High Pressure Asbestos Packing
- Asbestos Roofing
- Portland Sectional Conduit

WRITE NEAREST BRANCH FOR BOOKLET

## H.W. JOHNS-MANVILLE CO.

Manufacturers of Asbestos and Magnesia Products, Electrical Insulating Materials, "Noark" Fuse Devices, Electrical Railway Supplies, etc.

NEW YORK ST. LOUIS KANSAS CITY  
MILWAUKEE PITTSBURG MINNEAPOLIS  
CHICAGO CLEVELAND LITTLE ROCK  
PHILADELPHIA NEW ORLEANS  
BOSTON SAN FRANCISCO  
LOS ANGELES SEATTLE  
LONDON



per hour. The evaporative ratio of fuel would be about 4.2 lbs. bituminous coal, while a non-condensing compound engine of same type will do the same work on 26 lbs. of water, or a ratio of 2.8, a gain of 29 per cent., by compounding an automatic engine. By applying the condensing features and triple expansion we got down to 17 lbs. of water, or a ratio of 2.1 lbs. of fuel for an automatic engine; or an efficiency of 93.8 per cent. over single expansion. With Corliss engines the simple consumes 29 lbs., compound non-condensing 24 lbs.; an efficiency of 20.83 per cent. due to compounding. Triple expansion condensing 14 2/10 lbs., or a gain of 104 2/10 per cent. due to compounding and condensing.

While it is true that the condensing feature is a great factor in the saving effected, yet it is not wholly responsible, neither is it any reason because we can use the condensing feature on a steamship or in a high duty plant, that we cannot design, construct and operate a compound locomotive producing corresponding economies without the condensing feature.

### Cam Lever Draft Gear.

We are able to present illustrations of a new draft gear, manufactured by McCord & Co., of Chicago. This draft gear has a very high capacity, which in itself

ed in the McCord draft gear by a simple arrangement of cam shaped levers acting on the spring as the draw bar moves, the leverage decreasing as the load applied increases, the final result being that the capacity of the spring is increased about twelve times; thus the gear gives an ultimate resistance of about 250,000 lbs. when solid.

The best idea of the operation of the device is obtained by conceiving the coupler acting against the spring through a lever, and this connection between the

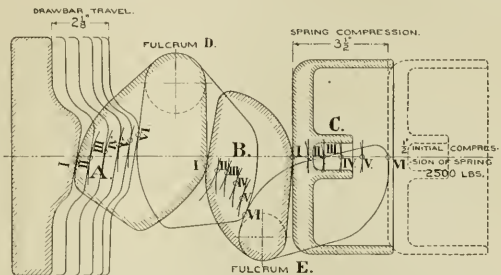
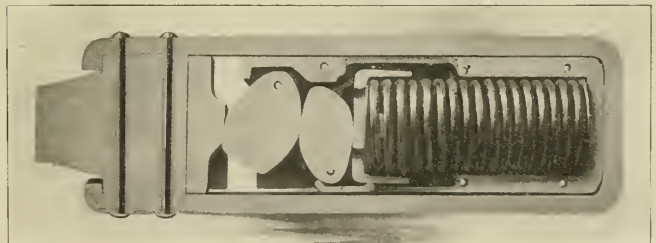

DIAGRAM SHOWING MOVEMENT OF CAMS.

spring and the lever is so arranged that as the coupler moves the spring is automatically moved out on the lever until at the end of the coupler movement the spring has gained an increased leverage against the coupler of about twelve to one. In order to get the device into compact form for application to cars this single lever, which we have been mentally picturing, is actually made in the form of two cam-shaped levers, and the variation of the leverage is secured by shaping these levers so that in rocking one upon the other the leverage is increased.

Reduced to practice the device is ex-



NEW CAM LEVER DRAW GEAR.

is interesting, but the principle involved is the striking feature of the device. The gear is not a friction draft gear, though friction is, of course, an unavoidable element in the operation of the device; it is, however, in no way essential to its operation. The draft gear is designed on the theory that the way to absorb the shock of a blow is through an elastic medium and not by means of friction producing surfaces. The principle of elastic resistance to shock is accomplish-

ed in the McCord draft gear by a simple arrangement of cam shaped levers acting on the spring as the draw bar moves, the leverage decreasing as the load applied increases, the final result being that the capacity of the spring is increased about twelve times; thus the gear gives an ultimate resistance of about 250,000 lbs. when solid.

The relation between the draw bar travel and resistance to load is worthy of notice, and it will be seen that plenty of coupler movement is allowed in order

to give adequate elasticity to the gear until the load is increased beyond ordinary service conditions and up to the maximum draw bar pull of any engine now built. After this point is reached the resistance increases very rapidly until the capacity of the gear is exhausted.

The diagram shows the operation of the cam levers at different points for the movement of the coupler until the gear is solid. In the position of the parts shown by the shaded lines position *I*, which is the normal position of the parts under no load except the one-half inch initial compression of the spring (equivalent to 2,500 lbs.), the follower plates are in position most favorable to their movement; that is, each is in position to act upon the longer arm of the lever. Otherwise stated, a load upon the front follower plate shortens the lever arm from the point of contact between the follower plate and the cam fulcrum *D*, lengthens the arm between fulcrum *D* and the point of contact of the two cams and shortens the arm between the point of contact on the inner cam and its fulcrum *E*. The arm between fulcrum *E* and the point of contact of the inner cam and the spring cap remains always the same, the result of this arrangement being that the load is at all times delivered at the central point of the spring. Under tensional load the action is, of course, similar. This action continues up to the limit of the capacity of the gear, and because of the rolling contact of the surfaces involved, is necessarily continuous during the continuance of the load and is transmitted through the spring to the underframe without shock.

It will be noticed that the capacity of the gear as indicated by the lever diagram, disregarding friction, is 200,000 lbs. During some tests the capacity was shown to be about 250,000 lbs. It thus appears that the frictional element entering into the device under its heaviest load is 20 per cent. of its capacity, and from this point it decreases to a negligible quantity.

In mediæval times the throwing down of a glove was the form in which a challenge was generally given, and that is practically what a Detroit concern has done when they state that in buying their goods you get a bona fide, tried and tested, copper-clinched bargain. The old-time way to accept the challenge was to pick up the glove; the modern way would be to get a pair of these F. P. Sargent gloves and see if what is said about them is true. The first thing to do if you do not know what the gloves are like is to write to the company and ask for a leather match safe, made out of the same kind of stuff that the gloves are. The match safes are free for the asking, and so is the catalogue, which is illustrated in colors. In this way you get in touch

with the firm, then you become better acquainted and perhaps later on you may actually be hand-in-glove with them. They do not wish you to form an off-hand opinion of their goods; they want you to put on the gloves and square up to them and they will try to be square with you. The catalogue with the illustrated leaflets shows three kinds, each in several styles, of wrist gloves, gauntlets and auto gauntlets, made from selected tough chrome tanned leather. You can fire or run an engine with these gloves, and they save coal—from getting on your hands. If you want a sample of the leather write to the Detroit Leather Specialty Company, of Detroit, Mich., and ask them to send you their match receptacle. This is quite a safe thing to do, and the catalogue will go with it. The gloves are called Sargent's, but they would fit a colonel.

The Electric Properties Company, incorporated May 10, under the laws of the State of New York, with a capital of six million preferred and six million common stock, has been organized to acquire, finance and develop properties, either whole or in part, especially those in which electricity plays the principal part, such as power, electric traction and electric lighting enterprises and to invest and deal in and to guarantee the securities of corporations operating such properties. It will also conduct through Westinghouse, Church, Kerr & Company (all of whose capital stock is owned by the new company) a general engineering and construction business. It may also issue collateral trust bonds secured by the pledge of securities acquired in the course of business. Mr. John F. Wallace has been selected as president of the new corporation, and two vice-presidents will be elected at the first meeting of the board of directors.

The following gentlemen constitute the directorate, all of whom will be actively interested in the conduct of the business of the Electric Properties Company: Messrs. Charles H. Allen, vice-president, Morton Trust Company, New York; Paul D. Cravath, Cravath, Henderson & De Gersdorff, New York; H. D. Giddings, New York; N. W. Halsey, N. W. Halsey & Company, New York; George C. Smith, vice-president, Security Investment Company, Pittsburgh; John A. Spoor, president Union Stock Yard & Transit Company, and president Chicago Junction Railway Co., Chicago; Moses Taylor, of Kean, Van Cortlandt & Co., New York; E. G. Tillotson, vice-president, Cleveland Trust Company, Cleveland; F. D. Underwood, president, Erie Railroad, New York; R. B. Van Cortlandt, Kean, Van Cortlandt & Co., New York; John F. Wallace, president, Electric Proper-

# GOLD Car Heating and Lighting Co.

Manufacturers of

**ELECTRIC,  
STEAM AND  
HOT WATER  
APPARATUS  
FOR RAILWAY CARS**

**EDISON  
STORAGE  
BATTERY  
FOR RAILWAY CAR  
LIGHTING**

Largest Manufacturers in the World  
of Car Heating Apparatus

Catalogues and Circulars  
cheerfully furnished

Main Office, Whitehall Bldg.  
17 BATTERY PLACE  
NEW YORK

# Homestead Valves

Straightway, Three-way and Four-way, and

# Homestead Locking Cocks

Are Famous the World Over

They cost more, but are worth very much more than other makes. You try them and see.

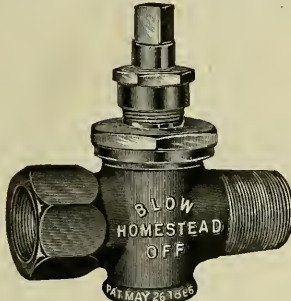

Brass, 1 1/4 in., \$6.00 net

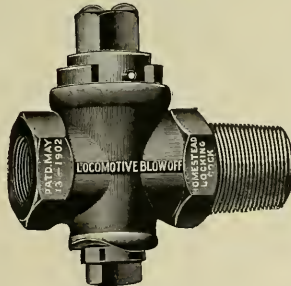

Iron Body, Brass Plug, 1 1/4 in., \$4.00 net

## Homestead Valve Mfg. Co.

WORKS, HOMESTEAD, PA. PITTSBURG, PA.

## American Locomotive Sander Company

13th & Willow Sts., Philadelphia, Pa.

Proprietors and Manufacturers

LEACH, SHERBURNE, DEAN, HOUSTON, "SEE" and CURTIS SANDERS

### THE ROBERT W. HUNT & CO.

Bureau of Inspection, Tests and Consultation, 1137 THE ROOKERY, CHICAGO.

66 Broadway, New York. Park Building, Pittsburgh. 31 Norfolk House, London, Eng.

Inspection of Steel Rails, Splice Bars, Railroad Cars, Wheels, Axles, etc. CHEMICAL LABORATORY—Analysis of Ores, Iron, Steel, Oils, Water, etc. PHYSICAL LABORATORY—Test of Metals, Drop and Pulling Test of Couplers, Draw Bars, etc. Efficiency Tests of Boilers, Engines and Locomotives.

ties Co., New York; George Westinghouse, president, Westinghouse Electric & Mfg. Co., Pittsburgh. The headquarters of the company will be in New York.

### Cylinder Boring Machine.

The Barrett No. 6 Locomotive Cylinder Boring Machine, built by the Barrett Machine Tool Co., of Meadville, Pa., is designed for simultaneously boring and facing locomotive cylinders up to 30 ins. in diameter, and when boring piston valve cylinders it is provided with a cross-table, so that after the cylinder is bored and faced the boring bar can be withdrawn and the cylinder moved over by ratchet lever for boring and facing the piston valve at same setting.

The bed is 15 ft. 5 ins. long, widened portion 72x64 ins. long, 18 ins. high with platen top, having eight cross tee slots and two cross tee slots running

tight and loose pulley on the countershaft is 16 by 5 ins.

The machine is especially strong and rigid, and is designed in order to secure efficiency under modern conditions, such as high cutting speeds, deep cuts, coarse feeds with self-hardening steel.

### General Foremen's Assn. Exhibits

Adreon & Co., St. Louis, Mo.—Adreon-Morse ratchet wrenches, the Simplicity bell ringer, Back-up valve and whistle, "Security," Bordo blow-off valve and swing joints, armored flexible air hose, Brown's metallic window strip, models of Fewing's car replacer, some drawings of Dickinson's smokejacks and steel water tanks. The exhibit was in charge of Messrs. E. L. Adreon, Jr., E. W. Hodgkins, J. O. F. Clark and J. W. Gerhard.

American Steel Foundries, Chicago.—Janney coupler, Andrews cast steel truck, models of cast steel bolsters, various examples of steel castings. Simplex

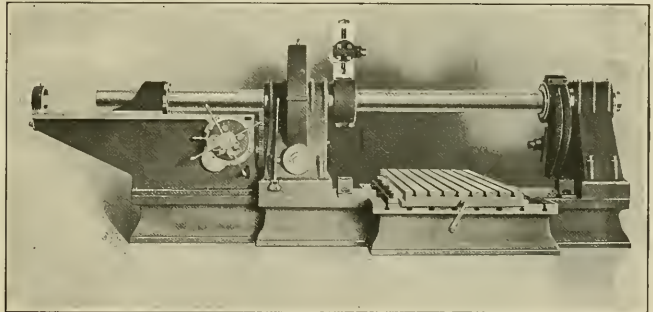

LOCOMOTIVE CYLINDER BORING MACHINE.

lengthwise. The machine has a continuous feed travel to boring bar in either direction of 60 ins., and will bore and face both ends of a cylinder at same time, thus producing the maximum of work in a given time. The boring bar is 8 ins. in diameter, made of hammered steel, with taper hole in end and has a quick travel in either direction by power. The pedestals are regular 32 in. from top of bed to center of boring bar, and the tail pedestal is adjustable on the bed, by power. Power is transmitted by the Hindley type, worm and worm wheel, ratio 85 to 1, single left hand thread, affording a very smooth and even motion to the boring bar, which is particularly desirable in cylinder boring. The machine is equipped with a patent quick change feed box mechanism, having fourteen different change feeds, any of which can be called into action almost instantaneously. The cone pulley has six steps 4 1/2 ins. wide by 13, 16, 19, 22, 25 and 28 ins. in diameter, with corresponding cone on countershaft. The

brakebeams, bolsters and springs. Davis cast steel car wheels. Those in charge were Messrs. J. V. Bell, T. D. Kelly, T. B. Harris and W. D. Lowry.

Bowser, S. F., & Co., Fort Wayne, Ind.—Self-measuring oil tanks and pumps, oil house equipment and system of storage. Represented by Messrs. C. A. Dunkelberg and W. T. Simpson.

Browning Engineering Co., Cleveland, Ohio.—Views of locomotive cranes loading freight on cars; coal, ashes and storage equipment, loading machine placing logs on cars. Exhibit in charge of Mr. H. R. Butler.

Burgess, B., Danville, Ill.—Models of the Burgess rail anchor for wrecking operations and Schott incline jacks. Represented by Mr. B. Burgess.

Carborundum Co., Niagara Falls, N. Y.—Carborundum grinding wheels for all purposes, oil stones, and all sorts of sharpening stones, carborundum grains for polishing and joint grinding, carborundum cloth for shop use. Exhibit in charge of Messrs. C. O. Taylor, W. W. Sanderson and C. C. Schumaker.

# World's Fair

St. Louis

FIRST PRIZE FOR

# TOOL STEEL

AWARDED TO

# McInnes Steel Co.

CORRY, PA.

in competition with the best makes in England and Germany. Also manufacturers of all kinds of Tool Steel, Die Blocks, and Steel Forgings.

Write for Prices and Information

STANDARD MECHANICAL BOOKS  
FOR ROAD AND SHOP MEN  
BY CHAS. McSHANE

The  
Locomotive Up to Date

Price, \$2.50

New York and  
Westinghouse Air Brakes

Price, \$1.50

One Thousand Pointers for  
Machinists and Engineers

Price, \$1.50

All books bound in fine cloth

AGENTS WANTED everywhere; write for terms and descriptive circulars. Will be sent prepaid to any address upon receipt of price.

**GRIFFIN & WINTERS**  
171 La Salle Street, CHICAGO

Chicago Car Heating Co., Chicago, Ill.—Sectional parts of apparatus demonstrating vapor and steam heating systems of car heating, also sectional parts of hot water heating specialties, safety valves, combination valves and filling devices. Represented by Mr. E. A. Schreiber.

Chicago Pneumatic Tool Co., Chicago.—Duntley air cooled electric drills, pneumatic drills, chipping and riveting hammers, air compressors and a full assortment of pneumatic air tools and electric drills. In charge of Messrs. C. E. Walker and J. C. Campbell.

Colcord Railroad Machinery Co., St. Louis, Mo.—Lodge and Shipley machine tools, Western Tool & Mfg. Co.'s Champion tool, Usona milling cutters, Reinsenweber tube expanders, hacksaw blades. Exhibit in charge of Messrs. J. H. Bentzen and A. R. Maness.

Columbus Pneumatic Tool Co., Columbus, Ohio.—Dunlap drills, U. & W. drills, Ulrich tube expander. Represented by Messrs. W. C. Kalb and Edward McArdle.

Commonwealth Steel Co., St. Louis, Mo.—Thermit for various welding purposes, and samples of welded metal. Thermit outfit ready for welding locomotive frames in place. Model of locomotive with driving wheels counterbalanced after the Davis system. Davis locomotive wheel machine for testing counterbalances of driving wheels, model of transom draft gear, showing coupler attached to body bolster by cast steel extension piece. Represented by Messrs. Clarence H. Howard, H. M. Pflager, A. T. Morey and A. R. Thomas.

Davis Expansion Boring Tool Co., St. Louis, Mo.—Expansion boring tools for car wheel boring and general locomotive work. Represented by Mr. E. E. Davis.

Flannery Bolt Co., Pittsburgh, Pa.—Samples of the Tate flexible staybolt as used in locomotive and other boilers. Exhibit in charge of Messrs. J. R. Flannery, T. R. Davis and W. M. Wilson.

Franklin Railway Supply Co., Franklin, Pa.—Locomotive driving box lubricator, McLaughlin's flexible joint and lock nut. Represented by Messrs. A. G. Elvin and W. D. Hurley.

Garlock Packing Co., Palmyra, N. Y.—New locomotive piston packing, all pump and throttle packings, packings for general shop purposes. Exhibit in charge of Mr. John N. Todd, the company's manager at St. Louis, and Messrs. F. A. Ebert, J. P. Landreth and H. P. Thursby.

Hannold Hose Coupling Mfg. Co., Mexico, Mo.—Gravity coupling for locomotive and railroad shop work. Represented by Messrs. E. J. Hannold and Frank Coatsworth.

Independent Pneumatic Tool Co., Chicago.—Thor pneumatic piston drills,

## Locomotive Blow-Off Plug Valves

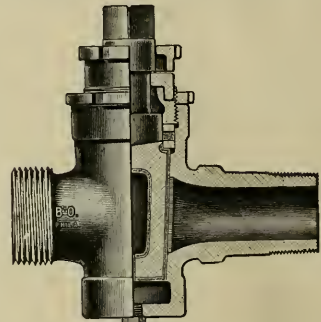

Fig. 9.

All Brass, extra heavy, with Cased Plug. For 250 lbs. pressure.

Made with Draining Plug to prevent freezing.

## Locomotive Gauge Cocks

For High Pressure

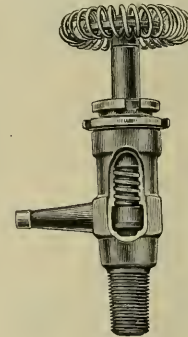

Fig 23, with Wheel.

Bordo Self-Grinding Gauge Cocks, made with renewable Hard Bronze Disc. Opened and closed with a quarter turn. Guaranteed Steam tight under the most exacting conditions. Shanks Threaded to specifications for Locomotives.

## Swing-Joints and Pipe Attachment

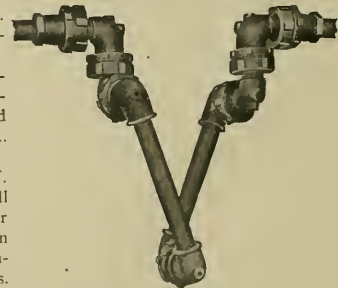

Fig 33.

May be applied between Locomotive and Tender.

These Swing-Joints are suitable for Steam, Gas, Air, Water or Oil.

Complete Booklet on Application

**L. J. BORDO CO.**  
PHILADELPHIA, PA.

# One Year and Eleven Months'

## SERVICE

WITHOUT REPACKING, ON

### HIGH-PRESSURE LOCOMOTIVES

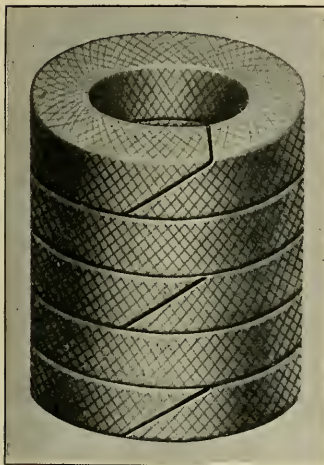

Style 300 TV.

A throttle failure is an absolute impossibility where Crandall's Throttle Valve packing is used.

IT WILL NOT BLOW OUT

## Crandall Packing Co.

FACTORY AND GENERAL OFFICE

PALMYRA, - NEW YORK

BRANCHES

New York  
136 Liberty St.

Cleveland  
9 So. Water St.

Chicago  
52 West Washington St.

# Patents.

GEO. P. WHITTLESEY

McDILL BUILDING WASHINGTON, D. C.

Terms Reasonable. Pamphlet Sent

## Compound Locomotives

By FRED H. COLVIN, M.E. Tells everything an engineer needs to know about all kinds of American compound locomotives. \$1.00.

ANGUS SINCLAIR COMPANY

136 Liberty Street New York

Thor wood borers, pneumatic chipping and calking hammers, Thor long stroke riveting hammers and various pneumatic appliances. Represented by Messrs. J. D. Hurley and Geo. A. Gallinger.

Ingersoll-Rand Co., New York.—Haeseler and also Imperial pneumatic tools, breast drills, riveters, chippers and reamers, sectional views of chipping hammer and Imperial motor air drill. Exhibit in charge of Messrs. A. A. Bon-sack, S. L. Hills, J. E. Campbell and E. A. Sageman.

Thompson, C. A., St. Louis, Mo.—Representing the Chicago Pneumatic Tool Co., the Pratt & Whitney Co. and the Shelby Steel Tube Co. The exhibit comprised Acme pneumatic sledge, pneumatic drills and hammers, Duntley air cooled electric drills, a Chicago pneumatic painting machine, Pratt & Whitney small machine tools. In charge of Messrs. C. A. Thompson, Ira Kegler and A. E. Conrow.

Republic Railway Appliance Co., St. Louis, Mo.—Models of Republic friction draft gear, Hutchins metal and plastic car roofs, samples of Spear & Miller insert brake shoes, North Birmingham turnbuckles, Jones positive nut locks, Republic front end enamel, Zephon boiler compound, Yankee wrench jaws. Represented by Messrs. E. S. Marshall, O. G. Mueller and H. T. Curd.

Ryerson, J. T., & Son, Chicago, Ill.—Working models of the Ryerson flue cleaning machine and the Morrison corrugated furnace boiler. Exhibit in charge of Messrs. J. T. Corbett and H. A. Ferguson.

### Break-Down Men Broken Up.

A curious state of affairs was revealed in a press dispatch from one of the middle States, a short time ago. It seems that a railway company out there adopted the monthly appropriation plan for shop operation and when the money ran out the shop was shut down and the men were sent home. This happened several times toward the end of various months and the men then found themselves with a few days of enforced idleness on their hands, when they were otherwise ready and willing to work and when, like many other people in the world, they felt that they needed the money.

During one of these monthly appropriation breathing spells, something ran off or smashed up on the main line and a hurried call for the wrecking train was sent in. Call boys, stenographers and clerks were dispatched in all directions to gather together the break-down gang. The men, however, while sympathizing keenly with the straightened financial circumstances in which the corporation found themselves, yet with great delicacy of feeling, steadfastly refused to compel the

# Tate Flexible Staybolt



Strong

Effective

Economical

Flexibility

Durability

Simplicity

Holds firebox sheets securely together, and accommodates itself to the unequal expansion of the plates.

## FLANNERY BOLT COMPANY

PITTSBURG, PA., U. S. A.

Suite 308, Frick Bldg.

B. E. D. STAFFORD, - - General Manager

Write us for Reference Book

# WASHBURN COMPANY

Minneapolis, Minn.

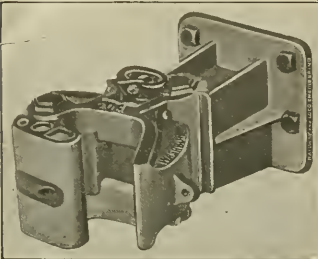

Automatic couplers for freight, engine and passenger service.

Draft riggings and buffer attachments for freight and passenger cars.

Special couplers for narrow gauge and plantation service a specialty. Steel castings of all descriptions.



## The Twentieth Century Master Mechanic

Won't use Solid Mandrels. Cost too much, take up too much room and don't give satisfaction.

### Nicholson Expanding Mandrels

Take everything from 1 to 7 inch holes. Take up little room — always ready and you can buy four sets for the cost of one of the solid kind

### Are You Using Them?

Catalogue tells you more about them.

**W. H. Nicholson & Co.**  
Wilkesbarre, Pa.

company to incur further monetary obligations by accepting their services, while the treasury was acknowledged to be short of cash. When the appropriation became due, on the first of the month, the whistle blew blithly again and the broken-up break-down gang were ready to wreck once more.

### Zephon.

Zephon Boiler Compound is comparatively a new product in the chemical and commercial world, having been on the market only a little over a year. By removing scale, and thereby increasing the heating capacity of boilers, this compound has in numerous instances reduced the coal consumption very considerably, and at the same time increased the life of the flues.

This compound does not contain any acid or other ingredients in any way harmful or injurious to the flues, crown sheets or boiler plates; in fact, it is said not to be even harmful to the delicate lining of the human stomach.

The Zephon Chemical Compound Company do not claim to have a panacea for all the ills that may affect boilers. They analyze the water used or the scale formed, and regulate the composition of their product accordingly. In localities where the water has a tendency to foam, this compound is adapted to "quieting the troubled waters."

To any one troubled with scale the company will send a sample of their compound, and also a demonstrator to show how to use it. Write direct for information, sample and man, if you desire to make a trial.

### Nerve.

A lady and gentleman were walking along the street together, when the gentleman said: "Do you see that man on the other side of the way? He is a brave fellow." "Indeed," she replied, "how do you know?" "I have seen that man," said he, "keep quite cool and collected under very trying circumstances, and when everything about him was pretty hot." "You amaze me!" said she. "Yes," he continued, "that man can actually whistle at danger, think of that!" "Oh my," she said, with feminine admiration in her voice, "how fine, how noble; who is he? What is he?" "Yes, he's all right; he's a locomotive engineer."

### Pipe Covering Contracts.

The H. W. Johns-Manville Company, through their Philadelphia branch, have recently completed two contracts for the installation of their various pipe coverings in the plants of two hotels in Atlantic City, N. J., The Marlborough-Blenheim and The Denis. In the plant of the former all of the hot, salt and

## This illustration shows the form of construction of the DART PATENT UNION

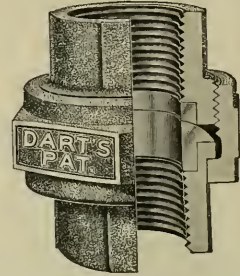

Every feature of construction represents the best points to insure stability and durability. The malleable iron pipe ends and nuts, in combination with bronze metal seats, are as near perfection as is possible to approach, and the sales to date indicate the public approval. There are none so good. For sale by all the principal jobbers in United States, Canada and Europe.  
**E. M. Dart Mfg. Co., Providence, R. I.**  
FAIRBANKS CO., SALES AGENTS.

## DIRECTORY OF RAILWAYS OF THE WORLD

The Universal Directory of Railway Officials, published in London, contains a list of the entire railroads of the world, with physical particulars and names of all officials.

Send Your Order Now for the 1906 edition.

Price \$3.00 Prepaid

**A. FENTON WALKER**  
Sole Representative for U. S.  
143 Liberty Street NEW YORK

A Practically Perfect Portable Pneumatic

## PUNCH

Stop moving your heavy work to the machine. One Man brings this tool to the work and punches it besides.

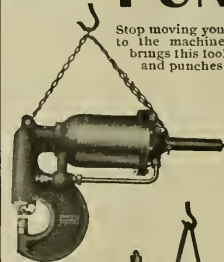

Punch Size 3

Built in 5 Standard Sizes. Special machines built to order. Write for Catalogue C.

**F. F. SLOCOMB & CO., Builders**  
WILMINGTON, DEL.

**SAVES TIME LABOR SPACE**

Leading concerns in all parts of the country use this Punch.



# THE UNION SWITCH & SIGNAL CO.

Consulting and Manufacturing  
Signal Engineers

Automatic Block Signals—Electric and Electro-Pneumatic

Interlocking—Electric, Electro-Pneumatic and Mechanical

Electric Train Staff Apparatus

GENERAL OFFICES AND WORKS AT  
SWISSVALE, PA.

DISTRICT OFFICES:

New York: 143 Liberty Street  
Chicago: Monadnock Block  
St. Louis: Frisco Building

## QUINCY, MANCHESTER, SARGENT CO.

(O & C COMPANY,  
Succeeding RAILWAY APPLIANCES Co.,  
PEDRICK & AYER CO.)

SOLE SALE AGENT  
ELASTIC NUT OR BOLT CO.

Old Colony Building  
CHICAGO

114 Liberty Street  
NEW YORK

Factories: (Plainfield, N. J.  
Chicago Heights, Ill.  
Milwaukee, Wis.)

Manufacturers of  
**Railway Machinery and Appliances**

## PATENTS

Our Hand Book on Patents, Trade-Marks, etc., sent free. Patents procured through Munn & Co. receive free notice in the

SCIENTIFIC AMERICAN  
MUNN & CO., 361 Broadway, N. Y.  
BRANCH OFFICE: 625 F St., Washington, D. C.

fresh water pipes are covered with their "J-M" moulded, and all steam pipes with their well-known "J-M" 85 per cent. magnesia covering. In The Denis, the entire heating system is covered with "J-M" 3-ply asbestos air-cell covering, and high pressure work with 85 per cent. magnesia. These coverings are only a few of the many standard coverings manufactured by this company, which have recently got out a very neat and attractive booklet, entitled "Pipe and Boiler Insulation," in which these materials are fully illustrated and described. A copy will be sent to those who are interested enough to write direct to the company. Those who go to the M. M. and the M. C. B. conventions will, if they wish, have a chance to look at the pipe coverings in the hotels referred to.

In the event of Congress making owners of refrigerator cars become amenable to the interstate commerce law as common carriers, the business of the private lines is likely to become less profitable. This condition would probably make them more willing to sell out to the railroads than they were some months ago when such a plan was under consideration. A new adjustment of their relations with the railroads is becoming imperative.

Among the many sufferers by the San Francisco earthquake and fire were the Berger-Carter Company, the Pacific Coast agents of the Falls Hollow Staybolt Company, of Cuyahoga Falls, O. The Berger-Carter Co. were formerly located at 34-40 Beale street, San Francisco; they have now opened a temporary office at Third and Washington streets, Oakland, Cal., and are carrying on their business on a larger scale than ever and have a new and extensive stock. They have shown ability and enterprise under trying circumstances and deserve success.

### Do You Know It?

At a recently held meeting of the New York Railroad Club, Mr. G. W. Wildin, mechanical superintendent of the Erie, in speaking of the style of roundhouses in use some years ago and still found on some railroads, said that a roundhouse was a circular structure with a questionable roof, a good deal of wall and next to no light. The applause which followed this definition was long and fervent and seemed to come from men who had at one time worked in that kind of building.

Sportsmen and tourists will be interested in two pamphlets just issued by the passenger department, Denver & Rio Grande Railroad. One is a bulletin giving particulars regarding the Colorado and Utah fishing resorts, and the other

# ALDON

CAR and ENGINE

## Replacers

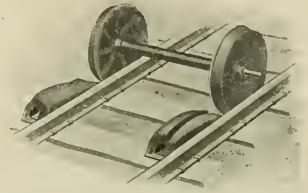

Sure, Safe and Quick Rerailing.  
A Wedge Without Moveable Parts.  
Slope so as to Clear Brakes or Sand Pipes. Rights and Lefts—Steel or Malleable Iron . . .

The **ALDON COMPANY**  
1103 Monadnock Block  
CHICAGO, ILL.

# SKAT

## Unexcelled

FOR

Taking Smut and Grease  
Off Railroad Men

Best Hand Soap Known

SKAT MFG. COMPANY  
791 Park Street, Hartford, Conn.

## Flexible Spout

Vertically in straight line. Also laterally. The latest improvement to

## Poage Water Columns

American Valve and Meter Company

CINCINNATI, OHIO

—SEND FOR CATALOGUE—

# Locomotives, Freight and Passenger Cars

All equipment rebuilt in our Chicago shops, and at Scranton, Pa., in the new "Lackawanna" Shops

## All Kinds of Cars and Engines Ready for Immediate Delivery

RELEASED BY TRUNK LINES

1000—60,000 LBS. CAPACITY REBUILT FLATS AND GONDOLAS  
2000—50,000 LBS. CAPACITY FLATS, BOX AND GONDOLAS  
COACHES, COMBINATION AND BAGGAGE CARS  
FOREIGN SHIPMENTS HAVE PROPER CARE OF  
EXPERIENCED STAFF

Cable Address  
"FITZLUTH"

55 AND 70 TONS CONSOLIDATIONS  
45 AND 50 " 10-WHEELERS  
40 TO 55 " MOGULS  
45 TO 50 " PASSENGERS  
SWITCHERS, FORNEYS AND SHAY ENGINES

**FITZ-HUGH, LUTHER CO., Monadnock Block, CHICAGO**  
141 BROADWAY NEW YORK      CHEMICAL BLDG. ST. LOUIS      80 ST. FRANCIS XAVIER ST. MONTREAL, CAN.      RIALTO BLDG. SAN FRANCISCO

a list of hotels and the various kinds of accommodations obtainable at different points in the Rocky mountain region.

The William C. Baker car heating business has been reorganized and it is now conducted under the name of the William C. Baker Heating and Supply Company, of 143 Liberty street, New York. The officers of the new company are: President and treasurer, L. Baker Andrews-Vaux; J. G. Gadsen, general manager, and M. A. Dean, secretary.

Those of our friends who attend the railroad conventions at Atlantic City this month may not be aware of the difficulties encountered or the obstacles overcome by the early projectors and builders of one of the railroads to that charming seaside resort. The following, taken from the Toronto News, may help to throw some light on at least one of the hardships which our modern method of steam locomotion very nearly brought upon the agricultural interests of that section of the country. It is stated that some years ago, when the route of a railroad to Atlantic City was being surveyed and the men were driving stakes through the premises of an old farmer, he addressed the leader of the gang as follows: "Layin' out another railroad?" "Surveying for one," was the reply. "Goin' threw my barn?" "Don't see how we can avoid it." "Wall, now, mister," said the worthy farmer, "I calkerlate I've got sumthin' tew say 'bout that. I want you tew understand that I've got sumthin' else tew dew besides runnin' out tew open and sht them doors every time a train wants to go through."

During the Master Car Builders' and Master Mechanics' Conventions to be held at Atlanta City, June 13-20, the Niles-Bement-Pound Co. will have an exhibition and in full operation one of their extra heavy 90-inch driving wheel chucking lathes. This will afford an exceptionally good opportunity to observe

this machine at work. Owing to its weight the machine will not be shown on the steel pier. The company have built a special booth, two minutes' walk south from the Pennsylvania Station on New York avenue, near Atlantic avenue, where all visitors are cordially invited to witness a demonstration of the powers of the machine.

President F. D. Underwood of the Erie recently appointed Mr. Angus Sinclair, editor of RAILWAY AND LOCOMOTIVE ENGINEERING, to the position of Inspector of Technical Education for the Erie Railroad. The appointment dates from June 1st. Mr. Sinclair will, in the near future, travel over that road, and will report to the president on this important matter.

The D., L. & W. are having calls for their annual souvenir book, "Mountain and Lake Resorts." The book is beautifully illustrated and is filled with information for those who are planning a summer vacation. The book opens with an entertaining story appropriate to the seasons. Copies can be had upon application to the company.

The Illinois Central Railroad are making improvements in their terminals at East St. Louis. Among them is a round-house of sixteen pits, a turntable, oil-houses, ash pits and ice storehouses, costing, it is said, about \$50,000. St. Louis is now one of the important points of the Illinois Central, and practically all the freight and passenger business of the Missouri district now goes through there.

The Susquehanna & New York Railroad is progressing rapidly with the revision of its line between Ellenton and Short Run. Eight miles of new road will be built and laid with 80-lb. rail, the standard of the company. This work is being done to reduce the present grade in order to handle the heavy and increasing traffic.

### METAL PRESERVATIVE PAINTS AND PRIMER

for locomotives, boilers, stacks, front-ends, gearing, framework, metal roofs, etc.

Tell us your needs.

Metal preservative paints have been our specialty for 22 years.

Paints for all conditions.

THE STANDARD PAINT CO.

Sole Manufacturers

100 William St., New York

CHICAGO

ST. LOUIS

### CONTENTS:

	PAGE.
*Air Brake Department.....	265
Boilers, Horsepower of, Roger Atkinson.....	246
Cars:	
*Flat, 100-ton Capacity.....	254
*Gondola, General Service.....	235
*Side Dump (King-Lawson).....	231
Editorials.....	256
General Correspondence.....	248
General Foremen's Ass'n, Papers Read:	
Cause of Leaky Flues, B. E. Greenwood.....	259
Duties of the Foreman, G. W. Keller.....	237
Machine Tools, L. R. Lazure.....	282
Machine Shop Practice, L. R. Lazure.....	282
Oil vs. Electric Headlights, S. A. Abbott.....	279
Opening Address, C. A. Swan, Jr.....	252
Pooling of Engines, J. C. Wilkinson.....	259
Locomotives:	
*De Glehn Compound 4-4-2 on the P. R. R.....	260
*Simple 4-6-2 for the Southern.....	271
*Simple 4-6-2 for the Norfolk & Western.....	263
Our Correspondence School.....	251
*Patent Office Department.....	233
Personals.....	273
Simple vs. Compound Locomotives.....	276
Shop Appliances.....	245-250-264-280
Tractive Effort of a Motor.....	252
*Tunnel, Driving a.....	242
*Valve and Valve Motion, Development of, Angus Sinclair.....	246

# Railway and Locomotive Engineering

Copyright by Angus Sinclair Co.—1906

A Practical Journal of Railway Motive Power and Rolling Stock

Vol. XIX.

136 Liberty Street, New York, July, 1906

No. 7

## Engulfing a Waterfall.

There are two bridges near the city of St. John, in the Canadian Province of New Brunswick, from which a spectator may, twice in the day, behold the curious spectacle of a waterfall literally drowned out and engulfed, and at such a time he

wagon road to the city, at a height of about 100 ft. above low water mark. The other is a railway bridge of the cantilever type, which was completed in 1885, and is on the line of the Canadian Pacific Railway. This bridge is, with its approaches, 2,260 ft. long, and the river

Railway, with Minto, N. B., the principal town in the fast developing coal fields of Central New Brunswick.

The city of St. John is situated about half way up the Bay of Fundy, which is an arm of the sea lying between New Brunswick and Nova Scotia. The tides



RAILWAY AND ROAD BRIDGES OVER THE ST. JOHN RIVER, NEW BRUNSWICK, CANADA.

might see part of the water which had previously tumbled over the cataract flow steadily back over the rocky ledge and into the gorge through which it had passed on its way to the fall.

The structures shown in our front-piece illustration, span the mouth of the St. John river, and one of them is a suspension bridge which carries the

span is 825 ft. in length. The view we give shows both of these bridges, and it is taken from a pamphlet issued by the New Brunswick Coal & Railway, which is operated in that province by a government commission, with Mr. W. C. Hunter as manager. The railway here referred to is a short one, connecting Norton, N. B., on the Intercolonial

in this bay are probably the most remarkable in the world, and it is due to the great volume of the tidal inflow that the fall on the St. John river is daily blotted out, and what may be called a natural canal lock is formed in the harbor twice in the twenty-four hours.

All rivers which empty into the ocean are more or less affected by the daily

ebb and flow of the tides, and from the earliest times, navigators have had to reckon with these great ocean movements. Tide action is necessarily greatest at the mouth of a river, while its effect diminishes gradually as the stream is traversed towards its source. There is always somewhere, on such a river, a point at which the upward flow of the tide ceases to be felt. A good example of this is afforded by the town of Teddington, about 19 miles above London,



BUILDING THE JETTY AT BANDON, ORE.  
TIDE COMING IN.

on the river Thames. At Teddington the influence of the tide, flowing in from the Nore, becomes practically unappreciable, and the name of the place is said to be derived from that fact. It is in reality the "tide-ending town," and the corruption of these words gives us the modern name of this picturesque Middlesex hamlet.

The tides on the Bay of Fundy are affected by the contour of the coast and by the character of the bed or floor of the bay. The bay itself is an estuary about 140 miles long, having an extreme width of about 45 miles. The contour of the coast lines makes it a gradually narrowing channel. The friction of the water along the indented shore line tends to retard the tidal wave and to concentrate it in the center. The inflowing waters fill all the little bays and raise their levels, and as the tide rushes in, the weight of the water in all these bays exerts a pressure, if one may so say, upon the main body of water, in the center of the channel, and as the water cannot recede in the direction of the Atlantic, the over full bays augment the volume and increase the velocity of the water as it moves toward the head of the narrowing and comparatively shallow channel. The action of the Gulf Stream also exerts a powerful influence on the volume of water which enters the Bay of Fundy. During the winter months, the Gulf Stream, flowing up from the southwest, is more or less deflected away from the land by the cold current edging along down from the Arctic regions, but from March to September the warm waters preponderate, and, flowing more closely along the coast line, are thus able to assist the tidal

wave as it passes along Nova Scotia and turns the corner round Cape Sable and up into the Bay of Fundy.

The tide at the entrance to the bay is about 9 ft. deep. This increases to about 28 or 30 ft. in the neighborhood of St. John, and reaches a height of something over 60 ft. at the highest or what are called the spring tides, in the narrow terminal extremity known as the Bay of Chignecto. The falls at the mouth of the St. John river, to which we have alluded, are about 17 or 20 ft. high, and the average high water tide rises 6 or 8 ft. above the general level of the water in the natural gorge above the fall. Thus it is that twice in the twenty-four hours, for a period of about three-quarters of an hour, ships of moderate tonnage can pass over the completely submerged fall, and up the river, which is regularly navigable to Fredericton, a distance of about 88 miles from St. John.

The high tide in the Bay of Chignecto being, as we have said, about 60 ft., is all the more wonderful from the fact that at the other side of the isthmus, connecting New Brunswick with Nova Scotia, a distance of 14 miles, the waters of Bay Verte only experience a tidal fluctuation of about 4 or 5 ft. The impetuous rush of water, as it sweeps up the Bay of Chignecto, enters the mouth of the shallow Petitcodiac river and gives rise to a tidal wave which follows the windings of that stream and passes up beyond Moncton, where are located the headquarters and the principal shops of the Intercolonial Railway.



TIDE OUT ON THE BEACH NEAR ROCKLAND, ME.

This tidal wave is called "Eager," but more generally the "Bore." Some authorities believe the latter word to be derived from the Icelandic "Bará," a billow raised by the wind. The passage of the bore up the river follows some hours after the high tide has engulfed the falls of St. John and heaped up the waters in Chignecto bay, but the time has been

accurately calculated and notices are daily posted in the hotels at Moncton, giving the hour and minute of its arrival, for the benefit of travelers and sight-seers who desire to look at the wall of water, perhaps a foot in depth, rush up against the river current and all at once alter the level and the direction of the flow.

An interesting comparison between the power of steam and that of the tide was once made by Lord Kelvin. It was quoted by Sir Robert Ball in a lecture before the London Institution in 1889. He said: "Suppose an estuary could be found which had an area of forty acres; then, if a wall could be thrown across the mouth so that the tide could be impounded, the total amount of power that could be yielded by a water-wheel worked by the incessant influx and efflux of the tide would be equal to that yielded by a one hundred H. P. engine, running continuously from one end of the year to the other."

There was a curious railway service in England some years ago on the South Eastern between London and Folkestone. It was called the Tidal Train, and left the metropolis about 51 minutes later each day than its time of departure on the day previous. This arrangement was made so that the train would connect with the steamer leaving Folkestone for Bologne, as the departure of the packet was always dependent upon the tide. The time of this train was carefully tabulated and duly advertised, and though it was an important regular passenger train, it never ran over the

road on the same schedule two days in succession.

The natural wonders which we have here briefly alluded to have been in existence for ages, and thousands of people have seen them and have taken advantage of their operation, chiefly through the instrumentality of that noble work of man, the railway. The regularity of

recurrence which marks the display of natural phenomena carries with it a sublimity which has appealed to the human mind in all ages. In the regular movements of our trains we endeavor, as it

manner in which failures are reported and the methods by which the higher officials handle the statistics based thereon. Attention was especially called to the importance of shopping engines at

age of parts. In conclusion, attention was called to the extremely satisfactory records which many roads are now enjoying with reference to engine failures. A good record being regarded as one which permits a mileage of 10,000 miles per failure, while some roads are to-day operating with less than one failure to 15,000 miles.



THE "BORE" ON THE PETITICODIAC RIVER, MONCTON, N. B.

were, to simulate the orderly processes of nature which are dependent upon the operation of physical laws, and these are not subject to the will of man. In the rhythmic ebb and flow of the tides, and by the effects which they produce upon us all, and our activities and our love of travel, we are irresistibly reminded of the words spoken with authority long ago, which say, "While the earth remaineth, seed time and harvest, and cold and heat, and summer and winter, and day and night shall not cease."

#### Engine Failures.

Mr. M. K. Barnum, assistant to the second vice-president of the C., B. & Q. Railway, recently addressed the engineering students of Purdue University. His subject was "Engine Failures." The importance of the subject was emphasized by a statement to the effect that the proportion of engine failures to mileage is, to some extent, an indication of good or poor management, though the possibility of an epidemic of failure under the best of management was admitted. A broad definition counts as a failure "any delay of any account whatever, chargeable to engines." Another and a much narrower one is a delay of more than five minutes to a passenger train, or of more than ten minutes to a freight train at any one point due to broken, defective, or lost parts of machinery, hot bearings or leaky boilers. A generally accepted definition which lies between these limits makes a failure any defect in an engine or its mechanical operation which causes it to lose time or make stops which would otherwise be unnecessary.

The speaker discussed the effect of engine failures upon the cost of operation, loss of business and the movement of traffic; he then analyzed the causes leading to such failures and described the

proper intervals, large engines in freight service requiring to be shopped after running from 45,000 to 60,000 miles, while smaller engines in lighter service frequently run for 75,000 to 125,000 miles between shopping.

In his discussion of details it was shown that technical failures of engines were often failures of men, the apparatus being in satisfactory condition but delays occurring through inattention or faults on the part of the crew. He said also that the reverse conditions sometimes existed, that through prompt and wise action on the part of the engineer, a technical failure may be actually avoided. Failure of the first class occurred when an engineer brought his engine back to the roundhouse because of an alleged failure of injectors, whereas, in fact, the injectors were in working order but were not properly handled. This, he said, while recorded as an engine failure, was really the failure of a man.

As an illustration of the manner in which a technical failure may sometimes be avoided, a case was cited where an engine within four miles of a terminal broke its piston rod; the cylinder head, piston and rod all being blown clear of the engine. The engineer, knowing that all harm had been done which could be done, held his throttle open and got into the terminal on time, thus avoiding a technical failure, notwithstanding the fact that there was actual and serious break-

#### Cause of Leaky Flues.

The cause of leaky flues was discussed at the General Foremen's Convention at St. Louis by Mr. Charles Paskeen, general foreman of the El Paso & South Western, at Alamogordo, N. M., in a short paper which we here reproduce. He said:

In regard to cause of leaky flues, I will say that in the first place, if the engine comes in the roundhouse the steam is blown down, boiler makers rush into the fire box and start to calk while flue sheet is still hot; the boiler is washed out with cold water and refilled; all is done in a hurry because engines are ordered out within a few hours' notice. Such work brings bad results. I think the best way is that boiler be washed out with warm water and refilled with warm water, and first class workmanship be done. If this method be followed, we would have less leaky flues.

In the second place, it often happens that while engine is in service the regulation of both water and fire is not attended to. One crew while in service



"WHEN THE ICE LEAVES THE LAKE."  
(Courtesy of the Boston & Maine Messenger)

will have leaky flues, while another crew on the same engine will have no trouble whatever.

There is another cause of leaky flues—the use of alkali water. This gives us lots of trouble here in the West. To avoid this here we wash out boiler frequently so as to keep the boiler free

from scale. In the past three years we have reduced our boiler failures 70 per cent. Our company has installed several water softening plants along the line, which helps the boilers a great deal.

We have a number of consolidation engines with 366 flues 15 ft. 1 in. long, and 2 ins. in diameter. These engines have been in service for the past eighteen months, and have been given good attention in the roundhouse as well as while in service. Will say that our average flue sheet only lasts from ten to twelve months.

### British Notes and News.

BY A. F. SINCLAIR.

#### THIRD-CLASS SLEEPERS.

There is a movement on foot in Great Britain in favor of sleeping accommodation for third-class passengers. In this country of class rule, it is nothing unusual, especially in the South of England, to see trains run with enough first-class compartments to give one to each pas-

sleep comfortably, and the cost could easily be recovered by means of a like charge to that paid by the first-class passengers, which many travelers would pay cheerfully. We are progressing.

#### GOOD BUSINESS IN IRELAND.

A railway company in the northeast of Ireland have adopted an ingenious system of extending their passenger business which has something of an American appearance, and may not be new to the readers of this paper, but which is certainly a good deal of a novelty in the British Isles. On the shores of Belfast Loch, an arm of the sea, there are many fine sites suitable for the erection of such houses as would be occupied by Belfast business men. To encourage building the railway company issue free tickets to Belfast for ten years to the occupants of houses built within one mile of any station on their road from Belfast to Larne, a distance of about 20 miles. This looks a little queer on the face of it, but as the tickets are only issued to people in business in Belfast, the tickets per house being strictly limited, it follows that all other members of a family have to pay their way when they travel, and the result is that the company are already reaping an advantage which will be enormously augmented as the free tickets reach their dates of expiry.

#### "CHANGE FOR KHARTOUM."

When, on July 11, 1882, the British fleet bombarded Alexandria, Egypt was a wreck and the Soudan—a fertile and smiling region—the haunt of savages. To-day, Egypt is a peaceful, prosperous country in which life and property are as safe as in most countries in Europe, and the Soudan is on the point of blossoming out as a great agricultural country. Savagery has been suppressed and industry protected, so that where twenty years ago and less no one's life—white or black—was safe, the European tourist now goes for his health. This great change has been effected by means of two admirable agencies—British foreign office administration and railways. These reflections have been inspired by an intimation which has come to hand that a new railway 32 miles in length has been opened to Khartoum, the capital of the Soudan, and will shorten the journey to the sea by about 900 miles. This new railway has its outlet at Suakin on the Red Sea, whence it goes in a northerly direction over a plateau some 3,000 ft. above sea level, then southwest till it joins the Khartoum-Wady Halfa line. The distance in a straight line from Khartoum to Alexandria on

the Mediterranean is about 1,100 miles, and it is a bit over 1,200 miles by the usual route. While the railway from Alexandria is being extended rapidly southward, the missionaries of commerce in the south are also hard at work building the railway northward. The distance from Cape Town to Alexandria is in a straight line about 4,700 miles, so that any railway between the two points would reach well on for 6,000 miles in length. Of that distance about 2,000 miles of road is now in use, but it will take some little time to connect up the two sections.

#### WORKMEN'S TRAINS.

I am not acquainted with the conditions under which workmen's trains are run in other countries, but I question whether they are cheaper anywhere than in Britain. Indeed, the rates charged in many cases are so low as to suggest that if they can be run at a profit there must be a wide margin on ordinary fares which might be curtailed with advantage to the public and to the railway companies. There are two services running out of Glasgow which illustrate the case very clearly. A good many years ago the Singer Sewing Machine Company finding themselves hampered in Bridgeton, Glasgow, erected works  $8\frac{1}{2}$  miles out of the city and about 10 miles from Bridgeton. Since then trains have been running morning and evening with the work people, thousands in number, and the return fare is two pence, or four cents, for about 22 miles, the train starting a mile beyond the old works. Recently a large motor car manufacturing concern finding themselves in the same quandary as the Singer Co. and in the same district, moved double the distance in the same direction, and the fare is also double, that is to say, eight cents for over forty miles. The ordinary return fares are 16 cents and 40 cents, respectively.

#### THE LEITNER-LUCAS LIGHTING SYSTEM.

Electric lighting for railway trains presents some advantages over any other, the most important being perhaps the immunity from fire in case of accident. There have, however, been many obstacles in the way of securing an effective device, and much inventive ingenuity has been displayed in overcoming them. A system which has given results suggesting the arrival of the much sought for apparatus is that bearing the name given above. This apparatus came through a sufficiently severe test recently in a highly satisfactory manner. It was fitted to two passenger cars on the Great Western Railway of England running between London and Penzance in Cornwall, a distance of about 350 miles, and during three months in winter it ran over 25,000 miles. Before the trial began the apparatus was sealed up and during the three months, no re-



"MID QUIET SCENES OF WILDWOOD"  
(Courtesy of the Boston & Maine Messenger)

senger, while the third-class cars are overcrowded. The first-class passenger gets all the consideration, and the third-class man finds the dividends. That has been the rule, and in the matter of sleeping accommodation it has held. For instance, traveling between London and Glasgow, distance 405 miles, a first-class passenger on payment of a dollar and a quarter, can turn into bed at 10 o'clock, or any time up till the time of pulling out at 11.50 P. M., but the third-class passenger can only sit in the corner of a seat, and will consider himself fortunate if no one takes the other corner so that he can get a stretch-out. It is uncomfortable, but better than the American non-sleeper cars, because the seat is long enough to permit an ordinary or a tall man to lie stretched. However, the compartments with two seats usually have more than two passengers, but very seldom more than four, and it has been pointed out that if properly constructed, the ordinary third-class corridor compartment could be made so as to let four

placement of parts, neither oil for lubrication, nor acid for the batteries was added, yet the light gave no trouble, and when the seals were broken at the end of the period, everything was found in such satisfactory condition that the apparatus was at once returned to service. This device is the invention of Mr. Henry Leitner, and is manufactured by the Accumulator Industries, Ltd., of Woking, Surrey.

#### AUTOMATIC COUPLINGS IN BRITAIN.

Seven years ago a Royal Commission, appointed to inquire into the subject, reported that the work of railway shunters was the most dangerous form of employment in the United Kingdom, and that the adoption of the automatic couplings and brakes on both sides would greatly reduce their risk. As the result of that report, an Act of Parliament was passed authorizing the Board of Trade to select, test and enforce the adoption of such appliances by railway companies. I do not know why that Act of Parliament has not been put in force, but it is possible that it may be in the same position as others which get occasionally on the statute book. This question is going to be stirred up in the near future, and if the Act needs amendment it will be carried through. If no amendment is necessary, the Board of Trade will be compelled to enforce the law.

#### RAILWAY AMBULANCE WORK.

During the year 1904 there were killed on British railways 1,185 persons, and during the same period 9,165 people were injured more or less seriously. When accidents occur doctors are not usually on the spot, and unless some one having enough skill to render first aid is present loss of life would not infrequently result. As a consequence, the railway companies give every encouragement to a form of education among railway men which has for its object the imparting of enough knowledge of anatomy and the effects of accidents, epilepsy, drowning, fainting, etc., with their initial remedies as to secure that life shall not be lost for want of a little skill. A society with the name of the St. John Ambulance Association is the active agent in this matter, and their efforts have been so successful that no station or place served by a railway is without some man qualified to render first aid. Train hands, porters, signal men, surface men and others all have qualified men, many of whom have been of great service in cases of accident. The method adopted is for a number of men who desire to obtain instruction to combine, and secure the services of local doctor, many of whom gave their services free. The St. John Association provide the necessary books and bandages. Half a dozen lectures are delivered in the course of the winter, and at the end of their instruc-

tion the class, numbering from 12 (the minimum) up to 30, are examined by an official of the Association, those who pass receiving certificates. The various centers on the railways have afterwards contests in bandaging, stretcher work, etc., and prizes are awarded to the successful classes. On some lines the interest among the men in their 'teens is as keen as in football matches. The most successful team on a railway then represents the men of that line in an annual competition held in London for a silver challenge shield. So expert do the men

The statue stands at the intersection of Broad and Spring Garden streets, and faces the locomotive works. It was presented to the city of Philadelphia by the well-known firm of locomotive builders who still retain the revered name of the founder. Mr. John A. Converse, in giving the bronze memorial to the city, spoke on behalf of his associates. The presentation was made through the Fairmount Park Art Association, and was accepted on behalf of the citizens by Mayor Weaver. The statue was unveiled by Mrs. F. T. Sulley-Darley,



STATUE OF MATTHIAS BALDWIN AT PHILADELPHIA.

come with constant practice on dummy figures that the judges sometimes find great difficulty in arriving at a decision.

#### Statue of Baldwin.

On Saturday, June 2, an interesting ceremony took place in the city of Philadelphia. It was the unveiling of a bronze statue of Matthias Baldwin, the pioneer locomotive builder of this country. The statue, which is the work of Mr. Herbert M. Adams, of New York, was, when being set in place, lifted to its granite pedestal by eight of the oldest of the Baldwin Locomotive Works' employees, headed by Messrs. T. N. Sample and Harry W. Worrell, who were apprentices when Baldwin himself personally superintended the work of engine building.

daughter of the great captain of industry whose name the Quaker City holds in loving and honored memory.

During the ceremony Mr. William P. Hensley, head of the Baldwin Locomotive Works, presided, and introduced the speakers. In his address, Mr. Converse justly applied to Baldwin those noble lines of Milton, "Peace hath her victories no less renowned than war." He went on to say, "The men who have successfully utilized the forces of nature for the convenience and comfort of mankind, or who, by their skill and intelligence, have founded and maintained great industries, are, in this enlightened age, equally entitled to be regarded as heroes. Such was Matthias W. Baldwin. From the humblest beginnings the seed which he planted has grown to large proportions. From a shop of one room

in Lodge alley, the business has grown until it occupies a large area in Philadelphia and vicinity. Its products have penetrated to every civilized country; have promoted the development of re-

a grand army! Transport this army of men to some unsettled territory and immediately you have a city of 100,000 inhabitants."

At the conclusion of the speeches, Mr. George Burnham was introduced to the audience. He is now 80 years old, but is still a member of the firm. In 1835 he entered Baldwin's employ, which was three years after the famous locomotive builder had begun his great work.

The statue is somewhat larger than life size and represents the pioneer manufacturer standing in thoughtful pose. In the right hand he holds a draughtsman's pair of compasses, and in the left is the plan of one of his early locomotives. On the pedestal in front is the one word, "Baldwin," and truly it may be said he fitly bore the name which means, bold winner, and prince friend. On the back of the pedestal the inscription reads,

MATTHIAS WILLIAM BALDWIN.  
MDCXCXV.  
MDCCLXXVI.

Founder of the Baldwin Locomotive Works.  
His Skill in the Mechanic Arts: His Faithful Discharge of the Duties of Citizenship: His Broad Philanthropy and Unfailing Benevolence and His Devotion to All Christian Work Placed Him Foremost Among the Makers of Philadelphia.

#### The Use of Asbestos.

mote nations, and have carried the fame of Philadelphia as a manufacturing city to the farthest regions of the earth. Thousands of skilled artisans have been trained and supported by the works which he founded, and the prestige of American manufactures has been widely extended as the result of his labors."

Mr. Leslie W. Miller, secretary of the Fairmount Park Art Association, when called upon to speak, said: "Matthias W. Baldwin was the perfect type of the makers of Philadelphia. He was, in the truest sense, one of the brightest and best of these fellow-workers. Ingenious, industrious, benevolent, his energies were consecrated without reserve to productive service, and his heart was open as the day to the call of wrong to be redressed, or suffering to be relieved. By the stimulus of his example, as well as by the power of his masterly direction, he added immeasurably to the comfort and contentment of thousands of homes."

In accepting the memorial, the mayor expressed the sentiments of all when he said: "The city of Philadelphia accepts through my hands this magnificent statue of the founder of the great industrial establishment upon which his face in bronze now looks. Baldwin labored to give to the world his first locomotive." "And see," he continued, pointing to the works, "what has come of that beginning—to-day there is across the street an establishment now building 2,500 locomotives a year, 18,000 workmen are employed there—what a magnificent, what

deal of the asbestos used in the United States comes from Canada.

#### Flange Square.

There is a very ingenious tool used in the boiler shop of the Canadian Pacific Railway in Vancouver, B. C., and it has been designed and patented by Mr. A. McFee, the foreman boiler maker at that point. It is a square and is intended for the work of laying out the holes in the flange of a tube sheet or the inside back sheet of a fire box or the round head at the front end.

When one of these sheets has to be renewed the usual way is to place the old and the new sheet on a face plate and lay out each hole by transferring the distance of each from the table, measured on the old sheet, to the new sheet by the use of a rule, a pair of calipers and a scribe. The process is more or less tedious and there is a certain chance of error in the transferring process.

The flange square, as it may be called, is a neat little tool which very much facilitates process just described. It consists of an accurately made square formed out of  $\frac{3}{8}$  in. boiler plate. It has a flange on one side which permits it to stand in a vertical position on the face plate or laying out table. There is a slide which neatly fits the upright arm of the square and on this there is a knob which just fills the old rivet holes in the flange of the sheet which is being measured and different slides with suitable knobs may be used for different sized holes, in various plates, but the principle is the same in each case. The

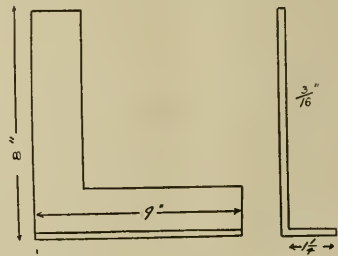

BOILER SHOP FLANGE SQUARE.

notch in the right hand side of the slide permits the knob being placed low down so as to fit into a hole as close to the edge of the flange as need be.

The way this tool is used is to stand it on the face plate and apply it to a tube sheet or any flanged plate which is on the table. The sheet lies with its flange downward, and the new and similar sheet is on top. The knob fits into a



ORDERS FOR A WRECKING TRAIN—HURRY



rivet hole in the original sheet and the slide is then clamped by turning a thumb nut. This firmly holds the slide and when a line is drawn along the upright arm of the square on the new sheet it gives the center line of the new rivet hole.

The vertical center line of each hole is thus accurately scribed on the new sheet, and the horizontal distance from the outer edge of the flange for each hole is taken off in the usual way with a pair of calipers.

#### Lake Champlain & Moriah 2-8-2.

The Baldwin Locomotive Works have recently delivered to the Lake Champlain & Moriah Railroad a Mikado type of locomotive, which has several interesting features. This engine is designed to work on 4 per cent. grades and to pass round 14 degree curves, and for such service the 2-8-2 wheel arrangement is particularly suitable. The rear

wheel base of the engine is 14 ft. 6 ins., and the total wheel base is 29 ft. With the tender, the wheel base measures 52 ft.  $\frac{1}{2}$  in. The weights are: adhesive, 170,230 lbs.; leading truck, 18,800; rear, 15,700 lbs., making a total of 204,730 lbs. With the tender, the total comes up to about 315,000 lbs. The ratio of tractive power to adhesive weight is as 1 is to 3.7.

The boiler is a straight top one, and is 79 ins. in diameter at the smoke box end. It is designed to burn hard coal, and is equipped with a water tube grate. The slides in the bottom of the ashpan hoppers can be operated from the cab. The heating surface is 3,300 sq. ft., with a grate area of 57 sq. ft. The total heating surface is very nearly 58 times the grate area, and we may say, therefore, that for every 58 sq. ft. of heating surface in this boiler, the grate has one sq. ft. of area upon which to burn the hard coal fuel which is used. When it

ability to resist the internal pressure is concerned, and this is, of course, a most important thing, but as the boiler is held to the frames most securely at the smoke box end, and is attached to the frames at the rear by more or less flexible connections, it is built so as to be self-sustaining, that is, it is a structure supported at each end and containing a considerable weight of water, which is capable of motion within the boiler. The internal ring in the smoke box lends additional stiffness at the point where the principal anchorage of boiler to frames is made.

The roof sheet tapers toward the front 4 $\frac{1}{2}$  ins. over a fire box 114 ins. long, and the crown sheet is sloped slightly less, giving approximately a steam and water space of about 22 ins. The minimum water space all round the fire box is 4 ins. at the mud ring. The tubes are 406 in number, 2 ins. in diameter and 14 ft.

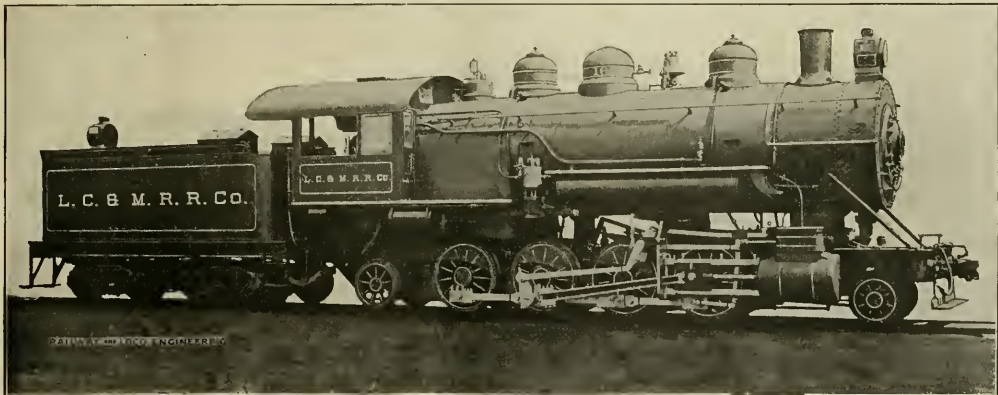

S. Mead, Master Mechanic.

SIMPLE 2-8-2 ENGINE FOR THE L. C. & M.

Baldwin Locomotive Works, Builders.

truck is of the Rushton radial type. The equalizing beam between the drivers and the rear truck transfers weight to the engine frames through coiled springs. The engine is equipped with the Walschaerts valve gear, and the valves, which are of the balanced D slide kind, are driven each from a crosshead located in the same plane as the center line of the steam chest. With this arrangement the combination lever is located inside the guides.

The cylinders are 22x28 ins., and the driving wheels measure 50 ins. diameter. All the wheels are flanged. The calculated tractive effort is 46,000 lbs., and the boiler pressure is 200 lbs. to the square inch. The engine is guaranteed to haul 250 net tons, cars and lading, up a 4 per cent. grade in conjunction with 10 degree curves, or up grades less than 4 per cent. with curves of 14 degrees, the frictional resistance being not more than 15 lbs. per ton. The driving

comes to percentage, the grate area is 0.0172 per cent. of the heating surface, or in other words, if the heating surface of this boiler was represented by one dollar the grate area would, on the same scale of values, be just about equal to one cent and seven mills.

In our illustration there is shown a double row of circumferential rivets round the smoke box just in front of the smoke stack and the saddle casting. These rivets secure a ring 4 $\frac{1}{2}$  ins. wide by 1 $\frac{1}{4}$  ins. thick to the inside of the smoke box. This is used as a stiffener. All boilers are practically tubular boilers, and as a rule have the double circumferential seams and wide laps at each course, not only to resist the bursting pressure of the steam, but to render these stiff structures capable of resisting the strains due to what has been called the galloping motion of the engine, when in service. The double riveting helps to raise the factor of safety as far as the

9 ins. in length. They give a heating surface of 3,117.7 sq. ft., and the fire box gives 182.3 sq. ft.

The tender is supported on steel frames and the tank has a capacity of 5,000 U. S. gallons. The engine is intended for freight or rather pusher service, heavy grades, and altogether is a good example of efficient and heavy railroad motive power. A few of the principal dimensions are as follows:

Valve—Balanced slide.  
Boiler—Type, straight; diameter, 79 ins.; thickness of sheets,  $\frac{3}{8}$  in.; fuel, hard coal; staying, radial.  
Fire Box—Material, steel; length, 114 ins.; width, 25 $\frac{1}{2}$  ins.; depth, front, 72 $\frac{3}{4}$  ins.; back, 61 ins.; thickness of sheets, sides, 5/16 ins.; back,  $\frac{3}{8}$  in.; crown,  $\frac{3}{8}$  in.; tube,  $\frac{1}{2}$  in.  
Tubes—Material, iron wire gauge No. 12.  
Driving Wheels—Journals, all 9 $\frac{1}{2}$ x12 ins.  
Engine Truck Wheels—Front, diameter, 30 ins.; journals, 5 $\frac{1}{2}$ x10 ins.; back, diameter, 36 ins.; journals, 6x10 ins.  
Tender—Wheels, diameter, 33 ins.; journals, 5x9 ins.

### Electrification of the Simplon Tunnel.

Electric traction for the Simplon Tunnel Railway has for many years been the object of the studies and researches of Swiss electro-technical firms. The question of electric traction in the Simplon came to a head when the firm of Brown, Boveri & Co., of Baden, Switzerland, offered to have the whole of the electrical plant ready by the date of the opening of the tunnel and to put this

pole system has been designed so as to allow the locomotive to move in either direction without changing the position of the trolley pole.

The organization of the traffic has been arranged so that at the arrival of a train from Lausanne at the Brigue station, the steam locomotive will be taken off and an electric one put on the train, after which the train will be electrically driven as far as Iselle, where a steam lo-

time occupied on the journey by the passenger trains from Brigue to Iselle will be 20 minutes, and in the reverse direction 30 minutes. The goods trains will take about 40 minutes in each direction.

### Death of a Noted Scientist.

General regret is expressed at the death, by accident, of Professor Curie, the discoverer of the marvelous element, radium. The popular mind, which seldom takes much interest in scientific work, was strongly impressed with the discovery. M. P. Curie was in his forty-seventh year, and was professor of the Municipal School of Physics at the Sorbonne, in France. His discovery followed that of M. Becquerel's accidental discovery of uranium radiation. It was in the effort to find more powerful radiating bodies that Professor Curie discovered radium.

### Electric Engines.

The second of the two electric engines built by the Pennsylvania Railroad at the Juniata shops for experimental purposes has been sent from Altoona to the East Pittsburgh works of the Westinghouse Electric Company, and there equipped with electrical appliances. The first locomotive has not been put in service since being recalled to the shops after the first trials, when defects were discovered. Both locomotives begin a series of experiments early this month. It is reported that the trials will be made by using the electric locomotives

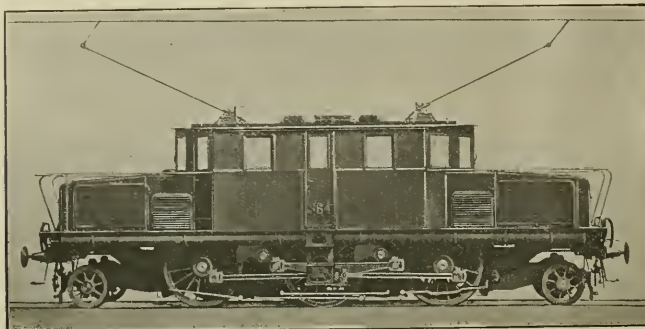

ELECTRIC LOCOMOTIVE FOR THE SIMPLON TUNNEL RAILWAY.

plant at the disposal of the Swiss Federal Railways.

At each of the two portals, at Brigue and Iselle, of the tunnel, there are hydraulic power plants, which have been used to supply power in the construction of the tunnel. With a few alterations and enlargements, it will be possible to use these hydraulic installations for the generation of the current for electric traction.

The contact line or trolley wire, as we would call it, will be suspended in the tunnel on transverse suspension wires, which are fixed on hooks cemented into the walls.

The locomotives were built by Messrs. Brown, Boveri & Co. They have three driving axles and two alternately leading and trailing pairs of wheels, the drivers being connected with two motors, which are placed between the main axles, by means of connecting rods which are balanced by four fan-shaped counter weights, two on each side of the frame. The motors are designed for two speeds, 30 and 40 miles per hour. The draw-bar pull at the slower speed is 6 tons and at the higher speed  $3\frac{1}{2}$  tons. The total weight of the locomotive is 62 tons and the weight on the driving wheels is about 42 tons. The cab, which is of good size, is provided with four doors, two at the side and two at the ends. The end doors permit of access into the train. All the electrical equipment is in the cab with the exception of the rheostats, which are placed in the boxes over the leading and trailing wheels.

Our illustration shows that the trolley

locomotive will again take the place of the electric one.

On the part first to be electrified there are gradients up to 10 per cent. for very short distances. The up gradient on the north side from Brigue to the middle of the tunnel amounts to about 2 per cent., while on the south side, from the middle



NEW YORK CENTRAL ELECTRIC LOCOMOTIVE.

of the tunnel to Iselle, the down gradient amounts to 7 per cent.

The total weight of passenger trains which can be run through the tunnel is 365 tons, and goods trains, 465 tons. The

as "helpers" on the mountain grade, but the final disposition of the locomotives will not be known until the report of the trials has been submitted to the officers of the road.

# General Correspondence.

## New Engine Builder in the Field.

Editor

I send you under separate cover a photograph of a locomotive built by J. F. Looney, age 14 years, stepson of night general foreman, O. K. Oakly, of the Louisville & Nashville. I have seen the construction; though it is crude, it shows wonderful talent in assembling the different parts together, to its present shape, everything being "scraped up from what a boy could get hold of handily.

Yours truly,

J. H. JESSON.

Corbin, Ky.

## Didn't Believe in Book Larnin'.

Editor:

"Uncle George" doesn't believe much in reading in connection with one's work. "Larn' by experience" is his motto, and it is generally conceded that he has lived up to his motto; also that his "experience" during twenty-five years of service has yielded him little of net results in the way of knowledge gained. Uncle George lumps all who learn by reading books or periodicals in one class and calls them "smart Alecks."

Uncle George never allows his fireman to pump his engine as many engineers do. He "pumps her" himself, and he has by long experience reduced the science of using the injector to a very simple proposition. He simply puts on the "gun" and leaves it on until the rainstorm coming back against the cab windows indicates a satisfactory (?) water level, when he shuts it off and "she begins to howl." Of course, the wise fireman knows what's ahead, and would like to keep a bright fire, even if she does howl, but Uncle George, at the first suspicious move, will say, "Don't fight her so hard; don't you see she's full of water!" So the fireman must let his fire burn down to dead coke, in order to accommodate his work to Uncle George's methods. By this time the water is at the bottom of the glass, and Uncle George turns a torrent of water into the boiler, and then looks out serenely over the passing landscape.

Presently he looks around and notes that the gauge pointer is nearer zero than it ought to be, though at the first reach for the injector the fireman promptly took up the fight for steam with a dead fire against the torrent of cold feed water, and he may venture the casual remark that "She's gittin' cold," by way of cheering the flagging spirits of his assistant.

Uncle George has some serious and amusing experiences, and if he profited

by them he would have been a designer of locomotives and equipment long ago. If experience with defective equipment is good schooling (and it is), the extra man who "catches" Uncle George's engine ought to throw up his hat (or cap) and yell. There was a time not long since when Uncle George's signal whistle played a continuous performance for about four months. It never ceased whistling except when the signal line was empty. The only relief from the monotony was when a car discharge

Aleck." This time the whistle was doing its best, and the noise seemed to spur Uncle George to action, and he began to rap the reducing valve, but it did no good, and the "band (whistle) played on." They pulled out, the band still playing, and went into the spur, waiting for their train. Here they found their train was one hour late. Uncle George had given up the battle with the refractory whistle, however. The fireman suggested that he believed the trouble to be in the signal valve,

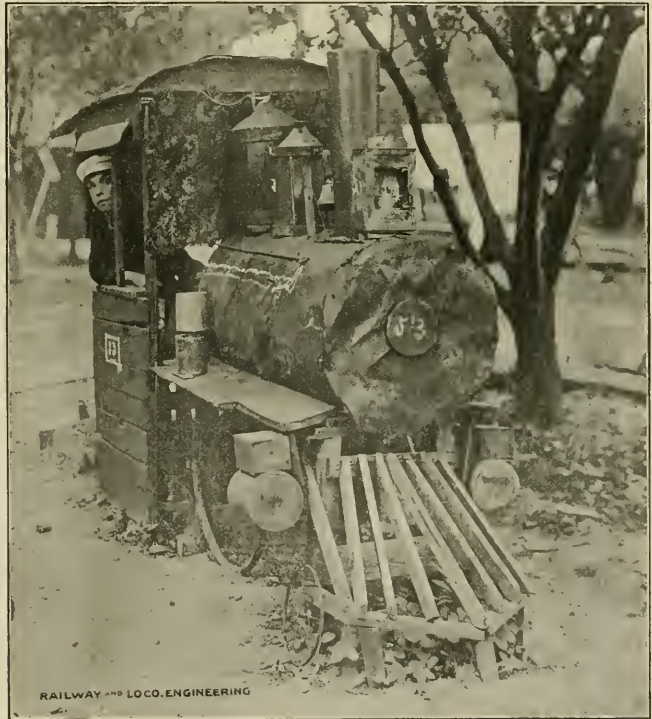

FAST PASSENGER 2-2-0 ON THE BIG STICK & SQUARE DEAL RAILWAY.

valve was opened and the whistle would blow more robustly than usual. Uncle George seemed perfectly happy; never cussed or got mad, like a man of less experimental knowledge might have done.

One day Uncle George caught an extra fireman who read, but who had the good sense to keep in his place and speak only when there was a chance to be helpful, and then gave advice in such a nice, retiring way that Uncle George even could not consider him a "smart

and that if he (Uncle George) would not be afraid to let him try, he thought he could fix it. Having consent, he got down, monkey wrench in hand, and, disconnecting the whistle pipe and removing signal valve nipple, he removed corrosion, dirt, etc., from valve seat and valve. He then connected up the parts, and the noise ceased, the continuous performance of four months' duration ended.

The story might have ended here, but the division superintendent had often

noticed the blowing of the refractory whistle, and happened to be at the station and watched the work of the fireman while Uncle George stood aloof, and saw the results. He reported the matter to the master mechanic, suggesting that an eye be kept on the young man. To-day that fireman is an engineer whose advice is sought by all, and young and old engineers go to him with their knotty problems. Moral: A man may be a good engineer and not read, but not so good but that he would be better by reading. W. W.

Mt. Carmel, Ill.

### Locomotive Discarded for Automobiles. Editor:

One of the last narrow-gauge roads to be abandoned was the Nantucket Central, which is a peculiar line in many respects.



ORIGINAL MOTIVE POWER OF THE  
NANTUCKET CENTRAL.

Being situated on an island, 30 miles from the main land, all repair work on the rolling stock had to be done at home. The road is 8.7 miles in length, but contrary to the usual custom it decreased 20 per cent. during the last few years. The gauge was 3 ft. and the rails weighed in the neighborhood of 40 pounds to the yard.

The motive power consisted of one Baldwin 8-wheeler with straight top boiler and a headlight which rivaled the smoke-box of the boiler in size. The rolling stock, made up of three cars, was one closed passenger, one open passenger and one baggage. During the rush hours the baggage car and one passenger was used, not a very heavy train, but plenty to take over the grades which they had.

On certain days Pullman service was advertised, but a Pullman car never set tail-lights on the coast of Nantucket. Water was taken at one end of the line, and at both ends of the run the engine was switched around the car. The pay roll contained an engineer, conductor and two station masters. Owing to the bad condition of the road it was recently decided to substitute automobiles, and the track has already been pulled up.

J. SWARTZELL.

Chevy Chase, Md.

### Far in Rear of the Band Wagon.

Editor:

"Ye are idle, ye are idle. Go therefore now and work; for there shall no straw be given you, yet shall ye deliver the tale of bricks." Similar expressions adapted from the Pharaonic brick yard were used by the Superintendent of Motive Power when he swooped down on our little shop and roundhouse to learn why the power was down and the expenditures up.

Next day "hurry up" was in the air, men were discharged, others quit, new ones were employed; but to what purpose we were doing A. D. 1906 work with A. D. 1876 tools. Then 18x22 was the largest engine and three through freights in one day caused a boom in real estate, but now a varied assortment of consolidations, moguls and ten wheelers are biting each other's heels on the cinder pit track, and an ever-hungry dispatcher is calling for engines faster than they can be made ready.

Had the S. M. P. seen eight men burning an hour of daylight laboriously lifting up the 7707's front end casting by hand, or observed a whole day spent in wheeling her by the ancient jack and block process—then maybe a Triplex would have been forthcoming and some form of a drop pit built.

The spectacle of rod and eccentric keys being laboriously planed on a 36x96 inch planer while a curved legged, patriarchal shaper stood uselessly by, might have encouraged him to step over to the big back geared drill where a youth, badgered by a "me next gang," was patiently drilling a 3/16 in. hole with a slow running flat drill. A new shaper and a \$30.00 pin drill would help.

Our S. M. P., now less ready to veto requisitions, might, if he waited long enough, have seen a slim spindled lathe nibbling for four hours on a driving box, but the stock pile with its blanket sizes of rod bushings, packing ring drums and eccentric straps should certainly have stunned him. Two inches of stock on a rod bushing wastes time and brass, and it makes slim spindle chatter for several hours to cut 2½ inches from an eccentric strap. Well, our Superintendent went East on the night train, "the tumult and the shouting has died," the work still drags. But are the men to blame?

A. KNUT SPLITTER.

### Why An Engine Moves.

Editor:

The case of a locomotive driver rolling along the rail is very different from a stationary engine flywheel. The whole locomotive moves forward on the track, so axle is not the true axis of rotation, when referred to the rail. In the case of the locomotive driver the velocity of center of axle is equal to the forward velocity of the engine. If

we take a point on the wheel near the rail, the point moves very slowly, relatively to the rail, and the point of contact of wheel with rail has no motion at all. As the point of contact of wheel and rail is the only point on wheel which has no motion it follows that for any given instant the wheel is revolving about this point of contact. When wheel turns a little, this center of rotation moves to the new point of contact and is fixed only for the instant in question. This center, which the wheel revolves about, for any instant is known in mechanics as the "Instantaneous Center" and for a rolling wheel is always the point of contact of wheel and ground or rail. When the engine slips we no longer have rolling contact and driver revolves about center of axle exactly like a stationary engine flywheel.

To return to the forces acting at crank pin *C*, we have force *CK* and the perpendicular distance of its line of action from the instantaneous center *B* is *BN*, which is called the lever arm of the force. Thus the force *CK*, which equals the piston thrust *AD*, acts with the lever arm *BN* and tries to rotate wheel backward. We have the small force *CH* with the very short lever arm *CN* tending to rotate the wheel forward, but its effect is small compared with the tendency to rotate the wheel backward, and if these were the only forces acting the locomotive would move backward. Action and reaction are equal and opposite, and while we have a force *AD* pushing piston back,



LARGE HEADLIGHT AND ENGINE FORMERLY ON THE N. C.

most of which opposes the forward motion of the locomotive, we must have a force equal to *AD* tending to push front of cylinder ahead. As the cylinders are bolted to the frames, this force on front cylinder-head moves cylinders and frames forward and brings back pedestal jaws up against driving boxes. Thus the force *OL*, which is equal to *CK*, acts at center of wheel to turn wheel forward and has a lever arm *OB*. Now the backward and forward forces are equal, but the leverage of the forward force exceeds that of the backward force by the amount *ON*. Thus the effective lever arm *ON*, acted on by the

force *OL*, which, together with the small force *CH* and its lever arm *CN*, actually turn wheel forward in spite of the opposing force *CK*. Now the effective lever arm increases as crank moves toward lower quarter, and is greatest at the quarter, but at this point we have entirely lost the lever arm of the small helping force *CH*. Thus the position of crank for greatest turning effort is before the quarter and is somewhere between the lower forward eighth and the quarter. This maximum effective leverage, together with the fact, that, for this position of the crank, the cut off has not occurred, when starting, so that we have a very large cylinder pressure, and all this gives the greatest turning effort at this crank position, and if this exceeds the frictional resistance the drivers slip. It seems to me this is the reason why a locomotive is apt to slip in this position and not because main rod exerts a lifting action on the drivers.

Now, when crank and connecting rod are as shown, dotted, and pin is at *P*, on the upper back eighth; if we assume

lever arm with pin at *C* was *ON*, while with pin at *P* the effective lever arm was *OW*, which is equal to *ON*, and with equal steam pressures on piston the driving forces are equal. One might very naturally ask if effective leverages are equal and driving forces are equal, why does not engine start to slip with crank on upper back eighth as often as it does on lower forward eighth? Suppose for the moment we neglect the vertical forces in both cases, as rotative effort is the same for both positions of pin and friction on rail is the same, the engine would be just as apt to slip in one position as the other. If this rotative effort is just about to cause driver to slip when the crank pin is at *C*, the small assisting force *CH*, with the lever arm *CN*, comes in, and the total rotative effort being more than the friction can stand the engine slips. On the other hand, with pin at *P*, and rotative effort just about to slip the driver, the vertical force *PS*, with the lever arm *PW*, opposes rotation of wheel, thus the total rotative effort is decreased and friction is able to

result. I would like to state what I have found to be the quickest, easiest, and most satisfactory way to make a temporary repair, and get moving again.

Take the small steel bar, put it in the fire, heat one end and bend it over about two inches at right angle to the bar, then cool it off, put the turned over end in the hole where the stub came out,

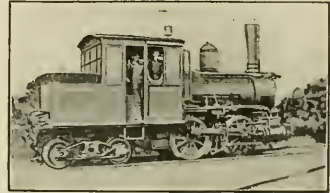

FORMER NEW YORK "L" PUFFER.

then pull the bar forward as a lever and it will draw the gland back to its place. Tie the bar to something handy with the bell rope and you will have no more trouble from that source. L. C. M.

Houston, Tex.

**Electric Road Takes to Steam.**

Editor:

New Yorkers and especially the men who ran the little engines on the elevated railway, may be interested in the enclosed photographs of No. 169. She is at present running from Rosslyn to Great Falls, Va., and is doing rather interesting work. Last fall an electric road was built to operate from Georgetown, D. C., to Great Falls, but almost as soon as opened difficulty was experienced owing to the lack of power which made it a hard job to get the cars over the grades. A short while ago it was suggested that perhaps steam would run the road more successfully, and accordingly the company purchased one of the Manhattan Elevated R. R.'s Forney locomotives, No. 169, and



CREW OF ENGINE NO. 169.

two coaches, 46 and 152. These are so satisfactory that the road has ordered another locomotive and two more cars.

No. 169 is well kept up and looks in good condition. The men all like her and say they would rather have her than any electric car built. We thus have an electric road converted, partially at least, into a steam railway.

HUGH G. BOUTELL.

Washington, D. C.

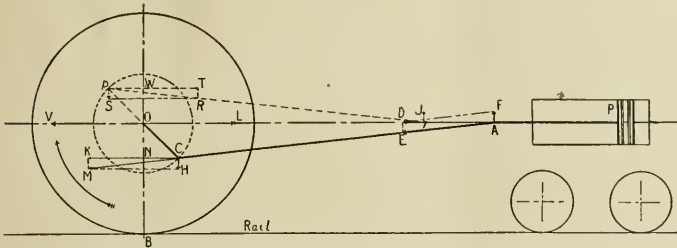

DIAGRAM SHOWING FORCES ACTING A DRIVING WHEEL.

the locomotive to have tail rods, the pressure forcing piston ahead is equal to the pressure forcing it back when crank pin was at *C*. This means that the horizontal force *PT* is equal to the horizontal force *CK*, but the vertical force *PS* is not exactly equal to force *CH*. However, the vertical force *PS* is equal to the upward thrust *II* on the upper guide, exactly as before. Now we have the connecting rod exerting the force which drives the engine forward, namely, *PT*, with a lever arm *BW*. This time the reaction of the steam pushes back cylinder head backward, this pushes frame back and brings forward pedestal jaw against driving box. Thus the back cylinder head furnishes the retarding force *OV*, which is equal to the forward force *PT*, but has a lever arm *OB*. Thus the lever arm of the forward force exceeds that of the retarding force by the amount *OW*, so the locomotive still goes ahead. The vertical force *PS* having a lever arm *PW*, now acts to the left of the instantaneous center, and as a result retards the rotation of wheel, just as when crank pin was at *C* the vertical force assisted to turn the wheel forward.

Now it will be seen that the effective

hold wheel to rail and slipping does not occur.

Let me say that when crank pin gets to the lower back eighth, engine is apt to slip due to crank on the other side, with right side leading, if we are considering the right side of engine. Practical men have observed that a locomotive is apt to slip just where theory indicates that it should, so theory and practice seem to agree uncommonly well in regard to the slipping of the locomotive.

Boston, Mass.

**Repairs for Broken Gland Stud.**

Editor:

It often happens that a stud on the piston or valve stem gland breaks, and then there is some figuring done to find some way to fasten that gland so it will stay till we get in, especially where the stud is broken off with the cylinder head and can't back it out, and with some makes of engines this is no easy matter; unless there can be some arrangement found to clamp or prop it with the tools and material available the condition becomes serious, and cases have been known where a disconnect has been the

### Cost of Setting Tires.

Editor:

In the May issue of RAILWAY AND LOCOMOTIVE ENGINEERING, I noticed an article on tire removal and tire setting, doing a set of 6 tires for \$9.40, using gasoline; we do the same work for \$3.65, as follows:

Taking off 6 tires—  
 2 hrs. for 1 helper at 2½ cents. .45 cents.  
 2 hrs. for 1 helper at 15 cents. .30 cents.  
 Putting on 6 tires—  
 4 hrs. for 1 machinist at 35 cents. \$1.40  
 4 hrs. for 1 helper at 2½ cents. .90  
 30 gallons of fuel oil at 2 cents per  
 gallon ..... .60

\$3.65

M. McCOMAS.

General Foreman, M., K. & T. Ry.  
 Denison, Texas.

### "Hold Fast" Equalizer Stand.

Editor:

I am enclosing sketch of an equalizer stand which General Foreman J. E.

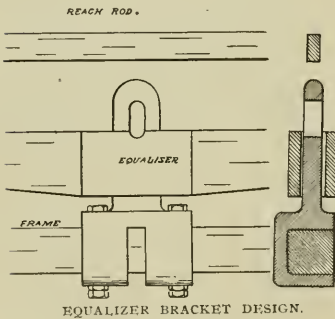

EQUALIZER BRACKET DESIGN.

Burke, of our St. L. & S. F. shops at Monett, Mo., is having applied to our 300 class 2-6-0 engines. The reach rod is placed close to fire box over the equalizer and stand. In case the bolts in the main equalizer stand break, the stand and equalizer always rises up and clamps the reach rod, rendering the use of the reverse lever impossible. While this may not cause a complete engine failure, it will cause delay which is generally considered as an engine failure. We have had several engine failures due to broken equalizer stand bolts which led to this improvement. With this stand, you will see that in case the bolts do break, the two hooks which pass around one side and under the frame will hold the stand in place, thereby preventing even a moment's delay.

Hoping this may be of use to some of the many readers of RAILWAY AND LOCOMOTIVE ENGINEERING who are interested, particularly in prevention of engine failures.

JOHN F. LONG.

Gang Foreman, Frisco System.  
 Monett, Mo.

### Filling Engine While Being Towed.

Editor:

In answer to Mr. E. B. Thrall, whose letter appeared in your May number. With regard to filling boilers of dead engines by towing I would like to say that he never would get one filled should he plug the exhaust nozzles, as he suggests. The correct procedure is to fasten shut the steam chest relief valve, cylinder cocks closed, whistle valve tied shut, injector frost or heater cocks shut, water valve to injectors open, steam rams open, when by towing engine with reverse lever in direction which engine is towed and throttle valve open a partial vacuum is created in the boiler by reason of the pistons pumping the air therefrom, which causes the water in the tank to flow into boiler by reason of atmospheric pressure. An empty battleship can be filled in this way in 30 minutes.

W. W. DONALDSON.

Charleston, Ill.

### Filling While Being Towed.

Editor:

In the June issue of RAILWAY AND LOCOMOTIVE ENGINEERING, page 251, in regard to filling a boiler while being towed, Mr. R. L. Leavitt asks some questions, and I will try to explain the operation.

First see that tank has water in it; then wind the fireman's overalls around the suction valve; stop up the exhaust nozzles. The cylinders now are converted into pumps. Open throttle, also injector throttles, close cylinder cocks; have reverse lever in normal position the same as when drifting. In this condition when engine is towed the pistons form a strong vacuum in the boiler, and it will be surprising how quickly the boiler will fill with water.

E. B. THRALL.

Plattsmouth, Neb.

### Cleaning Flues.

In the Montreal shops of the Canadian Pacific Railway there was recently erected a machine for cleaning flues, which is said to be giving much satisfaction. The apparatus consists of a tank long enough and large enough to hold about 500 flues. A steel framing provided with sprocket wheels causes the flues to revolve by the action of a chain. The scale is by this means broken off, and the soot is loosened and washed from the interior of the tubes by water flowing through the tank.

Newfoundland seals are not fur-bearing, but are killed in large numbers for their skins and fat. The skins are transformed into patent leather and "kid" gloves; while the fat makes delicious soup.

### Mileage of the Pennsylvania.

We have received a copy of the Record of Transportation Lines owned and operated by and associated in interest with the Pennsylvania Railroad. The title of the pamphlet, which we have just quoted, brings up the question often asked with reference to the relation of the Pennsylvania Railroad to the Pennsylvania Company, and also the meaning of the term, Lines West.

As a matter of fact, the Pennsylvania Railroad Company is a corporation of the State of Pennsylvania, which owns, leases and operates certain of the lines in the Pennsylvania Railroad System East of Pittsburgh and Erie. The Pennsylvania Company is a corporation of the State of Pennsylvania, which operates certain of the lines owned in the interest of the Pennsylvania Railroad Company west of Pittsburgh. The term Pennsylvania Lines West of Pittsburgh and Erie is one adopted for convenience in operating matters, and includes not only the lines operated by the Pennsylvania Company, but also those operated by the Pittsburgh, Cincinnati, Chicago & St. Louis Railway Company.

The Record of Transportation Lines has been compiled in the office of the Chief Engineer of Maintenance of Way of the Pennsylvania Railroad in Philadelphia, and consists of a very complete tabulation of the mileage, both main and siding, owned by the road and all its divisions and branches. A very interesting recapitulation of the Pennsylvania by divisions is given on pages 26 and 27. The total mileage made up by adding the trackage of its four lines and sidings, amounts to 11,707 miles, and during the year 1905 there were 309 miles added. The grand total for lines East and West amounts to 22,365¼ miles.

The railroads listed under the term Pennsylvania Lines West of Pittsburgh on pages 32 to 37 inclusive, embrace the lines operated directly from the general offices located in Pittsburgh, Pa., while the several railroads shown on pages 38 to 42 are operated under separate organizations, although they are controlled by the Pennsylvania Company or the Pittsburgh, Cincinnati, Chicago & St. Louis Railway Company through ownership of capital stock.

### Railways in Nova Scotia.

From a government report on public works in Nova Scotia it appears that the aggregate railway mileage in the Province is 1,174 miles. There were 48 new iron bridges built in 1905 and 115 others are under construction. The total amount expended on roadways and bridges was over \$250,000.

### Historic Locomotive.

By the courtesy of the Pennsylvania Lines, and especially as a result of the interest shown by Mr. D. F. Crawford, general superintendent of motive power, Purdue University, at Lafayette, Ind., has been able to add a machine of more than passing interest to its collection of historic locomotives. This latest acquisition, which is the sixth locomotive

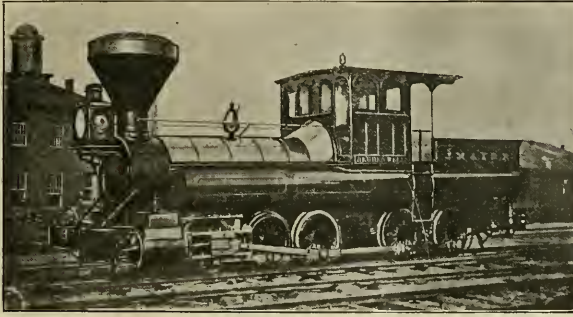

FIG. 1. TANK LOCOMOTIVE "REUBEN WELLS," FORMERLY ON J. M. & I. R. R.

to take its place in the Purdue museum, is the "Reuben Wells," which was built in 1868 by what was then the Jeffersonville, Madison & Indianapolis Railway, for use on the Madison incline. Its appearance when new is shown in Fig. 1. It was remodeled somewhat recently, the rear end of the frame having been cut off, the number of axles reduced from five to four, and a saddle tank placed over the boiler. The engine as it now appears is shown in Fig. 2.

This engine has been used in the immediate vicinity of the city of Madison, Ind. Located upon the Ohio river and surrounded on the east, west and north by hills rising to a height of over 400 ft., Madison was easily accessible from the water, but the steep hills on all of the roads leading away from the town made it difficult to distribute merchandise to the interior. After a long period of discussion the construction of a railroad was finally undertaken. The initial portion of this road was finished in 1841. The portion then completed consisted of a mile and a quarter of track rising almost uniformly at the rate of 310 ft. to the mile, or with a grade of 5.89 per cent. This incline was designed, and for many years was operated as a rack and pinion road, the first locomotive having been built by the Baldwin Locomotive Works and sent from Philadelphia to Madison by water. Some years later, when Mr. Reuben Wells was master mechanic of the J. M. & I. Railroad, he became convinced that by the use of a properly designed locomotive the rack and pinion might be dispensed with. He designed and built the locomotive which has now been presented to Purdue Uni-

versity. This engine, when put to work, and with plain wheels, performed a service which had previously involved the use of gears. It was in fact a most excellent adaptation of the means to an end, the significance of which becomes greater when it is remembered that it was put in service in 1868.

A matter which lends interest to the giving of this locomotive to Purdue Uni-

to begin piling up money in order to have a balance to her credit when next going to the shop. That idea was practically the keynote of Mr. J. E. Goodman's address to the Northern Railway Club a short time ago. He is one of the master mechanics on the N. P., and, in briefly outlining the method of dealing with locomotive repairs on his road, said:

Approximately, locomotive repairs amount to about 17¼ per cent. of the total cost of locomotive maintenance per engine mile, the greatest item being fuel, which amounts to about 48 per cent. of the total cost. Locomotive maintenance includes cost of round-house labor, repairs, coal, waste, oil and supplies, and it also includes the pay of the engine crew. The new method, which some roads have adopted, consists of an allowance per engine mile for repairs, and this allowance ranges, usually, from about 2¼ cents per mile for the lightest power to 7 or 8 cents per mile for the heaviest engines, and comprises running and general repairs. The figures for the different allowances are based on the average cost of repairs, covering a long period, for the different classes of power.

Each engine should receive credit at the ruling scrap price for every pound of material removed in the course of repairs. Damage by accident forms a separate item and should be shown in a column by itself. Engine failures which are brought about by weakness of parts,

iversity is found in the fact that its designer and builder, Mr. Reuben Wells, now superintendent of the Rogers Works of the American Locomotive Company, was one of the five trustees of Purdue University from 1875 to 1881, a period during which the first steps were taken in the development of the present engineering courses of that in-

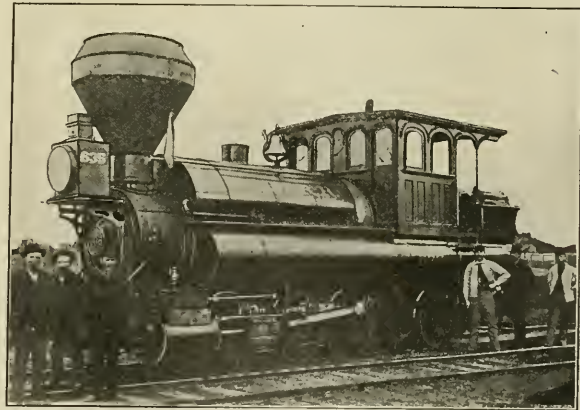

FIG. 2. OLD WOOD-BURNING TANK ENGINE, NO. 635, J. M. & I. R. R.

stitution. When Professor Goss was appointed to the head of the engineering department at Purdue, it was Mr. Wells, representing the trustees, who first gave him welcome.

#### Cost Per Mile Run.

Suppose an engine comes out of the shop free of debt, that engine has got

improper repairs, lack of attention by the engineer and fireman should be considered as running repairs.

In order to make the system of mileage allowance a success, all officials from the head of the department down to the foreman in charge of the work must display an active interest in the record of each engine and the performance

sheets must be studied carefully by all concerned, among whom, of course, are the engineer and fireman. These sheets show how the allowance per mile stands at any particular time, the mileage made, the material and the labor put on each machine. Under this system each month the master mechanic is given an elaborate statement showing the financial status of each engine on his division, by which he is shown the actual cost of running repairs. A copy of this report is sent to the road foreman of engines, the roundhouse foreman, and a condensed bulletin containing similar information is issued for the benefit of the engine crew.

If an engine runs at something less per mile than the rate fixed for the class to which it belongs, it is adding to its credit balance or is piling up money, and this amount, we may say, the engine has ready to spend when it goes into the shop for repairs. For example, an engine may have gained \$1,200. When that engine comes into the back shop, the superintendent will probably try to do the work for that amount. It is, however, not economy to turn the engine out in any way below par. It is far cheaper in the long run to put an engine into thoroughly efficient condition, even if it comes out of the shop \$400 or more in debt.

If an engine comes out of the shop in a leaky or otherwise defective condition, expense begins piling up at once, but if it has been put in a proper and efficient state before being turned out it would soon get out of debt and begin, as Mr. Goodman phrases it, piling up money. It is roundhouse repairs that are costly because of overtime, often want of facilities for doing work, hurry

#### Flush Floor Drop Bottom Car.

An interesting form of what is called the flush floor drop bottom gondola construction is to be seen by any intelligent observer who looks at one of the

ment and the sides are about 5 ft. 10 ins. high.

In the first place there are two center sills, each made of  $\frac{3}{4}$  in. steel plate, stiffened on their lower edges by

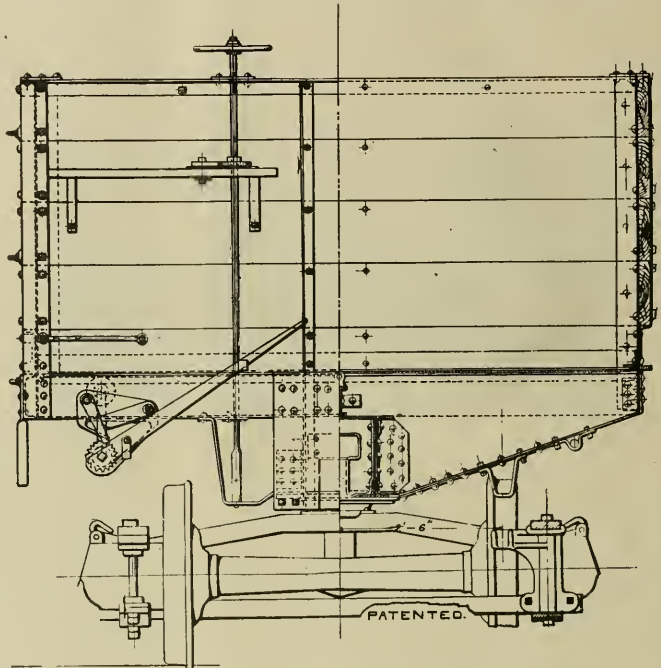

END ELEVATION AND SECTION, RALSTON CAR.

cars recently turned out by the Ralston Steel Car Company of East Columbus, Ohio, for the Toledo & Ohio Central. At the works this is known as the H-5

$3\frac{1}{2} \times 3\frac{1}{2}$  in. angles, a  $\frac{3}{4}$  in. cover plate is laid along the top of these center sills which are also edged with angles. The part of these sills below the two center panels is 30 ins. deep, and from the points where needle beams in ordinary cars usually appear the center sills taper up to a depth of  $13\frac{1}{2}$  ins., and from the body bolsters to the end sills they are carried along at that depth.

The body bolsters are practically box girders with level tops about 26 ins. wide and their under sides, while level beyond the center plates, taper up to the car sides. The ends of these bolsters are about 10 ins. deep. The truck side bearings are 5 ft. apart, thus giving strong and substantial support for the floor of the car. The vertical plates of the center sills are spaced about 16 ins. apart, and on top of these, at intervals of about 5 ft., are a series of cross bearers made of steel channels which stand on the center sills at right angles to the length of the sills and with webs vertical. There are five of these cross bearers and with the two body bolsters and the two end sills make a steel skeleton lying upon and securely fastened



SIDE DUMP CAR, WITH ALL DROP DOORS FULL OPEN.

which may result in doing the same piece of work more than once, and the loss of engine mileage at a busy time. The economy of a thorough shop overhauling is beyond question.

pattern, but to the railroad world it is an improved type of car in which simplicity, strength and utility have been very happily combined. The car is 40 ft. long by 9 ft. 3 ins. inside measure-



to the heavy center sills like cross-arms on a telegraph pole.

At the points where the center sills have their greatest depth or, as we have said, where needle beams usually appear, there are wide diagonal plate braces extending from the center sills to be cross bearers, and these not only help to support the car floor but they eliminate any racking tendency which might otherwise exist by reason of the cross bearers resting on top of the center sills. The unsupported center of the car is thus seen to be strongly built with its deep center sills and the diagonally braced cross bearers, so that there can be no sag in the level floor-line of the car.

The side stakes of this car, if we may so call them, are not dropped into pockets on the side sills, for there are no side sills in the ordinary sense of the word. What is there is a light steel channel bar to which the cross bearers are attached. These form the outside edge of the framing, but do not take the place of side sills as generally applied. The stakes are T-steel bars with flanges outside, the webs of which, at their lower ends, are riveted to the vertical webs of the side bearers and the flanges of the stakes are secured by angles, so that it may be said that the side bearer, with two stakes, one at each end, make practically one cross member.

From this description it is tolerably clear that the Ralston car has a strongly made steel skeleton, and one might liken it in a way to the form of construction adopted by builders of modern steel ships. The center sills form the keel of

The stakes of the car having their flat flanges outward, making the sides of the car flush, and offer a convenient method of applying the planks along the outside. The floor practically consists of the spaces between the cross members of the car, and as there are eight of these, there are sixteen doors in all, and they open

their ends, and one long ratchet lever. Each lever has a pawl for giving motion to the shaft, and the second ratchet wheel and pawl is for the purpose of preventing the shaft from rotating backward while a new grip is being taken, and it also acts as a lock when the doors are closed, and prevents any chance of a pre-



RALSTON DUMP CAR AS A GENERAL SERVICE GONDOLA.

through a distance of 2 ft. 3 ins. The doors over the trucks open as wide as the others, and the whole lot come down to the level of the top of the axle boxes. In order to get as great an angle of slope as possible, and to do away with any dead area down the center of the floor, there is a 5-in. I-beam placed on top of the horizontal plate of the center sills. This serves the double purpose of supporting the hinges of the doors and raising them up so that when the doors are open they clear the center sills.

The door operating mechanism is a very ingenious arrangement. The doors

are mature or accidental opening of the doors. When the doors are shut up, the cranks are all on the dead center, and there is, therefore, no strain on the locking pawl, which is there, however, to make assurance doubly sure. The shafts are divided in the center so that each one of the levers controls four doors. A quarter of the load can be dumped on one side, or all on one side can be dumped, or both sides may be made to let go at the same time. The car dumps 90 per cent. of its load when all the doors are open, and no shoveling is required. As occasion arises, the car can be used as a side dump or as a general service gondola, and in either case it is strong, simple and efficient.

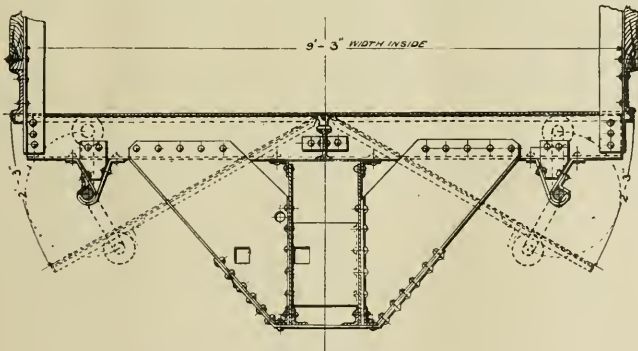

SECTION AT CROSSBEARER  
CENTER SILLS AND CROSSBEARER BRACES, RALSTON CAR.

this steel freighter, and the body bolsters and cross bearers, with the upright stakes at their ends on the end sills with the corner posts, correspond to the frames of the ship, which are what landsmen usually call ribs. In this case the word "gondola," which is correctly applied to the car, has perhaps an additional maritime significance which is not inappropriate.

open by gravity, but are closed by the movement of a crank shaft. The line of the shaft is attached to the transverse members and the cranks pass under the doors. Each crank has two rollers which bear against the under side of the door, so that when the crank shaft is revolved the door can be moved with comparatively little effort. The crank shafts have each two ratchet wheels on

The average result obtained by a test of sixteen samples of one inch Falls Hollow Staybolt iron made with a 3/16 hole in the center were very satisfactory indeed. The test was made at the Baldwin Locomotive Works. The etching test shows the iron to be slab piled.

We are informed that two carloads of Falls Hollow Staybolt Iron Bars were recently shipped to the Mitsu Bishi Dockyard and Engine Works, Japan; also several tons of double refined charcoal iron hollow bars were consigned to the Prussian State Railway Department. This indicates that Falls Hollow Iron is used by foreign railways, and the company states that they are shipping material to Australia, New Zealand, Norway, Prussia, Germany, Japan, China, Korea, Brazil, Peru, Cuba, Porto Rico, and other foreign countries. The works and offices of this company are situated at Cuyahoga Falls, Ohio.

The reward of a thing well done is to have done it.—Emerson.

# Railway and Locomotive Engineering

A Practical Journal of Railway Motive Power and Rolling Stock.

Published Monthly by

**ANGUS SINCLAIR CO.,**

136 Liberty Street, New York.

Telephone, 984 Cortlandt.

Cable address, "Loceng," N. Y.  
Glasgow, "Locauto."

## Business Department:

**ANGUS SINCLAIR, President.**  
**FRED M. NELLIS, Vice-President.**  
**JAMES R. PATERSON, Sec'y and Treas.**

## Editorial Department:

**ANGUS SINCLAIR, Editor.**  
**GEO. S. HODGINS, Associate Editor.**  
**JAMES KENNEDY, Associate Editor.**  
**J. P. KELLY,**

## Advertising Department:

**Eastern Representative, S. I. CARPENTER, 170 Summer St., Boston, Mass.**

## British Representative:

**THE LOCOMOTIVE PUBLISHING CO., Ltd., Amen Corner, Paternoster Row, London, E. C.**

## Glasgow Representative:

**A. F. SINCLAIR, 15 Manor Road, Bellahouston, Glasgow.**

## SUBSCRIPTION PRICE.

\$2.00 per year, \$1.00 for six months, postage paid in the United States, Canada and Mexico. For other parts of the world, \$2.50 or ten shillings. Single copies, 50 cents. Remit by Express Money Order, Draft, Post Office Order or Registered Letter. Mailing address can be changed as often as necessary—always give old and new address, and if you subscribe in a club, state who got it up. Please give prompt notice when your paper fails to reach you properly.

Entered at Post Office, New York, as Second-class mail matter.

Copyright by Angus Sinclair Co., 1906.

For Sale by Newsdealers Everywhere.

## Light Losses from a Headlight.

The reflector of a locomotive headlight is a very wonderful thing. It is made of copper, on the inside of which is deposited a thin layer of silver, and this bright surface is then polished until it shines like quicksilver. The usual source of light used in a locomotive headlight is an oil lamp, and it is probable that this lamp with its argand burner and deflecting button, has brought the oil flame up to its maximum degree of brilliance, and yet even when backed by the efficient reflector, as it is when new and bright, it makes but a poor search in the darkness ahead of a fast train.

The silvered reflector which completely envelops the lamp is the most costly part of the headlight. This shining metal cave, toward the end of which the lamp is placed, is called a parabolic reflector because the curve from which it is derived is known in geometry as a parabola. This is a plane curve having some curious properties. As far as the reflector is concerned, the parabola would become at once apparent if the locomotive headlight was sawed in two along its axis.

The parabola belongs to that family of plane curves known as the conic sec-

tions of which the circle the ellipse and the hyperbola, are the other members. These curves are called conic sections because they are formed when a cone is cut by a plane. The circle is formed when a cone is cut square across by a plane parallel to its base. The ellipse is formed if the cutting plane is tilted at a slight angle. The parabola makes its appearance when the cutting plane is parallel to one of the cone's edges, and the hyperbola, when the cutting plane is parallel to the axis of the cone.

To get a clearer idea of how the parabola is made, suppose the cone to be represented by the letter A, and that it is cut through by a line parallel to one of the legs, just as a person, pen in hand, might cross out the letter from a printed page with one stroke, sloping from right to left. The curve formed by cutting a cone with a plane as the sloping line cut across the letter, is the parabola.

This curve when used as it is in the locomotive headlight, has the curious property of reflecting light in rays parallel to the axis of the reflector. There is, however, one condition which must be fulfilled in order to secure this kind of reflection, and this is, that the source of light shall be at a certain point on the axis, called the focus of the curve.

The parabolic reflector is capable of throwing the greater part of the light, which reaches its surface in one direction, total reflection being here impossible, the bulk of the light nevertheless leaves the headlight as a cylindrical beam the full diameter of the circular mouth of the reflector. The direct light from the lamp is the diverging rays which would come through the glass if the reflector was removed and the lamp held in its usual place inside the case. This direct light comes out in the form of a cone, part of which falls upon the track close in front of the pilot, and the rest goes off uselessly to the right and left and upward.

As the reflector completely envelops the lamp, it receives what one might say on a rough and ready estimate about  $\frac{3}{4}$  of all the light coming from the flame, and nearly all of this it throws ahead in a beam parallel to the track. Of the direct light, which, as we have supposed, is about  $\frac{1}{4}$  of the total, perhaps  $\frac{3}{4}$  is thrown above and on each side, so that only about  $\frac{1}{8}$  of all the light from the flame falls upon the track close to the engine. This small amount of light is all the engineer has to rely on to show him anything on the track nearby.

The reflected light which is poured into the darkness ahead is somewhat better, because there is more of it and it does not scatter so much, but it has to travel farther and the losses are heavy. Reflected light from any headlight does scatter to a certain extent, because it is impossible to place the flame exactly in the focus. When the light reaches an

object on the right of way, part of it is absorbed, even quicksilver absorbs 334 parts out of 1,000. The light which is not absorbed by the object is reflected in all directions, and it is only that portion of the light originally thrown ahead from the lamp, and which is reflected back in the direction of the engine, and so reaches the eye of the engineer, that reveals the presence of any object to him.

The parabolic reflector used in a locomotive headlight is a good working device, but light losses are exceedingly heavy, and the oil lamp is too feeble a source of light to be thoroughly satisfactory even with the best reflector. In view of these facts it would seem that the lighthouse method of throwing out illuminating rays might be applicable to a locomotive. In the lantern of a lighthouse the lamp is in the center of a ring of lenses, each of which is made up of a series of prisms which disposes of the light, in approximately level fan-shaped spokes which sweep out over the sea without a part being lost in the darkness above. Semaphore and signal lamp lenses are modifications of this principle which might be applied to the locomotive front end with good results. A locomotive headlight lens could be designed which would concentrate all available light on the track beginning a few feet ahead of the engine, and on for a considerable distance. It would light up the track, the whole track and nothing but the track, if one may so say. Such a lamp, with the electric arc or an acetylene flame burning closely in the focus of the lens, would give a powerful light always beating ahead, but only where, for safety's sake, the steady watcher in the cab of a midnight flyer must always look.

## Timber for Railway Ties.

It was recently said by a prominent railroad man on one of our trunk lines, and certainly with some degree of plausibility, that wooden ties have not been used as intelligently as they might be in this country, because where we get nine years' service from a tie, English roads get 21 years', and the atmosphere of the British Isles is much damper than that of America. The reason for this is said to lie in the fact that wooden ties in Great Britain are creosoted, about 2½ gallons being used per tie, and a very large tie-plate is used under the rail, and that between tie-plate and sleeper a piece of felt is interposed as a further protection to the wood. The tie-plate, or as it is called over there, the chair, is secured to the tie by spikes made of close grain fibrous iron, and sometimes with bolts, or trenails are used, the latter being simply a round oak peg.

The steel tie has been advocated as a substitute for the wooden sleeper, but the objections usually urged against a

metal supported track are stated to be the greater first cost of the steel tie; the steel tie does not last as long as the wood, when the latter is properly handled; and the steel tie is rigid and does not act as a cushion, or absorb the shocks which are produced by a train in motion. The wear and tear to rolling stock is greater on a steel laid road than on a wooden one, and consequently the comfort of those traveling over it is less than when wooden ties are used. Steel ties have to be specially insulated where track circuits are used in connection with automatic block signals.

The Atchison, Topeka & Santa Fe have for a number of years carried on a series of experiments for the purpose of finding the most satisfactory preservative for wooden ties and also the most suitable kind of wood to use.

At Somerville, Tex., this railway has an extensive timber treating plant. Every form of timber treatment known to science has been tried there with the result that for all practical purposes creosote has been found to be the best.

As an example of the extent to which the service life of wood may be brought, it is stated that creosote piling which has been in the Galveston bridge for nearly 15 years, is still sound and in good condition, while the average life of an untreated pile is less than one year.

The two great enemies of forest preservation in America are fire and taxes. The fear of loss by fire and the visits of the tax collector have in many cases forced the lumberman to cut all his timber as quickly as possible and then turn the land over to the farmer or leave it a wilderness of stumps. In Canada most of the forest areas are what are called Crown lands, and the right to cut timber which is sold by the Government and regulated by law, does not carry with it the actual conveyance of the land. In this way mature trees are taken out without destroying or injuring those which are coming on.

In order to provide material for ties several roads have taken up tree growing. In 1902 the Pennsylvania planted 14,000 yellow locust trees; in 1905, 197,000, and this year about 800,000 will be planted. The Michigan Central some time ago planted 80,000 catalpa trees. The Illinois Central have planted two large groves of catalpa, one at Du Quoin, Ill., and the other at Harahan, La. The Norfolk & Western tried catalpa in a grove of six acres at Ivor, Va., but since it has been found that loblolly pine grows better in that country, and large tracts have been planted with that species, the Northern Pacific are considering the planting of trees, and they are encouraging farmers along the line to plant. On the Pennsylvania, as white oak is becoming scarce, creosoted bull pine bids fair to be extensively used for ties.

### Modern Machinists.

The advent of the steam engine may be said to have called into existence the machinists' trade. The requirements of rapidly moving machinery outgrew the possibilities of the blacksmiths' and wheelwrights' trades, and fitters and finishers blossomed into being. In Europe in the early part of the last century these engineers, as they were called, assumed the dignity of a profession. The mechanics that graduated from the engine shops of Watt and Boulton commanded large wages. Some of them, indeed, got more for their labor than was good for them. Like heavy tragedians, some of them were accompanied by understudies, whose chief duty it was to see that their superiors were kept away from the ale house as much as possible. During the latter part of the century the machinists' trade gradually found its level. The last of the old guard of machinists that came in with the locomotive could be found all over America thirty or forty years ago. These patriarchs were mostly British, some with the hall-mark of the Stephensons upon them. Others were from the great engineering works on the Clyde. They could do great things with a hammer and chisel, but looked with contempt upon finer tools. They looked backwards and became crystallized, like Lot's wife. When they set the slide valves of a locomotive, common mortals had to stand afar off and gaze in dumb wonderment at the mysterious performance. Sometimes the sides of the steam chests of a locomotive were cast solid on the cylinders and nothing delighted the soul of the fossilized mechanical curiosity more than to take his prehistoric tools and face up the valve seats in their sunken recesses. Time was no object. You could look round next week and find him at his post like the sentinel at the gates of Herculaneum. Conceit warped his intellect and ran him into the eddies and shallows of his calling. That he filled a niche, or that he was a kind of tooth in the spur wheels of mechanical expansion is not to be denied.

The American machinist of to-day not only works as skillfully with hand tools where that is absolutely necessary, but he works much faster than did his predecessor. The modern spirit is utterly opposed to mystery and make-believe clap-trap. Every new device is welcomed and the past is properly looked upon as a stepping stone to higher and better things. The promulgation of a broader and brighter spirit comes from education, from the interchange of thought, and particularly from the wide circulation of literature that, like seed sown in the furrowed earth, blossoms into beauty and ripens into richness. The schoolmaster is omnipresent. The student is everywhere.

### Repair Shop Savings.

"In the average run of railroad machine shop work, excessive stock for finishing should not be there." This remark occurs in Mr. C. J. Crowley's paper, recently presented to the Western Railway Club. In dealing with the various savings which may be effected in railway repair shops, he takes up the question of the ability of modern machines to remove metal. He says the tendency of present day machine design is toward strength and massiveness, and the efficiency of a machine is generally gauged by its ability to cut deeply and quickly. To-day, railways are buying tools which in bulk, weight and working capacity are marvels, and that is all right. The modern machine, aside from its strength, is equipped with speed and feed adjustment attachments which are immensely valuable. These are no uncertain improvements, for they tend to increase ease, accuracy and speed of output. •

If there is an excessive amount of metal to remove, these are the machines to use, and the rational method is to crowd on power and get it off in the shortest time. It is the prevalence of this excessive stock on parts to be finished to which Mr. Crowley very wisely directs attention. Excessive stock means unnecessary initial expense for castings or forgings. Excessive stock on castings, he thinks, indicates poor pattern design, and the use of one pattern to fill several sizes needed, is secured at a saving in pattern shop labor, but at a heavy increase in the net cost of output.

These remarks remind us of a case which we heard of some years ago. A tenant wanted a landlord to put in some extra fixture in his house. The landlord agreed, if the tenant would pay a little more rent. The tenant refused, on the ground that in a short time he would have paid for the extra fixture and then he would have to go on paying higher rent for years, and so on to the end of the chapter. Under the circumstances, he found he could better afford to put the fixture in himself, pay the cost of it, and keep his rent where it was. The application of this landlord and tenant incident which we have just given is well exemplified in the remarks of Mr. Crowley, which follow:

"Let us suppose your road purchased fifty locomotives, carrying twenty-inch cylinders. The pattern shop, in making ready to meet repairs with castings, builds a piston head pattern, say, of the solid type. The foreman pattern maker knows the cylinders on these engines will wear larger and larger, hence prepares, in a way, for this by constructing a pattern which will finish for a 20 $\frac{3}{4}$  in. cylinder. What has he done? For all engines so damaged as to require new cylinders, for all cylinders bushed during

the life of the engines, perhaps for twenty years, the machine shop will continue to finish the piston head to twenty inches. Suppose the thickness of the piston is five inches. Each time this stock is removed there are twenty-five pounds of metal turned off which, at a net loss of 1 cent per pound, means a loss in metal of 25 cents. We all know it will cost more for labor to finish the piston head carrying this extra stock than were it reduced to a decent minimum. No matter on what machine this finishing of the piston head is done, the theory is the same. The needs of this particular lot of engines require at least two sizes of the patterns. These patterns are easily made and last well, the same core boxes will answer for as many sizes as are actually demanded."

In working cast iron there is a loss of about 15 per cent. of the borings and turnings. The iron dust is lost in every movement from tool to scrap bin. If the solid piston is of uniform thickness it can be finished on a wet grinder. The grinder will remove the sand, leave most of the hard scales and save 30 cents' worth of stock. It is possible to make patterns which will suit the best laid plans of the machine shop. When it comes to finishing holes, actual practice shows that a hole can be reamed for one-half what it costs to drill; therefore, wherever possible, it should be cored as large as practice will permit and finished with a reamer. The labor cost is one-half and the solid metal to be taken out of the hole is saved.

Many castings have lugs to fasten them to the faceplate. The metal in them goes back to the foundry at a scrap price, and there is always a loss incurred. Instead of doing this over and over, perhaps a thousand times in a year, a permanent chuck which will hold the casting will save the waste. In this connection we may refer our readers to a letter in the general correspondence department of RAILWAY AND LOCOMOTIVE ENGINEERING for May, 1906, page 204, which tells of the very kind of thing which Mr. Crowley advocates.

He also called particular attention to steel castings, as they are hard to finish. The speaker referred to brass work as well, and told of how he saw a look of satisfaction overspread the face of the demonstrator in a railway repair shop which he visited, as the machine they were looking at tore off metal from a driving box brass. He found that from  $\frac{3}{8}$  to  $\frac{1}{2}$  in. metal was allowed for on their patterns for finishing. The metal came off about as easily as if it had been  $\frac{1}{4}$  in. thick or less, but the extra stock taken off represented a loss. Castings of all kinds were referred to by Mr. Crowley, who is the shop demonstrator on the Chicago, Burlington & Quincy, at West Burlington, Iowa, be-

cause castings are so largely used in railroad work.

The same general principles as those advocated in regard to castings apply to the finishing of forgings. He said: "Hammered or forged iron may cost 3 cents per pound, while the scrap turnings or borings will not net over  $\frac{1}{2}$  cent per pound. If the frame forge men work carefully and keep the stock on a main frame within one-fourth inch all over, they will do their work as well as could be expected, but for every additional one-sixteenth inch there will be a dead loss of \$3 to \$4. Thus it is not always a question of how cheaply you can plane frames, but how best you can forge frames. Labor cost items are generally less than material cost items; therefore, it behooves every man in authority in these matters to watch his rough material."

#### To Exclude General Foremen from Master Mechanics' Ass'n.

Next year the American Railway Master Mechanics' Association will be forty years old. During these forty years of its existence general foremen have been admitted as members when their names were presented by their superior officers. Notice of an amendment to the constitution has been submitted to the association and will be voted upon at the 40th convention making general foremen no longer eligible for membership. We consider this a reactionary move and hope that the convention will not sustain the recommendation for this change.

On many small railroads the general foreman is the only representative of the mechanical department, and when he is debarred from membership in the Master Mechanics' Association the railroad is deprived of the benefit that comes from the connection with this useful organization. General foremen are in some respects the most useful members of the mechanical department and it seems unfair that anything should be done to lessen the importance of their position.

#### Railway Scholarships.

The Canadian Pacific Railway offer their employees five scholarships, each of which cover four years' tuition in the faculty of Applied Science in McGill University in Montreal. Two of these scholarships are awarded this year and the examinations took place last June.

The two candidates making the highest average and complying with the requirements for admission will be awarded the scholarships and have the option of taking a course in any department of the faculty of Applied Science.

Scholarships are renewed from year to year only upon the holders thereof passing satisfactorily the sessional and other examinations prescribed by university authorities. They are open to

all employees of the company under 21 years of age who are on the permanent staff and also to minor sons of employees anywhere on the road.

This is an important aid to the work of advancing technical education among railway employees and speaks well for the enlightened business policy of the company, from which they will reap benefit, as well as do those who receive the training.

#### Education of an Engineer.

The subject of the education of an engineer is being discussed with considerable feeling in the British press. For the average working engineer actual workshop experience cannot begin too early, in fact it should precede technical training. The evening school system has in many instances made an excessive demand on a boy's energy. The system introduced by Mr. MacIntosh, Superintendent of Motive Power of the Central Railroad of New Jersey, ought to be taken as a model for all engineering establishments. The boys are taught the technical branches of mechanical engineering in the company's time; they are paid for the time they are in school, and attendance is compulsory.

#### Tribute to Railway Men.

In a recently published article on the Railways of Africa, Lt.-Col. Sir Percy Girouard, director general of British military railways, speaks in high terms of praise of railway men. He says:

"From 1899 to 1902 the entire railway system of South Africa was submitted to the greatest strain a railway can endure—the test of what proved to be a great war.

"The devotion to duty and heroism displayed by the railway workers of South Africa during those days of strife will not be easily forgotten. Intrepid bridge builders and reconstructors of hundreds of damaged structures—engine drivers and firemen who died on their footplates, armored trains moved by fearless crews holding their lives of but little value for the general good. Yet notwithstanding disease, inevitable lack of organization, incessant attacks by the enemy, the railway man added then in South Africa a brilliant chapter to railway annals, marked through many failures, by success."

Concluding, he speaks not only of the struggle in South Africa, but of all wars, and thus pays a noble tribute to the work of railways and of railway men.

"The sword quickly drawn establishes supremacy rapidly, too often, however, leaving in its wake many, if not all the ill-effects, of a call to arms. The slower and more economical ideal—civilization advancing hand in hand with the railway—has never left behind it other than a heritage of material and moral progress."

### To Become a Locomotive Engineer.

A short time ago the Editor of Popular Mechanics requested Mr. Angus Sinclair to write down some of the reasons why a young man of intelligence and perseverance should become a locomotive engineer. The following is what Mr. Sinclair wrote, and it is reproduced here for the information and encouragement of those who are thinking of entering or who have just entered the motive power department:

In the prevailing struggle for existence, it is no easy task for a young man having no special training or technical education to decide upon a calling which is likely to give him permanent employment with fair remuneration. In surveying the field of available occupations, I do not find one which is equal to that of locomotive engineer for pro-

incompetence becomes a continual source of annoyance and danger, when the holder is privileged to perform the duties of a locomotive engineer. The first requisite of a would-be locomotive engineer is the possession of a good constitution and an estimable character, with steady habits. He ought to be naturally industrious and have a good common school education, be of observing habits, have good eyesight and hearing and be free from nervousness. He must also be courageous without being reckless and he must have the capacity of keeping cool under danger or difficulties.

If a man possesses these characteristics and knows that he has them, he can safely offer himself as a fireman, for his progress towards the right hand side of the engine is assured.

There are few lines of work where the faculty of concentrating the mind to the work on hand is so valuable as in that of running a locomotive. A man may be highly intelligent and be well endowed with general knowledge, but on a locomotive he will make a failure, unless his whole attention, while on duty, is devoted to the duties of taking the locomotive and train over the division safely on time. The man who lets outside hobbies or interests take much of his thoughts while running a locomotive, is likely to get into many scrapes.

People of a serious disposition are generally regarded with favor for responsible railroad employment, but I did not find that decidedly religious men made such good engineers as others less regenerate. Ahaziah Sims had drifted from the oil room at Springfield to fir-



STEEPLECHASE PIER AND THE FAMOUS STEEL PIER WHERE THE CONVENTIONS WERE HELD AT ATLANTIC CITY, N. J.

viding a good income and congenial employment for the right man. "The right man" is a very important factor in deciding who shall be accepted among the numerous candidates for the positions that lead to the position of locomotive engineer.

The average man who offers himself as a fireman with a view to becoming a locomotive engineer, gives himself no self-examination to ascertain if he has the attributes that will make a successful engineer; and therefore the officials controlling the employment have to be keen inquirers to prevent the wrong man from taking a place in the line that leads to the cab of a locomotive. This exercise of judgment is not always successful for some men to become engineers, who have not the natural capacity to care for any appliance as complicated as a wheel barrow, and their

The locomotive engine which reaches nearest perfection, is one which performs the greatest amount of work at the least cost for fuel, lubricants, wear and tear of machinery and of the track traversed; the nearest approach to perfection in an engineer is the man who can work the engine so as to develop its best capabilities at the least cost. Poets are said to be born, not made. The same may be said of engineers. One man may have charge of an engine for only a few months, and yet exhibit thorough knowledge of his business, displaying sagacity resembling instinct concerning the treatment necessary to secure the best performance from his engine; another man, who appears equally intelligent in matters not pertaining to the locomotive, never develops a thorough understanding of the machine.

ing, then by force of staying became engineer. He was a pious man and not only he, but others, imagined that his religious capital made up for no end of occupation shortcomings.

One morning Ziah walked smilingly into the roundhouse office from a night run and remarked: "Had splendid run. Engine all the way kept saying: 'Bless the Lord, Bless the Lord.'"

"I know vat vas de matter vid your engine, Zi," remarked Joe Dietz. "Your valves vas oud and you did not know id. Hims odt say: 'Bress de Good Lord' and den you haf four exhausts."

Ahaziah was less than a good average engineer, for he permitted his mind to praise the Lord in psalms when he ought to have been fondling his engine. Glorifying the Lord and his works is all right in its place, but it is better for an engineer on duty to be keeping a keen

ear on the deterioration of the pistons and valves or main rods, or air pump, or other part that is getting demoralized. Which of these pistons is beginning to blow? What is the matter with that injector that needs help, etc., etc.? The man who cannot devote his mind exclusively to the working of the engine and looking out for signals, when on duty, will not make a first-class engine.

I was a locomotive engineer between breaks for about twenty years, but I was in some respects a better engineer in the first five years of service than in the last five years. The cause of this degeneracy, so to speak, was, that latterly distractions had come into my life and I was not able to concentrate my attention upon the working of the engine with the same interest that I could apply when younger. My mind would wander to studying of scientific prob-

wet sand and 45 tons of dry; machine shop building, including an engine room 20 by 60 ft., boiler room 40 by 60 ft.; machine shop 60 by 90 ft.; oil and storeroom, with cellar 30 by 45 ft. with office 15 by 70 ft. for the General Foreman and Storekeeper. There will be a trainmen's building 35 by 50 ft., which will include toilet rooms for workmen; and on the first floor standard bath and locker rooms. The second floor of this building will have lounging and bunk rooms for the enginemen and trainmen. There will also be a standard 80-ft. turntable and a double ash pit 150 ft. long, to be equipped with hoisting crane and automatic grab buckets.

#### Fogs Here and Abroad.

Fogs are heavier in the British Isles than they are here, and on the railways over there they have to take greater precautions than we have. When a fog

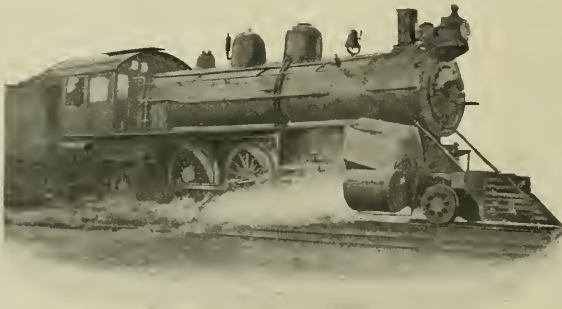

SUBSTITUTE FOR GOOD PACKING—CANVAS CURTAIN USED ON A WESTERN PASSENGER ENGINE.

lems that required too much attention.

Many hardships have to be endured by nearly all locomotive engineers, but the life has its compensations. A man who knows his business and performs his duties properly holds a very independent position. As to the attractions that might induce a young man to choose the business of a locomotive engineer, I testify that with all its drawbacks I do not know of a pleasanter business. It has been my good fortune to engage in many occupations—some of them of high grade—some of them of very honorable standing—but I never enjoyed any work so much as that of running a locomotive.

The Baltimore and Ohio Railroad intend to make extensive improvements to their terminals at Cleveland, Ohio, to provide for needed additional facilities required by the increase of business. The improvements will include the erection of a ten-stall standard brick roundhouse; a gravity coal tipple having a capacity of 300 tons; a sand house with a capacity for 35 cars of

settles down on an English road every distant signal in the fog zone is guarded by a man, who is supplied with torpedoes, flags, lanterns, etc.; the latter are called detonators on that side of the Atlantic. When the signal is set at danger two torpedoes are placed on the track to warn the engineer, and these are supplemented by a red lantern in the hands of the man. The torpedoes cost about a cent and a half each. There is a machine in use at each point where the detonators have to be placed on the track, by which the second torpedo is driven off the rail by the force of the explosion of the first, and before the train runs over it. Only one is necessary, the second being merely a precaution, and as these fog signals are used in great numbers, the machine for saving the precautionary second torpedo effects considerable economy, without leaving anything to chance.

The books which help you most are those which make you think the most. —Theodore Parker.

#### Wrong Listener.

A young girl sat in her bedroom with a novel. Her hair was down and her feet were in red slippers. Now and then, extending her white arms, she yawned. You see, it was very late, and down stairs in the drawing room her older sister was entertaining a young man. She naturally felt a deep interest in the entertainment. She was waiting to hear how it would terminate. And at last there was a sound in the hall, a crash as of a closing door, and it was plain to the impatient girl that the young man had gone. She threw down her novel and running forth peered over the balustrade, down into the hall's intense blackness. "Well, Maude," she called, "did you land him?" There was no immediate reply to her question. There was a silence, a peculiar silence, a silence with a certain strained quality in it. Then a masculine voice replied: "She did."

In referring to the Nathan Manufacturing Company's publications in last month's issue we spoke of the coal muffler and safety. It should have been the Coale muffler and safety valve, which is made by a company of that name in Baltimore, the sale of whose product has been lately secured by the Nathan Company. The way the name of this valve was printed, without the final "e" really showed a small saving in coale which is most commendable in connection with any kind of pop or safety valve. We therefore advise our friends to write to the Nathan Company of New York and make inquiry about this valve, or at least ask for the folder and be sure you spell the word Coale if you write.

#### Steel and Glass Bridge.

The State of Colorado will soon possess the highest bridge in the Western world and it will be over the deepest chasm in the Rocky Mountains. The bridge is being built over the far-famed Royal Gorge of the Arkansas River. This is the narrowest point in the Grand Canon of the same stream—the great gate, as it were, through which the Arkansas River empties its enormous volume of water, gathered from the melting snows 150 miles above, in the vicinity of Leadville, on to the plain once known as "The Great American Desert." At the point in the Royal Gorge where the bridge is to be stretched, the abyssmal rent in the earth's crust is but fifty feet wide at the bottom and 230 feet wide at the top. The walls rise almost perpendicularly for a distance of 2,660 feet, and are composed of granite iron-stained and with the colorings that blend into innumerable pleasing effects. It is said that the bridge will be built of steel and glass.

# Our Correspondence School.

In this department we propose giving the information that will enable trainmen to pass the examinations they are subjected to before being promoted. If any of our students fail to understand any part of the instructions, we will gladly try to make them plainer if they write to us. All letters intended for Our Correspondence School ought to be addressed to Department E.

## Third Series of Questions.

With this issue, we begin the third series of questions and answers. The questions are taken from the book published by a prominent southern railway, and this series will include such answers as will be asked concerning train rules and operation.

1. What is your name?  
A.—(Personal answer.)
2. How many years' experience have you had in railroad work? On what roads and in what capacities?  
A.—(Personal answer.)
3. Are your eyesight and hearing good?  
A.—(Personal answer.)
4. Do you use intoxicating liquors, if so, to what extent?  
A.—(Personal answer.)
5. What is necessary to make any rule or set of rules for the government of railroad employees efficient?  
A.—The rule or rules must be known and understood by all concerned.
6. Have you been supplied with a copy of the rules and regulations?  
A.—Yes.
7. What do they supersede?  
A.—All those previously issued.
8. What precautions are necessary before starting on a trip?  
A.—I should have my watch with me, and compare it with the company's standard time. I should have all special appliances required for my duties on the road, and the appliances should be in good condition.
9. What instructions, written or printed, should be in your possession while on the road?  
A.—The time table now in force, and the book of rules.
10. Are there special instructions for the government of employees in addition to the book of rules?  
A. Yes.
11. How must special instructions be observed?  
A.—They must be observed with care and particularity.
12. What employees must have copies of these rules?  
A.—All concerned in the operation of trains.
13. When must they have their copies at hand?  
A.—Always when on duty.
14. What knowledge must they have of the rules?  
A.—They must have a thorough knowledge of the rules.
15. What is the duty of each employe

with respect to their being carried out?

A.—He must not only carry out the rules himself, but must assist others in doing the same.

16. Do you understand that an employe is required to obey, and, therefore, to know all the rules and regulations, or only those applicable to his department?  
A.—All the rules must be known and obeyed.

17. What is your duty, in if doubt as to the meaning of any rule or special instructions?  
A.—I should apply to the head of my department for explanation of any rule about which I am in doubt.

18. Under whose authority are employes while on duty in the train service?  
A.—They are under the authority of the designated officer of the operating department.

19. Are any other persons than employes of this company subject to these rules? If so, what persons and when?  
A.—Persons authorized to transact business on trains or at stations are subject to the company's rules.

20. How often and when is standard time telegraphed to all points?  
A.—(Answer must show knowledge of the particular practice of the road to which employe belongs.)

21. What is meant by standard clocks?  
A.—Standard clocks are those designated by the company for the use of employes when regulating their watches and those by the time which trains are run.

22. Where are the standard clocks on this division located?  
A.—(Answer must show knowledge of particular practice of road to which employe belongs.)

23. How are they distinguished?  
A.—(Answer must show knowledge of

particular practice of road to which employe belongs.)

24. From what clocks only must train men and enginemen take time?  
A.—From standard clocks.

25. Have you a reliable watch?  
A.—Yes.

26. How is the reliability of watches to be determined?  
A.—By regular inspection by the company's designated watch and clock inspector.

27. How often must watches be examined and certificates be renewed?  
A.—(Answer must show knowledge of particular practice of road to which employe belongs.)

28. When must you regulate your watch by the standard clocks, and what is your duty after regulating your watch?  
A.—Before starting on a trip. Conductors and engineers must compare watches.

29. When your duties are such as to prevent you from access to standard clocks, how are you to procure standard time?  
A.—Standard time must be got from some employe who has regulated his watch in accordance with a standard clock as prescribed in the rules.

## Calculations for Railway Men.

BY FRED H. COLVIN.

Levers multiply distances moved as well as pressures applied, and a very common example of this is in the rocker arm used with every link motion, on any indirect connected locomotive, as most of them are. There it reverses the motion and also varies the travel between the eccentrics and the valve, as a usual thing. Calling the lower end of the rocker 8 ins. and the upper end 10 ins., we see from the examples given in May that if the power is applied to the short arm it will not balance as great a force at the other end. That is if we apply a force of 100 lbs. on the 8-in. arm it will only transmit 80 lbs. from the long end, because  $100 \times 8 = 800$ , and divide this by the long arm, 10 ins., gives 80 lbs. as the power transmitted. Reversing this, the power is transposed as shown in both cases in Fig. 1. Also note the difference in the travel of the two ends as this is an important feature which we will take up shortly.

Now passing to Fig. 2, we see the effect of a series of levers, all of the first class in this case, with the short arms 2 ins. and the long arms 4 ins. This doubles up the power every time,



TURNING AN ENGINE AT CHARKOF, RUSSIA

giving 20 lbs. at the top of first lever, 40 lbs. at the bottom of second lever, 80 lbs. at the top of third lever and giving a final of 160 lbs. or 16 times the initial pressure. The horizontal bars simply connect the ends of the levers and transmit the power but do not alter it.

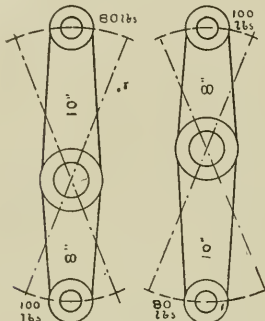

FIG. 1. ROCKER ARMS.

Fig. 3 gives a combination of levers, all pivoted at the top, at *C E G* and *J*. Lever *A C* is 6 ins. long with power applied at *A* and taken off at *B*. So we multiply 6 by 10 = 60. Divide this by 4 and we have 15 lbs. as power transmitted from *B*. Lever *E D* simply transmits power, the same as is done in some forms of valve motion when the motion is carried over the front axle. This power is still 15 lbs. at the lower end of *G F*. Here the power arm is also 6 ins., so we multiply 6 by 15 = 90, and as the power is taken off at 2 ins., divide by 2 and get 45 as power transmitted to the fourth lever at *I*. Here the power arm is 4 ins., *I J*, so we multiply 45 by 4 = 180. Divide this by the weight arm *K*,



FIG. 2. SERIES OF FIRST CLASS LEVERS.

6 ins., giving 30 lbs. as the final force transmitted. This shows how power is increased and decreased by the various connections of the levers.

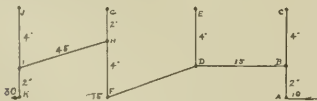

FIG. 3. LEVERS PIVOTED AT THE TOP.

In Fig. 4 we have practically the same leverage arrangement as in Fig. 2, which we can call a brake lever system, although none are connected up in just this way. The same multiplication takes place as before. In this case we have taken into consideration the distance traveled by the ends of the levers as this

has a very important bearing. Suppose the lower end of lever at *H* moves one inch, then *G*, at the end of upper arm, will move 2 ins., because the upper arm is twice as long as the lower arm, as the figures show. Point *F* moves the same distance, but *E* again doubles up and moves 4 ins. Point *D* moves the same amount and *C* travels 8 ins., which is doubled when it gets to *A*, making *A* travel 16 ins. This shows us that the power is multiplied 16 times between *A* and *H*. It also shows that the movement necessary at *A* to produce this result at *H* is 16 times as great as at the final application of the power.

This brings us up against the old law of nature that it is impossible to get something for nothing. What we gain in power we lose in distance. In other words, the power applied, multiplied by the distance through which it moves, must equal the power delivered multiplied by the distance through which it travels. This is always true in any combination of levers. If you measure the distance traveled by the end to which power is applied and divide this by the distance through which the other end of the combination moves, you have the leverage of the combination without figuring out a single length of lever. No matter how long your train of levers, measure the travel of the brake shoe between full release and application. Divide the piston travel of brake cylinder by this and you have the effective braking leverage. Of course this does not allow for springing of levers of connections, but it gives you results with very few figures.

Perhaps one of the most puzzling things about levers in connection with a locomotive is the question of the driving wheel, and it's very easy to run up against a snag. If you jack an engine up in the air and run it, there is no question as to the axle, but when you drop it down on the rails the dispute begins and the question of what makes it move is almost as pressing as the old conundrum, "Who struck Billy Patterson?"

In Figs. 5 and 6 are the outlines of a cylinder, piston and a driving wheel with four spokes so as to give the appearance of a lever with one end resting on the rail. Now if we take Fig. 5 and admit steam into the front end of the cylinder it is very clear that the crankpin will be forced backwards just as though it was the upper end of a lever and the other end resting on the rail. The same thing occurs if we admit steam to the other end of cylinder, only the lever is pulled the other way. And it can be readily seen that this is precisely what happens in the case of the wheel. But when we come to Fig. 6 it's a different case. Here the crankpin is below the center, and if we push on it, considering the end of the spoke fixed on the

rail, it will turn the wheel backwards just as it did before. Or if we pull the other way it will pull it forward, and yet we know that nothing of the kind happens when the steam is turned on, for the wheel turns exactly the same

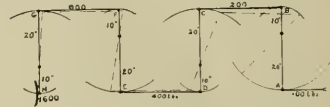

FIG. 4. BRAKE LEVER SYSTEM.

whether the crankpin is above or below the center.

You can do a little experimenting with your boy's express wagon that will be

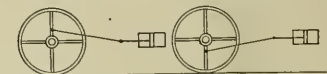

FIG. 5. ABOVE CENTER.

FIG. 6. BELOW CENTER.

helpful in solving some of these things. Stand on the ground beside it and take a stick so you can push against the spokes at any point you please. Push at any point above the center as in Fig. 5 and it moves away from you. Push against a point below the center, as in Fig. 6, and it still moves away from you. Now get in the wagon, or on it in some way, and push against the same places on the spokes. When you push above the center it moves away from you, but when you push against a point below the center it moves toward you, just as it does when the engine takes steam. As the engine is run by steam, applied in the same way, it is pretty safe to assume that this is the right way and that considering the wheel as a lever with one end fixed on the track, is not correct.

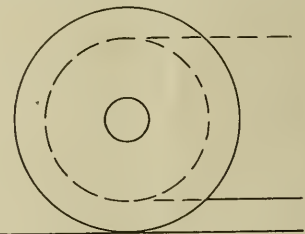

FIG. 7. ROLLING A SPOOL.

This is all right as long as the power is applied from outside the moving body, but when applied from a point on the moving body itself, the same principles apply as in a stationary engine or when we jack the engine up off the track and run it. Another interesting example of this can be had with a common spool of thread, as shown in Fig. 7. If we turn the spool so that the thread unwinds from the top, and pull on the thread, the spool rolls toward you. Now re-



verse the spool and pull the thread from the bottom and the spool still rolls toward you, because you are pulling on a point above the contact between spool and the table or whatever it is rolling on.

Tie a rope to your boy's wheel at any point and you get the same thing as long as you stand on the ground. But when you get on the wagon and pull, you find the case just as when you pushed on the spokes with a stick. Another way that we gain power or rather use power with more advantage is in using different sized pistons, in such cases as hydraulic rams or jacks. We never gain power any way, that would be to get something for nothing. Nature doesn't work that way. When you are able to lift a great weight by means of a lever, it is because you apply a smaller force through a greater distance. This holds true with differential pistons, or gears, or any other form of apparatus.

Suppose we apply 50 lbs. pressure on a lever which gives an increase of 10 to 1, making 500 lbs. at the business end of the lever. This end operates a small piston, one square inch in area, so that it gives a pressure of 500 lbs. per square inch. This pumps against a larger piston of 10 square inches, so that, with 500 lbs. pressure on each square inch, there is a total of 5,000 lbs. on the large piston. It can also be seen that, if the one-inch piston pumps one cubic inch of liquid at a stroke, it will have to spread out over 10 times the area in the big cylinder and only give a movement one-tenth as much. This figures down to the fact that, while we multiply the power 100 times we move the hand or other source of power 100 times as far as the load is moved. This is the principle of all hydraulic jacks.

## Questions Answered

WANTS TO BE A GOOD FIREMAN.

(61) T. R., Paterson, N. J., writes:

Would you say how I can procure a position on a railway as fireman? Would it be necessary to go through a course of instruction such as is advertised by some institutions for teaching how to do railway work? A.—Apply to the nearest master mechanic for employment on a railway and if you are taken on, be ready and willing to go at the work in earnest, with the intention to make a success of it. If one master mechanic can't take you, another may. It is not necessary to take a course of instruction in any institution. Do your work whatever it is thoroughly, and in your spare time study some good helpful books on engineering subjects. RAILWAY AND LOCOMOTIVE ENGINEERING will help you and we have all the books you need, but

remember success depends on your own efforts and your own character.

CAUSE OF INCREASING LEAD.

(62) H. E. M., Denver, Colo., asks:

What causes the lead to increase on a locomotive as the reverse lever is hooked up? A claims it is caused by the radius of the link. B claims that the radius of the link has nothing to do with it. Which is right? A.—The alteration of lead which occurs when the reverse lever is notched up is due to the fact that the centers of each eccentric are some distance apart and therefore each eccentric rod end describes its own arc. If the eccentric straps surrounded the axle, and the curvature of the link was struck from the center of the axle, both eccentric rods would have the same center, and no alteration of lead would be caused when the reverse lever was raised or lowered. As it is now, the raising of the link causes the rods to revolve about different centers and their ends describe different arcs. This would take place if the link was straight, so that A is not strictly correct in what he says.

GRATE AREA AND HEATING SURFACE.

(63) M. De W., Oak Hill, N. Y., asks:

How much grate area should there be for each square foot of heating surface with a soft coal burner, and how much with a culm burner? A.—With soft coal burners, as a general rule, the grate area is about 1/70 of the heating surface, and for culm burners about 1/30 of the heating surface. In this, as in other things, circumstances alter cases, but roughly speaking these proportions are fairly accurate. A study of the engines illustrated in RAILWAY AND LOCOMOTIVE ENGINEERING to June this year shows: Soft coal burners, Jan., B. & O. 2-8-0, have 49.1 sq. ft. of heating surface to 1 sq. ft. of grate area; Wash 4-6-0, 83.4 heating to 1 of grate; Feb., D. & W. 2-8-0, 60.1 to 1; Monon 4-6-2, 66 to 1; March, Frisco 4-6-0, 61.9 to 1; M. K. & T. 4-6-0, 92.8 to 1; April, B. & M. 2-8-0, 61.5 to 1; N. C. & St. L. 4-6-0, 78.5 to 1; May, O. S. L. 4-6-2, 61.5 to 1; June, N. & W. 4-6-2, 76.1 to 1; Southern 4-6-2, 71.4 to 1; culm burners Jan., C. P. R. 4-6-0, 30.4 to 1; May, D. L. & W. 4-4-0, 24.4 to 1. The average of these soft coal engines is 69.3 to 1 and of the culm burners 27.4 to 1.

DIFFICULT TO NOTCH UP.

(64) I. E. N., Logansport, Ind., writes:

Why is it that when you are running an engine at a fast rate of speed and you drop the reverse lever from the working notch in the quadrant to the corner, that you cannot hook the lever back again until you slow down the train? A.—There is always a certain

amount of friction between the eccentric sheaves and the eccentric straps and when running at a high rate of speed this friction tends to carry all the eccentric rods round with the eccentric. If they were free to do so, they would revolve round the axle like the spokes of a wheel. This causes a strong downward pull of the hook on the saddle pin, when running forward. The rods are, however, fastened to the link which is held in position by the saddle pin, hangers, tumbling shaft and reach rod. Further than this, when the reverse lever is notched up, the valve travel is short and the link oscillates so to speak about the link block. When the link is let down the valve has full travel and the slot of the link with the link block in it swings through a greater arc at the location of the link block than it did before, so that in the process of raising the link you would have the link slot often almost broadside to the direction in which the link must move to notch up and this makes it harder to lift. When using steam, whatever unbalanced pressure there is on the valve also makes the link harder to lift, because the rocker arm is harder to move, especially in what we have called the almost broadside position of the link slot. With steam shut off and speed reduced, friction everywhere is reduced, and the pull down of the link on the saddle pin is less.

GOOD AND BAD STEAMERS.

(65) S. O. S., Millvale, Pa., writes:

Our road had a number of freight engines built at the Baldwin works, and a few of them were sent to the division on which I am an engineer. Some of these engines were great steamers and two of them would hardly make enough steam to get along with on the road. They kept getting worse and finally had to be taken into the shop. The nozzles were made smaller and the front ends were altered on several occasions, and still the engines did not make very much steam. Now that the boilers are clean valves good and square, packing in cylinders in good condition, no leaks in steam pipes and nozzles tight on base; can you tell why one engine will make plenty of steam and the other one still make very little steam, and both of them are new engines? A.—There may be several reasons why one steams and the other does not. One may be fired better than the other, or the smokebox of one may draw air through some undiscovered leak, or the exhaust may not be in line with the stack. Some engines said to steam badly have been found to have had insufficient throttle opening.

WEAR OF MAIN DRIVING WHEEL TIRES.

(66) G. E. C., Newton, Kan., writes:

I am running an engine here, a 2-6-2 type. The tires of the six drivers are

all tempered the same, but both main tires are worn  $1\frac{1}{2}$  inch smaller than the rest. Why is it? A.—Main driving wheel tires as a rule wear faster than the others because they are subject to the pressure of the main rod which tends while turning the wheel to press it down on the rail. The shorter the main rod the greater this tendency. It is also attributed to the main drivers being slipped by the cylinder power until the lost motion of the rods brings the surplus cylinder power to bear on the other coupled wheels. There is also a tendency, when the engine is running forward and working hard, to transfer a portion of the weight carried on the engine truck and forward drivers to the main drivers, assuming that they are the intermediate pair, thus increasing the load they have to carry; as a consequence, the greater amount of work they have to do results in greater tire wear. Sometimes the sand pipes are located so as to drop the sand immediately in front of the main drivers, which tends to cut them a little faster than if dropped in front of the forward drivers. It is possible that in your case the main tires may carry somewhat more weight than the others, due to the unequal distribution of weight over all the wheels, though intended to be alike, or your main tires may be a little softer than the others, although supposed to be tempered the same.

#### WATER LEVEL WHILE WORKING STEAM.

2. The gauge cocks and the water glass and cocks are in first class condition. The lowest gauge cock is located about  $6\frac{1}{2}$  inches above the crown sheet level, and the bottom water glass cock is about 2 inches above the crown sheet. There are no bolts, bars, or stays in behind these gauge cocks. But why is it, at all times when water is above crown-sheet and engine working, I can draw water through any of these cocks regardless of where the water level is? A.—The location of the bottom gauge cocks appears to be rather high, and if the water level, while engine is shut off, is not lower than this cock, then there is nothing surprising in the fact that you can get water from any of the other gauge cocks while the engine is working. If, however, when the water level is only 2 inches above the crown sheet when the engine is shut off, you can get water in the top gauge cock while working steam, it would seem that the location of the throttle and also of the dry pipe that supplies the fountain head, and possibly the fact that the spacing between the top and bottom gauge cocks is very small, all combined may be responsible for the result you experience. Bad water would help considerably. With the throttle and dry pipe to fountain head located well back over the crown sheet,

the entraining action of the steam will be more noticeable.

#### PRESSURE CONNECTION OF SAFETY VALVE.

(67) C. S. K., Toledo, O., writes:

Please explain how it is that the safety valve, when used with the distributing valve, relieves the brake cylinders of extra pressure? It does not seem large enough to take care of all the air that must escape from those large cylinders to reduce the pressure to the right amount. A.—The safety valve is connected to the distributing valve, and is in communication with chamber *g* of the latter when the equalizing piston and slide valves are in service position. When the pressure in chamber *g* is greater than 53 lbs., which is the amount at which the safety valve is set, it opens and relieves this chamber of the surplus pressure. Then the pressure in chamber *c* brake cylinder pressure, forces the application piston back until the exhaust valve 16 uncovers the exhaust ports from the brake cylinders to the atmosphere and allows brake cylinder air to escape until the pressure reduces to an amount equal to that in chamber *g* and the application chamber.

In the emergency position of the equalizing piston and slide valves, there is a small port connection between the main reservoir supply *a* and chamber *g*, which supplies air to this chamber just a trifle slower than the safety valve can dispose of it. On account of the brake valve equalizing reservoir being connected to chamber *g* and to the application chamber in emergency applications, the pressure in these chambers equalizes at about 60 lbs., and the small supply from passage *a* causes that pressure to be maintained in these chambers until the release. With the distributing valve, brake cylinder pressure is always equal to the pressure in chamber *g* and the application chamber. Hence, it will be seen that the safety valve has only to regulate the pressure in these chambers in order to effect a proper regulation of brake cylinder pressure.

#### ABOUT TO STALL.

(68) I. E. N., Logansport, Ind., asks:

Why is it, that when you are on a hard pull, and are about to stall and you drop the reverse lever from about the fourth notch from the center to the corner of the quadrant, your engine will almost invariably stop? A.—When you have observed this state of affairs, that is on a heavy pull and lever notched up, the chances are that the engineer has been getting up the hill as far as he can, largely on the momentum of a run at the grade, and that he has waited too long before dropping the reverse lever down. Sometimes an engine with a long train running down one hill and

up another, may not be able to get over without the aid of a good run at it. If an engine going pretty fast on the hill had its reverse lever dropped down too soon, the heavy exhaust would be choked and the speed reduced, and so the lowering of the reverse lever is delayed as long as possible. The farther up the hill the front of the train gets, more of the rear portion comes off the down grade and goes on to the up grade. So that if the full power of the engine is not exerted until too late, the engine will stall. This is on the assumption that both full power and a good run at the hill, are necessary to get over the grade.

#### CAUSE OF BUCKLING.

(69) J. McK., New Haven, Conn., writes:

We have had more buckling of trains last winter than ever. What is the cause of it? A.—Buckling usually occurs on long trains, that are partially equipped with air brakes, and it is the result of the rear running up hard against the forward end when a heavy application of the brakes is made, crushing and derailing some of the weaker cars that may be located toward the middle of the train. When trains "buckle" that are fully equipped with air brakes, it is usually found that the make-up and arrangement of the air brake equipment is responsible for it; such as two or more cars close together at the head end with their triples cut out and non-standard triples located close to them; non-standard triples cut in and working, but placed close to the head end of the train or next to the engine; and heavy paper gaskets placed in the hose couplings that restrict the flow of air in the pipe. These conditions prevent quick action being had when the engineer tries to make an emergency application; and the result is the brakes apply hard on the front end of train before they commence to take hold on the rear, allowing the latter to run up hard against the former with damaging effects. Where buckling occurs on a road of more than one track, the danger to trains running on the other tracks, in either direction, is very great, owing to the fact that the derailed cars often block those tracks.

#### Canadian Railways.

A branch of the Canadian Pacific Railway, 80 miles in length, is being constructed from Strasburg to Saskatoon. The Grand Trunk Railway is also building a section from Touchwood Hills to Saskatoon, a distance of 137 miles. Both branches are expected to be completed this year and it seems to be a race as to which will reach the desired point first.

# Air Brake Department.

CONDUCTED BY J. P. KELLY.

## Air Brake Convention.

The Air Brake Association held its thirteenth annual convention in Montreal, Canada, commencing on the morning of June 5.

Shortly after 9 A.M., President Leroy M. Carlton called the convention to order, and introduced His Worship Mayor Ekers, who welcomed the members, extending to them the hospitality of the city, and wishing them a pleasant visit and a successful meeting.

appreciation, the president addressed the members. In his remarks he called attention to the importance of considering carefully the demands which modern railway equipment and methods of transportation were making on the air brake service, and to the urgent necessity of improving on present air brake practice to meet these requirements.

He also referred to the improvements which had been made in air brake apparatus during the past two years, made

proving the present practice with respect to installation and maintenance of air brake equipment on engines and cars.

The discussion which followed the reading of the paper was participated in quite generally and it brought out much interesting and valuable information.

In disposing of the subject, it was decided to submit the recommendations to the whole association membership for consideration, and that their adoption



MEMBERS OF THE AIR BRAKE ASSOCIATION, FRIENDS AND GUESTS AT THE CONVENTION, MONTREAL, CANADA

Following Mayor Ekers, addresses were made by Mr. H. H. Vaughn, assistant to the Vice-President of the Canadian Pacific Ry.; Mr. W. E. Fowler, M. C. B. of the same road, and Mr. J. T. Chamberlain, M. C. B. of the Boston & Maine road. These gentlemen warmly praised the work which the Air Brake Association had done in the past, and expressed the hope that the present convention would be a successful one, and that the work accomplished would result in increased benefit to the railroads in helping to devise means for the betterment of the air brake service.

After thanking these gentlemen for their expressions of welcome and of

necessary by modern heavy locomotives and cars, and recommended that the association take into its membership those who have to do with the care and handling of air brakes in electric traction service.

The secretary's and treasurer's reports were then read. They revealed a very satisfactory condition of the association's affairs. The membership is now larger than ever before—about 800—and the financial condition is sound.

The first paper to come before the convention was that on "Recommended Practice," read by Mr. S. G. Downs.

This paper dealt in a conservative manner with various methods of im-

be decided by letter ballot. The session then closed.

In the afternoon a special train, furnished by the C. P. R., took the members and their ladies on a visit to the Angus shops, and they were shown all the departments of these works, which we believe, are the largest of their kind in Canada. The visiting members were very favorably impressed with what they saw, and returned to Montreal well pleased with the trip.

In the evening many of the members attended the informal ball, which was held at Stanley Hall.

On Wednesday morning, promptly at 8 o'clock, the members came to order,

and the paper on "Stencilling Cars; Best Method for General Adoption," was read by Mr. John Alexander. The discussion which followed the reading of the paper brought out a diversity of opinion regarding methods of stencilling, and showed that an efficient defect card system was a valuable factor in bringing forth good results in connection with stencilling.

Following this paper came one on "Recent Improvements in Railway Brakes by the Westinghouse Air Brake Company," by Mr. E. H. Dewson.

On account of the length of the paper it was read in abstract by the author. It dealt quite extensively with the improvements in air brakes for electric traction service, and was largely educational in character.

Mr. F. E. Wentworth then read a paper which described the recent modi-

fications in the New York engineers' brake valve, Style B 2, and explained the brake pipe pressure controller and the brake pipe service reduction acceleration valves recently brought out by that company. After a brief discussion on this paper, Mr. C. C. Farmer read a paper on "New Types of Westinghouse Triple Valves," which proved to be the most interesting feature of Wednesday's session. Although the paper contained many illustrations of the various triples considered, large diagrammatic drawings of the new K triple were used to assist the members in obtaining a clear and comprehensive idea of its construction and operation. Mr. Farmer was assisted by Mr. W. V. Turner, Mechanical Engineer of the Westinghouse Air Brake Co., who answered the various questions asked by the members concerning the possible action of this type of triple under different make-ups of long trains, and combinations of brakes, giving clear and satisfactory explanations to each. On account of the num-

ber of different triple valves to be considered in this paper, the subject was carried over until the next day. After the close of the second session the members and their ladies boarded the special train furnished by the courtesy of the Grand Trunk Ry., and started on a trip to Ottawa, where on arrival, street cars were provided by the Ottawa Electric Ry. Co. for a trip around the city. This proved a most delightful sight-seeing trip, and gave everybody a good appetite for the dinner which awaited them on arrival at the Grand Union Hotel.

In the evening the Senate and the House of Commons were visited, the members being shown through the buildings by the attendants, who very courteously described all objects of interest.

On Thursday morning, the third session opened promptly at 9, and by the

proper interpretation of the law with reference to the use of air brakes, and the replies cleared up the doubtful points. A vote of thanks was given to Mr. Borland by the association.

A paper by Mr. T. H. Draper on the subject of "Two Air Pumps vs. One on the Locomotive," followed by another by Mr. S. J. Kidder on "Westinghouse Compound Pumps" were read, and afterward discussed jointly. The opinions of many of the members favored the idea of equipping the locomotive with two pumps for reducing the possibility of pump failure and consequently of engine failure. The question of pump capacity, as having any bearing on the two-pump question has been entirely eliminated since the advent of the large compound pump.

After disposing of the papers on the pumps, the paper on the "Development of the New E T Locomotive Air Brake Equipment" was read by Mr. F. H. Parke. This paper, like the one on the triple valves, was illustrated by large diagrammatic drawings, having movable parts, and the reading of it was listened to with a great deal of interest. In the discussion which followed the reading of this paper Mr. Turner explained all points in connection with the equipment which were not clear.

After finishing with the paper on E T equipment adjournment was taken until 2:30 p. m. At the afternoon session the business of electing officers for the ensuing year was disposed of and the following is the list of officers for the coming year.

President, W. P. Garrabrant, Penn. R. R.; first vice-president, Geo. R. Parker, Great Northern Ry.; second vice-president, P. J. Langan, D. L. & W. R. R.; third vice-president, W. C. Hunter, N. B. Coal & Ry. Co.; secretary, F. M. Nellis, Westinghouse Air Brake Co.; treasurer, Otto Best, N. C. and St. L. Ry.

Executive members: W. C. Huntley, C. and O. Ry.; J. R. Alexander, Penn. R. R.; W. H. Wahlert, T. P. Ry.

The business of the convention finished, as many as could accepted the trip to Quebec, provided by the Intercolonial Ry., remaining there over night.

The next morning was spent in sight-seeing about Quebec, then a trip to the shrine of Saint Anne DeBeaupre, and afterward a visit to Kent house and the falls of Montmorency. At Kent house a luncheon was given by the Canadian Westinghouse Co., Limited.

The trip to the shrine of St. Anne and to the falls of Montmorency was tendered by the Quebec Railway Light and Power Company. Leaving the falls of Montmorency, it may be said that the breaking up of one of the most successful air brake conventions ever held in the history of the association from any-



OFFICIAL TRAIN OF HIS EXCELLENCY THE VICEROY—GREAT INDIAN PENINSULA RAILWAY.

unanimous desire of the members present, the discussion on the K triple valve was continued.

After finishing with the triple valves, Mr. W. P. Borland of the interstate commerce commission, was introduced. Mr. Borland addressed the convention, and in his remarks stated that at present about 88 per cent. of the cars in the United States are now equipped with air brakes; that the maintenance of air brakes is better than at any previous time; and that about 44,000 more cars were inspected last year than in any previous year. He called the attention of the air brake men to the importance of always placing a defect card on a car when necessary to cut out the brake on it.

In reply to the question of a member asking what course to pursue in case an air pump failed on the road, he stated that the train must be side tracked until the pump is repaired, or another locomotive procured. He also answered many other questions relating to the

point of view, was begun, and all departed for home feeling well repaid for the time spent in convention and carrying with them a warm appreciation of Canadian hospitality.

**Safety Angle Cock.**

Editor:

We present for the consideration of your many readers a half tone engraving of an improved form of angle cock for both passenger and freight cars, which it is thought has some good features.

As will be seen, it differs but very little from the present cock in form and manner of operating; the changes made are very slight, and they do not in the least change existing conditions. Briefly stated, the changes consist in simply reversing the position of the key in the cock body, thus bringing the handle end to the underside, and in changing the hose end of the cock from a straight line to a forty-five degree angle.

The advantages claimed are as follows: The handle being brought along side and back of the hose is better protected from flying missiles, thus lessening the liability of the cock being accidentally closed from this cause. It is impossible for dirt and grit to get in between key and bushing when from any cause the key becomes in the least unseated.



SAFETY ANGLE VALVE—FRONT VIEW.

This often happens, and is the direct cause of many cases of leaky angle cocks. A small supply of oil can be carried in the spring chamber on top of the key, if so desired, which would perhaps in a degree prevent it becoming dry and hard to operate.

It cannot be accidentally closed by loose train pipes; by a too close contact to buffer block or other parts of the

cars, by swinging, safety, or other chains; or by persons stepping on it when in the act of crossing between cars; and last, but not least, it removes completely the excuse of "loose train pipe, closed angle cock," so often presented to account for "brakes failing to work" (?) at the moment when they are most needed.

The forty-five degree end is for the purpose of bringing the hose in proper alignment without kinking when coupled to another hose.

The position of the handle as shown is not arbitrary, and might be brought up higher and above the hose, or lowered and of a different shape if thought

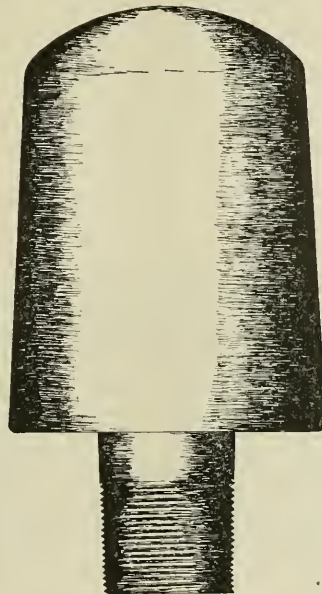

AIR STRAINER FOR PUMPS.

desirable, but in the opinion of the undersigned, the design as shown in the illustration is much the best.

REGULAR SUBSCRIBER.

**New Air Strainer for Pumps.**

Editor:

A great many articles have been written on the air strainer, and we have tried several different kinds of them, with very poor success, owing to the large amount of dirt on our streets, and to the gas and cinders in our tunnel, which is about one mile long.

The air inlet, of which I send you a cut, has proven to be a thorough success. The main aperture of this device is of such large diameter that the draft through it with an eleven-inch pump working at seventy strokes per minute

will not draw articles into it large enough to interfere with the air valve.

Drippings from the pump governor and from the cylinders of the pumps cannot get into it; it is also impossible for an engineman to put any oil into the pump through this inlet. Furthermore, I figure it increases the capacity of a



ANGLE VALVE—HOSE PROTECTING HANDLE.

pump about ten per cent. by getting air free from friction.

T. H. RENAUD

Air Brake Repair Man,  
Term. R'd. Ass'n., St. Louis, Mo.

**Railroad Maps.**

Complaints are being heard from Europe against the pernicious practice of publishing railway maps out of scale, thereby deceiving the public, who for this reason hardly know where they are at. It appears that the old reliable London and South-Western Railway is now as bad as the rest. Their map shows the city of Brest in France on the same longitude as Southampton, instead of being, where it belongs, in line with the Eddystone Lighthouse. One would suspect that a mighty earthquake had moved the earth and the waters under the earth.

Of course there is a method in this madness. The idea is to make it appear that this or that road is the most direct from some populous center to another. In the summer time when people take to the woods or to the seaside, it seems to us that this twisting of locations defies their very purpose. At any rate there is some comfort in knowing that the Polar star is still at the old place. As to the landmarks of Europe we can only exclaim in the words of the companion of the carpenter in "Midsummer Night's Dream"—"Thou art translated!"

### Special Steel Flat Car.

The General Electric Company of Schenectady, N. Y., have had some steel flat cars built for the transportation of heavy machinery. They are of the type shown in our illustration, and at the same time we are able to present a view of the standard type of switchman used on American railroads. Both are well able to stand up to the hard work that comes their way.

The car is made of steel plates and shapes, and weighs 47,500 lbs., and the carrying capacity of the car is 120,000 lbs. The other dimensions are: Length, 40 ft. 7 ins.; height, 3 ft. 2 ins.; width, 9 ft. 2 ins.; length of well, 11 ft. 9 ins.; width of well, 6 ft. The style of material this car is designed to carry is armatures and bases of heavy electrical machines and also the revolving fields of generators, etc. The opening in the center permits the parts to be set low on the car. As will be seen in the engraving, this opening is closed with a trap-door, so that the car can be used for carrying very heavy castings or other ma-

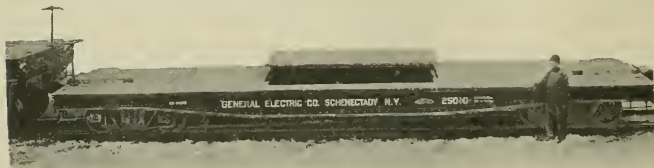

SPECIAL STEEL, FLAT CAR, 120,000 LBS. CAPACITY.

terial, in the usual manner. Although the draw gear is at the standard height from the rail, the deck of the car has been made as low as possible and the coupler rigging is covered by a flat steel plate. There are no through center sills, those which are used are made of I-beams and extend from the body bolsters to the end sills, and to these the draw gear is attached.

The principle of bridge construction is embodied in the side sills and in this regard it is an example of a heavy car adapted to a special purpose. Elsewhere in this issue we present an example of a car in which the use of side sills has been practically dispensed with, for special reasons. Both these types of cars afford profitable studies to those who are interested in the steel car builders' art. Both have special functions and both are good examples of the adaptation of means to an end.

### Judging Locomotive Speed.

Some years ago the Mechanical Engineer when dealing with the ability of engineers to judge speed said: "An engineer accustomed to large drivers loses time if transferred to an engine

with small drivers. He gauges speed by the motion of the crosshead, which in this instance is rather deceptive. Similarly, a man used to small drivers over-runs if transferred to larger wheels."

From experience gained on the foot-board, we are disposed to think that our contemporary's remarks apply only to young engineers, who have not learned a very important part of their business, namely, judging speed. As on most locomotives the motion of the crosshead can not be watched from the cab unless the engineer pushes his head out of the side window, it is certainly a rather deceptive way of judging speed, especially on a dark night, or when the thermometer has lost its way down in the bulb. An engineer who had to watch the motion of the crosshead on such a night in order to tell how close he could come to his meeting points, would be apt to come in without part of his right ear. Nearly every engineer can tell pretty accurately how fast his engine is running, under circumstances that would be terribly confusing to a

while a rough piece of track would make a raw runner think he was getting over the road at terrific speed, when he was losing time. The instinctive power of training raises the experienced engineer above the influence of deceptive surroundings, and in the worst night that blows, the click of the wheels on the joints, the rumble of the wheels on the rails, or the flash of light on a passing object, enables him to tell how he is getting along, but the crosshead is very seldom seen between stations.

### The Alaska Central Railway.

About 50 miles of the Alaska Central Railway is now in operation, and the work of construction is being carried on with a degree of rapidity that bids fair to reach from Seward on the Pacific Ocean, to Fairbanks, a rising city in the Yukon Valley, in the course of a year or two, the completed distance being 450 miles. The proposed route is direct to the heart of the mining districts, and near the confluence of the Yukon and the Tenana, the two great waterways of Alaska. The difficulty has been not only in getting a sufficient number of men to go so far north, but also in keeping those who do go. The temptation to go prospecting in summer is very great, and in winter many are discouraged and return. There is at present about 1,500 men at work. The Sushitna Valley, along which the road will run, is said to be of great agricultural importance. At present it is almost entirely covered with spruce, with rich bottom lands. Oats and rye have been very successfully cultivated by the Indians. Feed for livestock grows in abundance. The mountain scenery is rugged and grand. Mt. McKinley, the highest peak in the North American continent, being 20,464 ft. The timber line ceases at about 3,000 ft. up, and the mountain peaks are snow-clad like the Alps. The rocks are largely granite and conglomerate, with much evidence of former volcanic activity. Gold is found embedded in quartzose rocks, but the main interest of the Alaska Central Railway is in the coal fields which it is the intention of the promoters to develop. The coal is very black and said to show as high as 72 per cent. fixed carbon.

The firm formerly known as F. M. Hicks & Co., have recently become incorporated under the name of the Hicks Locomotive & Car Works of Chicago Heights, Ill. The officers of the new concern are: J. M. Hicks, President; Elliott C. Smith, Vice-President; Wm. McInnes, Treasurer; and E. Hope Norton, Assistant Treasurer. All departments of the business are now carried on by the Hicks Locomotive & Car Works, with increased capital and enlarged facilities.

The firm formerly known as F. M. Hicks & Co., have recently become incorporated under the name of the Hicks Locomotive & Car Works of Chicago Heights, Ill. The officers of the new concern are: J. M. Hicks, President; Elliott C. Smith, Vice-President; Wm. McInnes, Treasurer; and E. Hope Norton, Assistant Treasurer. All departments of the business are now carried on by the Hicks Locomotive & Car Works, with increased capital and enlarged facilities.

## Recent 4-6-2 Engine for the B. &amp; O.

Concerning some engines purchased in recent years by the Baltimore & Ohio Railroad, Mr. J. E. Muhlfeld, general superintendent of motive power, wrote:

"The most recent acquisition is 35 Pacific type passenger steam locomotives having a total weight each of 229,500 lbs., without tender, distributed over a total wheel base of 34 ft. 3½ ins., with 150,500 lbs. on a rigid wheel base of 13 ft. 2 ins., over six 74 in. diameter driving wheels. They have a calculated tractive power of about 31,100 lbs. and the capacity required to haul 970 tons in freight cars at a speed of 10 miles per hour on a 1 per cent. grade. These passenger locomotives, built at the Schenectady shops of the American Locomotive Company, are now in regular service, and haul without a helper, through passenger trains consisting of 1 baggage, 1 postal, 2 vestibule coaches, 1 dining, 3 sleeping and 1 observation parlor car, or a total of 9 cars, approxi-

Our illustration gives a good idea of the general design and proportions of these 4-6-2 machines, which are of the largest and most powerful type for the class of service, now in existence. They were particularly designed for the handling of heavy through passenger trains at the required speeds over level and mountainous, open and tunneled railroad, of varying curvature and gradient.

The engines are simple, with 22x28 in. cylinders, and with the wheels and weight on drivers already given, the ratio of tractive power to adhesive weight is as 1 is to 4.8. The valves are of the piston type actuated by direct motion. The driving wheels are all flanged and they are evenly spaced, the center one being the main driver. The spring gear is overlung with equalizers between the frame bars, and jointed hangers. The carrying wheels at the rear are 50 ins. in diameter with outside journal bearings and the weight on

Wheel Base—Total, engine and tender, 65 ft. 3½ ins.

Weight—In working order, 229,500 lbs.; on drivers, 150,500 lbs.; engine and tender, 369,800 lbs.

Axles—Driving journals, main, 10x13 ins.; others, 9½x13 ins.; engine truck journals, diameter, 6½ ins.; length, 12 ins.; trailing truck journals, diameter, 8 ins.; length, 14 ins.; tender truck journals, diameter, 5½ ins.; length, 10 ins.

Fire Box—Type, wide; length, 108½ ins.; width, 75¼ ins.; thickness of crown, ¾ in.; tube, 7½ in.; sides, ¾ in.; back, ¾ in.; water space, front, 4½ ins.; sides, 4½ ins.; back, 4½ ins.

Crown Staying—Radial.

Air Brake—Pump, 11 ins.; reservoirs, two,—18½x120 ins.

Engine Truck—Four wheel swing center.

Trailing Truck—Radial, with outside journals.

Piston—Rod diam., 3½ ins.

Tender Tank—Style, water bottom.

Main Valves—Type, piston; travel, 6 ins.; steam lap, 1 in.; exhaust clearance, ½ in.

Setting, ¼ in. lead at 7-inch cut-off, front and back.

Wheels—Engine truck, diam., 37 ins.; kind, cast iron spoke; trailing truck, diam., 50 ins.; kind, cast steel spoke; tender truck, diam., 37 ins.; kind, cast iron plate.

The General Electric Company, which established its main office in the Union

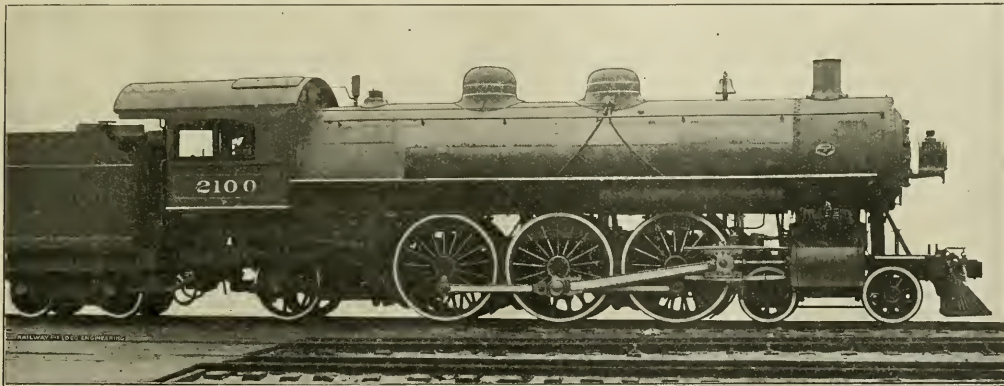

FAST PASSENGER 4-6-2 ENGINE FOR THE B. & O.

J. E. Muhlfeld, General Superintendent of Motive Power.

American Locomotive Company, Builders.

mating 425 tons, for a distance of 31.6 miles from Cumberland, Md., to Manila, Pa., in 63 minutes. The town of Manila is near the crest of the Allegheny Mountains, and the total rise in altitude is 1,588 ft. This distance is made up of an average gradient of .4 per cent. between Cumberland and Hyndman, a distance of 13.9 miles, and of 1.4 per cent. between Hyndman and Manila, a distance of 17.6 miles. The maximum work done in this distance, consists of 6.1 miles run on a 1.5 per cent. grade with 8 degs. reverse curvature between Roddy and Manila, and a 1.5 mile run on a 1.93 per cent. grade. These engines are also hauling passenger trains consisting of 11 cars weighing about 500 tons. They start from a dead stop and run for a distance of 7 miles on a 1 per cent. grade, with from 1 to 8½ degs. curvature, and they do it in 14½ minutes.

them is equalized with the rear drivers.

The boiler is a straight top one, the first ring of which is 72 ins. in diameter. The heating surface is 3,417.6 sq. ft. in all, of which 183 sq. ft. is in the fire box. The total heating surface is equal to a square whose sides is about 58½ ft. long. The grate area is 56½ sq. ft. The heating surface is therefore 60.48 times the amount of grate area. The tubes in this boiler are 2¼ ins. in diameter. There are 276 of them and they are each 20 ft. long. The steam pressure carried is 200 lbs. The back sheet slopes 20½ ins. forward from the line of the mud ring.

The tender frame is made of 13 in. steel channels and plates and the water capacity of the tank is 7,000 U. S. gallons, twelve tons of coal is carried. The headlight is placed almost in the center line of the smoke box. The principal dimensions are as follows:

Savings Bank Building at Oakland, Cal., immediately after the San Francisco disaster, as well as a local office at 1759 Geary street, in the burned city, has already leased a suite of rooms in the new Monadnock Building, which they expect to occupy in June, 1907. For handling the present business, a half a block of land has been leased in Emeryville in close proximity to both the Santa Fe and Southern Pacific Railroad tracks. A temporary building is now about completed on this land for taking care of stock, and work has already been started on a new warehouse, containing about 80,000 sq. ft., which will be located at the south end of the block, bounded by Kansas, Rhode Island, 15th and Alameda streets. Cars are being shipped from the company's factories so that the stock at San Francisco will soon be complete. At present the company is in condition to fill orders as rapidly as before the fire.

### Locomotive Front Ends.

The committee appointed by the Master Mechanics' Association to deal with what we may call the Front End problem, consisted of Mr. H. H. Vaughan, chairman, and Messrs. F. H. Clark, Robert Quayle, A. W. Gibbs, W. F. M. Goss, and G. M. Basford. The report presented at the June meeting held at Atlantic City, N. J., was substantially as follows:

The tests have been made under the direct supervision of Prof. W. O. Teague, Assistant Professor of Experimental Engineering, whose report covers all details of the tests. It is the understanding of your committee also that Prof. Teague has been enthusiastically assisted by Mr. L. E. Endsley, Instructor in the Engineering Laboratory in charge of the locomotive testing plant. To these as well as to others, too numerous to mention, your committee respectfully acknowledges its indebtedness and returns its thanks.

#### OUTSIDE STACKS.

The tests of outside stacks involved two different heights, namely, 29 ins. and 47 ins. The 29-in. height only is practicable for road conditions upon the locomotive under test. Stacks of each of these heights were supplied in diameters ranging from 15 ins. to 21 ins. by 2-in. steps and as the work proceeded it seemed desirable to extend the range with the result that in the 29-in. height, stacks of 23 ins. and 25 ins. diameter respectively were added to the series. In these tests no draft pipes or netting were employed in the front end; the diaphragm and exhaust pipe were the only details present. Under these conditions, with a 29 in. height, the best diameter was found to be 23 ins., though this was not much better than that of 21 ins. With a 47 in. height the best diameter is 21 ins. The exact arrangement of equipment for the best results is shown by Figs. 1 and 2. The notation under these figures and under those which immediately follow, gives the draft obtained with a constant back pressure of 3.5 lbs. It will hereafter appear that there are better arrangements than that shown by Fig. 1. The point which is proven is that, assuming a plain outside stack 29 ins. high to be used, its diameter for the best results is 23 ins., as given.

#### COMPARISON OF RESULTS OBTAINED FROM A LARGE LOCOMOTIVE WITH THOSE PREVIOUSLY OBTAINED FROM A SMALLER LOCOMOTIVE.

Among the more important conclusions drawn from the American Engineer's tests of 1903, the following are of especial interest in connection with the present discussion:

1. That for a tapered stack, the

diameter for best results does not change with changes in height.

2. That the diameter of stack is somewhat affected by the height of the exhaust tip, the diameter for the best results being greater as the nozzle tip is lowered.

3. That, calling  $d$  the diameter of the stack at its smallest part, and  $D$  the diameter of the front end, the relation between the diameter of stack and front end when the exhaust tip is at the center of the boiler is

$$d = .25D.$$

4. That the diameter of stack must, for best results, be increased .16 in. for each inch that the exhaust tip is below the center line of the boiler; that is, calling  $h$  the distance between the center line and the tip,

$$d = .25D + .16h.$$

5. That a variation of an inch or less from the diameters given by the equation will produce no unfavorable results.

In view of the publicity that has been given these statements, it is important to determine the extent to which their truth is affected by the experiments of the present year.

As to the necessity for varying the diameter with the height of stack, the work of the past year is far less elaborate than that of 1903, but two heights of stack having been employed, namely, those of 29 ins. and 47 ins. respectively. Comparing draft values obtained from stacks of each of these heights under a uniform back pressure of 3.5 lbs. (Series 3 and 4, Fig. 10), it appears that the best diameter for the 29 in. stack is 23 ins. The best results from the 47 in. stack were obtained by use of the largest diameter experimented upon (21 ins.). Curves plotted through the several points (Series 4, Fig. 10) show this diameter to approach that for the maximum draft, but it does not equal it. The indication is that if a diameter of 23 ins. had been employed it would have been found right for the 47 in. height as well as for the 29 in. height. There is in fact nothing in the experiments of the present year to invalidate the conclusion derived from the preceding work. So far as outside stacks are concerned, therefore, the diameter does not need to be varied when the height is changed.

As to the effect upon the proportion of stack resulting from changes in the height of the exhaust tip, it must be noted that the work of the present year has involved one height of tip only and hence gives no information upon this question. The validity of the conclusion already stated, however, has never been called in question and it may be assumed to stand.

Concerning the actual size of the stack for best results, the work of the present year points to the desirability of us-

ing diameters which are somewhat larger than those given by the equation of 1903. This equation is,

$$d = .25D + .16h.$$

which when applied to the N. Y. C. locomotive experimented upon gives  $d = .25 \times 74 + .16 \times 12.5 = 18.5 + 2.0 = 20.5$ ,

whereas, with a stack 29 ins. high the best results were actually obtained when the diameter was 23 ins. The difference of 2.5 ins. is not great, especially in view of the fact that it has been distinctly noted that variation of an inch even more is not important. The difference is to be accounted for also by the fact that in reviewing the results of 1903 there was a common feeling on the part of the members of the advisory committee that the experiments pointed to dimensions which, for service conditions, were excessive. Because of this view, the equation was framed as a conservative expression of the experimental results. The data obtained during the present year might, for like reasons, be similarly treated, in which case the discrepancy of 2.5 ins. would be diminished or even be eliminated. Since, therefore, the only element of doubt concerning the results of 1903 has found expression in beliefs that they gave diameters which were too large, it is the feeling of your committee that the work of the present year may be accepted as a full confirmation of the earlier work.

Having shown the value of the work of the present year in confirming the conclusions of 1903, it remains to consider those phases of the present year's work which are to be regarded as extending beyond the scope of the earlier investigations; the effect of which necessarily diminishes the importance of that which has preceded. It will be shown that, however well the plain outside stack may be proportioned, the demands of service require it to give way to a more highly articulated device.

#### INSIDE STACKS.

The experiments included inside stacks of four different diameters ranging from 15 ins. to 21 ins., a constant outside height of 29 ins. and a penetration into the smoke box of 12 ins., 24 ins. and 36 ins., respectively. The best proportions of this form of stack is such that its diameter is 21 ins. and its penetration (P) into the smoke box is 12 ins. Results of nearly the same value were, however, obtained with stacks of smaller diameter having greater penetration. This may well be seen by reviewing the draft values obtained in return for a back pressure of 3.5 lbs., as given in Series 5, 6 and 7. Thus, 21 ins. diameter, 12 ins. penetration gave a draft of 4.71; 19 ins. diameter, 24 ins. penetration gave a draft of 4.55, and 17 ins. diameter, 26



ins. penetration gave a draft of 4.32. From values thus presented it appears that as the degree of penetration increases the diameter of stack should be reduced. The effect is, in fact, of the same nature and degree as that which results from raising the exhaust tip. It is noteworthy also that these values for the plain inside stack are not materially better than those for the plain outside stack, a fact which was formulated as a conclusion resulting from the work of 1903.

#### INSIDE STACK WITH FALSE TOP.

It had been planned to fit the front end with three different false tops located at 12 ins., 24 ins. and 36 ins. respectively from the top of smoke box, but the presence of the steam pipes made it difficult to fit the 12 in. top and as a consequence only the 24 in. and 36 in. drops were experimented upon. In each case stacks of different diameters were used, the outside height being always 29 ins. These arrangements and the draft resulting therefrom, when the back pressure was 3.5 lbs., are shown by Series 8 and 9. The best results were obtained with a stack 17 ins. in diameter having a penetration of 24 ins. In all cases with the false top the 17 in. stacks gave best results. A comparison of these results with those quoted for plain outside stack and for plain inside stack show material improvement in draft values.

#### SUBSTITUTES FOR FALSE TOP.

The false top necessarily interferes with free access into the front end which fact makes it desirable that a way be found in which to secure the results derived from it by means which are more simple. It was suggested that experiments be made to determine the effect upon the plain inside stack of an annular ring or flange which might be considered as representing a portion of the false top. Responding to this suggestion rings of two diameters were used on 17 in. and 19 in. stacks having a penetration of 24 ins. It was found that the proportions gave substantially the same results as those obtained with the best arrangement of false top. Believing that the results thus obtained pointed to the desirability of having a broader curve at the base of the stack and that when the proper proportions were understood the best results would be obtained from such a curved surface, the 17-in. stack was fitted with a bell to which, for purposes of experimentation, flanges of various widths were afterward added, with the result that those proportions proved most satisfactory. These arrangements and the draft values obtained in connection therewith, are shown by Series 12, 13 and 14. It will be noted that the best draft with

the false top was 5.06; with the ring 5.05, and with the bell 4.98—that is, these three arrangements are practically on an equality. No other arrangements were experimented upon which gave higher draft values than these.

#### SINGLE DRAFT PIPES.

Draft pipes of various diameters, adjusted to many different vertical positions, were tested in connection with plain stacks of the several diameters available. The elaboration of this phase of the work was very extensive. It was found that for the best results the presence of a draft pipe requires a smaller stack than would be used without it, but, that no possible combination of single draft pipe and stack could be found, which gave a better draft than could be obtained by the use of a properly proportioned stack without the draft pipe. While the presence of a draft pipe will improve the draft when the stack is small, it will not do so when the stack is

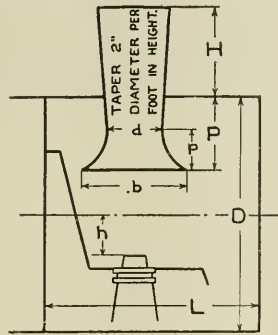

FIG. 9. ARRANGEMENT OF FRONT END RECOMMENDED IN REPORT.

sufficiently large to serve without it. The best proportion and adjustment of single draft pipe and stack are shown by Fig. 4 in the report. The arrangement of draft pipes covered by the experiments and the draft resulting therefrom are shown by Series 16 to 69.

#### DOUBLE DRAFT PIPES.

Double draft pipes of various diameters and lengths, and having many different positions within the front ends, all in combination with stacks of different diameters, were included in the experiments with results which justify a conclusion similar to that reached with reference to single draft pipes. Double draft pipes make a small stack workable. They can not serve to give a draft equal to that which may be obtained without them, provided the plain stack is suitably proportioned. The arrangements and proportions giving the best results are those shown by Fig. 5 in the report and the different arrangements employed with the draft values resulting by Series 70 to 87.

#### THE LENGTH OF FRONT END.

The experiments involving different lengths of front end only, appear to be inconclusive. The range of these experiments included the length of the front end normal to the locomotive which is 65.75 ins., with successive reductions therefrom of  $4\frac{1}{2}$  ins.,  $8\frac{1}{8}$  ins. and 20 ins. respectively, obtained in each case by fitting in a false front. The fitting was well done, the work being made practically tight, notwithstanding which fact it was found that the longest and shortest ends experimented with gave practically identical results, while the lengths between these limits gave results which were somewhat inferior. The peculiar character of the results as first obtained led to a complete duplication of the work after a considerable interval had elapsed, with results which were identical with those first obtained. So far as the experimental results give a solution to this problem, they point to a length of 66 ins. or 46 ins. as equally satisfactory, and suggest that intermediate lengths are to be avoided. The arrangements employed and the draft values resulting appear as Series 15. SUGGESTION AS TO A STANDARD FRONT END is presented as Fig. 9, which, with the following equations referring thereto, may be accepted as a summary of the conclusions to be drawn from all experiments made.

For best results, make  $H$  and  $h$  as great as practicable.

Also make

$$d = .21D + .16h.$$

$$b = 2d \text{ or } .5D.$$

$$P = .32D.$$

$$p = .22D.$$

$$L = (\text{not well established}).$$

$$= .6D \text{ or } .9D, \text{ but not of intermediate values.}$$

While the drawing is a simple one, to be put forth as a result of so elaborate a series of experiments, it goes without saying that the latter have been valuable quite as much for the things they prove useless as for the proportions of details which they serve to define. For example, it will be seen that the suggested standard does not include draft pipes, and that it includes a stack of comparatively large diameter having a bell at the lower end of dimensions quite beyond those now common in American practice.

#### A SUMMARY OF ALL RESULTS.

To make comparisons easily possible, the draft obtained when the back pressure equals 3.5 lbs. has been taken from curves presented elsewhere, and combined with a drawing showing the arrangements to which they apply. These summarized statements are presented herewith as Figs. 10 to 19, in the report. By their aid one may familiarize himself with the extent and significance of the experiments. For purposes of the

laboratory, each different arrangement was given a series number, and in the summary reference to this number appears within a circle at the upper left-hand corner. The following is a brief key to the diagrams:

- Series 1—29 in. stacks of different diameters, draft pipes and diaphragm normal to the engine.  
 Series 2—Same with draft pipes removed.  
 Series 3—Same with draft pipes and extension diaphragm removed.  
 Series 4—47 in. stack of different diameters.  
 Series 5—7—Plain inside stacks.  
 Series 6—9—False tops.  
 Series 10—False top with diaphragm normal to engine.  
 Series 11—Annular rings upon base of stacks.  
 Series 12-14—Stacks having bell-shaped base.  
 Series 15—Variable lengths of front end.  
 Series 16-21—13 in. single draft pipe in combination with 15 in. stacks.  
 Series 22-27—13 in. single draft pipe in combination with 19 in. stacks.  
 Series 28-33—13 in. single draft pipe in combination with 23 in. stacks.  
 Series 34-39—15 in. single draft pipe in combination with 15 in. stacks.  
 Series 40-45—15 in. single draft pipe in combination with 19 in. stacks.  
 Series 46-51—15 in. single draft pipe in combination with 23 in. stacks.  
 Series 52-57—17 in. single draft pipe in combination with 15 in. stacks.  
 Series 58-63—17 in. single draft pipe in combination with 19 in. stacks.  
 Series 64-66—17 in. single draft pipe in combination with 23 in. stacks.  
 Series 70-72—13 in. and 15 in. draft pipes in combination with 15 in. stacks.  
 Series 73-75—13 in. and 17 in. draft pipes in combination with 15 in. stacks.  
 Series 76-78—13 in. and 15 in. draft pipes in combination with 19 in. stacks.  
 Series 79-81—13 in. and 17 in. draft pipes in combination with 19 in. stacks.  
 Series 82-84—13 in. and 15 in. draft pipes in combination with 23 in. stacks.  
 Series 85-87—13 in. and 17 in. draft pipes in combination with 23 in. stacks.

A more elaborate presentation of methods and results is given in the accompanying appendix.

#### DISPOSITION OF EQUIPMENT.

The experimental equipment of stacks and draft pipes employed in the tests has been left in the keeping of the University. It is the understanding of your committee that the material will, for a time at least, be preserved in the locomotive museum, though it is possible that the demand for room may eventually require them to be scrapped. So far as your committee is concerned, they are disposed of.

#### AN EXTENSION OF COURTESY TO THE NEW YORK CENTRAL LINES.

At the conclusion of its formal work and with the co-operation of the University authorities, your committee undertook and completed a minor investigation under the direction of the New York Central Lines, the results of which have been reported directly to Mr. J. F. Deems, General Superintendent of Motive Power. The opportunity thus embraced whereby courtesy was shown the Railroad Company, permitted your committee to make some slight return for the assistance rendered the Associa-

tion by the New York Central Railroad Company.

#### Staten Island Rapid Transit Notes.

Since the re-establishment of the Staten Island Rapid Transit Railway, the phenomenal growth of the watering places that cluster around the beautiful island bids fair in a few years to surpass their rivals in the vicinity of New York. The rush of visitors is now larger than ever, and the number of locomotives in use are being increased. There are now about forty in the service

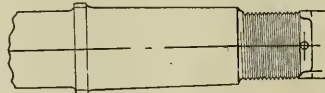

PISTON ROD, S. I. R. T. RAILROAD.

of the company, and those that have been built at the company's shops at Clifton are doing double service and show how excellently adapted they are for the work. The engines were built on plans furnished by Mr. J. H. Clark, chief engineer and master mechanic, and his adaptation of the Wooten fire box has in a few years already saved the price of the engines in coal. Mr. John O'Connor, the shop foreman, has ably supplemented Mr. Clark in keeping the mechanical department in the highest state of efficiency. Not one accident of a serious kind has occurred during the season. The fracture of a piston rod on one of the locomotives set Mr.

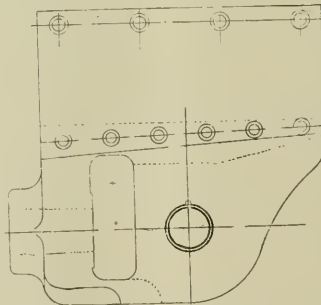

CROSSHEAD USED ON S. I. R. T. RAILROAD.

O'Connor to work on a method of strengthening the piston and crosshead connection, and we take pleasure in reproducing his improvement.

As will be seen from the annexed illustration, the piston is taper-fitted in the usual way, but is held in place by a nut in a recess in the crosshead. There is a collar  $\frac{3}{8}$  in. in width on the piston rod, where it abuts against the crosshead, the collar being filleted on both sides. The liability to break at the shoulder is thereby entirely avoided and the improvement is worthy of general

adoption. No keyway is necessary and an adjustable ring readily fills up the increased inner opening of the piston gland, and a series of notches on the nut at the end of the piston rod renders it ready of access to a spanner wrench. The nut is held in place by a cotter pin.

#### M. C. B. and M. M. Officers:

The officers elected by the Master Car Builders' Association at the fortieth annual convention, for the year 1906-7 are as follows: President, Mr. M. E. Fowler, of the Canadian Pacific Railway; vice-president, Mr. G. N. Dow of the Lake Shore & Michigan Southern; second vice-president, Mr. R. F. McKenna of the Delaware, Lackawanna & Western; third vice-president, Mr. R. W. Burnett of the Erie Railroad; treasurer, Mr. John Kirby.

The executive committee is composed of the gentlemen named above and also Messrs. J. F. Walsh, F. N. Hibbits and F. T. Hyndman.

The officers elected by the American Railway Master Mechanics' Association at their thirty-ninth annual convention, for the year 1906-7 were: President Mr. J. F. Deems of the New York Central; vice-president, Mr. Wm. McIntosh of the Central Railroad of New Jersey; second vice-president, Mr. H. H. Vaughan of the Canadian Pacific; third vice-president, Mr. G. W. Wildin of the Erie; treasurer, Mr. Angus Sinclair, editor of RAILWAY AND LOCOMOTIVE ENGINEERING.

In addition to these gentlemen who are ex-officio members of the executive committee, Messrs. F. H. Clark (C. B. & Q.), J. F. Walsh (C. & O.), C. A. Seley (C. R. I. P.), F. M. Whyte (N. Y. C.) and A. E. Mitchell were also elected members of this committee. Mr. Joseph W. Taylor is the permanent secretary of both associations. His address is 390 Old Colony Bldg., Chicago, Ill.

#### New Canadian Railway.

A prospectus has been issued by the Central Railway of Canada. The road will extend from Midland on the eastern shore of Georgian Bay, on the Great Lakes, to the seaport of Montreal, a distance of 344 miles, which with extensions and branches will bring the total mileage up to about 660 miles. The company have already purchased the Ironclad Bancroft and Ottawa Railway, of which 47 miles are constructed, and are being profitably worked. The work will be pushed with great energy and is expected to be completed in two years.

It is better to die of hunger, having lived without grief, and fear, than to live with a troubled spirit amid abundance.—*Epictetus*.

# Of Personal Interest.

Mr. James L. Pilling has severed his connection with the Quincy, Manchester, Sargent Company of New York.

Mr. Thos. C. Halsey has accepted position with the Baldwin Locomotive Works, at Philadelphia, Pa., as traveling engineer.

Mr. Webb C. Ball has been appointed general time inspector of the Lehigh Valley Railroad, with headquarters at South Bethlehem.

Mr. H. A. Hoke has been appointed assistant engineer in the office of the mechanical engineer of the Pennsylvania, at Altoona, Pa.

Mr. J. Stonehouse has been appointed general foreman of the Chicago & Northwestern shops at Huron, S. D., vice Mr. A. Adams, resigned.

Mr. W. E. Fowler, who has been elected president of the Car Builders' Association, for the year 1906-7 has had considerable experience as a car builder. He entered the railway service in 1880 with St. L. I. M. & S. Ry. at Baring Cross, Ark. In September, 1882, he entered the service of the U. P. Ry. at Denver, and was foreman of the extensive repair shops there until July, 1893. He was appointed master car builder of the Colo-

Mr. A. T. Hardin has been promoted from assistant to the general manager of the New York Central R'd., to assistant general manager.



H. F. BALL,  
Superintendent of Motive Power, L. S. & M. S.  
The Retiring President of the Master  
Mechanics' Association.

Mr. George Tier has been appointed foreman of the Chicago, Rock Island & Pacific at McFarland, Kan., vice Mr. R. A. Huey, assigned to other duties.

Mr. R. D. Gibbons has been appointed master mechanic of the Monterey division of the Mexican Central Railway, vice Mr. Geo. W. Cooper, resigned.

Mr. H. A. Gillis, who has been for the last nine years superintendent of the Richmond Locomotive Works, now one of the shops of the American Locomotive Company, has resigned to accept the position of general manager of the Autocar Company, of Ardmore, Pa. The Autocar Company are certainly to be congratulated on securing the services of Mr. Gillis, for he has been regarded in railway circles as the ablest shop manager in the field. He combines in a happy connection the working machinist and the scientific mechanical engineer. He is a graduate of the U. S. Naval Academy, where he received an excellent scientific education. From that he entered a railroad shop, worked as a machinist, rising through the steps of gang foreman, shop foreman, general foreman and master mechanic. Then the managers of the Richmond Locomotive Works, perceiving the ability of Mr. Gillis, engaged him as shop superintendent, in which position he achieved enviable success.

Mr. E. K. Woodward, principal assistant engineer of the Wabash, has been appointed chief engineer of the Pere Marquette, vice Mr. J. F. Deimling, resigned.

Mr. F. L. Blendinger, purchasing agent of the Lehigh Valley Railroad, will hereafter have charge of the purchase of all fuel coal for that company.

Mr. R. L. Uzzell, assistant to the president of the Georgia, Florida & Alabama, has been appointed purchasing agent of that road with office at Bainbridge, Ga.

Mr. S. E. Kildoyle, formerly master mechanic of the Southern Pacific at Guaymas, Mex., has been appointed master mechanic of the Mexican Central at Mexico City, vice Mr. L. Strom, resigned.

Mr. J. F. Deems, general superintendent of motive power, rolling stock and machinery of the New York Central Lines, has been elected president of the American Railway Master Mechanics' Association for the year 1906-7. Mr. Deems began railroad work as an apprentice on the B. & O. Some years later he entered the service of the Chicago, Burlington & Quincy and worked his way up on the "Q" through the positions of gang



W. E. FOWLER.

rado & Southern at Denver, and remained in the employ of that company until 1900, when he accepted a similar appointment on the Southern Pacific Railway at Sacramento, Cal. In April, 1902, Mr. Fowler was appointed to his present position as master car builder on the Canadian Pacific Railway at Montreal, Canada.



J. F. DEEMS.

foreman, roundhouse foreman, general foreman, master mechanic, and assistant superintendent of motive power. After this he became superintendent of the Schenectady shops of the American Locomotive Company, which position he left to take the chief executive position in the motive power department of the Vanderbilt Lines.

Mr. Adrian H. Joline has been elected Chairman of the Board of Directors of the Missouri, Kansas & Texas Railway Company, vice Mr. Henry C. Rouse, deceased.

Mr. F. K. Tutt has been appointed acting master mechanic of the St. Louis Iron Mountain & Southern, with office at Van Buren, Ark., vice Mr. H. K. Mudd, resigned.

Mr. L. C. Rost has been appointed master mechanic of the Des Moines, Iowa Falls & Northern, with headquarters at Iowa Falls, Ia., vice Thomas D. McDonald, deceased.

Mr. G. C. Bishop has been appointed superintendent of motive power and equipment of the Long Island Ry., with office at Richmond Hill, N. Y., succeeding Mr. Phillip Wallis.

Mr. J. T. Walsh, heretofore master mechanic of the Corvallis & Eastern Ry., with office at Albany, Ore., has been appointed superintendent of that road, vice Cornelius Sullivan, deceased.

Mr. Webb L. Gibbs has been appointed road foreman of equipment of the St. Louis & San Francisco; and of the Texas, Ft. Worth & Rio Grande (Frisco System), with headquarters at Ft. Worth, Texas.

Mr. W. L. Harrison, master mechanic of the Chicago, Rock Island & Pacific Ry. at Horton, Kan., has been appointed acting superintendent of motive power at Chicago, Ill., succeeding Mr. J. P. Kilpatrick.

Mr. J. M. Drury, heretofore division master mechanic of the Atchison, Topeka & Santa Fe Coast Lines at Winslow, Ariz., has been transferred to Raton, N. M., in a similar capacity, vice Mr. S. W. Mullinix, resigned.

Mr. W. E. Woodhouse, heretofore road foreman of engines, of the Canadian Pacific Ry., 4th district, Central division, has been appointed District Master Mechanic of the same district, with headquarters at Moose Jaw, Sask.

Mr. H. S. Wall, heretofore division foreman at Barstow, Cal., on the Atchison, Topeka & Santa Fe Coast Lines, has been appointed division master mechanic of the same road at Winslow. He succeeds Mr. Drury, transferred.

Mr. H. M. Large, heretofore assistant master mechanic of the Erie and Ashtabula divisions of the Pennsylvania Lines, has been appointed master car builder of the Southern division of the Grand Rapids & Indiana, with office at Grand Rapids, Mich.

Mr. F. Newton has been appointed Master Mechanic of the Sterling division of the Chicago, Burlington & Quincy Railway lines west of the Missouri River, with headquarters at Ster-

ling, Col. He was formerly road foreman of engineers.

Mr. F. M. Woodall, general yard master of the Central Ry. of Georgia, at Atlanta, has been promoted to train master of the Macon division, vice Mr. M. A. Ramsey, transferred to Atlanta, Ga., as general yard master. Mr. Woodall will be located at Macon.

Mr. E. M. Merriwether, engineer of maintenance of way at Moberly, Mo., on the Washash, has been appointed principal assistant engineer, with office at St. Louis, Mo., succeeding E. K. Woodward, resigned. Mr. J. T. Sheahan, master carpenter at Moberly, succeeds Mr. Merriwether.

Mr. C. E. Schaff, in addition to his duties as vice-president, will continue as the general manager of the Cleveland, Cincinnati, Chicago & St. Louis, the Peoria & Eastern and the Cincinnati Northern, with title of vice-president and general manager, and office in Chicago.

Mr. John T. Carroil has been appointed general foreman of the locomo-



"THREE OF A KIND"—ATLANTIC CITY.

tive department of the Lake Shore & Michigan Southern at Elkhart, Ind., vice Mr. O. Antz, who has been appointed inspector of engines of the New York Central Lines, at the works of the American Locomotive Co. at Dunkirk, N. Y.

Mr. Charles F. Smith, assistant general superintendent of the New York Central, has been appointed general superintendent in charge of freight traffic east of Albany, and passenger traffic for the entire line, and Mr. P. E. Crowley, also assistant general superintendent of the same road, has been appointed general superintendent of freight traffic west of Albany.

Mr. J. P. Bradfield, heretofore general superintendent of the New York Central & Hudson River Railroad, has been appointed general manager of that road, with headquarters at New York, vice Mr. A. H. Smith, promoted. Mr. Bradfield was formerly general superintendent of the New York, Ontario & Western Ry., leaving that road to become superintendent of the western division of the New York Central at Buffalo. He was appointed assistant

general superintendent of the latter road, and was made general superintendent later on.

Dr. W. K. Hatt has been appointed professor of Civil Engineering at Purdue University at Lafayette, Ind., vice Prof. W. D. Pence. Professor Hatt has been identified with Purdue University since 1893. He graduated from the University of New Brunswick in the Arts Course in 1887, and from Cornell University in Civil Engineering in 1891. He has had a varied experience in the practice of civil engineering along different lines, particularly in railroad location, construction and maintenance, chiefly on the Intercolonial Railroad of Canada. He served two years as Town Engineer of West Lafayette, Indiana, and since 1903 has been in charge of the Timber Tests of the Forest Service, United States Department of Agriculture. Under his direction a programme of investigation was mapped out in 1903 and has since been executed at laboratories established at Yale University, Purdue University, the Universities of California, Washington and Oregon, and in a laboratory at Washington, D. C. That the Purdue Laboratory for Testing Materials may continue to have the benefit of Professor Hatt's direction, its organization is to be incorporated with that of the School of Civil Engineering. Professor Hatt will also continue to act as Consulting Engineer for the Forest Service, United States Department of Agriculture, Washington, D. C.

#### Obituary.

We regret to announce the death of R. W. Bushnell, of Cedar Rapids, Iowa, for many years master mechanic of the Burlington, Cedar Rapids & Northern shops in that city. Mr. Bushnell was in his seventy-sixth year, but of a fine physique, and hale and hearty. By an unfortunate fall from a ladder in his garden last month, his collar bone was fractured and he received other internal injuries from which he died. He was a native of Norwich, Conn., and learned engineering in the Rogers Locomotive Works. He moved West in 1853, and held several positions in the C. & N. W. Railway, and in 1868 entered the service of the company with which he was so long associated. His sudden death has occasioned much regret among railroad men, among whom he was widely known. Mr. Angus Sinclair, Editor of RAILWAY AND LOCOMOTIVE ENGINEERING, was for several years associated with Mr. Bushnell on the E. C. R. & N., and expresses his profound regret at the death of a good man, a delightful companion, and an accomplished mechanic and engineer.

**Patent Office Department.**

It is surprising that the number of mechanical devices aiming towards the perfection of the locomotive should apparently increase instead of diminish. It might properly be supposed that the

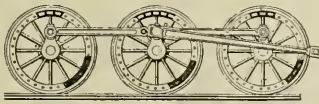

COUNTERBALANCE DEVICE.

mercurial ingenuity of the inventor had nearly reached its limit, but the increasing size of locomotives call for a constant modification of details, which, although not affecting the organic construction of the engine, give abundant scope to inventive genius. From the latest reports from the Patent office, it appears that boiler construction and methods of lubrication have engrossed much of the attention of the inventors and some selections from their work is presented.

**LOCOMOTIVE DRIVING WHEELS.**

Messrs. Allfree and Hubbell of Chicago, Ill., have patented a system of counterbalancing locomotive wheels. No. 819,199. As will be seen in the accompanying illustration, the device consists of having a hollow rim subdivided into a plurality of chambers, and means for retaining congealed molten lead or other metal in the chambers, the center of gravity of the weights being eccentric to the center of the wheel, and on the opposite side of the wheel from that of the crank pin hub.

**LOCOMOTIVE FURNACE.**

Messrs. Wade and Nicholson, Chicago, Ill., have secured a patent, No. 820,451, on a locomotive furnace. The fire box is of the usual type, but is provided with arch tubes that connect the front and rear water legs of the boiler, to which is added an arch of channeled bricks arranged beneath the arch tubes, the arch having passages communicating with air entrance tubes, which extend

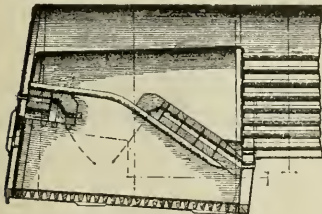

LOCOMOTIVE FURNACE.

through the rear water leg of the boiler. An arch of similar non-fusible material rests on the front tubes, and the bricks are so arranged that they can readily be removed to afford access to the boiler flue sheet.

**MECHANICAL STOKER.**

A mechanical stoking appliance has been invented and patented, No. 819,476, by Messrs. J. & T. Vicars, Earlestown, England, consisting of a casing enclosing the ash-pit of the furnace, a movable carriage connected to each end of the fire bar support, and reciprocating mechanism secured to the carriage, and packing devices to prevent the escape of air. The device is said to have been in successful operation for several years.

**LOCOMOTIVE EXHAUST MECHANISM.**

An improvement in exhaust mechanism has been patented, No. 821,402, by Mr. John Herron, Marquette, Mich., consisting of the combination of a locomotive provided with a main exhaust pipe connected with the cylinders, and an auxiliary exhaust connected with the main exhaust pipe in the smoke box, with mechanism for opening and closing

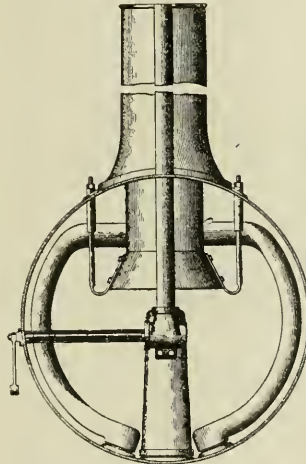

EXHAUST MECHANISM.

the auxiliary exhaust. The mechanism reaches the cab of the locomotive where the auxiliary exhaust may be operated as desired.

**LUBRICATING DEVICE.**

Mr. R. G. Woodward, Waukegan, Ill., has patented a lubricating device, No. 822,877, consisting of a hollow connecting rod forming a cylindrical receptacle for the lubricant and having an outflow opening to the part lubricated. The device is furnished with openings into the hollow space of the shaft and a cover for the openings.

**LUBRICATOR FOR ENGINE-VALVES.**

An apparatus for lubricating engine-valves has been patented, No. 823,349, by Mr. D. Morehouse, St. Elmo, Ill. The valve seat is provided with outlets in its face near the outer side of the inlet ports, and are so arranged that

both outlets will be covered by the valve during the middle part of its stroke, and alternately covered and uncovered by the valve at the ends of its stroke, so that the oil from the outlets will be car-

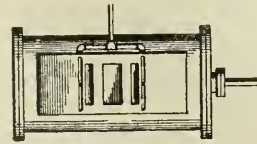

VALVE OILING DEVICE.

ried through the ports into the cylinder. Means are attached to supply oil to the outlets.

**JOURNAL LUBRICATOR.**

Mr. Charles H. Turner, New York, N. Y., has patented a journal lubricator, No. 819,475. The journal-box is furnished with a base plate resting on the bottom of the box, there being upwardly extending flanges on opposite sides of the plate with bearings and a shaft carrying rollers that convey the oil from the bottom of the box to the journal.

**A New Steel.**

A new alloy steel for the barrels of sporting guns has been undergoing tests before the Iron and Steel Institute of London, England. The steel which costs only a little more than ordinary good cast steel is subjected to great pressure while still in a fluid state in the mold. The elastic limit exceeds 60,000 lbs.; the breaking strain is 110,000 lbs.; the elongation being 30 per cent. in an 8 in. piece. The steel is manufactured by Messrs. Jessup and Sons, who have made a specialty of fluid compression.

The zebra is found only in Africa, where it inhabits the more rugged and remote mountain ranges of Abyssinia and Central Africa.

A readiness to believe ill without examination is the effect of pride and laziness. We are willing to find people

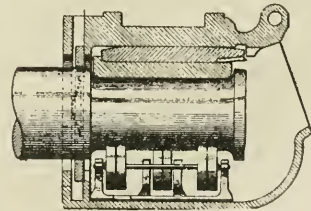

JOURNAL LUBRICATOR.

guilty and unwilling to be at the trouble of examining into the accusation.

In all things throughout the world, the men who look for the crooked will see the crooked, and the men who look for the straight will see the straight.—Ruskin.

### Baltimore & Ohio Motive Power.

During the past three years the Baltimore & Ohio Railroad have put into service several of the most powerful designs of steam and electric locomotives for freight, passenger and switching service, that have been recently built.

Among these are the Mallet type mountain helper steam locomotive, the total weight, without tender, of 334,500 lbs. being distributed over twelve 56 in. diameter driving wheels, having a total flexible wheel base of 30 ft. 8 ins. and a rigid wheel base of 10 ft. 0 in. This locomotive has a tractive power of 74,000 lbs. in compound, and 84,000 lbs. when working simple. It has a capacity which enables it to haul 2,200 tons in freight cars at a speed of 10 miles per hour on a 1 per cent. grade.

The new Consolidation or 2-8-0 type of fast through freight steam locomotives, have a total weight, without tender, of 208,500 lbs. distributed over a wheel base of 25 ft. 7 ins., and a weight of 185,000 lbs. distributed over eight 60 in. diameter driving wheels, on a rigid wheel base of 16 ft. 8 ins. These

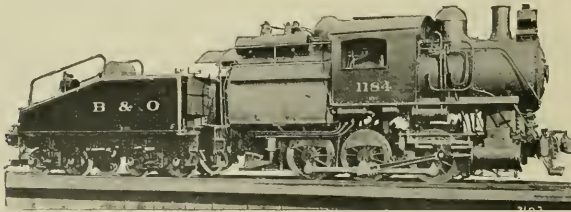

SIX-WHEEL SWITCHING ENGINE ON THE B. & O.

locomotives have a tractive power of 42,000 lbs. and a capacity sufficient to haul 1,180 tons in freight cars at a speed of 10 miles per hour on a 1 per cent. grade.

The six-wheel type of switching steam locomotives have a total weight, without tender, of 161,000 lbs. distributed over a total and rigid wheel base of 11 ft. on six 52 in. diameter driving wheels. These locomotives have a tractive power of 29,700 lbs. and capacity to haul 720 tons in freight cars at a speed of 10 miles per hour on a 1 per cent. grade.

The two-section freight helper electric locomotives, one of which is here illustrated, have a total weight of 320,000 lbs. distributed over a total flexible wheel base of 44 ft. 2 3/4 ins., with a rigid wheel base of 14 ft. 6 3/4 ins. The total weight is distributed over sixteen 42 in. diameter driving wheels, which gives these locomotives a total tractive effort, at full working load on eight motors, of 70,000 lbs. and the capacity necessary for hauling 2,200 tons in freight cars at a speed of 10 miles per hour on a 1 per cent. grade.

Two two-unit type of passenger helper electric locomotives, which have been in service for the past ten years, also compare most favorably with the more recent designs of passenger electric locomotives put into service and undergoing construction for modern terminal requirements. These locomotives have a



MALLET ARTICULATED COMPOUND, B. & O.

total weight of 196,000 lbs. distributed over a total flexible wheel base of 23 ft. 0 3/4 ins., with a rigid wheel base of 6 ft. 10 in. The total weight is dis-

### About Car-Hogs.

The railroad car-hog is one of the disagreeable things developed by railroad progress. Although technically a biped, he seems to be more nearly allied to the genus quadruped. He has become a target for sharp squibs and unqualified censure, but no amount of ridi-

cule or denunciation has any effect in the way of softening his hard and selfish nature. He is apparently irreclaimable. No legal process can reach him. He can not be boycotted nor lynched, and his callous sensibilities are proof against all written or unwritten codes of civility.

There are a good many distinct varieties of the car-hog, although the term, as commonly used, is understood to mean a person who looks upon the car he happens to be riding in as his own individual property, and upon everybody else in it as intruders; and he therefore has no scruple about appropriating to himself as much seating room as he can spread himself over, and from which he can only be dislodged by strategy or assault. The other varieties of the hog are, as a rule, somewhat less aggravating, for the reason that their rudeness does not arise so much from ingrained selfishness as from lack of training in re-



TWO-SECTION ELECTRIC FREIGHT LOCOMOTIVE, B. & O.

We are indebted to Mr. J. E. Muhfeld, general superintendent of motive power of the Baltimore & Ohio for this information, and to the American Locomotive Company for the illustrations which we are able to present to our readers.

gard to the decencies and proprieties of life. They have less of the surly, unaccommodating spirit which distinguishes the car-hog proper, but the annoyance they cause is sometimes very exasperating.

There is a car whistler, who whistles

unconsciously from force of habit. He pitches his music in a low key and fancies he is whistling to himself while he is tormenting everybody within hearing. Then there is the baked peanut eater, the loud talker who has a liking for argumentative controversy, or who thinks that everybody around him is interested in the details of his business or his views of current political issues. But the most maddening of all tormentors is the man who reads aloud newspaper accounts of prize fights and murders, or whatever else his seat companion will listen to. These wretches are almost invariably lad readers, and make havoc with the pronunciation; casualty is "causalty," municipal is "mucipial," preventive is "preventative," and so on, all of which is perfectly ravishing to the ears of the college professor or clergyman in the adjoining seat. Then there is the window question, which is so familiar to all travelers, both the sinned against and sinning, that the mere mention of it is sufficient. Locking the seats back, so they can not be reversed at pleasure, is an excellent practice, and prevents many a well-dressed hog from reposing his hoofs on the cushion of the next seat. There is a habit very common with young men, as well as with men that are not so young, of bracing their knees against the back of the seat in front of them in order to get themselves into a reclining posture. This is grossly annoying to the occupants of such seat, especially if they are ladies. Offenders of this class should know that each seat and seatback is the exclusive property for the time being of its occupants, and that any encroachment upon it is unpardonable rudeness. The catalogue of offenses of this class might be very much extended, but those to which we have alluded will indicate the character of the rest.

Railroad companies and car builders have exhausted the resources of money and skill to make people who ride in their cars comfortable and happy, collectively. But mere mechanical devices in the way of luxurious seats, elastic springs, foot-rests, salubrious air, a well-regulated temperature and costly decorative surroundings, cannot insure civility and mutual courtesy among the passengers themselves. There is no mechanical device by which common sense can be pumped into the heads of boors and blatherskites as air can be pumped into a brake reservoir, or by which uncongential natures can be harmonized. The passenger car is the home for the time being of fifty or more people, who are brought together indiscriminately, and there is no place more favorable for the exhibition of good breeding, or the lack of it, on the part of the occupants. It is to be hoped that the car-hog of the period is not an abiding institution, and

that he will finally succumb to public censure and mend his ways.

#### Mountain Climber in Upper Burma.

When one hears of Burma, now part of Britain's empire in India, one naturally associates the name with that of the capital city and with Rudyard Kipling's "On the Road to Mandalay." The little mountain climber which we illustrate is, however, on another road, and is far to the north and west of Mandalay.

The engine is on the Darjiling-Himalayan railway, which is a prosperous little narrow gauge road, 24 ins. wide and about 50 miles long. It runs from Silligore, which is the terminus of the northern section of Eastern Bengal state railway, and goes up to Darjiling, one of the hill towns of India.

One of our many friends in that far

for this service were built by Messrs. Sharp, Stewart & Co., of Glasgow. They are termed mountain climbers. There are no cogs in the center of the track, the engine pulls by the ordinary contact of driving wheel and rails. The water tanks are variously placed on the engine, the saddle tank, one under boiler and one under the cylinders holding in all 400 imperial gallons. The engines are fitted with Walschaerts valve gear, and they do their work remarkably well.

In our illustration the man next the engine is Engineman Duncan, and to his left is Engineman and Mechanic P. J. Wright, who was formerly connected with this road. A few of the principal dimensions are as follows:

Weight of Engine in Working Order—14 tons;  
weight on driving wheels, 7 tons 10 cwt.;  
weight on leading wheels, 6 tons 10 cwt.  
Diameter of Wheels—2 ft. 2 ins.; diameter of cylinder, 11 ins.

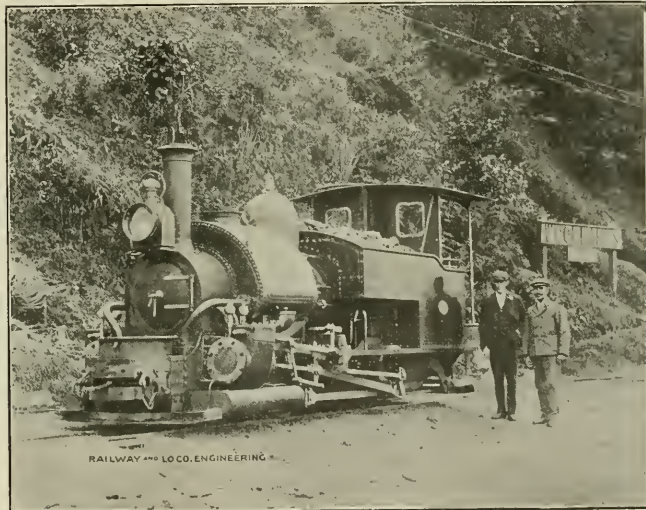

NARROW GAUGE MOUNTAIN CLIMBER IN THE HIMALAYAS.

away country, Mr. P. J. Wright, to whom we are indebted for the photograph and information, says that the principal upward traffic is rice—and downward tea—as well as a good deal of passenger travel. Darjiling is the terminus of the little railway, and is every year visited by tourists from all quarters of the globe to see the little railway and to enjoy a sight of the highest peak in the world, Mount Everest, 29,000 ft. above sea level, in the main range of the Himalayas. The journey by train from Silligore to Darjiling, which is 7,000 ft. high, is done in 6 hours, including 1 hour 25 minutes stoppage for water, fueling and refreshments along the line. The average gradient being 1 in 30. The sharpest curve being 75 ft. radius. The engines

Length of Stroke—14 ins.  
Heating Surface of Tubes—276 lineal ft; of fire box, 40 ft. 5 ins.  
Fire Grate—Length, 3 ft. 7/16 ins.; breadth, 11 ins.  
Total Grate Area—8.75 sq. ft.  
Number of Tubes—65.  
Size of Tubes—1½ ins.  
Capacity of Coal Bunker—15 cwt.  
Length of Engine Over Buffer—19 ft. 2½ ins.  
Height from Rail to Top of Chimney—8 ft. 5 ins.

By the end of the year the Bessemer and Lake Erie Railroad company expect to have in their tracks 105,700 steel ties, which will cover 42 miles of track and weigh 9,550 tons. Experimental lots are being laid by ten other companies, and the results of their operations are being watched with interest.

### Convention Exhibits.

The 39th annual convention of the Master Mechanics' and the 40th of the Master Car Builders' Associations were held this year at Atlantic City, N. J. The town is a seaside resort built upon a sand bar about a mile wide, and separated by salt marshes from the main land. The beach at Atlantic City is perfect for bathing and fronting the sea and just out of tide reach is about five miles of planked promenade called the "board-walk" along which are hotels, stores, booths, entertainment halls, restaurants, etc.

As is usual at these conventions, Reeves American Band-orchestra, of Providence, R. I. with the well-known conductor, Mr. Bowen R. Church, was on hand, and it is needless to say that the music furnished was excellent in every way. Many bands seem to be always anxious to rest and fill in their programs with magnificent silent spaces. Not so the Reeves band, each member is a picked musician and they are all in earnest and really work when they play, and Mr. Church is not only a good conductor but is an engineer as well in his own way. Probably the most popular airs this year were "Moonlight" and "Sorella;" the latter is a delightful Spanish march, called "Polo" in this country. It makes an excellent two-step in the ballroom. During the M. C. B. convention the band gave a sacred concert on Sunday. Those who had the pleasure of hearing it had the satisfaction of knowing that they had certainly gone to church.

The exhibits on the steel pier were most comprehensive, embracing as they did about every known railway appliance which could in any way appeal to the car builder or the engineer. The inventor and the demonstrator and the salesman were much in evidence, and these when mingled with the members of the two associations made a gathering so truly representative of our modern progress in applied science as almost to merit the description applied by the citizens of Thessalonica to Paul and his followers, "These that have turned the world upside down are come hither also."

Among the exhibits we may mention the following:

Acme Ball Bearing Company of Chappaqua, N. Y. Their exhibit consisted of Acme ball bearing jacks and a number of Acme ball bearing casters.

Adreon & Co. of St. Louis, Mo. They showed the Simplicity Bell ringer operated by air and as the knocker of their exhibition bell was tied, the bell swung noiselessly to and fro with an intermittent whiff of compressed air, the Adreon improved key bolt fastening for brake shoes, also the Adreon-Morse

ratchet wrench with drill socket and brace. They exhibited a photograph of an improved steel railroad water tank.

Armstrong Brothers Tool Company of Chicago. This was the exhibit of the well known "tool holder people," and all kinds of tool holders were shown for lathe, planer and slotter tools, also lathe dogs, tool posts of improved pattern, planer jacks, bolt drivers and short ratchet drills. The universal ratchet drill was on view; it gives a circular motion even when, in a tight place, the ratchet handle is capable only of a straight up and down motion. In fact all sorts of ingenious devices in standard sets involving the tool holding principle were to be seen in this interesting display.

American Balance Valve Company of Jersey Shore, Pa. The striking feature of this exhibit was a beautifully made and very substantial working model of the Walschaerts valve motion, with

tion to cylinders, with small cylinder clearance.

American Brake Company of St. Louis exhibited a driving brake and an automatic brake slack adjuster.

American Brake Shoe & Foundry Company of Mahwah, N. J., had a large display of reinforced brake shoes, steel back and wrought iron lug brake shoes, brake shoes of new design showing the improved method of construction of wearing surface and of attaching points. There were samples of worn shoes showing how the improved make enabled the user to run them down to almost pancake thickness, and not loose the shoe. Brake shoes for engines, flanged shoes for tenders and coaches, and ordinary unflanged shoes for freight cars. Locomotive driver brake shoes of various kinds were shown having the Christie principle of attachment. One might almost sum up the whole exhibit by saying that there were all sorts of brake shoes suitable for all the condi-



BEACH AT ATLANTIC CITY, N. J.

piston valve as used on the Pennsylvania Railroad. It was one-quarter size and many were the offers made for its purchase. There was also one of the Jack Wilson double acting slide valves such as are used on the Philadelphia & Reading Atlantic City flyers. There was to be seen a semi-plug piston valve, as it is, after two years and nine months actual service, and from this the wearing qualities of the valve could be judged at a glance. Two semi-plug piston valves were shown, one for external and one for internal admission, a reversible semi-plug piston valve, also a double-end one and a semi-plug piston valve for passing over ports without bridges. Among the Jack Wilson slide valves were a high pressure double action valve for internal admission, of the three ring type. The same valve adopted for external admission and a double acting valve for internal admission suitable for applica-

tions which arise in steam or electric railway service.

American Car & Foundry Company of New York exhibited a steel passenger coach on the yard tracks at the Pennsylvania railroad station in Atlantic City. The coach was one of the New York Central's new equipment for passenger service. It is 66 ft. over all and weighs 105,000 lbs. It is of course completely non-inflammable and will seat 64 persons. The wheels are steel, 42 ins. in diameter, and the car is intended for high speed service. There will be 180 of these cars built for the N. Y. C.

American File Sharpener Company of New York exhibited one of their machines called the "Carbofynt," from the nature of the substances used. The Fulton friction tapping machine was also on view and one of the Hercules folding steel ladders.

American Lock Nut Company of Boston, Mass., showed their device for



## Old-Timer Talks No. 5



The other day I took my micrometer calipers and measured some flakes of Dixon's Graphite.

They averaged about .0005 of an inch—pretty fine, eh?

Well, that's one of the reasons why Dixon's is the best graphite an engineer can use. Friction, of course, is only between the rubbing surfaces. These thin flakes cover the most surface and thus give the maximum results with a minimum quantity. These flakes take the wear, too.

But don't get the idea that Dixon's Graphite will build up and bind the moving parts; it never will. It is so soft that it can be easily worn down by rubbing with the fingers. Any tendency to build up would be overcome at once by the moving surfaces. I'd get sample No. 69-C if I were you.

Joseph Dixon Crucible Co.  
Jersey City, N. J.



preventing the slacking back of a nut on a bolt. It consists of a rocking key set in a radial slot opposite one of the angles in the nut, and this engages at right angles with a thread of the bolt. The key is securely fastened in the lock, but the fastening of the key in the slot does not prevent it being locked and unlocked.

American Locomotive Company of New York had on the exhibition tracks near the Pennsylvania station two locomotives. One was a B. & O. heavy 2-8-0 engine. This is the type which was tested and criticized by the motive power department of the road, before any others of the same class were built. It was fully illustrated and described in RAILWAY AND LOCOMOTIVE ENGINEERING JANUARY, 1906, issue, page 9. The engine at Atlantic City, however, had Walschaerts valve gear. The second engine was a simple 4-6-2, built for the Erie. The cylinders were 22½x26 ins., fitted with piston valves and Stephenson link motion, drivers 74 ins., tractive power 30,260 lbs. Weight on drivers 149,000 lbs., factor of adhesion of 4.93. The boiler is straight, 75 ins. in diameter at the smoke box end, fire box 75x108 ins., heating surface 3,322 sq. ft. Tubes 20 ft. long. The tank holds 8,500 gallons of water and carries 16 tons of coal. Both of the machines exhibited were good examples of the work done by this company.

American Steam Gauge and Valve Mfg. Company of Boston, Mass., showed some fine specimens of indicators of the improved American-Thompson type, with the new detent motion, which makes the action of the drum more easily controlled. Their dead weight gauges tester was also in evidence and locomotive muffled and open pop valves, and several hydraulic relief valves. The company also exhibited their locomotive steam gauges, steam heat and American duplex gauges.

American Steel Foundries of Chicago. The simplex bolster and brake beam for tenders and freight cars. Cast steel bolsters for cars. Locomotive driving wheel centers, crossheads and side rods. Elliptical springs for locomotives and for passenger car trucks. A model of the Janney coupler. Davis balanced driving wheels, coil springs with controllers for various capacities of freight cars. A complete car truck equipped with Simplex bolster and brake beams. Susemihl roller, side bearings and the Andrews steel side frames, which permit of easy and quick removal of the axle boxes.

American Water Softener Company of Philadelphia had as an exhibit a most complete working model of their water softening plant, together with photographs of the water softening in-

stallations, which they have applied on various railways in this country.

Badeker Metallic Packing Company of Omaha, Neb., had a number of samples of their automatic metallic packing for use on piston rods and valve stems.

Baeder, Adamson & Company of Philadelphia, exhibited a neat little model of a railway refrigerator car showing their method of hair felt insulation and system of refrigeration.

Baker Heating and Supply Company of New York had on view their well-known double coil Baker car heater, made with riveted steel shell and steam attachment, also their No. 9 double coil fireproof heater, the double coil perfect heater No. 8, the mighty midget No. 4 Baker heater, one of their No. 6 street car heaters and independent steam attachments.

Baldwin Locomotive Works of Philadelphia had on the exhibition tracks at the Pennsylvania station, two locomotives, one a 4 cylinder compound 4-4-2, built for the Union Pacific. This engine conforms as much as possible to the details used on the Associated Lines. The engine has cylinders 16 and 27x28 ins., 81 in. driving wheels, a total estimated weight of 209,000 lbs., of which about 110,000 lbs. rest on the drivers. Piston valves are used and Walschaerts valve motion actuates them. The rear driving axle is cranked and the main rods from the inside crossheads are built up and are made with a loop, which spans the first driving axle. The other simple engine is a 4-6-2, built for the Great Northern. Cylinders 22x30 ins., 69 in. drivers carrying 151,000 lbs. The estimated total weight is 227,000 lbs. Richardson balanced valves and Walschaerts valve gear. Both engines are excellent examples of the modern locomotive builders' art.

Baldwin Steel Company of New York. This exhibit consisted of a complete line of the Hudson high speed steel tools for use in a railway repair shop, and included Hudson tire turning tools, locomotive taper reamers, bridge reamers, track drills, twist and oil tube drills and staybolt reinforced taps.

Barnett Equipment Company of Newark, N. J. There was shown a Barnett connector, which automatically couples the steam heat, air brake and signal lines. It can be applied so as to couple any size or make of steam heat connection. Automatic safety hooks used in place of safety chains, and all metal pipe connections between cars for use instead of rubber hose.

Baltimore Railway Specialty Company of Baltimore, Md. There was shown in regular operation a special tool for grinding side bearing race plates where steel balls are used; also the very ingenious time saving and accurate

method of centering the race plates in center bearings, for steel balls and numerous samples of side and center bearings both new, and those which had been for many months in service. Samples of steel balls and race plates.

Belle City Malleable Iron Company of Racine, Wis. This company exhibited their adjustable "L. & S." anti-rail creeper and explained its construction and operation.

Bettendorf Axle Company of Davenport, Ia. This was a large exhibit and included a complete Bettendorf tender truck just as it would be used in actual service. There was also a 40-ton freight truck of the Bettendorf type, designed to take Barber rollers, and a 30-ton freight truck complete. They also showed a pair of 50-ton freight trucks with body bolsters and pieces of center sills riveted up. Two I-beam Bettendorf bolsters, and center sills arranged for Miner draw gear, and one cast steel truck frame with removable axle boxes. The trucks, etc., exhibited were what are used in railway service and were shown exactly as they came from the factory. The exhibit was life size in every respect.

Bethlehem Steel Company of South Bethlehem, Pa., had an exhibit in one of the rooms of the Marlborough Hotel and it consisted largely of small steel products and photographs of larger work.

Bliss Electric Car Lighting Company, Milwaukee, Wis. This display was made up of an electric generator, for use on a locomotive tender, also a car generator. Bliss bucket switch boxes, junction boxes, vestibule type of train line coupler, coupler for steam line on trains, also an electric generator brush rigging and pole changer, field coils and armature used in the lighting equipment.

Bordo Company, the L. J., of Philadelphia. The Bordo blow off valves for locomotive and stationary boilers were on view, in service condition and taken apart, also their gauge cocks for locomotive and stationary boilers, also their water connection for use between engine and tender. This consists of a swinging pipe connection in the form of the letter V, with moveable joints at the angle and the two upper extremities. The connection was equipped with a water strainer placed in the lowest joint and easily get-at-able by the removal of a cap screwed on at one side. This flexible or swinging connection can be used with water, steam, air or oil.

Bowser & Company, Inc., the S. F., of Ft. Wayne, Ind. This company exhibited railway oil house equipment, consisting of storage tanks for lubricating and paint oils. Self-measuring power pumps and self-measuring tanks, and various other tanks and receptacles

for the storage of all kinds of railway oils.

Buffalo Brake Beam Company of New York. This exhibit was composed of Vanderbilt and Buffalo brake beams, made of structural steel with forged steel or malleable iron fulcrums and chain clips. The fulcrums are ingeniously constructed and easily applied. They may be either right or left, as occasion requires.

Bullard Automatic Wrench Company of Providence, R. I. Bullard wrenches, made in various sizes were on view. This wrench may be used for ordinary nuts or will grip a pipe like the grasp of a man's hand.

Butler Drawbar Attachment Company of Cleveland, O. The various Butler specialties were shown, consisting of Butler friction drawbar attachments, tandem spring attachments with 8x8 in. and 6 1/4 x 8 in. draw springs. Butler tandem spring attachments suitable for Harvey friction springs, and Piper patents 250,000 lbs. capacity.

Burgess, B., of Danville, Ill., showed the Burgess rail anchor, for use in wrecking operations, also the Schott incline jack.

Camel Company of Chicago had a number of security car door fixtures, also the improved Durham-Hartman ball bearing center plate and side bearings for cars and the Chafee hose clamp.

Carborundum Company of Niagara Falls, N. Y. Carborundum is an artificial abrasive and is practically composed of carbon and sand. It is the nearest approach to the diamond ever made by man. The exhibit consisted of samples of carborundum and its products for use in grinding and polishing operations.

Carey Mfg. Company, Philip, of Cincinnati, Ohio. Magnesia and asbestos pipe and boiler covering was shown, also magnesia flexible cement roofing, asphalt paints for use on roofs and smoke jacks. Their standard freight car roofing, asbestos paper and mill board, asbestos rope and wick packing, asbestos gaskets, and fire proofing material.

Chicago Car Heating Company of Chicago, Ill. Their vapor system of car heating equipment was shown, also a combination of the vapor and pressure system, and the standard pressure system of heating. Frost proof steam traps, hot water car heating specialties and a recently designed hose coupling for use with their car heating systems.

Chicago Pneumatic Tool Company of Chicago. This extensive exhibit comprised what is known to the trade as a full line of pneumatic hammers, drills and riveters, the Little Giant, the Boyer and the Keller drills, holding on tools, air operated sand sifters, rammers for use in the foundry. These are the tools that know enough to pound sand, and

## The Best and Cheapest Books for Railroad Men

**AIR BRAKE CATECHISM** Price, \$2.00

By Robert H. Blackall. 20th Edition. Contains 1500 Questions and their Answers on the Westinghouse Air Brake, which are strictly up-to-date. Includes two large Westinghouse Air Brake Educational Charts printed in colors. Gives the necessary information to enable a railroad man to pass a thoroughly satisfactory examination on the subject of Air Brakes. The author's many years' experience as Air Brake Inspector and Instructor enables him to know at once how to treat the subject in a plain, practical manner. Endorsed and used by Air Brake Instructors and Examiners on nearly every railroad in the United States. The standard and only complete work on the subject. 312 pages.

**LOCOMOTIVE BREAKDOWNS AND THEIR REMEDIES** Price, \$1.50

By Geo. L. Fowler. Just issued. Tells how and what to do in case of an accident or breakdown on the road; includes special chapters on Compound Locomotives. Better preserve a copy, as it contains 800 Questions and their Answers on Accidents and Breakdowns.

**LOCOMOTIVE CATECHISM** Price, \$2.00

By Robert Grimshaw. 22d Edition. Is right up-to-date and contains twelve large Folding Plates and 1600 Questions and Answers on How to Run a Locomotive. The Standard Book on the subject, being written in plain language and free from mathematical formulæ and complex problems.

**NEW YORK AIR BRAKE CATECHISM** Price, \$1.00

By Robert H. Blackall. The only complete treatise on the New York Air Brake and Air Signaling Apparatus giving a detailed description of all the parts, their operation, troubles, and the methods of locating and remedying the same. 250 pages.

**COMBUSTION OF COAL AND THE PREVENTION OF SMOKE** Price, \$1.50

By Wm. M. Barr. Contains over 800 Questions and their Answers on the Science of Steam Making.

**AIR BRAKE CHARTS** Price, 50c.

Showing the Westinghouse Equipment in ten colors, including freight and passenger engine. Every railroad man should possess these charts at this low price.

**A Special Circular** of any of these books sent on request. Any of these books sent prepaid on receipt of price.

**Agents Wanted at Every Terminal.** Write for our special terms. You can make equal to a month's pay selling our books on the side

**The Norman W. Henley Pub. Co.**  
132 Nassau Street, New York, U. S. A.

# "J. M."



## RAILROAD SUPPLIES

### OUR NEW CATALOG

of "J.-M." Asbestos and Magnesia Railroad Supplies is now ready for distribution. This is the most complete catalog of its kind devoted entirely to Railroad Materials.

WRITE FOR CATALOG  
NO. 250-A TO-DAY

### A Few J.-M. Products

Smoke Jacks  
 "Transite" Fireproof Lumber  
 Asbestos and Magnesia Locomotive Lagging  
 "Vulcabeston" Pump Packing  
 "Vulcabeston" Gaskets  
 "Vulcabeston" Rope Packing  
 Train Pipe Covering  
 "Kearsarge" Gaskets  
 All grades of Asbestos and Magnesia Pipe Covering  
 Hair Felt  
 "Keystone" Hair Insulator  
 Asbestos Cements  
 "Retort" Cements  
 "Canadax" Wick Packings  
 High Pressure Asbestos Packing  
 Asbestos Roofing  
 Portland Sectional Conduit

### H.W. JOHNS-MANVILLE CO.

Manufacturers of Asbestos and Magnesia Products, Asbestos Roofings, Packings, Electrical Insulating Materials, "Noark" Fuse Devices, Electric Railway Supplies, etc.

NEW YORK	ST. LOUIS	MINNEAPOLIS
MILWAUKEE	PITTSBURG	DALLAS
CHICAGO	CLEVELAND	SAN FRANCISCO
BOSTON	NEW ORLEANS	LOS ANGELES
PHILADELPHIA	KANSAS CITY	SEATTLE
	LONDON	

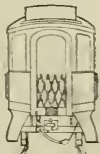

215

the air driven variety which were on exhibition do good work quickly and plenty of it. There were storage batteries, air cooled electric drills for all sizes of holes from  $\frac{1}{8}$  in. up to  $3\frac{1}{2}$  ins. Electric grinding and buffing tools, stay-bolt nipper, yoke riveters, a pipe bending machine and several speed recorders. There was also one of the company's latest type of Franklin Air Compressors, surnamed the noiseless, and the absence of any click-clacking racket is secured by the use of mechanically operated inlet valves and a patent outlet poppet valve, and the magnetic "old man" with a 1,500 lbs. pull. All the atmosphere has to do with this machine is to go into it and be compressed without noise or fuss.

Chicago Railway Equipment Company of Chicago. Brake beams were here a prominent feature and those exhibited were the Creco, the National Hollow, the Diamond and the Kewanee. Among their other specialties were the Monitor truck and body bolsters, Creco roller side bearings and the Creco journal box and lid. Pneumatic hose, Bowes' couplings, and hose clamp tools.

Clark Automatic Nut Lock Company of New York. The nut lock exhibited consists of a specially made washer; the bolt and nut are the ordinary kind and are not modified in any way. The washer is stamped out of steel plate and is no thicker than ordinary washers. On the circular edge of the washer which surrounds the bolt there is a little sharp point like the end of a toothpick raised up in the stamping, and being raised or slightly bent back from the face of the washer it does not touch the threads of the bolt when the washer is slipped on, so the washer slides easily along the bolt. When the nut is tightened up it presses this spring toothpick point, as we have called it, into the bolt and heds it there, making a slight indentation in the side of the bolt. This prevents the washer from turning. On the upper side of the washer on the outer edge, there are three cuts, which permit of three sprung up points, which are formed in the stamping of the washer, and these make, as it were, three pawls which the nut in turning on cause to spring slightly when the nut angles pass. The nut can go on all right, but it can't back off against the spring points of the washer, for one of them is always holding against a nut angle and the toothpick point keeps the washer stationary, so the nut has to stay where it is put for all time. When the nut has to be turned off the forcible action of the wrench breaks off the spring point holding the nut and the pressure being relieved on the toothpick point the nut and washer comes off easily and quickly.

Cleveland Car Specialty Company of Cleveland, Ohio. This company made their exhibit booth with the material they sell. It was formed of pressed steel carlines for freight cars, and there were several kinds of these, and they also exhibited a pressed steel spring plank for freight equipment.

Cleveland Pneumatic Tool Company of Cleveland, Ohio. This company showed a number of chipping, riveting, and caulking hammers and beading tools, also some drills, both reversible and non-reversible, five sizes in all; stay-bolt riveters, stone and scaling hammers, wood boring machines, drift bolt tools and hammers and drills for submarine work.

Cling Surface Company of Buffalo. The best example of non-political "pull" on the ground. The exhibit showed a tight belt doing work on a pair of pulleys and along side a very slack belt treated with cling surface paste doing better work on another pair of pulleys and without any slip. The exhibit told the whole story. When cling surface was used the tension of the belt is like the flowers that bloom in the spring—it has nothing to do with the case.

Commercial Acetylene Company of New York. This company had a booth, which at night had gas to burn and brilliance to give away. They showed their acetylene safety storage tanks, one of them cut in section, revealing the asbestos filling, and they explained the storage system which renders explosions impossible. They had car fixtures and brackets, portable table lamps, an acetylene locomotive headlight and a yacht searchlight, both of which shed light over the pier and the suri rolling in from the sea. On the exhibition tracks at the Pennsylvania station there was a N. Y. N. H. & H. passenger coach lighted with acetylene, taken out of regular service and brought to Atlantic City without any special preparation. A detailed account of the process of producing and using acetylene in railway service and of the safety storage system was given in the June issue of RAILWAY AND LOCOMOTIVE ENGINEERING, on page 278. It is headed " $\text{CaC}_2 + \text{H}_2\text{O} = \text{C}_2\text{H}_2 + \text{CaO}$ ." Read it and so get light, then use the light.

Consolidated Car Heating Company of New York. Hot water and direct steam heating systems for railway cars were shown, steam valves, train pipe end valves, thermostatic traps, hot water drums, pipe fittings, steam pipe couplers with automatic locking device, and the McElroy automatic car lighting system was shown in operation.

Consolidated Railway Electric Lighting & Equipment Company of New York showed the well known "Axle Light" system, as it is commonly called.

The "D" type generator mounted on a passenger car truck and so arranged that the movement of the truck frame which carries the generator is allowed for and the constant steady spin of the armature is never interfered with. The Kennedy combination current and voltage regulator was also shown. This is a most ingenious piece of mechanism. The sum total of the whole thing is that when a car is running the revolving of the axle as the car runs along, generates an electric current, which acts upon the elements of a storage battery when the light is not being used, and where the light is used any surplus current still goes to the battery. When the car stops the storage battery gets in its work and keeps the lights going, or the fans for cooling the air in the car, for that matter. It is the function of the Kennedy regulator to see to the correct distribution of the current, and the quiet but efficient way it attends to business is an object lesson to us all.

Crandall Packing Company of Palmyra, N. Y. This company exhibited samples of air pump throttle packing. They make packing which is lubricated

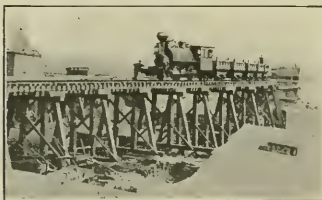

MAKING A FILL AT ROCKLAND, ME.

by their cold oil process and is suitable for steam, ammonia, air, gas, acid and hydraulic pressure. A very useful little book, called the Success Atlas and Gazetteer may be had by applying to their New York office, 136 Liberty street. It is of convenient size and contains more than 500 pages. It has 105 maps, 40,000 index entries and the latest areas and census statistics. You will not readily get lost if you have one of these little books.

Crosby Steam Gauge and Valve Company of Boston, exhibited locomotive steam gauges, open and muffler pop valves, blow-off valves, globe and angle valves, air brake recorders and locomotive chime whistles.

Davis, John, of Chicago, showed armored hose for railroad use, also the Gunnell hose couplings and reducing valves for train heating service.

Davis Pressed Steel Company of Wilmington, Del. A special brake beam testing machine, having a capacity of 150,000 lbs. in operation, was one of the features of this exhibit. The company also showed brake beams for large capacity freight cars and high speed brake

service on passenger equipment. The brake beams are ingeniously made with the truss rod part of the original rolled section, cut off and bent back, but having at the ends the original connection, so that no weld or clamp or bolt is required to unite the beam and the supporting truss rod.

Dearborn Drug and Chemical Works of Chicago. The display consisted of water purifying chemicals. They also showed some interesting examples of boiler tubes pitted and corroded by the action of water impregnated with the salts of soda and others showing the effects of incrustations caused by water containing sulphates.

Detroit Lubricator Company of Detroit, Mich. This interesting exhibit showed the original bull's eye type of lubricator in four styles, from two feed up to five, and the company is contemplating increasing the capacity to seven. The well known No. 21 triple-feed lubricator was shown in sections and the interior construction and method of holding the glass was thus displayed. The No. 41 five-feed, which has been extensively used on engines using superheated steam was also shown and the new and superior quality of glass which supersedes the kind formerly made was also on view.

Detroit Seamless Steel Tube Company of Detroit, Mich. This was a very tastefully arranged exhibit and in it could be seen specimens of the Detroit cold-drawn seamless open hearth steel locomotive tubes in all stages of manufacture, from the first process up to the finished product. Safe ends as made by this company were also on exhibition.

Dickinson, Paul, of Chicago, displayed round house smoke jacks made of cast iron and Vitribestos, Universal ventilators and Universal chimneys were also shown.

Dixon Crucible Company, Joseph, of Jersey City, N. J. This well known concern had an admirable display of the Dixon graphite products for railroad use, such as the Ticonderoga flake graphite lubricants, graphite greases, the Dixon pipe joint compound which when applied to pipe joints and fittings permits them, when wanted to be, quickly and easily taken apart. Plumbago crucibles were also shown, silica graphite paint for iron and steel, and last but not least lead pencils of all descriptions and varieties, which, by the way, are always made of the purest graphite.

Dressel Railway Lamp Works of New York had a good assortment of locomotive headlights and headlight burners, engine lamps, tail lights, switch, semaphore and caboose lamps. The lamps were elegant in design and well-finished and of good quality.

Duff Mfg. Company of Pittsburgh, Pa., showed the various forms of

# GOLD Car Heating and Lighting Co.

Manufacturers of

**ELECTRIC,  
STEAM AND  
HOT WATER  
APPARATUS  
FOR RAILWAY CARS**

**EDISON  
STORAGE  
BATTERY  
FOR RAILWAY CAR  
LIGHTING**

Largest Manufacturers in the World  
of Car Heating Apparatus

Catalogues and Circulars  
cheerfully furnished

Main Office, Whitehall Bldg.  
17 BATTERY PLACE  
NEW YORK

# Homestead Valves

Straightway, Three-way and Four-way,  
and

# Homestead Locking Cocks

Are Famous the World Over

They cost more, but are worth very much more than other makes. You try them and see.

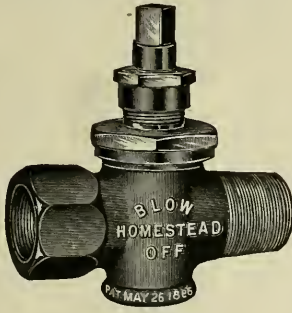

Brass, 1 1/4 in., \$6.00 net

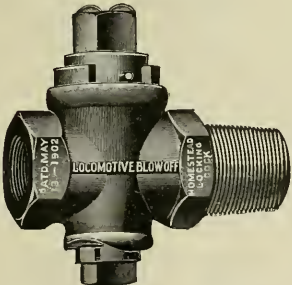

Iron Body, Brass Plug, 1 1/4 in., \$4.00 net

## Homestead Valve Mfg. Co.

WORKS,  
HOMESTEAD, PA.      PITTSBURG, PA.

## American Locomotive Sander Company

13th & Willow Sts., Philadelphia, Pa.

Proprietors and Manufacturers

LEACH, SHERBURNE, DEAN,  
HOUSTON, "She" and CURTIS      SANDERS

### THE ROBERT W. HUNT & CO.

Bureau of Inspection, Tests and Consultation,  
1137 THE ROOKERY, CHICAGO.

66 Broadway, New York.      Park Building, Pittsburgh.  
31 Norfolk House, London, Eng.

Inspection of Steel Rails, Splice Bars, Railroad Cars,  
Wheels, Axles, etc. CHEMICAL LABORATORY—Analysis  
of Ores, Iron, Steel, Oils, Water, etc. PHYSICAL LABO-  
RATORY—Test of Metals, Drop and Pulling Test of Com-  
pensators, Draw Bars, etc.  
Efficiency Tests of Boilers, Engines and Locomotives.

the Barrett jack, such as track jacks, car jacks, geared ratchet lever jacks, Duff roller bearing screw jacks and cone bearing screw jacks.

Falls Hollow Staybolt Company of Cuyahoga Falls, Ohio, had a constant stream of visitors who were interested in the solid and hollow staybolt iron bars exhibited. There were also a number of test samples of this iron which, bent and broken in various ways, were intended to show the quality of the material. The representatives of the company stated that while at Atlantic City they had received through their Berlin Agency a fourth order for a carload of double refined charcoal iron, for the Imperial Railways of Germany.

Flannery Bolt Company of Pittsburgh, Pa. This company are the makers of the Tate flexible staybolt and they exhibited the various parts separately and had sample fire box sheets showing the application of the flexible stay, together with a complete set of tools for putting in the bolts. There were also exhibited a number of illustrations, showing the practice on various roads using the bolts and the extent and position of the fire box areas to which the Tate flexible staybolt had been applied.

Foster Company, Walter H., of New York, showed two very interesting machines for locomotive work. They were the Lassiter staybolt threading and reducing machines, which is a high capacity tool, and the Lassiter straight and taper bolt turning machine; also special grinders and chasers were shown.

Franklin Mfg. Company of Franklin, Pa. This concern showed their large variety of K. & M. magnesia and asbestos products.

Franklin Railway Supply Company of Franklin, Pa., exhibited a number of interesting railroad specialties among them were their pneumatic fire door opener, as applied to three styles of locomotive firebox doors, their steam chest plug, their piston head and cross-head connection. The McLaughlin flexible metal conduits, and the McLaughlin lock nut.

Frazer Specialty Company of Detroit, Michigan, had an exhibit of their locomotive front end paint, non-corrosive pipe joint paste, locomotive joint and boiler front cement.

Frost Railway Supply Company of Detroit, Mich. This exhibit consisted of the Harvey friction draft gear and Harvey friction springs. The display was comprehensive and the various parts were displayed separately as well as in the assembled form ready for use.

Galena Signal Oil Company of Franklin, Pa., had their headquarters in one side of the circular pavilion on the steel pier, and representatives of the com-

pany received the many callers who dropped in. There was no exhibit in the ordinary sense of the word, but among the things of interest in their handsomely furnished reception room was a large oil painting by the celebrated French artist Lubin, which was called the "End of the Strike." The story told by the picture is that a young and wordy agitator, probably lacking skill as an artisan, had been haranguing a number of workmen at the noon hour recess, and endeavoring to induce them to strike, so that they may avenge some fancied wrong. He is at last confronted by an old blacksmith, who has labored in the sweat of his brow and with the strength and skill of his arms for many years, and is beholden to none for his daily bread. The picture shows the crowd of workmen in the background; the agitator backed up against the wall in an



VIEW FROM THE STEEL PIER.

attitude of fear, while before him stands the man of work and will, his heavy sledge swung threateningly forward as he utters his ultimatum to the disturber, "Take the hammer or go."

General Electric Company of Schenectady, N. Y. This exhibit was on the tracks of the Pennsylvania Railroad, close to the passenger station. There was shown one of the N. Y. C. electric locomotives, built jointly by the General Electric and the American Locomotive Company. There were also two trucks built by the Am. Loco. Co., electrically equipped by the General Electric. The all steel car built by the American Car & Foundry Co., built for the N. Y. C., is mounted on trucks equipped electrically by the General Electric Company.

Garlock Packing Company of Palmyra, N. Y. This exhibit consisted of samples of packing for steam, water and ammonia pressures, also samples of the "Pit" metallic packing.

Gold Car Heating and Lighting Company of New York. This exhibit was arranged with steam hose connections for a full train of cars and exemplified their system of direct steam heat, as well as their hot water circulating system, improved steam couplers, automatic steam traps, temperature regulators, valves for end of train pipes, locomotive reducing valves, electric heaters, and their refrigerator car apparatus. The exhibit occupied considerable space and was most complete.

Goldschmidt-Thermit Company of New York, showed samples of their

Gould Storage Battery Company of New York showed storage batteries and battery cells and grids for train lighting and for railway signal service, both stationary and portable styles.

Green, Tweed & Company of New York. This exhibit was made up of samples of Palmetto air pump packing, "Exacto" packing gauges and cutters and Favorite reversible ratchet wrenches. The company gave as souvenirs a metal beetle which could be made to chirp for Palmetto when pressed between finger and thumb. The little beetle if laid on its back could

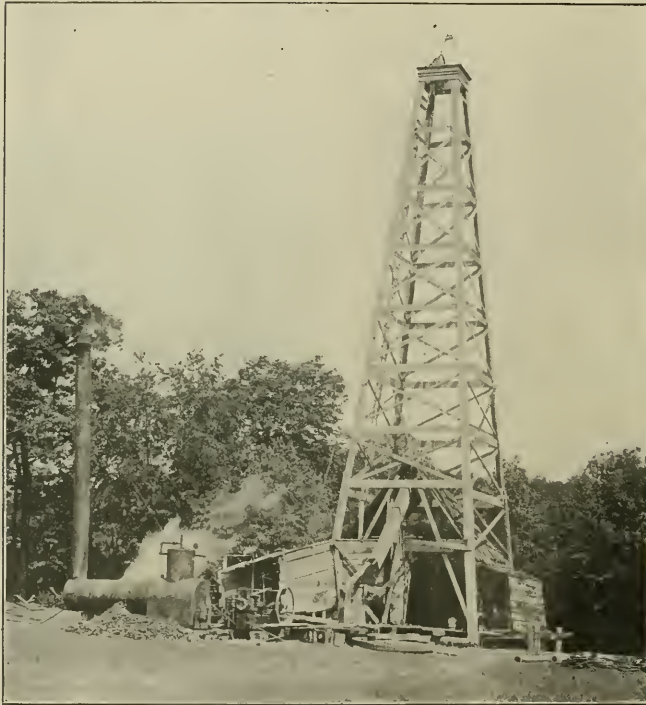

DRILLING AN OIL WELL, FOR RAILROAD USE.

process of welding samples of patterns and flasks for making molds for welding rails, sample metals and crucibles and samples of Thermit.

Gould Coupler Company of New York had on exhibition steel coupler and friction gear with cast steel bolsters, attachments for coupler, steel platform made with Z-bars equipped with friction buffer and draw gear having a coupler centering device, friction buffer for baggage cars. Model of vestibule, with platform, etc., journal boxes showing different methods of application, pivot coupler for tenders, coupler for front of engines and several freight car couplers.

be used by anyone so disposed, to learn telegraphing, as the sound emitted was exactly that of a Morse sounder. There was also an excellent brand of cigars for those who stopped to examine into the heat resisting qualities of the Palmetto packing. The cigars were not heat resisting however, but burned steadily and evenly and afforded almost as much satisfaction to the user as the packing does.

Hammett, H. G., of Troy, N. Y. This exhibit showed the Sansom bell ringer and balanced slide valves for locomotives. Mr. Hammett also showed the Trojan packing for locomotive piston rods. This is a metallic packing which

## Locomotive Blow-Off Plug Valves

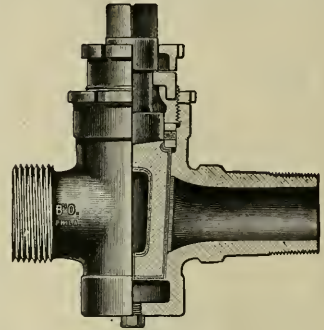

Fig. 9.

All Brass, extra heavy, with Cased Plug. For 250 lbs. pressure. Made with Draining Plug to prevent freezing.

## Locomotive Gauge Cocks

For High Pressure

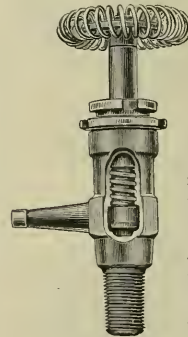

Fig 23, with Wheel.

Bordo Self-Grinding Gauge Cocks, made with renewable Hard Bronze Disc. Opened and closed with a quarter turn. Guaranteed Steam tight under the most exacting conditions. Shanks Threaded to specifications for Locomotives.

## Swing-Joints and Pipe Attachment

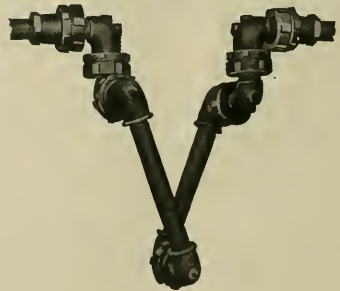

Fig. 33.

May be applied between Locomotive and Tender. These Swing-Joints are suitable for Steam, Gas, Air, Water or Oil.

Complete Booklet on Application

**L. J. BORDO CO.**  
PHILADELPHIA, PA.

# Ball's Official R. R. Standard Watches

16 AND 18 SIZE.



17 and 21 Ruby Jewels, Sapphire Pallets

Ball's Improved Safety Double Roller

Are without question the finest watches that American talent and skilled labor can produce, and they are giving such universal satisfaction that we have no hesitancy in claiming that they are the best and safest railroad watch on the market.

Tests ever and numerous have proven this fact to the most critical users in all sections of the country, to which thousands of good Railroad and Brotherhood men are ready to certify.

We have an authorized agent in nearly every railroad center. Call on him for information and facts. Write us for descriptive matter.

**The Webb C. Ball Watch Co.**

Watch Manufacturers

Ball Building, Cleveland, Ohio, U. S. A.

# THE UNION SWITCH & SIGNAL CO.

Consulting and Manufacturing  
Signal Engineers

Automatic Block Signals—Electric and Electro-Pneumatic

Interlocking—Electric, Electro-Pneumatic and Mechanical

Electric Train Staff Apparatus

GENERAL OFFICES AND WORKS AT  
SWISSVALE, PA.

DISTRICT OFFICES:

New York: 143 Liberty Street  
Chicago: Monadnock Block  
St. Louis: Frisco Building

is placed between two ball joint rings and is held together by a spiral spring. The packing, which is sectional in form, is held against the rod by the steam pressure which enters the space between the ball joint rings through very small holes. The packing therefore "floats" on the rod, if one may so say, and consequently adjusts itself readily to any irregular motion of the rod.

Hanlon Pneumatic Locomotive Sander Company of Winchester, Mass., had an exhibit of their locomotive sander showing method of getting at the sand valves, which are inside the box by unscrewing a cap from the outside. The valves, pipes, air jets, etc., were shown separately as well as in operation. The ability to easily clean the apparatus without emptying the box of sand is one of its many good points.

Harrison Dust Guard Company of Toledo, Ohio. There were four sizes of

Valves. The valves were shown in sections and in parts, also stationary boiler Blow-Off Valves, Three-Way, Four-Way and Straight-Way Valves, and the Homestead Locking Cock.

Independent Pneumatic Tool Company of Chicago, Ill. This exhibit consisted of a full assortment of the "Thor" Pneumatic Tools such as piston air drills and reamers; reversible, flue-rolling machines, tapping machines and wood saws, also the one-piece long-stroke riveting hammers, also chipping, caulking and beading hammers, pneumatic wood saws and grinding machines.

Ingersoll-Rand Company of New York. This company showed a number of pneumatic tools in which were chipping and riveting hammers, rotary and piston drills, wood boring machines, sand rammers for use in the foundry, pneumatic fan for ventilating purposes, air forges, motor hoists, pneumatic sta-



ENGINE ON THE GREAT INDIAN PENINSULA RAILWAY, DECORATED FOR THE PRINCE OF WALES' TOUR.

this company's dust guard suitable for the oil boxes of cars from 40,000 to 80,000 lbs. capacity, also the Harrison vestibule journal box, and their car journal lubricator as well as their cellar lubricator for driving boxes and their improved cellar.

Heath & Milligan Mfg. Company of Chicago, Ill. In this exhibit were several painted panels showing the "Ferrico" paint applied to wood and to iron, also painted panels showing colors for switch targets, etc., also a glass sign showing coach and car, colors, and some painted panel, exhibiting a comparative test of Heath & Milligan White Lead.

Homestead Valve Mfg. Company of Pittsburgh, Pa. This exhibit was conspicuous with an enormous model of the Homestead Locomotive Blow-Off

stationary motor and Ingersoll-Rand Air Compressors and Receivers.

International Correspondence School of Scranton, Pa. This exhibit was on the Pennsylvania exhibition track and consisted of the car "Scranton." In this coach was an exhibit of the company's method of teaching by correspondence, also a model of a locomotive and one of valve gear. The car contains a lecture room and sleeping accommodation of the crew.

Illinois Malleable Iron Company of Chicago. In this exhibit was an automatic swinging smoke jack; "imico" brass and malleable iron non-corrosive unions, also malleable pipe fittings.

Jenkins Brothers of New York. This well-known firm exhibited a large number of valves both of regular and extra

heavy make, also valves with brass and iron body, horizontal, angle, vertical and swing check valves, radiator valves, Y blow-off valves, excelsior back pressure valves, the Jenkins "1906" packing, also gaskets, gasket tubing, pump valves, disks, etc., and Sellers' restarting injectors.

Johns-Manville Company of New York. This exhibit consisted of asbestos products, and a full sized transite asbestos smoke jack ready for installation in a roundhouse, was on view. There were also samples of transite asbestos fire proof lumber. Portland sectional conduit, asbestos textile material, asbestos fibers and cements, Keystone hair insulator; samples of roll fire felt, asbestos mill board, and asbestos pipe coverings; also Vulcabeston Union washers, vulcabeston throttle rod packing, 85 per cent. magnesia and fire felt, sectional boiler lagging, asbestos cement felting, Kearsarge flange joint gaskets, standard piston rod packing, Canadax asbestos wick packing, asbestos mill board gaskets, asbestos roofing, Keystone combination pump packing, and Vulcabeston pump packing.

Kennicott Water Softener Company of Chicago. This company had a very tasteful exhibit, in which were pictures showing sections of their apparatus and photographs of the latest installations of their water softening plants on the various railroads of this country. The company reported extensions of their business in all directions. Indications are that the whole subject of water treatment for use in locomotive boilers is of growing interest in the railway world.

Landis Machine Company of Waynesboro, Pa. This company showed one of their 2-in. double head bolt cutters for use on regular bolt work and for stay-bolt cutting. In this latter operation the thread is cut without the use of a lead screw. Samples of work done by the machine were also exhibited.

Locomotive Stoker Company of Chicago, Ill. The exhibit of this company consisted of a Strouse Locomotive Stoker in actual operation. The mechanism can be adapted to any ordinary style of fire box and the stoker performs the work of coal distribution regularly and uniformly.

McConway & Torley Company of Pittsburgh, Pa. This company showed a set of their various couplers. These included the Janney freight coupler, the Kelso freight coupler, the Pitt freight coupler, the Kelso tender coupler, the Kelso pilot coupler, and the Janney passenger coupler. There was also an exhibit of the Buhop three-stem passenger coupler equipment applied to a standard steel platform. This exhibit

showed everything as it actually is in service and the couplers were mounted on a stand about the regulation height of couplers from the ground, which greatly facilitated their examinations.

McCord & Company of Chicago. The malleable iron axle box made by this company was of course in evidence in this exhibit, also the McKim gaskets, and McCord force feed lubricators. There were shown neat little models illustrating the new McCord friction draft gear, which depends for its absorbing power upon the lever-like action of two pivoted cams. This draw gear was described and illustrated in the June issue of RAILWAY AND LOCOMOTIVE ENGINEERING, page 293.

Manning, Maxwell & Moore, Inc., of New York. This well known firm displayed a large variety of products; among them was the Hancock inspirators, steam valves, check valves, stop valves, blow-off valves, Ashcroft steam gauges, air gauges, Edison recording steam gauges, indicators, metropolitan injectors, safety valves showing several sections. The Gridley automatic twist drill grinder.

Mason Regulator Company of Boston, Mass. This company exhibited their boiler feed pump, gravity pump governor, water reducing valves, Mason reducing valves for car heating, reducing valves for marine and stationary service, air brake pump regulators, balanced and lever valves, etc.

Merritt & Company of Philadelphia, Pa. This company exhibited their Metal Locker for railroad machine shops.

Metal Plated Car & Lumber Company of New York. This company exhibited the Brown Metallic Window Strips for railroad car service.

Michigan Lubricator Company of Detroit, Mich. This company exhibited a very full assortment of locomotive lubricators of the double, treble, quadruple and five-feed, Bull's Eye type 1906 design. These lubricators are arranged with a sight feed glass above the oil reservoir; also new type with eight feed glasses around the reservoir. Lubricators with oblong and round observation glasses, automatic shut off drain stem for lubricators, sight feed lubricators for air brake pumps and air compressors; new type of automatic water gauges.

Modoc Company of Philadelphia, Pa. This company's exhibit consisted of the perfect car cleaner.

Moran Flexible Steam Joint Company of Louisville, Ky. This exhibit consisted of steam couplers and the Moran flexible joints suitable for steam, gas, air or liquid pressure.

Morse Twist Drill Company of New Bedford, Mass. This company

# Tate Flexible Staybolt



Strong

Effective

Economical

Flexibility

Durability

Simplicity

Holds firebox sheets securely together, and accommodates itself to the unequal expansion of the plates.

## FLANNERY BOLT COMPANY

PITTSBURG, PA., U. S. A.

Suite 308, Frick Bldg.

B. E. D. STAFFORD, - - General Manager  
Write us for Reference Book



**The ALDON COMPANY**  
1103 Monadnock Block  
CHICAGO, ILL.

**ALDON** Car and Engine  
**Replacer**



Save Time, Labor and Damage to Equipment

No Loose Parts to Get Out of Order  
Gradual, Easy Lead to Rails  
A Modern Appliance for Modern Roads

CIRCULAR ON APPLICATION

**Locomotive Engine**  
**Running and Management**

By **Angus Sinclair** \$2.00 Best book in print for any railroad man

**ANGUS SINCLAIR COMPANY**  
136 Liberty Street, New York

exhibited drills, taps and reamers, chucks, cutters, dies, mandrels, gauges and saws.

Nathan Mfg. Company of New York. In this exhibit, which consisted of injectors, lubricators, locomotive fittings, the Phillip's Double, Safety check was shown. This check is intended to be applied to the top of the boiler, and its action is such that water passing through it is sprayed into the steam space in the cylindrical part of the boiler. By the time the water reaches the lower part of the boiler it is hot. The check is in use on a number of railways in the United States, Cuba and Mexico. The Company, also handle the Coale Muffler and Safety valves and a reflex water gauge. This device causes the steam spaces above the water to shine with a silvery luster, while the water itself in the glass shows up black.

National Car Coupler Company of Chicago, Ill. There was on exhibition here a small model of cars equipped with the improved National No. 6 Passenger coupler, also a small model of the Hinson Emergency Knuckle. There was a larger model of passenger platforms with buffer and yoke, also National centering yoke, National steel platforms and passenger vestibule and baggage car buffers.

National Malleable Castings Company of Cleveland, O. This company exhibited the Tower and the Climax freight car couplers. They were mounted on stands which greatly facilitated the examination of the couplers.

New Jersey Tube Company of Newark, N. J. This company showed their patented spirally corrugated tubes with ends reduced for insertion into the flue sheet of the locomotive fire box.

Niles-Bement-Ponds Company of New York. This company had a specially erected booth not far from the Pennsylvania railroad station. Their exhibit consisted in showing a 90-in. extra heavy driving wheel and chucking lathe in regular operation. The machine was equipped with the sure-grip driver attachment, and the rapid work of this powerful lathe was demonstrated to the many interested spectators who came to the exhibit.

Norton, A. O., Inc., of Boston, Mass. This exhibit consisted of a full line of Norton ball bearing jacks, also sure-drop jacks.

The Norton Emery Wheel Company of Worcester, Mass. This company exhibited grinding wheels and samples of grinding material. The artificial abrasive which this company now uses is called Aludum. It is composed of a mineral called bauxite which is a hydrate aluminum. It is reduced in an electric furnace and is cast in the form of ingots which are crushed to suitable

sizes and manufactured into wheels, stones, etc., for grinding and polishing purposes.

Norton Grinding Company of Worcester, Mass. The exhibit of this company was composed of locomotive crank pins, slide valves and piston rods, which had been ground true and smooth. One of the company's grinding machines was part of the exhibit.

Oliver Machine Company of Grand Rapids, Mich. This company's exhibit consisted of photographs of wood working machines of all kinds, also pattern shop machines and supplies.

Post, E. L., & Company of New York. This company's exhibit consisted of "Zero" and "Motor" metals for use in journal bearings.

Power Specialty Company of New York. This exhibit was made up of samples of Duval metallic packing and Foster superheaters.

Pressed Steel Car Company of Pittsburgh, Pa. This company had an exhibit on the tracks of the Pennsylvania railroad, near the station. It consisted of a steel coach built for the Southern Ry. The car is 66 ft. over end sills, 9 ft. 10 1/2 ins. wide, and the height inside is 8 ft. 10 1/4 ins. The car weighs about 110,000 lbs. in all, and the body of the car alone weighs 76,000 lbs. The sides are stiffened by a deep plated girder which extends up to the window sills and the center sills are of the fish-belly type.

Quincy-Manchester-Sargent Company of Chicago. The exhibit of this concern was made up of Ajax diaphragms, models and photographs of the Fewing car and engine replacers, Stanwood car steps, Priest snow flangers and railway repair shop tools, such as boring bars, hoists, cranes, etc.

Ralston Steel Car Company of Columbus, Ohio. The exhibit was on the Pennsylvania tracks at the passenger station and consisted of a modern flush floor drop bottom car. It is fully illustrated and described on page 314 of this issue of RAILWAY AND LOCOMOTIVE ENGINEERING.

Rushmore Dynamo Works, Plainfield, N. J. Electric and acetylene headlights using lens headlight glasses and the Mangin mirror as a reflector, also an acetylene generator and an electric searchlight.

Savage Safety Brake Company of New York, showing the operation of their brake. This was described and illustrated in the February, 1906, issue of RAILWAY AND LOCOMOTIVE ENGINEERING, page 86.

Safety Car Heating and Lighting Company of New York. This exhibit was contained in a tastefully built booth and showed the company's appliances for car heating and lighting, among

**A Practically Perfect Portable Pneumatic**

# PUNCH

Stop moving your heavy work to the machine. One Man brings this tool to the work and punches it besides.



**SAVES TIME LABOR SPACE**

Leading concerns in all parts of the country use this Punch.



**Punch Size 3**

Built in 5 Standard Sizes. Special machines built to order. Write for Catalogue C.

**F. F. SLOCOMB & CO., Builders**  
WILMINGTON, DEL.

which were to be seen modern lamps burning Pintsch gas, four flame Pintsch lamps, Pintsch mantle lamps, which give an exceedingly satisfactory light, being specially constructed for the exacting kind of service met with in railway car lighting. There were also electric fixtures for cars. Two storm proof lanterns for buoys and beacons were on exhibition, one a red and one a white light, both were intermittent, giving steady and powerful glow for some seconds and dying down until only the minute lighting flame burned. These buoy lanterns were equipped with beautifully made Fresnel lenses, which concentrate the light in what one might call a flat cake or disk of light, which spreads out level over the sea and in the center of which the Pintsch gas flame burns.

Schoen Steel Wheel Company of Philadelphia. Seamless steel wheels made after the Schoen method were on view; steel disks, as they appeared in the earlier stages of the process, were exhibited. Two pairs of wheels exemplified the wear which took place before the first turning and one pair was an example of the design ordered by the government of Japan. The exhibit was interesting, as it was practically an object lesson on the evolution of this make of steel wheel. All the wheels shown were of course Schoen.

Sellers & Company of Philadelphia exhibited their well known injectors, among which were the improved automatic non-lifting variety, also the automatic re-starter, non-lifting kind. Main check valves, stop and angle valves were also on view.

Simplex Railway Appliance Company of Chicago showed the Andrews cast steel side frame for trucks, Davis wheels, bolsters, brake beams, Janney couplers and various steel castings.

Slocomb & Company, F. F., of Wilmington, Del., displayed a hot air pumping engine and a hydro-pneumatic riveting machine.

Sprague Electric Company of New York had on exhibition electric hoists, vertical dock winch, flexible steel conduits, steel armored conductors, steel armored flexible cord outlet boxes and fittings for conduits; steel hose for air or steam pressure.

Standard Coupler Company of New York exhibited a steel platform and Sessions standard friction draft gear. This company made use of the moving picture idea to illustrate the action of their friction gear and gave away a neat little pocket souvenir. It is a thumb book 2 3/4 ins. long by 1 1/4 ins. wide, with card pages, sufficiently stiff to spring readily under the sliding thumb. There are eighty excellent half-tones showing the draw gear with stops, springs, followers and friction mechanism in place;

as the "continuous" picture is looked at follower runs in, pushing the triangular pieces against the side wedges and so bearing against the central wedge which, when backed against the spring, causes the whole system to yield to the heavy buffing shocks to which modern draw gear is exposed. The company will give this silent pocket demonstrator to anyone who writes to their office at 160 Broadway, New York.

Standard Paint Company of New York had a very tasteful exhibit surrounded with a miniature hedge in bloom. A miniature cottage showed the use to which their Ruberoid roofing could be put, as well as its general use for covering box cars, engine cabs and station buildings. The cottage also showed the quality of the standard paints among which were flexible metal preservative paints, Giant and P. & B. insulating papers, S. P. C. boiler and smoke stack paint, P. & B. baking and drying varnishes, red and brown Ruberoid roofing.

Standard Steel Works of Philadelphia had a 33-in. bolted section wrought spoke wheel, with a part cut away on the rim, also a bolted section wheel with cast spokes, a cast iron plate wheel bolted section, also a rolled steel wheel with section cut out, bent sections of rolled wheels and a variety of springs.

Star Brass Mfg. Company, Boston, Mass., showed locomotive pop valves, plain and muffled. Non-corrosive steam and duplex air gauges, cylinder relief valves and chime whistles. There were also on exhibition Seibrighnt bull's eye lubricators, cylinder cocks, steam gauges, air gauges for brake inspectors, globe and angle valves with renewable seats, blow-off cocks, indicators with inside and outside springs.

Starrett Company, L. S., of Athol, Mass., exhibited a large variety of fine tools for mechanics' use; such as steel rules, squares, calipers, dividers, micrometers, steel tapes, drawing instruments, etc., etc. Their display of hacksaw blades was particularly good and attracted much attention.

Symington Company, T. H., of Baltimore, Md., showed the Symington journal box, of standard and special design, boxes for high speed electric service, Baltimore ball bearing center plates and side bearings.

Talmage Manufacturing Company, Cleveland, Ohio. This exhibit booth, which was tastefully and comfortably fitted up, contained the Talmage blow-off valve. The representatives gave a general explanation of the Talmage system of washing out and care of boilers. Rubra boiler oil for use in the feed water of locomotives, and numerous blue prints showing the method of application of the whole apparatus to locomotives were shown. The bad water problem is com-

## THE ELASTIC SELF-LOCKING STEEL NUT



Blank Cut from Flat Bar of Steel



2nd Operation



Finished Nut

The elastic nut positively locks itself on the bolt wherever placed, and cannot work loose. Send for Circulars.

Quincy, Manchester-Sargent Co.

Old Colony Building  
CHICAGO

114 Liberty Street  
NEW YORK

## SKAT

is a soft soap sold in a neat lithographed can. When you wash up with SKAT, it gets into the crannies and "hard to reach" corners of your hands and the results are surprising. That's where the dirt licks and hard soaps won't go. That's why SKAT is so popular. SKAT is made of the best materials, is absolutely pure and guaranteed to give you perfect satisfaction. You'll use it every day and like it more each time.

We can tell you where to buy SKAT, or better still show you how to sell it. If SKAT is not for sale in your locality, let us give you the selling right. Drop us a postal and get a free sample.

**SKAT MFG. COMPANY**  
Hartford - Conn.

## Flexible Spout

Vertically in straight line. Also laterally. The latest improvement to

## Poage Water Columns

American Valve and Meter Company

CINCINNATI, OHIO

—SEND FOR CATALOGUE—

## Compound Locomotives

By FRED H. COLVIN, M.E. Tells everything an engineer needs to know about all kinds of American compound locomotives. \$1.00.

ANGUS SINCLAIR COMPANY

136 Liberty Street

New York

# One Year and Eleven Months'

## SERVICE

WITHOUT REPACKING, ON

## HIGH-PRESSURE LOCOMOTIVES

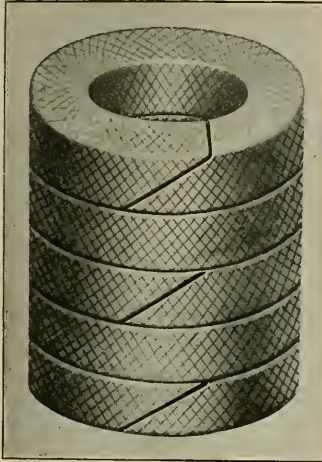

Style 300 TV.

A throttle failure is an absolute impossibility where Crandall's Throttle Valve packing is used.

IT WILL NOT BLOW OUT

## Crandall Packing Co.

FACTORY AND GENERAL OFFICE

PALMYRA, - NEW YORK

BRANCHES

New York  
136 Liberty St.

Cleveland  
9 So. Water St.

Chicago  
52 West Washington St.

# Patents.

GEO. P. WHITTLESEY

McKILL BUILDING WASHINGTON, D. C.

Terms Reasonable. Pamphlet Sent

## Molding Machines

Vertical Vibration. Power Draft

ALL KINDS OF MACHINES

THE E. H. MUMFORD CO.

17th & Callowhill Streets, PHILADELPHIA, PA.  
J. W. JACKMAN & CO., Ltd., 29 Victoria St., London, S. W.

prehensively dealt with by the Talmage system.

Trojan Car Coupler Company of New York exhibited the Junior coupler.

Tyler Tube and Pipe Company of Washington, Pa., showed knobbled iron boiler tubes, also photographs illustrating the growth of the company.

Underwood & Company, H. B., of Philadelphia, Pa., had an extensive exhibit of locomotive repair shop appliances, among which were their portable boring bar for the re boring of cylinders, portable rotary planing machine for facing valve seats, portable crank pin turning machine, portable dome or joint facing machine. Lathe attachment for boring and a two-cylinder motor for air or steam used in driving the portable shop tools made by the company.

United States Light & Heating Company of New York. Axle lighting system for electric lights in passenger equipment. The storage battery, however, was not shown.

U. S. Automatic Heat Regulating and Ventilating Company of Newburgh, N. Y., had a car on the Pennsylvania tracks in which they showed their thermostatic method of railway car heat control. The demonstrating car had been in service on the N. Y., O. & W., and the device is a clever adaptation of physical laws to produce the desired result.

Vacuum Cleaner Company of New York. This company gave a practical demonstration of car cleaning in a coach placed on the exhibition tracks near the Pennsylvania station. The vacuum system is one by which dust and dirt is sucked up into a rubber hose, through a specially made mouthpiece, which can be run over cushions or carpets when in the hands of an attendant. The dirt is literally pumped out of the car and not brushed from one object to another. A vacuum cleaned car is clean.

Wells Light Mfg. Company of New York showed the Wells light in three sizes, suitable for supplying a powerful light in all weathers in railroad wrecking operations. They also showed the Wells standard oil gas lamp and Wall-work's Universal electric lamp brackets.

Westinghouse Air Brake Company had a most interesting and extensive exhibit, showing their latest appliances. There was an air brake equipment for two freight trains each of 75 cars, one showing the standard automatic equipment and the other, the improved quick service, retarded release, retard recharge style of triple, known as the "K" triple valve, also the E. T. equipment. Cross compound air pump for locomotive, friction draft gear, etc., etc.

Whitney Mfg. Company of Hartford, Conn. High grade driving chains, cutters and keys for the Woodruff system of keying. Presto chucks, callets and friction tapping devices, etc.

During the Master Mechanics' convention the Baldwin Locomotive Works chartered a P. & R. special train of six coaches to take members and their friends to Philadelphia and return. The train left at 12.30 P. M., returning at 5.45 P. M. On arrival at Philadelphia the train was met by a number of tally-ho coaches and carriages and the party was driven to the works where a delightful lunch was served in an improvised room tastefully decorated for the occasion. After lunch the party was escorted over the works. Nothing could exceed the kindness and courtesy of the officers of the great locomotive building establishment, and the trip was thoroughly enjoyed by all who had the privilege of participating in it. The distance between Camden and Atlantic City is 55 6/10 miles and there are three short 60 ft. grades on the road and several curves. The engine used on this occasion was a 4-4-2, designed by Mr. H. D. Taylor, superintendent of motive power of the Philadelphia & Reading. It has 22x27 in. cylinders and 84 in. drivers. Going to Philadelphia the distance was covered in 45 minutes or at an average speed of 75 miles per hour. The return trip, however, was the faster of the two. Leaving Camden the Atlantic City racer got into her stride in short order, and though several miles were wheeled over at top speed the average made along this fine double-track block signaled speedway of the iron horse was at the rate of 78 3/4 miles per hour. Just 43 minutes after leaving Camden the train halted at the city by the sea and the convention run for 1906 was a matter of record.

### Torsional Strength.

The twisting or torsional strength or resistance of a wrought iron bar is generally measured by the load it will sustain at the end of a lever projecting therefrom, the bar being held against rotation. The bar of iron should stand not less than 700 lbs. suspended at the end of a lever one foot long. It should be borne in mind that the twisting strength varies with the cube of the diameter of the bar. Thus the torsional strength of a bar two inches in diameter has eight times that of a bar one inch in diameter. The area of the former is four times that of the latter, and although the diameter is but doubled, the actual quantity of metal is increased four times. Swedish iron, although possessing high magnetic permeability, has a low resisting power to torsional strains, and hence is unsuitable for services where toughness rather than softness is required.

The first business of the philosopher is to part with self-conceit.—Epictetus.

### Resaw for General Work.

The band resaw shown in our illustration is designed for all kinds of general work and as it runs the lightest blades, all work is accomplished with a great saving in kerf. The column of the machine is a single-cored casting which will stand any reasonable strain without vibration. The wheels are 50 ins. in diameter, the lower one being solid gives increased momentum, helps to reduce friction, as it is well balanced. The wheels run between large self-oiling, non-dripping reservoir bearings.

The feed consists of four 5-in. rolls, strongly geared. There are two guides, one above and one below the board. Stock of any width up to 30 ins. can be resawed. The rolls open 13 ins. wide, the outer ones 8 ins. from the saw and the inner ones 5 ins. Thus thin sheets may be sawed from the side of a stick of timber 8 ins. thick or a 5-in. piece taken from a piece of timber 13 ins. thick. This machine is made by the J. A. Fay & Egan Co., Cincinnati, Ohio.

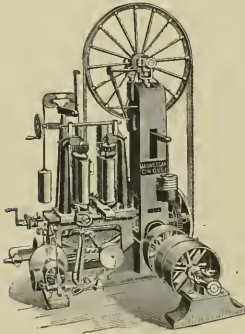

GENERAL WORK RESAW.

and complete information, with price, etc., may be obtained on direct request to them. When writing, also ask for circulars concerning other wood-working machines or for their general catalogue if you desire the information which these contain.

### The Helping Hand.

Cato said that "You must begin by being nothing if you are going to be something great." We cannot all be great, but we can all learn something and fit ourselves for our vocation, and, to the measure of our ability, grasp the opportunities that come to us. Railroad men have much to learn in order that they may master their high calling, but RAILWAY AND LOCOMOTIVE ENGINEERING endeavors to make the task easy. Thousands acknowledge it as the best helping hand to them in their efforts to become accomplished railroad men. Its growing popularity shows that it is keeping pace with the requirements of the

times. Its pages are filled with expressions of the best thought which comes from the leading railroad men of our time. It has merited the highest encomiums from prominent railway men all over the world. The price, \$2 a year, places it within the reach of every railroad employee.

"Twentieth Century Locomotives," Angus Sinclair Co., deals comprehensively with the design, construction, repairing and operating of locomotives and railway machinery. First principles are explained. Steam and motive power is dealt with; workshop operations described, valve motion, care and management of locomotive boilers, operating locomotives, road repairs to engines, blows, pounds in simple and compound engines; how to calculate power, train resistance, resistances on grades, etc. Shop tools explained. Shop recipes, definitions of technical terms, tables, etc. Descriptions and dimensions of the various types of standard locomotives. The book is well and clearly illustrated and is thoroughly up to date in all particulars, fully indexed. Price, \$3.00.

"Locomotive Engine Running and Management," by Angus Sinclair, is an old and universal favorite. A well-known general manager remarked in a meeting of railroad men lately, "I attribute much of my success in life to the inspiration of that book. It was my pocket companion for years." Price, \$2.00.

"Practical Shop Talks," Colvin. This is a very helpful book, combining instruction with amusement. It is a particularly useful book to the young mechanic. It has a stimulating effect in inducing him to study his business. We sell it for 50 cents.

"Examination Questions for Promotion," Thompson. This book is used by many master mechanics and traveling engineers in the examination of firemen for promotion and of engineers likely to be hired. It contains in small compass a large amount of information about the locomotive. Convenient pocket size. We cordially recommend this book. It sells for 75 cents.

The 1904 Air Brake Catechism. Conger. Convenient size, 202 pages, well illustrated. Up-to-date information concerning the whole air brake problem, in question and answer form. Instructs on the operation of the Westinghouse and the New York Air Brakes, and has a list of examination questions for engine-men and trainmen. Bound only in cloth. Price, \$1.00.

"Compound Locomotives," Colvin. This book instructs a man so that he will understand the construction and operation of a compound locomotive as well as he now understands a simple engine. Tells all about running, break-

## WASHBURN COMPANY

Minneapolis, Minn.

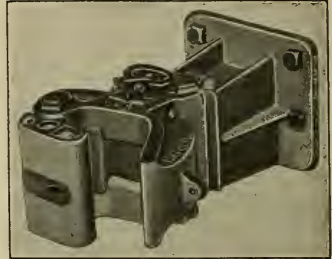

Automatic couplers for freight, engine and passenger service.

Draft riggings and buffer attachments for freight and passenger cars.

Special couplers for narrow gauge and plantation service a specialty. Steel castings of all descriptions.



## The Twentieth Century Master Mechanic

Won't use Solid Mandrels. Cost too much, take up too much room and don't give satisfaction.

### Nicholson Expanding Mandrels

Take everything from 1 to 7 inch holes. Take up little room—always ready and you can buy four sets for the cost of one of the solid kind

### Are You Using Them?

Catalogue tells you more about them.

W. H. Nicholson & Co.  
Wilkesbarre, Pa.

# World's Fair

## St. Louis

### FIRST PRIZE FOR

# TOOL STEEL

### AWARDED TO

## McInnes Steel Co.

### CORRY, PA.

in competition with the best makes in England and Germany. Also manufacturers of all kinds of Tool Steel, Die Blocks, and Steel Forgings.

Write for Prices and Information

STANDARD MECHANICAL BOOKS  
FOR ROAD AND SHOP MEN  
BY CHAS. McSHANE

## The Locomotive Up to Date

Price, \$2.50

## New York and Westinghouse Air Brakes

Price, \$1.50

## One Thousand Pointers for Machinists and Engineers

Price, \$1.50

All books bound in fine cloth

AGENTS WANTED everywhere; write for terms and descriptive circulars. Will be sent prepaid to any address upon receipt of price.

**GRIFFIN & WINTERS**  
171 La Salle Street, CHICAGO

downs and repairs. Convenient pocket size, bound in leather, \$1.00.

"Catechism of the Steam Plant." Hemenway. Contains information that will enable a man to take out a license to run a stationary engine. Tells about boilers, heating surface, horse power, condensers, feed water heaters, air pumps, engines, strength of boilers, testing boiler performances, etc., etc. This is only a partial list of its contents. It is in the question and answer style. 128 pages. Pocket size, 50 cents.

### Compound 4-4-2 on the Great Northern.

Our illustration shows a good example of a compound express engine recently built for the Great Northern Railway of England, of which Mr. H. A. Ivatt is the company's locomotive engineer. The engine, which is a four-cylinder compound of the 4-4-2 type, has cylinders 14 and 23 by 26 ins.

The high pressure cylinders are on the outside and have piston valves, while the low pressure cylinders placed

it. is augmented by the fact that the internal ribs add considerably to the area exposed to the heated gases passing through. The material of the fire box is copper, and the box gives a heating surface of 170 sq. ft. Although the heating surface does not comprise as large an area as many of our engines do, it is very effective. The diameter of the boiler is 5 ft. 1 $\frac{3}{8}$  ins. at the front end.

The engine presents a neat and compact appearance, and was built by the Vulcan Foundry Company, Ltd., at their locomotive works at Newton-le-Willows in Lancashire. A few of the principal dimensions follow:

Boiler—Thickness of plates, 11/16 in.

Fire Box—Length, 0 ft.; width, 4 ft. 10 $\frac{1}{2}$  ins.; depth, front, 6 ft. 4 $\frac{1}{2}$  ins.; depth, back, 4 ft. 9 ins.

Thickness of Plates—Sides,  $\frac{5}{8}$  in.; back,  $\frac{3}{4}$  in.; crown,  $\frac{5}{8}$  in.; tube 1 in.

Driving Wheels—Journals, 8 $\frac{3}{4}$  ins. by 9 ins.

Engine Bogie Wheels—Diameter on tread, 3 ft 2 ins.; journals, 5 $\frac{3}{4}$  ins. by 9 ins.

Trailing Wheels—Diameter, 3 ft. 8 ins.; journals, 5 $\frac{1}{2}$  ins. by 10 ins.

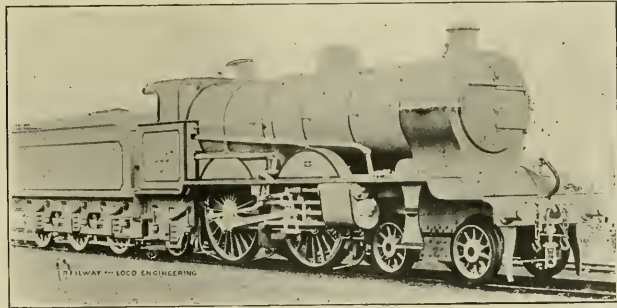

COMPOUND 4-4-2 ON THE GREAT NORTHERN OF ENGLAND.

below the smoke box are supplied with Richardson slide valves. Walschaerts valve gear is used in connection with the high pressure cylinders. The little valve which can just be seen nestling close behind the chimney is the outlet for the safety valve from the low pressure steam chest.

The engine has two reach rods, one for the high and one for the low pressure valve gear. The driving wheels are 80 ins. in diameter. The weight on the drivers is about 37 tons, the leading bogie carries 20 $\frac{1}{4}$  tons and the trailing wheels 13 $\frac{3}{4}$  tons, so that the total weight of the engine is, therefore, 71 tons. The total weight of engine and tender is 112 tons. All these are long tons of 2,240 lbs. each.

The boiler carries a pressure of 200 lbs. and has a total heating surface of 2,514 sq. ft. and a grate area of 31 sq. ft. Serve tubes are used. There are 149 of them and they are 2 $\frac{3}{4}$  ins. in diameter, 12 ft. 4 ins. long. The heating surface of the tubes, which is 2,344 sq.

Wheel Base—Driving, 8 ft. 6 ins.; rigid, 15 ft. 3 ins.; total, engine, 23 ft. 3 ins.; total, engine and tender, 49 ft. 6 ins.

Tender—Diameter of wheels, 4 ft. 2 ins.; tank capacity, 3,650 Imperial gallons; tender, loaded, 41 tons.

Service—Fast passenger.

### Inspecting Castings.

A painted casting is a proper object of suspicion. The face from which the metal was poured is where the closest scrutiny should be observed. This can readily be distinguished by the cutting off marks. Air bubbles, and light matter rise to the surface, and it is in the upper surfaces that blow holes will likely occur. The suspected surface should be tapped lightly with a hand-hammer, and a thin film of metal is readily broken through. A hollow sound readily indicates the presence of a defect, even if it does not break readily.

Small holes should be probed with a flexible wire. Indications of chipping or filing marks are a sure sign that a swelling had been there and more than likely the mark of a hollow within. A

# Locomotives, Freight and Passenger Cars

All equipment rebuilt in our Chicago shops, and at Scranton, Pa., in the new "Lackawanna" Shops

## All Kinds of Cars and Engines Ready for Immediate Delivery

RELEASED BY TRUNK LINES

1000—60,000 LBS. CAPACITY REBUILT FLATS AND GONDOLAS  
 2000—50,000 LBS. CAPACITY FLATS, BOX AND GONDOLAS  
 COACHES, COMBINATION AND BAGGAGE CARS  
 FOREIGN SHIPMENTS HAVE PROPER CARE OF  
 EXPERIENCED STAFF

Cable Address  
 "FITZLUTH"

55 AND 70 TONS CONSOLIDATIONS  
 45 AND 50 " 10-WHEELERS  
 40 TO 55 " MOGULS  
 45 TO 50 " PASSENGERS  
 SWITCHERS, FORNEYS AND SHAY ENGINES.

**FITZ-HUGH, LUTHER CO., Monadnock Block, CHICAGO**  
 141 BROADWAY NEW YORK      CHEMICAL BLDG. ST. LOUIS      80 ST. FRANCIS XAVIER ST. MONTREAL, CAN.      RIALTO BLDG. SAN FRANCISCO

scab is an indication that a portion of the sand had fallen and lodged somewhere in the metal. Holes need not necessarily condemn a casting. It depends on their location. Holes in the bottom of a lathe-bed would not render it useless, but holes in the upper portion would. The hammer test in skilful hands is also a means of showing the elasticity of the metal. The sound of brittle metal is pitched in a higher key than metal of a softer or more ductile kind.

### Stevens Institute.

The thirty-fourth annual commencement exercise of the Stevens Institute of Technology was held in the Auditorium of the Institute at Hoboken, N. J., on June 14. The President, Alex. Humphreys, LL.D., read the annual report, showing an attendance of 422 students with a graduating class of 76. The report shows a steady growth of attendance until the limit of the Institute has now been nearly reached. The president closed with an eloquent address on the importance of engineering. The salutatory address by Mr. M. G. Farrell, was a masterly oration on the dignity of labor and the important part that engineering took in facilitating the most difficult mechanical undertakings.

The degree of Mechanical Engineer was then conferred on the 76 graduates; and the Honorary Degree of Doctor of Engineering was conferred on J. H. Hammond, Professor of Mining Engineering at Yale University, also on D. S. Jacobus, M.E., Professor of Experimental Engineering at the Stevens Institute, and also on J. E. Denton, M.E., Professor of Engineering Practice, Stevens Institute.

Nearly two thousand people were present, among whom were many distinguished engineers. The standing of the graduates is said to be exceptionally high, and it would certainly be difficult to see a finer body of young men assembled together. Their scholarly at-

tainments are undoubted, but their athletic abilities, we are sure, are still higher. They looked as if ready to compete for the Pentathlon wreath.

### Alfalfa.

The vast country opened up by the Santa Fe Railroad is at this season of the year particularly full of wonder and beauty. The fields of alfalfa thick with its variegated blossoms surpass in beauty the clover blooms of New England or the orchards of Maryland. Its blossoms are perennial and although it reaches its brightest beauty in the early summer, it seems to grow forever and four or five crops a year are regularly reaped. No plant has so much water sense as alfalfa. It reaches its roots deep down into the soil, ten or fifteen feet deep, to the water sheet which underlies all the vast southwestern country two or three hundred miles from the mountains. The night winds give it vigor and the warm sun sweetens its juices. The rain may come as it chooses, the alfalfa has its own irrigation works in the waters under the earth.

In addition to this wonderful plant every kind of fruit and vegetable grows in abundance in the region reached by the Santa Fe. It is impossible for any one to comprehend, even to a small degree, the yielding powers of these soils when they are put into proper physical condition. The climate is clear, dry and invigorating, with cool nights that give restful sleep. The general altitude of the great plains approaches 4,000 ft., or about the height of the highest of the Catskill Mountains. The great Santa Fe Railroad has opened up a veritable Garden of Eden.

A unit of heat is the quantity of heat required to raise the temperature of one pound of pure water from 39 to 40 degrees. This is on the Fahrenheit thermometer and there are 778.3 foot-pounds in every heat unit.

## METAL PRESERVATIVE PAINTS AND PRIMER

for locomotives, boilers, stacks, front-ends, gearing, frame-work, metal roofs, etc.  
 Tell us your needs.  
 Metal preservative paints have been our specialty for 22 years.  
 Paints for all conditions.

THE  
**STANDARD PAINT CO.**  
 Sole Manufacturers  
 100 William St., New York  
 CHICAGO      ST. LOUIS

### CONTENTS:

	PAGE.
Air Brake Dep't.....	325
B. & O. Motive Power.....	330
British Notes and News, A. F. Sinclair.....	304
<b>Cars:</b>	
*Flush Floor Drop Bottom.....	314
*Special Steel Flat.....	328
Convention Exhibits.....	338
Cost Per Mile Run.....	333
<b>Editorials:</b>	
Light Losses from a Headlight.....	318
Timber for Railway Ties.....	316
Modern Machinists.....	317
Repair Shop Savings.....	317
General Foreman in M. M. Ass'n.....	318
<b>Engine Failures.....</b>	<b>303</b>
*Engulfing a Waterfall.....	304
Fuses, Leaky, Cause of.....	303
Front End Locomotive.....	330
General Correspondence.....	309
<b>Locomotives:</b>	
*Simple 2-8-2 for L. C. & M.....	307
*Simple Tunnel Locomotive.....	308
*Historic.....	313
*Compound 4-2 Great Northern.....	352
*Mountain Climber in Burma.....	335
4-6-2 for the B. & O.....	329
Locomotive Engineer, To become a.....	319
Our Correspondence School.....	321
Personals.....	333
*Statue of Baldwin.....	333

# Railway and Locomotive Engineering

Copyright by Angus Sinclair Co.—1906

A Practical Journal of Railway Motive Power and Rolling Stock

Vol. XIX.

136 Liberty Street, New York, August, 1906

N. J. 8

## Cantilever Bridges.

Probably the oldest form of bridge in the world was the trunk of a fallen tree stretching across a narrow gorge, and the familiar example of a plank thrown across a stream is for most people the

separately or both together, always exerts a downward thrust on the abutments or piers of the bridge.

The cantilever bridge, however, modifies this original conception and has introduced another principle into bridge

lever, and as it plays a very important part in the make-up of the bridge, the name is applied to that class of bridges which contain cantilevers.

The typical form of cantilever bridge is represented in the diagram Fig. 1,



CANTILEVER BRIDGE OVER THE FRASER RIVER, C. P. R., BRITISH COLUMBIA.

fundamental conception of bridge construction. It is in essence a beam supported at each end and carrying whatever load may be put upon it, along its upper surface. The form of the bridge may vary from the old stone arch to the modern steel girder, but one general conception prevails in most minds, and that is, that the pressure of the structure itself, and of the load it carries,

construction. It is briefly that the reaction of the load on such a bridge causes, not a downward, but an upward pressure at the abutments or shore ends. The word by which this newer form of structure is described is made up with the first syllable "cant," which here signifies an inclination from the horizontal, or a slope or set. The cantilever is thus nothing more or less than a sloping

and this shows two towers supporting horizontal girders each somewhat resembling the upright stem of the letter T, with an evenly balanced crosspiece on top. In the diagram, *A* and *Z* are the shore ends or abutments of the bridge, *B* and *Y* are the tops of the towers or piers, and *CX* is the suspended or connecting girder in the center. In this case the cantilevers are the

girders *BC* and *XY*. They are the sloping levers from which this style of bridge takes its class name. With a bridge of this form it is evident that any load borne between *A* and *B* or between *Y* and *Z* will cause a downward pressure upon the shore ends *A* and *Z* and also upon the piers *B* and *Y*.

rection, no supporting false work is needed. When each *T* has been built and the shore ends of the trusses have been anchored down, the suspension truss in the center is built out from each cantilever and connected above mid-stream without support from below. A cantilever bridge might be built with-

RAILWAY AND LOCOMOTIVE ENGINEERING, Mr. C. C. Schneider, of Philadelphia, the designer of the beautiful steel structure in British Columbia, and of the Niagara river bridge, quotes from London Engineering as follows:

"The Fraser river bridge crosses the Fraser river six miles below Lytton. The river here thunders through a rocky canyon one hundred and twenty-five feet at ordinary high water below the level of the rails, but when the summer floods are passing through, its height is then sixty feet above this, and the uproar of its torrent is something fearful. The erection of anything like a scaffolding or false work in this situation was out of the question, and hence the advantage and propriety of the cantilever system, by which temporary construction across the river was unnecessary. This would have been the first bridge on this principle erected in America had it not been for the very long time that was occupied in bringing the iron across the Atlantic, the vessel occupying within two days of six months on the voyage, during which time the Canada Southern bridge across the Niagara was ordered, built and opened for traffic. The span of the Fraser river bridge, from center to center of the cantilevers, is three hundred and fifteen feet. The two levers are each two hundred and ten feet long, and they carry between them a girder one hundred and five feet long, so that from the anchorage at each end the truss support is five hundred and twenty-five feet long. The center of each cantilever is carried by a stone pier seventy-two feet high from the rock on the river bank, and the outer ends of the levers are held in position by an anchorage in the abutment founded on the solid rock of the river bank. The total weight of steel and iron in the structure is 1,224,000 lbs. The strains are calculated to carry a train the full length of the bridge, weighing 2,500 lbs. to the foot, running length, with two locomotives at the head, each weighing 55,000 lbs. on three pairs of drivers, not over fourteen feet wheel base in addition. The wind strain is calculated for the full surface of both trusses and a train showing a side exposure of ten feet in height and the full length of the bridge. The bridge work was made by Hawks, Crawshaw & Company, of Gateshead-on-Tyne."

Mr. Schneider further remarks: "From this it appears that the Fraser river bridge was completed in 1884, while the Niagara cantilever bridge was commenced in 1883 and completed in the same year. The erection of the Fraser river bridge was done under the supervision of Mr. Joseph Tomlinson, bridge engineer of the Department of Railways and Canals of Canada."

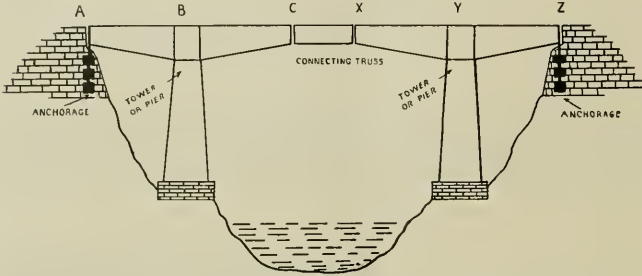

FIG. 1. SKELETON VIEW OF TYPICAL CANTILEVER BRIDGE.

As the load moves out onto either of the cantilevers, *BC*, or *XY*, the resultant pressures change, so that although the thrust at *B* and *Y* are still downward, those at *A* and *Z* are now upward, and are resisted by an anchorage system which ties the shore ends of the bridge down firmly to the abutments. The general form of anchorage is shown in Fig. 2. A load anywhere on the connecting span *CX* is carried in due proportion to the cantilevers, and produces a downward pressure upon the piers and an upward pull at the abutments. The construction of the bridge is such that a load placed anywhere on the truss *XZ* does not produce any effect on the truss *AC*, and vice versa, because each girder is, so to speak, self contained and is capable of fully sustaining its own load. The girders are usually made with some form of sliding connection at *C* and *X*, so that the effects of expansion and contraction, and, in fact, no horizontal strain, will be transmitted from one *T*-system to the other. In Fig. 3, the slotted pin holes are shown at the top and bottom of the outermost diagonal members of the cantilevers.

Cantilever bridges are the most suitable form of structure for spanning rivers which flow through gorges with high precipitous banks and where the current is rapid and turbulent. The reason for this is that no false work or scaffolding is necessary to be used in the process of building, and, as a rule, the foundations of the piers can be placed upon the river bank close to the water. The bridge builder, after erecting a tower, constructs the two portions of the truss piece by piece, from each side. As the river arm stretches out over the flood, the shore arm reaches toward the abutment, and as each extension balances a similar one in the opposite di-

out the central span if the river arms were made long enough to reach each other, and the advantages of the system, and the principle of construction, would be preserved.

Our frontispiece shows a view of the Fraser river bridge on the Canadian

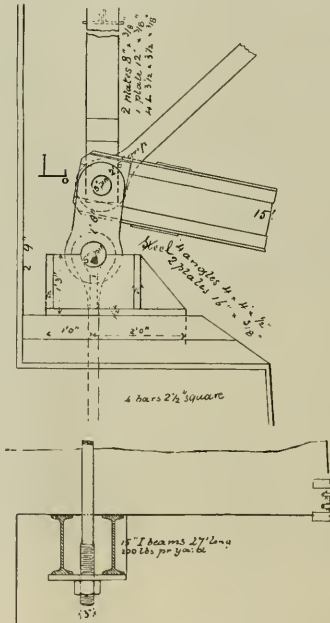

FIG. 2. ANCHORAGE SYSTEM, FRASER RIVER BRIDGE.

Pacific Railway. This was the first cantilever bridge begun on this side of the Atlantic. The bridge over the Niagara gorge though commenced later, was completed sooner. In writing to



The bridge referred to in the foregoing as on the line of the Canada Southern, crosses the Niagara river close beside the magnificent steel arch built by the Grand Trunk Railway, which superseded their famous suspension bridge at that point. The Canada Southern is now part of the Michigan Central Railroad, and the structure in question is a double-track, deck cantilever bridge, which was completed December 1, 1883. The total length of the bridge proper is 895 ft.; length of cantilevers, 375 and 395 ft., respectively; length of fixed span, 125 ft.; length of clear span across the river, 500 ft.; height of abutments, 50 ft.; height of steel towers, 130 ft.; height of clear span above the river, 245 ft.; total weight resting on the steel columns, 1,600 tons.

Concerning the famous Cantilever bridge in Scotland a writer in the *Locomotive Journal* (Leeds, England) quotes a few words from a lecture given by Mr. Baker, one of the engineers of the Forth bridge, before the Royal Institute. The "living model" of the bridge, Fig. 4, is reproduced from the same source. Speaking of the great engineering work which spans the Firth of Forth, he said:

"The great Forth bridge is the first bridge on the 'cantilever and central girder' principle that has been erected in Great Britain, although the principle is by no means new, for it has been adopted hundreds of years ago by comparatively rude tribes in the construc-

Two men seated on chairs extend their arms and hold in their hands sticks of which the other ends butt against the chairs. The central girder is represent-

pressing force, and the weight of the whole is borne by the legs of the chairs, also under compression. Now let the reader imagine the men's heads to be



DOWN STREAM VIEW OF FRASER RIVER CANTILEVER.

ed by a shorter stick, suspended at *a* and *b*. We have here the representation of two double cantilevers, the ropes at *c* and *d*, connected with the weights, representing the anchorages of the landward arms of the cantilevers. When a

360 ft. above the ground, and about a third of a mile apart, while the difference between *a* and *b* is 350 ft., and he will have a rough but sufficiently clear idea, not only of the principle upon which the Forth bridge is constructed, but also the magnitude of one of its spans. To complete the comparison, suppose that the pull upon each arm of the men is equal to 10,000 tons, and that the legs of each chair press on the ground with the weight of more than 100,000 tons."

The dimensions of the Forth bridge are: Length, 8,296 ft., or more than 1½ miles; two spans, each, 1,700 ft.; two spans, each, 675 ft.; depth of main girders at piers, 330 ft.; depth at center, 50 ft.; width of bridge at piers, 120 ft.; width at center, 27 ft.; clear headway for navigation at high water, 150 ft.; deep-est foundation below high water, 99 ft.; highest part of bridge above high water, 354 ft.; depth of water in center of channel, 210 ft.; weight of steel used in construction, 42,000 tons.

One of the latest bridges of the cantilever type is in Africa, and spans the famous Zambesi. This river is two miles wide where it reaches the western borders of Rhodesia. There it precipitates itself into a cavernous gorge. The river and the bridge are thus described by Sir Percy Girouard writing in *Scribner's Magazine*:

"This great drop in the river has produced 'the most beautiful gem of the earth's scenery,' the Victoria Falls. Almost twice as broad as Niagara, and two



DOUBLE TRACK CANTILEVER BRIDGE OVER THE NIAGARA GORGE.

tion of timber bridges, to which it readily lends itself. Such bridges are described as having been erected by the natives of Hindustan, China, Thibet, etc., even at remote periods. A living model shows the general arrangement,

weight is placed on *a b*, which is done in the 'living model' by a third man seating himself thereon, a tensile strain comes into action in the ropes and in the men's arms, while the sticks abutting on the chairs have to resist a com-

and a half times as high, an immense mass of water rolls over its edge to precipitate itself in magnificent splendor four hundred sheer feet into the narrow canyon below.

"Undeterred, the Rhodesian engineers have, without detracting from the natu-

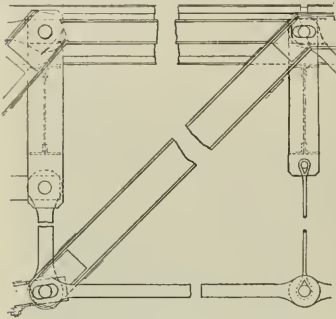

FIG. 3. PANEL WHERE CONNECTING GIRDER JOINS CANTILEVER SPAN, FRASER RIVER BRIDGE, SHOWING OBLONG PIN HOLES FOR EXPANSION.

ral beauty of the surroundings, thrown across the canyon a splendid 650 ft. cantilever bridge and thus opened the way to Tanganyika, to Uganda, to Cairo.

"This bridge, the greatest railway engineering triumph of Africa, consists of a central span weighing approximately 1,000 tons, 500 ft. in length, and 30 ft. wide. The steel work is of rolled sections. The end posts of the bridge are over 100 ft. long. The pull on the anchorage apparatus is about 400 tons."

There is another application of the cantilever principle which is sometimes made use of in bridge building. It is often applied in the construction of the bridge itself but does not, therefore, constitute the structure one of the class known as cantilevers.

An example of this may be found in the C. P. R. bridge over the St. Lawrence river at Montreal. This is a deck



BLACK RIVER SWING, ON THE NICKEL PLATE. CANTILEVER FOR THE DEAD LOAD, CONTINUOUS GIRDER FOR THE LIVE LOAD.

bridge with the exception of the two channel spans which are through girders, and these are cantilevers as far as their method of construction and the balancing of their weight is concerned. Speaking of this feature, the Dominion Bridge Company, of Montreal, builders of the bridge, whose artotype we reproduce, in a letter to the late

Marcus Smith, C.E., who was at one time Canadian government inspector of bridges, said: "The main channel spans of the St. Lawrence river bridge are partly cantilevers and partly continuous with the flanking spans; that is to say, the spans were so designed that for convenience of erection they might be erected as cantilevers, and, consequently, the dead load of the metal work is carried by the cantilever action as they were erected in this way, and no stress was put in the central chord section when the connection was made. The trusses were, however, proportioned on the assumption that they would carry the live load as continuous girders and the connections of the closing section were made in accordance therewith. The spans are, therefore, continuous with regard to live load and cantilevered with regard to dead load."

Thus we see that the cantilever principle though not a new one, has had its modern application in the building of some most magnificent bridges and the principle so applied has marked a very important step in the advancement of the art.

#### Why Johnson Wasn't Fired.

BY R. E. MARKS.

There was a new superintendent on the Cross Cut & Pumpkin Valley Railroad, who was long on a liking for things scientific, reports of tests, college bred engineers and other things, but he was somewhat shy on good practical experience in actual railroad work. His aunt's husband on his mother's side was a big stockholder, and so such a little thing as lack of experience didn't stand in the way of his selection for the place.

One of his first visits to old man Johnson's division brought him the painful discovery that not an engine on the road was even drilled for an indicator, much less had cards been taken at regular intervals to study the steam distribution. So he turned some of his young college friends loose on the job, and three of the engines were forthwith prepared for an exhibition of what an engine really ought to be. Johnson kept tabs on the cost of the changes, but wisely kept this to himself.

Of course they found the engines all wrong, valves didn't have enough lap, quadrant didn't have notches thick enough to graduate the cut-off to six decimal places, valve wasn't of the best type, and the cards looked like any-

thing but a Corliss indicator diagram. Too much oil was being used according to the best practice of the Great Air Line and, in fact, pretty much everything seemed to be going straight to the bad. After they had the engines down fine they prepared for the great tests with seventeen students to check every exhaust, watch for signs of smoke, count the shovels full of coal to the mile, and measure out the oil with an eye dropper. Then came the report. And that wasn't all, either, for the Super (most forgot to say his name was Smart) had been gathering in a good sized bundle of reports from all over the country on the results obtained from modern roads where men were not tied down to old traditions, etc., etc.

Then came the day of reckoning, and Johnson called it in the solar plexus. Smart called him into a directors' meeting and proceeded to show them the reasons for their road not being a through trunk line and the way to get into that enviable condition.

"Mr. Johnson, we are trying to discover the weak points in the motive power department, and, as you know, have had a few tests made from some of our engines to determine the reasons for the lack of economy in fuel consumption, in oil and in other things. I also have here other tests, from other roads, show-

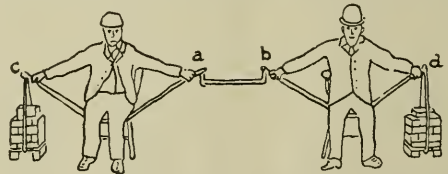

FIG. 4. LIVING MODEL OF THE FORTH BRIDGE.

ing a much greater economy than we are showing, as well as one from the Jigger Valve Gear and the Back Action Valve which you refused to try. I trust that you will be able to explain your position in the face of these facts, as we are very anxious to retain all our old men if they will assist in bringing about a new order of things that make for the betterment of the road."

"Now here are the tests from engines numbers 16 and 20, after changing so as to make a proper card, and compared with the same engines before the change. They are now hauling 23 cars up the hill against 20 before the change, and burning less fuel by five and three-eighths per cent. Can you explain that, Mr. Johnson?"

Then it was Johnson's inning.

"Perhaps not to your satisfaction, Mr. Smart, but the gentlemen here may see a streak of light in a few remarks I feel called upon to make. You forgot to tell them that engines 16 and 20 were ready for the back shop when you came

here; tires in bad shape, cylinders wanting boring, valves needed facing and a few other things. Then they only pulled 20 cars up the hill. You overhauled them, drilled 'em for indicators and let your friends play with 'em for a month, keeping them out of regular service most of the time, monkeying with the valves and

a half per cent. that it squeezed out of a crippled engine.

"Then there's the anti-friction back action valve. Fine thing for the maker, and looks as though it ought to work out all right, but it don't. Our neighbors on the Q. T. & X. have some of them and they are lucky if they run three

for the occasion are of no earthly use to the directors of this or any other road. All of these roads that Mr. Smart has cited are paying more than we are for the hauling of their freight. Their annual reports show this. Some of them are paying as high as three thousand dollars an engine more than we pay for the same capacity for the sake of a few frills and trimming that will make pretty indicator cards, but it's been my experience that indicator cards don't pull trains over the road for a cent. I don't care what the cards from my engine look like, or whether they will even make a card if they are hauling coal over the road at less cost than the other fellow is doing it. They can use double the oil, use more coal if necessary, but what interests me is the total cost of getting that train over the road. This means cost of repairs, number of hours' delay and getting there on time, as well as coal and oil.

"Reports that show what is actually being done month after month in regular service, under exactly the same conditions as the other engines are worth looking over, nothing else is. It's a waste of time. Tests made with everything keyed up to concert pitch are not fair to any one concerned, often get good men into trouble and cost money that might better be thrown away. Mr. Smart didn't tell you the cost of all his

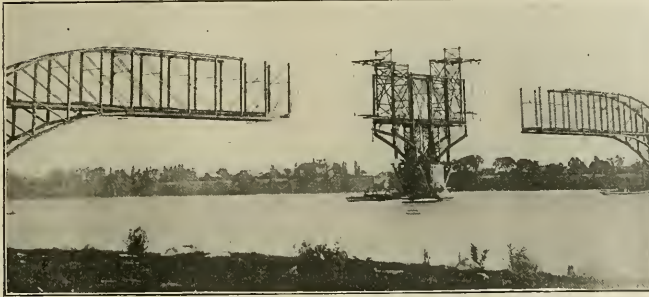

BRIDGE OVER ST. LAWRENCE RIVER AT MONTREAL, SHOWING CANTILEVER METHOD OF CONSTRUCTION.

valve gear so as to make a pretty card. But you don't compare them with the 25 and 26 of the same class in good condition. They are pulling 25 cars up the hill every day, burning less coal and using less oil than either of your engines, and they haven't had a cent spent on them for schoolboys to play with.

"We are hauling more tons of coal and at a lower cost than your Trunk Line friends in spite of their reports. I've seen these and I've also been over their road on their pet engines and know the coal that is being put on the tanks every day. When you want to know about the coal that is being burned, don't stay in the office and ask for reports but go and see what the coal man is putting on the tanks.

"Perhaps they are using a little less oil. That accounts for their engine failures from hot boxes and their large force in the shop to keep the engines moving at all. The oil cranks count the last drop with slide rule and forget all about the repair shop and the hot boxes. If I was running this road just my way I'd double the oil allowance this minute, and I'm dead sure 'twould save money. Wouldn't make a man use it all unless he wanted to, but he'd know if he needed it that there wouldn't be any hanging match when he got back.

"That Jigger Valve Gear test is like the rest of the bunch you've picked out. I happen to know how that test was made. They took the worst engine on the division to run it against, choked her down with a small nozzle so she couldn't hardly breathe and then called it a test. After the show was over they put her into kinder decent shape and she beat the Jigger all hollow, but your report only shows the measly seven and

days without facing. Sounds like a fairy story, and I wouldn't dare say this if I hadn't been over there and seen them doing it. Got the facts from the foreman. Sometimes get more facts there than you do of the master mechanic or even higher up.

"If you want my job for some of your



CANTILEVER BRIDGE OVER THE FIRTH OF FORTH FROM THE TOWN OF LEITH, SCOTLAND.

notebook fiends with the indicator bug in their heads, it's yours any time, but if the gentlemen here want dividends, that's another matter. Reports are fine things when they tell the whole truth, and that's what mighty few of them ever do. Don't intend to deceive in all cases, but there's mighty few of them that don't wander over the line of naked truth, unintentionally. Reports made with everything doctored up especially

monkeying on engines 16 and 20; couldn't if he would, because he don't know of the delays to traffic while his schoolboys were playing horse with it, and it will take several dollars to put them back in as good condition as the other engines of their class.

"Gentlemen, I am at your service."  
"What shall we do with these reports?" asked the chairman.

"Chuck 'em in the fire." responded a

director who was also a heavy stockholder, and that is how Johnson didn't get fired.

#### New Wagon Stock on British Railways.

BY A. R. BELL.

The development of the bogie freight wagon on British railways has been

and the bogie centers are placed 26 ft. 6 ins. apart. The body underframe and bogies are all of mild steel, the bogies being of the American diamond frame pattern. There is a brake block provided for each wheel.

The North-Eastern Railway has recently constructed a number of thirty ton

rollers 2 ft.  $\frac{3}{4}$  ins. in diameter mounted on each of the  $\frac{5}{2}$  in. journals, so that they complete one revolution to five of the axle. Each pair of rollers has a spindle  $\frac{3}{2}$  ins. diameter to which the load is transmitted by a brass lined cap from which the laminated bearing spring is suspended. The speed of the frictional surface of this spindle is thus a little more than one-eighth of that of the main journal and the static friction reduced to a corresponding degree. The general design of these wagons may be followed from the illustration.

The Midland Railway, having the largest coal carrying traffic of any English railway, have given special attention to wagon design and construction. Although they have experimented with large capacity bogie wagons, the latest example is of the 4 wheel type, but of 15 tons capacity instead of the standard 10 tons. It is built entirely of steel, the length inside being 17 ft. 6 ins.; width, 7 ft. 9 ins., and height 4 ft. 6 ins. The sole bars and headstocks are of channel section 10 ins. deep by  $\frac{3}{4}$  ins. by  $\frac{3}{8}$  in.

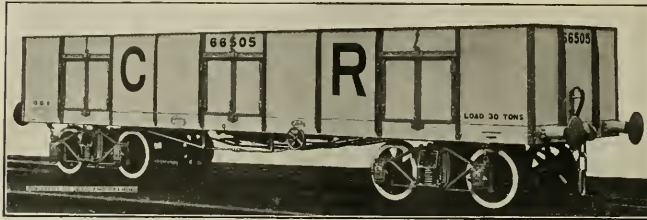

STEEL SIDE DOOR GONDOLA ON THE CALEDONIAN RAILWAY.

somewhat slow as compared with that of the locomotive and passenger rolling stock. There are reasons for this, however, the principle being that a large percentage of the coal wagons belong to private owners, mostly colliery proprietors. An important consideration for them is the handling of the wagons at the loading and tipping stations, where specially designed plants suitable for dealing with wagons of a certain size and capacity have been laid down. Alteration or reconstruction of these plants to take larger wagons would, in many cases, need a large outlay of capital.

Wagons of the American pattern, built of steel, running on bogies and fitted with continuous brakes, have recently been built for many of the large mineral carrying lines, but mostly for their own service. One of the first illustrations shows a bogie wagon for the Caledonian Railway, built entirely of steel. The capacity is for 30 tons of coal, the inside dimensions being 34 ft. 11 $\frac{1}{2}$  ins. long, 7 ft. 11 $\frac{1}{2}$  ins. wide and 4 ft. 4 ins. deep. In addition to hand brakes, operated from either side, these wagons are fitted with the Westinghouse air brake.

ironstone wagons of a novel type. They are carried on four wheels and are of the hopper type. The length of these vehicles over headstocks is 20 ft. and extreme width, 8 ft., the height of the top



FOUR WHEEL HOPPER CAR, NORTHEASTERN RAILWAY.

of the sides above rail level being 9 ft. 10 ins. The side and end plates are  $\frac{1}{4}$  in. thick supported by stiffeners of T-section. The wheels and axles are of larger dimensions than usual, the diam-

eters of the sides above rail level being 9 ft. 10 ins. The wheels are of the standard diameter, 3 ft. 2 ins., and have a wheel base of 10 ft. The weight empty is 7 tons 3 cwt.

#### Resilient Wheels.

Resilient driving wheels were used to a considerable extent on locomotives in the United States before the durable Bessemer steel rail was introduced, and they did very good service in softening the blows on the fragile iron rail. It looks as if the freight automobile was a good subject for an invention of this kind, but the few trials made with resilient wheels have not been encouraging.

Reports from France on the contest for resilient, or spring wheels, shod with solid tires, are to the effect that the results were disappointing. The wheels competing were designed to do away with the use of pneumatic tires on commercial motor vehicles, but their showing appears to be a substantial vindication of the pneumatic. The test extended over eight days, the course being



HOPPER COKE WAGON ON THE CALEDONIAN RAILWAY.

Another type of wagon for the Caledonian Railway is of the hopper type, having a capacity for 40 tons of coke or coal. The length of this body, inside at top, is 34 ft. 11 $\frac{1}{2}$  ins.; width, 7 ft. 11 $\frac{1}{2}$  ins., the length over buffers being 38 ft. The diameter of the wheels is 2 ft. 9 ins.,

eter of the axles being 6 $\frac{1}{4}$  at the center, increasing to 7 $\frac{1}{2}$  ins. at the back. The wheel centers are of cast steel with eight oval spokes and are fitted with 3 in. tires having a tread 5 $\frac{1}{4}$  ins. wide. The journals are fitted with a patent anti-friction roller consisting of two cast steel

from Paris to Nice and return, 1,338 miles. Of the ten cars that started, only three finished. The Soleil, Edmund Levy and Garchey devices were the three to finish. According to the rules of the competition, no award was to be made if an average speed of 18.6 miles per hour for the entire trial—1,338 miles—was passed. The three cars which finished went faster than the average; the car with the Soleil wheels averaging 19.1 miles an hour; the car with the Edmund Levy wheels, 23.3 miles an hour and the one with the Garchey wheels 25.3 miles an hour.

#### Heavy 2-8-0 for Cuba.

The Western Railway of Havana have recently purchased from the Rogers Locomotive Works, at Paterson, N. J., two consolidation engines, which are said to be the heaviest freight engines on that road. The line extends

driving box equalizers terminate each in a set of coil springs. The main rods is of I-section while the side rods are solid bars.

The boiler is of the extension wagon top variety, 60 $\frac{1}{8}$  ins. diameter at the smoke box end, the gusset sheet increasing the diameter of the shell to 68 ins. The fire box is narrow in the sense that it does not extend beyond the frames, but is about flush with the outside of the frame bars. It measures 10 $\frac{1}{2}$  ins. long by 42 $\frac{3}{4}$  ins. wide and thus gives a grate area of a little over 31 sq. ft. The total heating surface is 1,617 sq. ft. and the ratio of grate area to heating surface is as 1 is to 52. The fire box gives 140 sq. ft. of heating surface. The tubes are 202 in number, 2 $\frac{1}{4}$  ins. in diameter, and the heating surface which they give amounts to 1,477 sq. ft.

The weight of the engine itself is 136,000 lbs., the engine truck carries 15,500

few of the principal dimensions are as follows:

Axles—Driving journals, main, 8x9 ins.; engine truck journals, 5 $\frac{1}{2}$ x9 ins.; tender journals, 5x9 ins.  
 Boiler—Material, flange steel; thickness, ring, 1st, 9/16 in.; 2d, 3/8 in.; 3d, 3/8 in.; throat, 11/16 in.; dome, 1/2 in.; front tube, 1/2 in.; roof, 1/2 in.; side, 1/2 in.; back head, 3/8 in.  
 Fire Box—Material, fire box steel; depth, front, 62 $\frac{1}{2}$  ins.; back, 60 $\frac{1}{2}$  ins.; thickness, crown, 3/8 in.; tube, 1/2 in.; side, 3/8 in.; back, 3/8 in.; water space, front, 4 ins.; side, 3 ins.; back, 3 ins.  
 Seams—Horizontal sextuple circumferential double riveted.  
 Stay Bolt—Material, Falls Hollow, 1 in. diam.  
 Crown Stays—Material, Fall's Hollow, 1 in. diam.  
 Tube—Iron, No. 13; B. W. G.  
 Crank Pin—Size, main, 6x6 ins.; main side, 6 $\frac{1}{2}$ x5 $\frac{1}{2}$  ins.; intermediate, 5 $\frac{1}{2}$ x5 $\frac{1}{2}$  ins.; front, 4 $\frac{1}{2}$ x3 $\frac{1}{2}$  ins.; back, 4 $\frac{1}{2}$ x3 $\frac{1}{2}$  ins.  
 Cylinder—Steam ports, 1 $\frac{1}{2}$ x18 ins.; exhaust, 3x18 ins.; bridge, 1 $\frac{1}{2}$  ins.  
 Fire Brick—Supported on studs.  
 Piston—Packing, 3/4 in. square cast iron rings.  
 Tender—Weight empty, 41,700 lbs.  
 Valves—Travel, 5/8 ins.; steam lap, 1 $\frac{1}{2}$  ins.; exhaust, line and line; lead in full gear, 3/16 in. constant.  
 Eames vacuum brake.  
 Rush on throttle valve.

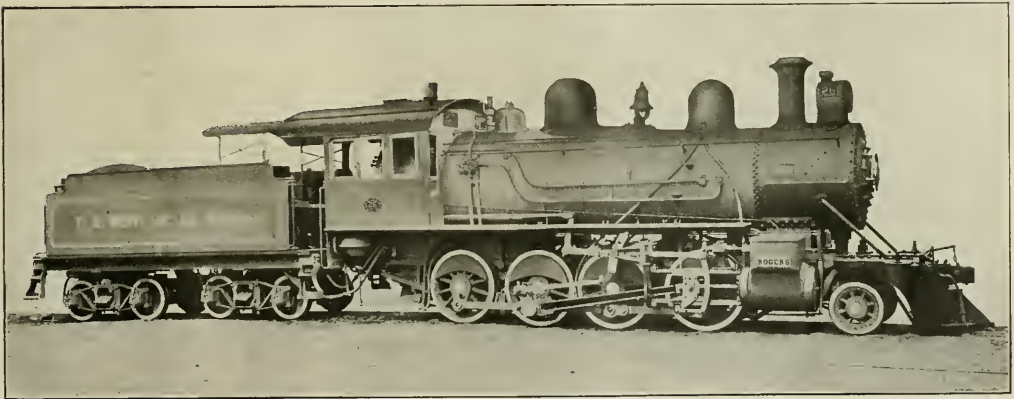

CONSOLIDATION ENGINE FOR THE WESTERN RAILWAY OF HAVANA.

C. C. Vernet, Locomotive Superintendent.

American Locomotive Company, Builders.

to the west end of the island into the Pinar del Rio district, and is one of the important railways of Cuba.

The engines are simple and have cylinders 20x24 ins., with 50 in. driving wheels. With 180 lbs. boiler pressure these engines develop tractive effort of 29,376 lbs. The weight on the drivers is 120,000 lbs., and this gives a ratio of adhesion of 4.1, or, in other words, the engine can exert a drawbar pull of one-quarter the weight resting on its driving wheels. The valves are Morse balanced slide actuated by Walschaerts gear. The front and rear drivers only are flanged, and the third pair are the main wheels. The springs for the leading and second drivers are overhung, and these two are equalized together. The main and rear drivers have one semi-elliptical spring between them, placed between the top and bottom frame bars and the outer ends of the

lbs. The tender weighs 97,000 lbs., thus giving a total of 233,000 lbs. for engine and tender. The driving wheel base is 14 ft. long, while that of the whole engine is 21 ft. 4 ins. When the wheel base of the tender is added, the total amounts to 49 ft. 4 $\frac{1}{2}$  ins.

The tender has a sloping top tank, as indicated by the line of rivets shown in our illustration, and on top of it the fuel is carried. The tank holds 4,500 U. S. gallons and the fuel load is 9 tons. The tender is equipped with a sort of weather roof, or, more properly, a sun shade, or, as it might be called a steel umbrella, which, though it does not confine the heat from the boiler head, yet prevents the direct rays of a tropical sun from reaching the occupants of the cab. The tender frame is made of 10 in. channel bars, and the whole is mounted on diamond arch bar trucks. A

#### Exploding Boilers for Knowledge Sake.

A series of experiments with boilers was made by the United States Government years ago, that gave very valuable data about boiler explosions. One of the experiments was with flat-stayed surfaces that would very well represent side sheets or crown sheets secured by stay bolts. Heat was applied with plenty of water over the heating surface until the vessel exploded from over pressure. Dr. Coleman Sellers, who was present, describing this explosion, wrote: "It was fired up, and when the steam reached 125 lbs. we left the boiler and retired to a safe place. In about five minutes, with about 180 lbs. gauge pressure, it exploded. The sheets went out in the form of dishes, each part where the stay bolt was presenting an indentation like a mattress. Every stay bolt was drawn out of its hole. No stay bolt was injured in the slightest degree

on its thread, but every hole, from which a stay bolt was drawn, was enlarged sufficiently to allow the stay bolt and its head to come out."

This is information worthy of consideration by people who act as experts before the courts when boiler explosions happen. The writer was present at a law suit once over an exploded boiler, and the attempt was made to prove that the accident was caused by low water. We heard several so-called experts testify that the sheets must have been hot because the stay bolts were pulled through the sheets without tearing off the threads.

#### LOW WATER SELDOM CAUSES EXPLOSIONS.

The belief exists among many people that a boiler will not explode so long as it contains a good supply of water. Properly conducted experiments have



N. Y. C. 440 READY FOR THE ROAD.

repeatedly disproved the correctness of this theory. An easily made experiment is: Take a piece of steam pipe 3 ins. diameter and 3 ft. long. Screw a steam tight cap on one end and put water in the pipe till it is two-thirds full. Then drive a pitch-pine plug into the other end until it is within 3 ins. of the water giving room for expansion. Put the pipe on a bright fire and get out of the way, for an explosion will follow in a few minutes. If all the water was converted into steam there would be no violent explosion. The violence of a boiler explosion is directly in proportion to the amount of water ready to flash into steam when a rupture is made great enough to suddenly release the pressure.

#### INJECTING WATER UPON HOT SHEETS.

Another unfounded belief about steam boilers is that injecting feed water upon heated plates is likely to cause an explosion. Iron and steel boiler plates do

not act that way, although a hot cast iron plate might crack when quenched with water. If a piece of iron or mild steel is made red hot and quenched in the coldest water it will be annealed instead of cracked. For this reason there should be no hesitation in putting on the feed when the water in a boiler is found to be low. The most harm that can be done will be that the sudden shrinkage of the sheets will cause the seams to leak.

The Pennsylvania Railroad Company, years ago, carried out a series of experiments with locomotive boilers that prove most of the statements made. A locomotive which was condemned to be scrapped, was run out on a side track in the woods near Altoona, and experiments made upon it. The plan was to fill the boiler with water, raise a high pressure of steam, then run off the water until the crown sheet was exposed, permit it to become red hot and then pump cold water into it, to find out the effects. In the first experiment the boiler exploded before they had time to blow off any of the water. They then took another old engine whose boiler stood the steam of unusually high pressure. After steam was raised the water was drawn off until it was below the crown sheet. They waited long enough for the crown sheet and the upper part of the fire box to become red hot, then they forced a supply of water into the boiler by means of a

powerful fire engine, and nothing happened except that the seams leaked and the steam went down. This was repeated several times, always with the same result. The boiler was damaged by the overheating, but no accident happened.

#### Sir James Thompson.

Much regret is expressed at the death of Sir James Thompson, late Chairman of the Caledonian Railway, and one of the most prominent figures in the British railway world. He was connected with the company for fifty-two years, and it was largely through his marked executive ability that the railway shows such a record of splendid achievement. In 1897, Queen Victoria conferred on him the rank and title of Knighthood. In 1906, he was appointed Deputy-Lieutenant of Lanarkshire, the county in which the city of Glasgow is situated. Sir James was a general favorite wher-

ever he went, and was of a social and jovial disposition, and was a clever story teller. He was always extremely kindly to the employes of the road. When he began his industrial career the road was a local line of 157 miles in length. There is now 1,251 miles of railway in the Caledonian.

In order to better serve the needs of a greatly increased Western business in their steam, water and gas fitters' tools and machines, the Armstrong Manufacturing Company, of Bridgeport, Conn., have lately opened a branch office and warerooms at 23 South Canal Street, Chicago, Ill. The new branch is in charge of Mr. Hugh S. Laing, formerly assistant manager of the New York City branch. The premises include an office and show room, 18 ft. wide by 150 ft. deep, and a large basement for storage. In addition to a complete line of the genuine Armstrong Stocks and Dies, there is a full stock of Armstrong's Pipe Cutters, Pipe Vises, Bard Adjustable Bushings, Ratchet Attachments for Die Stocks and Pipe Wrenches. In the salesroom a full line of pipe cutting and threading machines taking up to 6 in. pipe are on exhibition. Buyers of pipe-fitters' tools and others in the West or central part of the country should communicate with the Chicago office for any particulars concerning the Armstrong tools.

#### Lead Pencils.

Lead pencils have no lead in them. The heart of a pencil is graphite, sometimes called plumbago. Such pencils have been in use over three centuries, but began to become popular about a hundred years ago. Henry D. Thoreau, of Concord, a literary man of recognized ability, made pencils, but he lacked enterprise. The firm of Faber, Nuremberg, Germany, was the first to establish a great pencil factory. Several firms flourished in England, the great Barrowdale mine furnishing a superior quality of graphite.

The Dixon Crucible Company of Jersey City, N. J., began making pencils in 1872, and immediately came into popular favor. To-day the Dixon Graphite Mines at Ticonderoga, New York, produce about 130 tons of rock and graphite every working day. The finished graphite is mixed with clay, the more clay the harder the pencil. The soft pencils are made larger than the hard ones, in order to obtain the necessary cohesive strength. The mixture of graphite and clay is baked in a kiln at a temperature of 2,200 deg. Fahrenheit. After the strips are taken from the kiln they are ready to be placed in the Florida cedar, which is the wood used.

# General Correspondence.

## Derailment of Ten-Wheel Engines.

Editor:

I have read with great interest the article on the editorial page of your June number, entitled "Ten Wheelers May Be Dangerous," and I believe that the relation between the gauge and the flanges for wheel bases of different length will be found to be a more fruitful source for investigation as to probable cause of derailment of 10-wheel engines than an inquiry into the least minimum weight which can be safely put on the engine truck of a 10-wheel engine.

It may in general be taken for granted that a locomotive engine truck, and, in fact, all the wheels of the locomotives will of themselves follow the line of least resistance, and, furthermore, that the tendency of a body to move in a straight line will apply as well in locomotive practice as in our philosophy. If the momentum of the locomotive carries it over the outer rail, it may safely be concluded that either the elevation is not sufficient for the speed at which the engine is running—and it may be impracticable to give the necessary elevation to some curves—or that some other cause exists on account of which the engine is unable to follow the line of least resistance. It is a source of wonderment to many people that the small and practically insignificant flanges on wheels will guide a locomotive safely around a curve, but the explanation is that the engine is simply following out the law of natural philosophy, which is following the line of least resistance. It is much easier for a pair of wheels to roll around a curve on a rolling friction of possibly five or six pounds per ton than to either slide over or raise the flange bodily over the ball of the rail. The sliding friction might possibly be one-fourth to one-fifth of the weight on the wheel representing the sliding co-efficient of friction of metal on metal, whereas the lifting force required to raise the flange bodily over would be a pound of force for every pound raised. We think from this that it can be seen that under ordinary conditions any engine will follow the track and where it does not follow the line of least resistance some obstacle exists to prevent such a line being followed.

The writer some years ago had occasion to spend considerable time in the investigation of derailments of 10-wheel engines, and during much of this period the attempt to solve this problem seemed to be absolutely without result, as at times the derailments

would cease as though by magic and reappear after an interval of some time. It may be well to state at the outset that it was finally determined that it was the relation of the wheels to the track on which the engines were running which caused the trouble and there was no defect existing in the wheels—if defect it would be considered—which could not have been corrected in the track, or defect in the track in its relation to the wheels which could not have been corrected by properly gauging the wheels. I know of no shorter way of explaining the matter than by a simple citation of the facts in the case as proven.

sence of weight on the truck was causing the difficulty. Twenty-three hundred pounds, or thereabouts, of metal was placed on the front end of these engines back of the bumper beam, and by the time the engines were fully equipped the derailments had practically disappeared, and the mechanical department was given the credit of having remedied a defect in these engines by the application of the weight, which has been suggested as a remedy in your editorial.

During the time that the engines on the Kansas City, Ft. Scott & Memphis were being derailed the engines were running on the K. C., M. & B. on much sharper curves and that class of engines



THE "FLYING YANKEE" ON THE MAINE CENTRAL.

About the year 1887 the Kansas City, Ft. Scott & Memphis purchased a number of 10-wheel engines and the K. C., M. & B. and associated lines purchased a number of exactly the same build. The engines practically gave trouble from the start on the Kansas. Ft. Scott & Memphis on track which would be designated as crooked, and these derailments occurred so frequently that they compelled the discontinuing of the use of these engines on certain sections of the line—generally branches. The derailments were practically all confined on the main line to a certain district of not over 20 miles in extent where curves were numerous and rather sharp. After a conference with the general superintendent it was decided as being a possible preventive to put weight on the engine truck, as it was thought that 22,000 lbs. was too light, and that the ab-

made, as I recollect, in the neighborhood of one and one-half million miles without derailment, and our records will show that those officials on the K. C., M. & B. familiar with the service of the engines stated positively that there was nothing the matter with the engines and that there must be some peculiarity in the track on the K. C., Ft. S. & M., as the engines were being operated on much sharper curves and under much more trying circumstances on the K. C., M. & B. On the derailments ceasing the investigation on that line as to probable cause was dropped. It may be well to state here that practically every superintendent of motive power in the country was consulted during the investigation as to the probable cause, and many explanations were given as to the possible cause. However, the transportation people were of the opinion that the

ultimate cause had been lack of weight in the engine truck and the matter rested in that way for a number of years.

About 1898, six or eight years after the trouble had ceased on the K. C., Ft. S. & M. this trouble appeared on the K. C., M. & B. on engines that had previously run for over ten years without derailment and most of these derailments were quite serious, involving the loss of a number of lives. We were requested by the president to make a thorough investigation as to the probable cause and to consult anyone who could probably give us an explanation of this trouble. I may say here that the heads of the transportation department had changed during the time between the periods of derailment, consequently the new officials were not fully conversant with the former episode. An investigation of the facts de-



HERE SHE COMES!

veloped that in four prominent cases of derailment no one of the engines had been out of the shop over two or three months. Three of the cases, as I recollect, the engines had not been out to exceed 30 days. The mechanical department took the stand that the engines were being turned out exactly as formerly, and that as we were using the same gauges and same practice of mounting wheels that we had used for ten years there could be no ground for supposing that any change in the engine practice had caused the derailments, and were of the opinion that some change had probably been made in widening the gauge at curves. Most of the derailments in question took place on 8 or 9 degree curves. After an investigation it was found that the practice of widening the gauge on curves began at a date not exceeding three months previous to the time of

the beginning of derailments on the K. C., M. & B. and that the advent of the new practice when accompanied by laying of new rails was the probable cause of the derailment.

At that time there had been a number of articles in the papers advocating confining the widening of the gauge on curves to a minimum which possibly influenced those in charge of the track. It was found that three out of four cases of derailment occurred where the new rail had been put in. The fourth case was for some time a poser, as it occurred on worn rail, but later on it developed that the old rail had been moved in accordance to the new practice of widening, and was probably the cause of that derailment. The facts which we deem as conclusive as determining the final cause of derailments in question were these: The transportation department were going on the supposition that 15 ft. would represent the longest rigid base on any 10-wheeler on the line and were widening their gauge on this basis. As a matter of fact, all of the 10-wheelers were with rigid truck with the plain tire ahead, consequently the driving wheel base of the engine was not the rigid base of the engine, as the forward driver being plain had no influence as to confining the motion of the engine. The actual rigid base of these engines was the distance from the center of the engine truck to the center of the back pair of drivers, and instead of being 13 ft. 1 in. on this particular class of engines, was in the neighborhood of 18 ft. It was found by actual measurement that taking the distance from back to back of flanges as 53¼ ins., which was our practice at that time, plus two flanges, 1½ ins. maximum, it represented 56¼ ins., or leaving a lateral motion of practically ¾ in. in the 4 ft. 8½ ins., and it was found by actually gauging the track at points where derailments occurred that the engine having an 18 ft. base would not allow all of its flanges to go down inside of the gauge by ½ in. An engine with an 18 ft. rigid base, following the practice above given allowing ¾ in. lateral, would safely pass around a curve of about 3½ degrees radius. Any curve sharper than that would require widening. If tire were turned so that the flanges were 1¾ ins. thick, an engine with the same base would go around a curve of 6 degrees without widening. It was found that the new practice of widening on all sharp curves would not allow the flanges of the engine to go down fully without springing the rail, consequently at certain rates of speed the engine truck wheel would mount the rail and cross over, generally leaving a mark of 4 to 6 ft. long on the ball of the rail. The engines apparently did not go off every time because the momen-

tum was not sufficient and even a small portion of the flange below the ball of the rail was sufficient to hold it, but under the right momentum the engines very frequently left the track.

These derailments disappeared either when the rail became worn or when the tire became worn sufficiently to allow sufficient lateral motion. It struck me that it was quite conclusive that weight had nothing to do with these derailments, because the engines were just out of the shop, the rail was new and a process of widening followed which was not sufficient for the length of wheel base. I believe strongly that where these unexpected derailments occur it is worth considering not how much weight the engine truck carries, but is the widening of the gauge sufficient for the actual wheel base of the engine, and have any items such as newly laid rail or change of practice in widening gauge entered into the proposition. It is possible that a good many engines are running to-day on curves which are somewhat worn which would be derailed if the curves were relaid on the present practice and engines happen to be newly out of the shop and tire turned about the dimensions given. I believe that it is a simpler explanation to say that there is a binding somewhere so that the truck cannot pass around the curve, rather than to surround the matter with mystery of improper weighting and mysterious liftings by which the engine finally mounts. I have seen how tenaciously even engines with very light weight on the trucks will cling to very poor track, and I cannot feel otherwise than that if you give the engine truck a chance to go around the curve, it will certainly go, and in my judgment, a 10-wheel engine is as safe as any other.

W. A. NETTLETON,

Gen'l S. M. P. of the St. Louis & San Francisco.

St. Louis, Mo.

### Creeping of Rails.

Editor:

It is well known by everybody in charge of the supervision of railroad tracks and perhaps by some observing engine crews, too, especially on double track lines, that the rails don't remain in the position in which they have been fixed when the track was laid. So it may be known, too, at least by close observers, when and where this movement, or "creeping" takes place, in what direction it is. The power by which these rails get shifted and the reason for this occurrence may be unknown by many people who are not directly engaged with maintaining and repairing tracks, especially on level ground railways.

Having been driving for a long while, "with the hand on the throttle," on a double-track mountain railway (Gothard



Railway in Switzerland), I had plenty of opportunity to study the effects caused by the creeping of rails, especially when running up hill with slow goods trains. The rails always get moved in the direction the trains are running over them.

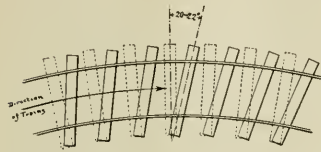

FIG. 2. TIES SHIFTED ON CURVE.

When the track is straight, both rails advance nearly with the same power and one as much as the other is causing sometimes a sidewise remove of the whole track, in curves the outer rail gets shifted with more power and advances much more than the inner one, often causing considerable narrowing of gauge. The angle between the new position the sleepers have been forced into by creeping of the rails and the former one, sometimes amounts to about 20 to 22 degs., as in Fig. 2. The

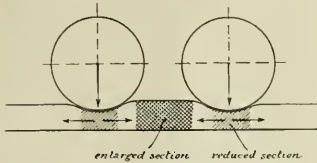

FIG. 3. LOADED WHEELS ON RAIL.

force under which that advancing takes place may be shown by the sketches.

Fig. 1 shows one of the rail connections still most generally used on mountain railways. Four spikes on each side of the rails should prevent any kind of horizontal moving, pressing their heads against the fishplate, but as we see, the heads of the spikes, as sketch shows, have been bent over. Sometimes the fishplates crack out, A-A, Fig. 1, or if

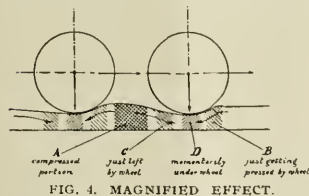

FIG. 4. MAGNIFIED EFFECT.

the spikes and fishplates are too resistant, the sleepers get moved, heaping up the ballast before them, and the track loses its standard direction.

Now to explain why these rails get moved so powerfully and why on curves the outer rail advances so much more than the inner one. On a grade of 1 in 50 the track itself tends to slip downhill with the force of 1/50 of its weight; be-

sides that, on all trains the brakes are strongly applied, thus causing another component of 1/8 to 1/5 of its weight, especially when trains get stopped roughly. These two components seem to be enough for giving rather a good explanation for the case, though between rail and wooden sleeper the coefficient of friction is about 0.65 to 0.26 (0.05 only when both, rail and sleeper, are perfectly immovable, but when the trains are rolling over them, they vibrate, reducing the coefficient of friction from 0.65 to 0.26).

What is the matter, when we investigate the track of the uphill running trains? Will the rails there get moved in the downward direction, as might be expected from the action of the driving wheels of engine? Not at all; with the same mysterious force they advance in the uphill direction! We will see there bent spikes, cracked fishplates, shifted sleepers, as well as on the other track;

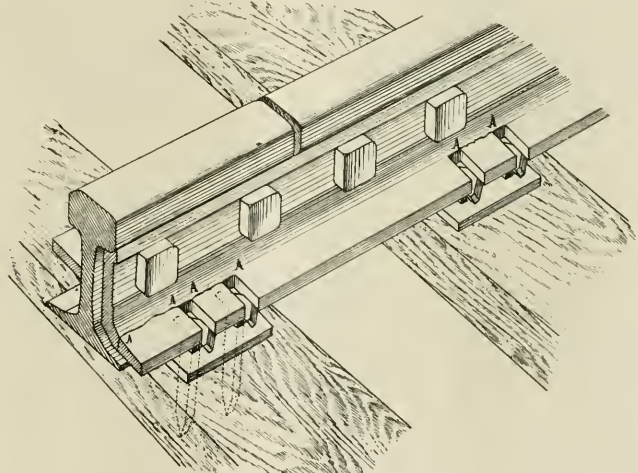

FIG. 1. RAIL JOINT WITH BENT SPIKES.

and now, how to explain that: After having taken in consideration all forces, components, influence of differences in temperature, I came to the following conclusion:

Let us imagine two loaded wheels on one rail (Fig. 3). In what way will the rail get deformed by the pressure exerted by the wheels? Under them the rail section gets reduced, microscopically, of course, and between them the rails become enlarged. To clearly picture in the mind these effects, one may imagine the rails to be made of india rubber, because not only laterally the material between wheel and sleeper gives way, but as well in a longitudinal direction, thus producing a pressure of the material between the two wheels, and consequently something like upsetting.

Let us investigate further the effects caused when the wheels begin to move

over the rail. (See Fig. 4.) Before and under the wheel the rail gets pressed, behind it the material tends to recover its former shape and volume, as soon as the wheel has passed over. The portion (B) before the section momentarily under the wheel (D), compressed, under front wheel (A), the portion just left by the first wheel (C) will recover its loss of volume partly from the compressed portion before the first wheel (B), and partly from the portion before the following wheel (A). Consequently a microscopical transportation of material from before the first wheel as well as from before the following one to the just left portion behind the first wheel must be the result. Considering now that steel as well as all solid materials cannot recover its former shape instantaneously ("elastic after effect"), the portion just left by the wheel has more time to get material from the pressed

portion of the rail between the wheels than from the portion before the first wheel; therefore, the rail always tends to lengthen in the direction the wheel rolls over it.

This view of the case may seem to be too theoretical, but when considering the coefficient of elasticity of steel,\* one may imagine that the effects are of the microscopical kind, and only become visible when added together by numerous wheels rolling over the rails all in the same direction. The more strongly the rails get pressed, for instance, outer rail in curves the more they get shifted.

WILHELM WÜSCHER,  
Ingeniero Mecanico, Rosario,  
Argentina.

[\*The modulus of elasticity of steel, as given in Kent's Mechanical Engineers' Pocket-Book, is about 30,000,000 lbs.—Ed.]

### Gasoline Rivet Forge.

Editor:

Enclosed is a tracing of our gasoline rivet forge and atomizer, together with burners for heating frames and for laying up corners of flue sheets, etc. As we consider the improvement of boiler repair practice of even more importance than increasing machine output, I am sending you this sketch. This apparatus is very cheaply made and gives the best results. With this forge rivets can be heated to a cherry red in three minutes and 40 or 50 of them can be thrown on at one time, and can be heated as fast as two gangs can drive with pneumatic hammers. As it is impossible to get them hotter than bright cherry, they cannot be burnt.

It takes about three gallons of gasoline per day to run this. If a lower grade than 87° test is used the tank will have to be heated with steam coil around

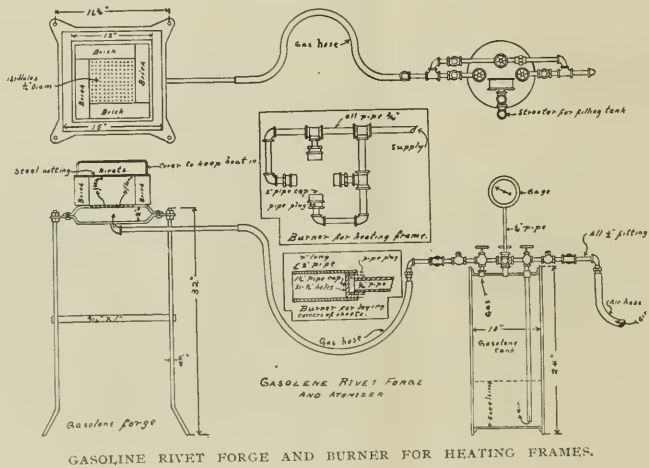

GASOLINE RIVET FORGE AND BURNER FOR HEATING FRAMES.

it. The screen, where the rivets lay on, will burn out, where forge is run steadily, in about three hours, but, as it is only scrap netting, the cost is practically nil.

The single burner shown is for setting up corners of flue sheets, etc., and can be used in connection with same tank. The burner for heating frames is very useful for straightening frames, etc. The burners must not be more than  $\frac{1}{2}$  in. away from frame else the atmospheric pressure will cut the flame and prevent it from burning. These are not patented and anyone is welcome to make use of the idea.

V. T. KROPIDLOWSKI,

Winona, Minn.

C. & N. W. Ry.

### Electric Headlights.

Editor:

Much has been said lately relative to comparative cost of maintaining an elec-

tric and oil headlight. The first cost, as has been said, is the big item that seems to scare the railroad company. The superiority of an electric headlight has demonstrated itself in such a way that the cost does not seem so great. When one considers the cost of a wreck on one of our fast trains of to-day, three or four hundred dollars for so valuable a safeguard as an electric headlight seems very small.

The cost of maintaining an electric headlight, as proved by statistics gathered by a prominent railroad company, is much less than the cost of an oil headlight, and when the men who have the care of the electric headlight become better acquainted with the care and operation of it, the troubles will be, as far as would be possible with any machine, eliminated and the cost of repairs reduced to a minimum.

An electric headlight is, as far as

and if new casting have been used in the steam end of the dynamo the governor should be examined, and cleaned out if necessary, before placing the machine in service. To some it may seem unnecessary to test the electric equipment before placing it in service, but I will say this much for the equipment, it is less liable to give trouble after having undergone a general overhauling by a careful workman than any other special appliance on an engine. Taking into consideration the limited time one has after an engine is hot, until it is ordered, it is better to know that the machine is in perfect working order before placing it on the engine. Another point in overhauling is maintaining standards.

Sometimes men in charge of these electric lights imagine by altering standards that they get better results. The Pyle-National Electric Headlight Co., no doubt, have spent a great deal of time and large sums of money in perfecting their equipment and adopted the present form as their standard. So the better plan is to maintain their standard and things will work better all round.

Place the dynamo in such a position that a short steam pipe can be used and locate the steam throttle in a convenient place in cab so engineer can regulate the speed of the dynamo should it become necessary to do so. Exhaust pipe should be as free from sharp bends as possible and not piped into the smoke box. The best location for a dynamo is on top of the boiler in front of the cab. This location permits a short steam pipe, a short exhaust pipe to extend above roof of cab, and short cab wires, but necessitates long main wires, due to the fact that these wires have an extra heavy protection in form of a covering. I do not believe the long wires are a detriment to the light in any way. Running wires through the hand rail and wooden casing in the cab is not good practice, the better way being to arrange everything so that it is easily accessible to the inspector. The electric headlight equipment is so constructed that all common defects are easily traced and repaired without delay.

Inspection of the electric headlight by a competent inspector each trip is a good practice, but not an absolute necessity, and in some cases might encourage the engine crew to neglect their duty and leave everything to the inspector. If the engine men will clean the commutator and brushes each trip with clean waste, clean off the electrode, see that the carbon works freely in its clutch, keep all screws tightened, not use sandpaper too freely on the commutator, and oil the parts necessary, the

knowledge about it is concerned, the same as the air brake, valve motion, etc., the more thorough knowledge a man has of the operation, the less trouble he will experience in tracing, locating and repairing the defect.

If an electric headlight is to be maintained successfully and to the satisfaction of all concerned, a few of the points necessary to consider are as follows:

The mechanic who is to overhaul this machine must have a thorough knowledge both technical and practical, for a man who thoroughly understands what is expected of each part of a machine and its relation to other parts seldom has any trouble in repairing. On the other hand, a man who is lacking in this knowledge is stumbling along in the dark. After repairing the electric headlight equipment it should be tested, governors set, and allowed to run until bearings are in shape for service.

headlight failures will be almost entirely eliminated and cost of repairs reduced to a minimum.

JOHN F. LONG,  
Gang Foreman, Frisco.

Monett, Mo.

**Ancient Cut-off Gear.**

Editor:

Some time ago I wrote you in regard to an independent cut-off gear that came out on some early "Norris" (Richard Norris & Son and Norris Bros.) eight-wheelers. It is possibly fifty years since these engines came to the Phila. & Columbia (Penna. State road), so, of course, these sketches are from memory, and as I saw them in operation in my boyhood days. Their construction was so indelibly photographed on my memory that it takes very little thinking to get the thing together about as it was at that time. If I am wrong in my figures there are few men living who can "say thee nay," and men born since 1850 know nothing about it unless they can produce old drawings to prove me wrong. When the "Venango" and "Tioga" came to the State road, and they being the first "multi-coupled" Norris engines on the road, they were equipped with the valve gear Type A, Norris at that time using what was called "Spanner" hooks on his cut-off gear. A, Fig. 1, shows spanner hook with back end pivoted by strap and brass on pin B in back end of cut-off valve rod, which is supported in the fixed guide K. The position of the hook as shown is such as to have the main and cut-off valves move in unison. When the cut-off valve is in operation the tumbling shaft lever I being thrown

ular with Eastwick and Harrison (see Gowan & Marx) and with Baldwin. The guide bars on Norris and E. & W. engines were round; on Baldwin, a solid cast iron guide with V bearings top and bottom, the pump being incorporated in the guide, although some of the Baldwins had a guide square in section, but with the main rod coupled to outside of crosshead, as shown. In Type B is shown a modified form of valve.

having no flanges. Rods were prevented from turning on the brasses by having slot in brass to take key. All rod bolts had a turned head with pin hole through; the body of all rods turned and polished; in fact, the rods were very nearly an all lathe job. D, Fig. 4, shows main and cut-off valves. The main valve did not uncover the ports at extreme travel as the steam was admitted through the passages FF. These

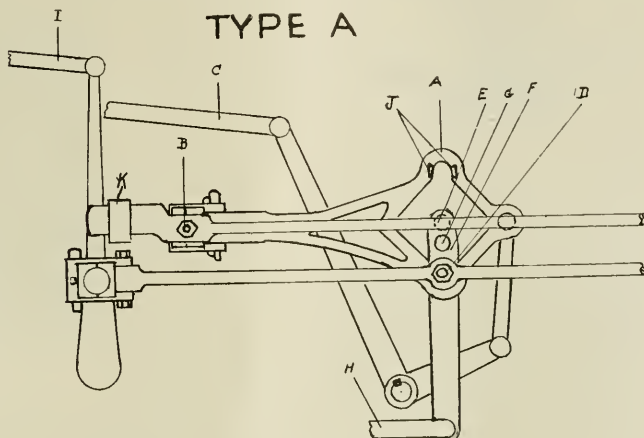

FIG. 1. THE SPANNER HOOK.

a cut-off eccentric and rocker being substituted for the crosshead motion in Type A. The back end of cut-off valve gear with the spanner hook reversed; rod was supported by a guide secured to back end of main valve rod. This gear was on quite a number of engines

engines all came to the road without cabs, so far as I can remember; in fact, I know some of them had no cabs, by having taken a ride on the engines at different times. They were all dome boiler engines (Bury), no steam gauge, bell or cylinder cock rigging, smoke stack of the "Shultz" design, all stacks jointed to admit of lowering while passing covered bridges. And these engines were notoriously smart and good steamers. Fig. 5 shows spring arrangement on "Norris" six-wheel tenders belong-

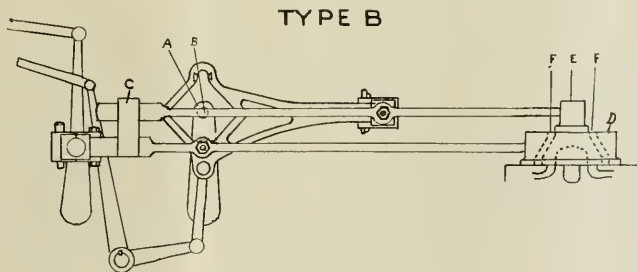
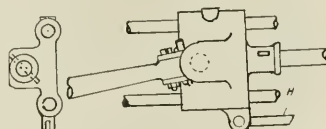

FIG. 4. MODIFIED FORM OF MOTION.

forward, the hook drops down and engages the pin E in top end of motion lever F, and at the same time disengages the pin D in main valve rod. The motion lever is pivoted at G on a stationary bracket, the lower end of lever being connected to the crosshead by the rod H. The type of crosshead used on these engines and two others is shown in Figs. 2 and 3, front end and side views. This crosshead was also pop-

(Norris) that came to the road later. These engines having a different crosshead or of the two bar kind, square in section, these guides were in a horizontal line with the piston, or if we placed a straightedge crosswise on the guides, it would touch both guides and piston. The back end of main rod and both ends of side rods were turned and the strap bored to fit; rod brasses were also turned to fit the straps; the brasses



FIGS. 2 AND 3. CROSSHEAD AND ATTACHMENT.

ing to engines quoted above. Now, brethren, the floor is yours.

W. DE SANNO,  
Veterans' Home, Los Angeles, Cal.

**Valve Setting by Air.**

Editor:

This is a sketch of a valve setting machine, a brief description of which

may interest some of your readers. The original device known as the Farrington valve setting machine, similar to that shown, but without the cylinder and its accompanying parts, *A, C, D, E,*

concerned, but you have overlooked another crop of Europeans that come to America and in some ways are really

of the trade just as they do of the language. Where there is a chance to keep them on ashpans or shaking grates

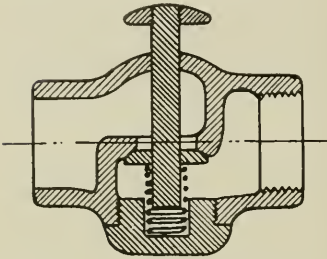

EXHAUST VALVE WITH PUSH BUTTON.

is worked by hand power and requires two or three men besides the valve setter to operate it.

We have at the Marquette, Mich., shops of the Duluth, South Shore & Atlantic, made an improvement on this machine, by utilizing the steam end of scrapped Westinghouse air pump (*A*), which is fitted to shaft (*B*) but allowed to oscillate on it. To the piston rod of this cylinder is fitted a ratchet arm (*C*) provided with a pawl for reversing the motion, this being done by valve setter, by means of reverse motion rod (*D*).

The machine is worked by air, and by means of an exhaust valve (*E*) the valve setter controls its operation. By holding this valve in his hand and pressing the button attached to valve stem, he allows air to exhaust, thus starting the machine, then by relaxing the pressure of his hand, stops the machine. Air pressure is on whether the machine is being worked or not.

This improved machine has been in use in these shops for the past two years, one man doing the work alone and setting the valves of engines up to

worse than the hammer and chisel champions of the last century. Anyone who has been a number of years at the trade

they may be made to fill in among a gang of skilled mechanics, but where a foreman has a majority of these half-breeds of the shop, it is a terrible thing to get a job done decently.

Then there is another class that might be mentioned: the so-called machinist's helper, a class of fellows who, having got started in some shop or other as laborers, or shop helpers, and who, when they first observed a real mechanic at work were filled with awe and reverence at what was accomplished, were one day given tools to help out during a rush, and thereby gradually acquired a slight smattering of the trade, so that they began to look down upon laboring work. Such men should not be entirely sat upon, because there are here and there some thoughtful men of latent ability whose early advantages were limited and who, through difficulty, come to be useful, but, generally speaking, they are utterly blind to their own inability and really have only the dimmest vision

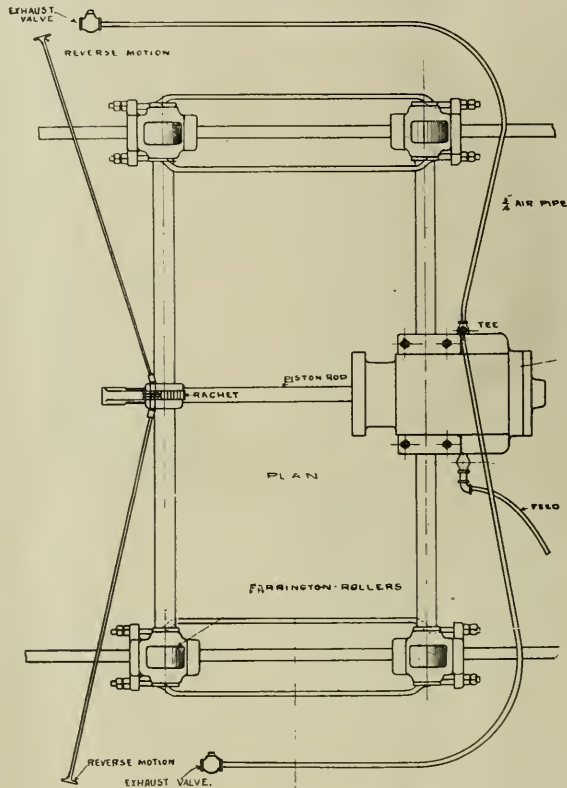

PLAN OF VALVE SETTING MECHANISM.

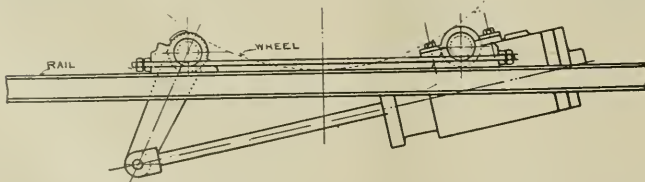

SIDE VIEW SHOWING OSCILLATING AIR CYLINDER.

22x30 in. cylinders and using an air pressure of 100 lbs. JOHN GOULETTE, Marquette, Mich.

The Modern Machinist.

Editor:

Your fine article on the Modern Machinist hit the nail on the head as far as the old fossils of last century were

knows that the long spell of good times has brought to these shores a horde of half-made mechanics from abroad, where people filled with conceit of themselves imagine that the least unskilled in their own country will do well enough in America. These men are willing to work for small wages, but are really worth little or nothing. After awhile they pick up a little smattering

of the scope of the trade. Such men are an endless source of trouble. One would excuse them for stealing their trade if they would only steal it effectually, but they only grasp a shadow of it.

bail the coal in the fire box, and in heavy freight service he will burn at least one ton more coal per one hundred miles with dry valves than if they are well lubricated.

G. H. & W. ENGINEER.  
Guineville, Tex.

#### Too Much Information.

It is not always safe to take a mere novice through an automobile factory to witness the manufacturing of a car. One prominent selling agent had an experience some days ago and now he waits until he has discovered whether a probable purchaser possesses in advance information regarding the true inwardness of an automobile. This particular selling agent was proud of his car, proud of the way it was made, and more than anxious to exhibit in the rough the fine material which went into its make up. He took his customers

many miles by train, and when in the factory exhibited to them every little part of the machine, thousands and thousands of them, so it seemed. Each part was shown to be vital to a good car, and when the day had been spent with still a great many parts not seen, as the agent explained, the customers looked at each other in blank dismay and that night they decided that this car had altogether too many parts, that it would be simply out of the question to ever remember the location of the thousand and one parts, and that, while they considered the car was made of good material and well put together they decided to wait for a time, until they could find a car made up of about one-quarter as many parts. The sale had been lost. Few users of automobiles ever stop to think of the number of parts required, over 5,000 as a matter of fact, to make up an automobile. Fortunately once put together hundreds and hundreds of these parts never separate and few if any break in

a good car. But the novice does not realize this.

#### Filling Engine While Being Towed.

Editor:

I would like to say that the method as explained by W. W. Donaldson, in the July number of RAILWAY AND LOCOMOTIVE ENGINEERING is correct in every detail. That is the way to do it. The nozzle should be left open to let the air pass out from boiler.

FRED WHITMORE.

Hillyard, Wash.

#### Second Hand Tools.

There is a very complete list of second-hand machinery suitable for use in railroad shops, issued by the Niles-Bement-Pond Company, of New York. The list is No. 12, and comprises a varied assortment of axle and wheel lathes, borers, etc., also screw cutting lathes, speed lathes, brass finishers' lathes, gap and other non-screw cutting lathes, screw machines, planers, shapers, drills, multiple spindle drills, bolt and nut machinery, cutting off and centering machines, tapping machines, milling machines, boring machines, punch and shears, grinding and polishing machines, blowers and forges, woodworking and other miscellaneous machinery. There are in all 332 machines listed, and the company will be happy to send a copy of the booklet



DINER ON THE CENTRAL OF CARDOVA.

The result is that between these foreign frauds and domestic thieves the trade is being gradually run into specialization. A very unskilled man can after a few months be hammered into doing a certain limited kind of work, and the foreman will persist in keeping him at it because it is about the only thing he can do. This melancholy view of the trade is not meant as a complete and comprehensive vision, but, rather, as filling in a background to the rosy view presented in your able article, and, doubtless, many of your readers who have had to live and move and have their troublous being among the non-descripts referred to will endorse my views.

W. L. CALVER.

Interborough R. T. Shops, New York.

#### Effects of Poor Lubrication.

Editor:

This letter is addressed to you in the hope that it will reach the eye of the railroad manager of to-day. It is in the form of three propositions, which are as follows:

First, do not skimp valves on oil. When your valves get dry, the engine gets lame; second, there is no engineer that will run a "lame" engine, if possible to avoid it; third, how can an engineer square his engine when the valves get dry? He must not use valve oil, as he is required to make so many miles on a certain amount of valve oil. Then in order to get his engine to exhaust square, he drops her down one or two notches, then the fireman has to



"LET GOOD DIGESTION WAIT ON APPETITE, AND HEALTH ON BOTH."—Shakespeare.

describing these tools to anyone who writes to them for a copy, and they will also be pleased to give further information on request.

# Railway and Locomotive Engineering

A Practical Journal of Railway Motive Power and Rolling Stock.

Published Monthly by

ANGUS SINCLAIR CO.,

136 Liberty Street, New York.

Telephone, 984 Cortlandt.

Cable address, "Loceng," N. Y.  
"Glasgow," "Locauto."

## Business Department:

ANGUS SINCLAIR, President.  
FRED M. NELLIS, Vice-President.  
JAMES R. PATERSON, Sec'y and Treas.

## Editorial Department:

ANGUS SINCLAIR, Editor.  
GEO. S. HODGINS,  
JAMES KENNEDY, } Associate Editors.  
J. F. KELLY,

## Advertising Department:

Eastern Representative, S. I. CARPENTER, 170 Summer St., Boston, Mass.

## British Representative:

THE LOCOMOTIVE PUBLISHING CO., Ltd., Amen Corner, Paternoster Row, London, E. C.

## Glasgow Representative:

A. F. SINCLAIR, 15 Manor Road, Bellahouston, Glasgow.

## SUBSCRIPTION PRICE.

\$2.00 per year, \$1.00 for six months, postage paid in the United States, Canada and Mexico. For other parts of the world, \$2.50 or ten shillings. Single copies, 20 cents. Remit by Express Money Order, Draft, Post Office Order or Registered Letter. Mailing address can be changed as often as necessary—always give old and new address, and if you subscribe in a club, state who got it up. Please give prompt notice when your paper fails to reach you properly.

Entered at Post Office, New York, as Second-class mail matter.

Copyright by Angus Sinclair Co., 1906.

For Sale by Newsdealers Everywhere.

## Modern Master Mechanics.

The recent convention of Master Mechanics at Atlantic City furnished a striking illustration of the fact that a new order of things has obtained on railways as well as in every other field of human activity. There was a time when the Master Mechanic was called from the ranks on account of some physical or temperamental attribute. Either he was a good workman himself, or he had the happy faculty of getting good work out of others, which is a masterly quality. Sometimes he was merely a mechanical miser who managed to get along on less outlay than another, and perhaps a better man in a similar position. His mileage reports were models of cheapness and as his figures decreased his stock rose in the estimation of the short-sighted powers that were. So various were the idiosyncrasies of these men that it would be difficult to classify them. They resembled each other in one thing only, that they all had some point that attracted the notice of their superiors. Sometimes it was the gift of the gab, and sometimes it was the golden gift of silence. To look wise and hold one's peace is always a shining quality in a commander.

Sometimes, this mechanical curiosity resurrected some forgotten variorum in mechanical construction and claimed it as his own, and grew fat on other men's brains. There was a western Master Mechanic who was credited with designing a new style of a boiler, the exact counterpart of which had been in use several years before his time. His improvement was a mere allegation. It was not visible except to the eye of faith, but the resurrector was much praised for his spoiling of the boiler, and had his portrait in the magazines.

There was another mechanical barnacle who acted as a kind of brake on the wheels of locomotive progress in Pennsylvania. He was nearly blind and perhaps could not see the condition to which the locomotives were reduced. He could hear, but the clashing of the loose joints of the engines that drowned in thunderous exhausts of the overworked freight engines, fell in his case, on inattentive ears. When he disappeared the motive power of the road took a sudden jump to the front rank and remains there.

We could multiply instances, but it is cruel to rend the mantle of self-complacency that so kindly enwrapped these relics of a vanished age. These men had their day. The pride of place filled their narrow minds to overflowing and they were satisfied. As Mr. G. M. Basford, of the American Locomotive Co., recently said in an able address before the Mechanical Engineering Society of Purdue University: "Thirty years ago the head of the mechanical department led a comfortable life. He could safely follow precedent and the strenuous life had not been invented. Labor wars had not begun, and the stirring emergencies of the present were unknown. It was easy to select shop machinery. There was no shop problem, no pooling of locomotives, no piece work price. There were emergencies, of course, but not the emergencies of today. The master mechanic knew all his shop men and the engineer and firemen. Each locomotive had a name and an engineer and firemen were assigned to it."

Mr. Basford might have added that when the engineer complained of the weakening parts of his engine his voice was like the voice of one crying in the wilderness. The engines were made to hobble along like a rheumatic, with an agonizing, radiating pain in the sciatic notch, till they literally came to a standstill. When the dilapidated machine could not run any longer, the engineer and fireman found themselves out of employment until the repairs were completed, when they all set off together again.

The master mechanics of that day doubtless did as well as they knew.

The twentieth century with its marvelous growth of complex mechanism calls for men of wider education as well as mechanical ability perfected by experience. Education of the minute, technical kind must be supplemented and made severely practical by personal contact with the mechanical appliances that are used in the harnessing of the elemental forces that move the traffic on the great steel highways. It also calls for special abilities of the organizing, executive kind. Nearly all of the younger master mechanics are either graduates of colleges or technical schools. Many have continued their studies at night while working at the bench by day. Nearly all continue to be students in the strictest sense of the word. Education gives them a broader vision of affairs than their predecessors had, and their estimates of men are juster and therefore kinder. The result is that out of the heterogeneous mass of employees coming into their hands, they have in a large degree the faculty of organizing effective sections and subdivisions that are readily adaptable to the work in hand. A gentleman recently appointed to be superintendent of motive power of a large trunk system, said to us soon after his appointment: "It is my ability to organize and administer my department which now counts for more than my mere ability as a skilled mechanic." In a word it may be said that generalship, in the widest and best sense, is the quality that distinguishes and will likely continue to distinguish the modern master mechanic.

## Locomotive Boiler Explosions.

No class of steam boilers, largely used in America, is so free from disastrous explosions as those used in our railroad locomotives, which is something remarkable in the presence of the fact that few boilers are run with a smaller safe margin of strength. Within the last few months there have been locomotive boiler explosions that direct attention to the subject. When a boiler explodes under a pressure which had often been carried before without signs of weakness, certain parties are sure to proclaim that some mysterious agency has been at work. In other departments of mechanical engineering, similar phenomena are of daily occurrence and pass without comment. A link in the chain of a crane breaks under a lighter load than the chain lifted two hours before, a crank pin breaks, not when the engine is working at its maximum power, but under comparatively light duty, a locomotive axle breaks when the engine is jogging along at a quarter the speed made the day before. Every intelligent engineer meets incidents of this kind every month, and knows how to account

for their occurrence. The same laws apply to the rupture of a steam boiler, that control the safety of a chain link, yet the men who readily perceive a rational cause for a chain breaking today under a lighter load than it carried yesterday, often fail to account in a natural way for a boiler exploding under ordinary working pressure and without warning.

No subject connected with the locomotive has received more careful attention from the Railway Master Mechanics' Association than the cause of boiler explosions, and the deliberate conclusion reached after years of patient investigation was that ordinary over-pressure alone caused boilers to explode. A boiler works along safely for months or years after being built or thoroughly repaired, and some deteriorating agent keeps operating upon it unnoticed till a weak link, in the shape of a corroded sheet or some broken staybolt gives way, and the boiler goes to pieces.

It is satisfactory to notice that the labors of the various master mechanics' committees on boilers appear to have produced good results; for, although the number of locomotives in the United States has been increased materially since 1875, the number of boiler explosions has been greatly diminished. The improvement is, no doubt, due to greater care and skill in designing, to better material used in construction, to more careful workmanship, and to the growing practice of rigid tests and searching inspection. This has been the line of policy advocated by the Master Mechanics' Association as the proper means for making locomotive boilers as safe as human agency can make a vessel containing the potentially destructive agencies inside a high pressure boiler, and the men who enforce this policy in their daily practice are the men who secure immunity from accidents. The safety of locomotive boilers, even those that have been well made of proper material, is secured only by the constant care and unremitting vigilance that will be sufficient to guard against and detect in time, deteriorating influence. When these are relaxed for any length of time, disaster is inevitable.

#### Fatigue of Metal.

The crystallization of metal particles, often called the fatigue of metals, is being constantly brought to our attention by the recurrence of accidents that might with a little forethought be avoided. The natural tendency of the highest grade of iron, whether rolled or hammered, is gradually to assume its original form of granulated particles. During the process of being manufactured into commodities the metallic

molecules assume a fibrous or stringy form, but no sooner is the metal left alone than it immediately begins to assume the crystalline form. It seems as if disintegration begins at once, though the process is necessarily somewhat slow. This process is, however, accelerated if the metal is subjected to severe stresses, and hence axles, cranks and pins gradually lose their elasticity and become brittle.

In locomotives and other machines subject to constant straining shocks the period of safety is practically known, and rules can be established, with a fair degree of accuracy, prescribing the distance in miles beyond which axles and other parts should not be allowed to exceed without examination. It is to be regretted that this system of regulation is not more generally applied. Usually some serious accident happens before the fatigue of metals is thought of. Very often much surprise is then expressed that a fracture occurs when some light work is being done, although work of a much heavier kind had previously been accomplished with the same machine without any appearance of weakening.

An apt illustration comes to us from a southern railway, where a draw-bar pin broke, causing the parting of a train of heavy cars, with disastrous results. Two weeks later another accident exactly similar occurred. The lesson thus doubly impressed was learned at last, with the result that a number of pins were tested and broken by a single blow from a sledge. The broken ends of the pins looked like burned steel. The annealing process was then promptly applied to the rest of the fatigued pins. Piles of them were covered by a hot wood fire, and they were allowed to cool in the ashes. The limit of six months' service is now fixed on the road in question for the service of draw-bar pins.

We recall an instance of a spring hanger breaking on a newly repaired engine, which established the practice of annealing the spring hangers and other parts on all engines on that road while repairs were being made in the back shop. This species of fatigue particularly applies to chains that are subjected to severe strains. It would be well if the process for softening the crystallized metal was more generally adopted. It is a singular provision in nature that calorification has the effect of renewing the elasticity of wrought iron, and the remedy so readily applicable is often overlooked on account of its very simplicity.

#### Locomotive Collision Study.

Those who went to the Brighton Beach race track on July 4 last, expecting to see a pair of locomotives broken

to fragments as one might smash an egg against a stone wall, were disappointed. There was a collision between two engines, and it was witnessed by a large concourse of people, but the engines used were not new, they were of the 4-4-0 type, and not particularly heavy, and did not sustain any excessive amount of damage.

This form of entertainment, designed to draw money from the pockets of the morbidly curious or the sensation tasters, was in one of the daily papers, dignified by the name of a collision study, but it was not much of a study, and the time the spectators on the ground had to wait for their fun was tedious.

At length, when all the gate money was in, the engines were started, and lumbered toward each other over well sanded rails, "to insure good traction," we were told. Just at the moment of "impact"—that is the word to use when dealing with a "collision study"—an escape of steam from the left rear cylinder cock of engine No. 2 was caught by the camera, and the "study" writer whose account we read, made out from that, that a puff "from the boiler of No. 2 indicates that the force of the blow had already started an outlet for the contents."

The usual things happened in this as in other collisions. The pilots were destroyed, the headlights fell off, and smoke boxes telescoped. Study writers treat smoke boxes very seriously, for in this case we are told that "great volumes of steam at once burst forth from their riven shells." The left cylinder and steam chest of No. 2 broke off and fell to the ground, and the tanks moved up the distance of the gangway—and all was over. We might mention, however, that the sand box of No. 2 was tilted a little forward by the awful force of the terrible blow, and a small hill of sand formed below the pipe, showed that at the moment the "monsters crashed together" this sand pipe was either working all right or had whatever obstructions that may have been in it, jarred out.

The rearranged collision of two engines as a pastime may or may not be interesting, according to how one feels about such things, but certainly there is no "study" in it, and no new facts come to light that way. When two engines collide on a single track railroad, the disaster is generally the result of human forgetfulness or human carelessness, and is usually accompanied with loss of life. Under such circumstances it is a matter to be deplored by all right thinking people. If such performances as the one at Brighton Beach could teach us how to eliminate collisions, there might be some justifi-

cation in them beyond the money maker's desire for gain. Locomotive engines are not designed for the purpose of resisting the effects of a collision, and never will be, unless railroad operation becomes worse than it is, and exhibitions of what are, as a rule, the results of human weakness or frailty are not in the catalogue of things which add anything of value to the sum of human knowledge.

#### Wise Eyes Are Odd.

The expression at the head of this article is true enough as far as it goes. Wise eyes, in the sense of observing eyes backed by a comprehending mind, are not as common as they might be, and may therefore be described as rather out of the ordinary, and consequently as odd. Perhaps one may think of the eyes of Minerva's bird of wisdom as being uncommonly thoughtful, and in that sense odd. There is, however, another use to which this little expression may be put besides that of stating a proposition which is more or less generally true.

We have on modern locomotives two kinds of valve motion, the direct and the indirect, and we have also outside and inside admission valves. In setting the eccentrics of a locomotive we have therefore four combinations to deal with, and they may be summarized as follows. Beginning with the most common, viz.: outside admission valves, with indirect connected motion, called, for short, outside-indirect. The others are, of course, outside-direct, inside-direct, and inside-indirect.

The position for the eccentrics of these four combinations may be stated as follows: The outside-indirect has eccentrics so placed that when the crank is on either dead point, the center line of each eccentric is on the same side of the vertical line passing through the axle on which the crank lies. In other words, if we consider the path of the crank pin as a circle cut by a plumb line standing, as it would do, at right angles to the track, then the half of this circle containing the crank pin would also contain the centers of the two eccentrics.

If this mental picture is drawn with sufficient accuracy, it will be seen that the center line of the crank and of the two eccentrics make a figure like the outline of an arrowhead, or like a tent where the supporting pole stands for the crank, and the sloping sides of the tent represent the eccentric center lines. On examination it will be found that the inside-direct also has eccentrics arranged in this way.

When it comes to the inside-indirect and the outside-direct, we find that the center lines of the eccentrics lie in that half of the crank circle remote from the

crank pin. These center lines thus make an outline like the letter "Y," and here comes in the use of the expression given above, lest we forget just how the eccentrics should be placed for each of the combinations.

When the four combinations are written down, with the initials used only, we have a set like this: OI, ID, II, and OD. The first two, as already explained, have the arrowhead arrangement of eccentrics, and the last two use the arrangement like the letter "Y." As an aid to memory, the letters YY may be put in front of those indicating the inside-indirect and the outside-direct. These last two may be separated by the letter "R," so as to have a verb in the sentence, and also to indicate by the initial that the eccentric center lines are in the half of the crank circle "remote" from the crank pin.

With all this before us, and it places a little complicated at first, we place some of the letters so that they will be a help to memory, and we get a line of letters which looks like a formula in mathematics, but it is simple enough after all. The line is YY. II. R. OD., or, to put it into words, "Wise Eyes Are Odd." This is true, in a general way, of an observing pair of optics, but it is strictly accurate when applied to the position of the "Eyes" and the "Odd" eccentrics, which with the line of the crank, always make a "Wise" outline.

#### Once Used, Never Again.

We hear a good deal from time to time about railway passenger car sanitation and various schemes are advocated having for their object the disinfecting of coaches and the removal of everything likely to harbor disease germs. In view of the perfectly preventable nature of that dread disease, consumption, the U. S. Consul in Paris has given some valuable facts and figures concerning the organized efforts in that country to prevent the spread of tuberculosis in France.

Speaking of a rather ingenious invention, he says:

"The tuberculosis commission has been examining a cuspidor invented by M. Fournier. It is of very cheap construction, and needs no cleaning or touching by hand. It consists of a cardboard cylinder rendered waterproof, containing some pulverized peat impregnated with some hygroscopic and antiseptic substance. This receptacle is provided with a lid, which rises on pressure of a small hand lever or foot pedal, and thus nothing objectionable is in sight, no dust can come from it, and flies cannot enter. When it needs emptying it can be seized with a pair of tongs and thrown on the fire."

This kind of thing might be used in the smoking compartments and other parts

of a railway car with advantage, and when it gets to the point where it requires cleaning it can be destroyed. The idea is good, and the article cleanly and sanitary. The State department of public charities in France is going into the matter of disease suppression in earnest, as it regards the struggle against tuberculosis as a national and social duty, and not merely as good practice. Our railway surgeons and others in authority might perhaps with advantage look into the merits of some such device as a "once-used-never-again" cuspidor for general station, platform and coach use.

#### Robbed of Sleep.

There is a certain class of man who always has time to engage in a gossip with business acquaintances, and nothing delights him so much as talking to an editor. Some of these people have staying qualities that would make them rich if their abilities were only devoted to useful purposes. While the writer was suffering from a visit of the gossiping bore he uncovered a panel bearing the inscription: "He who takes the time of an editor robs him of sleep." The man read the words, laughed heartily and remained half an hour longer.

There is an etiquette of visiting business men that every sensible person adheres to. Visit business men in business hours only, make known your business in as few words as possible and then go about your business. Always let your dealing with a stranger be most carefully considered. Leave tricks of trade to those whose education was never completed. Treat all with respect, confide in few and wrong no man. Be never afraid to say "No;" and be always prompt to acknowledge and rectify a wrong. Because a friend is polite do not think his time is valueless. The way to get credit is to be punctual; the way to preserve it is not to use it much. Settle often; have short accounts. Trust not too much to appearances. Rogues generally dress a shade or more better than well.

#### Book Notices.

The Car Builders' Dictionary. By Rodney Hitt. Published by the Railroad Gazette, New York, 1906. Price, \$6.00.

This is the fifth edition of the work, and in its compilation the editor has been assisted by a committee of the M. C. B. Association, composed of Messrs. C. A. Seely, H. F. Ball and J. E. Muhlfeld. The general arrangement of the book is similar to the previously issued editions. The illustrations have been revised so that new and improved devices appear and about 200 pages of illustrations have been added. The book contains 568 pages.



Illustrations of British cars and practice form an important addition to the subject matter of the book. This feature will be appreciated by manufacturers and others seeking to extend American trade in the various parts of the Empire where British practice is followed. A revision of the definitions has been made with the view of bring-

water cooling, feed pumps and injectors. The book should be instructive to those interested in the subject of water treatment for steam boiler use.

#### Express Companies in Canada.

The Toronto Sun says that the Government and the opposition have united

#### Texas & Pacific 4-4-2.

Our illustration shows a simple 4-4-2 engine recently built in the shops of the Texas & Pacific Railway, which are situated at Marshall, Tex. Mr. J. W. Addis is superintendent of motive power and rolling stock, and it is to him that we are indebted for the photograph and information concerning the engine and the newly built erecting shop.

The engine has cylinders 20x28 ins., balanced D-slide valves and 79 in. driving wheels. The tractive power developed by this machine is about 26,500 lbs. and with 116,000 lbs. on the drivers; the ratio of tractive effort to adhesive weight is as 1 is to 4.37. The valve motion is indirect, Stephenson type, and the radius of the link is 56 ins. The transmission bar is attached at one end to the lower end of the rocker and at the other to a hanger back of the link. The bar is made with an almost circular loop which completely surrounds the forward driving axle. The bar is continuous over the axle and the lower sweep of the loop is made in a separate piece and is bolted up so as to eliminate any tendency to spring which the crooked transmission bar might otherwise develop.

The driving springs are underhung, the forward end of the front one being attached to a curved cast steel bracket which is attached to the lower frame bar about opposite to the end of the guides. The trailing truck is equalized with the drivers, and has 56 in. semi-elliptic springs carried on top of its outside bearing journal boxes.

The boiler is composed of three cir-

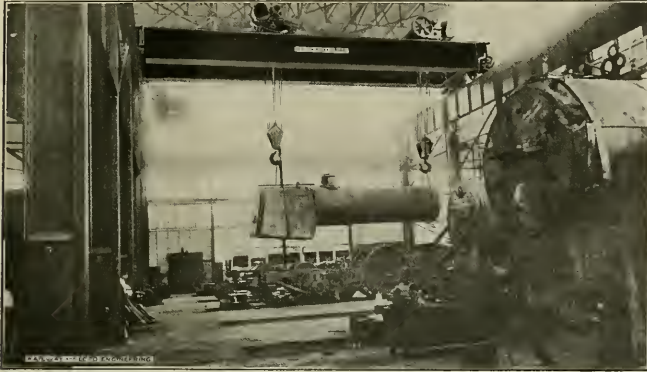

LIFTING A BOILER, TEXAS & PACIFIC SHOPS, MARSHALL, TEX.

ing the work up to date in every particular and such words as have gradually taken on a new meaning within recent years have been carefully dealt with. There are 6,344 illustrations in the book and the whole field of the car builders' vocabulary has been included.

**Water Softening and Treatment.** By Wm. H. Booth. Published by D. Van Nostrand, New York, 1906. Price, \$2.50.

This book contains 903 pages, 100 illustrations and is 6x9 ins. in size, bound in cloth. The author does not deal particularly with railroad plants, he treats the whole question of water softening for boiler use in a comprehensive way. He goes into the subject of the composition of natural waters, and while no attempt is made to enter into the finer points of chemistry, yet the principles of water treatment which he elucidates are capable of practical application to railroad work. Chapter VIII is concerned with apparatus in commercial use, and deals with settling tanks, continuous process, application of re-agents and proportions and cost of water softening. Chapter IX gives examples of some forms of the apparatus used. There is a chapter on filters, another on boiler compounds, and another on mechanical boiler cleaners. A chapter is devoted to the corrosive effects of acid waters, and there is one on oil separation. Air pumps, condensing apparatus and circulating pumps are taken up. Feed water heating is dealt with, also

in the Canadian Parliament in the drafting of legislation designed to secure the control of express rates by the Railway Commission, and counsel for the express companies, recognizing the fact that such regulation was bound to come from some source, has bowed to the inevitable and withdrawn his contention that regulation is beyond the

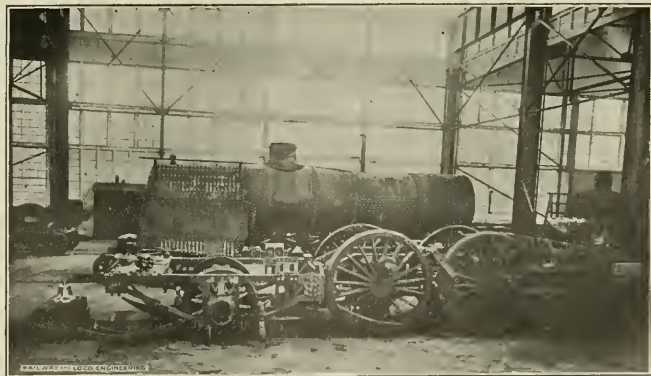

INTERIOR OF TEXAS & PACIFIC SHOPS AT MARSHALL, TEX.

constitutional limits placed on the federal power. The result will be legislation this session giving the Canadian Railway Commission the same control over express rates that it now has in the matter of freight charges and passenger fares.

cular courses, the front one measuring 70 ins. in diameter. The second course is taper, and slopes up to meet the third or dome course which is 77½ ins. diameter outside. The roof and crown sheets are level and the back and throat sheets slope forward. The tubes are

16 ft. long and the heating surface which the 326 of them give, amounts to 2,731 sq. ft., and with the 160 of the fire box, the total comes up to 2,911 sq. ft., and this is a little over 64 times the area of the grate, which measures 45.3 sq. ft. The boiler is fed by two No. 9 injectors and the top check which is single is placed well forward and on top of the first course, just in front of the sandbox. The back sheet and the front flue sheet are held by stayrods carried back at an easy angle to the roof, and to the upper part of the first and gusset courses, respectively. The crown sheet is radially stayed.

The tender frame is made of steel channels. The tank holds 6,500 U. S. gallons of water and carries 10 tons of coal. The weight of the engine in work-

joint, sextuple riveted; seams, circumferential, double riveted.

Fire Box—Length, 8 ft. 3 ins.; width, 6 $\frac{1}{2}$  ins.; depth, front, 6 ft. 5 ins.; depth, back, 5 ft. 9 ins.; material, carbon steel; sides, crown and back,  $\frac{3}{4}$  in. steel; front tube sheet, 9 $\frac{1}{2}$  in.; back,  $\frac{1}{2}$  in.; water space, sides, 5 ins.; back,  $\frac{3}{8}$  ins.; front, 4 ins.; fire box stay bolts, Falls hollow.

Tubes—No. 11 gauge; 2 ins. diam.

Exhaust Pipe—Single.

Smoke Stack—15 ins. inside diameter; above rail, 15 ft. 5 ins.

Tender Tank—Style, water bottom.

Weight—Tender frame, light, 50,000 lbs.

Wheels—Diameter, 33 in. steel tire.

Journals— $3\frac{1}{2}$  x 10 ins.; M. C. B.

Wheel Base—18 ft. 2 ins.

#### Convenient Summary of Tests.

This is in convenient form, a compilation by Dr. W. F. M. Goss, of Purdue University, from the recent book published by the Pennsylvania Railroad, describing the locomotive tests and ex-

#### Louisville & Nashville Trees.

An experiment in tree growing is being made in Alabama, under the direction of Louisville & Nashville officials. About a year ago the company purchased about 1,040 acres of land, and planted catalpa trees to be used for fence posts and ties. They have completed the planting of trees on 350 acres, 900 trees to each acre. In the fall the company will fill the remaining 690 acres with catalpa trees. If the experiment proves to be a success the cultivation of these trees will be undertaken on a larger scale.

#### Poor Lookout for Train Robbers.

If anyone is thinking of going into the train robbing business, the experience of the three men who held up a Canadian

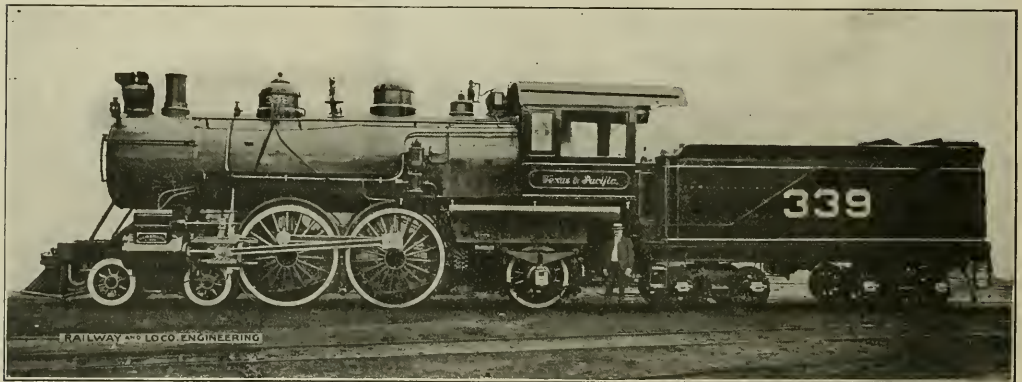

4-4-2 PASSENGER ENGINE ON THE T. & P.

J. W. Addis, Superintendent of Motive Power and Rolling Stock.

Texas & Pacific Railway. Builders.

ing order is 204,000 lbs., and with the tender the total is 336,000 lbs. The wheel base of the engine and tender is 55 ft. 6 ins. The engine is altogether a substantial looking machine, and Mr. Addis is shown in our illustration, standing beside it. The principal dimensions are as follows:

Fuel—Bituminous coal.

Weight—On drivers, 116,000 lbs.; on trucks, 43,000 lbs.; on trailer, 45,000 lbs.

Wheel Base—Driving, 7 ft.; rigid, 16 ft. 6 ins.; total, 27 ft. 7 ins.

Cylinders—Diameter and stroke cylinders, 20x28 ins.; horizontal thickness of piston, 6 $\frac{1}{4}$  ins.; diameter piston rod, 3 $\frac{3}{4}$  ins.; piston packing, cast iron snap rings; piston head.

Valves—Greatest travel of valve, 3 $\frac{3}{4}$  ins.; outside lap, 1 in.; negative exhaust lap, 1 $\frac{1}{16}$  in.; lead of valves in forward gear, line and line; lead of valves in back gear,  $\frac{1}{4}$  in. negative.

Wheels—Driving wheels, cast steel centers, 72 ins.; tire held by shrinkage; driving boxes, phosphor bronze; driving journals, 11 ins. diam., 12 ins. long; trailer journals, 10x14 ins.; trailer wheels, 51 ins. diameter outside; crank pins, mains, 6 $\frac{1}{4}$  ins. diam. by 6 ins. long, and 7 ins. diam. by 5 ins.; crank pins, front, 3x4 $\frac{1}{2}$  ins.; rods, carbon steel, 1 section; engine truck, 4 wheel rigid; engine truck journals, 6 ins. diam. 10 ins. long; engine truck wheels, 36 ins. diameter.

Boiler—Working pressure, 220 lbs.; material, carbon steel; thickness of plates in barrel, 13 $\frac{1}{16}$  in. and  $\frac{3}{4}$  in.; seams, horizontal, butt

hibits of that road at the Louisiana Purchase Exhibition. It has recently been issued by the American Locomotive Company. This pamphlet presents in concise form, an account of the locomotive tests at St. Louis, giving specific information concerning each of the locomotives tested and presenting the results separately for each of the eight locomotives experimented with. In the pamphlet four pages are devoted to a description of each locomotive and to a discussion of its performance, including a summary of the data of the tests. This is followed by comparisons and conclusions compiled by Dr. Goss from the very elaborate record of the tests in the Pennsylvania book. While the pamphlet does not add to the information given in the book, it presents the conclusions and comparisons in convenient form for reference. For a more complete record the book published by the Pennsylvania Railroad may be consulted. Copies of the pamphlet may be had on application to the American Locomotive Company. Those interested in this subject should apply at once.

Pacific train near Kamloops, B. C., should be sufficient to convince them that Canada does not offer an inviting field for their energies. The train was held up on May 8. On May 14 the men were captured, and on May 19 had their preliminary hearing and were committed for trial. On May 28 the grand jury returned a true bill against them, and the next day their trial began. May 30 the jury disagreed, one Socialist, who was opposed to punishing men because they were poor, having held up a verdict of guilty the remaining eleven were anxious to render. A new trial was begun next day, and on June 1 the three men accused were found guilty and sentenced, two to imprisonment for life and one to twenty-five years in the penitentiary. Twenty-five days elapsed between the commission of the crime and the day on which the penitentiary doors clanged behind its perpetrators, doomed to spend the remainder of their days within its walls. Train robbers will hereafter carefully avoid working at their trade in Canada. It is not safe.—Montreal Gazette.

# Our Correspondence School.

In this department we propose giving the information that will enable trainmen to pass the examinations they are subjected to before being promoted. If any of our students fail to understand any part of the instructions, we will gladly try to make them plainer if they write to us. All letters intended for Our Correspondence School ought to be addressed to Department E.

### Third Series—Questions and Answers.

31. When a new time-table takes effect, what does it supersede?

A.—It supersedes the time-table previously in force and all supplementary time-tables previously issued.

32. If the time given for a train be the same on the new time-table as on the old, how shall the train proceed?

A.—It shall proceed on the new schedule as it did on the old ones.

33. If the train, by reason of being late on the old time-table or by reason of being scheduled earlier on the new table than on the old, has not reached a point at which, by the new table, it should be at the time the new table takes effect, how shall it proceed?

A.—It shall proceed as the train named in the new time-table running late.

34. If the train be scheduled later on the new table than on the old one, how shall it proceed?

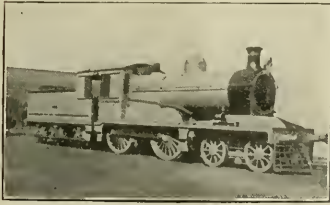

ROYAL TRAIN ENGINE ON THE BOMBAY, BARODA & CENTRAL INDIA.

A.—It should wait until its regular time on the new time-table before proceeding.

35. If a new train is shown on a time-table for an intermediate station at or subsequent to the time the new table is to go into effect, should it be considered that there is a train due that day at the time given at each station between such intermediate points and the terminus?

A.—Yes.

36. How many sets of figures may be shown upon the time-table for a train at any station?

A.—Two.

37. How are regular meeting and passing points indicated on the time-table?

A.—By heavy, full-faced type.

38. When there are two times (or set of figures) given at a station, what is each?

A.—One is arriving time, and the other is the leaving time.

39. When both the arriving and leav-

ing times are shown in full-faced type, what does it signify?

A.—When both are meeting or passing times or when one or more trains are to meet or pass it between those times.

40. If but one time is shown in ordinary type?

A.—This indicates that the time shown in ordinary type is not a meeting or passing time.

41. If but one time is shown in full-faced type?

A.—That is the time for meeting or passing another train.

42. How are the days upon which trains are to be run indicated on the time-table?

A.—By stating the day upon which the train does not run as daily except Sunday.

43. If, for example, your train is scheduled to run daily except Monday, and by the time-table it starts on Sunday before midnight and completes the trip after midnight, which would be Monday morning; can this train proceed?

A.—Monday morning begins after midnight Sunday, so the train can proceed.

44. What do the signs "s," "f" and "¶" indicate?

A.—"s" means regular stop, "f" indicates a flag stop, and "¶" shows that a stop is made for meals.

45. How are trains designated on the time-table?

A.—As regular or as extra trains.

46. What is requested of all employes whose duty it may be to give signals?

A.—We must provide ourselves with the necessary appliances or these appliances must be in good order.

47. What signals are to be used by day, and what by night?

A.—Hand flag, audible signals by day.

48. What colors are used for signals by this company?

A.—Red, green and white.

49. What does red signify?

A.—Stop; it is also used as marker lights at the rear of a train.

50. What does green signify?

A.—Proceed, and it is used for marker flags.

51. What does white signify?

A.—A white light on the back of a tender signifies that the engine is backing, a white light on the running board or center of a car signifies that train is being pushed by an engine.

### Calculations for Railway Men.

BY FRED H. COLVIN.

Levers play such an important part in the mechanics of the locomotive, the car, and in fact all manner of machines that we can well spend a little more time on it. If we thoroughly understand leverage we have mastered quite a good portion of the principles which underlie all mechanics.

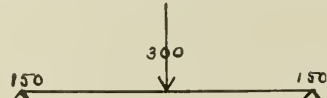

FIG. 1. PRESSURE EVENLY DIVIDED

Heretofore we have dealt with levers as transmitting power, such as in brake systems, but there is another service equally necessary, the carrying and distributing of loads. We find this in locomotives and cars in the shape of "equalizers." Before these were used the weight was carried on different pairs of wheels independently, and this made a hard riding engine; it was also harder on track. In 1837, Eastwick and Harrison, of Philadelphia, introduced the equalizer on their locomotives in practically the form they have since been used. Thomas Rogers is credited with being the first to use the equalizer between the driving and truck wheels.

In Fig. 1 we have a weight or pressure of 300 lbs., pressing down in the center of a rod or beam. It does not matter as to the length of the beam as long as the pressure is in the center, for the weight will be borne equally by each bearing, giving a pressure of 150 lbs. on each point.

In Fig. 2, we have shifted the weight to the left, so that it is one-third the

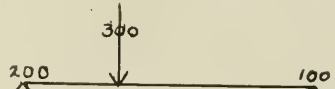

FIG. 2. PRESSURE NEARER ONE END.

distance from the left hand support and two-thirds from the right. It is plain that the most pressure will be exerted on the point of support nearest the load, and you can easily prove this with a stick, a weight and a pair of ordinary spring balances. As the load is moved near the end of the stick supported by the balances, the amount supported by them will be gradually increased. In this case the left hand point will support two-thirds the load, as we can see

by calling the short end 2 ft. and the long end 4 ft. Multiply the 2 ft. by 200 lbs. and get 400 ft.-lbs. Multiply the 4 ft. by 100 lbs. and get the same thing, 400 ft.-lbs. at the other end. In cases of this kind it is evident that the pressure multiplied by its arm, in each case, must be equal, as in all leverage examples. Now let us apply this to a car truck and see where its usefulness comes into everyday railroading.

With the four wheel truck we have the load evenly distributed between the

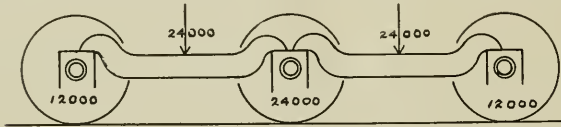

FIG. 3. LOAD IN THE CENTER OF EACH EQUALIZER.

two axles by the bolsters bearing, through the use of springs, on the equalizing beams so to throw the same load on each axle. But when we come to the case of a six wheel truck, such as is found under Pullman cars and heavy express cars, it is a different proposition.

Fig. 3 shows, in outline, the three wheels and the equalizing beams across on the top of the boxes. Suppose we put the load in the center of each beam as shown. We then have a load of 24,000 lbs. on each beam, evenly divided between the two ends. This means that end will carry half the load, or 12,000 lbs. This is the same for each lever and it can be readily seen that the center axle carries one end of each axle, so it carries twice 12,000 lbs., or 24,000 lbs., while the end axles carry but 12,000 lbs. This is not good practice, although I have seen it done on private cars owned by a well known firm.

The correct way is shown in Fig. 4, and will be found in the practice of the best car builders; in fact no one thinks of doing it in any other way at this stage of the game. Here the load is placed one-third the distance each outer wheel, just as we moved the load on the lever in Fig. 2, so as to divide the load into thirds. In this way each lever puts 8,000 lbs. on the central axle, making a total load of 16,000 lbs., and each end axle carries the same loading, so that the work is evenly divided.

When you see equalizers on locomotives with unequal arms it is because they wish to throw more weight on one wheel than another, as in the case of equalizing the truck with the drivers. Traction increasers are sometimes made so as to throw the fulcrum from one point to another to give more weight on drivers in cases of emergency. Wilson Eddy, away back in the 50's, made a toggle arrangement, which lifted the tank and threw part of the weight on

the tender. This worked automatically, so that the harder the engine pulled the more extra weight came on the drivers. Winans, in 1851, patented a steam cylinder over the drivers to raise the weight of boiler and throw it on driving wheels. But the lever principle is the best.

#### Electric Headlight.

For the benefit of railroads using the Edwards' Electric Headlight, we give

is forced across the space as the carbon slowly draws away from the negative. The arc, that is, the light itself, is nothing more than a shower of carbon dust heated to a white mass and thrown off from the carbon point, while the electric current passes from the carbon to the negative.

4. If light burns all right while engine is standing, but dies down while running, where would you look for the trouble? How would you remedy it?

A.—That may be due to a cramped turbine exhaust, if connected into main exhaust of locomotive, or it may be caused by loose connections. I would examine these parts carefully and make such repairs as seemed necessary.

5. If the light flashes and goes out and repeats this several times, then goes out entirely, what would be the cause?

A.—Cross circuits.

6. If the light burns all right when engine is standing but dies down when running, and the faster the locomotive runs the more the light runs down, what would be the cause?

A.—Answer to No. 4 covers this question also.

7. If the light dies down on pulling out from the station, what is the matter?

A.—Turbine is working water instead of dry steam.

8. If the light flashes and goes out for a second, then burns brightly for a second, and keeps on repeating this operation, where would you look for the trouble?

A.—The trouble is with the carbon. It is too soft and should be replaced with a new one.

9. If the light burns very dimly and engine is working hard and cab lights are bright, where is the trouble?

A.—With the lamp. It is heavily grounded.

10. What should be made sure of when putting in carbons?

A.—That the carbon is firmly secured in the carbon holder.

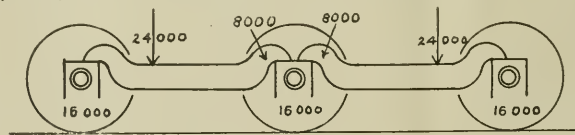

FIG. 4. LOAD AS IT IS IN PRACTICE ON RAILWAYS.

resistance, it passes, the instant the carbon touches the negative, through series coil up to carbon holder down the carbon (83) through negative holder to negative brush, its starting-point.

3. Describe the arc and explain how it is formed?

A.—While the current passes through series coil, magnet is drawn down. This in turn causes the carbon to draw away from the negative, and as the circuit was established the instant the carbon came down on the negative, the current

11. If copper electrode burns off during the trip, what is the probable cause? What effect does it have on the light? Can it be prevented from burning more? If so, how?

A.—The speed of the turbine is too high and throws the light into the air. Burning the electrode can be prevented by throttling down turbine or shutting it off entirely for a minute.

12. Why should the copper electrode be clean both on the point and where it passes through the holder?

## Questions Answered

A.—In order to make a good contact.

13. Give different causes for light burning green. What must be done to stop it burning green?

A.—Speed is too high or wires have been reversed, either at the lamp terminal or at the dynamo. Change wires at either lamp or dynamo.

14. If commutator becomes rough and out of round, what should be done with it?

A.—It should be turned and trued up.

15. How and when should commutator be cleaned?

A.—With sandpaper, whenever necessary.

16. What is the bad effect of holding sandpaper any other way except by the ends?

A.—It produces an uneven surface on the commutator.

17. Why should the mica strips in commutator be kept below the copper?

A.—To prevent the brushes from riding on top of mica causing the commutator to spark and finally breaking the circuit entirely.

18. Why should sandpaper be used on commutator and not emery cloth?

A.—Because sandpaper is a non-conductor, and, besides, it will not cut as emery does.

19. Is it necessary to put oil in turbine? What kind and how often?

A.—Yes, only on journal and governor whenever oil rings fail to carry up oil to bearing. Valve oil should be the only kind used.

20. How and when should armature bearings be oiled?

A.—By pouring oil into the oil chamber whenever oil rings fail to carry up the oil. Engine oil should be the only kind used on dynamo.

21. What is the purpose of tension spring (93)?

A.—Its purpose is to draw away carbon from negative.

22. If it is too tight, does it affect light burning with low steam pressure? If it is too loose, what is the effect?

A.—If it is too tight, the arc will break momentarily; if it is too weak, the light will not burn bright with the proper steam pressure.

23. If the commutator sparks badly, what should be done?

A.—See to it that the face of the top brush where it runs on the commutator is directly under the center of middle bolt on dynamo housing, and that commutator is clean.

24. Should commutator be cleaned endwise or around?

A.—It makes no difference with the Edwards' equipment.

25. If light does not start when turning on steam, what should be done?

A.—Press down on all the brushes at the same time until light starts.

### SLIPPING AT SLOW AND FAST SPEEDS.

(70) G. M. M., Minot, N. D., writes:

I would like an opinion as to whether an engine will do herself more damage slipping when running fast than when running slow. My argument is that there would be more change in speed when an engine catches the rail after slipping at slow speed than after slipping when running fast, but I think there must be some argument on the other side. A.—When an engine, pulling a full load, is just moving, and slips, with throttle wide open, the revolutions of the driving wheels are numerous compared to the distance moved over, and energy is rapidly accumulated by the slipping wheels. When they catch, nearly all this energy is converted into work, which appears either in the form of a sudden acceleration of the train speed or a sprung side rod or a damaged part, or if it results in a jerk, the train will very likely be broken in two. Suppose, however, that this engine slips when moving 20 or 30 miles per hour. The increase in the number of revolutions, above those which the speed requires, is not as great in proportion as in the former case, and when the wheels catch, there is not relatively so much rotating energy to be dissipated as at slow speeds, and consequently less jar or jerk takes place.

### BROKEN EQUALIZING RESERVOIR PIPE.

(71) J. A. C., Jackson, Mich., writes:

If the brake valve equalizing reservoir pipe, H<sub>5</sub> brake valve, breaks off, how can I fix up the valve so as to operate the brakes safely? A.—Place a blind gasket in the equalizing reservoir union at the brake valve T connection and plug up the brake pipe service exhaust port. When making a service application with the valve in this shape, do so by carefully moving the handle beyond service position into emergency position and, when the desired reduction is made, move it gradually back to lap.

### SLIPPING SHUT OFF.

(72) J. S. T., Green Island, N. Y., writes:

We have an engine that slips hard when throttle is closed at high speed. The engine is a light one, 17x24 in. cylinders. What is the cause of the slipping? A.—There was quite a discussion of this problem of "slipping, shut off," carried on in the columns of RAILWAY AND LOCOMOTIVE ENGINEERING in the year 1904, and the letters which were written and the explanations given can be had by turning to the index for that year. In dealing with this matter in our

March, 1904, issue we said: The expression "slipping when shut off," is misleading. Many persons seem to think that under the circumstances described the wheels are revolving faster than the speed of the engine would warrant. As a matter of fact, the wheels are not revolving as fast as they should for the speed of the engine, but the peculiar jarring effect produced very closely resembles the sensation caused by ordinary slipping under steam pressure, and has no doubt been mistaken for it. With throttle shut off, there is nothing to make the wheels spin round ahead of the speed, but there is every reason with bent pins or twisted axle or engine out of quarter, to have the motion of the wheels slightly retarded, and a slipping sensation produced.

### LEAKY PIPE CONNECTIONS, E. T. BRAKE.

(73) C. C. L., Elkhart, Ind., writes:

I am running a locomotive that has the new Westinghouse engine and tender brake, and I notice that whenever I apply the brake with the automatic brake valve, unless I lap the handle of the independent brake valve, the brakes gradually leak off. Can you give us a reason for this, or tell us what to do to remedy the trouble? A.—When the locomotive brakes are applied with the automatic brake valve (H-5), application chamber pressure is had in the pipe which connects the automatic and the independent brake valves, if the handle of the latter is in running position; therefore, should leakage exist at any of the joints or the unions in this pipe, the locomotive brakes would leak off, since leakage in this connecting pipe would reduce application chamber pressure. Placing the independent brake valve on lap cuts off the pipe connection between the brake valves from the application chamber; hence prevents any further leakage from it of application chamber air, and, consequently, leaking off of the locomotive brakes. To remedy the trouble of which you complain make the pipe and its connections between the automatic and the independent brake valves absolutely air tight.

The application chamber pipe is the one leading from the distributing valve to the independent brake valve and through this brake valve by means of ports and passages to the automatic brake valve. The double heading pipe is the one leading from the distributing valve through the double cut-off cock to the automatic brake valve. Both the application chamber and the double heading pipes should be kept absolutely air tight in all their connections.

### LEADING DRIVER FLANGE CUTTING.

(74) L. S., Poughkeepsie, writes:

The wheel flanges of a locomotive just out of the repair shops began cutting on one side. The subject created much discussion here, and to settle a

dispute we would like to have your opinion in regard to the matter. A.—In the absence of data as to the type of locomotive, there may be two causes that lead to the result alluded to. The front truck casting, if there be a truck, is not exactly in the center. More likely, the engine truck spring is defective or broken, and when such is the case, the leading driver on that side usually cuts its flange. Leveling up the truck is the remedy.

#### BROKEN STEAM CHEST.

(75) R. F. Laramie, Wyo., writes:

We had a slight collision resulting in breaking of a steam chest on one of our engines, and it had to be hauled a long distance to the repair shops. What would have been the best thing to have done with an engine, not otherwise seriously damaged? A.—Much would depend on the kind of material at hand, suitable for closing the steam ways. Perhaps the simplest and surest plan would have been to have slacked the bolts at the bottom of the branch pipe and removed the brass ball ring and put in its place a piece of plank, if possible, faced with rubber, and tighten up the bolts again so as to hold all snug. If no plank was available, we have seen a piece of an old shovel cut and slipped in on top of the flat side of the ball ring and tightened up enough to prevent a bad leak. The valve rod, and, where there is time, the main rod, should have been taken down and the locomotive run in on one side.

#### NEW YORK ENGINE EQUIPMENT.

(76) J. E. H., East Buffalo, N. Y., writes:

We have recently been on some passenger engines equipped with the New York improved brake valve, straight air brake and pressure controller, and the information I would like about it is this: 1. Why does the tender brakes apply when the handle is placed in release position with light engine? A.—When the handle is placed in full release, air from the brake pipe goes to the driver brake cylinder, and if the pressure controller does not open, this will cause a reduction in brake pipe pressure sufficiently heavy to operate the tender triple and apply the brake.

2. To test the ability of the No. 5 pump to keep up pressure, we opened the rear angle cock on the train five cars, and found that the brakes did not apply for several seconds. If this pump can furnish air as fast as the opening through the angle cock can carry it away, what is the train crew to do when they want to stop as in case of emergency? A.—The failure of brakes to apply for several seconds after the angle cock was opened was not due to the capacity of the air pump primarily, but rather to the size of ports in the brake valve, and to

the location of the pressure controller and its method of operating, which, when the brake valve handle is in running position, provides a large direct opening from the main reservoir into the brake pipe. Hence, a No. 5 pump working at about 50 cycles per minute, which is the usual rate, and a main reservoir containing from forty to fifty thousand cubic inches, could easily sustain brake pipe pressure for several seconds against the open angle cock, and prevent emergency application of the brakes; from this it follows that the brakes would not be likely to apply from the conductor's valve at least for quite a while after the valve was opened, unless possibly it were the conductor's valve on the rear car that was used.

3. How would the train crew in case of emergency apply the brakes? A.—Open several conductor's valves, as soon as they can be reached.

4. We had a case of brakes sticking, or not releasing promptly when handle was placed in running position, and I noticed that train pipe pressure increased very slowly. Can you give a reason for this? A.—Probably the pressure controller supply valve did not open up wide as it should, due to the vent port above the supply valve piston becoming plugged up with dirt.

#### GALVANIC ACTION IN A BOILER.

(77) A. E. M., Los Angeles, Cal., asks:

1. What is the galvanic action in a boiler? A.—Galvanic action is set up when two different metals are immersed in a dilute acid. In the case of a locomotive boiler, the iron tubes and the copper ferrules on their ends, are the two dissimilar metals and certain kinds of impure water are slightly acid, and a kind of weak electric battery action is produced which eats away the iron tubes near the copper ferrules.

#### PROPORTION OF VALVE AND CYLINDER.

2. What should be the proportion between the valve and cylinder area of a steam engine? A.—The ratio between the cylinder and the valve is not determined by any hard and fast rule. The more important point is the size of the port opening for a cylinder of given dimensions and for given speeds. This has not been determined with any degree of accuracy. It is usual to make the steam port area about one-tenth that of the piston, though less is sufficient for slow speeds. The size of the exhaust port should be determined with a view of securing the free escape of steam and the reduction of back pressure, as far as practicable.

#### PROPORTION OF H. P. AND L. P. CYLINDERS.

3. In a compound, what should be the proportion between the high and the low pressure cylinder? Should it be the

same in a condensing as in a non-condensing engine? A.—The proportion generally adopted for locomotives is in the proportion of 1 to 1½ between high and low pressure cylinders, and of 1 to nearly 3 in Vaucrain compounds. The proportion of 1 to 2½ is often adopted for cross compounds. In marine practice for two cylinder compounds a proportion of 4 to 7 is often used and for three cylinders the ratio generally is 3, 5 and 8. The idea is, as far as possible, to proportion the cylinders so that the total pressure on the pistons shall be as nearly equal as possible.

#### TEST FOR LEAKY GRADUATING VALVE.

(78) C. R. L., Chicago, Ill., writes:

How do you test for a leaky graduating valve 28 in the distributing valve? A.—Charge the brake pipe and the pressure chamber of the distributing valve to standard pressure; then make a 10 lb. service application and place the brake valve handle on lap. Now close the double cock so that the equalizing slide valve exhaust will be open to the atmosphere and watch the brake cylinder air gauge closely. If graduating valve 28 leaks but slightly a gradual increase in brake cylinder pressure will be observed; if it leaks considerably equalizing piston 26 and equalizing valve 31 will move to release position, and application chamber air will be heard escaping at the emergency port of the brake valve. Before making this test it should be known that the rotary in the independent brake valve is tight, also that valve 31 is tight.

2. If the graduating valve 28 leaks, will it release all the brakes on the locomotive? A.—Not unless the engine is a helper or is used in a double header, and the brakes are being operated from another engine. When such is the case, if graduating valve 28 leaked sufficiently to cause equalizing piston 26 to move to release position the brakes would release. But they could be immediately applied again with the independent brake valve. On the engine operating the brakes a leaky graduating valve cannot cause the brakes to release.

3. How should I test for a leaky rotary in the independent brake valve? A.—Make a light independent brake application and leave the handle on lap. Then watch the brake cylinder air gauge. If the independent rotary leaks, the brake cylinder pressure will increase to maximum for which the reducing valve is adjusted.

The Chicago Car Heating Company of Chicago have opened an eastern office at 170 Broadway, New York. Messrs. F. F. Coggin and B. A. Keeler are in charge of this branch.

# Air Brake Department.

CONDUCTED BY J. P. KELLY.

## Eight and One-Half Inch Cross Compound Pump.

The constantly increasing demand for air to supply the needs of the air brake on modern trains, and to operate the various compressed air attachments successfully, has forced to the front the consideration of a larger locomotive air pump. Just at present much interest is manifested by railroad men generally in the performance of the Westinghouse new 8½ in. cross-compound air pump, designed to meet these demands, chiefly because of its ability to furnish a larger quantity of air, at any pressure required, with the consumption of considerably less steam, than any of its predecessors in the air brake field.

In the JUNE RAILWAY AND LOCOMOTIVE ENGINEERING, on page 286, we published the reports of the results of a test made of this pump, working with various steam pressures and pumping air against different main reservoir pressures. These results show in a striking manner the large capacity, the high efficiency and the large steam economy of this cross-compound pump.

The view, Fig. 1, is a half-tone engraving that shows the exterior appearance of the pump, while the diagrammatic drawings, Figs. 2 and 3, show the interior arrangement of ports and valves, and they indicate clearly the distribution of steam through the pump, and how the air is taken in from the atmosphere, compressed and delivered to the main reservoir.

In the design of the cross-compound four cylinders are shown, two of which are for steam and two for air. The steam cylinders are placed above the air, as is the case with the 9½ in. and the 11 in. pumps.

One of the steam cylinders, called the high pressure, is 8½ ins., and the other, called the low pressure, is 14½ ins., in diameter. One of the air cylinders, called the low pressure, is 14½ ins., and the other, called the high pressure, is 9 ins., in diameter. The low pressure air cylinder is located under the high pressure steam cylinder, and the high pressure air cylinder is located under the low pressure steam cylinder.

The reversing valve mechanism is placed in the steam top head. This mechanism consists of two pistons having different areas, connected by a rod, and having a slide valve called the main slide valve, caught between them, which controls the steam ports; and of

a small reversing slide valve, located in a separate chamber, that is operated by a reversing rod. This small reversing slide valve controls the ports leading to and from the chamber behind the larger of the main slide valve pistons. In nearly all respects this reversing gear is the same as that used in the 9½ in. and the 11 in. pumps, except that the slide valve has an extra set of ports to provide for the passage of steam from the high pressure to the low pressure cylinder, and for its exhaust from the latter to the atmosphere. The air cylinders have six air valves, two inlet, two intermediate and two discharge, and each of these valves is in a separate cage, which facilitates removal when worn, and each air inlet valve is provided with an independent air strainer.

There are two piston rods, each having a steam and an air piston head attached.

The rod carrying the low pressure steam piston and the high pressure air piston is solid, and its pistons are termed floating pistons; the other rod is hollow to receive the reversing valve rod. The usual tappet plate is bolted to the high pressure steam piston head to move the reversing valve rod and reversing valve up and down, as in the 9½ in. pump. The stroke of the pistons is 12 ins.

The operation of the pump is as follows: Referring to Fig. 2, the high pressure steam piston is shown, as indicated by the arrows, making its up stroke. Steam from the boiler enters the pump at passage *a* and flows into the top head filling the chambers surrounding both the small reversing slide valve 22, and the main slide valve 72. The position of reversing slide valve 22 is

such that live steam is also free to pass into port *n*, which leads around to the chamber behind the larger main slide valve piston 26, so that the pressures on both sides of this piston may become equal. Hence the smaller main slide valve piston 28, having boiler pressure on one side and atmospheric pressure on the other, is able, under the balanced condition of piston 26, to move

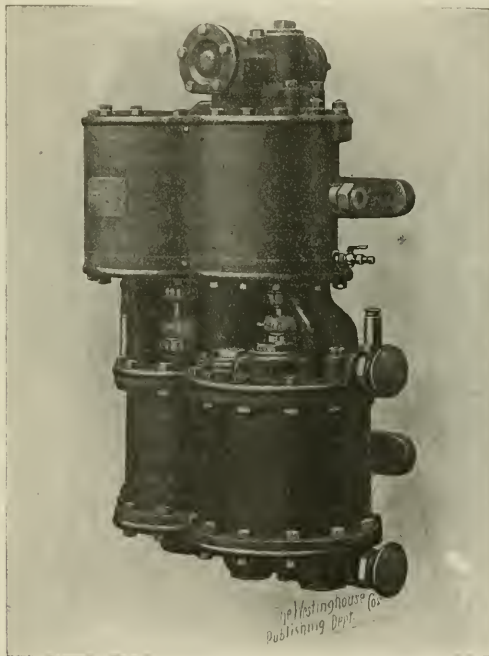

FIG. 1. 8½-INCH CROSS COMPOUND PUMP.

the main slide valve 72 to the position shown, and admit steam through port *k*, in this slide valve, and port and passage *g* in the walls of the high pressure steam cylinder to the lower side of piston 7 and cause it to move in the direction shown.

The steam which had previously been used on the down stroke is indicated by the arrows as flowing through port *c*, in the top head, to ports *h'* and *h*, in the main slide valve, through port *d* in the top head of the low pressure cylinder, to the upper side of the low pressure steam piston 8, causing it to move on its down stroke.

It might be well to remark here that

as one piston goes up the other goes down, and vice versa.

When piston 7 nears the end of its up stroke, tappet plate 18 engages the reversing valve rod 21, and the latter, together with the reversing slide valve

Thus it will be seen that in the steam end of the pump live steam is admitted to the high pressure steam cylinder only; that from this cylinder the steam is exhausted into the low pressure steam cylinder; the latter it is exhausted to the atmosphere; and that as one piston moves up the other moves down.

The air pistons make the same stroke as their respective steam pistons. As air piston 9 (low pressure), Fig. 3, moves upward in the cylinder it forms a vacuum which is filled by the air flowing in through lower inlet valve 38, and the air above this piston is compressed and driven through upper intermediate air valve 39 into the

pressure air piston is making its down stroke air is taken into the low pressure air cylinder at the upper air inlet valve; that the air previously taken into this cylinder at the lower air inlet valve is compressed and driven through the intermediate air valve into the high pressure air cylinder; and that upon the down stroke of the high pressure air piston the air forced into the high pressure air cylinder through the lower intermediate air valve is compressed and driven into the main reservoir; and that this process is repeated on both the up and the down strokes of the pistons.

Because of using the steam expansively, or compounding in two cylinders, a large gain in economy of steam consumption for any given quantity of air compressed is effected.

The maximum pressure against which the low pressure piston works is about 40 lbs., so that having atmospheric pressure on one side of it and about 40 lbs. on the other the difference in pressure is not great; hence ring leakage is cut down to a minimum, and as a consequence, so is the likelihood of pump heating. The same is true of all the

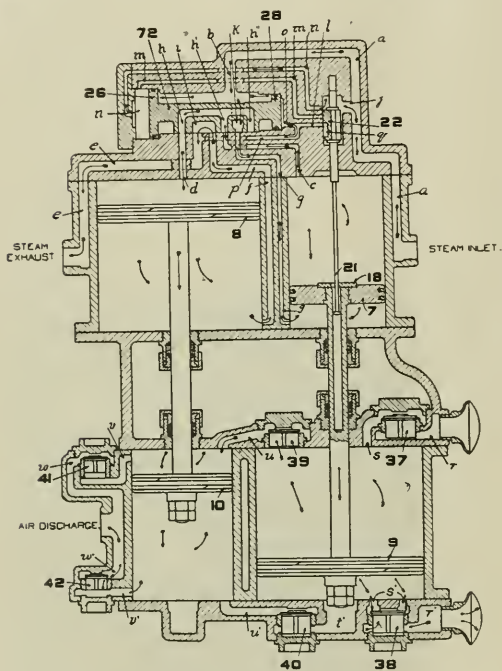

FIG. 2. DIAGRAM OF THE CROSS COMPOUND PUMP UP-STROKE HIGH-PRESSURE-STEAM SIDE.

22, which is attached to this rod, moves upward far enough to close port *n*, and to open port *m*, leading from the chamber behind main valve piston 26 to the atmosphere, and allow steam behind this piston to escape through cavity *q* and passage *l*. The pressure on the other side of piston 26 will then be greater than that on piston 28, and will cause the piston and the main slide valve 10 to move over to the position shown in Fig. 3. Port *d* is now open to the atmosphere through the exhaust cavity *i* in the main slide valve 72, and the steam above low pressure piston 8 can escape to the atmosphere. Port and passage *g* leading to the lower end of the high pressure cylinder is now open through port and passage *h' h'* in the main slide valve 72, and port and passage *f* in the low pressure steam cylinder, so that steam can flow through these ports into the lower end of the low pressure cylinder and cause piston 8 to make its up stroke. Port *k* is now in register with port *c*, and live steam can flow into the high pressure steam cylinder above piston 7 and cause this piston to make its down stroke

upper end of the high pressure air cylinder. Piston 10, descending, compresses the air below it, which was forced into its cylinder by the low pressure air piston on its previous down stroke, and forces it through the lower discharge air valve 42 into the main reservoir. On the reversal of the strokes a similar operation is had and the air in the high pressure air cylinder above piston 10 is forced out through upper air discharge valve 41 to the main reservoir; at the same time the air below the low pressure air piston 9 is being forced through lower intermediate air valve 40 into the lower end of the high pressure air cylinder.

Thus it will be seen that as the low

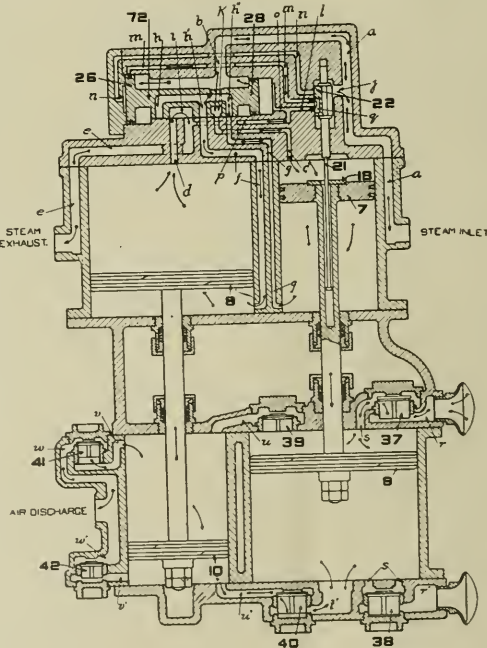

FIG. 3. DIAGRAM OF THE CROSS COMPOUND PUMP DOWN-STROKE, HIGH-PRESSURE-STEAM SIDE.

other cylinders of the pump, both air and steam, and this accounts satisfactorily for the high percentage of efficiency shown by it in all tests to which it has been subject.

The following table shows the com-



parative efficiency of the various locomotive air pumps now in service and

the marked economy secured in steam consumption by the cross compound:

Type of Pump.	Steam Pressure, Pounds.	Constant Main Reservoir Pressure.	Cubic Feet Free Air Per Minute	Steam Consumption per 100 Cubic Feet Free Air.
9 1/2-inch.....	200	130	39	60
11-inch.....	200	130	58	58
Tandem.....	200	130	75	25.50
New York Duplex No. 5.....	200	130	93.56	40.38
8 1/2-inch Cross-Compound.....	200	130	131.04	19.65

**Angle Cock With Handle Lock.**

In the half-tone engravings, Figs. 5 and 6, is illustrated an angle cock handle having a safety lock, which prevents accidental closing of the angle cock.

To turn the handle either from closed to open or from open to closed position, it must first be raised so that the stops on it will clear the lugs on the cock body. The angle cock must be in either the wide open or the entirely closed position before the handle can be put back in place, and when this is done the angle cock is locked. Hence, if the angle cock is open, as shown in Fig. 5, vibrations of the brake pipe, swinging chains, or flying objects cannot change the position of the handle, and cause the cock to close.

The improved handle is an added safeguard against the possibility of a closed angle cock, after brakes are tested and the train is in motion, and it is the type of angle cock handle now being furnished by the Westinghouse Air Brake Company with all air brake equipments sent out from the works. As will be seen, it is a handle that may be easily applied to all the other angle cocks already in service.

**Air Pump Failures Averted.**

By paying strict attention to the care of piston rod packing and its lubrication, and to the lubrication of cylinders—by the way, don't forget to clean the strainers—a very much improved and more satisfactory condition of air pumps will be had. Several pumps that I know of in daily fast passenger service, the

inders and clean strainers. So much can be said in favor of thoroughly lubricating air pumps, thus overcoming heating and cutting of cylinders, and hence reducing the friction. Friction tends to reduce its free and easy movement, thereby creating more wear and tear on every part, and causes that very annoying sound of a pump squeaking and groaning. A free strainer permits of a more free inlet of air to overcome the vacuum in the cylinder created by the movement of the piston. In the event the strainer is plugged, the pump is obliged to work with more or less vacuum in the cylinders, which results in its pounding, and

& Co., of New York, after considerable experimenting on their part, by adapting their Palmetto Packing to the peculiar conditions of throttle valve service. This concern stands ready to send, without charge, samples of their



FIG. 6. ORDINARY AND LOCKING HANDLES.

Palmetto Throttle Packing to demonstrate its merits. Write to them for a sample if you are interested; a postal card will do.

\* The plentiful supply of natural gas at Medicine Hat, affording a cheap and useful fuel, has induced the C. P. R. to

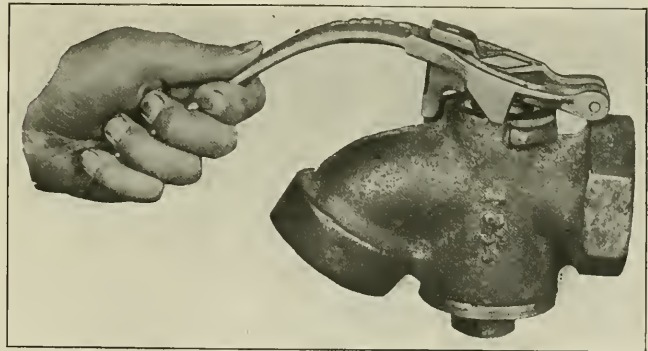

FIG. 4. ANGLE COCK OPEN WITH HANDLE RAISED TO TURN.

this is very detrimental to it. By paying careful attention to the above mentioned details a great amount of the trouble so commonly experienced with an air pump, which is by no means the fault of the pump but rather the faulty care it receives, will be overcome. No doubt it is the experience of a great many air brake men that a pump gives some warning of failure before it completely fails. Therefore, if its little failures and improper actions, which usually consist of inability to compress air, unnatural pounds, and occasionally stopping requiring the steam to be shut off and turned on again, or tapping the heads lightly before it will start, are noted, the pump can be changed before it fails completely, and trouble on the road averted. WIRT D. SEELEY, East Buffalo, N. Y.

decide to erect large repair and construction shops at that place. They will also considerably increase their round-house accommodation and build extensive machine shops. Already the C. P. R. shops are a big factor in the town's growing business, the pay roll at the shops last month being \$37,000.—N. Y. Globe.

**Loitering!**

In England where the vagaries of magisterial decisions on motorists' cases are frequently extremely vexatious, there sometimes enters an element of humor which modifies the exasperation. It was stated in the House of Commons the other day that a man charged with exceeding the speed limit of 20 miles an hour was able to prove to the rural bench of justices that he could not have exceeded 10 miles an hour throughout his journey. Then the rural justices fined him for "loitering."

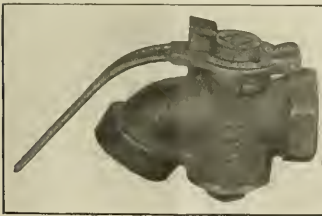

FIG. 5. ANGLE COCK OPEN, HANDLE LOCKED.

piston rod packing, which is of a fibrous kind, remained in good condition for periods of about two months. These pumps receive good attention in the way of maintaining well oiled swabs on the piston rods, thoroughly lubricated cyl-

The difficulty of securing satisfactory packing for locomotive throttle valve stems has been met by Greene, Tweed

### Tunnel Spray Car.

The Central London Railway is one of the deep tunnel lines of the British metropolis. It is called the two-penny (pronounced "tuppenny") tube, and extends from the Bank to Shepherd's Bush. The up and the down line runs each in a separate tunnel of circular form, and the whitewashing of the interior of these tubes is done in a very ingenious and expeditious way. Mr. E. P. Grove, the chief engineer of the company, is responsible for the third-rail, the track rail bonding and the lighting, while the tunnels themselves and the permanent way are in charge of the way and works engineer.

In order to secure better results in the matter of tunnel lighting, Mr. Grove determined to cover the interior of both the tubes with whitewash, and as the hours in which such work can best be done are from 1.20 A. M. to 4.20 A. M. on weekdays, or until 7.20 on Sundays, he decided to get up a machine for the purpose, and his attention was directed to an apparatus for washing hops which was in regular use in the

it throws over and under a bush, called the "mistifier," and its application to the two-penny tube no doubt mystified the travelers one morning when they found themselves riding through enclosing walls of snowy whiteness.

The machine consists essentially of a pump, a tank and a movable head, from which come off a number of jets fixed at the end of short rubber hose pipes and which are each clamped in the required position. The road wheels of a hop washer were removed and the tank with its pump inside was placed at the end of a car which was equipped with a shaft for working the pump, driven by a 6 h.-p. shunt-wound motor. The whitewash is mixed in a large tank which forms part of the water softening plant of the road, so that the lime instead of encrusting the outside of the

for sanitary and light reflecting purposes.

Inside the motor car which is one of the experimental multiple unit equipment originally used by the company, a large tank holding about 1,200 imper-



READY FOR BUSINESS IN THE TWO-PENNY TUBE.

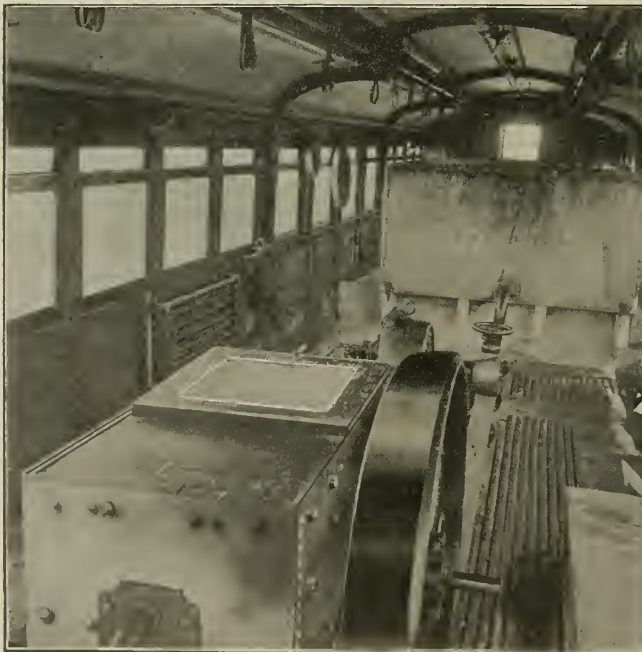

INTERIOR OF WHITEWASHING CAR, CENTRAL LONDON RAILWAY.

hop fields of Kent. These machines are said to be efficient hop washers, for all systems of polling or stringing and under all conditions of growth, and so Mr. Grove thought the plan was applicable to railway use. This hop machine is, on account of the misty spray which

boiler tubes at the power station is used to coat the inside of the tubes through which the traffic is carried. Thus we see that the economy produced by the use of a water softening plant is still further increased by the use of the principal by-products of the operation

ial gallons of whitewash was placed. This tank was connected with the small tank containing the pump, which was part of the makeup of the hop mystifier. The pump working inside this smaller tank has the effect of keeping the whitewash well churned up and mixed, as the cranks and pump rods are all immersed in the liquid. The moveable head with the nozzles on the original machine was fixed at the end of the car and more nozzles were added, making 40 in all. A pressure of 90 lbs. per square inch is maintained by the pump and with this pressure there is no tendency for the jets to clog or choke if the whitewash has been properly prepared. The whole machine, having jets distributed all round, is in operation, like a setpiece in a fireworks display, or, one might say, like a huge Catherine wheel with several vents, stuck so that it cannot revolve. It might be useful as a fire quencher some day. The pair of planks joined together at right angles and extending out in front, covers the third rail and prevents the whiewash getting on it when the rest of the interior is being drenched with the 40 separate jets all playing on the tunnel casing rings.

When the car is in service its speed is regulated by means of resistance coils and by putting the motors in series. It is thus moved at about two miles an hour, and at this rate three-quarters of a mile is usually done in 45 minutes, with the expenditure of about 850 gallons of whitewash while going twice over that distance. Previous to the whitewashing trip, the car is run through the tunnel, the pumps forcing clean water out of the jets. This is for the purpose of washing down all the dust and dirt which may have accumulated. The new whitewash is, therefore, splashed on to the walls of a comparatively clean

tunnel, and the result is that the tubes are made thoroughly sweet and clean.

In practice the car comes back to the charging station two or three times in a night where the large tank on the car is quickly and easily charged, as the water softening plant is close to the track. About two miles of tunnel tube is washed down and sprayed twice with whitewash in one night's work. The chief engineer regards the performance of the tunnel sprayer as very satisfactory, though he admits that the finish is not quite as good as could be got with hand work, but it is much faster, and, from a sanitary point of view, it has practically the same effect. The labor is, of course, considerably less than if done by hand.

Mr. Groves, to whom we are indebted for the photographs and the data concerning the work of the whitewashers, intends to secure even more perfect work by arranging the nozzles on a rocking frame which will have a radial movement of about 18 ins. This will probably distribute the whitewash more evenly over the interior of the tunnel. In any case, the two-penny tube travelers are pretty sure of bright, clean surroundings and plenty of light as they are carried along to and from business in London's deep tube "white way."

#### Case Hardening and Potashing.

Case hardening, or the method of having soft iron coated with hard steel, requires more skill than is generally attributed to the proper manipulation of the process in order to obtain the best results. It is a very important advantage in machine construction that the work of machining and fitting can be done on soft metal and then the parts hardened to a sufficient depth, combining in a very high degree the elements of durability and elasticity.

The common method is to have the articles packed in boxes which in many instances are too large. It is noteworthy that the thinner the boxes are the more equal will the absorption of the carbon take place. Malleable cast iron boxes are the best, and the packing may be bone or leather cuttings, hoofs or horns. These may be used raw or after conversion into charcoal. A layer of the material should be placed in the bottom of the box, then a number of the articles to be case hardened should be laid sufficiently far apart from each other so that there can be no possibility of contact. Powdered potassium cyanide or prussiate of potash in the form of dust should be shaken over the articles during the process. The packing should be thoroughly dry. The parts of the articles that are desired to remain soft should be covered with fire clay or pipe clay mixed with white ash from the boxes. Only the parts to

be hardened should be in contact with the carbonizing material, and if this is carefully attended to, the results will be satisfactory. It is well in all cases to have the covers of the boxes pierced with small holes for the insertion of testing wires to show the degree of heat and consequent penetration of the carbon.

In the oven the heat should be maintained at a steady temperature of about 1,700 degrees. This will heat the articles to a bright cherry red. This should continue from ten to twelve hours. The time occupied in the heat-

hardening mixture out of chemicals is often used where horns, hoofs and bones are not to be had in sufficient quantities. The mixture consists of sixteen parts of lamp black, eighteen parts of sal soda, four parts muriate of soda, and one part of manganese.

It may be added that potashing is sometimes conveniently used in surface hardening. The operation consists of heating the article to be treated to a bright red, being careful not to let it scale from excessive heat. Then cover the heated surface with the prussiate of potash, which will readily fuse

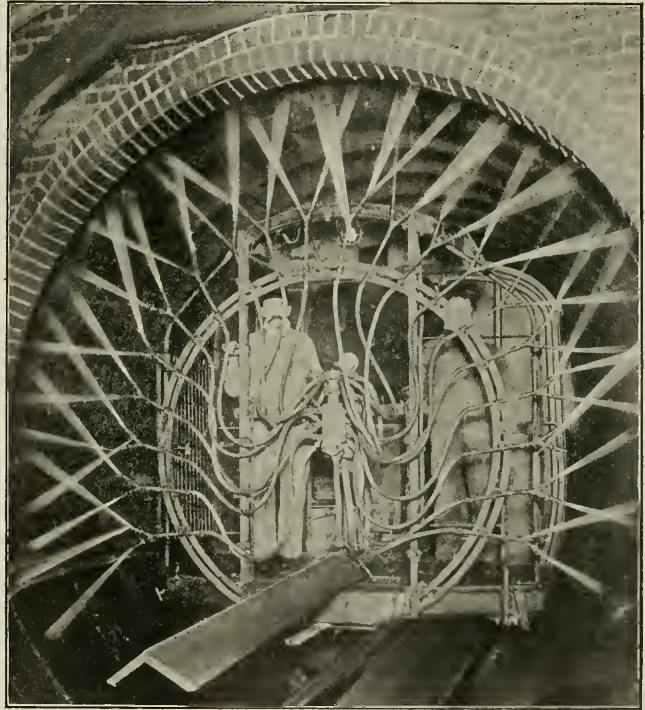

CLEANING AND WHITEWASHING CAR ON THE CENTRAL LONDON RAILWAY.

ing process is an important factor in the operation, the longer period for the duration of heat deepening the thickness of the eventually hardened surface. It is good practice to withdraw a wire from time to time, and after cooling the wire it can readily be broken by a hammer, when the depth of hardening can readily be seen.

The cooling process should be done as rapidly as possible. Running water is the best for cooling, but as that cannot always conveniently be had, solutions of salt, cyanide and other chemicals may be used to increase the coldness of the water. The hardening should penetrate at least one-sixteenth of an inch. A formula for making case

and spread over the heated metal, which should be again placed in the fire to completely fuse the solution, after which the article is dipped in cold water. The cooling should be as rapid and equable as possible, to prevent warping, which, in the case of curved or thin articles, is sometimes unavoidable, but can be guarded against by careful handling of the articles at the moment of contact with the water.

Methods of raising water by the pressure of air were described in Hero's book, called "Pneumatica," written about 200 years before the beginning of our era.

### Smokeless Train Shed.

The new passenger train shed of the Delaware, Lackawanna & Western at Hoboken, N. J., may fairly be called a unique structure, and Mr. Lincoln Bush, chief engineer of the road, instituted a new departure in the construction of passenger terminals when he designed the smokeless train shed for the dustless road of anthracite.

The extent of ground covered by the shed is about four acres, and the weight of the columns and roof is such that if evenly distributed over this area there would be about 19 lbs. on every square foot of surface. The significance of this fact becomes apparent when the weight of the next lightest train shed among those recently constructed and generally considered as modern and standard types in this country is about 24 lbs. per square foot. Mr. Bush's train shed is a series of flat arches supported by rows of cast iron columns, while most of the other sheds are lofty steel arch structures, 75 ft. or more in height, to get the steel work as far removed as possible from the direct effect of engine gases, and with an architectural effect that is questionable.

The shed consists of six flat arches, 43 ft. 4½ ins. span, made of plate edged with angle iron and flanked by two similar arches having a span of 35 ft. 10

ins. The passenger platforms are made of concrete and from them rise the columns which carry the roof. These pillars are made of cast iron, circular in form, 9 ft. 3 ins. high up to the capital,

These purlins are completely enveloped in concrete and this material is carried down so as to go slightly below the top of the smoke stack of the standard passenger engine, and it is

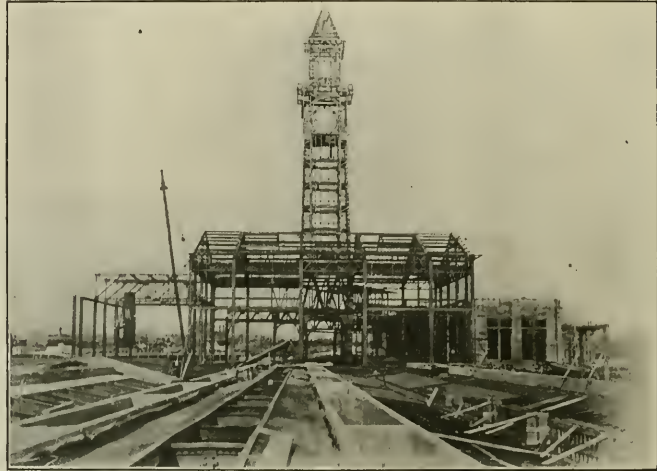

MAIN BUILDING, LACKAWANNA STATION, HOBOKEN, N. J.

which is modeled after the Roman-Ionic form in which the four volutes are placed radially and the egg and dart moulding shows between. The columns continued above the capitals are square in section and to these are bolted the roof trusses across the tracks and also the ends of the steel trusses which run parallel to the platforms. The height of the roof above the platform measured at the pillars is 14 ft. 3 ins., and the roof has a pitch of 2½ ins. to the foot, so that the maximum clear height of the arch above rail level is 16 ft. 10½ ins.

The feature of the shed which attracts most attention is the method of getting rid of smoke and gas. As a matter of fact, the shed does not so much provide means for getting smoke and steam out of the shed as it does for preventing smoke and steam ever getting into the shed. In the roof and exactly over the center of each track there is a smoke duct the whole length of the shed, the walls of which are carried down so that the top of most of the Lackawanna smoke stacks just enter the duct. The smoke ducts are simply long parallel slots in the roof 2½ ft. wide, something like the slot cut in the roof of an observatory to leave the line of sight for a telescope open and unobstructed.

The construction of the smoke ducts is interesting. The walls of each duct are, in fact, light steel trusses made of angle iron and filled in with expanded metal. These run from roof truss to roof truss, over the track, and form what are called the smoke duct purlins.

also carried up about one foot above the level of the top of the roof. The concrete makes two solid parallel walls capable of resisting the action of the smoke laden exhaust from the engines as they pass in and out, and prevents the action of the engine gases on the steel framework encased in the concrete.

At the points where the roof girders cross the open smoke duct, the plate



SMOKE STACK BELOW SMOKE DUCT.

truss is itself enveloped in concrete and its under side is further protected by a V-shaped cast iron trough with the sharp edge down so as to split the exhaust when it comes under the line of the roof truss and throw the exhaust out in the direction of the longitudinal axis of the smoke duct, instead of throwing it in a lateral direction into the train shed. The cast iron trough is filled in with concrete so that in the whole length



STEEL TRAIN SHED UNDER CONSTRUCTION.

ins. and 30 ft. 4½ ins., respectively. The six large spans have each two tracks beneath them and the flanking spans one track each. There are thus 14 tracks under cover.

of the smoke duct the only metal surface exposed to the action of the smoke gases and the steam is the beveled underside of the cast iron deflector. The V-deflector, although directly below and shielding the roof truss lower flange, is carried on a pair of angle irons attach-

a coin-in-the-slot machine. At the angle where the roof slopes down from the walls of the smoke duct, there is necessarily a sort of pocket formed where, if by any chance, smoke, steam or heat got into the train shed, would lodge. To avoid even this somewhat remote

roof and the natural position of the gutters is over the line of pillars, and the slope of the troughs leads the water to the top of the pillars and the waste pipes pass down inside of each pillar and reach the underground drainage system without being seen, or, as is often the case, placed where they are easily broken or damaged by passing baggage trucks or mail wagons. This drain pipe is made of wrought steel, and telescopes inside of the cast iron pillars, there being an air chamber or space of 1½ ins. between the outside of the drain pipe and the inside of the cast iron pillar.

The shed altogether presents evidence of very thoughtful and careful design, in which actualities in railway terminal operation have been appreciated and provided for. The cost of construction has been comparatively light because the parts are easily made and are duplicates. The cost of erection has been small because no false work has been necessary and it has only been necessary to preempt two tracks at any one time and to employ the company's wrecking crane, which is available for such work. It will be seen that with this type of construction the interference with the handling of traffic during construction is reduced to a minimum, which is a very important consideration at a main terminal. The substantial reduction in the amount of material used in this shed when compared with other styles, and the elimination of the large maintenance charges for painting and renewals of steelwork, skylights, etc., are some of the advantages of this type of train

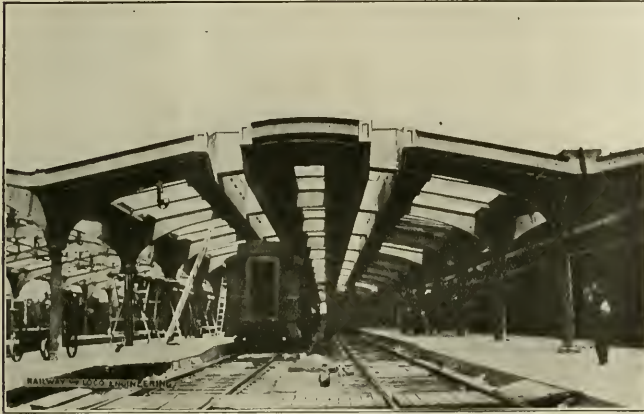

LACKAWANNA TRAIN SHED WITH CONCRETE SMOKE DUCTS.

ed to the smoke duct purlins. This arrangement was made so as to secure a convenient attachment for the cast iron V-deflector, and should it be necessary at any time to replace the deflector, very little of the concrete smoke duct would have to be disturbed, while had the connection been made to the steel rib of the roof truss it is evident that much more of the concrete would have to be removed. As a matter of fact, the deflector being of cast iron will not be as readily affected by the engine gases, as would have been the case if made of steel or wrought iron, and the connection for this deflector has been so made that it can readily be removed if necessary. If this deflector became eaten up by the effects of engine exhaust, it would be a comparatively easy matter to connect another trough of similar shape underneath it. Furthermore, there is for protection between the cast iron deflector and the bottom of the steel arch flange a quantity of reinforced concrete which has a thickness of about 4 ins. immediately under the center of the roof rib, and the V-shaped deflector is simply an additional covering and protection from the blast effect of engine exhaust.

The walls of the smoke duct are vertical and are carried sufficiently far above the roof outside, and sufficiently far below the roof inside, to prevent the side drive or drift of a storm from reaching the platforms, and it is as impossible for rain or sleet to get directly at the area where passengers stand as it would be impossible to give side motion to a nickel when dropped in the opening of

possibility, and to maintain ventilation in all parts of the shed close to the under side of roof, the concrete walls of the smoke duct are pierced by a number of small oblong holes which produce a light though constant current of air from the space under the roof to the smoke duct. These air passages have a slight droop or fall from inside to outside so that moisture, if there is any, will easily pass through and

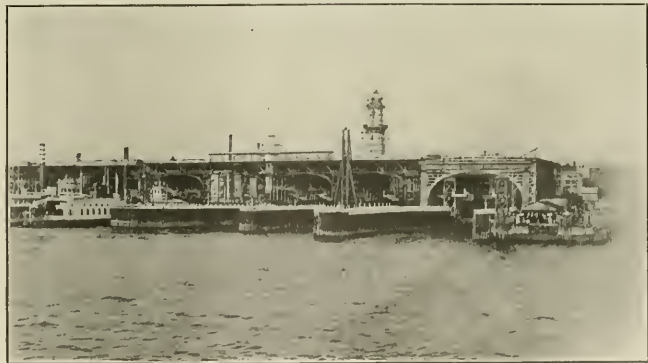

LACKAWANNA FERRY SLIPS, HOBOKEN, N. J.

any drip from rain or storm will be on the inside face of the smoke duct, and not on the sides toward the platforms.

Another neatly executed detail in the design of this shed is the drainage system for taking off snow and rainwater from the roof. The lowest part of the

shed. It is a very noticeable fact that none of the annoying echoes found in the ordinary high vaulted train sheds are present in this new type of shed. Lastly, there is the comfort to those who patronize this road. Sunlight from above is not filtered through glass

dimmed by dirt and grime, or through an atmosphere clouded by smoke and steam as in high vaulted roof sheds. The Lackawanna terminal has in the roof immediately above the platforms a string of amply proportioned skylights, and close enough for washing to be within reach of the car cleaner's brush. A row of skylights with ventilated ridge down the center line of each bay of the shed throws lights between the tracks, and when the shed is filled with trains this light reaches the inner lines of car windows remote from the platforms. The Lackawanna train shed is a saver of outlay and cost of maintenance to the company, and a comfort giver and a gratification to the traveling public.

#### High Side, Steel Hopper Car.

The Lehigh Valley Railroad, of which Mr. F. N. Hibbits is mechanical superintendent, recently purchased

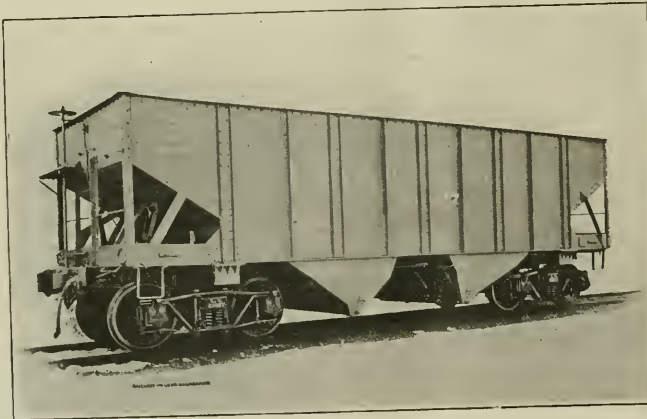

HIGH SIDE STEEL HOPPER GONDOLA FOR THE LEHIGH VALLEY.

from the Pressed Steel Car Company, of Pittsburgh, some cars which may be termed high side steel hopper coal cars. These cars are, as far as internal contour is concerned, like the letter W, the two lower angles being the discharging points.

The cars are of 100,000 lbs. capacity, while the tare weight goes a little above 39,000 lbs., making a ratio of paying load to dead weight in the neighborhood of 1 to 2.56.

The body and the floor of these cars is formed of  $\frac{1}{4}$  in. plates riveted to  $3\frac{1}{2} \times 3\frac{1}{2} \times \frac{1}{2}$  in. angles extending around the top and bottom and the floor of the car. The side plate of the body forms the side sill except at the end of the car, where it is reinforced with a light 8 in. channel extending from the bolster body to the end. Between the body bolsters the side plate extends below the floor of the car and is reinforced by angle iron.

The side stakes are alternate channels and angles, the channels being 7 in., weighing 9.75 lbs. to the foot, and the angles  $3 \times 3 \times \frac{1}{4}$  in. The bolsters are of the Bettendorf 10 in. continuous I-beam type, riveted to the car, and thus forming an integral part of it. The trucks are of the arch bar type with Bettendorf truck bolster and steel center plate. The wheel base is 5 ft. 4 ins., the wheels each weigh 700 lbs., and are 33 in. cast iron chilled. The axles have  $5\frac{1}{2} \times 10$  in. journals. The cars are equipped with the Westinghouse air brake and steel back brake shoes of the Christie type.

The center sills are 15 in. channels 33 lbs. to the foot. The section is arranged with flanges turned to the center of the car and securely riveted to the draw sills with  $\frac{7}{8}$  in. rivets. The draft sills are the Bettendorf cast steel type, designed to take twin spring draw gear with standard M. C. B. helical springs

#### Good Work of Lathe and Saw.

Our illustrations of work done by a pair of tools in the shops of the Central Railroad of New Jersey are very inter-



CHIP FROM CROSSHEAD PIN.

esting, and we are indebted to Mr. Wm. McIntosh, superintendent of motive power of the road, for the samples and also for a copy of the letter from the shop superintendent at Elizabethport, N. J., which explains the operations. Writing to the S. M. P., Mr. Van Doren says:

"I am sending you a chip that was made while cutting off a crosshead pin on our 6 $\frac{1}{4}$  in. Spindle Gisholt lathe, which is quite a novelty.

"I also send you a thin section that was cut from the knuckle joint of one of our side rods, which shows what can be done with our Taylor-Newbold saw. You will see that the chip is uniform in thickness, which shows that the saw, in cutting so near to the edge of the solid piece of metal, will not crowd very far from a straight line, which makes it possible for us to saw out these knuckle

$6\frac{1}{4} \times 8$  ins. and cast steel coupler with 5x7 in. shank. The end sills are made of 10 in. channels with a pressed steel sub end sill 10 $\frac{3}{4}$  ins. deep. The end braces and floor stiffeners are  $3\frac{1}{2} \times 3\frac{1}{2} \times \frac{1}{2}$  in. angles.

Some of the dimensions are as follows:

Cubic contents, level with top.....	1,799 cu. ft.
Length, inside of body.....	30 ft.
Length, over sub end sills.....	31 ft. 6 ins.
Length, center to center of trucks at ft.	9 ins.
Length, drop door in clear.....	3 ft. 4 ins.
Width, inside of body.....	9 ft. 5 $\frac{1}{2}$ ins.
Width, over side stakes.....	10 ft.
Width, drop door in clear.....	2 ft. 3 $\frac{1}{4}$ ins.
Height from rail to body top.....	10 ft.
Height from rail to coupler center	2 ft. 10 $\frac{1}{2}$ ins.

Men employed in the workshops of the two principal Scotch railways who acquire special proficiency in ambulance work are rewarded by an annual free family pass for any part of the system.



SECTION FROM END OF SIDE ROD NO THICKER THAN CARDBOARD.

joints without placing them on the slotter, as was necessary before using this style of saw."

# Of Personal Interest.

Mr. T. H. Bacon has been appointed assistant chief engineer of the Chicago Great Western Railway.

Mr. G. S. Davis has been appointed chief engineer of the Parral & Duraugo, with office at Mesa de Sandia, Mex.

Mr. C. W. Van Buren has been appointed divisional car foreman of the Canadian Pacific at Montreal, Can.

Mr. W. F. Hannes has been appointed consulting engineer of the Coahuila & Zacalecas, vice Mr. H. Scholfield, resigned.

Mr. William S. Gray has been appointed general foreman of the Central Covington shops of the Louisville & Nashville Railroad.

Mr. V. F. DeVinny has been appointed acting purchasing agent of the Chicago Great Western Railway, vice Mr. A. D. Ward, resigned.

Mr. Webb C. Ball has been appointed general time inspector of the Missouri, Kansas & Texas Railway, with headquarters at Dallas, Tex.

Mr. M. S. Curley has been appointed superintendent of motive power of the Sierra Railway of California, with headquarters at Jamestown, Cal.

Mr. B. A. Scofield has been appointed trainmaster and road foreman of engines of the Peoria division of the Vandalia, vice Mr. O. E. Raidy, resigned.

Mr. N. H. Allfree, for some time past chief draftsman for the Locomotive Appliance Co., of Chicago, has been appointed mechanical engineer of that company.

Mr. A. L. Tripp has been appointed supervisor of water service of the Cleveland, Cincinnati, Chicago & St. Louis at Indianapolis, vice Mr. F. W. Smith, transferred.

Mr. George W. Cooper, who has been acting as master mechanic of the Monterey division of the Mexican Central Railroad for several years, has resigned from that position.

Mr. D. C. Courtney has been appointed superintendent of motive power of the Coal & Coke Railway, with headquarters at Elkins, W. Va., vice Mr. C. E. Turner, resigned.

Mr. J. H. Farmer has been appointed master mechanic of the Mexico division of the Chicago, Rock Island & Gulf, with office at Dalhart, Tex., vice Mr. E. D. Andrews, resigned.

Mr. F. J. Kraemer, of Burlington, Iowa, has been appointed master mechanic of the St. Louis, Iron Mountain & Southern at Baring Cross, Ark., vice Mr. C. A. Braun, resigned.

Mr. J. J. Bartholomew has been appointed air brake inspector for the entire Cotton Belt system, and will have charge of a plant to be established at Tyler, Tex.

Mr. C. E. Roach, erecting foreman in the Horton shops of the Rock Island, has been appointed roundhouse foreman for the Denver & Rio Grande at Salt Lake City.

Mr. W. H. Chadbourn has been appointed chief engineer of the Chicago Great Western Railway, vice Mr. A. Munster, resigned; with office at St. Paul, Minn.

Mr. C. L. Bundy, general foreman of the Lackawanna shops at Scranton, has resigned to become manager of the car department of the Hicks Locomotive Car Shops at Chicago.

Mr. G. M. Reynolds has been appointed master mechanic of the Alliance division of the Chicago, Burlington & Quincy, with headquarters at Alliance, Neb., vice Mr. E. W. Fitt, transferred.

Mr. Louis Kries, formerly general foreman at Dover, on the Delaware, Lackawanna & Western, has been appointed general foreman of the car shops at Keyser Valley, vice Mr. Bundy, resigned.

Mr. J. Bertram Young has been appointed chemist of the Philadelphia & Reading Railway, vice Mr. Robert Job, resigned. He will report direct to the superintendent of motive power and rolling equipment.

Mr. Geo. Thompson, master mechanic of the Union Pacific at Omaha, Neb., has been transferred to Pullman, Col., in a similar capacity, vice Mr. J. A. Turtle, who takes Mr. Thompson's place at Omaha.

Mr. Andrew M. McGill, general foreman of the New York, New Haven & Hartford shops at New Haven, has been appointed master mechanic on the Lehigh Valley. On his departure the shop staff and employees presented him with a handsome gold watch and chain.

Mr. E. D. Andrews, master mechanic at Dalhart, Tex., has been appointed to the new office of master mechanic of the Arkansas division, extending from Booneville to Memphis, and of the Louisiana divisions of the Chicago, Rock Island & Pacific, with office at Little Rock, Ark.

Mr. LeGrand Parish, heretofore assistant superintendent of motive power of the Lake Shore & Michigan Southern, has been appointed superintendent of motive power and equipment of the

Michigan Central, with headquarters at Detroit, Mich., vice Mr. E. D. Bronner, transferred.

Mr. Frank Huffsmith having resigned as superintendent of motive power and rolling stock of the International & Great Northern, the position he held has been abolished. Mr. George S. Hunter has been appointed general master mechanic in charge of the locomotive and car department, with headquarters at Palestine, Tex.

Mr. E. W. T. Gray, who has for years been manager of the New York sales office of the Westinghouse Electric & Mfg. Company, resigned recently to take up commercial work in another field. Mr. Gray's decision to sever his connection with the Westinghouse Company was received with great regret by the management, he having been one of the pioneer employees of the company.

Mr. Thomas Fildes, formerly assistant superintendent of motive power of the Long Island Railroad and of the New York & Rockaway Beach Railway, has resigned. He has been connected with these roads for the past seven years, and has achieved the reputation of being a careful and efficient officer. Any company engaging Mr. Fildes will secure the services of a thoroughly competent man.

Mr. C. L. Hempel was recently elected president of the International Railway Master Boiler Makers' Association, Mr. E. J. Hennessy was elected first vice-president, Mr. A. L. Lucas second vice-president, Mr. T. J. Smallwood fourth vice-president, and Mr. J. T. Goodwin secretary-treasurer. The executive committee, as well as being composed of the above-mentioned officers of the association, consists of Messrs. George Wagstaff, John McKeown, G. W. Bennett, W. H. Shaw and A. E. Brown.

The officers recently elected for the Newton Machine Tool Works, Inc., of Philadelphia, are: Messrs. Harry W. Champion, president; William M. Graham, treasurer; Ellis J. Hannum, secretary. The election of new officers is occasioned by the death of Mr. Charles C. Newton, founder and president of the company, with whom the above named gentlemen have been closely associated in executive positions for many years. No changes in the conduct of the business will be made.

Mr. W. C. Webster, who succeeds Mr. Gray as manager of the New York sales office of the Westinghouse Electric & Mfg. Co., has a broad general

knowledge of the company's commercial policy, and on account of his close association with the sales department in the past, enjoys a personal acquaintance with the entire sales force, which should be of great advantage to him in his new work. Mr. Webster entered the employ of the company in 1893, and has always been identified with the sales department.

Mr. H. F. Ball has resigned as superintendent of motive power of the Lake Shore & Michigan Southern to accept a position with the American Locomotive Company as vice-president in charge of their automobile department. Mr. Ball began his railroad career with the Pennsylvania Railroad, remaining with the company for six years, four of which were spent in the shops learning the trade and two in the drawing office. After leaving the Pennsylvania Railroad he accepted a position as chief draftsman of the car depart-

ment of that road until 1890, when he entered college. After graduating in 1894 he took a position in the maintenance of way department of the Southern Railway, where he remained for four years. In 1898 he was appointed supervisor on the New York Central & Hudson River, and later was made division engineer of the eastern division until September, 1899, when he was appointed engineer of track. He became engineer of maintenance of way of the New York Central in February, 1903, and in July, 1905, was appointed assistant to the general manager, from which position he has now been promoted to that of assistant general manager.

Mr. E. D. Bronner, superintendent of motive power and equipment of the Michigan Central, has been appointed superintendent of motive power of the Lake Shore & Michigan Southern, the Lake Erie & Western and the Chicago, Indiana & Southern, with headquarters

at Cleveland, O., vice Mr. H. F. Ball, resigned. Mr. Bronner has been prominent in that class of younger men who have of late years been rapidly coming to the front, and has been unusually successful in the development of the department under his charge. He has been a close student of the development of modern railroading, and the high efficiency of the mechanical equipment of the M. C. R. R. is the result of his executive ability and foresight. Since 1889 he has been an active member of the Master Car Builders' Association, and during that time has served on various important committees. He has held the office of vice-president, has been a member of the executive committee and is at present one of the members of the arbitration committee. It will be remembered that out of deference to tradition he refused to accept nomination as president in 1890, because his jurisdiction as a mechanical department officer extended not solely over the car department, but over the locomotive department as well. Since 1893 he has also been a member of the Master Mechanics' Association. Mr. Bronner was born February 19, 1859, at Buffalo, and is a graduate of the U. S. Naval Academy at Annapolis. He entered the employ of the Canada Southern Railway as draftsman at St. Thomas in 1880, and was transferred from that point as draftsman in car shop at West Detroit in February, 1883. On April 12, 1886, he was promoted to the position of general foreman of the car department, and in February, 1890, he was appointed master car builder. May 6, 1896, he became assistant superintendent of motive power and equipment, and less than four years afterwards, February 1, 1900, he was appointed superintendent of motive power and equip-

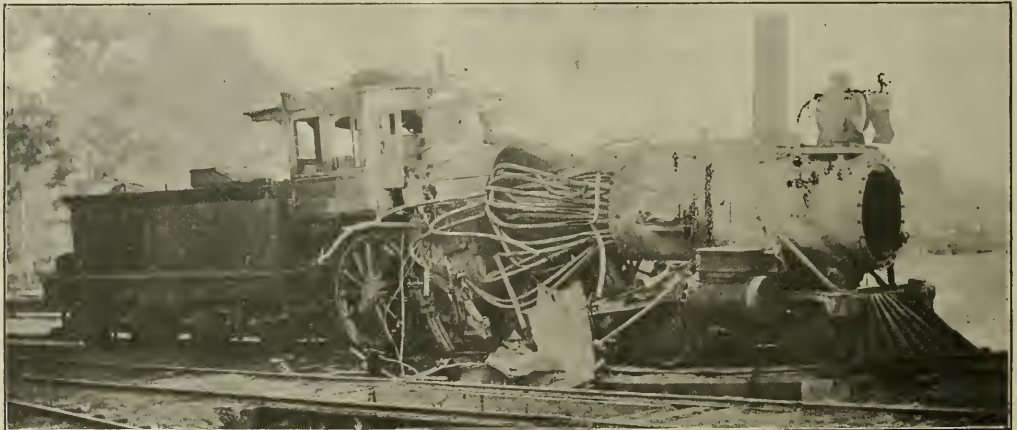

RESULT OF BOILER EXPLOSION. SHEET GAVE WAY AT SEAM.

(For description see page 388.)

(Courtesy of Scientific American.)

ment of the Lake Shore & Michigan Southern, from which position, through various promotions, he rose to that of superintendent of motive power. He remained with the Lake Shore sixteen years, and was still holding that position at the time of his election as vice-president of the automobile department. Mr. Ball's headquarters are in New York.

Mr. A. T. Hardin, whose promotion to the position of assistant general manager of the New York Central & Hudson River, with headquarters at New York, has already been announced, was born in 1868, and graduated from the University of South Carolina in 1894 with the degree of C. E. He entered railway service in 1882 as telegraph operator on the Richmond & Danville, and subsequently became agent and stenographer in the service

at Cleveland, O., vice Mr. H. F. Ball, resigned. Mr. Bronner has been prominent in that class of younger men who have of late years been rapidly coming to the front, and has been unusually successful in the development of the department under his charge. He has been a close student of the development of modern railroading, and the high efficiency of the mechanical equipment of the M. C. R. R. is the result of his executive ability and foresight. Since 1889 he has been an active member of the Master Car Builders' Association, and during that time has served on various important committees. He has held the office of vice-president, has been a member of the executive committee and is at present one of the members of the arbitration committee. It will be remembered that out of deference to tradition he refused to accept nomina-

tion, which position he has held until his recent appointment to the Lake Shore.

#### Obituary.

We regret to have to announce that Edgar Shellabarger, master mechanic of the East Broad Top Railroad, died at his home in Orbisonia, Pa., on the night of July 12, at the age of 68. He was a native of Pennsylvania, and served with distinction in the Civil War. Learning the machinist's trade in the old Pennsylvania shops at Paterson, Pa., he spent many years in the service of that company at that point and Altoona, and several years with the Baldwin Locomotive Works in Philadelphia, prior to the time he became an employee of the East Broad Top Railroad, in 1882. Since that time



he has successively filled the positions of machine shop foreman, general foreman, and master mechanic, with supervision over the machinery of the Rockhill Furnace Co. and the Rockhill Iron and Coal Co., in addition to that of the railroad.

Western railroad men of the old school will hear with deep regret of the death of Mr. C. J. Ives, for many years president of the Burlington, Cedar Rapids & Northern, before its absorption by the Rock Island Railway. Mr. Ives was a native of Vermont, where he was born in 1831, and at the age of 16 moved to Iowa with his parents and engaged in agricultural work. In 1861 he became connected with the Burlington & Missouri Road, and from the position of freight clerk he gradually worked his way upwards. In 1871 he was appointed general passenger and freight agent and from 1875 to 1884 he was general superintendent of the road and af-

loyal. His heart was warm. He was of marked ability, a pioneer in western railroading and an honor to the community among which he lived.

**Union Pacific, Atlantic.**

The Union Pacific is one of the group of railroads made up of the Southern Pacific, the Oregon Short Line, the Leavenworth, Kansas & Western, the Oregon Railroad and Navigation Company, and the Chicago & Alton, known as the Associated Lines. The Union Pacific have recently obtained from the Baldwin Locomotive Works some 4-4-2 engines of the 4-cylinder balanced type for fast passenger service. One of these interesting engines was exhibited at the Master Mechanics' convention at Atlantic City this year. The design conforms as far as possible in detail to the common standards adopted by the Associated Lines.

The engine is built with cylinders 16 and 27x28 ins. The high pressure cyl-

diameter, placed above the low pressure cylinders, but with centers each set in 5 ins. closer to the smoke box than

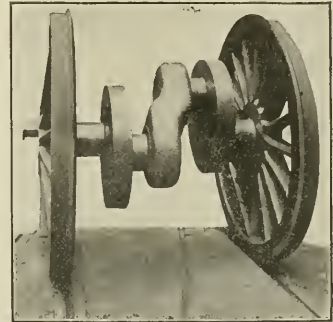

MAIN DRIVERS, WITH CRANK AXLE.

those of the cylinders. The valve gear is the Walschaerts motion, actuated by cranks on the main drivers.

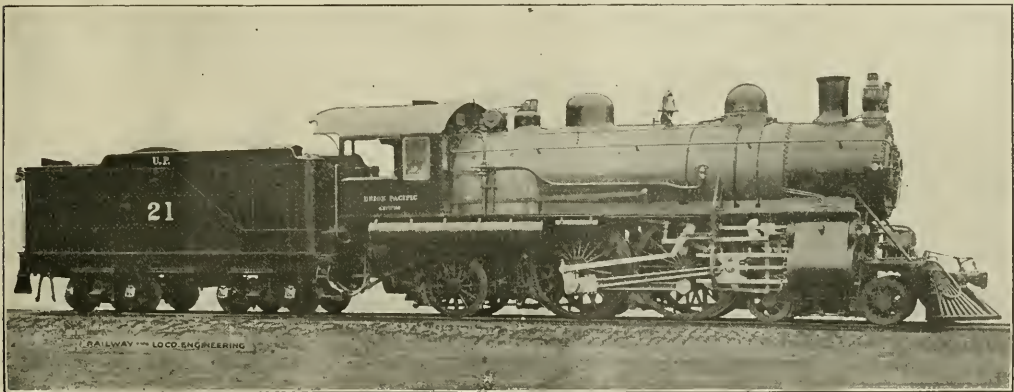

FAST PASSENGER 4-4-2 FOR THE UNION PACIFIC.

Baldwin Locomotive Works, Builders.

W. R. McKeen, Jr., Supt. of M. P. and Machinery.

ter that date he was made president of the road. His advancement was steady and continuous, and the growth of the road with which he was so long connected was largely accomplished through his efforts. As an illustration of the growth of the railroad, it may be stated that when Mr. Ives began work on the road its western terminus was at Ottumwa, and it was then forty miles in length. At his retirement the aggregate length was 1,350 miles. Although a shrewd business man, Mr. Ives had a warm and kindly heart. He would not tolerate the discharging of old employees simply to make room for others. There are hundreds of people in Cedar Rapids who have occasion to remember Mr. Ives' liberality. His long and successful career did not bring to him either swelling of the head or contraction of the heart. His friendship was

inders are inside and the low pressure are outside. The crossheads are of the

All the pistons drive on the rear pair, the low pressure are connected to crank

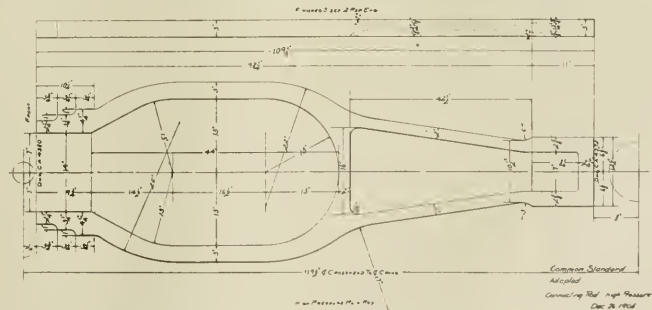

HIGH PRESSURE CONNECTING ROD, SURROUNDING LEADING AXLE.

alligator type, while the inside ones each run in four guide bars. The main valves are of the piston type, 15 ins. in

pins in the usual way, while the high pressure ones are arranged with connecting rods made to enclose the for-

ward driving axle. This arrangement permits of the cylinder being placed not only with center lines on the same level—that is, all in one horizontal plane—but the front and back heads of all four are also in line, and the cylinders, valve and half saddle castings on each side are compact and solid.

The driving wheels are 81 ins. in diameter and are placed so close together that their flanges almost touch. The driving wheel base is 84 ins. The rigid wheel base is 15 ft. 9 ins., which takes in the carrying wheels at the back, while the total wheel base of the engine is 27 ft. 10 ins. The weights carried by the various sets of wheels are about 53,000 lbs. on the engine truck, about 46,000 lbs. on the carrying wheels, and about 110,000 lbs. on the drivers, making an estimated total weight of 209,000 lbs. With a boiler pressure of 200 lbs., the calculated tractive effort of this engine is about 28,400 lbs., and with the weight on the drivers as given above, the ratio of adhesion is 3.87; the engine can, therefore, develop a drawbar pull, when starting, of very nearly one-quarter of the weight on the driving wheels.

The crank axle is an interesting detail of construction, being made in several pieces. The central web is of cast steel, while the other parts are of forged steel. The web is really a heavy chunk of metal 8 ins. thick with an 8 in. offset like the short, solid coupling link which was carried on a yard engine in the old link-and-pin days. In the holes corresponding to those for the coupling pins, this crank web carries two crank pins, one at each end the full diameter of the axle; that is, 11 ins. These pins each have a fillet and are pressed into the web up to a hub and riveted over, while two keys, one in each pin, prevents any chance of them turning in the web. The pins have a 5 in. width and carry on their outer ends each a crank disc 36 ins. in diameter and 5 ins. thick, which is pressed on to the pins, up to a fillet and riveted over on the outside. Two circular 1 in. pins in each, hold crank pins and discs in the same relative position to each other. Into these crank discs the axles are pressed, riveted over and keyed by 1x1½ in. keys. The space from the outer face of the disc to the wheel seat is 10 ins. and the wheel seat is 7¼ ins. wide and 11 ins. in diameter. Counting the two short axles, the two crank discs, the two crank pins and the central web, there are seven pieces composing the main driving axle of this engine. The right hand crank on the axle, leads, and the hand crank pin on the wheel, leads.

The boiler is a straight top one, 70 ins. diameter at the smoke box end. The waist is composed of three courses arranged in telescope from back to front and these are welded at the longi-

tudinal joints for about 11 ins. at each end. These seams are strengthened by triangular welts on the outside which give the joints 96 per cent. of the total strength of the plates. The staying of the crown sheet is by T-iron crown bars. The flues are 2 ins. in diameter, 16 ft. long, and there are 297 of them. Each tube is 125 millimeters thick, and give in all a tube heating surface of 2,475 sq. ft. The fire box has 175 sq. ft. of heating surface in it, and together, the total comes up to 2,649 sq. ft. The grate area is 49½ sq. ft., so that the heating surface is to the grate area in the proportion of 1 to 53.3. The fire box back sheet slopes forward about 21 ins., and the roof sheet and crown sheet slope up 4 ins. at the front, though they are parallel to each other. The steam and water space above the crown sheet is 24 ins. The dome is a welded plate 31½ ins. in diameter and with ring and base is 22 ins. high. The ring and base are made of pressed steel.

The tender frame is of rolled steel channels mounted on arch bar trucks. The tank with its water bottom holds 9,000 U. S. gallons. The total wheel base of engine and tender is 58 ft. 5 ins., and the total weight of both together is about 371,000 lbs. A few of the principal dimensions are appended for reference:

Boiler—Thickness of sheets, 11/16 in.; working pressure, 200 lbs.; fuel, soft coal.  
 Fire Box—Material, steel; length, 108 ins.; width, 66 ins.; depth, front, 68 ins.; back, 64 ins.; thickness of sheets, sides, ¾ in.; back, ¾ in.; crown, ¾ in.; tube, ½ in.; water space, front, 5 ins.; sides, 5 ins.; back, 5 ins.  
 Driving Wheels—Diameter Outside, 81 ins.; journals, main, 11x10 ins.; others, 9x12 ins.  
 Engine Truck Wheels—Front, diameter, 33½ ins.; journals, 6x10 ins.  
 Trailing Wheels—Diameter, 51 ins.; journals, 8x12 ins.  
 Tender—Wheels, diameter, 33½ ins.; journals, 5½x10 ins.  
 Service—Passenger.

#### Boiler Explosion.

Our illustration on page 386 shows the result of the explosion of a locomotive boiler on one of our western roads. The engine had just been repaired and had been run out over the cinder pit when the explosion took place. There was one life lost through the explosion.

The pop valves tested by water pressure after the accident showed that they went off at 145 lbs. per square inch. The boiler was of ¾-in. iron plate, and the seam on the bottom of the barrel had been reinforced with an additional sheet ¾ in. thick. This sheet, with the original plates and the welt which united them, made a total thickness of 1¼ ins.

It has been suggested that the failure of the boiler at or near this seam was the cause of the explosion. In putting on this reinforcing strip, new rivet holes may have been drilled close to existing ones, and thus the sectional area of the plate may have been re-

## Old-Timer Talks No. 6



Maybe you've had trouble off and on with your air pump. There's a pretty severe strain on 'em with the heavy trains and high speeds nowadays. Pumps are apt to squeal or groan, overheat or labor; and packing rings wear and leak when they shouldn't.

Here's where Dixon's Special Graphite cures every time. Just take about a teaspoonful of the graphite and mix it with a pint of the regular oil. Use a little of this mixture at different times through the pump oil-cup.

There's no secret about Dixon's Graphite; lots of the boys use it now. Nothing like it when it comes to friction troubles of any kind. Why don't you write for sample No. 69-P? It's free for the asking.



Joseph Dixon Crucible Co.  
Jersey City, N. J.

# The Best and Cheapest Books for Railroad Men

## AIR BRAKE CATECHISM

Price, **\$2.00**

By Robert H. Blackall. 20th Edition. Contains 1500 Questions and their Answers on the Westinghouse Air Brake, which are strictly up-to-date. Includes two large Westinghouse Air Brake Educational Charts printed in colors. Gives the necessary information to enable a railroad man to pass a thoroughly satisfactory examination on the subject of Air Brakes. The author's many years' experience as Air Brake Inspector and Instructor enables him to know at once how to treat the subject in a plain, practical manner. Endorsed and used by Air Brake Instructors and Examiners on nearly every railroad in the United States. The standard and only complete work on the subject. 312 pages.

## LOCOMOTIVE BREAKDOWNS AND THEIR REMEDIES

Price, **\$1.50**

By Geo. L. Fowler. Just issued. Tells how and what to do in case of an accident or breakdown on the road; includes special chapters on Compound Locomotives. Better procure a copy, as it contains 800 Questions and their Answers on Accidents and Breakdowns.

## LOCOMOTIVE CATECHISM

Price, **\$2.00**

By Robert Grimshaw. 23d Edition. Is right up-to-date and contains twelve large Folding Plates and 1600 Questions and Answers on How to Run a Locomotive. The Standard Book on the subject, being written in plain language and free from mathematical formulæ and complex problems.

## NEW YORK AIR BRAKE CATECHISM

Price, **\$1.00**

By Robert H. Blackall. The only complete treatise on the New York Air Brake and Air Signaling Apparatus, giving a detailed description of all the parts, their operation, troubles, and the methods of locating and remedying the same. 250 Pages.

## COMBUSTION OF COAL AND THE PREVENTION OF SMOKE

Price, **\$1.50**

By Wm. M. Barr. Contains over 800 Questions and their Answers on the Science of Steam Making.

## AIR BRAKE CHARTS 50c.

Price, **50c.**

Showing the Westinghouse Equipment in ten colors, including freight and passenger engines. Every railroad man should possess these charts at this low price.

**A Special Circular** of any of these books sent on request. Any of these books sent prepaid on receipt of price.

**Agents Wanted at Every Terminal.** Write for our special terms. You can make equal to a month's pay selling our books on the side

**The Norman W. Henley Pub. Co.**

132 Nassau Street, New York, U. S. A.

duced. The sheet parted along the line of rivet holes at this seam.

The force of the explosion broke the frame, blew off a driving wheel, destroyed the barrel sheet just in front of the fire box. A new fire box had been put in and the number of flues reduced, so that in the round head or front flue sheet the extra number of holes had been stopped up with short pocket flues. Many of these pocket flues were blown out and a number of flues were collapsed by the pressure, and all were more or less distorted. The completeness of the wreck may be judged from the illustration.

### Cutting-off Machine.

The machine shown in our illustration is a cold metal cutting-off machine of modern design. It has been especially designed to drive a saw blade with inserted teeth of high speed steel such as

embedded in a socket and an alloy of hard zinc is run around the tool steel so that it and the socket are practically one piece. At the bottom of the socket there is a set screw, which, according as it is screwed in or out, regulates the height of the cutting edge of the saw tooth. We have seen such a saw as this get through a cut 9 ins. wide by 14 ins. deep, with 5/8 in. kerf in 20 minutes, and it was then estimated that an ordinary cold saw would have occupied about 4 hours in doing the same work. The saw itself is made by the Tabor Mfg. Co., of Philadelphia. In another column we give a specimen of the excellent work which this saw can accomplish, as demonstrated in the Elizabethport shops of the Central Railroad of New Jersey.

The Boston offices of Niles-Bement-Pond Company and the Pratt & Whitney Company have been removed from Pearl Street to more spacious and handsome

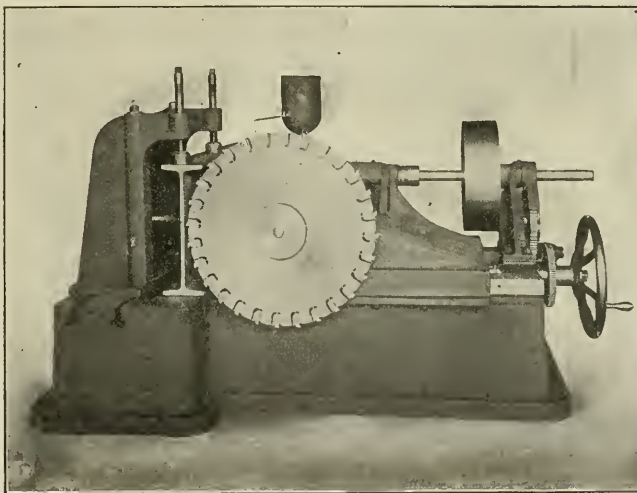

MODERN COLD METAL CUTTING OFF MACHINE.

the Taylor-Newbold saw, and is so constructed that it has ample power and stability to drive a saw blade of this description up to its limit of capacity. It is simple in construction, having very few parts to get out of order, and it is easily operated. The machine has a capacity for sawing 9 in. round steel bars, and is driven by a hammered crucible steel worm, phosphor bronze worm wheel and compound gearing made of hammered crucible steel cut from the solid. The feed is variable and automatic and is controlled by an automatic stop that regulates the depth of cut. It is one of the Espen-Lucas tools.

The Taylor-Newbold saw, with which the machine we show is fitted, is with teeth, and in each the cutting tool is

ly furnished quarters on the eighth floor of the Oliver Building, corner of Milk and Oliver Street, Boston. The policy of these companies is to dispense with showrooms, the variety of both heavy and light machine tools and cranes built by their several works being too great to permit of exhibition.

It is gratifying to observe from the British engineering press that the Kinnear steel roller-shutting doors are becoming popular in Europe. Comparative tests between the different forms of wooden doors of various thicknesses and makes, and roller shutters of the Kinnear type have demonstrated the superiority of the latter in every particular.

### Patent Office Department.

It is to be regretted that the Patent Office Department is about a year behind with its work. An ingenious inventor or clever mechanic conceives

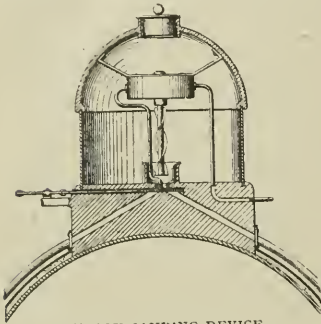

TRACK SANDING DEVICE.

some new device, and forthwith his peace of mind must be something sweet if he does not pass many anxious days and sleepless nights before he secures a legal right to call the invention his own. We select from a mass of inventions before us a few improvements relative to the details of the locomotive and other railway appliances. Nearly all of them have waited in the pigeon holes at the Patent Office over a year, or until the well paid examiners were good and ready. Doubtless it would be difficult to keep such work as promptly attended to as the inventors would wish, but if mechanical matters are treated in the ever-extending ratio which is now in vogue, the result will be that an inventor need not hope to secure a patent right to his work in his lifetime unless he makes his application while he is still a young man and has the promise of many years before him.

### COUNTERBALANCING WHEELS.

A method of balancing a crank wheel

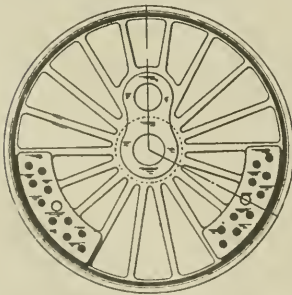

METHOD OF COUNTERBALANCING.

has been invented and patented, No. 823,750, by Mr. C. T. Westlake, St. Louis, Mo., consisting in forming the

counterbalance weights of less amount than that of the parts to be balanced. Recesses are formed in the counterbalance at each side of a radial line passing through the centers of the axis, the recess being symmetrically arranged so that the extra weight to be added can readily be distributed equally in the recesses, and the weight of crank pin correctly and readily balanced.

### TRACK SANDING DEVICE.

Mr. Albert G. Zamel, Chicago, Ill., has patented a track sanding device, No. 824,461, consisting of a sand box and an air motor supported therein. Pipes lead from the compressed air reservoir to the sander which is furnished with an agitating device which revolves and leads the sand to the outlet of sand box where there are diverging outlet channels.

### RAILROAD TANK CAR.

A railroad tank car has been patented by Mr. H. Small, of San Francisco, and Mr. J. B. Speed, Berkeley, Cal., No. 814,880. The tank is composed of cylindrical end sections, a middle cylindrical section of greater diameter than that of the end sections, and conical-shaped intervening sections uniting the end and middle sections, the tank sections being arranged to depress the central portion

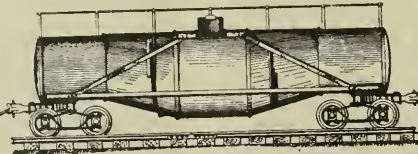

RAILROAD TANK CAR.

of the tank below the level of the ends. The wheeled trucks are furnished with a stress distributing plate under each end of the tank, with rivets passing through the plates and tank shell only. An interior stiffening truss comprising horizontal struts extends lengthwise of the bottom of the tank and bridges the depressed portion. There is also inclined struts extending from the ends of the horizontal struts to the middle top of the tank which is surmounted by a railing.

### RAILWAY CAR TRUCK.

A large number of improvements have been made by Mr. E. I. Dodds, of Pullman, Ill., in the mechanism of railway car trucks, and assigned to the Pullman Company, Chicago, Ill. The car bolsters consist largely of standard rolled beams, a standard rolled bar secured to each of the beams and a bottom plate fastened to the side members, giving the side frames or bolsters of the car something of the solidity of construction peculiar to the frames of locomotives on British railways. There is a similarly inverted beam for the cross central portion, to which the brake hangers are riveted, and

**"J. M."**



## RAILROAD SUPPLIES

### OUR NEW CATALOG

of "J.-M." Asbestos and Magnesia Railroad Supplies is now ready for distribution. This is the most complete catalog of its kind devoted entirely to Railroad Materials.

WRITE FOR CATALOG  
NO. 250-A TO-DAY

### A Few J.-M. Products

Smoke Jacks  
"Transite" Fireproof Lumber  
Asbestos and Magnesia Locomotive Lagging  
"Vulcabeston" Pump Packing  
"Vulcabeston" Gaskets  
"Vulcabeston" Rope Packing  
Train Pipe Covering  
"Kearsarge" Gaskets  
All grades of Asbestos and Magnesia Pipe Covering  
Hair Felt  
"Keystone" Hair Insulator  
Asbestos Cements  
"Retort" Cements  
"Canadax" Wick Packings  
High Pressure Asbestos Packing  
Asbestos Roofing  
Portland Sectional Conduit

### H.W. JOHNS-MANVILLE CO.

Manufacturers of Asbestos and Magnesia Products, Asbestos Roofings, Packings, Electrical Insulating Materials, "Nonark" Fuse Devices, Electric Railway Supplies, etc.

NEW YORK ST. LOUIS MINNEAPOLIS  
MILWAUKEE PITTSBURG DALLAS  
CHICAGO CLEVELAND SAN FRANCISCO  
BOSTON NEW ORLEANS LOS ANGELES  
PHILADELPHIA KANSAS CITY SEATTLE  
LONDON

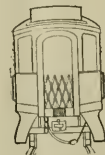

# GOLD Car Heating and Lighting Co.

Manufacturers of  
**ELECTRIC,  
STEAM AND  
HOT WATER  
APPARATUS  
FOR RAILWAY CARS**

**EDISON  
STORAGE  
BATTERY  
FOR RAILWAY CAR  
LIGHTING**

Largest Manufacturers in the World  
of Car Heating Apparatus

Catalogues and Circulars  
cheerfully furnished

Main Office, Whitehall Bldg.  
17 BATTERY PLACE  
NEW YORK

the whole structure has the elements of strength and durability in a very marked degree. Mr. Dodds secured a patent on the improved railway car truck, No. 825,035.

**BOILER FLUE CLEANER.**

An improvement in boiler flue cleaners has been patented by Mr. Charles Scheer, Silverton, Colorado, No. 815,043, consisting of a hollow tube provided with an expandible forward end and adjust-



**BOILER FLUE CLEANER.**

able scraping knives carried by the expandible end, and means for expanding the end to vary the diameter of the spiral scraper. The scraper blades are mounted in radial slots and are readily adjustable.

**ALARM SIGNAL.**

Mr. Richard W. Clery, Maryborough, Ireland, has secured a patent, No. 823,668, for an alarm signal arrangement for use in connection with railways. The device consists of a combination with a post and semaphore arm connected

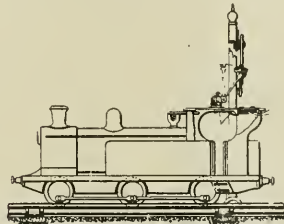

**CAB ALARM SIGNAL.**

thereto, and adapted to be contacted by means carried by a locomotive cab or other vehicle in conjunction with an alarm mechanism adapted to be set off by the movement of said means. The device is said to be already in operation on the railways in Ireland.

**METALLIC PACKING.**

Mr. Stephen T. Hiatt, Akron, Ohio, has secured a patent for an improved

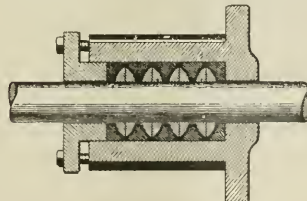

**METALLIC PACKING.**

metallic packing for piston or other movable rods, No. 824,692. The device consists of enclosing a metallic packing ring formed of oppositely disposed, similar contacting members, each member being formed of segments having their

ends spaced apart, with flexible connections between the parts, and a metallic cap surrounding the members and holding them in contact. There are flexible filling rings at opposite sides of the packing rings adapted to receive the convex faces of the rings.

**STEEL TIE.**

Mr. A. M. Baird, Newton, foreman of the rail department of the Santa Fe Railroad, has perfected a pressed steel metal tie and tie plate that bids fair to come into popular use. As is well known, the life of the wood ties run from one to six years, and when worn out they are worthless. The steel ties will last over twenty years and when worn out are worth about half their original cost. A wooden tie and tie plates and spikes cost about \$1.20. The hollow pressed steel tie and attachments as perfected by Mr. Baird costs about \$1.50 each. They are handled and laid down the same as wooden ties. They are made of a low carbon soft steel and the lugs which clamp the plate to the rails can be bent to a right angle many times without injury. Mr. Baird's patented improvement ought to be much in use, especially in the South and West, where the timber is not so plentiful.

**Carbonelastic.**

There is a paint on the market at the present time which is called "Carbonelastic Coating." It is said to be a combination of a specially prepared form of carbon with chemically pure linseed oil. The makers draw a distinction between what is commercially pure linseed oil and that which is chemically pure, and they claim that they thus effect a combination of the inorganic and the organic, by careful and watchful manipulation and as the result of an intricate process.

The outcome of all this is the production of a paint for the preservation of iron and steel which is not affected by the sulphur fumes, in smoke, the brine of the ocean, the acids or alkalis in more or less contaminated water, and which is able to adapt itself to changes of temperature. It is therefore available for use on train sheds, roundhouses, wharves and steel buildings of all kinds.

One of the forms in which Carbonelastic paint is made is known as Quick-dry, and this is the form suitable for use on steel cars as it practically covers the structure with a non-porous skin which, having the ability to expand and contract with the metal on which it lies, does not crack or peel off. This form of Carbonelastic paint possesses the quality of being able to cover a considerable area, and as it has sufficient body to resist the scratching action of cinders and flying particles of dust, and as it resists the acid action of wet coal or ore, it is a desirable material for use in car

repair work as well as for new equipment. This paint is made by the Arlington Mfg. Company, of Canton, Ohio, who will be pleased to furnish information to those interested in this important subject.

#### Mica Chimneys.

Some of the principal roads in this country are using headlight and lantern



MICA LANTERN GLOBE.

chimneys made of mica. The chimneys we have seen and which come from the Storrs Mica Company, of Owego, N. Y., were made of beautiful pieces of clean, transparent mica bound top and bottom with rims of tin. The chimneys are made slightly conical for the purpose of increasing the draught, and where the segments of mica join, a narrow strip of tin runs down to hold them in place.

The heat resisting properties of mica render it more durable than glass, and while costing more in the first instance, it shows a considerable saving in the long run. These chimneys insure against total loss of light due to blowing out of the flame, as when glass chimneys break. The mica chimney prevents the smoking up and blacking of reflectors and makes it impossible for the headlight to burn up, which sometimes happens when a glass chimney breaks, and the wind drives the flame down to the oil reservoir. The headlight chimneys have been in use since they were brought out in 1900.

The lantern globe has been more recently put upon the market. There is a slide for lighting the wick which can be used without the necessity of removing the bottom of the lantern, and this is the most recent improvement in the lantern globe. This opening may also be used for adjusting the height of the flame by inserting a match stick and bearing on the burner wheel.

The Erie Railroad have just placed orders for 1,600 new freight cars from the Standard Steel Car Company, to be built at the Butler, Pa., shops, and have

ordered 500 drop and steel underframe gondola cars of 100,000 lbs. capacity, weighing 42,600 lbs. each, being 45 ft. in length. These are for delivery in January, 1907. For delivery in December next, the Erie have also ordered 500 flat cars, to be built by the same company. These will be 40 ft. in length, with steel underframes and a capacity of 100,000 lbs. At the American Car & Foundry Company's works at Chicago there are building 500 produce cars for delivery in November and December next. These are also steel underframe cars, 36 ft. in length and of 80,000 lbs. capacity. At the same company's Detroit works they are building for the Erie 100 Hart convertible cars for delivery next January. These are to be of 100,000 lbs. capacity and will weigh 43,000 lbs. each. They will be 41 ft. 6 ins. in length, with wood bodies and steel under frames. Five new electric cars for the Rochester division have been ordered from the St. Louis Car Company for the line to Mt. Morris now being electrically equipped. Four of these are passenger cars and the fifth a combination passenger and baggage car. Each will be equipped with four 75 h.p. Westinghouse motors.



MICA HEADLIGHT CHIMNEY.

A monument to the late Sir James Hector and his son, of New Zealand, has just been erected by scientists and railway men, on Mount Hector, in British Columbia. He was the scientist of the exploration party which discovered the Kicking Horse Pass through which the main line of the C. P. R. runs, and the pass was so named by the Indians because Sir James at

## Homestead Valves

Straightway, Three-way and Four-way, and

## Homestead Locking Cocks

Are Famous the World Over

They cost more, but are worth very much more than other makes. You try them and see.



Brass, 1 1/4 in., \$8.00 net

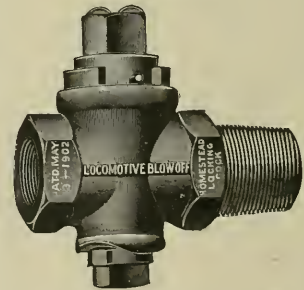

Iron Body, Brass Plug, 1 1/4 in., \$4.00 net

Homestead Valve Mfg. Co.

WORKS, HOMESTEAD, PA. PITTSBURG, PA.

## American Locomotive Sander Company

13th & Willow Sts., Philadelphia, Pa.

Proprietors and Manufacturers

LEACH, SHERBURNE, DEAN, HOBSTON, "BRI" and CURTIS SANDERS

THE ROBERT W. HUNT & CO.

Bureau of Inspection, Tests and Consultation, 1137 THE ROOKERY, CHICAGO.

66 Broadway, New York. Park Building, Pittsburgh. 31 Norfolk House, London, Eng.

Inspection of Steel Rails, Splice Bars, Railroad Cars, Wheels, Axles, etc. CHEMICAL LABORATORY—Analyse of Ores, Iron, Steel, Oils, Water, etc. PHYSICAL LABORATORY—Test of Mqiale, Drop and Pulling Test of Couplers, Draw Bars, etc.

Efficiency Tests of Boilers, Engines and Locomotives.

## Locomotive Blow-Off Plug Valves

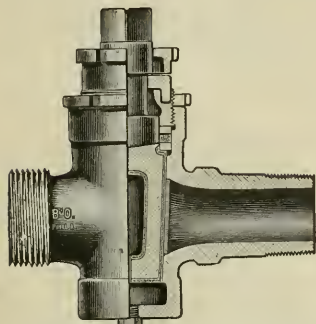

Fig. 9.

All Brass, extra heavy, with Cased Plug. For 250 lbs. pressure. Made with Draining Plug to prevent freezing.

## Locomotive Gauge Cocks

For High Pressure

Bordo Self-Grinding Gauge Cocks, made with renewable Hard Bronze Disc. Opened and closed with a quarter turn. Guaranteed Steam tight under the most exacting conditions. Shanks Threaded to specifications for Locomotives.

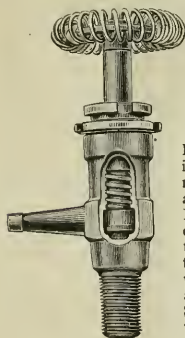

Fig 23, with Wheel.

## Swing-Joints and Pipe Attachment

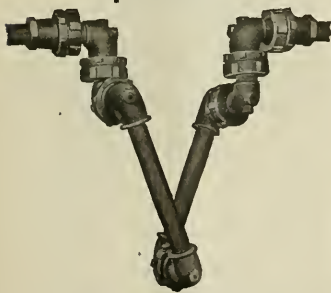

Fig. 33.

May be applied between Locomotive and Tender. These Swing-Joints are suitable for Steam, Gas, Air, Water or Oil.

Complete Booklet on Application

**L. J. BORDO CO.**  
PHILADELPHIA, PA.

that time was almost killed by a kick from his horse.—World Wide.

The H. W. Johns-Manville Co., of 100 William Street, New York City, have for a number of years been meeting with remarkable success in the installation of their J.-M. Combination Felt Coverings on pipes in mines and surfaces exposed to extreme weather conditions. In several instances they have demonstrated the feasibility of carrying steam considerably over a mile. Good results have been obtained when the J.-M. Combination Felt Coverings were applied. The manufacturer maintains a force of thoroughly skilled mechanics for the installation of this covering in all parts of the country. The H. W. Johns-Manville Co. will be glad to give full information regarding this product to anyone interested enough to write to them concerning it.

The Railroads, Their Employees and the Public, by John E. Niles, Boston, is a handsome volume of 200 pages, being discourses on the rights, duties and obligations of each toward the other. Mr. Niles is a railroad man of experience and is at present running a locomotive on the New York, New Haven & Hartford Railroad. He is a keen observer and in his leisure hours has devoted much time to the questions that affect the social well-being of the railroad employees. Mr. Niles has aimed at uniting more closely the great railway corporations with their employees as well as to enlist the intelligent sympathy of the general public. He believes in open methods in the transactions of the railroads as well as in the councils of labor organizations, and the leading men in all the various departments of railroad traffic would do well to peruse Mr. Niles' book, much of which

Boston, as well as with prominent railway officials in Canada, and, altogether he has equipped himself well for the task which he set before him in presenting in concrete form the views that have come to him on the important questions that affect the mutual welfare of rail-

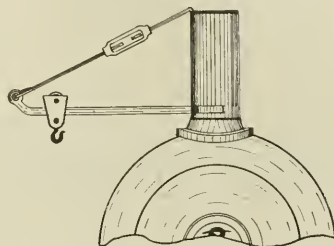

IMPROVEMENT IN SMOKESTACK CRANE.

road men. Mr. Niles sells his book for \$1.00, plus 12 cents for postage.

### Adjustable Shop Crane.

The shop crane used for lifting steam chests, etc., which can be hooked over the top of the smoke stack and bears against its base, has been modified in the Monett, Mo., shops of the St. Louis & San Francisco. In that shop they use a turn buckle on the "tension member," as shown in the sketch.

In the usual form of crane, when the weight comes on the hook, the effect of all the lost motion and the spring of the parts is concentrated at the angle. The Frisco shop crane can be readily adjusted so as to bring things just right and keep the horizontal bar level, or sloped somewhat towards the stack, if that is required. The flat iron bar and the permanent trolley are also features of this handy shop appliance. We are indebted to Mr. John F. Long, gang foreman on the Frisco System, at Monett, Mo., for the sketch.

### Opportunity.

It is said that the green fields of opportunity lie beyond the hills of effort. There is some truth in this, but it is not the whole truth. Opportunity often comes without effort and even without invitation. Success in life depends greatly on being able to grasp opportunity when it does come. Capability is an important prerequisite to real success, and in the important department of railroad operation it is the capable man who achieves enduring success. The forceful man of ability creates opportunity, and in the words of the poet Tennyson, "Breasts the blows of circumstance and grapples with his evil star." Every employee can afford to read and few can afford in these days of multitudinous mechanical contrivances to do without the help afforded by



IT HAS NOT RUN OVER ANYTHING: IT WAS MADE THAT WAY.

is devoted to extracts from the legislative enactments of Massachusetts and other States. We may add that in the collection of material for this work Mr. Niles had repeated conferences with the Board of Railroad Commissioners, at

the experience of others as set down in books. In this sense helpful books assist in preparing one for the opportunities of life. A few of our books are as follows:

"Machine Shop Arithmetic." Colvin and Cheney. This is a book that no person engaged in mechanical occupations can afford to do without. Enables any workman to figure out all the shop and machine problems which are so



THE WAR GAME—BRIDGE THROWN DOWN LIKE A CHILD'S TOY.

puzzling for want of a little knowledge. We sell it for 50 cents.

"Firing Locomotives." Sinclair. Treats in an easy way the principles of combustion. While treating on the chemistry of heat and combustion, it is easily understood by every intelligent fireman. The price is 50 cents.

"Skeevers' Object Lessons." Hill. A collection of the famous object lesson stories which appeared in this paper several years ago. They are interesting, laughable, and, best of all, they are of practical value to-day. \$1.00.

"Standard Train Rules." This is the code of train rules prepared by the American Railway Association for the operating of all trains on single or double track. Used by nearly all railroads. Study of this book would prevent many collisions. Price, 50 cents.

"Mechanical Engineers' Pocketbook." Kent. This book contains 1,100 pages, 6x3¼ ins. of closely printed minion type, containing mechanical engineering matter. It ought to be in the bookcase of every engineer who takes an interest

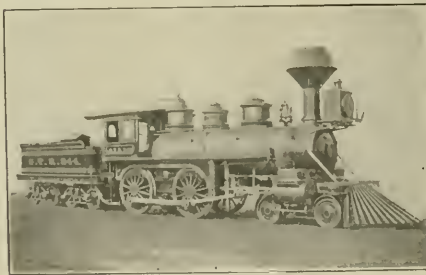

ONE OF THE EARLY ENGINES ON THE GRAND TRUNK RAILWAY BUILT BY THE BALDWIN LOCO. WORKS.

in engineering questions. We use it constantly as a reference for questions sent to us to be answered. Full of tables and illustrations. Morocco leather, \$5.00.

"Locomotive, Simple, Compound and Electric." Reagan. An excellent book

for people interested in any kind of locomotive. It will be found particularly useful to men handling or repairing compound locomotives. It is the real locomotive up to date. \$2.50.

"Simple Lessons in Drawing for the Shop." By O. H. Reynolds. This book was prepared for people trying to acquire the art of mechanical drawing without a teacher. The book takes the place of a teacher, and has helped many young men to move from the shop to the drawing office. 50 cents.

"Locomotive Running Repairs." By L. C. Hitchcock. This book contains directions given to machinists by the foreman of a railroad repair shop. It tells how to set valves, set up shoes and wedges, fit guides, care for piston packing, and, in fact, perform all kinds of work that need a thoughtful head and skilful hands. 50 cents.

"Care and Management of Locomotive Boilers." Raps. This is a book that ought to be in the hands of every person who is in any way interested in keeping boilers in safe working order. Written by a foreman boilermaker. Also contains several chapters on oil burning locomotives. Price, 50 cents.

"Locomotive Link Motion." Halsey. Any person who gives a little study to this book ceases to find link motion a puzzle. Explains about valves and valve motion in plain language. Price, \$1.00.

RAILWAY AND LOCOMOTIVE ENGINEERING is a practical journal of railway motive power and rolling stock, and it is so not only in name but in reality. By reading it you get a knowledge of what others think and do. \$2.00 a year; bound volumes, \$3.00.

**Helping Passengers.**

The story is told of an Irish porter, employed on one of the railways of the Emerald Isle, who indignantly remon-

strated with a passenger holding a first class ticket for riding in a third class compartment, on the ground that the traveler was "cheating the company." It may have been a relative of his who, as he walked down a platform, put his head in at each carriage window, and asked, "Is there any one there for here?" But even this genius was eclipsed by a brother on the line, who, before the departure of an express train, fiercely rang a bell, and shouted in warning tones, "This train stops nowhere at all."

A superbly finished catalogue, No. 57, has just been issued by the Baldwin Locomotive Works, of Philadelphia, Pa. It presents a very interesting record of

# Tate Flexible Staybolt



Strong  
Effective  
Economical

Flexibility  
Durability  
Simplicity

Holds firebox sheets securely together, and accommodates itself to the unequal expansion of the plates.

## FLANNERY BOLT COMPANY

PITTSBURG, PA., U. S. A.

Suite 308, Frick Bldg.

B. E. D. STAFFORD, - - General Manager

Write us for Reference Book



**THE ELASTIC SELF-LOCKING STEEL NUT**



Blank Cut from Flat Bar of Steel



2nd Operation      Finished Nut

The elastic nut positively locks itself on the bolt wherever placed, and cannot work loose. Send for Circulars.

**Quincy, Manchester-Sargent Co.**  
Old Colony Building CHICAGO      114 Liberty Street NEW YORK

**SKAT**

is a soft soap sold in a neat lithographed can. When you wash up with SKAT, it gets into the cranies and "hard to reach" corners of your hands and the results are surprising. That's where the dirt lurks and hard soaps won't go. That's why SKAT is so popular. SKAT is made of the best materials, is absolutely pure and guaranteed to give you perfect satisfaction. You'll use it every day and like it more each time.

We can tell you where to buy SKAT, or better still show you how to sell it. If SKAT is not for sale in your locality, let us give you the selling right. Drop us a postal and get a free sample.

**SKAT MFG. COMPANY**  
Hartford - - Conn.

**A Practically Perfect Portable Pneumatic**

**PUNCH**



Stop moving your heavy work to the machine. One Man brings this tool to the work and punches it besides.

**SAVES TIME LABOR SPACE**

Leading concerns in all parts of the country use this Punch.



Built in 5 Standard Sizes. Special machines built to order. Write for Catalogue C.

**F. F. SLOCOMB & CO., Builders**  
WILMINGTON, DEL.

recent construction embracing the locomotive equipment of the "Associated Lines," which comprise the Southern Pacific, Union Pacific, Oregon Short Line, Oregon Railroad & Navigation Company and the Chicago & Alton Railroad. It may be stated that in 1903 a plan for standardizing the locomotive equipment of these lines was agreed upon by the general managers and other officers, and the designs for the standard locomotives were prepared at the Baldwin Locomotive Works. The engines already in operation embrace almost every approved type from the six-wheel switching locomotive to the ten-wheel balanced compound 4-6-2 type. In each particular type the large parts are interchangeable, and nearly all of the chief working parts are made in two sizes. All journals are nine inches by twelve inches except the main journals on the Consolidation and Pacific type engines, which are ten inches by twelve inches. The eccentric straps are particularly strong in every class, being made of cast steel and furnished with a brass bearing ring measuring three inches wide by one inch thick. The twelve inch piston valves are in universal use on all road engines. They have inside admission and work in cast iron bushings. Indeed, the great mass of the smaller fittings and details are common to all engines, and every page of the beautifully illustrated catalogue shows how successfully the Baldwin people have succeeded in unifying the working parts of the locomotives on these Western roads. Write to Burnham, Williams & Company, of Philadelphia, if you would like to have a copy.

**WANTED — POSITION IN THE MECHANICAL DEPARTMENT OF A RAILWAY** by a former Motive Power Officer, until recently and for a number of years in active service. Address X Y Z, care Railway and Locomotive Engineering.

**THE UNION SWITCH & SIGNAL CO.**

Consulting and Manufacturing  
Signal Engineers

Automatic Block Signals—Electric and Electro-Pneumatic  
Interlocking—Electric, Electro-Pneumatic and Mechanical  
Electric Train Staff Apparatus

The Safety Car Heating and Lighting Co., of New York, have published a handsome new catalogue covering the use of the incandescent mantle lamps for Pintsch gas, and also a new edition of their catalogue for steam heating. The gas lighting system has been in use for many years and has earned an enviable reputation that needs no recommendation. The variety of gas fixtures shown are elegant in design. The heating system has made very marked progress during the year and has now reached a high degree of perfection. The designs shown in the illustrated catalogue are applicable to nearly all coaches, without the necessity of making radical changes. All that is necessary is to furnish the company with a floor plan of the car, having position of the needle beams, gas tanks, equipment boxes and location of brake cylinders marked. The company will thereupon promptly furnish designs for the introduction of their heating system, which is particularly applicable to sleeping cars, parlor, dining and café cars, large postal cars, private cars, and, in short, every variety of railway vehicle for the accommodation of passen-

**GENERAL OFFICES AND WORKS AT SWISSVALE, PA.**

**DISTRICT OFFICES:**  
New York: 143 Liberty Street  
Chicago: Monadnock Block  
St. Louis: Frisco Building

**Flexible Spout**

Vertically in straight line. Also laterally. The latest improvement to

**Poage Water Columns**

**American Valve and Meter Company**  
CINCINNATI, OHIO  
—SEND FOR CATALOGUE—

# World's Fair

St. Louis

FIRST PRIZE FOR

# TOOL STEEL

AWARDED TO

McInnes Steel Co.

CORRY, PA.

in competition with the best makes in England and Germany. Also manufacturers of all kinds of Tool Steel, Die Blocks, and Steel Forgings.

Write for Prices and Information

STANDARD MECHANICAL BOOKS  
FOR ROAD AND SHOP MEN  
BY CHAS. McSHANE

The  
Locomotive Up to Date

Price, \$2.50

New York and  
Westinghouse Air Brakes

Price, \$1.50

One Thousand Pointers for  
Machinists and Engineers

Price, \$1.50

All books bound in fine cloth

AGENTS WANTED everywhere; write for terms and descriptive circulars. Will be sent prepaid to any address upon receipt of price.

GRIFFIN & WINTERS  
171 La Salle Street, CHICAGO

gers. Each design embraces the use of the double circulation Baker Heater, which in point of economy and durability, meets the requirements of the situation in an eminent degree. Perhaps the most admirable feature in the heating system is, as explained in the catalogue, the fact that the valves and traps and other accessories are self-acting. Write direct to the company for one or both of these catalogues.

### Plain Milling Machine.

This machine embodies a number of improvements which are likely to be appreciated by users of plain milling machines. Attention is directed to the positive gear feed drive and the change feed mechanism, by which twenty changes of feed can be made without stopping the machine. There is a new clutch mechanism in connection with the hand wheels, and also this machine is equipped with the box type of knee and telescopic elevating screw.

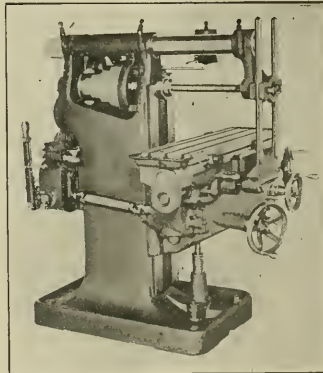

IMPROVED PLAIN MILLING MACHINE.

The spindle has a taper hole in the front end, it is made of hammered crucible steel, with a  $21/32$  in. hole through its entire length and it runs in self-centering bronze boxes arranged to compensate for wear. It has a dust cap on its front end, threaded to take a chuck, and a threaded collar covers the screw when not in use. It is connected with the change feed mechanism by three spur gears, making a positive driven feed. The spindle is fully back geared, and gears are protected with guards.

The arm is made of steel designed for horizontal adjustments and has an arbor support which may be removed so that any of the attachments may be placed in position without the necessity of removing the arm. The platen has an automatic longitudinal and cross feed in either direction and is provided with three T slots with oil channels and pans. It has also a quick return with fine and coarse hand feed. The knee is of the

## Dart Patent Union

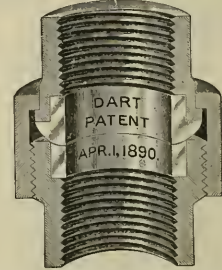

Every feature of construction represents the best points to insure stability and durability. The malleable iron pipe ends and nuts, in combination with bronze metal seats, are as near perfection as is possible to approach, and the sales to date indicate the public approval. There are none so good. For sale by all the principal jobbers in United States, Canada and Europe.

E. M. Dart Mfg. Co., Providence, R. I.

FAIRBANKS CO., SALES AGENTS.



## The Twentieth Century Master Mechanic

Won't use Solid Mandrels.  
Cost too much, take up too  
much room and don't give  
satisfaction.

### Nicholson Expanding Mandrels

Take everything from 1 to 7  
inch holes. Take up little  
room — always ready and  
you can buy four sets for  
the cost of one of the solid  
kind

### Are You Using Them?

Catalogue tells you  
more about them.

W. H. Nicholson & Co.  
Wilkesbarre, Pa.

# Locomotives, Freight and Passenger Cars

All equipment rebuilt in our Chicago shops, and at Scranton, Pa., in the new "Lackawanna" Shops

## All Kinds of Cars and Engines Ready for Immediate Delivery

RELEASED BY TRUNK LINES

1000—60,000 LBS. CAPACITY REBUILT FLATS AND GONDOLAS  
 2000—50,000 LBS. CAPACITY FLATS, BOX AND GONDOLAS  
 COACHES, COMBINATION AND BAGGAGE CARS  
 FOREIGN SHIPMENTS HAVE PROPER CARE OF  
 EXPERIENCED STAFF

Cable Address  
 "FITZLUTH"

55 AND 70 TONS CONSOLIDATIONS  
 45 AND 50 " 10-WHEELERS  
 40 TO 55 " MOGULS  
 45 TO 56 " PASSENGERS  
 SWITCHERS, FORNEYS AND SHAY ENGINES

### FITZ-HUGH, LUTHER CO., Monadnock Block, CHICAGO

141 BROADWAY NEW YORK      CHEMICAL BLDG. ST. LOUIS      80 ST. FRANCIS XAVIER ST. MONTREAL, CAN.      RIALTO BLDG. SAN FRANCISCO

box type and is supported by a telescopic elevating screw, so that no holes are necessary in the floor. The machine can also be provided with automatic vertical feed and knock off, if desired.

Hand wheels are provided each with clutch arrangements in the hub which operate the vertical movement of the knee and cross and longitudinal movements of the carriage. When either the knee or carriage has been set to the required position, the clutch may be instantly disengaged by pressing in the knob on the front of the hand wheel, thereby preventing any accidental change from their fixed position and also preventing the knee and the carriage from revolving when the automatic feeds are thrown in.

Dials are provided which are adjustable and graduated to read to thousandths of an inch, these indicate the vertical, transverse and longitudinal movements of platen, and may be set at any position with set screw. The change feed mechanism is conveniently arranged on the back of the column and is capable of giving any one of twenty changes of feed, slow or fast, by a simple movement of the lever, and this may be accomplished without stopping the machine. The Becker-Brainard Milling Machine Company, of Hyde Park, Mass., are the makers of this serviceable tool.

Whiting Foundry Equipment Co., of Harvey, Ill., have recently issued their Catalogue No. 45. It contains 162 pages, and illustrates and describes electric travelers and cranes of all types. It has also over one hundred illustrations of recent crane installations in foundries, machine shops, railway shops, power houses, steel plants, etc., including, besides electric travelers and hand power cranes, numerous jib and bracket cranes, pillar cranes, gantry cranes, transfer cranes, electric transfer tables, special derricks for railroad and marine service, etc. The catalogue is printed in two colors and has an attractive cover which is designed to suit the sectional cata-

logue binder issued by this company. Write direct to the company at Harvey, Ill., which is a suburb of Chicago, and ask for a copy of this catalogue if you are interested.

#### Accident at Salisbury.

The coroner's inquest into the cause of the wreck of the Plymouth steamer express at Salisbury, England, on July 1, whereby 27 lives were lost, resulted in a verdict that the derailment of the train was due to the high speed at which it was running, and which was contrary to the company's orders. The jury allowed the verdict to be recorded as one of accidental death, saying they considered that a certain amount of blame attached to the company as well as to the engine driver. The Railway department of the Board of Trade are conducting a searching inquiry into the cause of this disaster and their report to the government will authoritatively place the blame where it belongs.

#### Cunard Liner "Lusitania."

The launching of another 25-knot Cunard steamship on the Clyde last month, marks another step in maritime engineering progress, which is being watched with keen interest. The fact that the British Government entered into some kind of an agreement with the Cunard Company, aiming at the importance of maintaining British supremacy in respect of speed, gives the appearance of the new ship something of the importance of an international character.

The new ship "Lusitania" is larger than her sister ship the "Mauretania," being 785 ft. in length and 88 ft. in breadth of beam, with a gross tonnage of 32,500 tons. The engines are of the turbine type, three in number, and are supplied with steam from 25 cylindrical boilers heated by 192 furnaces having a heating surface of 160,000 sq. ft. The horse power approaches 68,000, and the designed speed is 25 knots.

## METAL PRESERVATIVE PAINTS AND PRIMER

for locomotives, boilers, stacks, front-ends, gearing, framework, metal roofs, etc.

Tell us your needs. Metal preservative paints have been our specialty for 22 years. Paints for all conditions.

THE STANDARD PAINT CO.

Sole Manufacturers  
 100 William St., New York  
 CHICAGO ST. LOUIS

#### CONTENTS :

	PAGE.
*Cantilever Bridges .....	353
Why Johnson Wasn't Fired .....	356
Book Notices .....	370
*Our Correspondence School.....	373
Questions Answered .....	375
*Air Brake Department.....	377
Casehardening and Potashing.....	381
*Train Shed, Smokeless, D., L. & W.....	382
Personals .....	385
*Boller Explosions .....	388
*Patent Office Department.....	390
*Mica Chimneys .....	392
Carbonelastic .....	391
Cars:	
*New Wagon Stock, British, A. R. Bell.....	358
*Tunnel Spray Car, Central London.....	380
*High Side, Steel Hopper, Lehigh Valley.....	384
Locomotives:	
*Texas & Pacific 4-4-2.....	371
*Union Pacific 4-4-2.....	387
*Heavy 2-8-0 for Cuba.....	389
Editorials:	
Modern Master Mechanics.....	368
Boiler Explosion, Locomotive.....	368
Fatigue of Metals.....	369
Collision Study, Locomotive.....	369
Wise Eyes Are Odd.....	369
Once Used, Never Again.....	370
Robbed of Sleep.....	370

TRADE MARK  
The Sargents Glove



"WRIST OR GAUNTLET"

TRY THEM

They are made for hard wear from the very best grade of chrome tanned horsehide leather. Heat and water proof. No rivets nor seams to hurt the hands.

If your dealer does not carry "Sargents" we will sell you direct on receipt of your size and \$1.00

Write for free leather match safe and descriptive booklet

DETROIT LEATHER SPECIALTY COMPANY, Detroit, Mich.

TALMAGE SYSTEM

A MECHANICAL SYSTEM FOR LOCOMOTIVES THAT OVERCOMES THE BAD EFFECTS FROM THE USE OF UNDESIRABLE FEED WATERS

PATENTED IN UNITED STATES AND FOREIGN COUNTRIES

RUBRA BOILER OIL

TALMAGE BLOW OFF VALVES

USED IN CONNECTION

GUARANTEE

WE GUARANTEE TEN TIMES GREATER MILEAGE BETWEEN BOILER WASHINGS AND TO REDUCE MOTIVE POWER EXPENSES SUFFICIENT TO MAKE THE COST OF OUR SYSTEM PERMISSIBLE.

THE TALMAGE MANUFACTURING COMPANY

CLEVELAND, O., U. S. A.

J. G. TALMAGE, President

INDEX TO ADVERTISEMENTS.

Acme Machinery Co. . . . .	Front Cover
Air Brake Chart . . . . .	—
Ajax Metal Co. . . . .	4th Cover
Alcoa Co. . . . .	—
American Balance Valve Co. . . . .	4th Cover
American Brake Shoe Co. . . . .	15
American Loco Sander Co. . . . .	393
American Locomotive Co. . . . .	8
American Locomotive Equipment Co. . . . .	4th Cover
Armstrong Valve and Meter Co. . . . .	395
Armstrong Bros. Tool Co. . . . .	2d Cover
Armstrong Mfg. Co. . . . .	8
Audel, Theo. Co. . . . .	—
Baker, Wm. C. Heating and Supply Co. . . . .	5
Baldwin Locomotive Works. . . . .	10
Ball Webb, G. & Co. . . . .	4th Cover
Barnett, G. & H. Co. . . . .	2d Cover
Barrett Machine Tool Co. . . . .	—
Bettendorf Axle Co. . . . .	19
Big Four Railroad. . . . .	9
BOOKS—	—
Air Brake Chart . . . . .	—
Compound Locomotives. . . . .	—
Computers . . . . .	25
Conger's Air Brake Catechism . . . . .	—
Firing Locomotives. . . . .	20
Locomotive Running and Management . . . . .	9
Machine Shop Arithmetic. . . . .	—
Miscellaneous. . . . .	20
Oil Burning in Locomotives. . . . .	8
Train Rules and Train Dispatching. . . . .	4th Cover
Twentieth Century Locomotive. . . . .	8
Bordo, L. J. Co. . . . .	393
Boston & Albany R. R. . . . .	16
Boston & Maine R. R. . . . .	9
Carpenter, The J. M., Tap & Die Co. . . . .	17
Central R. R. of New Jersey. . . . .	19
Chalfonte Hotel. . . . .	12
Chapman Jack Co. . . . .	7
Charts—	—
Combination Passenger & Sleeping Car. . . . .	12
Locomotive, Atlantic Type. . . . .	12
Locomotive, American Type. . . . .	9
Chicago Car Heating Co. . . . .	13
Chicago Pneumatic Tool Co. . . . .	16
Chicago & Alton R. R. . . . .	18
Cleveland City Forge & Iron Co. . . . .	4th Cover
Cleveland Twist Drill Co. . . . .	18
Climax Bearing Co. . . . .	16
Commercial Acetylene Co. . . . .	24
Commonwealth Steel Co. . . . .	3
Consolidated Railway, Electric Lighting & Equipment Co. . . . .	8
Crandall Packing Co. . . . .	349

Damascus Bronze Co. . . . .	23
Darr, E. M., Mfg. Co. . . . .	6
Davis, John Co. . . . .	23
Detroit Leather Specialty Co. . . . .	1
Detroit Lubricator Co. . . . .	13
Detroit Seamless Tube Co. . . . .	21
Dixon, Joseph, Crucible Co. . . . .	388
Expanded Metal Co. . . . .	3
Falls Hollow Staybolt Co. . . . .	14
Franklin Mfg. Co. . . . .	2
Fay & Egan Co., J. A. . . . .	3
Fitz Hugh Luthur Co. . . . .	398
Flanders, L. B., Machite Works. . . . .	11
Flannery Bolt Co. . . . .	394
Greene, Tysed & Co. . . . .	2
Galena Signal Oil Co. . . . .	2
Gariock Packing Co. . . . .	18
General Electric Co. . . . .	19
Gold Car Heating Co. . . . .	391
Goodrich Rubber Co. . . . .	9
Gould Coupler Co. . . . .	18
Grand Trunk Ry. . . . .	16
Greene, Tysed & Co. . . . .	2d Cover
Griffin & Winters. . . . .	396
Hammett, H. G. . . . .	4th Cover
Hancock Inspirator Co. . . . .	22
Henjens Mfg. Co. . . . .	392
Henley & Co. . . . .	389
Hicks, P. M., & Co. . . . .	14
Hoffman, Geo. W. . . . .	18
Hornstead Valve Mfg. Co. . . . .	392
Hunt, Robert W., & Co. . . . .	392
Illinois Central R. R. . . . .	26
International Correspondence Schools. . . . .	9
Jenkins Bros. . . . .	4th Cover
Johns-Manville, H. W., Co. . . . .	390
Kennicott Water Softener Co. . . . .	5
King-Lawson Car Co. . . . .	3d Cover
Kinnear Mfg. Co. . . . .	2d Cover
Lackawanna R. R. . . . .	—
Lake Shore. . . . .	17
Latrobe Steel. . . . .	19
Latrobe Steel & Coupler Co. . . . .	8
Locomotive Charts:—	—
Atlantic Type. . . . .	—
Locomotive Publishing Co., Ltd. . . . .	16
Long & Alkistater Co. . . . .	17
Magnus Metal Co. . . . .	4
McConway & Torley Co. . . . .	11
McCord & Co. . . . .	2d Cover & 2
McInnes Steel Co. . . . .	396
Morse Twist Drill Co. . . . .	13
Mumford, The E. H., Co. . . . .	349
New Jersey Asbestos Co. . . . .	17
Nathan Mfg. Co. . . . .	14
National Acme Mfg. Co. . . . .	5
National Malleable Castings Co. . . . .	4th Cover
New Jersey Asbestos Co. . . . .	15
New York Central R. R. . . . .	7
Nicholson, W. H., & Co. . . . .	396
Niles-Bement-Fond Co. . . . .	3
Norton Grinding Co. . . . .	1
Norwalk Iron Works. . . . .	14
Pacific Trading Co. . . . .	18
Pennsylvania R. R. . . . .	2
Pittsburgh Spring & Steel Co. . . . .	2
Porter, H. K., & Co. . . . .	17
Pratt & Whitney . . . . .	3
Pressed Steel Car Co. . . . .	10
Prosser, Thos., & Son. . . . .	16
Quincy, Manchester Sargent Co. . . . .	395
Railway Materials Co. . . . .	2d Cover
Railway Steel Spring Co. . . . .	10
Ralston Car Co. . . . .	4
Revere Rubber Co. . . . .	3d Cover
Rogers, H. A., Co. . . . .	2
Rogers Locomotive Works. . . . .	17
Ross Valve Co. . . . .	4th Cover
Rue Mfg. Co. . . . .	18
Safety Car Heating & Lighting Co. . . . .	11
Saunders, D., Sons. . . . .	14
Scandiaavis Belting. . . . .	15
Sellers, Wm., & Co., Inc. . . . .	2
Sight Feed Oil Pump Co. . . . .	—
Slat Mfg. Co. . . . .	395
Slocumb, F. F., & Co. . . . .	395
Smooth-On Mfg. Co. . . . .	9
Southern Pacific R. R. . . . .	16
Standard Car Truck Co. . . . .	2d Cover
Standard Coupler Co. . . . .	15
Standard Paint Co. . . . .	398
Standard Steel Works. . . . .	10
St. Louis Car Co. . . . .	21
Star Brass Mfg. Co. . . . .	2
Starrett, Co., L. S. . . . .	19
Storrs Mica Co. . . . .	397
Swanton, T. H., & Co. . . . .	13
Tabor Mfg. Co. . . . .	4
Talmage Mfg. Co. . . . .	1
Unlwood, H. B., & Co. . . . .	13
Union Pacific R. R. . . . .	7
Union Switch & Signal Co. . . . .	395
United States Metallic Packing Co. . . . .	23
Utica Steam Gauge Co. . . . .	25
Vacuum Cleaner Co. . . . .	13
Van Duzen Co. . . . .	25
Vulcan Iron Works. . . . .	10
Walworth Mfg. Co. . . . .	2d Cover
Washington Co. . . . .	396
Watson-Stillman Co. . . . .	4th Cover
Westinghouse Air-Brake Co. . . . .	6
Westinghouse Electric & Mfg. Co. . . . .	7
Whiting Foundry Equipment Co. . . . .	32
Whitley, Geo. P. . . . .	349
Williams Typewriter Co. . . . .	14
Wood, R. D., & Co. . . . .	7
Zephon Chemical Compound Co. . . . .	15

# Railway and Locomotive Engineering

Copyright by Angus Sinclair Co.—1906

A Practical Journal of Railway Motive Power and Rolling Stock

Vol. XIX.

136 Liberty Street, New York, September, 1906

No. 9

## Bascule Bridges.

In what are called the middle ages one must look for probably the first example of the movable bridge. In those days when the baron in his stronghold, surrounded by his retainers and his men-at-arms, was a power to be reckoned with, often to be pla-

placed. It spanned the moat, and it was hinged at the threshold of the castle entrance so that when lifted into a vertical position it would completely cover the doorway and cut off the castle from all communication with the outer world.

The castle drawbridge was therefore

of the doorway. They were carried over pulleys, below which, and inside the walls, the loose ends of the chains hung, and to these ends heavy masses of stone or iron were attached for the purpose of balancing the weight of the bridge, and of assisting those inside to raise it as occasion required.



DOUBLE ROLLER LIFT BRIDGE ON THE CHICAGO TERMINAL TRANSFER RAILROAD.

cated by the king or to be reduced to subjection by physical force. In times like those the barons' castle was a fortress and was built with the intention of being able to withstand a siege. It was generally composed of one or more massive stone towers surrounded on all sides by a huge ditch or moat, filled with water. At the main doorway the drawbridge was

a part of the scheme of fortification which was carried out in every detail of the building. The bridge, hinged at the castle end, rested on the far bank of the moat, when open for traffic, as we would say. To the outer end of the bridge a pair of chains were attached and these were carried up at an angle and passed in through openings in the castle walls about the height of the top

Sometimes two huge beams hung out from the walls over the edges of the bridge and from the beam ends, chains were attached to the outer end of the bridge. These beams rocked upon pivots placed in the openings in the walls, and the ends of the beams extended back inside the castle and were counter-weighted, to assist in raising the bridge. The old time castle draw-

bridge spanning the moat, and built for defensive purposes was nevertheless a bascule bridge within the ordinary meaning of that word. Bascule comes from a French word meaning to swing, or a balance.

The modern bascule bridge, like its medieval predecessor, is a balanced lift

two, heavy cast iron wheels each with two external flanges. They are arranged with removable metal discs for adjusting their weights. To the centers of these heavy wheels the drawbridge chains are attached, so that as the bridge is raised the counter-weights roll slowly down the inclined way, the double flanges on the counterweight wheels guiding them along rails as they descend.

The upper edge of the girder upon which the wheel-weights roll, is made in the form of a compensating-moment curve. Without going further into the geometrical properties of this curve, a glance at our illustration will make it apparent that when the bridge is down and in position for a train to pass over the bridge, the counter-weights are hanging almost vertically from the pulleys on top of the towers and they are therefore exerting their maximum pull on the cables when the weight of the bridge is evenly divided between the hinge and the abutment on the far shore. As the bridge rises the counter-weights travel along the surface of the curve, and as they proceed, the supporting edge of the girder becomes more and more nearly horizontal, and bears more and more of the weight of the rolling wheels and so

as the counter-weights roll down along its edge the pull on the bridge cables is as constantly reduced as the rotation of the bridge on its pivot, gradually transfers its weight to the hinge.

The compensation is so steadily produced and the balancing of the bridge is so good that it can be raised and lowered by hand power, and it cannot come up too fast or fall to the horizontal position. The bridge as a railway structure is protected by derails and signals, and forms a unique example of the bascule type of bridge suitable for the gap it spans. The lifting of the bridge gives an absolutely unobstructed waterway.

Perhaps the most modern example of the bascule bridge is that of the roller lift type, a photograph of which we have been able to reproduce as our frontispiece. It shows the double roller lift bridges over the Chicago river, built for the Chicago Terminal Transfer Railroad by the Pennsylvania Steel Company, to whom we are indebted for the photograph. This bridge consists of two roller spans, and a stationery or island span in the center, the whole being supported on seven piers, five of which are in the center. The bridge was designed and patented by the Scherzer Rolling Lift Bridge Company. We are indebted to Mr. J. O. Osgood, chief engineer of the C. R. R. of N. J. for information concerning the structure and for facilities in examining and photographing its parts.

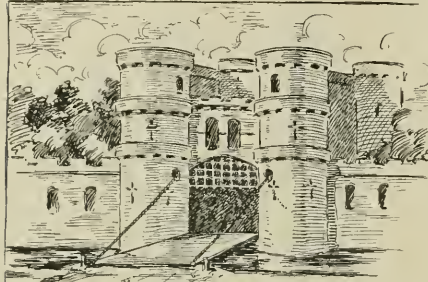

ANCIENT FORM OF DRAWBRIDGE OVER CASTLE MOAT.

bridge, but the balancing conforms to scientific principles, so that although the counter-weight for a bridge remains constant, the motion of the bridge up or down gradually alters the effect which the counter-weight produces. In the old castle drawbridge the counter-weights exerted a pull on the chains, somewhat less than what was required to raise the bridge, so that when it was down it would stay down. The angle at which the chains were carried up to the pulleys in the wall altered the effective pull on the bridge, and the projecting beam arrangement was practically an effort to secure somewhat better balancing. In either case, as the bridge began to rise and as more and more of its weight came upon the hinge, the effective pull of the counter-weights, at first too small, became too great, when the bridge came to the vertical position, and it is probable that the castle drawbridge began to rise very slowly and ended by slamming up against the door sides. The fact that there was a strong crossbarred frame of wood or iron called the portcullis which hung loosely like a window sash, in grooves formed in the walls of the doorway, renders it likely that castle men found the drawbridge at times too slow of motion. The portcullis being much heavier than its counter-weights could be quickly lowered in an emergency.

A good example of compensating counter-balance is shown in our illustration which is reproduced from a photograph of the bridge on the Greenwood Lake branch of the Erie railroad where the line passes over the Morris canal. This bridge is hinged at one end and the wire cables are carried up and pass over two pulleys mounted on the top of two lofty steel towers. The counter-weights are

gradually diminishes the pull upon the chains. When the bridge assumes the vertical position, and when its weight is almost entirely borne by the hinge, the traveling counter-weight has arrived at the most nearly level portion of the curve and at this point practically all its weight is carried by the girder, and very little by the bridge cables. The property of the curve is such that



ERIE LIFT BRIDGE, WITH COMPENSATING WEIGHT.

When in position for traffic each of the roller spans forms an ordinary bridge girder supported at each end. The rail joints at both ends are beveled and the rails are spiked to the bridge ties all along. Expansion and contraction are thus provided for without the use of shifting or loose rail ends, and the alignment of the track is not in any way deranged by the movement of the

bridge. There is a double track and trains of the C. R. R. of N. J., the Philadelphia & Reading and the Baltimore & Ohio pass over it at high speed. The operator's tower is in the center mounted upon a strongly built and braced steel tower and two 75 h.p. gasolene engines made by Fairbanks Morse & Company supply the power to move the spans. Speaking of one of the spans one may say that it rolls upon two heavy solid horizontal steel girders having wide flat tops. These girders are provided with a number of flat,

of a circle of 24 ft. 6 ins. radius, and the pin-end of the rack is fastened in line with the center from which this arc is struck, so that in moving the bridge, the rack is carried backward in a horizontal line. The span is 120 ft. center to center of piers and the weight of the counter-balance is about 521,000 lbs. on each side, or a total of about 1,042,000 lbs. The bridge itself, that is each girder, weighs in the neighborhood of 798,000 lbs. and the excess of counter-balance is necessary as the weight on the heel of the

power and saving of time, become easily apparent.

The roller bridge on the Central Railroad of New Jersey is protected

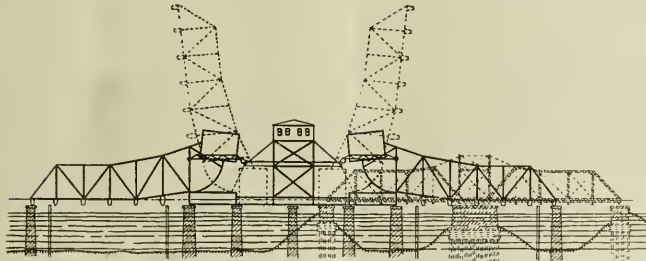

SKELETON SKETCH OF C. R. R. OF N. J. ROLLER LIFT BRIDGE SHOWING POSITION OF FORMER SWING SPAN.

round and slightly conical studs bolted to the top of the girders, and as the curved surface of the bridge end rolls upon the girder, the studs engage with corresponding depressions in the underside of the rollers, like the teeth of a rack in a gear wheel, and this has the effect of preventing any creeping action of the girders as they are swung up or down. The whole span is counter-weighted by a number of solid cast iron blocks, bolted back to back to a centerplate or web and looking when in place like the squares of a huge checker board. The total weight for each span is about 521,000 lbs. and when the bridge is in position for traffic the weights are about level with the operator's tower, and on top of the heel of the roller. The tower has to take care of the pull of the bridge when it is being raised or lowered.

The movement of the bridge is effected by the operation of a suitable train of gear wheels which terminates in a large spur wheel, which engages with the teeth of a rack. The rack is secured to a cross beam of the bridge, or more correctly to the operating strut, by means of a pin connection which allows the bridge to roll up or down, and adjusts itself for any movement of the beam to which it is attached. The rack is stiffened by four heavy girders of channel section and a strap with a pair of rollers on top, keeps the rack and spur wheel in constant and uniform contact. The heel of the bridge girder is the arc

bridge acts upon the short arm of the lever while the weight of the bridge acts on the long arm. The movement up and down is thus secured with a comparatively small expenditure of power. When, to this is added the fact that the roller type of bridge when fully raised affords a completely unobstructed channel for the passage of

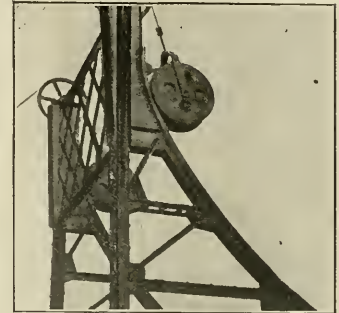

COMPENSATING WEIGHTS ON ERIE LIFT BRIDGE.

in the most approved style. A complete electro-pneumatic interlocking plant is in operation, the signal tower being on one side and below the bridge operating tower.

The approach of a train becomes known in the signal tower by the change of color of a small disc in an indicator box, and this takes place when the approaching train is two blocks away. If the home signals show clear the train can come on at high speed and cross the bridge without danger. If the route is set for railway traffic and it becomes necessary to open one



TRAIN PASSING THROUGH ROLLER BRIDGE, C. R. R. OF N. J.

ships no matter how high their masts may be, and that for perhaps 80 per cent. of the water traffic, the bridge need only be raised a short distance, its advantages in point of economy of

or both of the spans for a ship, the signal man is compelled by the interlocking mechanism to perform the necessary acts in a certain definite order, the sequence of which he is powerless to

vary and the indication given by the signals never can be a wrong one.

There are two navigation semaphore signals on top of engine house that indicate to approaching boats which leave of draw will be raised when conditions of train traffic permit. In other words, these signals do not give boats the right to proceed, but indicate for which channel boats must arrange their course.

To let a ship through the channel, the signal man's first operation is to set at danger the home signals which protect the bridge, and the distant signals belonging to these homes at once give the caution indication. All these signals must act in this way before it is possible for him to make the next move. He then opens the derrails and next unlocks the rails on the bridge from those on shore, and this is followed by the act of releasing the hooks which hold the bridge girders locked to the abutments. The final act

simple throwing of a lever is sufficient to constitute the finished act. Lever movement must in each case be succeeded by the actual alteration of the signal, or the movement of the bolt or whatever it may be; but in all cases the successful performance of the necessary and vital mechanical act is what unlocks the mechanism for the next movement. The absolute dependence of effect upon cause is nowhere better exemplified than in a modern interlocking signal installation. In order to resume railroad traffic after the bridge is again down in place the reverse order of acts, beginning with the locking up of the gear-lever in the engine room, and ending with the clearing of the home signals and the consequent dropping of the distant blades, must be observed, and no other combination or sequence of events will produce the desired result.

The signals, derrails, as well as bridge and rail locks are operated by compressed air, drawn from the pipe which supplies all the pneumatic signals along the road between Jersey City and Bound Brook. At the bridge, however, the pipe line dips under the water and comes up on the "island" where the interlocking tower is placed. The engine room is supplied with an auxiliary air compressor, which is used in starting the bridge hoisting engines. In case of accident to the signal air pipe line anywhere away from the bridge, the signals and locking mechanism may still be operated by taking air from the auxiliary compressor on the bridge.

Each roller span is provided on each

efficiency of operation are here linked with the highest degree of safety, and as the trains rush over the bridge or as the ships pass through between the



INTERIOR VIEW, BRIDGE PARTLY RAISED.

uplifted girders, each waiting, when occasion demands, with intelligent understanding for the other: one sees behind it all the triumph of the intellect and the reward of skill. Man is at his best when he works with brain and hand.

#### Value of Friction Draw Gear.

In addressing the Central Railway Club a short time ago, Mr. W. O. Thompson gave them this as an example: Take a loaded car weighing 90-

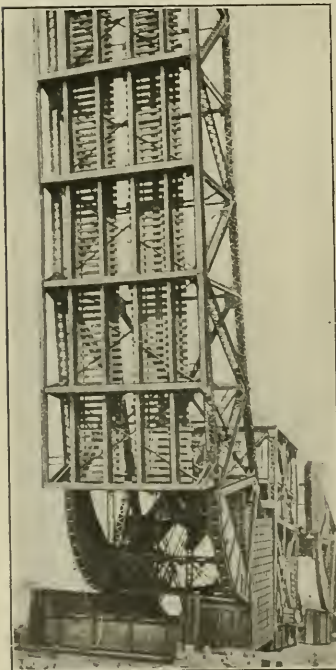

ROLLER BRIDGE WITH ONE SPAN FULLY RAISED, SHOWING POSITION OF COUNTERWEIGHTS.

is to unlock the lever in the engine room which controls the lifting mechanism and to signal the man in charge to lift the bridge. Not only is this precise sequence of events obligatory, but the completion of each act is necessary before the next can be performed. This does not mean that the

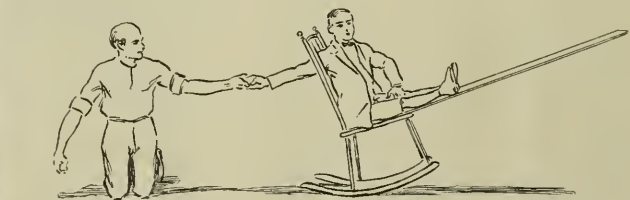

PRINCIPLE OF THE ROLLER LIFT BRIDGE. THE MAN ON THE FLOOR SUPPLIES THE POWER AND THE BOY ON THE CHAIR REPRESENTS THE ROLLER SPAN.

side, and near the shore ends with a revolving light which shows red, up and down stream, for all angles of lift short of the full opening. When the bridge is open as far as it can go, a green light shines out over the water. The red light not only indicates that the bridge is open a certain distance, but it gives the head room for the time being, so that those on board ship may govern themselves accordingly.

The whole system has been carefully devised for the purpose of eliminating all uncertainty and the chances of human failure or neglect. Economy and

oo0 lbs., moving at the rate of 4 miles per hour stopped by a standing car of equal weight, brakes not set. The energy of a moving body is equal to half its mass multiplied by the square of the velocity. In this case it amounts to about 48,000 ft.-lbs. This is the energy to be dissipated, and it is equal to a ton weight falling 24 ft.

The cushion value of a draw spring is about one-half its total capacity into its movement, which, for a 19,000 lb. spring is 1,583 ft.-lbs. We have one spring on each car, giving a total in the two gears of 3,166 ft.-lbs. of cushion resistance. The springs act to move the



standing car and stop the moving one and the energy stored in the compressed spring acting to stop the moving car amounts to 3,166 lbs., gives a total of 6,332 ft.-lbs., or about one-eighth of the amount required. The other seven-eighths is delivered in the form of a severe shock, which does damage to

It was difficult to make satisfactory comparison on the data afforded by a few trips, but yard tests made on the same trains demonstrated the value of the increased resistance obtained with the friction gear. The trains equipped with the spring gears were broken in two repeatedly, under conditions that

it is believed that the tensile strains in draw gears will frequently reach, even with careful handling, 50,000 lbs.; with ordinary handling, 80,000 lbs.; with decidedly rough handling, 100,000 lbs., while buffing strains can be placed between 100 and 300,000 lbs. In extreme cases the buffing strains will go considerably above the last named figure.

Concluding Mr. Thompson said, ultimate strength is a mere matter of metal and money and a low capacity gear can be so constructed that it will not break of itself, but the car must in some way dissipate the energy not transformed by the gear, and the result is in the end, a failure of the car structure. The approved friction gears seem to be the best form possible to take and transmit the strains put upon them, and they deliver the stresses to the car in a mechanical manner. They meet fairly all the requirements called for, especially those most important of all points—high cushion capacity, low recoil, high ultimate strength, low cost and standard dimensions. If more is wanted we must spend more money and have more room.

Never before in the history of the London & Southwestern Railway have so many passengers traveled to Royal Ascot by the company's special trains. Such a tremendous demand was there on the rolling stock that the London & Southwestern Railway actually had to

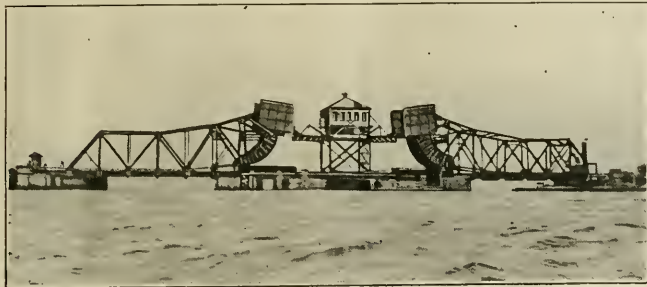

DOWN STREAM VIEW OF ROLLER LIFT BRIDGE OVER NEWARK BAY, N. J.

both cars, shifts the load and subjects the structure of the car to enormous stresses.

Mr. Thompson elucidates his figures in another example where an empty car, 35,000 lbs., moving at the rate of 7 miles an hour, is brought to rest by what may be called a collision with an empty standing car of equal weight with brakes not set. This car if suddenly retarded, would have energy equal to 57,283 ft.-lbs. The spring gear is supposed to have 40,000 lbs. capacity. The absorbing value of this gear used in this way is about 38,000 lbs. This amount is multiplied by 2, for the two gears, multiplied by 2 ins. for the movement, divided by 2 to get the mean effective resistance and divided by 12 to obtain foot-pounds and multiplied by 2, because the standing car can move away from the blow during compression of the spring, this equals 12,666 ft.-lbs. of effective resistance. This is about one-quarter of the amount required and the shock not taken up by the draw gear is very effective in its destructive action and is felt in every fiber of the car from roof to trucks.

Suppose the car was equipped with 60,000 lb. gears, they would only be a little better off. Such a gear would have cushioned 20,000 lbs. out of the 57,280 to be dissipated. Dealing with friction draw gear the speaker referred to some tests made on the Lake Shore & Michigan Southern. The chief object of the tests was to ascertain the magnitude of the strains caused in ordinary service. During the tests some experimental trips were made with solid trains of steel cars loaded with coal and equipped with twin spring draw gear and an equal number of trips were made with cars equipped with friction draw gear.

resulted in no damage whatever to the cars equipped with friction gear.

One fact developed in these tests was that the most ordinary movement in coupling up engines and cars, even if performed with care, resulted in heavy buffing shocks. An engine coupling to its train causes stresses ranging from 65,000 to over 142,000 lbs. A switch engine coupling on to the dynamometer car, standing alone, gave a stress of 103,-



EXAMPLE OF SWING BRIDGE SHOWING TURNTABLE AND CENTER PIER. BRIDGE MUST OPEN FULLY FOR EVERY VESSEL

673 lbs. When a string of loads was behind this car the buffing shock amounted to 199,482 lbs. It was found that thirty loaded cars moving six and a half miles an hour coupling to ten loads with brakes set, gave a shock of 376,492 lbs. From the general results of the tests,

borrow railway carriages from the Great Western Railway, the Great Central Railway, the London & Northwestern Railway, the Southeastern & Chatham Railway, the London, Brighton & South Coast Railway, the Great Northern Railway and the Midland Ry.—N. Y. Globe.

### Concentration of Power.

The gas engine has lent itself with extraordinary utility for concentrating great power in small space to propel with amazing speed light vehicles, but when immense power is required to propel huge vessels the steam engine still holds its own. The world is about to see the greatest aggregation of power ever concentrated upon the driving of one vessel. This is in the monster Cunard steamer "Lusitania," launched last month from the ship-building yards of Messrs. John Brown & Co. on the river Clyde, Glasgow, Scotland. It is the largest ship in the world.

The "Lusitania" is 790 feet long, a size difficult to grasp, but it is as long as a train of twelve Pullman palace cars, and the depth is 60 feet 6 inches, equal to the height of an ordinary sleeper stood on end. The power is provided by six turbines, four for working ahead, and two for backing. Those for driving the vessel forward are capable of developing between 70,000 and 80,000 indicated horse power. There are 192 furnaces for generating the immense volume of steam required. If one hundred of our most powerful locomotives were coupled to a full train, they would not develop more power than the engines of this monster ship.

When the engines of this vessel are working at their maximum power, it

produced by about 1.25 pounds of coal.

The delay in making transatlantic trading a success for steamboats did not arise for want of effort or agitation in its favor. In 1819, the American steamer "Savannah" made a voyage from Savannah, Ga., to St. Petersburg



ARMORED RAILROAD TRAIN.

via Great Britain; but sails did more of the propulsion than steam. Other long voyages were made by steam ships with sails doing a large share of the driving.

It was not till 1838 that really steam propelled steamers successfully crossed the Atlantic. In that year the "Sirius," a ship of 700 tons and of 250 horse power, and the "Great Western," of 1,340 tons and 450 horse power both crossed the Atlantic at the same time. The "Sirius" steamed from "Cork, Ireland, April 4 1838, and the

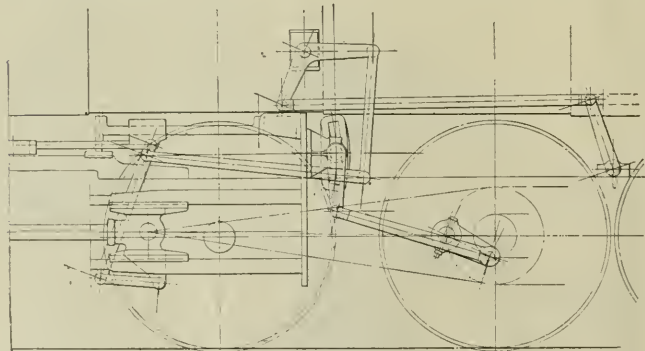

ARRANGEMENT OF WALSCHAERTS VALVE GEAR, G. N. RY.

will require about 50 tons of coal an hour to keep up steam.

This latest triumph of the ship builders' art is the consummation of progress that moved slowly until within the last twenty years. Long after steamers were working on the American lakes and great rivers, the engineering world doubted the practicability of a vessel steaming across the Atlantic. Before 1840, it required about 7 or 8 pounds of coal per horse power per hour for the best marine engines, while now the same unit of power is

"Great Western" from Bristol, April 8. Both vessels reached New York harbor on the same day.

It was a small beginning, but it has brought forth great achievements.

### Good Record.

The Pittsburgh & Lake Erie has met the record of the Michigan Central by showing that it has not killed a passenger in 28 years, and that it has a greater density of traffic.—N. Y. Commercial.

### Mechanical Fallacy.

The persevering inventor who labors persistently to make railroad officers take stock in a mechanical fallacy is not confined to America, although his name is legion here, as most railroad men can testify. Some time ago there was an inventor in France who believed that train resistance could be greatly reduced by increasing the size of wheels, and he labored for years to convince railway officials that his theories were correct. Being a man of means, he had a locomotive and train of cars built embodying his ideas. The locomotive had three pairs of coupled wheels 8 ft. 2½ ins. in diameter, cylinders 19x28 ins., and the engine in working order weighed 45 tons. The cars were carried by four wheels of the same diameter as the locomotive drivers, the total rigid wheel base of each being 15 ft. The great height of axles and wheels necessitated a peculiar construction of car, and he arranged the seats in two stories. There were lower compartments at the ends and between the wheels and an upper compartment reached by outer staircases. It took some courage to ride on this train at high speeds. Independently of the danger arising from the high center of gravity, combined with the long, rigid wheel base, the inventor evidently mistook the nature of the obstacles to high speed, among which axle friction cannot be reckoned. The power required to overcome this increases in the simple ratio of the speed, while the air and other resistances increase as the square or cube of the velocity. Although the power required increases, the work consumed in axle friction does not; for a given distance, the axle makes the same number of revolutions whether the train moves slowly or quickly, and if the steam is as economically got up and used in one case as the other, the portion of the cost falling upon the axle friction is the same in both cases. If there were no other resistances, high speeds would be more economical than low ones, as the plant would be better utilized; but, practically, the reverse is the case.

### Underestimating Locomotives.

Many mechanical engineers of spotless reputation and known to possess considerable professional ability, sometimes display lamentable ignorance of the work done by locomotive engines, and at what expenditure of steam the work is performed. The tendency of late years has run so strongly towards subdividing engineering into specialties, that being ignorant of any branch of the profession entails no discredit; but when an engineer uses his professional standing as an assurance and guarantee that he is a reliable authority, and under that pretense gives opinions on matters he

knows nothing about, he is guilty of a most reprehensible act.

The engineering world, interested in giving opinions about the locomotive, and the financial world, liable to invest in schemes for the improvement of the engine, ought to know that a well-built, properly managed locomotive is a more economical steam user than many ordinary stationary engines, and that high-class automatic or condensing engines display a very small margin of economy over a good locomotive. An engine of this kind running a passenger train that can be handled easily does the work on an expenditure of about 20 lbs. of steam per horse power per hour. The ordinary freight engine will use double or treble that amount of steam for the simple reason that freight locomotives are habitually overloaded and must let the steam follow the piston so far at full pressure that the terminal pressure is necessarily very high. Passenger lo-

comotives with which it is hard to make running time and which have to be forced rapidly into speed after frequent stoppages, will use nearly as much steam per horse power as the freight engine. The fact that a locomotive is using twice the steam which ought to be required in order to do the work, is really no reflection upon the engine, but generally is the fault of overloading, a condition that will deprive any class of steam engines of an economical record.

on a trunnion, whose bearing is bolted to the guide yoke. The trunnion has an arm at its outer end, and to this arm the eccentric rod is coupled. The combination lever is placed inside the guides. The radius rod is therefore extended back of the link in order to meet the lifting hanger, by means of which the link block is raised or lowered in the link. The driving wheels of this engine are 69 ins. in diameter and with 210 lbs. boiler pressure, the calculated tractive effort is about 37,550 lbs. and the factor of adhesion is 4.06. All the wheels are flanged and the overhung spring principle is carried out for the driving wheels. The engine truck and the front pair of drivers are of course equalized together, and the main and rear drivers are equalized together and with the trailing truck. The location of the headlight is peculiar, the bracket being bolted to the smoke-box door. The injectors are placed on the back head and

heating surface of 1 to 65. The tubes are 301 in number, having an outside diameter of 2 $\frac{3}{4}$  ins. and each is 18 ft. 6 ins. long. The tube heating surface is 3,205 sq. ft., leaving 206 sq. ft. in the fire box. The staying of the Belpaire fire box is of course by 1 in. direct bolts. There are two rows of sling stays at the front end of the fire box adjacent to the tube sheet.

The tender is made with a steel frame and is carried on two archbar trucks. The tank has a water bottom and altogether holds 8,000 U. S. gallons of water. The fuel space is provided with a bulkhead front and back, and the coping is curved inward over the coal space in order to prevent any of the fuel falling off. The engine itself in working order weighs 209,000 lbs. and with the tender the combined weight amounts to about 360,000 lbs. Some of the principal dimensions are subjoined for reference:

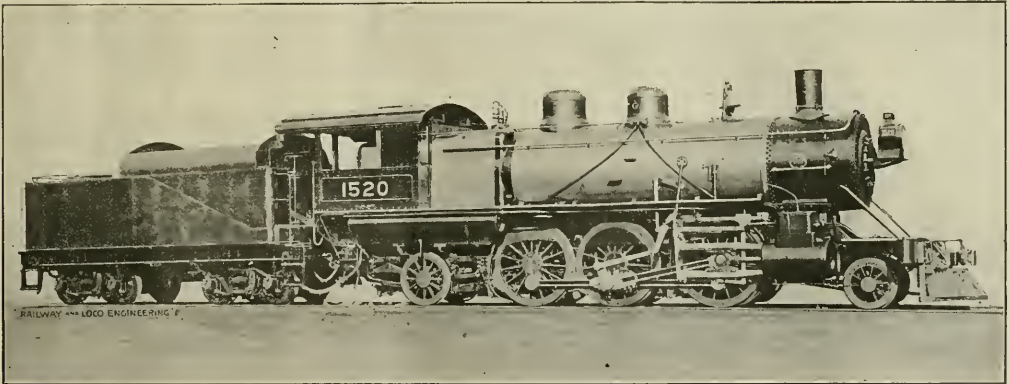

FAST FREIGHT 2-6-2 FOR THE GREAT NORTHERN RAILWAY LINE.

G. H. Emerson, Supt. of Motive Power.

Baldwin Locomotive Works, Builders.

comotives with which it is hard to make running time and which have to be forced rapidly into speed after frequent stoppages, will use nearly as much steam per horse power as the freight engine. The fact that a locomotive is using twice the steam which ought to be required in order to do the work, is really no reflection upon the engine, but generally is the fault of overloading, a condition that will deprive any class of steam engines of an economical record.

#### 2-6-2 Type for the Great Northern.

Fifty Prairie or 2-6-2 type locomotives, designed for freight service, have recently been built by the Baldwin Locomotive Works for the Great Northern Railway. The cylinders are single expansion, 22x30 ins. with balanced slide valves, and the valve motion is of the Walschaerts type. The link is carried

feed through external pipes, the check valves being placed right and left, and about in the center of the first course. The reach rod has a joint in it over the space between the main and rear drivers and it is here carried on a supporting arm and bracket.

The boiler has a wide fire box of the Belpaire type, with sloping throat and a straight back head. The longitudinal seams of the boiler barrel are located on the top center line and are welded at each end, the Vaulchain diamond weld strip being used in each case. The roof sheet and the fire box casing sheets are made of three separate plates with a 14-in. flat, lap seam, in which are screwed the ends of the cross braces above the crown sheet. The fire box is 116 $\frac{1}{2}$  ins. long by 66 $\frac{1}{2}$  ins. wide, which gives a grate area of 53.4 sq. ft. The total heating surface is 3,471 sq. ft., which gives a ratio of grate area to

Boiler—Type, Belpaire; diameter, 72 ins.; thickness of sheets,  $\frac{3}{8}$  and 21/32 ins.; working pressure, 210 lbs.; fuel, soft coal; staying, vertical.

Fire Box—Material, steel; length, 116 $\frac{1}{2}$  ins.; width, 66 $\frac{1}{2}$  ins.; depth, front, 72 ins.; back, 64 ins.; thickness of sheets, sides,  $\frac{3}{8}$  in.; back,  $\frac{3}{8}$  in.; crown,  $\frac{3}{8}$  in.; tube,  $\frac{1}{2}$  in.; water space, front, 5 ins.; sides, 5 ins.; back, 5 ins.

Tubes—Material, steel, wire gauge No. 11.

Driving Wheels—Journals, 9 $\frac{1}{2}$ x12 ins.

Engine Truck Wheels—Front, diameter, 36 ins.; journals, 6x12 ins.; back, diameter, 45 ins.; journals, 8x12 ins.

Wheel Base—Driving, 13 ft.; total engine, 30 ft. 9 ins.; total engine and tender, 63 ft. 8 ins.

Weight—On driving wheels, estimated, 151,000 lbs.; on truck, front, 21,000 lbs.; on truck, back, 37,000 lbs.

Tender—Wheels, 36 ins.; journals, 5 $\frac{1}{2}$ x10 ins. Service—Freight.

The Emperor William in his automobile has raced with and beaten the Kiel express. He went 75 miles in 99 minutes.—World Wide.

### Crank Axles.

The crank axle, like the compound locomotive, was in use in Europe long before it was adopted in this country, and for a time American railroad men very much doubted the reliability of crank axle. A form of axle having a Z-shaped central portion was used for the crank axle the New York Central engine, built by the American Locomotive works, and shown at the St. Louis exhibition. The axle weighed 3,200 lbs. and was made at the Krupp works in Germany. This consisted of 7 pieces and was a built up axle.

A crank axle designed by Mr. Worsdell, locomotive superintendent of the North-Eastern Railway, has been taken as a basis of design for a number of engines in this country. The Worsdell type of axle was forged solid and had two discs, one on each side of the cranks, or four discs in all. These discs were for the purpose of counterbalancing. It was a Z-shaped axle, and the design derived

outside crank pins being balanced in the wheels, which much reduces the weights applied to the drivers.

The axle shown in our illustration is used in the Baldwin engine built for the Union Pacific and which was illustrated and described in the August issue of RAILWAY AND LOCOMOTIVE ENGINEERING, page 387. This is a built up axle made of 7 parts and having two circular balancing discs, which unite the axle ends and the crank pins. The central web is of approximately rectangular section and is a separate piece. The axle has the advantage of

beams upon the Tropic of Cancer, but he did not wish to have words like those even in his thoughts when the fishing was good and swimming had been extra doubly prohibited, and must, therefore, be enjoyed in moderation.

He did not take in all the teacher told the class about things in general and why everything happened, but he had taken great interest in observing that the ends of the rails which his father and "the men" worked with had round-ended oblong holes for the joint bolts. When the teacher asked him in school for his official explanation of why the

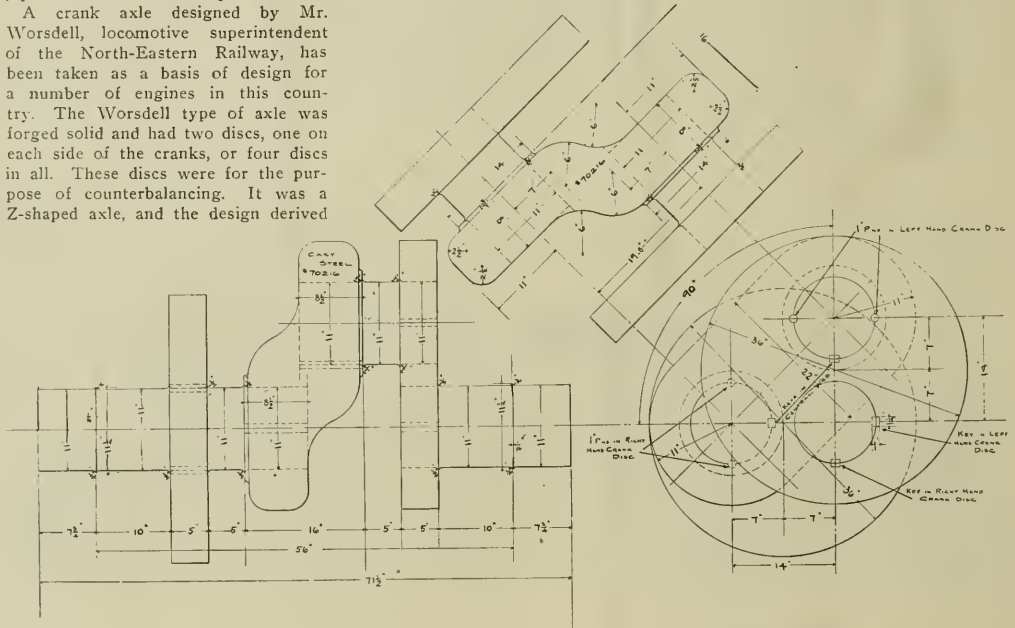

CRANK AXLE OF UNION PACIFIC 4-4-2 ENGINE. IT IS MADE IN SEVEN PIECES.

from it was also a solid forging, but omitted the two inner discs, and substituted a rectangular bar for the connection between the cranks. This style of crank axle can be used with advantage where the central portion of the axle does not carry the eccentrics.

A crank axle designed by Mr. Wm. Drummond, of the London and South-Western railway, consists of a modification of the discs, of which, like the Worsdell axle there are four, in which the discs are flattened to something of a triangular shape with the smaller ends containing the crank pins, and the heavier outer portions acting as counterbalances. This axle is made of 9 parts and is of the built-up type.

The advantages of the built up type of crank axle are that the revolving and reciprocating parts can all be balanced in the axles, the side rods and

being balanced close to the planes in which the disturbance caused by the reciprocating parts acts, and so relieves the wheels of these stresses.

The crank axle has given every satisfaction since its adoption in this country, and is now a recognized feature of many of our modern types of compound engines. The central heavy web of cast steel used on the Union Pacific, 4-4-2 engine to which we have referred is of course only possible where the crank axle does not carry eccentrics.

### Explanatory.

He was a section foreman's son and he had been forced to go to school when he had expressed his desire to be allowed to daily watch "the men" tamp the ties. In due course at school he heard about what happens when the sun reaches the summer solstice and pours its warm

days were longer in summer than they were in winter he forgot all about the solstice and the tropic and launched a theory of his own which, like all properly constructed hypotheses, accounts for all the facts and is contrary to none. He said: "When the summer comes and the sun shines hard all the time, the days get good and hot and expand, and that makes them long."

Plans for the James Watt Memorial Building at Greenock, Scotland, have been completed. The memorial will be a two-story building of dressed stone, designed in accordance with the domestic architecture of Watt's time, and will be on the site of Watt's cottage. A bronze statue of Watt will stand at the front corner. It is said that the building will cost about £7,000 and will have class rooms for instruction in navigation and marine engineering.

# General Correspondence.

## Hollow Staybolts.

Editor:

In the report on flexible staybolts, read at the Master Mechanics' Convention at Atlantic City, there were a few references to Hollow Staybolts which I think merit some attention. This report covered a single type of bolt, evidence had been sought on that type alone, and any reference to other types on which evidence had not been obtained was certainly irrelevant, unfair and uncalled for. Any erroneous or malicious statement is against the public interest, permit me therefore in justice to the makers of the Hollow Staybolts and the railroads of this country, to call attention to some of the statements of the writer of the report, and compare them with the cold facts of actual experience, and the record of actual service.

He says. "As the use of the tell-tale hole is a disputed practice, its action not being accepted as positive, and as it adds to the expense of application and maintenance, it is not to be recommended." I agree with the writer only in that statement, and let me say that while waiting for a train at Sunbury, Pa., I went into the shops there and was shown about a dozen bolts which had been taken out of an engine a few days before, they were broken and steam had failed to indicate failure, because the tell-tale holes were filled in part, with dirt, so hard that it felt like metal when I tried the holes. I have seen many other cases like this in different parts of the country, but I have never seen a Hollow Staybolt which was closed by dirt or sediment.

He speaks of the claims made for Hollow Staybolts, viz.: Better combustion, and absolute indication of failure of the stay, and casts them aside with the remark that these claims are "not proven." The writer of the report certainly shows unexpected hardihood, and simply thrusts his "not proven" against both facts in science and the cold stern facts of actual service, not service of a few years, but the service of from ten to twenty-five years. It would seem that his "not proven" will be jolted.

Quite recently the fire box of a switching engine on the Lake Shore & Michigan Southern Railway was removed. It was built in Schenectady, in 1892, Mr. Fred Lippert examined the Hollow bolts with which it was stayed, and "found the holes in all the bolts free from sediment, scale or

dirt"—14 years' proof that the Hollow bolts were absolutely reliable detectors. This engine carried 150 lbs. pressure. Every student of combustion knows that it is desirable to admit air in well distributed quantities among the gases. When we do this the gas is burned, when we do not do so the gas becomes black smoke and heat is lost.

Before the Hollow Staybolts became a "fait accompli," about eighteen years ago, there had been installations of hollow material for the purpose of bettering combustion. I have seen within a year some of the old engines that re-

change until 1905, when a new fire box was installed; the Texas & Pacific Railway has been saving money in bettered combustion by air through Hollow Staybolts for over ten years; the International & Great Northern Railway has been saving money in bettered combustion by air through Hollow Staybolts since 1892; the Canadian Pacific Railway and other railways, East, West, North and South, and in foreign countries, have had experiences which refute the "not proven" of the writer of the report.

And now, as all other bolts are solid

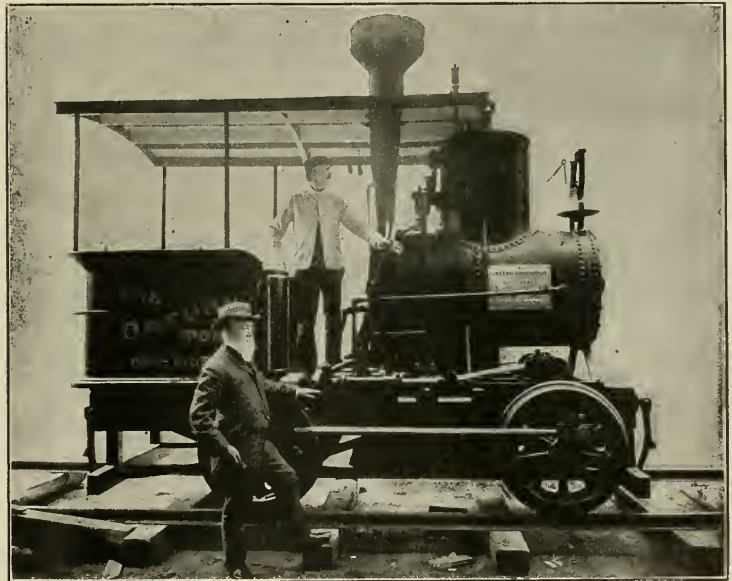

(Courtesy of the Sunset Magazine.)

### FIRST OREGON LOCOMOTIVE.

Locomotive presented to the State of Oregon by David Hewes of San Francisco, who is represented as standing beside it. The engine is a souvenir of the early commerce developed by the Oregon Steamship Navigation Company.

ceived those installations to better combustion, they have been in service since, on The Southern Railway, Engine 1884, built in 1881 with Hollow Staybolts on each side of the fire box. The Boston & Maine Railway, two engines in 1883 and one in 1888 with Hollow Staybolts on each side of the fire box. The Pittsburgh, Shawmut & Northern Railway, four engines built in 1890, stayed with Falls Hollow Staybolt Iron and in service since; the Long Island Railway, ten engines stayed, over 10 years ago with Hollow Staybolt Iron, in service since, without

and he does not approve of the tell-tale hole (nor do I) where, except in the Hollow Staybolt, can he get a bolt of any description that will "absolutely indicate failure," and what bolt, save the Hollow Staybolt, can be utilized to better combustion? The man who tears down a useful article should have something better to take its place, if not he is an enemy to progress. The writer of that report has found nothing better to take the place of the Hollow Staybolt. A studious reading of his own report will show that as an alternative deduction, and his evidence

otherwise, proves his conclusions inconsistent and erroneous.

I saw in the testing room of one of the large railways in the South, samples of broken solid staybolts, which had been coated with impurities from the water, preventing the conduction of the heat from the bolt to the water.

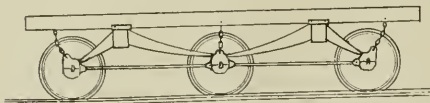

FIG. 5. SPRING ARRANGEMENT OF "NORRIS" SIX-WHEEL TENDERS.

(See page 365, August issue.)

The ends of the bolts when coated had commenced to burn, and the burning had continued along the line of the fibers until the steam pressure between the inner and outer sheets pressed the inner sheet out over the bolt heads. The bolts for about half their length were reduced in diameter, the threads were gone, and the diameter was smallest just inside the inner sheet; a part of the coating had dropped off the other half of the bolt, allowing the water to get to it, and that half of the bolt with its threads was uninjured. Those were dangerous conditions which the writer of that report would promote, and which could not have occurred if the Hollow Staybolt had been in use, owing to the passage of air through them.

The outlay by railways for weekly or monthly tests with a hammer to discover by sound the broken staybolts is large—and an uncertain costly way by which to discover breakages. Tell-tale holes add more to the cost of examination. The drilling of tell-tale holes in the ends is a disputed good, in my opinion a substantial evil, whereas there is a warning at either end of every Hollow Staybolt in the fire box to report breakages when breakages occur, without the touch of a hammer or the cost of a cent, and without risk of a lawsuit, such as related in the following:

"We had an explosion."—"What, I said, was the cause?"—"Oh, the witnesses swore the examination was imperfect."—"What examination?"—"An examination of the Staybolts."—"Was the explosion caused by broken Staybolts?"—"Yes."—"And what was the result of the suit?"—"Oh, there was a verdict against us for \$10,000."—"And what was the brand of iron in the Staybolts?"—"It was the . . . . iron."—"What an awful price, I said, to pay for . . . . iron."

In contrast to that experience, I

was in conversation, at the Convention, with a Superintendent of Motive Power, having 350 to 400 locomotives, a constant user of Hollow Staybolts for over ten years. He said he had no anxieties about breaking staybolts, for when they break they made the breakage known. No examinations

are necessary, for the holes are always open, and exultantly he said he was able to keep 97 per cent. of his engines in service. His savings in respect to examinations alone amount to \$25.00 to \$35.00 a day. That man had no fear of having \$10,000 to pay for damages by reason of explosions.

He had no grief to trouble his thoughts about a widow and fatherless children with their bread winner sacrificed to "imperfect examinations." He did not depend on fallible man, he depended on the hole through the center of the bolt.

JOHN LIVINGSTONE.

Montreal, Que.

#### Wear of Eccentrics.

Editor:

Your Pottsville correspondent's ground is well taken in regard to the wear of eccentrics at the thinnest part. The writer's experience in truing up worn eccentrics, was to put in centers and get the original throw, then strike a circle to set them by in the lathe, and I always had to turn off the belly of the eccentric to get them round and I have turned lots of them. If we set an eccentric in the lathe for the purpose of truing up the wearing surface and spot it around to get it true and regardless of the original throw, the chances are that the throw has been increased when the job is done; and it is barely possible that where this way of truing up eccentrics if followed, will be found the cause of trouble in getting engines square. Do I hear some one say that a foreman who knows his business would not do work that way? Yes, but there are lots of machine foremen who don't know.

W. DE SANNO.

Los Angeles, Cal.

#### Position of Eccentrics.

Editor:

After reading your article "Wise Eyes are Odd," in the August issue I have been thinking it over and in my opinion the easiest way to memorize the positions of the eccentrics is to start with the English system, outside admission and direct motion, in which both eccentrics are in the quarter circles farthest from the crank.

Now if either the admission is

changed or the motion is changed, it brings the eccentrics into the quarters of the circle near the crank. If, however, both the valve and the motion are changed then, on the principle that "two negatives make a positive," the eccentrics remain as they were in the further quarters from the crank.

Your memory help is all right and somewhat amused me when I saw it.

READER.

Buffalo, N. Y.

#### Flue Setting Method

Editor:

With the advent of thick fluesheets in locomotive fire boxes. I would counterbore the fluesheet  $\frac{3}{8}$  of an inch larger than the diameter of the flue and one-eighth of an inch in depth in a half-inch fluesheet. If the fluesheet was over  $\frac{1}{2}$  an inch in thickness one might go a trifle deeper. This will protect the beading from the clinker and cinders which are continually showering against the fluesheet and beading, cutting, raising and destroying it. It will also keep a more uniform heat on the beading, as the flame that strikes the fluesheet under the present system has to double back over the beading before entering the flue. The clinker and cinders also get under the beading whenever the beading begins to leave the sheet. By setting the beading in a counterbore all this is avoided and the heat is more uniform, especially in the extremes, that is when an engine is working hard and when the firedoor is open to supply fuel.

I think the flame will also extend a little further into the flue, as it will enter in a solid body. Neither the flame nor the cold drafts will run around the recesses they would around the exposed beading. To set flues in this way a few things have to be observed: the projecting end of the flue has to be the exact length, so that it will not quite touch the side of the counterbore when finished. If it did touch it would crowd the flue away from the fluehole and destroy the efficiency of the expander. The outer tip of the beading tool must be thin enough so as not to come in contact with the counterbore, or that will crowd the flue away from the flue hole. I would say to those who may try it that they ought to take a piece of an

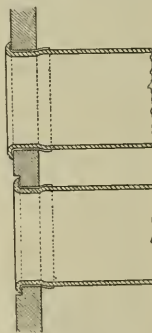

PROPOSED FLUE SETTING.

old fluesheet, first counterbore a few holes in that, and set a few short flue ends in it, so as to get the proper length of projection of flue and get bending tools right. I would also suggest that a little extra care be taken on the first set or two, until the flue-setters get acquainted with the work. I have never tried this system nor did I ever hear of anyone who had. The idea is original with me, but I think it will soon become general practice, if it turns out as well as I think it will, and I can see no reason why it should not. There is no patent on it, anyone is at liberty to use it. What is your opinion, and how do your readers view this suggestion? WM. SMITH.

Oak Park, Ill.

**Change Gears for Screw Cutting.**

Editor:

The selection of change gears for cutting screws on lathes does not appear to be well understood by most mechanics, and although there are many lathe men who can select simple gears, there are comparatively few who can select compound gears, un-



TURNED OVER.

less of very simple combination. Again, on some occasions it is found that the simplest combinations cannot be used on account of interference of a stud or other projection, or the swinging gear carrier will not move far enough without striking, or an essential gear may be broken; and another combination must be sought for; and the question then arises as to how many sets of gears or combinations can be found in the set provided which will cut the pitch of the thread required, so that each set may be tried to fulfil the particular conditions. It may be that the particular thread to be cut is a very odd one, so that it is doubtful whether there is any set of gears that will cut it, and some times hours are wasted in the effort to find such a set.

The object of this paper is to endeavor to reduce the subject to its simplest form, so that it may be useful to the average lathe hand.

The subject can be divided into two

clear and distinct operations, as follows: (1) to find the ratio of the screw required to the lead screw, (2) to find gears to suit that ratio. In the first place it is necessary that the number of threads per inch shall be discarded and the pitch always used thus: 3 threads per inch is  $\frac{1}{3}$ -in. pitch, 16 threads per in. is  $\frac{1}{16}$ -in. pitch, and  $11\frac{1}{2}$  threads per in. is  $1/11\frac{1}{2}$  or  $\frac{2}{23}$ -in. pitch and so on. Decimal pitches are treated as fractions, thus .27 pitch is  $\frac{27}{100}$ , and .035 is  $\frac{35}{1000}$ . Similarly the lead screw may be  $\frac{1}{4}$ -in. pitch (4 threads), or  $\frac{1}{2}$ -in. pitch (2 threads), e c. Then the ratio required is the ratio of the screw to be cut to the lead screw, and it is found by dividing the pitch to be cut by the lead screw pitch. Thus if we require to cut  $11\frac{1}{2}$  threads or  $\frac{2}{23}$ -in. pitch, and the lead screw is 4 threads of  $\frac{1}{4}$ -in. pitch, we divide  $\frac{2}{23}$ -in. by  $\frac{1}{4}$ -in., thus:

$$\frac{2}{23} \div \frac{1}{4} \text{ or } \frac{2}{23} \times 4 = \frac{8}{23}, \text{ the required ratio.}$$

Sometimes the lathe has permanent gearing between the spindle and the first gear stud, which has to be considered. For example, it was desired to cut some screws  $\frac{7}{8}$ -in. pitch, square thread, upon a lathe which had a lead screw of 3 threads per in. or  $\frac{1}{3}$ -in. pitch. It was found that there was a permanent gear from the spindle to the first gear stud of 30 to 40, which caused the stud to revolve only three revolutions to the spindle four revolutions. This is equivalent to having a lead screw of 4 threads per in. or  $\frac{1}{4}$ -in. pitch, as the lead screw is affected directly the same as the stud.

We then had  $\frac{7}{8}$ -in. pitch to cut from a lead screw of  $\frac{1}{4}$ -in. pitch, or  $\frac{7}{8}$ -in.  $\div \frac{1}{4} = \frac{7}{2} \times 4 = \frac{28}{2} = 14$  ratio of gearing, that is, say a 70 gear on the stud to a 20 gear on the lead screw or any equivalent ratio. The set of gears comprised 77, 70, 63, 56, 49, 42, 35, 28, 21, 20, and as the set of 70 and 20 were put on with any idler large enough, the proper thread was secured. It was found, however, that

$\frac{77}{70}$	$\frac{11}{10}$	$\frac{76}{73}$	$\frac{10}{9}$	$\frac{65}{60}$	$\frac{9}{8}$	$\frac{56}{49}$	$\frac{8}{7}$	$\frac{47}{42}$	$\frac{7}{6}$	$\frac{45}{35}$	$\frac{6}{5}$	$\frac{36}{28}$	$\frac{4}{7}$	$\frac{21}{20}$
$\frac{77}{73}$	$\frac{11}{9}$	$\frac{76}{70}$	$\frac{5}{4}$	$\frac{65}{49}$	$\frac{7}{7}$	$\frac{56}{42}$	$\frac{4}{3}$	$\frac{45}{35}$	$\frac{7}{5}$	$\frac{45}{30}$	$\frac{3}{2}$	$\frac{36}{21}$	$\frac{5}{7}$	$\frac{21}{15}$
$\frac{77}{70}$	$\frac{11}{8}$	$\frac{76}{49}$	$\frac{10}{7}$	$\frac{65}{42}$	$\frac{3}{2}$	$\frac{56}{35}$	$\frac{8}{5}$	$\frac{47}{20}$	$\frac{4}{4}$	$\frac{42}{21}$	$\frac{2}{2}$	$\frac{36}{20}$	$\frac{7}{4}$	$\frac{21}{14}$
$\frac{77}{49}$	$\frac{11}{7}$	$\frac{76}{42}$	$\frac{5}{3}$	$\frac{65}{35}$	$\frac{9}{5}$	$\frac{56}{28}$	$\frac{2}{2}$	$\frac{47}{21}$	$\frac{7}{3}$	$\frac{42}{20}$	$\frac{7}{2}$	$\frac{42}{20}$	$\frac{7}{10}$	$\frac{21}{10}$
$\frac{77}{42}$	$\frac{11}{6}$	$\frac{76}{35}$	$\frac{2}{2}$	$\frac{65}{28}$	$\frac{4}{4}$	$\frac{56}{21}$	$\frac{8}{3}$	$\frac{47}{15}$	$\frac{7}{2}$	$\frac{40}{20}$				
$\frac{77}{20}$	$\frac{11}{5}$	$\frac{76}{20}$	$\frac{5}{2}$	$\frac{65}{21}$	$1$	$\frac{56}{14}$	$\frac{11}{5}$							
$\frac{77}{20}$	$\frac{11}{4}$	$\frac{76}{21}$	$\frac{10}{3}$	$\frac{65}{20}$										
$\frac{77}{21}$	$\frac{11}{3}$	$\frac{76}{20}$	$\frac{7}{2}$											

the drive was very unsteady with only a 20 tooth gear to travel the carriage  $\frac{7}{8}$ -in. per revolution of the spindle, and it became necessary to try to find

a set of gears which would avoid the use of so small a gear as 20 or 21. The gears were therefore formed into a table of descending ratios, that is, the numerator of the fraction to be always larger than the denominator, or a larger gear to drive a smaller, thus:

Table of descending ratio of gears from 77 to 21 by a common difference



JURA-SIMPLON EXPRESS.

of 7 and one 20 gear. Ratios reduced to lowest form.

We now combine each of these ratios with every other ratio in the list to find a pair which will produce a ratio of  $\frac{7}{2}$ . Thus for instance commencing with the first ratio,  $\frac{11}{10}$ , we combine it with the next,  $\frac{11}{9}$ , thus:  $\frac{11}{10} \times \frac{11}{9} = \frac{121}{90}$  which is evidently not  $\frac{7}{2}$ , the ratio required. Proceed with the first ratio,  $\frac{11}{10}$ , all through the list. Unless forming a table (which will be mentioned later) we need only a few seconds' inspection of each; thus we see in the  $\frac{11}{10} \times \frac{11}{5} = \frac{121}{50}$ , the numerator is not a multiple of 7, which is the numerator of the ratio required, and it is then no use examining the denominator, so we can drop the combination of  $\frac{11}{10}$  with the first four columns and proceed to the fifth column where we find  $\frac{7}{6}$ . Then  $\frac{11}{10} \times \frac{7}{6} = \frac{77}{60}$  which is not equal to  $\frac{7}{2}$ . Similarly none of the other ratios combine with  $\frac{11}{10}$  to give  $\frac{7}{2}$ . This process has taken mentally about half a minute. Then discard  $\frac{11}{10}$ , and try the second,  $\frac{11}{9}$ ; for the above reason we only need test it with the fifth column and it does not work out to  $\frac{7}{2}$  with any ratio. Thus all the first column is quickly rejected.

We then start with the second column, thus:  $\frac{11}{9} \times \frac{7}{6} = \frac{77}{54}$ ,  $\frac{11}{9} \times \frac{10}{9} = \frac{110}{81}$  and so on until we come to the combination of  $\frac{7}{28}$  or  $\frac{2}{7} \times \frac{49}{35}$  or  $\frac{2}{5} = \frac{7}{25}$ . This however is only a variation of the last combination, the position of the 35 and 28 gears being changed. It is of value, however, as it sometimes occurs that other things interfere such as the swing of the gear carrier, etc. We also find  $\frac{2}{7} \times \frac{7}{4} = \frac{14}{28} = \frac{1}{2}$ , but this requires the use of two 28 gears.

It will be observed that we have only used the gears provided in descending ratio. This is caused by the pitch required,  $\frac{7}{8}$ -in. being much greater than the lead screw pitch  $\frac{1}{4}$ -in. If there is no great difference between the pitch required and the lead screw pitch it is necessary to go through all the above list, as in following table, thus:  $\frac{11}{10} \times \frac{21}{20} = \frac{231}{200}$ ,  $\frac{11}{10} \times \frac{1}{4} = \frac{11}{40}$ , the numerators not being multi-

$\frac{20}{21}$	$\frac{21}{20}$	$\frac{3}{4}$	$\frac{26}{37}$	$\frac{4}{5}$	$\frac{35}{47}$	$\frac{5}{6}$	$\frac{42}{79}$	$\frac{6}{7}$	$\frac{47}{86}$	$\frac{7}{8}$	$\frac{54}{83}$	$\frac{8}{9}$	$\frac{62}{70}$	$\frac{9}{10}$	$\frac{74}{77}$	$\frac{10}{11}$
$\frac{24}{25}$	$\frac{5}{7}$	$\frac{20}{37}$	$\frac{3}{5}$	$\frac{26}{47}$	$\frac{3}{5}$	$\frac{35}{79}$	$\frac{42}{86}$	$\frac{3}{4}$	$\frac{46}{83}$	$\frac{7}{9}$	$\frac{54}{70}$	$\frac{4}{5}$	$\frac{62}{77}$	$\frac{2}{11}$		
$\frac{28}{29}$	$\frac{4}{5}$	$\frac{21}{47}$	$\frac{1}{2}$	$\frac{26}{47}$	$\frac{4}{7}$	$\frac{35}{96}$	$\frac{42}{94}$	$\frac{3}{5}$	$\frac{47}{70}$	$\frac{7}{10}$	$\frac{54}{77}$	$\frac{8}{11}$				
$\frac{29}{32}$	$\frac{10}{21}$	$\frac{21}{47}$	$\frac{3}{7}$	$\frac{26}{57}$	$\frac{1}{2}$	$\frac{35}{95}$	$\frac{42}{95}$	$\frac{5}{9}$	$\frac{47}{77}$	$\frac{7}{11}$						
$\frac{20}{49}$	$\frac{21}{57}$	$\frac{3}{8}$	$\frac{27}{65}$	$\frac{4}{9}$	$\frac{37}{79}$	$\frac{1}{2}$	$\frac{42}{79}$	$\frac{6}{11}$								
$\frac{27}{26}$	$\frac{3}{14}$	$\frac{21}{65}$	$\frac{1}{5}$	$\frac{28}{76}$	$\frac{2}{5}$	$\frac{37}{77}$	$\frac{5}{11}$									
$\frac{23}{23}$	$\frac{21}{70}$	$\frac{3}{10}$	$\frac{28}{77}$	$\frac{4}{11}$												
$\frac{29}{70}$	$\frac{2}{7}$	$\frac{21}{77}$	$\frac{3}{11}$													
$\frac{27}{27}$																

ples of 7 which is the numerator of the required ratio, they are rejected, and so on through the whole of the two tables.

A full set of increasing and decreasing ratios may thus be combined as a permanent table of all the ratios that can possibly be formed with a given set of gears, that at any time if a particular ratio of gearing is desired it may be selected at once from the list, and in as many combinations as can possibly be formed from the set of gears given. If the ratio desired is not found in the list thus constructed, then the desired thread cannot be cut with that set of gears.

The following is a complete list of ratios formed by combining the first ratio of the first list,  $\frac{11}{10}$ , with every ratio following it (in both lists).

$\frac{11}{10}$	$\frac{121}{90}$	$\frac{11}{80}$	$\frac{99}{80}$	$\frac{44}{35}$	$\frac{77}{60}$	$\frac{33}{25}$	$\frac{11}{15}$	$\frac{22}{15}$	$\frac{231}{200}$
$\frac{121}{80}$	$\frac{11}{8}$	$\frac{99}{70}$	$\frac{32}{70}$	$\frac{77}{35}$	$\frac{20}{50}$	$\frac{11}{20}$	$\frac{6}{50}$	$\frac{77}{50}$	
$\frac{121}{70}$	$\frac{7}{5}$	$\frac{33}{20}$	$\frac{44}{35}$	$\frac{77}{44}$	$\frac{7}{40}$				
$\frac{121}{60}$	$\frac{11}{5}$	$\frac{99}{50}$	$\frac{11}{50}$	$\frac{77}{30}$	$\frac{231}{100}$				
$\frac{121}{50}$	$\frac{11}{4}$	$\frac{99}{40}$	$\frac{44}{15}$	$\frac{539}{200}$					
$\frac{121}{40}$	$\frac{11}{4}$	$\frac{33}{10}$	$\frac{77}{25}$						
$\frac{121}{30}$	$\frac{11}{3}$	$\frac{693}{200}$							
$\frac{847}{200}$	$\frac{77}{20}$								

COMBINATION WITH DESCENDING RATIOS.

The list of combinations for the next ratio,  $\frac{11}{9}$ , is then formed for all ratios following it and so on, each list being one less than the one preceding. It will be noticed that the same ratio is produced in different places which correspond to different sets of gears.

New York.

ROGER ATKINSON.

Adjustment of Tender Brakes.

Editor:

A poor and very unsatisfactory method of taking up tender brake slack, which is doubtless practiced to some extent, is lengthening the push rod and shortening the pull rods. The result is a change in the angularity of the levers rendering an indirect line of force through the brake gear and a cramped position of same. On some

occasions the brake cylinder levers will be found to strike their supports, or against the water scoop spring, if the tender has one, stopping their movement and the brakes are not applied with proper force, although the piston travel may indicate that they are. Repeated brake applications wear the brake shoes away from the wheels and produces slack and too long piston travel; naturally, this slack or too long piston travel should be taken up by bringing the shoes back to the wheels and the correct method of doing this is by means of the bottoms, rods and truck adjusters provided for this purpose. You may ask what is the trouble when the brake shoes have been brought as close to the wheels as proper shoe clearance will permit and still the piston travel is too long.

Generally that condition is due to worn pins and holes in the rods and levers comprising the brake gear, which can be remedied to the best advantage by replacing the worn parts with new.

WIRT D. SEELEY.

$\frac{22}{21}$	$\frac{33}{40}$	$\frac{22}{25}$	$\frac{11}{12}$	$\frac{33}{35}$	$\frac{77}{80}$	$\frac{44}{45}$	$\frac{99}{100}$
$\frac{11}{14}$	$\frac{33}{50}$	$\frac{11}{15}$	$\frac{14}{40}$	$\frac{36}{90}$	$\frac{77}{90}$	$\frac{22}{25}$	$\frac{9}{10}$
$\frac{22}{35}$	$\frac{11}{20}$	$\frac{22}{35}$	$\frac{11}{16}$	$\frac{11}{15}$	$\frac{77}{100}$	$\frac{4}{5}$	
$\frac{11}{21}$	$\frac{33}{70}$	$\frac{11}{20}$	$\frac{11}{18}$	$\frac{33}{50}$	$\frac{7}{10}$		
$\frac{22}{29}$	$\frac{33}{80}$	$\frac{22}{45}$	$\frac{11}{20}$	$\frac{3}{5}$			
$\frac{11}{28}$	$\frac{11}{30}$	$\frac{11}{25}$	$\frac{1}{2}$				
$\frac{22}{63}$	$\frac{33}{100}$	$\frac{2}{5}$					
$\frac{11}{35}$	$\frac{3}{10}$						
$\frac{2}{5}$							

COMBINATION WITH ASCENDING RATIOS.

Drawing Table.

Editor:

When enlarging shops, the drawing room should also be enlarged, thus we are frequently obliged to fit up a special room which shall be used temporarily for drawing. An expensive equipment

would hardly be warranted in such a case, we are therefore obliged to cut down the expense of our equipment as much as possible.

Fig. 1 shows a group of three tables. These are plain flat top drawing tables about 36 ins. by 60 ins. Instead of tacking drawings on these tables and then pushing off by mistake all the reference sheets and drawings, etc., with the tee square, a wing *W*

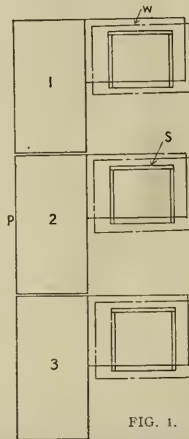

FIG. 1.

is added to each table as shown and the drawing board is mounted on to a saddle *S* and the drawing is made on these boards. We thus have our table clear for reference drawings, at the same time one is able to lay out a piece of work and then one can turn over the drawing board to a tracer.

The addition of this wing does not take away any of the space in the drawing room, as we simply close up the passage on one side of the table, we are thus using a lot of idle space to advantage. We still have our passage way around the tables as shown at *P*. These extensions *W* are made of white pine and have no extra work on them whatever.

Fig. 2 shows a detail of the saddle.

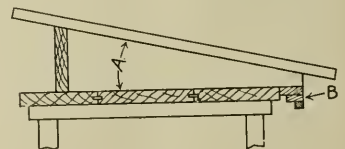

FIG. 2.

It is made of white pine and is nailed together. The angle *A*, at which the drawing board is operated, can be changed by using the different steps shown at *B*. This saddle is very cheap and can be applied to any table or removed entirely if so desired.

There is scarcely a drawing room which has not seen the day when a bottle of ink was upset over a tracing.



Fig. 3, shows an arrangement for holding the ink bottles. This is fastened underneath the table and of course it will be impossible to upset the ink on a tracing. As there are many drawing rooms in which both red

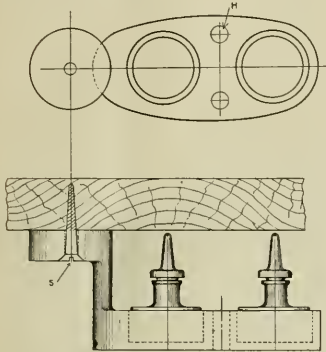

FIG. 3.

and black ink is used, this bracket is arranged so as to receive two bottles. Two holes, *H*, are cored in the cast iron bracket and into them the cork can be dropped. The screw *S* is placed in the table near the edge so that when the bracket is swung out, one can readily reach the bottles. When not in use the bracket is turned round and goes in under the table. A pattern for this casting can be made at very little expense, there is no machine work on it, except drilling the hole *S*.

Fig. 4 illustrates a foot stool, which is so convenient in connection with the drawing table that no draftsman should be without one. The figure

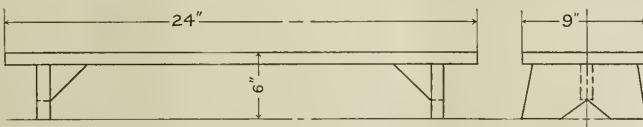

FIG. 4. FOOT STOOL.

represents a convenient size. The stools are made out of pine and are nailed together.

FRANK B. KLEINHAUS.

Royersford, Pa.

**Swan Song of the Locomotive.**

Editor:

Music to the writer has always been an entrancing, captivating and enthralling science, hence the rapt attitude and close attention that has been paid to the sweet swan songs that have been sung at several of the meetings of the N. Y. Railroad Club during the past year. It is known that the swan sings its sweetest song just before it dies, and on looking about at each meeting and observing the numbers of men in

the audience whose sole business in life for nearly two decades has been the killing of the steam locomotive, some of them engaged in this killing business in a wholesale manner, rapid fire guns, continuous warfare, others in what might be termed a retail trade, firing at infrequent intervals a thirteen in., and then listening to the sweet swan song of the steam locomotive, plans, suggestions, etc., for the next 100 years, the proper thing in Mallets and other types of greatness, would seem to portend that the swan is onto its job and that it has been realized that the time is at hand when from Miss Liberty to the Golden Gate and from the Great Lakes to the Gulf the cry will be high tension transmission for transportation of the sheep and the goats that ride in the varnished cars, also for those that ride in the freight cars, and that soon the time will arrive when the only steam toot-wagon left will be the great Mallet, and she will be found in a glass case in the Smithsonian institute, or some like institution, and all others will be relegated to the scrap pile, and about her will be grouped the only round-house foreman and the old fashioned locomotive engineer of whom in some circles we lately hear so often and see so never.

S. D. SMITH.

New York.

**Air Operated Vise.**

Editor:

Enclosed you will find a pencil sketch of my air device for operating a vise. You will notice that the screw is wrapped round the piston rod to act as a guide.

make it double on its tracks several times before it got down to business, and then only the dry and dusty steam could pass out of the separator. What the consular report says of the performance of the Schmidt superheater is as follows:

"Consul U. J. Ledoux, of Prague, writes that the question of increased speed has been closely studied of late by the Bohemian railways, and the Aussig-Teplitz Railway Company has been making most interesting experiments with the overheated steam locomotive system invented by Engineer Schmidt.

"By Engineer Schmidt's contrivance the steam coming out of the boiler, previous to doing its work in the cylinder, must pass through a system of pipes which are exposed directly to the combustion gases. By this process the particles of water still contained in the steam are also transformed into steam, adding considerably to the force of the loco-

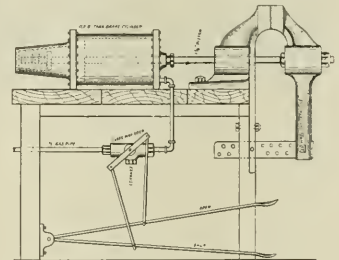

AIR OPERATED BENCH VISE.

motive. It is reported that locomotives with this system of overheated steam show a considerable reduction in the consumption of both fuel and water, enabling them to travel much longer distances without stoppage for feeding purposes. According to the opinion of local experts, great improvements in the service can certainly be accomplished. At a recent week's trial on the Aussig-Teplitz Railway, a speed of 110 kilometers (68.35 miles) an hour has been attained."

**Facts About Canada.**

Canada is larger than the United States by 250,000 square miles. Canada contains one-third of the area of the British Empire. Canada extends over 20 degrees of latitude—from Rome to North Pole. Canada is as large as thirty United Kingdoms, eighteen Germanys, thirty-three Italys. Canada is larger than Australasia and twice the size of British India. Canada has a boundary line of 3,000 miles between it and the United States. Canada's seacoast equals half the earth's circumference. Canada is 3,500 miles wide and 1,400 from north to south. The population is about 6,000,000, or about twice that of New York.—Montreal Herald.

The vise can be used where any ordinary vise is used, it is quick and reliable, and holds the work very firmly. Our blacksmith uses it as his helper, making pipe clamps and often for quite heavy work.

C. F. PERRY,

Assistant Foreman,

Copper Shop, T. & N. O. Rd.

Houston, Tex.

**Overheated Steam.**

One of the consular reports which recently came to our office bore the unintentionally humorous heading "Experiments with Overheated Steam." This reminds us of the description of a steam separator which we once read. The object of the separator, the critic said, was to fool the wet steam and

### Rapid Car Building in India.

BY A. R. BELL.

The value of good organization in any manufacturing operation is undeniable, and as a proof of what such organization can produce in India, a country proverbially considered as

pared was put under the body. During the time that the 88 coach builders had been busy with the actual framing up of the vehicle 3 maistries and 66 carpenters had made the doors, windows, blinds, seats, etc., and 9 trimmers had prepared the upholstery and

with their chargemen and foremen, who were engaged on this very creditable piece of work grouped in front of the result of their labors at 8.30 A. M. on Saturday, while No. 4 represents the inspection of the completed vehicle by the agent, Mr. H. Wenden, and deputy agent, Mr. F. T. Rickards, together with some of their friends.

The car has a body 62 ft. long and 9 ft. 6 ins. over the moldings, built on a steel underframe 60 ft. long, resting on four wheeled bogies spaced at 40 ft. centers. At one end there is a guard's compartment, next a small first-class saloon, to seat 6, then a large third-class room for 48 passengers and a smaller private one for 12 females; a luggage compartment finishes the vehicle. The car is arranged so that it can be run in either direction under similar conditions; it has all the usual appointments of a carriage intended for local service, with seats of the "turn over" type. There are no sunshades, but the roof, sides, and ends are protected by non-conducting material.

Bombay City is justly proud of its industries and this latest example of what Bombay men can do in a Bombay workshop, when their labor is accurately directed and their efforts "timed" in unison, is remarkable evidence of their ability to turn out work second to none in the British Empire.

When it is recorded that over 600 cubic feet of timber (in this case nearly all Australian) had to be ac-

slow, the feat recently accomplished at the Great Indian Peninsula Railway Company's workshops at Parel is an interesting illustration. Locomotives have been erected in England and America in incredibly short periods, but it has remained for India to produce a complete railway passenger carriage, painted and finished, ready for service, in 40 hours.

To compete with a new steam motor coach, the management required a composite "trailer" car for haulage by a small converted tank locomotive, and on March 1 of this year an order was given for the construction of such a vehicle. Drawings were made, the material prepared, and on Monday morning, March 26, the timber and details required, and the men to be employed in the work, were assembled. Our illustration, No. 1, was taken at 8.20 A. M.; and at 8.30 A. M. the men commenced operations. There were 88 men under 4 chargemen employed, and the time worked was the ordinary 8 hour day, without overtime. While a number of these men laid down the framing and formed the floor, others put together the side pillars and rails of the sides and ends in sections, and by "knocking off" time in the afternoon considerable progress had been made.

On Tuesday morning the various parts were "assembled" and during the day the whole of the body was framed together, and the "roof-sticks" secured in position. The second picture shows the state of affairs on Wednesday morning, when the steel underframe which had meantime been pre-

decorations. The carriage received its first or "primary" coat of paint on Wednesday afternoon. On Thursday a chargeman and 20 painters got to work, and the painting inside and outside was proceeded with and the outer roof and cover was put on, the doors were hung, windows were put into place, and the internal arrangements



No. 2—TAKEN AT 8.20 A. M. WEDNESDAY—WORK IN PROGRESS.

generally, completed. On Friday the new carriage received its final coats of paint and varnish and was lettered and numbered. The electric light fittings were put in, automatic vacuum brake adjusted, door handles, handrails, etc., were installed and the vehicle completed ready for the rails.

Picture No. 3 shows all the men

curately machined and of this, 4,000 sq. ft. planed and carefully prepared, some hundred of parts "assembled" in their proper order, with over 150,000 screws to hold them together, some idea can be formed of the magnitude of the work in hand and the complete organization prevailing at Parel where "every man to his particular work, at

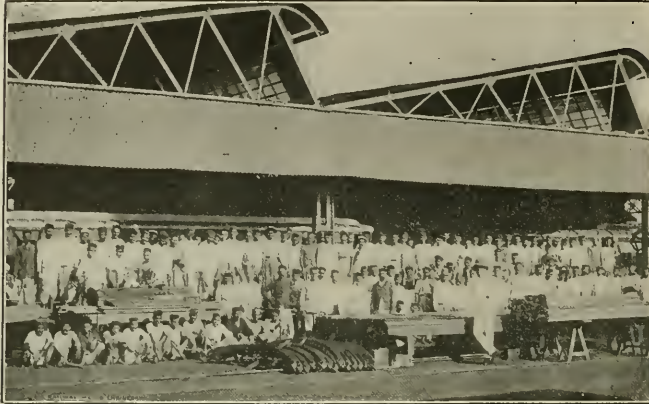

No. 1 TAKEN AT 8.20 A. M. MONDAY EVERYTHING READY.

the exact time and place," is the guiding rule of the establishment.

### Unloading.

BY A. O. BROOKSIDE.

Once upon a time there was a superintendent of motive power of a large and powerful railroad and he was great

with "line clear" orders toward the editor's sanctum.

One day, a gentleman appeared before the editor, box in hand; he had the password correct, which was that he came from the S. M. P. of the large and powerful railroad aforesaid. In his anxiety to quickly arrive, he had not taken time to remove sundry wisps of barley

usually went with a free-for-all coupler of tender years, but he failed to see anything of the kind while the "agricultural element" worked away and jointed up an awesome contraption. "Look here, my man," broke in the editor "that is the strangest coupler I ever saw; did the S. M. P. send you to me?"

The inventor paused while a look of pity and sorrow overspread his features. "This ain't a couple," he said. "it's single, and a darned good single potato digger it is, too." "Ah," responded the editor, "I see; and have you a sample of the work it can turn out?" The man rose slowly to his feet, and, looking calmly at the editor as one who doubted much without reason, he said: "Yes, I have; I've a sack of the best potatoes in all Sawback county in a bag I left at your door. They are samples of the work it turns out and you can take them home and try 'em. I intended to give them to you, anyhow, but I thought you wanted to put the digger in your paper—that railroad fellow said you did." "Ah, yes," replied the man of the pen, as light dawned on him. "I'm afraid the digger can't go in, but I believe an appreciation of the digger and some of its work can be got into the editor's head. I will take some home and try." And behold the inventor was of good cheer, for although he had given away something and got nothing in return, he had been listened to, which was a great reward.

Moral: Never swiftly turn away from your door an inventor who has the



No. 3—CAR FINISHED 5.30 P. M. FRIDAY.

friends with the editor of a railroad mechanical paper. The S. M. P. showed his friendship for the editor by putting him onto a lot of good things, and in the story we are telling the editor was put next to something which would otherwise have escaped him in his eager hunt for news.

These were the days long ago, which you can find in the pages of history indexed as the Coupler Era. It was subsequent to the Christian era and did not endure quite as long, but it was fierce and strenuous while it lasted. During the coupler era the people from Androscoggin to Ubadam invented railroad couplers and the "agricultural element," as farmers are called in the daily press, contributed their quota to the "won't work" shelves in the patent office.

The S. M. P., with a view of putting the editor onto the very "latest," received all the inventors (in his outer office and by proxy), and the second in command was trained to say to each: "You ought to give that epoch-marking invention of yours the widest publicity. Go at once, without a moment's delay, and see the editor; his office is round the corner in the next street. Yes, it's a splendid coupler. Good-bye." Thus it came to pass that the S. M. P., who dearly loved mechanical science and had even thought of becoming an inventor himself, did not take up a moment more than he could help of even the humblest inventor's time, but got him headed on a high speed route

from his whiskers and the S. M. P. and his second in command had not detained him long enough even to suggest anything but the necessity of a rush for publicity. The editor, desiring the agony to be as short as possible, requested that the box of tricks be opened forthwith. The man sat down on



No. 4.—8.30 A. M. SATURDAY—INSPECTION BY THE AGENT AND FRIENDS.

the floor and spread out his wares while the editor looked on and wondered. As the thing took shape the editor tried to perceive anything remotely resembling the grasping knuckles or clutches, or holders or lobster claw grabbers or snatch pins or arrow heads and sockets which then

fruit of the earth to give away, and do not advise an unknown man to seek, in hot haste, for publicity, for the wisps of barley in his whiskers are no indication of the contents of his bag and it may be that he has but concealed a generous heart under a poor and unpretentious garb of a humble inventor.

# Railway and Locomotive Engineering

A Practical Journal of Railway Motive Power and Rolling Stock.

Published Monthly by

**ANGUS SINCLAIR CO.,**

136 Liberty Street, New York.

Telephone, 984 Cortlandt.

Cable address, "Loceng," N. Y.  
"Glasgow," "Locanto."

**Business Department:**

**ANGUS SINCLAIR, President.**  
**FRED M. NELLIS, Vice-President.**  
**JAMES R. PATERSON, Sec'y and Treas.**

**Editorial Department:**

**ANGUS SINCLAIR, Editor.**  
**GEO. S. HODGINS,**  
**JAMES KENNEDY,** Associate Editors.  
**J. P. KELLY,**

**Advertising Department:**

**Eastern Representative, S. I. CARPENTER,** 170 Summer St., Boston, Mass.

**British Representative:**

**THE LOCOMOTIVE PUBLISHING CO., Ltd.,** Amen Corner, Paternoster Row, London, E. C.

**Glasgow Representative:**

**A. F. SINCLAIR,** 15 Manor Road, Bellahouston, Glasgow.

**SUBSCRIPTION PRICE.**

\$2.00 per year, \$1.00 for six months, postage paid in the United States, Canada and Mexico. For other parts of the world, \$2.50 or ten shillings. Single copies, 20 cents. Remit by Express Money Order, Draft, Post Office Order or Registered Letter. Mailing address can be changed as often as necessary—always give old and new address, and if you subscribe in a city, state who got it up. Please give prompt notice when your paper fails to reach you properly.

Entered at Post Office, New York, as Second-class mail matter.  
Copyright by Angus Sinclair Co., 1906.

For Sale by Newsdealers Everywhere.

**All Steel Passenger Cars.**

Quite recently a steel mail car on one of our eastern trunk lines was derailed and rolled down a twelve-foot embankment, and after turning over three times reached the bottom not much the worse for the accident. The occupants of the car were severely shaken up and bruised, but not seriously hurt. The two cars following the steel mail car were made of wood, and they were considerably damaged in rolling down the embankment.

This is undoubtedly an involuntary demonstration on the part of the railway company as to the ability of the all steel coach to stand hard knocks, and it is safe to assume that cars of this type will grow in popularity on American roads. The law of evolution holds goods in steel car construction as it does in other things, and with the more extended use of such cars and the wider experience which designers and builders will gain, it is safe to say that even better steel cars will make their appearance as time goes on.

The recent accident at Salisbury, in England, and the almost complete demolition of the cars which were in the ill fated train, has again forced this

question of car construction to the front. There is no doubt that the primary object of the car builder was not to construct accident proof vehicles, because railroads are supposed to be operated with a very large margin of safety, but the fact that serious accidents do happen, even on exceedingly well managed roads, is not to be denied.

In Great Britain and on the continent, where, by reason of the density of population, paying traffic was a certainty from the first, the roadbed, the bridges, the signal systems, and the discipline maintained, have probably received a larger share of attention than has been bestowed on the rolling stock, while in this country the building of long lines of railways through sparsely settled districts has tended to the production, at least in the pioneer days, of a less substantial roadbed and heavier cars than those of older lands. The standard of American railway roadbed construction has undoubtedly advanced, and the all steel car is now in a fair way to become a prominent feature on many of our important lines. The steel car, with its ability to undergo severe treatment, cannot, however, be relied on as the cure-all for railway accidents.

Our increasing use of the block system, the general spirit of improvement which is evidenced by the unification of train rules and operating practice, and the selection of the best forms of equipment as sought by our railway mechanical associations, are all part of the endeavor to make railroad operation not only economical but safe, and the steel car adds its quota to the safeguarding of life. If it assists in doing this one thing satisfactorily, its advent will be welcome indeed.

**Block Signal Legislation.**

During the last session of Congress instructions were issued by that body to the Interstate Commerce Commission to investigate the use of the block signal system, for the purpose of presenting data upon which a suitable law on the subject could be framed. Congress has acted wisely in so doing, and it is probable that the efforts of all concerned will be directed to that end. Hasty legislation on this important matter will thus be avoided. The action of Congress contemplates National rather than State regulation, and a desirable degree of uniformity all over the country will probably be the result.

The experience of other countries whose railroads are operated under some form of the block system, has been highly satisfactory, and it remains for those in authority to so deal with the matter that they shall secure for us that which will be most suitable to our own system of railroad operation, and

to our conditions, without imposing undue hardship on any railroad.

The block system is the best thing so far devised for preventing rear collisions on double track roads, and when applied to single track lines it protects the rear of each train, and pre-empt the road for a certain distance ahead. It obviates misunderstandings, and eliminates a great deal of danger by substituting the space interval between trains for that which is measured by time.

The method of train control by telegraph orders issued from the train dispatcher's office, though a perfectly workable system and theoretically safe enough, nevertheless involves the element of human memory and human faithfulness in the discharge of duty, and this inherent weakness in the system can never be entirely removed.

Many of our leading railways have voluntarily adopted the block system, and the fact that such roads have weighed it in the balance and have not found it wanting is certainly a strong argument in favor of its universal adoption. The automatic car coupler, the air brake, and other safety appliances, have been made the subject of National legislation with good results. The merit of the block system is now in a fair way to be impartially investigated and intelligently reported on, as a basis for embodiment in the law of the land.

**The General Foreman.**

The locomotive repair shop of to-day, in spite of its many improvements in mechanical contrivances, is no place for idlers. Strength, mental and physical, are in a marked degree required to meet the constantly arising difficulties that inevitably accompany railroad shop activity. All that human intellect can foresee and ingenuity accomplish cannot prevent breakages in the moving parts of machinery. Structural work must be taken apart quickly and reconstructed often with much haste, and with a degree of exactness that leaves nothing to be guessed at. Every piece of work on the locomotive has its story, and he who can read the aggregation of stories correctly and quickly is the man of the hour in the railroad shop. To know exactly what is wrong and what is best to do in the emergency are the qualities required. These attributes are not given to everyone. They do not come to anyone over night. They are the result of long and varied experiences clarified by study and observation and crystallized into instinct.

The general foreman of the railway repair shop should possess these qualities in an eminent degree. That he does not always do so, any more than generals of armies are not always fit

to command men in battle, goes without saying. Abraham Lincoln mourned when he heard that the Confederates had captured a general and four mules. He looked upon the seizure of the mules as a real loss. As for the captured general, Lincoln said that he could make another in five minutes.

Real generals, however, dominant spirits who can meet and master difficulties, are not made so readily. Neither are general foremen of machine shops to be made at a moment's notice. Favoritism, relationship with appointing power, and, indeed, many other causes will advance the incompetent, while modest merit must stand in the background, but the fictitious value of such advancement seldom lasts long. The weakling finds his level and goes to the wall, while the man of real merit generally comes to his own.

Young mechanics there are who dream dreams. Such a one thinks in his unsophisticated imaginings that if he were only a foreman all he would have to do would be to walk around with a gold watch in his pocket, an ivory rule in his hands, and a white collar around his neck, and that in an atmosphere of almost luxurious idleness he would pass his days. This delusion is dispelled before he comes to the longed for eminence. He finds his work doubled or trebled and his responsibilities magnified a hundredfold. He sadly finds his superiors jumping upon him morning, noon and night. He also finds mechanics whose delight it is to hoodwink and fool the bewildered foreman, with an ingenuity worthy of a better and kinder cause. He will find rivals watching him with the fierce hunger of a hyena watching a jackal. And for what recompense? The wages of a general foreman seldom amount to that of an ordinary engineer. Of all men employed on railways they are the poorest paid in comparison with the duties expected of them.

The general foreman must write as cleverly as a yard clerk. He must not only know how to do everything himself, but he must be able to give demonstrations to others. To everyone he must have a gentle word and a courtly smile. He must have the eye of a hawk and the skin of a rhinoceros. He must know the maximum speed limit of every tool in the shop and see that each is kept up to it. Disasters that fall upon his unoffending head must not only be met manfully but swiftly. He soon learns that the men at the other end of the shop are idle when his back is turned, and he turns fiercely upon them but struggles to conceal his indignation. He dreads that there are loose nuts on the bolts that hold the braces under the engine truck, and if he would see for himself he must crawl like a quadruped into the pit and perhaps finds that his

fears are well founded. Apprentices chase him for a change of work. Journeymen haunt his footsteps for more money, when there is none to give. In a few years the wear and tear begins to show.

There are better days, we believe, in store for the general foreman. There is a growing tendency on the part of the powers that be in the railway world to give a greater substantial recognition to the merits of the general foreman. RAILWAY AND LOCOMOTIVE ENGINEERING will endeavor to sustain and encourage this generous spirit. The general foreman is the coming master mechanic. He is the brains of the machine shop. He is among the hardest working, poorest paid man in railway work. His past has been dreary, but his future is full of hope. All things come to him who waits.

#### Railroad Economy.

The present condition of railroad property and the prevailing low rates of transportation are a powerful stimulus to railroad economy. Managers, superintendents, and the heads of mechanical departments are bent upon ferreting out every leak in the way of unnecessary expenditure, in order to increase the earnings, or perhaps create a margin for still lower rates for classes of freight that can not be otherwise obtained. This necessity for economy, it is safe to say, will never cease to exist, and if anybody expects that the time is near at hand when railroad managers will be able to work their lines at an absolute maximum of efficiency and minimum of expenditure, the expectation will not be realized. Too many things have got to be learned by investigation and experience, and they can only be learned little by little.

We would not underrate the importance of a saving economy in small things as being essential to the success of any business, and especially as it affects the prosperous working of the vast and complicated system of railroads in this country. But in looking at the subject from another point of view, it seems very much like saving at the spigot, to keep such a sharp watch upon the minor details of expenditure, and overlook the errors and shortsightedness of the general management in respect to the traffic. What is the use, it may be asked, of keeping up an incessant microscopic scrutiny of the ten thousand mechanical sources of wear and waste, the excess of dead weight in castings, rods, bolts, sills, etc., the quantity of water evaporated per pound of coal, the excess of fuel consumed per mile by one locomotive more than another, with the view of ascertaining the precise line between economy and waste—what is the use, it may be said, of all

this, if the substantial benefits are to be thrown away, as they have been time and again, in waging a ruinous war of rates, by which millions of revenue that would otherwise have been earned have been sacrificed with a reckless prodigality as injurious to business interests generally as it is demoralizing to railroad management.

We hold that economy of the minute, hair-splitting kind is time and labor wasted, unless what is saved is made to help the business of the roads and advance their prosperity as money making enterprises. Rate wars are a mutual cutting of throats to see which jugular will be emptied the quickest. The public naturally enjoy these periodical combats on account of the cheap rates they bring, although it is obvious that the more business the roads do at such rates the poorer they are. The average shipper or traveler cares little for this unless he happens to be a holder of the securities affected thereby. When dividend day comes round he begins to suspect something is wrong, but has little idea of the multitude of small economies that have been practiced in the operating and mechanical departments to help diminish the losses incurred by rate cutting and war.

#### First Aid.

The National First Aid Association of America have just issued their first annual report. There are six divisions under which the work of the association is carried on, the first is the Y. M. C. A. division; the second is the railroad division; the third is the fire and police department division; the fourth is the Salvation Army division; the fifth is the boys' work department and the sixth is the independent division. In the first division there are 23 classes in which first aid instruction is given and these include a membership of 267. The railroad division has five classes in working order and a membership of 194. The fire and police departments of Massachusetts division has 4 classes and 62 members. The Salvation Army division has 5 classes and 248 members. The boys' work department 7 classes and 189 members. The independent departments 13 classes and 156 members. Classes were formed in co-operation with the People's University Extension Society of New York City, 8 classes and 236 members. The total number of classes is 65 and the total membership is 1,376.

In the railroad departments of this work the Boston & Maine and the Boston & Albany employees have been represented. The classes formed among these railroad men have demonstrated the practical ability and value of first aid instruction for railroad men. First aid work on railways in England is a

recognized institution, and annual competitions between picked teams from the various roads are held and prizes awarded. The winning road holding a trophy for one year. First aid to instruction does not aim to make men amateur surgeons or make-believe doctors. It teaches common sense rules of conduct whereby the suffering of injured people may be lessened and their comfort attended to until medical aid arrives. The first aid instruction is based on common sense and its practice tends to make men cool, careful and self-reliant in emergencies. Railroad men generally have these qualities and when directed along the lines of first aid to the injured may be of incalculable benefit when occasion arises. Those of our friends who desire information regarding the railroad department should write to the secretary of the Association whose address is 6 Beacon street, Boston, Mass.

#### Popular Making of Alcohol.

We see the statement frequently made that farmers will be permitted to make denaturated alcohol from the products of their farms and that distilling apparatus will be as common as churns now are. We have no information concerning what rules the Government will establish for the manufacture of denaturated alcohol, but it is certain that proper restrictions will be imposed to prevent the manufacture of an article that might be turned into a beverage.

The liquid produced by the fermentation and distillation of farm products is known as spirits of wine or ethyl alcohol. It results from the fermentation of any product containing sugar or starch. The mess of stuff prepared for fermentation is called a mash and generally consists of finely ground corn or potatoes, to which is added a small quantity of malt or other compound containing diastase. The mixture is then permitted to stand until a natural change takes place, which converts the starch into sugar from which the alcohol comes. The spirit of wine resulting from the distillation of this mash is weak alcohol, the strong liquid being produced by redistillation. As soon as the spirit drops from the worm of the still it is ready for use as a stimulant, and it will be so used unless careful supervision is exercised in putting in the compound that will ruin it for drinking purposes. The spirit of wine contains a great deal of semi-poisonous ingredients, such as fusel oil, but in spite of that, immense quantities of the spirits are used by rectifiers for conversion into whisky, brandy, gin and other intoxicants. For some palates

the presence of fusel oil is the reverse of objectionable. There is a certain kind of whisky sold in low drinking places in Scotland, that is known as "kill the carter," which is considered the most efficient drunk creating liquid within the reach of light purses.

The rules to be established by the United States Government for the denaturization of alcohol have not yet been published, but we presume the practice will not differ much from that followed in Germany, where two methods are practiced, called the "complete" and "incomplete" degrees.

Complete denaturization is accomplished in two ways; first, by the addition to every 100 litres (26½ gallons) of spirit of two and a half litres of a standard poison. This is made by mixing four parts of wood alcohol with one part of pyridine (a product of the distillation of bones and coal tar), and 150 grains of oil of lavender or rosemary.

Instead of these, benzol is sometimes used. Of this "complete" product there was used in the year 1903-04 a total of 26,080,505 gallons. The incomplete denaturings are as follows: They are sufficient to spoil the alcohol as a beverage, but allow it to be used in certain processes for which the complete process renders it unavailable. (1) To twenty-six and a half gallons of grain alcohol, five litres of wood alcohol, or one of pyridine, are added. (2) To the same amount of spirit twenty litres of a solution of shellac. (3) By the addition of two and two-tenths pounds of camphor, (4) or two litres of oil of turpentine, (5) or one-half litre of benzol.

Alcohol to be used in the manufacture of ether, aldehyde, agaricin, white lead, brom-silver gelatins, photographic papers and plates, electrode plates, collodion, salicylic acid and salts, aniline chemistry, and a great number of other purposes is denaturated by the addition of ten litres of sulphuric ether, or one litre of benzol, or one-half litre oil of turpentine, or 0.025 litre of animal oil.

For the manufacture of varnishes and inks alcohol is denaturated by the addition of oil of turpentine or animal oil, and for the production of soda soaps by the addition of one kilogram of castor oil. Alcohol for the production of lanolin is prepared by adding five litres of benzine to each hectolitre of spirits. The price of denaturated alcohol varies in the different States and provinces of the empire in accordance with the yield and consequent market price of potatoes, grain, and other materials. At the present time alcohol of 95 per cent. purity, which is the quality ordinarily used in Germany for burning, sells at wholesale

from 28 to 29 pfennigs (6.67 to 6.9 cents) per litre (1.06 quarts), and at retail for about 7.8 cents per litre.

#### Power Brakes on Cars.

The Interstate Commerce Commission have taken up the matter of compliance with the safety appliance law as far as the equipment of brakes is concerned. Railway companies were ordered to report by the first of this month on the number of freight cars owned by them which had been equipped by them with power brakes.

The Commission, acting on the authority conferred by the amended safety appliance law of March 2, 1905, issued an order last November which increased the minimum percentage of power brakes to be used on all trains which are subject to the provisions of the statute.

Last October the Commission were in possession of reports which showed that about 88 per cent. of all the freight cars in the United States had been equipped with power brakes and the object of the recent order was to ascertain the progress made up to date.

The trains which, according to the rule of the Commission, must at least be equipped with 75 per cent. of power brakes are those which are run in inter-State traffic and one of the Master Car Builders' Association rules governing the interchange of cars which will go into effect September 1, 1907, requires that all cars offered in interchange must be equipped with air brakes. The operation of this rule will probably do more than anything else to hasten the equipping of practically all freight cars in the United States and Canada, with power brakes.

#### B. R. T. Troubles.

We find it difficult to characterize the disgusting spectacle witnessed on the Brooklyn Rapid Transit roads last month as other than rowdyism run mad. The real question at issue as to whether the company have the legal right to charge more than five cents for single trips on their city roads between certain points is one which will be eventually settled one way or the other in the State courts. The opinion of a certain judge has had the effect of inflaming the minds of a class of people not usually recognized as the most law abiding kind. When the company has given due notice that they intend disregarding such opinions and purpose charging ten cent fares it is criminal folly to try to travel by the company's roads and refuse to pay. We confess that our sympathies are with the railway employees who have shown great courage in the face of overwhelming difficulties

**Book Notice.**

The American Steel Worker, by E. R. Markham. Published by the Derry-Collard Company, New York. Second Edition, 1906. Price, \$2.50.

The second edition of this valuable book contains in addition to the matter already published, a section on high speed steel. This section contains 22 new pages and gives the latest information on the subject. It takes up effects of carbon, chromium, tungsten, silicon, etc., in tool steel; tells how tools of this material should be made; how tempering is best accomplished in the heating and hardening of the steel, and takes up speeds and feeds. New and old matter make a total of 366 pages with 136 illustrations. The book is well printed and bound and the illustrations are clear. Mr. Markham has had twenty-five years experience in the selection, annealing, working, hardening, and tempering of various kinds and grades of steel and is a practical man and knows whereof he speaks.

**Carbon in Steel.**

Steel wheels and other articles for railroad use are often made from what is known as an open hearth, high carbon steel, containing, as it is sometimes called, "point six-five to point seven-five carbon." These expressions are usually written .65 and .75 but the meaning of the figures becomes clearer when their actual per cent. value is stated. Such a steel has in it .0065 to .0075 per cent. of carbon. Taking 1,000 parts as the total, the steel of which we speak has as one constituent, something between 65/1000 and 75/1000ths parts of carbon. This steel, though below tool steel in the amount of its carbon, is capable of being tempered, if such be required.

**Flat Car Without a Deck.**

We have lately illustrated several specially designed flat cars, two of which were built for the General Electric Company, of Schenectady, for the carriage of heavy electrical machinery. Our line engravings here represent a flat car, designed and used on the Pennsylvania Railroad for the transportation of special material.

The car has a capacity of from 150 to 200,000 lbs. and itself weighs 43,000 lbs. It is literally an open space with a car built round it, if one may be allowed to say so. There are, of course, no through center sills, but the side sills are heavy box girders made of 15 in. channels with a plate riveted on top and bottom and a double plate top and bottom for 16 ft. 3 ins. in the central portion of the car. These box girders terminate at the body bolsters and are securely attached to them. There are short diagonal braces made of 3½x3½ angle irons and a triangular plate at each corner where body bolster and side sills join.

The body bolsters are themselves box girders 12 ins. deep, the channel webs of which are 10 ins. apart. From the center of the body bolsters the draw sills are carried out 5 ft., and the draw sills are also of the box girder type. Each end sill is one 15 in. channel and this meets the 15 in. channel which is the

ends of the short center draw sills and the space inclosed between body bolster and sill is covered with a plate which ties all together and makes a sort of platform 5 ft. 5 ins. by 10 ft. wide.

The box girder construction of this car forms an open parallelogram with short draw sills in the center at each

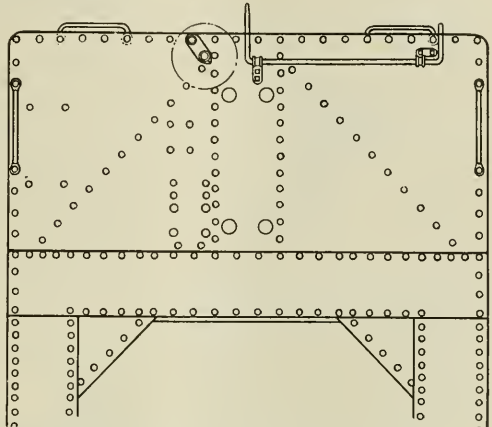

PLAN OF END OF PENNSYLVANIA FLAT CAR SHOWING ENDS OF BOX GIRDERS, DIAGONAL BRACES AND SHORT END PLATFORM.

end. In fact, this part of the car which is the essential feature, resembles the frame of a blue print apparatus with the glass and the wooden back out. The draw sills stand out from the bolsters like the trunnions of the blue print frame. The difference, however, is that while the blue print frame can turn over, the car does not.

The method of transporting material in this car is by supporting the piece to be carried on a bar or beam resting on the box girder side sills, and allowing the piece to hang down in the

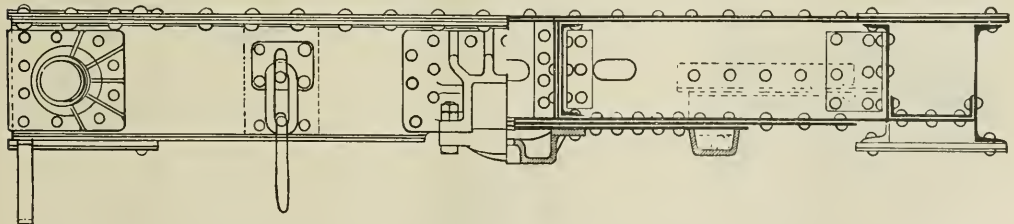

END VIEW AND SECTION OF PENNSYLVANIA RAILROAD SPECIAL FLAT CAR.

We may put the meaning of these expressions even more definitely by saying that the carbon has just the same proportion to the total mass of the steel as 65 cents has to \$10, or, taking the larger quantity of carbon mentioned, we might say as \$75 is to \$1,000. The carbon parts are so many to the thousand, and that is not per cent. in the strict meaning of the term.

outside member of the box girder, forming the side sill. The outer channel along the side is, therefore, about 38 ft. long, while the box girder side sill, existing as such, between the body bolsters is about 28 ft. 10 ins. long. The body bolster, therefore, lies between the box girder side sills, at right angles to them. Diagonal braces extend from the ends of the side sills to the front

center. The car is really a carrying frame with no more deck in the center than a flat mud ring for an engine. It is, however, strongly built and securely braced, and is admirably adapted to the special purpose for which it was designed.

Do not waste time, for that is the stuff life is made of.—Franklin.

Patent Office Department.

Brake shoes and truck box lids seem to be favorite objects with our inventors, and while at the first glance it might seem that we have seen something similar to these contrivances before, it will be found by careful inspection that there is nearly always

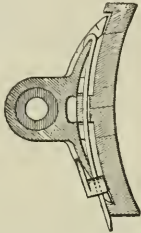

BRAKE SHOE FASTENING. I

some new feature that gives these devices a character distinctly their own and entitles them to the consideration of the mechanical world. We select a few of the most notable of the patents issued last month that ought to be of interest to railway men.

BRAKE SHOE FASTENING.

Mr. S. Webb, Glassport, Pa., has patented a simple and substantial brake shoe fastening, No. 295,453. The device embraces the combination of a brake head provided with notched upper and lower ends, a brake shoe provided with a central lug and a lower projection, a key passing through the lug and having an upper hooked terminal engaging the upper end of the brake shoe, and an adjustable clip upon the lower end of the key engaging the lower end of the brake head.

TUBE CLEANER.

A device for cleaning tubes has been patented by Mr. T. Andrews, Rockaway, N. J., No. 828,173. The mechanism

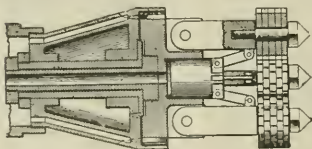

TUBE CLEANER.

ism comprises a head in the form of a truncated cone, and having an annular chamber for receiving motive agent, and also having a chamber at its inner end communicating through ports to a turbine mounted to rotate in the inner chamber. Blades are attached to the periphery of the turbine having a spiral trend, a collar engaging around the blades, tool carrying arms mounted on the turbine, and a pressure actuated disc connected with the arms.

TUBE CUTTER.

An improved tube cutter has been patented by Mr. L. T. Jones, Richville, N. Y., No. 828 120. The apparatus consists of a body provided with a central



TUBE CUTTER.

bore and having its walls incised longitudinally, forming a number of radially moved spring sections provided at their forward ends with divergently inclined inner faces and having adjacent recessed segmental enlargements, a number of rotary members journaled in the enlargements, with a conical shaped core fitted in the central bore and moving longitudinally and expanding the incised walls, and also means for moving the core back and forth.

JOURNAL BOX LID.

Mr. A. Lipschutz, Chicago, Ill., has patented a journal box lid, No. 813,504.

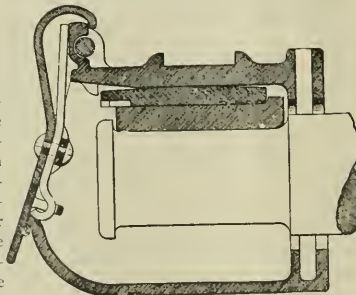

JOURNAL BOX LID.

The contrivance consists of a lid for the opening of the box, furnished with a spring, and bearing at one end against the upper portion of the box, the other end of the spring forming a lock which engages the lower portion of the box to hold said lid in position, and a stop for the spring near the lock.

AUTOMATIC SIGNAL.

Mr. Wm. A. True, Rule, Neb., has patented an automatic signal, No. 827-

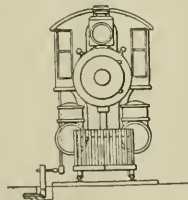

AUTOMATIC SIGNAL.

947, combining a railway motor and an alarm located in proximity to the driver of the motor and an extension project-

ing from the driving rod in such a manner as to actuate a latch held in position by spring action, and a series of posts set at points along the road bed where by the projecting arm will be moved against the action of its spring, thereby sounding an alarm.

JOURNAL BOX.

An improved railway journal box has been patented by Mr. C. L. Courson, Piteairn, Pa., No. 826,765. The box is

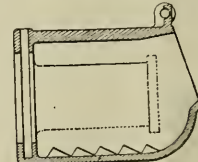

JOURNAL BOX.

of the usual form with the addition of a plurality of transverse ridges or flanges in the lower part of the box, the ridges having their sides of different degrees of inclination, the ridges inclining toward the inner end of the box and extending transversely of the axle.

The Westinghouse Machine Co., of East Pittsburgh, has recently sold to the United States Government for use in connection with the Panama Railroad two compound steam engines; one direct connected to a 325 K. W. 250 volt engine type generator, and the other to a 200 K. W. 60-cycle A. C. two-phase 220 volt generator. Both operate under a steam pressure of 150 pounds.

RAILWAY CAR TRUCK.

Mr. Spencer Otis, Chicago, Ill., has recently secured a number of patents on railway car trucks and we reproduce

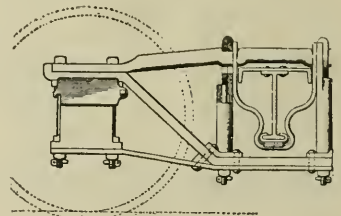

RAILWAY CAR TRUCK.

one of the number, No. 826,870. The combination embraces an upper arch bar circular in cross section and provided with recesses on each side of its middle point, a depending hanger formed of a strip of resilient metal having its upper ends resting in the recesses of the arched bar, and a bolster supported by the hanger.

So many men, so many minds, every man to his own way.—TERENCE.



# Our Correspondence School.

In this department we propose giving the information that will enable trainmen to pass the examinations they are subjected to before being promoted. If any of our students fail to understand any part of the instructions, we will gladly try to make them plainer if they write to us. All letters intended for Our Correspondence School ought to be addressed to Department E.

## Third Series—Questions and Answers.

52. For what is green and white combined used?

A.—It signifies a flag stop for passengers or freight train.

53. For what is blue used?

A.—That cars protected by a blue flag or blue light must not be moved.

54. In addition to red and green signals, what other signals are used to signify danger and caution?

A.—Any object waved violently by anyone near the track. The speed with which the signal is given usually indicates how it should be obeyed. If given rapidly it should be acted on rapidly; if given slowly, move cautiously.

55. What does the explosion of one torpedo signify?

A.—It signifies to stop.

56. Of two?

A.—Proceed with caution and look out for signal to stop.

57. How far must a train proceed with caution after running over two torpedoes?

A.—Until the stop signal is given or to the next station ahead.

58. How and when is a fusee to be used?

A.—Fusees are to be used when a train is in motion and desires to indicate its position to a train following without stopping. Fusees should not be dropped near wooden structures.

59. When burning on the track, how must it be respected?

A.—A fusee burning red must not be passed until it is burned out.

60. A flag or a lamp swung across the track, or any object waved violently on the track indicates what?

A.—It is a signal to stop.

61. What are markers?

A.—Markers are green flags by day, and at night lights showing red to the rear and green to the side and front, placed on the rear of a train.

62. What do they indicate?

A.—They indicate the end of a train.

63. If, while on a side track, a train meets or passes you without displaying markers how would you act?

A.—That would indicate that the passing train had parted. You should signal the train but remain clear until the rear portion had passed.

64. Are there any trains or engines that need not display markers? If so, what?

A.—When two or more engines are

coupled together, the second engine need not display markers. A train moved by a switching engine in a yard when drilling need not display markers. A switching engine does not display markers.

65. What signals must be carried on the front and rear of each train on the road after sunset or in fog?

A.—At night or in foggy weather the engine of a train must have its headlight, and classification signals; when lamps are carried, they must be lighted.

66. What signals are yard engines to display after sunset or in fog?

A.—A headlight in front and rear at night. When not provided with rear headlights, two white lights at the rear of the tender.

67. Should each car in a passenger train be in communication with the engine?

A.—Yes.

68. How is this done?

A.—By means of the air signal whistle, or by cord and gong.

69. What are classification signals?

A.—They are signals displayed to indicate that a train is running as an extra or that it is followed by another train. They are flags or lights displayed in the places provided for that purpose on the front of the engine.

70. What trains do not carry classification signals?

A.—Regular trains do not display classification signals.

71. What signals are used on a train to denote that it is followed by another on the same time and having the same rights?

A.—Two green flags by day and two green lights in addition by night displayed in the place provided for that purpose on the front of the engine.

72. What classification signals are carried by extra trains?

A.—Two white flags by day and two white lights in addition by night displayed in the place provided for that purpose on the front of the engine.

73. Are yard engines required to display these signals?

A.—No.

74. What does a blue flag by day and a blue light by night indicate, when placed on the end of a car?

A.—It indicates that workmen are under or about it and it must not be coupled to or moved or other cars placed in front of it so as to obscure the blue signal.

75. If necessary to remove cars so protected, what would be your first duty?

A.—To notify the workmen.

76. What is your duty when it becomes necessary to place cars on a siding in front of cars so protected by a blue signal?

A.—To notify the workmen.

77. What is the whistle signal for approaching stations, railroad crossings and junctions?

A.—One very long blast of the whistle.

78. What is the signal to apply brakes?

A.—One short blast of the whistle.

79. To release brakes?

A.—Two long blasts of the whistle.

80. What is the signal in answer to any signal except train parted?

A.—Two short blasts of the whistle.

81. What is the signal that train has parted?

A.—Three long blasts of the whistle.

82. Should this signal be repeated, and how often?

A.—This signal is to be repeated until answered by trainmen swinging hand vertically in a circle at arm's length across the track.

83. What do two long blasts of the whistle indicate?

A.—Release brakes.

84. What is the signal to call in the flagman from the west or south?

A.—Four long blasts of the whistle.

85. From the east or north?

A.—Five long blasts of the whistle.

86. How long should the fifth blast be?

A.—As long as the others, unless special rule on your road designates otherwise.

87. What are four short blasts of the whistle?

A.—The call for signals.

88. What are five blasts of the whistle?

A.—The signal to call in flagman from east or north.

89. What is one long, followed by two short, blasts of the whistle?

A.—A signal to call attention of yard engines, extra trains or trains of the same or inferior class or inferior right to signals displayed for a following section.

90. What is the signal for road crossings?

A.—Two long and two short blasts of the whistle.

91. What is a succession of short blasts of the whistle?

A.—A succession of short blasts of the whistle is an alarm for persons or cattle on the track.

92. What is the signal to be given

when carrying orders to a train at a non-telegraph station?

A.—This is according to the special rule of the railway company.

93. What is the signal to be given by enginemen on siding or double track to warn passing train that it is following another train too closely?

A.—This is according to the special rule of the railway company.

94. What is the signal to notify section men or other employees of fire along the track?

A.—This is according to the special rule of the railway company.

95. What is one tap of the signal bell when the train is standing?

A.—This is according to the special rule of the railway company.

96. What are two taps of the signal bell when the train is running?

A.—Stop at once.

97. When the train is standing?

A.—Start.

98. What are three taps of the signal bell when the train is running?

A.—Stop at the next station.

99. When the train is standing?

A.—Back the train.

100. What is the signal to reduce speed?

A.—Four taps of the signal bell.

### Calculations for Railway Men.

BY FRED H. COLVIN  
SCREW JACKS.

Next to the levers, perhaps the screw is the most important form of mechanism we have to deal with, but even this is useless unless we combine it with the lever in some form or other to give it motion and make it useful. Then, too, the screw is virtually an inclined plane, wrapped around a center or core.

But regardless of what it really is, or isn't, it is a very useful factor in our mechanical work and we find ourselves depending on it for a great many things, such as the jack screw for shop or road use. We know very well that it will lift great weights which we could not budge without it or with any ordinary lever. With a lever two feet long we can jack up quite a heavy load, but do we have any idea as to how much can be handled with any jack we happen to have?

Suppose we have a jack with a 3 ft. lever and the screw of  $\frac{1}{2}$  in. pitch or two threads to the inch. If we want to lift 5 tons, what power will we have to apply on the lever?

If we use both hands they will probably take up about 8 ins. on the lever, and as we want to find the central point at which we apply the power, we cut this in half and call it 4 ins. from the end of the lever, making the effective length of lever 36 minus 4, or 32 ins. long.

The lever is the radius or half diam-

eter of the circle we describe in making a turn of the screw, so we double this for the diameter of the circle and multiply by 3.1416 to find the distance through which the power is applied. Then 64 times 3.1416 equals 201 ins. Call this 200 ins. for easy reckoning in this case.

During this time the screw has raised (and forced the load up) one-half inch, we have moved the power 400 ins. for every inch the lever is raised. So we see that the lever idea comes into play again and that the screw simply gives us a lever which is 400 to 1. As 5 tons is 10,000 lbs., we divide this by 400 and get 25 as the force necessary to apply to the lever, 34 ins. from the center to raise 5 tons with this jack, just as though it were a lever of the proportions stated.

But there is this difference: There is a large amount of friction in the screw which is absent in the lever, but this very friction allows the screw to hold the load at any point without slipping, while the lever cannot do this. So that the friction is not an unmixed evil.

The friction of a screw in its nut will probably be about 50 per cent., or, in other words, half the force applied will be used to overcome the friction, so that it will be necessary to double the 25 lbs., or to apply 50 lbs. pressure to raise the load with this jack.

Suppose you have a jack with a screw 3 threads to the inch, a bar at which you can apply power 40 ins. from the center of screw, and that you can apply 100 lbs. pressure at this point. How much will it lift, allowing 50 per cent. for friction of screw and nut?

The power moves through a circle twice 40 or 80 ins. in diameter. Multiply this by 3.1416, giving 251.344 ins. As there are three threads to the inch, we must turn the screw three times to raise the load one inch, so we multiply 251.344 by 3 and get 754.032, which we call 754 as the decimal is so small. The lever (or its equivalent) is 754 to 1 and taking half of the 100 lbs. pressure as being effective, we multiply 754 by 50 and get 37,700 lbs. or nearly 19 tons as the load that can be raised.

Put in the form of a rule we can say: Multiply twice the effective length of the lever by 3.1416.

Multiply this by the number of threads per inch of screw.

Multiply this result by the pounds pressure applied to lever and subtract whatever allowance for friction you decide on. Or, it is easier to do this before multiplying by the power; in other words, to multiply by the effective power instead of the total power applied.

This gives load that can be lifted.

To find power required to lift a certain load we reverse part of this rule as follows:

Multiply twice the effective length of lever by 3.1416.

Multiply this by threads per inch.

Divide this into the load to be lifted and the result is the effective power required to lift the load.

Or, assuming the load you must lift and the power you can apply to find the length of lever necessary.

Multiply twice the effective length of lever by 3.1416.

Multiply this by the threads per inch.

Multiply this by the effective power you can apply.

Divide this into the load to be lifted and you have the length of lever required.

This seems to be a good place to show the use of formulas in all calculations.

There is nothing "scary" about them if you keep cool and collected, and the best way to do this is to understand just what they are and why they are used. The best way to do this is to see how they are made, as in this way you can easily understand their advantages and they have no further terrors.

Formulas are simply another way of expressing a rule in arithmetic and are used because they save time in calculating, save space in note books and other books, and can be remembered much more easily where it is necessary to do so. It is not a good plan, however, except for the more common formulas, to attempt to remember them. If you know where they can be found at short notice it is usually sufficient.

After once learning that multiplying the diameter by 3.1416 gives the circumference of a circle, you never forget it, and yet it is a formula, as follows:

$$D \times 3.1416 = C,$$

which simply means that diameter multiplied by 3.1416 equals circumference.

Or we can omit the multiplication sign entirely and write it

$$D \ 3.1416 = C, \text{ or } 3.1416 D = C,$$

where D = diameter.

$$C = \text{circumference.}$$

Taking our first rule for jacks we can make it into a formula by saying:

Let L = length of lever to point of application of power (effective length)

$$T = \text{number of threads per inch.}$$

P = pounds pressure that can be applied to lever.

W = load that can or must be raised.

Then we can write the rule as follows:

$$2L \times 3.1416 \times T \times P = W,$$

or we can omit the multiplication signs, as 2L means L multiplied by 2. We can also write it:

$$2(3.1416 L T P) = W.$$

which means that after multiplying all the figures inside the brackets together, the whole thing is multiplied by 2.

Inclosing part of a formula in brackets may look hard, but it simply means that the terms inclosed are to be worked out

first and the whole thing multiplied by the number outside.

Taking our first example and handling it by this formula, we put down:

$$2 \times 32 \times 3.1416 \times 2 \times 25 = W,$$

and multiplying them all together find that W equals 10,000 lbs.

The second rule shows another advantage of the formulas instead of rules — i. e., the ease with which they can be transposed for finding different factors of the problem.

The second rule, put down as a formula, will be:

$$\frac{W}{2L \times 3.1416 \times T} = P.$$

which reads:

Load divided by 2L times threads per inch times 3.1416 equals power required.

Taking the first problem again we simply put down the different values in place of the letters and we have:

$$\frac{10,000}{2 \times 32 \times 3.1416 \times 2} = 25 \text{ lbs.}$$

Transposing again to find the length of lever, we have:

$$\frac{W}{2 \times 3.1416 \times T \times P} = L.$$

This reads:

$$\frac{10,000}{2 \times 3.1416 \times 2 \times 25} = 32.$$

It is not difficult to see how valuable these formulas are and when it is all made clear, they cease to be puzzling and can be handled by anyone who will exercise a little care.

If at any time there is any difficulty in transposing them, just take a very simple example and work it all out by the first rule which is all multiplication.

Then transpose by using the figures instead of the letters so as to always keep the values both sides of the = sign, exactly alike.

A very simple case of this will be as follows:

Let A = \$20, your rent per month.

B = 12 months, the term of the lease.

C = the amount you pay owner per year.

Then  $A \times B = C$ , or  $\$20 \times 12 = \$240$ .

Now we can transpose as follows:

$$A \times B = C \text{ or } \frac{C}{A} = B, \text{ or } \frac{C}{B} = A.$$

as we can prove by the figures,  $\frac{\$20 \times \$240}{\$20} = 12$  months, or  $\frac{\$240}{12} = \$20$  per month.

In brief, that is the whole secret of formulas and they are such a help they should be mastered. There are some formulas which require a Philadelphia lawyer to unravel but these are not required by us ordinary mortals and need not trouble us at all. Those that we need we can handle without difficulty if we use a little care and common sense.

## Questions Answered

### TRACTIVE POWER FORMULA.

(79) A. D. P., Winnipeg, asks:

What is the formula for calculating the tractive effort of a Vauclain four cylinder compound when working as a simple engine? A.—The formula used in calculating the tractive of this engine working in single expansion is

$$T = .85 \left( \frac{C^2 \times S}{D} \right) + \left( \frac{c^2 \times s}{D} \right) \times \frac{P}{2}$$

where T is the tractive effort, C is the diameter in inches of the high-pressure cylinder; c is the diameter in inches of the low pressure cylinder; P is the boiler pressure, and D is the diameter in inches of the driving wheels. The formula, however, reduces to this simpler form:

$$T = \frac{(C^2 + c^2) \times .425 P \times S}{D}$$

The constant 0.425 is obtained in the process of cancellation, which eliminated the figure 2 from the denominator of the fraction. The constant 0.85 is the per centage of boiler pressure allowed by the Master Mechanics' rule for the mean effective pressure in the cylinders.

### APPLICATION WITH CONDUCTOR'S VALVE

(80) J. C. O., Scranton, Pa., writes:

Kindly settle a few points in connection with the operation of the E T engine and tender brake, about which there is some difference of opinion. The first one is this: Will the brakes apply on the engine and tender, if the train breaks in two, or the conductor opens his valve? A.—Yes, but the brake cylinder pressure on the engine and tender will gradually reduce, if the engineer allows the handle of the brake valve to remain in running position when such an application occurs.

2. In case a conductor opens the conductor's valve or the train breaks in two, where should the engineer place the brake valve handle (H<sub>2</sub> brake valve)? A.—In the emergency position, as this will not only prevent reduction in cylinder pressure but it will also add the equalizing reservoir volume to the application chamber of the distributing valve, and thus increase about 20 per cent. the engine braking force. The rule governing the action of the engineer in such cases as you cite is practically the same as that covering the older equipment. With the E T equipment the escape of air at the brake valve exhaust while train is in motion is a warning to the engineer that the brakes are applying from the rear from some cause, and he should quickly place the handle in emergency

position and leave it there until the train stops. However, whether he does or does not the train brakes will not be affected.

### POSSIBLE BREAK OF ECCENTRIC STRAP.

(81) R. J. McK., Calgary, Alb., writes:

Would you please say if it is or is not possible that the reverse lever going into the corner with a slam, running at high speed, might break an eccentric strap, 4 ft. 6 in. drivers, large consolidation engine, all bolts in eccentric tight, and eccentric tight on axle? A.—It is possible to break an eccentric strap that way, but it may not be as likely to happen as that something else will give out. When the reverse lever was dropped into the corner, the travel of the valve was suddenly lengthened and its speed was at once increased, and this throws a heavy strain on the valve motion. If there is any lost motion in any of the joints, a serious jar is likely to occur, and in any case, a breakage, if one took place, would probably be in some of the parts upon which the pushing or pulling strains come directly. The eccentrics in turning round in the strap have a gradual action, if one may say so, on the strap, which is going on all the time, and when the load is suddenly increased, for that is practically what happens, the parts receiving the more or less straight pull and push of the motion are likely to feel it first, and a weak spot gives out, but if the eccentric strap is the weakest it may break first.

### DOUBLE HEADING, N. Y. TRIPLES AHEAD.

(82) H. F. D., Toledo, O., writes:

We very often get several New York triple valves ahead in freight trains, and we occasionally have double headers on them, handling the brakes from the head engine. Sometime ago we made an emergency application from the head engine and was surprised to find the brakes all setting in service. To be sure about this we released and recharged and then tried it again, but could get only service. What was wrong with the triples and how could it be overcome? A.—It is well known that a train of 40 or more cars, double headed, with New York triples next to the engine, quick action cannot be obtained from either engine when an emergency application is made, and so far as practical results are concerned with this combination, the whole train might as well be equipped with plain triple valves. There is nothing wrong with the New York triples to make them produce the result you noticed; they simply do not as a rule go into quick action when emergency applications are made from either engine of a double header. This is because the fall in pressure at the first New York triple, next to the engine, is not sharp

enough to make the triple piston move with sufficient rapidity to cushion the air between it and the vent piston so that the latter will open the vent valve. Quick action failing on the first triple naturally it fails on the whole train. To prevent this failure of quick action when emergency is wanted, place Westinghouse triples ahead.

2. Suppose this train had been going about 18 or 20 miles an hour, and the engineer had made an emergency what would the effect be? A.—The effect would be largely dependent upon the number of cars in the train, their condition, and whether loaded or empty. But with the ordinary freight train of to-day, consisting of not less than 30 cars, and frequently of from 65 to 90, there can be little doubt but that the train would suffer tremendous shocks with the possibility of buckling and its consequences, and of injury to the crew in the caboose.

#### TRACTION POWER FORMULAS.

(83) J. L. C., Swampscott, Mass., asks:

Will you kindly tell me how to calculate the maximum tractive effort of a simple engine, a compound working simple, and running compound? A.—(1) The formula for the tractive power of a simple engine is

$$T = \frac{d^2 \times s \times .85 P}{D}$$

Where T is the tractive power in pounds, d is the diameter of the cylinders in inches, s is the stroke in inches, and D is the diameter of the driving wheels in inches. (2) The formula for a Vauclain compound working simple is given in answer to question No. 79, of this issue. (3) The tractive power formula for a two cylinder compound is

$$T = \frac{d^2 \times s \times \frac{3}{4} P}{D}$$

and the formula for a Vauclain compound, working compound is

$$T = \frac{d^2 \times s \times \frac{3}{4} P}{D} + \frac{l^2 \times s \times \frac{1}{4} P}{D}$$

where l is the diameter of the low pressure cylinder as d is the diameter of the high pressure cylinder.

#### TIME TO CHARGE 100 CARS.

(84) W. H. C., West Albany, N. Y., writes:

1. We have had a discussion here about the time it takes the Westinghouse cross compound pump to charge 100 cars. Some think the new pump can charge that number of cars in about half the time it takes an 11-inch pump to do it, and in a little less time than the N. Y. No. 5. Please decide.

A.—The time required by the 8½ in. cross compound pump to charge 100 cars depends somewhat on the boiler pressure, main reservoir capacity, length of brake pipe, size of equipments, whether 8 or 10-in., and to what pressure they are to charge. Assuming that the boiler pressure is 200 lbs., the main reservoir capacity 50,000 cu. ins., there is no leakage in the system, all equipments are 8-in., the cars an average length of 40 ft., and the pressure is to be 70 lbs., the cross compound will charge a train of 100 cars in about 5 minutes. The N. Y. No. 5 could perform the same feat in a little more than double this time, or say 12 minutes, while the 11-in. pump would require about 15 minutes, and the 9½-in. about 22 minutes. Leakage in the system, of which there is always some, will increase this time somewhat.

2. If a 100-car train breaks in two and is again coupled up, how long ought it take the cross compound to pump off the brakes? A.—When recoupled, after breaking in two, all conditions as cited above the time required by the cross compound to release the rear brakes will depend on the amount of excess pressure carried and the frictional resistance to flow of air on the brake pipe more than on the capacity of the pump. It would require probably about 20 seconds to release all brakes, and if the cars were equipped with K triples, less than this would suffice to get all brakes off.

#### SAFETY VALVE PROBLEM.

(85) O. D. E., Tracy, Minn., writes:

(1) The area of a safety valve is 12 sq. ins. The weight of the valve and stem is 10 lbs. The distance from the fulcrum to the center of the valve is 4 ins. The weight of the lever is 15 lbs., and the center of gravity is 20 ins. from the fulcrum. If the ball is 35 ins. from the fulcrum and weighs 75 lbs., at what pressure will the safety valve blow off? A.—61.77 lbs.

$$\text{Ex. } \frac{75 \times 35 + 15 \times 20 + 10 \times 4}{12 \times 4} = \frac{2965}{48} = 61.77 \text{ lbs.}$$

#### EQUALIZING CYLINDER CLEARANCE.

(86) A. J. D., Whiting, Ind., writes:

With one piston rod ⅞-in. shorter than the other, can the clearance be equalized in both cylinders by changing the liners in the main rod, so that both cylinders will have the same amount of clearance, everything else being equal? A.—Yes, the clearance can be equalized. When the piston is exactly in the center of its stroke, the distance from the center of the piston to the center of the driving axle is a fixed amount, made up we may say, for sake of example, of the length of the piston rod and the length of the connecting rod. The piston rod length is

fixed but the length of the connecting rod can be varied. If one piston rod is too short and the connecting rods on both sides of the engine are the same length, the piston on the side in question, that is the short side, will be nearer the back of the cylinder than the other. If you lengthen the connecting rod the required amount on the short side it will push the piston to the exact center of the cylinder and the clearance in both cylinders will be alike. In doing this you push the crosshead slightly forward, and it will thereafter run up nearer the cylinder head than it will to the yoke each double stroke. Care must be taken to see that it does not strike at the cylinder head end. If there is room enough, the piston clearance can be equalized, but the crosshead clearance will not be alike at both ends of the stroke, nor will it be the same as that of the other crosshead. The slight difference in the length of the two connecting rods will practically make no difference to the engine.

#### Electric Trucks.

A pamphlet describing electric motor and trailer trucks has just been issued by the American Locomotive Company, illustrating the types of this equipment, designed and built by them. The pamphlet begins with a description of the principles of the designs, of which fifteen are illustrated by full-page drawings. Each illustration is accompanied by a list of dimensions. The designs illustrated include motor trucks for the New York Central suburban service, for the Paris-Orleans, the Schenectady, the Delaware & Hudson, the Brooklyn Rapid Transit, the Buffalo & Lockport and other railways. The drawings show the construction in detail, rendering it an easy matter to study the designs. In addition to the drawings, nearly all of the trucks are illustrated by reproductions from photographs. Among the details illustrated are: Cast steel and wrought iron bolsters, truck hangers, spring planks, Binkerhoff-Doyle wheel hubs and journal boxes with collarless and collar axles. Copies of the pamphlet will be supplied to those who write direct to the American Locomotive Company.

#### Safe Traveling.

The Canadian division of the Michigan Central Railroad, formerly called the Canada Southern, has closed the thirty-first year of its existence without having had a single accident in which a passenger was killed. The mileage of the division is more than 500 and the record is such, that officials of the company think it would be difficult to duplicate.

# Air Brake Department.

CONDUCTED BY J. P. KELLY.

## Diagrams of K Triples.

Mechanical drawings are not sufficiently clear to everybody so that they are always clearly understood. Because of this fact and of the increasing

reservoir or cylinder, is the symbol K 1 or K 2, as the case may be, cast on the side of the body, and the projection cast on the top.

The K 1 triple goes on where the H 1 (F 36) triple is used, and the K 2 where the H 2 (H 49) is required.

The K triple valve has two positions for release of the brakes; one, the full release, shown in Fig. 2, and the other retarded or we might term it, slow release, as shown in Fig. 5.

In diagram Fig. 2 the brake pipe is represented as connecting to the triple at the point *B P*, so that brake pipe air can flow into passage and chamber *a*, past the check valve into chamber *Y*, thence upward through passage *y*, in the slide valve seat, through port *j*, in the slide valve, to chamber *R* and the auxiliary reservoir.

It can also, at the same time, flow through passages *e*, *f* and *g* into chamber *h*, thence through feed groove *i* into chamber *R* and the

In Fig. 2 all parts are represented as being in their normal positions, that is, with the triple valve, the emergency, and the check valves in position to charge the auxiliary, and to release the brake. Port *j* is incorporated in the K 2 triple, used on 10-in. equipments, but not in the K 1. The K 1 triple is used on the smaller equipments, hence does not need this additional feed port.

A gradual reduction in brake pipe pressure, such as is required for a service application, causes the parts to assume the position shown in Fig. 3, service position. Here it will be seen that ports *i* and *j* are closed, preventing back flow of auxiliary air into the brake pipe; that the exhaust port *p* is closed so as to prevent escape of cylinder air; and that ports *Z*, in the slide valve, and *r* in the seat, are in register so that air from the auxiliary may flow direct to the brake cylinder at *C*. At the same time port *y* in the seat, leading from chamber *Y* and the brake pipe, and port *o* in the slide valve, are in register, and cavity *v* in the graduating valve spans ports *o* and *g* so that brake pipe air can flow down through port *t*, past the emergency piston, into chamber *X*, and to the brake cylinder at *C*. The emergency piston is fitted loosely so that this can be easily done, without undue tendency to move it.

This figure very clearly shows the manner in which brake pipe air is ad-

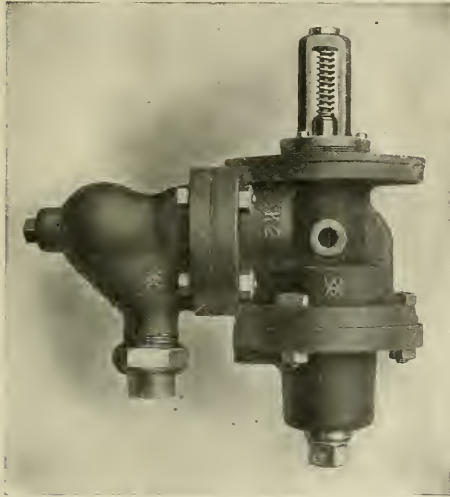

FIG. 1. WESTINGHOUSE "K" TRIPLE VALVE.

interest taken in the K triple valve, we publish in this number five diagrammatic drawings which illustrate it in all of its operative positions, and we also publish a drawing, Fig. 7, showing the arrangement of ports and cavities in the slide valves, and in the seat as actually constructed.

A diagrammatic drawing is one in which all parts of the mechanism represented are shown on one plane without regard for their relative positions as they really are in the mechanism itself, and these drawings shown herewith in Figs. 2, 3, 4, 5, 6, enable the reader to trace easily the course of the air through the various ports and passages.

As stated in the June number the general exterior appearance of the K triple is the same as that of all other Westinghouse quick action triples, and although the K triple is perfectly interchangeable with the older type, without alteration in the piping, it is illustrated here in the half tone Fig. 1, so that it will be all the more readily recognized. About the only difference between this and the older type that can be noted when it is bolted to its

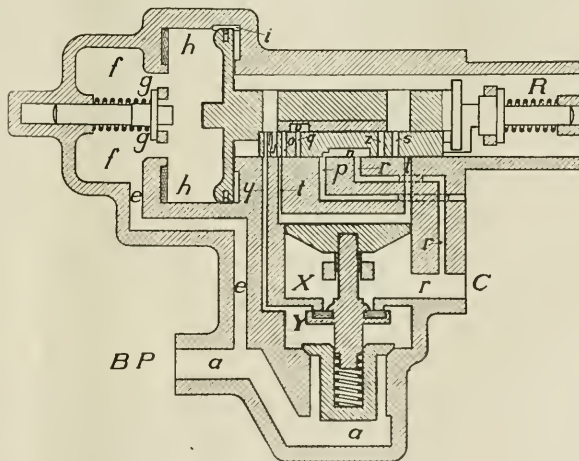

FIG. 2. FULL RELEASE AND CHARGING POSITION.

auxiliary reservoir, charging up the latter to the same pressure contained in the brake pipe.

mitted to the brake cylinder in service applications, and hence why it is that the service reduction is transmitted so

quickly to the rear of a long train, applying all brakes evenly and with a uniform pressure.

The service lap position is shown in Fig. 4. The valves assume this position when the auxiliary pressure re-

forward brakes is what prevents the slack of long trains from running out, and the consequent breaking in two of the train. Closing the feed port *i* brings about a more uniform recharging of the auxiliaries throughout the train.

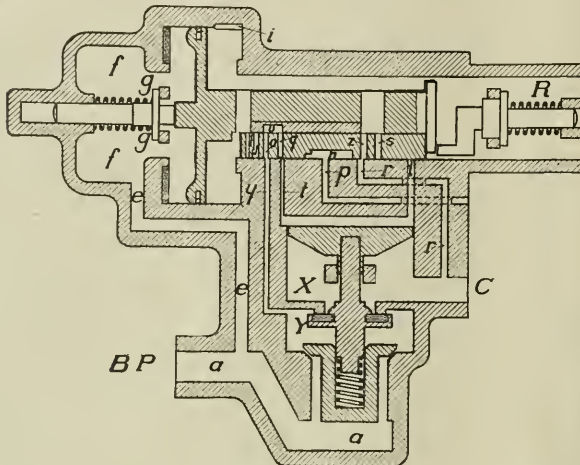

FIG. 3. SERVICE POSITION.

duces to the same amount as that in the brake pipe, or equalize with it, the same as with the ordinary triple.

In Fig. 5 the parts are shown in what is known as the retarded release position. The triple piston moves to the right far enough, when the main reservoir air flows rapidly into the brake pipe, to close feed groove *i*, leaving feed port *y* open to the auxiliary, and thus checks the recharging of the auxiliary reservoir; and the exhaust cavity *n* in the slide valve is also moved to the right far enough to reduce its opening considerably, and cause a slow escape of air from the brake cylinder, thus retarding the release of the brake. The spring on the slide valve end of the triple is compressed whenever brake pipe pressure is considerably higher than auxiliary pressure, but as soon as the auxiliary is charged up nearly even with the brake pipe, this spring will return all parts to their normal position, where the exhaust port *m* and the feed groove *i* will be wide open, as in Fig. 2.

When brakes are released by moving the handle of the brake valve to release position, the main reservoir air flows rapidly into the brake pipe raising the pressure up much higher in the forward end than in the rear of the brake pipe. Hence, the forward brakes are held applied, the rate of recharging the auxiliary is reduced and brake pipe air can flow with greater force toward the rear, and materially hasten the release of those brakes.

This retarding of the release of the

Thus it will be seen that the K triples makes the release of all brakes on a long train much quicker and more certain and uniform than is the case with the present quick action triples on trains of fifty or more cars.

In emergency applications the K triple operates just the same as the

### Air Brake Piping.

At various times in the past this subject has been discussed in the columns of this paper; and by various individuals and by railway associations it has been given serious consideration. The result is that for a long time it has been known that the straighter the air brake piping is made the more satisfactory will be the action of the brakes in both service and emergency applications, especially in the latter.

Although this is a fact, a careful inspection of the cars that make up our trains, and of the locomotives that haul them, would lead one to believe that those who are both directly and indirectly responsible for the kinds and conditions of piping to be found on them, were entirely ignorant of the effects which crooked piping and numerous elbows produce on the operation of the air brake, so well have they succeeded in getting in the largest number of short bends and right angled elbows possible, and this, too, when better methods of arranging the piping, in nearly every case possible to be had, would eliminate the elbows and at the same time considerably reduce the length of pipe required, and the cost, for each car and locomotive. A careful inspection of the piping on the hopper bottom and gondola types of coal cars will convince anyone of the truth of this statement.

The matter of a few additional unnecessary elbows and of the unneces-

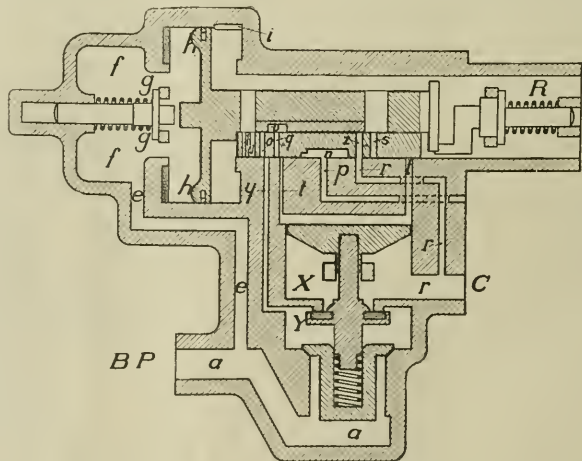

FIG. 4. SERVICE LAP POSITION.

present triple, except that a train fully equipped or partially equipped with them will get the rear brakes on considerably quicker than with the present triples and also with a little higher pressure. The relative positions of the parts and ports in emergency is shown in Fig. 6.

sary greater length of piping, is not in itself a very serious one, but when the effects they produce in these days of long trains, fast time and congested traffic are considered, it becomes one of grave importance, demanding prompt attention from those concerned with a view to an immediate betterment.

To make clear the reasonableness of our objections to the presence of ells and short bends in piping, let us consider a few points concerning them to show clearly how they interfere with the proper action of the brakes, and in

some extent injure them, if of modern construction, and if of the older and weaker type, crush and derail them.

But it is in emergency applications that the objectional influence of crooked piping is plainly seen, and at times

whether they are of the standard type or are not standard. With engines whose total length is 72 ft., double headed, making a total length of about 150 ft. of 1 in. brake pipe intervening between the brake valve on the leading engine and the first car, quick action is sure to be obtained when an emergency application of the brakes is made, provided standard quick action triples are next to the second engine, and the engine and tender brake pipe connections are put up free from right angled elbows and sharp bends. This means that all brakes apply throughout the train before there is any chance for the slack to run in hard, hence, that the train will come to a stop in the shortest possible distance without shock or derailment. But let the condition be such that the number of elbows between the leading break valve and the first car runs up to 19 or 20, as is the case nowadays on several roads, and quick action of the triple valves will be sure to fail when an emergency application of the brakes is made from the leading engine of a double header; and the consequences of the failure to get quick action when wanted is certain to produce bad results caused by brakes going on hard on front portion of train, rear end coming up hard against it, and in consequence train buckling and spreading over opposite track, collision of either passenger or freight train then due and approaching on that track, with possible loss of life and property.

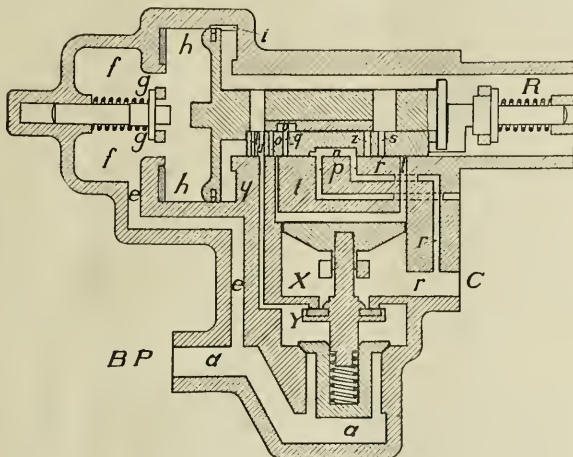

FIG. 5. RETARDED RELEASE POSITION.

consequence how they can produce disastrous results.

Every mechanic and engineer knows that any fluid, be it a gas or a liquid, will flow through a straight pipe of any given diameter with much less resistance than it will if the pipe contains short bends, and hence will flow more quickly. Bearing this in mind, it will be seen that a service application of the brakes, which requires a gradual reduction in brake pipe pressure, will be felt considerably quicker at the rear of a long train if the piping throughout is as straight as ordinary conditions will permit than it will be if the piping is excessively crooked. Hence with straight piping the application of the service brake will be smooth and the cars in the train will be free from the heavy strains which tend to rupture knuckles, to produce break-in-tuos, and also damage lading. If the piping is excessively crooked, shocks and stresses result; and from this cause, as well as from any other cause, the cars are damaged, trains break in two and lading is injured, thereby increasing the cost to railway companies of maintenance of rolling stock, and of claims for damage by shippers.

There are conditions of train make up conceivable, with regard to the location of loaded and of empty cars in the train, where the difference in time between the application of the service brake on the forward and on the rear end due to crooked piping may be so great as to cause enormous pressure, though gradually applied, to come on the cars toward the middle of the train, and to

is the most disastrous in its effects. Let us take for example, a fifty car freight train hauled by a double header. If an emergency arises the leading engineer will quickly put the handle of the brake valve in emergency position, with the expectation that the rear brake of that train will be on full inside of three

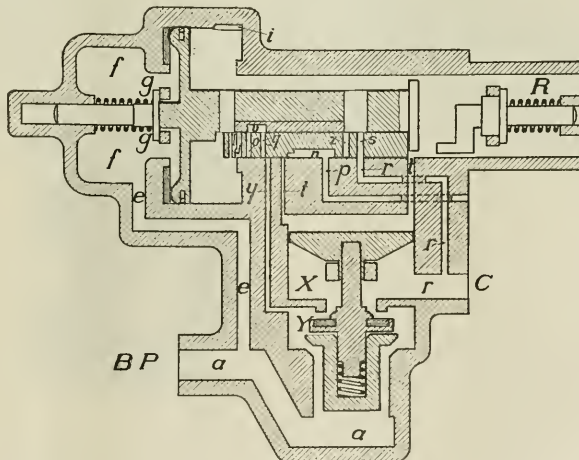

FIG. 6. EMERGENCY POSITION.

seconds after he does this. But whether his expectations are fulfilled or not will depend on the condition of piping on the engine and on the cars next to it, with respect to the number of elbows and short bends it contains; and it will also depend on the kind of triples that are placed next to the engine, that is,

This is the result to be expected from the crooked condition of the piping in air brake equipment that at present exists to a large degree, a condition entirely unnecessary and, therefore, one for which there is no excuse. In our opinion it is a condition which no railroad official should allow longer to

exist, since if a movement is put on foot to remove it, soon it will disappear and the wrecks caused by it diminish and soon cease altogether.

If one will only take an occasional trip through our large railroad yards to observe the condition of the air braking on many of the cars, especially with respect to loose clamps, and position of angle cock on the ends, he will wonder that accidents from closed angle cocks are not more numerous than they now are.

Loose clamps especially on the ends of brake pipes, allowing the ends to vibrate and the angle cock to strike against the endsills, thus causing it to work shut, are becoming too numerous, and prompt and effective measures should be taken to improve this condition.

#### Cabinet for Train Orders.

On many railroads there is a lack of any uniform system concerning the handling of train orders. One office may have a good method of dealing with this important matter and others may be very deficient in doing the same kind of work. With a view of introducing not only a good method but of reducing it to a uniform and easy system, the B. M. McClesky Train Order Cabinet Company, of Louisville, Ky., have devised a neat looking cabinet which can be placed on a telegraph operator's table, and while within arm's length is yet sufficiently out of the way to leave the table or desk free for writing or telegraphing, etc.

The cabinet is an ingenious invention which is used to file train orders before delivery, and is equipped with levers to operate the train order signals.

It is strongly made out of seasoned oak, the levers are of wrought iron, and the clips are made out of metal. There are little bars attached to the walls of the cabinet and these work on pivots which the operator must lower in order to place his first order. This act puts an obstruction in the way of the lever so that he cannot set the signal from force of habit.

This arrangement is intended to make it more convenient for the operator to do things correctly and to prevent him from acting in a blind way from force of habit. The train order signals are arranged so that they stand in the normal stop position with the levers vertical in the cabinet and out of the way. The clips for holding the orders are on the hinged doors of the cabinet. When the first order is received it is placed in the clip on the north or south bound side as the case may be, and the clip is hung up on the little horizontal bar which locks the vertical lever and the signal in the stop position. The operator, therefore, does not pull the lever

and so lower the signal, from force of habit. Instead of that, the lever remains locked with the order calling for its release hanging on the locking bar waiting for the arrival of the train which the order is intended. The signal being at "danger" halts the train, and in order to lower the signal to the proceed position, it is necessary to take down the

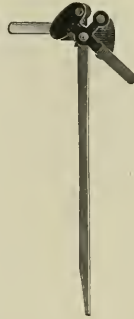

order clip, remove the locking bar and pull down the signal by bringing the lever down on the table.

There can be no cause for mistake here, because the arrival and the stopping of the train, and the appearance of the conductor will take place even if the operator had forgotten all about the train after he had received the order and hung it on the locking bar. When the signal is in the proceed position the lever, which is twenty-four inches long, is lying across the table and is consequently more or less in the way when he is working at his instrument, so that

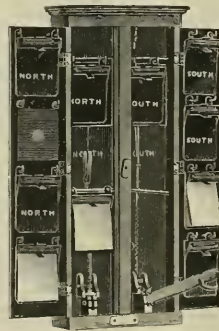

TRAIN ORDER CABINET.

as soon as the train has received its orders and departed the operator is practically compelled to return the lever to the vertical position, lock it with the little horizontal bar and hang up the clip where it belongs. There is a difference in the clips which prevents any of them being put in a wrong place.

The inventor of this device is a locomotive engineer who has been in active service on one railroad division for

twelve years and is still on the foot-plate. He has observed the habits of telegraph operators, and believes that his system will prevent an operator from performing his duties in obedience to force of habit or blind routine. This device does not conflict with the block signal system but has been devised as a substantial aid to the telegraph operator in the performance of his duties.

The inventor himself has been daily faced by the hard railroad fact that the life of a conscientious, able and thoroughly reliable man and those on his train, may be sacrificed by the carelessness or even by the momentary forgetfulness of a fellow employee whom he may not know and cannot warn. The seriousness of this fact is beyond dispute. Every effort to introduce the supremely important element of safety into railway operation is a move in the right direction, and while the train order system remains, it is the bounden duty of every responsible railroad officer to throw around it every safeguard that the intelligence of man can devise. We, therefore, commend the idea contained in this invention, and the principle involved, to the consideration of all classes of railroad men.

#### Steam and Electric Locomotives

A pamphlet just issued by the American Locomotive Company presents a paper read before the New York Railroad Club by Mr. J. E. Muhlfeld, general superintendent of motive power of the Baltimore & Ohio Railroad, and the pamphlet contains extracts from the discussion inserted by permission of the Club. The frontispiece are the Mallet Articulated Compound, built for the B. & O., and the electric locomotive used on that road. The paper opens with a description of the electric locomotive, giving details of design, record of its performance since going into service in 1903 and statistics of the average cost of operation and maintenance per hundred miles run. The next seven or eight pages are taken up with a description of the Mallet Articulated Compound, shown in the frontispiece, giving special features of design, and comparing it as to total weight, tractive power and hauling capacity with two consolidation locomotives which together were formerly required to do the work now done by the Mallet. Then follows a record of the performance of this locomotive. Mr. Muhlfeld then goes on to mention some of the results obtained from this type of steam locomotive which cannot be duplicated by other single units of steam, electric or internal combustion locomotives in use on American railroads to-day, and to give a short resume of the requirements modern railroad motive power must



fulfil. Following this is a statement of equipment necessitated by the use of electricity for motive power and that required where the steam locomotive is used, and a summary of the general features for a modern locomotive. Mr. Muhlfeld compares the electric and steam locomotive from the standpoints of efficient and economical operation and maintenance, pointing out the necessity of reducing the initial cost of electrification by increasing the efficiency and economy of present types of stationary boiler and by improvements in the means of generating, distributing, converting and transmitting electrical current. The rest of the pamphlet is taken up with discussions of the paper by Mr. F. J. Cole, Mr. H. B. Vaughan of the C. P. R., Mr. W. E. Potter of the General Electric Company, Mr. Angus Sinclair, and Mr. W. M. Smith, closing with a summing up by

with the first driver, and the first driver is equalized with the main and rear, so that all the wheels under the engine itself are equalized and the 6-wheel truck under the tender is arranged with center plate and side bearings in the usual way. The tender truck springs are arranged like those of a passenger coach 6-wheel truck, so that each pair of wheels bears an equal weight. The spring buckles shown in our illustration are arranged not in the center of each spring, but toward the outside in each case. The reason for this was explained in our Correspondence School columns in the August issue, Fig. 4, page 374. The valve gear is indirect and piston valves are used, having a travel of  $5\frac{1}{2}$  ins., and they are set line and line in full forward gear, and with  $\frac{1}{4}$  in. lead at a cut-off of 6 ins.

The boiler is straight top, wide fire box radial stayed,  $70\frac{1}{2}$  ins. in diameter

water and coal is considerably increased, the weight is also greater. These locomotives are provided with grates 92 ins. long by 85 ins. wide. These are intended for burning anthracite coal of pea size, because the locomotives are to be used in service where smoke would be objectionable. While not intended for long runs, the coal capacity of 4 tons and water capacity of 3,850 gallons would permit these locomotives to be used in runs which are long enough for any ordinary suburban district. These are believed to be the heaviest and most powerful locomotives specially designed for regular suburban service.

Some of the principal dimensions are as follows:

Wheel Base—Driving, 15 ft.; rigid, 15 ft.; total, 35 ft. 10 ins.

Weight—In working order, 225,000 lbs.; on drivers, 136,000 lbs.

Ax'es—Driving journals, main, 9x12 ins.; others, 9x12 ins.; engine truck journals, diameter,

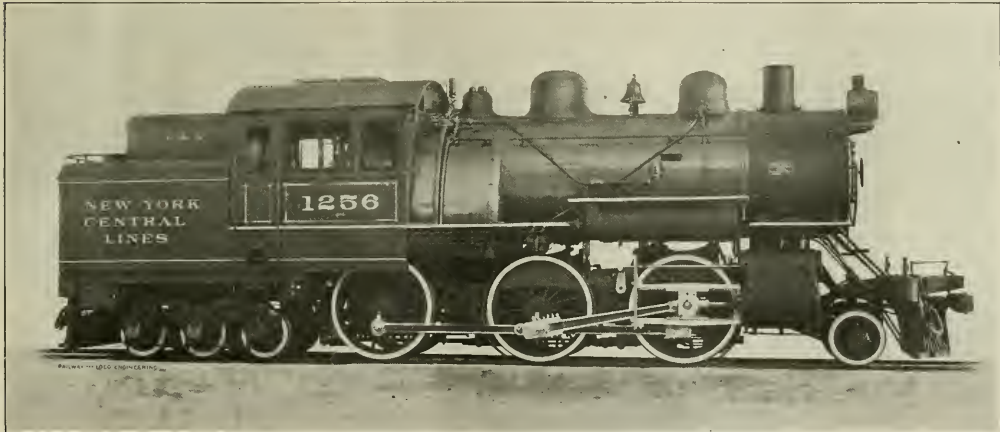

HEAVY SUBURBAN PASSENGER 2-6-6 FOR THE BOSTON AND ALBANY.

John Howard, Superintendent of Motive Power.

American Locomotive Company, Builders.

Mr. Muhlfeld. A copy of this pamphlet may be obtained by applying direct to the American Locomotive Company.

#### Boston & Albany Suburban.

The Boston & Albany division of the New York Central & Hudson River Railroad has put into service ten simple suburban locomotives of the 2-6-6 type, having a weight of 136,000 lbs. on drivers. These locomotives have 20 by 24 in. cylinders and 63 in. driving wheels. The boiler pressure is 200 lbs. per square inch and the tractive effort 25,900 lbs. This is unusual power for a locomotive designed for suburban service. The driving spring arrangement of this engine is such that the main and leading drivers have overhung springs, and the pony truck in front, which is of radial swing center bearing type, is equalized

at the smoke box end. The crown and roof sheets, each made of one sheet, are arched, beginning at a point 21 ins. from the mud ring. The crown sheet is laid out on a radius of 72 ins., and there is a maximum steam and water space of about 22 ins. above the highest point of the crown sheet. The heating surface is 2,423.4 sq. ft., and the grate area 55 sq. ft., giving 44 times as much heating surface as grate area. The fire box contributes 148 sq. ft. of heating surface, and the rest is made up in the tubes, of which there are 365, each 12 ft. long and 2 ins. outside diameter.

The basis of the whole design is an earlier suburban locomotive built for the New York Central & Hudson River Railroad, at the Schenectady Works, early in 1902. For the Boston & Albany locomotives the tank capacity for

$6\frac{1}{4}$  ins.; length, 10 ins.; trailing truck journals, diameter, 5 ins.; length, 9 ins.

Boiler—Working pressure, 200 lbs.; fuel, pea coal.

Fire Box—Type, wide; length, 92 $\frac{1}{2}$  ins.; width, 85 $\frac{1}{4}$  ins.; thickness of crown,  $\frac{3}{8}$  in.; tube,  $\frac{1}{2}$  in.; sides,  $\frac{3}{8}$  in.; back,  $\frac{3}{8}$  in.; water space, front, 5 ins.; sides, 4 ins.; back, 4 and 5 ins.

Brake—Pump, 9 $\frac{1}{2}$  in. L.; two reservoirs, 18 $\frac{1}{2}$ x8 $\frac{1}{2}$  ins.

Engine Truck—Two wheel radial swing, center bearing; trailing, six wheel swing, center bearing.

Tank—Style, U shape; capacity, 3,850 U. S. gallons; fuel, 4 tons.

Wheels—Engine truck, diameter, 30 ins.; trailing truck, diameter, 30 ins.

Coolie women act as railway porters at Mandalay, and carry heavy trunks on their heads from the train to the river steamer, a distance of about 200 yards, for a fee of one half-penny per package. —N. Y. Globe.

### Automobile and Horse Car.

A new combination car for the transportation of automobiles, horses, and carriages has lately been brought out by the Boston & Maine Railroad, and is for express service. The car itself is 61 ft. 1½ ins. long over sheeting

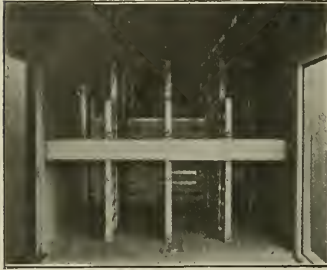

STALL ARRANGEMENT FOR HORSES.

and 10 ft. 0¼ in. wide, measured from outside to outside. It is mounted on two six-wheel trucks, and is of the baggage car type, with blind or stub ends without vestibules.

The weight of the car including the trucks is 96,000 lbs. and it will comfortably accommodate sixteen horses, or the entire floor space may be utilized for automobiles or carriages. There are two doors in each side, one 4 ft. wide by 6 ft. 3 ins., and the other 8 ft. wide by 6 ft. 3 ins. high. The wide doors are opposite each other, and so are the narrow ones. There are also two end doors or rather there are two doorways in each end. One is the B. & M. standard 25¼ ins. wide by 6 ft.

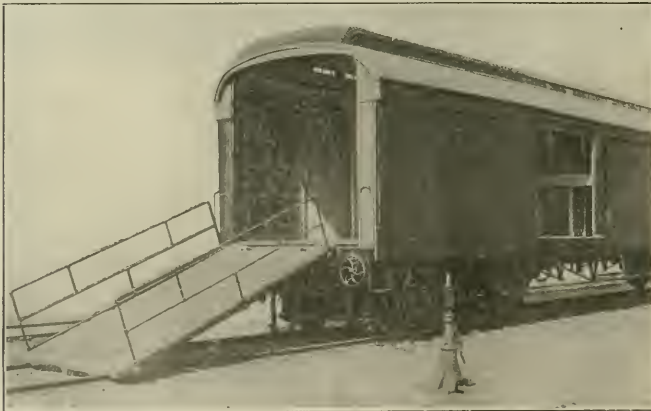

VIEW SHOWING CAR READY FOR AUTOMOBILES.

6¾ ins. high and the other is practically the full available width of the car, 7 ft. 6 ins. wide by 8 ft. 0¾ ins. high. This latter is closed by two doors which are

hung on door posts on side of the cars and close together in the middle, like the doors of a public building. It is through the open end of the car that vehicles are usually loaded, though the wide side doors may be used for this purpose as occasion demands.

The interior of car is equipped with 12 sliding stall partitions divided as follows: At each end of car there are three sliding stall partitions, which when placed in position ready for use make four equal sized sections, and will contain four horses. Between the side door openings, there are two sets of sliding stall partitions; having three partitions similar to those in the ends of car, separating these two sets is a gate in two sections each of which swings against opposite walls of car when they are not in use. These two center sets accommodate four horses each, thus making a total capacity of sixteen horses when the entire 12 stall partitions have been placed in position ready for the loading of horses. The construction and arrangement of the sliding stall partitions is such that one or more stall partitions can be set up to accommodate one, two or more horses. All stall partitions not in use to be placed against side walls of car and fastened there, leaving the remainder of the space throughout the car for the loading of automobiles or carriages.

When vehicles are to be loaded, all the stall partitions are removed, and placed against side walls of the car and fastened to brackets attached to side walls. The stall breast bars which are fitted into sockets on side walls when in use, can be taken down and placed in brackets which are fastened to the

car and the chains also keep them where they belong in the car.

Extending across the width of car, and resting in brackets attached to the side plates, are the stall partition supports on which the stall partitions slide. When not in use, these supports are taken down and placed on brackets fastened to the side plates. These supports are also fastened to the car with chains to prevent their being removed and to prevent them being shifted from their right positions. When these changes have been made, it gives a clear

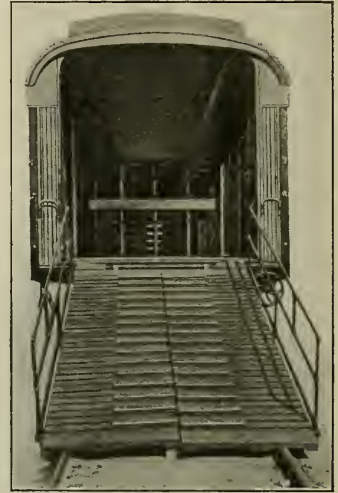

FRONT VIEW—READY FOR HORSES.

space throughout the entire length and breadth of car for either the loading of automobiles, carriages, baggage or general merchandise.

When it is desired to load or unload through the end doorway, two skids and three skid bars, with two guard rails made of iron pipes and fittings, are removed from their place under the car. The skids are attached to eye bolts in the face of the buffer beam. The two skids are further held and supported by the three wrought iron skid bars which are to be placed through clips on the underside of each skid. The guard rails are then fitted into the sockets on the side of the skids, and an inclined gangway is thus quickly made ready for use.

The car looks well and conforms in general appearance with the B. & M. style of passenger equipment. It is lighted with Pintsch gas, having three lamps placed along the clearstory roof. The gas is carried in two tanks, underneath the car, having a combined capacity of 301.4 cu. ft. The Consolidated Heating Company's system is used with by-pass valves inside the car. The Westinghouse quick action, high speed

underside of lower part of the roof. The stall breast bars are fastened to the side wall of the car by chains, which prevent them from being taken from

brake is used with 14-in. brake cylinder. The car is also equipped with the air signal. There are hand brakes at one end of the car, beside the narrow door. The wheels are 33 ins. in diameter with steel tires and the axles have journals  $4\frac{1}{4} \times 8$  ins.

The body bolsters are made of cast steel made in I-section, and in plan something like the letter H, the two uprights of the letter being separated from each other by about 4 ft. 4 ins. centers and each reaching from side sill to side sill. The crossbar of the letter is thus placed longitudinally under the center of the car and carries the center casting. The resemblance to the letter H, however, is not exactly accurate, because the cross car members are not only joined by the piece carrying the center casting but they are joined at

monitor roof boards, 14 ft.  $1\frac{1}{4}$  ins.; height from rail to top of eaves, 11 ft. 4 ins.; height from rail to top of buffer beams, 4 ft. 2 ins.; height from rail to center of couplers, 2 ft.  $10\frac{1}{2}$  ins.; length inside of end sheathing, 60 ft. 0 ins.; width inside of side sheathing, 9 ft.  $1\frac{1}{8}$  ins.

#### Steel vs Iron.

Iron worked up by smiths in medieval times was produced by a process akin to the puddled steel process and was almost identical with the material used at the present time under the names of ingot metal or soft steel. Many of these forgings are in existence at the present time, but to duplicate these forgings by the use of puddled bar would be impossible even with the help of Tubal Cain.

This tribute to the smiths of old was

indicated that there was a larger proportion of carbon in steel than in wrought iron, but this does not hold good at the present time as some of the mild steels made now-a-days contain no more carbon than some kinds of wrought iron.

Sir William Armstrong, the great English steel maker, believes that steel is iron produced by fusion instead of by a process of adhesion, and in that case it is entirely independent of any particular amount of carbonization. Steel, therefore, has an advantage over iron in being free from defects of welding and it generally contains more carbon than wrought iron does. This makes steel stronger and it is tougher under certain tests but more liable to fracture under others.

The manufacture of steel is continually improving while that of iron is practically stationary, and will eventu-



AUTOMOBILE AND HORSE CAR—BOSTON AND MAINE RAILROAD.

H. Bartlett, Superintendent of Motive Power

J. T. Chamberlain, M. C. B. J. W. Marden, Asst. M. C. B.

their ends by pieces passing under the side sills. The bolster is cast all in one piece and thus supports the side and the center sills as well as reaching from one side of the car to the other. The bolsters are thus able to provide a large area of support at each end of the car. The side bearings are bolted to the bolster and slope up to the center so as to bring the truck back to its normal position when the car is running on straight track.

The cars have standard monitor roofs and are ventilated by swing sashes, eighteen on each side. The cars can be used for horses, automobiles, carriages, baggage or general merchandise, and are altogether very useful units of passenger train equipment. A few of the principal dimensions are as follows: Length over couplers, 64 ft.  $\frac{1}{2}$ -in.; distance from center to center of trucks, 42 ft. 7 ins.; width over eaves, 10 ft.  $2\frac{3}{4}$  ins.; height from rail to top of

given by Mr. Thomas Lace in a paper read before the Railway Club of Pittsburgh not long ago. Mr. Lace is foreman blacksmith for the Pittsburgh Coal Company. Speaking of the uses of steel vs. wrought iron, among other things he said, cast iron is not malleable but crumbles to pieces after being heated and struck by the hammer, and wrought iron is produced, though malleable as a pasty mass, the temperature of an ordinary furnace being insufficient to melt it. Wrought iron is more fibrous than mild steel, and it contains from the method of its manufacture, an average of 3 to 7 per cent. by volume, of slag. The slag is distributed through the mass and detracts from the strength of the iron.

The process of fusion used in the manufacture of mild steel, eliminates the slag. This is a great advantage as regards homogeneity and strength. Former definitions of the word steel in-

ally merge into that of steel as produced by the process of fusion. The decadence of the iron industry as such may be back to A. D. 1784 when Cort introduced the puddling furnace and the rolling mill into England. Quantity began to take the place of quality, as a more impure iron was made by this process than by the old fashioned open forge process. The use of charcoal in blast furnaces probably helped in some degree to keep the quality of the iron made. The hot blast introduced by Neilson in 1828, and the use of coke instead of charcoal in the process of smelting and refining assisted to keep up the quality in the manufacture of iron. From this time on iron began to take on its modern characteristic, which is lack of homogeneity. Charcoal iron, however, held its place in America long after its manufacture in England had been virtually abandoned for general purposes.

At the present time the quality of the scrap used in the manufacture of wrought iron has deteriorated. For instance, we may have a pile of red short, cold short, and double refined iron, also mild steel of differing qualities with their various oxides, the whole making a conglomerate cemented together or not cemented in places by the presence of dirt. Iron as made by the puddling process served its purpose in the early days of railroads and steam navigation, but what would be thought of constructing locomotive boilers, rails, bridges, wire rope, steel cars, and a whole host of articles now made of steel, if we had to go back to iron.

One railroad entering Pittsburgh adopted steel in place of iron about 1895. The steel they then got was as a whole unfit for railroad work. At the same time Lowmoor iron axles were imported from England and about the same time they got some 8 in. round Lowmoor iron for crank pins. The axles did not give as good service as steel, and several of the crank pins flawed in the process of case-hardening. All had to be ground to shape, as owing

to finish formerly demanded when ordinary carbon steel tools were used. The advent of high speed steel has rung the death knell of all close forging, and

side bearings, and truss irons can be advantageously made of steel. In freight car work with a few exceptions the work in steel can be bent cold by



NEW ELECTRIC LOCOMOTIVES READY FOR THE ROAD WITH OVERHEAD CONNECTION FOR ROAD CROSSINGS.

what with milling machines, heavy lathes and planers, saws, twist drills, etc., steel is now cut as readily, if not as rapidly, as wood.

Steel as regards its application to locomotives is making rapid strides as ap-

proachable, and in relation to lasting or wearing qualities, steel brake hangers, bolts, truss rods, fulcrums, brake levers and bolts from  $\frac{3}{8}$ -in. up to 1 $\frac{3}{4}$  ins. give better service than their equivalents in puddled bar iron.



TEST TRACK FOR N. Y. C. ELECTRIC LOCOMOTIVES SHOWING THIRD RAIL ALONG THE LINE AND OVERHEAD CONTACT FOR HIGHWAY CROSSINGS

plied to castings, but the limit has not been reached in forgings. All the spring rigging can be made from steel, and give better service than iron. The same may be said of driver brake and engine truck work. For passenger cars, swing hangers, equalizers, truss rods, bolsters,

to the slab welding process of manufacture, they took an oval shape in cooling. This instance is given to show that a superior grade of iron is not equal to the average mild steel.

Steel forgings, which are to be machined, do not require the close margin

#### Service in the Electric Zone.

Last October, the first half of the specified 50,000 mile endurance test of the first high speed electric locomotive built jointly by the General Electric Company and the American Locomotive Company, was completed on the test tracks of the New York Central Lines at Schenectady. On June 12 of this year, the locomotive completed the second half of this service test. The maintenance expense per mile amounted to \$0.0126. This figure includes maintenance of motors, brake shoes, tires, inspection, and other miscellaneous items. The operating conditions in this test were more severe than those to which the other thirty-five electric locomotives will be subjected. The test locomotive hauled a train averaging from 200 to 400 tons over a six mile track and high speed running under these conditions involved higher braking and accelerating duty than in regular operating service.

Our illustration shows eight of the thirty-five electric locomotives, each of which weighs 100 tons and can develop 2,200 h.p. These have been built for terminal service on the New York Central for New York City and vicinity. There are now fourteen machines complete. Of the eight locomotives shown, two have already gone to New York. Those yet to be built are well under way at the shops of the General Electric Company and the American Locomotive Works and it is expected that all will be ready for service in early October.

# Of Personal Interest.

Mr. W. C. Hope has been appointed general passenger agent of the Central Railroad of New Jersey, vice Mr. C. M. Burt, resigned. Mr. Hope has been associated with this road for many years. He was born in Somerville, N. J., educated in the Wyckoff School, Elizabeth, and graduated from the Chapin Collegiate School of New York. As a boy, in 1879, he entered the employ of the passenger department of the C. R. R. of N. J., and in 1887 was made chief clerk. In 1901 he was appointed assistant general passenger agent, in which position he remained until the recent appointment as general passenger agent of the system. Mr. Hope's long service will

Mr. J. F. Leake has been appointed master car builder of the Southern Railroad, vice Mr. A. Armstrong, assigned to other duties.

Mr. W. Whitaker has been appointed assistant engineer of the Norfolk & Western system at Toledo, O.

Mr. H. J. Shaw has been appointed assistant division engineer of the Pennsylvania lines west, at Toledo, Ohio, vice H. Eichler, resigned.

Mr. B. P. Meyers has been appointed master mechanic of the International & Great Northern at Taylor, Tex., vice Mr. C. M. McLain, resigned.

Mr. F. S. Irvine has been appointed to the new office of right of way engineer in the real estate department of the Pennsylvania Lines West.

Mr. T. H. Williams has been appointed general foreman of the Southern Railroad Shops at Knoxville, Tenn., vice Mr. C. H. Lewis, resigned.

Mr. T. P. Anderson, has been appointed superintendent of tests of the Cincinnati, New Orleans & Texas Pacific, with headquarters at Lexington, Ky.

Mr. G. A. Gallagher has been appointed master mechanic of the Southern Indiana Railway, with headquarters at Bedford, Ind., vice Mr. W. C. Walsh, resigned.

Mr. W. Kells, master mechanic of the Lehigh Valley at Sayre, Pa., has been transferred to East Buffalo, N. Y., in a similar capacity, vice Mr. F. R. Cooper, resigned.

Mr. A. L. Graburn has resigned as superintendent of shops of the Great Northern at St. Cloud, Minn., to engage in the railway supply business at St. Paul, Minn.

Mr. T. F. Drefus has been appointed superintendent of motive power of the Buffalo & Susquehanna, with headquarters at Galeton, Pa., vice Mr. C. R. Williams, resigned.

Mr. M. J. McGraw, master mechanic of the Missouri Pacific, at Fort Scott, Kan., has been transferred as master mechanic to St. Louis, Mo., vice Mr. L. Bartlett, transferred.

Mr. S. K. Dickerson has been appointed assistant superintendent of motive power of the Lake Shore & Michigan Southern Railway, vice Mr. Le Grand Parish, promoted.

Mr. W. W. Breckenridge, master mechanic of the Great Northern at Crookston, Minn., has been transferred to Great Falls, Mont., in a similar capacity, vice Mr. F. M. Fryburg, promoted.

Mr. C. M. Burt, formerly general passenger agent of the Central Railroad of New Jersey, has accepted a similar position with the Boston & Maine. Mr. Burt's headquarters will hereafter be in Boston, Mass. Although yet a young man, Mr. Burt has had 25 years' experience in railroad work. He began in the auditor's office of the New York, Pennsylvania & Ohio, familiarly known as the "Nyp and O." In 1882 he gave up railroading and for a short time took a position in the United States Quartermaster's Department, but by the end of the year he became a railroad man again and was employed by the West Shore as rate clerk. In 1888 he became chief rate clerk in the Trunk



W. C. HOPE.



C. M. BURT.

stand him in good stead in his new position, and his many friends look forward to a very successful career for him.

The office of the master mechanic of Midland Valley has been removed from Fort Smith, Ark., to Muskogee, I. T.

Mr. H. S. Rogers has been appointed engineer of maintenance of way and construction of the Illinois, Iowa & Minnesota.

Mr. Herbert Riddle has been appointed night roundhouse foreman of the Denver & Rio Grande shops at Salida, Colo.

Mr. F. Paul has been appointed engineer of tests of the Cincinnati, New Orleans & Texas Pacific, with headquarters at Lexington, Ky.

Line Passenger Association and later held the same position in the Joint Passenger Association. In 1899 Mr. Burt became general passenger agent of the Fitchburg Railroad and later, when this line was absorbed by the B. & M., he became assistant passenger agent of that road. Later he took the position of general passenger agent for the C. R. R. of N. J., and now leaves that line to become the general passenger agent of the Boston & Maine.

Mr. F. M. Edwards, resident engineer of the Southern, at Chattanooga, Tenn., has been appointed engineer of maintenance of way at Birmingham, Ala., vice Mr. P. S. Fitzgerald, resigned.

Mr. W. T. Noonan, former general superintendent of the Buffalo, Rochester & Pittsburgh, has been appointed gen-

eral manager, and the position of general superintendent has been abolished.

Mr. C. L. Harris, formerly assistant superintendent of the Southern Railway, has been appointed superintendent of the Knoxville division of the same road, vice Mr. Loyall, promoted.

Mr. Andrew M. McGill has resigned as general foreman of the mechanical department of the New York, New Haven & Hartford, to become master mechanic on the Lehigh Valley Railroad at Snyer, Pa.

Mr. W. J. Toleron, of Pocatello, Idaho, has been appointed superintendent of motive power of the Southwestern Choctaw division of the Chicago, Rock Island & Pacific, at Topeka, vice Mr. T. Roope, resigned.

Mr. G. R. Loyall, formerly division superintendent of the Knoxville division of the Southern Railway, has been appointed assistant general superintendent of the Middle District, with office at Knoxville, Tenn.

Mr. C. E. Carson has been appointed superintendent of Kansas City Terminals, vice Mr. E. K. Carnes, resigned. The Terminal includes the Missouri Pacific, the St. Louis, Iron Mountain & Southern and the leased, operated and independent lines.

Mr. C. A. Henry, master mechanic of the Columbus shops of the Pittsburgh, Cincinnati, Chicago & St. Louis, has been appointed assistant superintendent of motive power. He will be succeeded by Mr. P. F. Smith, master mechanic of the shops at Dennison.

Mr. N. M. Loney, assistant engineer of motive power of the Northwest System of the Pennsylvania Lines, at Fort Wayne, Ind., has been appointed master mechanic of the Northwest System, with headquarters at Chicago, succeeding Joseph J. Walsh, transferred.

Mr. H. H. Scovil has recently been appointed sales agent of the Latrobe tire department in the Chicago office of the Railway Steel Spring Company, of New York. Mr. George M. Burns has been appointed general sales agent of the St. Louis office of the same company.

Mr. E. D. Bronner, who was lately appointed superintendent of motive power of the L. S. & M. S., has been transferred to the position which he has so long and ably held, that of superintendent of motive power of the Michigan Central, at Detroit. This transfer was made at Mr. Bronner's own request and was necessitated by the continued illness of a member of his family.

Mr. Charles W. Haight, a locomotive engineer on the Delaware, Lackawanna & Western, was recently presented with a medal of honor by President Roosevelt, in accordance with the act of Con-

gress establishing this distinction. Haight saved the life of a child by climbing out on the pilot of his engine and pulling the little one clear, from between the rails, while the train was moving.

Mr. George H. Williams was recently given a medal of honor by the President of the United States as the recognition established by Congress for heroism displayed in connection with railroad work. Williams dashed in front of a moving train and saved a woman from a terrible death. The rescuer, who is an engineer on the New York Central, was thrown down and hurt while performing this act of bravery.

Mr. LeGrand Parish was appointed superintendent of motive power and equipment of the Michigan Central on July 23 last and has now been appointed superintendent of motive power of the Lake Shore & Michigan Southern, the Lake Erie & Western, the Lake Erie Alliance & Wheeling and the Dunkirk Allegheny Valley & Pittsburg, with headquarters at Cleveland, Ohio, vice Mr. E. D. Bronner, transferred.

Mr. Lewis G. McNab has been successful in winning the Grand Trunk scholarship, which covers four years' tuition in the faculty of applied science at McGill University, at Montreal. Mr. McNab is 17 years of age. He has just graduated from the High School, and is a son of Mr. William McNab, assistant engineer of the Grand Trunk, and who is also a director of the American Railway Engineering and Maintenance of Way Association, a well-known member of the Canadian Society of Civil Engineers, and president of the Caledonian Society of Montreal. The scholarship is open to apprentices and other employees of the Grand Trunk under twenty-one years of age, and also to sons of regular employees, and it was under this head that Mr. McNab entered.

#### Obituary.

Charles Addison Bragg, district office manager of the Westinghouse Electric & Mfg. Company, Philadelphia, Pa., died recently after an illness of over two months' duration. Mr. Bragg was one of the pioneers in the electrical business, having been associated with the United States Electric Lighting Company as early as 1882. His connection with the Westinghouse Electric & Mfg. Company began in the year 1889, when he was made the manager of the Philadelphia office, which position he filled successfully up to the time of his death. Mr. Bragg possessed a most genial disposition, which endeared him to all with whom he came in contact. He was born and brought up in Franklin county, Mo. Following his early education, he attended Yale College, from which he graduated. He was 56 years old. Mr. Bragg is survived by his wife and one daughter.

#### Westinghouse Electric Company.

The Westinghouse Electric and Manufacturing Company, of Schenectady, N. Y., have issued a very important report covering a period of six years and showing the phenomenal growth of the company's operations in that period. There are now about 15,000 employees exclusive of the selling organization. The chief works are at East Pittsburgh, where there is a line of railway to Trafford City owned by the company and furnished with the third rail and adequate appliances for testing electric locomotives using direct current. Mr. L. A. Osborne, vice-president, in reporting on behalf of the Engineering Department gives great credit to Chief Engineer, Mr. B. G. Lamme, whose masterly application of the single phase system furnishes the most economical use of electric power on railways. In addition to the company's works at East Pittsburgh they operate an extensive foundry at Cleveland and another at Allegheny, and are extending their works at Newark and have purchased a large property at Watessing, N. J., where the manufacture of incandescent lamps will be conducted. Branch works are already in operation in London, Paris and Berlin, and the company's operations are already the largest of their kind in the world. It may be added that the sales for the present year will exceed \$34,000,000.

#### Graphite Brushes.

Dixon's Graphite Brushes, for electrical machines are coming into great popular favor. Their superiority over the ordinary carbon brushes has been claimed by all who have given them a fair trial. The lubricating quality of the graphite brushes is an important advantage immediately apparent, while in comparison with many makes of brushes the graphite brush is soft, and all that is necessary is that the commutator on which they are to be used should have a true and polished surface in order to insure uniform contact. Send for a copy of their new catalogue and it will be mailed to you by the Joseph Dixon Crucible Co., Jersey City, N. J.

#### Railway Record in Connecticut.

It appears from reports compiled by the Board of Railroad Commissioners of the State of Connecticut for the year ending June 30, 1905, that there were 64,403,147 passengers carried on the steam railroads, without the loss of a single life, and that only 36 passengers were injured. The average length of each passenger trip was 18.51 miles.

### Steel Passenger Coach.

The Southern Railway have recently received some steel passenger cars from The Pressed Steel Car Company of Pittsburgh, Pa. One of these cars was exhibited at the meeting of the M. M. and M. C. B. Associations at Atlantic City this summer.

The cars are of the same general size as the standard coaches of the Southern Railway, and the interior arrangement of seats, smoking room and saloons as well as the general appearance of the car conforms to the company's standard. In equipment, specialties, etc., the same rule has also been followed wherever practicable, so as to facilitate repairs and interchangeability. The underframe, superstructure, platforms, platform sills, body carlines and the side sheets of the cars on the outside below the windows are made of steel in the form of plates, pressed, rolled or built-up parts, according to the requirements and the adaptability of the material. The interior finish,

tom. The main post consists of two angles spaced apart, and the intermediate posts consist each of one T-shape. The main post extends from bottom of side plate to roof, but the intermediate posts extend from roof to window sill only, at which point they are riveted to a reinforcing plate extending between the main post inside of the side sheets. The floor is composed of  $\frac{1}{8}$ -in. steel plates upon which are laid two courses of wooden flooring, each  $\frac{3}{4}$ -in. thick with  $\frac{1}{8}$ -in. felt paper between. The top of the floor is covered with  $\frac{3}{8}$ -in. thick linoleum. The platforms are supported on the center sills and on 6-in. channels. The platform end-sills are steel plate,  $\frac{5}{8}$ -in. thick, pressed into channel shape and to suit vestibule fixtures. All vertical lines of rivets on the outside of the car are covered with special drawn steel mouldings, which give the appearance of broad panels.

The construction of these cars has been worked out by the Pressed Steel

$10\frac{1}{4}$  ins.; width inside between finish, 8 ft.  $10\frac{1}{4}$  ins.; height from top of rail to top of body, 14 ft. 2 ins. The car is also equipped with Westinghouse high speed automatic air brakes, Buhoup 3-stem couplers, Gold car heating system. Also one 16 "D" stove, McCord journal boxes. Lighted by the Pintsch System and Buhoup, wide vestibule platforms.

### Baldwins and the Santa Fe System.

A record of recent construction of locomotives at the Baldwin Locomotive Works is published in a beautifully illustrated catalogue (No. 56) and comprises twenty-five photographs and other views of locomotives chiefly built for the Atchison, Topeka and Santa Fe Railway System. The illuminated letter press description presents in an interesting way the history of the Santa Fe system, which occupies a prominent position among the great railways of the United States. The growth of the system has been rapid and continual since the main line was opened for traffic in 1873, beginning at Atchison, Kansas, and extending to the western

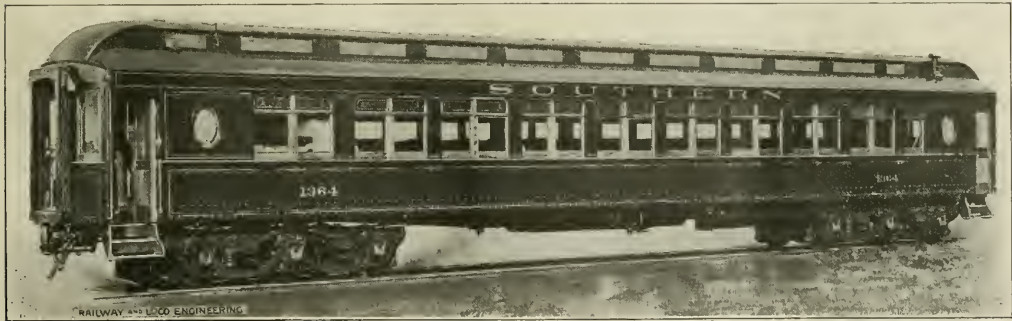

STEEL PASSENGER COACH FOR THE SOUTHERN.

A. Stewart, Mechanical Superintendent.

Pressed Steel Car Co., Builders.

doors, windows, window sash, upper part of floor, roof, and the outside above the window sills is made of wood.

The underframe is composed of two fish belly center sills built up of  $\frac{3}{4}$ -in. plates, 22-in. deep at the center and  $13\frac{1}{4}$  ins. over the bolster. These plates are reinforced with angle irons and cover plates and extend throughout the length of the car between the platform sills. The body bolsters, spaced to suit six wheel trucks, consist of  $\frac{1}{2}$ -in. plates  $13\frac{1}{4}$  ins. deep near the center sills, tapering toward the sides and reinforced with T-irons and cover plates on top and bottom. The side bearings are supported on 8 ins. I-beams, secured between the bolsters.

The underframe consists of two deep and eight shallow diaphragms on each side of the car between the bolsters. The deep diaphragms are made up of  $\frac{1}{4}$ -in. plates,  $20\frac{1}{2}$  ins. deep at center sills and they are reinforced with T-irons and cover plates on top and bot-

tom. The main post consists of two angles spaced apart, and the intermediate posts consist each of one T-shape. The main post extends from bottom of side plate to roof, but the intermediate posts extend from roof to window sill only, at which point they are riveted to a reinforcing plate extending between the main post inside of the side sheets. The floor is composed of  $\frac{1}{8}$ -in. steel plates upon which are laid two courses of wooden flooring, each  $\frac{3}{4}$ -in. thick with  $\frac{1}{8}$ -in. felt paper between. The top of the floor is covered with  $\frac{3}{8}$ -in. thick linoleum. The platforms are supported on the center sills and on 6-in. channels. The platform end-sills are steel plate,  $\frac{5}{8}$ -in. thick, pressed into channel shape and to suit vestibule fixtures. All vertical lines of rivets on the outside of the car are covered with special drawn steel mouldings, which give the appearance of broad panels.

The construction of these cars has been worked out by the Pressed Steel Car Company subject to the approval, concerning important parts, of Mr. A. Stewart, mechanical superintendent, and Mr. R. L. Ettinger, Consulting Mechanical Engineer, both of the Southern Railway, and while the construction as a whole, as well as in detail, may be more or less changed in similar cars, built hereafter, this one indicates that a step has been taken in the right direction, producing a car offering greater resistance to damage in accidents as well as minimizing danger to passengers in such emergency. The Pressed Steel Car Company is preparing drawings of other advanced types of steel passenger coaches and steel trucks, and these are to embody the use of non-inflammable or totally fireproof materials.

Some of the principal dimensions are as follows:  
Length over platforms, 74 ft.  $6\frac{1}{4}$  ins.; length over body end sills, 56 ft.; total inside length, 65 ft.  $3\frac{1}{4}$  ins.; distance from center to center of trucks, 50 ft.; width over side sheets, 9 ft.

boundary of the State, a distance of 470 miles. The company now control 9,321 miles of railways. A double daily service is now maintained between Chicago and San Francisco and takes rank as being among the finest trains in the world. The distance approaches 2,600 miles, and the running time is 3 days and 4 hours, the road crossing three extensive mountain ranges of great altitude.

Since the beginning over 1,000 locomotives have been furnished to the company by the Baldwin Locomotive Works. The first engines built were of a type that was used on all classes of traffic and weighed about 30 tons. They had a four wheel truck in front with four driving wheels and for the mixed passenger and freight traffic of that period were very serviceable engines. Stronger locomotives were found necessary when the Southern Pacific division of the line was opened and grades of over 300 feet per

mile had to be climbed. The first of the consolidation and ten wheel engines then appeared. They weighed about 60 tons and with the first and third drivers having plain tires these engines could readily round the sharpest curves.

In the early '80's the necessity for still larger locomotive became greater with the rapidly increasing volume of transportation and previous to 1890, over one hundred ten wheel locomotives for both passenger and freight service were supplied to the system, besides a num-

ber of six wheel switching engines. In 1898 the first engines built with cast steel frames were furnished to the company by the Baldwin Locomotive Works. The weight of the locomotives had now reached to 80 tons and it was then thought that the limit of weight had been reached, but in the meantime a rapid development in the weight and power of heavy freight locomotives was taking place. The balanced compound was coming into favor and of

and 54 minutes, averaging 50.4 per hour. This feat is not rivalled by any record of long distance running, and reflects the highest credit on the enterprise of the railway company and the admirable constructive ability of the Baldwin Works. A copy of this pamphlet may be had on application to the builders.

The Watson-Stillman Company, of New York, have just issued a new catalogue No. 69, dealing with railroad hydraulic tools both for street car and steam railroad work. It therefore supersedes their former issues Nos. 52 and 53. Among the many beautifully illustrated and clearly described jacks and presses, is an hydraulic jack with independent pump not previously published. There are many situations where it is inconvenient to work the lever of a jack because of lack of room. These conditions are met

by the jack which is broad-based, compact and strong and which has a flexible metal pipe connecting the pump to the jack. The jack may be placed in a cramped position and the operator may stand at a convenient distance with the pump and easily operate the jack. This tool is made in many and various sizes. A new pulling jack for hoisting or pulling heavy weights in engine rooms or other places is shown on page 22. A new special hydraulic telescope car jack appears on page 28. Two new tools are illustrated on pages 66 and 67, being respectively a swivel beam crank pin press and a motor driven crank pin press. New matter has been added on pages 70-71; and on pages 74-75-76-77 there are shown some new types of wheel presses made with 4 rods and designed with the idea of being able to take the strains more evenly than can be done with ordinary flat 2-rod press. Pages 81 and 82 show tools which have hitherto appeared in this company's catalogues or in illustrated notices. The one on page 83, which is a portable shaft straightener for lathes has had five new sizes added. The company will be happy to send a copy of this catalogue to anyone who applies to them for one, and a perusal of it will not only be found very interesting but instructive as well.



## Here She Comes!

Just finishing her run having made every station on schedule time. And her bearings and pins are cool as cucumbers.

This is the kind of record every engineer can turn in who uses Dixon's Flake Graphite on his engine. Hot pins and bearings, and delays due to friction troubles of any kind, absolutely will not occur if Dixon's Graphite is judiciously used.

To each and every one who doubts this fact, or wants to see it proven, we desire to send a liberal free sample and Booklet 69-C, which tells how and where to use Dixon's Graphite.

**JOSEPH DIXON  
CRUCIBLE CO.  
Jersey City, N. J.**

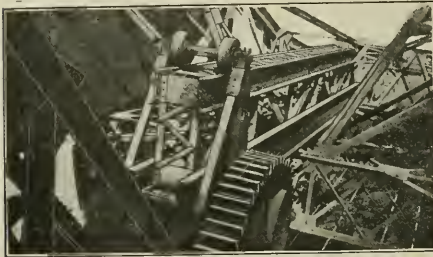

RACK FRAME FOR LIFTING ROLLER BRIDGE OVER  
NEWARK BAY—C. R. R. OF N. J.

ber of six wheel switching engines. In 1898 the first engines built with cast steel frames were furnished to the company by the Baldwin Locomotive Works. The weight of the locomotives had now reached to 80 tons and it was then thought that the limit of weight had been reached, but in the meantime a rapid development in the weight and power of heavy freight locomotives was taking place. The balanced compound was coming into favor and of



ROLLER OF BRIDGE AND COUNTERWEIGHT—C. R. R. OF  
N. J., NEWARK BAY.

these 137 have been built by the Baldwin Company for the Santa Fe system. The total weight of engine and tender is about 180 tons. It may be added that a large number of these engines are burning oil with the most gratifying results. Some of the special runs made by the Baldwin engines are the most notable on record, among the latest being the Scott special, which ran from Los Angeles, Cal., to Chicago, Ill., a distance of 2,265 miles in 44 hours



# "J. M."



## RAILROAD SUPPLIES

### OUR NEW CATALOG

of "J.-M." Asbestos and Magnesia Railroad Supplies is now ready for distribution. This is the most complete catalog of its kind devoted entirely to Railroad Materials.

WRITE FOR CATALOG  
NO. 250-A TO-DAY

### A Few J.-M. Products

- Smoke Jacks
- "Transite" Fireproof Lumber
- Asbestos and Magnesia Locomotive Lagging
- "Vulcabeston" Pump Packing
- "Vulcabeston" Gaskets
- "Vulcabeston" Rope Packing
- Train Pipe Covering
- "Kearsarge" Gaskets
- All grades of Asbestos and Magnesia Pipe Covering
- Hair Felt
- "Keystone" Hair Insulator
- Asbestos Cements
- "Retort" Cements
- "Canadax" Wick Packings
- High Pressure Asbestos Packing
- Asbestos Roofing
- Portland Sectional Conduit

### H.W. JOHNS-MANVILLE CO.

Manufacturers of Asbestos and Magnesia Products, Asbestos Roofings, Packings, Electrical Insulating Materials, "Noark" Fuse Devices, Electric Railway Supplies, etc.

NEW YORK	ST. LOUIS	MINNEAPOLIS
MILWAUKEE	PITTSBURG	DALLAS
CHICAGO	CLEVELAND	SAN FRANCISCO
BOSTON	NEW ORLEANS	LOS ANGELES
PHILADELPHIA	KANSAS CITY	SEATTLE
	LONDON	

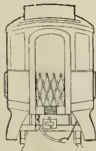

### Semi-Plug Valves.

Engine No. 111 of the Buffalo & Susquehanna Railroad, has a record performance of valves. The valves are the Semi-plug type made by the American Balance Valve Company of Jersey Shore, Pa. The engine made 91,000 miles in regular service with no appreciable wear of valves or cages. On the 11th of last July this engine had been in continuous service, except, of course, when laid up for repairs, for five years, and the valves are at this time reported to be absolutely steam-tight and to all appearances the same as when first applied. That means five years without re-boring the valve cage. The secret of this is said to be the control of the frictional contact of the Snap rings against the valve chamber.

One of the points about this valve is that there is a Wide ring interlocked into the Snap rings between them. This Wide ring keeps the Snap rings parallel with each other when the central Wedge ring is collapsed, as in drift-

practically frictionless plug valve with the automatic adjusting Snap ring.

The reason why this valve is called a "Semi-plug" Valve is because while working under steam the Snap rings are locked by the steam pressure, preventing their expansion by steam, which is underneath them, and therefore the

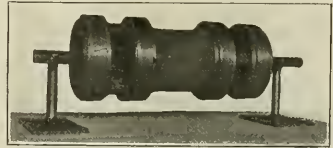

DOUBLE HEAD SEMI-PLUG VALVE

rings are practically converted into plugs. When the valves are working without steam pressure, the Snap rings are at liberty to adjust themselves to the cage, the same as ordinary Snap rings do. The valve is, therefore, a plug while working under steam, but a

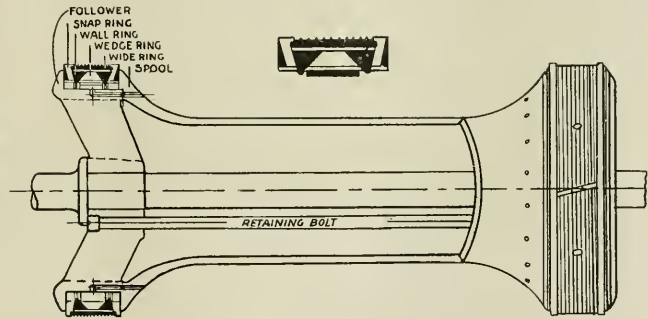

SECTION OF THE SEMI-PLUG VALVE.

ing; it also compels the two Snap rings to expand or contract together, and this supplies a means of passing over steam ports, when the engine is drifting, without allowing the Snap ring to spring into the port.

Now when the valve is working under steam, the pressure by the system of cones made by beveling the sides of the

Snap-ring valve while without steam, and is therefore described as a "Semi-plug" or half plug valve, being plug half the time and Snap ring the other half of the time according to the use of steam and the time steam is not on the valve.

In order to further demonstrate the fact that in this valve the contact of the Snap rings with the valve cage is absolutely controlled. A set of these valves was placed on an engine of the Pennsylvania Division of the New York Central under the direction of Mr. E. A. Walton, Div. Supt. of M. P., on July 1, 1905. The valves have, therefore, been in service over a year, the engine running night and day. The bridges in the steam ports of this engine were removed, and the valves allowed to pass over the ports without bridges. After a year's service the valves are reported to be in the same condition as when new, that is with no sign of a blow, and no perceptible wear of the valve cages, nor of the rings.

In order to have the valves steam-



TRIPLE HEAD SEMI-PLUG VALVE.

Snap rings and the solid Wall rings, convert it into a plug, and the rings remain that particular diameter in which they are fixed during the operation of the valve under steam, in that way preventing any wear of the rings. This also produces the very desirable result of minimum friction, and the result is a

tight and at the same time to secure minimum friction, thereby reducing the amount of lubrication, the plug valve system has been found desirable, causing the rings to act like plugs has been found to secure minimum wear of the cages. In addition to this the plug is automatic in its adjustment. By this

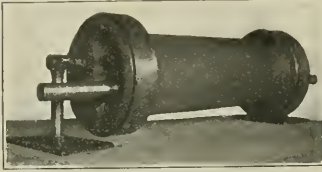

SEMI-PLUG VALVE AFTER ONE YEAR OF SERVICE.

means the cage remains true in its wear. This is secured by the automatic adjustment of the Snap rings and the locking feature, which operates while under steam.

The company have issued a catalogue dealing with piston valves in which a more detailed description of the semi-plug valve can be found. The company will be happy to send a copy of this pamphlet to any one who is interested enough to apply to them for one.

#### Six-Coupled Express Engine.

The Caledonian Railway, of which Mr. John F. McIntosh is locomotive superintendent, has lately turned out of their St. Rollox shops some six-coupled express passenger engines of the type illustrated in our engraving. The cylinders are 20x26 ins., the

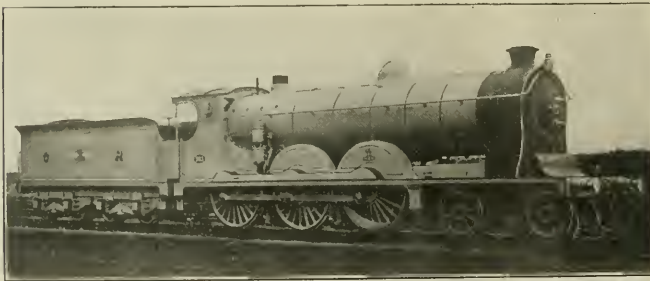

CALEDONIAN RAILWAY 4-6-0 EXPRESS ENGINE.

drawing wheels are 78 ins. in diameter and the boiler pressure is 200 lbs. per sq. in. The weight in working order is about 73 tons.

Speaking of this locomotive Mr. McIntosh says: "No trouble has been spared in increasing the dimensions of the bearings, which are for the driving axle is 9½ ins. diameter by 10½ ins. long and for the intermediate and trailing, which are concave journals, 8 ins. diameter in the center, 9½ ins. diameter at the ends, and 12 ins. long. The big-end

bearing is 9½ ins. diameter by 4¾ ins. long. It has been designed for the purpose of eliminating the possibility of heating.

A variation on the previous standard design, is the provision for ½-in. total side play on the trailing axle. This necessitates a knuckle joint in the trailing coupling rod. A better distribution of the weight has also been obtained by substituting a built up steel plate drag box in place of a cast iron one, and also by substituting direct stays in the crown of the fire box in place of the usual roof bars. The diameter of the boiler is 63½ ins., so as to give satisfactory heating surface and steam capacity. The tubes are 2 ins. external diameter throughout, and are of mild steel galvanized. The tubes are 16 ft. 8 ins. long. The fire box heating surface is 148.25 sq. ft.

The safety valves are of the double type, having 4 valves 4 ins. in diameter, with independent springs, which are set for a working pressure of 200 lbs. per sq. in. Under test the boiler has shown improved steaming power, probably due to the substitution of the direct stays for roof bars in crown of fire box, and also to an increased water space between the outer and inner fire box shells. The engine is equipped with the usual Westinghouse Brake fittings, and has also an Ejector and "through" pipes to enable it to work trains having the Vacuum Brake. The form of steam reversing gear used is the Caledonian standard pattern, which retains the use

of the reversing lever and notch-plate.

The following are some of the principal dimensions, etc.:

Boiler—Length of barrel, 17 ft. 7¾ ins.; thickness of barrel plates, 21/32 in.

Fire Box Shell—Length outside, 8 ft. 6 ins.; breadth outside at bottom, 4 ft.; depth from center at front, 5 ft.; back, 3 ft. 9 ins.; thickness of plates, sides, 5/8 in.; crown, ¾ in.; grate area, 26 sq. ft.

Tender—Capacity of tanks, 5,000 Imperial gals.; fuel space, 6 (long) tons; diameter of wheels, 3 ft. 6 ins.; weight of tender, full, 57 tons; weight of engine and tender in working order, 130 tons; length of engine and tender over buffers, 65 ft. 6 ins.

# GOLD Car Heating and Lighting Co.

Manufacturers of

**ELECTRIC,  
STEAM AND  
HOT WATER  
APPARATUS  
FOR RAILWAY CARS**

**EDISON  
STORAGE  
BATTERY  
FOR RAILWAY CAR  
LIGHTING**

Largest Manufacturers in the World  
of Car Heating Apparatus

Catalogues and Circulars  
cheerfully furnished

Main Office, Whitehall Bldg.  
17 BATTERY PLACE  
NEW YORK

# Homestead Valves

Straightway, Three-way and Four-way, and

# Homestead Locking Cocks

Are Famous the World Over

They cost more, but are worth very much more than other makes. You try them and see.

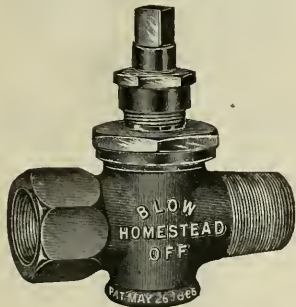

Brass, 1 1/4 in., \$5.00 net

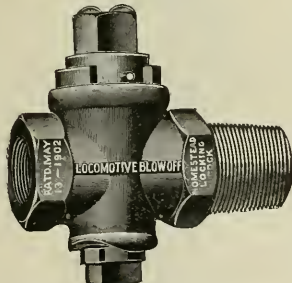

Iron Body, Brass Plug, 1 1/4 in., \$4.00 net

## Homestead Valve Mfg. Co.

WORKS, HOMESTEAD, PA. PITTSBURG, PA.

## American Locomotive Sander Company

13th & Willow Sts., Philadelphia, Pa.

Proprietors and Manufacturers

LEACH, SHERBURNE, DEAN, HOUSTON, "SHE" and CURTIS SANDERS

### THE ROBERT W. HUNT & CO.

Bureau of Inspection, Tests and Consultation, 1137 THE ROOKERY, CHICAGO.

66 Broadway, New York. Park Building, Pittsburgh. 31 Norfolk House, London, Eng.

Inspection of Steel Rails, Splice Bars, Railroad Cars, Wheels, Axles, etc. CHEMICAL LABORATORY—Analysis of Ores, Iron, Steel, Oils, Water, etc. PHYSICAL LABORATORY—Test of Metals, Drop and Pulling Test of Couplers, Draw Bars, etc.

Efficiency Tests of Boilers, Engines and Locomotives.

### Rehabilitating an Old Tool.

Our line illustrations show an old vertical spindle milling machine, out of the running as a miller, yet doing good work in the Columbus, Ohio, shops of the Pennsylvania Lines, boring driving boxes. The machine originally had tables set at right angles to each other,

speeds for this kind of work, as most of the time required in finishing the boxes is taken in setting them. The clutch lever shown in the illustration operates both the brake and clutch. We are indebted to Mr. D. F. Crawford, general superintendent of motive power, for the prints from which our engravings are made.

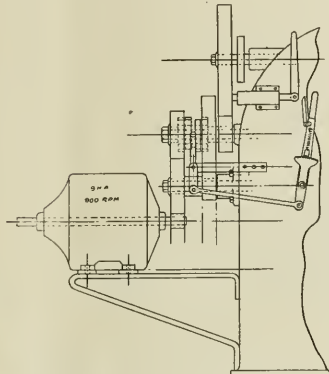

MOTOR DRIVE ARRANGEMENT ON CONVERTED MACHINE.

er, and also the ordinary circular motion. The machine was out of date for its original purpose as it was too light, and the work done on it became too expensive. Driving box work in the shop began to go behind on account of its being done on a horizontal boring machine which was not stiff enough to do heavy and quick work. In looking around for a machine which would be more suitable, one of the assistant foremen in the machine shop suggested that as the old milling machine was practically of no use for the work it was originally designed to do, it would serve a better purpose if modified for driving boxes. This suggestion was adopted and the necessary changes were made, and it became a very satisfactory machine. One peculiarity is that it has but one feed, and this is 1/4 in. per revolution. Two tools are provided in the cutter bar, so that each tool removes 1/2 in. of material. The original method of driving the machine was unsatisfactory, and a motor was applied to it. This method of driving gives two speeds instead of one. It has not been found necessary to have more than two

### Punctuality and Capability.

Not only is punctuality a bright star in the constellation of industry, but the lack of it is a real hindrance to progress in every walk of life. In every department of railroad work it is particularly essential and is second only to capability. Both qualities can be cultivated to a high degree. In the former the individual must evolve the quality out of his own inner consciousness. In the latter and more important qualification of the two, ignorance can only be overcome by study, whose essential requisite is instruction either from qualified masters or well written books. Right here, RAILWAY AND LOCOMOTIVE ENGINEERING supplies the necessary adjunct. Its pages are filled with the expression of the best thoughts of the leading railroad men of our time. It has met the universal approval of the leading railway men throughout the world. The price, \$2 a year, places it within the reach of every railroad employee.

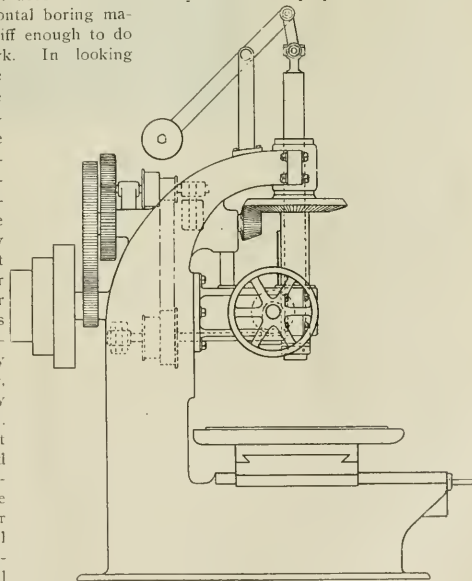

VERTICAL SPINDLE MILLING MACHINE, CONVERTED.

"Twentieth Century Locomotives," Angus Sinclair Co., deals comprehensively with the design, construction, repairing and operating of locomotives

and railway machinery. First principles are explained. Steam and motive power is dealt with; workshop operations described. valve motion, care and management of locomotive boilers, operating locomotives, road repairs to engines, blows, pounds in simple and compound engines; how to calculate power, train resistance. resistances on grades, etc. Shop tools explained. Shop recipes, definitions of technical terms, tables, etc. Descriptions and dimensions of the various types of standard locomotives. The book is well and clearly illustrated and is thoroughly up to date in all particulars, fully indexed. Price, \$3.00.

"Locomotive Engine Running and Management," by Angus Sinclair, is an old and universal favorite. A well-known general manager remarked in a meeting of railroad men lately, "I attribute much of my success in life to the inspiration of that book. It was my pocket companion for years." Price, \$2.00.

"Practical Shop Talks." Colvin. This is a very helpful book, combining instruction with amusement. It is a particularly useful book to the young mechanic. It has a stimulating effect in inducing him to study his business. We sell it for 50 cents.

"Examination Questions for Promotion." Thompson. This book is used by many master mechanics and traveling engineers in the examination of firemen for promotion and of engineers likely to be hired. It contains in small compass a large amount of information about the locomotive. Convenient pocket size. We cordially recommend this book. It sells for 75 cents.

The 1904 Air Brake Catechism. Conger. Convenient size, 202 pages, well illustrated. Up to date information concerning the whole air brake problem, in question and answer form. Instructs on the operation of the Westinghouse and the New York Air Brakes, and has a list of examination questions for enginemen and trainmen. Bound only in cloth. Price, \$1.00.

"Compound Locomotives." Colvin. This book instructs a man so that he will understand the construction and operation of a compound locomotive as well as he now understands a simple engine. Tells all about running, break-downs and repairs. Convenient pocket size, bound in leather, \$1.00.

"Catechism of the Steam Plant." Hemenway. Contains information that will enable a man to take out a li-

cense to run a stationery engine. Tells about boilers, heating surface, horse power, condensers, feed water heaters, air pumps, engines, strength of boilers, testing boiler performances, etc., etc. This is only a partial list of its contents. It is in the question and answer style. 128 pages. Pocket size, 50 cents.

"Care and Management of Locomotive Boilers." Raps. This is a book that ought to be in the hands of every person who is in any way interested in keeping boilers in safe working order. Written by a foreman boilermaker. Also contains several chapters on oil burning locomotives. Price, 50 cents.

"Locomotive Link Motion." Halsey. Any person who gives a little study to this book ceases to find link motion a puzzle. Explains about valves and valve motion in plain language. Price, \$1.00.

#### Flexible Staybolts.

The Flannery Bolt Company of Pittsburgh, have just issued an artistic and finely illustrated catalogue showing the

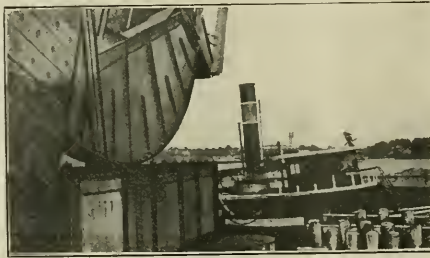

ROLLER BRIDGE LIFTED. TUG GOING THROUGH CHANNEL, NEWARK BAY, C. R. OF N. J.

application of the Tate flexible staybolts to a variety of boilers. The letter press descriptions are valuable, as showing the high degree of efficiency which the use of the flexible staybolts has maintained in boilers, while the illustrations show the installations from which the best results have been obtained. The general use of the flexible staybolt eliminates the cracking of sheets or breaking of staybolts in any kind of boiler and numerous testimonials are quoted as to the admirable features of the work of the Flannery Bolt Company. The catalogue may be had by application to the company.

#### Boltless Trucks.

Not long ago a company was formed by Mr. Wilson E. Symons for the purpose of manufacturing steel car and engine trucks. The company is a Chicago concern, known as the Pioneer Cast Steel Truck Company, with offices in the Postal Telegraph Building. Mr

## Locomotive Blow-Off Plug Valves

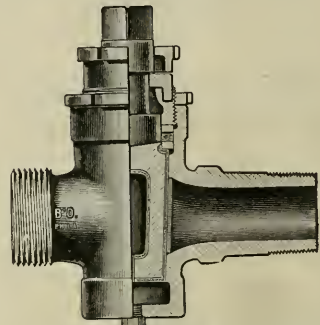
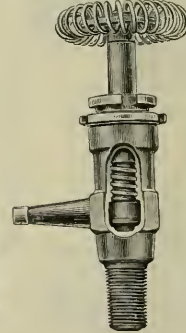

Fig. 9

All Brass, extra heavy, with Cased Plug. For 250 lbs. pressure.

Made with Draining Plug to prevent freezing.

## Locomotive Gauge Cocks



For High Pressure

Bordo Self-Grinding Gauge Cocks, made with renewable Hard Bronze Disc. Opened and closed with a quarter turn. Guaranteed Steam tight under the most exacting conditions. Shanks Threaded to specifications for Locomotives.

Fig. 23, with Wheel.

## Swing-Joints and Pipe Attachment

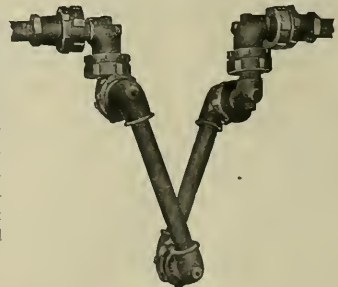

Fig. 33.

May be applied between Locomotive and Tender.

These Swing-Joints are suitable for Steam, Gas, Air, Water or Oil.

Complete Booklet on Application

**L. J. BORDO CO.**  
PHILADELPHIA, PA.

# Tate Flexible Staybolt



Strong  
Effective  
Economical

Flexibility  
Durability  
Simplicity

Holds firebox sheets securely together, and accommodates itself to the unequal expansion of the plates.

## FLANNERY BOLT COMPANY

PITTSBURG, PA., U. S. A.

Suite 308, Frick Bldg.

B. E. D. STAFFORD, - - General Manager

Write us for Reference Book

Symons is president and Mr. E. M. Hadley is secretary and treasurer. Other railway specialties will be handled by this company.

Operating under patents secured by Mr. Symons in 1900 and following years, the Pioneer truck and the Revo truck are now on the market. Both of these trucks are made of cast steel and the feature about them which at once strikes the observer is the fact that they do not have any bolts, and there is nothing to shake loose.

The truck sides are cast in one piece, that of the Pioneer having a curved top,

opening in the truck sides. Excessive lateral motion of the bolster is prevented by two flanges cast on the bolster and which are inside the cast steel frames or truck sides. To make assurance doubly sure, there is a key driven through a suitable opening in the bolster outside the frames, and removable chafing plates are also keyed to the frames, and on these the sides of the bolster at the ends, rub. The bolster rests upon four coil springs at each end.

The Revo truck is designed for cars having a low floor level or low gravity

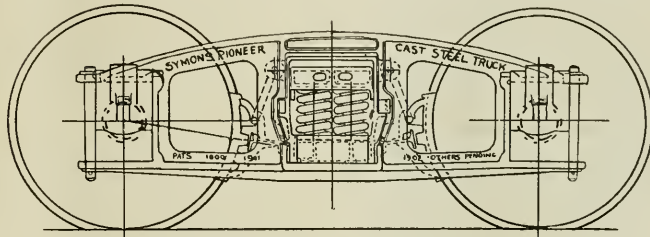

SIDE VIEW OF THE PIONEER TRUCK.

and a couple of what may be called horizontal jaws at each end which receive the axle boxes. These jaws pass above and below the box and correspond to the ends of the arch and tie bars of an ordinary diamond truck. The ends of the cast steel jaws are made with one oblong hole in each, and the box is held in place by a taper key which is dropped into these holes and driven down until the flat side of the key bears upon the outer surface of the box. The key

line, and the lower flange of the truck frame is curved downward, and the upper flange is horizontal. The spring plank is composed of two angle irons, and the boxes and chafing plates are keyed in position as in the Pioneer truck.

The removal of wheels from either of these trucks is a simple matter. After the weight of the car is taken off the truck by use of a pair of jacks, the truck frame can be supported on a pair of car repairers' short jacks and the

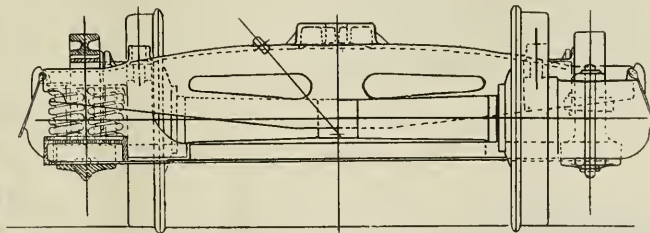

END VIEW OF THE PIONEER TRUCK.

is crosspinned at the bottom to prevent it slacking back, and the box is thus held firmly in the ends of the cast steel truck sides.

The members which correspond to the spring plank are angle irons riveted at their ends to the bottom flange of the truck sides, and these angles hold the truck sides rigidly together. The plan of truck sides and angles resembles the letter H, with the cross line of the letter corresponding to the two angle irons.

The bolster is also a cast steel piece, the ends of which pass in through the

taper key at the outside box removed and the box readily comes out, and at once releases the wheels. The design of the trucks is substantial, there are few parts, and the keys are made with large bearing surfaces and when securely pinned in place cannot work loose.

### Files and Rasps.

The American makers of files and rasps have long rivaled the best in the world, and the G. & H. Barnett Co., of Philadelphia, worthily sustain the reputation of American makers of files. It

## Q & C= Priest Snow Flanger



Order now for FALL and WINTER deliveries. Will keep your tracks clear, avoiding LARGE PLOWS and EXTRA CREWS.

Quincy, Manchester, Sargent Co.  
CHICAGO NEW YORK

## SKAT

is a soft soap sold in a neat lithographed can. When you wash up with SKAT, it gets into the crannies and "hard to reach" corners of your hands and the results are surprising. That's where the dirt lurks and hard soaps won't go. That's why SKAT is so popular. SKAT is made of the best materials, is absolutely pure and guaranteed to give you perfect satisfaction. You'll use it every day and like it more each time.

We can tell you where to buy SKAT, or better still show you how to sell it. If SKAT is not for sale in your locality, let us give you the selling right. Drop us a postal and get a free sample.

SKAT MFG. COMPANY  
Hartford Conn.

A Practically  
Perfect  
Portable  
Pneumatic

## PUNCH

Stop moving your heavy work to the machine. One Man brings this tool to the work and punches it besides.

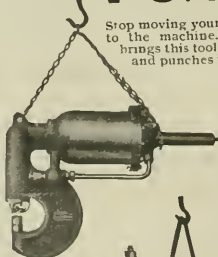

Punch Size B

Built in 5 Standard Sizes. Special machines built to order. Write for Catalogue C.

F. F. SLOCOMB & CO., Builders  
WILMINGTON, DEL.

**SAVES  
TIME  
LABOR  
SPACE**

Leading concerns in all parts of the country use this Punch.

would be difficult indeed to improve on their files and the Black Diamond trade mark is known in every machine shop in the land. The company have cleverly emphasized their trade mark by issuing a metal illuminated placard which is at once an elegant piece of work besides a very striking and artistic advertisement. The handsome placard has the distinguishing qualities of the company's work. It is made to last a long time.

### Fastest Trains of Two Continents.

The fastest train run on the American continent is on the Atlantic City Railroad, where 56.5 miles are covered in one hour. The railroad passes through a country that is nearly as flat as a billiard table, and no occasion for checking the speed is encountered. The average speed, as may be noted, is 56.5 miles an hour.

The fastest run made by any train in Europe is over a portion of the Caledonian Railway between Forfar and Perth, 32.5 miles, which is covered in 30 minutes, a rate of 65 miles an hour. The first part of the journey is over a level plain, through the Valley of Strathmore. At twenty miles out a steep descent of about 100 feet is made to the river Tay, succeeded by a sharp grade which leads to the top of an incline about six miles long that ends in Perth station.

### Homestead Valves.

The Homestead Valve Manufacturing Company, of Pittsburgh, Pa., has issued a neat pamphlet description of their specialties in valves. Their latest addition to their excellent product is an Anti-acid valve which has shown remarkable service, resisting the effects of sulphuric and other powerful acids. The company has earned a well deserved reputation in their valve work, the Homestead valve having many qualities peculiarly its own, particularly in the features of protecting the valve seat from wear while fluid is passing through and in the perfect balancing of the plug which is held in place by the pressure when open, and when closed it is locked in the seat by a patented wedging cam.

The Homestead Locomotive blow-off valve does not require any praise at our hands. Its merits are universally acknowledged, while their locking and angle valves of every variety of use and for varying degrees of pressure all bear testimony to the high class product of the Homestead Company.

It is amazing the number of Micawbers American life seems to develop. There is a large percentage of growing people who never can strike a fair ratio between their income and expenditure.

**WANTED — POSITION  
IN THE MECHANICAL  
DEPARTMENT  
OF A RAILWAY** by a former Motive Power Officer, until recently and for a number of years in active service. Address X Y Z, care Railway and Locomotive Engineering.

# THE UNION SWITCH & SIGNAL CO.

Consulting and Manufacturing  
Signal Engineers

Automatic Block Signals—Electric  
and Electro-Pneumatic

Interlocking—Electric, Electro-Pneumatic  
and Mechanical

Electric Train Staff Apparatus

GENERAL OFFICES AND WORKS AT  
SWISSVALE, PA.

### DISTRICT OFFICES:

New York: 143 Liberty Street  
Chicago: Monadnock Block  
St. Louis: Frisco Building

## Flexible Spout

Vertically in straight line. Also laterally. The latest improvement to

## Poage Water Columns

American Valve and Meter Company

CINCINNATI, OHIO

—SEND FOR CATALOGUE—

# The Best and Cheapest Books for Railroad Men

**AIR BRAKE CATECHISM** Price, \$2<sup>00</sup>

By Robert H. Blackall. 20th Edition. Contains 1500 Questions and their Answers on the Westinghouse Air Brake, which are strictly up-to-date. Includes two large Westinghouse Air Brake Educational Charts printed in colors. Gives the necessary information to enable a railroad man to pass a thoroughly satisfactory examination on the subject of Air Brakes. The author's many years' experience as Air Brake Inspector and Instructor enables him to know at once how to treat the subject in a plain, practical manner. Endorsed and used by Air Brake Instructors and Examiners on nearly every railroad in the United States. The standard and only complete work on the subject. 312 pages.

**LOCOMOTIVE BREAKDOWNS AND THEIR REMEDIES** Price, \$1<sup>50</sup>

By Geo. L. Fowler. Just issued. Tells how and what to do in case of an accident or breakdown on the road; includes special chapters on Compound Locomotives. Better procure a copy, as it contains 800 Questions and their Answers on Accidents and Breakdowns.

**LOCOMOTIVE CATECHISM** Price, \$2<sup>00</sup>

By Robert Grimshaw. 23d Edition. Is right up-to-date and contains twelve large Folding Plates and 1600 Questions and Answers on How to Run a Locomotive. The Standard Book on the subject, being written in plain language and free from mathematical formulae and complex problems.

**NEW YORK AIR BRAKE CATECHISM** Price, \$1<sup>00</sup>

By Robert H. Blackall. The only complete treatise on the New York Air Brake and Air Signaling Apparatus, giving a detailed description of all the parts, their operation, troubles, and the methods of locating and remedying the same. 250 pages.

**COMBUSTION OF COAL AND THE PREVENTION OF SMOKE** Price, \$1<sup>50</sup>

By Wm. M. Barr. Contains over 800 Questions and their Answers on the Science of Steam Making.

**AIR BRAKE CHARTS** Price, 50<sup>c</sup>

Showing the Westinghouse Equipment in ten colors, including freight and passenger engines. Every railroad man should possess these charts at this low price.

**A Special Circular** of any of these books sent on request. Any of these books sent pre paid on receipt of price.

**Agents Wanted at Every Terminal.** Write for our special terms. You can make equal to a month's pay selling our books on the side

**The Norman W. Henley Pub. Co.**  
132 Nassau Street, New York, U. S. A.

## Good Sander.

Our illustration represents the Fay & Egan Co.'s No. 4 improved Triple Drum Sander known as the "Conqueror." It is designed with a view of overcoming all undesirable features associated with machine sanded work, such as snake lines, furrows and waves. Faulty feed frequently causes veneered work to be sanded through, concaved or dubbed cornered. These defects are obviated in this machine by the oscillating movement of its three drums, laterally across the material.

The drums carry three grades of sandpaper, the third or last being the finest, which gives a finish to the work, after which it is dusted thoroughly by a rapidly revolving brush. When the sandpaper is worn out the drums can be easily recovered by any practical workman.

The feeding mechanism consists of eight powerful rolls, four above and

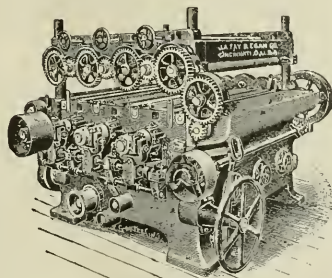

TRIPLE DRUM SANDER.

four below the platen. The frame carrying the upper feed rolls can be elevated automatically or by hand wheel to receive material up to 8 ins. in thickness. The rolls are driven by a train of heavy expansion gearing, thus insuring a steady feed. All levers and hand wheels are placed convenient to the operator. This machine practically finishes the work ready for the filling room or for varnishing.

Further detailed particulars concerning the Conqueror sander may be obtained by addressing the J. A. Fay & Egan Co., Cincinnati, O.

The Armstrong Bros. Tool Company, commonly called "The Tool Holder People," of Chicago, have just shipped two orders received recently from the Isthmian Canal Commission, aggregating almost One Thousand Armstrong Tool Holders, many heavy sizes being included. They have also recently received an order for Universal Ratchets for use in the Canal Zone. Many smaller shipments had preceded these later and larger orders.

# One Year and Eleven Months' SERVICE

WITHOUT REPACKING, ON

## HIGH-PRESSURE LOCOMOTIVES

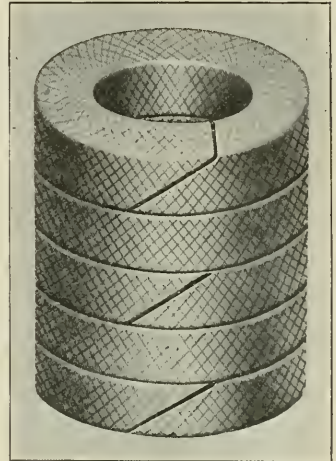

Style 300 TV.

A throttle failure is an absolute impossibility where Crandall's Throttle Valve packing is used.

IT WILL NOT BLOW OUT

## Crandall Packing Co.

FACTORY AND GENERAL OFFICE

**PALMYRA, - NEW YORK**

BRANCHES

New York  
136 Liberty St.

Cleveland  
9 So. Water St.

Chicago  
52 West Washington St.

# Patents.

GEO. P. WHITTLESEY

MCGILL BUILDING WASHINGTON, D. C.  
Terms Reasonable. Pamphlet Sent

## Molding Machines

Vertical Vibration. Power Draft

ALL KINDS OF MACHINES.

THE E. H. MUMFORD CO.  
17th & Calowhill Streets, PHILADELPHIA, PA.  
J. W. JACKMAN & CO., Ltd., 29 Victoria St. London, S. W.

# World's Fair

St. Louis

FIRST PRIZE FOR

# TOOL STEEL

AWARDED TO

McInnes Steel Co.

CORRY, PA.

in competition with the best makes in England and Germany. Also manufacturers of all kinds of Tool Steel, Die Blocks, and Steel Forgings.

Write for Prices and Information

STANDARD MECHANICAL BOOKS  
FOR ROAD AND SHOP MEN  
BY CHAS. McSHANE

The  
Locomotive Up to Date

Price, \$2.50

New York and  
Westinghouse Air Brakes

Price, \$1.50

One Thousand Pointers for  
Machinists and Engineers

Price, \$1.50

All books bound in fine cloth

AGENTS WANTED everywhere; write for terms and descriptive circulars. Will be sent prepaid to any address upon receipt of price.

GRIFFIN & WINTERS  
171 La Salle Street, CHICAGO

## Warped Castings.

One of the difficulties in machine construction is the warping of castings. This is particularly the case with castings that are partly planed or machined. This is caused by the fact that all castings on leaving the mould are in a state of stress arising from the tightening of the skin while cooling. After a portion of the surface is removed by planing, the exposed part of the casting will expand and assume a slightly rounded form, the stress from all of the other parts of the casting pulling in different directions causing the gradual rounding of the planed surface. When exactly straight surfaces are required the only remedy is to machine the castings all over, or if the pieces are flat, on opposite sides. It will sometimes happen that even after the surfaces are planed the warping continues, the stresses arising from the different thicknesses of the parts, and another planing may be necessary before a perfectly straight face can be secured. Stresses may be avoided by reheating castings to a cherry red and letting them cool off among lime.

## Portland Conduit System.

A substantial little pamphlet is issued by the H. W. Johns-Manville Co., of New York, illustrating their patented Portland sectional conduits which give perfect protection and efficient insulation for pipes conveying steam, gas, water or other liquids. Experience has shown that it is possible to convey either high or low pressure steam to any reasonable distance, and the Portland sectional conduit effects a saving in cost of installation and maintenance, besides increasing the efficiency. The conduit is vitrified and glazed both inside and out and allows no moisture to pass through. An asbesto-sponge conduit filling completes the insulation.

The John Davis Company, of Chicago, have lately issued two catalogues, either or both of which they will send to any one interested enough to apply to them. One of these catalogues deals with steam specialties, such as steam traps, safety water columns, back pressure valves, separators, blow off valves, reducing valves, regulating valves water and air regulators, boiler pump governors, stop and check valves, low water indicators, etc. The other catalogue deals exclusively with Eclipse separators. A receiver type of separator has been designed to provide large steam capacity at the engine, to steady the flow and prevent the pressure from dropping between boiler and engine, and in order to reduce vibration. Dry steam is not only a matter of fuel economy, but lessens the danger of acci-

This illustration shows the form of construction of the

## Dart Patent Union

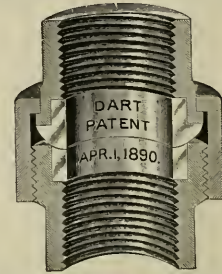

Every feature of construction represents the best points to insure stability and durability. The malleable iron pipe ends and nuts, in combination with bronze metal seats, are as near perfection as is possible to approach, and the sales to date indicate the public approval. There are none so good. For sale by all the principal jobbers in United States, Canada and Europe.

E. M. Dart Mfg. Co., Providence, R. I.

FAIRBANKS CO., SALES AGENTS.



## The Twentieth Century Master Mechanic

Won't use Solid Mandrels.  
Cost too much, take up too  
much room and don't give  
satisfaction.

## Nicholson Expanding Mandrels

Take everything from 1 to 7  
inch holes. Take up little  
room — always ready and  
you can buy four sets for  
the cost of one of the solid  
kind

## Are You Using Them?

Catalogue tells you  
more about them.

W. H. Nicholson & Co.  
Wilkesbarre, Pa.



# Locomotives, Freight and Passenger Cars

## New Flats, Box and Gondola Cars

of any capacity for immediate delivery. Locomotives of all weights and types

Shops at **Hammond, Indiana**  
**Dover, New Jersey**

Cable Address  
"FITZLUTH"

Export Shipments  
a Speciality

**FITZ-HUGH, LUTHER CO., Monadnock Block, CHICAGO**  
141 BROADWAY NEW YORK    CHEMICAL BLDG. ST. LOUIS    80 ST. FRANCIS XAVIER ST. MONTREAL, CAN.    RIALTO BLDG. SAN FRANCISCO

dent to the engine, and when the condensation from exhaust steam is returned to the boiler, the absence of oil, caused by its passage through the separator, is of very great importance. The catalogue shows a number of separators available for different conditions. Both these catalogues are designated by the letter S. Write direct to the Davis Company if you desire information on any of the specialties which are described in either publication.

### Traveling Engineers' Association.

The fourteenth annual meeting of the Traveling Engineers' Association was held in Chicago on August 29 to 31. Mr. A. L. Beardsley of the Santa Fe system is president. Papers were read and reports presented on various topics which come within the purview of the association. Among them were: The oil burning locomotive, devices used, methods of operation and difficulties met with; by Mr. J. B. Galivan. Care of locomotive boilers at terminals and while in service; by F. P. Roesch. Regularly assigned vs. pooled engines, merits of the systems; by the committee consisting of Messrs. C. F. Richardson, H. L. Bartels, F. B. Childs, W. J. Stuart and P. H. Stack. The Future Engineer; best methods for increasing his efficiency and raising his standard; by Messrs. D. L. Eubank, J. F. Emerson, J. M. Lynch, C. S. Murray and L. F. Bachman. Committee work on reports from the standpoint of its advantages to the association and the individual member, by Clinton B. Conger. Walschaerts valve gear by O. R. Rehmeyer. Tonnage rating by latest methods with the best rating in proportion expense of pull, wages and repairs to locomotives by F. W. Thomas. Handling of the Air Brake in passenger service to avoid breaks-in-two, discomfort of passengers, etc., by C. C. Farmer. Best

method of handling locomotives at terminals to reduce delays, by W. J. Hurley. Operation and maintenance of latest makes of lubricators for saturated and superheated steam, by F. Burke. The draughting of locomotives, by E. Hartenstein.

The McConway & Torley Company, of Pittsburgh, have sent to their numerous railroad friends a very useful little pamphlet which is the 1906 edition of the Car Interchange Manual, compiled and published by Mr. J. D. McAlpine, of the Lake Shore & Michigan Southern, at Cleveland, Ohio. The manual is a compendium of useful information for master car builders and car inspectors. It contains a brief abstract of every decision on the interchange rules given by the arbitration committee of the M. C. B. Association from November, 1888, to case 703, May, 1906. At the back of the little book there is a number of pages on which a variety of useful information is given, such as the values of new wooden cars. Table of synonyms of parts of cars known by various names. Table of words frequently misspelled on defect cards and car reports. Limits of tire wear for various types of steel tired wheels. Table of weights and measures, rules for calculating the power of levers and the size and weights of various commonly used articles, rules for first aid to the injured which includes dealing with elastic shock accidents. There is a table of what constitutes unfair usage within the meaning of the code of interchange rules and a classified index of the Arbitration Committee's decisions. In the front of the book there is a full and complete alphabetical index of the M. C. B. decisions on car interchange. The book is a useful one to those concerned in car repair or interchange. Apply to Mr. McAlpine if you want a copy.

### METAL PRESERVATIVE PAINTS AND PRIMER

for locomotives, boilers, stacks, front-ends, gearing, frame-work, metal roofs, etc.

Tell us your needs.

Metal preservative paints have been our specialty for 22 years.

Paints for all conditions.

THE STANDARD PAINT CO.

Sole Manufacturers  
100 William St., New York  
CHICAGO ST. LOUIS

### CONTENTS :

	PAGE.
*Bascule Bridges .....	399
Draw Gear, Friction Value of .....	402
*Tool, Old Rehabilitating .....	437
*Crank Axles .....	406
*Patent Office Department .....	413
Correspondence School, Our .....	419
Questions Answered .....	421
*Air Brake Department .....	423
*Train Order Cabinet .....	426
Steel vs. Iron .....	429
*Semi-Plug Valves .....	435
*Trucks, Boltless .....	439
*Sander, Fay & Egan Co. ....	441
Personals .....	431
Locomotives—	
*2-6-2 for the Great Northern .....	395
*B. & A. Suburban .....	427
*Caledonian, Six-Coupled .....	436
Cars—	
* Rapid Car Building in Indiana .....	412
*Steel Coach, for Southern .....	433
*Flat, Without Deck .....	417
*For Automobiles and Horses, B. & A. ....	428
Editorials—	
All Steel Passenger Cars .....	414
Block Signal Legislation .....	414
General Foreman, The .....	414
Railroad Economy .....	415
First Aid .....	415
Brakes, Power, on Cars .....	106
B. R. T. Troubles .....	409

TRADE MARK  
The T. O. Sargent Glove



"WRIST OR GAUNTLET"

TRY THEM

They are made for hard wear from the very best grade of chrome tanned horsehide leather. Heat and water proof. No rivets nor seams to hurt the hands.

If your dealer does not carry "Sargents" we will sell you direct on receipt of your size and \$1.00

Write for free leather match safe and descriptive booklet

DETROIT LEATHER SPECIALTY COMPANY, -- Detroit, Mich.

# TALMAGE SYSTEM

A MECHANICAL SYSTEM FOR LOCOMOTIVES  
THAT OVERCOMES THE BAD EFFECTS FROM  
THE USE OF UNDESIRABLE FEED WATERS

PATENTED IN UNITED STATES AND FOREIGN COUNTRIES

## RUBRA BOILER OIL TALMAGE BLOW OFF VALVES

USED IN CONNECTION

### GUARANTEE

WE GUARANTEE TEN TIMES GREATER MILEAGE BETWEEN  
BOILER WASHINGS AND TO REDUCE MOTIVE POWER EXPENSES SUFFICIENT TO MAKE THE COST OF OUR SYSTEM PERMISSIBLE.

THE TALMAGE MANUFACTURING COMPANY  
CLEVELAND, O., U. S. A.

J. O. TALMAGE, President

### INDEX TO ADVERTISEMENTS.

	PAGE.		PAGE.
Ace Machinery Co.	Front Cover	Dart, E. M. Mfg. Co.	443
Air Brake Chart	26	Davis, John Co.	23
Ajax Metal Co.	4th Cover	Detroit Leather Specialty Co.	444
Aldon Co.	—	Detroit Lubricator Co.	13
American Balance Valve Co.	4th Cover	Detroit Seamless Tube Co.	21
American Brake Shoe Co.	15	Dixon, Joseph, Crucible Co.	434
American Loco Sander Co.	437	Expanded Metal Co.	3
American Locomotive Co.	8	Falls Hollow Staybolt Co.	14
American Locomotive Equipment Co.	4th Cover	Fay & Egan Co., J. A.	11
American Valve and Meter Co.	440	Fitz Hugh Lather Co.	443
Baker, Wm. C., Heating and Supply Co.	5	Flanders, L. B., Machine Works.	11
Baldwin Locomotive Works.	10	Flannery Bolt Co.	439
Ball Webb, C. Co.	—	Franklin Mfg. Co.	2
Barnett, G. & H. Co.	2d Cover	Galema Signal Oil Co.	2
Barrett Machine Tool Co.	—	Garlock Packing Co.	18
Bettendorf Axle Co.	—	General Electric Co.	19
Big Four Railroad.	9	Gold Car Heating Co.	436
BOOKS:—		Goodrich Rubber Co.	18
Air Brake Chart	26	Gould Coupler Co.	18
Compound Locomotives	9	Grand Truck Ry.	16
Computers	25	Greene, Tweed & Co.	2d Cover
Conger's Air Brake Catechism.	—	Griffin & Winters.	442
Firing Locomotives	9	Hammitt, H. G.	4th Cover
Locomotive Running and Management	9	Hancock Inspirator Co.	—
Machine Shop Arithmetic.	—	Hendrick Mfg. Co.	18
Miscellaneous.	20	Henley & Co.	441
Oil Burning in Locomotives	18	Hicks, F. M., & Co.	14
Train Rules and Train Dispatching.	8	Hoffman, Geo. W.	18
Twentieth Century Locomotive.	8	Homestead Valve Mfg. Co.	437
Bordo, L. J., Co.	438	Hunt, Robert W., & Co.	437
Boston & Albany R. R.	16	Illinois Central R. R.	26
Boston & Maine R. R.	9	International Correspondence Schools.	9
Carpenter, The J. M., Tap & Die Co.	17	Jenkins Bros.	4th Cover
Central R. R. of New Jersey	7-9	Johns-Manville, H. W., Co.	435
Chalante Hotel.	1	Kennicott Water Softener Co.	—
Chapman Jack Co.	7	King-Lawson Car Co.	3d Cover
Charts:—		Kinnear Mfg. Co.	2d Cover
Combination Passenger & Sleeping Car.	13	Lackawanna R. R.	16
Locomotive, Atlantic Type.	7	Lake Shore.	17
Locomotive, American Type.	9	Latrebe Shoe Co.	—
Chicago Car Heating Co.	13	Latrebe Steel & Coupler Co.	8
Chicago Pneumatic Tool Co.	16	Lexington Hotel.	7
Chicago & Alton R. R.	18	Locomotive Charts:	
Cleveland City Forge & Iron Co.	4th Cover	Atlantic Type.	7
Cleveland Twist Drill Co.	4th Cover	Locomotive Publishing Co., Ltd.	16
Climax Bearing Co.	8	Long & Allstater Co.	17
Commercial Acetylene Co.	24	Magnus Metal Co.	—
Commonwealth Steel Co.	3	Manning, Maxwell & Moore.	22
Consolidated Railway, Electric Lighting & Equipment Co.	3	McConway & Torley Co.	2d Cover
Crandall Packing Co.	443	McCord & Co.	—
Damasuc Bronze Co.	23	McInnes Steel Co.	442
		Morse Twist Drill Co.	—
		Mumford, The E. H., Co.	441
		Munn & Co.	—
		Nathan Mfg. Co.	14
		National Acme Mfg. Co.	3
		Nation Malleable Castings Co.	4th Cover
		New Jersey Asbestos Co.	15
		New York Central R. R.	19
		Nicholson, W. H., & Co.	443
		Niles-Bement-Pond Co.	3
		Norton Grinding Co.	1
		Norwalk Iron Works.	14
		Pacific Trading Co.	13
		Pennsylvania R. R.	—
		Pittsburgh Spring & Steel Co.	2
		Porter, H. K., & Co.	17
		Pratt & Whitney.	3
		Pressed Steel Car Co.	10
		Railway Materials Co.	2d Cover
		Railway Steel Spring Co.	10
		Ralston Car Co.	4
		Revere Rubber Co.	3d Cover
		Rogers, H. A., Co.	2
		Rogers Locomotive Works.	17
		Ross Valve Co.	4th Cover
		Rue Mfg. Co.	18
		Safety Car Heating & Lighting Co.	11
		Sight Feed Oil Pump Co.	—
		Saunders, D., Sons.	14
		Scandinavia Belting.	15
		Sellers, Wm., & Co., Inc.	2
		Slight Feed Oil Pump Co.	—
		Skat Mfg. Co.	440
		Slocumb, F. F., & Co.	440
		Smooth-On Mfg. Co.	9
		Southern Pacific R. R.	16
		Standard Car Truck Co.	2d Cover
		Standard Coupler Co.	15
		Standard Paint Co.	443
		Standard Steel Works.	10
		Star Louis Car Co.	21
		Star Brass Mfg. Co.	13
		Starratt Co., L. S.	19
		Storrs Mica Co.	442
		Syrington, T. H., & Co.	7
		Tabor Mfg. Co.	4
		Talmage Mfg. Co.	444
		Underwood, H. B., & Co.	11
		Union Pacific R. R.	7
		Union Switch & Signal Co.	440
		United States Metallic Packing Co.	23
		Utica Steam Gauge Co.	25
		Vacuum Cleaner Co.	13
		Van Duzen Co.	25
		Vulcan Iron Works.	10
		Walworth Mfg. Co.	2d Cover
		Wasburn Co.	4th Cover
		Watson-Stillman Co.	4th Cover
		Westinghouse Air-Brake Co.	6
		Westinghouse Electric & Mfg. Co.	7
		Willing Foundry Equipment Co.	23
		Willetts, Geo. P.	441
		Williams Typewriter Co.	14
		Wood, R. D., & Co.	7
		Zephon Chemical Compound Co.	15

# Railway and Locomotive Engineering

Copyright by Angus Sinclair Co.—1906

A Practical Journal of Railway Motive Power and Rolling Stock

Vol. XIX.

136 Liberty Street, New York, October, 1906

No. 10

## Railway Steamship.

When looking at a beautifully proportioned steamship like the one we present this month, the ordinary railroad man probably thinks of some appropriate nautical terms, such as he might hear if on board. Two very

meaning the side which was usually put against the wharf in order to lade or load the ship. It was, in fact, the side always put nearest the port as distinguished from that toward the open sea. This word was years ago officially changed to port, in order

why the larboard side, unencumbered with the fixed oar was brought up to the wharf. Starboard comes from the Anglo-Saxon word, *steor*, a rudder, and *bord*, side. The starboard side was the rudder side and the port side was the one over which the loading



"SHE WALKS THE WATERS LIKE A THING OF LIFE, AND SEEMS TO DARE THE ELEMENTS TO STRIFE."—Byron.

interesting words used in connection with steering come to mind, the origin of which is interesting. These words are Port and Starboard. In former days the port or left hand side of the vessel when one looks toward the bow, was called the larboard side, and the word is said to be derived from the Anglo-Saxon, *leer*, empty, but later from the Middle English "laddehord,"

to prevent confusion with the word of similar sound, starboard, used to designate the right side of the ship. The word, port, was, therefore, an appropriate change from larboard.

The word, starboard, comes from the days when the bow and stern were of similar shape and the ancient galleon was steered by an oar at the stern, fastened in place over the right side, and this is

and unloading was done. Modern ship construction has changed the method of steering and of loading, but the words remain.

We have been able to secure some interesting facts concerning this steel steamship, which forms part of the Pacific Coast Fleet of the Canadian Pacific Railway. Mr. A. L. Brownlee, chief engineer of the vessel, has kindly

contributed the information. He says: In 1902 the C. P. R. let a contract to Messrs. C. S. Swan & Hunter, of Newcastle on Tyne for the steamship "Princess Victoria." The ship was commenced in the summer, was launched in December, had her trial trip on January 27, sailed from Eng-

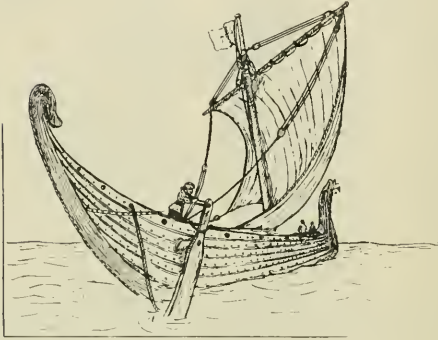

ANCIENT SHIP SHOWING THE "STEOR-BORD."

land on January 30, arriving at Victoria on March 28, 1903, having made the trip in 58 days, with two boilers only, her average consumption on the trip was 20 tons per day, giving an average speed of 12 knots.

The vessel is 300 ft. between perpendiculars, 40 ft. 6 ins. beam, 17 ft. 6 ins. depth of hold. Her cross section shows a flat floor, and full bilges with bilge keels, while the ends are very fine and cut away on the keel, both foreward and aft. Her stern is of unusual construction, the idea being to obtain the maximum speed and handling power. It is doubtful if any vessel on the Pacific Coast is so well subdivided with water-tight compartments, with double bottom, numerous transverse bulkheads and water tight flats. The vessel has been so designed that it would be almost impossible to sink her, even though the vessel may be loaded and two compartments punctured. Her boilers being in two separate water tight compartments give assurance that the entire steam generating system would not be put out of action by an accident.

There are two sets of four cylinder triple expansion engines, balanced on the Yarrow, Schlick, Tweedy system, the diameters of the cylinders being 26 ins., 40 ins., 43½ ins. and a stroke of 33 ins. The revolutions at full speed are 170. Each cylinder with its casing is a separate casting, but they are fastened to each other fore and aft and athwart ships by long staybolts to lessen the vibration. The pistons are made of cast steel I. P. and Intermediate Pressure fitted with Ramsbottom rings, and L. P. fitted with deep rings and springs. The piston rods are made of forged

steel, with metallic packings in all glands; the piston valves are fitted on the H. P. and I. P. and double ported slide valves on the L. P.

The cylinders are mounted on cast steel columns inboard, and turned steel columns outboard. The working platform is amidships, and Brown's gear is fitted on both reversing engines and so arranged that one engineer can work both engines if necessary. Bed plates are of cast iron, with main bearing bushes brass lined with white metal and having cast steel caps. The connecting rods are forked and the brasses lined with white metal. The crank shafts are of forged ingot steel, made in two pieces. The cranks are arranged at angles, usual in this system of balancing. Thrust bearings of the usual horseshoe type are used, lined with white metal and with a cold water service arranged through each shoe. The screw propellers are three bladed, of Manganese bronze, hubs of cast steel, diameter 11 ft. 6 ins., pitch 14 ft. 6 ins., with a 41½ sq. ft. surface.

same levers are the Aspinwall governors, which are undoubtedly very efficient marine governors.

All pumps are neatly arranged on the forward engine room bulkhead, and these consist of port and starboard centrifugal circulating pumps, both cross connected and so arranged that either pump can work to either or both condensers if required or from the bilge. There is one auxiliary duplex pump 10x6½x10, also one service pump of the same size; these pumps are cross connected and can be made available for either service. A pair of Weir's feed pumps, either of them of sufficient size to feed all the boilers at full power are used, and this when the engines are running at 12 strokes per minute with feed water at 212 degrees Fahrenheit. A water ballast pump of duplex type and 125 tons per hour capacity is used to supply the necessary fluid ballast, and is a centrifugal pump placed on the starboard side. On the top platform there is the steering engines and a feed heater, and below this on the next platform there is a feed filter. There are two Canadian General Electric dynamos placed fore and aft between the thrust-blocks. The capacity of the dynamos is 15 KW. each.

Steam is supplied by six Scotch single ended boilers arranged in pairs,



BREAKERS ON A ROCK BOUND COAST.

The surface condensers, which are in the wings, are circular and made of steel plate, with brass tubes and tube plates. Air pumps of the Edward's type are worked by levers from the foreward L. P. crossheads. Engine bilge and sanitary pumps are worked by the same levers. Attached to the

each pair of boilers has its own smoke-stack, and arranged to run as a single unit if required. The mean diameter of the boilers is 14 ft. 9 ins., mean length 11 ft., with three Morrison furnaces 7 ft. 10 ins. long on each boiler, 3 ft. 10 ins., inside diameter, steam pressure 160 lbs. per sq. in. and tested by

hydrostatic pressure to 320 lbs. There is 2,279 ft. of heating surface in each boiler. This gives a total heating surface of 13,674 sq. ft. in the six boilers. Forced draught on the closed stoke-

#### Case-Hardening Wrought Iron.

This is a paper read at the recent annual convention of the National Railroad Master Blacksmiths' Association by Mr. George F. Hinkens, foreman

case-hardening is to obtain an external steel encasement with a core of fibrous iron in the center. This effect is produced by heating in a perfectly air tight box with an animal carbonizing ingredient. The box should be of plate or cast iron from  $\frac{1}{2}$  to 1 in. thick, the size and thickness of box depending on articles to be operated upon. The articles are put in the box in alternate layers with the carbonizing ingredients, commencing at the bottom of the box say with a layer of granulated bone of the thickness of 1 in., upon this a layer of the articles is placed, then another of bone about  $\frac{3}{4}$  in. in thickness, and so on until the box is nearly full, finishing with a layer of bone on top of the articles, which should be 1 in. deep, so as to well protect the first or top layer of articles and prevent blistering.

"The packing completed, the lid is put on and hermetically sealed or luted with loam or fire clay. The box, or boxes, are now placed in a suitable furnace. The furnace should give a uniform heat of 1,350 to 1,550 degrees Fahrenheit as recorded by the Morse Heat Gauge. Overheating is injurious and will crystalize the iron and make the articles brittle. In treating wrought iron for case hardening there are several considerations, the principal one being heat, and duration of time for carbonization, same being governed by the size or



PACIFIC COAST SCENERY—THE GAP—C. P. RY.

hold system is furnished; there being four large air fans installed, but in practice its use has been found unnecessary, the boilers supplying all required steam under natural draught. There is a sea-ash ejector in each stokehold. All main auxiliary steam pipes are of copper. The boilers and machinery were manufactured and installed by R. and W. Hawthorne, Leslie and Co., Ltd., Newcastle on Tyne.

The "Princess Victoria" makes good time on her regular round trip from Vancouver to Victoria, on down to Seattle, and back via Victoria to Vancouver in the twenty-four hours, six days a week. She fairly earns her right to rank as a railroad ship.

Looking at this fast modern steamer, this thing of steel and steam, one cannot help contrasting her with the ancient Queen of Egypt's barge and while contrasting, half applying Shakespeare's words: "But who is this, what thing of sea or land—female of sex it seems—that so bedeck'd, ornate, and gay, comes this way sailing like a stately ship of Tarsus, bound for th' isles of Javan or Gadire, with all her bravery on, and tackle trim."

In our September issue we showed, as our frontispiece picture, the double roller lift bridge on the Chicago Terminal Transfer Railroad. We described the roller lift bridge over Newark Bay on the Central Railroad of New Jersey. A line of type omitted in one of the opening paragraphs failed to make this quite clear.

blacksmith of the Westinghouse Air Brake Co., at Wilmerding, Pa.

"Wrought iron is nearly pure decarbonized iron and is not possessed of the property of hardening. Articles



PACIFIC COAST SCENERY—STEAMER ON ARROW LAKE.

made from wrought iron may be externally converted into steel without depriving the interior of its natural character or structure. The process is called 'Case Hardening.' The object of

bulk of the work to be case-hardened. In point of importance heating stands first, for if the primary cause of bad case-hardening could be traced, its origin in a majority of cases would be

found in bad heating. There is no operation connected with case-hardening which requires more watchfulness and gives more anxiety than proper heating.

"It may therefore repay us to examine with care the conditions to be observed in obtaining results: As to heat, we must have a thorough admission, uniform and exacting to a degree. The heat must be constant and uniform and should not exceed 1,350 degrees Fahrenheit, for the degrees of heat will have a bearing on the fibrous structure of the material. A high and excessive heat will render the material brittle and if the article is light in structure it is apt to break easily in service; therefore it behooves us not to overheat or unevenly heat articles to be case hardened. Consequently keep the furnace at a regular or constant temperature, for if the articles to be case-hardened are overheated, damage is done in so far as a fibrous structure is concerned, the article becomes hard, but the interior is brittle

the natural and proper structure of the material. Well, he got a very deep case or shell and very hard, but the articles were more akin to pig, than to wrought iron, due to excessive heat. They case-hardened crank pins in this manner. The crank pins were of the solid-rod type with a projecting threaded end. Their method of putting the crank in the driving wheels was by placing a sleeve over the threaded end of the pin, this sleeve butted against the shoulder of the crank pin. A battering ram was then brought into service, striking the sleeve. Of course this method produced a great shock at the weak point of the pin, which was at the small or nut end. Oftentimes the end in question would drop off while driving in the pin. Upon examination I found the structure of the material as friable and brash as cast iron. The amazing part of it was that the general foreman blamed the material. Of course the material was bad, but not until this particular genius put the finishing

thus described can be heated with either oil or gas and has a capacity of eight boxes 12 ins. wide, 20 ins. long and 8 ins. high. The size of the box as a matter of course is governed by the size of the articles to be case-hardened.

"A quick method for case-hardening consists in heating the material to be hardened up to a red heat and then submerging it in a bath of molten cyanide of potash, leaving it in from one to five hours, according to the bulk of material to be hardened. Cyanide of potash gives off poisonous fumes, consequently the vessel containing it should be placed in a furnace with a draft. This method is dangerous for the operators and should, if used at all, be used in a very careful manner."

#### Northern Pacific 4-6-2, Passenger

The American Locomotive Company have recently supplied the Northern Pacific Railroad with a considerable amount of power and among the en-

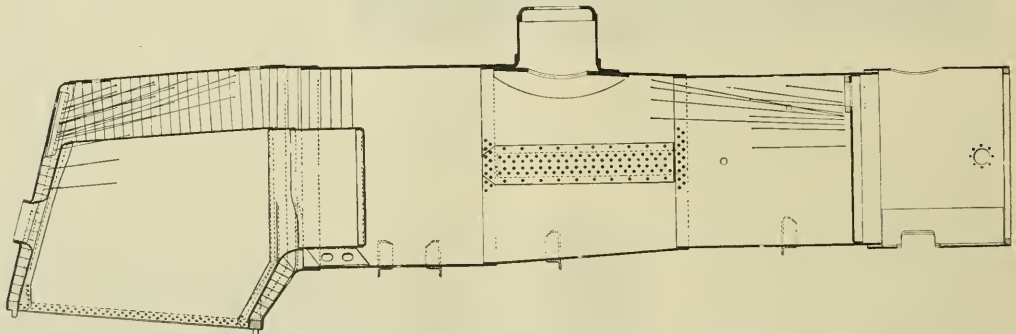

SECTION OF BOILER FOR NORTHERN PACIFIC 4-6-2 SHOWING COMBUSTION CHAMBER.

and crystalline when it should be fibrous and showing the dark or black appearance of its natural structure with a fine grained surface analogous to tool steel. Where I am employed we do a great deal of case-hardening, all of which is done under my supervision and direction. We case-harden as much as five tons of material in 24 hours. This requires ten furnaces. We are exceedingly particular about the treatment, as much so as in the treatment of tool steel when tempering.

"Some years ago I was employed where the general foreman had charge of case-hardening. Of course a general foreman has and should have that right or privilege. However, this particular individual thought he was the 'Only' in that particular branch. Case-hardening was his 'long suit.' He arrived at his conclusion from the great depth of case or shell of hardness he could produce and the quickness of time in which he accomplished the result, never taking into account the preservation of

touch on it by his peculiar and wrong method of case-hardening.

"The furnace is an important factor. An oil or gas furnace, to work successfully should be so constructed as to secure the proper mixture of gases, a thorough and even combustion in every part of the furnace. The furnace should be constructed with the roof arched throughout its entire length in order that the heat may be reflected directly and uniformly upon the boxes. The passage to the chimney is formed underneath the hearth, causing a downdraft. The action is to throw the heat down upon the boxes. There are six flues separated from each other at the end farthest from the fire place. These flues run parallel towards the fire place or combustion chamber where they are connected downward with the main flue under ground, thence into the chimney. It will be seen that this arrangement of furnace insures, as nearly as possible, an even heat throughout every cu. in. of the furnace interior. The furnace

gines are twenty 4-6-2 simple passenger machines built at the Schenectady shops. The cylinders are 22x26 ins., and the driving wheels are 69 ins. outside tires. The calculated tractive effort, with 200 lbs. boiler pressure, is 31,000 lbs., and with 147,500 lbs. on the drivers, as is the case with the last and heaviest engine of the series, the factor of adhesion becomes 4.76.

The valves are piston type and are driven by Stephenson link motion direct connected with transmission bar, which passes over the forward driving axle. The valve travel is 6 ins., they have 1 in. steam lap and an exhaust clearance of  $\frac{1}{8}$  of an in. The valves are set line and line forward, and  $\frac{3}{2}$  of an in. blind on the back motion. They have  $\frac{3}{4}$ -in. lead at a cut-off of  $6\frac{1}{2}$  ins. The valves are 12 ins. in diameter. The links are each made solid and have a radius of 48 ins.

All the wheels are flanged, spaced 72 ins. apart. The rods are all of I-section, the connecting rod having a fork

at the big end. The guide bars are flush with the crosshead at the upper edge, and the crosshead is of the alligator type.

The rigid wheel base is 12 ft. long. The wheel base of the engine itself is 32 ft. 6 ins. and that of the engine and tender together is 61 ft. 11 ins. The weights are as follows: Engine 223,500 lbs.; engine and tender 368,300 lbs.

The engines are identical in design with the Class Q-1 on the N. P., except in the design of the boilers. The boilers of both classes are of the radial-stayed, extended wagon-top type with the same size fire box and the same outside diameter at the front and back and the same length over all. The style of boiler shown in our line cut has 2 in. tubes spaced  $2\frac{3}{8}$  ins. centers, at the front end. The boilers of the engines illustrated are designed with

	With comb. chamb. (Illustrated.)	Without comb. chamb. (Class Q-1.)
Tube heat'g	2,737 square feet	3,339 square feet
Fire box....	233 square feet	182 square feet
Arch Tubes.	9 square feet	7 square feet
Total surf..	2,979 square feet	3,528 square feet

From this comparison it will be seen that the tube heating surface has been reduced 602 sq. ft., or 18 per cent., by the use of the combustion chamber, and the total heating surface has been reduced by 550 sq. ft., or about 15.6 per cent., while the fire box heating surface has been increased 51 sq. ft., or about 28 per cent.

It is interesting, also, to compare the ratios of tube heating surface and total heating surface to the volume of one cylinder in the two classes of engines, both having the same size cylinders. Total heating surface divided by volume of one cylinder in the engines with combustion chamber, is 520 and

a good opportunity for judging of the comparative merits of the two designs of boiler and the record of these engines with combustion chambers as compared with those of the same design running on the same road and under the same conditions but with boilers without combustion chambers will be of interest to all concerned.

The twentieth engine of this lot, as we have intimated, is equipped with the latest design of the Schenectady superheater.

The combustion chamber and superheater are among the most recent developments in locomotive design and the Northern Pacific officials and the whole railroad world will have an opportunity to watch the performance of the three different exponents of recent locomotive construction — the simple engine with long flues, the simple engine with short flues and combustion



PASSENGER 4-6-2 FOR THE NORTHERN PACIFIC.

D. Van Alstyne, Mechanical Superintendent.

American Locomotive Company, Builders

a combustion chamber 3 ft. long and the tubes are 16 ft. 9 ins. long. The combustion chamber cuts off 1 ft. 9 ins. from the length of the tubes. In addition to being shorter, the number of tubes in this boiler is less than in the boiler of the Class Q-1, which were built some years ago. There are 306 tubes in the first nineteen engines built in this lot and 192, with superheater in the one we show.

Comparing the Class Q-1 engines with these engines shows that the older engines had 347 tubes and the tube heating surface and total heating surface are, accordingly, much less in the engines illustrated than in those without the combustion chamber, while the fire box heating surface is much greater. The comparative heating surfaces are as follows:

without combustion chamber is 616. These ratios are lower in the engine with the combustion chamber and higher in the engine without than are generally found in the Pacific type locomotive, the average ratio of total heating surface to cylinder volume is 550. The combustion chamber in the 4-6-2 type is supported by expansion stays, radial stays, staybolts and bottom braces. The water space at the bottom is  $7\frac{1}{2}$  ins., and 7 ins. at the side, giving good water circulation with no danger of the combustion chamber being overheated. Though the tube heating surface is reduced by the presence of the combustion chamber, the fire box heating surface is greatly increased, and this increase in the fire box heating surface seems to more than offset the loss of the tube heating surface.

These two groups of engines afford

chamber, and the simple engine with combustion chamber and superheater, all three engines being identical in design except for the special features of combustion chamber and superheater

Some of the principal dimensions are appended for reference:

Weight—In working order, engine and tender, 368,300 lbs.

Heating Surface—Tubes, Nos. 1-19, 2,736.7 sq. ft.; fire box, 232.8 sq. ft.; arch tubes, 8.9 sq. ft.; total, 3,076.4 sq. ft. Tubes, No. 20, 2,196.37 sq. ft.; fire box, 233.41 sq. ft.; arch tubes, 8.9 sq. ft.; total, 2,438.66 sq. ft.

Superheating Surface—341.15 sq. ft.  
Grate Area—All engines, 43.5 sq. ft.

Axes—Driving journals, main,  $9\frac{1}{2} \times 12$  ins.; others,  $9 \times 12$  ins.; engine truck journals, diameter, 6 ins.; length, 11 ins.; trailing truck journals, diameter, 8 ins.; length, 14 ins.; tender truck journals, diameter,  $5\frac{1}{2}$  ins.; length, 10 ins.

Boiler—First ring,  $7\frac{3}{8}$  ins.; fuel, bituminous coal.

Fire Box—Type, wide; length, 96 ins.; width,

65½ ins.; thickness of crown, ¾ in.; tube, ¾ in.; sides, ¾ in.; back, ¾ in.; water space, front, 4½ ins.; sides, 4 ins.; back, 4 ins.

Crown s aying—Radial.

Tubes—Seamless steel: Nos. 1-19, Engine 306, 2 ins. diameter; No. 20, Engine 192, 2 ins. diameter; No. 20, Engine 24, 5 ins. diameter for superheater; length, 16 ft. 9 ins.; gauge, No. 11 B. W. G. except for 5 ins. tubes, which are 3/16 in. thick.

Air Pump—9½ ins. right side; 1 reservoir, 22½x 136 ins.

Engine Truck—Four wheel swing center; trailing, radial type with outside journals.

Piston—Rod diameter, 4 ins.; piston packing, C. I. snap rings.

Tender Frame—13 in. steel channels.

Tank—Style, water bottom; capacity, 7,000 U. S. gallons; fuel, 12 tons.

Wheels—Engine truck, diameter, 33 ½ ins.; trailing truck, diameter, 45 ins.; tender truck, diameter, 33½ ins.

### Shifting Winds and Cooler.

Energy may be changed from one form to another, but none of it can be destroyed. This is one of the fundamental laws of nature and an exceedingly good manifestation of its operation may be found in the conditions which prevailed in the New York Subway this summer. Coal burned at the

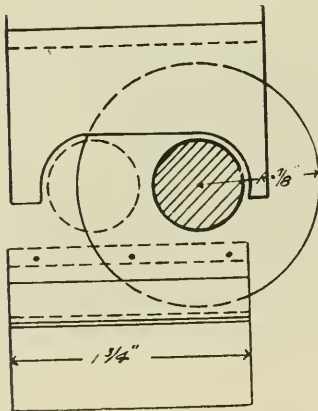

PIVOT WHEEL IN LOUVER BRACKET.

central power station gives off heat. This is used to generate the steam which drives the engines in the power house. The engines transform part of the energy they receive into an electric current, which being conducted to the third rail and thence to the car motors, moves the subway trains, and in the moving of these trains heat is given off. There are losses at each transformation of energy, but even allowing for these, the temperature of the air in and about the moving trains is considerably raised and the effect becomes plainly noticeable when it is confined as it is in the subway. A very thorough system of tunnel ventilation has lately been installed under the supervision of the Rapid Transit Railroad Commission of New York.

The heat liberated in the work of propelling these underground trains may be realized by anyone who reflects that in order to stop a moving train, the whole amount of energy represented by its motion must be dissipated in the form of heat before it can be brought to rest, and the sparks which fly off from the heated brake shoes and the rapid wearing away of the shoes themselves, are but small evidences of the total transformation of energy which is constantly taking place, and of which the warm air in the subway is an easily recognized and tangible proof.

Mr. George S. Rice, chief engineer of the Rapid Transit Commission, has furnished some interesting statistics on this subject.

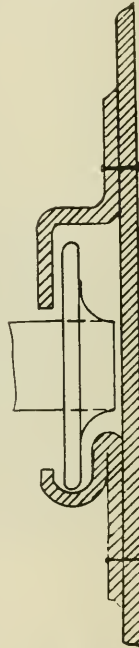

WHEEL IN GROOVE.

changes in traffic conditions throughout the day and from month to month. There is a certain quantity of heat given off by the passengers. This probably amounts to less than 2 per cent. of that liberated by the rolling stock."

The ventilation of the Brooklyn Bridge Station is secured, not by the direct exhaust of air from the tunnel, but by drawing air from the outside, and distributing it over the platforms. There are four fans, similar to those used elsewhere along the line, and these are so arranged that the air they draw from the street comes in through gratings and enters large galvanized iron conduits. The two conduits car-

ried overhead, lead to chambers situated close to the fans, each on opposite sides of the station. In each of the chambers, which are made of galvanized iron, there is about 4½ miles of 1-in. iron pipe arranged very much like a huge radiator. Through these pipes water at a temperature of about 59 de-

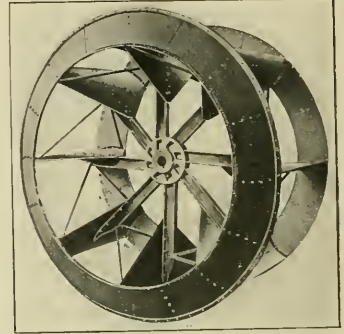

CONSTRUCTION OF THE FAN.

grees Fahrenheit, is pumped. The incoming air is passed under, over and around these pipes in what forms the cooler. The pipes have all together a total heat absorbing surface of about 15,550 sq. ft. When in contact with the pipes, the air parts with a great deal of its heat and this raises the temperature of the water, and the warmed water is discharged into the subway drains. The cooled air passes again

Both of these factors are subject to large variations, due to the changes in traffic conditions throughout the day and from month to month. There is a certain quantity of heat given off by the passengers. This probably amounts to less than 2 per cent. of that liberated by the rolling stock."

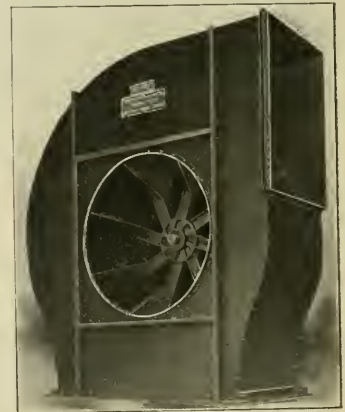

SUBWAY VENTILATING FAN.

into conduits which run along the station ceiling, over the passenger platforms, from which it is discharged through a series of openings. The water for the coolers is drawn from four artesian wells, and forced through the piping, by electrically driven pumps. The wells have been sunk to a depth of



about 45 ft. and have no direct connection with the water in the East river. The subway is approximately 50 ft. wide by 13 ft. high and from the Brooklyn Bridge Station to 96th street, a dis-



BACK OF TRINITY BUILDING.  
(From Office of Ry. and Loco. Engineering.)

tance of 6.43 miles, there is in it about 26,800,000 cu. ft. of air. This volume of air must be driven out and an equal amount drawn in, within a reasonable time in order to carry off the heat which is constantly being liberated while trains run and people travel.

Along the line and between the Brooklyn Bridge Station and that at Columbus Circle (59th street), a distance of a little over 4½ miles, there are fourteen ventilating chambers recessed in the tunnel sides. These are placed so that there is one between each two stations, and as far as practicable, any two adjacent chambers are on opposite sides. In these chambers there are, in all, twenty-five electrically driven fans, made by the American Blower Company, of Detroit. These fans discharge air from the tunnel directly to the street. In each ventilating chamber in addition to the fans there are a number of louvers or automatic dampers, which have a capacity for discharging air through the action of train movement, about equivalent to the capacity of the fans, and these louvers are so arranged that the air can only flow outward.

The louver-slats are simple, cleverly designed, flap doors weighted so that they always remain closed, and in an almost vertical position when not acted on by air pressure from within the tunnel. They are mounted each on a shaft which terminates in two wheels 1¾ ins. in diameter. These little wheels run in shallow grooves formed in small metal brackets bolted to the frames. The louver-slat, therefore, in opening, moves horizontally forward a distance of about ¾ of an inch, securing the maximum opening without the louver-slat having to become perfectly horizontal. The slat does not require to be oiled, and the constant flow of air outward keeps the grooves free from dust and grit, and friction is thus very economically reduced to a minimum.

In the 4½ mile section of road between the Brooklyn Bridge and 59th street, the volume of air is approximately 19,000,000 cu. ft., and the fans,

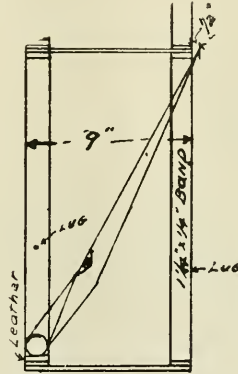

CROSS SECTION OF LOUVER.

when in operation discharge 1,120,000 cu. ft. of air per minute from the tunnel. Above 59th street, and up to 96th street, a distance of nearly 2 miles, there are louver openings, at present without fans, and through these openings air is discharged by what we may call the piston-like action of the moving trains. There will eventually be exhaust fans placed in artistic little buildings on the street level, and over the mid-position opening, between stations.

Air is removed from the subway by exhaust fans, and is blown out through passages connected with the fans. The outflow is therefore positive. Air is also removed by the piston-like action of moving trains. The train action forces air out through louvers which are provided with slats which close against inflow. Air is therefore compelled to enter the subway at the station stairways and through additional openings provided at stations and covered by gratings on the sidewalk level.

These gratings have each alternate bar covered with carborundum, and this prevents any chance of slipping by those who walk over them. The fans act independently of the louvers. They have their own intake through the walls of the tunnel, so that the exhaust by the fans does not pass through the louvers. The idea is that during maximum train movement, the louvers will do the work, but when the train movement is low, the fans are run to make up the loss, or at times all are worked together. An important point about the fans is that in case of stoppage of trains by accident the fans can then be made to do the work, and quickly rid the tunnel of smoke in case of fire.

The total area of the stairway openings from the Bridge Station to 96th street amounts to 4,800 sq. ft. and the gratings add an effective 2,500 sq. ft., making a total of 7,300 sq. ft. for the inlet of air. This is somewhat less than the area of the square contained between the boundary lines of the regulations "diamond" on a baseball field. The openings for the discharge of air make an aggregate of 5,750 sq. ft.



EMPIRE BUILDING, 73 BROADWAY.  
(Souvenir Post Card Co.)

The rate of air discharged when the fans are all working is about 1,120,000 cubic feet per minute, and as there is 19,000,000 cu. ft. of air in the subway between the Bridge and 59th street, the air in that portion of the tunnel can be renewed in 17 minutes and the

7,800,000 cu. ft. between 59th street and 96th street, can be driven out by the piston-like action of the trains, in about 25 minutes.

To gain some idea of what these volumes of air would be like, if piled up in masses above ground, we may refer to two well known sky-scrapers, situated on what has been aptly called the "canyon of lower Broadway" in New York. The Trinity building stands approximately 290 ft. above street level, it is about 262 ft. deep and has an average width of 45 ft. The cubic contents of this building is therefore 3,419,100 cu. ft. Its near neighbor, the Empire building, rises to a height of about 300 ft. above the street.

Empire building and the piston-like action of the trains running on maximum schedule is capable of effecting a discharge of air equal to these two, in about 25 minutes. The total amount of air in the 6.43 miles of subway, if piled up in building blocks, would equal the combined volumes of four Trinity buildings and three Empires. When the ventilating process, designed to give New Yorkers cool and pure air, as they travel in the Broadway "tube," is in vigorous action, the work of the fans and the air push of the trains, would be capable of blowing away these seven atmospheric sky-scrapers in less than half an hour.

#### Lubricator Guard.

The mechanical department of the Missouri Pacific, of which Mr. W. O'Herin is the head, has provided a number of engines with a lubricator guard, which is intended to protect the engineer and fireman in case one or more of the glasses break, and the device is serviceable and it does not take up much room and is not in the way.

The whole thing consists of a set of small brass frames, four in number, each of which holds a piece of glass,  $\frac{1}{4}$  in. thick and  $4\frac{3}{4} \times 1\frac{3}{4}$  in. face, as shown in Fig. 1. These guard glasses are placed in front of the lubricator, and so to speak, wrapped round it, so that no space is lost. The glass itself is  $\frac{1}{4} \times 2\frac{1}{4} \times 4\frac{1}{2}$  ins. and is held in the frame by a hardened steel spring made of  $\frac{1}{8} \times \frac{1}{4} \times \frac{3}{8}$  in. steel. This is bent down in the center, and the ends are held down under lips cast in the top of the slot for holding the glass.

Looking at it in plan, there is a supporting frame with two arms which is screwed on a stud in the bottom of the lubricator, and at the end of each arm, A and B, Fig. 2, a small upright stem is fastened. On each upright stem, the little frames containing the protecting glasses are hinged, and a coil spring holds each in place.

The four frames practically surround the lubricator and stand to one another at the same angle that the faces of a hexagon nut do. In front of all where the two middle frames meet, a split pin dropped in through two lugs prevents these little glass gates from opening under the force of steam or water from a broken lubricator. The two outside glass gates are also conveniently secured.

The object of the coil springs on the upright stems is to hold the frames down at all times, and yet to permit of a certain amount of adjustment being made so as to suit the requirements of the case where the lubricator guard is used. The springs hold the frames down and they are supported each by

a strut made out of  $\frac{1}{8}$  in. round spring steel, the lower end of which is stuck into a small hole drilled in the base of the upright stem. The upper end of the strut bears against a small boss on the lower edge of the frame, and by bending the strut up or down the frame and the glass can be set at any required height.

When there is anything to do to the lubricator, the little glass gates can be

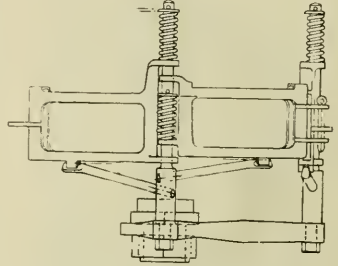

FIG. 1—LUBRICATOR GUARD FRAME

swung on one side out of the way or taken down altogether for that matter. The whole thing forms a very satisfactory protection for the engine crew against the effects of flying debris when one of the lubricator glasses "lets go." It does not prevent the drops of oil being clearly seen as they move and the occupants of the cab cannot help having something of a feeling of security as far as their eyes and faces are concerned where one of these shields is used.

The new addition to the Southern Shops, under construction at Knoxville, will be 175x750 ft. long and it is

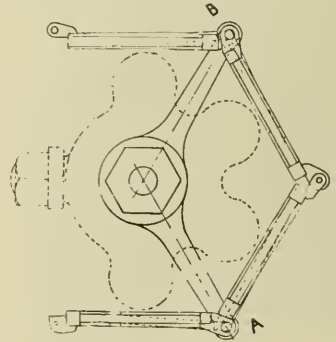
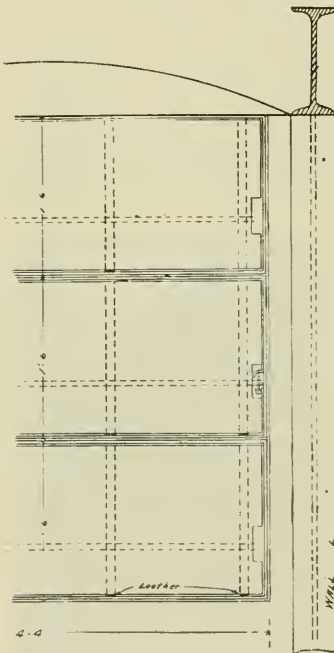

FIG. 2—PLAN OF GUARD SUPPORT.

to be equipped with all modern conveniences and machinery, which will make the whole plant one of the largest railroad shops in the country. At present engines from the Memphis, Birmingham, Tenn., and from the Central and Northern Alabama Divisions are being overhauled at Knoxville.



LOUVER OPENINGS, NEW YORK SUBWAY.

It is, in round numbers, 225 ft. deep and has an average width of 65 ft. The volume of this great building is 4,387,500 cu. ft. It therefore appears that within very close limits, the volumes of air in the subway from the Brooklyn Bridge to 59th street equal two Empire, added to three Trinity buildings, and the fans when all are working can draw off air at the rate of one Trinity building in 3 minutes and 3 seconds, and one Empire building in just a little less than 4 minutes, as the fans can completely clear the lower section of the subway in 17 minutes. North of 59th street and up to 96th street the air below ground is just about equal to one Trinity, plus one

# General Correspondence.

## Early Balanced Locomotive.

Editor:

Inasmuch as the balanced engine is rapidly coming into favor on American railways, and to give honor where honor is due, the following is timely from The Illustrated London News, of November 1, 1862, describing Austrian State Railway locomotive, "Duplex," exhibited at the International Exhibition, London, during that year:

"This locomotive is the first application of a doubled system of cylinders, pistons and cranks. By this means it is found on trial that the engine at a high speed works with greater steadiness than those constructed on the ordinary plan. The State Railway Company required twelve express engines to work safely over lines having gradients of 1 in 150, and curves 930 ft. radius. The conditions determined upon were that these engines should be built with an outside framing having three axles before the fire box, with 11 ft. 4 7/8 in. wheel base, the driving axle arranged before the fire box, and the driving wheels 6 ft. 8 3/4 in. diameter. The cylinders are placed outside, having each a diameter of 16 1/6 ins., 2 ft. 8 3/4 in. stroke; the wheels of the end axles acting as guide wheels, and to have on that account a greater load than the middle pair, and the greatest load (12 tons 6 cwt.) to rest on the driving wheels; the heating surface is 1,344 sq. ft. Mr. John Haswell, the director of the locomotive mechanism connected with these lines, proposed to build one of these engines with four cylinders and four cranks instead of two, but with all other parts and proportions in exact conformity with the other eleven engines, and nothing could be more interesting than this experiment. In compliance with this proposal the Duplex of the exhibition was built. It differs in no respect from its compeers except having four cranks and four cylinders before alluded to, and arranging the hind axle as the driving axle, by which means it was intended to insure a steady working of the locomotive. The double cranks on the driving axle look small in proportion to the usual dimension of such work, but the diminution in size is owing to the employment of Krupp's steel in the forgings of several working parts of this engine. In working railways there are three several motions acting in unity, and forming compound motion, influencing at high speed the steadiness of the locomotive when in a state of forward progression. These motions produce a

great effect not only on the permanent road, but also on the engine itself. This description of motion is termed swing-jerking, rocking and side swinging. To lessen the effect produced by these injurious actions the Duplex was designed, and one of the great objects sought to be obtained was that of diminishing, or nearly superseding, the use of balance weight usually placed on the driving wheels of locomotives. Although there are objections to working with four cylinders where two will perform the duty, the disadvantage is counterbalanced by the steadiness of motion and diminution of wear and tear at very high velocity,

Along the coast of California called the Mussel Rock Bluffs between San Francisco and Santa Cruz there is an electric road being built, and at these bluffs huge masses of overhanging earth and rock had to be taken down by the slow and careful process by which man is compelled to work. He was doing it all right with pick and shovel and a few sticks of dynamite at a time. When Dame Nature decided to shake things up in that region on April 17 last, she incidentally shook down this overhang and did the work quicker and better than the contractors could have done it, though she only



THE "OVERSEAS LIMITED." CANADIAN PACIFIC RAILWAY.

and which the Duplex, on the several trials made, seems to have accomplished satisfactorily." JOHN A. SHIRLEY.

*San Antonio, Tex.*

## Construction Work Rushed.

Editor:

There is an old saying, "It is an ill wind that blows nobody good." We are not surprised at the wind doing good now and then, for we know it propels sailing ships and drives windmills and performs many useful acts, but it is not often that an earthquake is found to fill a long felt want in our human work-a-day world. The San Francisco shock, however, seems to have saved the Ocean Shore road some \$15,000 in cash,

worked at it for a few seconds. Although the bluff was turned into something like a sloping hill, other parts of the road were more or less damaged and undoing that part of the work of the earthquake will cost something. When the accounts are balanced up, perhaps the earthquake may have something to its credit for the Mussel Rock bluff job, but it will not get any official thanks. ONLOOKER.

*Santa Cruz.*

## Points of Driving Wheel Slip.

Editor:

I was much interested in reading a communication in the June number of RAILWAY AND LOCOMOTIVE ENGINEERING, by "Technology," referring to an article

in the April number of your journal under the caption of "Causes of Engines Slipping," by Mr. E. C. Allen.

"Technology" is certainly right when he says the weight is increased on drivers by the vertical component of the side rod thrust, but when he goes on to say "the resistance to slipping increases directly with the increase in diameter of drivers," he makes a statement that cannot be reconciled with the accepted laws of friction.

The laws of sliding friction are to the effect that if the area of the surface in contact is doubled, without increasing the total weight or pressure,

drivers, total weight on drivers being the same in each case, the driver weight on rail in the case of the smaller drivers, it would be borne on one-half the rail area that obtains in the case of the larger drivers and while the matter of placing an immense weight on a reduced area on the rail would be destructive to both rail and driver, still regarded solely from the standpoint of maximum adhesion, owing to the "biting" and the abrasion that would result this particular arrangement would certainly give the greatest tractive effect.

Apart from the matter of minimizing

piston rod, this particular effect being manifest only when the piston rod is in extension; the positions of both cranks in the accompanying sketch is such that this reduction of total effective pressure on both piston heads is eliminated. As a driver will slip when an attempt is made to accelerate the speed of a train (to get it under headway) in too short a time, as by opening the throttle too wide at first, so when the point of greatest turning effect is reached, by virtue of the position of the cranks at this point the tractive effort will be superior to the adhesion and the drivers will slip. So it appears to be a logical deduction that slipping should occur on the lower  $\frac{1}{8}$  and  $\frac{3}{8}$ , owing to the greatly increased turning effect at these particular points in the stroke.

T. H. REARDON.

No. Adams, Mass.

#### Safety Hanger for Equalizer.

Editor:

I am enclosing you a sketch of a safety hanger for an equalizer that Mr. Wm. Henry, Master Mechanic of the 3rd District, Frisco System at Cape Girardeau, Mo., is having applied to the 2-6-0 engines that have frames which are too light to permit of cutting a slot through the frame for the equalizer, without weakening frame to such an extent that it would be liable to break.

Referring to the sketch you will notice that the hanger on the end that passes over the equalizer is bent in the shape of a hook, and the end that fastens to frame has a lip which hooks under the frame which takes the strain that would otherwise tend to shear the stud which holds the hanger in place. In the end view of this appliance you will see a 1-in. bolt bent at right angles, one end resting on the frame, the other fastened to the hanger. The ob-

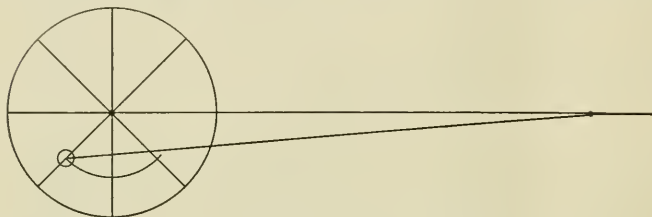

FIG. 1—LEFT SIDE LOWER  $\frac{3}{8}$  POSITION.

the amount of friction is unaltered, and also if the area of surface in contact should be reduced to one-half, the total weight or pressure remaining constant, the friction, would likewise remain the same, it being understood, that the area of surface in contact is not reduced to such an extent, in proportion to the pressure between surfaces, that cutting or abrasion, would result, in which case the resistance to slipping would be increased instead of diminished; in this particular instance the deductons made by "Technology" are at variance with facts.

The actual area of contact between the driver and the rail is something that mathematics cannot determine; geometry would say that the area between the driver and the rail was a mathematical line, but as the problem involves a consideration of the compressibility and elasticity of metals, it is beyond the scope of mathematical deduction. However, it is perfectly logical to assume that whatever the area between a driver and the rail may be, if we double the diameter of the driver we double this area.

According to the laws of friction, doubling the area of contact, without increasing the weight or pressure between the surfaces would not change the frictional effect in the least. A locomotive with four drivers should be exactly as well off as a locomotive with eight drivers as far as adhesion to the rail is concerned, provided the four drivers placed as much weight on the rail as the eight drivers did in the other case.

With three-foot drivers and six-foot

the wear and tear of drivers and track as well, practical considerations show that better results in a general way are obtained by increasing the number of drivers rather than by increasing the weight borne by a limited number of drivers.

In regard to slipping at particular points in the stroke, there is one particular point at which the turning effect on the drivers should be at a maximum; the crank values at two-eighths points is the maximum leverage obtainable.

The value of the leverage of the crank in eighth position is .7071 of its full value, which it has in the 90 degrees, or quarter position. Now call-

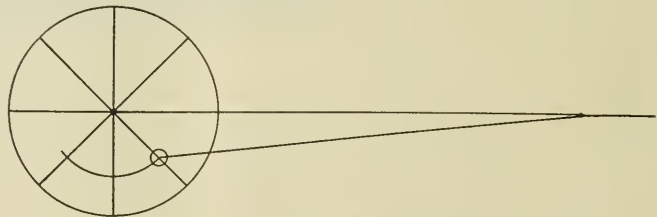

FIG. 2—RIGHT SIDE LOWER  $\frac{1}{8}$  POSITION.

ing the value of one crank in its 90 degrees position unity or the leverage value of two cranks in their positions of eighths will be 1.414, i. e., the turning effect with two cranks on the eighths, is 1.414 times as great as it is when one crank is on the quarter and the other crank on the dead center; furthermore as the area of the piston head is reduced in regard to steam pressure by the cross section of the

ject of this bolt is to hold the equalizer up in case of broken spring hangers, Mallet Articulated engine, and from of broken equalizer-stand bolts, the safety hangers prevent the equalizer raising up and clamping the reach-rod which would render the reverse lever useless. Frequent breakage of this kind lead to this improvement.

In speaking of the hangers Mr. Henry says, "The arrangement cer-

tainly performs the work intended, as when the various breakages mentioned have occurred brackets as well as the stops carried spring rigging to the terminal just as if nothing had occurred.

**Spring Split Switch.**

Editor:

When I was traveling in the West I saw on one of the railways out there a spring arrangement for a split switch

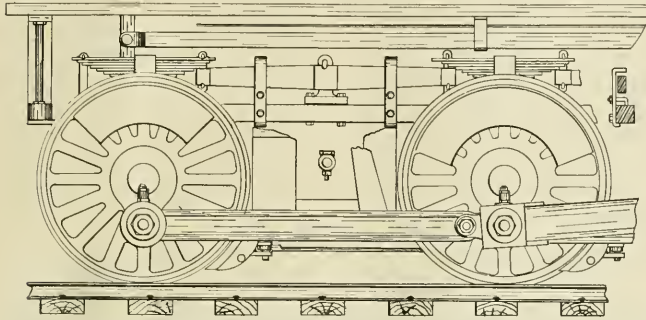

SAFETY HANGER FOR EQUALIZER ON LIGHT FRAME.

For the past 10 months we have avoided delay, and have not been charged with failures." Taking in consideration the use of scrap material for making the hanger, the simplicity and light cost of applying, one can readily see how

which I thought might interest your readers and I made a sketch of it for you.

The switch stand and the rails and everything about it is like nearly every other switch in the country, but the switch rod, that is the one from the crank to the rail, has, in this instance, been cut in two, and the ends joined by a flat spring folded something like the pleating of a lady's dress. The

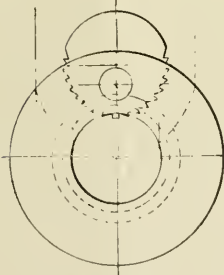
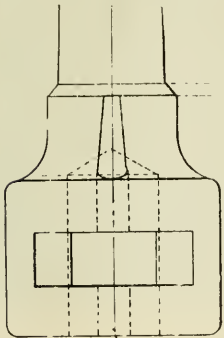

FIG. 1—STAYBOLT WRENCH.

one engine failure would more than pay for the cost of applying.

JOHN F. LONG,

Gang Foreman Frisco System.

Monct. Mo.

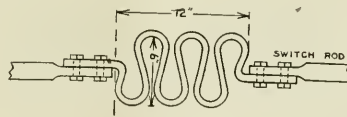

ELONGATING SPRING ON SWITCH ROD.

spring is bolted at each end, and forms part of the switch rod, the folds being about 6 ins. wide and the spring is made out of 4x3/8 steel. When it is in place it occupies about 12 or 14 ins. in length.

The spring is made compact in this way, the loops touch each other so that the spring cannot be compressed and the switch rod is therefore practically solid for normal traffic over the switch. If a car or engine backs through the switch, down the wrong track, the rails fly over and the spring in the switch rod opens out or extends, and when the car or engine has gone through, it closes up and puts the switch rails back to where they were. I did not see it on main line track, but it was on some inner siding switches and in the yard. What do you think of it? It has no doubt saved some runs off and so lessened the sum total of grief which goes along with the modern railroad life.

TRAVELER.

Yonkers, N. Y.

**Automatic Staybolt, or Stud Wrench.**

Editor:

I send you a sketch of a staybolt or stud adjustable wrench, which I got up some time ago and which has been very successfully used in the Denver & Rio Grande shops at Denver, Col. It is not patented, so anyone who so desires can make a similar article. The sketch, Fig. 1, shows an ordinary socket wrench with a round hole drilled or cast in it, also provided with a Morse twist drill taper to fit air drill, or it can be made with a square shank the same size as those on staybolt taps, so both will fit same socket.

The body of this socket is provided

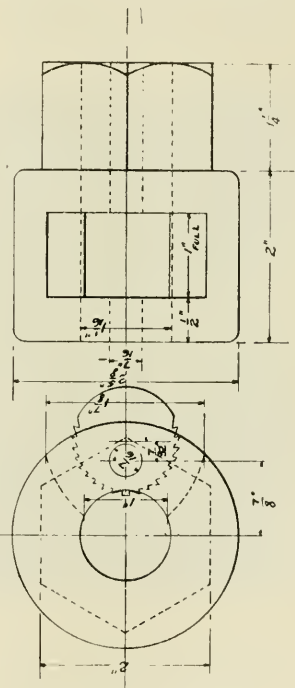

FIG. 2—STUD WRENCH.

with a slot, as shown, an eccentric roller, that fits loosely on a pin, and being made with slight taper is fitted tight into the body. The eccentric roller is provided with teeth pointing in opposite directions from the center line. The slot in body of the wrench is of sufficient length to allow the eccentric roller to move in opposite directions without permitting it to make a complete turn, so that it will adjust itself automatically either way and grip the bolt for screwing in or out. It can be made to suit bolts varying from 7/8 to 1 in. by 1/16, or from 1 in. to 1 1/8 ins. and 1 1/8 ins. to 1 1/4 ins. as desired.

The stud bolt wrench varies from

this by having an hexagonal head for a hand wrench, with hole through the body. It is shown in Fig. 2, the proper size for the various size stud bolts. It has a larger pin and a wider toothed roller.

HENRY BREITENSTEIN.

Denver, Colo.

### Traveling Engineers' Association.

The fourteenth annual convention of the Traveling Engineers' Association convened in the banquet hall of the Auditorium Hotel, Chicago, on August 28. That Chicago with its beautiful Lake Michigan, fine parks, extensive drives and numerous places of amusement, both within and without, together with a congenial summer resort temperature, are attractions to the engineers and their wives, is apparent from the frequency with which they gather in the "Windy City" as compared to other places of meeting. Again, that the traveling engineers do not allow the allurements mentioned to take them away from business is proved by the large attendance at the meetings, of four days' duration, with two long and very lively sessions each day.

#### OPENING EXERCISES.

The meeting was called to order at 9.30 Tuesday morning, President Beardsley in the chair, who introduced Rev. Mr. Williams, who offered a fervent prayer. Mayor Dunne was then presented and in an interesting address welcomed the traveling engineers, their wives and sweethearts to the city. The Mayor could not resist the temptation to refer to municipal ownership, a favorite theme of his honor, informing his auditors with apparent confidence that should they visit Chicago next year they would be privileged to ride on street railways operated by the city. At present, said the Mayor, the only municipal transportation facilities the city has to offer are ambulances and patrol wagons and while each is used to transport visitors, as well as those residing in the city free of charge, he hoped none before him would avail themselves of such municipal hospitality.

The Mayor found common ground upon which to stand with the traveling engineers when referring to the smoke nuisance by referring to the discomforts the people of the city experienced from locomotive exhalations, and the nature of the efforts being made for its suppression.

Supt. M. Power A. E. Manchester, of the C. M. & St. P. Railroad, also addressed the traveling engineers entertainingly, complimenting them on their achievements and giving them wise counsel. That he evoked their commendation was particularly manifested by the applause following his allusion to the time when every engineer owned his en-

gine. At the conclusion of the speech-making the convention was declared formally opened for business, the first in order being the reading of the President's address.

#### PRESIDENT BEARDSLEY'S ADDRESS.

Mr. A. L. Beardsley, of the Santa Fe, is president of the Traveling Engineers' Association. In addressing the convention he referred to the vast increase in railroad business during the past few years, and the greater responsibilities that had devolved upon traveling engineers in consequence of it. How the increased size of the locomotive has in some instances exceeded the capacity of the fireman as shown in many instances wherein modern locomotives have failed to exhibit expected efficiency. He pointed out that to obtain any further capacity to boilers the human limitation of firing capacity must be abolished, which implied a demand for the development of mechanical stokers, this being the only practical method of increasing the evaporation performance of boilers in large locomotives.

Among other things considered were the superheater, the balanced compound

Westinghouse Air Brake Company in its efforts to keep abreast of or even ahead of the rapid progress in railroads and in conclusion the president said: "The eyes of the railway world are upon us and our reputation is in our own hands."

"Many recommendations of the association have been adopted by the largest railroads and, as to ourselves, this association has been the means of raising our standard from practical obscurity to a position in the railway world."

The reports of the secretary and treasurer gave the gratifying information that the association now has a membership exceeding six hundred, and from a financial standpoint is in a healthy condition.

#### MR. CONGER'S PAPER.

The first paper presented was entitled "Committee Work on Reports from the Standpoint of Its Advantages to the Association and the Individual Member." To do the paper justice it should be given in its entirety, but lack of space forbids. It referred to committee work on reports from the standpoint of its advantages to the association and the individual member who prepares it; the enviable reputation won by the association for good reports, and the painstaking manner in which they are analyzed at the meetings and by the technical press, emphasized the fact that those who have not prepared reports fail to grasp many ideas which come to the committeeman who gathers the material and presents it in a way to fortify his assertions against those whose opinions may be at variance to his. It intimated that committee work broadens the mind, as in searching for new and valuable ideas the committeeman finds things to aid him in his work and thereby makes himself more valuable to his employer.

That proper support was not always given the committeeman is asserted and ways and means are suggested whereby much assistance can be rendered by answering the questions sent out instead of permitting them to repose in a pigeon hole, where the members of the committee below the chairman are but too prone to place them. Attention was called to the fact that the records of the association bear witness of promotion coming to many members who were prompt in getting out good reports by which talents were used which otherwise might have remained dormant. The paper urges the young member to do committee work and the veteran is called upon to donate his experiences and observations. The paper closed by stating that "this argument in favor of committee work may not meet the approval of all members," but that the writer was wrong in this conclusion was very evident, for the sentiments expressed by several speakers and the ver-

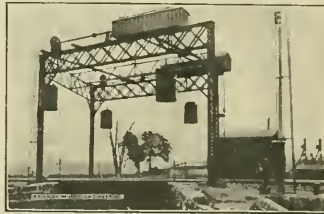

LIFT BRIDGE ON THE D. L. & W., OVER THE MORRIS CANAL.

engine, the Walschaerts valve gear and the softening of water for boilers, none of which had, in the speaker's opinion, been given the attention they merited.

The fact was emphasized that it devolves upon the traveling engineer, with the support of his superior officers, to further the advancement of these devices, develop and correct their deficiencies and train engine men to a thorough understanding of the principles underlying their operation. The responsibility of the traveling engineer, continued the speaker, is increased by the difficulty of securing suitable help and his duties are becoming more trying with the increased weight of motive power and rolling stock and which the operating officials are becoming aware of. The continued encroachment of electricity upon the province of the steam locomotive renders it expedient for the traveling engineers to inform themselves on electrical subjects and electric railway men should be urged to become members of the association. Attention was called to the great improvements made by the

dict of all present conclusively proved that the paper was most worthy of hearty endorsement.

MR. HARTENSTEIN'S PAPER.

The second paper, bearing a very old but always new subject, was entitled "Drafting of Locomotives." The paper opened by asserting the belief that ample steam pressure can at all times be maintained at the lowest possible fuel cost by designing a locomotive with sufficient exhaust clearance so that back pressure from exhaust steam is reduced to the minimum. Following this statement the conditions necessary to its accomplishment are presented. These are: Perfectly tight steam and exhaust pipe joints; smoke stack set centrally over the exhaust; draft pipe, if used, so located as to give proper opening at its

x26 in. cylinders, both types using Ohio run-of-mine coal which contains from 30 to 50 per cent. slack. As the tests covered only one road and type of front end arrangement, the members could hardly draw fair conclusions as to what such front end would do under the varying conditions obtaining on different railroads.

During the discussion following the reading of the paper numerous suggestions were made and the practice relating to front end arrangement of different roads presented, but at its conclusion there still appeared to be many skeptics as to the practicability of successfully establishing a standard front end and which was further evidenced by a negative vote on the motion "that there be a committee appointed by the

to Expense of Fuel, Wages and Repairs to Locomotives," and its salient points follow: The hauling capacity of locomotives in terms of tons is a product of hard times, during the years 1892 and 1896.

Prior to that time the engine was rated at certain number of cars regardless of the lading, but following the panic period referred to came the method now in vogue of rating the hauling capacity of engines by tons. The necessity of earning revenue has relegated small engines to the scrap heap and these have been replaced with the consolidation, the Mikados, Decapods, Mallet Articulated and others and with a traction power increase of from 15,000 to 70,000 lbs. Each step in the increase of size and power having raised antici-



GROUP OF DELEGATES TO THE TRAVELING ENGINEERS' CONVENTION AT CHICAGO, 1906.

top and bottom and set in line with the stack, thereby insuring uniformity of draft on the fire. The writer, by using the straight or taper exhaust box, finds that the exhaust steam is more retarded than when what is commonly termed a "pot" exhaust box is employed, and with the use of the latter a one-fourth inch larger nozzle is used.

The paper takes exception to claims that "the taper stack is a necessary feature in the drafting of locomotives," as the committee finds that by using an 18 in. straight stack the same results are obtained as with an 18 in. taper stack, and the former gives much longer service. Several tables of tests, made on a certain road are embodied in the paper which show the free steaming qualities of passenger locomotives with 18x26 in. cylinders, and 5 in. nozzle, also consolidation freight engines having 20

association to confer with a like committee of the Master Mechanics' Association with a view of bringing about a more uniform or standard front end and an increased boiler capacity for given sized cylinders than has the present locomotive." During the discussion the argument which apparently had much to do with the defeat of the motion was that relating to damage suits from fire, it being contended that should these mechanical associations go on record as indicated in the motion, it would place in the hands of attorneys representing claim interests a powerful weapon against railroads that did not, or for local reasons could not, use an arbitrary standard front end.

MR. F. W. THOMAS' PAPER.

The third paper read was entitled "Tonnage Rating by the Latest Methods with the Best Rating in Proportion

to Expense of Fuel, Wages and Repairs to Locomotives," and its salient points follow: The hauling capacity of locomotives in terms of tons is a product of hard times, during the years 1892 and 1896. Prior to that time the engine was rated at certain number of cars regardless of the lading, but following the panic period referred to came the method now in vogue of rating the hauling capacity of engines by tons. The necessity of earning revenue has relegated small engines to the scrap heap and these have been replaced with the consolidation, the Mikados, Decapods, Mallet Articulated and others and with a traction power increase of from 15,000 to 70,000 lbs. Each step in the increase of size and power having raised antici-

"tonnage rating" has an inharmonious sound. The methods of tonnage rating are as varied as are the railroads in number and the question of rating has drawbacks common to all such systems. The paper, however, covered the practice of the Santa Fe only and the methods employed on that road.

This is done first theoretically then proved by actual test, but to express the rating in such form that dispatchers, yard masters, foremen or switch crews and conductors can understand and interpret them proves difficult, especially as rating is often governed by the number of cars in the train when rolling resistance and other elements must be considered. The condition of the engine the writer would take into account, its capacity to handle full tonnage or less to be determined by the master mechanic and traveling engineer and until this is adopted tonnage rating will have its drawbacks.

The paper speaks hopefully of roller center and side bearings, it having been found that the tonnage can be increased about 7 per cent. on roads having occasional curves. Reference is made to the difference in power required to pull different trains of equal length and tonnage. Compound engines handle the greatest tonnage on grades, as the "Big Gun" or simpling lever is always at hand at critical times. Other points advanced were that full trains can be hauled cheapest on a double track owing to delays and expense of pulling in and out of sidings when using a single track; that the traveling engineer is anxious to reduce the cost of handling trains and that the engine and men handling it are earning the maximum amount for the company, but at the same time he is desirous of seeing that his engines are protected and given their just rating. Following the reading of this paper, in which the author set forth very ably the practical method of rating engines, and in a way to assist others in working out the problem suitable for their respective roads, as well as how to prove its practical application, the paper was opened for discussion. This was soon discontinued, however, and the subject of Westinghouse E T—engine and tender—equipment taken up.

#### NEW WESTINGHOUSE EQUIPMENT.

To clearly demonstrate and illustrate this equipment a large chart was employed, so arranged as to show the interior of the various devices with movable operating parts. As an introduction, reference was made to the weight and energy to be overcome with modern locomotives and trains as compared to those at the time straight air brakes were introduced, the speaker covering in a general way the constant demand for braking power and pointing out what had been accomplished in meeting the

demands by correcting and perfecting the apparatus, adding to it the appliances necessary to introduce elements heretofore known to be of great importance, though lacking. The noon hour having arrived, adjournment took place and upon the opening of the afternoon session,

#### AN OLD FRIEND SPEAKS.

Mr. Angus Sinclair, of RAILWAY AND LOCOMOTIVE ENGINEERING, was introduced as the traveling engineers' warm friend and a contributor to the formation of the Traveling Engineers' Association, and which had its birth in his New York office. He spoke in a happy vein of his efforts in bringing the organization about, his deep interest in its affairs and success since that time; depicted the great value of traveling engineers to the railroads; of the value of new blood in the association to perpetuate its work and prevent stagnation and closed by expressing the hope and faith that it would continue to be as energetic and useful in the future as it had been in the past.

#### THE E T BRAKE EQUIPMENT.

The subject of E T equipment now being resumed, several hours were spent in its elucidation, great interest being manifested by all of the very large number present and which was evidenced by the rapid fire of questions and answers constantly kept up and which were stopped only by a lack of time to continue.

#### TONNAGE RATING CONTINUED.

Upon again taking up the paper on "Tonnage Rating," numerous points were brought out not covered in the paper, such as classifying engines according to their condition, some favoring this while others contended the engine should be shopped when unable to handle maximum load; time element preferable to drag load; less cost per ton mile when making good time; drag load more severe on engine structure; effect of weather conditions in handling rates and percentage of rate reductions to meet such conditions; variations in train hauling a result of center and side bearing friction, etc.; definite tonnage, like standard front end, difficult of attainment; on long divisions both men and engines get tired and a large majority of freight engine failures occur during the latter portion of a long run, and effect of variation in quality of fuel. The subject was canvassed quite fully, and while somewhat diversified opinions prevailed, the discussion indicated quite clearly that the traveling engineers regard the question of tonnage rating a very important one and are most anxious to see a system inaugurated that will prove both practical and successful.

#### MR. C. C. FARMER'S PAPER.

Paper No. 4, "The handling of the Air Brake in Passenger Train Service to Avoid Break-in-twos, Discomfort to Passengers, etc." The points brought out in this paper relate to the good condition of brake equipment necessary to insure good service and the manner in which the traveling engineers can do much to bring it about; the unequal division of brake work, a result of varying piston travel and general condition of brakes on different cars in a train which necessitates heavier brake applications, reduces the reserve brake power, increases the liability of sliding wheels and the length of all emergency stops and unnecessary strain on the draft gear, all of which makes the work of the engineer more difficult; importance of good draft gear and the requirements to secure a comparatively uniform distribution of the brake power throughout the train. The paper proceeded to give with elaborate detail the proper method of handling brakes to derive the best results under the various conditions that obtain in train service.

Quite a discussion was indulged in regarding the best position in which to carry the engineer's brake valve handle when backing up and handling the brakes with a tail hose, particularly with engines having the E T equipment, and it was decided not to be advisable to adopt a recommended practice owing to local conditions.

#### B. & O. ARTICULATED COMPOUND.

Before taking up the next paper, a very interesting statement was given relating to the Baltimore & Ohio railroad Mallet-Articulated engine, and from which it appeared that the engine after making 57,000 miles in heavy pushing service showed but little signs of wear to the machinery and tires or deterioration of the boiler, while the flexible steam pipe joint has proven entirely reliable and satisfactory.

#### MR. F. P. ROSCH'S PAPER.

Subject of paper No. 5: "The Care of Locomotive Boilers at Terminals and While in Service." This paper covered a subject that is of vital importance to railroads, and will be printed in full in a future issue of RAILWAY AND LOCOMOTIVE ENGINEERING.

#### THE FUTURE ENGINEMAN.

The sixth paper bore the caption, "The Future Engineman. The Best Method of Increasing His Efficiency and Raising His Standard."

The paper opens by depicting the type of young men from which firemen should be selected in order that from them, in time, a good class of engineers may be had, the essential requirements being a good common school education, a fair amount of muscle hardened by physical

(Continued on page 474.)



The behavior of the man in charge of the ship had in it all the elements which go to make up the character of the chancetaker. He kept on doing the risky thing in the hope that it would turn out all right. The accident also revealed a state of affairs which is almost invariably the forerunner of final disaster. The getting through the channel just in the nick of time with no margin to speak of, appears to have been the rule rather than the exception, and this goes to prove what we have before now asserted, that the chancetaker is the natural outcome of laxity in the enforcement of that form of discipline which makes safety the supreme rule of conduct in all matters connected with transportation whether on land or water.

The necessary margin of time, the sober second thought, the desire to err, if need be, on the side of careful operation is nothing more or less than the transportation factor of safety, and it is as necessary in the movement of ships or railway trains, as that a boiler be made so many times stronger than its bursting pressure, or that a steel bar be capable of supporting more than just its normal load.

The lesson for those of us who are connected with train operation can as well be drawn from the overthrown Interstate bridge as from some terrible railway accident. The chancetaker works always toward one goal and though long delayed he is sure to receive his reward in the end. In the old mythology it was said that the feet of the avenging gods were shod with wool so that their approach should always be silent, and that they might surely steal upon their victim unawares. It amounts to a moral certainty that the man who disregards the safe course lets loose the very spirit of disaster, and is ever closely followed by her noiseless feet.

#### Apprentice Machinists.

Apprentices have a family resemblance to each other in one intellectual attribute. They are all going to do something great when their time is out. Those in the great industrial centers of the East are going to go West. Those in the West are looking toward the rising sun. Those in locomotive shops have visions of marine work. Some are going to go firing and become engineers in a very short time. They are like the squirrel that saw greener hills than his own. There is going to be something magical in the closing hours of the apprentice's last year. He may not be able to file straight now, but in that undiscovered country he will work miracles.

It is a good thing that the lamp of hope is easily kindled in the forehead

of youth. The evil of it is that it is apt to darken the present. Those of us who have seen the apprentice just blossomed into a journeyman, taking his departure from the old shop hardly dreamed that we would ever see him again. And yet when he comes back and gets a job in the old shop there is a fine air of chastened cheerfulness about him. The place he went to was full of malaria, or the old folks wanted him to come back. He is beginning to learn his trade now and in a year or two he will be ready to go out into the great world and take his place like a man.

The real trouble with the apprentice is that he rarely takes his trade seriously. He is working under compulsion, as it were, like a prisoner doing time. He is more interested in the day of his release than he is in the mastering of his task. When the foreman comes near him he is full of uneasiness and there is a load off his mind when the foreman has gone about his business. He rarely asks how to do a job. That would be a confession of ignorance and would be lowering himself in his own estimation. He stumbles along like a man walking in the woods, heedless of the well beaten track near by. What mind he has is elsewhere. He is either thinking of an increase of salary or of the vacation that he is going to get. His mercurial thoughts run into every channel except the right one, and the marvel is that out of the unskilled hands that he has, anything good could come.

The apprentice is not altogether to blame. Education in his calling is unthought of. The foreman has too much to do already without delivering lectures to inattentive auditors. The foreman is more anxious to get something out of the apprentice than to put something into him. The result is that they mutually despise each other, and there is very seldom any tears shed at parting. We rarely hear of the apprentice and his master exchanging gifts. Apprentices, in their want of appreciation, are like unto the ten lepers who were cured. One only of the ten came next day to thank the Physician.

There is, nevertheless, much hope for the apprentice; his worst time is over. The haphazard methods, or lack of methods, are passing away. Some of the larger railroad shops have special mechanical instructors whose duty it is to show young men how to work. At the shops of the Central Railroad of New Jersey there are classes in mechanical drawing, attended by all of the apprentices during the working hours of the day. Short lectures on machine construction and repair work are given, and the minds of the young men are brought into close contact with

the most accomplished, in the theory and practice of their trade. This fine example is being followed at other places, and there is good reason to believe that in the near future there will be as much pains taken to teach an apprentice his trade as there is in teaching a child that two times two is four.

#### Westward for the Far East.

At this time it is perhaps not too much to say that for the inhabitants of Great Britain the best way to go east is to travel west. The regular way to go from London to Hongkong was by what was called the Overland Route—that is, from London to the continent, and down to Brindisi by rail. If you look on the map, Brindisi is almost on the heel of Italy. Thence the traveler went by steamer to Suez and from there to destination by one of the P. & O. boats, as the Peninsular and Oriental Steam Navigation Company's steamships are called. Going this way the time occupied is about 35 days.

The route just opened up only takes 30 days, and by it a Londoner goes west to reach the Far East. The Canadian Pacific Railway own two Atlantic steamers, one of them, the "Empress of Ireland," left Liverpool on the initial trip August 24 and arrived in Quebec on the 31st, having made 3,009 miles. At 9 o'clock in the morning, one hour after the arrival of the "Empress," the "Overseas Limited," as the new C. P. R. train is called, began its run of 3,072 miles, and reached Vancouver 96 hours later by the clock and within an hour after its arrival mails and passengers were off for Hongkong on the "Empress of China," another of the company's fleet, with 7,160 miles before them.

The Overseas Limited in covering 3,072 miles, travels at an average speed of 33 miles per hour including stops. It is pulled across the continent by 23 locomotives and the cars are of the latest design. The total mileage from Liverpool to Hongkong via Canada is, in round numbers, 13,240, and this has been done by the through passengers with but two changes and only one checking of baggage. This distance is just about half way round the earth, and it is the longest transportation route under one management in the world. The train is called a "limited," but there is no extra charge on that account.

The train is spoken of as on a 96 hour schedule, but the actual running time going west is 93 hours. This difference is accounted for, because a traveler with his watch set to Eastern time would have to put it on one hour at Fort William, on Lake Superior, for Central time, and another hour ahead at Broadview, on the prairie, to be even with Mountain time, and once again at Laggan, in the Rock-

ies, for Pacific time. After the train begins its run, it just keeps on going until ocean, river, plain and mountains are behind it.

#### Railroad Ties and Spikes.

To take time by the forelock is an old proverb, signifying to seize an opportunity, and for the matter of that to have acted wisely and before it was too late. One would almost think that on the American continent there was not much need to be careful about the timber supply, nature has been so prodigal in her wonderful forest gifts. Destruction of the nation's heritage by fire and the enormous drain on our timber resources by the many and legitimate uses to which wood is applied, has brought us to the point where prudence is the doubly wise course.

The life of the railroad tie is the immediate question in which our land transportation companies are most interested, and the determination of some quickly grown and serviceable timber and the best means of artificially prolonging its period of usefulness are the aspects of the question which are probably the most important.

Experience in Germany has demonstrated the fact that beech ties can be kept in a serviceable condition for more than a third longer time if treated with the oil of creosote than they could without it. To put it more definitely, good, sound beech ties, which would last on the average 17 or 18 years, may be made to do duty for about 27 years if creosoted. The meaning of increasing the service life of railway ties and railway lumber even by one-quarter of their normal life may be appreciated when it is remembered that 84,000,000 ties are used annually and probably about three billion feet of lumber (board measure) in the same time.

Suppose a tie measures 10 ins. on top, and is 6 ins. deep and 8 ft. long, the yearly consumption in this country would make a solid pile, without an air space sufficient to hold a sheet of paper, containing 279,720,000 cubic feet. This enormous consumption represents the yearly denudation of vast forest areas, and that has to be made up in some way. Many of our larger railroads have taken up systematic tree growing, the favorite variety being the Catalpa tree.

An interesting side light on the value of different kinds of wood when used as railroad ties may be had from experiments on the holding power of spikes. Tests have recently been made by the Department of Agriculture at Washington in which three kinds of spikes were used, viz.: the common railroad spike, the channeled spike and the screw spike.

The common and the channeled spikes were driven into the ties in the

usual manner to a depth of five inches. A hole, of the same diameter as the spike at the base of the thread, was bored for the screw spikes, which were then screwed down to the same depth as the driven spikes. The average force required to pull common spikes varied from 7,000 lbs. in white oak, to 3,600 lbs. in loblolly pine, and 3,000 lbs. in chestnut. The holding power of the channeled spike was somewhat greater. About 11 per cent. more force, or 4,000 lbs., is required to pull it from a loblolly pine tie. The screw spike had a holding power ranging from 13,000 lbs. in white oak, to 9,400 lbs. in chestnut, and 7,700 lbs. in loblolly pine.

It was found that driven spikes did not hold well in knots, as the knots were brittle and lacked elasticity, in fact their holding power in knots was reduced about 25 per cent. Screw spikes tended to pull the whole knot out. This increased the holding power of screw spikes in knots, by about 35 per cent. over that for clear wood.

#### Book Notices.

Proceedings of the Thirteenth Annual Convention of the Air Brake Association, Held in Montreal, Canada, 1906. Published by the Air Brake Association. Flexible leather covers. Price, \$1.00.

This book contains 296 pages and is well illustrated throughout. It gives a verbatim report of the papers read at the meeting and the discussions which followed. A full list of members with addresses, which is given in the alphabetical order, shows that the association is in a very prosperous way. There is in the back of the book a table of contents of the convention proceedings since 1894, which forms a valuable reference department. The book may be procured at the office of RAILWAY AND LOCOMOTIVE ENGINEERING, 136 Liberty street, New York.

Complete Examination Questions and Answers for Marine and Stationary Engineers. Published by F. J. Drake & Co., Chicago. Price, \$1.50.

This book is in catechism form and contains 800 questions and answers, and is fully illustrated. An alphabetical index is appended for reference. The book contains 354 pages, 7x4½, and it is bound with flexible leather covers. This book aims to give the latest and most approved answers to all questions likely to be asked in examinations of applicants for licenses as engineers, or for persons having charge of steam boilers, as approved by municipal and government boards of examining engineers, both stationary and marine.

Wiring a House. By Herbert Pratt. Published by the Derry Collard Com-

pany, New York, 1906. Price, 25 cents.

This is one of the Practical Paper Series which is got out from time to time by this company. It is the work of a practical man who has planned and wired many dwelling houses and other buildings. It begins right at the beginning and shows just how each step is taken, all the way through, and is intended to help a man who wants to do this work himself. The book is well printed on good paper, has 20 pages, and has proved to be very popular.

General Specifications for Steel Railroad Bridges and Viaducts. By Theodore Cooper. Published by The Engineering News Publishing Company, New York, New and revised edition, 1906. Paper covers. Price, 50 cents.

This is a neat little compendium of specifications for railroad bridges and is the work of a man who has during the last quarter of a century been actively engaged in the work of which he writes. The author's first specification was prepared many years ago and since then he has revised them continually to meet the ever increasing demands made for the building of larger and more important structures. The present work is thus the result of a ripe experience, and the application of present day practices to meet present day needs. "Bridges of the future," he tells us, "must be relatively better than those of the past. Any false economy gained by scripping the details or using an inferior class of material will not redound to the credit of the bridge engineer."

General Specifications for Steel Railroad Bridges and Structures with Sections, Making Them Applicable to Highway Bridges and Buildings. By A. W. Buel. Published by the Engineering News Publishing Company, New York, 1906. Paper covers. Price, 50 cents.

These specifications have been prepared under the direction of Mr. V. G. Bogue, by the author, and he tells us the work has been done with the purpose of combining such rules governing the design, workmanship and quality of material that steel structures built in accordance with them will be first class in every respect and up to the standard of present practice and yet be constructed as economically as possible under the circumstances. The book contains 61 pages and concludes with an extensive series of engineering tables.

The Chicago Pneumatic Tool Company reports the month of August to be the heaviest in the history of the organization, both in business booked and shipments made, the latter exceeding all previous monthly records by 15 per cent.

**Shop Sulky.**

A very useful and simple general utility shop carriage is to be found in the Columbus, Ohio, shops of the Hocking Valley Railway, of which Mr. S. S. Stiffey is superintendent of motive power. The shop carriage is a self-contained affair and can be used alone or in conjunction with another of its own kind.

The truck or carriage or whatever

may be pardoned for so saying, when it hunts in couples, and it was probably intended to be used in pairs by Mr. Gummere, the air brake expert, at the shops when he got it up. Observe the method of attack, when a pair of wheels mounted on an axle are to be moved to or from the wheel press. Two men each pushing one sulky approach a pair of wheels from opposite

made and have done a lot of good work without ever having said a word about only making so many miles between shoppings and they have never been known to so much as mention a thing about the fatigue of metals.

**Water Tube Locomotive Boiler.**

Considerable interest has been manifested in regard to a water tube locomotive boiler exhibited at Milan, Italy, designed by M. Robert, chief engineer of the Paris, Lyons and Mediterranean Railway. The ordinary type of locomotives never gave complete satisfaction on the Algerian lines, owing to the inferior quality of the water. Staybolt and other fractures were constant while cracks developed rapidly in the fire box plates.

As will be seen in our illustration the outside appearance of the Robert boiler is the same as that of an ordinary locomotive boiler. The boiler proper is formed of a mud drum and a steam drum, connected by three circular uprights. The steam drum is extended to the rear of above the fire box, and is fitted at the top with the steam dome connected by return tubes to a feed collecting hollow frame at the bottom of the fire box. The sides of the fire box are lined by return tubes placed close together, expanded in the hollow frame and in the steam drum. The drums are connected by curved tubes.

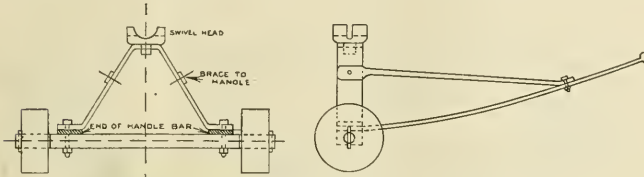

SHOP SULKY OR GENERAL UTILITY PONY TRUCK.

you like to call it, consists of an axle, a pair of wheels like a racing sulky, but it does not travel quite as fast. It has a handle bar terminating in a tee at the front end and a fork at the back end where it joins the carriage. On top of the axle is mounted a piece of flat iron bent up into a sort of inverted V-shape, and carrying on its apex a grooved piece of iron and this has a round boss on its under side which drops into a hole in the V-shaped frame. The grooved piece can turn around like the top of an ordinary screw jack.

ends of the axle. They have the swivel heads of their machines so fixed that the journals will lie in the large round grooves. They each back up and tilt the grooved tops under the journals and tilt up again and the journals are comfortably caught by the round grooves and the collars get into the cross slots and the wheels are up in the air in a minute. The axle thus forms the connecting link between what we must now call the pair of two-wheel pony trucks, and one man pushes and the other pulls and away go the wheels.

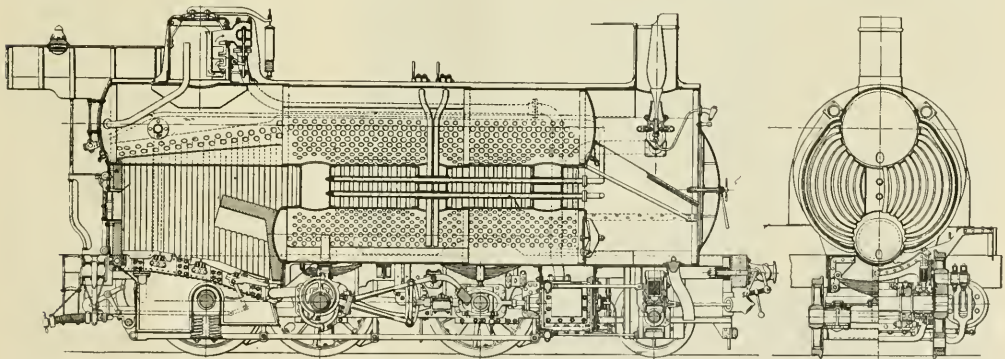

ROBERT WATER-TUBE BOILER FOR P. L. M. RAILWAY.

M. Robert, Chief Engineer.

Engraving Reproduced from "Engineering."

The round groove in the top piece will about fit a car journal and so easily holds a bar or the edge of a flange of anything that may be put into it and as it turns round on its axis, it accommodates itself so as to suit a lot of things. There is another groove in this top piece or swiveling head, cut at right angles to the round groove, and this is a square slot that just about fits the collar of a car journal or anything like that.

This shop sulky is at its best, if we

The whole thing, axle wheels and all, can go round in a curve and so turn a corner because the swivel head takes care of that kind of motion as well as holding the axle safely. The trucks can dip their swivel heads under the handles of a steel basket and go off with a very decent sized load between them if need be. Bolsters and bars and a variety of things get moved about in the Columbus shops of the Hocking Valley with very little trouble, and these trucks are simply and strongly

those in front and rear of the fire box being of large diameter steel tubes and covered by a fire brick lining. The steam and exhaust pipes are arranged in the usual way in the smoke box.

The result of the experiments with the Robert water tube boiler has shown that while the old type of boiler had to be thoroughly overhauled after the engine had run about 20,000 miles, the Robert boiler maintains its efficiency over 80,000 miles. A high degree of evaporation is said to be maintained,

and the locomotive, it is claimed, is capable of hauling 25 per cent. more than those of ordinary type with equal grate area and heating surface. The total heating surface amounts to 1,165½ sq. ft. of which 172.3 is in the fire box. The grate area is 19.4 sq. ft. and this gives a ratio between grate and heating surface of 60.

#### Fifty-Ton Trolley Wagon.

The North-Eastern Railway, of England, have recently built for their own use what they call a 50-ton trolley wagon, which we are able to show in our illustration through the courtesy of Mr. Wilson Worsdell, the chief engineer of the road.

The car, as we would call it, is made entirely of structural steel shapes and is for the carriage of heavy steamship or other bulky material which can be loaded upon the girders about 24½ ins. above rail level. This is important where head room is limited. The side sills of the car are made in the form of two box girders composed of plates and angles. There are two similar box girders forming the center sills made of channels and each of the four girders is 12 ins. wide and 16½ ins. deep. They are spaced 15 ins. apart, so that the total width of the car is 7 ft. 9 ins. The car is 38 ft. 6 ins. long between centers of bogies, and the total overall length is 48 ft. 8 ins. The well in this car is 25 ft. long and 2 ft. 7¾ ins. deep.

The raised ends of the car over the bogies are each in reality two frames, in which the side sill girders are continuous in form. The body bolsters are also box girders made of 3½x12½ in. channels. They contain heavy ball and socket shaped center castings, and

building. There is no deck on the depressed girders and there is none on the raised ends. There is, however, a ¾ in. plate riveted to the underside of the depressed girders and this forms a sort of sunken floor which would prevent any loose parts of the article being carried from being lost. In this respect it resembles the General Electric car, which we showed on page 231 of our May issue and in

Eastern car has, however, a journal and oil box on each side of every wheel. There are eight wheels and sixteen journals. The inner boxes are easily got at through the openings between the frames of the raised ends of the car. The truck frame is made of double web plates placed vertically one inside and one outside of each wheel. There are no cover plates over these webs, and on each of the sixteen boxes there are

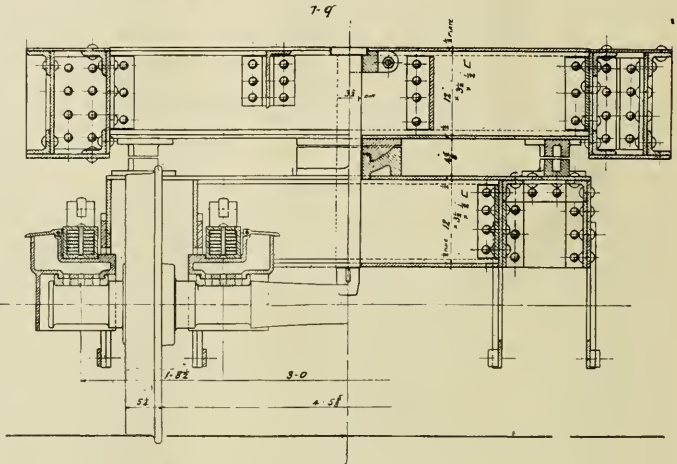

END VIEW AND SECTION THROUGH BODY BOLSTER, N.-E. RY.

which the car well had a curved bottom, for practically the same purpose.

Last month we showed on page 417 a Pennsylvania flat car which is used for the carriage of heavy electrical machinery. The P. R. R. car has a short deck at each end and two side sills of the box girder type carried above the

bearing semi-elliptical springs, made of 7 leaves 4x½ in. steel. The truck or bogie wheels have a spread of 5 ft.

The pull of the draw gear is against the inside face of the end sill, which consists of a 1 in. plate 17¾ ins. deep, held by the side sills, the web plates in line with inner faces of the center sills, and a pair of diagonal braces to the body bolster. The draw bar pulls against a heavy steel casting, which covers two sets of friction discs which bear against the end sill. The buffing shocks are taken up, as is usual in English practice, by a pair of heavy buffers placed in line with the inner webs of the side sill girders. The center sill girders are diagonally braced on the truck side of what we have called the vertical plate wall of the well. The whole car forms an interesting study in special car design.

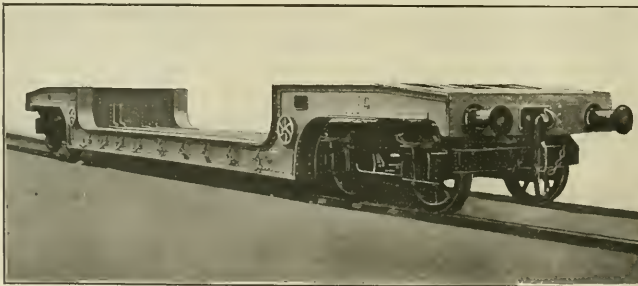

NORTH-EASTERN RAILWAY, ENGLAND. 50-TON TROLLEY WAGON.

from the deck line 3½ in. center pins keyed at the bottom, pass through them. In the raised car ends there are two web plates which are cut off at the vertical walls of the well. The center sill girders are supported by brackets attached to the well walls. The whole car thus forms a good example of what may be called bridge construction as applied to car

truck level. The North-Eastern car has four box girders depressed below truck level and the raised ends are open and sloped slightly toward the end sills. The wheels are 38 ins. in diameter and the axles have 8x5½ in. journals, which are enclosed in specially designed boxes, which are oiled from a chamber above the journal. Oil is syphoned in as it is in driving boxes. The North-

Appointed to Investigate.  
Mr. Angus Sinclair, the well known automobile authority and editor of RAILWAY AND LOCOMOTIVE ENGINEERING, has been requested by the United States Department of Agriculture to conduct a study of the value of alcohol as a fuel for the generation of power and to make a report on the subject and also to include in it a critical survey of the literature on this subject in Great Britain.

# Our Correspondence School

In this department we propose giving the information that will enable trainmen to pass the examination they are subjected to before being promoted. If any of our students fail to understand any part of the instructions, we will gladly try to make them plainer if they write to us. All letters intended for Our Correspondence School ought to be addressed to Department E.

## Third Series—Questions and Answers.

101. When one tap of the signal bell is heard while the train is running, what must the engineman do?

A.—He must look out for his train having broken in two and govern himself accordingly.

102. What significance will signals of the same numbers of sounds have when given by other appliances than bell cords and signal bells?

A.—When given by air whistle they will have the same significance.

103. What is the lamp signal to stop?

A.—Lamp swung horizontally across the track.

103a. What is the signal to move ahead?

A.—Lamp raised and lowered vertically.

104. What is the signal to move back?

A.—Lamp swung vertically in a circle at arm's length across the track when the train is standing.

105. What is the signal that the train has parted?

A.—Same signal given when train is running.

106. May these signals be given by any other means than the lamp? If so, by what means?

A.—Yes; they may be given by hand or flag.

107. How should a signal imperfectly displayed, or the absence of a customary stationary signal be regarded, and what is your duty in regard to it?

A.—It should be regarded as a stop signal, and promptly obeyed as such, and the fact of its imperfect display or absence should be reported to the proper officer.

108. State fully when the whistle should be sounded?

A.—It should be sounded in strict accordance with the whistle signal rules given in the standard code. Great care should be taken in stormy weather to make these signals clear and distinct.

109. How should a danger signal, other than a fixed signal, be acknowledged by the engineman?

A.—By two short blasts of the whistle.

110. At what points must the whistle be sounded?

A.—When approaching public crossings at grade or on approaching stations, junctions and railroad crossing at grade, also at all whistling posts and at any point, or points designated by the special rules, or instructions of the railway you are employed by.

111. Where must the engine bell be rung?

A.—At all points where the whistle is sounded as a warning, and when engine is about to move.

112. When two or more engines are coupled to the head of a train, where should the classification signals be displayed?

A.—They should be displayed on the leading engine.

113. If only one flag or light is displayed as a classification signal, how must it be regarded?

A.—No.

117. When a train turns out to be passed by another, what change must be made in the markers?

A.—The marker lights at night must show green toward the engine, the side and to the rear.

118. When must the markers be again changed so as to display red to the rear?

A.—When the train for which the change in the markers was made, has passed.

119. When should headlights on engines be covered?

A.—The headlight must be covered when a train turns out to meet another and has stopped clear of the main track or is standing to meet trains at the end of double track or at junctions.

120. What signals must be used to stop a train at a flag station designated for such a train?

A.—A combination green and white signal.

121. What signal must be used to stop a train at a point not a flag station?

A.—A red signal must be used.

122. At what points are torpedoes not to be placed?

A.—Torpedoes should not be placed near stations or crossings where people pass them.

123. What is your duty with reference to looking out for signals?

A.—To be always on the sharp lookout for signals.

124. How are trains designated?

A.—They are designated as regular or extra trains.

125. What is a regular train?

A.—A regular train is one authorized by a time-table schedule.

126. What is a section?

A.—A section is one of two or more trains, displaying signals, or for which signals are displayed.

127. Is an engine in service on the road considered to be a train?

A.—Yes.

128. How many classes of trains are

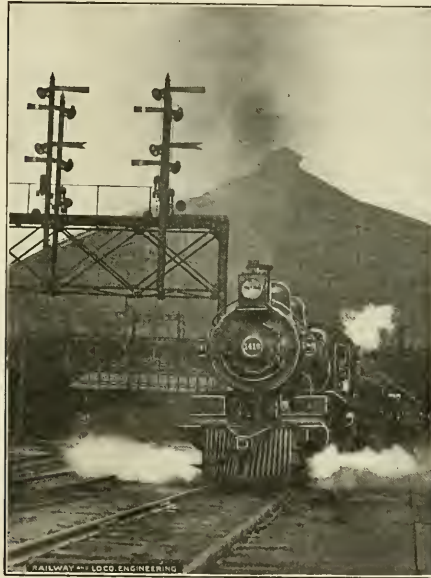

THE START—PENNSYLVANIA SPECIAL LEAVING JERSEY CITY TERMINAL.

A.—Its indication is the same as if two had been displayed, but the proper display is required by the rules.

114. Who are responsible for the proper display of all train signals?

A.—Conductors and enginemen.

115. When a train is being pushed by an engine at night, or when the train is obscured by a fog or other cause, what signals must be displayed, and where?

A.—A white light must be displayed on the front of the leading car. A flagman must take a conspicuous position on the front of the leading car.

116. Is this required in shifting or making up trains in yards?

there on the current table of this division?

A.—Answer according to the trains shown on division time-table of your road.

129. State the relative rights of each class?

A.—Trains of the first class are superior to those of the second; trains of the second class are superior to those of the third, and so on.

130. How are extra trains distinguished?

A.—Extra trains display two white flags and in addition, two white lights by night in the places provided for that purpose on the front of the engine.

131. Extra trains are of what class compared with regular trains?

A.—They are of inferior class to regular trains.

132. What is required of a train of inferior, with respect to a train of superior class?

A.—An inferior train must keep out of the way of opposing superior trains, and of superior trains going in the same direction and failing to clear the main track by the time required by rule, must be protected as prescribed by Standard Code, rule No. 99.

133. In which direction have trains the right of track over opposing trains of the same class on this division?

A.—This is according to the special rule of the railway company.

134. Where is this authority to be found?

A.—This is in accordance with the special rule of the railway company.

135. Are there any exceptions made to this rule? If so, where are they noted?

A.—This is in accordance with the special rule of the railway company.

136. When trains of the same class meet, what is the duty of the train not having the right of track?

A.—The train not having the right of track must clear to main line before the leaving time of the superior train. At meeting points between extra trains, the train in the inferior time-table direction must take the siding, unless otherwise provided.

137. If you are obliged to run by a siding and back in, how would you proceed?

A.—A flagman must be sent ahead with stop signals, a sufficient distance to insure full protection. When recalled he may return to his train, first placing two torpedoes on the rail when conditions require it.

138. How long must a train clear the time of train of superior class at a meeting or passing point?

A.—An inferior train must clear the time of a superior train not less than five minutes, but must be clear at the time a first-class train in the same di-

rection is due to leave the next station in the rear where time is shown.

139. How long must a train wait at a station before starting, after the departure of a passenger train in the same direction, when no form of block signal is used?

A.—This is in accordance with the special rule of the railway company.

### Calculations for Railway Men.

BY FRED H. COLVIN.

#### SCREWS, BOLTS AND WEDGES.

The close relation between the inclined plane and the screw can be seen in Fig. 1, where the sketch shows part of

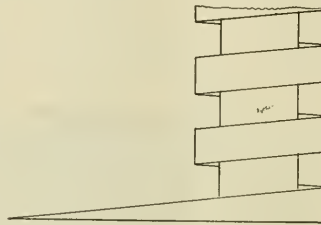

FIG. 1.—SCREW IS AN INCLINED PLANE.

a thread unwrapped and the bottom cut off straight or at right angles to the center of the screw, showing just what the incline really is.

In the screw jack or any other application of the screw, the load or nut is raised by the continuous inclined plane being forced into or under it. The way this is done and the power it will exert was shown in the last issue.

Every man who has anything to do with bolts and nuts, knows the seeming ease with which they sometimes twist off and also the work it makes in too many cases. While we often lay it

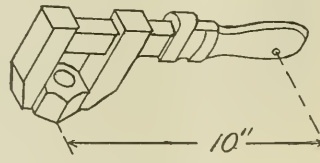

FIG. 2.—MONKEY WRENCH AS A LEVER.

to the poor material in the bolt it would probably be nearer the truth to say we did not judge the pressure we applied correctly.

Take a  $\frac{7}{8}$  stud or bolt as shown in Fig. 2 and a 10 in. monkey wrench, the 10 ins. being measured from the center of the handle to the center of the nut we are tightening up, and we have a combination that often comes up in the shop, although it is not an unusual thing to see a much larger wrench to a nut of this size.

Now a  $\frac{7}{8}$  bolt is only .71 of an inch at the bottom of the thread and has an

area of only .39 of a square inch at this point. Going over the same calculations as before we find that the power is applied through a distance of 31.416 ins., and as there are 9 threads per inch we have 9 times 31.416 or 282.744. Calling the power only 20 lbs., and we have  $20 \times 282.744$  or 5,655 lbs.

Calling the breaking strength of the material 50,000 lbs. per square inch, we multiply it by the area of the bolt under the thread, which is .39, and find that it would break at about 19,000 lbs. or a little over three times the pressure we apply with only 20 lbs. pull on the wrench.

A strong man will pull much more than this and it is not hard to discover why bolts give way, especially as we seldom content ourselves with a wrench as short as this.

It is often necessary to know how to find the depth of a thread for various purposes, such as finding the diameter at the bottom of the thread. A V thread of 1 in. pitch (one to the inch) is .866 of an inch deep, so to find the depth of any other thread we divide .866 by this and in this way we find that a 9 thread is .097 deep. This is for one side only and to get both sides we double this and find that it is .194 of an inch. Deducting this from the outside diameter or  $\frac{7}{8}$ , or .875 of an inch, we have .681, which is less than we counted on before, but the .71 allows for the thread not being quite sharp, as it seldom is.

For a U. S. Standard thread, which is flat top and bottom, we take off  $\frac{1}{4}$  the depth ( $\frac{1}{4}$  top and the same amount from the bottom) and use the figures .65 as the depth of a thread having 1 in. pitch. Divide this by the threads per inch and you have the depth of the thread you desire. In fact there are very few threads which are made absolutely sharp and it is better to allow for a little flat, especially at the bottom, even of a so-called V thread.

These figures are especially valuable to the lathe man, who has threads to cut inside any hole, as he must know how large to make the hole in order to allow for the depth of the thread.

Suppose you have a large nut to bore and thread for a rod or bolt having 6 threads per inch. If the rod is 4 ins. outside diameter, what should be the diameter of the hole before you commence cutting the thread?

If you desire a sharp V thread, divide .866 by 6 and find that each side is .144 of an inch deep, so you must deduct twice this, or .288 from 4 ins., leaving 3.712 as the correct diameter to bore the nut. In real work you will be perfectly safe in boring it a little more than this, almost  $\frac{3}{4}$ , as the metal will be forced up from between the threads and make it practically sharp. For ordi-

nary use it is better not to have it quite sharp, and very few threads are cut that way now.

If the thread is to be United States Standard, we divide .65 by 6 and find that the thread on each side is .11 of an inch or .22 in all. Deduct this from 4 ins. and we find that the correct diameter for boring is 3.78 ins. or a trifle over 3/4.

## Questions Answered

### SQUARING AN ENGINE.

(87) C. R. W., Caryville, Fla., asks:

If I get the centers of both cylinders with back heads off, and then scribe a line on the saddle from centers, and where the lines cross make a dot with a center punch. If I now put up both main boxes then take a tram and tram from the center on the saddle, will the engine be square? A.—This is not the most accurate way of doing the work. If everything is right it will do, but if the cylinders varied even a very little in the frames, the center you marked off on the saddle might not be in the exact center between the frames, and when you trammed from that point and set the boxes by it, the axle would not be at right angles to the longitudinal center line of the cylinders. The better way is to run your cylinder center lines and use a large square across the pedestal jaws and if the long leg of the square coincides with center line of the cylinders the boxes will be true and the axle will be at right angles to the cylinder center lines. If the square shows that the jaws are out the dead wedge can be altered to suit. In this way the frame does not much matter because you get the axle truly at right angles to the cylinder lines, which is what you want to do.

### BROKEN TRAILING TRUCK EQUALIZER.

(88) Master Mechanic, Longview, Tex., writes:

1. What should be done in case of a broken trailing truck equalizer on a 2-6-2 engine? A.—Such temporary repairs should be made as would prevent excessive weight being put on either pair of wheels. Chain down back end of rear driving spring if it is overhung and chain down forward end of trailing spring if it is over the box. If it is not practicable to chain; block on top of both boxes and block end of equalizer between rear driver and main driver so that the main driving spring would be normal. If one end of the truck equalizer was good and pivot pin all right you might be able to block on top of good end of this equalizer so that either the truck spring or the rear

driving spring would be kept about normal.

### INSIDE LAP AND CLEARANCE.

2. How does inside lap and inside clearance differ on piston valves with inside admission, from others? A.—Under these circumstances there is no difference in principle but there may be differences in amount of each. Inside clearance should be called exhaust clearance because on an inside admission piston valve, the exhaust clearance is necessarily on the ends of the valve and so is the lap which is equivalent to what is called inside lap on an ordinary valve, which is now more accurately spoken of as exhaust lap.

3. Please explain the principal difference of two radically different types of piston valves. A.—You do not state clearly what you want to know in this question. We imagine you mean the two kinds of piston valves which depend on the way the packing rings are held out. In a piston valve with snap rings the rings are out hard all the time, with steam expanded packing rings, the rings fall in a little when engine is drifting and so reduce wear.

4. With direct motion and piston valves with inside admission, what would be the position of the eccentrics when the crank pin is on the forward center? A.—Read article headed, "Wise Eyes are Odd," on page 370 of the August, 1906, issue of RAILWAY AND LOCOMOTIVE ENGINEERING.

### QUICK SERVICE TRIPLE.

(89) E. D. D., Los Angeles, Cal., writes:

If the quick service triple valve takes air out of the train pipe when a service application is made, as is claimed, isn't there greater danger of an emergency application being had than with the old style triple unless the engineer handles the brake valve rather careful? A.—No, not so much. The K triples are so designed that quick action is less likely to be had than it is with the present standard quick action triple valve when a service application is being made. This is because of the difference in design and in location of the ports. On the other hand, when an emergency application is wanted, serial application of the brakes throughout the whole train will be had considerably quicker with the new triples than with the older style.

### PIPING DIAGRAM.

(90) L. D., Nengelo, Holland, writes: I notice a difference between the piping diagram given in an advertisement of the W. A. B. Co. and the one given in the air brake department of the February number. In the first one the supply pipe to the distributing valve branches off between the main feed valve and the brake valve; in the second, between the main reservoir and the feed valve.

Is there any reason that the last arrangement is better than the first? A.—Yes. When the supply pipe branched off from the pipe between the brake valve and the feed valve, air for the brake cylinders had to come through the feed valve, and because of the restricted opening in this valve and of the further fact that the initial pressure was not so high as that of the main reservoir, the brake cylinder pressure did not equalize so quickly as was desirable. There was also the possibility that if the feed valve was defective from any cause it might remain closed at the critical moment, and no air would then be supplied to the brake cylinders in case an application was desired. Hence the supply pipe was coupled to the main reservoir return pipe direct, where none of the foregoing objections existed.

### INDEPENDENT INLET.

(91) R. L. C., San Francisco, asks:

What is the use, or advantage, of the independent inlet valve on the high pressure cylinder of a New York No. 5 pump? A.—When working fast, the independent air inlet valve admits atmospheric air to the high pressure air cylinder, thus increasing considerably the capacity of the pump. At slow speeds, there is no marked advantage had by the use of the independent air valve.

### INJECTOR COMBINING TUBE.

(92) M. J. A., Meridian, Mass., writes: Will you kindly tell why holes are sometimes drilled in the combining tube of an injector? A.—The holes you refer to are put there in order to be a sort of auxiliary overflow to lessen the shock which takes place when a rapidly moving steam jet strikes and combines with the slow moving body of water. The water forced out of these holes eventually passes out of the main overflow. The presence of the holes also enables the injector to work with water, a few degrees higher in temperature than if the holes were not there, but the principal reason the holes are there is to lessen the shock in the instrument.

### HOW MUCH PAY?

(93) R. L. C., San Francisco, asks: What is the average salary paid to a first-class locomotive draftsman? A.—Railroads usually pay something between \$85 and \$100 per month, but the amount is subject to variation in parts of the country where living is high and for other reasons.

### COATING ON FLUE SHEET.

(94) W. L., Brownville, Mo., writes: Please inform me as to the cause of the flues of my engine "honeycombing" at the end of a run of 76 miles. The flues and flue sheet will be a solid mass of collected cinders. Tell me what can be done to prevent it. The engine is an H. 6. a. type, in freight service, and

the coal is good on our division. A.—This is caused by some impurity in the coal, probably a silicate of soda, which is a very refractory substance. Its cohesion may be destroyed by charging freely with lime with the coal. When lime is present the tubes do not fur up or honeycomb. The lime combines with the silicon and sets free the soda.

#### THE "K" FEED VALVE.

(95) D. C. R., East Rochester, N. Y., writes:

I noticed in the E T pamphlet, sent out by the W. A. B. Co., that the K feed valve, shown as a part of the new brake in the article illustrating it in the February number, is not given, but another like the G6 except for an adjusting handle on the end of it, is shown instead. Has the K feed valve been discontinued, and if so, why? A.—The B4 feed valve supersedes the K feed valve in steam road service for several reasons; among these was the trouble experienced from dirt and scale from the piping, which caused it to work unsatisfactorily, and there was the further reason that the opening through it was so large that, if the locomotive was equipped with a large air pump and had a large main reservoir, it was more difficult to handle brakes properly with the back-up hose, unless the brake valve was lapped. There was also under these conditions, and with long passenger trains, a doubt as to whether quick action of the brakes could be obtained if the conductor's valve was opened on any one of the cars that were close to the engine. On account of the large main reservoirs and the large pumps now ordinarily applied to locomotives in passenger service, the opening through the feed valve must not be enlarged, if it is desired to operate brakes from the back-up hose satisfactorily, or when long passenger trains are being hauled, to make sure that the brakes can be applied in quick action from any conductor's valve in the train; hence the change.

#### RELEASE ON LONG TRAINS.

(96) J. R. S., Scranton, Pa., writes: Please settle an argument for us. My partner claims that the brakes can be released on a train of any length just as easily with the new New York brake as with the old, while I claim they can't. What say you? A.—As we understand the new New York engine brake, having a pressure controller between the main reservoir and the brake valve to regulate brake pipe pressure, the full effect of the main reservoir excess pressure is not had when the brake valve handle is thrown to release. Therefore, on long trains, it would seem that release of the brakes would not be so prompt and uniform as it would with the older equipment. The recharging of the auxiliaries

will also be affected in that the recharge will be slower. We think you are right in your claims.

2. Which will reduce the pressure the quickest in the rear end of a long train in a service application, the quick service K triples or the New York accelerator valve? A.—The quick service K triples will reduce the pressure in about one-half the time required by the New York accelerator on a train of any ordinary length. On extremely long trains the advantage is all with the K triple, since it does not have appreciable brake pipe friction to contend with.

#### SERVICE REDUCTION WITH 80 CARS.

(97) F. B. K., Ogen, Utah, writes:

When handling trains of eighty or more cars, all with present style quick action brakes, the instruction is to make the first service reduction seven or more pounds in order to get all the brakes on, even heavier than this would in many cases be better. If all cars had the quick K triple valves, would this same rule be necessary? A.—No; if all the cars in the train have the K triples a 5 lb. service reduction will set the brake on them all uniformly, whether the train consists of one, or one hundred or more cars. Each quick service triple acts in a manner as a straight air brake valve for its own brake cylinder, thus avoiding in a large degree the resistance to the flow of air in the brake pipe, caused by friction, and at the same time they economize very largely in the quantity of air used in making the application. If the train is but partially equipped with K triples the action of the older style triples is much improved.

#### PINS NOT IN TRAM.

(98) C. R. W., Caryville, Fla., writes: If all the centers of the driving wheels tram the same and the pins are out on one side say  $\frac{1}{8}$  of an in., how would you divide the distance so as to make things right? A.—If the wheels are all properly in tram and the pins out, you had better not try to divide the error or fix it up. Ascertain the cause of the pins being out, as one pin might be farther from the center than the other, or a pin might be bent, and in either case you could not get the side rods to run properly.

#### N. Y. BRAKE ON TENDER.

(99) C. P. H., East Buffalo, N. Y., writes:

On a tender which has a New York quick action triple we had trouble on account of a leak at the vent port, when the brake was set with a service application. The brake would stay on all right, but all the train pipe air would escape. The brake would not set quick when emergency was made. What was the matter? A.—The causes of troubles of this kind can best be determined by a careful inspection of the internal parts

of the defective triple. Causes have come to our notice where a diagonal break in the vent valve stem, through the large part of the axial port, has produced the effects you mention.

The broken stem turning around had the effect of lengthening it, so that in service applications it would force the vent valve partly from its seat and cause a blow at the vent port, until brake pipe air had entirely escaped or the brake was released.

The break in the stem occurring in the large part of the axial port prevented the cushioning of the air between the pistons, and so destroyed the quick action feature of the triple.

#### James Dredge.

The engineering world has lost an able and accomplished writer by the death of James Dredge, for many years connected with the staff of Engineering, of London, England. Mr. Dredge was well known among the leading railway men in America, having visited this country three times. In 1876, during his visit to the Centennial Exhibition, he collected materials for a series of able articles on the Pennsylvania Railroad, which were published in book form. In 1890 he visited New York and delivered an address on the unveiling of a statue erected to the memory of Alexander Holley. Again, at the special request of the American Society of Mechanical Engineers, he contributed a memoir of the late Sir Henry Bessemer, which was presented at the meeting at Niagara Falls in 1898.

Mr. Dredge was born at Bath in 1840 and studied civil engineering in London. He made the drawings for D. K. Clark's book, "Recent Practice in Locomotive Running." It was at this time, in 1861, that Mr. Dredge made the acquaintance of the late Mr. Zera Colburn, the eminent American engineer, who was for a long time editor of The Engineer, of London, and who subsequently started Engineering, where Mr. Dredge took charge of the illustrations. It is no disparagement to other engineering journals to say that Mr. Dredge's work on Engineering has been the high water mark of mechanical illustrations for over forty years, while his ability as a writer was nearly equal to his faculty as an illustrator.

In his social life Mr. Dredge was a delightful companion. He was a fine specimen of the English gentleman. He had learning without pedantry, and eloquence without ostentation. He was appointed on many important British commissions to exhibitions in foreign countries. He was an officer of the Legion of Honor of France and a Companion of the Order of St. Michael and St. George in Great Britain.



# Air Brake Department

CONDUCTED BY J. P. KELLY

## Obstruction in Brake Pipe.

A remarkable case of failure of brakes to apply when tested, after coupling up and charging, came to light a few weeks ago on one of the large lines between Buffalo and New York. It appears that a few weeks previous to the failure noted, this road had delivered to it a consignment of brand new cars, and they had been in service long enough to get well mixed with the older equipment, and to have the air brakes operated on them many times. Up to the time of the failure to apply, nothing unusual had been observed about the action of the brakes on these cars, but when this particular test was made it was found that the brake would not apply back of a certain car of the new lot, which happened to be located within a few car lengths of the engine.

As all angle cocks and stop cocks were wide open and all auxiliaries in the train found charged, a rigid investigation was instigated to reveal the cause of failure, and the following was the result: a punching, about  $1\frac{1}{4}$  ins. in diameter, was found lodged in the pipe in such a position that it practically closed up the passage. This punching being similar in size and shape to many others frequently found lying around the floors of car works, it is inferred that, in some way, while the piping was being prepared one of them accidentally lodged in the end, and worked into the pipe far enough to escape notice, and then worked around inside the pipe until it prevented the brake application.

## Possible Troubles and Their Remedies.

The following are some of the troubles that may happen to the E T equipment, and their remedies:

If the brake pipe connection to the distributing valve breaks off close to this valve, close the cut-out cock in the cross-over pipe; if broken at the brake pipe tee, plug this tee, and brake with the automatic (H S) brake valve to apply the train brakes, and with the independent (S F) brake valve to apply the locomotive brakes.

If the small double cock (A B V) brake valve pipe is broken off at the distributing valve you can still use the automatic or the straight air brake valve to do the braking on the train and the engine; but if the independent brake valve connection is broken off at the distributing valve you cannot set the brakes on the engine either with the

automatic or the independent brake valve. This would not, however, interfere with the train braking. If the supply pipe is broken off, plug it near the feed valve connection; then brakes cannot be used on the locomotive, as this pipe supplies all the air for the engine and the tender brake cylinders. If both automatic and independent pipe connections to the distributing valve are broken off, do not stop to plug them, as you could not use the brakes on the locomotive because of inability to build up pressure in the application chamber.

brakes, since it will all escape at the automatic brake valve.

When making a 5 lb. service application and the automatic brake valve handle is returned to lap position, you notice pressure building up in the brake cylinder, it is an indication of a bad leak either in the brake pipe or in the lower slide valve of the distributing valve. A leak in the brake pipe will be indicated by the falling of the black pointer of the duplex gauge; a leak through the lower slide valve will be indicated by the increase of cylinder pressure only.



PARTY OF AIR BRAKE DELEGATES RETURNING FROM MOUNT ROYAL, AIR BRAKE CONVENTION, MONTREAL, CANADA.

If you have any trouble with the K feed valve, unscrew the cap and take out vent valve 28 and clean it. The satisfactory operation of the K feed valve depends on the cleanly condition of vent valve 28, which usually stops up where the round end projects through the vent valve hole back of the seat.

I have filed off the side of the round part, making it triangular. This allows the air to flow more freely, and prevents clogging up, and I have had no trouble with them since. It is not necessary before removing vent valve 28 to shut off the air, since the opening through the piston is very small and but little air can escape.

If there is a blow through the automatic brake valve, do not report brake valve cleaned, but have the distributing valve examined, as a leak in the lower slide valve of the equalizing valve will permit air to flow to the application chamber although not enough to set the

To distinguish between a leak through the rotary of the independent brake valve and one through the lower slide valve of the equalizing valve, disconnect the pipe leading from the distributing valve to the independent brake valve at the connection to the latter. If the rotary leaks, air will blow down from the valve; if the slide valve leaks, air will blow out of the pipe. After determining which is leaking make proper repairs.

When making an application, either automatic or straight air, the brakes do not remain applied, look for leaks in the pipe connections between the brake valves and the distributing valves.

If you cannot get an automatic application of the brakes, and pipe connections do not leak, take out the equalizing (lower) piston to see if ring is stuck or the small hole through the end of the slide valve, next to the piston, is stopped up. If either, apply the proper remedy, but be careful not to en-

large the hole in the slide valve, as the pressure chamber would then charge up too fast.

If neither an automatic or an independent application of the brakes can be obtained, remove the cap over the application slide valve (5) to see if pin is broken. If the pin is broken, the application valve cannot be moved. If the pin should break, leaving the application valve in open position, the brakes will remain set as long as the pump runs.

If a brake beam breaks on the engine, close the cut-out cock in pipe to the driver brake cylinders; if the tender brake is out of order, close cut-out cock in pipe to the tender brake cylinder. If there are no cut-out cocks in the brake cylinder pipes, as was the case on some of the first engines we received, then carry the independent brake valve in release position. We have since, however, placed the cut-out cocks in the brake cylinder pipes.

The safety valve should be kept in good condition in order that it may properly relieve the brake cylinders of surplus pressure.

When the equalizing piston and slide valve are in service position, communication between the application chamber and the safety valve is established, and this valve will commence to blow when the cylinder pressure reaches 53 lbs., which is the amount for which it is set. More pressure than this in the brake cylinders, ordinarily, is likely to slide wheels.

If the safety valve is in good condition air will blow out of the two top holes in the body when slightly relieving the application chamber, and out of the six lower ones when freely and quickly relieving it. In the latter case brake cylinder pressure forces application piston back until it opens the exhaust valve and allows the surplus cylinder pressure to escape.

It will be easily seen that the safety valve has only to control the application chamber pressure in order to regulate the brake cylinder pressure.

In the emergency application of the brakes the safety valve should hold 60 lbs. in the brake cylinder for about 20 seconds, then should pop off pressure in chamber *g* and the application chamber so as to reduce the brake cylinder pressure to 53 lbs. and prevent wheel sliding.

There are some roads that cut down the pressures to 40 lbs. for the automatic and 30 lbs. for the straight air application, but we still maintain 53 lbs. for the automatic and 45 lbs. for the straight air, and thus far we have experienced no trouble with slid-flat wheels.

We maintain the driver brake piston travel at 4 ins., standing, which will increase to 5 or 5½ running, and on the

tenders at 6 ins. This travel we find to be entirely satisfactory.

ASA R. HAY,  
Air Brake Inspector, Big Four R. R.  
Indianapolis, Ind.

#### Transposed.

Through an unfortunate oversight the diagrams shown in Figs. 2 and 5 of the September number, Air Brake Department, got mixed; Fig. 2 should appear as Fig. 5, and Fig. 5 as Fig. 2. The drawing showing the actual construction of the slide and graduating valve,

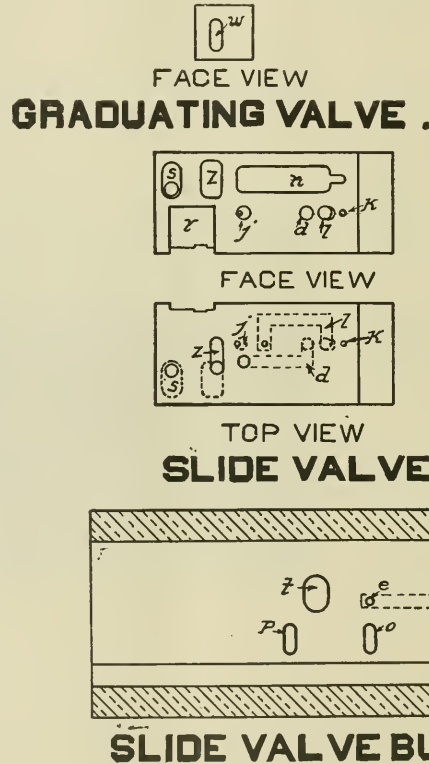

FIG. 7. ARRANGEMENT OF PORTS AND CAVITIES IN "K" TRIPLE VALVE. SEE PAGE 423, SEPTEMBER ISSUE.

Fig. 7, was entirely omitted, but is here produced for the benefit of our readers.

The North British Railway locomotive that went down with the ill-fated Tay bridge in 1879, and remained three months embedded in the channel of the river, still runs important goods trains.—N. Y. Globe.

The most powerful locomotive in Britain has just been built at the St. Rollox workshops of the Caledonian Railway. It weighs 130 tons, and will run the London expresses between Glasgow and Carlisle.—N. Y. Globe.

#### Oil Burners in Mexico.

Not long ago the Mexican Central received some new engines adapted for the burning of oil. They were built by the American Locomotive Company. The work of installing the oil storage system has been carried on vigorously and supply tanks have been placed on all divisions where these engines will be used. The Mexican Central Company believe that they will be able to effect substantial economy in the locomotive department by the use of oil as fuel. Coal in Mexico is an expensive item, as there is not much of it found in that country and large quantities have to be imported from the United States. The full economy of operation will not come at once, as the men are used to coal and have to become familiar with the new conditions, but it is anticipated that the ultimate gain will be very satisfactory.

It is only eight years since a deputation from the Belgian State Railways visited Britain in search of the best type of locomotive for working their fast international expresses, and already throughout Belgium there are at work several hundreds of engines that could scarcely be detected from those of the Caledonian Railway. They were designed by

Mr. McIntosh, the mechanical engineer of the latter company, at the request of the Belgian government.—N. Y. Globe.

#### Should Do Better.

In a railway carriage the other day a traveler overheard an Englishman and a Scotsman discussing the character of the Irish people. Said the Englishman: "Well, I rather like the Irish. I think they have many good points."

"Weel, a' doon't deny it," replied the Scot, "but ye ken they canna speak English wi'oot a brogue. Their axunt's maist awfu'!"—World Wide.

**Patent Office Department.**

It will be observed that the inventors are particularly busy on the smaller details of boiler construction. Some of their devices are very clever and we reproduce some of them with accompanying illustrations. Our descriptions are necessarily brief, but our readers who desire fuller details can readily secure the same by applying to the Patent Office authorities at Washington and state the number of the patented article which we append to our short descriptions, and the printed details and large sized illustrations will be furnished on application.

**BRASS FOR JOURNAL BOXES.**

Mr. J. S. Patten, Baltimore, Md., has patented a brass for journal boxes, No.

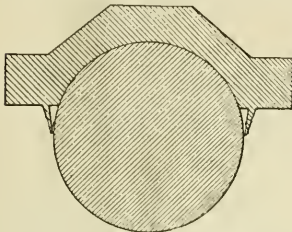

NEW FORM OF JOURNAL BEARING.

829,170. The brass has a dependable flange at each side of the bearing face, a wall at each end of the flange, the space between the walls being divided into compartments, the dependable flange forming a concavity and gradually and continuously approaching the journal, the upper edge of the flange being spaced from the curvature of the concavity of the brass, each of the flanges extending from end to end of the brass and terminating at a wall disposed to prevent the flow of oil from off the end of the flange.

**PISTON PACKING.**

Mr. L. H. Martell, Ellwood City, Pa., has secured a patent for an improved

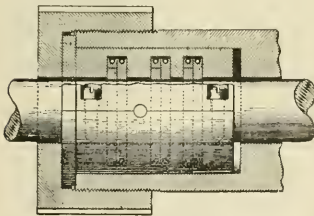

PISTON ROD PACKING.

packing for piston rods, No. 829,116. The device consists of a cage or case for packing rings provided with grooves in its interior wall, and metal packing rings arranged in the grooves. The cage is provided with a peripheral flange projecting over the end of the box, and a gland for clamping the flange on to the stuffing box.

**ENGINE TRUCK.**

Mr. T. E. Adams, Pine Bluff, Ark., has secured a patent for an engine truck, No. 830,274. The truck consists of cast steel side frames with solid pedestals, and a frame for a swinging

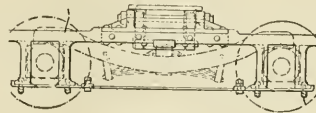

ENGINE TRUCK.

center bearing consisting of continuous end members which rest on the upper edges of the side frames, lugs being attached to the side frames and engaging the ends of the continuous end members, and fastening devices connecting depending flanges to the side frames.

**GAUGE COCK.**

A gauge cock has been patented by Mr. J. T. Cullison, Columbus, Ohio, No. 829,632. The device comprises a casing section having a bore formed throughout, the forward portion of which is reduced, and a spring actuated valve slidably disposed in the bore, and furnished with longitudinal channels for the passage of steam or water, and a valve

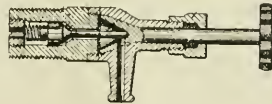

GAUGE COCK.

stem projecting from the valve through the reduced portion of the bore and a detachable casing section. A valve is located in the casing section and adapted to bear against the end of the valve stem when the section casing is screwed into place. The contrivance has the merit of being free from leakage at the valve stem.

**BOILER SCRAPER.**

Mr. Frank Ludwig, Montrose, Col., has patented a boiler scraper or cleaner, No. 829,024. The device embraces the combination of a hand plate adapted to be secured in the hand hole of a boiler, a valve seat in the hand plate, a

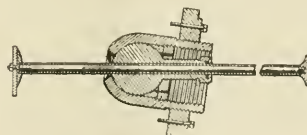

BOILER SCRAPER.

ball valve within the valve seat, a rod adapted to operate through the ball valve, a locking valve seat through which the rod passes into the boiler, the opening within the valve seat being of a

size to allow the rod a free vertical or lateral motion. Means for scraping the boiler are attached to the inner end of the rod.

**CROSS-HEAD.**

A very substantial device combining a cross-head and piston rod has been patented by Mr. J. B. Kingan, Schenectady, N. Y., No. 830,080. It consists of a piston rod portion and a cross-head portion made solid by forging or welding, the cross-head piece having an opening for receiving the end of a con-

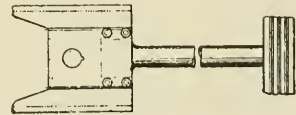

CROSS-HEAD AND PISTON ROD.

necting rod, a portion of the jaws of the opening serving as flanges to receive wearing shoes; the end portion of the piston rod being made to secure the rod to the piston.

**BOILER FLUE.**

A boiler flue has been patented by Mr. J. M. Crozier, Minneapolis, Minn., No. 829,509. In combination with laterally spaced flue sheets having tapered flue seats, the flue has at one end a fixed conical sleeve portion, and at the other end a screw threaded conical portion, both ends having the same diameter and taper as the flue seats. Annular packing rings of soft material are interposed

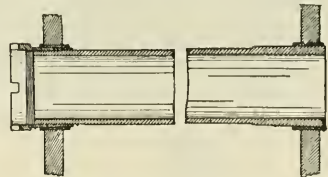

BOILER TUBE SETTING.

between the sleeve portions and the surrounding seats.

**Demonstration Demanded.**

A Scotsman went to London for a holiday. Walking along one of the streets he noticed a bald-headed chemist standing at his shop door, and inquired if he had any hair restorer. "Yes, sir," said the chemist; "step inside, please. There's an article I can recommend. I've testimonials from great men who have used it. It makes the hair grow in twenty-four hours." "Aweel," said the Scot, "ye can gie the top o' yer heed a rub wi' it, and I'll look back the morn and see if ye're telling the truth." The chemist returned the bottle on the shelf with disgust, and kicked the errand boy for laughing.

### Baldwin Mallet Compound.

Our illustrations represent one of five Mallet articulated compound locomotives, recently built by the Baldwin Locomotive Works for the Great Northern Railway Line. These engines are the heaviest thus far constructed in the Baldwin Works. They are intended for freight service, and are designed to pass round  $10^\circ$  curves. The tractive power when engine is working com-

wheels under this engine. The high pressure cylinders which drive the rear group of wheels are cast separately from their saddle, which is bolted to the upper frame rails. The low pressure cylinder castings meet on the center line of the engine and are bolted together. The steam pipe connection between the high and low pressure cylinders has a ball joint at the rear end and a slip joint with a packed gland at

pressure steam chests. There is, therefore, no dry pipe in the usual sense of the word. The throttle valve is intended to permit a small amount of steam to reach the cylinders when the engine is drifting. It was designed and patented by Mr. Kenneth Rushton, chief draughtsman of the Baldwin Locomotive Works. There was an account of the Rushton throttle valve published in RAILWAY AND LOCOMOTIVE ENGINEERING in August,

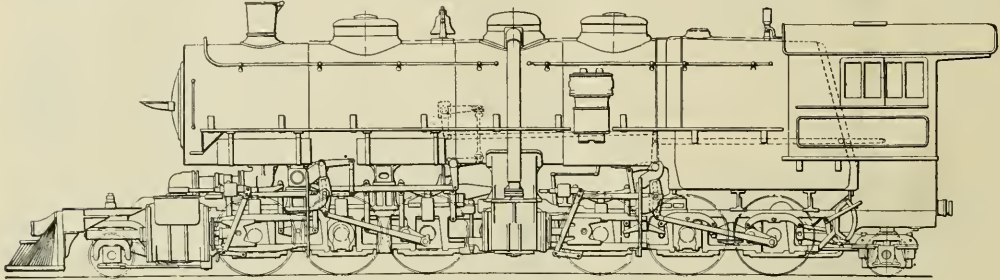

SIDE ELEVATION OF BALDWIN MALLETT ARTICULATED COMPOUND ENGINE.

pond is 71,600 lbs. and the factor of adhesion is 4.41.

These locomotives are provided with two wheel front and two wheel rear trucks, which are equalized with the front and rear groups of driving wheels respectively. The front truck has a center bearing while the rear truck has side bearings. This arrangement is intended to reduce flange wear on the driving wheels and enable the engines to curve readily and ride smoothly.

The word articulated is used in describing engines of this class and it refers to the fact that the front group of driving wheels and the main frame of the engine are able to turn on a

the front end. The exhaust connection between the low pressure cylinder and smoke box has a ball joint at each end and a slip joint in the middle. This has the effect of allowing the frame, engine truck, and front group of driving wheels, to swing radially under the boiler and at the same time, the joints are kept tight, expansion and contraction of the steam pipes is provided for, and the exhaust pipe is always in line with the smokestack. Observe the flexible coil of oil pipe from smoke box to low pressure steam chest, shown in the half-tone illustration.

The frames are of cast steel and measure 5 ins. in width throughout. The

1903, on page 358. The valve there represented was slightly different in detail to the one used in this Mallet engine, but the principle is the same. This one is designed so that it may be opened very slightly when the engine is drifting and thereby supply a little steam to the cylinders, just enough, in fact, to carry the lubricant in and prevent the smoke box gases from destroying the effects of lubrication.

The throttle valve is hollow and it is therefore always full of steam, and is consequently as hot, and as much expanded, as the case. When it is opened, steam enters only through the top, which insures its always receiving the

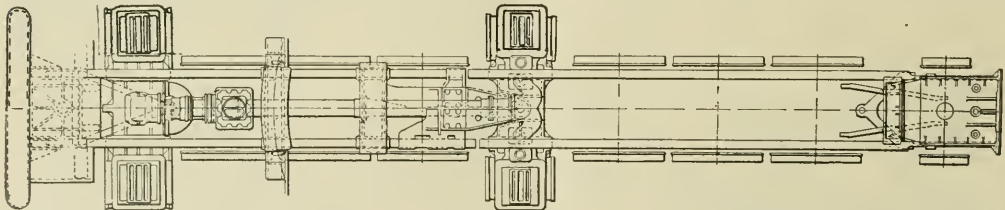

PLAN OF BALDWIN MALLETT COMPOUND ENGINE FOR THE GREAT NORTHERN.

joint which is situated under the boiler and below the saddle casting of the rear pair of driving wheels.

The cylinders of this engine are  $21\frac{1}{2}$  and 33 by 32 ins. and all four cylinders are provided with balanced slide valves driven by Walschaerts valve gear. The McCarroll air reversing mechanism is used. The driving wheels, of which there are twelve pair, are 55 ins. outside diameter. The engine truck and the rear truck wheels are all 30 ins. in diameter and altogether there are 28

rear frames have double front rails cast in one piece with the main sections. The front frames have separate top rails, which pass over the low pressure cylinder castings. They are strongly braced transversely by heavy castings, which serve at the same time as boiler supports. The saddle under the smoke box is provided with coil springs, which help to bring the front group of wheels in line after rounding a curve. The branch pipes are outside and pass from the sides of the dome direct to the high

dryest steam there is. The bottom of the valve is a disc and above it there is a circular port in which there are several stiffening ribs.

The throttle mechanism is designed with a view of securing a very fine opening when desired. In fact with this rig you can just "crack" the valve, as engineers say, and the way it is done is by using a sort of double lever to open the valve. Fig. 1 is a side view of the throttle and the opening mechanism, and Fig. 2 is a cross section. The

throttle stem terminates in a wide flat piece, something like one end of a dumb-bell in shape, and in it are two slot holes one up and the other down, layed off radially with the pivot pin as the center. One has  $2\frac{3}{4}$  in. radius and the other  $5\frac{1}{4}$  in. radius. The bell crank has the vertical arm 11 ins. long and the upper part is broadened out so as to take in the pivot pin, which is in the angle of the bell crank, and the two slot holes. The bell crank carries two studs, one of which works in each slot hole. The slot holes are so placed that the stud near the pivot pin, the one at the short radius, begins to lift first, and as the leverage is more than three and a half times in favor of the vertical arm, it follows that a comparatively long movement of the throttle rod will give only a small movement of the valve and the greatest leverage is exerted when the valve has no pressure to balance it.

prevents the inner stud from doing any further lifting. The studs and slots are so arranged that both studs do not lift at the same time. The short radius one lifts little and slowly at first, and when it gets in its work the long radius stud goes on with the business and raises the valve faster and through a greater distance.

Another interesting feature of this compound is the reversing mechanism. It is an air operated screw machine and the real reverse lever of this huge engine is no bigger than an engineer's air brake handle. The device was designed and patented by Mr. W. J. McCarroll. It was illustrated and described on page 326 of the July, 1905, issue of RAILWAY AND LOCOMOTIVE ENGINEERING.

In order to operate the McCarroll Reversing Mechanism, air is admitted to its four horizontal cylinders through

links reach full gear, the reverse lever or small handle being moved by one of the little eccentrics located at either end of the quadrant. The reach rod is moved by means of bevel and worm gears and this permits of the valve travel being cut up finer than can be done with even small notches on an ordinary reverse lever quadrant. The hand wheel is to be used in cases of emergency, or when no air supply is available, so that the engine links can be moved at all times.

The boiler is of the Belpaire type, with straight throat sheet and sloping back head. The waist is built up of three rings and is 84 ins. in diameter at the front end. The circumferential seam in front of the dome is triple riveted, and the others are double riveted. The horizontal seams have diamond welt strips. The water spaces are un-

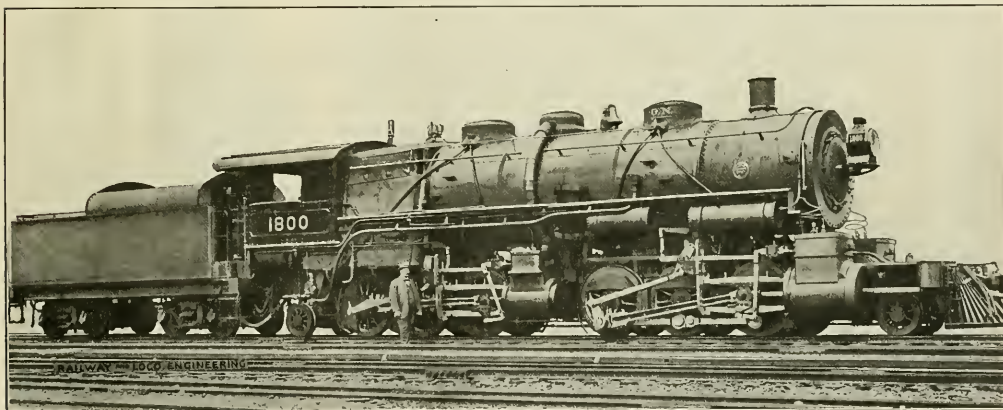

MALLET ARTICULATED COMPOUND FOR THE GREAT NORTHERN.

G. H. Emerson, Superintendent of Motive Power.

Baldwin Locomotive Works, Builders.

All throttle rigging has a certain amount of lost motion in it, put there intentionally, so that the valve when shut will not bear upon or be bound in any way by bolts or levers, but even allowing for this, it is possible with this arrangement to get a very much finer opening of this throttle valve than is usual in the majority of engines.

When it is desired to open this throttle further, for regular service the action of the bell crank produces a wider and quicker action as it is moved further. While the short radius stud is opening the valve slowly, the stud at the longer radius is swinging through its slotted hole and soon comes to the end of it, and begins to lift the valve. As its leverage is just a little over two to one, it lifts the valve quickly and fully and the inflowing steam tends to balance the valve, while the slot hole for the short radius stud

a rotating valve, mounted directly on the shaft. The admission of air is controlled by a slide valve moved by the operating handle. The handle is held in position by a controlling catch and spring. When the handle is moved forward, "live" air enters the central opening in the rotating valve, and the little air engine is put in motion. When the handle is moved to its backward position, "live" air is admitted to the outside part of the rotating valve, and the air engine is reversed. The pointer remains stationary while the quadrant is rotated by means of a connection with the reverse lever rod.

In order to stop the reversing mechanism, the operating handle is moved to its central position, and this allows for the main valves of the big engine cutting off at any point in the stroke. If the handle is not moved, the device will be stopped automatically when the

usually wide, while the tubes are spaced with  $\frac{3}{4}$  in. bridges.

The dome is made of cast steel, and the ends of the branch pipes are cast with it, having an outlet on each side. Steam is conveyed to the external pipes through short connecting pipes, which are cast in one piece with the dome.

The heating surface is made up of 225 sq. ft. in the fire box, 5,433 in the tubes, making a total of 5,658 sq. ft., and the grate area is 78 sq. ft., giving a ratio of grate to heating surface as 1 to 72.4. The tubes are made of steel  $2\frac{1}{4}$  ins. outside diameter, 21 ft. long and there are 441 of them. The boiler pressure carried is 200 lbs. per square inch.

The total weights on the driving wheels are estimated at 316,000 lbs.; on leading truck 19,000 and on trailing truck 20,000 lbs. The wheel base is 10 ft. long for each group of drivers and 44

ft. 10 ins. for the whole engine. With tender, the total wheel base is 73 ft. 2 1/4 ins. The total weight of the engine is 355,000 lbs. and with the tender everything being in working order, the weight is 503,000 lbs. There is shown

weighs, without tender, 344,500 lbs. It has twelve driving wheels 56 ins. in diameter and a tractive power of 74,000 lbs. when working compound and 84,000 lbs. when working simple. Ratio of tractive power (compound) to

Fire Box—Material, steel; length, 117 ins.; width, 96 ins.; depth, front, 79 1/2 ins.; back, 76 1/2 ins.; thickness of sheets, sides, 3/8 in.; back, 3/4 in.; crown, 3/4 in.; tube, 1/2 in.; water space, front, 6 ins.; sides, 5 ins.; back, 5 ins.  
 Tubes—Wire gauge, No. 11.  
 Driving Wheels—Journals, 10x12 ins.  
 Engine Truck—Journals, front and back, 6x12 ins.  
 Tender—Wheels, diameter, 36 ins.; journals, 5 1/2 x 10 ins.  
 Service—Freight.

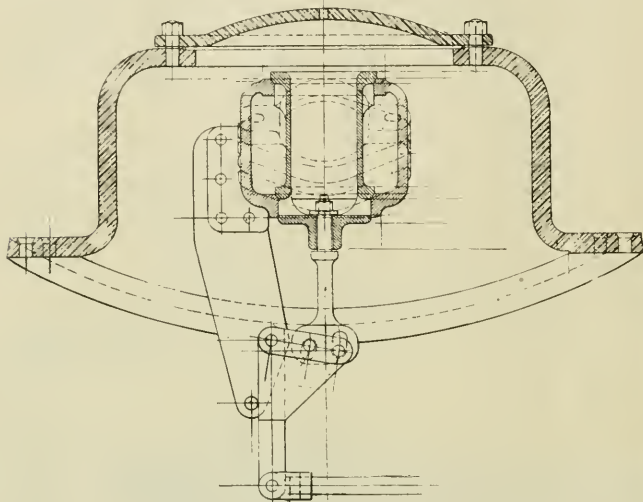

SIDE VIEW 'RUSHTON DRIFTING THROTTLE VALVE.

on our side elevation line drawing a bracket on the back of the smokestack, which is a hinge for a smoke deflector to be used when the engine is passing through tunnels.

The tender has a steel frame and the

adhesive weight is as 1 is to 4.65. The cylinders are 32 and 20x32 ins. and the boiler pressure is 235 lbs. Heating surface 4,325 sq. ft.; grate area 56.1 sq. ft. This engine was described and illustrated on page 283 of the June, 1904.

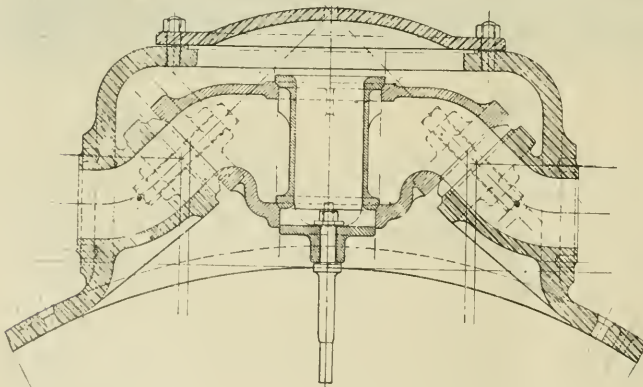

CROSS SECTION OF THROTTLE AND DOME SHOWING BRANCH PIPE JOINTS

tank has a water capacity of 8,000 U. S. gallons and 13 tons of coal.

In this connection it may be interesting to compare with this engine the Mallet Articulated locomotive built some years ago for the Baltimore & Ohio Railroad by the American Locomotive Company. The B. & O. engine

issue of RAILWAY AND LOCOMOTIVE ENGINEERING.

Some of the principal dimensions of the Baldwin Mallet Compound for the Great Northern are as follows:

Boiler—Thickness of sheets, 3/8 in.; working pressure, 200 lbs.; fuel, soft coal; staying, vertical crown stays, 1 1/4 ins. dia.

Traveling Engineers' Association.

(Continued from page 458.)

exercise and those who have not acquired the habit of intemperance or excessive cigarette smoking. The maximum age limit is drawn at twenty-eight years. Those who after leaving school have been an apprentice, laborer or helper in a machine shop or roundhouse,

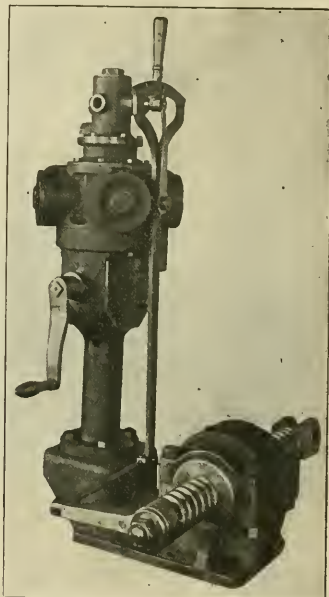

AIR OPERATED REVERSING MECHANISM, MALLETT COMPOUND.

or watchman of an engine, are considered good material, their experience in such service enabling them to perform the duties of fireman.

The scholar with a training on mechanical and technical subjects is still better equipped.

More attention should be given the younger element, both firemen and engineers, immediately after their employment and promotion in the way of the master mechanic, road foreman of engines, roundhouse foreman and engineers lending their assistance to start the young man right. Care on the part of the management is essential to prevent overloading the road foreman of engines with a large number of engines

and great mileage to cover, as such precludes him from properly instructing all the new men as how best to perform their duties and render the best service for the employers' interests. Starting right is the watchword, for the fireman is the future engineer and the employment of traveling firemen is a right step in this direction.

The practice too often prevailing, to criticize the young engineer who fails to duplicate the work of his more experienced brother was deprecated.

Regarding both firemen and engineers, the committee suggests how these men should be cared for at terminals with a view of improving their mental and social standing. Good, clean rest rooms should be provided and cleanliness encouraged.

Access to reading rooms or libraries to be had where they can keep informed on the leading topics of the day, mechanical and otherwise, and the Young Men's Christian Association is heartily recommended as a most potent means of improving the standard of the men, from a moral as well as social standpoint.

In conclusion, the committee believes the road foremen of engines have not done all they should in starting the young man right and encouraging him to seek advice, the paper urging all to adopt such practice. The paper was so complete in its treatment of the subject that it was received with little discussion, the thanks of the convention being tendered with the injunction for everyone to take the paper home and give it the consideration it deserved.

MR. O. R. REHMEYER'S PAPER.

The seventh paper was entitled "The Walschaerts Valve Gear." The paper points out and discusses the gear as follows: It was invented in 1844 and has been for a number of years in service on foreign roads. Its introduction into America was principally on account of the increase in size of motive power. Its advantages are less weight than the Stephenson, resulting in less wear to its connections and less liability of breakdowns.

The valve motion is direct, with a constant lead at all points of cut-off, this lead being an advantage, as with large cylinders it is difficult to obtain sufficient lead with the link motion at long points of cut-off, at the same time keeping down pre-admission and excessive compression at short points of cut-off. Constant lead in connection with large cylinders gives an amount of lead at long cut-off to properly cushion the reciprocating parts and reduces pre-admission and compression at short cut-off, thus making a more pre-working and easier running engine, saves steam and reduces pounding of the bearings

of heavy engines carrying a high steam pressure.

From an inspector's standpoint, this gear is far superior to any other valve motion in use, all parts liable to develop defects being in plain view and easily examined from the outside.

As the Walschaerts valve gear has been in service in this country a short time only, opinions regarding it are difficult to get; therefore, the chairman of the committee gives his personal observation and experience. The cost of maintenance of the Walschaerts are compared to the Stephenson is believed to

ped with the Stephenson make better time on the level or on favorable grades, but where the grade is against them, engines with the Walschaerts gear makes the best time, each handling the same tonnage. The valves on these engines having the Stephenson gear have  $\frac{3}{8}$  of an inch lead at full stroke, with 1 in. lap. With the Walschaerts valve motion several of the engines have  $\frac{3}{4}$  of an inch constant lead and  $\frac{7}{8}$  in. lap; the others,  $\frac{5}{8}$  in. lead and  $15/16$  in. lap. In the discussion following the reading of the paper these additional points were presented. Reports from a number of

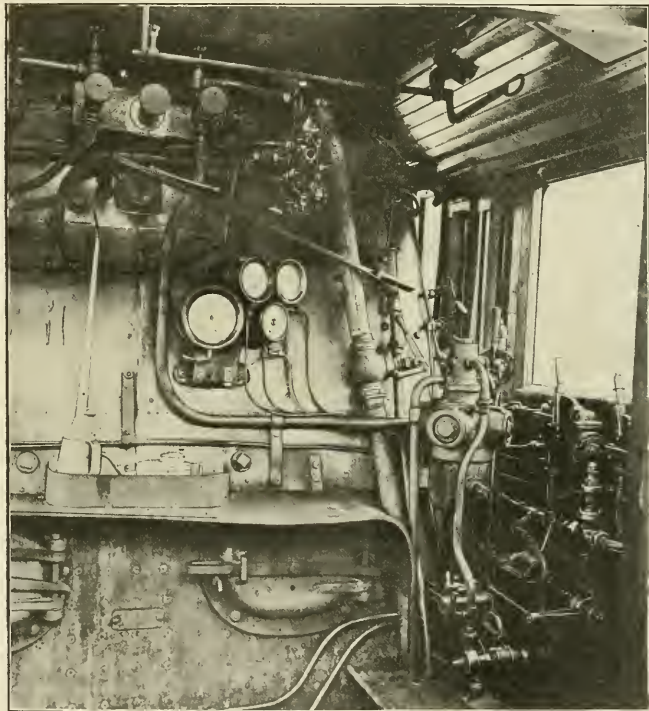

INTERIOR OF CAB OF BALDWIN MALLETT ARTICULATED LOCOMOTIVE SHOWING REVERSING MECHANISM.

be 25 per cent. in favor of the first mentioned; engine failures due to valve gear 33 per cent. less. The Walschaerts link has less rocking movement than the other, giving a more favorable action on the link block, with less tendency to spring the gear at and near the extremity of its stroke and the up and down motion of the link noticeable with the Stephenson motion is dispensed with.

Regarding the advantages of one gear over the other for speed, the paper is non-committal, though the consensus of opinion of engineers handling the two types of gear on engines otherwise alike, all in freight service, is that those equip-

roads indicated that engines with the Walschaerts gear were giving satisfactory service; valves were less liable to get out of square, less valve leakage, and no marked difference in coal consumption between the two types of gear.

#### POOLED ENGINES.

The eighth paper was headed, "Regularly Assigned vs. Pooled Engines: The Relative Merits and Demerits of the Systems of Handling Each." The committee from a traveling engineer's standpoint, feel safe in saying that regularly assigned engines would be the unanimous choice, as it is generally admitted such engines are kept in better condi-

tion with less expense for repairs, and in most cases, the crews are better satisfied; the regular engineer will give his engine much closer attention than it would otherwise receive; discouragement exists among enginemen when placed in the pool and much of the work usually done by them is, under the pooling system, neglected. When first pooled, engineers show a marked increase in mileage, but the duration of this is short. With somewhat worn engines and somewhat weak flues much difficulty is experienced owing to the indifference of the enginemen resulting in a less average mileage than that of the regular engines. Most of the year a regular crew will be able to follow the engine, but in short periods when this cannot be done, with an extra board to draw from, these conditions can be taken care of. A freight engine with a regular crew will have more trips credited when handling full tonnage, while the passenger engine makes up time and arrives at terminals more often on time than if handled by different crews.

If the delays which occur in pooling were taken into consideration the money paid for overtime would go far towards paying interest on the cost of additional locomotives as well as a big percentage of the cost for repairs due to indifferent handling by the pool crew.

Reference is made to reports of the Inter-State Commerce Commission, in which it is shown that two of the large trunk lines maintaining regular crews make the best showing of all the railroads in the United States. Pooling creates indifference with the roundhouse force, resulting in neglect to make proper repairs, and which the regular crew would complain of. This serves two purposes: it locates the indifferent mechanic and keeps the roundhouse foreman informed as to the quality of work being done. Among the many things, continues the paper, to be said in favor of pooling are: In extremely busy times, congestions and possible blockades may be prevented by pooling, though too heavy tonnage at such times results in more engine failures, which if prevented adds a certain per cent. to the gross tonnage handled, and engines can be kept on the road almost constantly, so long as they are in serviceable condition.

The discussion disclosed the fact that pooling decreases the efficiency of enginemen; that the crew should be considered as well as the engine; that engineers neglect to report work which frequently results in engine failures; that it is difficult to locate who is at fault; that pool engines require more repairs and that the pooling of enginemen is demoralizing to the extent that if returned to regular engines it still exists. The discussion was closed by a motion

"that the association go on record as favoring regularly assigned engines, both freight and passenger," and the motion prevailed.

#### MR. W. J. HURLEY'S PAPER.

Ninth paper: "What is the Best Method of Handling Locomotives at Terminals to Reduce Terminal Delays?"

The requisites presented in the paper were: A roundhouse foreman possessing executive ability and sound judgment; an engine dispatcher familiar with local affairs, conversant with the assignment and condition of locomotives operating over his division; a foreman in charge of all hostlers, fire cleaners and ashpit laborers, thus being responsible for movement of power from the ashpit to the coal chute and roundhouse. The number of ashpits should be according to number of engines handled, a separate pit being assigned for switch engines. Facilities for promptly coaling locomotives and sufficient trackage to handle them with the least delay. The paper refers to the failure of engine house expansion to keep pace with the increase of business which delays handling power in busy seasons; that the size of the mechanical force should be governed by conditions and that engineers should be educated to report work in a systematic way.

The successful engine inspector is depicted as a man alive to the situation and able to determine quickly whether an engine is in condition to go out before making all the repairs reported or observed by himself. A discussion of the paper indicated that the management often failed to appreciate the lack of track room at terminals; that an inefficient roundhouse foreman, frequently a result of small salary, is not conducive to reducing terminal delays, and that delays can be reduced by using roundhouses for engine storage instead of for a repair shop.

#### OIL BURNING LOCOMOTIVES.

The tenth and last paper was under the caption: "The Oil Burning Locomotive. The Device Used. The Methods of Operation and the Difficulties Met With in Its Use." The paper opens with a statement of reasons why a number of western railroads took up the subject of substituting oil for coal, the principal one being that of economy in cost of fuel and in the early experiments it was found that a ton of crude oil, at about \$3 per ton, gave the equivalent to coal costing \$8.60 a ton on tenders.

During the experimental period the system of using oil as a fuel for locomotives passed through a gradual evolution until now the burners used are of two general types, classified as outside and inside mixers, each seemingly giving satisfaction, indicating that the design of burner is not of vital importance. The results of burning oil improves the

efficiency of a boiler about 25 per cent. over that of coal.

As a rule, oil burning locomotives haul nearer their maximum tonnage than a coal burner, and in passenger service maintains the schedule better, not alone due to the increased steaming capacity, but, as well, to their freedom from delays from poor coal, foul fire, cleaning front ends and other ailments common to coal burning locomotives. A chapter is devoted to describing the burners and other apparatus used in connection with oil fuel, stress being laid on the importance of the engineer and fireman working together, as every change of the throttle or reverse lever must immediately be met with a change in the oil supply and adjustment of the atomizer. The advantages of oil burning are stated as quickness with which engines can be ready for service; decreased cost of handling at terminals and convenience of taking water and oil at the same time. The claim department has no fires to pay for and the bridges along the road are practically immune, but to pay for all these advantages the mechanical department bears the brunt of the burden in the increased cost for repairs.

The oil flame inflicts severe punishment on the flues and fire box, it being exceptional for an engine to run two years without renewing the fire box, or longer than twelve months with a set of flues. Side sheets cannot be patched to advantage, the patch being soon burned from the intense heat. Very poor results have attended attempts to use the Vanderbilt type of fire box, the heat causing them to sag and bulge, and in some instances a renewal of the box was necessary following three months' service. With standard fire boxes radial stays prove superior to button-head crown bolts, the former being less affected by heat as well as insuring better circulation above the crown sheet. Seams are dispensed with wherever possible. The committee believes that oil burning engines have come to stay on western lines, there being at present 500 on the Southern Pacific, 515 on the Santa Fe Coast and Texas lines; the Salt Lake Line has 75 and all the small lines in California use oil exclusively.

Owing to a lack of experience with oil fuel on the part of nearly all the traveling engineers, but little of interest was brought out in addition to that given in the paper other than that there were less flue failures with oil than with coal, and less delays incident to taking coal, cleaning fires and ashpans.

#### CONVENTION A GREAT SUCCESS.

The convention was a success in every way, there being 375 members present, who gave the closest attention, and the spirited debates attested that the attendance was due to a desire to do business.



# Of Personal Interest

Mr. T. Harris has been appointed division car foreman of the Canadian Pacific at North Bay, Ont.

Mr. J. R. Riggs has been appointed general foreman of the Michigan division of the Vandalia Railroad.

Mr. W. J. Schlacks, superintendent of machinery of the Colorado Midland, has resigned to go into other business.

Mr. C. S. Mills has been appointed master mechanic of the Buffalo & Susquehanna Railroad Company at Galeton.

Mr. G. Thomson has been appointed assistant general foreman of the Lake Shore & Michigan Southern at Collinwood, O.

Mr. W. D. Cox has been appointed general foreman at Air Line Junction, Ohio, on the Lake Shore & Michigan Southern.

Mr. Willard Kells, master mechanic of the Lehigh Valley at Sayre, Pa., has been transferred to Buffalo, N. Y., vice Mr. F. R. Cooper, resigned.

Mr. A. H. Cairns has been appointed master mechanic of the Denver & Rio Grande Railroad at Grand Junction, vice Mr. J. W. Hardy, resigned.

Mr. E. F. Flory has been appointed general foreman, Pen Argyl Shops, of the Lehigh & New England Railroad, vice Mr. H. L. Wren, resigned.

Mr. D. T. Forbes, superintendent of the Victoria division of the Southern Pacific, has resigned to become superintendent on the Colorado Southern.

Mr. F. Cochrane has been appointed general foreman of the car department of the Lake Erie & Western at Toledo, Ohio, vice Mr. G. W. Diebert, transferred.

Mr. De Forest J. Adams has been appointed roundhouse foreman for the Chicago & Northwestern Railway at Boone, Ia., vice Mr. C. L. Harris, resigned.

Mr. C. B. Smith, formerly master mechanic at Boston, Mass., on the Boston & Maine, has been appointed mechanical engineer of that road, with office in Boston.

Mr. G. C. Johnson has been appointed master mechanic of the Lincoln division of the Chicago, Burlington & Quincy Railway, vice Mr. J. Dietrich, promoted.

Mr. Lewis Ord, son of Mr. C. R. Ord, of the Canadian Pacific, has been appointed locomotive foreman on the Canadian Northern Railway at Parry Sound, Ont.

Mr. J. H. Parker has been appointed assistant traffic manager of the National Steel & Wire Co., with headquarters at New Haven, Conn., vice Mr. J. A. Moore, resigned.

Mr. F. E. Kennedy has been appointed master mechanic of the Sheridan division of the Chicago, Burlington & Quincy Railway, vice Mr. G. C. Johnson, transferred.

Mr. C. Banks, heretofore engineer of tests on the Great Northern, has been appointed mechanical engineer of the Texas & Pacific Railroad with office at Marshall, Texas.

Mr. W. G. Edgar has been appointed master mechanic of the St. Louis, Iron Mountain & Southern, with headquarters at Helena, Ark., vice Mr. J. A. Greenoe, resigned.

Mr. W. B. Poland, chief engineer and manager of the Alaska Central, has resigned to accept a position with a road being built by American capital in the Philippine Islands.

Mr. H. B. Suttan, formerly in the employ of the Newton & North Western Railway, has been appointed night foreman of roundhouse at Carroll, vice Mr. Huffman, resigned.

Mr. W. W. Huffman, formerly night foreman of the Chicago & Northwestern at Carroll, has been appointed night foreman of roundhouse at Boone, vice Mr. Adams, transferred.

Mr. W. M. Vandersluis has been appointed signal engineer of the Cleveland, Cincinnati, Chicago & St. Louis, with office at Cincinnati, Ohio, vice Mr. G. H. Macdonough, resigned.

Mr. S. Vincent, heretofore foreman of repairs in the Grand Trunk Railway shops at Stratford, Ont., has been appointed locomotive foreman of the Canadian Northern at Kamsack, Sask.

Mr. D. Gallaudet, general foreman of the Glenwood shops of the Baltimore & Ohio, has been promoted to the position of master mechanic of the Chicago division, to succeed Mr. J. E. Davis.

Mr. J. Dietrich has been appointed assistant superintendent of motive power of the Chicago, Burlington & Quincy and of the Lines West of the Missouri River, with headquarters at Lincoln, Neb.

Mr. P. T. Dunn, general foreman of the Pennsylvania Lines West, at Cincinnati, Ohio, has been appointed master mechanic of the Northwest system at Chicago, vice Mr. N. M. Loney, resigned.

Mr. Henry Carrick, district foreman of the Oregon Short Line at Montpelier, Idaho, has been appointed division master mechanic at Pocatello, Idaho, vice Mr. W. J. Tollerton, resigned.

Mr. J. Dun, who resigned as chief engineer of the Atchison, Topeka & Santa Fe System, has been appointed consulting engineer of the Atchison, Topeka & Santa Fe Railway, office at Chicago.

Mr. W. W. Breckenridge, heretofore master mechanic at Crookston, Minn., has been appointed master mechanic of the Great Northern Railway, at Great Falls, Mont., vice Mr. F. M. Fryburg, promoted.

Mr. R. L. Wyman, formerly general foreman of the Delaware, Lackawanna & Western at Utica, N. Y., has been appointed master mechanic of the Lehigh & New England, with office at Pen Argyl, Pa.

Mr. H. E. Culbertson has been appointed master mechanic of the McCook division of the Chicago, Burlington & Quincy Railway, with office at McCook, Neb., vice Mr. F. E. Kennedy, transferred.

Mr. R. H. Innes, late superintendent of transportation of the San Antonio & Aransas Pass, has become superintendent of wharf terminals at Galveston for the Santa Fe and the Galveston, Houston & Henderson.

Prof. Paul Anderson, formerly occupying a chair at the Kentucky State University, has been appointed superintendent of tests of the Cincinnati, New Orleans & Texas Pacific, with office at Lexington, Ky.

Mr. Thomas B. Arnold, until recently with the Railway Steel Spring Company, has been appointed Southwestern representative for the Detroit Seamless Steel Tube Company, of Detroit. His headquarters are at St. Louis, Mo.

Mr. F. M. Crowell, assistant engineer of the Southwest System at Pittsburgh, Pa., has been appointed engineer of maintenance of way of the Pennsylvania Lines West, at Cambridge, Ohio, on the Northwest System, vice Mr. G. Scott, transferred.

Mr. W. R. Wilson has been appointed division general foreman of the Lake Shore & Michigan Southern at Elkhart, Ind., vice Mr. G. Thomson, transferred. Mr. Wilson's jurisdiction will include La Porte and all points east on the main line.

Mr. T. H. Goodnow has been appointed master car builder of the Michigan Southern division of the Lake Shore & Michigan Southern (exclusive of the Toledo & Air Line Junction), with office at Englewood, Ill., in place of Mr. Downing.

Mr. W. J. Hoskin has been appointed assistant superintendent of machinery on the Missouri Pacific. He had been connected with the Frisco System and with the Chicago & Eastern Illinois, and was previously in the service of the C., B. & Q. at Hannibal.

Mr. W. G. Besler, vice-president and general manager of the Central Railroad of New Jersey, has been elected an honorary member of the St. Louis Railway Club, of which he was once president. Mr. Besler did much to make it the successful organization that it is to-day.

Pacific since 1904. He was, previous to this, superintendent of motive power of the Chicago Great Western.

The birthday of Mr. Henry S. Bryan, superintendent of motive power of the Duluth & Iron Range Railroad, was remembered on that road in a very pleasant manner. Early last month, when his natal day arrived, the S. M. P. was made the recipient of a loving cup presented by the foremen of the various motive power departments, and with the loving cup was a bouquet of roses. The cup is a handsome specimen of the silversmith's art, and was inscribed with the words, "Presented to Henry S. Bryan, September 7, 1906, by J. A. Graves, Wm. Durdin, P. Swanson, F. A. Howerton and W. G. Sutherland." This proof of kindly feeling

At the recent meeting of the Traveling Engineers' Association, held in Chicago, the following officers were elected for 1906-7:

President, W. J. Hurley, N. Y. C. & H. R. Buffalo, N. Y.

First Vice-President, A. M. Bickel, L. S. & M. S., Elkhart, Ind.

Second Vice-President, J. A. Talty, D., L. & W., Buffalo, N. Y.

Third Vice-President, C. F. Richardson, St. L. & S. F., St. Louis, Mo

Secretary, W. O. Thompson, N. Y. C. & H. R. Oswego, N. Y.

Treasurer, C. B. Conger, Int. Cor. School, Chicago, Ill.

Members of Executive Committee: J. C. Graff, C. & N. W., Winona, Minn.; W. H. Bradley, C. & N. W., Chicago, Ill.; F. C. Thayer, Southern, Atlanta, Ga.

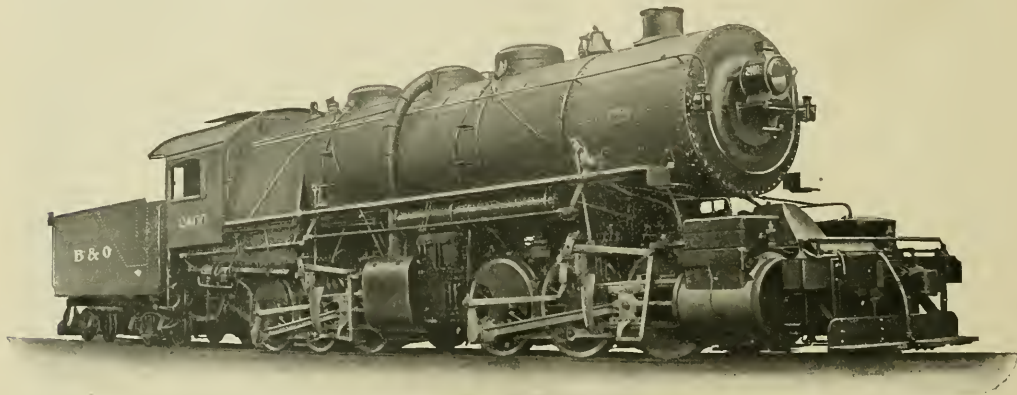

MALLET ARTICULATED COMPOUND ON THE BALTIMORE & OHIO.

J. E. Muhlfeld, General Superintendent of Motive Power.

American Locomotive Company, Builders.

Mrs. Frances A. W. McIntosh, formerly manager of the Standard Tool Company, Cleveland, Ohio, and more recently connected with the advertising department of Power, New York, has taken charge of the publication department of the Norton Company, Worcester, Mass.

Mr. G. Thomson, heretofore division general foreman of the Lake Shore & Michigan Southern, at Elkhart, Ind., has been appointed division general foreman of that road, the Lake Erie Alliance & Wheeling and the Dunkirk, Allegheny Valley & Pittsburgh, with office at Collinwood, Ohio, vice Mr. J. McCabe, transferred.

Mr. David Van Alstyne has tendered his resignation as mechanical superintendent of the Northern Pacific to accept a position with the American Locomotive Company. Mr. Van Alstyne has been the executive head of the motive power department of the Northern

and high esteem on the part of his co-workers in railroad life is very much appreciated by Mr. Bryan.

At the recent convention of the Master Steam Boilermakers' Association held in Chicago the following officers were elected: President, Mr. John S. Sullivan of the Pennsylvania Lines, Columbus, O.; first vice-president, Mr. George H. Judy of the B. & O., Pittsburgh, Pa.; second vice-president, Mr. J. W. Russell of the P. R. R., Renova, Pa.; secretary-treasurer, Mr. A. L. Woodworth of the C. H. & D., Lima, O.; Mr. George H. Williams, of B. M. Jones & Co., Medford, Mass. The following is the executive committee: Messrs. George W. Kelly, chairman of the New Jersey Central, Elizabeth, N. J.; James Walker, John McNally, D. B. Swinton and W. W. McLellan. Montreal, Canada, was the place chosen for the convention city next year, the meeting to be held August 20, 1907.

#### Obituary.

We are sorry to have to record the death of Oscar Huber, chief of the Galena Signal Oil Company's sales department in Buenos Ayres. He was also the chief of the expert department, and his technical skill and knowledge of mechanical matters was of a high order. His judgment was deferred to by his many friends in the mechanical departments in the railway of South Africa. In the sales department he evinced the same good judgment and ability that made him successful in the technical part of his business. Friendship meant to him everything that the word implies, and there are many throughout South America who will deeply mourn his loss.

The sixteenth annual convention of the Association of Railway Superintendents of Bridges and Buildings is to be held in Boston, October 16, 17 and 18.

**Tank Engine, Northern of France.**

The remarkable type of tank engine shown in our illustration was recently built by the Chemin de fer du Nord, at their shops at La Chapelle, France. The engine is a compound with low pressure cylinders in front and high pressure behind. There are two of each, or four cylinders in all, and each set of six driving wheels and a pair of small carrying wheels, form one truck. These trucks are capable of a swiveling motion independent one of the other, so that although the engine has a long total wheel base, the rigid bases are each comparatively short.

The cylinders are 16 and 25x27 ins., and the driving wheels are 51 ins. in diameter. The bogie wheels are 33 ins. in diameter. The wheel base of each truck—that is, measured from small wheel to driver at the other end of the truck—is 18 ft. 11½ ins., and the total wheel base of the engine is 40 ft. 11¼

locomotive with four cylinders with considerably increased power.

Writing to RAILWAY AND LOCOMOTIVE ENGINEERING concerning this engine, Monsieur G. Du Bonsquet, chief engineer of material and traction, says in effect:

I believe I ought to call your attention to the fact that this locomotive is not of the Mallet type, it is totally different. Of the articulated locomotives built up to this time, some have one motor truck placed in front like those of M. Mallet, others have two motor trucks, but these latter have strong yokes and buffers; the rear truck restricted, so to speak, by its tractive effort and by its stops, thus loses a good deal of its mobility. The two motor trucks of our locomotive are true bogies, absolutely free to assume all positions on the track. Its boiler rests on a frame made of a beam of which the ends are enlarged

**Exhibits, Traveling Engineers' Convention.**

American Locomotive Equipment Co., Chicago, showed a chart of test of the hollow arch compared with the solid arch and no arch.

S. F. Bowser & Co., Inc., Fort Wayne, Ind., distributed circulars showing Bowser oil storage system as used at locomotive stations.

Century Preserver Co. distributed, through their sales agent, W. A. Ahrens, Chicago, some literature concerning their black metal preserver for covering the exposed surfaces of metal.

The Chicago Pneumatic Tool Company have just issued their new Compressor catalogue consisting of 118 pages, printed in two colors. Several new types and sizes of Compressors are shown in this catalogue including their new Hamilton Corliss Machines. Those interested will receive copy upon re-

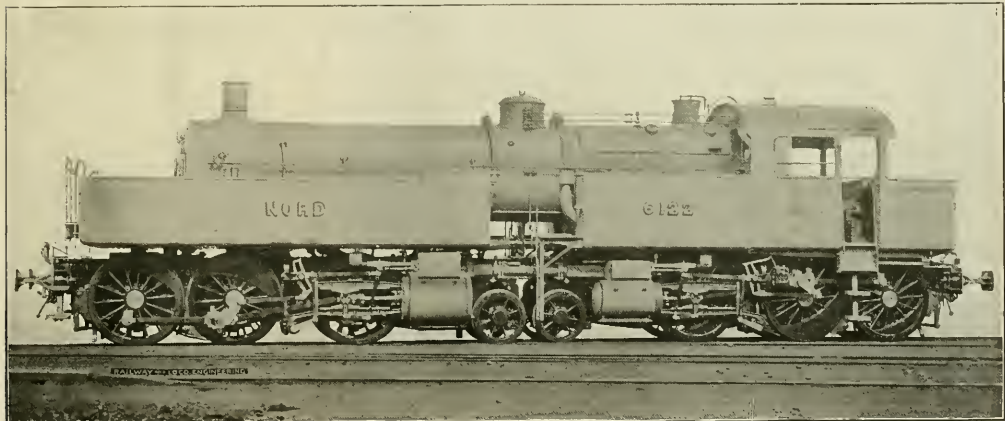

TANK ENGINE FOR THE CHEMIN DE FER DU NORD, FRANCE.

ins. The diameter of the boiler is 51 ins. There are 130 tubes each about 15 ft. 7 ins. long and there is a total heating surface of tubes and fire box of 2,361 sq. ft. The pressure carried is 228 lbs. to the square inch. Steam from the boiler goes to the cylinders and through them to the smoke box through the steam pipe which runs from the dome down to a swivel joint placed over the kingpin of the truck with its axis in line with the kingpin. From the high pressure cylinders it goes to the low pressure cylinders through a length of flexible pipe. The exhaust is led to the smoke box through another swivel joint in the center of the truck carrying the low pressure cylinder. An arrangement is made whereby both the high and the low pressure cylinders may be supplied with high pressure steam when necessary, in starting or on grades. In this case the engine operates as a simple

and provided with means for attaching the elastic springs. This arrangement, comparable to that of the box of a carriage on wheels, rests on its frame, like the latter, on two independent bogies. The elongations of these bogies support exteriorly the motor cylinders. The rear bogie, which receives the high pressure cylinders, is able to move horizontally about a cylindrical pivot. The front bogie carrying the low pressure cylinders is able to move in all directions by its connection to the rear bogie, by turning about a spherical pivot. It is thus able to adjust itself to the height of curves with ease and perfect security. This locomotive has been designed in the office of the company and built in our works.

Cast iron melts at 2,192 degrees and vaporizes at 3,300 degrees. Lead melts at 626 degrees.

quest direct to the Chicago office. This company have opened an office at 1012 Memphis Trust Building, Memphis, Tenn., in charge of Mr. J. Francis Small, in order to effectively deal with their business in the Southern States.

Crandall Packing Co., Palmyra, N. Y., exhibited their Helios throttle stem packing, Helios air pump packing.

Joseph Dixon Crucible Co., Jersey City, N. J., had an exhibit of Dixon's Ticonderoga graphite air brake and triple valve grease. This grease is applicable to engineers' brake valves, air brake cylinders, and their Flake graphite as a lubricant for air pumps.

Fisher Automatic Slack Adjuster and Railway Equipment Co., Murphysboro, Ill., distributed some printed matter concerning their brake slack adjuster.

Franklin Railway Supply Co., Frank-

lin, Pa., showed their method of driving box lubrication.

Garlock Packing Co., Chicago, showed samples of their Garlock throttle, air pump and valve stem packing, also their Pilot metal packing.

G. H. Hammett, Troy, N. Y., showed Trojan high pressure metal packing.

Jenkins Brothers, New York, exhibited their "Jenkins 96" sheet packing for making joints, etc., also their gasket tubing and union rings. The Jenkins water cock washers and discs, also a line of the well-known Jenkins valves. They also exhibited Palmetto packing for air pumps, throttle stems, small valves, and, indeed, for anything requiring steam or an air tight packing. This packing is manufactured by Greene, Tweed & Co., New York.

numerous blue prints showing the application of their system in the care of locomotive boilers.

The Steam Appliance Co., Milwaukee, showed the "Root" reducing valve.

Wallace & Kellogg, Minneapolis, Minn., exhibited a model of variable exhaust nozzle.

Julien L. Yale & Co., Chicago, distributed some literature concerning the Miller water-heating washing, and refilling system for locomotive boilers.

#### Traveling Engineers' Association.

##### PAPERS FOR NEXT YEAR.

At the close of the Traveling Engineers' convention, the regular papers all having been disposed of, the subject for papers for the next convention was



TALMAGE MFG. CO.'S RECEPTION ROOM AT THE TRAVELING ENGINEERS' CONVENTION, CHICAGO.

The Leslie Co., Lyndhurst, N. J., exhibited their steam-heat pressure regulator made in various sizes for railroad use.

Michigan Lubricator Co., Detroit, exhibited bull's eye lubricators with two, three, four and five feeds, respectively.

The National Metallic Packing Co., Oberlin, Ohio, had circulars explaining their locomotive type of metallic packing.

Storrs Mica Co., Owego, N. Y., exhibited their Storrs Neverbreak Headlight Chimneys. These are made of strips of clear mica bound with rims of tin. These chimneys were referred to particularly in our August issue, page 392.

Talmage Mfg. Co., Cleveland, exhibited blow-off valves and Rubra boiler oil used in connection with the Talmage system of boiler washing and water purification. The company also exhibited

considered, those adopted being as follows:

1. "The operation and maintenance of the latest make of lubricators, hydrostatic and mechanical, for valves and cylinders using saturated and superheated steam."
2. "Waste of energy in railroad operation."
3. "Air sanding devices and others operated by air. Their operation and maintenance."
4. "The advantages of the mechanical stoker as compared with hand firing."
5. "The best method of eliminating the smoke nuisance on soft coal burning engines."
6. "The advantages of the hot water system of washing and filling boilers."
7. "In what measure can the traveling engineer most quickly locate the cause for an engine steaming poorly, without changing the draft arrangements?"

Chicago, Toronto and Jamestown.



## Here She Comes!

Just finishing her run having made every station on schedule time. And her bearings and pins are cool as cucumbers.

This is the kind of record every engineer can turn in who uses Dixon's Flake Graphite on his engine. Hot pins and bearings, and delays due to friction troubles of any kind, absolutely will not occur if Dixon's Graphite is judiciously used.

To each and every one who doubts this fact, or wants to see it proven, we desire to send a liberal free sample and Booklet 69-C, which tells how and where to use Dixon's Graphite.

**JOSEPH DIXON  
CRUCIBLE CO.**  
Jersey City, N. J.



“ **J. M.** ”



**RAILROAD  
SUPPLIES**

**OUR NEW CATALOG**

Catalogue No. 250 should be in the hands of every Manager, Purchasing Agent, Superintendent, Master Mechanic and Shop Foreman. It contains a complete line of “J.-M.” Asbestos and Magnesia Materials which have been adopted by the leading railroad interests throughout the country as standard.

**WRITE NEAREST BRANCH  
FOR COPY TO-DAY**

- Smoke Jacks
- “Transite” Fireproof Lumber
- Asbestos and Magnesia Locomotive Lagging
- “Vulcabeston” Pump Packing
- “Vulcabeston” Gaskets
- “Vulcabeston” Rope Packing
- Train Pipe Covering
- “Kearsarge” Gaskets
- All grades of Asbestos and Magnesia Pipe Covering
- Hair Felt
- “Keystone” Hair Insulator
- Asbestos Cements
- “Retort” Cements
- “Canadax” Wick Packings
- High Pressure Asbestos Packing
- Asbestos Roofing
- Portland Sectional Conduit

**H. W. JOHNS-MANVILLE CO.**

Manufacturers of Asbestos and Magnesia Products, Asbestos Roofings, Packings, Electrical Insulating Materials, “Nears” Fuse Devices, Electric Railway Supplies, etc.

- |              |             |               |
|--------------|-------------|---------------|
| NEW YORK     | ST. LOUIS   | MINNEAPOLIS   |
| MILWAUKEE    | PITTSBURG   | DALLAS        |
| CHICAGO      | CLEVELAND   | SAN FRANCISCO |
| BOSTON       | NEW ORLEANS | LOS ANGELES   |
| PHILADELPHIA | KANSAS CITY | SEATTLE       |
|              | LONDON      |               |

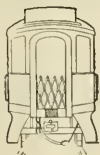

327

Va., were nominated as places for holding the next convention, Chicago receiving the largest number of votes.

A very handsome catalogue dealing with the Acetylene Safety Storage System for Railway Lighting has recently been issued by the Commercial Acetylene Company, of New York. It is well illustrated and fully describes the safety storage system used by the company. The whole science of railway car lighting, as carried out with acetylene for the illuminant, is treated in a very comprehensive and readable way and facts and figures concerning the generating plant on the Delaware, Lackawanna & Western, at Hoboken, N. J., are given. Station lighting is also taken up and acetylene used in locomotive headlights is explained, together with the application of the safety system to locomotives, signal lighting and portable acetylene projectors for wrecking purposes are illustra-

passenger service. All of the designs presented in the book to the number of twenty-six, are illustrated with half-tone engravings, each being accompanied by a table giving the leading dimensions of the engine shown. It also gives the chief dimensions of each design in tabular form, arranged in the order of total weights. Railroad men will find this arrangement convenient when considering the type and design of locomotives for special conditions. This series of pamphlets will ultimately cover the entire product of this company. Copies may be had upon request, addressed to their head office, Trinity Building, New York.

**Precious Ballast.**

The Eastern Railway of Mexico, says a correspondent of the San Francisco Chronicle, will be ballasted with gold ore between Texico and Rio Puerto, a dis-



SCENE ALONG THE LAKE OF BAYS RAILROAD IN THE MUSKOKA REGION

ted and described. The handy little portable acetylene light, standing on a cylinder 4 ins. diameter by 9 ins. long, which gives a 25 candle power flame for 12 hours, is part of the company's product. The pamphlet, which is the same size as RAILWAY AND LOCOMOTIVE ENGINEERING, concludes with engravings of the very tasteful designs of car lamps supplied by the company. Write direct to them, 80 Broadway, New York, if you want a copy.

tance of 270 miles. This ballast rock is obtained from the gravel bed adjacent to the new line of the road.

Repeated assays have shown that the ballast runs upward of \$2 in gold to the ton. About 4,500 tons of rock are used to the mile, making the value of the gold \$9,000 to each mile of road, or \$2,430,000 for the 270 miles. The gold values in the rock are not sufficient to make it a mining proposition, but passengers will ride over the most valuable piece of ballasting in the world.

The American Locomotive Company have just issued a catalogue on the subject of Atlantic Type, or 4-4-2 Passenger Locomotives. This is the second of a series of catalogue pamphlets illustrating and describing their designs. The pamphlet begins with a description of the 4-4-2 locomotive, and states the advantages which the type offers for fast

The Hendrick Mfg. Company, of Carbondale, Pa., are introducing an adjustable plate spark arrester for use in locomotive front ends. These smoke-box plates have a series of adjustable small bolts upon which overlapping portions of the perforated plate may readily

move when heated and resume their former position when cooled. The object is to allow for expansion and contraction, and so obviate any tendency to crack or warp. Mr. Charles Law, of Pittston, Pa., is showing the new product of the Hendrick Co. to leading railroad men.

#### Railroad Sleepers.

It is gratifying to learn that the use of cedar as a wood for railway sleepers is proving to be the most durable of any kind of timber hitherto in use. As a high priced article in the lumber market, it has not been generally used on railways until the Grand Trunk Railroad in Canada used a large number in some of the remote portions of their road, where the ties have proved to be practically imperishable. The wood is brittle and easily broken in case of derailment, but otherwise appears to be eminently satisfactory if all that is said about it is true. About 2,200,000 were used in Canada in 1905, and this number will be more than doubled this year.

"Through Frisco's Furnace" is the title of a pamphlet recently got out by the Joseph Dixon Crucible Company, of Jersey City. The purpose of the publication is to show how well Dixon's Silica-Graphite Paint preserves the maximum strength of steel work of high buildings, so that severe strains can be successfully resisted. There are seven half tones, which are excellent views of modern steel frame buildings showing how they went through the ordeal of earthquake and fire last April. The opening page has an interesting graphic representation of the devastated area in San Francisco in 1906, and upon that is laid the smaller area destroyed by fire in Chicago in 1871, Boston in 1872 and Baltimore in 1904. The various areas are differently shaded so that the comparative extent of each is at once apparent to the eye. The pamphlet forms an interesting contribution to the literature of the subject and may be had by applying direct to the company.

#### Lightening the Weight.

The poet Wordsworth refers with fine impressiveness to "that blessed mood, in which the burden of the mystery, in which the heavy and the weary weight of all this unintelligible world is lightened." The mood that the poet referred to undoubtedly is that high philosophic mood that comes to the mind that is at peace with itself and rejoices in the contemplation of Nature in her beauty and solitude. The poet knew little or nothing of mechanical toil or he would have found that there are other weary weights besides the mystery of the world to think of. The young railroad man finds that there is a weight of ignorance that

sinks him to the earth when he contemplates the wilderness of mechanical appliances used on railways.

RAILWAY AND LOCOMOTIVE ENGINEERING lightens his burdens and clears the mysteries for him. We have books also that thousands of railroad men have been reading and gathering knowledge from. A few of our books are as follows:

"Machine Shop Arithmetic." Colvin and Cheney. This is a book that no person engaged in mechanical occupations can afford to do without. Enables any workman to figure out all the shop and machine problems which are so puzzling for want of a little knowledge. We sell it for 50 cents.

"Firing Locomotives." Sinclair. Treats in an easy way the principles of combustion. While treating on the chemistry of heat and combustion, it is easily understood by every intelligent fireman. The price is 50 cents.

"Skeevers' Object Lessons." Hill. A collection of the famous object lesson stories which appeared in this paper several years ago. They are interesting, laughable, and, best of all, they are of practical value to-day. \$1.00.

"Standard Train Rules." This is the code of train rules prepared by the American Railway Association for the operating of all trains on single or double track. Used by nearly all railroads. Study of this book would prevent many collisions. Price, 50 cents.

"Mechanical Engineers' Pocketbook." Kent. This book contains 1,100 pages, 6x3¼ ins., of closely printed minion type, containing mechanical engineering matter. It ought to be in the bookcase of every engineer who takes an interest in engineering questions. We use it constantly as a reference for questions sent to us to be answered. Full of tables and illustrations. Morocco leather, \$5.00.

"Locomotive, Simple, Compound and Electric." Reagan. An excellent book for people interested in any kind of locomotive. It will be found particularly useful to men handling or repairing compound locomotives. It is the real locomotive up to date. \$2.50.

"Simple Lessons in Drawing for the Shop." By O. H. Reynolds. This book was prepared for people trying to acquire the art of mechanical drawing without a teacher. The book takes the place of a teacher, and has helped many young men to move from the shop to the drawing office. 50 cents.

"Locomotive Running Repairs." By L. C. Hitchcock. This book contains directions given to machinists by the foreman of a railroad repair shop. It tells how to set valves, set up shoes and wedges, fit guides, care for piston packing, and, in fact, perform all kinds of

# GOLD Car Heating and Lighting Co.

Manufacturers of

**ELECTRIC,  
STEAM AND  
HOT WATER  
APPARATUS  
FOR RAILWAY CARS**

**EDISON  
STORAGE  
BATTERY  
FOR RAILWAY CAR  
LIGHTING**

Largest Manufacturers in the World  
of Car Heating Apparatus

Catalogues and Circulars  
cheerfully furnished

Main Office, Whitehall Bldg.  
17 BATTERY PLACE  
NEW YORK

# Homestead Valves

Straightway, Three-way and Four-way, and

# Homestead Locking Cocks

Are Famous the World Over

They cost more, but are worth very much more than other makes. You try them and see.

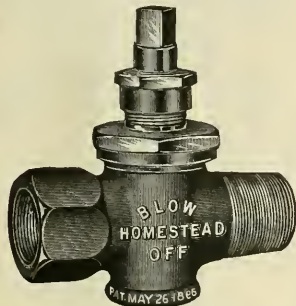

Brass. 1 1/4 in., \$6.00 net

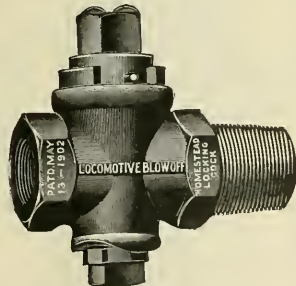

Iron Body. Brass Plug, 1 1/4 in., \$4.00 net

## Homestead Valve Mfg. Co.

WORKS, HOMESTEAD, PA. PITTSBURG, PA.

## American Locomotive Sander Company

13th & Willow Sts., Philadelphia, Pa.

Proprietors and Manufacturers

LEACH, SHERBURNE, DEAN, SANDERS  
HOUSTON, "SHE" and CURTIS

### THE ROBERT W. HUNT & CO.

Bureau of Inspection, Tests and Consultation,  
1137 THE ROOKERY, CHICAGO,  
66 Broadway, New York. Park Building, Pittsburgh.  
31 Norfolk House, London, Eng.

Inspection of Steel Rails, Splice Bars, Railroad Cars, Wheels, Axles, etc. CHEMICAL LABORATORY—Analysis of Ores, Iron, Steel, Oils, Water, etc. PHYSICAL LABORATORY—Test of Metals, Drop and Pulling Test of Couplers, Draw Bars, etc.

Efficiency Tests of Boilers, Engines and Locomotives.

work that need a thoughtful head and skillful hands. 50 cents.

"Care and Management of Locomotive Boilers." Raps. This is a book that ought to be in the hands of every person who is in any way interested in keeping boilers in safe working order. Written by a foreman boilermaker. Also contains several chapters on oil burning locomotives. Price, 50 cents.

"Locomotive Link Motion." Halsey. Any person who gives a little study to this book ceases to find link motion a puzzle. Explains about valves and valve motion in plain language. Price, \$1.00.

RAILWAY AND LOCOMOTIVE ENGINEERING is a practical journal of railway motive power and rolling stock, and it is so not only in name but in reality. By reading it you get a knowledge of what

come these difficulties, the Niles-Bement-Pond Company, of New York, has placed on the market a newly designed hydraulic wheel press of 600 tons capacity. In this tool the distance between the ram and the resistance post, which is a steel casting, is 8 ft. 3 ins. Four tension bars are used and the post is so arranged that the weight is entirely removed from the tension bars. The cylinder, which is made of cast steel, has an outside diameter of 27 ins. The pump has three plungers and is on the side of the machine handy for the operator. A 12 1/2 h.p. motor is used to operate the pump. The height between the tension bars is 90 ins. and the machine will take wheels 84 ins. in diameter on the tread. The whole is so arranged that no

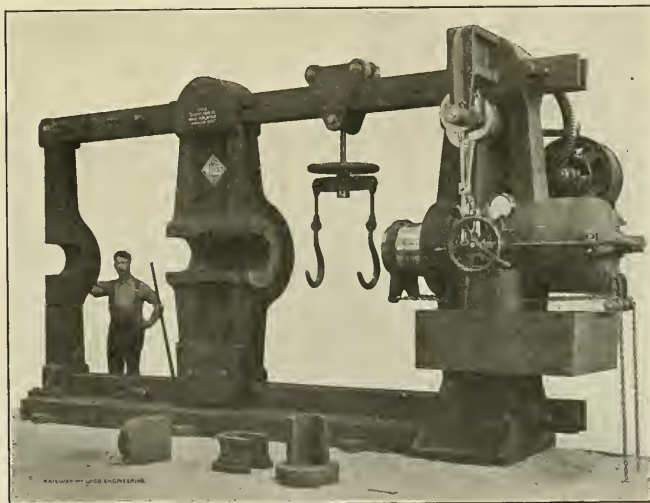

HYDRAULIC WHEEL PRESS, 600-TONS CAPACITY.

others think and do. \$2.00 per year; bound volumes, \$3.00.

### Hydraulic Wheel Press.

The increase in the use of wheels with steel tires has caused several changes to be made in railway repair shop equipment. Until very recently hydraulic wheel presses of more than 400 tons capacity had not been known. Many shops have found difficulty in removing steel tired wheels from their axles, due to the increase of pressure caused by shrinking on the tires after the usual pressure of 150 tons has been exerted to place the wheel center on the axle. In some instances it has been necessary to remove the tires or drill the hub in order to remove the center from the axle.

Realizing the importance of a machine of such capacity as would over-

strains are transmitted to the base plate, as the pressure is taken by the tension bars. The cylinder is lined with copper expanded into place and burnished. The piston is packed with cup leather, and while tight causes little friction. The ram is counter-weighted for quick return when the release valve is open. The safety valve can be set to open at any desired pressure, and it is secured by a lock box. The pressure gauge is graduated for tons of pressure and for pounds per square inch on the ram. The water tank is bolted under the cylinder, and receives the discharge and supplies the pumps. Several of these machines are now in use.

### Etiquette in India.

Questions of etiquette do not trouble American railway men to any great extent, but they seem to be living issues

among railway men in India. We notice that a correspondent puts the following knotty problem to the editor of the Railway Times, of India: A is transferred to Chutneepur, where he knows nobody. Is it his and his family's social duty to call and leave cards on the old residents, or is it the duty of the old residents to welcome the new?

An enjoyable time was spent by the members of the Steam Boiler Makers' Association one day during their convention last month in the Windy City, when they were guests of the Chicago Pneumatic Tool Company. The afternoon of the 6th, the company arranged for the necessary automobiles to accommodate one hundred and sixty-four members and their wives, and gave them all an automobile ride through Washington and Jackson Parks, or, in other words, made a tour through the southern

friends of the company. The entertainment was generously given and handsomely done, and the little booklet will be an interesting souvenir of the pleasant occasion.

**Optical Illusion.**

One often sees a curious thing when looking at a moving picture of a train in motion. If the train is moving slowly the connecting and side rods and the swing of the counterweight show that the driving wheels are revolving, but the spokes if looked at alone seem to be either quite still or are even moving in the opposite direction to that of the movement of the train. If the picture shows a vehicle in motion where there is nothing to show that the wheel revolves except the flash of light on the spokes the stationary effect may be more pronounced and this curious appearance may once in a while be noticed by the observant spectator.

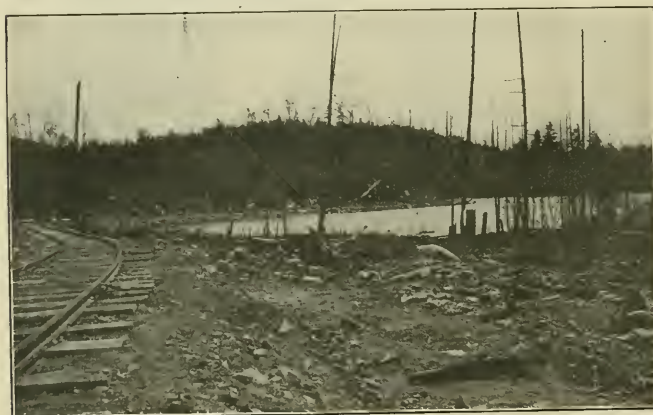

32-IN. GAUGE ROAD WITH FIVE PER CENT. GRADE BETWEEN LAKES, LAKE OF BAYS RAILWAY, ONTARIO.

part of the city of Chicago, stopping at the Art Institute, Field's Museum, located in Jackson Park, where a photograph of the party was taken, after which they visited Amusement Park, known as the White City. Tables were laid for the entire number and a banquet was served, after which each one was provided with the necessary tickets to enable him or her to enjoy every attraction and novel sight in the "White City," and about midnight they all returned to their hotels in automobiles provided by their hosts. The Chicago Pneumatic Company intend to commemorate this feature of the visit of the Boiler Makers' Association by issuing an official booklet in which will be shown the names of those who attended and a reproduction of the group at the Field Museum, and the scene in the banquet hall at the White City. A copy of this booklet will be sent to each member of the Association and to other

It occasionally happens in these pictures that the wheels of a hansom cab or a fire engine or other vehicle look as if they were revolving backward, when the vehicle is advancing rapidly. That this is not a defect in the wonderful projecting machine, may be known from the fact that a spoked car wheel, if viewed by the light of a series of equally spaced lightning flashes, would present the same appearance. The explanation is that the photographing apparatus which takes the negatives for moving pictures does so at regularly spaced intervals of time. Suppose the wheel spokes to stand in the position indicated by the figures on a clock dial, when No. 1 picture was taken, and suppose that they all advance a distance exactly equal to the five-minute space when No. 2 picture was taken, and so on, all around the clock. It is obvious in this case that the wheel would not appear

**Locomotive Blow-Off Plug Valves**

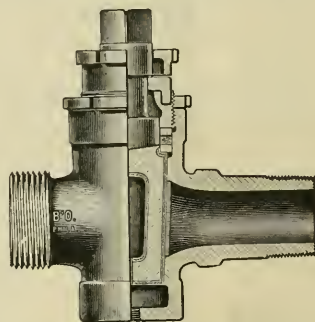

Fig. 9.

All Brass, extra heavy, with Cased Plug. For 250 lbs. pressure.

Made with Draining Plug to prevent freezing.

**Locomotive Gauge Cocks**

For High Pressure

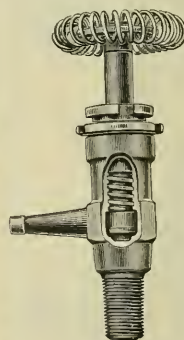

Fig 23, with Wheel.

Bordo Self-Grinding Gauge Cocks, made with renewable Hard Bronze Disc. Opened and closed with a quarter turn. Guaranteed Steam tight under the most exacting conditions. Shanks Threaded to specifications for Locomotives.

**Swing-Joints and Pipe Attachment**



Fig. 33.

May be applied between Locomotive and Tender.

These Swing-Joints are suitable for Steam, Gas, Air, Water or Oil.

Complete Booklet on Application

**L. J. BORDO CO.**  
PHILADELPHIA, PA.



# Tate Flexible Staybolt

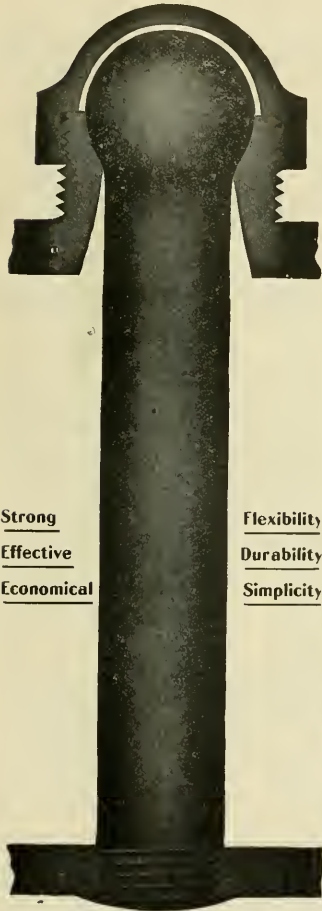

Strong  
Effective  
Economical

Flexibility  
Durability  
Simplicity

Holds firebox sheets securely together, and accommodates itself to the unequal expansion of the plates.

## FLANNERY BOLT COMPANY

PITTSBURG, PA., U. S. A.

Suite 308, Frick Bldg.

B. E. D. STAFFORD, - - General Manager

Write us for Reference Book

to revolve at all. If, however, with same time intervals, the 12 o'clock spoke moved over only four minutes' space, and all the others covered the same distance, and were photographed in that position, and if at the next exposure the 12 o'clock spoke stood at 8 minutes past, with all others having made a similar advance, we would apparently behold the strange spectacle of a wheel turning slowly on a rapidly driven vehicle and revolving in a direction opposite to that in which we see it is moving. The same appearance may be observed with the spoked wheels of an electrically driven street car when a series of regularly spaced flashes leap out between wheel and rail. It is a curious illusion, but its explanation is simple enough.

The Quincy, Manchester, Sargent Company, of New York, have issued a catalogue in extensible book form. By

creates the Railway Appliances Company, the Q. & C. Company and the Pedrick & Ayer Company have their New York offices at 114 Liberty street, New York, and they will be happy to forward one of these seven-fold catalogues to anyone interested enough to apply to them for one.

### Change of Name.

The Brotherhood of Locomotive Firemen, at a meeting recently held in Milwaukee, Wis., decided to change the name of their organization from "Brotherhood of Locomotive Firemen" to that of "The Brotherhood of Locomotive Firemen and Enginemen." About 20 per cent. are road engineers; 6 per cent., yard engineers; and 2½ per cent. are hostlers and engine dispatchers.

### Great Eastern Six-Wheeler.

Our illustration shows the six-wheel engine formerly used in suburban traffic on the Great Eastern Railway of

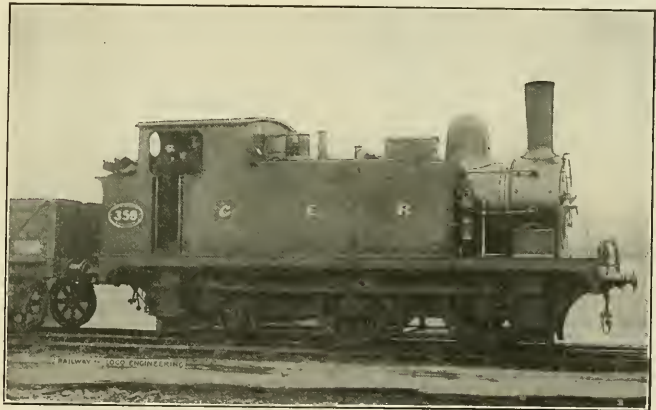

GREAT EASTERN RAILWAY OF ENGLAND, SIX COUPLED TANK ENGINE.

that we mean that the catalogue has stiff cloth covers between which there are seven catalogues held in place by a pair of neat button-head thumb screws. This makes the collection like a committee with power to add to their number, and each new addition to the work can be secured in place along with the rest. The first of these catalogue sections deals with the well known Pedrick & Ayer Co.'s products. The next deals with the Q. & C. metal sawing machines; this is followed by the Q. & C. portable rail saws and power hack saws. After this comes the Pedrick & Ayer portable tools for the repair shop. Succeeding this is Pneumatic Cranes and hoists; Riveting Machinery, and lastly the car and engine department in which is presented a number of devices for use in the mechanical and operating departments of steam roads. This company, which now op-

England. This engine was superseded some time ago by a heavy decapod designed by Mr. James Holden, locomotive superintendent of the line. The decapod combined high tractive power with the ability to start quickly and get up to speed rapidly.

The six-wheeler here shown weighs in working order 42 tons 9 cwt. The cylinders are 16½x22 ins. The heating surface of the tubes is 901.4 sq. ft.; that of the fire box is 86.77, making a total of 988.17 sq. ft. The grate area is 14.5 sq. ft. The heating surface is, therefore, 5.9 times the grate area. There are 225 tubes, each 1½ ins. outside diameter. The boiler is 4 ft. 2 ins. diameter and carries a pressure of 180 lbs. The wheel base is 13 ft. 10 ins., and the capacity of the tanks are in all 1,200 Imperial gallons. The hinged receptacle on top of the boiler is a tool-box.

**CYLINDER BORING BARS**

**VALVE SEAT ROTARY PLANING MACHINES**

**CRANK PIN TURNING MACHINES**

*Write for Catalog*

**QUINCY, MANCHESTER, SARGENT CO.**  
 OLD COLONY BLDG. 114 LIBERTY ST. CHICAGO NEW YORK  
 MACHINERY SALES DEPT. PLAINFIELD, N. J.

**SKAT**

is a soft soap sold in a neat lithographed can. When you wash up with SKAT, it gets into the crannies and "hard to reach" corners of your hands and the results are surprising. That's where the dirt lurks and hard soaps won't go. That's why SKAT is so popular. SKAT is made of the best materials, is absolutely pure and guaranteed to give you perfect satisfaction. You'll use it every day and like it more each time.

We can tell you where to buy SKAT, or better still show you how to sell it. If SKAT is out for sale in your locality, let us give you the selling right. Drop us a postal and get a free sample.

**SKAT MFG. COMPANY**  
 Hartford Conn.

**A Practically Perfect Portable Pneumatic**

**PUNCH**

Stop moving your heavy work to the machine. One Man brings this tool to the work and punches it besides.

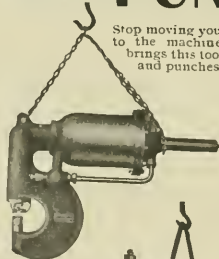

Punch Size 8

**SAVES TIME LABOR SPACE**

Leading concerns in all parts of the country use this Punch.

Built in 5 Standard Sizes. Special machines built to order. Write for Catalogue C.

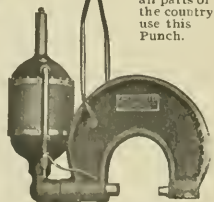

**F. F. SLOCOMB & CO., Builders**  
 WILMINGTON, DEL.

**Adjustable Bushings.**

The Bard Adjustable Bushing for Armstrong Die Stocks, made by the Armstrong Manufacturing Company, of Bridgeport, Conn., is a trouble-saving affair. It is made in four sizes, each size taking the same range of pipes as the corresponding number of the stock. This bushing as shown in our illustration, consists of a malleable iron body having a sleeve fitting into the barrel of the stock.

A turn of the cam-plate brings a set of jaws firmly against the pipe, center-

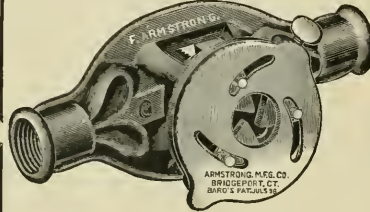

**BARD ADJUSTABLE BUSHING.**

ing it at the same time. The cam-plate is then secured by a thumb screw, thus insuring an accurate and straight thread. When a crooked thread is desired it can be cut.

The arrangement is more reliable than the wrapping of paper or tin around the pipe when the exact size bushing cannot be found. The tool need not be removed from the stock after fitting and has nothing in its make-up to get out of order.

A complete 48 page catalogue of machines and pipefitters' tools and specialties will be sent to anyone interested who writes direct to the Armstrong Manufacturing Company, Bridgeport, Conn.

The Baldwin Locomotive Works has issued a neat little pamphlet, Record No. 58, uniform with their other publications.

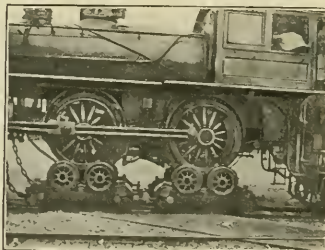

**HOLMAN DRIVING WHEELS, UP IN THE AIR.**

It contains a description of the ceremonies at the unveiling of the statue of M. W. Baldwin, the founder of the Baldwin Works. The pamphlet is beautifully illustrated and will be sent to those who write to the firm for a copy. Address Burnham, Williams & Co., Philadelphia.

**Colored Locomotive Pictures**

Send 15c. for sample picture (size 3 1/4 x 7 inches) representing an old wood burning passenger locomotive. This picture shows the bright colors that were used to decorate the engines of fifty years ago.

**FRANK BIRD, 1921 Monument Ave., Philadelphia, Pa.**

**THE UNION SWITCH & SIGNAL CO.**

**Consulting and Manufacturing Signal Engineers**

**Automatic Block Signals—Electric and Electro-Pneumatic**

**Interlocking—Electric, Electro-Pneumatic and Mechanical**

**Electric Train Staff Apparatus**

**GENERAL OFFICES AND WORKS AT SWISSVALE, PA.**

**DISTRICT OFFICES:**

**New York: 143 Liberty Street**  
**Chicago: Monadnock Block**  
**St. Louis: Frisco Building**

**DIRECTORY OF RAILWAYS OF THE WORLD**

The Universal Directory of Railway Officials, published in London, contains a list of the entire railroads of the world, with physical particulars and names of all officials.

**Send Your Order Now**  
 for the 1906 edition.

**Price \$3.00 Prepaid**

**A. FENTON WALKER**  
 Sole Representative for U. S.  
 143 Liberty Street NEW YORK

# The Best and Cheapest Books for Railroad Men

**AIR BRAKE CATECHISM** **Price, \$2.00**

By Robert H. Blackall. 20th Edition. Contains 1500 Questions and their Answers on the Westinghouse Air Brake, which are strictly up-to-date. Includes two large Westinghouse Air Brake Educational Charts printed in colors. Gives the necessary information to enable a railroad man to pass a thoroughly satisfactory examination on the subject of Air Brakes. The author's many years' experience as Air Brake Inspector and Instructor enables him to know at once how to treat the subject in a plain, practical manner. Endorsed and used by Air Brake Instructors and Examiners on nearly every railroad in the United States. The standard and only complete work on the subject. 312 pages.

**LOCOMOTIVE BREAKDOWNS AND THEIR REMEDIES** **Price, \$1.50**

By Geo. L. Fowler. Just issued. Tells how and what to do in case of an accident or breakdown on the road; includes special chapters on Compound Locomotives. Better procure a copy, as it contains 800 Questions and their Answers on Accidents and Breakdowns.

**LOCOMOTIVE CATECHISM** **Price, \$2.00**

By Robert Grimshaw. 23d Edition. Is right up-to-date and contains twelve large Folding Plates and 1600 Questions and Answers on How to Run a Locomotive. The Standard Book on the subject, being written in plain language and free from mathematical formulae and complex problems.

**NEW YORK AIR BRAKE CATECHISM** **Price, \$1.00**

By Robert H. Blackall. The only complete treatise on the New York Air Brake and Air Signaling Apparatus, giving a detailed description of all the parts, their operation, troubles, and the methods of locating and remedying the same. 250 pages.

**COMBUSTION OF COAL AND THE PREVENTION OF SMOKE** **Price, \$1.50**

By Wm. M. Berr. Contains over 800 Questions and their Answers on the Science of Steam Making.

**AIR BRAKE CHARTS** **50c.**

Showing the Westinghouse Equipment in ten colors, including freight and passenger engine. Every railroad man should possess these charts at this low price.

**A Special Circular** of any of these books sent on request. Any of these books sent prepaid on receipt of price.

**Agents Wanted at Every Terminal.** Write for our special terms. You can make equal to a month's pay selling our books on the side

**The Norman W. Henley Pub. Co.**

132 Nassau Street, New York, U. S. A.

Students and friends of the International Correspondence Schools will be interested in the celebration of the fifteenth anniversary of the schools, which is to be held in Scranton on October 16. The day will be taken up with appropriate exercises and an interesting exhibit of the schools at work preparing and printing home-study text-books and correcting the recitations of students will be given. A banquet to the guests by the schools will follow in the evening.

It has been announced by Hon. H. R. Emerson, Canadian minister of Railways and Canals that it is the intention of the Dominion government to purchase, in the near future, several branch railways in the province of New Brunswick, which connect with the Intercolonial railway, which is a government road. These smaller lines are tributaries to the Intercolonial and the intention of the government is to include them in the provincial railway system.



HOLMAN ENGINE, BELL APPEARS TO WORK WELL.

The Railway Signal Association will hold their annual meeting in Chicago on October 16, 17 and 18, instead of 8th, 9th and 10th, as previously arranged. The headquarters of the association will be the Great Northern Hotel. It is expected that the exhibits of signal apparatus and supplies will be very extensive and a large attendance of members is expected.

The Quincy, Manchester, Sargent Company, of Chicago, announce the opening of their Priest Snow Flanger Department. Among the orders already booked for the season's delivery are 22 flangers for Canada, also orders for Japan, Alaska and the Continent. From the orders and reservations already received a busy season in this department is assured.

Last month we had occasion to make mention of a very useful little book. The Car Interchange Manual, compiled by Mr. J. D. McAlpine, of the Lake

# One Year and Eleven Months' SERVICE

WITHOUT REPACKING, ON

## HIGH-PRESSURE LOCOMOTIVES

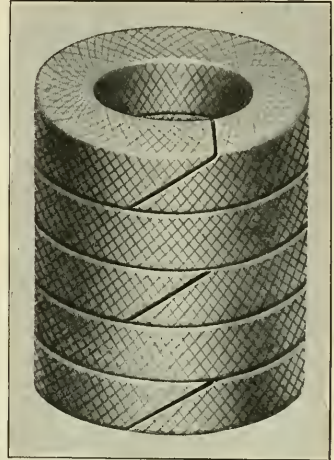

Style 300 TV.

A throttle failure is an absolute impossibility where Crandall's Throttle Valve packing is used.

IT WILL NOT BLOW OUT

## Crandall Packing Co.

FACTORY AND GENERAL OFFICE

**PALMYRA, - NEW YORK**

BRANCHES  
 New York 136 Liberty St. Cleveland 9 So. Water St.  
 Chicago 52 West Washington St.

# Patents.

**GEO. P. WHITTLESEY**  
 McGILL BUILDING WASHINGTON, D. C.  
 Terms Reasonable. Pamphlet Sent

## Molding Machines

Vertical Vibration. Power Draft  
**ALL KINDS OF MACHINES**

**THE E. H. MUMFORD CO.**  
 17th & Callowhill Streets, PHILADELPHIA, PA.  
 J. W. JACKMAN & CO., Ltd., 59 Victoria St. London, S. W.

# World's Fair

St. Louis

FIRST PRIZE FOR

# TOOL STEEL

AWARDED TO

McInnes Steel Co.

CORRY, PA.

in competition with the best makes in England and Germany. Also manufacturers of all kinds of Tool Steel, Die Blocks, and Steel Forgings.

Write for Prices and Information

STANDARD MECHANICAL BOOKS  
FOR ROAD AND SHOP MEN  
BY CHAS. McSHANE

The  
Locomotive Up to Date

Price, \$2.50

New York and  
Westinghouse Air Brakes

Price, \$1.50

One Thousand Pointers for  
Machinists and Engineers

Price, \$1.50

All books bound in fine cloth

AGENTS WANTED everywhere; write for terms and descriptive circulars. Will be sent prepaid to any address upon receipt of price.

GRIFFIN & WINTERS  
171 La Salle Street, CHICAGO

Shore road. The book is issued by the McConway and Torley Company, of Pittsburgh, makers of the Janney, Pitt and Kelso couplers, etc. The book will be sent free by that company to any one who will apply to them for a copy.

Owing to increased business the Hicks Locomotive and Car Works announce the removal of their general offices to the seventeenth floor of the Fisher Building, Chicago, Ill. Their telephone (Harrison 3949) will remain the same, with private exchange to all departments and long distance service.

The tendency of modern steam plants to use higher steam pressures than heretofore has called for a better class of steam packings than has hitherto been necessary. Packings made of Asbestos fiber have been found to meet all the requirements of this service. The well-known firm of H. W. Johns-Manville Co., of New York, have achieved success with their line of "J.-M." Asbestos Packings, as these are made in various forms to

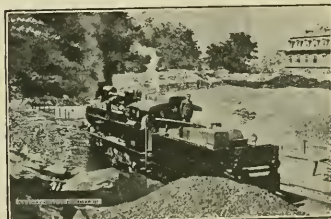

IN THE TYROL—LANDECK, AUSTRIA.

meet various conditions. These packings possess high heat-resisting properties, are durable and do not readily harden or blow out. No rubber or organic materials are used in their make-up and they will withstand any ordinary degree of temperature or pressure. They are pliable and will readily conform to irregular surfaces. The company have issued an attractive catalogue showing their complete line of "J.-M." Asbestos Packings and we understand that copies of this will be mailed free upon request.

The story is told of an Irishman who, on being informed of the enormous cost of construction of a very large and beautiful church in one of our cities, exclaimed, "Well, doesn't that beat the devil?" To which his informant promptly replied, "That is the intention of the building." When you speak of heating a refrigerator car, does it not seem like a contradiction, on account of the name of that kind of car? Well, like the gentleman from Erin, you must remember the intention of the

This illustration shows the form of construction of the  
**Dart Patent Union**

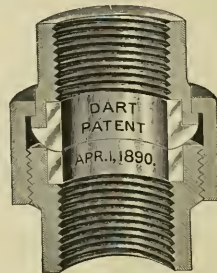

Every feature of construction represents the best points to insure stability and durability. The malleable iron pipe ends and nuts, in combination with bronze metal seats, are as near perfection as is possible to approach, and the sales to date indicate the public approval. There are none so good. For sale by all the principal jobbers in United States, Canada and Europe.

E. M. Dart Mfg. Co., Providence, R. I.  
FAIRBANKS CO., SALES AGENTS.



## The Twentieth Century Master Mechanic

Won't use Solid Mandrels.  
Cost too much, take up too  
much room and don't give  
satisfaction.

### Nicholson Expanding Mandrels

Take everything from 1 to 7  
inch holes. Take up little  
room — always ready and  
you can buy four sets for  
the cost of one of the solid  
kind

Are You Using Them?

Catalogue tells you  
more about them.

W. H. Nicholson & Co.  
Wilkesbarre, Pa.

# Locomotives, Freight and Passenger Cars

## New Flats, Box and Gondola Cars

of any capacity for immediate delivery. Locomotives of all weights and types

Shops at **Hammond, Indiana**  
**Dover, New Jersey**

Cable Address  
"FITZLUTH"

Export Shipments  
a Specialty

**FITZ-HUGH, LUTHER CO., Monadnock Block, CHICAGO**  
141 BROADWAY NEW YORK    CHEMICAL BLDG. ST. LOUIS    80 ST. FRANCIS XAVIER ST. MONTREAL, CAN.    RIALTO BLDG. SAN FRANCISCO

vehicle. A refrigerator car is intended primarily to keep things cool, not necessarily to freeze them, and a proper refrigerating system is provided for that purpose. The walls, sides and top of the car are made of insulating material, so as to keep the heat of the atmosphere outside, from reaching the inside of the car. When the inside of the car is cool, the insulation helps to keep it cool by preventing the transference of heat. That is the point—the non-transference of heat. Now, when it comes about that there is freezing weather outside, the walls of the car keep heat inside as effectually as they kept it out when the weather was hot. For the transportation of perishable freight, like fruit, vegetables, etc., the warm car, if it can retain its heat effectually and at low cost, is the car which that kind of traffic demands, and the warmed refrigerator, is the car for the business. The Gold Car Heating & Lighting Company, of New York, have lately issued a folder dealing with their improved storage system for heating refrigerator cars, and in that folder they tell how the work is done and how the steam heat arrangement which is usually employed to keep passengers warm can be turned to account to keep perishable merchandise, like fruit, in prime condition. They make use of the fact that the insulated car will not transfer heat in or out, whether you call it a refrigerator car or not, and in this they show that they know the intention of the car structure. Write to them at the Whitehall Building, New York, if you would like a copy of the circular.

The Ekert High Resistance Materials Company, of Dayton, Ohio, point out, in a circular just received, that asbestos has always been recognized as a steam resisting material of high quality, and in order to make it thoroughly non-porous it is produced by this company under a patented process. The Ekert

disc and packing is dense and does not absorb water, so that the tendency to decompose or rot is thus checked. Another point to which the manufacturers have given attention is the elasticity and the perfect fibrous body of the prepared asbestos. This, they say, is accomplished by combination with high resisting pore-filling materials in any desirable or requisite quantity. Write direct to the company for descriptive circular.

The Armstrong Bros. Tool Co., "The Tool Holder People," of Chicago, report that the summer months have kept their plant working at its extreme limit to keep abreast of orders, and they have been forced to install additional machinery in an effort to get some finished stock ahead. September business has opened with a rush, dealers' orders, both domestic and foreign, being especially heavy, they evidently anticipating heavy demand and delayed shipment. Sales of Armstrong Cutting-Off and Grinding Machines are increasing steadily. Among recent orders received: Schuchardt & Schutte, Vienna, 4 machines; Manning, Maxwell & Moore, New York, 2 machines; Manning, Maxwell & Moore, Chicago, 1 machine.

Forests of leafless trees may be met with in some parts of Australia. They respire through a little stem which apparently answers the same purpose as a leaf. The tree is known as "the leafless acacia."

A cyclone is a circular storm, or system of winds, varying from 50 to 500 miles in diameter, revolving round a center that may advance 40 miles in an hour.

Success is the real golden calf of modern life and there are few people who refuse to fall down and worship it.

### METAL PRESERVATIVE PAINTS AND PRIMER

for locomotives, boilers, stacks, front-ends, gearing, frame-work, metal roofs, etc.  
Tell us your needs.  
Metal preservative paints have been our specialty for 22 years.  
Paints for all conditions.

THE  
**STANDARD PAINT CO.**  
Sole Manufacturers  
100 William St., New York  
CHICAGO      ST. LOUIS

### CONTENTS:

	PAGE.
*Railway Steamship .....	445
Case Hardening Wrought Iron .....	447
Shifting Winds and Cooler—Subway Ventilation .....	450
*Lubricator Guard, Mo. Pac. ....	452
*General Correspondence .....	453
Traveling Engineers' Convention .....	456
Book Notices .....	462
*Shop Sully .....	463
Correspondence School, Our .....	465
Questions Answered .....	467
*Air Brake Department .....	469
*Patent Office Department .....	471
Personals .....	472
Exhibits, Trav. Eng.' Ass'n. ....	480
*Wheel Press, Hydraulic .....	483
Optical Illusion .....	484
Locomotives—	
*Northern Pacific 4-6-2 .....	448
*Old Timer on the Grand Trunk .....	459
*Water-Tub Locomotive Boiler .....	463
*Baldwin Mallet Compound, Gt. Nor. ....	473
*Tank Engine, Northern of France .....	479
*Great Eastern Six-Wheel Engine .....	485
Cars—	
*Gasoline Windsplitter, Union Pac. ....	459
*Fifty-ton Trolley Wagon, N.-E. of England .....	464
Editorials—	
Traveling Engineers' Convention .....	460
Transportation Factor of Safety .....	460
Apprentice Machinists .....	461
Westward for the Far East .....	461
Railroad Ties and Spikes .....	462

The **Targant Glove** TRADE MARK



"WRIST OR GAUNTLET"

**TRY THEM**

They are made for hard wear from the very best grade of chrome tanned horsehide leather. Heat and water proof. No rivets nor in seams to hurt the hands.

If your dealer does not carry "Sargents" we will sell you direct on receipt of your size and \$1.00

Write for free leather match safe and descriptive booklets

DETROIT LEATHER SPECIALTY COMPANY, -- Detroit, Mich.

**TALMAGE SYSTEM**

A MECHANICAL SYSTEM FOR LOCOMOTIVES THAT OVERCOMES THE BAD EFFECTS FROM THE USE OF UNDESIRABLE FEED WATERS

PATENTED IN UNITED STATES AND FOREIGN COUNTRIES

**RUBRA BOILER OIL  
TALMAGE BLOW OFF VALVES**

USED IN CONNECTION

**GUARANTEE**

WE GUARANTEE TEN TIMES GREATER MILEAGE BETWEEN BOILER WASHINGS AND TO REDUCE MOTIVE POWER EXPENSES SUFFICIENT TO MAKE THE COST OF OUR SYSTEM PERMISSABLE.

THE TALMAGE MANUFACTURING COMPANY  
CLEVELAND, O., U.S.A.

J. G. TALMAGE, President

**INDEX TO ADVERTISEMENTS.**

Acme Machinery Co. . . . .	Front Cover
Air Brake Chart . . . . .	4th Cover
Ajax Metal Co. . . . .	4th Cover
Aldon Co. . . . .	15
American Balance & Co. . . . .	4th Cover
American Brake Shoe Co. . . . .	15
American Loco Sander Co. . . . .	483
American Locomotive Co. . . . .	8
American Locomotive Equipment Co. . . . .	4th Cover
American Valve and Meter Co. . . . .	2d Cover
Armstrong Bros. Tool Co. . . . .	2d Cover
Armstrong Mfg. Co. . . . .	24
Audel, Theo. Co. . . . .	8
Baker, Wm. C. Heating and Supply Co. . . . .	—
Baldwin Locomotive Works . . . . .	10
Ball Webb, C. Co. . . . .	24
Barnett, G. & H. Co. . . . .	2d Cover
Barrett Machine Tool Co. . . . .	—
Bettendorf Axle Co. . . . .	9
Big Four Railroad . . . . .	486
Bird, Frank . . . . .	486
<b>BOOKS:—</b>	
Air Brake Chart . . . . .	—
Compound Locomotives . . . . .	25
Computers . . . . .	25
Conger's Air Brake Catechism . . . . .	26
Firing Locomotives . . . . .	9
Locomotives Running and Management . . . . .	9
Machine Shop Arithmetic . . . . .	20
Miscellaneous . . . . .	20
Oil Burning in Locomotives . . . . .	18
Train Rules and Train Dispatching . . . . .	8
Twentieth Century Locomotives . . . . .	8
Bordo, L. J. Co. . . . .	484
Boston & Maine R. R. . . . .	17
Carpenter, The J. M., Tap & Die Co. . . . .	17
Central R. R. of New Jersey . . . . .	7-9
Chalfonte Hotel . . . . .	1
Chapman Jack Co. . . . .	1
<b>CHARTS:—</b>	
Combination Passenger & Sleeping Car . . . . .	12
Locomotive, Atlantic Type . . . . .	1
Locomotive, American Type . . . . .	9
Chicago Car Heating Co. . . . .	13
Chicago Pneumatic Tool Co. . . . .	16
Chicago & Alton R. R. . . . .	18
Cleveland City Forge & Iron Co. . . . .	4th Cover
Cleveland Twist Drill Co. . . . .	4th Cover
Climax Bearing Co. . . . .	8
Commercial Acetylene . . . . .	24
Commonwealth Steel Co. . . . .	3
Consolidated Railway, Electric Lighting & Equipment Co. . . . .	8
Crandall Packing Co. . . . .	489
Dart, E. M., Mfg. Co. . . . .	488

Davis, John Co. . . . .	23
Detroit Leather Specialty Co. . . . .	490
Detroit Lubricator Co. . . . .	13
Detroit Seamless Tube Co. . . . .	21
Dixon, Joseph, Crucible Co. . . . .	3
Expanded Metal Co. . . . .	14
Falls Hollow Staybolt Co. . . . .	480
Fay & Egan Co., J. A. . . . .	11
Fitz Hugh Lather Co. . . . .	11
Flanders, L. B., Machine Works . . . . .	11
Flannery Bolt Co. . . . .	485
Franklin Mfg. Co. . . . .	2
Galena Signal Oil Co. . . . .	18
Garlock Packing Co. . . . .	19
General Electric Co. . . . .	482
Gold Car Heating Co. . . . .	18
Gould Coupler Co. . . . .	18
Gould Coupler Co. . . . .	18
Hancock Inspirator Co. . . . .	488
Griffin & Winters . . . . .	4th Cover
Hammett, H. G. . . . .	—
Hendrick Inspirator Co. . . . .	18
Hendrick Mfg. Co. . . . .	18
Henley & Co. . . . .	487
Hicks, F. M., & Co. . . . .	18
Hoffman, Geo. W. . . . .	18
Homestead Valve Mfg. Co. . . . .	483
Hunt, Robert W., & Co. . . . .	483
Illinois Central R. R. . . . .	26
International Correspondence Schools . . . . .	9
Jenkins Bros . . . . .	4th Cover
Johns-Manville, H. W. Co. . . . .	481
Kennicott Water Softener Co. . . . .	3d Cover
King-Lawson Car Co. . . . .	2d Cover
Kimwear Mfg. Co. . . . .	17
Lackawanna R. R. . . . .	17
Lake Shore . . . . .	—
Latrobe Steel Co. . . . .	8
Latrobe Steel & Coupler Co. . . . .	8
Lexington Hotel . . . . .	7
Locomotive Charts:—	
Atlantic Type . . . . .	1
Locomotive Publishing Co., Ltd. . . . .	16
Long & Allister Co. . . . .	17
Magnus Metal Co. . . . .	4
Manning, Maxwell & Moore . . . . .	22
McConway & Torley Co. . . . .	11
McCord & Co. . . . .	2d Cover
McLachlan Mfg. Co. . . . .	488
Norse Twist Drill Co. . . . .	16
Mumford The E. H., Co. . . . .	487
Munn & Co. . . . .	14
Nathan Mfg. Co. . . . .	14
National Acme Mfg. Co. . . . .	5
National Malleable Castings Co. . . . .	4th Cover
New Jersey Asbestos Co. . . . .	19 and 26
New York Central R. R. . . . .	488
Nicholson W. H., & Co. . . . .	488
Niles-Bement-Pond Co. . . . .	3
Norton Grinding Co. . . . .	14
Norwalk Iron Works . . . . .	18
Pacific Trading Co. . . . .	2
Pennsylvania R. R. . . . .	3
Pittsburgh Spring & Steel Co. . . . .	17
Porter, H. K., & Co. . . . .	3
Pratt & Whitney . . . . .	3
Pressed Steel Car Co. . . . .	10
Prosser, Thos., & Son . . . . .	16
Quincy, Manchester Sargent Co. . . . .	2d Cover
Railway Materials Co. . . . .	486
Railway Steel Spring Co. . . . .	10
Ralston Car Co. . . . .	4
Reverse Rubber Co. . . . .	3d Cover
Rogers, H. A., Co. . . . .	2
Rogers Locomotive Works . . . . .	17
Rue Mfg. Co. . . . .	18
Safety Car Heating & Lighting Co. . . . .	11
Saunders, D., Sons . . . . .	14
Scandinavia Belting . . . . .	15
Sellers, Wm., & Co., Inc. . . . .	2
Sight Feed Oil Pump Co. . . . .	486
Slat Mfg. Co. . . . .	486
Slocumb, F. P., & Co. . . . .	486
Smooth-On Mfg. Co. . . . .	16
Southern Pacific R. R. . . . .	2d Cover
Standard Car Truck Co. . . . .	15
Standard Coupler Co. . . . .	15
Standard Paint Co. . . . .	10
Standard Steel Works . . . . .	21
St. Louis Car Co. . . . .	13
Star Brass Mfg. Co. . . . .	19
Starrett Co., L. S. . . . .	488
Storrs Mica Co. . . . .	7
Symington, T. H., & Co. . . . .	19
Swift Paint Co. . . . .	4
Tabor Mfg. Co. . . . .	490
Talmage Mfg. Co. . . . .	11
Underwood, H. B., & Co. . . . .	7
Union Pacific R. R. . . . .	486
Union Switch & Signal Co. . . . .	23
United States Metallic Packing Co. . . . .	25
Utica Steam Gauge Co. . . . .	13
Vacuum Cleaner Co. . . . .	10
Van Duzen Co. . . . .	10
Valcan Iron Works . . . . .	486
Walker, A., Fenton . . . . .	4th Cover
Walworth Mfg. Co. . . . .	2d Cover
Warshaw Co. . . . .	4th Cover
Watson-Stallman Co. . . . .	6
Westinghouse Air Brake Co. . . . .	7
Westinghouse Electric & Mfg. Co. . . . .	22
Whiting Foundry Equipment Co. . . . .	487
Whitlessy, Geo. P. . . . .	7
Williams Typewriter Co. . . . .	14
Wood, R. D., & Co. . . . .	7
Zephon Chemical Compound Co. . . . .	15

# Railway and Locomotive Engineering

Copyright by Angus Sinclair Co.—1906

A Practical Journal of Railway Motive Power and Rolling Stock

Vol. XIX.

136 Liberty Street, New York, November, 1906

No. 11

## Concrete Viaduct.

The Santa Ana arched viaduct crossing the Santa Ana river five miles west of Riverside, Cal., on the San Pedro, Los Angeles & Salt Lake Railroad, is a concrete structure 984 ft. long, 17 ft. wide, and having an average height of 55 ft. It contains about 14,000 cu. yds. of concrete.

The main arches, eight in number,

which are 9 by 21 ft., and are penetrated vertically by two wells 2.5 by 5 ft., thus saving material and providing a complete drainage system by means of weep holes at the bottom of the wells, and horizontal tunnels at the top of each arch haunch.

The outer spandril walls are 3 ft. thick, rising 2.25 ft. above the crown of the arch, and surmounted by a 15 in.

tils, and a 5 ft. parapet wall forming a refuge bay on each side of the bridge at each pier. The approaches are double retaining walls connecting with the abutment piers by a 38.5 ft. arch of similar construction to that of the larger arches. The retaining walls are relieved by pilasters at either end, the second pilaster acting as the shore pier for the small arch.



CONCRETE VIADUCT OVER THE SANTA ANA RIVER, IN CALIFORNIA

with 100-ft. centers, are circular, having a radius of 43.5 ft., and a rise of 36.9 ft. from the spring to the crown of the arch. The arch ring is six inches wider than the spandril walls, and has an upper radius of 50 ft., being 42 ins. thick at the crown of the arch. The seven stream piers have a footing course 16 by 8 ft. Above the footing course to the water level, the piers are six inches smaller, with the corners cut off, making an octagonal form. The water tables,

coping and a 3 ft. parapet wall. There are also two inner spandril walls running from a point 17.5 ft. from the crown of the arch on each side, and at about the same elevation, with a slope of 1 to 30 to the piers. These walls are connected by a cross wall 7.5 ft. from the pier, and are covered by a 10 in. concrete floor sustaining the ballast, which is 3.5 ft. deep at the crown of the arch. The piers are surmounted by a coping supported by brackets or den-

The construction of the bridge was carried out by Messrs. the E. B. & A. L. Stone Company, of Oakland, Cal. Work was begun the latter part of October, 1902, on the excavations for the foundation of the east abutment pier, where the bedrock stands vertical, occupying half the space of the pier and an outcropping above the surface in the form of huge boulders. The stream side of the pier extends 22 ft. below the surface of the river bottom. Sheet piling was

driven to bedrock, and the material to be excavated, sand, gravel and occasional layers of silt, was taken out by means of centrifugal dredge pumps. Seepage from underground sources furnished a sufficient quantity of water to supply the pumps. At the west appro-

ach, the washer to the top of the bank at the west approach, where the mixing plant was installed. This plant consisted of bunkers and a battery of three Ransome mixers placed in line, driven by a 25 h.p. horizontal engine. A straight trackway ran the entire length

of the nearest railway point being five miles from the work. The work has progressed steadily, about 200 men being employed, and it is now nearing completion. An interesting feature of the bridge is that no steel nor stone masonry was used in construction, it being a concrete structure entirely, and probably the largest of its kind in the world.



CANADIAN PACIFIC SHOPS AT WINNIPEG, MAN.

ment pier the bedrock sloped at an angle of about 45 degrees toward the bed of the river. This was hewed into horizontal steps, making a firm and secure foundation for the pier. At the stream piers bedrock was reached by this method with comparatively little difficulty at a varying depth of from 14 to 36 ft.

Local cement and gravel were used in the foundations, piers and spandril walls in the proportions of 1 to 11. It was first intended to utilize the fine gravel in the river bed, but a large deposit of better gravel was discovered above water level in the west bank of

of the bridge, and a double drum cableway, driven by the mixer engine, conveyed a train of cars to and from the mixers. The concrete was dumped through chutes from the trackway to the point where it was put in place.

Foreign cement, sand and crushed rock were used in the arch rings in the proportions of 1, 2, and 4½. The arch centering was supported on 4 bents of 4 round piles each, driven to bedrock. These were cut off and capped by 12x12 timber; 12x12 stringers were placed horizontally on these caps. The thrust from the segments was conveyed by 8x8 struts to horizontal chords, which

#### Railway Shops on the Prairie.

The Canadian Pacific Railway Company's new shops at Winnipeg, Man., are for repair work only and are situated about 2½ miles west of the station on the main line, and the area of the ground fenced in is about 160 acres. There is a complete local fire alarm system connecting with the power house and the City of Winnipeg fire alarm system. There are about twelve miles of tracks, four miles of water pipes and about two miles of drains in the grounds. The shops have been laid out with a view to future extension without disturbing the existing plant.

All the buildings are of native brick on concrete foundations, they are of "Mill construction," equipped with fire sprinklers throughout. They are heated with the Sturtevant hot blast system, by means of exhaust steam from the power house. All the shops have outside lean-to buildings for lavatories and fanhouses.

Water for power and shop purposes is pumped from the Red River, about three miles east of the shops, through an eight-in. pipe into a half million gallon reservoir, and from there into an

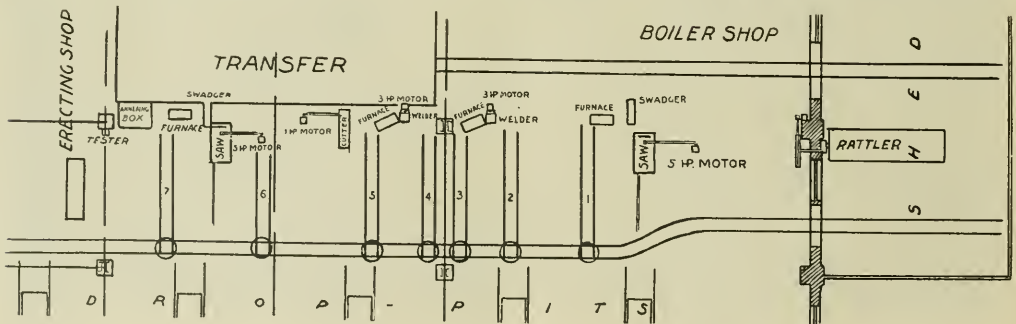

GROUND PLAN OF TUBE SHOP, CANADIAN PACIFIC RAILWAY, WINNIPEG, MAN.

the river. It was cheaper to wash this latter than to take the poorer material in the river bottom. This was done by means of a sluice, which carried water and fine gravel over a box, where the coarser sand and gravel settled. The material to be used was conveyed to a bunker by means of a bucket elevator, the silt and fine sand being carried away by the water. A 3 yd. side dump car and drum hoisting engine were used to bring the sand and gravel from

in turn were upheld by wedges placed on the 12x12 stringers. This form of centering proved very stable, and was easily removed after the concrete had set.

Standard Portland cement from the new works at Napa Junction, Cal., was used in the coping and parapet walls, and was found to make a very strong concrete. Considerable delay was experienced at the outset, caused by the long haul of material and equipment,

elevated 125,000 gallon tank standing 130 ft. high. Drinking water is pumped from a 5 in. artesian well, near the power house into an elevated 10,000 gallon tank.

The power house is 125 ft. by 101 ft., and is equipped with five 250 h.p. Babcock & Wilcox boilers, two fire pumps and two pumps for power and shop purposes. The pumps' capacity of 1,000 gallons per minute each, two 500 K. W. units driven by vertical



single-cylinder open type engines. There is also a 50 K. W. unit for night service. The engines are non-condensing, the exhaust steam being for heating the shops in the winter, in connection with the Sturtevant system, at five pounds pressure, the condensed water being pumped back to the apparatus, and the

north side of the locomotive shop and the erecting work is on the south side and across the east end.

Tube work is very quickly and expeditiously done on those engines which come in for that purpose, and as the Winnipeg shops are in the bad water district there is a good deal of this work

into the tube shop proper and are first placed on track 1. Here they are sawed off and swedged by an air swedger, to receive the safe end, and are then immediately placed on another car and taken to tracks 3 or 5, which serve the two welders. These are a pair of excellent power tools invented and patented by Mr. Walter Byrd, one of the company's general foremen. The welder was illustrated and described in the June, 1903, issue of RAILWAY AND LOCOMOTIVE ENGINEERING, page 286, and is spoken of in the highest terms by the officials of the road. After being welded they are placed again on cars stationed on tracks 2 or 4, and from thence are taken over to track 7, where they are cut to length and expanded to fit holes in front tube sheet. From here, while still hot, they are placed vertically in the annealing box, and after cooling are tested in the vertical water tester, which is attached to one of the shop columns, and after being tested they are laid in a rack from which point they are again taken by the traveling crane back to locomotive. Altogether the convenient arrangement of this tube shop and the systematic and rapid way work is carried out in it, is one of the features of the whole shop and never fails to strike mechanical department men from other roads who visit the plant.

The blacksmith shop is 216 ft. by 100 ft., and has a capacity of thirty-two fires and fourteen oil furnaces, and is



TUBE SHOP, CANADIAN PACIFIC RAILWAY, WINNIPEG, MAN.

engine room has a fifteen-ton hand power chain sprocket traveling crane, 46 ft. span and 25 ft. lift.

The locomotive and machine shop building is 164 ft. by 792 ft. and has a capacity for general repairs to locomotives of about twenty-five per month. It is equipped with all the latest machinery for general repair work, and has a riveting tower with a twenty ton riveting crane and five ton auxiliary hoist. There are two 7½ ton and one 21 ton three motor electric traveling cranes, each 56 ft. span and 27 ft. lift, traveling the whole length of the shop. Two 50-ton trolleys are used for stripping the locomotives and a transfer table with 52 ft. span, running for a length of 440 ft. in the center of the shop, is used for placing the locomotives and tenders on the different pits. A 70 ft. turntable is situated at the main shop entrance. The eight tracks at the east end are for light repairs to locomotives, six of the tracks having pits connecting with a drop pit. All machines are motor driven, the large machines individually, and the small ones divided into groups. All the machines are reached by narrow gauge tracks in conjunction with jib cranes which are provided for all machines requiring lifting apparatus. The machine tools are distributed so as to make each department of the shop self-supporting. The sections devoted to tender and boiler work are located on the

to do. An engine for tube renewal is headed in on one of the drop pit tracks and the tubes when taken out are carried by a traveling crane to a point



GENERAL VIEW OF THE MACHINE SHOP, CAN. PAC. RY., WINNIPEG, MAN.

where they are dropped on a push car and they are then shoved by hand to the shed where the rattler is located. After being cleaned they are again loaded on a narrow gauge push car on the opposite side of rattler and brought

equipped with eleven jib cranes with a varying capacity from one to three tons each. The tools consist of one 1,200 lb., one 700 lb., one 3,300 lb. single frame hammer; one 3,000 lb. double frame hammer, and 150 lb. and 250 lb.

automatic hammers. This shop also has sawing machines, punches, shears and bull-dozers, all motor driven and reached by narrow gauge tracks.

The foundry building is 120 ft. by 90 ft. and has a capacity of twelve tons per day. It is equipped with a three-motor  $7\frac{1}{2}$  ton traveling crane, 38 ft.

freight and passenger cars between Fort William and Calgary. All the machines are individually driven by motors. The shop is equipped with a shaving exhaust system, which carries all shavings, etc., from each machine to a tower near the power house, and from there direct to the boilers.

second vice-president, is in charge of the motive power department for Lines West of Fort William, and Mr. Grant Hall is the assistant superintendent of motive power at Winnipeg, Mr. S. J. Hungerford is superintendent of the Winnipeg shops. We are indebted to Mr. Cross for the photograph and information concerning the Prairie City Shops of the C. P. R.



BLACKSMITH SHOP, CANADIAN PACIFIC RAILWAY, WINNIPEG, MAN.

span and 20 ft. lift, a five ton jib crane with a 5 h.p. motor and controller, a 40 ft. cupola with a No. 8 Sturtevant pressure blower run by a 30 h.p. alternating current motor. The metal is poured from a two and a five ton spur geared crane ladles. There are two core ovens, one 9x16 ft. and the other  $7\frac{1}{2}$ x9 ft., and one grinder and two tumblers with a 10 h.p. motor. A two ton pneumatic elevator, 16 ft. lift, runs from the ground to the charging floor of the cupola. The brass foundry is equipped with a one-ton traveling crane, four furnaces, one tumbler and grinder.

The passenger car shop is 240 ft. by 100 ft. and has a capacity for general repairs of about twenty-five cars per month. The upholstering work is done on the gallery on the east side of the shop. An outside transfer table, 70 ft. span and 450 ft. long, serves this shop and the freight car shop. The freight car shop building is 312 ft. by 100 ft. and has a capacity for general repairs, including rebuilding, of about 70 cars per month.

The repair yards, at the east end of shops, have a capacity for light repairs of 150 cars per day. The dry kiln is a "Morton Moist air down draft kiln," has two compartments, each 85x19 ft., and has a capacity of four cars of lumber. The planing mill is 216x100 ft., and is equipped with machinery for manufacturing material for repairs to

The offices and general stores building is 252x85 ft., two stories high. The general offices for the shops are at the west end of the building, and are three stories in height. The stores building is fitted with shelving, cupboards and bins suitable to store railway supplies and sufficient to meet the requirements for all western lines, from Fort William, Ont., to Vancouver, B. C., including all the company's branches. It is also pro-

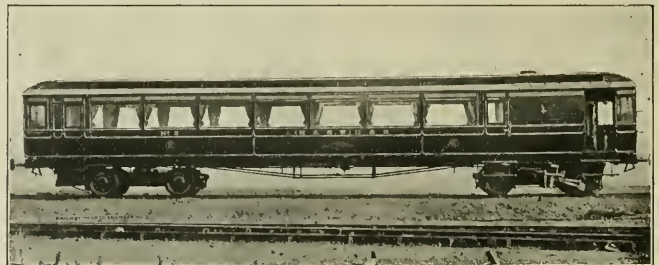

STEAM MOTOR CAR USED IN GLASGOW

vided with a two-ton hydro-pneumatic elevator and the building has a narrow gauge system of tracks connecting with all shops. There is a platform, four ft. high, all around the building, 10 ft. in width on the north and south sides, 70 ft. on the west end, and 200 ft. at the east end.

Mr. William Cross, assistant to the

be worked from either end of the carriage. In addition to the steam brake, powerful hand-brakes are fitted to both bogies. There is seating accommodation for 54 passengers. The interior of the passenger compartment is paneled with birdseye maple, finished with teak and mahogany. The seats, which are placed longitudinally,

#### New Motor Coach.

BY E. C. MOREL.

The motor coach which we illustrate has recently been put into service by the Glasgow (Scotland) Railway Company. This car is undoubtedly the finest that has yet been put upon the railway. It has a length over buffers of 64 ft. 11 ins., a width over carriage body of 8 ft. 6 ins., and height from rail to carriage roof of 12 ft. 4½ ins., and weighs, when in working order, 35 tons.

Steam is generated in a locomotive type boiler, having a working pressure of 160 lbs. per sq. in. and a total heating surface of 347 sq. ft. The fire box is fitted with Drummond water tubes. The cylinders are 9x14 ins. and are fixed on the outside of the bogie frame plates, and fitted with Welschaerts valve gear.

The water tanks, containing 350 gallons, and coal bunkers having a capacity of one ton, are placed on each side of the boiler, and are carried on the underframe of the carriage. The steam regulator and reversing gear are arranged to be worked from either end of the carriage, by means of rods and levers, so that the driver has at all times a clear look-out in the direction in which the carriage is traveling. The whistle and steam brake can also

are of plaited rush matting, over springs, and are very comfortable and easily cleaned. Ample ventilation is secured by ordinary sliding ventilators in the sides of the clerestory roof. Passengers enter through a doorway from a vestibule at the rear end and in addition, doors are placed on each side of the carriage at the end next the motor compartment, to further facilitate ingress and egress. The vestibule is fitted with steps for taking up passengers from the level of the permanent way, and there are also hinged platforms for railway stations.

The rear end driving compartment is fitted with a sliding door, so that the driver is separated from the passengers entering and leaving the carriage, while a speaking tube communicates between the driving compartment and the motor compartment, and electric bells are available for com-

#### Birmingham Southern 2-8-0.

Some time ago this road, which runs through the State of Georgia, bought some engines from the Baldwin Locomotive Works for heavy freight traffic. The cylinders of these engines are 21x26, the valves are D-slide balanced, and the driving wheels are 50 ins. in diameter. With the steam pressure carried, which is 200 lbs., the calculated tractive effort is 38,984 lbs., and with a weight of 150,360 lbs. on the drivers, the ratio of adhesion becomes 3.85.

The engine is equipped with the Stephenson link motion, and the valves are operated by indirect motion in the usual way. The pony truck carries 16,860 lbs., and it is equalized with the forward driving wheels. The practice of equalizing the pony wheels with the leading drivers alone, carries out, in theory at least, the four-wheel truck idea. In this case, however, the pony

of the flues is 2,524, giving a total of 2,719 sq. ft. The flues number 322, and are 13 ft. 4½ ins. long. The grate area is 32.6 sq. ft., and this gives a ratio of about 1 to 83 between grate area and heating surface. The crown sheet slopes up to the front in this boiler, and the steam and water space above the crown sheet is about 22 ins. in the center. The back sheet is perpendicular. The fire box back sheet slopes slightly, so as to give a slightly wider space at the top of the legs. The water space in the legs of this boiler all increase from the mud ring up, and the ogee curve of the fire box is considerable. The mud ring comes over the frames, and is about 46 ins. between centers, and the boiler is about 82 ins. across at the widest part in the cab.

The tender is of usual form, with tank carried on a steel frame. The water capacity is 5,500 U. S. gallons,

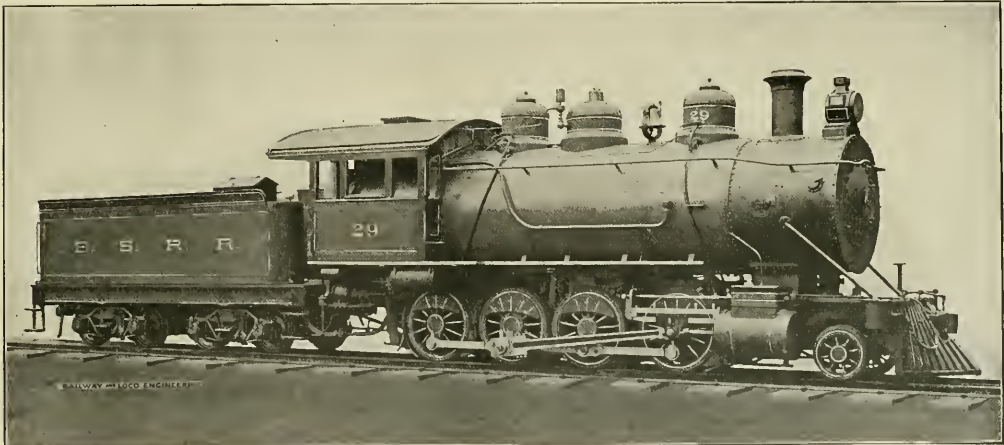

HEAVY FREIGHT 2-8-0 FOR THE BIRMINGHAM SOUTHERN

R. C. White, Master Mechanic

Baldwin Locomotive Works, Builders

municating between those compartments and the passenger compartments. Electricity, generated by a De Leval steam turbine dynamo, placed on the footplate, under the control of the driver, is used for lighting the car, each of the head lamps being of 50 candle power. The car can also be heated by steam.

A small fire occurred at the Brooklyn plant of the H. W. Johns-Manville Co., of New York, on the evening of August 30. In spite of some exaggerated accounts which appeared in the newspapers the damage was comparatively small, and the fire has not in any way interfered with the business of the company, as the department affected was in operation by about noon of the following day.

truck and the leading drivers are equalized together in the usual way, but the second pair of driving wheels is equalized with the front, so that the engine has the first three pairs of wheels all equalized together. The main drivers and the rear pair are equalized together with coil springs at the outer ends of the system, and semi-elliptic springs between the wheels, placed between the frame bars. The second or intermediate driver tires are without flanges.

The boiler is a straight top one, 78 ins. outside diameter. The dome is well forward on the second course, and has a ¼ in. strengthening liner on the inner side of the sheet, with an opening of 26 ins. The dome itself is 31½ ins. in diameter. The heating surface in the fire box of this engine is 195 sq. ft.; that

and 10 tons of coal. The total wheel base of engine and tender is just 50 ft. That of the engine is 22 ft. 4 ins., with a rigid wheel base of 14 ft. 3 ins. The total weight of engine and tender is about 275,000 lbs., the engine itself weighing 167,220 lbs. Some of the principal dimensions are as follows:

Boiler—Thickness of sheets, ¼ in.; fuel, soft coal; staying, radial.

Fire Box—Length, 112¼ ins.; width, 42 ins.; depth, front, 75 ins.; depth, back, 72 ins.; thickness of sheets, sides, ¾ in.; back, ¾ in.; crown, 7/16 in.; tube, ½ in.

Water Space—Front, 4 ins.; sides, 3 ins.; back, 3 ins.; measured at the mud ring.

Tubes—Material, iron; wire gauge, No. 11; diameter, 2¼ ins.

Driving—Journals, 8½x9 ins.

Engine Truck Wheels—Diameter, 30 ins.; journals, 5x10 ins.

Tender—Wheels, diameter, 33 ins.; journals, 5x9 ins.

### Engine Failures and Their Causes.

At the recent meeting of the Traveling Engineers' Association held in Chicago, Mr. F. P. Roesch, traveling engineer of the Southern Railway, contributed the following interesting paper on this important subject. He said:

Engine failures can be divided into three general heads, viz.; faulty construction, improper repairs, and improper handling. Under the first head would come: First, insufficient strength of various parts, due to incorrect design. This does not necessarily mean heavier parts, but a distribution of the material entering into the parts, so as to obtain the strength where it is needed. As for instance, in locomotive frames, in many instances, more material is added when all that is required is a different distribution. The writer is of the opinion that if frames were made I section, the metal could be distributed to much better advantage. In this connection, it might be well to call attention to a defect in design due to incorrect distribution of material in some locomotives recently turned out. It was but a small mistake but one which proved very costly to the railway operating the engine. This was simply a poor design binder or pedestal brace. The engines referred to had main frames designed as shown in sketch, which shows the main jaw of an eight wheel passenger engine. These engines were continually breaking the frames just over the main jaw. The trouble, however, was in the binder or pedestal brace, which was too weak at the point shown, and of course when this binder broke, the frame had to go.

However, faulty construction and design is responsible for but a small percentage of the engine failures.

#### IMPROPER REPAIRS.

To this factor, we can attribute fully 20 per cent. of our failures. These improper or half way repairs usually are made in the roundhouse and are due to the chronic shortage of power prevailing on most railroads at some time during the year. The call for power as fast as it can be furnished leads to many jobs being slighted, jobs that may not be absolutely necessary at the time, and which the foreman considers can go for another trip, figuring on catching them next trip when he is not so busy. But unfortunately this slack time never comes, consequently the job is put off from trip to trip until finally it results in failure.

These half way repairs refer not only to the machinists but to the boiler makers also. Many a time have you fullered up a crack in a side sheet when it should have been plugged, many a time have you expanded a leaky flue

with a taper pin when it should have been rolled or beaded. If you watch the matter closely, you can see these jobs every day.

#### IMPROPER HANDLING.

Here is the meat in the cocoanut. Although hard to prove, 50 per cent. of the road failures are due directly to improper handling of the engines. Beginning with the fire kindler, he kindles fire at the rear of the fire box and makes the beginning of a failure due to leaky flues. Next comes the hostler who starts to take the engine out of the house without opening the cylinder cocks. He makes the beginning of a future failure by straining cylinder heads, studs, etc., and washing the oil off the valve seats. Next he runs on the turn table at 6 or 8 miles per hour and as each wheel strikes the table, it falls from  $\frac{1}{2}$  to 2 ins., starting the future failure of springs or spring rigging. Next comes the hostler helper who in filling the tender with coal piles it up around the manhole and then washes it into the tank when taking water, starting a future injector fail-

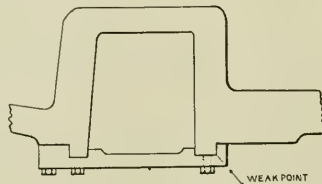

WEAK SPOT IN PEDESTAL BINDER

ure. He next takes sand, but whether wet or dry, screened or not, is a matter of supreme indifference to him. But we have failures due to no sand! Now comes the fireman who fills the lubricator from a tallow pot with no strainer in it, and then screws the filling plug tight with a long handled wrench. Lubricator stops up some night or plug blows out on account of threads stripped. Result, cut valves, broken yokes, etc. Now comes our engineer a little late, he's in a hurry. Drops a little oil here and there, misses the hole, finds it out after it is too late. Report. Flaw in iron. Couples on to train. Still in a hurry, hits train rather hard, sprains draft rigging, no immediate bad result, but saving up something to help cause a future failure. He starts, still in a hurry, slips her a little, tears up new light fire, also strains and loosens various parts. He finally gets to the end of his run. Along comes the brakeman, closes angle cock on air hose, lifts the pin lifter and gives engineer a go-a-head sign, air hose are pulled apart; probably no immediate damage done, but joints and fastenings are strained to develop later. Engine finally lands on

the cinder pit. On goes the blower, down goes the dump grate, open comes the fire door and fire is knocked. The hostler notices that engine has not enough water to fire up again, so on goes the injector, fire or no fire so long as he has steam enough to bring her in.

Engine is now run into the roundhouse and placed under the smoke jack. Dampers wide open or cold air being drawn through perforated sides of ash pans and through the flues, causing such a series of contractions that it is strange that no more damage results than what we notice. We won't say anything about what takes place if the boiler is to be washed, as that is a subject to which all are becoming alive, but nevertheless, there are many roundhouses where a change in the method of caring for boilers would help materially to reduce the engine failures. We as Master Boiler Makers, are more interested in the troubles due to boiler failures, we need not dwell on the other causes but start to cast the beam out of our own eyes before we tackle the mote in our brother's.

In a very able paper on the Care of Boilers, by Mr. M. E. Wells, read before the Western Railway Club in November, 1905, particular stress was laid on the variations of temperature in the boiler and its effect on the flues and side sheets, caused by putting in feed water through the injector when the engine is standing still and the water is not in circulation (apparently), dwelling particularly on the evils of using the injector on the cinder pit or while standing on side tracks, or in cooling off a boiler preparatory to washing out by forcing cold water through the feed pipe.

Mr. Wells' argument was that more damage is done and more leakage produced in this manner than is or can be caused by any inflow of cold air through an open fire door. While Mr. Wells puts up a very strong and plausible argument, yet, my experience on the road while running an engine caused me to rather doubt the correctness of his conclusions. Understand, I am not saying that the temperature of the water in a locomotive boiler is, or remains the same in all parts of it, as we all know better. Natural philosophy teaches us that the hotter water naturally rises, but I was inclined to doubt whether the expansion and contraction of a boiler and tubes was in the same ratio as the variation in the temperature of the water. I therefore made a few experiments for my personal satisfaction and arrived at somewhat different results.

You see I argued that if all the leakage was due to this difference in temperature, why did not the old style of

boiler with deep narrow fire box and impeded circulation due to the narrower water space give us the same trouble as the present type of wide shallow fire box and greater water space designed especially with a view to better circulation. According to the temperature theory, it could not possibly be due to increased steam pressure, as the variations of temperature are practically the same regardless of pressure.

TEST NO. 2. ENGINE 604. WIDE FIRE BOX.

In this case three lengths of tubes were taken, namely, top, middle and bottom, to see if there were any variations due to location.

Read- ing.	Pres- sure.	Temp.	Boiler.	Top Flues.	Mid. Flues.	Bot. Flues.
1....	74 lbs.	320	00	00	00	00
2....	00	180	6/64	8/64	7/64	6/64
3....	00	40	14/64	16/64	15/64	12/64

After first reading all steam was blown off the boiler through relief valves, but the water was left in the

than the boiler or middle and bottom flues.

The boiler was now allowed to stand three hours after which it was filled with warm water at 98 degrees and the third reading was taken after filling. You will notice in all cases, the flues at first contracted more than the boiler while in the final contraction, the boiler contracted more than the flues; proving to my mind at least, that the initial contraction is due to the inrush of cold air alone, while the difference in the final contraction is due to the difference in the thickness of the iron in the tubes and the boiler shell. Under such conditions is it any wonder that we have leaky flues?

Now to suggest a remedy. The only one that appears to me at present is to stop this inrush of cold air after the fire had been knocked and that can only be accomplished on our present engines by covering the stack after the engine comes into the house.

As the principal damage occurs, however, while the engine is being moved from the cinder pit to the house, the only other remedy open would be not to knock the fire except when absolutely necessary to wash the boiler, hence the fewer times the boiler is washed the less will be the leakage, and the longer the life of the flues. We must, therefore, find a way of keeping the mud out of our boilers without washing so frequently. As

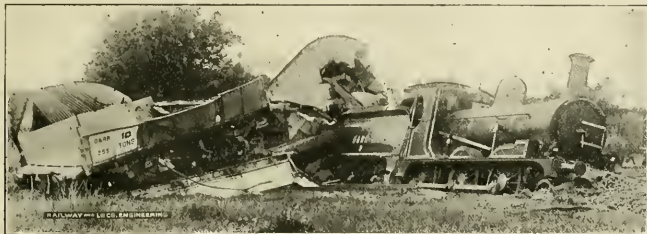

WRECKED UNDER INDIAN SKIES

In order therefore to learn exactly what takes place when a boiler is cooling, I made three micrometer trams of wood, well dried, with which to gauge the length of the tubes and used a fish tail tram of equal length to gauge the contraction of the boiler. We took the length of the flues immediately after the fire was knocked and at the same time took an equal length on the outside of the boiler, then after boiler had cooled down a stated period, we again took measurements and made our comparisons. To say that the results were surprising is putting it rather mildly, as it seems strange that there should be any variations between the contractions of the tubes and the boiler while the water within was of a practically equal temperature—that is, the tubes at least were surrounded with water having the same temperature as that which come in contact with the shell.

The following are the results of a few readings taken, the tests are not completed at this writing, however.

TEST NO. 1. ENGINE 770. WIDE FIRE BOX.

1st Reading 9:15 A. M.

Temp.	Boiler Cont.	Flue Cont.
358°	00	00

2d Reading, 12:45 P. M.

305.5°	4/64	6/64
--------	------	------

3d Reading 3:10 P. M.

233°	14/64	10/64
------	-------	-------

In this case, boiler was filled before fire was knocked and engine allowed to cool gradually. No water put in while cooling. It will be noticed, however, that in the initial cooling the tubes contracted 2/64 ins. more than the boiler, while in the final cooling the boiler contracted 4/64 ins. more than the tubes.

boiler. This, you will notice, flatly contradicts Mr. Weis' arguments, as the top flues where the water was hottest contracted the most.

After the second reading the boiler was cooled off gradually by forcing cold water through the injector and allowing the hot water to run off through the blow off cock until the boiler was cold.



"SOMEONE HAD BLUNDERED"

TEST NO. 3. ENGINE 607. WIDE FIRE BOX.

In this three different tubes were taken as before.

Read- ing.	Pres- sure.	Temp.	Boiler.	Top Flues.	Mid. Flues.	Bot. Flues.
1....	160 lbs.	363	00	00	00	00
2....	00	172	10/64	9/64	11/64	11/64
3....	00	98	20/64	18/64	20/64	19/64

After first reading, the water was all let out of the boiler but no cold water put in. Here again we find a contradiction; the top flues contracting less

this leads us to another subject, however, we will close this paper and let the means of keeping our boilers clean without frequent washing come out in the discussion.

The office of the Pressed Steel Car Company of Pittsburgh, in Mexico City, is now Prolongacion del 5 de Mayo No. 9 instead of Calle de Gante No. 8. Mr. D. G. Farragut is in charge.

**Chuck for Flat Drills.**

At the Brightwood shops of the Big Four, there is in use a chuck for flat drills that is worth looking at, and it is through the courtesy of Mr. F. M. Lawler, the master mechanic in charge, that we are able to present an outline of it to our readers.

The flat drills for this chuck are notched, at intervals, along one edge, and the spindle for holding the drill is cut so that the long notched end of flat drill passes up into it. Over the top of the spindle a case is slipped which screws down to a collar and is held in

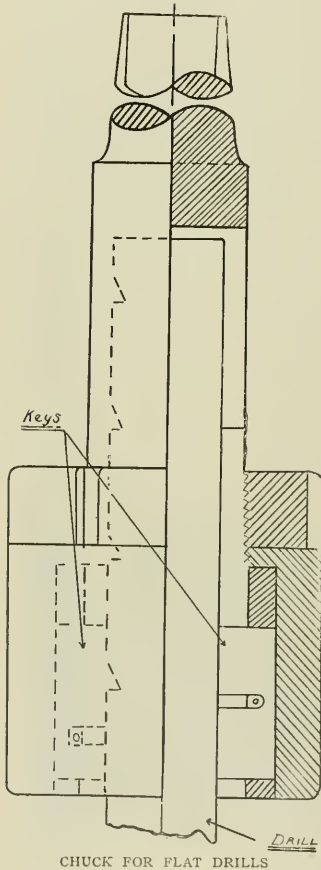

CHUCK FOR FLAT DRILLS

position by a nut run down above it. The case is recessed out inside so that although it will just contain the drill holder, having a diameter of  $2\frac{3}{8}$  ins., yet has a pair of crescent shaped cavities on two sides. The tool holder is slotted so as to receive two keys, one of them having a projection which fits the notches in the flat drill. These keys are able to slide in and out of the slots in the tool holder. The keys are kept in place by two pins which prevent

their falling into the space occupied by the drill after it has been taken out. They cannot get out at the back when the case is in place, so they stay where they are, being able to close in on the edges of the drill or move back and free it.

The method of forcing them to close in on the drill, is to revolve the machine spindle through part of a turn while holding the drill fast. The keys stand away from the drill when their backs are out in the crescent shaped spaces of the case, but when the case revolves the sweep of the narrowing moon shaped spaces forces the keys hard in on the edges of the drill. The projection on the key and the notch in the drill coincide and the drill is held fast, and without the possibility of a shake while the flat slot in the spindle does the driving. The act of

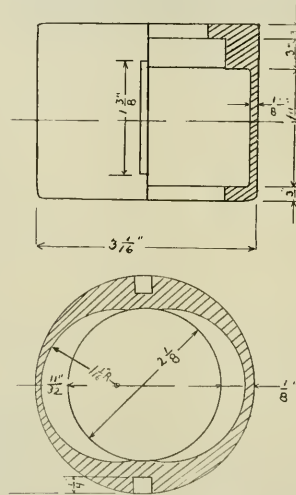

CASE WITH CRESCENT SHAPED CAVITIES FOR KEYS

turning in the work holds the drill tight, and turning in the opposite direction with drill held fast, loosens it.

There are two sets of keys; one set for 1 to  $1\frac{1}{2}$  in. drills and another set for  $\frac{1}{2}$  up to 1 in. drills. The keys are made  $\frac{3}{8}$  in. in width,  $1\frac{1}{2}$  ins. long, rounded top and bottom and slightly rounded on the back. The case has a mark or letter stamped upon it so that the side containing the key with the projection is easily identified and the drill can always be inserted so that these will engage. In order to remove a drill, the spindle with the case is turned back and the drill held fast and the keys then no longer exert pressure on the edges of the drill, and the drill becomes loose in the act of taking it out. The chuck is simple and efficient and its parts are easily renewed whenever that becomes necessary.

**Survival of the Fittest.**

People who are in touch with the investigations into the value of alcohol as a power medium perceive signs of coming disappointment, but this will

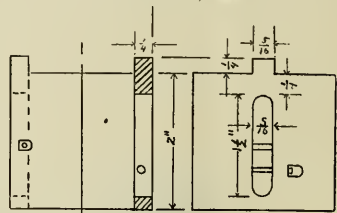

CASE SHOWING CROSS PINS FOR KEYS

not be by any means the first case of proposed power mediums failing to meet expectations. Steam made from boiling water was long the most popular means of converting heat into work, but a great many substitutes have been tried besides the successful gas engine. Numerous compounds including ammonia, carbolic acid gas have been tried but found wanting. When liquid air was first produced many people believed that it could be used as a power producing medium, but no one cares to advocate such a thing nowadays. The old fashioned steam engine and the newer product, the gas engine, are left in possession of the power field.—Automobile Magazine.

It is only eight years since a deputation from the Belgian State Railways visited Britain in search of the best type of locomotive for working their fast international expresses, and already throughout Belgium there are at work

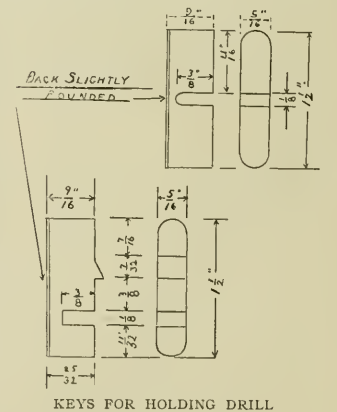

KEYS FOR HOLDING DRILL

several hundreds of engines that could scarcely be detected from those of the Caledonian Railway. They were designed by Mr. McIntosh, the mechanical engineer of the latter company, at the request of the Belgian government.—N. Y. Globe.

# General Correspondence.

## Hates Air Sanders.

Editor:

There are some attachments that have been put on locomotives that have proved to have been fads, but once established they are seemingly hard to get rid of. One of the fads that is a real nuisance is, to me, the air sander, and of these there are two kinds, one inside the sand box, the other outside. Of the two, I would prefer the outside one, if dry weather was absolutely certain at all times. If it is moist or rainy, the outside sanders are then absolutely impervious to letting sand through. There are too many couplings and joints for moisture to work through and destroy their usefulness. The outside sander is easier to get at, to regulate and repair, but it is a perfect nuisance in damp or rainy weather.

The sanders located inside the box when they are out of order, the sand box has to be employed before they can be put in working order and that is out of the question out on the road. There are quite a number of air sanders on the market that will do fairly good work for a short while when new, but the nozzles soon get worn too large. The air blast is then too strong, and if it takes the sand along, blows it with such a rush it will sand the right of way, by blowing it clear off the rails. If the air nozzle is too large with the inside sander the air blast is so strong against the crook in pipe that it blows the sand back again and cause a rush of air at the rails, but no sand. With a dry rail, not much sand is needed. In wet weather, the air sander is almost sure to fail.

I ran an engine a few months ago equipped with a gravity or hand sander, and also with an air sander, and an inside one at that. In the six months I ran the engine I paid no attention whatever to the air sander, for the gravity sander I could depend on in wet weather or dry. Whenever I wanted sand on the rail it was forthcoming. This engine went to the shop and I was furnished with another engine with air or economy sander; you bet it would save sand, but to get sand on the rail was out of the question. I reported it not working each trip; the pipes would be taken down each time, sand stirred up with a wire and all fixed up again. When engine was taken out of the house sander would work for perhaps one second and then quit again for the trip. I asked the M. M. if he would not put on the old gravity sander again, but he

did not see his way clear to comply with my request, but said he would put the air sander in shape to do business. He did, but it was only for a few days, and it got back again very soon to its old way—no sand.

If the master mechanics insist on equipping each engine with an air sander the hand sander should be left on also instead of taken off. Take a freight train on a few miles of ascending grade with a slippery rail, an air pump working to its capacity to supply leaks on train

the pipe leading to the rail and a five minute rain will put it out of commission effectually. All the air sanders ever invented can never compete, day in and day out, with the good old Armstrong sander with one continuous piece of pipe, 1¼ ins. diameter from sand box to rail. It will save shop help and repairs, save tire wear, save annoyance to the engineer, and save money for the company. Of course, it will require more sand, but economy in the use of sand is too cheap to talk about.



"LOOKING PLEASANT." JUST BEFORE THE START

line, then put on an air sander; result, brakes apply, then you double the hill, which, of course, is very gratifying, not alone to the engineer, but to all concerned.

Reports of this character don't seem to have much effect on the mechanical department. Some of the engines here are equipped with one of the first patented back action double action and every other action, but when it comes to getting sand to the rail properly, there are sixteen joints between sand box and

From my experience with all kinds of air sanders, too numerous to mention, they are the most abominable nuisance ever put on a locomotive.

JOHN MILLS.

Huron, S. D.

## Does It Every Day, All Right.

Editor:

I notice in the September issue of RAILWAY AND LOCOMOTIVE ENGINEERING, on page 410, under heading of "Fastest Trains of Two Continents," you say the

fastest train on the American continent is on the Atlantic City Railroad, which covers 56 $\frac{1}{2}$  miles in one hour. Will you kindly note the schedule of trains Nos. 25 and 26 on the Michigan division of the Lake Shore & Michigan Southern? You will note that this time is considerably faster than the time referred to by you.

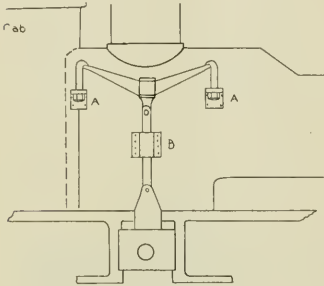

FIG. 1. OLD TIMER'S SKETCH OF SPRING GEAR

The train referred to in time card is the Twentieth Century Limited. This train has no scheduled stops between Elkhart and Toledo, the distance being 133.4 miles, and scheduled time is 2 hours and 15 minutes, or 133.4 miles in 135 minutes. This, I believe you will find, will give an average speed of 59.28 miles per hour. This train covers this distance regularly every day in the year. On several occasions the train has traveled over this distance in much less time, on one occasion 114 minutes, and several times, to my knowledge, it has covered this distance in 121 minutes. The time given on the time table opposite stations does not mean that train stops there; this merely shows the time which the train is due at the station. A stop is indicated by letter "s."

For the information of your readers, I will further say that this train consists of six cars, on this division, namely: combination buffet and baggage, dining car, observation car, and three sleepers. These cars all being Pullmans, average weight being about 120,000 lbs. C. H. WEAVER.

Collingswood, O.

#### Early Norris Engines.

Editor:

I have been chasing that high hung spring peculiar to some early Norris engines and inclose two sketches or copies of same sent me by old-timers. Fig. 1 shows the high location of spring, but it calls for rear driving axle passing through ashpan, the brackets *AA* and guide or saddle *B* being bolted to side of boiler. The sender informs me they were six-wheel connected engines. Norris did build some six-wheel connected engines and I am quite sure they had

trailers under rear end. Fig. 2 is copy of sketch sent me as accurate. Now, you can see the impossibility of this arrangement as it shows more spring than anything else. Fig. 3 is my own solution of the question, as the engines on which I saw the high hung spring were eight-wheelers. You will notice the position of engine truck, another peculiarity of early Norris engines. Of course, it made an extended wheel base, but the forward drivers had a wide blind tire which made them curve easy. I also spoke of back ends of valve rods being higher than forward end from a horizontal line. Does not the old, so called Crampton, engine in your issue of July, 1905, show this peculiar position of valve rods? The engines I quoted in a former article, I am quite sure, had back end of steam chest elevated. Now, was not this so-called "Crampton" engine designed by Mr. Isaac Dripps, M.M., of the Camden & Amboy, and built by Norris, of Philadelphia, or am I mistaken? If I am, call me down.

When the repair shop at Parkesburg on the old Philadelphia & Columbia R. R. was first built the turntables were put in for the motive power as it then existed. The shop had nine

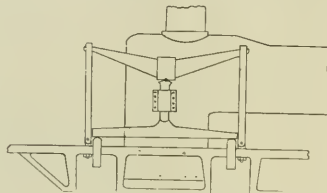

FIG. 2. ANOTHER OLD TIMER'S SKETCH OF NORRIS ENGINE SPRING GEAR

pits; each pit had its own door in front and in front of each pit was a small turntable, or nine turntables in all. These tables were large enough to take the engine without the tender, and as the engines were all of the single driver type, or 4-1-0, they did not call for a very large turntable, but in a very few years the engines outgrew these little tables, and until such times when a larger table could be put in, a pair of portable extensions were used, as shown in the sketch, Fig. 4. These extensions were not fastened together but handled separately.

The extensions were forged with the lugs *BB* to fit down on either side of the rail, the forward end having a turn-up *A*, the forward drivers resting on the back end of the extension kept it from raising when engine truck ran out toward the end, and it worked very well, as the table revolved on a series of wheels running on a rail near its outer edge. We must remember that the engines using these extensions were hook motion engines, and fitted with the old time hard-to-move slide throttle, it re-

quired a great deal of skill on the part of the man with the eagle eye to place the engine on the table. While speaking of this row of nine little turntables the writer's thoughts go back to his boyhood days and how he wished to take a locomotive, start at upper end of side track and take a run over the turntables to see what the effect would be.

W. DE SANNO.

Alameda, Cal.

#### First Air Brake Train.

Editor:

In connection with the subject of the recent death of Daniel P. Tate, at his home in Steubenville, O., an old-timer and one of the best known engineers

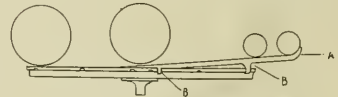

FIG. 4. SHORT TURN TABLE WITH EXTENSION FOR TRUCK

on the Panhandle Railroad, and, for many years following, general foreman of the shops of that road at Steubenville, revives interest, as to him belongs the honor of being the engineer on the first train ever controlled by air brakes. It was a local passenger train on the Pittsburgh division of the Panhandle, and the event took place in April, 1868.

Some time previous to this date, arrangements were made with Mr. W. W. Card, then superintendent of the road, by Mr. George Westinghouse, to try his brake, which was of the "straight air form," and but a short time previously patented by Mr. Westinghouse. The train was the Steubenville accommodation, operating between that city and Pittsburgh, the round trip being a distance of 86 miles. Some of the early experiences with the air brake are best told by Mr. Tate himself in a statement made to Pittsburgh railroad officials regarding the first test of the air brake, and which is something as follows:

"Yes, I ran the first air brake and,

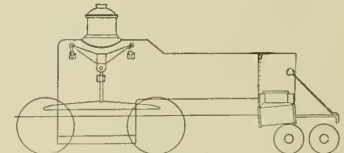

FIG. 3. DE SANNO'S IDEA OF HOW IT WAS

moreover, along with Nick Johnson and Harry Frazer, helped George Westinghouse put the first air pump on an engine. We put it on the '23,' a little eight-wheel Dickie Norris engine. The pump was one made over from an old Cameron water pump and lay flat on its back on the running board outside of my front cab window. I'll never forget



it had a leather packing in the air cylinder.

"This pump was subsequently replaced by one that stood upright on the side of the boiler (6 in. pump), and we used to take turns pushin' and pullin' at the trigger valve motion to keep it going when it wanted to 'lay down.' While the brakemen liked the new brake, the president of the road objected, for it always seemed to be getting out of order. Hanged if it didn't seem to go wrong every time he was on the train, but there was never a trip but what it worked part of the time. When it got out of order and we had to go back to the hand brakes, we worked all night, but we got it in shape for the next day's trip. However, I was only too glad to work on it nights, for I saw it was a 'comer' and told Mr. Westinghouse so. From the first stop I ever made with it, the stop at Fourth avenue, Pittsburgh—the stop where the Westinghouse air brake drew its first breath of life—I saw it was a wonderful thing. Mr. Westinghouse was in the cab with me on that run.

"It seems queer, too, that the first emergency stop was also made at this same Fourth street station upon starting out on the second trip. A coal train carrying no red flags for markers tried to pass over ahead of me. I did not see the train until it came out from behind a high fence not more than forty feet away. I banged on the air and things looked bad for all hands. The waiting passengers on the station platform scattered and ran in a panic. When the train stopped the '23's' pilot stood off just four feet from the coal train. That was a fine exhibition stop."

Following several months of experimenting on the Steubenville accommodation, officials of the Pennsylvania Central Railroad, now the Pennsylvania Lines East of Pittsburgh, in September, 1868, caused the new brake to be applied to the "Walls accommodation," a train operating between Pittsburgh and Walls, some sixteen miles, Levi W. Close being the engineer. Somewhat later the brake was placed in service on all through passenger trains, the Pennsylvania being the first to adopt the air brake as its standard.

From this time the value of power brakes rapidly gained recognition and but a few years elapsed until hand brakes had been relegated to seclusion so far as handling passenger trains was concerned. It is a fact worthy of note that nearly all the men who assisted Mr. Westinghouse during the trying times when the air brake was undergoing its earlier development became identified with him, and of those above mentioned, all of whom have passed away during the past four years and were in the service of the air brake company more than a quar-

ter of a century, Mr. W. W. Card filled the responsible position of secretary; Nick Johnson was shop foreman; Harry Frazer, inspector on the Pacific coast, and Levi Close occupied a similar position with headquarters at Pittsburgh.

The engineer of the present time little realizes the grief which befel his older brother during the early days of the air brake, the 6 in. pump with its "trigger" valve gear, being the most uncertain quantity of the brake system. Its erratic actions were of a character to defy anticipation.

The pump seldom gave any preliminary symptoms of trouble, though it was liable to "lay down" at any time when it was apparently ready and willing to properly perform the duties expected of it.

The engineer upon attempting to start the pump frequently found it necessary

following a movement of the three-way cock handle, to release which was done by opening a steam globe valve, causing a slight vacuum in the train pipe and brake cylinders sufficient to move the pistons to release position, thus disengaging the brake shoes from the wheels.

S. J. KIDDER.

### Oscillating Cylinder Locomotive.

Editor:

I am sending you a photograph of a decidedly novel locomotive. While the mechanical world is disputing over the merits of the Walschaerts valve gear, or the Stephenson link, here is an engine without either. It has no links, eccentrics, steam chest or valve, and no reverse lever.

As will be seen by the picture, it has oscillating cylinders and the piston rods are coupled direct to the crank pin. The



ENGINE WITH OSCILLATING CYLINDER AND NO VALVE GEAR

to operate the valve gear by hand, until the pump "limbered up," by the use of a rod, one end of which was attached to the trigger valve gear, the other ending in a handle inside the cab. The writer recalls more than once when he was obliged to manipulate the gear by the mechanism just mentioned, during the entire trip of 115 miles with a train of six or seven cars, making all station stops.

Indeed, so uncertain was the air supply that among the time card rules was one to the effect that "brakemen must be at their posts, the hand brake, at all times when approaching stations or descending grades."

It required the engineer to be a pump governor, and, as can be readily imagined, between getting too much air pressure or not enough he was compelled to be constantly on the alert. It even devolved on him to "push the brakes off,"

engine is reversed by means of a 4-way cock, which changes the steam pipe into an exhaust pipe and vice versa. The cylinders oscillate on a trunion, which passes through the saddle casting. This trunion passes through a coiled spring which pulls the cylinder up against the saddle, allowing it to turn and yet make a steam tight joint.

I think everyone of us owned, when we were boys, a little "dollar steam engine" with an oscillating cylinder; but I never expected to see it applied to a locomotive.

There is no way to shorten the cut-off, so she must work "down in the corner" both ways. There are about 25 of these engines in service, mostly on logging roads. They are built by Dewey Bros., Goldsboro, N. C., who make them 7x14, 8x14 and 9x16 in. cylinders.

E. W. GREGORY.

Hoffmanville, Md.

### Glimpse of Japanese Railways.

Editor:

The service which possessed lines extending altogether 5,599 miles, on March 31, 1905, had its inception in 1872, when there was only one short line of eighteen miles, that being the Tokyo-Yokohama line.

The most patronized line between Tokyo and Kobe, Osaka and Kyoto, is a trunk line well known by the name of the Tokaido line, the great highway of eastern Japan, which skirts the coast along the narrow strip of flat country intervening between the foot of the hills and the Pacific ocean.

On its way rises the majestic Fujiyama, pride of Japan, 12,365 ft. in height, an altitude easy to remember, if we take for memoria technica the twelve months and the three hundred and sixty-five days of the year.

One of the most difficult lines constructed was that opened for traffic in 1893, on the way from Tokyo to Naetsu, where now exists a large establishment of the Standard Oil Company. It leads over a steep mountain pass, the inclination of which is 1 in 15 (352 ft. in a mile) for a length of five miles, three miles of which are tunnels, all cut through solid rock. The train is taken up the pass by "Abt" engines, which have a cogwheel working on a rack rail laid between the ordinary rails, and I may say to the readers of RAILWAY AND LOCOMOTIVE ENGINEERING that the Japanese railways are narrow gauge, 3 ft. 6 ins.

This engineering feat would be nothing when compared with the works encountered in building railroads up to cloudland in Colorado—an altitude of 14,007 ft., not to say of Pike's Peak railway, or of electric train and elevator to the top of the Zungfrau, the icy altitude of 13,720 ft. in Switzerland.

But to return. Japanese railway enterprise was started by the government and there were numerous small railway companies, forty-one all told. This may give some idea what sort of companies they were, when, taken on the whole, the total mileage was not more than 5,600 miles in the whole empire.

Last spring the government decided to purchase all the private railway companies' lines with all their appurtenances, and the bill passed through the Diet. Outsiders, no doubt, wish to see how it would result.

With respect to the total number of vehicles and their hauling capacity and their weight, the following figures may be of interest:

The total number of engines, carriages and wagons amounted to, respectively, 1,644, 5,242 and 24,408. The average weight of the engine being 44.9 tons (2,240 lbs.). These 5,242 cars possessed seating accommodations for 201,

558 persons, an average of 33.6 seats per car, while 24,408 goods wagons possessed a freight capacity of 164,506 tons, being an average of 6.7 tons per wagon. The ratio of vehicles to mileage under traffic was, according to the same statistics, 35 locomotives, 128 passenger cars and 520 wagons per 100 miles.

M. C.

Philadelphia.

### Pneumatic Bell Ringer.

Editor:

The device, a sketch of which I send you, has been in successful operation on

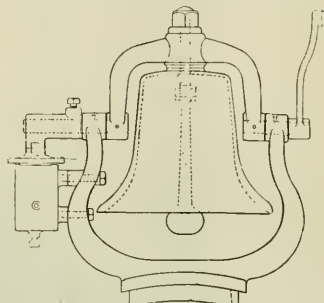

PNEUMATIC BELL RINGER

the Denver & Rio Grande for more than two years. It is not a patented device, so that if any of your readers desire to make use of it they will find that it is all right.

When pressure is admitted in inlet port 7, Fig. 1, the piston 2 will move upward and the crank 12, with roller 11, fastened to the bell yoke shaft, is moved from left to right. The piston will move up until stopped by the outside diameter of the crank sleeve. During the upward movement of the piston the pin 10 reaches the end of the slot 3, carrying the valve 4 with it, thus closing the inlet port 7, and opening exhaust port 9. This allows pressure under piston to pass through ports 8-8 and out of port 9 to the atmosphere. The weight of the bell will then move the crank with roller from right to left, which when it reaches the sloping disc or mushroom head of piston 2, moves the piston down, and while passing over the center leaves the valve 3 in register with inlet port 7 by pin 10 coming in contact with the bottom of the slot and closing the exhaust port 9, ready to move the piston up for the next swing of the bell, same as before when the bell is free to swing down and repeat the operation.

There is thus positive valve travel regulated by pin 10, in combination with the split eccentric sleeve 13, which by being turned on the bell yoke shaft, shortens or lengthens the travel of the piston and thereby either partly closing or

opening the admission port to suit bells of different weights. The setscrew with jam nut, is used to make the valve movement permanent, by not allowing the momentum of the piston, moved by the weight of bell, to push valve past the required opening.

The application, or installment, of the device on bell frame is simple and compact.

HENRY BREITENSTEIN.

Denver, Col.

### Baldwin Mallet Compound.

Editor:

The Mallet compound shown in the October number of your paper is very interesting. I wish my old employer, the late Mr. Wm. Mason, were alive and could see his bogie truck, flexible steam pipe and Walschaerts valve motion in use once more. It only proves that to accomplish an object and overcome an obstacle, something must be done.

If more common sense thought to economy were given, our railroads could be run to better profit.

I am reminded of a road which came into possession of another road by a lease. In order to save money all the domes, sand boxes and smoke stacks were changed, so the engines on the road would look alike. It is supposed that the engines steamed better, ran faster and consumed less coal per mile.

HERBERT FISHER.

Taunton, Mass.

### Railway Accidents.

The following letter from Angus Sinclair appeared in the New York Sun of October 4, and was written after reading the account of the recent rear-end

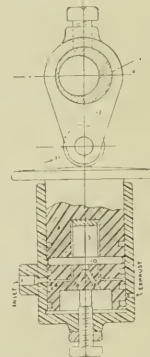

CYLINDER OF BELL RINGER

collision on the Pennsylvania Railroad:

To the Editor of the Sun—Sir: The human equation is an element that cannot be ignored in considering causes of railroad accidents, but there is a possibility of reducing the error-producing

human equation to its lowest terms; a process which appears to be habitually neglected on the Pennsylvania Railroad. The system is provided with the very best mechanical appliances for keeping trains from touching each other, yet the daily practices vitiate all the precautions made to insure safety.

You say that a high official of the railroad made the singular admission that "trains do run past the cautionary or green signals very frequently each day, at a speed of sixty miles an hour, but we do not consider that to be nec-

punishment. Perhaps behind him is a "high official" whose policy it was to encourage the violation of rules. In that case he is the real criminal and ought to be held personally responsible.

American travelers who have had experience with British train service and understand the crowded condition of the railways on that side, marvel that the immense traffic is conducted with so few accidents. The reason is that block signal protection is universal, and train rules are enforced strictly. When an accident does happen there the cause is investi-

### Ballast and Sleeper Wagons.

BY A. R. BELL.

The four wheeled wagon which forms the subject of one of our illustrations, Fig. 1, is used for ballast, and is intended to carry a load of 20 tons, the inside measurements being 20 ft. in length, 8 ft. in width, and 2 ft. deep, this latter dimension being, of course, exclusive of the hopper in the center. In addition to the body side doors, four independent doors for the hopper are provided, and these have a special fastening arrangement. The wheel centers are of cast steel, the tires being secured to the same by set screws. The journals are 8x6 ins., and the axle boxes have been designed for oil lubrication, not grease. The screw brake can be operated from either side of the wagon, brake blocks or shoes being supplied to each of the four wheels.

The sleeper and rail bogie wagon has a total length over the buffers of 51 ft., and is used for the conveyance of steel rails, sleepers, or ties, as they are called in America, and other similar material. On one side of this wagon the removable side stanchions are shown in our illustration, Fig. 2, as they are when in position for unloading the rails, and this constitutes a special feature of these wagons. Ten mild steel bolsters are riveted to the wagons, and these were, in the making, specially pressed to shape by hydraulic plant. The wagons are provided with the usual binding chains with screw couplings, etc., while the wheels, axle boxes and brake arrangements are precisely similar to those of the four wheeled wagons. Both types of wagons are constructed

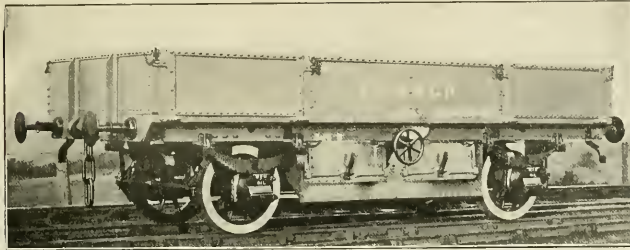

BALLAST WAGON, LONDON, BRIGHTON AND SOUTH COAST RAILWAY

essarily unsafe." That is a remarkably frank admission, but it is by no means singular, for similar practices prevail on nearly all railroads, and they are the direct cause of nearly all accidents that happen on block signal protected railroads.

An expensive system of block signal equipment, which will absolutely prevent trains from coming together if the rules are obeyed, is introduced on a railroad. To prevent loopholes through which accidents pass, the officials of the railroad are supposed to see that the rules controlling the perfected system of protection are obeyed strictly, and that every engineer taking on himself the responsibility of running past a danger signal is disciplined for the offense. In practice, unfortunately, this strict obedience to important rules is not enforced. "Get your train through on time," is an imperative injunction hanging over all express train engineers. "Make up lost time if possible" is another piece of advice always in evidence, and it is much better for a man running an express engine to pass danger signals without slowing down than it is to lose a minute of time. It is a melancholy fact that the reckless engineer who habitually takes his train in on time, violating rules at nearly every station, is the popular man with the officials.

When the inevitable accident due to violation of rules happens, the engineer is punished and has to carry all the blame. That is wrong. The superintendent whose duty it was to enforce the rules and who neglected to do so is the real culprit and ought to receive the

gated exhaustively by an official of the Board of Trade, who is well trained in the business. If rules were habitually violated with the knowledge of the officials the report would put the blame upon them. If a similar system were carried out in this country, say, by officers belonging to the Interstate Commerce Commission, and reports promptly published while the public conscience was afflicted by sanguinary accidents, the blame would fall

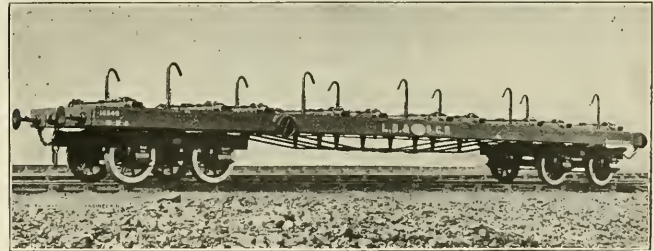

SLEEPER AND RAIL BOGIE, L. B. & S. C.

upon those really responsible. With that burden of odium imposed upon people who habitually neglected their duties of supervision, the much needed sentiment that rules are made to be obeyed, not to be habitually broken, would soon become popular. ANGUS SINCLAIR.

New York, October 2.

Let us have faith that right makes might, and in that faith let us, to the end, dare to do our duty as we understand it.

entirely of steel, and were built from the designs of the late Mr. R. J. Bilton, locomotive and carriage superintendent of the London, Brighton & South Coast Railway, of England.

By an order of the Prussian minister for railways, the female clerks are to be superseded by men. The women who have been withdrawn from the booking offices will be transferred to the telegraph and telephone services.—N. Y. Commercial.

### Three Cylinder Compound.

The Great Central Railway of England have had a couple of three-cylinder compounds built at their works at Gorton, the first of which is now in use. These engines, the drawings of which are shown, have been designed by Mr. J. G. Robinson, chief mechanical engineer of the company. The system of compounding is rather unusual, and may be outlined as follows:

When the throttle is opened for high-pressure work, steam is admitted simultaneously to all three cylinders, but that to the low pressure pair through a re-

duction of Mr. W. M. Smith. The method had already been tried on North-Eastern and Midland railway engines before being adopted by the Great Central. The leading dimensions, etc., for which, as well as the drawings, we are indebted to Mr. J. G. Robinson, are as follows:

**Cylinders**—One H. P., 19 ins. diam.; 2 L. P., 21 ins. diam.; stroke, 26 ins.; H. P. cylinder fitted with Smith's patent piston valve; L. P. cylinder fitted with ordinary slide valves.  
**Reversing Gear**—Screw; reversing both H. P. and L. P. together.  
**Wheels**—Cast steel; diam., bogie, 3 ft. 6 ins.; coupled driving, 6 ft. 9 ins.; trailing, 4 ft. 3 ins.  
**Axles**—Bogie, bearings, 6x9 ins.; H. P. crank axle, bearings, 8x9 ins.; crank pin, 8½x6 ins.; H. P. straight axle, bearings, 8x9 ins.; diam.

perial gallons; weight in working order, 44 tons, 3 cwt.; tender fitted with water scoop. Total Wheel Base of Engine and Tender—51 ft. 9½ ins.; total length of engine and tender over buffers, 61 ft. 10½ ins. Capacity of coal bunker, 5 long tons.

### Regular vs. Pooled Engines.

The committee which dealt with this subject at the recent Traveling Engineers' Convention had as its chairman, Mr. C. F. Richardson. The report, while stating that probably the unanimous choice of the men would be for regularly assigned engines, nevertheless, admitted that there were advantages

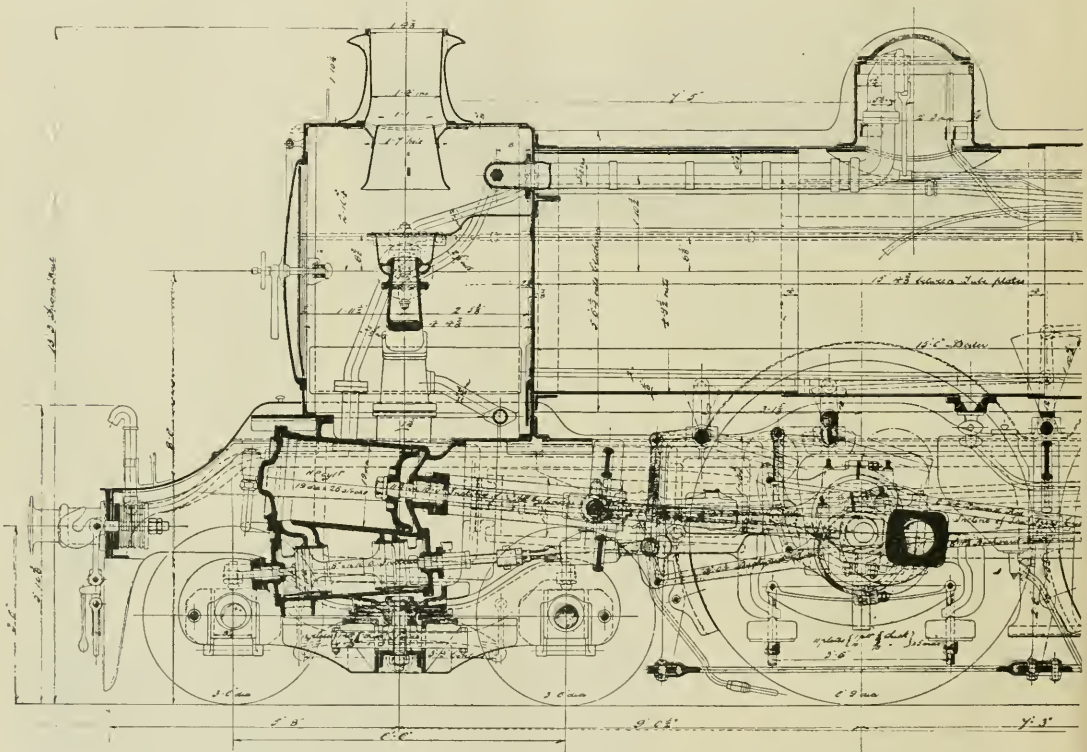

John G. Robinson, Chief Mechanical Engineer

THREE CYLINDER COMPOUND ENGINE

ducing valve. When well started, the valve is cut out and the steam passes from the high to the low-pressure cylinders as usual.

The peculiar feature about the compounding is that the pressure in the low-pressure cylinders may be augmented by means of the controlling valve at the expense of pressure in the high-pressure cylinder, so that the total effective pressure can be divided between the high and low-pressure cylinders in any proportion within certain limits.

This method of compounding, and the special segmental piston valve by which it is operated, are the design and inven-

at middle, 7¾ ins.; trailing straight axle, bearings, 6½ ins. outside by 11 ins.; trailing straight axle, bearings, 7 ins. inside by 5½ ins. long.  
**Boiler**—Telescopic, 5½ in. plates; front ring, 4 ft. 9½ ins. diam. outside; length of barrel, 15 ft.

**Fire Box**—Length outside, 8 ft. 6 ins.; width at bottom, 4 ft. ½ in.; length inside at bottom, 7 ft. 9 11/32 ins.; width, 3 ft. 4¼ ins.; stays, copper; pitch, about 3½ ins.; diam., 1 in.; two top rows, 1 1/16 ins.

**Tubes**—No. 221, B. W. G.; length between tube plates, 15 ft. 4¼ ins.; diam. outside, 2 ins.  
**Heating Surface**—Fire box, 153 sq. ft.; tubes, 1,778 sq. ft.; total, 1,931 sq. ft.; grate area, 26 sq. ft.

**Working Pressure**—200 lbs. per sq. in.  
**Weight of Engine in Working Order**—Bogie, 17 tons; coupled wheels, 37 tons; trailing, 17 tons; total, 71 tons.

**Total Wheel Base**—27 ft. 9½ ins.; rigid wheel-base, 7 ft. 3 ins.

**Tender**—Six wheeled; diameter of wheels, 4 ft. 3 ins.; wheel base, 13 ft.; axles, bearings, 6x11 ins. diam.; capacity of tank, 4,000 Im-

be derived from the pooling system from the company's standpoint. The case was intelligently argued pro and con, without giving undue weight to what might be called mere preference.

The regular engine system, it was pointed out, had a tendency to produce greater care of the machine by the man assigned to it, and in this we were reminded of what we once heard about a cavalryman who was engaged on active service. He said that he could not take too great care of his horse, because the ability of the animal to endure hard campaigning and go through with it successfully was in a way part of his own

performance, and it might be the means of saving his life in an emergency.

The engineer should know better than anyone else how to look after the engine in his charge, so says the report, and where an engine is regularly assigned, a man will, as a rule, be interested enough to give it a good deal of attention that it would not otherwise receive. To the traveling engineer the advantage of the regular engine system is that he can very easily follow up an engine that needs repairs, and obtain more direct information from the engineer who is constantly with it

omical engine load imposes certain limits and restrictions.

There are times when pooling seems to be unavoidable. The success of the system has been demonstrated where special men can be put on to attend to the various classes of repairs. This works out all right at a large terminal, where it would not be practicable at a small one. To specialize work means a large force of repair men, and this would be expensive where few engines were landed.

The report indicates that here, as in other things, circumstances alter cases.

**Tunnel Will Reduce Expense.**

The headings in the new Guymard tunnel, now being built by the Erie Railroad for its low-grade short-cut double-track freight line, came together in the stretch west of the Otisville shaft early last September. The rapidity with which the work has been carried on indicates that the full bore of the tunnel, which is a trifle over a mile in length, will be completed in six months, and the entire tunnel, sheathed and ready for traffic, will be turned over by the contractors by July 1, 1907.

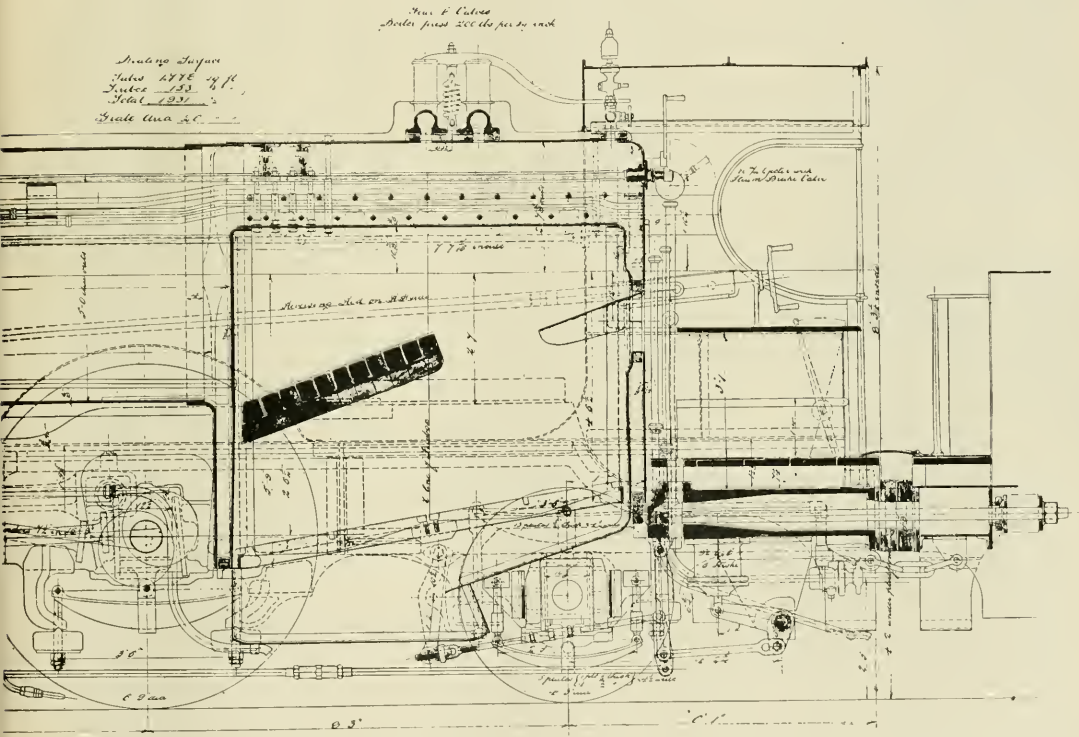

ON THE GREAT CENTRAL RAILWAY OF ENGLAND

Great Central Railway, Builders

than he can from the man who is on the engine only for one trip.

When a division or system is crowded with freight to its utmost limit, when every minute an engine is at a terminal has to be accounted for, then the pooling system appears to be the only way to get the greatest number of miles out of the engine. By this method engines can be kept on the road almost continuously so long as they are in serviceable condition. This seems to be advantageous to the company when they are short of power. An engine should earn every dollar for the company that it can be made to earn, but at this point the econ-

and that the successful handling of conditions is the determining factor in the case. It has been truly said that any line of individual conduct is the result of balancing motives, one against the other, and in the report, though a good case is made out for the regular engine system, the advantages of the pooling method are by no means ignored.

The gold chain worn by judges is a very ancient ornament—probably to remind criminals that they, too, would soon be wearing chains, though not gold ones.

This tunnel connects the Erie main line with the surface road which is being built from the portal of the tunnel west of the present main line to Highland Mills, where it meets the Newburgh branch. While this route does not shorten the distance between New York and Port Jervis, it so materially lowers the grade, something like 150 ft. where the tunnel is cut through the Shawangunk Mountains, so that a material decrease in expense of operation and in time is expected. The entire cost of this Erie and Jersey road will be about \$10,000,000; the tunnel alone will cost about \$2,000,000.

# Railway and Locomotive Engineering

A Practical Journal of Railway Motive Power and Rolling Stock.

Published Monthly by

ANGUS SINCLAIR CO.,

136 Liberty Street, New York.

Telephone, 984 Cortlandt.

Cable address, "Loceng," N. Y. Glasgow, Locanto."

## Business Department:

ANGUS SINCLAIR, President.  
FRED M. NELLIS, Vice-President.  
JAMES R. PATERSON, Sec'y and Treas.

## Editorial Department:

ANGUS SINCLAIR, Editor.  
GEO. S. HODGINS, } Associate Editors.  
JAMES KENNEDY, }  
J. P. KELLY, }

## Advertising Department:

Eastern Representative, S. I. CARPENTER, 170 Summer St., Boston, Mass.

## British Representative:

THE LOCOMOTIVE PUBLISHING CO., Ltd., Amen Corner, Paternoster Row, London, E. C.

## Glasgow Representative:

A. F. SINCLAIR, 15 Manor Road, Bellahouston, Glasgow.

## SUBSCRIPTION PRICE.

\$2.00 per year, \$1.00 for six months, postage paid in the United States, Canada and Mexico. For other parts of the world, \$2.50 or ten shillings. Single copies, 20 cents. Term by Express Money Order, Draft, Post Office Order or Registered Letter. Mailing address can be changed as often as necessary—always give old and new address, and if you subscribe in a club, state who got it up. Please give prompt notice when your paper fails to reach you properly.

Entered at Post Office, New York, as Second-class mail matter.

Copyright by Angus Sinclair Co., 1905.

For Sale by Newsdealers Everywhere.

## Traveling Engineers and Front Ends.

In years gone by, when it happened that subjects for discussion and investigation were scarce at conventions of the Railway Master Mechanics' Association, an unflinching topic of discussion was locomotive spark arresters, and the arrangement of draft appliances. These discussions were always amusing and sometimes profitable to the extent that some of the members received information that they used for carrying out improvements after they returned home. There was no idea, however of making the draft appliances uniform in shape or proportions and a decided belief prevailed that every railroad and even every division required the draft appliances to be arranged to meet its conditions. Several committees had been appointed to investigate and report on the subject of draft appliances and valuable experimental work was done and much valuable information elicited, but the reports failed to influence the practice of the various railroads or to press them towards uniform designs. The earnestly conducted scientific work went for nothing.

In 1901 a movement was inaugurated to carry on a series of tests with locomotive

front ends that would settle beyond peradventure the forms and proportions that would produce the best average results. A strong committee was appointed of which H. H. Vaughan was chairman, and arrangements were made to obtain assistance from the scientific experts of Purdue University, and that exhaustive tests should be made on the locomotive testing apparatus belonging to that institution.

The investigations and experiments were conducted very thoroughly and the work was carried on for several years, a final report having been submitted at the last convention held in Atlantic City in June. Every detail connected with locomotive front ends seemed to be covered and the merits of the different forms of smoke stacks were analyzed. Outside stacks and inside stacks, single draft pipes and double draft pipes had their merits and shortcomings pointed out, while the different forms and position of nozzles received careful attention. To crown all that a standard form of front end was recommended. It was supposed that finality on this question had been reached.

It seems doubtful, however, if this disposition of the locomotive front end question is going to exert greater influence upon the locomotives of the country than those that preceded it. If there is any class of men thoroughly provided with up to date information concerning the value and utility of front end arrangements, it is the traveling engineers of the various railroads. Yet the Traveling Engineers' Association sitting in convention at Chicago last month discussed the subject of "Drafting Locomotives" through two long sessions, making a report of more than 20,000 words. A decided feature of the discussion was that the members considered the Master Mechanics' report on draft appliances as merely an incident in the evolution of this important part of the locomotive. The methods of drafting locomotives were discussed from all standpoints and some of the most intelligent members insisted that arrangements which would make a free steaming engine on one division and with certain kinds of coal would utterly fail under different conditions. There was decided conflict of opinion expressed concerning the value of the lift pipe. The experiments conducted at Purdue University were criticized on the ground that they did not accord with road conditions.

A fairly representative talk was given by Mr. W. J. Randall, of the New York Central, who said:

Referring to the use of the draft pipe, several years ago the New York Central got twenty-three engines of the piston valve type, 23x32 in. stroke, and the stack was 18½ ins. They all had a double draft pipe, and it became in order to

remove the draft pipe from one of the engines, which they did. I went out on the engine the first trip she made, expecting that she would die. I did not think she would steam at all, but, much to my surprise, she steamed equally as well as, and I thought better than, she did before, and the engine ran from that time until she went to the shop, which was in the neighborhood of nine months, and never gave any trouble for steam, except if the flues were leaking a little the blower would not help to get up the steam pressure as quick without the pipe as with it, and, as Mr. Roddy has stated, the netting plugged somewhat more without the draft pipe than it did with. We tried it without the draft pipe in several different types of engines, and in every case the only difference I could see was in the cleaning of the netting. Sometimes the cinders would pack up so near the top of the nozzle that we imagined perhaps the engine in drifting would get cinders.

I do not see how we could have a standard front end. We have had engines from other divisions that I know were perfect steamers on the division where they were running regularly, and they came to our division, working in the same service, drawing about the same tonnage, and we could not do anything with them with the coal we had. They simply would not steam. The front ends would fill up and we had a great deal of trouble; in fact, we could not use them at all. My idea of the proper drafting of a locomotive is that it is necessary to have proper opening in the grate, proper opening in the ashpan and the exhaust nozzle directly in line with the stack, and all those things in the front end absolutely tight, and when we have made all these conditions right and the nozzle of proper size. I think we will have an engine that will steam. I see occasional cases of engines that do not steam, and I find there is some cause for their not steaming. In two or three cases we had engines that failed to steam. The engineer reported and the road foreman or the traveling fireman went out on the engine looking for the defect, and they did not find anything. The engine did not steam. She had a brick arch and she ran several trips before they found what was wrong. The boilermaker got into the fire box with the cold water, 80 lbs. pressure; did not find any defect. But they finally found there was a slight leak in two or three places near the crown sheet, and when the engine was working it would get a leak that would come down over the flue. That was what prevented the engine from steaming. That was remedied and the engine was just as good as she was before. We have found other defects in the front

end which might be called slight, but they prevented the engine from steaming.

I think, as I said before, when the nozzle is made right for our fuel and the engine does not steam, my method would be to cut the cylinder down in preference to bridging the nozzle or putting a bushing in.

#### Pennsylvania Railroad Collision.

A rear end collision happened on the Pennsylvania Railroad a month ago at a station near Philadelphia, by which three passengers lost their lives. As the Pennsylvania Railroad track is operated on an absolute block signal system, it seems very strange that a rear end collision could possibly happen, especially in broad daylight. One express train had been stopped on the main line through the bursting of an air brake hose, and while the trainmen were applying a new hose another express train crashed into the first one, telescoping three cars, with disastrous results. The engineer of the colliding train acknowledged that he ran past the danger signal.

It is interesting to inquire into particulars of the daily discipline which makes an accident like this possible. The road is thoroughly protected by an efficient absolute block system, and the rules require a flagman to be sent back as additional protection when a train is stopped between stations, and yet this accident happened, as many other rear end collisions have happened, under this perfected system of train protection. An engineer naturally asks, where is the weak link of this protecting chain? Where is the defect that renders all precautions futile?

One of the Pennsylvania Railroad officials, in trying to exonerate his company from blame, made very plain the weak point of the elaborate system of train protection. He said that trains run past the cautionary or green signals very frequently every day at a speed of sixty miles an hour and we do not consider that to be necessarily unsafe.

That is the fatal practice. A saying has been current among railroad trainmen that rules are like pie crust, made to be broken, but used to protect the company if any accident happens. It is the daily and habitual violation of important rules that leads to accidents. If engineers are permitted to run past cautionary signals at excessive speed, they soon fall into the habit of using their own judgment in regarding positive stop signals. It is in strictly observing in every day practice the rules governing the protection of trains that safety is assured. Let the practice creep in of ignoring safety appliances, safety appliances become a delusion and a snare. The officials who have been in the habit of overlooking and excusing the

practice of running past signals are responsible for the lives lost in the Pennsylvania Railroad train.

#### Points of View.

"The science of the thing is never to show up against the skyline, because if you do you may get fired at." These words were spoken by the breech-piece mule of No. 2, gun of the First Screw Battery, and overheard by Rudyard Kipling and duly recorded in "The Jungle Book" in one of the stories which he calls "Her Majesty's Servants." To this the troop horse replies, "Fired at without the chance of running into the people who are firing. I couldn't stand that; I should want to charge." Each gives his views of the way to conduct war, and the opinion of each is the expression of how he sees it from his point of view, and each is right as far as his branch of the service is concerned.

After all, one's opinion is very often the result of training and experience, and the point of view is in many cases more or less that which a person is compelled to take. For example, when time can be saved in the smithy by forging parts at one heat, without minutely considering the work of the finishing machine, driving high-speed steel tools along with deep cuts and coarse feeds, does not the view presented look naturally enough as if the greatest economy could be secured by such means?

The mechanical engineer, or chief draughtsman, may feel that he has legitimately scored a point when his drawings call for but two patterns for four or six articles, the necessary reduction in size being secured when the castings are machined, with removal of considerable metal for the smallest size required.

On the other hand, the shop foreman may not share these views, when his tools are compelled to "hog" off metal which he thinks should never have been there, and that time so spent is not time properly used, simply he is able to do the work expeditiously. From the shop foreman's point of view, he, too, is right in carefully considering maximum shop output.

These are some of the problems which confront the general foreman and the works manager. The successful dealing with the question of ultimate economy, which differs from exclusively departmental economy, lies in the consideration of the final cost to be paid by the railway company which has to foot the bills. The general foreman has to take the point of view perhaps midway between the two and regard himself as a manufacturer of goods. He may have to show the machine shop how the finishing process looks from the windows of the black-

smith shop or the foundry, and likewise smith and moulder are all the better for a glimpse of their departments from among the electrically driven machines.

It is all the way through a business proposition, and it may be more economical ultimately in certain instances to have a small stock and finish wastefully on infrequent orders than to carry what supply houses call a full line of all sorts of material, part of which may not be used for years.

On top of all this there sometimes comes the necessity to provide for an emergency call for repair material which takes half finished work out of the machines to give preference to rush jobs, and brings overtime to the front. This, in a word, is the ability to get out of a tight place.

The effort to get at the comprehensive point of view means the more or less successful approximation to the happy means in shop administration and there is no better way to adjust the viewpoint than in the interchange of opinions, and of thus getting hold of other people's ideas and experiences. To this end the work of our various mechanical department associations and railway clubs cannot be too highly commended with their full reports, free discussions and published proceedings, which latter at least are within the reach of all. The educational effect of getting together is now almost universally recognized in the railway world, and it may be said in this as in other departments of secular instruction, "The schoolmaster is abroad."

#### Free Technical Schools.

The liberal management of the Southern Pacific Company was never shown to better advantage than in the movement inaugurated by them last month in establishing a free technical school in Nevada. Mr. J. F. Dunn, superintendent of motive power, had been negotiating with President Stubbs, of the Nevada University, for some time, and the negotiations have resulted in the opening of a technical school at Sparks, Nev. The apprentices attending this school will receive full pay for time spent in the school the same as when they are at work in the shops.

The school will be under the charge of Professors Scrugham, Baker and Freeman of the university. There will be two classes, one for apprentices, and the other for machinists, car men and mechanics. All the shop foremen are being consulted by the professors as to the subjects to be taught, and the special lines of instruction to be taken up, the principal idea being to make the courses useful to the men taking the lessons. Reports will be regularly made to Mr. Dunn's office. These will show the progress being made by the students.

It need hardly be said that young men of merit will thus have an opportunity to bring their qualifications prominently before the railroad officials. The enrollment is already very large, and other schools are likely to be established in other States through which the Southern Railway passes, and it is to be hoped that the example set by President Harriman of the Southern Pacific will be followed by other roads. The Central Railroad of New Jersey has had a technical school in operation for some time with very satisfactory results, and it is particularly gratifying to see that in the case of the Southern Pacific the State University authorities are co-operating heartily with the railway company.

#### British Railway Disasters.

The reputation which the British railways have earned for safety has been rudely shaken by the recent disasters occurring on two of the best managed roads in England. It might be supposed that the lesson learned a few months ago at Salisbury, on the London and South-Western line, would have excited a desire for caution in the matter of fast running at curves, but it seems that the mania for high speed required that this second lesson should be impressed on the officials and employees by whose methods such appalling loss of life has occurred. The British press assume that there is a mystery about these disasters which the admittedly high speed and the sharpness of the curves do not altogether account for. To our minds, the real mystery lies in the unaccountable reason why the disasters did not occur before now.

The Grantham disaster is perhaps more pointed in the lesson that it teaches than its predecessor. In the Salisbury tragedy it was a case of derailment at a sharp curve when the train was running at a speed nearly twice as fast as is deemed safe in such circumstances. The more recent disaster is a different story. The train was due to stop at Grantham at about 11 P. M., but instead of pulling up at the platform, it rushed past the station at a speed estimated at over 60 miles an hour. Had the road been perfectly clear all would have gone well, but it so happened that the points of a cross-over track were open, so that the express at its highest speed took this road. The engine kept on till it reached the point curving into the straight line, when it left the rails, breaking down the parapet of a bridge. The destruction was of the most spectacular kind, the engine tearing up the rails for over 100 yards and picking up a rail which found its way between the axles and the boiler, and finally the engine fell over on its left side. Four of the cars rolled down

the embankment literally breaking to pieces. In the wreck were 12 passengers killed and about 20 severely injured. The escape of many seems miraculous, three of the cars remaining on the track.

The cause of the disaster is not far to seek. A long gradient approaching Grantham gives the train great momentum which the early and judicious application of the brakes can restrain under ordinary conditions. In wet weather the application of the brakes is necessary a considerable distance from Grantham. The evidence shows that the engineer had either forgotten or misjudged his distance. The brakes were not applied in time, if at all.

The desire to make up a few minutes' lost time gradually becomes a passion in the minds of many competent engineers, and the growth of the passion is often helped rather than hindered by the attitude sometimes assumed regarding such matters by the officials of the road. This is true on both sides of the Atlantic.

In each of these accidents both engineers and firemen are dead, and it need not now be the subject of prolonged comment what they failed to do. From these sad lessons, caution should be learned. The desire for speed has been overreached. The lesson inculcated is one that bears out the old Latin proverb, and it is applicable to American railways as well as on British lines—"Vincit qui curat"—He conquers who takes care.

#### Exhibition of Safety Devices.

We have received from the president of the American Institute of Social Service a notice of their intention to hold an exhibition of devices for safeguarding the lives and limbs of working men and women under the ordinary conditions of life and labor to which the general public is exposed. The exhibition will be held in the American Museum of Natural History, in New York, in January next.

Among other things, the Institute of Social Service, through their president, Mr. Josiah Strong, says:

"This will be the first exposition of the kind in this country, and it is surprising to note how far behind other nations we are in this respect.

As far back as 1889 there was a German Exposition for the prevention of accidents. In 1893 an exposition of this nature was held in Amsterdam, and since then there have been several similar expositions in continental Europe and in Canada.

As an outgrowth of these national movements there have been organized several museums of security; one at Vienna in 1890, one at Amsterdam in 1893, one at Munich in 1900, one at Berlin in 1901, and one at Paris in 1905, and Rus-

sia, which we are inclined to look upon as semi-barbarous, has recently established a museum on a large scale in Moscow.

That these expositions and museums have been of real value to their respective countries is evinced by a comparative study of the number of accidents in Europe and in America, which shows that for the same number of men employed in a given trade, we have from two to nine times as many accidents as they have in European countries.

The perfection of modern firearms rendered the late conflict in Asia exceptionally bloody; and yet it can be shown that without reasonable doubt the casualties of our industrial army in the United States are at least fifty per cent. greater every year than the number of killed and wounded in both the Japanese and Russian armies.

Such conditions can exist only through general ignorance of their reality, and it is for the purpose of educating the public to an appreciation of the actual situation and the means of its improvement that the Exposition of Safety Devices is to be held.

The interest of manufacturers generally is solicited, as well as that of organizations whose special function is to improve the conditions of labor, and a widespread response is looked for to this request for representation in the nature of photographs, descriptive drawings, models, and as far as possible, the devices themselves in actual operation.

Requests for information regarding space should be made to Dr. William H. Tolman, Director, 287 Fourth Avenue, New York."

In this connection we may say that recent legislation in Great Britain places the responsibility for injury to operatives in factories and workshops on the employer. This legislation is one of the fruits of workmen joining together to send to Parliament representatives of their own class, who place their constituents' interests above party allegiance. The effect of this law will not only cause greater care to be taken to avoid needless accidents, wherever men or women are employed, but the production and use of safety appliances will be enormously stimulated for the same reason. We believe that the proposed exhibition of safety appliances in the United States will be a most important and beneficial object lesson to the whole country, and safety appliances in connection with railway work will no doubt be one of the features of the exhibition.

#### The Future Engineman.

The keynote and the kind of keynote with the true ring about it was struck by the committee which presented the



paper on "The Future Engineman, and the Best Methods for Increasing His Efficiency and Raising His Standard," at the recent meeting of the Traveling Engineers' Association. Mr. D. L. Eubank was chairman of that committee. The report was short, pithy and to the point.

The keynote was the importance of properly starting the firemen and the care of the young engineers. The report recognizes the truth, old as the human race, that you can't start wrong and end right. The committee believe that too little attention is given to the younger element both firemen and engineers, immediately after their employment or promotion. The newly appointed fireman is given a few days' training with an experienced man, in which time possibly tricks are played on him, instead of devoting the time to serious instruction. After he has been assigned to duty on a yard engine, no further attention is paid to him unless a complaint is made concerning him.

What has been said about the new fireman, the report practically says about the young engineer, but he is usually criticized by the older element on the road, because he does make as good a run or as intelligent report as men of greater experience. It is no discredit to these younger men that they are the children among the employees. The responsibility to help, guide and encourage them is laid at the door of the older men who often do the criticizing.

The report points out that the care of men at terminals is important. Good, clean rest rooms should be provided which in themselves encourage cleanliness among the men. Reading rooms and libraries might be established where men could not only be entertained, but would have a chance to keep themselves posted on the leading topics of the day, mechanical and otherwise.

In the matter of dealing with the railroad duties of the beginners the report calls attention to the fact that they should be encouraged to seek advice and not held off at arm's length until some mistake is made. A word of friendly advice, given in the right spirit and in the right way, will often strike a chord, or make an impression that will last a lifetime.

#### Book Notices.

The Report of the Proceedings of the Thirty-ninth Annual Convention of the American Railway Master Mechanics' Association, held in Atlantic City, N. J., June 18, 19 and 20, 1906, has come from the press. The book contains 569 printed pages and is uniform in binding, etc., with the "Proceedings" of former years. The book can be had on application to this office. Price, \$1.50.

Proceedings of the Air Brake Men's

Association, 1906. Last month we made mention of this book, but quoted the price at the figure heretofore charged by the association. We have recently been informed by the secretary that inasmuch as the 1906 proceedings are larger and more expensive to make than former proceedings, and as this issue contains an unusual amount of the latest information on the Westinghouse Air Brake Company's new triple valve, the E T equipment, and the new engine equipment of the New York Air Brake Company. For these reasons it has been found necessary to advance the price of the 1906 book to \$2.00 for the leather covered copies, and \$1.50 for paper covers. We supply copies on receipt of the price.

Brazing and Soldering. By Jas. F. Hobart. Published by the Derry-Collard Company, New York. Price, 25 cents.

This is one of the practical paper series. It has 33 pages, containing a lot of information, and has 16 illustrations, which help to make everything clear. It takes up soldering, hard and soft, and a perusal of the pamphlet cannot fail to be helpful to those who want to learn something on the subject.

Management of Electrical Machinery. By F. B. Crocker and S. S. Wheeler. Published by D. Van Nostrand Company, New York, 1906. Price, \$1.00.

This book, now in its sixth edition, is an enlarged and revised edition of Practical Management of Dynamoes and Motors, and is a compilation made of articles which appeared in the Electrical Engineer in 1901 and 2. A large amount of new and amended matter has been introduced, such as the management of alternating current generators, and motors, both single and polyphase, also railway motors.

Cost of Locomotive Operation. By George R. Henderson. Published by the Railroad Gazette, New York, 1906. Price, \$2.50.

In this book the author goes into the cost and value of materials with the expense for handling and caring for them. The returns obtained by methods of using the different supplies, the effect of grade, speed, loading, etc., upon the consumption of both material and labor. The combined effects upon all the items which go to make up operating expenses. The book contains 192 pages.

Railway Organization and Working. By Ernest R. Dewsnup. Published by the University of Chicago Press, 1906. Price, \$2.00.

This book is a compilation of a series of special lectures delivered before the university classes in railway transportation from the fall of 1904 to the spring of 1906. The lectures were delivered by practical railroad men who were invited

by the university to deal in a practical way with the subjects on which they were experts. For example, Car Distribution and Supervision of Fast Freight, was taken up by Mr. J. M. Daly, car accountant of the Illinois Central. Railroad Signaling, by C. A. Dunham, signal engineer of the Great Northern Railway. Classification and Types of Locomotives, by Mr. C. A. Seley, mechanical engineer of the Rock Island. The Purchasing Agent, by Mr. E. V. Dexter, purchasing agent of the Chicago & Alton. These are examples taken at random from the table of contents. There are twenty-five lectures covering all the departments of railway operation from a business standpoint. The book being a compilation of scattered lectures, lays no claim to a balanced treatment of the whole subject of railway transportation, but the men who delivered the lectures were railroad men.

#### Colonel Long's First Locomotive.

In 1830, Colonel Long, president of the American Steam Carriage Co., built in Philadelphia a locomotive which had a boiler with a combustion chamber in the middle, but otherwise it resembled the improved English locomotives. In working order the engine weighed about 8,000 lbs. It was tried very exhaustively on the Newcastle & Frenchtown Railroad, but its performance resembled that of a pioneer Scottish locomotive, which the builders wished to recommend through the influence of Napier, a celebrated engineer. Napier had been invited to witness the test of the locomotive which had been designed by an ambitious amateur. The promoters of the engine succeeded in bringing Napier into the presence of capitalists; but when the attempt was made to have the engineer testify in favor of the engine's performance nothing was forthcoming but a succession of protesting grunts. Losing patience the inventor exclaimed, "You must admit that you saw the engine running." "You may call that running," replied Napier, who stuttered, "all I saw was you fellows sho-sho-shovin' her."—From Angus Sinclair's "Development of the Locomotive Engine."

#### Engine and Passenger Smoked.

Smokers had no toleration on English trains in early days. It is said that a certain foreign gentleman presumed to smoke his cigar in a railway carriage, was warned to desist, but continued to take a sly whiff while the train was in motion. A passenger in another compartment smelt the penetrating odor of the weed and complained to the guard that somebody on the train was smoking. The guard apparently was not able to successfully

call a halt on the smoker, and the aggrieved non-smoker brought suit and recovered damages against the company.

#### Patent Office Department.

Boiler attachments seem a very favorite theme for our inventors to work upon. This arises from the fact that a greater degree of variety can be obtained in matters that are merely subsidiary than in prime factors. The working parts of the locomotive have reached a degree of perfection that has left the inventor little room for improvement. The selections from last month's

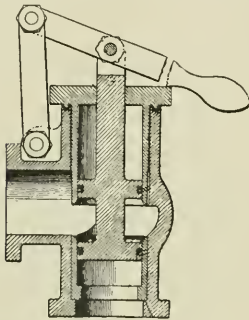

BLOW-OFF VALVE

report show considerable ingenuity, and we select a few of the most notable for illustration and description.

#### BLOW-OFF VALVE.

Mr. H. F. Weinland, Springfield, Ohio, has patented a blow-off valve, No. 832,178. The valve is suitable for use on steam boilers, and comprises a casing having an inlet passage and a seatless outlet passage, and a piston valve fitting the outlet passage, adapted to close the passage by peripheral contact with the wall, and movable into and out of said outlet passage at its inner end, the inner end being flaring, whereby erosion of the edges of the valve is avoided. A removable bushing is fitted in the upper portion of the transverse passage. A lever that may be adjusted to any length is adapted to readily opening or closing the valve.

#### BRAKE SHOE.

A variety of brake shoes have been invented and patented by Mr. J. F. Morrison, Chicago, Ill., 832,145-6. The chief features of the brake shoes are a body, with a cast malleable iron shell inclosing the body, and ribs on the sides of the shell making locking engagement with the body. One of the designs comprises a shell having openings therein, a body pressed or cast in the shell and openings, and inserts of different material from the shell and body and held in place in the body.

#### LOCOMOTIVE.

A design for a locomotive having several novel features has been patented by Mr. Emilio M. Canto, Santiago, Chile.

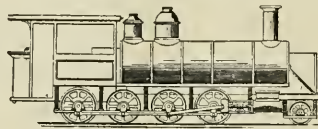

LOCOMOTIVE SPRING ARRANGEMENT

As the illustration shows, the locomotive is furnished with a platform resting on heavy spiral springs interposed between the platform and the body of the locomotive. Flanged wheels are mounted on the forward and rear portions of the frame and smooth surfaced wheels are mounted between the flanged wheels, all the wheels being rod connected. The frames are so constructed that they possess a large degree of flexibility in rounding curves.

#### SPARK ARRESTER.

A spark arresting device has been patented by Mr. W. C. J. Hall, Quebec,



SPARK ARRESTER

Canada, No. 832,188. It is attached to the top of a locomotive smoke stack, and consists of a hood formed of wire mesh supported a short distance above the top of the stack and separated therefrom by an open space, and a cinder basket carried by the stack adapted to receive the sparks or cinders striking upon and falling from the hood. The top of the hood is of an inverted saucer form and is securely attached by bolts to the stack.

#### MOTOR TRUCK.

Mr. G. S. Gundersen, Columbus, Ind., has patented a motor truck, No. 831,948. The truck is furnished with suitable axles and wheels, with a frame mounted by means of bearings between the

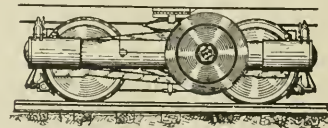

RAILWAY MOTOR TRUCK

wheels, an engine mounted on each side of the frame outside of the wheels with piston rods connecting the pistons of the engine at each side to a crank shaft and means for transmitting power from the crank shaft to an axle.

#### PISTON PACKING.

Mr. W. Sudekum, Nashville, Tenn., has patented a metallic rod packing, No. 832,434. The packing consists of a set of oppositely disposed concave follower rings, of a spring between the cylinder head and one of the rings for holding them outwardly from the cylinder head. A set of soft metal packing rings is confined between the followers, the rings being split at one side and having an undercut groove at the opposite side with their inner walls overlapping the groove.

#### CAR VENTILATOR.

Mr. C. E. Mandeville, Kansas City, Mo., has patented a car ventilator, No. 832,229. The device consists of a pair of conical drums carried beneath a car, with their enlarged ends facing each other and cut in oblique section to form elliptical mouths, each drum being so arranged that the larger axis of its elliptical mouth will extend horizontally. A mesh covers each drum mouth and a main exhaust tube extends from a point in each cylinder through the mesh mouth covering. Rearwardly surging doors permit the graduated passage of air through the cylinders.

#### STEAM EXPANDER.

A contrivance for expanding the exhaust steam as it passes into the smoke stack has been patented by Mr. C. A. Gilmore, McComb, Miss., No. 831,785. It consists of a steam nozzle arranged to discharge the exhaust steam into the smoke stack, where a conical steam expander located within the smoke stack

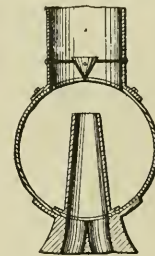

EXHAUST SPLITTER

deflects the steam into the widened stack. There is a pair of supporting rods arranged at right angles to each other and passing through the steam expander and through the walls of the smoke stack, holding the expander securely in place.

Railroads, with wooden rails, were first used in 1672 at collieries; cast iron rails were first used in 1738. An iron rail nailed to wooden sleepers was first used in 1776, and the present idea of rails and wheels adapted to each other was invented in 1789.—Journal of Education.

# Our Correspondence School

In this department we propose giving the information that will enable trainmen to pass the examination they are subjected to before being promoted. If any of our students fail to understand any part of the instructions, we will gladly try to make them plainer if they write to us. All letters intended for Our Correspondence School ought to be addressed to Department E.

## Third Series—Questions and Answers.

140. How many minutes apart should passenger trains keep, going in the same directions, when no form of block signal is used?

A.—They should keep at least five minutes apart, unless special instructions govern this condition.

141. How far apart should freight trains keep, going in the same direction, when no form of block signal is used?

A.—They should keep at least five minutes apart except in closing up at stations unless special instructions govern this condition.

142. How much time should a train have, leaving a station, expecting to meet or be passed at the next station by a train having the right of track?

A.—It must have time enough to run to the next station at the usual rate of speed for trains of its own class, and in addition, it must have time enough to be in the siding clear of the expected train by not less than five minutes.

143. In case you fail to get your train entirely clear of the main track by the time required to clear a train of superior right, what must be done?

A.—A flagman must immediately go ahead when expecting a train going in the opposite direction, or he must go back when following train is expected to pass you. He must have stop signals and go away a sufficient distance to insure complete protection. When conditions require it, he must place two torpedoes on the rail when called in.

144. May a train arrive at a station in advance of its schedule arriving time, when shown? If so, under what circumstances?

A.—No, it must not. In case a train was in such a position that it might be caught between stations when a timetable changed, the train should stop at the last station reached before a new time-table takes effect and leave such station on the new time.

145. May a train leave a station in advance of its schedule leaving time?

A.—No.

146. When are trains of the same class to stop at schedule meeting or passing points?

A.—Trains must stop at schedule meeting points if the train to be met is of the same class, unless the switch is right and the track clear.

147. At what point should the train be stopped?

A.—Trains must stop clear of the

switch used by the train to be met in going on the siding.

148. In case the train that should be met or passed is not at the schedule meeting or passing point, how would you be governed?

A.—A train should not stand on the siding for an unreasonable length of time, but should communicate by telegraph with the dispatcher for the purpose of seeing if there is a chance of getting orders against the delayed train.

149. At schedule meeting points and meeting points made by time order for trains of the same class, what is required of the train having right of track, if train to be met has not arrived?

A.—When the expected train of the same class is not found at the schedule meeting station, the superior train may proceed, but must approach all sidings

appearance on the road or along side which may indicate danger and be governed by the standard code rule 106, which says: "In all cases of doubt or uncertainty, the safe course must be taken and no risks run."

153. What must be ascertained before leaving junctions, terminals, or other starting points?

A.—Before leaving a junction, terminal or initial station a train must ascertain whether all trains due, which are superior or of the same class, have arrived or left.

154. How would you ascertain this?

A.—By examining the register book which is kept at the station for that purpose.

155. How do you ascertain the location of register books?

A.—Answer in accordance with spe-



BUSY, BUT JUST TIME ENOUGH TO LET THE CAMERA CATCH ON

prepared to stop, until the expected train is met.

150. What is required of a train starting from a station or junction point having right of track when an opposing train of the same class is due at such point and has not arrived?

A.—If a train of same class, but moving in the inferior direction, has not arrived the train having right of track may proceed but must approach all sidings prepared to stop until the expected train is met.

151. How should all trains approach end of double track, junctions, railroad crossing at grade and draw-bridges?

A.—They must be prepared to stop, but may proceed if signals and switches are right and track clear. If the law requires a stop to be made, they must stop.

152. What is required of engineers in passing unsafe places, bridges and tunnels where speed is to be reduced?

A.—They must keep a sharp lookout for signals and be prepared to stop. They must look specially for any ap-

cial rule of the railway company.

156. When a flagman of a freight train goes back to protect the rear of his train, who must take his place?

A.—In case of freight trains the next brakeman takes the place of the man who goes back to flag.

157. When the flagman of a passenger train goes back to protect the rear of his train, who must take his place?

A.—In case of passenger trains, the one to take his place is designated by special rule of the railway company.

158. What is necessary when a train is detained at a usual stop, or is stopped at an unusual point, by accident or otherwise?

A.—It must be protected by flagmen and the train dispatcher communicated with as speedily as possible.

159. If from any cause the speed of a train is reduced, who is held responsible for protecting the rear of train?

A.—Both conductors and engineers are responsible for the safety of their train.

160. When it is necessary to protect

the front of train, upon whom does this duty fall?

A.—Answer in accordance with the special rule of the railway company.

161. What is he required to do?

A.—He is required to go forward with stop signals, a distance sufficient for the full protection of the train; when recalled, he may return, first placing two torpedoes on the rail when conditions require it.

162. Suppose the fireman is unable to leave his engine, who is to perform this duty?

A.—Answer in accordance with the special rule of the company.

163. Is engineman required to know, and he is held responsible for fireman or head brakeman performing this duty?

A.—Yes.

164. Is conductor also required to know that his train is protected in both directions?

A.—Yes.

165. When flagman is recalled and there is not a clear view for a quarter of a mile (8 telegraph poles) from rear of train, what is required?

A.—Two torpedoes must be placed on the rail by the flagman.

166. What is necessary on the part of flagman in foggy, stormy or snowy weather, or in vicinity of curves or on descending grades?

A.—He must place one torpedo on the rail in addition to displaying stop signals.

167. Do you understand that exposure to rain or moisture impairs the explosive qualities of torpedoes?

A.—Torpedoes should not become defective owing to exposure to moisture or rain.

168. How must trains approach watering and coaling stations?

A.—They must approach with caution, keeping a sharp lookout for signals, etc., and be prepared to stop.

169. How should trains approach yard limits?

A.—They must be prepared to stop and keep a sharp lookout for signals, etc.

tion between our shoe soles and the sidewalk we would be continually in the same state of mind as when we try to walk on glare ice, and most of us would cut "stars" much of the time.

Having friction always with us we must have some way of measuring it, and so we have adopted what is called "the co-efficient of friction" for this purpose. Suppose we have a block of iron that weighs 10 lbs. on a table with an iron top. We hook a spring balance and pull it along by the spring balance, as shown in the figure. The spring balance

seats and journals are cut in consequence.

For a plain example of this let us take an unbalanced slide valve, say, 10 ins. wide by 18 ins. long, or having 180 sq. ins. altogether. Say the valve weighs 50 lbs. and the steam pressure is 150 lbs. per square inch. Here we have 150 lbs. pressure on every one of the 180 sq. ins. or a total of 27,000 lbs. to add to the 50 lbs. that the valve weighs. Calling the co-efficient of friction .3 we multiply 27,050 by .3 and get a total of 8,115 lbs. pull required to move the valve on the seat. In reality this is reduced by the back pressure of steam under the valve at the exhaust port and the compression at the other steam port, but it leaves a good healthy pull just the same to be overcome as best we may by lubrication. This is what led to the adoption of the balanced valve which is so well known now and which simply means that it balances or takes off the top of the valve, about 60 per cent. of the pressure due to the steam pressure.

Calling the valve the same size and the balance 60 per cent., we have only 40 per cent. left to calculate for in the pull to be given. Forty per cent. of 27,000 is 10,800 lbs., and with the co-efficient of .3 this gives us 3,240 lbs., not allowing for the weight of the valve itself, which, of course, cannot be balanced in this way. When we realize the power required to move the valve when under steam pressure we see why it is best to make the valve stems and other parts of the valve motion stiff, as they have much work to do. We also see that a dry valve adds greatly to this work and that this should be avoided. We have all seen cases where a dry valve would stick so that when the valve was being pushed forward the valve gear sprung enough to allow the valve to remain on the seat and not open at all. The result is a three legged exhaust at times which sounds exactly as though there was a loose eccentric. When the valve motion pulls back the valve comes with it, as then the rods are in straight tension (have a straight pull) and the valve moves as usual in spite of being dry. It would be interesting to know the power required to move the valve under these conditions.

The friction of the bearings, such as the axles, and in fact all which turn in boxes, is sliding friction the same as the valve but is not quite so easy to explain. The valve or a solid block is a plain straight pull which can be measured by a spring balance, but it is different with the axle turning in the bearing. Here we have the weight to consider as in the other case, but we also have the question of leverage as it makes a difference where we take hold of the axle to turn it. In the case of a locomotive the main question to consider is, how

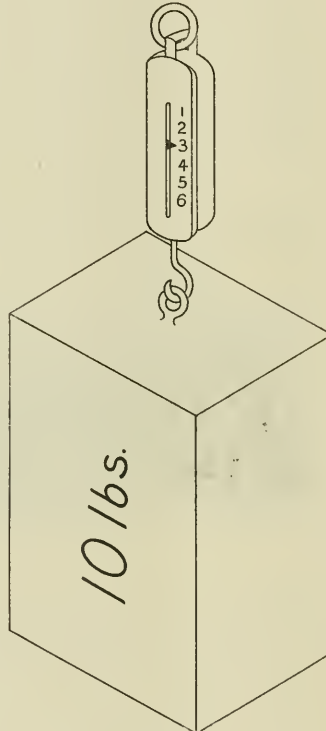

SPRING BALANCE AND WEIGHT

will perhaps show 3 lbs., indicating that a pull of 3 lbs. was necessary to move the iron on the table.

This means that 3 lbs. will move 10 lbs. and we call the co-efficient .3, because, by multiplying the weight to be moved by the co-efficient we get the power required to move it. As a matter of fact, the power required to move the 10 lbs. block of iron on the iron table might be more than 3 lbs. unless it was oiled; in this case it might be less than 3 lbs., perhaps  $2\frac{1}{2}$  lbs. This shows right at the start the value of a little oil in the right place, but it often happens that there is a decided difference of opinion as to what is the right quantity and many valve

### Calculations for Railway Men.

BY FRED H. COLVIN.

#### FRICITION.

Friction is one of the results of the law of gravitation in so far as it is caused by the weight of a body resting on any surface, resisting motion as we try to push it along. When friction occurs from a bearing being too tight and pinching the shaft or axle, that is a different matter.

But the friction that gives us the most trouble is that due to weight, and yet it is only on account of this that we are able to walk along the street in comfort, for without the fric-

much of the power developed is used up in internal friction—in other words, in moving itself, as this power is wasted so far as useful, paying work is concerned.

Figures are of not much account in a case like this and perhaps one of the most useful results of the elaborate tests made on the great testing plant of the Pennsylvania Railroad at St. Louis, Mo., is the facts regarding the friction of the locomotives themselves.

These show that the engine friction varied from 18 to 40 per cent. with an average of from 25 to 30 per cent., which seems much higher than we usually suppose. This is most easily understood when we consider that, if the locomotive is developing 1,200 h.p., 480 h.p. is used or wasted, in moving the engine itself and without pulling an ounce of paying load.

It is safe to suppose that the engines under test were well lubricated, and when we find from experiments that the friction of unlubricated journals is about double that of well oiled journals, we wonder how much power is required when the oil supply is not as much as it should be. This is too often the case on the road and we cannot help believing that much power is wasted in this way that might be saved by a little more liberal use of oil.

The friction of the valve given at the beginning is the co-efficient for dry surfaces and not for lubricated, and is what we find if a valve runs out of oil. With lubricated surfaces, the reference books give the co-efficient as from .07 to .15, or from one-quarter to one-half the figures given at the start. Whichever we decide on as being right, it is self-evident that it means dollars in pocket to have it as low as possible.

## Questions Answered

N. Y. NEW ENGINE BRAKE ON GRADES.

(100) D. F. B., Omaha, Neb., writes:

We have some long, heavy grades on our line and we control the trains on them with air. On one of our long grades we attempted to let a train down with an engine that had the New York new engine equipment, but found that we had to resort to other means to control the train before reaching the foot of the grade. Will you kindly explain why the new brake will not do the trick as well on grades as the older New York equipment? A.—On long, heavy grades time is an important factor, and to control trains safely with air while descending, it is necessary to recharge the auxiliaries quickly after each release to maximum pressure in order to have full braking power always

available. Assuming that all parts of the equipment in question were operating as intended, we should incline to the belief that the pressure controller was the cause of your failure, since it does not allow the excess pressure in the main reservoir to flow into the brake pipe. This action of the pressure controller causes a slower recharging of the auxiliaries than is had with the older equipment, which is a serious objection in heavy grade work. A more satisfactory answer to your question could be given if you had stated the length and the per cent. of the grade, the number of cars in your train, whether loaded or empty, and how many pressure retainers you were using; also the brake pipe pressure, whether 70 or 90 lbs.

BROKEN EQUALIZERS.

(101) J. E. H., Charlestown, Mass., writes:

1. What way does the equalizer go on a standard engine with overhung spring rigging, if you break the front spring? A.—Under these circumstances, the equalizer would tilt with the end next the broken spring up.

2. Suppose the springs were underhung? A.—The end of the equalizer next to the broken spring would go down.

3. If the equalizer was between frames? A.—Figure this out for yourself in the light of the two preceding answers and let us hear from you. Remember the boiler, etc., rests on the frames, the axle boxes hold up the weight of the engine, and the spring rigging is interposed between the two.

HORSE POWER OF A BOILER.

(102) J. C., La Junta, Col., writes:

What is the best rule for calculating the horse power of a boiler? A.—We would not like to venture an opinion as to the best rule, but a common rule is to divide the number of square feet of heating surface by 12, and the result will be the rated horse power. A boiler which evaporates 34½ lbs. of water into steam from and at 212 degrees per hour is said to be equal to a horse power of work. See article on this subject on page 244 of the June issue of RAILWAY AND LOCOMOTIVE ENGINEERING.

PUMP GOVERNOR DEFECT.

(103) J. F. W., Cincinnati, O., writes:

What defect would cause the following trouble: Take a high-speed brake, 110 lbs. train line and 130 lbs. main reservoir pressure, governor stops pump at 130 lbs., but by throwing your brake valve handle to full release the governor does not stop the pump until your train line and main reservoir equalize at 140 lbs.? A.—Assuming that your high speed equipment has the low pressure governor top piped to the reversing cock of the double feed valve, so that when the latter is turned to cut out

the low pressure feed valve it also cuts out the low pressure governor top, the following could cause the action you describe: The low pressure feed valve is probably adjusted for 110 lbs., the low pressure governor top for 130 lbs., and the high pressure governor top for 140 lbs. The low pressure feed valve and governor top are cut in, and they operate, with the brake valve handle in running position, to control the main reservoir and the brake pipe pressure at 130 and 110 lbs., respectively, as you state. Moving the handle of the brake valve to release position cuts out, practically, the low pressure feed valve and governor top; then the pump can run until the main reservoir has 140 lbs. pressure.

WESTINGHOUSE AND N. Y. IN EMERGENCY.

(104) W. H. F., West Albany, N. Y., writes:

If a freight train, say, of from 45 to 60 cars, was equipped with New York triple valves and was running at the rate of 20 miles per hour when an emergency application was made, how much farther would it run than if it had all Westinghouse brakes? A.—The difference in the distances, if the train was loaded and the track level, would be about 50 ft. in favor of the Westinghouse brakes. If it should happen that a service application had just been started before the emergency was wanted, then the differences given above in favor of the Westinghouse brake would be about 110 ft. These differences in the stopping power of both brakes were determined by actual test. At higher speeds, or on down grades the difference in favor of Westinghouse brakes would still be greater.

HOT CRANK PIN.

(105) C. L., New York, writes:

I have frequent trouble with crank pins heating even when the brasses are perfectly loose and well fitting. What is the cause of the heating? A.—The brasses could not very well be loose, and well fitting at the same time. When too loose they are readily sprung or distorted which would cause heating. Other causes are when crank pins are not large enough, or the lubrication is of poor quality, or by foreign matter getting into the bearing. The material has also much to do with the tendency to heating.

CRANK PIN AND PISTON.

(106) J. R. C., West Albany, N. Y., writes:

How much faster does the crank pin travel than the piston. A.—More than one-half faster, or in the ratio of 1 for the piston to 1.5708 for the crank pin. This can readily be determined by observing that the piston makes a full stroke both ways for one revolution of the crank pin. One stroke of the pis-

ton is equal to the diameter of the circle described by the crank pin, which, multiplied by 3.1416, gives the circumference of the circle.

#### EQUALIZATION IN DRIVER AND TENDER CYLINDERS.

(107) J. S. F., Jackson, Mich., writes: The driver engine truck and tender brake cylinders, as I understand the ET equipment, get their air from the distributing valve, and it seems to me, on account of the brake cylinders being so far from this valve, that the full cylinder pressure in emergency applications would be considerably slower than with the triple and auxiliary reservoir. How about this? A.—When the plain triples and auxiliaries are used the maximum equalization obtained in the brake cylinders is about 50 lbs., assuming brake pipe pressure used is 70 lbs.; and it is true, this is obtained quickly.

With the ET equipment the maximum cylinder pressure obtained in emergencies is about 60 lbs., and the pressure, up to 50 lbs., is had just about as quickly with the ET brake as with the other, notwithstanding the cylinders are located farther from the source of supply. When the application valve opens, the main reservoir supplies the air to the brake cylinders at a constant driving pressure of 90 lbs., which makes the pressure mount up rapidly even though the brake cylinders are located some distance from the distributing valve.

#### LINK SADDLE STUD.

(108) H. W., Scranton, Pa., writes: What is the reason that the stud on which the link hanger is attached is not on the center of the link, and what method is used in obtaining its correct position? A.—The position is generally found by laying out the complete valve gear in its various positions upon the drawing board. The position can more quickly be found by experimenting with an adjustable valve model. In repair work the best method is to hold the link saddle by clamps and by marking the positions of the valve at various points the correct position can be reached. The necessity for removing the link saddle stud some distance from the center of the link is caused by the angularity of the main rods, which makes the piston travel unevenly, and also by the angularity of the eccentric rods, which makes them move the ends of the link unevenly, and in the case of the link motion the alteration of the point of suspension gives a satisfactory compromise result.

#### NEW YORK, NO. 5, PUMP BROKEN STEAM VALVES.

(109) F. C. C., East Buffalo, N. Y., writes:

On nearly every New York, No. 5, pump that I have handled, I find the steam valve on the high pressure side

broken. Can you give us a reason for this? A.—It is probably due to the hard service which the valve has to stand. When this pump is run with 200 lbs. steam pressure the pistons impose some very heavy strains on the reversing valve rods, and on the steam valves, especially on the high pressure side. When the pump is working vigorously against a main reservoir pressure of 100 or more pounds, the failure of a final discharge valve to seat permits main reservoir air to follow the air piston, and this practically adds this pressure to the steam pressure that is driving the piston. When the piston driven with the combined steam and air engages the reversing rod and steam valve, it delivers a very heavy blow, and this repeated at each stroke, causes the reversing rods and steam valves to break.

(110) J. R. C., Meadville, Pa., writes:

We are experiencing a lot of trouble from failures of the New York, No. 5, duplex pump; the reversing rod seems to give out. Can you give us any reason why there should be such frequent breakage of this particular part of the pump? A.—In the No. 5 duplex pump there is a flat slide valve for admitting steam to and exhausting it from the cylinders.

Where steam pressure used is 200 lbs., or greater, the load on the valve is very heavy, and when the tappet plate engages the reversing valve rod it pulls it almost instantaneously, and this acts as a severe blow to the rod, which, no doubt, causes it to fail after a short period of service.

#### Fraudulent Dipsomania Cures.

For some reason or other certain fraudulent concerns that pretend to cure the alcohol habit find a large number of their victims among railroad men. When persons come to love intoxicating beverages not wisely but too well and have lost the will power of resistance they become easy victims of the quacks who pretend to cure the disease of alcoholism. Why railroad men should be conspicuous victims of the quack doctors is not easily understood unless it be that the rules against drinking are enforced more rigidly in railroad service than in any other.

A crusade against patent medicine quacks and vampires who are ready and willing to poison people under pretense of curing diseases and evil propensities that they never influence in the least, has been vigorously pushed by Samuel Hopkins Adams in Collier's Weekly. The articles ought to be read by every person likely to waste money on pretentious characters. A curious thing about the pretended cure villainies is that the

that catch victims are largely published in religious papers. Another peculiarity is that a large percentage of the quack scoundrels are conspicuous for their religious pretensions, some of them being preachers, while others figure as pious benevolent philanthropists.

Many poor creatures who have become addicted to the alcohol habit and have lost the power of withstanding temptations turn to the drink-cure quacks or institutions in hopes of finding help. The most they receive is treatment that turns them upon the opium instead of the alcohol habit. Mark Twain sent a coachman in whom he was interested to the Oppenheimer treatment, and he was declared cured, but continued to get drunk when opportunity offered. From this experience Mark Twain denounced the institution as a fraud. On the same case Mr. Adams writes: "Therefore, the treatment is based upon misrepresentation and fraud, and the whole concern is an example of high-class, skillfully devised and conducted quackery. The so-called drug cures, such, for instance, as the Richie Painless Cure, St. Paul Association Cure, Tri-Elixiria Harris Institute Cure, Drug Crave Crusade, to name only a few, all contain morphine, and by administering morphine they pretend to cure the morphine habit." The fact of the matter is that the poor sufferers who pay for cures are left in worse condition than ever.

#### Gives Way to Railroad.

An interesting historical memorial will soon disappear as a result of doubling the tracks of the railway from Ulm to Sigmaringen. It is the cliff called Napoleon's rock, on which Napoleon I stood while the troops of General Baron Mack marched past after the surrender of Ulm on October 20, 1805. The exact spot occupied by the Emperor is marked by a pillar bearing the date of this notable event, which began so brilliantly the campaign of Austerlitz. This historic scene of the Ulm garrison's march past is reproduced with great exactness in a picture in the Gallery of Battles in the palace of Versailles. The Napoleon Rock is situated on the slope of the Kleinleberg. The track that is to be doubled runs at its base. The engineers had planned to turn the whole line to the north in order to save the historical memorial, but high authorities thought it better to suppress the obstacle than to get around it. Perhaps other considerations had weight which they might not care to admit. But history cannot be obliterated.—New York Tribune.

# Air Brake Department

CONDUCTED BY J. P. KELLY

## Position of H<sub>5</sub> Brake Valve Handle While Backing Passenger Trains.

At the recent convention of the Traveling Engineers' Association, the above question was propounded by Mr. Leroy Carlton, of the Chicago & North-western Railroad. Considerable discussion followed, which disclosed the fact that there was quite a difference of opinion among the members present as to whether the handle should be carried in running or in driver brake holding position while a passenger train is being backed and the brakes are being operated with a back-up hose and valve.

Our readers will no doubt remember that in the past, this question has been discussed quite thoroughly by air brake men, and the result of all the discussion has shown that the majority favored the running position. Local conditions seemed to warrant some in carrying the handle in lap position; but this position was never much favored for the reason that it closed off the supply of air from the brake pipe, which prevented the operator of the back-up valve from releasing the brakes when he desired without the co-operation of the engineer. Others have advocated carrying the handle in running position, with the added instruction that the engineer move the handle to lap when he felt the brakes applying, but this method had the objection of dividing the responsibility, for properly operating the brake, between the engineer and the operator of the back-up valve.

The running position seems to us to be the proper one in which to carry the handle of the H<sub>5</sub> brake valve when a train is backing and the brakes are being operated from the rear, for the same reasons that have been urged in the past for the G<sub>6</sub> valve, namely, that the main reservoir is always in communication with the brake pipe, providing for a continuous supply of air at feed valve pressure, to the latter, and that the responsibility for the manipulation of the brake is not divided, but rests entirely with the manipulator at the rear.

With the H<sub>5</sub> brake valve, however, there is a choice between running and holding position to carry the handle in while backing, which seems worthy of some consideration. If carried in running position the locomotive brakes will not remain applied in service but will gradually release; if carried in holding position the locomotive brakes will ap-

ply and will remain applied until the engineer releases them. The running position has the objection of not holding the brakes on the locomotive after they are once applied; the driver brake holding position has the objection of requiring the co-operation of the engineer to the extent of releasing the locomotive brakes.

The Westinghouse Air Brake Co. recommend the running position for the H<sub>5</sub> brake valve handle, since the objec-

tion, when backing, close to the driver brake holding position, and thus prevent the locomotive brakes from releasing in service while the back-up valve is being used, and at the same time permit them to release along with the train brakes when the back-up valve is closed.

## The Self-Locking Angle Cock.

No new device in air brake equipment has met with so pleasant a re-

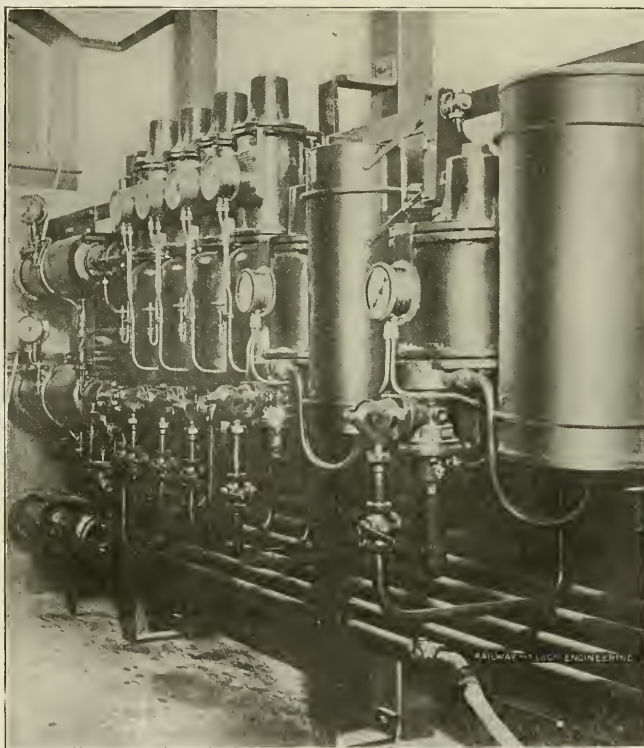

CAR BRAKE EQUIPMENT, SO. PAC. RY. INSTRUCTION ROOM, LOS ANGELES, CAL.

ception cited is of little weight, and this recommendation will, we think, be found perfectly satisfactory, since it gives the tail man complete control of the train both in service and in emergency applications, without, in any way, dividing the responsibility.

It is our opinion that many engineers will, as they grow familiar with the E T equipment, place the H<sub>5</sub> han-

dling position from the railroads as the self-locking angle cock, recently brought out by the Westinghouse Air Brake Co.

This angle cock effectually eliminates the possibility of the accidental closing of the brake pipe, either from flying or swinging objects striking the handle, or from trainmen carelessly stepping on it when going from one car to the other. Although accidents that may

justly be charged to the "closed angle cock" have been very rare, it is, nevertheless, a fact that the angle cock has occasionally closed without the knowledge of the train crew, while the train was in motion to be discovered only after the accident, when looking up the cause. Because of the remote possibility of the present plain angle cock accidentally closing, it has often been charged with the responsibility for accidents, where the brakes failed to stop the train, when the real cause was failure to apply them in time to prevent the trouble.

The self-locking angle cock cannot be charged with accidental closing, and since the locking improvement is all contained in the handle, which can readily be applied to the angle cocks now in service, many railroads are adopting it as standard and are applying it to the cars now in service. All new brake equipments have the self-locking angle cock included in the schedule, so that it is very much in evidence on the new cars now being turned out of the car works, and on the old ones at present in service that are having brakes applied to them.

#### Slippery Rails.

At this season of the year in the early morning hours, the rails are generally covered with frost, and its presence is always accompanied with difficulties in hauling trains, on account of the slipping of the driving wheels and when stopping them with the brakes, on account of the sliding of the wheels, to the extent of seriously flattening them. To

are open, and that they deliver the sand fairly to the top of the rail on both sides.

When needed to make a stop, get the sand under the whole train before commencing to pinch them down very hard. If any of the wheels should commence to slide before sand is dropping, then to begin to sand the rails in the hope of

#### Tunnels Under the Hudson River.

Last month both "tubes" of the Pennsylvania Railroad tunnel under the Hudson river between New York and Weehawken were officially opened. That simply means that there is now subaqueous communication from each side of the river, but trains cannot be run

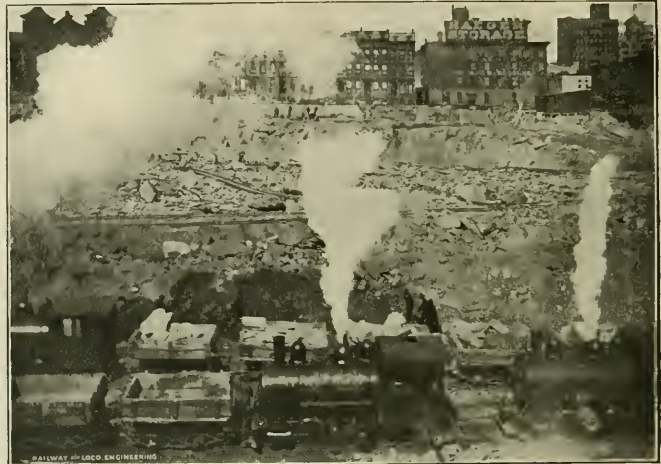

EXCAVATIONS IN NEW YORK CITY FOR PENNSYLVANIA TUNNEL

getting them to revolve would only make a bad matter worse.

On long freight trains, say, from fifty to one hundred cars, if the sand is started well in advance of the initial reduc-

tion for many months yet, as a lining of cement 18 ins. or 2 ft. deep has to be put on and piles have to be driven down under the tunnel down to solid rock. The piling will sustain the heavily lined tubes and carry the weight of the trains which pass through. After this work has been done the interior will be finished and the permanent tracks laid.

The New York end of the tunnel comes up at Thirty-third street and Eleventh avenue, and the New Jersey end will join the extension which is being driven through that low-lying mass of rock known as Bergen Hill. Each tube is about 6,600 ft. long and each will contain one track, on which electric locomotives will haul ordinary railroad trains.

Work in each tube was carried on simultaneously from both ends. Tunnel shields, similar in principle to that referred to in our June issue, page 244, were driven in from both ends. The meeting of the workers in the north tube occurred four weeks earlier than that in the south tube. The shields met in the north tube about 300 ft. beyond the half way point nearer New Jersey, while the shields in the south tube came together about 200 ft. past the center, nearer to Manhattan.

As a triumph of engineering skill, the driving of the Pennsylvania tubes has been unique. Some days before the opening of the tunnels very careful measurements were taken to ascertain the

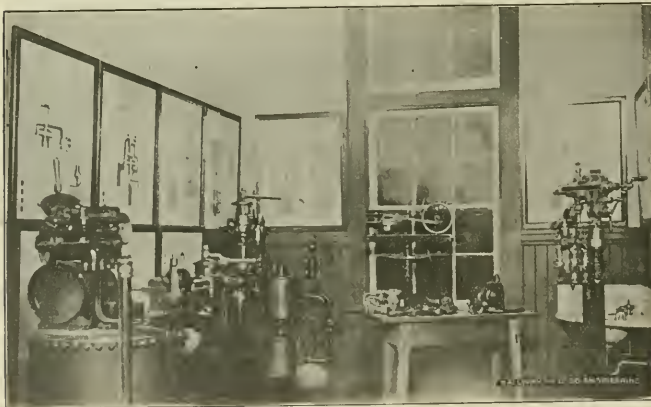

SECTIONAL APPARATUS, SO. PAC. RY. INSTRUCTION ROOM, LOS ANGELES, CAL.

lessen these difficulties sand is used; but unless it is properly applied to the rail, especially when making service stops, more harm than good is bound to result.

It behooves the engineer, therefore, to see that his sanding apparatus is in perfect working order, that he has a liberal supply of grit in the sand box before leaving the terminal, that the sand pipes

tion, it will get under the wheels about as fast as the brakes will apply, and there will be no danger of sliding the wheels. Sand running under a sliding wheel will cut down the tread very fast, the amount for any given distance of sliding, of course, depending on the weight it is carrying and on the hardness of the metal in it.



alignment. When the shields actually came together in the north tube the deviation in direction was found to be only one-sixteenth of an inch, while in the case of the south tube the shields met exactly, with no observable deviation in the lines joining their centers.

The work was done by the O'Rourke Engineering Construction Company, of which Mr. John F. O'Rourke is president. Work was begun in June, 1905, on the north tube, and a month later the south tube was begun. When completed the tubes will have an interior diameter of about 18 ft.; as it is now, the tubes without the concrete lining are about 22 ft. in diameter, and this is the size of the excavation which has to be made by the contractors. The tunnels will in fact be like tubular bridges of circular form carried on piles and buried in the soft mud and sand below the river bed. In order to carry out the work in such material an air pressure of about 35 lbs. to the square inch had to be maintained, that is, the men who worked in the tubes

#### Culm Burner for the D. & H.

The American Locomotive Company have recently built at their Schenectady works six consolidation locomotives for the Delaware & Hudson, which in weight and tractive power greatly exceed any engines of this type in service on that road. They have a total weight in working order of 246,500 lbs. They are, with one exception, the heaviest of the 2-8-0 type ever built by the American Locomotive Company. The engines were designed for slow freight and pushing service and have gone into operation on the Honesdale branch of the Pennsylvania division between Carbondale and Racket Brook. Until the present time, the heaviest consolidations in service on this division were the Class E-3-A, weighing 200,000 lbs., and the advent of these new engines, known on the road as Class E-5, will greatly benefit traffic conditions.

The engine, of which our illustration is a good example, is simple, with cylinders 23x30 ins., driving wheels 57 ins. in

cross-tie and reversing shaft bearing which greatly stiffens the frames. The gear as applied to these particular engines is very simple.

These engines have not been in service long enough to permit of any satisfactory comparison between them and the other 2-8-0 operating on the same division; but, judging from the design, the engine should be a most satisfactory one for the service for which it was intended.

All the wheels are flanged and the spring gear for the two leading pairs of drivers is overhung. In the matter of weight equalization, the pony truck and the two pair of leading drivers are equalized together and the two pair of rear drivers are equalized together.

The boiler is a straight top one with a Wooten fire box and has a total heating surface of 4,045.5 sq. ft., of which 252 sq. ft. is in the fire box, 77 in the tube arches and 3,716 in the boiler tubes. The grate area is 99¾ sq. ft. The ratio of grate area to heating surface is as 1

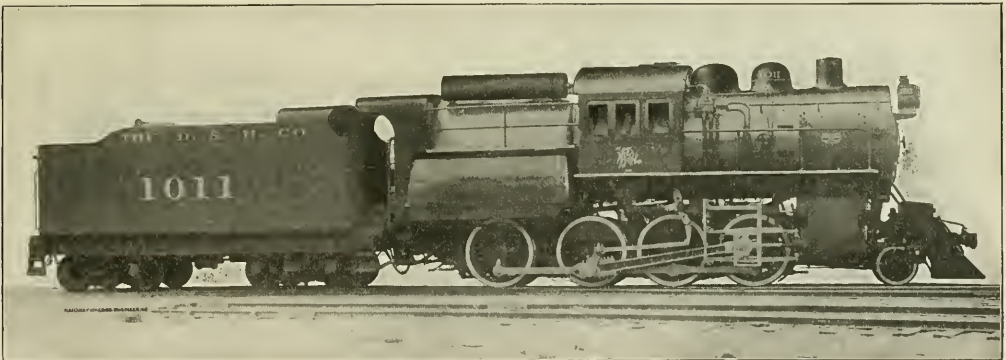

CULM BURNER 2-8-0 FOR THE DELAWARE AND HUDSON

J. H. Manning, Superintendent of Motive Power

American Locomotive Company, Builders

were under a pressure of more than two atmospheres, and according to the statement of Mr. C. M. Jacobs, chief engineer of the Pennsylvania, no lives had been lost in the work of driving the tunnels. As an engineering feat the whole undertaking has been carried out with masterly skill, and all concerned are to be congratulated on the great success which has attended their labors.

The air brake was invented by Westinghouse, 1874; the torpedo by Bushnell, 1777; watch, by Peter Hele, 1477; thermometer, by Drebbel, 1609; telescope, by Lippersheim, 1608; printing, by Gansfleisch, 1438; cotton gin, by Eli Whitney, 1793; microscope, by Jansen, 1590; lithography, by Senefelder, 1798; lightning rods, by Franklin, 1752; gunpowder, by Schwartz, 1320; balloon, by Montgolfier, 1783; barometer, by Torricelli, 1643.

diameter. The tractive power of the machine is 49,690 lbs., which gives a factor of adhesion of 4.38, and while there is a 23 per cent. increase of weight over the E-3-A engines which have been on the road for some time, there is 26 per cent. increase in the tractive power. The engine is equipped with piston valves. A feature in the design is the application of the Walschaerts valve gear. It has come to be very generally conceded that the use of this gear, particularly on engines of great weight, such as the ones of which we write, increases the efficiency of the engine and reduces the cost of maintenance. Placed outside of the frames, this valve gear is accessible for lubrication, inspection and repairs, and this fact tends to reduce roundhouse work in this particular. It has been possible with the Walschaerts gear on these engines to put in a heavy combination

is to 40.6. The boiler has a diameter of 83¾ ins. at the smoke box end and is made in two courses. The steam and water space above the crown sheet is on the average 22½ ins. The roof sheet is horizontal but the crown sheet slopes slightly down at the back. The fire box sheets are flanged at the fire hole door with a considerable bulge or easy curve, which is intended to allow for expansion and contraction.

The weight carried on the drivers is 217,500 lbs. This gives a ratio of weight on drivers to total weight of 88 per cent. The ratio of tractive power to heating surface is 12.3 per cent., and that of total weight to heating surface is 61 per cent. The driving wheel base is 17 ft., the total wheel base of the engine is 25 ft. 11 ins., and that of the engine and tender is 57 ft. 7¾ ins.

The tender frame is made of 15 in.

channels and plates. The tank has a water bottom and contains 7,800 U. S. gallons, and carries 14 tons of coal. Some of the principal dimensions are as follows:

Weight—In working order, engine and tender, 398,900 lbs.

Driving Journals, 10x12 ins.; engine truck journals, diameter, 6½ ins.; length, 12 ins.; tender, 5½x10 ins.

Boiler—Working pressure, 210 lbs.; fuel, fine anthracite coal.

Fire Box—Type, Wootten; length, 126½ ins.; width, 114 ins.; thickness of crown, ¾ in.; tube, 9/16 in.; sides, ¾ in.; back, ¾ in.; all water spaces, 4 ins.

Crown Staying—Radial.

Tubes—Material, iron, 493; diameter, 2 ins.; length, 14 ft. 6 ins.; gauge, No. 11, B. W. G.

Grate—Style, rocking, with water tubes; piston packing; Hunt Spiller gun iron rings.

Valves—Type, piston; travel, 5½ ins.; steam lap, 1 in.; exhaust lap, line and line inside; setting, 3/16 in.; lead, constant.

out, I doubt if the layman could suggest a good remedy.

I am inclined to agree with the "high official" referred to in his statement that "trains do run by caution or green signals every day at sixty miles an hour." This is not necessarily a dangerous proceeding. On a great many roads when passing the distant or caution signal the conditions are such that the engineer can plainly see the next block signal and proceed accordingly. The rule on this point states, "proceed with caution to the home signal." Then there is one rule which used to be printed in large type in the standard code: "In all cases of doubt or uncertainty, the safe course must be taken and no risks run."

There we are, as plain as A B C, but, of course, it is not always obeyed. An-

to make, viz., that there may be times when it is all right to run past a caution signal, at the rate of 60 miles an hour, is, in our opinion, entirely wrong, for the simple reason that it violates a principle. The caution signal speaks with the same clearness that the stop signal does, and the caution signal says by its position or color what is equivalent to the words addressed to the engineer of an on-coming train: "The home signal at the block next ahead is against you, prepare to stop now." The violation of the whole meaning and intention of the caution signal, when deliberately passed at high speeds, is a serious matter, entirely apart from whether the result be disastrous or not, because it allows men to become careless, and in time to think that their judgment is superior to the indication given. It is not a long step from habitually disregarding a caution signal to the looking with contempt on the stop signal itself.

The plain duty of every railroad official is to sharply discipline the man who disregards a signal without reference to whether or not an accident follows the disregard. The safety of travel on American railroads imperatively demands that there be no blowing hot and cold about the block system. Absolute obedience, enforced every time and all the time, year in and year out, is the only possible way to bring our transportation system up to that high level of safety where it undoubtedly should be. We want to see American railway travel not only the cheapest but the safest in the world, and to attain the measure of safety which we all desire, there is only one rule of conduct on the road: implicit obedience to every signal indication.

We have from time to time called attention to the introduction of acetylene for general illumination, searchlights, cooking and other purposes. The Commercial Acetylene Company, of New York, are not only throwing light upon the dark places of the earth, but they are doing it with a degree of energy that is only equaled by the brilliance of the light. The favor with which the lighting of railway cars has been received has been more than duplicated by the recent introduction of the acetylene light into many typical first-class yachts and other sea-going vessels. The company's safety storage system, the absence of odor, the steady brilliance of the light, in all weathers, renders the use of acetylene a delightful change from uncertainty to what Mr. O. F. Ostby, the company's representative, calls the "light that never fails." The company have just issued a new catalogue, finely illustrated, and those interested in this illuminant as applied to water craft, should send for a copy to the company's office at 80 Broadway, New York.

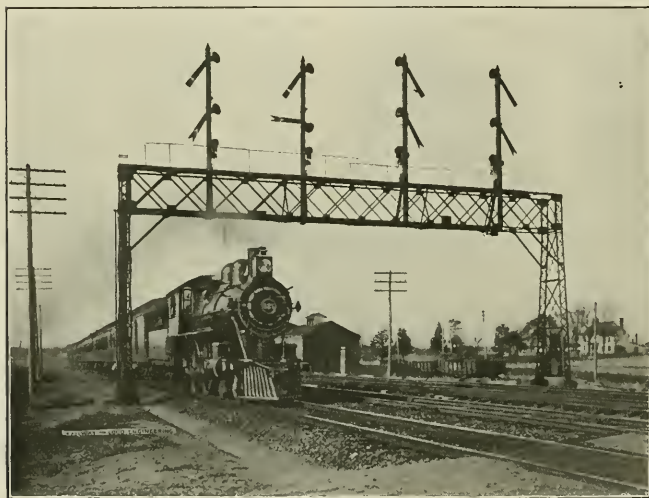

LINE CLEAR FOR THE THROUGH EXPRESS

Wheels—Engine truck, diameter, 30 ins.; kind, Paige cast iron spoke; tender truck, diameter, 33 ins.

### Respecting Signals.

The following letter appeared in the New York Sun of October 6 and was no doubt written in answer to a letter sent to the Sun by Mr. Angus Sinclair, Editor of RAILWAY AND LOCOMOTIVE ENGINEERING. The original letter appears on page 502 of this issue. Its perusal may be interesting to our readers, and it is printed as it appeared. Here is a rejoinder with some of our own observations appended:

To the Editor of the Sun—Sir: I do not see how Angus Sinclair or any other layman is capable of knowing where the responsibility in a railroad accident belongs. The results of the investigations conducted by the road are not made public, with good reason, perhaps. Even if the findings of the "court" were given

other rule that is interesting just at this time is:

"When a train is stopped or delayed, under circumstances in which it may be overtaken by another train, the flagman must go back immediately with stop signals a sufficient distance to insure full protection."

There is a rule for you! Its efficiency depends upon the flagman's judgment as to how far back he must go. They won't go back, and you can't get them to unless there are officials on board. They don't like to get left out in the woods. On roads where block signals are used it is the usual custom for the flagman to stand within ten feet of the rear of his train, for he knows the block should protect his train.

Just as long as there are trains run there will be accidents.

X. RAILROADER.

New York, Oct. 5.

The point which X. Railroader desires

### Walschaerts Valve Gear.

The first meeting of the New York Railroad Club for the season 1906-7 was held at Carnegie Hall last month and was largely attended. The feature of the evening was the presentation of a paper on the above subject by Mr. James Kennedy, Associate Editor of RAILWAY AND LOCOMOTIVE ENGINEERING. Mr. Kennedy contrasted the Stephenson and Walschaerts valve gearing and claimed many advantages for the latter as applied to the largest class of locomotives.

Regarding the Walschaerts valve gear Mr. Kennedy stated that the absolute perfection of mechanism, as in the perfection of art, eludes and ever will elude the seeker after the ideal. The contrivance is not altogether perfect in its movement as no motion ever can be that depends on rotary motion being changed into lineal motion by the use of connecting rods. However limited the path of the crank may be, a certain brief space is lost in the first half of the stroke to

rod is engaged by an intervening union bar which is attached to the crosshead, and the correlation of the short distance between the union bar and the bar driven by the eccentric rod and radial link, and the lower end of the union bar, becomes the determining factor in moving the valve away from the central position to the point desired.

This is not all. The action of the intervening union bar is such that at the opening of the valve the motion is accelerated, and a rapid opening at the end of the stroke of the piston becomes a peculiarity of the valve's motion, in addition to which the opening becomes a fixed quantity unchanged by the variations of valve travel. Adding to this the fact that the intervening radial link oscillates in a much smaller arc than is the case with the Stephenson valve gear, it can readily be seen that the regularity of the movement is at all times under perfect control and the path of the valve can be defined with a degree of exact-

Indirectly, other benefits followed the introduction of the Walschaerts valve gear. The absence of the link motion very much facilitates attention to the driving boxes, and, for the same reason, it has been practicable to introduce strong bracing between the frames in order to lessen what has been one of their greatest sources of expense in locomotive maintenance, namely, frame breakage.

In conclusion, Mr. Gibbs claimed that a gear which is square and remains so is to be preferred to one in which various sources of lost motion combine to render the actual distribution very different from that figured on the drawing board. The effect of the constant lead is not noticeable in the performance. In other words, the advantages of the Walschaerts gear, as they are at present, are purely mechanical. The breakages have been very few and were readily remedied; and if the future history confirms the earlier showing, the belief is

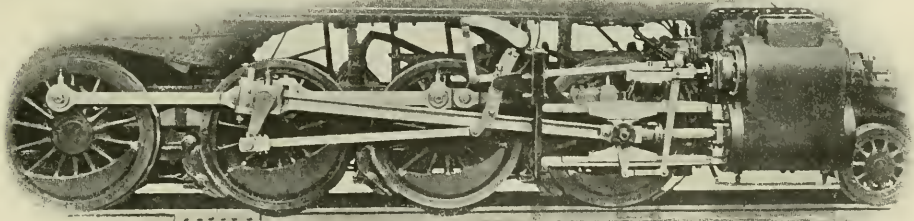

WALSCHAERTS VALVE GEAR APPLIED TO A 2-8-0

which its equivalent is added in the second half. In a reversing engine this variable motion will always be a factor of disturbance in all calculations, but it can be justly said that in the Walschaerts valve gear the difficulty can be rendered of as little effect as can be looked for in any mechanical movement of mere human invention.

The perfect adjustment of the eccentric crank at right angles to the main crank to which it is attached is the primal necessity in the construction of the gearing. It can readily be seen that a connecting rod attached to a crank so fixed would convey a motion to the ordinary sliding valve which, if correct in point of length, would place the valve in the center of the valve seat when the piston would be at the end of the stroke. With the lap and lead necessary for the economic use of steam, it is a simple question of how far the valve should be removed to reach the desired point. The moving of the valve to this point is the distinct and crowning feature of Walschaerts' masterly invention. The valve

ness that leaves little or nothing to be desired.

Mr. A. W. Gibbs, General Superintendent Motive Power of the Pennsylvania, led the discussion in an able and lucid statement of the experiences of the Pennsylvania Company in the use of the Walschaerts gearing, but stated the reason for becoming dissatisfied with the Stephenson link motion was purely mechanical; and had they continued to stick to the older types of locomotives, their attention would probably not have been called to the necessity for a change.

Mr. Gibbs described their early experiences with the new gearing and so favorably had it been received that at the present time there were 352 locomotives equipped on the lines East of Pittsburgh, and on the lines West 55 more, and contrary to all expectations, no protest whatever came from those using the engines when the locomotives with the Walschaerts gearing was introduced, the road people, without exception placing high value on the accessibility of the gear.

that from the transportation side the locomotives with the Walschaerts gear will be very popular, owing to absence of breakdowns on the road.

Mr. C. J. Mellin, Consulting Engineer of the American Locomotive Company, followed, and claimed that the Walschaerts valve gear retained its original condition practically from one shopping to another, making on the average a better utilization of the steam, whereby a slight economy is obtained. The advantage of being removed from the inside of the frames cannot be overestimated, as the frames can thereby be so firmly bolted together that a great saving in maintenance and longer mileage can be obtained by an engine provided with this gear.

Mr. Mellin then proceeded to show a series of graphic illustrations with the aid of lantern slides, exhibiting the methods by which the principal dimensions of the gear can be determined.

Mr. Angus Sinclair followed in an able analytical criticism of the Walschaerts

valve gear, and while admitting its many advantages he claimed that an excellent feature of the Stephenson valve gear had been acknowledged after long abuse to the change of the lead as the link was hooked up. That gave quicker admission and release than when the lead was constant. The consequence was that for slow, heavy work you had an engine with little lead, and for fast running you had one with a great deal of lead. With this Walschaerts you must have a constant running lead. You must have a great deal of lead, and when you have a fixed motion it is too much for slow, heavy work, and not enough for high speed. The consequence is that it must be acknowledged that the Walschaerts motion is not adapted for an engine which has to pull very hard and slowly

we should have no lead; that is, no positive lead, and a small amount of negative lead is a decided advantage in all cases. If a constant lead is so great an advantage, I am surprised that the builders and maintainers of locomotives having the Stephenson valve gear did not adopt it years ago, because the Stephenson gear can, in most cases, be set with a constant lead.

Mr. F. F. Gaines, Mechanical Engineer of the Philadelphia & Reading, also spoke favorably of the Stephenson gearing and expressed himself as believing that much of the troubles alluded to were due to improperly balanced valves, long hooked eccentric blades, and other mechanical defects of that nature, and not due to the valve motion itself, but

the debate and added a short biographical sketch of the life and work of M. Egide Walschaerts, which was warmly appreciated by the members.

#### Observations on Flexible Staybolts.

BY E. E. D. STAFFORD.

The temperatures of furnace heat in locomotive fire boxes are so variable and so intense that great stress is produced in the fire sheets in the process of distension, and this stress has to be borne by both sheet and staybolt. The usual method of staying, in affording the greatest or the least resistance to the force of expansion, is conceded to be directly accountable for the breaking of the ordinary water space stay.

The fire sheet being thin, compensates

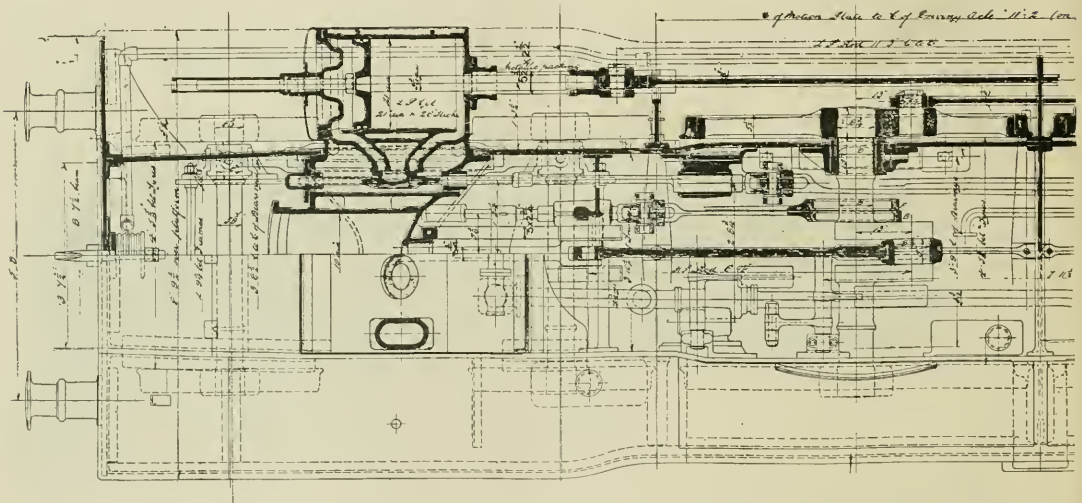

PLAN OF THREE CYLINDER COMPOUND LOCOMOTIVE ON THE

at one time and very fast at another while doing daily service.

Mr. J. White, Mechanical Engineer of the New York Central lines, stated that the author of the paper was in error in attempting to stamp all of the expectations with the mark of fulfilment. Some of the expectations had not been realized. The only positive thing was that it was outside the frames. Sufficient data had not yet been obtained to show its superiority over other systems of valve gearing.

Mr. C. E. Quereau, Superintendent of Electric Equipment of the New York Central, also spoke in favor of the Stephenson gearing. It had served well for many years, he said, and Mr. Sinclair put it very nicely when he said, in effect, that it is impossible to have one constant lead that will give the best steam distribution under varied conditions of service. In full gear I believe

the way it was designed and the way it was carried out.

Mr. Gibbs cleverly rejoined that so far as the Pennsylvania Company had gone, the difficulties anticipated with the Walschaerts gear by Messrs. Sinclair, Whyte and Quereau had not materialized. Any injurious effect of the lead in full gear on these locomotives, as anticipated by Mr. Quereau, should have developed by this time in the freight locomotives, which form the great majority of the locomotives equipped with this motion. These locomotives naturally do a great deal of their work in very heavy dragging service, and so far nothing has been heard from the service to indicate that these locomotives are in any way deficient in tractive power when working slowly, and they also very nicely handle fast freight trains.

Mr. Kennedy very happily concluded

to a great extent in resisting the force of expansion by buckling and bending between the rigid stays, otherwise greater and more serious results would be produced; yet, while the material involved may, in a sense, safeguard, to a certain extent, the life of the fire box, it does not follow that material can or ever will, in the form of a rigid staybolt, provide for the expansion of the fire sheets without finally breaking, or that a fire sheet, when rigidly stayed, can constantly buckle and bend without final rupture and cracking.

Irrespective of what material a staybolt may be made of, and regardless of how careful the construction work may have been done, the whole proposition was one of extreme rigidity, with no provision to compensate for the expansion of fire box.

The continual breaking of staybolts and cracking of fire sheets points to but

one conclusion, and the modifications resorted to in an effort to remedy this condition, show that a locomotive fire box is too rigid.

Flexible staybolts, properly distributed over a sufficient area of fire box sheet, to render plate expansion more in accord with what naturally takes place, removes to a great extent the liability of bending and buckling the fire sheet, which is a serious condition, from the fact that when the fire sheet is distorted by bending and buckling, a separation of the molecular structure is bound to occur, exposing the internal section of the material to disintegration, and leaving it in a state inadequate to cope with the forces due to expansion.

In determining the form of flexible staybolt to use, careful consideration

Means of inspection should be provided on all flexible staybolts, for should the occasion arise, the staybolt proper can be tested for the purpose of detecting breakage without damaging or in any way impairing the future usefulness of the complete bolt.

#### Proposed Railroad Museum.

Progress in the design of American railway equipment has been rapid and significant. This is especially true of motive power equipment. A collection of historic locomotives, disclosing some of the steps which have led to present day development, appeals not only to the students of engineering, but to those who have a scientific interest in the development of material things as well. The value of such a collection will in-

pecially those interested in railway subjects, come from many different parts of the world. It has long given special attention to the teaching of various subjects touching the interests of railways. It has originated and for fifteen years has operated a locomotive testing plant. It has in different ways, and acting in co-operation with various interests, assisted in the development of information concerning the performance of locomotives and other railway equipment. It is still engaged in this process. It has been selected as the official laboratory of the Master Car Builders' Association.

Purdue University receives its support from an endowment and through the operation of national and State laws. Its annual income at this time is approximately a quarter of a million dollars,

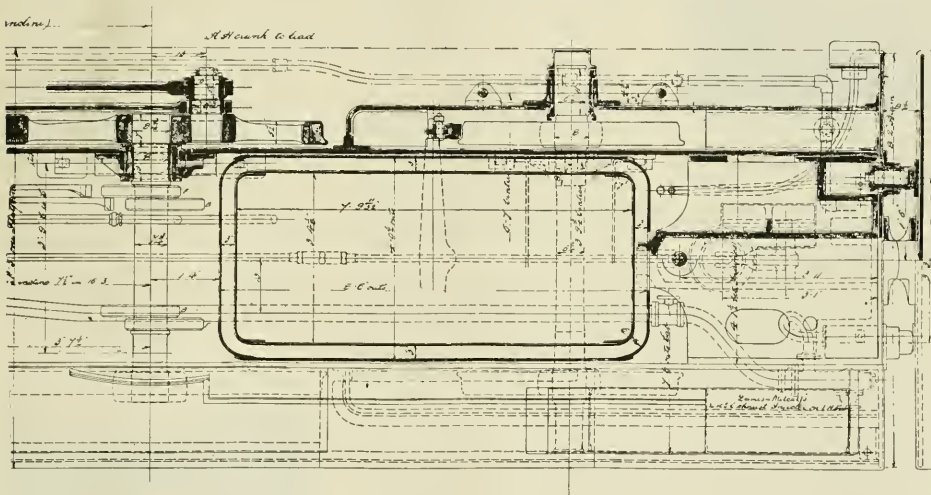

GREAT CENTRAL RAILWAY OF ENGLAND. (See page 504 of this issue)

should be given to all the features relating to the design and construction of the complete bolt, so as to withstand constant service without liability to rupture, and capable of maintaining free movement under all conditions of incrustation. Particular attention should be directed to the principle of design in its mechanical form, to insure by its method and position when applied, the ability to readily and effectually resist stresses both tensile and transverse, and provide for the load due to boiler pressure, and the forces due to expansion.

A clear water space from sheet to sheet is preferable, and all bolts that obstruct the circulation by the protruding of sleeves or plugs, not only offers an opportunity for the lodgment for deposits of lime, but generally leaves the bolt shorter and less liable to perform its functions properly.

crease as time goes on. Its establishment cannot be left to the future; it must in large measure be made and cared for as the development proceeds. As a nucleus for such a collection, there are now two groups of historic locomotives in the country, one of which is at Purdue University. Neither are properly housed. The erection of a suitable building would probably serve to unite them, and its maintenance under proper auspices would be a means to the gradual uplifting of the collection.

Purdue University, at Lafayette, Ind., is not far from the present geographical center of American railway systems. It is within easy communication of all parts of the country. It possesses ample ground upon which to develop such an enterprise. It has 1,500 students in engineering courses, and is recognized as one of the largest engineering institutions in the country. Its students, es-

pecially those interested in railway subjects, come from many different parts of the world. It has long given special attention to the teaching of various subjects touching the interests of railways. It has originated and for fifteen years has operated a locomotive testing plant. It has in different ways, and acting in co-operation with various interests, assisted in the development of information concerning the performance of locomotives and other railway equipment. It is still engaged in this process. It has been selected as the official laboratory of the Master Car Builders' Association.

Purdue University receives its support from an endowment and through the operation of national and State laws. Its annual income at this time is approximately a quarter of a million dollars, which amount will increase as the appraised value of the State of Indiana increases. It is not dependent for its support upon the action of successive legislatures.

While the trustees of the University cannot from their own resources erect a museum building, they will undertake to maintain such a building if once established, and to do all that they can to improve and augment the collection which it is designed to protect. As time goes on, the significance of their part, as compared with the part taken by the donors of the building, must of necessity increase.

The favorable action of one interested in the upbuilding of such a museum, while complete and enduring in itself, would be but the beginning of a process which could not fail to have great significance. As an illustration of this, attention may be called to the fact that

thirty years ago John Purdue gave \$50,000 that an institution which the Legislature was then about to establish, might bear his name. No one at that time regarded the incident as especially significant, but in three decades the institution thus named has so developed that its property interests are now valued at several millions, and its annual income is now double the entire Purdue donation.

A museum once established, could not fail to undergo similar development. The trustees of the University will endeavor in every possible way to aug-



MAKING A FILL

ment the value of such instruction given to students. Anything which may be given will be maintained and gradually developed. Viewing the matter wholly as a business proposition, the opportunity is not without attraction, though this is not the basis upon which the appeal is made. The real basis of the appeal is to be found in the service to the engineers of the future, which would be rendered by such a railroad museum.

#### Setting Flues in Locomotive Boilers.

I have tried many different ways of setting flues in locomotive boilers, and the best method I have found covering all classes of engines, is as follows:

First.—Carefully inspect back flue sheet and see that all scale and sediment is removed from the inside of both flue sheet and flue holes—and that all flue holes are perfectly round. Care should be taken to have the sharp corners removed from inside and outside of flue holes, leaving a good fillet so that no damage can be done to the flue from sharp corners. Then insert copper ferrules in flue holes and expand with a sectional expander, leaving it flush with fire side of flue sheet. Copper ferrules should be a neat fit. I do not believe in stretching coppers, but, if necessary, they should be reannealed, as hammering copper hardens it and reduces its expansion. It should be left as soft as possible. Swedge the flues to a neat fit, and remove all scale from the end of the flues, then apply the flues, leaving  $\frac{1}{8}$  of an inch outside of sheet for bead, or  $1\frac{1}{2}$  the thickness of the flue. This would give you on a No. 11 gauge flue  $\frac{1}{8}$  of an inch, which, I think, is plenty for any bead. After flues have all been clinched,

mandrel them out to copper, so as to admit sectional expander, then drive expander once into each flue, fastening them to the proper length for head. After flues have been fastened in this manner, turn them over with a ball-face hammer or a suitable tool to fit the pneumatic hammer. Then roll all the flues, commencing at the two top corners, next roll the center flues and then roll the remaining bottom flues. Then prosser them in the same order as in rolling them, turning the sectional expander twice in each flue. By so doing, I think the expansion is distributed all over the sheet. Finish flues by beading with the standard tool.

The reason for rolling the flues before the sectional expander is used, is because the flues are rolled tightly back against the flue sheet and the expander only has to do its proper share of the work, i. e., putting the shoulder on the flue inside the flue sheet, and not working on the flue inside of the hole.

Rolling the flues after they are expanded shoves the shoulder away from the sheet and takes most of the shoulder out that the expander has made.

I find that heavy copper ferrules give better results than light ones and would recommend them to be not lighter than 40 lbs., because the heavier the copper, the greater the expansion. I also recommend a long ferrule, which should project through flue sheet at least  $\frac{1}{2}$  in., for the reason that heavy scale or sediment will not adhere to copper, and the further we can keep mud and scale from the flue sheet, the longer we can keep flues from leaking. As soon as the water spaces next to back flue sheet become clogged with scale, your cooling capacity is cut out and the flues begin to leak.—G. G. Nicol, Foreman Boilermaker, C. R. I. & P. Railway, in Ryserson's Monthly.

#### Cast Iron for Cylinders.

The practice of purchasing pig iron conditional on analysis is coming rapidly into favor. It is especially noteworthy that in the case of engine cylinders the quality of the metal is of the greatest consequence and in that particular case analyses and test pieces of the metal should be called for in order to ascertain if the material is the best adapted for the purpose. Locomotive cylinders should possess the elements of hardness and strength in a marked degree, and yet be free from brittleness in order to admit of being readily machined. There is also need of care in cooling the castings in moulding the cylinders. It will be readily observed in reboring cylinders that there are very often two large spaces in the inner edge of the cylinder where the metal is worn slightly deeper than in the rest of the cylin-

der. These are adjoining the thickened walls between the exhaust and inlet ports and are softer, because, on account of the increased thickness, these portions were longer in cooling. The pernicious system of removing castings from the sand before being completely cooled has the effect of hardening the thinner portions of the metal and at the same inducing stresses which may end in fracture.

Sometimes a bushing inserted in the cylinder will improve the wearing qualities. Care must be taken to make proper allowance for shrinkage, as excess of pressure tends to brittleness. Cast steel castings with cast iron bushings have been found to be very reliable with an evenness of wear not to be found in the use of solid castings.

It may be added that the presence of sulphur in an excessive degree is one of the chief evils to be guarded against in the selection of cast iron, while the proper admixture of silicon is also of the utmost importance. A committee of mechanical engineers have recommended the following as the best ratios of parts for metal to be used in locomotive cylinders and valves:

	Per Cent.
Graphite carbon.....	2.75 to 3.25
Silicon .....	1.25 to 1.50
Phosphorus .....	.50 to .80
Combined carbon .....	.50 to .70
Manganese .....	.30 to .60
Sulphur .....	.06 to .10



WAR vs. PEACEFUL COMMERCE

Russian railways are broad gauge, so the emperor has two special trains—the one for all journeys within his own dominions, and the other for European expeditions. This latter train is the one that belonged to the late Emperor Napoleon. It consists of six saloons, all furnished with the utmost luxury, and there are several carriages for suites and servants. Three of these saloons are fitted up as drawing room, library and dining room, and there is a kitchen car attached.

Attempt the end, and never stand to doubt;  
Nothing's so hard but search will find it out.  
—Herrick.

# Of Personal Interest

Mr. J. W. Sanford, master mechanic of the Pennsylvania at Meadows, N. J., has been retired on a pension.

Mr. J. W. Hunter has been appointed division engineer of the Evansville & Terre Haute R. R., at Evansville, Ind.

Mr. C. Montgomery has been appointed assistant master mechanic of the Pere Marquette Ry., at St. Thomas, Ont.

Mr. John J. Bernet, who has been assistant general superintendent on the Big Four, vice Mr. H. A. Worcester, promoted.

Mr. J. McManamy has been appointed road foreman of locomotives on the Pere Marquette, with headquarters at Grand Rapids, Mich.

Mr. G. Thomas has been appointed gang foreman of the Knoxville shops of the Southern Ry., vice Mr. H. A. Kibby, promoted.

Mr. William Carroll has been appointed night foreman of the New York Central roundhouse, at East Buffalo, vice Mr. M. Malican, promoted.

Mr. R. Breese, machine shop foreman of the Pennsylvania Lines, at Fort Wayne, succeeds Mr. Young as assistant master mechanic.

Mr. A. J. Ball has been appointed superintendent of motive power of the Detroit, Toledo & Ironton, with headquarters at Jackson, Mich.

Mr. S. J. Ask has been appointed assistant road foreman of engines on the eastern division of the Lake Shore & Michigan Southern.

Mr. W. L. Calvert has been appointed master mechanic of the Missouri Pacific Ry., at McGehee, Ark., vice Mr. R. G. Long, resigned.

Mr. A. B. Phillips has been appointed master mechanic of the Tonopah & Goldfield Railroad, with headquarters at Tonopah, Nev.

Mr. W. E. Farrell has been appointed general foreman of roundhouse and shops on the Big Four, at Columbus, Ohio, vice Mr. H. E. Malone, transferred.

Mr. H. A. Kibby has been appointed assistant erecting shop foreman of the Knoxville shops of the Southern Ry., vice Mr. H. Wilson, promoted.

Mr. L. Pfaffin has been appointed master mechanic of the Indianapolis Union, with office at Indianapolis, Ind., vice Mr. O. H. Jackson, deceased.

Mr. Frank Malone has been appointed general foreman of the Oregon Short Line, at Pocatello, Idaho, vice Mr. L. A. Richardson, resigned.

Mr. H. Wilson has been appointed erecting shop foreman of the Southern Railway shops, at Knoxville, Tenn., vice Mr. T. H. Williams, promoted.

Mr. R. Griffith has been appointed master mechanic of the Colorado Midland Ry.; with office at Colorado City, Col., vice Mr. W. J. Schlacks, resigned.

Mr. M. Hassett has been appointed general engine dispatcher of the Western division of the New York Central & Hudson River, at Buffalo, N. Y.

Mr. Joseph Walker, of Paducah, has been appointed general foreman of the mechanical department of the Nashville & Evansville division of the Illinois Central.

Mr. J. W. Ruffner has been appointed master mechanic of the St. Louis, Iron Mountain & Southern Ry., at Ferriday, La., vice Mr. J. B. Tennant, resigned.

Mr. M. H. Hovey has been appointed signal engineer of the Yazoo & Mississippi Valley R. R., with office at Chicago, Ill., vice Mr. W. A. D. Short, resigned.

Mr. Walter Johnson, assistant engine house foreman, has been appointed machine shop foreman of the Pennsylvania Lines at Fort Wayne, vice Mr. Breese, promoted.

Mr. George H. Pickert has been appointed master mechanic of the Colorado division of the Union Pacific Ry., at Pullman, Colo., vice Mr. G. Thompson, resigned.

Mr. Milton Davis, assistant master mechanic on the Pennsylvania, at Altoona, has been appointed master mechanic, at Pittsburgh, vice Mr. W. Elmer, transferred.

Mr. W. S. Hanley has been appointed assistant engineer of the Chicago and Indiana divisions of the Chicago & Eastern Illinois R. R., vice Mr. C. B. Randell, resigned.

Mr. C. Banks, engineer of tests of the Great Northern, has been appointed mechanical engineer of the Texas & Pacific Ry., with headquarters at Marshall, Tex.

Mr. C. W. Robinson has been appointed traveling engineer of that portion of the Indianapolis Southern R. R. Co., between Switz City, Ind., and Effingham, Ill.

Mr. J. O. Van Winkle, formerly assistant general manager of the Big Four, has been appointed general manager of the same road, with office at Cincinnati, Ohio.

Mr. J. H. Drennan, of the Santa Fe's car department, at Wichita, has been appointed joint foreman of the Santa Fe-Frisco car department, vice Mr. L. H. Klein, promoted.

Mr. W. A. Whitney has been appointed superintendent of the Rio Grande Junction Railway, with office at Grand Junction, Col., vice Mr. W. G. Choate, resigned.

Mr. Wm. Elmer, formerly master mechanic at Pittsburgh, on the Pennsylvania, has been transferred to Altoona, in the same capacity, vice Mr. Thomas, promoted.

Mr. E. B. Norris, general foreman of the Altoona shops of the Pennsylvania, has been appointed assistant master mechanic at the same point, vice Mr. M. Davis, transferred.

Mr. W. Donald, master mechanic of the Rio Grande Western shops in Salt Lake City, has been appointed to a similar position in the Missouri Pacific shops, at Little Rock, Ark.

Mr. S. C. Smith, formerly general foreman of the Big Four roundhouse and shops, at Springfield, Ohio, has been transferred to Delaware, Ohio, in a similar capacity on the same road.

Mr. P. H. Willaford has been appointed assistant erecting shop foreman in the Knoxville shops of the Southern Ry., vice Mr. E. W. Sweetman, assigned to other duties.

Mr. Howard E. Evans, employed by the Pennsylvania, at Altoona, as car distributor, has been appointed assistant roundhouse foreman of the Monongahela division, at Ormsby.

Mr. E. J. Jenkins, formerly with the Denver & Rio Grande, has been appointed master mechanic of the Rio Grande Western shops, at Salt Lake City, vice Mr. W. Donald, resigned.

Mr. F. C. Lindt, formerly general foreman of the Great Northern, at McCloud, Minn., has been appointed superintendent of shops at that place, succeeding Mr. A. L. Graburn, resigned.

Mr. George Thompson has been appointed superintendent of motive power of the Denver, Northwestern & Pacific Ry., with office at Utah Junction, Colo., vice Mr. A. Struthers, resigned.

Mr. John W. Harris, formerly at West Milton, has been appointed road foreman of engines on the Shamokin division of the Philadelphia & Reading, vice Mr. C. M. Stuart, promoted.

Mr. C. M. Stewart, road foreman of engines of the Philadelphia & Reading Ry., at Tamaqua, Pa., has been ap-

pointed master mechanic at that place, vice Mr. G. S. Allen, retired on a pension.

Mr. R. L. Kleine has been appointed chief car inspector of the Pennsylvania and will be attached to the office of the general superintendent of motive power at Altoona, Pa., vice Mr. J. F. Elder, retired.

Mr. W. E. Woodhouse has been appointed master mechanic for the western division of the Canadian Pacific Railway, with office at Calgary, Alta., vice Mr. J. Cardell, assigned to other duties.

Mr. H. W. Lewis, supervisor of signals, at Easton, Pa., has been appointed signal engineer of the Lehigh Valley R. R., with office at South Bethlehem, Pa., vice Mr. C. C. Rosenberg, resigned.

Mr. H. A. Worcester, formerly general superintendent of the Lake Shore, has been promoted to be assistant general manager of the Cleveland, Cincinnati, Chicago & St. Louis, vice Mr. J. O. Van Winkle, promoted.

Mr. W. Moir, general master mechanic of the Northern Pacific at Tacoma, Wash., has been appointed acting mechanical superintendent, with headquarters at St. Paul, Minn., vice Mr. D. Van Alstyne, resigned.

Mr. J. B. Dorsey, formerly master mechanic of the Denver & Rio Grande, at Leadville, Col., has been appointed master mechanic of the Cincinnati, Hamilton & Dayton Ry., with headquarters at Indianapolis, Ind.

Mr. L. A. Richardson, general foreman of the Oregon Short Line, at Pocatello, Idaho, has been appointed master mechanic of the Chicago, Rock Island & Pacific Ry., at Trenton, Mo., vice Mr. A. C. Adams, resigned.

Mr. W. D. Faucett, assistant engineer, at Savannah, Ga., has been appointed first assistant to the chief engineer of the Seaboard Air Line Ry., with office at Portsmouth, Va. Mr. E. C. Bagwell succeeds Mr. Faucett.

Mr. H. E. Malone, general foreman of roundhouse and shops of the Cleveland, Cincinnati, Chicago & St. Louis, at Columbus, Ohio, has been appointed general foreman of shops at Springfield, Ohio, vice Mr. S. C. Smith.

Mr. D. J. Durrell, assistant engineer of motive power of the Pennsylvania Lines at Columbus, has been transferred to Cincinnati, vice Mr. P. T. Dunn, appointed general foreman of locomotive and car repairs at Cincinnati.

Mr. M. S. Curley has resigned as superintendent of motive power on the Sierra Railway of California, and that position has been abolished. Mr. F. C. Keim has been appointed master

mechanic, with headquarters at Jamestown, Cal.

Mr. Michael Malican has been appointed superintendent of the New York Central roundhouse at East Buffalo. He was formerly night foreman, and has been in the service of the New York Central for 30 years, beginning as a machinist.

Mr. P. T. Dunn, general foreman of locomotive and car repairs at Cincinnati, O., on the Pennsylvania Lines West, has been appointed master mechanic of the Chicago terminal division, with office at Chicago, vice Mr. N. M. Loney, resigned.

Mr. C. D. Young, assistant master mechanic, Northwest system, at Fort Wayne, Ind., has been appointed assistant engineer of motive power, Southwest system, of the Pennsylvania Lines West, with office at Columbus, O., vice Mr. Durrell, transferred.

Mr. John F. Long, formerly gang foreman of the Frisco System, at Monett, Mo., has been appointed division foreman of the St. Louis & San Francisco, at Braumont, Kan. Mr. Long has for some time been a valued correspondent of our paper.

Mr. Charles M. Stuart has been appointed master mechanic of the Shamokin division of the Philadelphia & Reading, at Tamaqua, Pa., vice Mr. G. S. Allen, retired. Mr. Stuart was a former locomotive engineer and has held the position of road foreman of engines on that division for some years. He is a thorough mechanic and at one time was foreman at Mahanoy Plane.

Mr. T. Paxton, superintendent of motive power of the El Paso & Southwestern System, who has heretofore had his office at Douglas, Ariz., has had his headquarters moved to El Paso, Tex. At this new location Mr. Paxton will be in closer touch with the executive officers of the road. He has long been a warm friend of our paper, and the best wishes for his continued success are entertained by the staff of RAILWAY AND LOCOMOTIVE ENGINEERING.

Mr. R. M. Crosby, superintendent of the Northern Pacific shops at South Tacoma, has been promoted to be general master mechanic of the Western division. He takes the place of William Moir, advanced to superintendent of motive power of the system.

Mr. F. W. Malott, who has been general foreman of the South Tacoma shops, has been appointed superintendent of the same shops on the Northern Pacific, vice Mr. R. M. Crosby, promoted.

Mr. J. D. McAlpine, employed in the car department of the Lake Shore and Michigan Southern Railway, has published a handsome pamphlet entitled "The Railroad Man and his Charac-

teristics." The purpose of the work is to encourage the railroad men in the conscientious discharge of their duty by showing that their services are appreciated and their good qualities recognized. Mr. McAlpine has a happy faculty of apt illustration, and a perusal of the work cannot fail to be beneficial in sustaining and cementing the growing kindly feeling between the railroad employer and employee. The work is enhanced by the addition of a reprint of "The Locomotive Chase," a thrilling story of the American Civil War, being an account of the Andrews raiders. A collection of interesting statistics completes the pamphlet.

Mr. George S. Allen, formerly master mechanic of the Shamokin division of the Philadelphia & Reading, has retired from railroad service. Mr. Allen started with the company 52 years ago, and few men were more highly honored by the officials than he. He was born in Tamaqua, September 5, 1836, and at the age of 14 entered the machine shop of J. K. and E. K. Smith as a machinist apprentice. After completing his trade he began his railroad career on the Little Schuylkill Railroad as a machinist. Mr. and Mrs. Allen celebrated their golden wedding last spring when they were presented with a chest of gold tableware in honor of the event by the officials of the Shamokin division. On the completion of his twenty-fifth year as master mechanic he was presented with a gold watch, chain and charm.

Mr. David McNicoll, vice-president of the Canadian Pacific Railway, was recently elected a member of the company's executive board. The board now consists of Sir William Van Horne (chairman), Lord Strathcona, Mr. Richard B. Angus, Mr. E. B. Osler, M.P., Sir Thomas Shaughnessy (president of the C. P. R.), and Mr. McNicoll. In 1883 Mr. McNicoll entered the service of the Canadian Pacific as general passenger agent of the Eastern and Ontario divisions. In 1889 he was appointed general passenger agent for the whole road and the steamship department as well. From this position he rose to that of passenger traffic manager. He was appointed assistant general manager in 1889, and in 1900 was elected second vice-president and general manager. This office Mr. McNicoll held until December, 1903, when he was elected first vice-president of the company, which office he still holds, with the added powers of a member of the executive committee. He is a native of Scotland, having been born at Arbroath in 1852.

Mr. R. M. Wiggin, formerly with the Commonwealth Steel Company, has



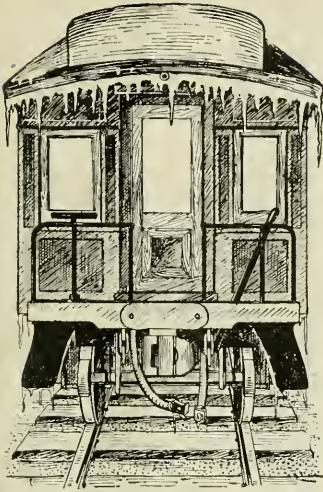

## The Cold Test

With the bleak, cold weather comes more or less imperfect action of the air brakes, and worry and trouble for the engineer as a result. If nothing is done to relieve this condition, you will be bothered all winter, and consequences may be serious.

When the air brake system is lubricated with Dixon's Graphite Air Brake and Triple Valve Grease the brakes respond sensitively to all reductions of pressure. Even in the coldest winter weather this grease will not stiffen and result in emergency action of the brakes when service application is wanted.

Get "proof" sample No. 69-I, and make some trial tests on your engineer's valve and angle cocks.

**JOSEPH DIXON  
CRUCIBLE CO.  
Jersey City, N. J.**

opened an office in the City of Mexico as the representative in that country of Dutilh-Smith, McMillan & Co., of New York and London; National Malleable Castings Co., of Cleveland, O.; American Car & Foundry Co., of New York and St. Louis; International Telegraph Construction Co., of New York; Chicago Railway Equipment Co., of Chicago; Kuhne-Libby Co., of New York, and Skelton & Co., of London. Mr. Wiggin went to Mexico over a year ago to accept the position of assistant to the president and general manager of the Mexican Car and Foundry Company, whose shops are at Hutchison, D. F., on the Mexican Central Railway. Prior to opening the agency office in Mexico he was with the American Steel Foundries at St. Louis for seven or eight years, holding the various positions of draftsman, designer, estimator, traveling engineer and chief engineer. Mr. Wiggin recently stated to a reporter of one of the Mexican papers that although he is an optimist, his business has so far exceeded his expectations as to justify his entering into business for himself. His address is Tiburcio 18, Mexico City, and he will be happy to book orders or hear from his friends in the United States, as the case may be.

### Obituary.

Mr. Philip Ferdinand Kobbe, director and assistant secretary of the Westinghouse Electric & Mfg. Company, died at his summer home at Stockbridge, Mass., September 21, aged 64 years. Mr. Kobbe was one of the pioneers in the electrical business, his efforts always having been devoted to the financial department of the institutions with which he was connected. In 1883 he was elected treasurer of the United States Electric Lighting Company, which position he held until 1890, when the United States Electric Lighting Company was absorbed by the Westinghouse Electric & Mfg. Company, at which time Mr. Kobbe was made treasurer of the latter company. In 1896 he was made vice-president in addition to his duties as treasurer, and in 1902 he became a director of the company.

### King Side Tracked.

The story is told of Louis Philippe, King of the French. He came to the conclusion that a mode of travel which was safe enough for his subjects was good enough for himself, so he ordered a royal train for a trip with his family to his chateau at Bizy. He was unexpectedly, not to say ignominiously, side tracked by a solemn resolution of his council of ministers to the effect that the chief of state ought not to take so hazardous a mode of conveyance.

### Railroad Car Cleaning.

At the last regular meeting of the New York Railroad Club, the paper presented was on the subject of car cleaning. Mr. B. P. Flory, mechanical engineer of the Central Railroad of New Jersey, who read the paper, confined his remarks to the terminal cleaning of railway coachés. Among other things, he said:

"In order to clean cars properly the force should be sufficient to go over them without delay, and should be under the direction of a man who understands the effects of the various cleaners and methods, on the different parts of the car. In order to make the work of the cleaning easier, the cars should be built with as little moulding or carving as possible and yet give a good appearance. This practice is now followed by most roads, and a car with a nearly plain interior, with ornamentation produced by inlaying, looks very elegant and presents a few places for the dust to lie on.

For cleaning the outside body of the car there are numerous materials. Soap and water are used by some roads. Work with this has to be done quickly, especially in warm weather, as part of the soap may dry before it can be wiped off. Dry soap soon gets into the varnish, and every time it gets wet the soap eats into it deeper and deeper and soon spoils the looks of the car. Cold water applied to cars in warm weather and hot water applied to cars in cold weather will deaden the varnish. Oxalic acid is sometimes used when cars are very dirty, and if used properly and followed by oil, it brings out luster and adds life to the varnish. The car, however, should be washed quickly with water after the oxalic acid is put on and before the oil is applied. Oil emulsion is probably the best thing for cleaning the car if applied at proper intervals. It is not necessary to apply this every trip. The car can be washed or rubbed off dry, but oil emulsion should be used about every two months. This, if followed, will keep the varnish in good shape between shoppings. For trucks, wiping with dry waste or with waste with a little oil on it, depending on the condition, is all that is usually necessary. A corn broom, with a little oil on it, is also very good if the trucks are very dirty.

The Central Railroad of New Jersey has installed, at its terminal at Jersey City, a vacuum plant for cleaning both the cars and the station. The plant has been in operation now over two years, and was installed at a cost of approximately \$18,000. The plant consists of two steam driven double acting pumps with vacuum cylinder 20 ins. in diam-

eter and 12 in. stroke. These pumps are 20 h.p. each. The pumps are arranged to operate together or independently, and have 5 in. suction connections to the separators. From the separators one header extends west 2,400 ft., being reduced proportionally from 5 ins. to 4 ins., to 3 ins., with 2 in. lateral lines which run at intervals of every 60 ft., or about a car length, distributing outlets to the coach cleaning yards, having ten tracks.

The operation of the plant is as follows: When the pumps are put in operation, the air is immediately exhausted from the separators and the pipe lines. With no outlets open the vacuum gauge will show about 29 ins., and as the outlets are opened the vacuum will drop according to the number opened. The dust and refuse taken from the car is drawn through the pipe lines to the dry separator and en-

air are large, but upon striking the disc they are broken up into very small bubbles, which creates a foam or fountain which washes out the partially dust-laden air. The hood deflects the air and water against the side of the casing so that there is no water carried over to the pump. The air is practically cleansed before going to the vacuum cylinder and is then exhausted to the atmosphere. When the machine is shut down the dry separator is opened and the dust drops out and is thrown into the ashpit under the grates. The valve connection with the bottom of the wet separator is also opened and the muddy water flows into the sewer. The amount of dust taken out from the dry separator averages about one bushel and a half per day.

The following is the number of cars cleaned per month with the vacuum system on the C. R. R. of N. J.: 270



HAPPY PARTY ON THE LAKE OF BAYS 32-IN. GAUGE RAILWAY

ters on a centrifugal line. Within this separator there is an inner cylinder projecting nearly half way to the center of the separator. The dust takes a centrifugal movement downward around the annular space between the inner cylinder and outer casing, and fully ninety per cent. is deposited at the bottom of the separator. The lighter particles of dust are drawn up through the inner casings by slow suction as the velocity of the air has been changed, the inlet pipe being 5 ins., and the inner cylinder through which the suction must pass is 24 ins. diameter. The light dust then passes into a second separator, which is partly filled with water. The water covers a brass disc which is perforated by several thousand  $\frac{1}{16}$  in. holes. Just above this disc a hood is placed, leaving an annular space between it and the casing for the passage of air, when the air enters underneath the disc which is covered with water. The bubbles of

Pullman sleepers, 510 Pullman chair cars, 272 60-ft. coaches, 92 50-ft. coaches, 18 combination cars (having plush seats), 31 café cars, 62 dining cars, 78 club cars, 13 private cars. This makes a total of 1,346 cars cleaned per month. The cleaning of the Pullman cars is done by a force of nine men who have nothing to do with the cleaning of the other cars."

There is a little booklet on the subject of Air Brake Lubrication which is worth taking a look at, especially as it is free for the asking from the Joseph Dixon Crucible Company, of Jersey City, N. J. In it the use of Dixon's air brake and triple valve grease is spoken of. This grease contains the Ticonderoga graphite for which the Dixon Company are famous. Directions for the use of this grease in triple valves, brake valves and brake cylinders are given. Air pump lubrication is taken up and the use of Dixon's special Graphite, No. 635.

# "J. M."

## RAILROAD SUPPLIES

### OUR NEW CATALOG

Catalogue No. 250 should be in the hands of every Manager, Purchasing Agent, Superintendent, Master Mechanic and Shop Foreman. It contains a complete line of "J.-M." Asbestos and Magnesia Materials which have been adopted by the leading railroad interests throughout the country as standard.

WRITE NEAREST BRANCH  
FOR COPY TO-DAY

Smoke Jacks  
"Transite" Fireproof Lumber  
Asbestos and Magnesia Locomotive Lagging  
"Vulcabeston" Pump Packing  
"Vulcabeston" Gaskets  
"Vulcabeston" Rope Packing  
Train Pipe Covering  
"Kearsarge" Gaskets  
All grades of Asbestos and Magnesia Pipe Covering  
Hair Felt  
"Keystone" Hair Insulator  
Asbestos Cements  
"Retort" Cements  
"Canadax" Wick Packings  
High Pressure Asbestos Packing  
Asbestos Roofing  
Portland Sectional Conduit

### H. W. JOHNS-MANVILLE CO.

Manufacturers of Asbestos and Magnesia Products, Asbestos Roofings, Packings, Electrical Insulating Materials, "Noark" Fuse Devices, Electric Railway Supplies, etc.

NEW YORK ST. LOUIS MINNEAPOLIS  
MILWAUKEE PITTSBURG DALLAS  
CHICAGO CLEVELAND SAN FRANCISCO  
BOSTON NEWORLEANS LOS ANGELES  
PHILADELPHIA KANSAS CITY SEATTLE  
LONDON

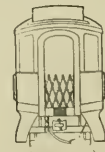

## The Best and Cheapest Books for Railroad Men

### AIR BRAKE CATECHISM

Price, \$2<sup>00</sup>

By Robert H. Blackall. 90th Edition. Contains 1500 Questions and their Answers on the Westinghouse Air Brake, which are strictly up-to-date. Includes two large Westinghouse Air Brake Educational Charts printed in colors. Gives the necessary information to enable a railroad man to pass a thoroughly satisfactory examination on the subject of Air Brakes. The author's many years' experience as Air Brake Inspector and Instructor enables him to know at once how to treat the subject in a plain, practical manner. Endorsed and used by Air Brake Instructors and Examiners on nearly every railroad in the United States. The standard and only complete work on the subject. 313 pages.

### LOCOMOTIVE BREAKDOWNS AND THEIR REMEDIES

Price, \$1<sup>50</sup>

By Geo. L. Fowler. Just issued. Tells how and what to do in case of an accident or breakdown on the road; includes special chapters on Compound Locomotives. Better procure a copy, as it contains 800 Questions and their Answers on Accidents and Breakdowns.

### LOCOMOTIVE CATECHISM

Price, \$2<sup>00</sup>

By Robert Grimshaw. 23d Edition. Is right up-to-date and contains twelve large Folding Plates and 1000 Questions and Answers on How to Run a Locomotive. The Standard Book on the subject, being written in plain language and free from mathematical formulae and complex problems.

### NEW YORK AIR BRAKE CATECHISM

Price, \$1<sup>00</sup>

By Robert H. Blackall. The only complete treatise on the New York Air Brake and Air Signaling Apparatus, giving a detailed description of all the parts, their operation, troubles, and the methods of locating and remedying the same. 250 pages.

### COMBUSTION OF COAL AND THE PREVENTION OF SMOKE

Price, \$1<sup>50</sup>

By Wm. M. Barr. Contains over 800 Questions and their Answers on the Science of Steam Making.

### AIR BRAKE CHARTS 50 c.

Showing the Westinghouse Equipment in ten colors, including freight and passenger engine. Every railroad man should possess these charts at this low price.

A Special Circular of any of these books sent on request. Any of these books sent prepaid on receipt of price.

Agents Wanted at Every Terminal. Write for our special terms. You can make equal to a month's pay selling our books on the side

The Norman W. Henley Pub. Co.

132 Nassau Street, New York, U. S. A.

is explained, and also the benefits of graphite when used in an air pump. Write direct to the company for the booklet. If you are interested it will be a handy vest pocket companion. A sample of the Special 635 grease sufficient for a test is sent free on application, so you can have a sample and the little book easily enough if you care to ask.

### Rack Rail Engine for Pike's Peak.

The Baldwin Locomotive Works recently built for the Manitou and Pike's Peak Railway a rack locomotive possessing several interesting features. The maximum grade on the road is 25 per cent. and the "Abt System" of rack rail is used. In many respects the new locomotive is similar to these previously built, the principal differences being the use of three driving pinions instead of two, and the employment of oil as fuel instead of hard coal.

The boiler is set so that its axis is horizontal on a 16 per cent. grade, the

which are placed on top of the boxes.

The water supply is carried in side tanks, which are supported in brackets bolted to the boiler shell. The oil tanks are placed right and left under the cab floor. The oil is fed through a heater, located at the left side of the engine under the ash pan. The heater consists of an oil pipe 1¼ ins. in diameter, which is placed inside a 3-in. pipe about 4 ft. in length. The annular space between the pipes is filled with steam and the outside pipe is lagged with asbestos covering. The burner which is of a type used by the Southern Pacific Co., is placed under the mud ring in the front end of the fire box. Air is admitted through a hinged damper in the back of the ash pan.

The engine is equipped with steam, hand and water brakes. The steam and hand brakes are of the band type, operating on the first and second driving axles respectively. An auxiliary steam cylinder is also provided for operating the hand brake, if desired. The Le

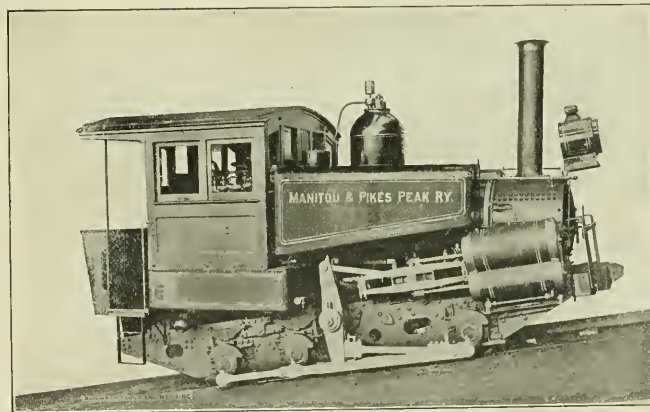

BALDWIN RACK RAIL COMPOUND ON THE M. & P. P. RY.

cylinders being placed on an inclination of 4 in 25. The Vaucrain system of compounding is used, and the wheels are driven through rocking levers having fulcrums bolted to the engine frames. The valve motion is of the "Good" type, with the eccentrics on the leading axle. The motion is indirect, the rocker shafts being placed behind the links and between the engine frames. A screw reverse mechanism is used.

The main frames are of steel plates ¾-in. thick, with cast steel pedestals bolted to them. They are braced in front by top rails, which are bolted to the cylinder castings. The second and third pairs of driving-wheels are equalized together, leaf springs being placed over the driving-boxes. The weight is transferred to the front pair of wheels through rubber springs.

Chatelier water brake is operated by a valve placed on a level with the lowest gauge cock. The exhaust nozzle is fitted with a shut-off valve operated from the cab, to prevent drawing in air from the smoke box when the engine is reversed.

The tractive power of this engine is 25,284 pounds and a few of the leading dimensions are as follows:

Gauge—4 ft. 8½ ins.

Cylinders—10 ins. and 15x24 ins.

Valve—Balanced piston.

Boiler—Type, straight; diameter, 44 ins.; thickness of sheets, 7/16 in.; working pressure, 210 lbs.; fuel, oil; staying, radial.

Fire Box—Length, 48 ins.; width, 50½ ins.; depth, front, 46¼ ins.; back, 40½ ins.; thickness of sheets, sides, 5/16 in.; back, 5/16 in.; crown, ¾ in.; tube, 7/16 in.; water space, front, 3¼ ins.; sides, 2¼ ins.; back, 2¼ ins.

Tubes—Material, steel; wire gauge No. 13; number 126; diameter, 1¼ ins.; length, 7 ft. 11 15/16 ins.

Heating Surface—Fire box, 58.3 sq. ft.; tubes, 546.7 sq. ft. total, 605 sq. ft.; grate area, 19.7 sq. ft.  
 Driving Wheels—Diameter, 22 468/1000 ins. on pitch line; journals, 6x6 ins.  
 Wheel Base—Driving, 10 ft. 3 59/64 ins.  
 Weight—On driving wheels, 60,000 lbs., estimated.  
 Tank—Capacity, water, 600 gals.; oil, 325 gals.  
 Service—Passenger.

The Chicago Pneumatic Tool Company report having received orders from the Chicago, Burlington & Quincy Railroad for 114 Boyer Speed Recorders, to be applied to the new equipment now being received by that road. The Boyer Speed Recorder will register on a dial, wherever it may be placed, either on a locomotive or in private cars. It will register during the run, all stops, total number of miles run, either while the train is running forward or backward. This information is accurately recorded on tape, which can be removed from the recorder when required, for inspection, and filed for future reference. A large number of these recorders are in use on various railroads throughout the United States and a large number have been installed on railroads in foreign countries.

**Cutterhead Brace.**

The Pennsylvania have an arrangement for planing the shell fit of driving boxes at their Columbus, Ohio, shop which has increased the output by about 34 per cent. There is nothing par-

and the tool is held stiffly up to its work and makes a long sweep through a goodly string of boxes as the planer table runs under it.

**Van for Motor Cars.**

To accommodate the general traffic in motor cars, and particularly in connection with the productions of the many car factories springing up throughout their system, the Caledonian Railway have built a number of commodious six-wheel vans for the exclusive transit of these vehicles. These vans are practically special box cars, as we would call them, for although they can be used for the carriage of other freight, they are primarily intended for the transportation of automobiles, and the vans are intended to be handled in passenger trains.

The body framing is of teak, paneled in mahogany. There are two double folding doors on either side, each giving a clear opening of 4 ft. 2 1/2 ins., with large sliding windows which give the interior plenty of light. The waist panels on the doors are of slate, so that address or destination or other information may be written or pasted on the panels and can be easily washed off when required. Each side door is fitted with a slip bolt and carriage standard lock. The center panel at either end on both sides is louvered, and lined inside with perforated zinc. The roof is of galvanized steel plate 1/8 in. thick, supported

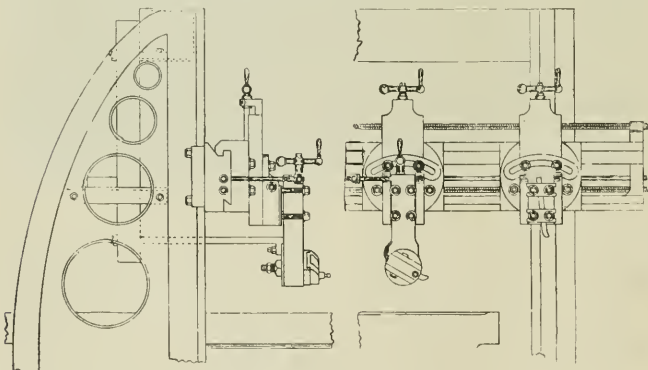

CUTTER HEAD BRACE IN PLANER, FOR DRIVING BOXES

ticular in the arrangement of the head for planing the shell fit of driving boxes except the brace arrangement which prevents the overhang of the head from bending the cross rail of the planer. The general plan of this arrangement is shown in our illustration. There is no particular novelty in the arrangement of the cutterhead which has been in use for a number of years. It was never an entire success, however, until the brace was applied. As it is now, the machine is efficient.

by light steel roof bars of channel and T-sections.

In order to get automobiles in or out, there are two folding end doors, ve-boarded and hung from the corner pillars by wrought iron hinge straps, three to each door, the center hinge straps having a stud and cotter fastening. There is also a slip bolt fastening inside. The doors give openings the full width and height of the van, which is 7 ft. 4 3/4 ins. by 8 ft. 8 1/2 ins. to the top of the arched roof. There are four-wheel

## Q & C= Priest Snow Flanger



Order now for FALL and WINTER deliveries. Will keep your tracks clear, avoiding LARGE PLOWS and EXTRA CREWS.

**Quincy, Manchester, Sargent Co.**  
CHICAGO NEW YORK

# SKAT

is a soft soap sold in a neat lithographed can. When you wash up with SKAT, it gets into the crannies and "hard to reach" corners of your hands and the results are surprising. That's where the dirt lurks and hard soaps won't go. That's why SKAT is so popular. SKAT is made of the best materials, is absolutely pure and guaranteed to give you perfect satisfaction. You'll use it every day and like it more each time.

We can tell you where to buy SKAT, or better still show you how to sell it. If SKAT is not for sale in your locality, let us give you the selling right. Drop us a postal and get a free sample.

**SKAT MFG. COMPANY**  
Hartford Conn.

A Practically Perfect Portable Pneumatic

# PUNCH

Stop moving your heavy work to the machine. One Man brings this tool to the work and punches it besides.

**SAVES  
TIME  
LABOR  
SPACE**



Leading concerns in all parts of the country use this Punch.

**Punch Size 8**  
 Built in 5 Standard Sizes.  
 Special machines built to order.  
 Write for Catalogue C.

**F. F. SLOCOMB & CO., Builders**  
WILMINGTON, DEL.

# GOLD Car Heating and Lighting Co.

Manufacturers of

**ELECTRIC,  
STEAM AND  
HOT WATER  
APPARATUS  
FOR RAILWAY CARS**

**EDISON  
STORAGE  
BATTERY  
FOR RAILWAY CAR  
LIGHTING**

**Largest Manufacturers in the World  
of Car Heating Apparatus**

Catalogues and Circulars  
cheerfully furnished

**Main Office, Whitehall Bldg.  
17 BATTERY PLACE  
NEW YORK**

bars stretching across the vehicle sliding on angle bar brackets, having holes 2 in. pitch for adjusting purposes, giving accommodation for 2 ordinary sized motor cars. There are also notched bars along the sides having a shackle and strap attachment for more securely fixing the load.

Two steel plates 10 ins. by  $\frac{3}{4}$  in. thick run the full length of floor inside on which the wheels of vehicles rest. The vans are fitted with dual brake, and have "through" pipe connections for steam heating, as well as "either-side" hand brake. The tare is 12 tons 19 cwt. Load equals 6 tons.

The following are some of the dimensions: The cars are 30 ft. over body; breadth, 8 ft.  $\frac{3}{4}$  in.; height at center, 8 ft. 10 ins.; and at side cornice, 7 ft.; height from rail at center, 12 ft.  $9\frac{1}{2}$  ins., and at side cornice, 11 ft. The under-

## High Art.

We recently read of a rich man who bought a very beautiful painting in which a partly disabled but very picturesque ship was being towed away from a lee shore by a tugboat. The fury of winds and waves was strikingly depicted, and the smoke from the tug blended harmoniously with the general color scheme of the picture.

The rich man, however, desired some expert as well as artistic criticism of his purchase, so he invited an old sea captain to come and look at it. The captain looked at it for some time, but said nothing about the rolling breakers or the evident fury of the gale or even about the harmonious smoke of the tug. When urged to speak, the captain, strangely enough, altogether ignored the work of the artist and did not even

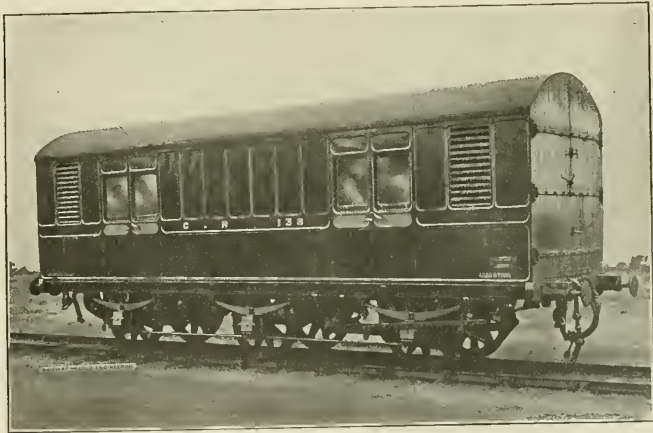

CALEDONIAN RY. VAN FOR THE CARRIAGE OF AUTOMOBILES

frame is 30 ft. long, giving 33 ft. 8 ins. over the buffers. The sole bars and cross members of the underframe are of steel channels, the longitudinal and diagonals being of oak, secured by angle bar and plate knees. The wheels are 45 ins. diameter and 9 ft. between centers, giving a total wheel base of 18 ft.

The vans have been built at the company's St. Rollox workshops to the designs and under the supervision of Mr. J. F. McIntosh, locomotive superintendent.

## Silver Railway Passes.

Sir Thomas Shaughnessy, president of the Canadian Pacific, and Mr. C. M. Hays, president of the Grand Trunk, have both been made the recipients of complimentary passes on the Erie Railroad. The passes are made of solid silver. These rather singular passes are each in the form of a locket, and were sent with the compliments of President Underwood, of that line.

appear to hold him responsible. He said: "I know what ails those fellows on board, who are hoisting a sail. With the wind in that quarter it will act dead against the tug. The crew are drunk; that's what is the matter with them."

This reminds us that before now we have seen a picture of an engine drifting at high speed, where the smoke from the stack issued as a flat ribbon and coiled itself down on the cab, while steam came out fiercely from both cylinder cocks at the same time, showing that the throttle and the piston valves all leaked dangerously, and not only did the injector delivery pipe terminate in the movable end of the rocker, but steam blew out of the edge of the solid guide yoke, and, like the smoke of the tug, blended harmoniously with the color scheme of the picture. This may be high art, but the captain ought to take a look at it.

### Cylinder Patched.

A very satisfactory piece of repair work was recently done by the use of one of the Smooth-On Company's products. A cracked cylinder was made

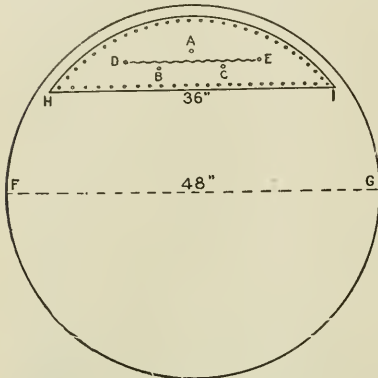

BROKEN CYLINDER PATCHED

serviceable by a practical engineer, who went about it in this way:

While the cylinder was hot and a partial vacuum thereby created in it, Smooth-On Elastic Cement was painted over the crack. The vacuum caused the cement to draw in, and this operation was repeated until the crack would take up no more cement. Holes were then drilled and tapped at the end of the crack, and bolts put in to prevent a further extension of the crack. A patch was cut, as shown in our illustration, and the crack was then painted with Smooth-On and the patch laid in position. Then it was carefully removed.

The outline of the crack was shown on the under side of the patch by the Smooth-On sticking to it. The patch was then dished along the line of the imprint to make a recess to hold sufficient cement. The plate was then warmed and a compound composed of Smooth-On Iron Cement No. 1 and Smooth-On Elastic Cement, mixed half and half, applied to the warm plate with a small trowel, making a thin, even coating. Then the patch was laid in position. The three center bolts nearest the crack were brought up taut. Then the outside bolts were brought up tight, and lastly, the three center bolts were brought up as tight as possible, which forced the cement into the crack. Then steam was turned on and the crack was found to be tight.

The Kennicott Water Softener Company, of Chicago, inform us that they have received through their London office an order from the Eckstein Group of the Rand Mines, Limited, Johannesburg, South Africa, for seven Kennicott Water Softeners.

### Prolonged Effort Not Valuable.

When James J. Hill talks of farming he talks as a railroad expert. He has extensively cultivated his agricultural talent in order to make freight for his railroad, and with the aid of his model farm near St. Paul he has taught the farmers along the Great Northern what they can best grow for their own profit, for by doing so they profit the road also. "Do you raise black Essex pigs, Mr. Hill?" asked the Governor of Minnesota. "Yes." The Congressman from Minnesota, who did not know as much about pigs as he thought he did, pricked up his ears. "Well," said the Governor, "March is a critical time in a young pig's life, Mr. Hill." Mr. Hill assented. "What do you feed him?" "Green fodder." "Dry or wet?" "Dry." "There's where you make a mistake, Mr. Hill," triumphantly exclaimed the Congressman; "it takes a pig three times as long to eat dry fodder as wet."

"And how much do you reckon the pig's time to be worth?" said Mr. Hill, thus closing the conversation.—Harper's Weekly.

### Great Men.

Confucius, the Chinese philosopher, said that great men were great simply because other men were upon their knees. The way to make great men look like common people was for the common people to stand up. The philosopher was right. And nowhere is this more true than among railroad men. Young men beginning railroad work are overawed by the superiority of their elders. The young men should stand up and instruct themselves in the mysteries of their calling.

Right here, RAILWAY AND LOCOMOTIVE ENGINEERING supplies the necessary adjunct. Its pages are filled with the expressions of the best thoughts of the leading railroad men of our time. It has met the universal approval of the leading railway men throughout the world. The price, \$2.00 a year, places it within the reach of every railroad employee.

"Twentieth Century Locomotives," Augus Sinclair Co., deals comprehensively with the design, construction, repairing and operating locomotives and railway machinery. First principles are explained. Steam and motive power is dealt with; workshop operations described, valve motion, care and management of locomotive boilers, operating locomotives, road repairs to engines, blows, pounds in simple and compound engines; how to calculate power, train resistance, resistances on grades etc.

## Homestead Valves

Straightway, Three-way and Four-way, and

## Homestead Locking Cocks

Are Famous the World Over

They cost more, but are worth very much more than other makes. You try them and see.

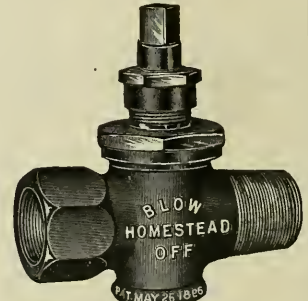

Brass, 1 1/4 in., \$6.00 net

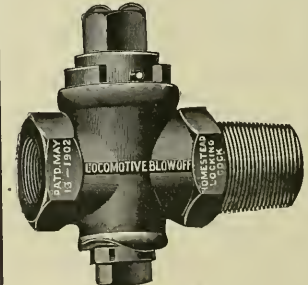

Iron Body, Brass Plug, 1 1/4 in., \$4.00 net

Homestead Valve Mfg. Co.

WORKS, PITTSBURG, PA.

## American Locomotive Sander Company

13th & Willow Sts., Philadelphia, Pa.

Proprietors and Manufacturers

LEACH, SHERBURNE, DEAN, HOUSTON, "SHE" and CERRIS SANDERS

THE ROBERT W. HUNT & CO.

Bureau of Inspection, Tests and Consultation, 1137 THE ROOKERY, CHICAGO, 96 Broadway, New York. Park Building, Pittsburgh.

31 Norfolk House, London, Eng.  
Inspection of Steel Rails, Splice Bars, Railroad Cars, Wheels, Axles, etc. CHEMICAL LABORATORY—Analysis of Ores, Iron, Steel, Oils, Water, etc. PHYSICAL LABORATORY—Test of Metals, Drop and Pulling Test of Couplers, Draw Bars, etc. Efficiency Tests of Boilers, Engines and Locomotives.

## Locomotive Blow-Off Plug Valves

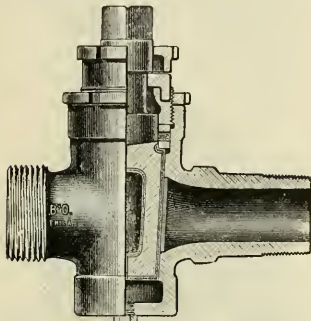

Fig. 9.  
All Brass, extra heavy, with Cased Plug For 250 lbs. pressure. Made with Draining Plug to prevent freezing.

## Locomotive Gauge Cocks

For High Pressure

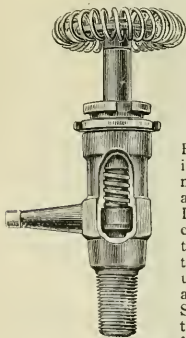

Fig. 23, with Wheel.

Bordo Self-Grinding Gauge Cocks, made with renewable Hard Bronze Disc. Opened and closed with a quarter turn. Guaranteed Steam tight under the most exacting conditions. Shanks Threaded to specifications for Locomotives.

## Swing-Joints and Pipe Attachment

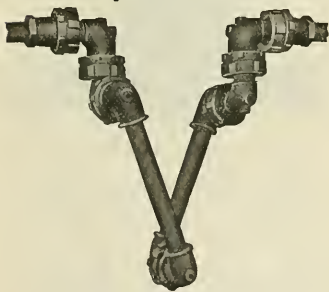

Fig. 33.

May be applied between Locomotive and Tender. These Swing-Joints are suitable for Steam, Gas, Air, Water or Oil.

Complete Booklet on Application

**L. J. BORDO CO.**  
PHILADELPHIA, PA.

Shop tools explained. Shop recipes, definitions of technical terms, tables, etc. Descriptions and dimensions of the various types of standard locomotives. The book is well and clearly illustrated and is thoroughly up to date in all particulars, fully indexed. Price, \$3.00.

"Locomotive Engine Running and Management," by Angus Sinclair, is an old and universal favorite. A well-known general manager remarked in a meeting of railroad men lately, "I attribute much of my success in life to the inspiration of that book. It was my pocket companion for years." Price, \$2.00.

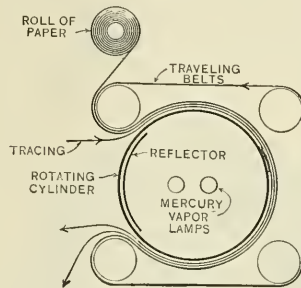

CROSS SECTION OF BLUE PRINT MACHINE

"Practical Shop Talks." Colvin. This is a very helpful book, combining instruction with amusement. It is a particularly useful book to the young mechanic. It has a stimulating effect in inducing him to study his business. We sell it for 50 cents.

"Examination Questions for Promotion." Thompson. This book is used by many master mechanics and traveling engineers in the examination of firemen for promotion and of engineers likely to be hired. It contains in small compass a large amount of information about the locomotive. Convenient pocket size. We cordially recommend this book. It sells for 75 cents.

The 1904 Air Brake Catechism. Conger. Convenient size, 202 pages, well illustrated. Up to date information concerning the whole air brake problem, in question and answer form. Instructs on the operation of the Westinghouse and the New York Air Brakes, and has a list of examination questions for enginemen and trainmen. Bound only in cloth. Price, \$1.00.

"Compound Locomotives." Colvin. This book instructs a man so that he will understand the construction and operation of a compound locomotive as well as he now understands a simple engine. Tells all about running, break-downs and repairs. Convenient pocket size, bound in leather, \$1.00.

"Catechism of the Steam Plant." Hemenway. Contains information that will enable a man to take out a license

to run a stationary engine. Tells about boilers, heating surface, horse power, condensers, feed water heaters, air pumps, engines, strength of boilers, testing boiler performances, etc., etc. This is only a partial list of its contents. It is in the question and answer style. 128 pages. Pocket size, 50 cents.

"Care and Management of Locomotive Boilers." Raps. This is a book that ought to be in the hands of every person who is in any way interested in keeping boilers in safe working order. Written by a foreman boilermaker. Also contains several chapters on oil burning locomotives. Price, 50 cents.

"Locomotive Link Motion." Halsey. Any person who gives a little study to this book ceases to find link motion a puzzle. Explains about valves and valve motion in plain language. Price, \$1.00.

## Blue Print Machine.

The Revolute Blue Print Machine, as shown in our illustrations, consists of a rotating glass cylinder which lies in a series of narrow belts, and within which cylinder are placed two mercury vapor electric lamps. The roll of paper to be printed is placed in a box on top of the machine and feeds in continuously between the belts and the cylinder; or if only a few prints are wanted, previously cut sheets of paper may be fed in. The tracings are inserted between the paper and the cylinder, and, after passing around three-fourths the circumference

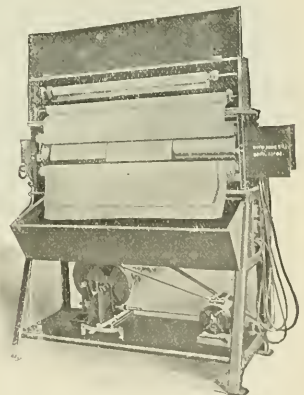

REVOLUTE BLUE PRINT MACHINE

of the cylinder, are deposited with the paper in a box in the front part of the machine, the printing being done from the inside of the cylinder as the paper and tracings travel around it.

It is possible to make prints 5 ft. wide and of any length whatever, and the device is adapted to making numbers of small prints on one long sheet of pa-

per or on previously cut sheets—which come out in a regular stream. A feature of this machine is that it is only necessary to handle one tracing at a time, the small ones being fed in side by side, while the paper feeds in automatically from a continuous roll.

The tracings go in and come out on the same side of the machine so that the leading edge of a tracing may be started into the machine again before the trailing edge comes out, thus saving time where more than one print is wanted from a tracing.

Another feature of the Everett-McAdam Machine, when calling it by the name of its makers, is the use of a num-

ber of one and a half inch belts instead of a single broad one. In this way better contact is obtained than with the use of a single broad belt.

The lamps used are well adapted to this kind of work as they give out chemical or actinic rays with almost no energy lost in the production of non-chemical light, and as the printing is done from the inside of the cylinder, the light strikes the paper at right angles, which is very desirable. The machine has thus a high efficiency. It is compact, requiring only a space 2x5 ft., and it is entirely self-contained. It is driven by a motor and the speed can be quickly changed to any

#### Band, Rip and Edging Saw.

Our illustration shows the new No. 202 Band Rip and Edging Saw, the latest product of the Fay & Egan Co., of Cincinnati, Ohio, in band machines. As a band rip saw it comprises all the features of their No. 180, and is built on

the column of that machine, with the same wheels and devices throughout, but with the added edging attachment feature, which consists of a traveling chain in the table and under the out-feeding roll, as depicted in the illustration. It is operated by sprocket chain and gearing from the same shaft that runs the upper-feed rolls. This traveling chain has a vertical adjustment, and can be quickly dropped below the surface of table to be out of the way for ripping.

This machine is free from vibration, as it is supported on a heavy, cored column. The distance between fence and saw blade will admit material up to 24 ins. wide. The rolls may be raised to receive timber 12 ins. thick. It has idler rolls fitted in the table to reduce friction. A cam

lever releases, moves and clamps the fence, accomplishing this adjustment very quickly.

This machine, like all other Fay & Egan band saws, has the patented knife-edge balance straining device, with forward, backward and side adjustment, this device being so sensitive that it instantly takes up slack in the blade under any condition of strain, and so permits running at high speed with entire safety to the blade, and consequent increase of output.

A man may hide himself from you in every other way, but he cannot in his work.—Ruskin.

## Tate Flexible Staybolt



Strong  
Effective  
Economical

Flexibility  
Durability  
Simplicity

Holds firebox sheets securely together, and accommodates itself to the unequal expansion of the plates.

## FLANNERY BOLT COMPANY

PITTSBURG, PA., U. S. A.

Suite 308, Frick Bldg.

B. E. D. STAFFORD, - - General Manager  
Write us for Reference Book



# THE UNION SWITCH & SIGNAL CO.

Consulting and Manufacturing  
Signal Engineers

Automatic Block Signals—Electric  
and Electro-Pneumatic

Interlocking—Electric, Electro-Pneu-  
matic and Mechanical

Electric Train Staff Apparatus

GENERAL OFFICES AND WORKS AT  
SWISSVALE, PA.

#### DISTRICT OFFICES:

New York: 143 Liberty Street  
Chicago: Monadnock Block  
St. Louis: Frisco Building

## DIRECTORY OF RAILWAYS OF THE WORLD

The Universal Directory of Rail-  
way Officials, published in Lon-  
don, contains a list of the entire  
railroads of the world, with physi-  
cal particulars and names of all  
officials.

Send Your Order Now  
for the 1906 edition.

Price \$3.00 Prepaid

A. FENTON WALKER  
Sole Representative for U. S.  
143 Liberty Street NEW YORK

## Compound Locomotives

By FRED H. COLVIN, M.E. Tells every-  
thing an engineer needs to know about  
all kinds of American compound loco-  
motives \$1.00.

ANGUS SINCLAIR COMPANY  
136 Liberty Street New York

## Odometer and Speed Recorder.

When you hear of a man speak of an odometer you must remember that he is dealing with a distance-measuring device. The word comes from the Greek "odos"—a way. An odometer gives the number of miles run. A speed-recording device gives you the number of miles made in a certain time. These two devices and a clock as well, are combined in an instrument known as the Bullard Speed Recorder.

This device has given satisfaction when applied to automobiles, and it is applicable to locomotives and railroad cars. The instrument is about 4½ ins. in diameter and looks very much like an air brake gauge. It can be attached so as to stand in any convenient position for reading and the connection is made by a flexible shaft and gears on

record on a detachable card. It shows every mile traveled, when and how long stops were made, and gives the total mileage. The price places it easily within the reach of all. If you are interested in a speed recorder which can be readily applied and to a locomotive, tender or coach, write a post card to J. H. Bullard, of Springfield, Mass., and he will give you some information that is valuable anyway.

## Prosperity Should Be Shared.

There has been a good deal said about the prosperity which has been smiling on the land for a number of years back. While it is true that participation in this prosperity has been shared in by nearly all the wage earners in America, whose scale of remuneration has steadily advanced, the pay of locomotive engineers has, as a rule, remained stationary. That the Brotherhood of Locomotive Engineers are alive to the fact is made manifest by a press dispatch from Chicago, which says: "Railroad engineers in Chicago and all over the West are voting on the question of accepting or rejecting the refusal of the managements of the trunk lines to grant demands that were made by the Brotherhood of Locomotive Engineers. The filing of the bill of grievances was made following a meeting of committees from engineers from each of the roads, west, north and south of Chicago, which was held at the Great Northern Hotel recently. The fact that the conference had

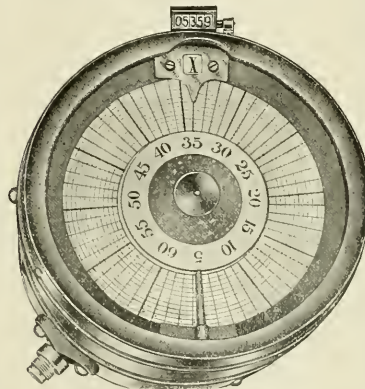

AUTOMATIC SPEED RECORDER

the axle. The dial is turned by a clock-work movement and makes one complete revolution each hour in the same direction as the hands of a watch, and it is divided into sixty radial lines representing minutes.

What the makers call the anvil "A" at the lower side of the instrument has a stylus behind it which makes a dot or perforation in the paper for each quarter mile traveled, no matter what the speed may be. This stylus is operated both by the clock and movement of the car, and is at the extreme outside space when the instrument is set for the beginning of a record. It moves towards the center, one space per hour, being actuated by the clock work and it takes twelve hours to move across the dial, where it is no longer operative until reset. Referring to our illustration, the dots may be seen. In this case they show a speed of fifteen miles per hour; as they are at exact minute intervals, thus indicating a mile in four minutes, the card shows the time the last perforation was made was 10.35.

This recorder makes a permanent

resulted in a bill of grievances and its presentation to the railroad officials, together with its subsequent rejection, was kept a secret by Grand Master Warren S. Stone, who presided, and also by the railway officials, and it was only recently that the fact leaked out that they had met with a flat refusal. The bill presented by the engineers includes demands for equalization of wages on roads west of the line of Winnipeg, Chicago and New Orleans, abolition of age retirement so long as men are physically competent and a modification of tests to determine efficiency of engineers as to vision, etc."

A pamphlet just published by the American Locomotive Company describes and illustrates a large number of 2-8-0 locomotives built for various railroads. This pamphlet includes only consolidation locomotives weighing less than 175,000 lbs., and will be followed shortly by a pamphlet illustrating designs of this type weighing more than 175,000 lbs. The pamphlet opens with

# World's Fair

St. Louis

FIRST PRIZE FOR

# TOOL STEEL

AWARDED TO

McInnes Steel Co.

CORRY, PA.

in competition with the best makes in England and Germany. Also manufacturers of all kinds of Tool Steel, Die Blocks, and Steel Forgings.

Write for Prices and Information

STANDARD MECHANICAL BOOKS  
FOR ROAD AND SHOP MEN  
BY CHAS. McSHANE

The  
Locomotive Up to Date

Price, \$2.50

New York and  
Westinghouse Air Brakes

Price, \$1.50

One Thousand Pointers for  
Machinists and Engineers

Price, \$1.50

All books bound in fine cloth

AGENTS WANTED everywhere; write for terms and descriptive circulars. Will be sent prepaid to any address upon receipt of price.

GRIFFIN & WINTERS  
171 La Salle Street, CHICAGO

a general description of the type, giving its distinguishing characteristics and its special advantages for heavy freight service or service on light rails where the wheel load is limited. Then follow four pages of tables giving the principal dimensions of thirty consolidation locomotives ranging in weights from 66,000 to 175,000 lbs., the tables being arranged in the order of the total weights of the locomotives. The next two pages show drawings of the side elevation and end elevation of a typical design of the 2-8-0 locomotive. The rest of the pamphlet is taken up with photographic reproductions of the locomotive given in the tables with the tabular information concerning the design on the page opposite each photograph. This is the third of the series of pamphlets which is to be issued by the American Locomotive Company, and will include all the standard types of locomotives and constitutes a record of the production of the company. Copies of the pamphlets already issued on the Atlantic, Pacific and Consolidation types may be had upon request to the company.

The Quincy-Manchester-Sargent Company, of Chicago, have issued a folder calling attention to their Tie Handling Tools. The device is called the Q. M. S., or the Cafferty tie tongs, and it is 33 ins. in length and weighs 10 lbs. The idea about the tie tool is that it takes a firm grip of the tie, something like the hold an ice tongs can take on a bit of high-priced frigidty, and the tie can be pulled about by the use of the tongs without making any holes in the face of it, as is usually done when an old dull pick is used. The pick holes gave a chance for the entrance of moisture, which starts decay. The tongs grip firmly, but do not leave a mark. If you would like some information on the subject drop the company a post card.

### One of the Reasons.

If you should happen to notice any of the pictures or should read any of the verses which describe Miss Phoebe Snow you will find that the conductor of the train she travels by, is a fine fellow, the engineer is all right, and, by the way, he is a regular reader of RAILWAY AND LOCOMOTIVE ENGINEERING; that the fireman handles the scoop filled with anthracite and fires light and often; the brakeman is prepared to go back more than 8 telegraph pole spaces in case the train is stalled, for Phoebe's sake; and the porter on the dustless road is not jet black, but only a dull brown. You will also observe that the train dispatcher is a thoughtful man who knows what he is about, and the man in the interlocking signal tower, like pretty much everything in the signal department, is

This illustration shows the form of construction of the

## Dart Patent Union

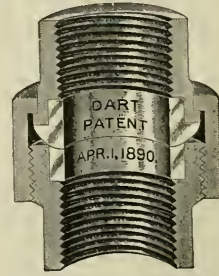

Every feature of construction represents the best points to insure stability and durability. The malleable iron pipe ends and nuts, in combination with bronze metal seats, are as near perfection as is possible to approach, and the sales to date indicate the public approval. There are none so good. For sale by all the principal jobbers in United States, Canada and Europe.

E. M. Dart Mfg. Co., Providence, R. I.  
FAIRBANKS CO., SALES AGENTS.



## The Twentieth Century Master Mechanic

Won't use Solid Mandrels.  
Cost too much, take up too  
much room and don't give  
satisfaction.

### Nicholson Expanding Mandrels

Take everything from 1 to 7  
inch holes. Take up little  
room — always ready and  
you can buy four sets for  
the cost of one of the solid  
kind

### Are You Using Them?

Catalogue tells you  
more about them.

W. H. Nicholson & Co.  
Wilkesbarre, Pa.

# One Year and Eleven Months'

## SERVICE

WITHOUT REPACKING, ON

### HIGH-PRESSURE LOCOMOTIVES

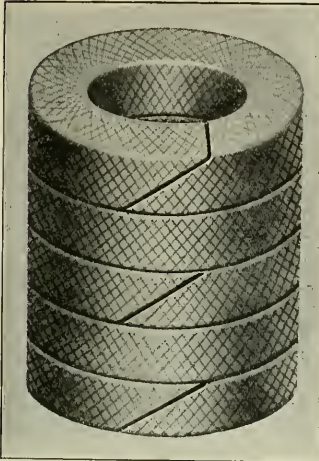

Style 300 TV.

A throttle failure is an absolute impossibility where Crandall's Throttle Valve packing is used.

IT WILL NOT BLOW OUT

## Crandall Packing Co.

FACTORY AND GENERAL OFFICE

PALMYRA, - NEW YORK

BRANCHES

New York  
136 Liberty St.

Chicago

52 West Washington St.

Cleveland  
9 So. Water St.

# Patents.

GEO. P. WHITTLESEY

McGILL BUILDING WASHINGTON, D. C.

Terms Reasonable. Pamphlet Sent

## Molding Machines

Vertical Vibration. Power Draft

ALL KINDS OF MACHINES

THE E. H. MUMFORD CO.

17th & Callowhill Streets, PHILADELPHIA, PA.

J. W. JACKMAN & CO., Ltd., 39 Victoria St. London, S. W.

up to date, and he does his work in a straightforward and businesslike way.

All this you may see in the posters, or you may find it out if you travel on the Lackawanna, but there is one secret which we would like to let you into, and that is another of the reasons for the dazzling whiteness of Phoebe's dress—that is the way we usually speak of ladies' costume, but we acknowledge that "smart frock" is the modern phrase—perhaps you think that the dustless road is responsible; so it is in part, but on the Lackawanna, although the engines make no smoke, there is now and then a certain amount of bad, wicked dust trying to blow in on the right of way from some outsider's property, and to prevent even this insignificant quantity from finding a lodgment in the cars, the Lackawanna has lately installed the Vacuum Cleaner Company's system. Cars are cleaned without any dust being stirred up, and what dust there is, is quietly and quickly sucked up into the flat duck bill at the end of a coil of rubber hose, which the car cleaner uses. Such dust as may have crept in when nobody was looking, disappears for good and all in the twinkling of an eye. The cars are thoroughly clean, and no joking about it, when Miss Phoebe Snow takes her place, resolved to go upon a trip to Buffalo. If you want further particulars write the Railroad Department of the Vacuum Cleaner Co., 427 Fifth avenue, New York, and ask to be informed about the car cleaning system now used. Miss Phoebe thinks it is now up to the Lackawanna to get out a new poster and another verse in order to put the public "next" to one of the principal reasons.

### Uniformity in Signals.

A very important move toward uniformity of railroad operation was recently made when the Railway Signal Association, in session at Washington, approved a change in signal colors and positions governing the movement of trains. The association approved the use of a green light at night for "proceed," yellow for "caution," and red for "stop." The use of the upper right hand quadrant for semaphore indications for day was also approved. There is, however, a great number of roads that are still using white for "proceed," green for "caution." The association is working for a uniform signal system in colors for all lines.

In eighteen months Oregon has furnished between 40,000,000 and 50,000,000 ft. of fir lumber for use in the construction of cars at the shops of the Pullman Co., at Pullman, Ill. In the purchase of this material the company has expended nearly \$1,500,000.—New York Commercial.

## METAL PRESERVATIVE PAINTS AND PRIMER

for locomotives, boilers, stacks, front-ends, gearing, framework, metal roofs, etc.

Tell us your needs.

Metal preservative paints have been our specialty for 22 years.

Paints for all conditions.

THE  
**STANDARD PAINT CO.**  
Sole Manufacturers

100 William St., New York  
CHICAGO ST. LOUIS

### CONTENTS :

	PAGE.
*Concrete Viaduct .....	491
*Railway Shops on the Prairie, Can. Pac. Ry. 492	492
*Engine Failures and Their Causes. F. P. Roesch .....	496
*General Correspondence .....	499
Regular vs. Pooled Engines.....	504
Book Notices .....	509
*Patent Office Department.....	510
*Our Correspondence School.....	511
Questions Answered .....	513
Fraudulent Dipsonania Cures.....	514
Gives Way to a Railroad.....	514
*Air Brake Department.....	515
*Tunnels Under the Hudson.....	516
Respecting Signals .....	518
*Walschaerts Valve Gear.....	510
Observations on Flexible Stay Bolts, B. E. D. Stafford .....	520
Proposed Railroad Museum.....	521
Setting Flues in Locomotive Boilers.....	522
Cast Iron for Cylinders.....	522
Personals .....	523
Railroad Car Cleaning.....	525
Great Men .....	530
*Odometer and Speed Recorder.....	533
One of the Reasons.....	534
Uniformity of Signals.....	535
Locomotives:—	
*Birmingham Southern, 2-8-0.....	495
*Three Cylinder Compound, Gt. Cent. of England .....	504
*Culm Burner, 2-8-0, for the D. & H.....	517
*Rack Rail Locomotive, Manitou & Pike's Peak .....	527
Editorials:—	
Traveling Engineers and Front Ends.....	506
Pennsylvania Railroad Collision.....	507
Points of View.....	507
Free Technical Schools.....	507
British Railway Disasters.....	508
Exhibition of Safety Devices.....	508
The Future Engineeman.....	508
Cars:—	
*Motor Coach, New (Glasgow).....	494
*Ballast and Sleeper Wagons, A. R. Bell.....	503
*Caledonian Motor Car Van.....	528
Shops and Shop Appliances:—	
*Canadian Pacific Shops at Winnipeg.....	492
*Chuck for Flat Drills (Big Four).....	498
*Cutterhead Brace, Penna.....	528
*Cylinder Patched .....	530
*Blue Print Machine.....	531
*New Band Rip Saw.....	532

TRADE MARK  
The Sargents Glove



"WRIST OR GAUNTLET"

TRY THEM

They are made for hard wear from the very best grade of chrome tanned heat and water proof horsehide leather. No rivets nor seams to hurt the hands.

If your dealer does not carry "Sargents" we will sell you direct on receipt of your size and \$1.00

Write for free leather match safe and descriptive booklet

DETROIT LEATHER SPECIALTY COMPANY, Detroit, Mich.

TALMAGE SYSTEM

A MECHANICAL SYSTEM FOR LOCOMOTIVES THAT OVERCOMES THE BAD EFFECTS FROM THE USE OF UNDESIRABLE FEED WATERS

PATENTED IN UNITED STATES AND FOREIGN COUNTRIES

RUBRA BOILER OIL  
TALMAGE BLOW OFF VALVES

USED IN CONNECTION

GUARANTEE

WE GUARANTEE TEN TIMES GREATER MILEAGE BETWEEN BOILER WASHINGS AND TO REDUCE MOTIVE POWER EXPENSES SUFFICIENT TO MAKE THE COST OF OUR SYSTEM PERMISSABLE.

THE TALMAGE MANUFACTURING COMPANY  
CLEVELAND, O., U. S. A.

J. G. TALMAGE, President

INDEX TO ADVERTISEMENTS.

Acme Machinery Co. . . . .	Front Cover	Davis, John Co. . . . .	23	Nicholson, W. H., & Co. . . . .	534
Air Brake Chart. . . . .	—	Detroit Leather Specialty Co. . . . .	536	Niles-Bement-Pond Co. . . . .	3
Ajax Metal Co. . . . .	4th Cover	Detroit Lubricator Co. . . . .	13	Norton Grinding Co. . . . .	1
Aldon Co. . . . .	—	Detroit Seamless Tube Co. . . . .	21	Norwalk Iron Works. . . . .	14
American Balance Valve Co. . . . .	4th Cover	Dixon, Joseph, Crucible Co. . . . .	525	Pacific Trading Co. . . . .	18
American Brake Shoe Co. . . . .	15	Ekert High Resistance Co. . . . .	26	Pennsylvania R. R. . . . .	—
American Loco Sander Co. . . . .	530	Expanded Metal Co. . . . .	3	Pittsburgh Spring & Steel Co. . . . .	2
American Locomotive Co. . . . .	8	Falls Hollow Staybolt Co. . . . .	14	Porter, H. K., & Co. . . . .	17
American Locomotive Equipment Co. . . . .	4th Cover	Fay & Egan Co., J. A. . . . .	11	Pratt & Whitney. . . . .	—
American Valve and Meter Co. . . . .	—	Fitz Hugh Luther Co. . . . .	—	Pressed Steel Car Co. . . . .	10
Armstrong Bros. Tool Co. . . . .	2d Cover	Flanders, L. B., Machine Works. . . . .	16	Prosser, Thos., & Son. . . . .	16
Armstrong Mig. Co. . . . .	8	Frankery Belt Co. . . . .	2	Quincy, Manchester Sargent Co. . . . .	528
Audel, Theo., Co. . . . .	5	Franklin Mig. Co. . . . .	2	Railway Materials Co. . . . .	2d Cover
Baker, Wm. C., Heating and Supply Co. . . . .	5	Galena Signal Oil Co. . . . .	2	Railway Steel Spring Co. . . . .	10
Baldwin Locomotive Works. . . . .	10	Garlock Packing Co. . . . .	18	Ralston Car Co. . . . .	4
Ball Webb, C. Co. . . . .	—	General Electric Co. . . . .	19	Reverse Rubber Co. . . . .	3d Cover
Barnett, G. & H., Co. . . . .	2d Cover	Gold Car Heating Co. . . . .	529	Rogers, H. A., Co. . . . .	14
Barratt, Machine Tool Co. . . . .	—	Goodrich Rubber Co. . . . .	9	Rogers Locomotive Works. . . . .	17
Bettendorf Axle Co. . . . .	24	Gould Coupler Co. . . . .	18	Rue Mig. Co. . . . .	18
Big Four Railroad. . . . .	—	Greene, Tweed & Co. . . . .	2d Cover	Safety Car Heating & Lighting Co. . . . .	11
Big, Frank. . . . .	—	Hancock Mig. Co. . . . .	53	Saunders, D., Sons. . . . .	14
BOOKS.—	—	Henley & Co. . . . .	527	Scandinavia Belting . . . . .	15
Air Brake Chart. . . . .	—	Hicks, F. M., & Co. . . . .	14	Sellers, Wm., & Co., Inc. . . . .	2
Compound Locomotives. . . . .	—	Hoffman, Geo., W. . . . .	18	Sight Feed Oil Pump Co. . . . .	2
Computers. . . . .	25	Homestead Valve Mig. Co. . . . .	530	Skat Mig. Co. . . . .	528
Conger's Air Brake Catechism. . . . .	—	Hunt, Robert W., & Co. . . . .	530	Slocumb, F. F., & Co. . . . .	528
Firing Locomotives. . . . .	26	Illinois Central R. R. . . . .	—	Smooth-On Mig. Co. . . . .	9
Locomotives Running and Management. . . . .	9	International Correspondence Schools. . . . .	9	Southern Pacific R. R. . . . .	14
Machine Shop Arithmetic. . . . .	20	Jenkins Bros. . . . .	4th Cover	Standard Car Truck Co. . . . .	2d Cover
Miscellaneous. . . . .	20	Johns-Manville, H. W., Co. . . . .	526	Standard Coupler Co. . . . .	15
Oil Burning in Locomotives. . . . .	18	Kennicott Water Softener Co. . . . .	5	Standard Paint Co. . . . .	535
Train Rules and Train Dispatching. . . . .	8	King-Lawson Car Co. . . . .	3d Cover	Standard Steel Works. . . . .	10
Twentieth Century Locomotives. . . . .	8	Kinnear Mig. Co. . . . .	2d Cover	St. Louis Car Co. . . . .	21
Bordo, L. J., Co. . . . .	531	Lake Shore. . . . .	16	Star Brass Mig. Co. . . . .	9
Boston & Maine R. R. . . . .	9	Lackawanna R. R. . . . .	16	Starrett Co., L. S. . . . .	19
Carpenter, The J. M., Tap & Die Co. . . . .	9	Lake Shore. . . . .	17	Storrs Mica Co. . . . .	534
Central R. R. of New Jersey. . . . .	7-17	Latrobe Steel & Coupler Co. . . . .	8	Symington, T. H., & Co. . . . .	7
Chalfonte Hotel. . . . .	1	Lexington Hotel. . . . .	7	Swift Paint Co. . . . .	19
Chapman Jack Co. . . . .	7	Locomotive Charts: . . . . .	—	Tabor Mig. Co. . . . .	536
Charts.—	—	Atlantic Type. . . . .	1	Talmage Mig. Co. . . . .	536
Combination Passenger & Sleeping Car. . . . .	12	Locomotive Publishing Co., Ltd. . . . .	16	Underwood, H. B., & Co. . . . .	16
Locomotive, Atlantic Type. . . . .	9	Long & Alistater Co. . . . .	17	Union Pacific R. R. . . . .	7
Locomotive, American Type. . . . .	9	Magnus Metal Co. . . . .	4	Union Switch & Signal Co. . . . .	533
Chicago Car Heating Co. . . . .	13	Manning, Maxwell & Moore. . . . .	2	United States Metallic Packing Co. . . . .	23
Chicago Pneumatic Tool Co. . . . .	16	McConway & Torley Co. . . . .	13	Utica Steam Gauge Co. . . . .	—
Chicago & Alton R. R. . . . .	18	McCord & Co. . . . .	2d Cover	Vacuum Cleaner Co. . . . .	13
Cleveland City Forge & Iron Co. . . . .	4th Cover	McInnes Steel Co. . . . .	534	Van Duzen Co. . . . .	10
Cleveland Twist Drill Co. . . . .	4th Cover	Mere-Jones Brass and Metal Co. . . . .	11	Van Iron Works. . . . .	25
Climax Bearing Co. . . . .	8	Morse Twinst Drill Co. . . . .	8	Walker A. Fenton . . . . .	533
Commercial Acetylene Co. . . . .	24	Mumford, The E. H., Co. . . . .	535	Walworth Mig. Co. . . . .	2d Cover
Commonwealth Steel Co. . . . .	3	Munn & Co. . . . .	—	Washburn Co. . . . .	4th Cover
Consolidated Railway, Electric Lighting & Equipment Co. . . . .	8	National Am. Mig. Co. . . . .	15	Watson-Sillman Co. . . . .	4th Cover
Crandall Packing Co. . . . .	535	National Malleable Castings Co. . . . .	4th Cover	Westinghouse Air Brake Co. . . . .	6
Damascus Bronze Co. . . . .	23	New York Asbestos Co. . . . .	15	Westinghouse Electric & Mig. Co. . . . .	7
Dart, E. M. Mig. Co. . . . .	534	New York Central R. R. . . . .	19	Westinghouse Foundry Equipment Co. . . . .	22
				Whittlesley Geo. P. . . . .	535
				Williams Typewriter Co. . . . .	14
				Wood, R. D., & Co. . . . .	7
				Zephron Chemical Compound Co. . . . .	15

# Railway and Locomotive Engineering

Copyright by Angus Sinclair Co.—1906

## A Practical Journal of Railway Motive Power and Rolling Stock

Vol. XIX.

136 Liberty Street, New York, December, 1906

No. 12

### Arched Structures.

Very little is known as to the origin of the arch. It is supposed to have been devised by builders in very ancient times, more or less by accident.

of stresses which stone is not well able to bear.

Some authorities suppose that when builders in early days found a flat stone lintel had been broken, the masons in the

shaped stones is thought to have been the natural development from the rudimentary arch formed by the two pieces of broken stone lintel.

Arched apertures have been contrived



RAILROAD BRIDGES OVER THE NIAGARA GORGE. THE CANTILEVER AND THE STEEL ARCH

The oldest method of carrying a wall above an opening for a door was the use of a flat stone supported at its ends. The weight resting on this flat stone or lintel had a tendency to break it down in the center, as its upper surface was necessarily in compression and its under side was in tension, which are forms

process of repair used the broken pieces again, but set them at an angle to each other so that the broken edges came together, and in this way secured a door opening with a triangular top, and of greater strength than the solid flat stone had been before. The subsequent use of three or more wedge-

in ancient buildings, formed by the stepping out of the end stones of several courses of masonry, and the beveling off of their lower corners. This form of building had in it nothing of the principle of the arch, and these arched apertures were not used extensively enough to warrant the belief that they

were in any sense part of any prevailing style of ancient architecture.

The round arch seems to have been distinctly Roman or possibly Etruscan. The Romans prior to their conquest of Greece took many of the arts from Et-

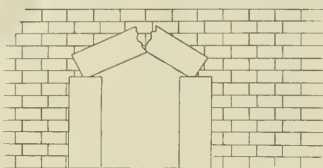

POSSIBLE ORIGIN OF THE ARCH

ruria, and among them the round arch may have come. It was readily used by the Romans as affording a means of covering wider spaces than were possible with flat stones. The Roman quarries did not produce stones of great length, and the arch principle was probably all the more readily adopted on that account, and moreover the arch form of construction was found to be self-supporting and its stability was rather increased by the addition of weight. The Romans undoubtedly were the first people to make extensive practical use of this form.

The arch survived by reason of the fact that it was based upon sound engineering principles and has been employed in the early days of bridge build-

ing. The moving load were regarded as insignificant. Perhaps the strongest form of arch, when used in bridge building, is that of an arc of a circle where the rise is about one-quarter of the span and where the arch springs from its abutments at a point above that where rupture would theoretically take place if the sweep of the circle had been produced. In metal arch bridges, however, the moving load usually produces proportionally greater stresses than in masonry arches, as in metal bridges the permanent load is lighter in proportion to the span and the roadway is not usually as heavy.

The frontispiece which we show this month gives a view of the magnificent steel arch which spans the Niagara gorge. In the foreground, and crossing the sky line of the picture, is the Cantilever bridge on the line of the Michigan Central Railroad. The steel arch is used not only by the Grand Trunk Railway but the lower floor of the bridge is used as a roadway for foot passengers and vehicles, and a trolley line runs in the center, below the railway tracks.

The steel arch has a clear span of 550 ft. and the rail level is about 226 ft. above the waters of the Niagara river. The lower chord of the arch itself is a parabola. That is a mathematical curve of the same kind as is used in locomo-



STONE ARCH USED IN MODERN RAILWAY WORK

ing. The masonry arch practically depends for its stability on the existence of a permanent load and many stone or brick arch bridges have been built in which the superincumbent weight was so great that the stresses occasioned by

tive headlights. It is one of the conic sections and is formed when a cone is cut by a plane parallel to its sloping edge. The shore spans at each end of the main arch are each 115 ft. long and are Pratt truss bridges.

The top chord of this steel arch is an unbroken straight line, while the lower chord forms the beautiful sweeping arch which reaches from shore to shore. The bridge itself is composed of two trusses which lean inward toward one another, with a batter of one in ten. The space on top is about 35 ft. wide and is sufficient to comfortably carry two railroad tracks and the bridge is therefore about 24 ft. wider where it rests on the abutments than it is at the

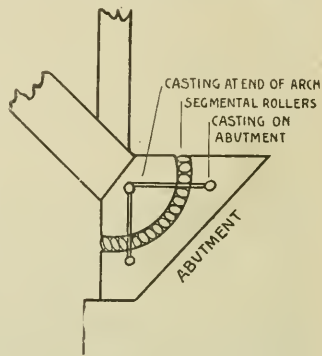

POINT FROM WHICH ARCH SPRINGS

upper floor. This gives the structure great stability in resisting wind stresses.

The arch is continuous, and is built entirely of members securely riveted together. There is not a pin or movable joint connection in the whole arch. It is, however, in a sense, hinged at the abutments. These are built of stone, at an angle of 45 degrees. The end of each arch truss terminates in a casting having a rounded outer edge, made to a radius of 3 ft. 6 ins. This casting rests on a nest of segmental rollers which insures the equal distribution of weight on the masonry. The rollers rest upon a casting which is curved to suit the radius of the arch terminal. This casting bolted securely into the abutments weighs 35 tons. The ends of the steel arch may therefore be said to rest upon hinges, resembling in section the form of a ball and socket joint.

This steel bridge was erected round the suspension bridge which it replaced, and being considerably wider, was built without touching the old bridge or in any way interfering with traffic. The bridge is, as we have said, a continuous steel arch, but it was erected on the cantilever principle. The shore panels of the arch were erected on false work, and to the top of the first post, the top chord of the Pratt truss bridges were fastened and these were carried back and suitably anchored to the solid rock on the bank. A toggle was interposed close to the anchorage so that by spreading the toggle the upright post resting on the hinge at the abutment

could be moved out of the perpendicular as required. The top chords of the Pratt trusses thus became, in each case, chains by which the panels were held upright as each was built out over the stream, and the anchorage sustained the weight during the period of con-

### Old Time Railroad Reminiscences.

BY S. J. KIDDER.

In the January number of *RAILWAY AND LOCOMOTIVE ENGINEERING* was related my first air brake experience on a prominent western trunk line, and I spoke of

state of affairs was understood by the higher officials of the road that little time would elapse before they would realize that radical action in the way of improved brake service was essential to a safe conduct of the company's business, so far as the running of trains was concerned.

It must be confessed that I did not look for much encouragement from the head of the motive power department, knowing as I did his propensity for blue-penciling requisitions for G-6 brake valves, sent in each month by a progressive master mechanic located at a remote point on the road and the fact, too, that the S. M. P. had finally written this official that when he wanted any brake valves he would, himself, give instructions to that effect. In time, however, the looked for opportunity presented itself, as a change of management took place and the new officers were not slow in observing the generally deficient brake conditions prevailing, a result of which, to me, was an invitation to visit the road, a request I very promptly accepted. Reaching headquarters I was met by one of these new officials who had, by the way, a considerable knowledge of automatic brakes, though somewhat limited from a practical standpoint, but who fully appreciated the serious conditions and was

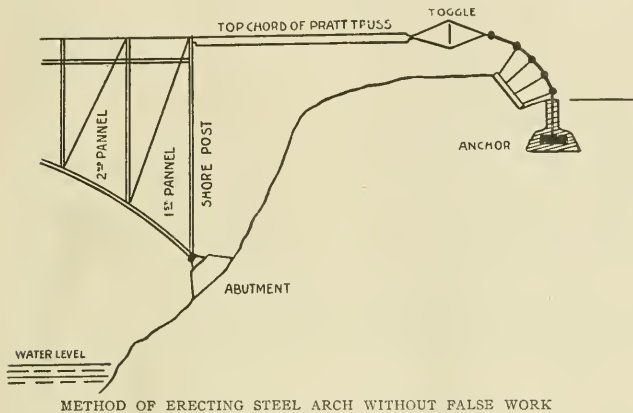

struction. The pull on the anchorage was about 1,060,000 lbs. on each chain and sustained one, half-truss of the arch. Each toggle was expanded or contracted by the movement of a cast iron nut turned by six levers each 11 ft. long. Both double arches were built out over the water without the use of false work and finally met in midair far above the stream. When the arches were finally completed, the anchorage system was removed and the bridge became self-sustaining.

The shore spans or Pratt truss bridges are entirely independent of the main arch. They are attached to the first post of the shore panel of the arch, by a pin through the top chord and their shore ends rest upon rollers. They are thus free to move without straining the arch.

The length of the structure is made up of 550 ft. arch span, two shore spans each 115 ft. long and two approaches each 145 ft., making a total of 1,070 ft. in all. The total weight of the bridge is 7,200,000 lbs. Under a test load of 5,200,000 lbs. the arch deflected one inch.

The arch was designed by Mr. L. L. Buck, of New York, and the work was done by the Pennsylvania Steel Company in 1897. During the building of this magnificent structure, stretched like the bow in the clouds, above the surging flood, not a single human life was lost. The bridge builders after so successfully bringing this notable achievement to completion, might almost with propriety have inscribed upon their work that line from Ovid: "Exitus acta probat"—"The event approves the acts."

the drawbacks then existing which prevented my exercising any good offices, with a view of correcting the numerous deficiencies which were apparent in matters pertaining to air brakes, and which contributed to constant danger in train handling and at the same time seriously



STEEL ARCH REPLACING SPIDER-LEGGED WOODEN STRUCTURE

reflected on the brake apparatus itself. I had watched this condition of affairs with very great interest, meanwhile frequently indulging the hope that something might turn up which would open the way to my getting in touch with the situation, as I felt sure when the real

most anxious for their prompt correction. In company with him a call was made on the general manager, during which time the subject of air brakes was very fully canvassed, and in reply to numerous questions I was quite able to point out and criticize the general air





laughter, and, on some of the faces, a look of disgust was apparent. In response to an invitation the oldest man stepped to the front and with the remark "he guessed he was the fellow I wanted," placed his hand on the three-way cock handle.

"How long have you been handling a three-way cock?" I inquired.

"Twenty-two years," he replied.

"What kind of service?"

"Passenger trains."

"Do you ever have any trouble when there is a quick action brake in the train?"

"Yes, but the trouble don't come from the three-way cock, for the brakes work all right when we don't have any of your dynamite triples."

While this colloquy was going on, I signaled my assistant to give us three cars, then requested the engineer to imagine himself making a know-nothing stop with a service application, and which he proceeded to do, but almost simultaneous with the movement of the three-way cock handle the brakes went

stant fear that someone would venture the remark that he couldn't tell how to handle the brakes, not knowing how many were operating, but, fortunately for me, the question was not raised until a later and opportune time when it aided in making the object lesson more forcible.

As the erratic performance of quick action brakes when handled with a three-way cock had by this time been pretty well exploited, and the causes therefor explained, the G-6 brake valve was substituted, followed by an explanation of its characteristics, what each notch of the brake valve handle spring quadrant signified and that the handle could be moved slowly or quickly from one position to another with no bad results, after which the engineer was requested to make a service application as attempted with the three-way cock, the three cars being cut in as in the first experiment.

To the surprise of all, the brakes responded properly a number of times, and while explaining the piston valve

I had just started to go into a more detailed comparison of the two valves when up jumped an engineer, who exclaimed: "You said you could handle the brakes better with a three-way cock than he did."

"I did say that, didn't I?" and thereupon the three-way cock was again brought into action and I proceeded to operate the brakes of the three and twenty car trains respectively and which, of course, was a comparatively easy matter, knowing as I did the number of brakes I was contending with.

That object lesson was a productive one, as by making good my assertions and delivering the goods the confidence of the men was gained, but in the several weeks I spent with the instruction outfit not another man could I get before the class to operate a three-way cock. Much interest followed the opening day and among my most pleasant air brake recollections is that of the time spent among those men who at first had looked upon my advent on the road as a sort of disorganizer of fixed

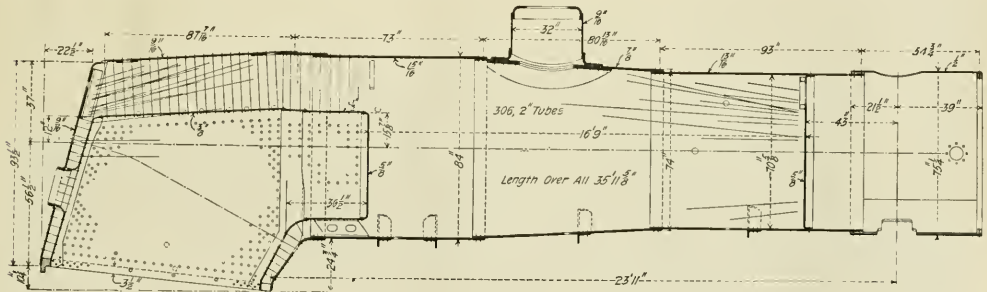

BOILER OF NORTHERN PACIFIC 4-6-2 ENGINE, SHOWING COMBUSTION CHAMBER

on with an emergency application. After a release and re-charge, a second attempt was made with like result, but the third time he managed by sufficiently restricting the discharge from the train pipe to get a service application.

Following this, and while explaining the cause of the brake's erratic performance I signaled to cut in the entire train, then asked to have the know-nothing stop repeated.

This brought more trouble, for, in three attempts, the brakes failed to respond, and, when they did finally apply, the five head ones released upon lapping the three-way cock. After considerable experiment and explanation, with extreme care in moving the handle to lap, the brakes all applied and remained set and upon releasing a signal was again given to cut off all but three cars and a number of service applications were followed with quick action.

By this time my pupil was laboring under considerable excitement, with great beads of perspiration coursing down his face, while I, too, was in con-

operation in the brake valve the twenty cars were cut in and brakes applied, and, as before, my assertion was verified that he could do better braking the first time he handled the brake valve than with all his three-way cock experience.

"I give it up," he said, "you have called the turn, and I don't go up against any more air brakemen in this business." He took his seat, and as he did so, one of the men said, "Say, Mr. K., you didn't give him a fair show." "In what way?" I asked.

"Why, you did not tell him how many brakes he was handling."

"Did he get good results with the three-way cock?"

"No."

"How about the 'new fangled' brake valve?"

"Brakes worked bully, so far as I could see."

"Well," I said, "the number of brakes operated with the new valve was identical to those in the first attempts and you observed my assertions have been verified to the letter."

traditions, but who, as they became familiar with the new air apparatus, were not slow in taking advantage of the opportunity afforded them to become proficient with its construction and operation. Further than this, all engines and cars passing through the shops came out with the proper apparatus, and in the course of time the equipment of the road was in a condition to compare favorably with that of their most progressive neighbors.

Among my files is a letter written me a year after the instruction car made its advent in which, after relating the progress made in air brake matters, goes on to state that during that year the saving in skid wheels alone more than paid the entire cost of replacing the old apparatus with modern brake appliances.

While railroads are clamoring for delivery of new freight cars from the several car works in the country, the car companies complain that the railroads cannot bring them the materials to make the cars fast enough.—N. Y. Commercial.

Balanced Compound for the N. P.

The Northern Pacific Railway has just received from the Schenectady works of the American Locomotive Company two Pacific type or 4-6-2 passenger engines built with four cylinders and in the form of a balanced compound. The en-

on the cranks of the leading driving axle.

This arrangement was used in order to obtain a proper length of high pressure main rod without any radical change in length of wheel base and boiler, from the simple Pacific type

similar increase in length of boiler and tubes, or to have used a bifurcated high pressure rod, straddling the forward axle.

The main valves for all the cylinders are of the piston type, 14 ins. in diameter. There are four valves, and each pair are tandem. They are in a horizontal

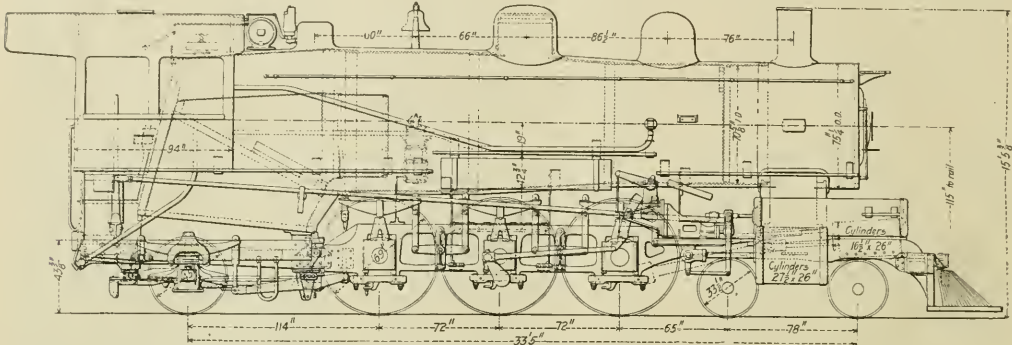

GENERAL PLAN OF NORTHERN PACIFIC BALANCED COMPOUND

gine, which we illustrate, is one of these engines and, besides being interesting from the standpoint of design, it has the distinction of being the forty thousandth locomotive turned out by the builders. Although in its distinguishing features it represents no new or untried principles, it combines in one engine probably the latest development in locomotive design in this country. The features of the engine are the four balanced compound cylinders, the boiler with combustion chamber and the Walschaerts valve gear.

The cylinders are 10 1/2 and 27 1/2 ins. by 26 ins. stroke, and the driving wheels are 69 ins. The calculated tractive pow-

er is 30,340 lbs., and with 157,000 lbs. on the driving wheels, the ratio of tractive effort to adhesive weight is as 1 is to 5.17. The low pressure cylinders are outside and are in the usual position, their pistons drive on the crank pins of the rear driving wheels. The high pressure cylinders are set forward and lie at a slight angle, and their pistons drive engines of the same road. By placing the high pressure cylinders at a slope of 1 in 15 and extending the front end of the boiler, keeping the length of the flues the same as in the simple Pacific type engines referred to, a length of high pressure main rod of 91 1/4 ins. was obtained. The angle at which the high pressure cylinder is placed is such that it gives ample room above the truck, not only for the cylinders itself but for the cylinder cock rigging. There is no gain in power by reason of the slope of the high pressure cylinders, and the only reason it has been done is to give room above the truck and keep the longitudinal center line of the

position, and are actuated by Walschaerts gearing. The fact that this valve gear is outside, has been taken advantage of in order to brace the frames together by means of a heavy steel casting, which is bolted to and flanged against the frames. The frame is made all in one piece, and is composed of cast steel. On account of the use of the Walschaerts valve gear, very strong frame bracing was possible. Instead of the usual waist sheet cross ties, a heavy steel casting is bolted between the frames over the middle driving axle, and the waist sheets are bolted to each end of this casting. The waist sheets extend down and are bolted at the bottom end to steel cross ties ex-

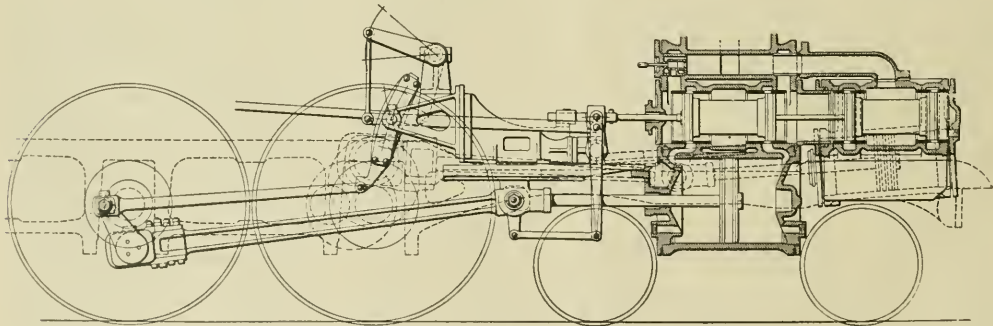

VALVE GEAR AND CYLINDER ARRANGEMENT, NORTHERN PACIFIC 4-6-2

er is 30,340 lbs., and with 157,000 lbs. on the driving wheels, the ratio of tractive effort to adhesive weight is as 1 is to 5.17. The low pressure cylinders are outside and are in the usual position, their pistons drive on the crank pins of the rear driving wheels. The high pressure cylinders are set forward and lie at a slight angle, and their pistons drive

cylinders directed toward the center of the forward driving axle. With the four cylinders in the same transverse plane, it would have been necessary, in order to obtain a satisfactory length for the high pressure main rod, to have either increased the distance between the center of cylinders and the forward driving wheels from 30 to 36 ins., involving a

tending across the lower rails of the frames front and back of the main pedestals.

The pedestal binders are also steel castings which pass round the outside of the bottom of the jaws. They are held in position by a pair of small bolts, but the holding power of the binder is secured by a pair of wedge pieces front

and back, which, when pulled into position by a bolt and nut, clamp the ends of the pedestals between the spacing piece which forms the centre of the binder, so that everything is held perfectly rigid.

The springs are overhung and easily got at, and the weight on the drivers is equalized together and also equalized with the trailing truck wheels. The driving wheels are all flanged and are equally spaced, being exactly 72 ins. apart. The trailing truck wheels are 45 ins. in diameter. This truck has outside journals it has a self-centering device at the back which enables the truck to swing back into place when coming off a curved piece of track to a tangent. The reach rod in this engine is a piece of wrought pipe supported on a roller in the center. It is, in consequence, light and stiff. An electric head light is used on this engine.

The advantageous features claimed for

per hour, and 1,980 at 75 miles per hour, while the original simple engine developed from 1,400 to 1,500 H. P. The other advantages are the subdivision of power between four cylinders and between two axles, reduction of bending stresses on the crank axle due to the fact that only half the turning moment is transmitted through each axle and the advantages of light moving parts which will minimize wear and repairs.

The boiler is of the extension wagon top type with first ring 72½ ins. in diameter. The steam pressure is 220 lbs. per sq. in. The heating surface is 2,908.8 sq. ft. in all, which is made up of 2,667 in the tubes, 232.9 in the fire box, including the combustion chamber, and 8.9 sq. ft. in the arch tubes. The grate area is 43.5 sq. ft., which gives a ratio to heating surface as 1 is to 68. There are 306 tubes, 2 in. in diameter and 16 ft. 9 ins. in length. The combustion chamber is approximately 36½ ins. deep, and

The tender frame is composed of 13-in. steel channels; the tank has a water bottom and will hold 7,000 U. S. gallons. The fuel capacity is 12 tons. The engine is a handsome machine, and when the output of the ten locomotive building shops since the inception of each is added together, this engine is the forty thousandth locomotive built by the owning company. Some of the principal dimensions are as follows:

Axles—Driving journals, main, 11x11½ ins.; others, 9½x12 ins.; engine truck journals, diameter, 6½ ins.; length, 12 ins.; trailing truck journals, diameter, 8 ins.; length, 14 ins.; tender truck journals, diameter, 5½ ins.; length, 10 ins.

Boiler—Fuel, bituminous coal.

Fire Box—Type, wide; length, 96 ins.; width, 65½ ins.; thickness of crown, ¾ in.; tube, ¾ in.; sides, ¾ in.; back, ¾ in.; water space, front, 4½ ins.; sides, 4 ins.; back, 4 ins.; crown staying, radial.

Tubes—Diameter, 2 ins.; No. 11 B. W. G.

Engine Truck—Four-wheel swing center; W. I. frame; trailing truck, radial type with outside journals.

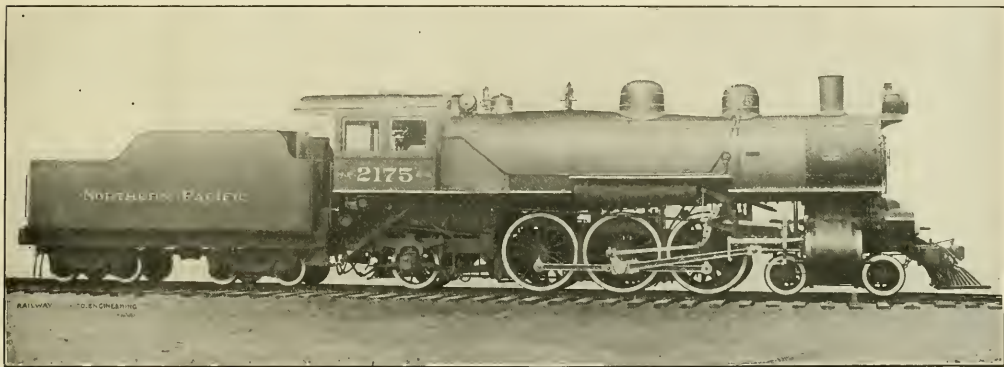

NORTHERN PACIFIC RAILWAY FOUR CYLINDER BALANCED COMPOUND

W. Moir, Mechanical Superintendent

American Locomotive Co., Builders

the four cylinder balanced compound engine are: The approximately correct balance of the reciprocating parts combined with the almost perfect balance of the revolving weights and a permissible increase of weight on driving wheels on account of the elimination of the hammer blow. In this engine an increase of 11,000 lbs. on driving wheels over that of the Northern Pacific simple Pacific engines was possible on account of the better balance. An increase in sustained horse power at high speeds without modification of the boiler is also possible. The builders state that from tests made on the New York Central's four cylinder balanced compound 4-4-2 engine, it was shown that with indentially the same size of boiler the compound engines developed from 20 to 30 per cent. greater horse power at high speed than the original simple engine. In actual service the compound engine developed 1,688 indicated horse power at 67 miles

some of the advantages claimed for it are that with the combustion chamber the ends of the flues being removed from the hottest part of the fire, a great reduction in flue leakage is effected, also that the combustion chamber gives ample room to work on the flues without removing the brick arch. The combustion chamber increases the heating surface of the fire box and though it reduces the tube heating surface. It is said to steam as well as a similar engine without the combustion chamber and greater tube heating surface. We are informed that a thorough trial of the combustion chamber on the Northern Pacific has demonstrated the fact that where water conditions are bad it reduces boiler repairs.

The weight of this engine in working order is 240,000 lbs., and that of the engine and tender together is 380,500 lbs. The rigid wheel base is 12 ft., that of the whole engine is 33 ft. 5 ins., and that of the engine and tender is 62 ft. 10 ins.

Piston—Rod diameter, 3¼ ins.; piston packing, 2 C. I. snap rings.

Valves—Type, piston, travel, 6 ins.; steam lap, 1 in.; exhaust clearance, high pressure, 5/16 in.; low pressure, ¼ in.; setting, ¼ in. lead full front and back.

The H. W. Johns-Manville Co., of New York, are now placing upon the market and installing sectional tile pipe conduit, which provides a covering for pipes running underground. This is known as the "J-M" Portland Sectional Conduit, and consists of tile pipe made in top and bottom sections. The division being made by cutting half through the shell of the pipe before it is baked, and then breaking afterwards, so that the joint is very much like that made in replacing pieces of a broken plate, the use of hydraulic cement makes it possible to put these sections together when desired. The top and bottom sections are numbered to correspond, so that the same sections can always be mated.

### Hydrostatics in the Shop.

It is a well known law in physics that the pressure of a liquid on the bottom of a vessel, due to the weight of the liquid, is independent of the shape of the vessel, and is also independent of the quantity of liquid which it contains. The pressure on the bottom of the vessel depends on the area upon which the pressure is exerted, and its depth below the surface of the liquid. This principle has been called the hydrostatic paradox because the same pressure may be obtained by using different quantities of the same liquid.

As an example of this hydrostatic paradox, take an ordinary funnel, such as is used to fill an oil can cork the small end of the funnel, and fill it full of oil, the pressure on the cork will be equal to the weight of a column of the oil with a cross section equal to the area of the end of the cork, and as high as the surface of the oil is above the cork. Now suppose you tie a piece of canvas or leather over the wide bell mouth of the funnel, so that oil will not leak out, and turn the funnel upside down, you will have as much pressure on the leather as if you had a cylindrical pot, with a bottom equal in area to that of the leather, and the pot filled to a depth equal to the height of the oil in the inverted spout of the funnel.

Pascal, the great French mathematician, in 1647 performed an experiment which proved this curious fact concerning pressures caused by liquids. He took a strong cask and filled it with water. In-

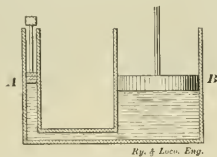

OUTLINE OF THE HYDRAULIC PRESS

to the upper head of the cask he tightly fitted a tube of small diameter and about 34 ft. long. On filling this slender tube with a comparatively small quantity of water he succeeded in bursting the cask open near the bottom. In this case the pressure exerted on the bottom and laterally was the same as if the 34 ft. tube had been of the same diameter as the cask.

The fact that the pressure of a column of water is exerted on the sides of a vessel, proportional to the height of the water above the point pressed upon, may be seen by looking at an ordinary railroad water tank and observing that the bands which surround the staves are closer together at the bottom than they are at the top. The principle of fluid pressure being exerted in all directions when confined, is made use of in various ways but one conspicuous example

may be seen in any railroad shop by those who take time to examine an ordinary wheel press. This machine is nothing more than a powerful hydraulic press applied to the special work of putting wheels on axles or in taking them off.

Consider, for example, the 600-ton wheel press made by the Niles-Bement-Pond Co., which we illustrated and described on page 483 of our October issue. One of these presses may be seen in

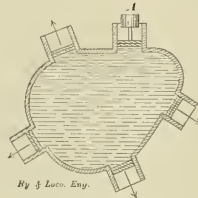

FLUID PRESSURE ACTS IN ALL DIRECTIONS

the Meadville shops of the Eric Railroad. The ram is 17 ins. in diameter and has a travel of 42 ins. There are three pumps which force water into the chamber containing the ram, and one of these has a diameter of 1 in., another is  $1\frac{1}{4}$  ins. in diameter, and the largest is  $1\frac{3}{4}$  ins. in diameter. All have a stroke of  $4\frac{1}{4}$  ins. The total area of the three pump plungers is 4.417 sq. ins., while that of the ram is 227 sq. ins. The ram has therefore more than 51 times the surface of the combined area of the three pumps. If the three pumps, working together, each developed a pressure of 5 lbs. per sq. in., there would be something above 255 lbs. pressure on the end of the ram. When only the smallest pump is used, as it may be for the final placing of a wheel when slow movement of the ram is required, the pressure developed by the 1 in. pump is multiplied 289 times, so that if it should develop a pressure of 4,000 lbs. it would, in one stroke, force into the large chamber a quantity of water which would spread out over the base of the ram, into a film not much thicker than a sheet of stiff paper, but the ram, if we neglect its own friction, will then be found to push with a force of more than a million pounds, while advancing through the minute space of about one-seventieth of an inch.

### Proposed Railway in Spain.

A dispatch from Bilbao, Spain, states that a board of engineers is engaged in the consideration of a scheme for the construction of a railway connecting Ferrol with Santander via Aviles and Pravia, and linking Santander with Bilbao and San Sebastian, and finally terminating at Hendaye, on the frontier. The Spanish Government has promised support to the scheme. The line will traverse a rich mineral district that has hitherto been little worked.

### Temporary Frame Patch.

A very good patch for a broken locomotive frame was recently brought under our notice. The frame was on a ten-wheel engine where provision is made for the fire box to come out flush with the outside of the frame and to slope forward. The break was in the top bar, clear through, and was at a point where the frame had been welded in the making, and through an old bolt hole.

The method of patching consisted in bolting a pair of flat plates, one on each side, on the outside of the frame. The patches came flush with edges of the frame bars, though our illustration, in order to indicate the outline of patch, shows it as just inside all round. These flat patches were secured by six horizontal bolts.

The space between the top and bottom frame bars was occupied by a U-shaped piece of wrought iron, closely fitted. This was secured to the lower frame bar by three bolts, and to the pedestal jaw by a countersunk headed bolt, as shown in our illustration. The top of the upper frame bar had a piece of wrought iron fitted to its sloping contour, and the bolt next the pedestal passed through the frame and was tapped into the U-shaped piece, where it fitted round under the lower edge of the upper frame bar. The piece was stepped down on its upper side, and a couple of bolts were passed through the frame in the spaces between the

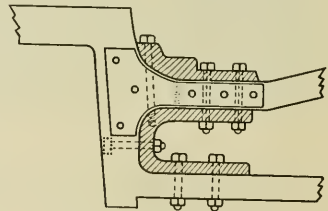

TEMPORARY FRAME PATCH

three horizontal bolts. The whole patch was found to be very serviceable, although the boring of the holes weakened the frame. It was quickly and neatly done, and constituted a temporary repair which lasted until the engine had to go to shop. The upper edge of the side patch on the outside had to be beveled in order to facilitate the caulking of the mud ring corner.

The General Electric Company, in common with many other large manufacturing concerns, is announcing a general advance in prices of electrical apparatus and supplies. This will not unlikely be followed by further advances if present market conditions continue, and no immediate change is predicted.

# General Correspondence.

## Hose Gaskets.

Editor:

That a thing of beauty is not always a joy forever is well illustrated by the brands "Sublime," "Gladhand," and "Ridiculous," in the hose gasket world. The first is short of the fluid extract of gum caoutchouc, lacks correct measurement, and bears a delicate but false impression of a trade-mark, while the second resembles the real thing in gauging, but has cold shivers, or that tired feeling after a few months, and breaks down in attempting to apply them, while the latter among some is of such bold proportion as to win favor by the generosity of stock. Now the hose gasket is an innocent looking little article. It's value begins at the coal pile, and the coal pile is an item of expense, you know! From heat energy generated at the locomotive firebox there is developed a colorless gas in the steam dome which keeps the air compressor alive; and the air pump is an item of expense, you know! Steam, too, is supposed or intended to supply necessary warmth for interior heating of cars, not the outside of them, as the gasket ofttimes infers.

From the air compressor the agency known as compressed air is intended to perform a vital function that must exert its influence in retarding or stopping at least seventy-five per cent. of the movement of cars in a train on the road. To have this power brought to its best use, train line leaks should be nominal. In mechanics, if a piece of metal of specified dimension is found of insufficient strength the weakness is overcome by substitution of a metal that will stand the strain. But the poor hose gasket has been for years and is yet an instrument of such insignificance that any old thing seems to apply in purchasing them. Thousands of dollars have been expended by railways in renewals of damaged hose couplings, due to pounding them to make tight a joint.

So much for the sermon! Now generalize: Why not insist on a gasket that is standard in gauging and quality? The machining of couplings, especially air and signal, have been a standard for years. There is no such thing as one thirty-second of an inch difference in grooving. The quality of a hose gasket should be such that deterioration should not impoverish its flexibility in six or even twelve months. The manufacturers of air and steam apparatus without question know through the efforts of years experience

of their efficient inspectors just what the requirement should be along these lines and the cheapest, little big thing in line of purchase by railways is to insist that to be genuine specifications must be within the manufacturers' requirement, thus indirectly holding manufacturers of air brake and steam heating apparatus strictly responsible for standards of quality and measurement.

W. H. D.

Concord, N. H.

## This Is All Right.

Editor:

A great deal has been said and numerous write-ups have appeared on the

pencil sketch showing plans and dimensions of my new 60-car capacity freight car repair yard at Eldon, Mo., together with four cuts showing the manner in which we handle wheels, heavy materials, scrap, etc. You will note by the sketch that this yard is composed of two parallel tracks, 20 ft. centers, 30 cars capacity each. Between these two tracks, running full length, is a 20 in. gauge track of 30 lbs. to the yard iron rail. Wheels of truck are 8 ins. in diameter. Hung underneath the axles, coming up to the level with top of rail, is a channel iron spring plank out of an old car-truck, with the flange turned up. This makes an ex-



CAR REPAIR TRACKS WITH 20-INCH TRACK FOR DOLLY TRUCK

subject of strengthening our cars to keep in step with the increasing size of our locomotive power, and many improvements have been made in the last few years, but while doing this, it is apparent that the facilities for doing with have been seriously neglected. In visiting the many freight car repair yards throughout the country, in most cases you find them handling the repairs to cars in the same old way that they were doing years ago; and you may see many new terminals with the construction of the repair tracks the same as they were years ago.

Some two years ago this important subject began to appeal to me; consequently I have given the matter of construction of, and handling of materials on, repair tracks serious consideration, and am submitting to you herewith a

cellent truck for handling wheels to and from any point in the yard.

This yard is surfaced to the top of the rail between the tracks; also an 8 ft. shoulder on the outside of the tracks with gravel, making the entire yard level. Between the rails of each track the filling only comes up to the top of the ties. The dotted lines in the sketch show air line underground, with the hose connection every 30 ft. This air line furnishes air to operate a crane located in the center between the four wheel tracks, which is used to load and unload wheels and other heavy materials. Air pressure is used for testing of brakes and operating air motors for boring; also an air hammer that is used in repairing steel cars.

Illustration Fig. 1 shows a laborer handling dolly truck loaded with jacks

and tools, preparatory to changing a pair of wheels from under a car. The laborer delivers tools to a truckman and his helper. Then, with the assistance of another laborer (we work two on this repair track), he goes after a

any further details be desired, by addressing me, I will be glad to answer any questions that may be asked.

C. E. Gossett,  
Master Mechanic.

Eldon, Mo.

stationary engine with its drivers off the ground. In this case a driver is a lever of the third class. The axle is the fulcrum, the tire is the weight and the crank pin is the power. We all know that in a lever of the third class the

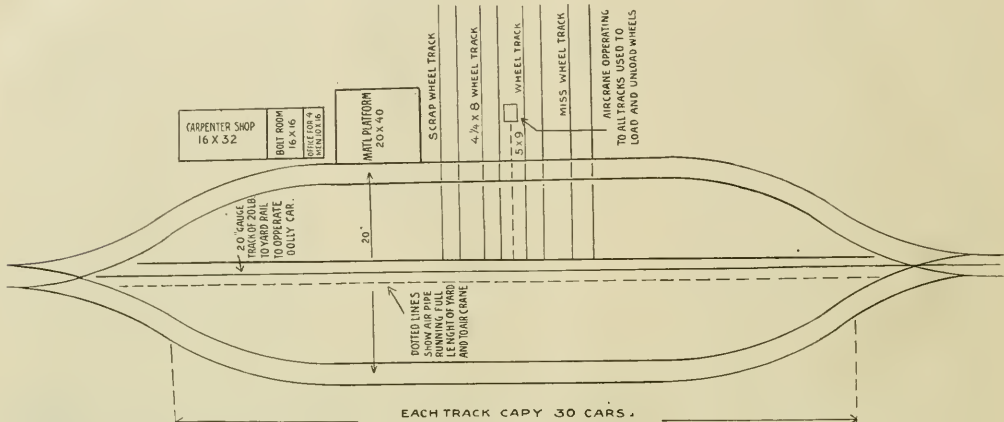

PLAN OF CAR REPAIR TRACK AS LAID OUT AT ELDON, MO., ON THE ROCK ISLAND LINES

pair of new wheels, using the dolly truck as shown in Fig. 2. After the new wheels are delivered to a point where they are to be applied, the second hand pair of wheels which have been removed from the car are loaded on the dolly truck and eventually stored on the scrap wheel track. Fig. 3 shows

**Slip of Driving Wheels.**  
*Editor:*  
I have been very much interested by the articles in regard to wheel slipping which you have published during the last few months. I think that Mr. Reardon's explanation of a driver's slipping is correct. But when he says that the

nearer the power is to the weight the greater force it will exert. If we increase the diameter of the drivers the power is further away from the weight and the engine is not so powerful, and therefore not so liable to slip.

With an engine on a track the case is altogether different. The axle is no longer the center of rotation, but is replaced by the point where the wheel touches the rail. This point is called the "instantaneous center." This was fully described in RAILWAY AND LOCOMOTIVE ENGINEERING, July, 1906, page 310. The point of contact between wheel and rail is the fulcrum, and the crank pin is the weight. The pressure against the front cylinder head forces the frame forward and pulls on the axle, and the pressure on the piston forces back on the crank pin or weight. The power exerted at the axle, or the power, and the power exerted at the crank pin, or weight, are the same; but as the distance from the power to the fulcrum is greater than the distance from the weight to the fulcrum, the power at the axle has the greater leverage and overcomes the power at the crank pin, the engine moves forward. If the wheel is made larger, the weight is proportional nearer the power, and so the locomotive can develop less power and therefore is less likely to slip. In the last case there are a few minor forces, but these are not large enough to be taken into consideration. In the two preceding cases the crank is supposed to be on the lower half and the engine moving ahead.

W. M. DE WITT.



FIG. 1. DOLLY TRUCK LOADED WITH JACKS

the dolly truck with a body applied to it and the two laborers starting out to clean up scrap about one hour before the day's work is done. I would respectfully invite the attention of your readers to this plan of operating a running repair freight car yard, and should

statement, "The resistance to slipping increases directly with the increase in diameter of drivers," made by "Technology," is incorrect, I do not agree with him. I will try to prove that the statement is correct.

We will first take a locomotive as a

Vernon, N. Y.

**Slipping of Locomotives.**

*Editor:*

In the October number of RAILWAY AND LOCOMOTIVE ENGINEERING Mr. T. H. Reardon takes exception to a statement made by me in your June number in regard to the slipping of locomotives. I feel confident that his criticism is based on a misunderstanding of my meaning, and lest others should fall into the same error, I should like to explain myself through the columns of your valuable publication. In the June number I make the statement that large drivers have a greater resistance to slipping than small ones. Mr. Reardon, and perhaps others, appear to assume that I mean, that large wheels have a greater area in contact with the rails than small wheels, and that the friction is thereby increased.

The first law of friction, as commonly stated, is that the friction depends upon the pressure between the surfaces in contact and upon the nature of those surfaces, but is independent of the area of contact. This Mr. Reardon quotes, and far be it from me to dispute it. When he talks about the area of contact between the wheel and the rail, he is getting down to a very uncertain quantity and one that cannot be measured with any degree of accuracy. This fact, together with the statement that the areas in contact are not a factor in the friction, make it a waste of time for us to speculate on the actual area of contact, or whether a wheel of twice

same for a locomotive with 3 ft. wheels as for one with 6 ft. wheels. Now, when a locomotive driver slips, we no longer have the condition of rolling contact, but the wheel revolves about

length of cranks, the pressure behind the pistons would have to be twice as much with the large wheels to cause slipping. On the other hand, the tractive force would be only half as much

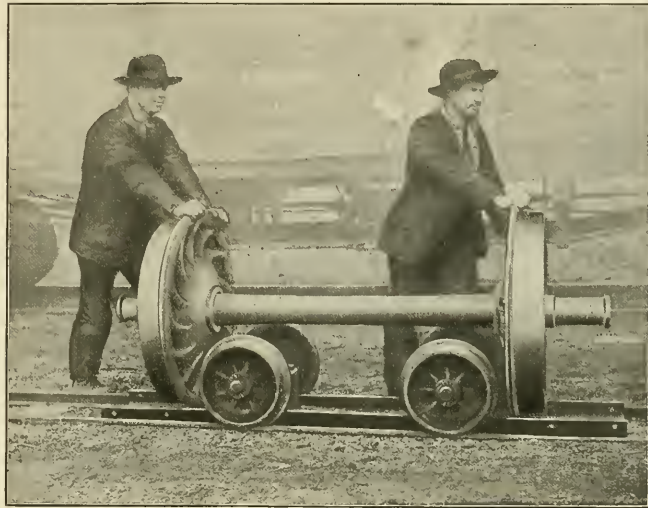

FIG 2. DOLLY TRUCK TRANSPORTING WHEELS

its axle, as is the case with a stationary engine. In the case of the 3 ft. wheel we have the force of friction acting at the circumference, that is, with a lever-

age being that, with equal steam pressures, cut-offs, and cranks, the foot-pounds of work done per revolution would be the same in each case, but with the large wheels the work would be done through twice the distance that it would in the case of the small wheels. Therefore the pull in pounds would be only half as much with the large wheels. However, the power of a locomotive is usually limited by slipping, and not by boiler pressure, so we could admit twice as much pressure behind the pistons of the large wheeled engine without slipping her. This would bring her tractive force up to that of the small wheeled engine again, but she would pull her load twice as far for one revolution as would the other.

Mr. Reardon goes on to say that the value of the crank leverage in the eighth position is .7071 of its full value, and when one crank is on the eighth the other is on the three-eighths position, so that the combined leverage is 1.414 times as much as when one crank is on the quarter and the other is on the center. This is true, but the turning effort is made up of two factors, leverage and one which has been apparently lost sight of, viz., pressure. For the crank on the eighth the pressure is usually a maximum, but for the crank on the three-eighths position the pressure is dropping very rapidly, for the cut-off almost always occurs pre-



FIG 3. TRANSFORMED INTO A TRAVELING SCRAP RECEPTACLE

the diameter would have twice the area of contact. Therefore, with a clean, dry rail in each case and the same weight on the drivers, it is fair to assume that the friction would be the

age of 1½ ft., while in the case of the 6 ft. wheel we have the same force of friction, but acting with a leverage of 3 ft.

This means that, with the same

vious to this crank position, so this crank cannot have a very great effect in producing rotation. Thus we cannot say the rotative effect is 1.414 times what it is when one crank is on the quarter and the other is on the center, although it is doubtless somewhat greater, for slipping actually does occur more frequently at the eighth position than at the quarter.

The fact of reduced piston area on which steam may act, when the rod is in tension, may explain why slipping occurs on the lower eighth for some engines, but it does not explain it for engines equipped with tail-rods, where the areas on each side of the piston are equal, and they are as apt to slip in this position as other locomotives.

"TECHNOLOGY."

Boston, Mass.

### Why Fillets Add Strength.

Editor:

It is well known to those who are familiar with iron castings that a sharp inside corner is a source of weakness and consequently we never find an inside corner terminating in a sharp angle. It is always rounded out by a fillet which gives the casting greater strength. The additional strength, however, is not due to the extra amount of metal that goes into the casting but to the internal structure of the metal which is caused by the rounded surface of the fillet.

When a casting cools the iron crystals arrange themselves perpendicularly to the surface of the metal. In Figs. 1 and 2 the dotted lines represent the formation of the crystals. Fig. 1 is a section of a casting without a fillet. The line

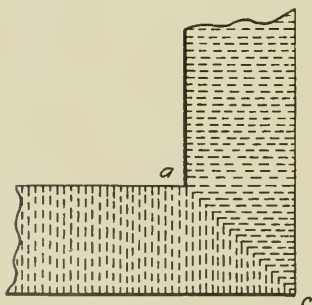

FIG. 1. CASTING WITHOUT FILLET

ac from the inside angle to the outside angle is a source of weakness because the particles of metal, by mutual interference with one another, form a series of angles along this line which is contrary to their arrangement in the body of the casting. This abnormal formation weakens the adhering power of the metal particles with the result that the casting is weakened.

The second drawing, is a section of a casting in which a fillet has been used. The rounded surface at *b* permits the crystals to form perpendicularly to the surface of the casting at that point, and this formation extends down into the metal for a considerable depth, as shown in Fig. 2. It will be seen that the interior structure in the vicinity of *b* is almost homogeneous with that part of the casting which is bounded by flat sur-

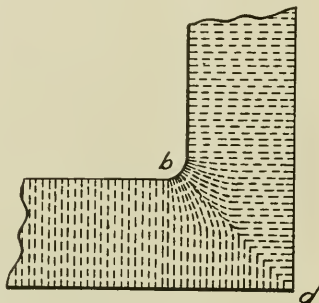

FIG. 2 ARRANGEMENT OF PARTICLES WHEN FILLET IS USED

faces and that the natural formation of the crystals has not been interfered with to any great extent. It is due to this arrangement of particles that the angles of a casting in which fillets have been used have greater strength than those of a similar casting in which the fillets have been omitted.

E. C. LANDIS.

Nashville, Tenn.

### Filing Straight.

Editor:

We recall the appointment of a foreman in a locomotive repair shop, and in the inevitable criticism that followed, an old hand sententiously remarked that the new foreman could not file straight. It did not occur to the speaker that the faculty of making others file straight is much more important in a foreman than the possession of the faculty himself. It is a high accomplishment in any machinist, and is not less important because of the increase of planers and shapers and millers and other machines that are doing work with a degree of perfection that could not be rivaled by the most skilled artisan.

Filing straight is the "hall mark" of the master machinist. Simple as it may seem, it is, like the beautiful in art, difficult of accomplishment. It consists chiefly in the proper holding of the file and the application of the varying pressure during the stroke. The perfect work on a flat surface is got by moving the file in a perfect plane. In a large surface the difficulty is not so great. In smaller work that may be grasped in the vise, the tendency on the part of the inexperienced is to lower the hand

on the side where the longest part of the file happens to be, causing a rounding of the outer edges of the surface operated upon. The varying leverage incident to the motion of the file accounts for this, and must be met by the varying degree of pressure alluded to. When this manipulation of the file becomes crystallized into instinct, then, and then only, the machinist can file straight.

The beginner should observe that the ball of the file handle should rest in the center of the hollow of the right hand, the point of the file being held firmly between the thumb and fingers of the left hand, the weight being applied more by the thumb than by the fingers. The best positions will come naturally after continued practice, and it may be remarked that in the case of a new file the application should not be too vigorous. The teeth of the file are more readily broken off when sharp and new than when slightly used. The best practice is to begin a new file on brass or bronze work, for the reason that these metals require that the files should be sharp to penetrate the ductile surface. A file that has been used on brass for some time will be found to continue to be good enough for wrought or cast iron. It is well to avoid touching the filed surface with the hands or with waste or other damp substances, as several strokes are lost in penetrating the surface interfered with.

OBSERVER.

### Crosshead Puller.

Editor:

The accompanying sketch is a device for moving the crosshead in the guides of our engines during the process of running repairs; this device comes in handy at such times when the crosshead is in such a position that it is impossible to get a leverage on it with a

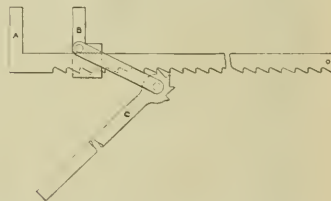

DEVICE FOR PULLING CROSSHEADS

bar. The end of the rack *A* is placed against the back guide block, if it is desired to move the crosshead ahead, and the movable portion *B* is placed against the crosshead; the lever *C* is then engaged in the rack and moved forward, which also carries the crosshead; if necessary, make the second adjustment, or until the crosshead is in the desired position. The rack *A* is 34 ins. long and the handle *C*, 24 ins. This



kink is in use at the West Oakland roundhouse, and is found to be quite useful.

W. UPDEGRAFF.

West Oakland, Cal.

#### Once It Was It.

Editor:

This is an old time Central Pacific engine, 1013, which no doubt has seen better days, and during its time was probably the climax of locomotive construction.

W. UPDEGRAFF.

Oakland, Cal.

#### Exploded Boiler.

Editor:

I noticed in your issue two months ago a picture of a boiler explosion, and I am taking the liberty of sending you a picture of all that is left of an explosion which occurred on this road the 16th of this month—engine No. 173, of the El Paso South Western Railroad, about four miles north of Alamogordo, N. M. The fireman was killed outright, and the engineer and brakeman died during the day. The boiler was blown over one hundred feet away and literally torn to pieces; nothing can be saved about it. The engineer and brakeman were blown about sixty feet from engine, and the fireman was blown into the tank and covered with coal. Trusting that you can use the photo.

X. Y. Z.

Alamogordo, N. M.

top edge of the cave trough, and when he got going at full speed he wrote down all he could think about what it would have looked like if it had been entirely different, and he tried the result on a news gathering agency. They liked the decimal at the end of the ten inches, and printed the thing as a story. Then somebody measured the building and found that the good judgment man was wrong by fully 90 ft., to say nothing of the 10 ins. and the decimal which had made the story so attractive.

The man went back to his native village after this, for a "well earned" vacation, and swelled round as one who had become a metropolitan journalist, and he received great consideration at the hands of the villagers. Now, gentle reader, if you think this is gulling the public on the wholesale plan, remember that this man, while he was wrong in nearly all his "facts," at least had a building to work on.

Not so very long ago, one of the daily papers here printed an account of how a poor fireman had been paid an enormous amount of money by a large corporation for his patent rights on a

as attractive as the good judgment man's decimal figures. If anybody was looking for the truth about any of these things, the "stories" didn't give him any, that is all.

Moral: Several figures in a decimal fraction, or a big sum of money, look



OLD TIME CENT. PAC. WITH FIRE PUMP AND HOSE REEL

equally well in print. The principal ingredients for a lot of good railroad stories in the daily press are plenty of ink, a good pen, and a number of sheets of paper. A bit of blotting paper and some truth are not much use in getting the stuff out. When writing them it is advisable not to use mere ink. Take writing fluid; you can make more decimals with it.

#### Block Signal Equipment.

The finishing touches are soon to be put on the Block Signal Equipment of the Harriman Associated Lines. There are now about 3,300 miles of road already equipped and 1,500 miles more are now covered by contract recently let by Mr. J. Kruttschnitt, director of maintenance and operation of the system. Speaking of the block system, Mr. Kruttschnitt said, "It is impossible to protect a railroad from collisions without having block signals. On a road equipped with such signals, collisions cannot occur if railroad employees obey orders." This last sentence contains the gist of the whole matter. The adoption of the block system anywhere carries with it the necessity for the loyal obedience to the indications and the enforcement of the discipline necessary to attain it.

It is expected that by the end of this year the main lines from Omaha to Chicago and from Los Angeles to San Francisco will be protected throughout by block signals of the latest and most approved type.

Don't tell what you are going to do—do it!

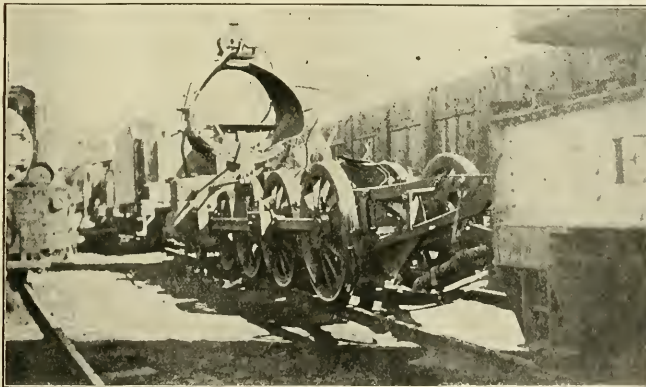

REMAINS OF ENGINE AFTER BOILER EXPLODED

#### Small Fractions and Big Money.

BY A. O. BROOKSIDE.

Some time ago a man who flattered himself that he had good judgment left his native village and came to New York. He looked at the skyscrapers and other things in the metropolis, and picked out one of the tall buildings and began to exercise his good judgment. He said the building was 372 ft. 10.437 ins. high from the ground floor to the

wonderful motor. On inquiry at the office of the large corporation, it developed that they did not know of the fireman, were not on the hunt for a motor of the wonderful description, and had not paid away even two nickels in the twilight, let alone nearly a million dollars in the dark. The "large sum of money" contrasted nicely with the "poor fireman" in the story, and when they were side by side they were nearly

### Electro-Magnetism.

BY ROGER ATKINSON.

The term "electro-magnetism" is used to express the production of magnetism or "magnetic field" as the region affected is called, by the power of an electric current flowing in a wire or conductor of any kind. The fact that

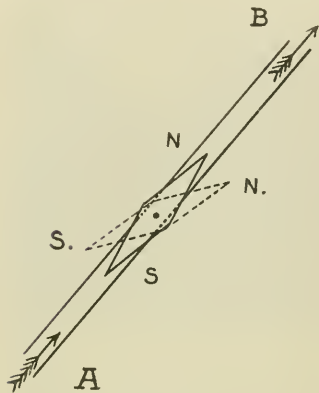

FIG 1

an electric current flowing in a conductor always produces a magnetic condition in the atmosphere surrounding it, and conversely that such a magnetic field or condition can be made to reproduce a current in another wire or conductor, is the basis of all the immense development that has taken place in the use of electric power for all engineering purposes.

It is almost impossible to find any so-called electric device or machine which does not make use of this fact in some form or other. It is therefore absolutely necessary for anyone who desires to attain some knowledge or understanding of electric appliances to begin by acquiring a clear idea of the magnetic field which surrounds a single wire or conductor carrying a current.

The discovery, made by a Danish philosopher named Oersted, was that if a magnetic needle freely suspended on a point, an ordinary pocket compass will do, is brought near a wire, carrying a current, the needle is deflected from the position in which it is held by the magnetism of the earth, and it is always affected in a certain definite manner. The result of this simple experiment is best shown by assuming that the earth's magnetism is absent. Thus if *AB* is portion of a wire carrying a current flowing in the direction from *A* to *B*, as shown by the arrows, Fig. 1, and a suspended magnetic needle *NS* (of which *N* represents the North pole and *S* the South pole) is brought near it from above, the *N* pole will be deflected towards the right hand and

the *S* pole towards the left hand, as shown in position *N'S'*, Fig. 1.

If, however, the suspended magnetic needle be brought near the wire from below, the *N* pole will be deflected towards the left hand and the *S* pole towards the right hand. Fig. 2.

Now in order to simplify the matter and render it easy to remember, the general results attained are reduced to a theory, which is expressed as follows: The magnetic action of the current on the needle is assumed to act upon the *N* pole only. Then if we take the black circle *A*, Fig. 3, to represent the cross section of a wire carrying a current from the observer or down through the paper, the arrows *a* and *b* will represent the direction of movement of the *N* pole of the suspended magnet when brought near the wire from above or below, and if it be brought near from either side the movements of the *N* pole will be shown by arrows *c* and *d*.

It can be shown that this direction of movement is always tangential to the circle drawn at any given distance from the wire and always equal for the given distance. The deflection is greater or less as the needle approaches or recedes from the wire, and it has been proved that the directing force is inversely proportional to the distance from the wire, that is, the force is double at half the distance, three times at one-third the distance, etc., and vice versa, half at double the distance and so on.

If, therefore, we describe a circle of any radius about the wire we say that the magnetic force is constant at the circumference of that circle (so long as the current is constant), and if a circle be described at half the distance of the former one, the tangential force at its circumference will be double the force at the former circle. We may therefore illustrate the magnetic field about a wire by drawing a series of circles about the wire and further apart as they recede, in order to represent the difference in intensity of the magnetic force, and we also assume that the field has a rotative action in the direction of its action upon the *N* pole of a magnet, and we call it the rotating magnetic field, surrounding a wire carrying a current.

If the current is flowing in the opposite direction, that is, towards the observer, or up from the paper, the cross section of the wire is usually shown open in such a case, and it will be easily seen that the apparent direction of rotation of the field will be reversed as shown. In a few words the rotation is "clockwise" when the current is flowing from the observer, and "counter clockwise" when it flows towards him. As an interesting observation, take an ordinary pocket compass, such as is sometimes carried as an ornament on

a watch chain, select a street car rail which lies approximately north and south, so as to partly evade the action of the earth's magnetism on the needle, and place the compass on the rail, then if the *N* pole deflects towards the *E* or the right hand, the current in the rail is moving from *S* to *N*, or from the observer facing north, and if the *N* pole of the needle moves *W* or to the left hand, the current in the rail is moving from *N* to *S*, or towards the observer facing *N*. The pivoted magnet therefore can be used to detect the presence and direction of a current flowing in any wire or conductor.

### Liquid Air Claims.

When any improvement has been made on the steam engine, nearly all the inventors of the same or their friends have attempted to have it applied to a locomotive, the last place in the world for experimenting with a new and strange device. The same species of sentiment moved the people who were interested in the production of liquid air a few years ago to urge its use as a motive power for automobiles. Some experiments were made with liquid air as a medium for operating engines, but they were ridiculous failures and had much to do with arousing a prejudice against liquid air, which is not entirely dispelled. There were also many shady transactions among rogues

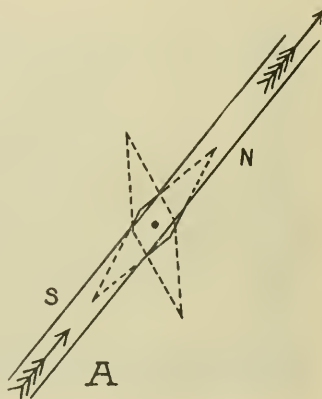

FIG 2

who established liquid air companies which have left behind an evil impression.

There appears to be a revival of agitation in favor of liquid air, reports being circulated from England that a man named Knudsen has invented a process for making liquid air which will reduce the cost to one-sixth of that involved in existing processes. As usual, the automobilist, who is successor to the locomotive owners, is looked upon as the

victim who can pay for pushing the latest liquid air enterprise into popularity. British commercial and engineering journals are discussing this new claim for the use of liquid air, and the positions taken are significant of the predilections of the two classes of journals. The commercial people perceive a new money-making business; the engineering papers practically say, humbug.

A well-known mechanical engineer, writing to Engineering, says:

"The drivers of automobiles, then, are invited to buy liquid air at a price which is 1,200 times as great as that of a quantity of steam of equivalent power. Remembering that liquid air is only half as powerful as steam, and that it is impossible to mount the most economical engines on automobiles, we see that each horse power hour would want at least 30 lbs. of liquid air. A 10 h.p. carriage, therefore, would require for a 10 hour spin 3,000 lbs. of liquid air to drive the engine. But it is impossible to keep this material without a quantity constantly boiling away; so that it would be necessary to begin the run with a supply about half as great again as is theoretically required—say 4,500 lbs.—two tons of the motive liquid, at a cost of £112 (about \$543). The tank to store this must have a capacity of 72 cu. ft.; and as a thick insulation of at least six inches would be required to check the boiling off as much as possible, the external dimensions of the

which must itself be first produced by the expenditure of an infinitely greater amount of power than that fluid possesses." Apparently the uses of liquid air in the production of oxygen and in preparation of an explosive for use in blasting seem to be the only ones that bid fair so far to achieve any measure of commercial success.

**Electricity Versus Steam.**

A largely attended meeting of the Western Railway Club was held at the

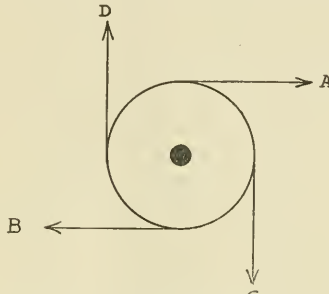

FIG 3. MAGNETIC ACTION ABOUT A WIRE

Auditorium Hotel, Chicago, last month, President H. T. Bentley in the chair. The feature of the evening was the reading of a paper by Mr. E. W. Farnham on the subject of Electrical Power versus Steam Power in the operation of Railroads. Mr. Farnham's paper was illustrated with a series of stereopticon views, and the various methods of applying electric power was very fully described. The speaker's array of figures and illustrations showed a perceptible percentage in favor of the electric motor in city and suburban traffic. The deductions as to the use of electricity were strongly in favor of the inverted protected third rail system with under-running collector shoe. The system showed that it affords protection against personal injury through accidental contact with the energized rail, and absolute protection against any and all weather interferences, such as snow, sleet, rain or high winds, thereby eliminating interruption to traffic.

Mr. C. F. Street, C. E., ably discussed Mr. Farnham's paper, and seemed to voice the opinion of the majority present in stating that,

"After some of our heavy suburban traffic has been successfully handled by electricity and extensions have been made to portions of main lines, we will know more about what it can do with through service, but I do not believe that any one is at the present time in a position to say definitely that electricity can be employed to better advantage than steam for operating all

trains or runs such as that from New York to Chicago, or Chicago to San Francisco. This is the sort of thing we must work up to gradually. Mr. Farnham has stated many things about the weak points of the steam locomotive, the overhead trolley and the third rail, and would have us believe that his under-running third rail is the panacea for all the ills which appear in connection with them. In spite of his statements, however, the steam locomotive seems to be pounding along and making a pretty good record, and will continue to do so for many years to come, and quite a few new locomotives are being built."

The unanimous thanks of the Club was tendered to Mr. Farnham for his paper.

**London's Tubes.**

There are five deep level underground railways in London and two which are comparatively near the surface. These two are the Metropolitan Railway and the Metropolitan District Railway. The deep level tubes are the City and South London, the Waterloo and City, the Great Northern and City, the Central London, known as the Two-Penny Tube, and the Baker Street and Waterloo, commonly called the "Bakerloo." Three other lines are under construction, and four new ones have been authorized. Last year the existing tube railways, together with the Metropolitan and the District, which are spoken of as shallow surface railways,

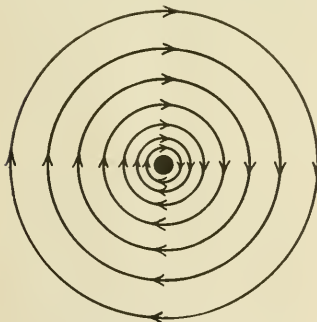

CURRENT FLOWING FROM THE OBSERVER DOWN INTO THE PAPER

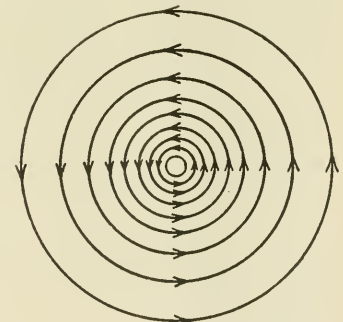

CURRENT FLOWING TOWARD THE OBSERVER, UP OUT OF THE PAPER

tank to be mounted on the automobile would be 7 ft. by 5 ft. by 4 ft. Perhaps, however, the design provides for putting it on a tender coupled on behind.

"It is remarkable what optimism has characterized the proceedings of liquid air companies in the past, and enabled them to build and maintain the highest hopes on an unbroken succession of disappointments and mistakes."

In the same issue K. S. Murray alludes to the proposal to use liquid air as a motive power as an attempt to use "a most troublesome and unstable fluid,

carried 258,000,000 persons, and it is expected when the new railways are completed that double that number of people will travel.

The Missouri Pacific management will establish a system of awarding premiums in the fall of each year for roadmasters and section foremen, based upon inspection of the best results attained on the tracks of the two lines, the Mo. Pac. and the Iron Mountain. —N. Y. Globe.

# Railway and Locomotive Engineering

A Practical Journal of Railway Motive Power and Rolling Stock.

Published Monthly by

ANGUS SINCLAIR CO.,

136 Liberty Street, New York.

Telephone, 984 Cortlandt.

Cable address, "Loceng," N. Y.  
"Glasgow," "Locauto."

## Business Department:

ANGUS SINCLAIR, President.  
FRED M. NELLIS, Vice-President.  
JAMES R. PATERSON, Sec'y and Treas.

## Editorial Department:

ANGUS SINCLAIR, Editor.  
GEO. S. HODGINS,  
JAMES KENNEDY, } Associate Editors.  
J. P. KELLY,

## Advertising Department:

Eastern Representative, S. I. CARPENTER, 170 Summer St., Boston, Mass.

## British Representative:

THE LOCOMOTIVE PUBLISHING CO., Ltd., Amen Corner, Paternoster Row, London, E. C.

## Glasgow Representative:

A. F. SINCLAIR, 15 Manor Road, Bellahouston, Glasgow.

## SUBSCRIPTION PRICE.

\$2.00 per year, \$1.00 for six months, postage paid in the United States, Canada and Mexico. For other parts of the world, \$2.50 or ten shillings. Other parts, 20 cents. Remit by Express Money Order, Draft, Post Office Order or Registered Letter. Mailing address can be changed as often as necessary—always give old and new address, and if you subscribe in a club, state who got it up. Please give prompt notice when your paper fails to reach you properly.

Entered at Post Office, New York, as Second-class mail matter.

Copyright by Angus Sinclair Co., 1906.

For Sale by Newsdealers Everywhere.

## Observations on Electrical Traction.

The electrification of various lines, or more correctly, parts of railway lines, in the United States makes the remarks of two prominent railroad men, one in Great Britain and one in this country, of especial interest at this time. Mr. J. A. F. Aspinall, general manager of the Lancashire & Yorkshire, spoke on the subject at the last meeting of the International Railway Congress, and Mr. W. J. Wilgus, vice-president of the New York Central, spoke of the electrical work of his company at one of last season's meetings of the New York Railroad Club.

In speaking of the electrification of the Liverpool & Southport Railway, which is one of the L. & Y. Lines, Mr. Aspinall admitted that the change had been made, not with any idea of economy of working, but of securing better results. He said his company did not expect to save money, they expected to make money, and these, he considered, were very different things. Certain expenses more or less offset one another, but experience had shown that it cost more money to work the line by electricity than it had when locomotives were used.

Among the advantages gained by

electrical operation was the better use which could be made of terminal facilities during rush hours. As an example of this he instanced what he called the platform operations required for steam trains and for those electrically driven, when entering or leaving a terminus. With steam trains, the first platform operation consisted in the train coming in. The second was the following in of the locomotive which was to take out the train. The third was the departure of the train, and the fourth was the backing out of the locomotive which had brought the train in. These four platform operations required eight signal operations. The same train if handled electrically would require only two platform operations, and four signal operations. The train comes in, that is one operation, the motorman then goes to the other end of the train and takes it out, that is the second operation.

Not only was the terminal of the Liverpool & Southport used to greater advantage by the employment of electric traction, but a very important gain was made by the very possession of the facility to handle traffic; more traffic was offered. It would almost seem to be an axiom in railroad operation, that the more a line can do, the more it will be expected to do. This road had four tracks for a certain distance out of Liverpool, and when electrification first took place the business offered was such that it could be handled over two of these tracks and the other two were set apart for freight service with steam locomotives. The passenger travel, however, soon became so large that it necessitated the equipping of the two freight tracks with the third rail, and the use of them for passenger traffic in the rush hours. One might fairly apply Hamlet's words to the traveling public for it seemed, "as if increase of appetite had grown by what it fed on." In this way the greater cost per ton mile run, under the electrical system, was more than offset by the larger paying volumes of traffic which the road was able to handle.

The approximate figure which Mr. Aspinall gave for the electrification of such a line as the Liverpool & Southport was in the neighborhood of about £20,000 (\$97,000) per mile and which he believed was roughly about 3½ times that required for steam traction. Another interesting point brought out on that line was that the weight of what he called the locomotive equipment of the electric train was not any less than it would be with team locomotives. In main line work the total weight of motors, controllers and the electric equipment in general, about equals, if not exceeds, the weight of the ordinary train with the steam locomotive attached.

Mr. Wilgus, in his remarks in the discussion of Mr. B. G. Lamme's paper dealing with the electrification of a part of the New York Central, also had in mind the ability of the electrically equipped road, under certain circumstances, to attract passenger traffic and so to augment the company's receipts. This, it seems, is the *raison d'être*, for electrical equipment, and failing this, the alteration from steam to electricity would be probably a costly and useless experiment. In concluding his remarks he said: "It appears that, the purpose of a change of motive power for heavy railway service, from steam to electricity, is to abate the smoke nuisance and improve the passenger service so as to make travel more attractive. The electric system which is adopted, whether direct current or alternating current, must employ the safest appliances known to the art, it must have all possible safeguards against interruptions due to troubles in the power station and on the line, it must employ well-tried apparatus that has passed beyond the experimental stage, and it must be thoroughly flexible so as to afford the traveling public the advantages that are denied with steam operation. The use of any system which does not possess these qualities will burden the corporation adopting it with a heavy expense, for which there is no adequate return. Whether the system shall be alternating or direct current, depends entirely on the development of the art, from a practical standpoint and the local conditions. The more congested the traffic, the more necessary the adoption of the system that will be least in danger of failure and best adapted to public demands."

## Transportation and Advertising.

The Interstate Commerce Commission is a board which is required to perform important duties, mostly in the relations of the public to transportation companies. The authority of this board has been much more limited than we considered it ought to be, especially in supervising appliances and practice which affect the safety of travelers. We have before now advocated the endowing of the Interstate Commission with powers somewhat analogous to those of the Board of Trade in Great Britain, for the purpose of investigating the cause of railroad accidents, and of fearlessly placing the blame where it rightly belongs.

We have not changed our opinions in this matter, but we are constrained to raise our voice in protest against a ruling given by the Interstate Commerce Commission on a subject which we do not believe properly concerns them or their work. The ruling affects

the exchange of transportation for advertising space, and the Commission has affirmed that nothing but money must pass between a newspaper and a railway when adjusting such accounts.

This ruling has been given probably without consultation with the highest legal authorities in the land, and we hope and expect it will be upset by the Attorney-General of the United States, and we believe it will not be sustained by the courts, if the Commission should prove stubborn enough to have it go to the courts. Transportation is worth so much money per mile, and advertising space in a paper is worth so much money per inch, and it is a perfectly fair business transaction, taking the money value of each as a basis, to say that so much space is worth so much transportation, or so much transportation is worth just so much space.

The transfer of balances, not the actual passing of cash from hand to hand, is one of the recognized features of the vast mechanism of exchange which goes on all over the country. A railroad agent or a section foreman is given a free house, fire and light, by the company he serves, in addition to his pay, but the transaction is represented on the books of the company as worth so many dollars and cents, though no actual cash is paid out or comes in. There is no hardship to either party, and the whole proceeding is strictly honorable and is conducted on thoroughly business principles. If a physician attended the family of a carpenter who did some work in the doctor's house, would the adjustment of the accounts between them be otherwise than strictly correct if the doctor charged his regular fee for his visits and the carpenter charged up his labor and material at the ruling market price, and the two effected a settlement on that basis?

What is wanted in any case involving transportation and advertising space, between railroad and newspaper, is not a vexatious ruling based upon a wholly technical interpretation of the law, but the fair administration of the principle involved, for the purpose of securing honest observance on both sides, and with a view of facilitating, and not restricting, legitimate business.

An official of a railway passenger department, in closing an interview with the New York Commercial, says he believes "that the law requires not an exchange in kind, otherwise cash, as the Commission has held, but an exchange of equal value, and that is exactly what the giving of transportation for advertising amounts to. In other words, we could not lawfully, in balancing accounts, name a lower rate to the newspaper for the transportation it receives. It must be the same as is named in our

published tariffs, and the newspaper, per contra, must charge us its established rate for the advertising space we take."

#### Large Trains and Small Boats.

The melancholy accident which took place last month on the swing bridge over the Thoroughfare at Atlantic City has had the effect of directing public attention to the whole swing bridge question as applied to railroad transportation. Apart from the causes which led to the disaster, and which are mechanical and operating matters, there is a curious, and we might almost say distorted, view of marine rights taken all over the country wherever swing bridges on railroad lines are concerned.

We have seen railroad trains carrying perhaps five hundred persons bound for a big city stopped and compelled to stand still while a drawbridge ahead of the train was slowly opened for the accommodation of an oyster boat or an empty barge, manned by a few men probably not desirous of getting anywhere at any particular time. Here is practically a casual interruption to definite and important traffic, whose existence is not due to any haphazard arrangement and is probably extensively advertised so that all may know when and how it moves.

This kind of thing is the result of the operation of a law which was devised in the days when railroads were few and far between and before passenger traffic to and from large centers of population had grown to modern proportions. A sort of analogous performance may be witnessed in any large city where a heavily loaded dray crawls slowly up the street on the car tracks followed by a trolley, packed with people, the car compelled to go at a snail's pace.

The drayman has a right to the street, likewise the oyster boat and the barge have an undoubted right to the stream, but the regulation of traffic, which is not only within the power of government but well within the dictates of common sense ought now to be invoked and the law so altered that though individual rights may be preserved, the many may not have to suffer for the few.

At the present day practically the whole business of well nigh a city-full of people is to go to work in the morning and to go home at night, and they throng every highway and crowd every conveyance; yet while transportation facilities are taxed to the utmost, some small craft can halt a multitude if there is a swing bridge in sight to do it at.

The obstruction of important scheduled traffic in the rush hours in deference to this now outworn custom is like seeing the whole Philharmonic Society

stopped in the middle of the Halleluiah chorus so that some piccolo player on the rear seats of the orchestra may tie his shoestring and feel more comfortable.

We do not wish to see the rights of small craft on navigable streams or arms of the sea taken away or even seriously impaired, but we think that it is more in accord with twentieth century practice to deal with present day needs, and to regulate the times and occasions when swing bridges may be opened. Here is an opportunity for the modification of the law so as to meet in practical form the wants of a practical people.

#### Railway Clubs.

The Society of Railway Club Secretaries have brought prominently into notice the growing importance of the railway club. This is in keeping with the progressive spirit of the age, and differs from the spirit, which is happily disappearing, when every man engaged in research kept his own secrets or admitted others only as necessity demanded, the desire and aim not being to proclaim discoveries or improvements, but to use them only for personal ends.

It need hardly be stated that in the expanding realm of railway traffic there has been, and still remains, a mighty field in which mechanical ingenuity can exercise its skill. Not only in the special domain of mechanical appliances, but in all the multiform details that facilitate the work of the transportation department, there is a constantly widening sphere of action and a call for new methods.

The railway club gives an opportunity for the interchange of thought on these and kindred questions, and while it is true that periodical literature is rapidly taking the place of books and maintains a constant stream of information on every conceivable question, which can be readily reached by the humblest artisan, there is a peculiarly vitalizing influence to be felt in the opportunity of getting into touch with the results of experience direct from the lips of those who have passed through a course of training and who are actively engaged in the physical and intellectual activity incident to railway work. The advantages to the individual members may be briefly summarized as aiding, by mental exercise, in strengthening the faculties of the mind, in learning how seeming trouble can be overcome, how difficulties can be promptly met; while social intercourse with active, thoughtful men polishes the mind and engenders a kindlier courtesy in the relations of man to man.

These benefits have their correspond-

ing reflex on the community of which the members are a part. The good that is to be gathered from the meetings of the railway clubs tends to improve the conditions of life and work wherever the authority or example of the members extends. The latest improvements in mechanism and in methods are brought into the path of wider development. The public mind is better educated in regard to the growing benefits that come from a broader vision of the world of science, and thus the thoughts that are gathered at the railway clubs, like seeds sown in the furrowed earth, spring into full-blossomed utility.

#### Shortage of Freight Cars.

All through the fall of the year we hear a chorus of complaints from shippers in what may be called the grain regions of the country, regarding the shortage of cars. This trouble has not been confined to any one year or to times when a particularly plentiful harvest has been reaped. This year it has been estimated as a shortage of about 14,000 cars.

The usual reason given for the yearly car famine is that if railroads possessed the cars necessary to move all the grain offered, they would have an enormous rolling equipment idle on their hands during the greater part of the year, and that in order to do without this extra supply of cars, railroads permit themselves to be short during the grain rush. Many of the smaller roads have been accused of being under-equipped, and of resorting to the practice of buying few new cars and using those belonging to other roads. The per diem system was adopted and all roads were compelled to pay a daily rental, with the idea that the smaller roads would find it cheaper to own cars than to rent them, and we were told in effect that this system would almost automatically bring cars home again and that the annual shortage in the fall would be lessened, if not completely disappear.

Per diem has not produced very gratifying results in this direction if we are to judge from the outcry among the shippers in the West. They believe that the car shortage this year has been worse than ever, and it is plain that in practice the per diem system has not deterred many roads from using the cars belonging to others and paying for them, any more than a restaurant conducted on the European plan fails to secure patrons while men are hungry and have the price of a meal in their pockets.

A somewhat belated explanation of the car shortage has been offered. It is in brief that the farmers having garnered the golden grain desire to turn it into golden coin at the earliest pos-

sible moment, and that as practically all the grain raisers are playing the same game at the same time there is a good deal of crowding. All kinds of cars are used by the railroads to meet the demand, even gondolas have been pressed into the service, and the grain goes forward to the lake ports as fast as it can be moved. The result is that the lake terminals are congested, as grain comes in faster than elevators can store it or boats take it away and cars are simply held under load at the lake points until they can be emptied.

If this explanation is the correct one the car shortage is not the fault of small roads borrowing other people's cars, nor is it due to the inefficiency of per diem, nor to the want of vehicles to hold grain or to move it over the roads. The small neck of the bottle appears to be the transference of the grain from rail to water. The old time congested condition is in a measure recalled, which the fast freight lines, with their big lettered announcements of "No Transshipment," were once intended to relieve. The transfer of load is again the problem as it was in the days of old. Now is the time for the inventor of the grain dump cars or the car tipping device or the "underground elevators" to come to the front with something handsome.

Not long ago there was a meeting of those interested in the per diem charge, held at Chicago, and the lines owning 1,100,000 cars voted to increase the charge for detaining cars from 25 to 50 cents. This they call the "Car Hire Agreement" and it is supplemental to the per diem rules and independent of the American Railway Association but is to be carried out in harmony with the car service rules. Those who voted against it represented the ownership of 300,000 cars. Some of the Western roads wished to make the charge 75 cents, but the half dollar rate became the compromise figure. These lines believe that their shortage of cars was due to small roads holding back cars for an unreasonable time and the reason given above may have something to do with it.

Some people think that these regulations while they will be productive of some good will not cure the evil and a somewhat novel method has been proposed by a railroad man who has studied the question of car famine in the grain rush period each year. The idea he put forward was that all the cars in the country were to be made what he called "legal tender," that is that any empty freight car found anywhere could be appropriated and loaded. This means the pooling of freight cars, and it does away with home routing. By this plan there would not be much effort to get cars home again, as each road would

lay hold of and use any car in sight, without reference to where it came from or where it had to go.

The effect of this would be that all the cars on any road, loaded or empty, at a given time would for that day and date constitute that particular road's equipment, and the quickest way to make the entire lot available would be to empty them, fill them up with paying loads for anywhere, and get them moving again. Whether or not this scheme can or will be brought down to a workable basis remains to be seen. In the meantime the demurrage rate has been doubled and the general idea is to make those holding cars under load beyond a reasonable time put their hands down into their pockets and find a cash equivalent for the delay.

#### Value of Oil as Fuel.

Oil as fuel for locomotives was first tried in Russia and proved to be a success. When it came to be used in this country it was also found to be a highly efficient heat producer, and in point of theoretical excellence it is better than coal. Oil as fuel at the present time is very satisfactory, and has been made a success, but it is hard on the fire box plates, and the general wear and tear on a locomotive boiler burning crude oil is greater than that in which coal is used. Oil is cheaper than coal as fuel, and the balancing of the cheaper article, with somewhat heavier repairs, against the more expensive fuel and lighter repairs, is an operating detail which has to be worked out under the particular conditions which obtain on the road where crude oil has been substituted for coal.

The calorific value of coal, that is, its heat producing quality, is measured in what are called British thermal units. Such a unit is the amount of heat required to raise the temperature of one pound of pure water from 39 degrees to 40 degrees on the Fahrenheit thermometer. Theoretically, a pound of good coal, when properly burned, gives off about 14,500 B. T. U., but for practical purposes, and under average conditions and with varying qualities of fuel, perhaps the even 14,000 B. T. U. would be the more accurate figure. Crude oil, when properly burned, gives about 19,000 to 20,000 B. T. U. per pound. This places an advantage on the side of oil of about 5,000 B. T. U. Water evaporation per pound of coal is about 10 or 12 lbs., while from fuel oil it amounts to about from 13 to 14 lbs. This represents in round numbers about 25 per cent. more efficiency for oil as an evaporative agent, under the best conditions.

Oil weighs on the average about 7.90 to 8.25 lbs. to the gallon, and it has been estimated by those who use

fuel oil that about 163 gallons of oil equal about a ton of coal on the tender. In the matter of carrying fuel it may be said that from these figures it appears that about 1,316 lbs. of oil equal 2,000 lbs. of coal, which is a considerable saving in weight on the tank, and there is a saving of space due to the more compact form of the liquid. Drawing a rough and ready conclusion from these figures, it appears fair to say that simply as a heat producer oil is about 25 per cent. more efficient than coal, and that there is a large saving of weight carried on the tender and of space used.

#### The Milan Exhibition.

The show of locomotives and rolling stock at the International Exhibition at Milan, Italy, is a very fine collection. An elevated railway nearly a mile in length shows the complete signaling and other operations of European railways. A full size model of a portion of the great Simplon tunnel forms a striking part of the exhibition. The various constructional details are most skillfully imitated, and there are specimens of the iron arches used in the zone of highest pressure, 7,000 feet below the summit of the mountain. The strata of rocks are cleverly imitated in reinforced concrete. Even the hot and cold streams of water are reproduced.

The exhibits of locomotives are contained in two large sheds, each having twenty-four parallel tracks, with abundance of space between each track. The most attractive exhibit is that of two complete vestibuled corridor trains of the Paris-Lyons Company and the Eastern Railway Company of France. The locomotive of the former is a magnificent four-cylinder compound, with balanced motion, Atlantic type. This superb engine is painted in green and gold, and is said to be capable of hauling a very heavy train 75 miles an hour. The Eastern Company's engine is a four-cylinder compound of the 4-6-0 type, built at the company's shops at Epernay. As an example of fine finishing it could not be surpassed. The frames and braces are like burnished silver.

The Northern Railway of France is represented by one of its chocolate-colored De Glehn four-cylinder compound Atlantics. The carriages are green and elegantly finished, but the compartments are very cramped. The French State railways make a fine show with standard and narrow gauge passenger vehicles, those of the latter type being employed on the Algerian lines.

The Swiss section comprises a magnificent array of the Federal railway's rolling stock, while the equally lavish Italian section contains promise of much improvement under State con-

trol. An example of Signor Planchar's remarkable six-coupled "front-enders" is on exhibition. The cab and fire box are at the front end, and the engine has the appearance of running backward. The advantages claimed are a great width of grate. Both engineer and fireman have a clear view of the road. The six-coupled driving wheels are 6 ft. 3½ ins. in diameter, the four cylinders driving the center-coupled axle. The coal bunkers are carried on each side of the fire box.

Perhaps the best exhibit of all is that of the Austrian State railways. Mr. Golsdorf, chief engineer of the State railways, has on exhibition several of the extremely powerful decapod locomotives, the largest locomotives in Europe. The capacious galleries adjoining the sheds contain a fine collection of exhibits of smaller appliances, the automatic signaling apparatus, being particularly prominent. The exhibition is altogether the best of its kind ever held in southern Europe.

#### The Night Watchman.

Perhaps the most pathetic figure in the railway world is the machine shop night watchman. It would seem as if the dull routine of his existence had withered his mentality and crushed him into a state of settled stupefaction. This is not exactly the case. The leprosy of laziness has poisoned his heart's blood, and mere locomotion is harder to him than the ceaseless toil of the treadmill. At first glance one would think that he led a joyless existence. This also is a delusion. Sitting behind a warm boiler, with his pipe in his cheek, he is the personification of physical comfort. When he goes his weary rounds, and sees in large capitals, "No Smoking," "No Admittance," and other peremptory challenges, he heeds them no more than a dog does the placarded announcement that no dogs are allowed. He goes straight toward the mark. There is a time clock somewhere, and a certain notch in a certain disc, and when he gets his key in there and makes the required turns, his task is accomplished. He shrinks into himself again, and for the next fifty-five minutes he is like the cuckoo spoken of by the poet Wordsworth: "Thou still art an invisible thing, a hope, a mystery."

These remarks are general in their character, and doubtless there are notable exceptions to this classification of night watchman. Some may be possessed of great virtue and great goodness, filling them with a spirit of vigilance that never wearies. If there are such, we have never seen them. On the contrary, we have seen countless superannuated drones. A little inquiry reveals the fact that they are there be-

cause they could not do anything else. Long services in some other capacity entitled them to some kind of consideration, and there they were, not looking for fires or thieves or trouble of any kind, but looking for easy hours and the regular pay day.

It will be generally conceded that machine shops are peculiarly susceptible to fires. Much of the work requires intense heating, not only in forging, but in fitting, and brazing, and soldering, and other work. Few shops there are but have had the misfortune of disastrous fires. The night watchman, of course, was somewhere else when the fire broke out. It is doubtful if it would have mattered much even if he had been there. He might know a fire if his attention was called to it, but he certainly would never think of going out of his way to look for it.

The fault is not so much with the man as with the system. Like the sentinels of an army, the night watchmen should be strong and alert and in the prime of manhood. They should be changed often, and subject to sudden visits from unexpected superiors. They should be well chosen and well paid. The status of the man and the position he holds should be raised something nearer to the degree of responsibility that properly attaches to it. It need hardly be pointed out that the constantly increasing mechanical appliances render the liability to danger from fires of greater degree than hitherto. This is particularly true in the rapid increase of the number of oil-burning locomotives, in the number and variety of gasolene motors, and in the care necessary in the perfect control of the mechanism for the safe-keeping and distributing of inflammable oils in tanks and roundhouses and garages and other establishments where much valuable property, and even the safety of human lives, depends on the intelligent vigilance of the night watchman.

#### Book Notices.

Catechism of the Electric Headlight.

Published by the Brotherhood of Locomotive Firemen's Magazine, Indianapolis, Ind. Price, 50 cents.

This book is of vest pocket size and is a useful compilation of 296 questions and answers concerning the electric headlight, and the whole subject is covered in a very comprehensive manner and goes into the subject down to the minutest details as far as operation and repairs are concerned. The book is well adapted for use as the basis for examination of firemen for promotion as well as for the study by firemen and engineers. There are a number of illustrations on a separate sheet. The book is handy to carry and has a lot

of useful information compressed into very small space.

Turning and Boring Tapers, by Fred H. Colvin. Published by the Derry-Collard Company, New York, 1906, price, 25 cents.

This was the first of the Practical Paper series published by the Derry-Collard Company and the demand for practical information on turning and boring tapers has made a second edition of this little book necessary. Although this is No. 1 of the series it has been slightly enlarged since the first edition, and is well and clearly illustrated throughout.

Manual of Wireless Telegraphy, by A. F. Collins. Published by John Wiley & Sons, New York, 1906. Price, cloth, \$1.50; morocco, \$2.00.

In preparing this manual the author's purpose has been to give detailed and explicit instructions for wiring the various types of sending and receiving apparatus now in general use, the adjustment of the instruments, tuning and syntonizing the circuits, testing the devices, and finally the management of ship and shore stations. The book should be useful to all those who are concerned with the operation of wireless telegraph apparatus; also to those who are interested in the subject.

The Steel Square as a Calculating Machine, by Albert Fair. Published by The Industrial Publication Co., New York, 1906. Price, cloth 50 cents.

Any one who glances over this book must be struck with the number of difficult problems in all branches of mechanics that may be solved by the aid of the common steel square without any calculation whatever, and without any necessity for laying down elaborate diagrams. The steel square has been looked upon as a tool used almost exclusively by carpenters. This instrument enables us to lay out work with ease and accuracy which few can realize, and its use is not confined to carpenters alone. The following example is taken from the pages of the work. Suppose there were five or six pipes of various sizes leading from different parts of a house and all to discharge into one main pipe: What should be the size of the latter?

The steel square enables us to solve such a problem without calculation. In the volume before us the explanations are full, clear and simple; any intelligent person can understand them, and put them in practice.

American Stationary Engineering, by W. E. Crane. Published by The Derry-Collard Company, New York, 1906. Price, \$2.00.

This book is intended to be a plain talk on every day work about engines, boilers and their accessories. It is not

designed to be very scientific and does not go into mathematical questions.

The author is well known and is a practical man. He has written this book for the manager or superintendent of the power plant as well as for the engineer or fireman, and indeed for all interested in the subject. There is a list of examination questions beginning on page 256 which gives a good idea of the points on which a man should become informed.

Notes on Patents and Patent Practice, by Paul Synnestvedt, L.L.B. Published by the Federal Publishing Association, Pittsburgh, Pa. Price, \$1.00.

Our inventors would do well to peruse this book, which is a compilation of notes on patents and patent practice based on the personal experience of the author for a number of years, and is intended to supply a need for some concise presentation of rules which may prove especially useful in preparing patent applications. It presents in brief and concise form the proper procedure in all cases. The work ought to have a wide circulation among inventors as the information contained in the book would prevent much of the disappointment experienced by inventors in regard to the legal steps necessary for the conserving of their rights.

Elements of Gas Engine Design, by Sanford A. Moss, M.S., Ph.D. Published by D. Van Nostrand Co., New York. Price, 50 cents.

Professor Moss has condensed in this little book of 200 pages all the fundamental principles with which a designer of gas engines should be familiar. The aim has been to present a complete exposition of the elements of all subjects of interest to the designer. The reader is presumed to be familiar with the general features of the gas engine and its operation and the presentation of the subject in fourteen chapters ranging from the chemistry and physics of gas engines, with analyses of fuels and discussions and calculation on cylinder action, exhaust and admission, is ably supplemented by a series of tables on the properties of gases, and gas mixture calculations and mean effective pressures, the whole forming a very complete presentation of a subject of rapidly growing interest. It might be added that the learned Professor possesses a style of writing not common to authors of scientific works. His fine mastery of English is marked by directness and clearness.

The Steel Square Pocket Book, by D. L. Stoddard. Published by The Industrial Publication Company, New York, 160 pages. Price, 50 cents.

This book is a practical and handy treatise giving the best methods of using the carpenter's steel square. It contains 150 illustrations and is a condensed

compendium of information about the square which can be referred to quickly, the size of the book enables it to be carried in the pocket. The book has the double merit of originality and is in every way up to the times. It ought to be in the hands of every carpenter, especially house builders, and the most experienced will find that there is a wealth of information in the little book that reveals possibilities in the use of the carpenter's square that ought to be more widely known.

Locomotive Dictionary, by Geo. L. Fowler. Published by Railroad Gazette, New York. Price, \$6.00.

This valuable contribution to railway and locomotive literature has been compiled under the direction of a committee of the Master Mechanics' Association, Messrs. J. F. Deems, A. W. Gibbs and E. A. Mitchell. The book is similar to the Master Car Builders' Dictionary. It defines the terms commonly employed by motive power men all over the country, and has numerous illustrations showing American and British Practice. It can be obtained through this office.

Digest of Proceedings of the Railway Signal Association from 1895 to 1905, Vol. I and II, compiled by the executive committee, has been published and can be obtained from this office. Price, \$2.00 each volume. The books are bound in cloth and are well illustrated. They contain 480 and 543 pages respectively.

#### Australian Sleepers for India.

It is interesting to notice from an exhaustive report published in the Indian and Eastern Engineer that the important question of procuring railway sleepers for the East Indian Railways has found a practical solution in the introduction of the best Jarrah timber from western Australia. Mr. J. Adam, Executive Engineer, India, has been conducting a thorough examination of available timber for use as sleepers, and stamps the use of the Jarrah timber as the most durable as well as the most economical available for Indian railways. The timber is nearly as heavy as teak, varying from 65 lbs. to 75 lbs. per cubic foot. It is particularly strong in the important requirement of holding the spikes well. The regulations in regard to cutting and seasoning and shipping the timber are already embodied in statutory enactments, a provision being that the sleepers on arriving in India are covered with a layer of earth during the period of stacking previously to being placed in the railways. Their durability is estimated at 18 or 20 years. The sea freight amounts to 35 cents each. The timber grows in great abundance in western Australia.



# Our Correspondence School

In this department we propose giving the information that will enable trainmen to pass the examination they are subjected to before being promoted. If any of our students fail to understand any part of the instructions, we will gladly try to make them plainer if they write to us. All letters intended for Our Correspondence School ought to be addressed to Department E.

## Third Series—Questions and Answers.

170.—Upon whom does responsibility rest for accident at such places as yard limits and coaling stations?

A.—Both engineman and conductor of any train approaching yard limits and coaling stations.

171.—What rights have yard engines in yard limits?

A.—Yard engines which are assigned to service in a yard may work in that yard without train orders and need not cover headlight while working in sidings in the yard. In shifting cars in the yard it is not necessary to have a switchman on the front of the cars being moved. Yard engines cannot work on the main line within yard limits, on the time of regular trains without being fully protected by hand or fixed signals.

172.—If a train should part while in motion, what is required of trainmen?

A.—Trainmen should give the signal that the train has parted and should stop the rear portion as soon as possible and a flagman should be sent back to protect the rear portion of the train.

173.—What is required of engineman?

A.—He should reply to the signal that the train has parted and should keep the front portion of the train in motion if possible until the rear portion is stopped. If train becomes delayed so as to get on the time of an opposing superior train a flagman should be sent out ahead.

174.—Has the front part, the right to go back for detached portion of train?

A.—Yes. The forward part of the train has the right of track to return to the rear portion, and when coupled up again the rear flagman should be called in and train may proceed, picking up forward flagman if one has been sent out.

175.—Do you understand that the front end of train must be at all times protected against opposing trains of the same or superior class that may be due?

A.—Yes.

176.—Do you understand that it is necessary for front portion to be protected while moving backward?

A.—Yes, if train gets on the time of an opposing superior train or under certain circumstances when clear vision is obstructed, a flagman should be sent out ahead.

177.—At what speed should the front portion run while backing up to recover detached portion of train?

A.—Answer according to particular

rules of railway company. Slow speed and the utmost caution are necessary in backing up for the rear portion of train. The front portion, when returning for the rear portion, should be preceded by a flagman, not only to protect it from collision with the rear portion or middle portion, in case the train has broken in more parts than two; but so that he may find any part of the draft rigging that may have pulled out, or other obstruction which may have fallen on the track.

178.—Should the detached portion be moved or passed around by any train



PULLING CARS IS OUR BUSINESS

or engine before the front portion comes back?

A.—No.

179.—In case a train breaks in two while pulling out of a side track, leaving the detached portion in the side track, do you understand that a flagman must go back as per rule?

A.—Yes, for the reason that no train must be permitted to run by the rear portion which is on the side track.

180.—To what trains do these instructions apply?

A.—To all trains.

181.—When the men on the rear portion discover that train has broken apart, what are they required to do?

A.—They must signal enginemen that the train has parted and bring the rear portion to a stop as soon as possible and send out a flagman to the rear.

182.—Are there any circumstances by

which trainmen are authorized to deviate from these instructions?

A.—No, unless special instructions by the railroad company govern the case.

183.—What are they?

A.—Answer as per special rules of the railroad company.

184.—In case a train breaks in three or more parts, or in any case not provided for in the foregoing rules, what is required of trainmen under such circumstances?

A.—They must signal engineman that train has parted and stop the rear portion of the train. They must never assume that the train has only broken in two parts, as at night those on each portion of the train may be able to see the lights on the other, and yet have cars on the track between them, unknown to either party. They must do everything to avoid collision with the rear or middle portions and protect rear of train by a flagman. They must be governed by circumstances, remembering that derailment may have taken place, but should endeavor to prevent accident or even misunderstanding with those on front portion of train.

185.—Should they expect to find the detached portion in motion?

A.—Yes.

186.—When a train is being pushed by an engine (except when shifting and making up trains in yards) is it necessary to have a flagman on the front part?

A.—Yes.

187.—What is required of the conductor and engineman in such cases?

A.—They must keep a sharp lookout for signals from the man in front on top of cars and be prepared to stop.

188.—May a train start from a station, or leave a junction point on the time of an overdue train of the same class running in the same direction?

A.—Yes, if the overdue train is of the same or inferior class. If the overdue train is of superior class they must receive orders from the train dispatcher.

189.—How should the overdue train proceed?

A.—The overdue train should proceed so as to maintain the time limit of at least 5 minutes between the train ahead, unless block signals are used, and should approach all sidings prepared to stop, keeping a sharp lookout for the train ahead.

190.—What do you understand the

phrase "starting from a station" to mean?

A.—This phrase means leaving a terminal, or junction or point where the train schedule begins, or divisional point where crews or engines change.

191.—How must the train be, in regard to its own time, to thus leave a station or junction point ahead of an overdue train?

A.—It must not leave the junction ahead of its regular schedule time.

192.—If it is late, how must it proceed?

A.—It may proceed if the overdue train is of the same or inferior class. If the overdue train is of superior class, the train desiring to leave ahead of it, must get orders from the dispatcher.

193.—How should the overdue train be governed?

A.—It may proceed but should approach all sidings prepared to stop, and keep a sharp lookout for the train ahead.

194.—Does a delayed train that falls back on the time of another train of the same class lose its rights?

A.—No, it will proceed on its own schedule.

195.—How must a train proceed from a way station on the time of an overdue train of the same class?

A.—It must approach all sidings prepared to stop.

196.—When do regular trains lose all their rights?

A.—When they become twelve hours late.

197.—In case you overtake a train of the same or superior class, that is disabled, so that it can not move, how would you proceed?

A.—If necessary take the orders and assume the schedule of the disabled train to the next open telegraph office.

198.—Upon arriving at the first open telegraph office, what is the duty of such train?

A.—To report the matter to the superintendent.

199.—What will the disabled train do?

A.—It should assume the rights of the train with which it exchanged orders.

200.—What is meant by open telegraph office?

A.—An open telegraph office is one in which there is an operator on duty.

201.—How must all messages in regard to the movement of trains, or the condition of track or bridges be given?

A.—They must be given in writing and on the form prescribed by the railway company.

202.—By whose authority shall trains display signals for a following train?

A.—The superintendent; unless some other officer is designated by special rule of the railroad company.

203.—What authority is required for running an extra train?

A.—Special orders from the superintendent or other officer designated by the railroad company.

204.—When signals displayed for a following train are taken down, at any point before the following train arrives, how should the conductor be governed under the following conditions:

(a) When there is an operator or switchman; and,

(b) Where there is no operator or switchman, or other provision for the purpose?

A.—(a) The conductor must arrange with the operator or switchman to notify opposing trains of same or inferior class.

(b) A flagman must be left to notify opposing trains of the same or inferior class.

### Calculations for Railway Men.

BY FRED H. COLVIN.

#### Making a Square Corner.

It often happens in the shop that we want to make a square corner on some

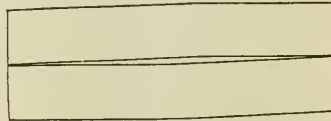

FIG. 1.

#### EXPERIMENT WITH BOWED RULES

piece of work and may not have all the tools handy or those we have may not be exactly accurate. And in any case it is always well to know the "how" and "why" of things so that we can get along without all the tools or make our own, or test those we already have. So we do a little figuring at the problem of

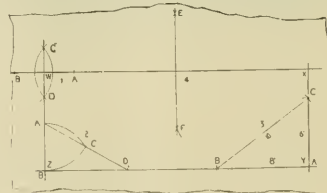

FIG. 2.

#### METHOD OF PROVING A RULE.

making a square corner without the aid of any tools but a pair of compasses or dividers, a straight ruler or scale and a pencil or scratch awl if we use sheet metal instead of paper to work these problems out on.

To begin with, let us see if our rule is straight and if not, to know how much it is out, and where. It does not take any expensive apparatus to do this. Just lay your rule down on the paper or metal, we will use a sheet of tank iron as well as anything, and

scribe a line along the edge of the rule on the iron. Then turn the rule over and with the ends at the ends of the first mark, draw another line. If they agree, that is if the second line is the same as the first, the rule is straight. If they are bowed as shown in Fig. 1, the rule curves in, and the distance between the lines in the center is twice the amount of error. So we know how much to take off to make it straight. We probably have a good rule, but it is well to know how to test any tool we have as it gives us more confidence in them.

First of all we must have a base line to work from and so we draw the straight line *B X* on the sheet. The edges are shown very rough to show that we pay no attention to the sheet itself in squaring it up but work entirely from the line we have made.

The first method of laying off the square corner is shown at the left, in the corner marked 1. Select any two points such as *A* and *B* and take in the dividers, any distance more than half the distance. Then, with the points first on *A* and then *B*, scribe the arcs cutting each other at *C* and *D*. Draw a line through these two points and you have a straight line at right angles to the line *B X*. This gives us the first square corner and from this we could find the others by measurement, but instead of this we will see other ways in which this can be done.

The lower left-hand corner gives the next method and marked 2.

Take any space in the dividers as *A Z*. With the point on *Z* make the arc from *A*. With the point on *A* make the arc from *Z*. These will cross in *C*. Draw a line from *A*, through *C* and continue it indefinitely. With the same distance in the dividers, put one point on *C* and cut the line we have drawn at *D*. Then a line drawn from *B* or *Z*, through *D*, will be at right angles to the vertical line drawn before and we have the third line of the rectangle drawn.

It is well to note also, that the triangle just drawn is a thirty-degree triangle, so that if we want to make a triangle of this kind at any time or to test one that we already have, here is a way of doing it with almost no trouble.

The next method is perhaps the handiest for some places and is known as the "6, 8 and 10 rule," from the fact that it was discovered, centuries ago, by an old Greek philosopher, that a triangle having sides in the ratio of 6, 8 and 10 was a right angle triangle. This can be in feet, inches or miles and the same rule holds good. Or it can be any other numbers in this same proportion such as 3, 4 and 5; 12, 16 and 20 or any other combination in the same ratio.

This is very handy in laying off the end of a board square, or squaring the end of a lot, laying out a tennis grounds or anything else you desire. Simply measure off the distance with dividers or a rule and you can soon get the hang of it.

This completes the rectangle and all without a single reference to outside edge of the sheet.

The same method as we used in making the first corner can be used to divide a line in the exact center and is shown in dividing the top line as in Fig. 4.

Here we again take a distance in the dividers of more than half; we can tell at a glance when we get more than half and the exact amount is of little consequence, and scribe the arcs that cut at *E* and *F*. Join these by a straight line and we have the distance *WZ* cut in two equal parts.

While the machinist in the railroad shop may not run up against these exact problems in his work, he will find these principles very handy in many ways and the time taken to practice them on a scrap of tin or elsewhere will not be wasted by any means. It is the first lesson in practical geometry, although it may sound easier if we call it by another name.

## Questions Answered

### VALVE SETTING AND VALVE TRAVEL.

(111) G. H. P., Willow Glen, N. Y., writes:

1. I do not understand when you say the valves of an engine are set "line and line" forward and  $\frac{3}{8}$  of an inch blind on the back motion. Please explain. A.—Valves are said to be set line and line when, in full forward gear they have no lead. That is, at the beginning of the stroke the line of the edge of the valve coincides with the line of the edge of the steam port. The back motion set  $\frac{3}{8}$  in. blind, means that in full throw in back gear, the valve has a distance of  $\frac{3}{8}$  of an inch to travel after the piston stroke has begun, before the steam port begins to open. This is a case of sacrificing the back motion for the sake of the forward.

2. When you say the valve travel is 6 ins. do you mean from the time the engine leaves the center until she reaches the other center? A.—Valve travel 6 ins. means that in full gear the valve moves over a distance of six inches from its extreme forward to its extreme back position; if you look at the valve stem you will see that six inches of valve stem passes in and out of the gland.

### "TANDEM CONNECTED" ENGINES.

(112) J. M. C., Paducah, Ky., writes:

On a piston valve engine should the side rod break between the intermediate and main driving wheels, could you bring engine in, when eccentrics are on intermediate wheels? A.—The engine you describe is sometimes spoken of as a "tandem connected" engine, and when one side rod breaks it is safe practice to take down its mate on the other side. Under these circumstances there is nothing to make the axle carrying the eccentrics revolve in unison with the main driving axle, and the engine should be towed in. Engines disabled as you describe have been run by leaving the side rod up on the good side, but it is not a safe thing to do, because there is no guarantee that one side rod will always cause the wheel to revolve in the same direction as the main driver. If the main drivers slipped at or very near the forward or back quarter, the one side rod might turn the intermediate wheel backward with disastrous results.

### FIVE-POUND REDUCTION K TRIPLE.

(113) J. R. S., Altoona, Pa., writes:

I have seen quite a number of K triples in trains that we haul, and when a service reduction is made the brakes seem to go on quicker and hold better than they do with the common quick triple. Why is this? A.—As already explained in the Air Brake Department of this paper, April and June numbers, the K triple in service applications vents brake pipe air into the brake cylinder. This action not only adds to the cylinder pressure in the early part of the service application, but it causes an earlier reduction in the rear portion of the brake pipe, which causes the ordinary quick action triples to respond more promptly. Thus all brakes apply much quicker than if no K triples were in the train, and hence a shorter and smoother stop is made. With a train of 75 or more cars all equipped with K triples, a five pound service reduction will stop the train from a speed of twenty miles per hour in the same distance that a twenty pound service reduction will stop the same train equipped with the present standard triple under the same conditions of load, speed, etc.

### IMPORTANT DUTIES AND HIGH PRESSURE.

(114) J. W. B., Logansport, Ind., asks:

1. What is an engineman's first and most important duty? A.—In taking charge of a locomotive the first duty of an engineer should be to see that there is sufficient water in the boiler. He should test the gauge cocks and water glass and satisfy himself they are working properly. He should see that flues and fire box are not leaking, the fire in good condition and ash pan clean. He

should make sure that the tools required are on the engine and in good order. He should examine the report book and note if the work booked by the last man has been done, and he should examine the engine for defects which may give trouble on the road.

1. Name the four advantages, exclusive of steam economy, which result from using high pressure of steam with short cut off, as compared with throttled steam and late cut off? A.—(a) Drier steam may be obtained with high pressures. (b) Less water is evaporated and less coal is burned to do the same work where high pressure steam is used, because less steam is required to enter the cylinders. (c) Less steam entering the cylinders means less steam to get rid of at the end of the stroke and free exhaust, especially for high speeds, is an advantage. (d) The expansive force of high pressure steam is much greater than that of low pressure steam, and while expanding in the cylinders it is doing useful work and the work obtained by the expansion of high pressure steam is clear gain over the results to be had by working at low pressure.

### RELIEF VALVES.

(115) R. E. L. C., Duquesne, Pa., asks:

Why is it that they take the release valves off the engines? Does not that hurt the valves? A.—We suppose you refer to the relief valves on the steam chests of engines. Taking off relief valves has not become a universal practice. In some cases where through neglect these valves have leaked very badly they may have been removed, as no relief valve would be preferable to having the engineer's view obscured by steam. These valves serve a useful purpose when in proper working order, but, like everything else about a locomotive, they have to be kept in proper repair.

### EXPERIENCE WITH N. Y. BRAKE VALVE.

(116) J. A. D., Syracuse, N. Y., writes:

Some time ago we had a startling experience with a New York brake valve, which has set us all thinking, and it was this: While working the brake under ordinary conditions of service all at once, without notice, the brakes would not go on when the handle was placed in service notch; it did no different when placed in the emergency notch. When the brake valve was taken apart to find out what was the matter, the main slide valve was found disconnected from the brake valve handle, and did not move. As this would put a fellow in a bad fix if he wanted to stop in a hurry, as, for instance, if he was heading into something such as a drawbridge or a station terminal or anywhere he wanted to stop right away, we would like to know when in this fix the next best and

quickest move to get the brakes on? A.—It does not often happen that the main slide valve and the brake valve handle of a New York brake valve become disconnected while in service on the road, but when it does, resort to some other means of opening the brake pipe to the atmosphere must be had. If we were caught in such a plight as you instance, our first move would be to apply the straight air; then call for brakes with the whistle, so that the train crew could open a conductor's valve or apply the hand brakes. After doing this we should proceed if possible to the pilot stop cock to open that.

If any brake pipe union near the brake valve can be opened with a wrench or broken with a hammer, this should be done. On account of the design of the New York brake valve there is a possibility always present that the valve will become disconnected while in service on the road, and for this reason a three way cock should be placed in the brake pipe, just below the brake valve, that could be used to apply the brakes in case of such a thing occurring. Formerly such cocks were supplied with this type of brake valve.

#### BLOCKING EQUALIZER FOR BROKEN SPRING.

(117) J. E. H., Charlestown, Mass., writes:

What way does the end of the equalizer go when the driving spring breaks supposing the equalizer was between the frames. I would say that the end of the equalizer next to the broken spring would go down. Am I right? A.—Yes, you are right, the position of the fulcrum of the equalizer does not alter the fact that when a driving spring breaks, the frame, which carries the weight of the boiler, etc., tries to go down and the end of the equalizer next the good spring goes up and the other goes down.

#### PISTON RINGS IN GOVERNORS.

(118) P. D. M., North Ipswich, Australia, asks:

What practice is adopted in fitting packing or piston rings in Air Pump Governors? Is it necessary to bore out place where ring works and a new ring required to be put in. Is it necessary to rub them up to a face? If so, is there anything you can suggest to help bring a cylinder face to make an air tight face? A.—In replacing worn pump governor piston packing rings, see that the cylinder is neatly trued up, and that the new ring is a neat fit in the packing ring groove and that it works freely, but not loosely, in its cylinder. A little rubbing in oil is all that is necessary to face up the ring.

#### RIGID AND SWING CENTERS TRUCKS.

(119) H. G. Raton, N. M., asks:

1. What are the advantages of

what is called the cradle engine truck over the old rigid truck center casting? A.—What you call the cradle truck is practically one with a swing bolster. This form was devised so that when the engine truck entered a curve and was deflected from the straight line which it had followed on straight track that the deflection of the engine itself might be gradual and without shock. Many trucks are now made with what are called three-point hangers which while such a design avoids shock and sudden side movements of the front of the engine, yet swings the whole over easily and insures the centering of engine over the truck as soon as a tangent is reached.

2. If the cradle pins were worn badly and allowed the cradle casting to get down solid on the truck so it could not swing, would it have a tendency to derail the front drivers? A.—The swing bolster guides more easily than the rigid center and is an advantage on engines with long wheel bases when rounding sharp curves, but when unable to swing, it practically makes the engine equal to one with a rigid center truck and it has the further serious disadvantage that in the position of which you speak, it will hamper or prevent the truck from swiveling or turning about the center pin. Such a truck would be held in one position between the frames and if it did get a turn one way on a curve it would not come back to the central position on straight track and might be in bad shape to take a curve in the opposite direction.

3. Would you consider it safe to run an engine at a high rate of speed with the cradle pins broken and the cradle casting down on the truck casting, without anything to hold it central? A.—We would not consider it safe.

#### BLOW ON UP STROKE.

(120) P. D. M., North Ipswich, Australia, writes:

What will cause an 8-in. pump to blow on up stroke only? There is no perceptible blow in exhaust on down stroke. The pump in question was thoroughly repaired, the main valve bush, cover, and the reversing valve bush bored out with a new reversing valve supplied. The main valve piston had new rings put in it. The trouble is noticeable with this particular pump only. A.—Very likely the gasket between the top head and the steam cylinder leaks at the point where it separates the steam passage leading to the lower end from the upper end of the cylinder. On the down stroke a leak at this point would not cause a blow because the exhaust port from the upper end of the steam cylinder is closed, but on the up-stroke it would, because the exhaust is open.

#### LENGTH OF MAIN ROD.

(121) H. C., Scranton, Pa., asks:

Is there any rule regulating the length of the main rod in relation to the cylinder stroke? A.—There is no exact rule in regard to it. The dimensions of each depend on the particular design of the engine. The longer the main rod is the more easily will the cross head run on the guides avoiding the severe blows incident to a short coupled engine. If practical the main rod should be from two to three times longer than the stroke of the piston.

#### CAST IRON AND STEEL.

(122) W. I., Coldstream, N. Y., writes:

How can good cast iron and poor cast steel be known without chemical or physical tests? A.—It will be observed in breaking cast iron that there is a white outer shell, not so white as the shell of an egg but equally distinct, the inner metal being of a dark gray color. Broken steel has no outer sheathing and is invariably of a finer, clearer texture than cast iron.

#### Locomotive Dictionary.

We have had the pleasure of receiving a handsomely bound volume of the new and important work called the Locomotive Dictionary. The book came to us through the courtesy of the American Locomotive Company, who we believe have now exhausted the supply at their disposal. The dictionary is a work which has been long wanted in the railroad world and its advent will be appreciated. It has been compiled from the best authorities for the American Railway Master Mechanics Association. The work has been ably done by Mr. George L. Fowler, under the supervision of the committee appointed by the association. The committee consisted of Mr. J. F. Deems, general superintendent of motive power of the New York Central Lines. Mr. A. W. Gibbs, general superintendent of the Pennsylvania Railroad, and Mr. A. E. Mitchell, formerly superintendent of motive power of the Lehigh Valley Railroad. The Locomotive Dictionary is an illustrated vocabulary of terms which designate American railroad locomotives, their parts, attachments and details of construction. It also has definitions and illustrations of typical British practice. There are five thousand one hundred and forty-eight illustrations and altogether the book is a very substantial addition to the library of any railroad man. The book sells at \$6.00 a copy and can be procured from this office.

The greatest life is that which has been the most useful, and has been able to perform its allotted tasks cheerfully and well.

# Air Brake Department

CONDUCTED BY J. P. KELLY

## Large Pump and 100-Car Train.

The advisability of adopting larger air pumps for long trains has been seriously debated by those most interested in the efficient maintenance and the satisfactory operation of the air brake, but until recently the advocates of the smaller pump had, apparently, much the better of the argument.

One of the strong points made in favor of the smaller pump is, that because of its limited capacity it will make it necessary for railroads to maintain the brake pipe practically free from leakage. This consideration to them seemed to possess greater weight than that of the advocates of the larger pump, which is that a large air capacity pump would quickly charge the brake pipe and the reservoirs, thus save time—an important element in successful railroading—in yards and terminals and it would also maintain the standard brake pipe pressure against a considerable amount of brake pipe leakage while the train is on the road and do all this without overworking, heating and danger of failure.

That brake pipe leakage is an undesirable thing everybody acquainted with train handling knows; but that cars must be moved within reasonable time is equally well known. Therefore, charging and testing should be done with as little delay as is consistent with safety.

With large pump capacity and considerable brake pipe leakage the pressure may be kept up to the desired point while the brakes are released, something that the small pump cannot do. It is no doubt true that in some cases excessive leakage is allowed to exist because this can be done, but where it is permitted the company pays dear for it in many ways. After the engineer commences to apply the brakes the leakage gets in its bad work, and the annoyance, cost and damage resulting from the loss of control of the action of the graduated brake are considerations in themselves apart from any other the pump capacity may have, sufficient in our way of thinking to induce railroads to maintain the brake pipe and the reservoir connections in reasonably tight condition.

The time has undoubtedly come when the small pump, that is the  $9\frac{1}{2}$  in., can no longer be considered the proper instrument for supplying air for modern long trains.

At the time this pump was brought out it was considered by all air brakemen the correct size of air compressor to handle the trains satisfactorily that were then controlled by the air brake. That it was equal to the work imposed on it by a 50 car train made up of 8 in. equipments, was long ago amply demonstrated. It could and did keep the brake pipe and reservoirs charged to a pressure of 70 lbs. and this while brake pipe leakage existed amounting to two or three and sometimes more pounds per minute; but when the number of cars in the train began to increase above

other causes it will require more than this. It will be readily admitted that this is quite a long time to get the brakes charged so that leaks may be detected and repaired, and the brakes properly tested before the train starts on its trip. If many leaks exist in the brake pipe it is unlikely that the pump will be able to charge the train to standard pressure at all.

From tests made to determine the brake pipe leakage had with a brand new test train of 50 cars we learned that it equals about two pounds per minute. That had with the average train is about three pounds per min-

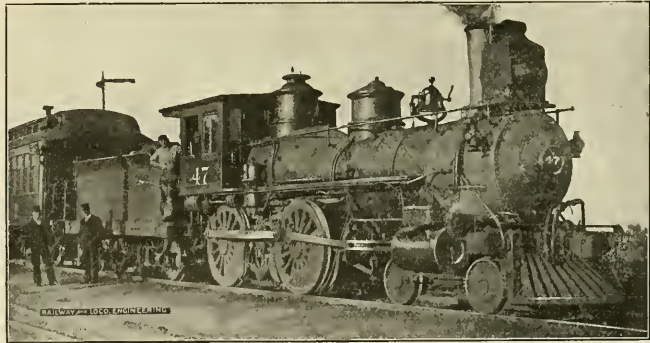

"WE ARE ALL READY TO GO"

fifty, the work on the  $9\frac{1}{2}$  in. air pump began to tell on it. Unless it was in first-class condition it could be seen that it lacked in power to supply the needed air to maintain the standard pressure. Hence, under these conditions, more time was consumed in yards in charging and testing brakes than could well be afforded; on the road more time was required to recharge after a service application, also after a break in two to the release after recoupling.

The  $9\frac{1}{2}$  in. pump in good condition, running at the rate of 120 single strokes per minute, has a capacity of from 28 to 30 cubic feet of free air per minute. A train of 100 cars equipped with 8 in. equipments will require, to charge it to a pressure of 70 lbs. 1,002,500 cu. ins. or 632 cu. ft. of free air, and the time required by the pump to furnish this amount of air will be about 23 minutes. That is, assuming that the brake pipe and the auxiliaries are absolutely tight. In actual practice due to leakage and

ute; with no more than this amount the brake pipe is usually considered practically tight.

A little calculation shows us that a brake pipe leakage of three pounds per minute from a brake pipe of 100 cars, means the loss of about 47,000 cu. ins., or 27 cu. ft. of free air, which is about equal to the capacity of the  $9\frac{1}{2}$  in. pump. Hence, it is clearly shown that this pump cannot be expected to maintain the pressure in a 100 car brake pipe even if no brake applications whatever were required, and most assuredly it could not be expected to fulfil the requirements of charging, of testing, and of service braking on both level and down grades under average conditions.

Therefore, it is clear that a larger pump than the  $9\frac{1}{2}$  in. is required for modern service and since it was considered ample in capacity for the 50 car train, neither too large or too small, it would appear that a pump whose capacity bore the same relation to the 100 car train of to-day

that the  $9\frac{1}{2}$  in. pump did to the 50 car train of ten years ago would be about right.

The modern freight car is usually equipped with a 10 in. brake cylinder and the time is not far distant when all freight cars will have this size brake cylinder, and a reservoir to correspond. The capacity of this equipment, brake pipe and reservoir combined, is about 3,450 cu. ins. The quantity of free air required to charge a 100 car train of these equipments to 70 lbs. pressure is 1,640,000 cu. ins., or 950 cu. ft. The capacity of the  $8\frac{1}{2}$  in. cross compound pump working at 80 cycles per minute against a reservoir pressure of 100 lbs. is about 152 cu. ft. of free air per minute. Hence, the time required by this pump to charge the 100 car train would be a trifle less than 7 minutes, assuming everything absolutely air tight which is about 16 minutes less than the  $9\frac{1}{2}$  in. requires. The relation of the capacity of this pump, therefore, to the 100 car train of 10 in. brake equipments, is somewhat greater than that of the  $9\frac{1}{2}$  in. pump to the 50 car train of 8 in. equipments.

We are not so sure that the larger pump tends to increase brake pipe leakage through neglect any more than the smaller pump tends to decrease it because of its limited capacity; we think there are good reasons why the larger pump should tend to decrease it. Take the difference in time required to charge the train. The  $9\frac{1}{2}$  in. pump in practice consumes nearly five and one-half times as much time as the  $8\frac{1}{2}$  in. cross compound. Before leaks can be satisfactorily detected there must be considerable pressure in the pipes and reservoirs, and this necessary pressure can be furnished so quickly by the larger capacity pump that the inspectors can start in at once to stop them, while with the smaller pump the inspectors would be required to wait sometime for the pressure to be pumped up to enable them to find the leaks. The yard master would want the train pulled out on the road and started on toward its destination before this could be done.

In road service the larger capacity pump has the advantage in nearly every particular over the smaller, and it will enable the train crew to observe the rules which require testing the brakes after each change in the train make up much more satisfactorily than is now done in many cases. If the train breaks in two while in motion, no more time is required after recoupling to make a complete release of the brakes than is needed for the air to get back through the pipe to the last car. In less than one minute the cross compound pump can charge a 100 car brake pipe from zero to 60 lbs., and this without

taking any air from the main reservoir. Hence, with a 50,000 cu. in. main reservoir charged to 90 lbs., placing the handle of the brake valve in release position will cause an equalization in an empty 100 car brake pipe of 48 lbs., and the pump will be required to labor but a very short time to supply the additional air necessary to release all brakes, probably not more than 8 or 10 seconds.

As usually happens, however, trains break in two not between the engine and tender, but back some considerable distance from the engine, so that the portion attached to the engine is usually always charged up when the recoupling of the brake pipe hose is made; hence the time required to release the brakes on the rear portion will in practice be seen to reduce to an almost insignificant item. To be able to recouple, release, recharge and get under headway in a very short period of time is in itself a matter of considerable importance on busy railroads.

The locomotives of to-day are equipped with bell ringers, pneumatic sanders, air operated water scoops and fire doors, all requiring a supply of compressed air from the pump, and they make an additional demand on the air supply. To sum up, it is quite clear that the  $9\frac{1}{2}$  in. pump is no longer able to meet the demands satisfactorily, as a comparison of its capacity with the quantity of air leaking away from a practically tight 100 car brake pipe clearly shows. It remains, therefore to choose a larger pump or to apply two pumps whose capacity is not only sufficient to meet the demands of the present but also those increased demands which are sure to come as the 8 in. equipments are retired and the 10 in. equipments take their place. In choosing a larger pump regard should be had for one that can compress the requisite quantity of air needed economically, and one that will be reliable in service, free from heating and break downs.

Some roads may prefer to apply two pumps, and at one time it looked as though two  $9\frac{1}{2}$  in. pumps would be about right; but as we regard the situation at present, if two pumps are applied they should each be larger than the  $9\frac{1}{2}$  in., as one  $9\frac{1}{2}$  in. pump will not supply the leakage in a 100 car train when it exceeds three pounds per minute without overworking and getting hot and it could not possibly handle the brakes satisfactorily if the other should fail.

#### The "K" Triple.

After a very careful and exhaustive series of tests, covering all kinds of freight service and extending over a

long period of time several roads have decided to adopt the "K" triple valve.

All new freight equipment, ordered in future by the Pennsylvania roads in future, is to be equipped with this type of triple, and the Duluth and Iron Range Road has found it so much easier to handle the trains in their heavy service, when the cars are equipped with the quick service triple than it is with the older type, that they have adopted it as their standard. This road has to weigh a great many cars, and they find that spotting them on the scales can be accomplished with greater ease and accuracy when they have the "K" triple than it can be with the ordinary type.

Both these roads have heavy grades and on them the trains equipped with the "K" triple can be handled easily with a larger margin of safety than formerly. A more uniform rate of speed can also be maintained while descending, and this proves an advantage in many ways other than in a saving of time.

Those roads that are adopting the quick service triple are already commencing to feel their advantages, since an improved action of the brakes on trains but partially equipped with them is quite noticeable.

It seems to us that as the number of "K" triples in service increases a diminution of cost in renewals of air hose must result, and for this reason. The majority of freight trains consisting of over 60 cars will probably never exceed a speed of 25 mile an hour, and a 5-pound service application will be about all that is needed to stop them as this with the "K" triple is the equivalent in stopping efficiency of a 20-pound service reduction with the triples now in use. Taking the standard brake pipe pressure at 70 pounds, a 5-pound reduction will reduce it to 65 pounds, and this does not make much difference in the pressure. Hence, when the release is made, there will not be such a heavy increase of pressure on the hose, tending to rupture it as is now the case in full service applications. Expressing this another way, after the brake pipe is once fully charged the hose will be relieved of sudden heavy increases in pressure at the moment of release, and as so much less air will be required to recharge the brake pipe after each application the wear on the interior lining of the hose will of necessity be reduced.

The uniform and quick service action of this triple in service applications will tend to cut down the stresses on the draft gear rigging as well as does the important feature of holding the slack bunched in release at slow speeds prevent the tendency to pull the cars apart.

The following comparison between the quantity of free air used in making a service stop with a 100-car train with the quick service and with the ordinary triple, the first requiring only 5 lbs. and the other 20 lbs. reduction to accomplish the same work is of interest as showing their economical features.

With a 5-lb. service reduction the "K" triple 100-car train can be stopped in about 900 ft., from a speed of twenty miles per hour, and they will use about 68 cu. ft. of free air to accomplish this work. With the ordinary triple a 20-lb. reduction will be required to make the same stop and they will use 272 cu. ft. of free air, thus making a difference of 204 cu. ft. of free air in favor of the "K" triple. That is, there is 204 cu. ft. of free air less to put back into the brake pipe after each service application when the "K" triples are doing the braking.

#### A New Stunt.

Recently while supplying a train of over fifty cars with air, the upper intermediate discharge valve seat of a cross compound pump got loose enough to permit back leakage from the high pressure air cylinder into the low pressure. This leak caused the pump to run slower than usual, but did not prevent it from supplying the requisite quantity of air to handle the train perfectly. There was no engine failure in this case, because of air pump failure, to record.

In similar cases of this kind with other pumps, it would be necessary to cut the locomotive out, and to send for another one to haul the train to its destination.

#### Good Metallic Packing.

Editor:

I have read of claims made for excellent service given by different kinds of air pump piston rod packing, which leads me to state I have had an 8 in. air pump changed to a compound fitted with a metallic packing in the stuffing boxes, that has been in service over three years. There has been one ring put in each end during that time.

Another pump 9½ ins. in road freight service thirteen months, two others in passenger service nine months, one engine making 312 miles daily. There have been no repairs on either of the above packings, only occasional tightening and then securely locked. The lock nut is made out of worn piston rod packing nuts by cutting them down to a thin ring, then placed on the stuffing box before putting in the piston. "If I were king," I would put a lock nut on all pumps to secure the packing nut, then there would not be so many air pumps running hot. This packing I take from the mold and place

in the pump without any machine fitting. It is brought to a fit by pressure while running, then locked tight.

Yours truly  
R. N. MARTIN.

Renova, Pa.

#### Draining Main Reservoirs.

That water will accumulate in the main reservoir is certain; that it will find its way back into the brake pipe is also certain, unless that reservoir is drained frequently.

We are now at that season of the year when water in the brake pipe is a dangerous thing on account of possibility of freezing. Therefore, drain your main reservoirs often; and before leaving the round house disconnect the hose between the engine and tender and blow them out thoroughly. Some engineers even occasionally while on the trip open the tender drain cock during extreme cold weather.

#### Joint for Air Pump Pipes.

Editor:

I send a print of a joint we use on our air pumps. It can be used on the

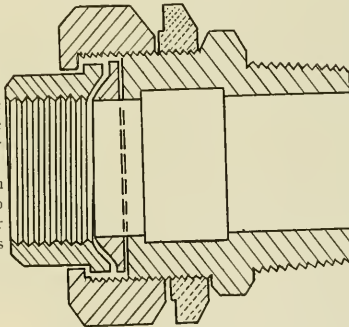

LOCK NUT ON PUMP CONNECTION

exhaust air discharge of the 9½ pump and the reservoir connection. No change required except concaving the swivel. This joint securely tightened and locked with the jam nut will stay.

Yours truly,  
R. N. MARTIN.

Renova, Pa.

#### Air Brake 1906 Proceedings.

One of the best proceedings yet published by the Air Brake Association is that which records the work done at the convention held in Montreal last June.

At this convention papers were presented that covered in a most thorough manner all the latest developments in the air brake art.

The subjects treated in the papers and discussed by the members include the Westinghouse new engine and tender equipment, familiarly known as the

E T, the latest improved triple valves including the "K" types, brought out by this company for both steam and electric traction road service, and the New York new engine equipment. There is also a paper on "Recommended Practice."

The papers are complete, and the various devices considered are fully illustrated by sectional, half tone, and diagrammatic drawings, which together with the piping diagrams, the discussion by the authors and the members, and the glossary of electrical terms, make the book one that is fully up to date, and that should be in the air brake library of every steam road and traction road air brake man who wishes to keep abreast of the times.

The whole is printed on first quality white paper, and it is bound in both leather and paper covers. The proceedings are now ready for distribution and may be had by addressing Mr. F. M. Nellis, Secretary of the Association, 53 State street, Boston, Mass., or by sending your order to this office. Price, leather bound, \$2.00; paper bound, \$1.50.

The Pneumatic Tool Company, of Chicago, make an air motor for turntables. The 1906 model contains some improvements on the old style. This new device places no strain on the turntable. If conditions exist whereby more traction is required, it can be got by placing the locomotive on the table to impart the desired traction. The motor is provided with universal swing and double flanged wheel, therefore it is easily accommodated to any kind of turntable pit rail. The motor will operate on a minimum air pressure of five pounds. When the motor is adapted to geared hoisting machinery or is used for similar duty, provision is made for holding the load under all conditions, including the bursting of hose or other cause, which may deprive the motor of air under pressure. Write direct to the company for further information if you are interested.

Towards the end of last month the Canadian Northern Railway instituted a daily passenger service on the new James Bay Railway, between Toronto and Parry Sound on the Georgian Bay. The distance between these points by rail is about 150 miles. The road has not been opened as the James Bay Railway, by which name it was generally known, but as the Canadian Northern Ontario Railway. This latter named was adopted when the Mackenzie & Mann interests decided to consolidate their various lines. Mr. C. W. Spencer is General manager of the road; Mr. F. M. Spidal, superintendent, and Mr. W. H. McEwan is train dispatcher.

### Repairs to Steel Cars.

As an example of what steel cars will stand in a wreck, Mr. J. F. MacEnulty showed some pictures to the members of the New England Railroad Club not long ago. The pictures were of a railroad wreck and the seven cars concerned were steel hoppers containing each fifty tons of ore and they ran three miles down a 4-per cent. grade and with the engine jumped over the end of a switchback. The cars and engine went 422 ft. clear before striking the earth again, and made a drop of 53 ft. They then rolled 516 ft. The original cost was \$1,200 per car. The repair charges amounted to \$690 each. Eliminating the repair cost of the trucks, which owing to the character of

ingenuity or confidence he should be sent to Altoona or Mount Clare or Colliwood, where they are past masters in the art of steel car repairs.

In the early days of steel car repairs it was the custom, when a sill was bent, to take the piece out and straighten it. Now an oil furnace or a charcoal fire under the car and a pulling jack applied to suit conditions is all that is needed. When sills are broken a splice can be made with a butt joint and plates inside and out, all securely riveted. Wrecked steel cars seldom have parts lost, so it is simply a matter of cutting off bent small parts, straightening them and riveting them in place. It is, however, advisable when buying new steel cars to get a

off the bent parts, straightening and re-riveting in place, the only new material being the rivets. A steel car having been in a wreck which would totally destroy a wooden car can be repaired for an average cost of \$50.00. A steel hopper so badly wrecked, that the advisability of scrapping it was considered, cost for repairs \$160.00. When it comes to the care of steel cars "an ounce of prevention is worth a pound of cure." At a prominent repair point, where 500 cars per month are repainted, the average cost for gondola and hopper cars is as follows: Sand blasting, 45 cents; paint for body and lettering, \$6.00; labor for body lettering, according to locality from \$1.00 to \$2.00. These figures do not include the trucks.

The fact of fewer repairs and less damage in wrecks is a potent argument, much used by steel car builders and agreed to by railway men, yet if there had not been so great a demand for increased loads, the steel freight car pioneers would have had a sorry time. In passenger car construction the question is different. If there are more passengers it means more cars. For high speed service it is practically essential to use a steel car, if the safety of passengers is desired. The splinters from old wooden war ships in time of action killed more men than the cannon balls. In steel cars, the passengers in an accident may suffer contusions, but that is cheaper from a claim department standpoint than an amputated limb, and passengers are not likely to be caught in the wreckage as they are in splintered and broken wooden cars and there is little chance of fire.

Aside from the question of accidents steel passenger cars should be a good investment. Running repairs are less, and the car is out of service a shorter time when going through the renovating process than a wooden car, the steel surface is easier to finish than wood is, and it does not require so much care. Car builders to get the cost and weight of a steel passenger coach or an interurban car, very close to that of a wooden car, built to the same specifications. This is a decided advantage, as railways may thus obtain an absolutely non-combustible car of much greater strength plus longer life, for a small additional outlay.

Mr. MacEnulty, speaking of a car built for the Philadelphia Rapid Transit Company, said the design is of steel throughout, with non-combustible flooring composition, and it is to all intents, shock and fireproof. The outside sheathing is of cold rolled steel and the under frames consist of deep fishbelly side sills with cross-bearers and connections in girder form. As an illustration of how this type of car will

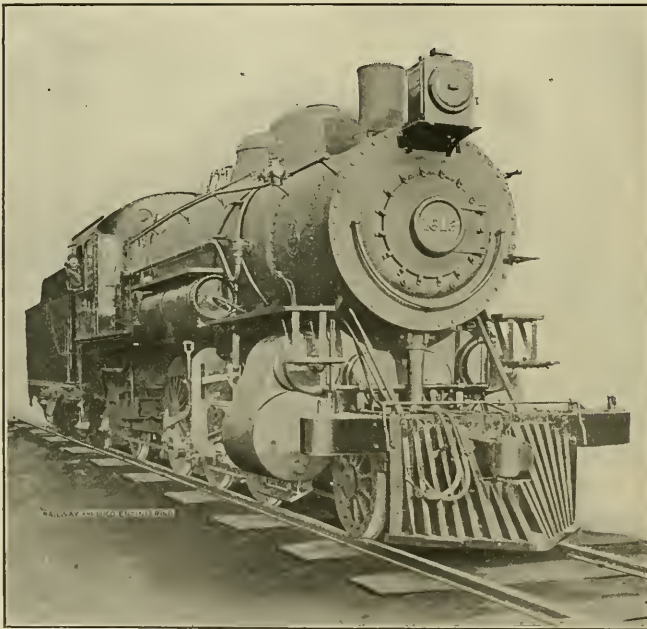

HEAD-ON VIEW OF BALDWIN COMPOUND FAST FREIGHTER

the wreck was heavy, the bodies cost \$350 each. In all about 68,800 lbs. of new material was used. A wooden car under such circumstances would only have been good for firewood, and this wreck, in which such an extraordinary leap was made, was perhaps as severe treatment as cars ever experience, goes to prove that a steel car is always good enough to repair.

There is absolutely no need, said the speaker, for any railroad to employ skilled labor in repairing steel cars or of returning them to the manufacturer. Skilled labor is not used where they were built, then why use skilled labor to repair them? Railways are now using the same repair gangs for both wood and steel cars. If a car foreman lacks

small supply of shapes likely to be needed for running repairs. This saves time and inconvenience no matter what arguments may be advanced for buying in the open market when they are needed. It may then be hard to get prompt delivery or harder to shape parts to suit.

The average cost of repairing steel cars varies considerably with the type. Taking the 100,000 lbs. capacity steel hopper car the average repairs to one end having side and end sills, draw sills, and corner braces and brackets badly bent is about \$36.50. With both ends damaged as above and body badly sprung the average repair cost is \$85.75. To cut entire frame and body apart and re-rivet, on the average \$140.00. This is the labor charge for cutting



behave in an accident, photographs were shown. The flat car upon which it was loaded jumped the track and overturned, carrying the passenger car with it. The advantages of the under frame construction with corrugated sheets under the monolith floor, were pointed out and the only damage sustained was a few broken windows and scratched varnish. A wooden car under similar conditions would have been badly damaged.

#### Baldwin Balanced Compound.

The Baldwin Locomotive Works have recently delivered to the Atchison, Topeka and Santa Fe Railway, 56 compound locomotives of the 2-6-2 type, one of which we illustrate. They possess a number of interesting features. They have a tractive power of 37,840 lbs. working compound. As the weight on

having both arms pointing downwards. The bearing for this rocker shaft is mounted on a frame-cross-tie, which is supported by knees bolted to the engine frames. It is also braced to the cylinder casting.

The Rushton trailing truck is used, the journals being placed outside. The spring seat is in the form of a cast steel saddle, which is suspended directly on the swing links. The spring link seat at the back of the truck is bolted to an outside supplemental frame, which is secured to the main frame by means of steel castings.

The wheel base of this engine is in all 33 ft. 9 ins. The rigid wheel base is 13 ft. 8 ins. and all the wheels are flanged. The total wheel base of engine and tender is 64 ft. 7½ ins. The weights carried on the leading and trailing truck are 31,300 lbs. and 42,200 lbs. respectively

has an inside diameter of 31½ ins. The Vauclain triangular welt is used under the dome, and the seam which is on top is welded. The crown sheet and the roof sheet both slope up toward the forward end.

This engine has a heating surface, of 4,017.8 sq. ft. in all, made up of 3,810½ in the tubes and 207.3 in the fire box. The total heating surface may be easily pictured by those who are familiar with a baseball field. The heating, absorbing surface of this engine is nearly equal to half the space enclosed between the lines joining the bases on the regulation "diamond" field. The grate area is 53½ sq. ft. and the ratio between grate and heating surface is therefore as 1 is to 74.9. The tubes number 342 in all and are 2¼ ins. diameter, No. 11 B. W. G. and each is 19 ft. long. If all the flues were put in line one in front of the

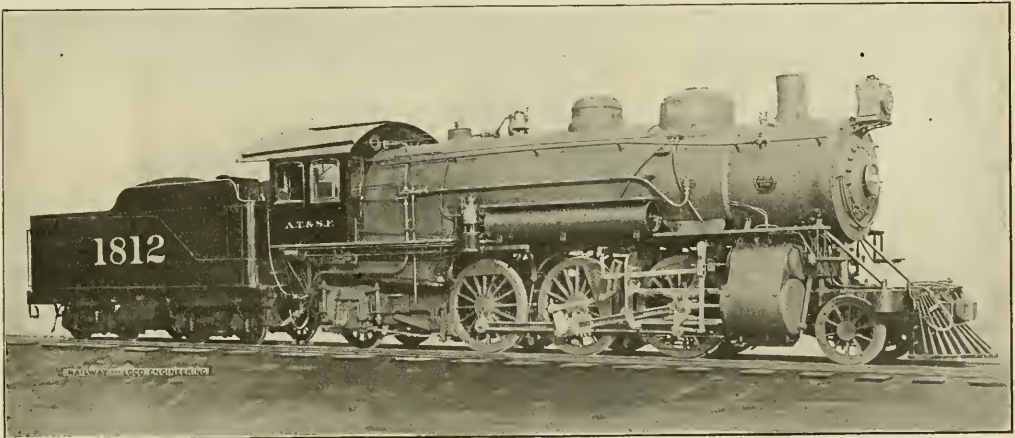

FOUR CYLINDER BALANCED COMPOUND FOR FAST FREIGHT—A. T. & S. F.

A. Lovel, Superintendent of Motive Power

Baldwin Locomotive Works, Builders

the driving-wheels is 174,700 lbs. the factor of adhesion is 4.61. These engines are intended for fast freight service. The cylinders are 17½ and 29 by 28 ins. and the driving wheels are 69 ins. outside diameter.

The pistons are all coupled to the second axle which is the main driving one, and the inside or high pressure cylinders are inclined at an angle of 7° so that the main rods can clear the leading driving axle. The two cranks on the same side of the engine instead of being placed 180° apart, are 173° apart; this arrangement is necessary on account of the inclination of the high pressure cylinders, in order that the pistons may start their strokes at the same instant. The front of these cylinders are 4½ ins. higher than the back.

The Walschaerts valve gear has been applied to these engines, the piston valves being driven by a rocker shaft

and with the figure already quoted for the adhesive weight, the total weight of the engine itself is 248,200 lbs. When the weight of the tender is added the grand total becomes about 418,000 lbs. This is the heaviest six-coupled locomotive, so far, built at the Baldwin Works. The spring gear for the drivers are all overhung and the driving wheels are spaced 82 ins. apart. The headlight glass of this engine is provided with a metal shield so that it may be completely obscured when standing in a siding waiting to meet another train.

The boiler is of the extended wagon top, radial stay type, the front ring of the barrel being coned. It is 76 ins. outside diameter at the smoke box end, and the inside diameter of the dome ring is 82 ins. The boiler has a sloping throat and back head.

The opening in the second course for the dome is 25 ins. and the dome itself

other they would make nearly 1¼ miles of tubing.

This boiler carries a steam pressure of 225 lbs. per sq. in. There is a relief valve placed on the smoke box, just behind the smoke stack and this valve opens directly into the tee pipe. When the engine is drifting, air passes into the dry pipe and so to the valve chambers and to the cylinders. The tender has a steel frame. The tank contains 9,000 U. S. gallons of water and holds 12 tons of coal. The service for which this engine is intended is fast freight and 16 degree curves will be encountered, and grades ranging from ⅝ per cent. to 1¼ per cent. Some of the principal dimensions are as follows:

Boiler—Thickness of sheets, ¾ in. and 29/32 in.; working pressure, 225 lbs.; fuel, soft coal; staying, radial.  
Fire Box—Length, 108 1/16 ins.; width, 71¼ ins.; depth, front, 83½ ins.; back, 70¼ ins.; thickness of sheets, sides, ¾ in.; back, ¾ in.; crown, ⅝ in.; tube, 9/16 in.; water space, front, 4½ ins.; sides, 5 ins.; back, 4 ins.

Driving Wheels—Journals, main, 11x10½ ins.; others, 10x12 ins.  
 Engine Truck Wheels—Front, diameter, 42¼ ins.; journals, 6½x12 ins.; back, diameter, 50 ins.; journals, 8x14 ins.  
 Tender—Wheels, diameter, 34¼ ins.; journals, 5½x10 ins.

Patent Office Department.

PROVING VALVE FOR BRAKE TEST.

An improvement in the means of ascertaining the condition of the brake system, and also the signal system throughout the entire length of the train, is coming prominently into notice. It is the invention of Mr. Geo. S. Hodgins, of the editorial staff of RAILWAY AND LOCOMOTIVE ENGINEERING. Pat-



AIR BRAKE PROVING VALVE

ent No. 602,009. The device, as shown in the illustration, combines a proving valve having air pressure pipes and couplings, one of which communicates with a chamber in a valve casing, a piston in the chamber which controls an opening from a second chamber which communicates with the other pipe coupling. The idea is that this device, when applied at the rear of a passenger train, has one hose coupling attached to the air brake pipe and the other to the signal system. Both rear angle cocks are opened and air from brake pipe and signal system enters separate chambers in the proving valve. There is no communication between the two, but when brakes are applied, a piston, similar to that used in a plain triple valve, moves and opens a port in the signal system, and by allowing a little air to discharge, causes the whistle

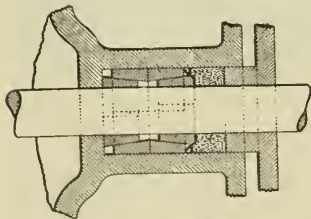

STUFFING BOX PACKING

in the cab to sound. This proves to the engineer that all the angle cocks on both brake and signal systems are open all through the train. The device is intended for terminal test, but may be used on the road.

STUFFING BOX PACKING.

Mr. S. M. Guss, Reading, Pa., has patented a stuffing box packing. No. 833,962. It comprises a clamping ring having an oppositely flared opening, a pair of split packing rings of conical form arranged with their smaller ends

contiguous and forming between them an annular lubricating chamber and with their larger ends projecting oppositely through the clamping ring, and means for pressing together the packing rings, the porous material of the clamping ring enabling the operating medium under pressure to occupy the annular lubricating chamber.

EXHAUST MECHANISM.

Mr. G. J. Hatz, Bloomington, Ill., has patented a locomotive exhaust mechanism. No. 832,858. The mechanism consists of a boiler portion provided with a smoke box, a main stack portion over the smoke box, a secondary stack centrally placed therein and providing one or more draft compartments between it and the main stack, a petticoat portion depending into the smoke box forming a continuation of the main stack and provided with a flaring por-

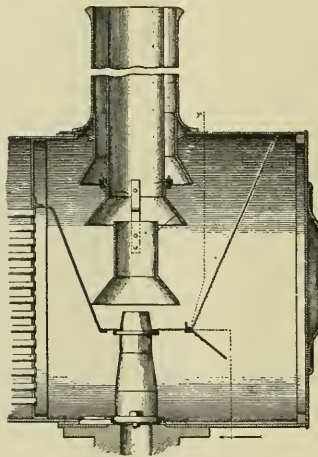

EXHAUST MECHANISM

tion at its lower end. There is also a hollow steam jet ring surrounding the secondary stack portion provided with a plurality of nozzles which are supplied with live steam from the steam channel of the locomotive engine cylinders. The device is claimed to create a rapid and efficient draft.

TRACK SANDER.

A track sander has been patented by Mr. F. B. Corey, Schenectady, N. Y. No. 834,108. It comprises a sand-trap, a sand supply opening for admitting sand to the trap, a sand delivery opening for conducting sand from the trap, and means for directing a broad, thin stream of air against the under side of the sand in the trap. A blast nozzle and a cap located over the nozzle for directing the air issuing from the nozzle complete the apparatus. The contrivance has been assigned to the General Electric Company, of New York.

BOILER JACKET.

A jacket for steam boilers has been patented by Mr. J. Fischer, Swanton, Ohio. No. 832,785. It comprises a heat insulating inner covering having a direct contact with the outer surface of the boiler, a metallic outer covering with longitudinal strips of insulating material interposed and spaced apart

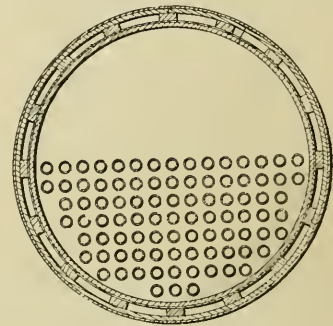

BOILER JACKET

to form coextensive longitudinal air spaces, with a series of retaining bands severally surrounding the various sections of the outer covering.

JOURNAL BOX.

Mr. J. S. Patten, Baltimore, Md., has patented a journal box. No. 833,695. It is of the usual outward structure having inwardly directed portions extending slantingly from its sides downwardly in the direction of the journal in the box above the space to be packed with waste; the slanting portions extend continuously from end to end of the box with their lower portions in close proximity to the journal and spaced downwardly from the line of the bottom of the brass to receive oil from the brass and direct it and discharge it to the waste adjacent to the journal.

PERMANENT WAY TREATMENT.

A method of treating the surface of the permanent way of railways has been patented by Mr. H. E. Harwood, Jolimont, Australia. No. 832,973. The



TREATMENT OF PERMANENT WAY

purpose is to prevent weedy growths thereon, and consists in the employment of a locomotive machine which sprays finely disseminated arsenic and tar in a heated condition upon the ballast and sleepers, applying a layer of sand or pulverized earth upon such sprayed surface for drying purpose. There is a tar supply tank, means for heating the tar, a spraying device, and a locomotive for conveying the parts and shields for protecting the rails.

### Electric Traction on the N. Y. C.

What is commonly called the Electric Zone on the New York Central is at present the line from the Grand Central Station to Wakeheld on the Harlem division, a distance of 13 miles, and from Mott Haven to Kingsbridge on the main line, 4 miles, making a total of 17 miles. The electric zone will eventually be extended on the main line to South Croton and on the Harlem,

current is withdrawn and the battery brought in circuit. The battery in its charged condition is a storehouse of power just as coal on a locomotive tender is. There the carbon of the coal is ready to re-combine with the oxygen of the air when the appropriate conditions are secured in the fire box. The storage battery, like the coal, possesses what is called the potential energy of chemical separation. The chemical

and the shoe next the platform is covered up under the overhanging dummy and out of the way of the curious passenger or would-be experimenter among the traveling public.

The rolling stock immediately concerned in the electric traction scheme are 35 locomotives weighing each about 100 tons and having a normal capacity of about 2200 h.p. These have already been illustrated and described in the columns of RAILWAY AND LOCOMOTIVE ENGINEERING. These locomotives will haul the coaches of the through trains for the present, between the Grand Central Station and Kingsbridge. These coaches being heated with steam, the electric locomotive is equipped with a small boiler similar to that used in a Whyte automobile, which will supply the necessary heat. The air brake is supplied by an electrically driven air pump on the engine. The coach lighting system of the trains not being dependent upon the locomotive, will not be effected by the change.

In addition to the electric locomotives for through train service, the company has 125 all-steel multiple-unit motor cars for suburban service each with a normal capacity of 400 h.p. and weighing each about 53 tons. There are 55 all-steel multiple unit trailer cars for suburban work, each weighing about 41 tons. Six all-steel multiple unit motor combined baggage and express cars each of 400 h.p. capacity, complete the equipment, which makes in all 221 vehicles for exclusively electric operation.

Among the improvements which come in with the electrical transportation of the metropolitan terminal of the New York Central is a change from left hand to right hand running and the placing of signals on the right side of the track, in conformity with the general practice all over the system. A shortening of the main line by 4,013 ft. will be effected, 75 miles of new track will be laid, 43 miles of new yard track will appear and 8 miles of passing tracks will be put down, making a total of 126 miles. The existing signal system, which is principally manual-controlled and electro-pneumatic automatic, will be replaced by new all-electric automatic signals and interlocking plants. This will require the use of alternating current for track circuits, while the propulsion system by which the locomotives and motor cars are driven, is direct current.

We have received from the office of the Scientific American a copy of the catalogue of Scientific and Technical books published by Messrs. Munn & Co., of New York. There are 92 pages in which the names of the books appear with a short explanation of the scope and purpose of each book. The catalogue is sent free by them.

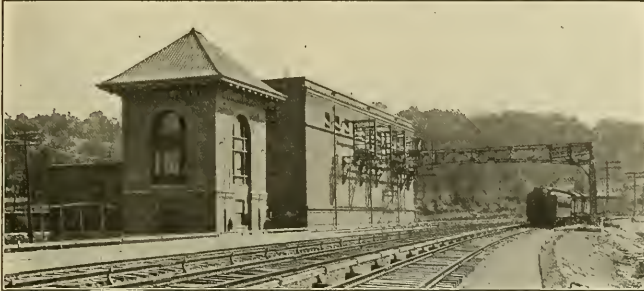

SUB-STATION, TRAIN, TRACK AND THIRD RAIL ON THE N. Y. C.  
(Courtesy of Street Railway Journal.)

to North White Plains, and when this is done there will be 52 miles under electric traction. The track mileage including yard tracks now amounts to 85 miles, but when the extension of the electric system is completed there will be 292 miles in all. The rails weigh 100 lbs. per yard.

The power house is at Port Morris and at that point electricity is generated as an alternating current, at 11,000 volts pressure. This current is carried to four sub-stations; No. 1 at the Grand Central Station, No. 2 is at Mott Haven, No. 3 at Kingsbridge and No. 7 at Bronx Park. These four constitute the present equipment. Nos. 4, 5, 6 and 8 will be at Yonkers, Irvington, Ossining and Scarsdale, respectively. Speaking generally one may say that the current from the main power house reaches the sub-stations north of Mott Haven by overhead cable lines and southward by cables enclosed in conduits. At the sub-stations, the alternating three-phase current is transformed to direct current at 666 volts, which is supplied to the third rail in that form for use by the electric locomotives.

At each sub-station there is an auxiliary storage battery equipment. The storage battery installation is intended to supply current in case of any serious derangement taking place at the central power station. The theory of a storage or secondary battery is that by passing into it a certain amount of what may be called surplus current, the chemical constituents of the battery are separated and stand ready to reunite again as soon as the charging

current of the separated elements of the battery in a manner similar to the chemical transformation effected by the combustion of the coal, gives back, with certain necessary losses, the power which was originally supplied to it and in emergency this can be used for propulsion.

The third rail is what is called an under contact protected working conductor. That is, it is suspended from arching brackets or supports which stand on the ties. These are in shape something like an inverted letter J, and at each bracket the third rail is enclosed in a porcelain insulator. The upper side of the rail is covered with wood for the protection of track men and others. The contact shoe on the electric locomotives slides along the underside of the third rail, and is held up against it by spring pressure of about 50 lbs., which would not be sufficient to lift even a yard of the 70 lb. third rail.

The third rail arrangement in the Grand Central Station has been devised with a view to safety. It is, as we have said, protected by a covering of wood on top and along the outer edge and is placed on the side of the track, remote from the passenger platforms. As the contact shoes of the locomotive projects from each side, the shoe which passes along close to the platform edge, in the station, runs under a dummy third rail composed entirely of wood and which the shoe does not touch. When an electric locomotive stands in the station, the contact shoe touches the live third rail on the side farthest from the platform

### Inspection During Manufacture.

Kipling described an old overloaded undermanned ship, the "Boliver," as "just a pack o' rotten plates puttied up with tar." Well that is not exactly the length Mr. T. S. Griffiths went when speaking, among other things, of the inspection of locomotives during the process of manufacture; to the Canadian Railway Club a short time ago. He went this far however, he said that from the flanging of the heads to the final touching of the machine, no detail may be overlooked, no workman marked trusty, else a plug-putty or even dirt may cover a radical or possible wrong which may cause enormous financial loss or even life itself, yet not with criminal intent, but more often through lack of thought or ignorance of careless employees, which manufacturers are forced to employ to make deliveries, to fill out gangs through lack of experienced thoughtful machinists.

If a flanged plate should be overheated minute cracks may appear, unknown to workmen, which only an inspector or trained boilerman may know and see. The inspector has to be on the alert, watching the assembling of the parts so that some tired workman may not make one or two drift pins pull together what 12 to 20 pins should do, and also to see that the metal around the holes is not distorted, and that holes match evenly so as to avoid slotting when reamed, and fractures at joints.

In the matter of cylinder castings experience is needed to know the proper density of metal whether so porous as to wear quickly or too hard, and that no cement or plugging is used. It is often left to the inspector to see that lubricators and other things are not placed so that they cannot be operated. Tanks insufficiently braced are often supplied with extra braces at the suggestion of the inspector. In every detail, from cauterizing valves to the burnishing of machine work and of the adjustment of every key, set screw and nut, nothing can be omitted which goes to form a smooth, harmonious working mechanism which shall be a pride to the builder, the purchaser and the inspector.

Speaking of the inspection of cars during the process of manufacture Mr. Griffiths alluded to several things in the inspection of cast iron wheels which an inspector must look out for. Where foundrymen had some doubt about their wheels they might during the thermal test make a shallow space around the tread so that the amount of hot metal poured around the tread would be less than the prescribed amount and thereby the wheels would be subjected to a milder test than that intended by the M. C. B. specification.

It has been known that wheels have been reannealed or have been put into pits a second time with hot wheels, so as to bring them up to the standard tape size. This is not legitimate, and it is an inspector's duty to see that this kind of thing is not done.

Car manufacturing concerns are sometimes inclined to deal severely with an inspector for being too rigid in his inspection and frequently say to him that if the railway officials were there to see some of the work or material which the inspector has condemned it would be all right. This means that the inspector should have a thorough knowledge of the material he is inspecting and be able to hold his end up. As an example he mentioned the case of an inspector who was denounced as too severe by a manufacturer, but when the work was completed and a congratulatory letter was sent from one of the railway officials to the manufacturer, the firm had to admit that rigid inspection was a good thing all round.

Record of recent Construction, No. 59, has been issued from the Baldwin Locomotive Works containing valuable information pertaining to a great variety of locomotives, accompanied

were built for the Western Maryland Railroad Company. These fine engines are adapted for a maximum grade of 156 feet per mile for ten miles, and with full equipment weigh about 150 tons. They are also equipped with the Walschaerts valve gearing, the parts being furnished with very broad and ample bearings. A copy of this record of construction may be obtained by writing for one direct to the Baldwin Works.

### Superheaters in Prussia.

The Department of Public Works in Prussia has called the attention of the several railways to certain defects which have appeared in the locomotives furnished with superheaters, and has suggested means to remedy the defects. It has been found that in the steam boxes of the Schmidt superheater the projecting ends of the steam tubes rust easily and rapidly weaken, with the result that the crown plates of the superheating chamber become distorted and leak. Drainage channels have been tried with valves opening into the steam box, and these valves open automatically by the action of spiral springs when the steam pressure is shut off. The effect of the drainage



N. Y. C., SUB-STATION NO. 3, SHOWING POLE AND OVERHEAD CONSTRUCTION  
(Courtesy of Street Railway Journal)

with illustrations beautifully executed on cream finished paper. The locomotives are presented without special arrangement and mainly in the order of construction. They range from the heavy type of Pacific locomotive of nearly 200 tons, to the light six-coupled double-ender locomotive of 80 tons. A fine type of freight engine is shown of the 2-8-2 type locomotive, furnished with Walschaerts valve gearing, and guaranteed to draw 250 net tons up a 4 per cent. grade with 10 degrees curves. Another fine type is the Ten-Wheel Locomotive, a number of which

valves has also been to maintain the strength of the plates.

All business men having need to find the names of foreign railway officials ought to have on hand a copy of the Universal Directory, published in London. The latest issue is large and very correctly compiled. This directory has the reputation of containing a correct list of all railway officials in every country in the world; also the mileage, gauge and equipment owned by the different lines. Full information by Mrs. A. Fenton Walker, 143 Liberty St., N. Y.

# Of Personal Interest

Mr. W. Scubblebine has been appointed manager of the Refined Iron and Steel Company, at Pittsburgh, Pa.

Mr. J. A. Green has been appointed Acting Chief Engineer of the Montana Railroad, with office at Helena, Mont.

Mr. A. E. Bachert has been appointed Chief Engineer of the East Broad Top Railroad, with office at Robertsdale, Pa.

Mr. W. T. Perry has been appointed foreman of the Union Pacific Shops at Cheyenne, Wyo., vice Mr. E. F. Fay, promoted.

Mr. O. H. Reynolds, heretofore editor of the Railway Master Mechanic, has severed his connection with that publication.

Mr. H. J. Trein has been appointed master mechanic of the Denver, Enid & Gulf, at Enid, Okla., to succeed Mr. John Rohrig.

Mr. E. F. Fay has been appointed general foreman of the Union Pacific Shops at Omaha, Neb., vice Mr. H. Stovel, promoted.

Mr. C. F. Rydberg has been appointed superintendent of Angus Car Shops of the Canadian Pacific Railway, in Montreal.

Mr. J. McNaught has been appointed Superintendent of the Montana Division Great Northern Railroad, vice Mr. C. O. Jenks resigned.

Mr. F. A. Smock has been appointed Master Mechanic of the Pennsylvania Railroad at Meadows, N. J., vice Mr. J. W. Sanford, retired.

Mr. Chas. Hay has been appointed road foreman of engines of the Mexican Central Railway, with headquarters at Chihuahua, Mexico.

Mr. E. Krouse has been appointed foreman of car inspectors in the Pennsylvania shops at Sunbury, Pa., vice Mr. C. S. Kessler promoted.

Mr. A. W. Whiteford has been appointed superintendent of the Lehigh Valley Railroad shops at Sayre, Pa., vice Mr. E. T. James, resigned.

Mr. L. M. Shipley has been appointed Superintendent of Terminals of the Chicago Great Western Railway, at Oelwein, vice Mr. Wm. Matthie, resigned.

Mr. E. J. Bouchard has been appointed superintendent of motive power and rolling stock of the Sierra Railway of California, with headquarters at Jamestown, Cal.

Mr. F. H. Worthington, superintendent at Decatur, Ill., has been appointed Superintendent of the Vandalia at Logansport, Ind., vice Mr. I. W. Geer, transferred.

Mr. Allan McDuff, general foreman of the Chicago, Rock Island and Pacific Railway shops at Cedar Rapids, Ia., has been elected a supervisor of Linn County, Ia., and will quit railroad work. Mr. McDuff although a man under sixty has been the oldest employee in the Mechanical Department at Cedar Rapids for many years. He learned the machinist trade in the famous Shanks Tool Works at Johnston, Scotland, and came to this country shortly after finishing his apprentice-



ALLAN McDUFF

ship. He went to work in the shops of the Burlington, Cedar Rapids and Minnesota Railway about 1872 and was one of a small group of mechanics who clung to the misfortune of the railroad through years when the visits of the pay car were few and far between. Allan was always ready to help in emergencies and was equally at home fitting up a set of links, curing a sickly air pump, running a locomotive or sketching a design for the pattern maker. When hot air engines and gas engines were first put into service at pumping stations Allan McDuff was the only man on the road that could remedy the defects when they stopped working.

The Westinghouse Air Brake was a great puzzle to mechanics at first, but Allan found a sectional illustration and

description of this invention in a cyclopedia and taught the men in the shop how repairs should be made. He gave Angus Sinclair his first lesson on the air brake and many a pleasant evening they spent together talking on their favorite theme. On the wife of one of these men being asked by a friend, "What do those men get to talk about night after night?" she promptly replied, "air brakes."

Allan has always been an industrious student of mechanical appliances and problems and there is scarcely any kind of mechanism that he does not thoroughly understand. He is the kind of man who is kept from promotion because he is too valuable a man in, say, the tool room. Mr. McDuff would have made an admirable master mechanic for a road where personal energy, push and good management had to overcome the shortcomings of poor tools and inferior facilities. The writer repeatedly obtained the offer of positions for Mr. McDuff as master mechanic, some of them on good roads, but he would not leave Cedar Rapids, where his thrift and good management had accumulated considerable property. To write these lines is a labor of love, for it gives a small meed of praise to one who constitutes genuine salt of the earth.

Mr. C. S. Kessler, foreman of car inspectors in the Pennsylvania shops, at Sunbury, has been promoted to assistant to the general car inspector at Williamsport.

Mr. S. A. Nicholas has been appointed superintendent of the Missouri and North Arkansas, with headquarters at Eureka Springs, vice Mr. O. Man, resigned.

Mr. W. E. George, Master Mechanic at Needles, Cal., has been transferred as Master Mechanic on the A. T. & S. F., to Winslow, Ariz., vice Mr. H. G. Wall, transferred.

Mr. J. B. Sucece, trainmaster at Lafayette, Ind., has been appointed General Superintendent of the Chicago, Indianapolis and Louisville, vice Mr. G. K. Lowell, resigned.

Mr. Hamilton Stovel, formerly general foreman at Omaha, Neb., has been appointed superintendent of shops of the Union Pacific Railroad, vice Mr. A. W. Whiteford, resigned.

Mr. O. G. Eubanks, formerly Chief Car Inspector at Albany, Ga., has been promoted to be Chief Traveling Car Inspector of the Second Division of the Atlantic Coast Line Railroad.

Mr. R. F. Tync, locomotive foreman at Brandon, Man., has been appointed Master Mechanic of the Canadian Pacific Railway, at Moosejaw, Sask., vice Mr. W. E. Woodhouse, transferred.

Mr. G. C. Starrow, for some time one of the assistants to the foreman of the Pennsylvania Car Shops, has been appointed general foreman of car inspectors on the Sunbury division.

Mr. H. G. Wall, formerly Master Mechanic at Winslow, Ariz., has been appointed master mechanic at Needles, Cal., on the Atchison, Topeka & Santa Fe, vice Mr. W. E. George, transferred.

Mr. C. J. Kelloway, hitherto supervisor of interlocking on the Delaware, Lackawanna & Western, has been appointed signal engineer on the Atlantic Coast Line, with office at Wilmington, N. C.

Mr. J. B. Kilpatrick has been appointed Superintendent of Motive Power of the Chicago, Rock Island and Pacific Railroad with office at Chicago, vice Mr. L. W. Harrison, resigned.

Mr. C. L. Acker, roundhouse foreman of the Baldwin Locomotive Works at Philadelphia, Pa., has been appointed master mechanic of the Toledo Railway and Terminal Company at Toledo, Ohio, vice Mr. A. J. Ball, resigned.

Mr. P. T. Dunlop, heretofore division master mechanic of the Gulf, Colorado and Santa Fe at Temple, Tex., has been appointed mechanical superintendent of the same road, with headquarters at Cleburne, Tex., vice Mr. A. Harrity, resigned.

Mr. Wendell P. Colton, industrial agent of the Lackawanna, who has been in hospital for some time, is now convalescent and his complete recovery is believed to be assured. Mr. Colton's many friends will welcome him back to his accustomed place.

Mr. Walter Byrd has been appointed General Foreman of the Canadian Pacific Railway, at Revelstoke, B. C. Mr. Byrd has just returned from a trip to the coast, where he spent some time

Mr. Geo. H. Lickert is master mechanic of the Colorado Division of the Union Pacific Railway, at Pullman, Colo. By some mistake our printer got his name down as Pickett. The name is correctly spelled above. We apologize for the mistake and wish Mr. Lickert every success in his new field of work.

Mr. William Donald is master mechanic on the Rio Grande Western Railway at Salt Lake City, Utah. We understood that he had accepted a position with Missouri Pacific and so stated it. Mr. Donald, however, writes us that there is no truth in the rumor and that he is still doing business at the old stand, on the R. G. W. at Salt Lake City.

Mr. E. T. James, superintendent of the Lehigh Valley shops at Sayre, Pa., has resigned. Mr. James was formerly master mechanic of the company's shops at Buffalo. When the big plant at Sayre was built he was given full charge. He is recognized as a skilled and reliable man in railway mechanics

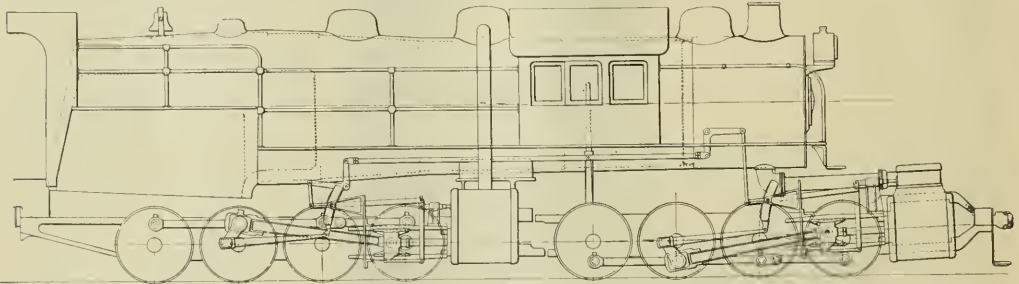

OUTLINE OF MALLET COMPOUND FOR THE ERIE RAILROAD

Geo. W. Wildin, Mechanical Superintendent

American Locomotive Company, Builders

Mr. M. J. Drury has been appointed Mechanical Superintendent of the Western Grand Division of the Atchison, Topeka and Santa Fe with office at La Junta, Colo., vice Mr. C. M. Taylor, resigned.

Mr. H. P. Timmerman, general superintendent of the Ontario Division of the Canadian Pacific Railway, has been transferred to Montreal as general superintendent of the Eastern Division of the same road.

Mr. James Osborne, general superintendent of the Eastern Division of the Canadian Pacific Railway at Montreal, has been transferred to Toronto as general superintendent of Ontario Division of the C. P. R.

Mr. W. J. Pamplin, formerly General Round House Foreman at South Rock Mount Shops, has been promoted to the position of Master Mechanic of the Atlantic Coast Line Railroad at Waycross, Ga., vice Mr. R. R. Young, resigned.

in rest and recuperation. He was formerly at Calgary, Ala.

Mr. Herbert Wilgus, formerly engineer of the Brooklyn Heights Railroad, has been appointed Chief Engineer of the Pittsburgh, Shawmut and Northern with office at Olean, N. Y., vice Mr. A. G. McComb, resigned to go into other business.

Mr. J. W. Duntley, President of the Chicago Pneumatic Tool Co., sailed for Europe November 6, for a five weeks' trip in the interest of the company's business, during which time he will visit the important trades, generally in England, Scotland, France and Germany.

At a meeting of the Independent Pneumatic Tool Company a short time ago the following officers were elected: President, Mr. John B. Brady; first vice-president, Mr. W. O. Jacquette; second vice-president, Mr. J. D. Hurlley; treasurer, Mr. C. E. Erikson; secretary, Mr. A. B. Holmes.

and a person of independent thought and action. His plans for the future have not been disclosed.

Mr. L. C. Fritch has been appointed Assistant to the President of the Illinois Central Railroad, with office at Chicago, Ill. In February, 1904, he entered the service of the Illinois Central Railroad, being engaged in special work for the Assistant General Manager. In 1905 he was appointed Assistant to the General Manager. Mr. Fritch was for several years Secretary of the American Railway Engineering and Maintenance of Way Association; he is also a member of the American Society of Civil Engineers.

The Ingersoll-Rand Company have just issued a finely illustrated Bulletin, No. 2008, showing a variety of their labor-saving tools operated by compressed air. All interested in motor hoists should apply to the Manager, Mr. C. H. Hasseler, 11 B'way, New York.

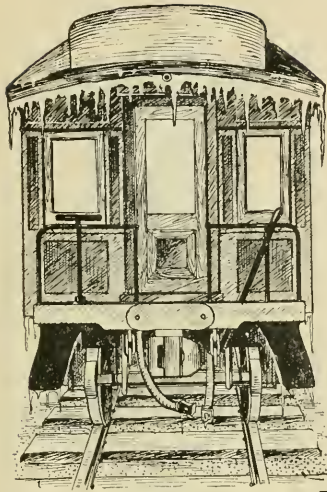

## The Cold Test

With the bleak, cold weather comes more or less imperfect action of the air brakes, and worry and trouble for the engineer as a result. If nothing is done to relieve this condition, you will be bothered all winter, and consequences may be serious.

When the air brake system is lubricated with Dixon's Graphite Air Brake and Triple Valve Grease the brakes respond sensitively to all reductions of pressure. Even in the coldest winter weather this grease will not stiffen and result in emergency action of the brakes when service application is wanted.

Get "proof" sample No. 69-I, and make some trial tests on your engineer's valve and angle cocks.

**JOSEPH DIXON  
CRUCIBLE CO.  
Jersey City, N. J.**

### Good Idea.

The Chicago Great Western has created an office, that of inspector of station service. The position has been filled by the appointment of E. H. Campbell, heretofore agent at St. Joseph, Mo. The inspector will keep the general superintendent informed about the condition and accommodations given the public at the various stations, and make such recommendations for their betterment as he sees fit.—*New York Commercial.*

### Erie Mallet Compounds.

The trio of Mallet articulated compound locomotives, recently ordered by the Erie Railroad, will be used as pushers on the grade east of Susquehanna, Pa. Locomotives of this type are still a novelty, but the few that have been built, though many tons lighter than these Erie whales, have given such good service as to practically place them at the top notch as heavy grade helpers. The American Locomotive Company, which is building them, gives the following dimensions: There will be 16 driving wheels four cylinders, the boiler will be over eight feet in diameter at its largest part and will contain 2¼ in. tubes to the number of 468, each 21 feet long, or more than a mile and three-quarters, if joined together all in a line. The driving wheels will bear all the weight of the engine, and thereby will be secured the advantage of every pound of adhesive weight.

These engines will greatly exceed the one on the Baltimore & Ohio, or the latest example in this country of the Mallet type of locomotive, the Great Northern engines, recently built by the Baldwin Locomotive Works, which were illustrated and described in our October issue, page 472.

The proposed design, which is here illustrated in outline, is for an engine weighing 410,000 lbs., with a tractive effort of 98,000 lbs. As the design of these engines is in the preliminary stage, very little can be given in regard to the details at this time. We expect to publish a full description of these monsters in the near future. A comparison of the principal dimensions with the Baltimore & Ohio and the Great Northern engines will be of interest:

	Road—Baltimore & Ohio.	Great Northern.	Erie.
Builder—Am. Loco Co.	Baldwin	Baldwin	Am. Loco Co.
Wheels, 0-6-6-0	2-6-6-2	0-8-8-0	0-8-8-0
Total weight, 334,500 lbs.	355,000 lbs.	410,000 lbs.	410,000 lbs.
Weight on drivers, 334,500 lbs.	316,000 lbs.	410,000 lbs.	410,000 lbs.
Size of cylinders, 20 and 32x32 ins.	21½ and 33x32 ins.	25 and 39x28 ins.	25 and 39x28 ins.
Diameter of drivers, 56 ins.	55 ins.	51 ins.	51 ins.
Tractive effort, 71,500 lbs.	71,600 lbs.	98,000 lbs.	98,000 lbs.
Steam pressure, 235 lbs.	200 lbs.	215 lbs.	215 lbs.
Total wheel base, 30 ft. 8 ins.	44 ft. 10 ins.	39 ft. 2 ins.	39 ft. 2 ins.
Driving wheel base, rigid, 10 ft.	10 ft.	14 ft. 3 ins.	14 ft. 3 ins.
Total heating surface, 5,585 sq. ft.	5,658 sq. ft.	6,108 sq. ft.	6,108 sq. ft.
Grate area, 72.2 sq. ft.	78 sq. ft.	100 sq. ft.	100 sq. ft.

### Sir Richard Tangye.

To the great regret of the engineering world and a wide circle of friends, Sir Richard Tangye, the eminent English engineer, died last month at Kingston, Surrey, England. He was 73 years of age. As a boy he was employed on his father's farm in Cornwall. Of a mechanical turn of mind, he secured employment in an engineering establishment in Birmingham. He began in a small way the manufacture of screw jacks, and was joined by his three brothers. Hydraulic jacks and presses were introduced by them, and the business grew rapidly. There are now over 2,500 men employed at the works of the Tangye Brothers. Richard was the engineer of the family, and some of his achievements brought the firm into great popular favor. Among them was the launching of the Great Eastern, which the builders had been unable to move for three months. Brunel, the eminent engineer, had failed to launch the great ship, and it had begun to sink in the ways when Tangye was called to assist, and with the use of a large number of hydraulic jacks the great ship was launched in a few days. The differential pulley block was also successfully introduced by the Tangyes. Four of their jacks raised Cleopatra's Needle on the Thames Embankment. A hydraulic shearing machine was introduced by them, cutting 6 in. bars cold. Screw cutting and other devices followed, and orders were filled for hydraulic machinery in every country in the world.

The city of Birmingham has been greatly benefited by the liberality of the Tangyes. They established the Municipal Art Gallery and School of Art, to which they contributed about \$150,000. In 1894 Richard Tangye was knighted by the late Queen Victoria in recognition of his public services. Sir Richard was a great traveler, being seven times in Australia, and his volume, "Reminiscences of Travel," has had a wide circulation. He was a Radical in politics, and his other published work, "The Two Protectors: Oliver and Richard Cromwell," showed that his political thought was largely inspired by the great Commonwealther.

### Stopping a Moving Train.

One and only one fundamental cause brings a moving train to rest; that is, friction. This friction is not confined to one place. There is friction between the moving parts of the train itself, friction between the train and the atmosphere, friction between the brake shoes and the wheels, and friction between the wheels and the rails. It is the friction between the wheels and the rails upon which they roll, that is the most important factor of all. These statements were made by Mr. S. W. Dudley in a most interesting paper read before the Western Railway Club not long ago.

In bringing out this latter point, the speaker referred to the usual expression, "The brakes stopped the train," and asked what would happen if the rails were made of ice? Would any amount of brake shoe pressure bring a train on ice rails to a stop quickly? A car wheel rolling on a rail has a point of contact which is, at the instant, at



GOOD LOOKING ROAD BED

rest so far as wheel and rail are concerned. The part of the tire surface, for the moment it is on the rail, is not moving with reference to the rail. This important point here comes in, that the friction which prevents the wheel sliding along the rail is not the friction of motion. It is the friction of rest. Between wheel and rail we have what is called static friction.

When we come to the friction between brake shoe and wheel, we have the friction of motion, or kinetic friction. This word comes from the Greek verb *kineo*, "I move," and there is a difference between the static or standing friction between wheel and rail and the kinetic or moving friction between shoe and wheel.

When we come to wheel sliding or skidding, we have both these kinds of friction to deal with. The brake shoe pressure, multiplied by the coefficient of the kinetic friction, gives the force acting to stop the rotation of the wheel. The weight on the wheel, multiplied by the coefficient of the static friction, gives the force resisting the tendency

to stop rotating or to slide. By increasing the brake shoe pressure we increase the tendency to stop rotation, and when we come up to the point where the wheel actually stops rotating, we change the static friction between wheel and rail into kinetic friction, as the locked wheel slides along. As the kinetic friction between wheel and rail is less than the static friction between them, the length of time required to make a stop, or the distance passed over in making a stop with skidded wheels, is greater than if the retarded wheels had been allowed to revolve.

For sake of example, suppose we have a car weighing 80,000 lbs., mounted on two four-wheel trucks. Each wheel supports a load of 10,000 lbs. An average value for static friction between wheel and rail under ordinary conditions is 0.20. It may run higher or lower, according to the state of the rail, but this is a fair average. Now, in the case of this car,  $10,000 \times 0.20 = 2,000$  lbs. This is the force which must be overcome if the wheel be made to slide. Now for the kinetic friction between shoe and wheel. At 60 miles per hour the coefficient of friction is about 0.07. Taking 90 per cent. of the light weight of the car as the maximum brake shoe pressure to be allowed, we have 72,000 lbs. distributed over eight brake shoes, or 9,000 lbs. on each shoe. With the coefficient of kinetic friction 0.07, we get a force of 630 lbs. retarding rotation of every wheel, and we have already seen that there is 2,000 lbs. per wheel acting to prevent each wheel being slid.

At first sight, this looks as if the brake shoe pressure could be considerably increased, but other conditions must be considered. The fact is now well established that the value of the coefficient of kinetic friction between shoe and wheel is different at different speeds. At 60 miles per hour it is about 0.07; at 30 miles per hour it is about 0.16; and at 10 miles per hour it is about 0.24. In the case before us, we had 630 lbs. retarding force on the wheel at 60 miles per hour. At 10 miles per hour, with the new value for the coefficient of kinetic friction, we would have  $9,000 \times 0.24 = 2,160$  lbs., which is more than sufficient to skid the wheels if the brakes were held tightly on. We may here observe that this fact, which Mr. Dudley so clearly brings out, viz.: the change in the value of the coefficient of kinetic friction due to difference of speeds is the principle which is relied upon in the application of the high speed brake.

Just here comes in a consideration of what Mr. Dudley called the "time element." Tests have demonstrated that this alteration in the coefficient of

# GOLD Car Heating and Lighting Co.

Manufacturers of

**ELECTRIC,  
STEAM AND  
HOT WATER  
APPARATUS  
FOR RAILWAY CARS**

**EDISON  
STORAGE  
BATTERY  
FOR RAILWAY CAR  
LIGHTING**

Largest Manufacturers in the World  
of Car Heating Apparatus

Catalogues and Circulars  
cheerfully furnished

Main Office, Whitehall Bldg.  
17 BATTERY PLACE  
NEW YORK



## JUST PUBLISHED

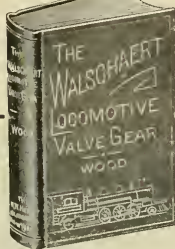

## The Walschaert Locomotive Valve Gear

By W. W. WOOD

Nearly 200 Pages. Fully Illustrated.

PRICE \$1.50

The valve gear is the principal, and most vital, of the parts of any engine, and the cumbersome and unwieldy Stephenson link motion that has been in general use in this country for over half a century is rapidly being displaced by the lighter, and more accurate, valve gear of the Walschaert type.

It required years of study and experience for many an intelligent man to gain merely a fair understanding of the principles of the common link motion, and now the locomotive engineer, the shop man, and the motive power official are being demanded to post themselves on the newly adopted Walschaert Valve Gear.

But it will not take years—nor months—to thoroughly understand the Walschaert valve motion if you possess a copy of this book. The author takes the plainest form of a steam engine—a stationary engine, in the rough, that will only turn its crank in one direction—and from it builds up a modern locomotive, equipped with the Walschaert valve gear, complete.

### This Book is Composed of Four General Divisions

The *First Division* explains and analyzes the Walschaert valve gear. There are no algebraical formulas in this Division—just plain talk.

In the *Second Division* the designing and erection of the Walschaert gear is treated from the viewpoint of the scientific engineer and master mechanic. In this Division is contained diagrams and formulae that will enable any machine shop foreman to design and lay out the Walschaert valve gear for any locomotive, with hints on inspection of the gear and rules for setting the valves. Here are two diagrams, in particular, on folding sheets, that show the position of the valve, link and all other parts of the gear, when the main crank-pin is at nine different points in its revolution—both with the outside admission D-slide valve and the piston valve of inside admission. Separate cardboard models of these two valves to be used in connection with the diagrams are contained in a pocket in the book, and these two diagrams and valve models, alone, are worth more than the price of the book to any master mechanic, shop foreman, machinist, engineer or fireman.

The *Third Division* has to do with the actual work of the Walschaert valve gear on the road, and here is disclosed the advantages obtained from its use and the reasons why it is superior to the common, double-eccentric link motion.

The *Fourth Division* is composed entirely of "Questions and Answers on the Walschaert Valve Gear," which form a condensed, but complete, set of instructions, with only descriptive of the valve gear, etc., but these questions and answers also refer to all of the common breakdowns on the road that may happen to a locomotive equipped with the Walschaert motion; and this Division is representative of the whole book; the matter is so plainly written, and complete, that this last Division of the work will enable any engine man who has a common school education to pass any examination on valve motion, or the Walschaert Gear.

Send for a special circular of this book as well as Our Other Railroad Books.

Copies of this book sent prepaid on receipt of price. Write for our special terms. You can make equal to a month's pay selling our books on the side.

THE NORRMAN W. HENLEY PUBLISHING CO.  
132 Nassau St., New York, U. S. A.

kinetic friction due to change of speed is modified by the length of time the shoe and wheel are in contact. This modification is due to the heating, wearing away, and polishing of the surfaces in contact, and the lubricating effect of molten particles and the roller-like action of the larger particles torn off. Thus the smoothing and polishing of the surfaces all tend to keep the coefficient down below what it would change to if this action were not present. Numerous experiments show that the increase in the coefficient of brake shoe friction, and consequent increase of retarding force which takes place as speed decreases, is practically neutralized by the conditions introduced by the "time element," and under such conditions the coefficient is about the same at the end as at the beginning of the stop. This is, however, modified by the degree of hardness of the brake shoe.

An ordinary train of five cars, moving at the rate of 65 miles per hour, contains about 150,000,000 foot-pounds of energy. If it was run against a solid wall, the result would be the same as if

and rails; this is usually called adhesion, and the adhesion depends upon the weight on the drivers and the static coefficient of friction between drivers and rails, just as in the case of the car wheel to which brakes were applied. When a stop is made, each wheel may be retarded up to the limit of frictional resistance between that particular wheel and the rail. Assuming the static coefficient of friction to be the same for all wheels in the train, the retarding power may be proportional to the weight of the entire train, while the accelerating power depends upon the weight resting on the drivers alone. This fact explains the advantages of the multiple unit system of electric train operation, such as a train made up all of motor cars, as compared with a locomotive. The locomotive, in starting a train, is a single accelerating unit, while in stopping, the locomotive and train become a multiple retarding unit system, which is, in the aggregate, the more powerful of the two.

The Chicago Pneumatic Tool Company have issued a booklet which



STEEL GIRDER AND BRICK ARCH RAILWAY BRIDGES

it fell to the earth from a height of 150 ft. Suppose this train to be stopped in 1,400 ft. All this energy has to be harmlessly dissipated, and almost without the notice of those in the cars. In stopping such a train in this distance, more power is used than the heaviest locomotive ever built is capable of exerting. The truth of this statement at once appears when it is remembered that a distance of from 5 to 6 miles is required, even under favorable circumstances, for a locomotive to bring this weight of train up to a speed of 65 miles per hour. Stopping this train in 1,400 ft. means the expenditure of this enormous amount of energy in about one-nineteenth of the space required to develop it.

This is as we would expect it, for in starting the train the locomotive alone was concerned, while in the stop the locomotive and every car takes part. To start a train, the total force exerted by the engine cannot exceed the frictional force between driving wheels

shows some of the users of their Franklin Air Compressors throughout the world. It is arranged geographically by countries, states, towns, users, etc., alphabetically. They have shown following the names of those using two or more the exact number installed at each point, for the convenience of those desiring to investigate these installations. It is a handy reference book for those who desire to examine a Franklin compressor at work in their section of country or their part of the world. The business arising from the sale of these compressors has grown beyond the capacity of the present plant, and the company are now adding another 150 ft. to their machine shop, which will increase the output capacity from 55 to 70 compressors per month.

### Pennsylvania System Increases Pay.

The first of this month saw a very satisfactory increase of pay for the employees of the Pennsylvania. Last month the directors ordered a ten per

cent. increase in the pay of all employ-ees who get less than \$200 a month, and that means the bulk of the men on the road. The order applies to the en-tire system both east and west of Pittsburgh. There were two facts taken into consideration by the board in thus dealing generously with the great majority of workers on the many lines comprehended under the name of the Pennsylvania. One of these was the present great prosperity of the country, and the other was the increased cost of living.

On the lines east and west of Pitts-burgh there are 192,458 men. On the lines east alone there will be 125,440 men who will be benefitted by this or-der and the increased outlay will be over eight millions a year.

Last October the Pennsylvania rail-road readjusted the salaries of general superintendents, principal assistant en-gineers, and superintendents of motive power, by which all received an in-crease aggregating \$4,925 a month. As-sistant engineers, supervisors, signal supervisors and assistants were in-creased by a total of \$5,817 per month.

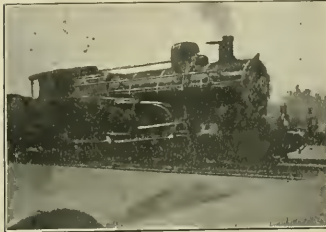

ONE ON THE CONTINENT OF EUROPE

Train masters and assistants, master mechanics and assistants, division op-erators, master carpenters, road foremen of engines, chief clerks and members of the general manager's staff came in for an increase aggregating \$11,634 a month. The relief department was in-creased by \$1,871 a month and the tele-graph operators had \$6,486 added to their pay roll.

In September, 1902, the men who now get the 10 per cent. increase re-ceived a 10 per cent. increase, so that up to date they have received what is equivalent to a 20 per cent. increase of pay. There are on lines east of Pitts-burgh only about 5,000 employees left out and these are mostly not on the permanent force.

The Pennsylvania lines west of Pitts-burgh will in increasing something over 60,000 employees 10 per cent. be called upon to pay out between \$3,500,000 and \$4,000,000 per annum; so that the total yearly extra disbursement of the whole Pennsylvania system east and west of Pittsburgh due to the 10 per cent. in-crease will amount to about \$12,000,000.

**Steam Traps.**

The Joseph Dixon Crucible Co., Jer-sey City, N. J., publish a very interest-ing pamphlet on the subject of steam traps. It is an illustrated description of the several varieties, with valuable suggestions, by Mr. W. H. Wakeman, who is an expert steam engineer and au-thor of well-known books on steam en-gineering. Many people think a steam trap is only a luxury to be enjoyed by those who have expensive plants in operation, but a good trap is valuable according as it prevents waste of steam and so saves coal which must be burned to make the steam. This pamphlet is well worth careful reading, for it is in-structive as well as interesting.

**Six Days Shalt Thou Labor.**

Laws restricting people from engag-ing in business pursuits on Sunday originate mostly from clerical zeal, which is a form of trade unionism in-tended to drive people to attend churches. On the continent of Europe a sort of Sunday observance sentiment is manifesting itself, promoted mostly by the labor elements for the purpose of ensuring one day of rest in seven for every person who needs to work for his daily bread.

In Paris this rule applies to hotels and restaurants, and the keepers of such places are howling mad. Owners of automobiles in France will be re-quired to guarantee their chauffeurs one day of rest in seven.

Under the provisions of a new Bel-gium law, Sunday labor in that coun-try will hereafter be forbidden in all commercial and industrial enterprises except sea, canal and river transport, fishing and hawking and peddling. Only members of an employer's family living with him, or his domestics, may work more than six days per week, and the weekly day of rest is to be Sunday.

"The Mechanical World" Pocket Di-ary for 1907 has already reached us containing a collection of useful engi-neering notes, rules, tables and other data, much of which is particularly in-teresting to railway men. This little book is very popular among British en-gineers and it is pleasing to observe that the work has been thoroughly re-vised and a number of new features added. The section on Gas engines has been entirely re-written by an expert, and is in itself a concise epitome of the design, construction and working of internal combustion engines. Additions have been made in various other sec-tions and many new illustrations have been added. The work is published by Emmott & Company, 65 King street, Manchester, England, and may be had for sixpence and postage by applying direct.

**International  
Correspondence Schools**



**Are You  
In the Line or  
In the Lead?**

Are you in the dinner-pail line or in the chair of the leader?

The whole world is looking for men who have been trained to lead by doing things with their heads as well as their hands. But where do the leaders come from? From the line of course! Ninety men out of every hundred in good positions began in the line just where you are today. But if you want to get out of the line, *you can*. It's up to you. The INTERNATIONAL CORRESPONDENCE SCHOOLS will show you the way and help you to get there. There is no theory about this. It's a truth backed up by thousands of men who are leaders today because they had a desire to do better and asked the I. C. S. how. Let us show YOU how.

For the mere marking and mailing of the coupon below the I. C. S. will take up your individual case, and explain how it can train you to be a leader in your spare time, in your own home, and on terms to suit your present income. It puts you under no obligation to do this; it is simply investigating the best way in the world to advance yourself. Send in the coupon NOW.

**INTERNATIONAL CORRESPONDENCE SCHOOLS  
Box 805, Scranton, Pa.**

- Please send me, free, your booklet, "1000 Stories of Suc-cess," and explain, without further obligation on my part, how I can qualify for a larger salary in the position before which I have marked X

General Foreman	R. R. Con. Engineer
R. R. Shop Foreman	Civil Engineer
R. R. Trav. Engineer	Bridge Engineer
R. R. Trav. Fireman	Chemist
Locomotive Engineer	Mining Engineer
Air-Brake Inspector	Architect
Air-Brake Repairman	Bookkeeper
Mechanical Engineer	Stenographer
Mechanical Drafts.	Ad Writer
Machine Designer	French } With
Electrical Engineer	German } Edison
	Spanish } Phonograph

Name \_\_\_\_\_  
 Employed by \_\_\_\_\_ R. R.  
 St. and No. \_\_\_\_\_  
 City \_\_\_\_\_ State \_\_\_\_\_

**Scranton, Pa.**

# Tate Flexible Staybolt

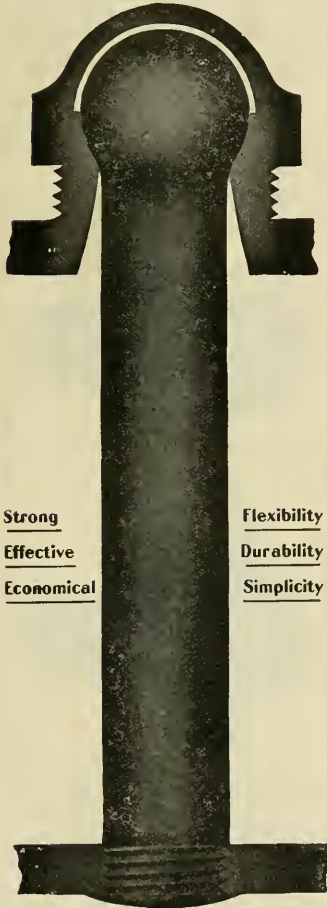

Strong  
Effective  
Economical

Flexibility  
Durability  
Simplicity

Holds firebox sheets securely together, and accommodates itself to the unequal expansion of the plates.

## FLANNERY BOLT COMPANY

PITTSBURG, PA., U. S. A.

Suite 308, Frick Bldg.

B. E. D. STAFFORD, - - General Manager  
Write us for Reference Book

### Hard Service and Good Results.

The King-Lawson Car Company, of New York have recently supplied the Standard Steel Company, at Burnham, Pa., with some of the air-operated side-dump cars, one of which we show in our illustration. The car is, as the steel company have arranged it, with additional side boards over the doors, to enable the car to carry a larger quantity of light material such as ashes or refuse, which accumulates about an establishment such as a steel works.

The way the cars came to be ordered forms an interesting incident in the experience of the King-Lawson Car Company. It seems that after negotiations for cars had been on for a time, the car company supplied one side dump car for a ten days' experiment at the steel works. The car was put into service and it was subjected to harder treatment than the builders at first anticipated, for it

have been doing work, rough and smooth, hot and cold, with entire satisfaction for the past five or six months. This looks as if the King-Lawson car could take care of hot ashes, if such a load was dumped into it direct from the ashpans of locomotives. If such cars were arranged for this service and a suitable pit constructed at a locomotive station, there is every reason to suppose that the shoveling of ashes into cars after ashpans had been cleaned, could be done away with. The act of dumping ashpans would then load the cars.

A pamphlet just published by the American Locomotive Company illustrates and describes Consolidation or 2-8-0 locomotives, weighing more than 175,000 lbs. It is a sequel to the pamphlet which we mentioned in our November issue, page 533, which dealt

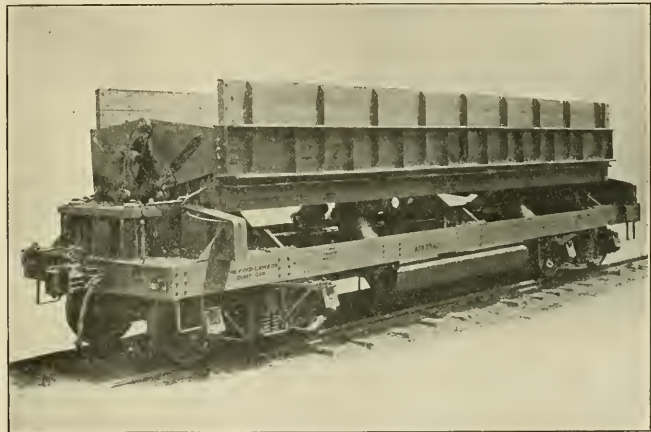

KING-LAWSON AIR OPERATED DUMP CAR

was loaded up with the rejected parts of steel forgings. These odds and ends are what remains after the part used to make the rolled steel wheels has been taken from the flat cakes of steel and they weigh from three to eight hundred pounds each, and when they were loaded into the King-Lawson car they were red hot.

On the occasion when the president of the car company witnessed this heroic treatment, the red hot load was put aboard, the car moved to the steel company's dumping ground and the load discharged, and the car came back for more hot stuff in 20 minutes. This was the first time in the history of the works that a car carrying such a load had gone and come back in the same day, so that anybody who wishes to roughly calculate the percentage in time saving here effected has sufficient data before him.

The cars supplied to the steel works

with those weighing less than this figure. In the pamphlet before us, 28 Consolidation locomotives, built for various railroads, and ranging in weight from 175,000 to 250,000 lbs., are illustrated and the principal dimensions of each design is given. This is the fourth of the series of pamphlets which is being issued by the American Locomotive Company, which will include all the standard types of locomotives. The series so far covers the Atlantic, Pacific and Consolidation types and copies of these pamphlets may be had upon request direct to the company at 111 Broadway, New York.

### A Latin Proverb.

*Ex nihilo nihil fit*—in other words, out of nothing nothing comes—is a fundamental truth old as the hills yet ever new. In the case of railway men it is particularly true that the information

regarding the mechanical appliances used on railways must first be impressed upon the minds of young men before they can be expected to master the details of their work. The older and experienced railway men have enough to do at their work and have little time to instruct others. Many of them resemble the man who made a fortune by minding his own business. Hence the young railway man has many obstacles to overcome.

RAILWAY AND LOCOMOTIVE ENGINEERING lightens his burdens and clears the mysteries for him. We have books also that thousands of railroad men have been reading and gathering knowledge from. A few of our books are as follows:

"Machine Shop Arithmetic." Colvin and Cheney. This is a book that no person engaged in mechanical occupations can afford to do without. Enables any workman to figure out all the shop and machine problems which are so puzzling for want of a little knowledge. We sell it for 50 cents.

"Firing Locomotives." Sinclair. Treats in an easy way the principles of combustion. While treating on the chemistry of heat and combustion, it is easily understood by every intelligent fireman. The price is 50 cents.

"Skeevers' Object Lessons." Hill. A collection of the famous object lesson stories which appeared in this paper several years ago. They are interesting, laughable, and, best of all, they are of practical value to-day. \$1.00.

"Standard Train Rules." This is the code of train rules prepared by the American Railway Association for the operating of all trains on single or double track. Used by nearly all railroads. Study of this book would prevent many collisions. Price, 50 cents.

"Mechanical Engineers' Pocketbook." Kent. This book contains 1,100 pages, 6x3¼ ins., of closely printed minion type, containing mechanical engineering matter. It ought to be in the bookcase of every engineer who takes an interest in engineering questions. We use it constantly as a reference for questions sent to us to be answered. Full of tables and illustrations. Morocco leather, \$5.00.

"Locomotive, Simple, Compound and Electric." Reagan. An excellent book for people interested in any kind of locomotive. It will be found particularly useful to men handling or repairing compound locomotives. It is the real locomotive up to date. \$2.50.

"Simple Lessons in Drawing for the Shop." By O. H. Reynolds. This book was prepared for people trying to acquire the art of mechanical drawing without a teacher. The book takes the place of a teacher, and has helped many

young men to move from the shop to the drawing office. 50 cents.

"Locomotive Running Repairs." By L. C. Hitchcock. This book contains directions given to machinists by the foreman of a railroad repair shop. It tells how to set valves, set up shoes and wedges, fit guides, care for piston packing, and, in fact, perform all kinds of work that need a thoughtful head and skillful hands. 50 cents.

"Care and Management of Locomotive Boilers." Raps. This is a book that ought to be in the hands of every person who is in any way interested in keeping boilers in safe working order. Written by a foreman boilermaker. Also contains several chapters on oil burning locomotives. Price, 50 cents.

"Locomotive Link Motion." Halsey. Any person who gives a little study to this book ceases to find link motion a puzzle. Explains about valves and valve motion in plain language. Price, \$1.00.

RAILWAY AND LOCOMOTIVE ENGINEERING is a practical journal of railway motive power and rolling stock, and it is so not only in name but in reality. By reading it you get a knowledge of what others think and do. \$2.00 per year; bound volumes, \$3.00.

#### Not Very Far Off.

The entire capital in the richest nation or state, consisting of railways, mills, factories, workshops, and dwellings, together with all the goods and wares of every kind—comprising all that has been saved in a useful form, aside from opening of the ways, the clearing of the land and bringing it into productive condition—will not exceed three or possibly four years' production; in most states it is less. If all could be reconverted into food, fuel and clothing, and the world should rest wholly from work, all would be consumed in two or three years. In respect to food, the world is always within a year of starvation, yet there is always enough somewhere.—Popular Science Monthly.

"Graphite as a Lubricant" is out in the form of an elegant pamphlet of nearly 100 pages, profusely and beautifully illustrated. This is the tenth edition of this work, concerning one of the products of the Joseph Dixon Crucible Co., of Jersey City, N. J. It need hardly be stated that the pamphlet excels its predecessors in describing the subject of lubrication generally, and graphite lubrication particularly. The good features of the previous editions are retained, to which is superadded the very latest information, both scientific and practical, on the subject of lubrication. All interested in the subject should secure a copy, which they can do by applying direct to the Joseph Dixon Company.

## Homestead Valves

Straightway, Three-way and Four-way, and

## Homestead Locking Cocks

Are Famous the World Over

They cost more, but are worth very much more than other makes. You try them and see.



Brass, 1¼ in., \$8.00 net

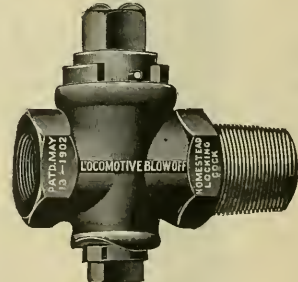

Iron Body, Brass Plug, 1¼ in., \$4.00 net

Homestead Valve Mfg. Co.

WORKS. HOMESTEAD, PA. PITTSBURG, PA.

## American Locomotive Sander Company

13th & Willow Sts., Philadelphia, Pa.

Proprietors and Manufacturers

LEACH, SHEEBURNE, DEAN, SANDERS  
HOUSTON, "SEE" and CURTIS

THE ROBERT W. HUNT & CO.

Bureau of Inspection, Tests and Consultation,  
1137 THE ROOKERY, CHICAGO.

66 Broadway, New York. Park Building, Pittsburgh.

31 Norfolk House, London, Eng.

Inspection of Steel Rail, Splice Bars, Railroad Cars, Wheels, Axles, etc. CHEMICAL LABORATORY—Analysis of Ores, Iron, Steel, Oils, Water, etc. PHYSICAL LABORATORY—Test of Metals, Drop and Pulling Test of Couplers, Draw Bars, etc.

Efficiency Tests of Boilers, Engines and Locomotives.

# XP

## IS THE MARK!

During the Holiday Season we are offering the following books at a reduced price when ordered as one set. The set is designed to be an appropriate and useful

### XMAS PRESENT.

Give it to a friend or secure one for yourself. That is what the initials mean. Write for the **XP** set.

## Locomotive Engine Running and Management

—Sinclair

A book that has probably helped more engineers than any other. Practical, reliable and brought up-to-date. Twenty-first edition ready. **Price, \$2.00**

## Locomotive Link Motion

—Halsey

Treats link motion in a plain, practical way. Shows how it acts and tells why. Explains how valve motion is made and adjusted.

**Price, \$1.00**

## Firing Locomotives

—Sinclair

A readable elementary treatise on combustion, pocket size. Contains much ready and practical information. **Price, 50cts.**

## Air Brake Catechism

—Conger

Convenient size, illustrated, 202 pages. Information concerning the air brake, question and answer form.

**Price, \$1.00**

These four books, price \$4.50, sold for **\$3.50** if ordered as the **XP** set this month.

## Railway and Locomotive Engineering

136 Liberty St New York City

XP-\$3.50 XP-\$3.50 XP-\$3.50 XP-\$3.50

### Marking Track Defects.

Successful use is said to have been made of an automatic device on some of the German railways for ascertaining and definitely indicating defects existing in the track. The principle of the apparatus is based on the fact that every low joint on the track causes a shock of greater or less intensity to a car passing over it. The apparatus is carried in an inspection car, and is so arranged that if the shock exceeds a certain degree of intensity, a squirting device operates, and from it a colored liquid is sprayed over the roadbed at that point, the portion of the track requiring any attention being thus very plainly marked. Such an apparatus, it is said, indicates defects not usually found by a track walker, and it affords evidence of imperfections in the roadbed.

Case-hardening is generally regarded as a cementation process in which carbon is added to the outer shell of metal. Wrought iron contains little or no carbon. Case-hardening adds sufficient carbon to the outer shell to cause it to harden when quenched in cold water. The National Patent Holding Co., Railway Exchange, Chicago, have placed on the market a hardening "compound" which they say increases the point of carbon 18 per cent. above that of bone. Mr. W. White, Vice-President of the company, has published a short treatise explaining the "compound" and its operation.

Prevention is better than cure, especially in case of fire and it is a fact generally acknowledged that if the time spent in summoning the fire department and raising an alarm was spent in extinguishing the fire in its early stages much less loss would be experienced. The H. W. Johns-Manville Co., of New York, claim that the Manville Fire Extinguisher is better than fire insurance. Nearly half a million have been sold. It has a reputation behind it. Write direct to the company for a copy of their illustrated pamphlet.

### Handy Turntable Track Appliance.

There is rather a handy little appliance which can be used on the tracks leading to a turn table, and indeed anywhere in the yard for that matter. The little appliance is called the Hayes pivot derail, and it can be spiked down to a couple of ties close by a rail and the business part of the derail can be turned over on the head of the rail or thrown back out of the way. The business part is hinged to what we may call the seat or base, and that is probably why it is called a pivot derail. The Pivot derail is for hand operation only. It consists of two malleable cast-

ings joined by a  $\frac{7}{8}$  in. cold rolled steel pin. The derail block, which we referred to as the business part, is swung in a vertical semi-circle on to or off of the rail. It is placed between the rails on two ties spaced ten inches apart; it is secured to the ties by four spikes and the flanges on the bottom of the guide box. It is not fastened to the rail. The thrust of a wheel striking the derail block is carried by the seat in the guide box directly to the tie; this seat holds the derail block firmly in place. A lug at the rear of the derail block has a hole for a padlock to secure the derail in the open position; another lug serves for attaching the connecting rod of target stand when that is attached.

When used at or near a turntable it can be turned over on to the rail after an engine has passed into the house and if anything should go wrong or if a leaky throttle should induce an engine to attempt to move out on its own account then the pivot derail would promptly put the offending engine off the track or at least a pair of wheels would go off on the ties, which would be a great deal better than having the



HAYES PIVOT DERAIL

engine fall into the turn-table pit. The pivot rail believes that an ounce of prevention is worth several pounds of cure on a busy railroad.

There is another feature which the modest little derail possesses. It has in itself the essence of the block signal system if used by a man who knows its value. For example, when an engine is ready to come out of the round house the turntable is swung into position and locked, then and not till then the pivot derail may be folded back and a signal to come on the table given. If the man on the engine comes ahead too soon, the derail just puts a wheel on the ties to remind him that he is out of order.

A modification of the pivot variety called the lifting derail can be used on sidings to protect the main line and anywhere where it is desired to secure derail protection. The whole thing can be operated from the main track switch stand by a pipe line connection and when the main track is continuous the pivot derail on the siding, prevents anything drifting out far enough to foul the main line

### Jack Cart.

The heading at the top of this paragraph is not the name of a man or a boy or an apprentice about the shop. The fact is, a correspondent has sent us in a neat little sketch which we reproduce here, of what he calls a jack cart. It is in reality a frame made out of pipe carried on an

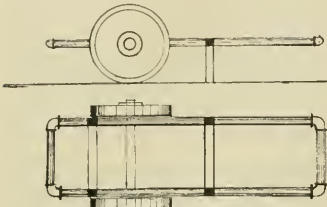

SHOP JACK CART

axle and a pair of wheels with a piece of flat iron bent up under the handles as a pair of legs to keep the whole thing level. Another piece of flat iron with ends bent round the pipe acts as a cross brace. There is or is not a floor to this jack cart, according to the taste and fancy of the builder. The jacks can be laid across the frame and taken easily and quickly anywhere about the shop, and when not in use it can be up-ended in the corner. The cart by itself is light and strong and is a useful shop appliance. This is not a pipe dream, notwithstanding what may be said about the material used in the construction of its frame.

The Pennsylvania have recently paid a sum of money in prizes to the men in charge of their tracks between New York and Pittsburgh, and between Philadelphia and Washington. The object of giving the prizes is to excite legitimate rivalry among supervisors and assistant supervisors in the work keeping the tracks of their respective divisions in the safest and best condition.

There is one known as the "Klondyke prize," which is awarded for the best line and surface maintained for the whole year. A prize of \$1,000 is awarded for the greatest improvement in line and surface in the year.

The Catalogue of the Ekert Elastic Steam Packing sets forth in brief form the qualities of this form of packing which is said to combine the greatest possible resisting qualities of metal with the elasticity of rubber. A series of experiments the results of which are given in the catalogue make it appear that the Ekert packing will resist a steam pressure of 1,000 lbs., a mechanical pressure of 20,000 lbs., and a temperature of superheated steam of 900 degrees Fahrenheit. Engineers

and others interested should send for a sample package to the Ekert Co., Dayton, O.

On the Isle of Portland, in the south of England, there are certain quarries of limestone which have been worked for many years, in former times producing building stone. In 1824 an Englishman named Joseph Asplin, of Leeds, patented a process for mixing and burning lime and clay. The product looked so much like the Portland limestone that he called it "Portland cement," from which the commonly known name given to nearly all kinds of hydraulic cement was derived.

The Ingersoll-Sergeant Rock Drills, for tunneling, mining, quarrying and general rock excavating, are minutely explained in the company's new catalogue, No. 45B. The illustrations are in the highest style of the art while the letter press is a fine sample of the best printing. The whole process of rock drilling and cutting is shown like a panorama, and the minutest details of the construction of the machines and the methods of operating are given. Many of the photographic reproductions are exceedingly interesting from the fact that they illustrate actual incidents of operation in mining and excavating work. Copies of the catalogue may be had from the Ingersoll-Rand Company, New York.

### Modest Sand Cart.

A correspondent has sent us in a drawing of a very modest and highly respectable sand cart for use in and about a locomotive shop. This cart is so made that when loaded with sand and tipped forward so as to be wheeled along nearly the whole weight comes on the wheels, and when it is tipped up by the operator (if we may so speak of the sand

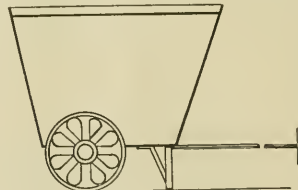

ONLY A MODEST SAND CART

man) the load easily falls out or can be shoveled up or brushed away. The sand cart, however, can be used for a variety of things. As a rubbish receptacle it will take in a whole lot, and it has been known to carry castings and rough freight generally around the shop with the easy grace of a modern steel high side hopper bottom 90 per cent. dump gondola. It is not afraid of hard rough work for it generally has plenty of sand.

### MASTER CAR BUILDER is Open for Engagement

Young, Active, used to Big Propositions; Capable of Installing Piece Work; Steel Car Work Handled; No Afraid of Hard Work.

Further Particulars by Addressing

J. R. P.

Care ANGUS SINCLAIR CO.

136 Liberty Street

New York

## THE UNION SWITCH & SIGNAL CO.

Consulting and Manufacturing  
Signal Engineers

Automatic Block Signals—Electric  
and Electro-Pneumatic

Interlocking—Electric, Electro-Pneumatic  
and Mechanical

Electric Train Staff Apparatus

GENERAL OFFICES AND WORKS AT  
SWISSVALE, PA.

### DISTRICT OFFICES:

New York: 143 Liberty Street

Chicago: Monadnock Block

St. Louis: Frisco Building

## TANITE

THE TANITE CO., of Stroudsburg, Pa., asks for the support of Railroad men, because: The man who uses a TANITE Emery Wheel will find it safe. Because the man who pays for a TANITE Emery Wheel will get the wheel which has the greatest productive capacity. Because its Emery is mined by itself in America, and deserves the support of all mechanics earning wages in America. Because its machines are practical.

The TANITE CO. sells Emery, Solid Emery Wheels, Grinding Machines, Boring Lathes and Polishing Machines, Guide Bar Grinders, Car Brakes & rollers, Surfacing Machines, Open Side Emery Planers, Planer Knife Grinders, Saw Gummers, Bench and Column Grinders, Diamond Tools for Brasses and Steels. The TANITE CO. build special machines for special wants.

—THE—  
**Tanite Co.**  
STROUDSBURG, PA.

## Locomotive Blow-Off Plug Valves

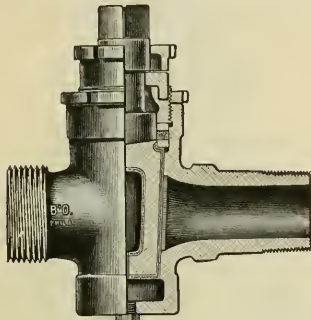

Fig. 9.

All Brass, extra heavy, with Cased Plug. For 250 lbs. pressure. Made with Draining Plug to prevent freezing.

## Locomotive Gauge Cocks

For High Pressure.

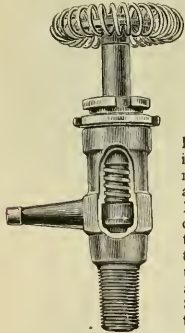

Fig 23, with Wheel.

Bordo Self-Grinding Gauge Cocks, made with renewable Hard Bronze Disc. Opened and closed with a quarter turn. Guaranteed Steam tight under the most exacting conditions. Shanks Threaded to specifications for Locomotives.

## Swing-Joints and Pipe Attachment



Fig. 33.

May be applied between Locomotive and Tender.

These Swing-Joints are suitable for Steam, Gas, Air, Water or Oil.

Complete Booklet on Application

**L. J. BORDO CO.**  
PHILADELPHIA, PA.

## Engine for the Belgian State Railways.

BY E. C. M.

The locomotive which we here illustrate was exhibited at the Liege Exhibition, and is used in express passenger service on the Belgian State Railways. It is of the simple type, with inside cylinders and Stephenson link motion, and is representative of the Belgian standard of four-coupled express locomotives, of which there are 140 in actual service.

The boiler of the locomotive is of the ordinary cylindrical form, with plain brass tubes, copper fire box, double-beat regulator, and Wilson safety valves. The main valves are of the usual D-slide type. The axle boxes are of bronze, lined with white metal, and are provided with cast iron sponge boxes. The springs of the rear driving wheels and those of the bogie are of the laminated type, while those of the main

the lighting throughout the train, the headlight is also electric, and by means of a switch situated in the cab, may be changed from white to red, or vice versa, during shunting operations. A number of small lamps are provided in the cab, which throw light on the gauges, water glass, etc. In proximity to the motion and other moving parts lights are provided, which can be used during inspection. Accumulators are placed under each carriage for reserve lighting, one set of these being also attached to the platform of the locomotive. The capacity of these accumulators is such as to give about three hours' lighting.

The tender frame is constructed of mild steel plates and angles. A well is provided at the bottom of the main tank, between the frames. Steel T's and angles are attached to the inside of the latter, and longitudinal and trans-

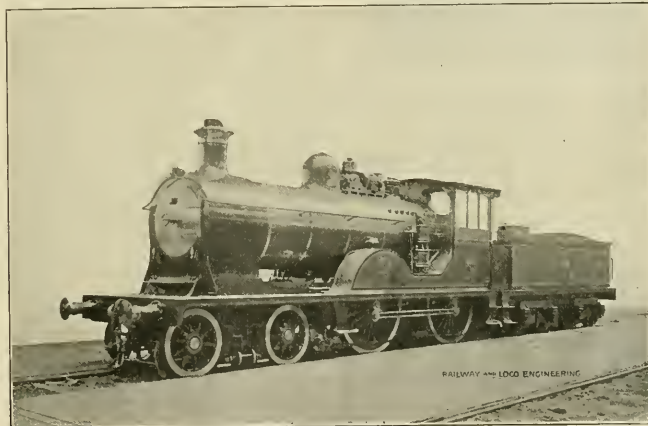

FOUR CYLINDER EXPRESS ENGINE FOR THE BELGIAN STATE RAILWAYS

driving wheels are of the Timmis spiral type.

The bearing upon which the bogie center rests is swung from the truck, and admits of a transverse movement of  $\frac{3}{4}$  in. to each side. Compressed air sanding gear is fitted, air being taken from the chamber of the Westinghouse brake, with which brake this engine is equipped. Brake blocks are applied to all the wheels, those of the bogie included.

The main feature of the engine is that it is fitted with a new type of electric light generating plant. As seen in the illustration, this apparatus is placed on the top of the boiler, and consists of a small dynamo driven by a single acting high speed vertical engine having constant admission. This vertical engine has been very carefully balanced in order to reduce vibration. Its action is automatic, and it requires no attention when once started. In addition to

verse stays are riveted to them for the purpose of increasing the rigidity and strength. A dial and pointer indicate the height of the water. A hand brake, in addition to the fittings of the Westinghouse brake, and the usual equipment of tool boxes, train heating pipes, etc., are provided. The tender is carried on two 4-wheel bogies, and the tank holds 3,960 gallons of water and  $5\frac{1}{2}$  metric tons of coal.

Some of the principal dimensions are as follows:

Cylinders, 19x25.98 ins.; boiler pressure, 191 lbs.; boiler greatest inside diameter, 4 ft. 8  $\frac{3}{16}$  in.; distance between the tube plates, 11 ft. 4  $\frac{1}{2}$  ins.; number of tubes, 265; outside diameter of tubes, 1  $\frac{3}{4}$  ins.; heating surface of fire box, 131 sq. ft.; heating surface of tubes, 1,234 sq. ft.; total heating surface, 1,365 sq. ft.; grate area, 22 sq. ft.; diameter of driving wheels, 6 ft. 6 ins.; total length of wheel base, 23 ft. 6 ins.; fixed wheel base, 9 ft. 6 ins.; bogie wheel base, 6 ft. 6 ins. Distributed load, full working order, 1st bogie axle, 8 tons 10 cwt.; 2d bogie axle, 8 tons 8 cwt.; leading axle, 18 tons; trailing axle,

**STANDARD MECHANICAL BOOKS  
FOR ROAD AND SHOP MEN  
BY CHAS. McSHANE**

**The  
Locomotive Up to Date**

Price, \$2.50

**New York and  
Westinghouse Air Brakes**

Price, \$1.50

**One Thousand Pointers for  
Machinists and Engineers**

Price, \$1.50

All books bound in fine cloth

AGENTS WANTED everywhere; write for terms and descriptive circulars. Will be sent prepaid to any address upon receipt of price.

**GRIFFIN & WINTERS**  
171 La Salle Street, CHICAGO

# TOOL STEEL

## Die Blocks Steel Forgings

First Prize awarded at the Louisiana Purchase Exposition, at St. Louis, for our **TOOL STEEL** when placed in competition with the best makes in England and Germany.

Write for information and Prices.  
Specify McInnes Tool Steel when ordering.

# McINNES STEEL CO.

CORRY, PA.

17 tons 12 cwt.; total weight of engine in full working order, 52 tons 10 cwt.; total weight of engine, empty, 48 tons.

The car foreman and also the inspector and the car repairer need not be in doubt as to the meaning of the M. C. B. rules of interchange if they get hold of the handy little Catechism of the M. C. B. rules for 1906, issued by the McConway & Torley Company, of Pittsburgh, Pa. The pamphlet fits the pocket, it has 117 questions and answers on the rules and it has illustrations of various things, among them being the method of splicing wood or steel car sills. You can have the booklet if you send in a request to the makers of the Janney, Kelso and Pitt couplers. The same company have also issued a pamphlet called Ready Reference Tables and price list. It is designed for those handling M. C. B. coupler accounts and orders and, indeed, any car department employee can have one by writing to the McConway and Torley Co. The names of the couplers in general use are given with new and second hand prices and also prices of wheels and axles. What constitutes unfair usage; cost of cast iron per pound, all figured out at 1 1/4 cents per lb. and also the value of cast iron scrap at 1/2 cents per lb. and cost of lumber at 3 1/4 cents per ft. All this useful information and saves a world of arithmetical work. Metal brake beams and parts with prices new and scrap are given and the value of new car bodies and trucks and a table of yearly and monthly depreciation value of one dollar at five per cent. Send for the reference table if you are interested, it can be had for the asking.

The badge used by the North Staffordshire Railway, of England, is one of the quaintest signs to be seen anywhere. It is in the form of a knot, and is painted in gold on the sides of the engine tenders. The sign is known as the "Stafford Knot," and was borne years ago by the Barons Stafford. It is now adopted by the Dukes of Sutherland, whose eldest sons bear the title of Marquess of Stafford. Various American railroad companies have attempted to popularize badges for locomotives and cars, but the levity of American trainmen turned the sign into ridicule. One railroad company uses a badge which trainmen call the "liver pad."

Some time ago the Gold Car Heating and Lighting Company, of New York, issued a large catalogue covering all their products. They have now reprinted the portion which deals with railway car heating, which shows the application of the Gold Improved Temperature Regulator, and explains its working. This pamphlet, or indeed the full catalogue

This illustration shows the form of construction of the

## Dart Patent Union

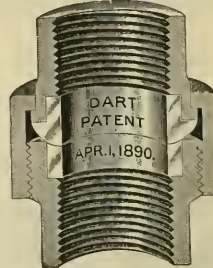

Every feature of construction represents the best points to insure stability and durability. The malleable iron pipe ends and nuts, in combination with bronze metal seats, are as near perfection as is possible to approach, and the sales to date indicate the public approval. There are none so good. For sale by all the principal jobbers in United States, Canada and Europe.

**E. M. Dart Mfg. Co., Providence, R. I.**  
FAIRBANKS CO., SALES AGENTS.



## The Twentieth Century Master Mechanic

Won't use Solid Mandrels.  
Cost too much, take up too  
much room and don't give  
satisfaction.

### Nicholson Expanding Mandrels

Take everything from 1 to 7  
inch holes. Take up little  
room — always ready and  
you can buy four sets for  
the cost of one of the solid  
kind

### Are You Using Them?

Catalogue tells you  
more about them.

**W. H. Nicholson & Co.**  
Wilkesbarre, Pa.



# One Year and Eleven Months'

## SERVICE

WITHOUT REPACKING, ON

### HIGH-PRESSURE LOCOMOTIVES

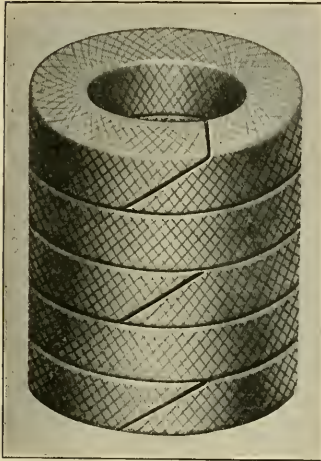

Style 300 TV.

A throttle failure is an absolute impossibility where Crandall's Throttle Valve packing is used.

IT WILL NOT BLOW OUT

## Crandall Packing Co.

FACTORY AND GENERAL OFFICE

PALMYRA, - NEW YORK

BRANCHES

New York 136 Liberty St. Cleveland 9 So. Water St.  
Chicago 52 West Washington St.

# Patents.

GEO. P. WHITTLESEY

McGILL BUILDING WASHINGTON, D. C.

Terms Reasonable. Pamphlet Sent

## Molding Machines

Vertical Vibration. Power Drive

ALL KINDS OF MACHINES

THE E. H. MUMFORD CO.

17th & Callowhill Streets, PHILADELPHIA, PA.  
J. W. JACKMAN & CO., Ltd., 39 Victoria St. London, S. W.

itself, can be obtained by writing to the company, Whitehall building, New York. The reprint in pamphlet form is spoken of as something new and interesting on the subject of railway car heating.

The Latin motto, "ex inutili utilitas," is used on the trademark of the Tanite Company, of Stroudsburg, Pa., and it tells the principal fact about the interesting substance they deal with, in perhaps the fewest words possible. Tanite is made by a process known only to the manufacturers, from waste leather, etc., and when used, as it is, with emery in the Tanite emery wheels, forms an abrasive of high quality. The Tanite Company in thus using what would otherwise go to waste make good the claim contained in the motto on their trade mark and which may be freely translated, "From what is worthless comes that which is of use." Tanite and emery can be moulded under heat and pressure and thus abrasive wheels of all sizes and shapes can be made. The Tanite Company sells emery, also solid emery wheels, buffing lathes and polishing machines, guide bar grinders, car brass grinders, surfacing machines, open side emery planers, planer knife grinders, saw gummers, bench and column grinders, diamond tools, speed indicators, emery wheel dressers, polishing paste for brass and nickel. The Tanite Company also build special machines for special wants. Write direct to the company at Stroudsburg for particulars of any of these useful machines.

One of the finest catalogues of the season has just been issued by the Chicago Pneumatic Tool Company. This company has kept its place in the front rank in the development of pneumatic tools. In the construction of machinery necessary for the production of compressed air they have attained a high degree of perfection. A perusal of the superbly illustrated catalogue will show that the company is enabled to furnish pneumatic equipment embracing every feature of the installation.

The Monon is rapidly building its new line from Linton, and expects to have the road in operation by February 1 as far as Quincy. It is the intention to build on to Indianapolis via Mooresville. From Quincy to Indianapolis is just 40 miles, and from Quincy to Mooresville is 24 miles. Most of the mileage is through a level country, and the company has received much encouragement in building.—N. Y. Commercial.

"What funny little noises your baby makes with his mouth, doesn't it?" "Yes. I think it wants to learn to become a railway brakeman."—Milwaukee Sentinel.

## METAL PRESERVATIVE PAINTS AND PRIMER

for locomotives, boilers, stacks, front-ends, gearing, framework, metal roofs, etc.

Tell us your needs.

Metal preservative paints have been our speciality for 23 years.

Paints for all conditions.

THE STANDARD PAINT CO.

Sole Manufacturers

100 William St., New York  
CHICAGO ST. LOUIS

## CYLINDER BORING BARS

### VALVE SEAT ROTARY PLANING MACHINES

### CRANK PIN TURNING MACHINES

*Write for Catalog*

## QUINCY, MANCHESTER, SARGENT CO.

OLD COLONY BLDG. 114 LIBERTY ST.  
CHICAGO NEW YORK

MACHINERY SALES DEPT.  
PLAINFIELD, N. J.

## SKAT! Off Comes the Dirt.

When the hands are smeared and stained with a greasy grimy coat of oil, soot, dust and dirt, rub on a little

# SKAT

TRADE MARK

**The Best Hand Soap Known**

and see how quickly they're clean and soft again. SKAT is made to do what ordinary hard soaps can't do. Gets into the pores and loosens all the dirt so it simply rubs off. Pure, effectual and beneficial to the skin. 10 cents a can.

Write postal for free sample and we will tell you where to buy SKAT, or if not sold in your locality, will tell you how you can become our exclusive agent and make money selling it. Write to-day.

THE SKAT MANUFACTURING CO.,  
807 Park Street, Hartford, Conn.

TRADE MARK  
*The Sargent Glove*  
MARK



**SAVE DOLLARS**

**By wearing "Sargent Gloves"**

you will save money because you buy fewer gloves during the year. Write for our illustrated booklet and "Sargent" leather match safe made from the same leather as the gloves.

If your dealer does not carry "Sargents" we will sell you direct on receipt of your size and \$1.00.

Manufactured Exclusively by  
**DETROIT LEATHER SPECIALTY CO.**  
DETROIT, MICH.

The Swift Paint Company have a liberal proposition to offer **paint and varnish salesmen with established railroad trade**, who are in position to sell **Black Giant Front End Enamel** on the side. **Black Giant Front End Enamel** is a thin, glossy, black paint, easily applied. A small quantity covers a large surface. It does not scale or crack, but eventually burns to a powder which can be brushed off down to the bare iron with a wire brush. Guaranteed to last in good shape for ten days to two weeks. Not expensive. Samples on application.  
The Swift Paint Co., Cleveland, O.

**INDEX TO ADVERTISEMENTS.**

Acme Machinery Co. .... Front Cover	582	Niles Cement-Fond Co. .... 14
Air Brake Chart. .... 11	3	Norton Grinding Co. .... 5
Ajax Metal Co. .... 4th Cover	13	Norwalk Iron Works. .... 20
Aldon Co. .... 11	571	Pacific Trading Co. .... 2
American Balance Valve Co. .... 4th Cover	—	Pennsylvania R. R. .... 19
American Brake Shoe Co. .... 9	—	Pittsburgh Spring & Steel Co. .... 2
American Loco Sander Co. .... 9	5	Porter, H. K., & Co. .... 5
American Locomotive Co. .... 9	13	Praitt & Whitney. .... 12
American Locomotive Equipment Co. .... 4th Cover	—	Pressed Steel Car Co. .... 15
American Valve and Meter Co. .... 2d Cover	15	Prosser, Thos., & Son. .... 581
Armstrong Bros. Tool Co. .... 9	2d Cover	Quincy, Manchester Sargent Co. .... 2d Cover
Armstrong Mfg. Co. .... 9	2	Railway Materials Co. .... 12
Audel, Theo. Co. .... 14	20	Railway Steel Spring Co. .... 4
Baker, Wm. C., Heating and Supply Co. .... 3	20	Ralston Car Co. .... 3d Cover
Baldwin Locomotive Works. .... 3	8	Revere Rubber Co. .... 2
Ball Webb, C. Co. .... 12	572	Rogers, H. A., Co. .... 19
Barnett, G. & H., Co. .... 2d Cover	23	Rock Island Frisco Lines. .... 20
Barnett Machine Tool Co. .... 24	23	Rogers Locomotive Works. .... 13
Bettendorf Axle Co. .... 24	2d Cover	Rue Mfg. Co. .... 5
BOOKS.—	580	Safety Car Heating & Lighting Co. .... 2
Air Brake Chart. .... 11	4th Cover	Saunders, D., Sons. .... 5
Compound Locomotives. .... 16	20	Scandinavia Belting. .... 2
Computers. .... 25	573	Sellers, Wm., & Co., Inc. .... 581
Conger's Air Brake Catechism. .... 8	20	Sight Feed Oil Pump Co. .... 16
Firing Locomotives. .... 8	576	Stat Mfg. Co. .... 15
Locomotives Running and Management. .... 21	576	Slocumb, F. F., & Co. .... 14
Machine Shop Arithmetic. .... 21	574	Smooth-On Mfg. Co. .... 15
Miscellaneous. .... 18	4th Cover	Southern Pacific R. R. .... 2d Cover
Oil Burning in Locomotives. .... 18	574	Standard Car Truck Co. .... 3
Train Rules and Train Dispatching. .... 18	574	Standard Coupler Co. .... 581
Twentieth Century Locomotives. .... 577	18	Standard Paint Co. .... 12
X. P. set for Christmas. .... 579	26	Standard Steel Works. .... 11
Bordo, L. J., Co. .... 10	15	St. Louis Car Co. .... 10
Boston & Maine R. R. .... 10	2d Cover	Star Brass Mfg. Co. .... 11
Carpenter, The J. M., Tap & Die Co. .... 19	15	Starrett Co., L. S. .... 580
Central R. R. of New Jersey. .... 19	9	Storms Mica Co. .... 7
Chalfonte Hotel. .... 1	7	Syrington, T. H., & Co. .... 582
Chapman Jack Co. .... 7	9	Swift Paint Co. .... 7
Charts.—	1	Tabor Mfg. Co. .... 4
Combination Passenger & Sleeping Car. .... 17	1	Taimare Mfg. Co. .... 578
Locomotive, Atlantic Type. .... 1	15	The Tanite Co. .... 7
Locomotive, American Type. .... 10	4	Underwood, H. B., & Co. .... 15
Chicago Car Heating Co. .... 15	19	Union Pacific R. R. .... 578
Chicago Pneumatic Tool Co. .... 10	22	Universal Switch & Signal Co. .... 23
Chicago & Alton R. R. .... 20	22	United States Metallic Packing Co. .... 12
Cleveland City Forge & Iron Co. .... 4th Cover	2d Cover	Uica Steam Gauge Co. .... 25
Cleveland Twist Drill Co. .... 4th Cover	580	Vacuum Cleaner Co. .... 12
Climax Bearing Co. .... 24	10	Van Duzen Co. .... 25
Commercial Acetylene Co. .... 16	581	Valcan Iron Works. .... 2d Cover
Commonwealth Steel Co. .... 16	10	Walker A. Penton. .... 2d Cover
Consolidated Railway, Electric Lighting & Equipment Co. .... 581	10	Walworth Mfg. Co. .... 4th Cover
Cradall Packing Co. .... 9	5	Washington Co. .... 4th Cover
Damascan Bronze Co. .... 580	14	Watson-Stillman Co. .... 7
Dart, E. M., Mfg. Co. .... 12	581	Westinghouse Air Brake Co. .... 7
Davis John Co. .... 23	15	Westinghouse Electric & Mfg. Co. .... 22
Detrol Leather Specialty Co. .... 582	5	Whiting Foundry Equipment Co. .... 581
Detrol Lubricator Co. .... 13	10	Whittlesey, Geo. P. .... 5
Detrol Seamless Tube Co. .... 571	8	Williams Typewriter Co. .... 7
Dixon, Joseph, Crucible Co. .... —	10	Wood, R. D., & Co. .... 16
Ekerl High Resistance Co. .... —	8	Zephon Chemical Compound Co. .... 16
Expanded Metal Co. .... 5	8	
Falls Hollow Staybolt Co. .... 13	8	
Fay & Egan Co., A. .... —	8	
Fitz Hugh Lather Co. .... 15	8	
Flanders, L. B., Machine Works. .... 575	8	
Flannery Bolt Co. .... 2	8	
Franklin Mfg. Co. .... 2d Cover	8	
Frost Railway Supply Co. .... 2d Cover	8	
Galena Signal Oil Co. .... 20	8	
Garlock Packing Co. .... 8	8	
General Electric Co. .... 572	8	
Gold Car Heating Co. .... 23	8	
Goodrich Rubber Co. .... 23	8	
Gould Coupler Co. .... 2d Cover	8	
Greene, Tweed & Co. .... 2d Cover	8	
Griffin & Winters. .... 4th Cover	8	
Hammett, H. G. .... 20	8	
Hancock Inspirator Co. .... 573	8	
Hendrick Mfg. Co. .... 20	8	
Henley & Co. .... 20	8	
Hicks, F. M., & Co. .... 20	8	
Hoffman, Geo. W. .... 576	8	
Homestead Valve Mfg. Co. .... 576	8	
Hunt, Robert W., & Co. .... 574	8	
Illinois Central R. R. .... 574	8	
International Correspondence Schools. .... 4th Cover	8	
Jenkins Bros. .... 18	8	
Johns-Manville, H. W., Co. .... 26	8	
Kennicott Water Softener Co. .... 26	8	
King-Lawson Car Co. .... 15	8	
Kinear Mfg. Co. .... 15	8	
Lackawanna R. R. .... 9	8	
Lake Shore. .... 9	8	
Latrobe Steel & Coupler Co. .... 7	8	
Lexington Hotel. .... 7	8	
Locomotive Charts.—	1	
Atlantic Type. .... 1	15	
Locomotive Publishing Co., Ltd. .... 4	19	
Long & Allister Co. .... 22	22	
Magnus Metal Co. .... 22	22	
Manning, Maxwell & Moore. .... 2d Cover	2d Cover	
McConway & Torley Co. .... 580	2d Cover	
McCord & Co. .... 10	2d Cover	
Illines Steel Co. .... 581	2d Cover	
More, James Brass and Metal Co. .... 10	2d Cover	
Morse Twist Drill Co. .... 581	2d Cover	
Mumford, The E. H., Co. .... 581	2d Cover	
Nathan Mfg. Co. .... 15	2d Cover	
National Acme Mfg. Co. .... 4th Cover	2d Cover	
National Malleable Castings Co. .... 10	2d Cover	
New Jersey Asbestos Co. .... 8	2d Cover	
New York Central R. R. .... 580	2d Cover	
Nicholson, W. H., & Co. .... 580	2d Cover	









P            Railway and Locomotive  
Tech        Engineering  
R            v.19(1906)

Physical &  
Applied Sci.  
Serials

---

**PLEASE DO NOT REMOVE  
SLIPS FROM THIS POCKET**

---

---

**UNIVERSITY OF TORONTO  
LIBRARY**

