

## Historic, archived document

Do not assume content reflects current scientific knowledge, policies, or practices.

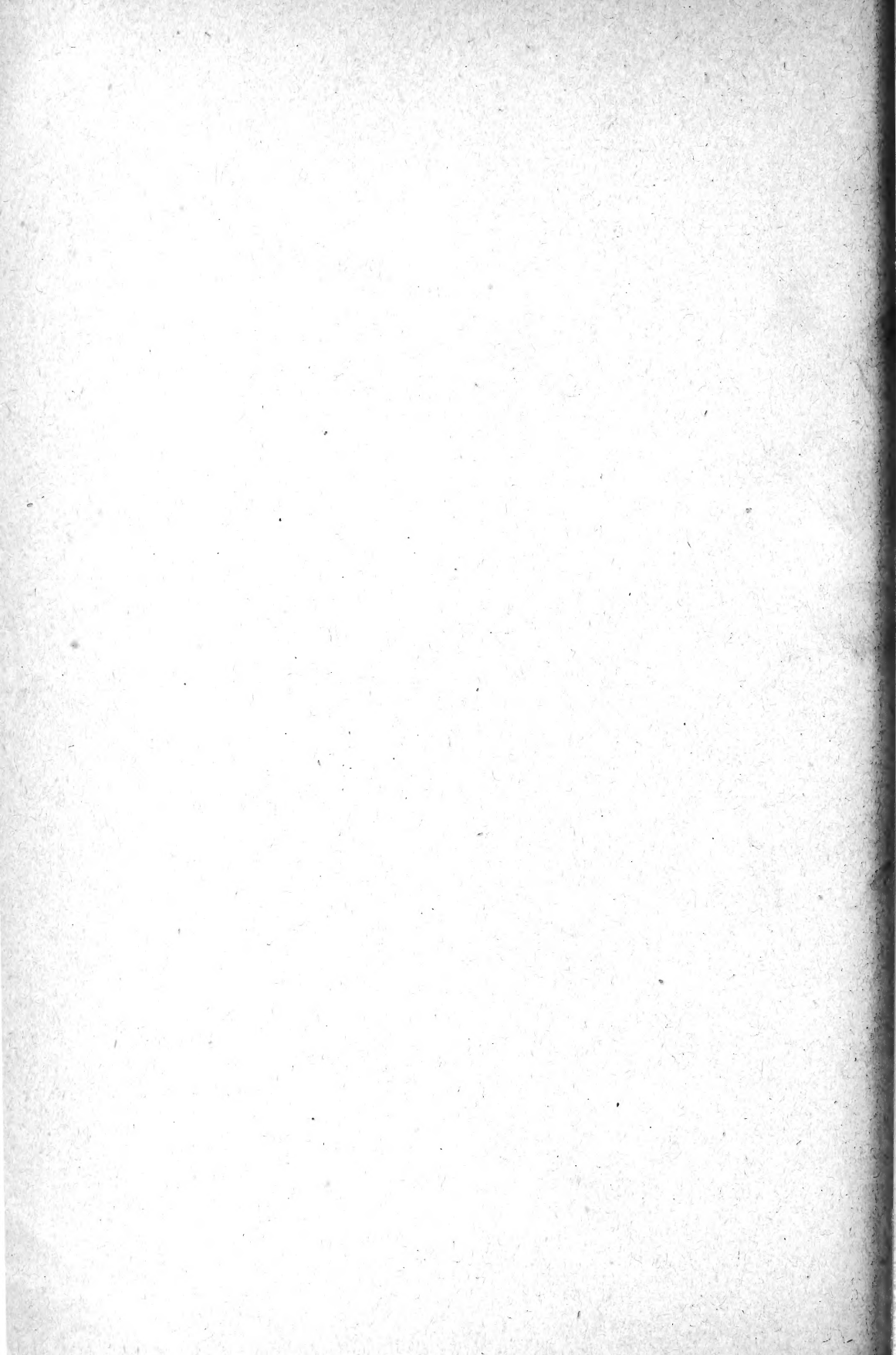

U. S. DEPARTMENT OF AGRICULTURE.

BUREAU OF PLANT INDUSTRY—BULLETIN No. 4.

B. T. GALLOWAY, Chief of Bureau.

---

# RANGE IMPROVEMENT IN ARIZONA.

(COOPERATIVE EXPERIMENTS WITH THE ARIZONA  
EXPERIMENT STATION.)

BY

DAVID GRIFFITHS,

EXPERT, IN CHARGE OF FIELD MANAGEMENT,  
GRASS AND FORAGE PLANT INVESTIGATIONS.



WASHINGTON:  
GOVERNMENT PRINTING OFFICE.  
1901.

**BUREAU OF PLANT INDUSTRY.**

OFFICERS.

BEVERLY T. GALLOWAY, *Chief of Bureau.*

ALBERT F. WOODS, *Pathologist and Physiologist.*

FREDERICK V. COVILLE, *Botanist.*

G. B. BRACKETT, *Pomologist.*

F. LAMSON-SCRIBNER, *Agrostologist.*

**GRASS AND FORAGE PLANT INVESTIGATIONS.**

SCIENTIFIC STAFF.

F. LAMSON-SCRIBNER, *Agrostologist.*

A. S. HITCHCOCK, *Assistant, in Charge of Cooperative Experiments.*

DAVID GRIFFITHS, *Expert, in Charge of Field Management.*

ELMER D. MERRILL, *Assistant Agrostologist, in Charge of Collections.*

C. R. BALL, *Assistant Agrostologist, in Charge of Experiments in the District of Columbia.*

U. S. DEPARTMENT OF AGRICULTURE.

BUREAU OF PLANT INDUSTRY—BULLETIN No. 4.

B. T. GALLOWAY, Chief of Bureau.

---

# RANGE IMPROVEMENT IN ARIZONA.

(COOPERATIVE EXPERIMENTS WITH THE ARIZONA  
EXPERIMENT STATION.)

BY

DAVID GRIFFITHS,

EXPERT, IN CHARGE OF FIELD MANAGEMENT,  
GRASS AND FORAGE PLANT INVESTIGATIONS.



WASHINGTON:  
GOVERNMENT PRINTING OFFICE.  
1901.

Withdrawn  
FEB 7 '40

## LETTER OF TRANSMITTAL

---

U. S. DEPARTMENT OF AGRICULTURE,  
BUREAU OF PLANT INDUSTRY,  
OFFICE OF THE CHIEF,  
*Washington, D. C., September 6, 1901.*

SIR: I have the honor to transmit herewith the manuscript of a paper on "Range Improvement in Arizona," by Dr. David Griffiths, expert in charge of field management in the Office of the Agrostologist, and respectfully recommend its publication as Bulletin No. 4 of this Bureau.

Respectfully,

B. T. GALLOWAY, *Chief.*

Hon. JAMES WILSON,  
*Secretary of Agriculture.*

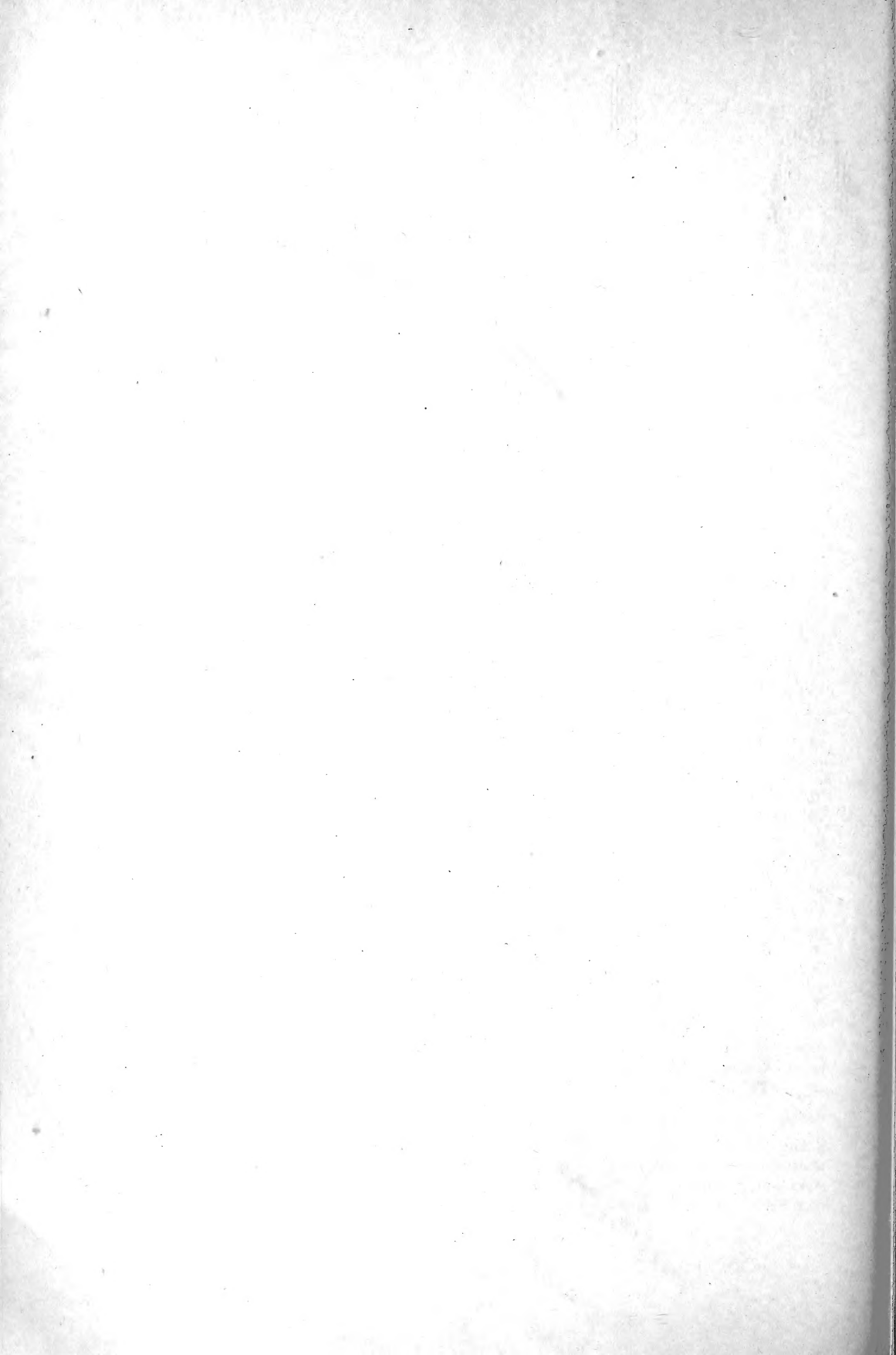



## PREFACE.

---

This paper of Dr. Griffiths is the first report on experiments with grasses and forage plants conducted by the Department of Agriculture through this office in cooperation with the Agricultural Experiment Station of Arizona, located at Tucson. The report contains an outline of the experiments undertaken on the tract of public land set aside by the President of the United States for the use of the Secretary of Agriculture in this work. The existing conditions and the present character of the forage supply on the ranges is fully described. The urgent needs of the stockmen for better range conditions are clearly set forth. The publication of this report now will be most timely, as it brings before the public questions of the greatest importance to one of the largest interests of this country—the raising of live stock. While there are many forage problems of great importance which are now being worked out through this Office, there is none, we believe, of greater importance or more general interest than that of range improvement. The free-range system has led to the ruthless destruction of the native grasses which once covered the magnificent pasture lands of the West, and the time has now come when active measures must be adopted to remedy the evils that have resulted from overstocking and mismanagement. It is evident that laws for the proper control and preservation of the ranges are not only essential to the stock interests, but also to the general welfare of the country. The matter is of as much importance to the irrigation farmer as to the cattle man, for the gulying of river channels during recent years, and the cutting of deep gorges in every slight depression, destroying the tillable lands, are directly traceable to the influence of close grazing.

Prof. R. H. Forbes, director of the Arizona Agricultural Experiment Station, in an exceedingly valuable and interesting paper on the subject of "The open range and the irrigation farmer," read at the meeting of the American Association for the Advancement of Science held in Denver the present season, and which was published in *The Forester*, made the following most suggestive notes in relation to range improvement, which we venture to quote here:

The objects of range study are, in the first place, to demonstrate economic methods for the improvement and reclamation of the great areas of devastated, worn-out grazing lands of the semiarid regions, and, finally, to suggest such administration of the country thus reclaimed, or the yearly decreasing areas of

yet unruined ranges, that the interests of all concerned—the stockman, the irrigation farmer, and the possible investor in the storage propositions of the future—may be brought into harmony with each other as well as be individually bettered.

\* \* \* \* \*

In view of the difficulties and failure which have been encountered in this direction [range improvement] and in view of the successful operations of the forest-reserve system, it seems to me that we can turn with some hope of success to the idea of range reservation in Arizona and New Mexico. The Government is there yet in control of great unbroken tracts of its public lands, and those Territories afford a most favorable opportunity for the institution of the experiment on a large and convincing scale.

\* \* \* \* \*

The carrying out of such a plan by impartial and authoritative means, including provisions for a proper economic and scientific study of the problems involved, ought in time to vastly improve the range for the benefit of the stockman, and also to render the operations of the irrigation farmer and of the storage-reservoir promoter much more certain of returns.

F. LAMSON-SCRIBNER,  
*Agrostologist.*

OFFICE OF THE AGROSTOLOGIST,  
*Washington, D. C., September 6, 1901.*

## CONTENTS.

---

	Page.
Introduction .....	9
Former conditions .....	10
Circular letter and questions .....	10
Answers to questions .....	11
Feed on the range .....	14
The plantains .....	15
Saltbushes and their allies .....	17
Native legumes .....	18
The Cactaceæ .....	19
The grasses .....	20
The range reserve tract .....	23
Area C .....	25
E .....	26
F .....	27
A .....	28
B .....	29
D .....	29
Precipitation records .....	30
Summary and suggestions .....	30

## ILLUSTRATIONS.

### PLATES.

	Page.
PLATE I. Fig. 1. Railroad right of way near Benson, Ariz., showing the condition of the range under protection.....	10
Fig. 2. Wright's Saccaton ( <i>Sporobolus wrightii</i> ) .....	
II. Fig. 1. A cattle range in the Santa Catalina Mountains, April, 1901 .....	12
Fig. 2. A foothill range near Tucson, Ariz., April, 1901 .....	
III. Fig. 1. Tufted plantain ( <i>Plantago fastigiata</i> ) on the left, blue grama ( <i>Bouteloua oligostachya</i> ) on the right.....	14
Fig. 2. Alfilaria ( <i>Erodium cicutarium</i> ) grown on university campus at Tucson, Ariz., April, 1901.....	
IV. Fig. 1. Shad scale ( <i>Atriplex canescens</i> ) in fenced field near Tucson, Ariz. ....	16
Fig. 2. Cattle fed on tufted plantain ( <i>Plantago fastigiata</i> ) and alfilaria ( <i>Erodium cicutarium</i> ) on way to market. May, 1901.	
V. Fig. 1. Operations in range improvement near Tucson, Ariz., January, 1901.....	20
Fig. 2. Range reserve tract near Tucson, Ariz., showing a typical creosote-bush ( <i>Larrea mexicana</i> ) locality.....	
VI. Fig. 1. Cactus ( <i>Opuntia arbuscula</i> ) from range reserve tract near Tucson, Ariz.....	20
Fig. 2. Cactus ( <i>Opuntia fulgida</i> ) .....	

### TEXT FIGURES.

FIG. 1. Diagram of fenced portion of range reserve tract.....	23
2. Diagram of Area C.....	25
3. Diagram of Area E.....	26
4. Diagram of Area F.....	27
5. Diagram of Area A.....	28

## RANGE IMPROVEMENT IN ARIZONA.

By DAVID GRIFFITHS,  
*Expert, in charge of Field Management.*

---

### INTRODUCTION.

On all the Western stock ranges which the writer has visited there have existed many small areas in cultivated fields, unused pastures, fenced railroad rights of way, and similar situations which are in their virgin state or have so far recovered from overstocking as to bear testimony to the original productivity of the soil. Things are far different in large areas of southern Arizona. Here unused pastures are very rare, cultivated fields are fewer in number, and the destruction is so complete that in many localities even the railroad right of way has recovered but little in three or four years' time. On the river bottoms a few indications of luxuriant growths of grass are found, but in nearly every case, even in such favored localities, there is little aside from this evidence, the actual original conditions being very much modified. It would be but fair to state, however, that the season in which the region was first visited was an unfavorable one, being at the close of an exceedingly long dry period, when even evidence of forage was scanty.

Many ranchers, farmers, and prospectors who have lived in the country a long time have given much information relative to former conditions, some certainly reliable and some doubtless extravagant, as is apt to be the case in such matters. From the evidence given by every old settler no conclusion could be reached other than that of misuse of the range country and that the destruction was greater than in the more favored ranges of the Northwest. How the destruction of the range could be so nearly complete is somewhat beyond the conception of those not familiar with the character of the precipitation, configuration of the land, composition of the soils, and the habits of the forage plants of the region. With the exception of the annuals the grasses are nearly all known as "bunch grasses," a designation which indicates that they are not turf formers. Even the blue grama (*Bouteloua oligostachya*), which forms such handsome and persistent sod over vast areas on the ranges of the Northwest, grows here in bunches. This prevailing characteristic, together with the susceptibility of the surface soil to injury by the trampling of cattle, probably accounts in a large measure for the extent of the denudation of the range. During a season of rain the surface of the ground is badly cut by the cattle that tramp over it. After the February rains the

depth of footprints in an average mesa region is one-half an inch to 4 inches, the deeper ones being in the lower moister regions, which are best suited to the growth of vegetation. It will be readily seen that a herd of cattle do immense injury to the surface of the ground by traveling over it during a season of rain. Regions which have survived close pasturage are very liable to be destroyed or greatly injured in this way. During the dry seasons the injury from trampling is nearly if not quite as great. Having no turf of leaves and no protection of shallow roots, the surface soil is easily cut and reduced to dust by animals moving over it in search of food and water.

#### FORMER CONDITIONS.

As an accurate knowledge of the conditions which once prevailed throughout these valleys and foothills was very essential to a proper and intelligent inauguration of range-improvement experiments, it was thought that the best plan would be an effort to restore the condition which once prevailed, for any extended attempts at cultural operations appeared entirely useless. It was thought that the greatest benefit to the range would be derived from rest, accompanied by reseeding with native forage plants. Accurate knowledge of previous conditions was therefore very essential. In order to obtain this information a circular letter, accompanied by a series of questions, was prepared by the writer, who was at that time botanist of the Arizona Experiment Station, and distributed to a selected list of correspondents. The letter and questions, reproduced below, are self-explanatory and indicate clearly the purposes of the inquiry. The answers returned agree almost perfectly and point to but one conclusion, namely, that the public ranges of the region were at one time comparatively productive and that their present condition has been brought about by overstocking.

#### CIRCULAR LETTER AND QUESTIONS.

MY DEAR SIR: The Arizona Experiment Station, in cooperation with the United States Department of Agriculture, is undertaking some experiments with a view of ascertaining the best methods of improving the native ranges of Arizona. Already the Department of the Interior, at the request of the Hon. James Wilson, Secretary of Agriculture, has reserved from entry for our use a tract of land in the vicinity of Tucson, and a suitable portion of this has been fenced. We are, therefore, practically ready to begin operations along lines suggested by the best experience of the officers of this station, as well as of the field agents and officers of the Division of Agrostology, United States Department of Agriculture. It is hoped and expected that this work will result in profit to the ranchers and stockmen of the Territory, and what results in profit to them results in profit to every citizen.

In order to undertake this work intelligently it is necessary to ascertain as accurately as possible the original condition of the range prior to its depletion by overstocking and prior to the excessive droughts of a few years ago, for it is by restoring the range to its original condition that we may hope to receive benefit



FIG. 1.—RAILROAD RIGHT OF WAY NEAR BENSON, ARIZ., SHOWING THE CONDITION OF THE RANGE UNDER PROTECTION.



FIG. 2.—WRIGHT'S SACCATON (*SPOROBOLUS WRIGHTII*).

The Santa Cruz bottoms near Tucson, Ariz., are said to have been covered with this grass.





and attain success in our range-improvement investigations. This information can only be furnished by reliable and experienced men who are conversant with the condition of the grazing lands of the Territory at the time when they yielded profit to the rancher.

You have been recommended to us as a person who, on account of your wide experience and abundant opportunity of observation, will be able to give us the information desired. We hope that you will be willing to assist us in this matter, in which we are all so deeply interested, by answering as many of the inclosed questions as you can at your earliest possible convenience, sending your answers to us in the inclosed addressed free envelope.

Very truly yours,

DAVID GRIFFITHS,  
*Special Agent in Charge of Cooperative Work.*

- 
1. With what portions of the Territory are you especially familiar?
  2. How long have you been acquainted with the regions spoken of in question 1?
  3. What was the relative abundance of the feed on the native range at the time you first became acquainted with it, compared with the present time?
  4. Will you please compare the grazing conditions in two or more regions with which you are familiar; for instance, the Santa Cruz, San Pedro, and Sulphur Spring valleys?
  5. Can you describe any specific instances of the destructive action of water in gullyng out the river valleys? Can you state how and at what time such gullyng started in any particular instance, and the extent to which the washing progressed in a given time?
  6. What influence has this gullyng had on the productiveness of the river bottoms?
  7. What grasses or other native forage plants furnish the greatest amount of feed at the present time in your vicinity? (If you do not know the names of these plants and are willing to send us samples, so state in answer to this question, and we will send you franks so that you can forward the same to us free of charge.)
  8. Do you attribute the present unproductive condition of the range to overstocking, drought, or to both combined? Please explain why.
  9. Will you please state the largest number of cattle which, in your opinion, have at any time grazed on any particular range with which you are acquainted, and at what time? What do you estimate is the present carrying capacity of the same range?
  10. Provided we should be able to furnish seed, would you be willing to put it in the ground in proper shape in some favorable situation on your place where cattle will not graze it for at least one year after planting? A very small patch would be required, say 50 feet square. Such an experiment would enable us to determine what forage plants are best adapted to your locality.

#### ANSWERS TO QUESTIONS.

The answers returned have been very suggestive and indicate an intelligent, active interest in the questions which are of such vital importance to the stock growers located on the public domain. Two of these, however, appear of such general excellence and indicate such a keen insight into the forage problems that they are reproduced in full. Col. H. C. Hooker, one of the earliest and most successful stock

raisers in the Territory, under date of December 11, 1900, writes as follows:

1. The southeastern.
2. Thirty-five years.
3. Fully double.
4. These regions have been diminished in grazing facilities fully 50 per cent in twenty-five years.
5. The San Pedro Valley in 1870 had an abundance of willow, cottonwood, sycamore, and mesquite timber, also large beds of saccaton and grama grasses, sagebrush, and underbrush of many kinds. The river bed was shallow and grassy and its banks were beautiful with a luxuriant growth of vegetation. Now the river is deep and its banks are washed out, the trees and underbrush are gone, the saccaton has been cut out by the plow and grub hoe, the mesa has been grazed by thousands of horses and cattle, and the valley has been farmed. Cattle and horses going to and from feed and water have made many trails or paths to the mountains. Browse on the hillsides has been eaten off. Fire has destroyed much of the shrubbery as well as the grass, giving the winds and rains full sweep to carry away the earth loosened by the feet of the animals. In this way many waterways have been cut from the hills to the river bed. There is now little or nothing to stop the great currents of water reaching the river bed with such force as to cut large channels and destroy much of the land under cultivation, leaving the river from 10 to 40 feet below its former banks. Thus it has caused much expense in bringing the water to the cultivated lands, and necessitated much labor to dam up the channel and keep the irrigating ditches in repair.
7. Gramas, saccatons, bunch, and six-weeks grasses.
8. Principally to overstocking. In times of drought even the roots are eaten and destroyed by cattle, while if not fed down or eaten out the roots would grow again with winter moisture.
9. There were fully 50,000 head of stock at the head of Sulphur Spring Valley and the valley of the Aravipa in 1890. In 1900 there were not more than one-half that number and they were doing poorly.
10. I will place 1 acre or more under fence on my land in any situation you may select for your experiments, providing you will superintend the planting and direct the cultivation, taking from my ranch such teams, farming tools, employees, etc., as you may require.

I am, respectfully yours,

H. C. HOOKER,  
*Proprietor Sierra Bonita Ranch.*

Mr. C. H. Bayless, of Oracle, Ariz., in addition to answering questions, submitted a statement containing a forcible expression of the futility of attempting to control the range without the help of the Government or the ranchers. It appears to the writer that the ranchers and those interested in stock growing are beginning to realize more and more the importance of placing the range management in the hands of some one having authority and an interest in its preservation. The objection to the control of the range is gradually wearing away. At least a dozen ranchers have expressed themselves to me within the past year in fully as emphatic terms as Mr. Bayless in his letter quoted below. With reference to range management Mr. Bayless writes as follows:

DEAR SIR: Within find answers to questions sent me. Permit me to add that no practical plan can well be advanced for increasing plant growth on any open



FIG. 1.—A CATTLE RANGE IN THE SANTA CATALINA MOUNTAINS, APRIL, 1901.



FIG. 2.—A FOOTHILL RANGE NEAR TUCSON, ARIZ., APRIL, 1901.



range while free for the use of everybody. Hence I must respectfully urge upon you the importance of impressing the Government officials with the fact that no general improvement of range country can be expected until the land is placed under individual control by lease or otherwise. In a few favored spots where such an arrangement is now secured through local conditions good results might be accomplished, but the greater part of our range country is at present a desert and will steadily become less and less productive, while the present range management, or rather lack of it, prevails.

Very respectfully yours,

C. H. BAYLESS.

- 
1. The San Pedro Valley and southern part of Pinal County.
  2. Fifteen years.
  3. At that time ten animals were kept in good condition where one can now barely exist. However, those ten animals were then rapidly destroying the vegetation, not making proper use of it.
  5. About twelve years ago the San Pedro Valley consisted of a narrow strip of subirrigated and very fertile lands. Beaver dams checked the flow of water and prevented the cutting of a channel. Trappers exterminated the beavers, and less grass on the hillsides permitted greater erosion, so that within four or five years a channel varying in depth from 3 to 20 feet was cut almost the whole length of the river. Every year freshets are carrying away new portions of the bottom lands. At present this valley is a sandy waste from bluff to bluff, while the few fields remaining are protected from the river at large and continuous expense. Thus, in addition to curtailing the area of good land, the deep channel has drained the bottoms, leaving the native grass no chance to recover from the effects of close pasturing. It also makes it more difficult to get irrigating water onto the surface of the land.
  7. Of the rich grama grasses that originally covered the country so little now remains that no account can be taken of them. In some parts of the foothills alfilaria furnishes limited but excellent pasture during the spring and early summer. Where stock water is far removed some remnants of perennial grasses can be found. Grasses that grow only from seed sprouted by summer rains are of small and transitory value. The foliage of the mesquite and catsclaw bushes is eaten by most animals, and even the various cacti are attempted by starving cattle. However, the thorns and spines of the cacti more than offset the value of the pulp. No better pasture was ever found in any country than that furnished by our native grama grasses, now almost extinct.
  8. The present unproductive conditions are due entirely to overstocking. The laws of nature have not changed. Under similar conditions vegetation would flourish on our ranges to-day as it did fifteen years ago. We are still receiving our average amount of rainfall and sunshine necessary to plant growth. Droughts are not more frequent now than in the past, but mother earth has been stripped of all grass covering. The very roots have been trampled out by the hungry herds constantly wandering to and fro in search of enough food. The bare surface of the ground affords no resistance to the rain that falls upon it and the precious water rushes away in destructive volumes, bearing with it all the lighter and richer particles of the soil. That the sand and rocks left behind are able to support even the scantiest growth of plant life is a remarkable tribute to our marvelous climate. Vegetation does not thrive as it once did, not because of drought, but because the seed is gone, the roots are gone, the soil is gone. This is all the direct result of overstocking and can not be prevented on our open range where the land is not subject to private control.
  9. Twelve years ago 40,000 cattle grew fat along a certain portion of the San

Pedro Valley where now 3,000 can not find sufficient forage for proper growth and development. If instead of 40,000 head 10,000 had been kept on this range, it would in all probability be furnishing good pasture for the same number to-day. Very few of these cattle were sold or removed from the range. They were simply left there until the pasture was destroyed and the stock then perished by starvation.

10. Yes, I will do so gladly. Object lessons of this kind will prove conclusively that overstocking, not drought, has made our country a desert.

C. H. BAYLESS, *Oracle, Ariz.*

#### FEED ON THE RANGE.

While each valley in the Territory has some characteristics distinctly its own, and while there is a great difference in the extent to which overpasturing has been carried on, there is still a certain similarity which is characteristic of the entire southern portion, namely, the preponderance during certain seasons of the year of weedy plants that would not ordinarily be considered fit food for cattle. During the year five typical valleys have been visited, namely, the Gila, Salt River, Santa Cruz, San Pedro, and Sulphur Spring. The opportunities for observation in the first two named were very meager, but still sufficient to bear out the testimony of several ranchers, that the only pasturage of any account in these two valleys during a large portion of the year consists of "browse." The main stock food on the open range appears to be derived from the mesquit and sage brushes (*Atriplex* spp.). These are supplemented in the winter and spring by weedy growths, and in the fall by annual grasses of transitory value. In the Santa Cruz Valley conditions are much the same on the open range, but in the Sulphur Spring Valley, which has a greater altitude, as well as a more copious precipitation, the perennial grasses still thrive. In some portions of this valley the natural conditions are such that the ranchers are able to control the range in such a manner as to protect it. No finer object lesson could be desired than the one furnished on the Sierra Bonita ranch, owned by Col. H. C. Hooker. This is located at the head of the valley, and the range is so situated between the Graham Mountains on the east and the Galiuro Mountains on the west that the entrance of cattle from neighboring ranches is easily prevented. Under such conditions, accompanied by good management, the range has been kept in a very good condition, compared with all the other portions of the region which the writer has visited. On this range large quantities of native grass are cut for hay. In one stack the following were recognized: Everlasting grass (*Eriochloa punctata*), *E. aristata*, *Chloris elegans*, *Eragrostis neomexicana*, vine mesquite (*Panicum obtusum*), *Aristida* spp. (in small quantities), Arizona millet (*Chaetochloa composita*), blue grama (*Bouteloua oligostachya*), low grama (*B. polystachya*), and *Andropogon torreyanus*. These, together with two or three species of *Sporobolus* (saccaton grasses) and the cultivated Johnson



FIG. 1.—TUFTED PLANTAIN (*PLANTAGO FASTIGIATA*) ON THE LEFT; BLUE GRAMA (*BOUTELOUA OLIGOSSTACHYA*) ON THE RIGHT.

Both figures from plants growing near Tucson, Ariz.

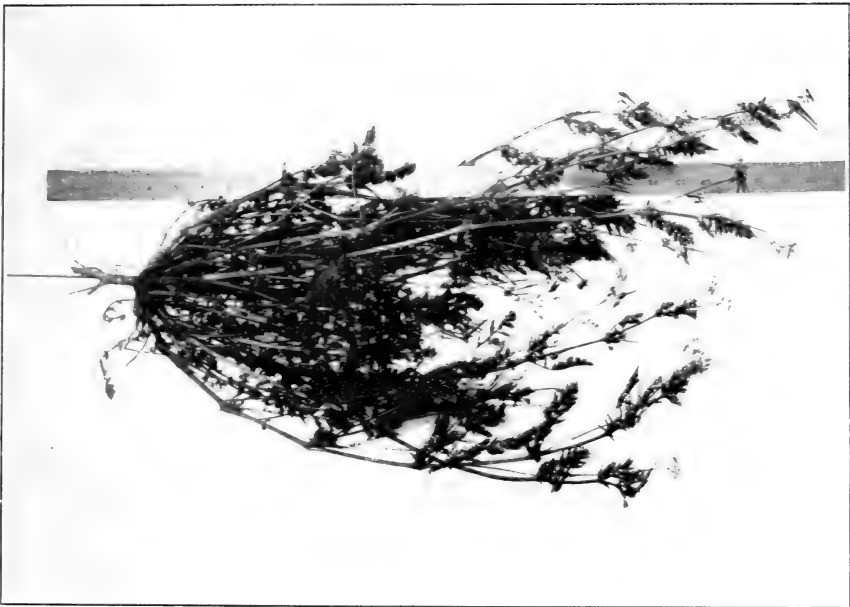
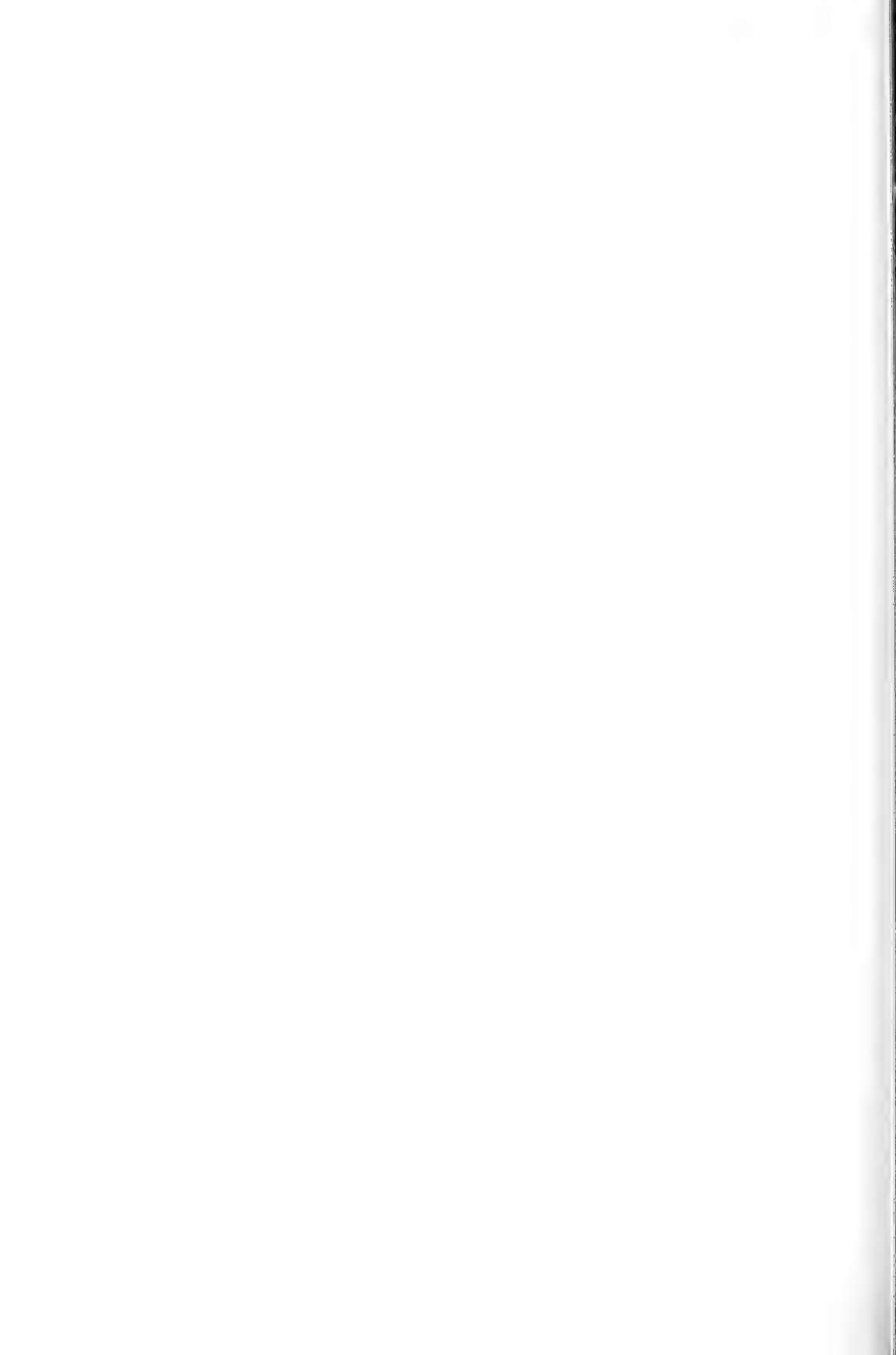

FIG. 2.—ALFILARIA (*ERODIUM CICUTARIUM*), GROWN ON THE UNIVERSITY CAMPUS AT TUCSON, ARIZ.





grass, form the main hay grasses on the range. In some localities the galleta grasses (*Hilaria mutica* and *Hilaria jamesii*) furnish large quantities of coarse hay, which, as one liveryman expressed it, is used to "chink" in with. The condition of the vegetation in the San Pedro Valley, while much superior to that of the Santa Cruz, is much inferior to the Sulphur Spring.

#### THE PLANTAINS.

These plants, of which the Indian wheat (*Plantago fastigiata* Morris) is the most important and which formed the greater part of the feed on the range in the vicinity of Tucson in the spring of 1901, are popularly known as Indian wheat and are very abundant after winter rains all through southern Arizona, especially in the lower altitudes. They are also found commonly at considerable elevations in the mountains, but are not sufficiently abundant there to be of any economic importance. On the lower moister areas of the general mesa region, however, the crop is often quite large. The fenced portion of our range reserve afforded an excellent opportunity for studying these plants during the past season. It is usually impossible to appreciate their entire forage value upon the open range on account of the present short pasturage. During the past season there was considerable difference in the quantity of these plants found inside and outside of our fenced area, although the feed is reported to have been more abundant than usual and the stock on the range to have been much reduced in recent years.

At the suggestion of Director R. H. Forbes an attempt was made to ascertain the precise amount of feed which these plants furnished on our range reserve tract during the past season. The estimate is believed to be approximately accurate and to give a very fair idea of the amount which grows in similar localities in rather favorable years. The estimate was made from actual measurements of representative areas selected by myself after a careful survey of the entire fenced area. A die 15 feet long by 3 feet wide was prepared as accurately as possible. All plantains covered by this were pulled up. After having the roots cut off they were placed in a bag and dried in the sun. Eighteen such areas were measured and treated in the same way. The weight of this material collected on the 26th and 27th of March became constant early in May, indicating that it was thoroughly dried. The final weights were then taken. The data given below indicate not only the amount of forage, but also the character and diversity of product of the reserve tract. The figures on the plat (p. 22) corresponding with the samples in the tabulation given below, indicate the localities where measurements were made. From these an idea of the relative productivity of the different situations can be readily obtained. It will be seen that the smallest growth

occurred in the higher areas, occupied principally by the creosote bush (*Larrea mexicana*).

Number of plat.	Weight of dry material per acre.	Number of plat.	Weight of dry material per acre.	Number of plat.	Weight of dry material per acre.
	<i>Pounds.</i>		<i>Pounds.</i>		<i>Pounds.</i>
1.....	1,184	7.....	342	13.....	152
2.....	16	8.....	76	14.....	388
3.....	1,160	9.....	1,286	15.....	2,466
4.....	1,139	10.....	1,036	16.....	153
5.....	2,347	11.....	56	17.....	1,594
6.....	1,079	12.....	3,087	18.....	300

By comparison with the diagram on page 22, it will be seen that the smaller weights in the table indicate areas where the creosote bush predominates. These average the smallest in quantity, varying from 16 to 2,466 pounds per acre. An average of these plats gives a yield of 992 pounds or practically one-half ton per acre, or 166½ tons for the entire 336 acres under fence. The value of this material for stock food must be determined by actual feeding tests and chemical analysis. This the Station is now planning to determine. It may be said, however, that Indian wheat forms a large part of the feed on the range during late winter and spring, and that cattle pastured on it and alfalaria, while not in as good condition as those fattened on the ranges of the Northwest, were still in fair condition for the market.

These plantains appear especially well suited to grow on the sandy desert mesa, where winds and destructive floods are liable to carry away the seed. The method of seed distribution is indeed unique and one of the most interesting the writer has ever seen. As far as observed there appears to be no special method for scattering the seeds, but when the capsule is ruptured they fall, being scattered only by chance influences of vegetation and wind. Each seed is surrounded by a hyaline mucilaginous covering which is ordinarily inconspicuous when the seed is dry. When the seeds scattered over the surface of the ground are moistened, as by a shower of rain, this covering swells, becomes mucilaginous, and attaches itself temporarily to particles of earth or to whatever it comes in contact with. After becoming thoroughly moistened the seed gravitates to the bottom of the mucilaginous covering and rests upon the supporting soil. Upon the evaporation of the absorbed moisture the mucilage dries in such a way as to leave the seed in the bottom of a small pit in the ground. This depression has usually a diameter about three times that of the seed and a depth equal to or slightly greater than the distance between its flat surfaces. The abrading of the surface during the subsequent two to five months, during which the seeds lie dormant, serves to effectually cover them, so that they are ready for germination upon the advent of the summer rains. Just what the mechanism is



FIG. 1.—SHAD SCALE (*ATRIPLEX CANESCENS*) IN FENCED FIELD NEAR TUCSON, ARIZ.



FIG. 2.—CATTLE FED ON TUFTED PLANTAIN (*PLANTAGO FASTIGIATA*) AND ALFILARIA (*ERODIUM CICUTARIUM*) ON WAY TO MARKET, MAY, 1901.



which serves to sink the seed into the ground has not been determined by this study. When moistened the gelatinous covering has a distinct radial, striated structure, and the surface of the pit would indicate that in some way the earth is pulled away from the seed, thereby allowing it to sink into the ground. The process is so effectual as to cause the seed to be sunk even in hard roadbeds as well as upon the general surface of the mesa. A study of this problem for the purpose of determining exactly the influence of this mucilaginous covering in the burial of the seed would throw considerable light upon the development of these plants in unfavorable desert regions, and doubtless add something to our knowledge of seed distribution. The amount of seed produced in the spring of 1901 was exceedingly large. Considerable areas on our range reserve were completely covered with it. A shower of rain on the 26th of May served to make it very conspicuous. Naturally every cow track, gopher hole, and other depression was filled with it. When the rain fell these masses of seed became firmly united together, sometimes into thin crusts and sometimes into masses 3 inches or more in thickness. Upon drying the mesa presented a peculiar appearance, for these cakes curled in much the same manner as a muddy deposit on the bottom of a dried-up pool. Many localities have been seen where a third of the ground was covered for an acre or more in extent with cakes of this seed. When moistened in large masses a crust was invariably formed on the top and bottom in a short time after the shower passed by. In both crusts the seeds were relatively abundant. In the upper crust this appeared to be due to rapid drying, but in the lower one it was evidently due to gravitation, whereby the seeds were deposited on the bottom, where they were incrustated with particles of earth, leaving the mucilage more nearly pure in the center of the mass.

Mr. James Goodwin, of Tempe, reports that the seeds of these species of plantain are largely used for food by the various Indian tribes of Mexico. A beverage is prepared by soaking the seeds in water and sweetening with sugar. In this way a sirupy liquid is obtained which is said to be very nutritious.

#### SALTBUSHES AND THEIR ALLIES.

These "browse" plants are popularly known as sage brush in Arizona, although very different from the artemisias of the Northwest, which are referred to by the same name. Every rancher is acquainted with this portion of the stock feed of the region, but it has appeared to me that its full value is not appreciated. The most important of the species observed is shad scale (*Atriplex canescens*), although several others, both of the perennial and annual groups, occur in large quantities. These are grazed to a greater extent in the Santa Cruz Valley than in any other region visited. Here it is

very seldom that one encounters a plant over 2 or 3 feet high on the open range, while in protected places bushes 10 feet high may often be seen. Large areas of a luxuriant growth of these plants were formerly found along the Santa Cruz River, where now only short stumpy growths 10 or 12 inches high are to be found. It is on the plains to the westward and in the Gila and Salt River valleys, however, that these plants grow in the greatest profusion. Here, as the writer's observation goes, they are but slightly injured by grazing. This appears especially true in the vicinity of Tempe. In one locality on the Gila, however, as well as at Tombstone, in the San Pedro Valley, close cropping of shad scale was the rule.

The propagation of the native species of *Atriplex* has been attended with considerable difficulty, but some plantings made on the range in January have proven very successful. In the case of shad scale, which appears to be the most promising of any of the native species, the seed collected by various field agents of the Division in the Northwest have usually failed to germinate. This was also the case with seed collected in Arizona early in September of 1900. The same material collected a month later germinated readily. The difference could not be one of local conditions or difference of treatment, because these conditions were identical and the same results were obtained on the range and in germination tests in the greenhouse. A favorable time for collecting seed of the native species which occur in this region is late October to January. It will probably grow just as well if collected in late October as at any other time, but gathering can be done to better advantage later in the season, because the seeds strip off more readily and require less drying—circumstances of considerable importance to the seed collector. In the moister alkaline regions the greasewood (*Sarcobatus vermiculatus*) is often found in abundance, but observation indicates that it is not browsed as much as one would expect. It is certainly a much inferior food to the saltbush. Winter fat (*Eurotia lanata*), on the contrary, appears to be nearly exterminated on the open range. Two or three bushels of seed could have been gathered on the railroad right of way between Dragoon and Cochise in October, but on the open range only two or three closely cropped bushes were to be found. This is the only place in which the plant has been collected.

#### NATIVE LEGUMES.

The most important plant among the legumes is the mesquit (*Prosopis velutina* Wootton?<sup>1</sup>). The screw bean (*P. pubescens*) is also common, but it never grows in such profusion as the other closely related

<sup>1</sup>The prevailing species in southern Arizona has been referred to *P. juliflora*. It is not, however, the same plant that is referred to this species in Texas and the greater part of New Mexico. The Arizona plant corresponds closely in everything but fruit characters to *P. pubescens*.

species. So much has been written regarding the forage value of this plant that but little need be said in this place. In this region it forms much of the feed during the hard times, not only in spring and early summer while it is succulent and green, but also in the winter, when it would be ordinarily considered worthless. During the past winter, when the pastures along the Santa Cruz were very short, not only the pods but the leaves of this tree as well were eaten by cattle. Numerous instances were observed where the leaves as they fell from the trees were completely cleaned up in large areas in the thick mesquit groves of the region.

Besides the mesquit there are several species of *Acacia* which are browsed to some extent. The leaves of these are also eaten after they have fallen in much the same manner as the mesquit during times of short feed. Many species of *Lupines*, *Horsackias*, and *Astragalus* abound and furnish a large part of the feed on the moister mesas and foothills for a short time in the spring. *Astragalus nuttallii*, which is the common species in the moister mesa region, is worthy of special mention. It is readily eaten and under favorable conditions furnishes much palatable feed. Several small areas on the range reserve tract had a complete covering of this plant during the past spring. It is a small plant, but has the advantage of forming such a dense growth as to completely cover the ground. Its seeds are also comparatively easily collected. If gathered before fully ripe the whole plant with its abundant seed supply can be collected, but if left until the herbage is dead and dry the pods can be scraped up from the ground with little, if any, loss of seed.

#### THE CACTACEÆ.

The cactuses look very uninviting to the average stock raiser, but they, nevertheless, are of some value and are resorted to in times of great necessity. During the past winter at least a half dozen instances were observed of the actual eating of these plants by cattle. The species most frequently made use of in the vicinity of Tucson are *Opuntia fulgida*, *O. spinosior*, *O. versicolor*, and *O. arbuscula*. The two named first produce an abundance of fruit which is free from large spines. The former has many bunches of small fruit, while the latter has large fruits borne singly. One may often during a hard winter observe cattle having a dozen or more joints of this species attached to their heads and necks. Usually these joints remain in these positions until they are rubbed off or until they fester and drop out of their own accord. Fragments of these plants break off very readily, and cattle reaching under the joints to obtain the fruit are almost certain to come in contact with one or more of them.

Knowing of the experiments conducted in Texas of feeding these plants (*O. engelmanni* especially), in January, the experiment of singeing the spines as thoroughly as possible from a portion of a medium-

sized specimen of *O. spinosior* was tried. About one-third of the plant was left unsinged. Ten days later, when the locality was again visited, the singed portion had all been eaten down to the old hard wood. As near as could be judged the greater part of three years' growth had been eaten. The cattle were doubtless attracted by the small quantity of hay (used in the singeing) that was scattered over the ground. It is well known that these plants, at certain times of the year at least, are very rich in starch, and for that reason may be more nutritious than one would be led to believe. To what extent this form of vegetation, so abundant on the mesas of this region, can be utilized as cattle food in time of scarcity is not known. Neither is it known whether the plants will survive the singeing process. Two experiments were started for the purpose of determining the latter point, but engagements compelled the writer to leave the region before any conclusion could be reached. The singeing of the giant cactus (*Cereus giganteus*) is said to have been a common practice among the Indians in former times. By lighting the spines of the giant *Cereus* they gave momentary signals to their friends in the distance. Many of these plants with burned spines were encountered during the the past season in full bloom and in apparently healthy condition. Whether the other species will bear the same treatment remains to be determined. It is certain that the spines alone prevent their being eaten more extensively by cattle.

#### THE GRASSES.

As usual in every range the grasses form the bulk of cattle food. Other plants are more or less important, because they serve the very useful purpose oftentimes of tiding over periods of short pasturage. While the bulk of the feed in many localities for the greater part of the year is obtained from the grasses, the other vegetation mentioned above serves the very vital purpose of furnishing a subsistence ration when the more nutritious and palatable grasses fail entirely. It is for this reason that the species of *Plantago*, *Atriplex*, and *Erodium* are of so much importance and the *Cactaceæ* are mentioned as being of possible utility.

At the present time perennial grasses are rarely found on the general mesa in the Santa Cruz Valley in the vicinity of our experimental tract, unless it be in an occasional stray bunch protected by the thorns of the mesquit or the spines of the cactus. In the protected places along the river bottoms are still found excellent growths of saccaton (*Sporobolus wrightii*). This has been to a large extent exterminated in recent years for agricultural purposes, so that the only places in which it is found at the present time are in an occasional pasture or in uncultivated portions of fenced fields. It is one of the most persistent of the native species of the region. The woody character of the culms prevents its being grazed closely, which, no doubt, has



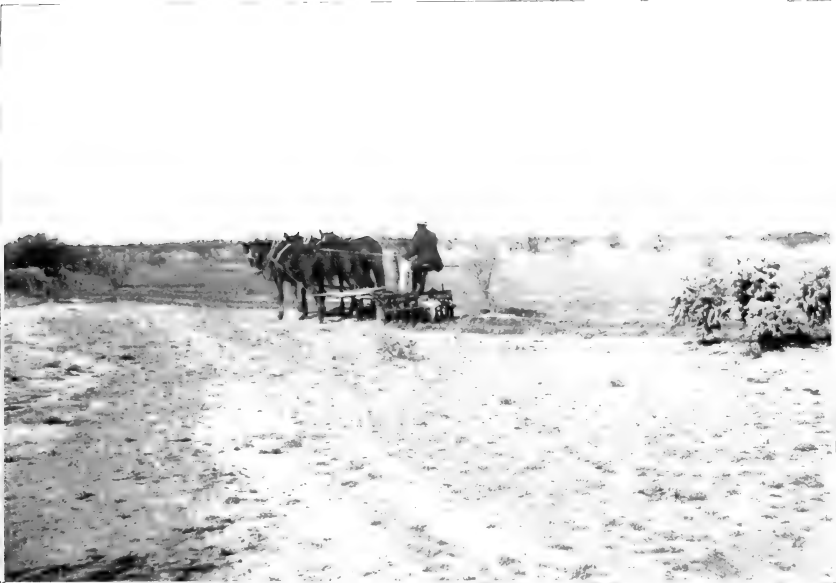

FIG. 1.—OPERATIONS IN RANGE IMPROVEMENT NEAR TUCSON, ARIZ., JANUARY, 1901.



FIG. 2.—RANGE RESERVE TRACT NEAR TUCSON, ARIZ., SHOWING A TYPICAL CREOSOTE-BUSH (*LARREA MEXICANA*) LOCALITY.





FIG. 1.—CACTUS ('OPUNTIA ARBUSCULA' FROM RANGE RESERVE TRACT NEAR TUCSON, ARIZ.

The fruit is eaten by cattle during short pasture.



FIG. 2.—CACTUS (OPUNTIA FULGIDA). A BUNCH OF PENDANT FRUIT AND ONE JOINT.

In extreme cases of hunger cattle feed on this fruit.



much to do with its persistency under heavy pasturing. It has been reported to me that the expense of clearing a piece of ground of saccaton is as great as the clearing of an equal area of mesquit timber. The feed from this source is very coarse and is usually considered of an inferior quality, but, like the saltbushes, it furnishes feed when nothing else can be found. Of similar utility is the salt grass (*Distichlis spicata*), which is grazed to a large extent during seasons of short feed. It is much inferior in feeding quality to the saccaton. During the dry season of 1900 it is said to have saved many herds of cattle from starvation in the Sulphur Spring Valley, where there are thousands of acres of it and where either from the effect of alkali or overstocking nothing else grows. On sandy portions of the river bottoms may be found considerable quantities of drop-seed (*Sporobolus cryptandrus*), *S. strictus*, and Arizona millet (*Chætochloa composita*).

The most important nutritious grasses which predominate on the open mesa range are black grama (*Hilaria mutica*), *H. jamesei*, curly mesquite (*H. cenchroides*), blue grama (*Bouteloua oligostachya*), low grama (*B. polystachya*), woolly-foot (*B. eriopoda*), side oats grama (*B. curtipendula*), and black heads (*Pappophorum wrightii*). In depressions where water accumulates after summer rains good growths of *Chloris elegans*, everlasting grass (*Eriochloa punctata*), vine mesquite (*Panicum obtusum*), *P. colonum*, and *Eragrostis neomexicana* are found. In such moist localities, where close pasturing is not the rule, there may usually be found also fine growths of feather grass (*Andropogon torreyanus*). This grass, however, is never seen on the unprotected range in any quantity. Large areas were encountered on the railroad right of way in the vicinity of Cochise in 1900. On the open range one seldom finds it, except where protected by the thorns of the mesquite or spines of the cactus. On the general mesa, where the soil does not wash badly, there are invariably found large quantities of six weeks grama (*Bouteloua aristidoides*) after the summer rains. This species, known popularly as six-weeks grass, furnishes a great deal of excellent feed for a short time. Besides the above should be mentioned several species of *Muhlenbergia* and *Aristida*, which for short periods furnish much feed of an inferior quality. The preceding description would apply fairly well for 1900 to the Sulphur Spring Valley. The quantity diminished gradually to the westward as far as Tucson, where, although the species mentioned above were commonly found, there was but little feed furnished by the native grasses. During the second week in October large areas on the gentle slopes near the foothills in the San Pedro Valley were very fairly covered with short growths of *Bouteloua aristidoides*, *B. polystachya*, *Pappophorum wrightii*, and *Nazia aliena*.

The adaptability of the grasses, as well as the other vegetation in this region to conditions of environment, is something wonderful. Variation in size as the direct influence of quantity of moisture is often

very marked. *Chloris elegans*, which commonly grows 2 feet high, may be often found on the drier mesas in scattering specimens maturing perfect seed when the whole plant above ground measures no more than an inch and a quarter in length. Six-weeks grama (*Bouteloua aristidoides*) is often reduced from the maximum of 12 inches in

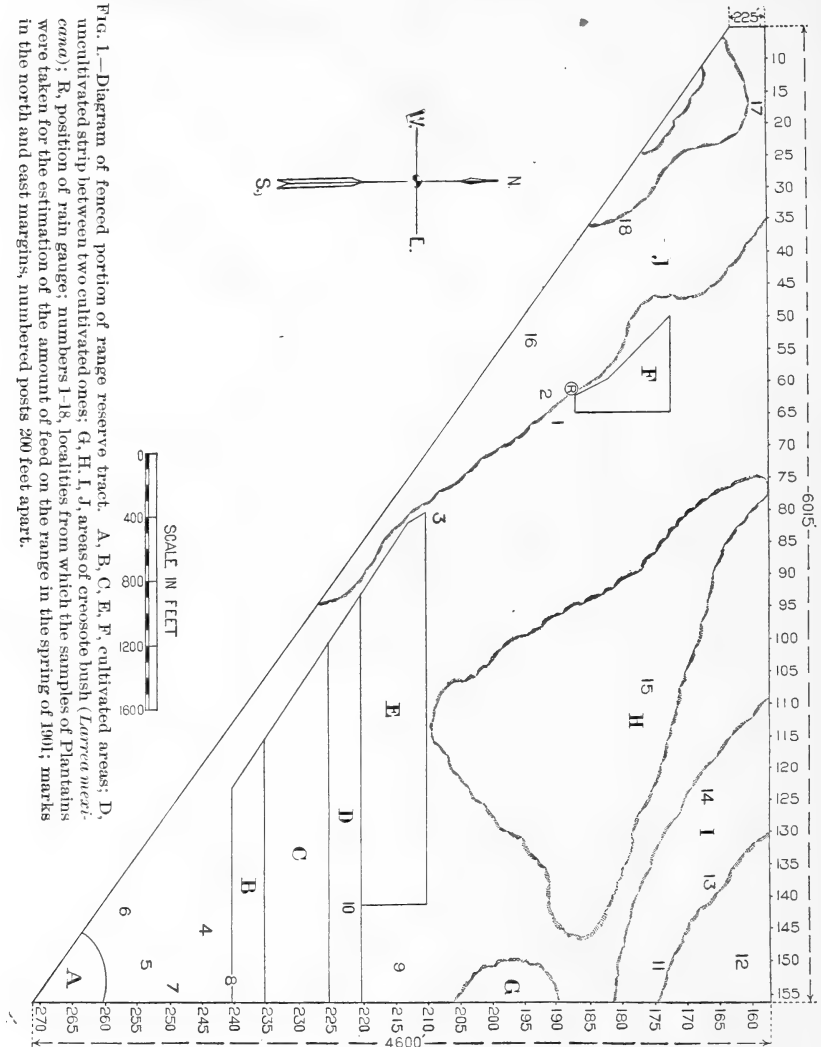

FIG. 1.—Diagram of fenced portion of range reserve tract. A, B, C, E, F, cultivated areas; D, uncultivated strip between two cultivated ones; G, H, I, J, areas of creosote bush (*Larrea mexicanus*); K, position of rain gauge; numbers 1-18, localities from which the samples of plants were taken for the estimation of the amount of feed on the range in the spring of 1901; marks in the north and east margins, numbered posts 200 feet apart.

height, with a dozen or more branches, to a single culm three-fourths of an inch long, maturing but one or two spikelets. Corresponding variations in size are especially noticeable in all of the annual species.

The mountain range presents a very characteristic appearance.

Receiving as it does a more liberal supply of moisture, the development is more uniform during the growing season. Even here no sod is formed, indeed no sod could usually be formed if the moisture conditions were ever so favorable, for the presence of loose jagged rocks, with the exceedingly rugged conditions, would almost compel the growth of grasses in small bunches. The grasses which form the main feed in such localities, and therefore the most conspicuous of this portion of the vegetation, are *Andropogon contortus*, *A. leucopogon*, *Trachypogon secundus*, *Elionurus barbiculmis*, *Hilaria* sp., *Bouteloua bromoides*, *B. oligostachya*, *B. curtipendula*, *Trioda mutica*, *Eragrostis lugens*, *Muhlenbergia gracillima*, *M. porteri*, *Epicampes rigens*, and *Aristida* sp. These regions are often so inaccessible that stock can not reach them. They are therefore more nearly primitive than the mesas, and one is able to get a better idea of their productivity.

#### THE RANGE RESERVE TRACT.

The range improvement work in Arizona being of a different character from that usually contemplated, and being in a region more completely divested of range grasses than any other in the entire country, required considerable careful study in advance to discover the proper locality for experimentation. Accordingly, the greater part of a week was spent in a survey of the surrounding country in the vicinity of Tucson for the purpose of determining which of the three typical areas (mesa, foothill, or river bottom) would be the most favorable and give the most conservative and valuable data upon which to base judgment of the results obtained by experimentation. Finally a rather favorable mesa area was selected at an altitude of about 2,600 feet above sea level and about 400 feet higher than the city of Tucson. This tract, which was subsequently reserved from entry at the request of the Hon. James Wilson, Secretary of Agriculture, is described in the Government surveys as secs. 26, 27, 34, and 35, T. 14 S., R. 14 E., Gila and Salt River meridian.

Somewhat diagonally through the center of this area runs the Southern Pacific Railway, and a short distance to the east of it is located Wilmot Siding. The soil is a clay loam, mixed with considerable sand, and subtended at a depth of 2 to 2½ feet by a calcareous hardpan, known among the Mexicans by the significant name "caliche." The slope, which is rather gentle, has a general northwesterly direction, and is traversed by three more or less distinct, broad, shallow depressions, which receive the drainage of a considerable area of land to the southeast. Such a region, with broad, shallow washes, was purposely selected. It was the intention to attempt to conserve water flow on the mesa, and to discover what can be done toward preventing "run-off" of water during the rainy season of July and August. Such washes, although the most favorable for the growth of vegetation of all kinds,

are nevertheless typical of large tracts of desert, not only in the Santa Cruz, but in the San Pedro, Gila, and Salt River valleys as well.

A triangular portion of this reservation, consisting of 336 acres adjoining the Southern Pacific right of way, has been placed under a substantial four-wire fence supported on singed mesquite posts 13½ feet apart. The area encompasses nearly all the varieties of exposure, drainage, and soils, and is, in short, a typical mesa region in every respect. The advantage taken of the railway fence enabled us to inclose the tract at a minimum cost. Two miles of fence, at an approximate cost of \$150 a mile, covers practically the entire expense of the inclosure.

When selected, this tract of land, like the surrounding region, furnished practically no feed; the ground was bare, except for cacti and shrubby growths of little or no forage value. On the higher and poorer soils are found characteristic growths of the creosote bush (*Larrea mexicana*), around the base of which is almost invariably found *Perezia nana*, which, unlike the vast majority of desert plants, possesses a very pleasant odor. Scattered over the entire area are to be found luxuriant growths of cacti, mainly of the genus *Opuntia*. The main species of this family are *O. fulgida*, *O. spinosior*, *O. arbuscula*, *O. engelmanni*, *Cereus fendleri*, *C. greggii*, *Echinocactus wislizeni*. All of the lower areas have scattering growths of mesquite (*Prosopis velutina*), palo verde (*Parkinsonia torreyana*), *Zizyphus lycoides*, *Lycium* sp., *Riddellia cooperi*, *Bigelovia* sp., and *Ephedra trifurca*. A few specimens of *Yucca elata* are also to be found. These plants formed the conspicuous portion of the vegetation in September, when the land was bare, and there was no grass except an occasional tuft of six-weeks' grass (*Bouteloua aristidoides*) and low grama (*Bouteloua polystachya*). Soon after this date the tract assumed a more promising aspect, and weedy growths of various kinds began to spring up after the very light summer rains. It was not until January, however, that the vegetation became marked. From this time on until the 1st of March there was an abundant development of short-lived annuals. The most conspicuous of these was the California poppy (*Eschscholtzia mexicana*), which was so abundant in localities here and in other portions of the valley as to give its characteristic golden hue to the entire landscape, sometimes for many acres in extent. The next in abundance was Indian wheat (*Plantago fastigiata*), of which a description will be found elsewhere (p. 15). Besides these, there were a great many borages, which were often the characteristic vegetation over large areas. The principal genera of this family represented were *Pectocarya*, *Echidiocarya*, *Amsinkia*, *Echinosperrum*, and *Eretrichium*. Among other conspicuous plants may be mentioned *Malacothix glabrata*, *Chænactis lanosa*, *Daucus pusillus*, *Bowlesia septentriolis*, *Erodium cicutarium*, *E. texanum*, *Salvia columbariae*, and the peculiar *Oenothera scapoidea*. In a few



localities conspicuous growths of the prickly poppy (*Argemone platyceras*) were to be seen. The latter was quite persistent and continued to bloom until June.

In this description no attempt is made to give a list of the plants growing on the fenced area. A sufficient number is given to show the character of the vegetation in the different seasons.

By the 1st of April the majority of the winter annuals were dried up, and a month later they were all quite dead and their seed had been scattered, so that all that was necessary to make the region look as it did the previous fall was to have the cattle eat off the dead herbage, which they were rapidly doing on the outside of the fence.

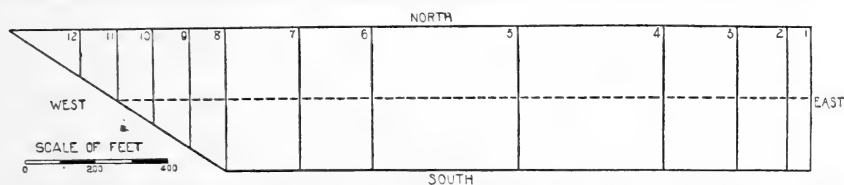

FIG. 2.—Diagram of Area C. The figures indicate the position of the stakes in each plot; broken line, separation between disked and harrowed portions.

The following detailed account of the forage plants planted is presented for comparison with figures 2, 3, 4, and 5, respectively.

#### AREA C.

Operations were begun on this plat on the 10th of January, immediately after a rainfall of 0.42 inch. After seeding the north half was disked and the south half harrowed directly east and west. The ground was conspicuously ridged by the disk harrow, and the seed was consequently covered to varying depths. Subsequent showers showed beyond a doubt that this ridging was an advantage in preventing a run off of water. The area is 400 feet in width by 2,200 feet in its greatest length. It measures  $17\frac{1}{2}$  acres and contains plats 1 to 12, on which were planted seed, as follows.

Number of plat.	Name of forage plant sown.	Seed, native or foreign.	Area of plat.
			<i>Feet.</i>
1.....	<i>Chloris elegans</i> .....	Arizona.....	400 by 60
2.....	Nothing sown.....		400 by 140
3.....	<i>Chloris elegans</i> .....	Arizona.....	400 by 40
4.....	.....do.....	.....do.....	400 by 40
5.....	<i>Andropogon saccharoides</i> .....	.....do.....	400 by 400
6.....	<i>Agropyron spicatum</i> .....	Northwest.....	400 by 200
7.....	<i>Agropyron occidentale</i> .....	.....do.....	400 by 200
8.....	<i>Hilaria mutica</i> .....	Arizona.....	400 by 100
9a.....	<i>Bromus unioloides</i> .....	(?).....	350 by 100
10a.....	<i>Bromus marginatus</i> .....	Idaho.....	200 by 100
11a.....	<i>Pappophorum vaginatum</i> .....	Arizona.....	150 by 100
12a.....	<i>Eurotia lanata</i> .....	.....do.....	100 by 100

<sup>a</sup> The areas given for plats 9 to 12 are only approximate, for they, taken together, form a triangle, and the exact length of each plat has not been determined.

AREA E.

This area, like C, extends directly east and west. The west half, consisting of plats 13 to 32, was sown without previous preparation of the ground. The south half of this portion was then disked and harrowed east and west, and the north half harrowed twice in the same direction. The east half, consisting of plats 60 to 75, was disked in an east and west direction before being planted and afterwards harrowed north and south. The entire area measures 400 feet in width by 2,400 feet in its greatest length, and contains 19½ acres. The seed planted here were as follows:

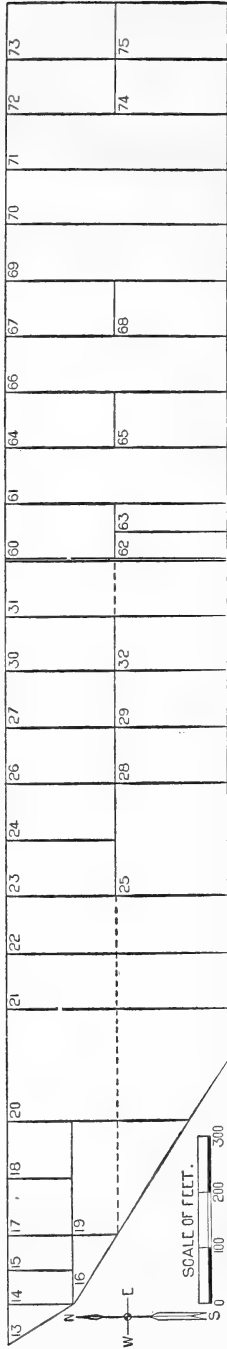

FIG. 3.—Diagram of Area E. The figures indicate the position of the numbered stakes in each plat; broken line, separation between harrowed and disked portion of west half; double line, west edge of portion disked before seeding.

Number of plat.	Name of forage plant sown.	Seed, native or foreign.	Area of plat.
			<i>Feet.</i>
13 a	<i>Aristida bromoides</i>	Arizona	100 by 75
14 a	<i>Aristida humboldtiana</i>	do	110 by 62½
15 a	<i>Muhlenbergia gracilis</i>	do	110 by 62½
16 a	<i>Stipa</i> spp	New Mexico	100 by 60
17 a	<i>Chaetochloa composita</i>	Arizona	100 by 110
18 a	<i>Melinis minutiflora</i>	Brazil	100 by 110
19 a	<i>Bromus unioloides</i>	Australia	100 by 200
20 a	<i>Eriocoma cuspidata</i>	(?)	400 by 200
21	<i>Sporobolus wrightii</i>	Arizona	400 by 100
22	<i>Sporobolus</i> (near <i>wrightii</i> )	do	400 by 100
23	<i>Sporobolus cryptandrus</i>	Colorado	200 by 100
24	do	Arizona	200 by 100
25	<i>Sporobolus airoides</i>	Wyoming	200 by 200
26	<i>Bouteloua polystachya</i>	Arizona	200 by 100
27	<i>Bouteloua curtipendula</i>	do	200 by 100
28	<i>Bouteloua humboldtiana</i>	New Mexico	200 by 100
29	<i>Bouteloua eriopoda</i>	Arizona	200 by 100
30	<i>Bouteloua aristidoides</i>	do	200 by 100
31	{ <i>Bouteloua polystachya</i> <i>Chloris elegans</i> }	do	400 by 100
32	<i>Bouteloua oligostachya</i>	do	200 by 100
60	<i>Elymus simplex</i>	Wyoming	200 by 100
61	<i>Elymus canadensis</i> var	(?)	400 by 100
62	{ <i>Poa fendleriana</i> <i>Bouteloua eriopoda</i> }	New Mexico	200 by 50
63	{ <i>Elymus ambiguus</i> <i>Poa lucida</i> }	Montana?	200 by 50
64	<i>Elymus condensatus</i>	do	200 by 100
65	<i>Elymus virginicus submuticus</i>	Washington	200 by 100
66	<i>Agropyron tenerum</i>	(?)	400 by 100
67	<i>Agropyron spicatum</i>	Washington	200 by 100
68	<i>Agropyron occidentale</i>	(?)	200 by 100
69	<i>Bouteloua oligostachya</i>	Arizona	400 by 100

a The measurements of plats 13 to 20 are only approximate.

Number of plat.	Name of forage plant sown.	Seed, native or foreign.	Area of plat.
70.....	<i>Bouteloua polystachya</i> .....	Arizona.....	400 by 100
71.....	<i>Bouteloua bromoides</i> .....	New Mexico .....	400 by 100
72.....	<i>Hilaria cenchroides</i> .....	Washington, D.C. ....	200 by 100
73.....	<i>Eragrostis neomexicana</i> .....	Arizona .....	200 by 100
74.....	<i>Bromus polyanthus paniculatus</i> .....	New Mexico .....	200 by 100
75.....	{ <i>Phaseolus retusus</i> .....	.....do .....	200 by 100
	{ <i>Phleum asperum</i> .....	Washington .....	

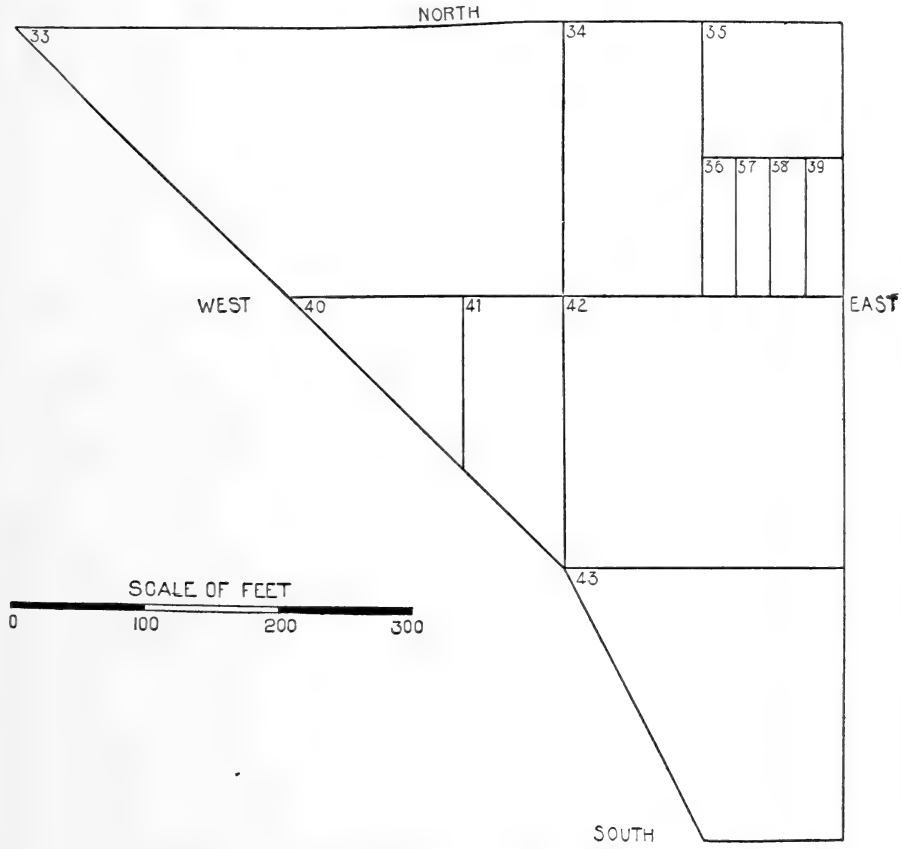

FIG. 4.—Diagram of Area F. The figures indicate the position of the numbered stakes in each plat.

AREA F.

This was devoted entirely to saltbushes, except that in a few plats seeds of native grasses were also sown. The area is located on the edge of one of the broad, shallow washes and is laid out roughly triangular, so that the measurements given for some of the individual

plats are only approximate. It consists of plats 33 to 43 and contains nearly 4 acres. The cultivation here was more thorough than in either C or E. The saltbush seed was sown on the uncultivated soil. The ground was then disked north and south and east and west. The grass seed was then sown, after which the entire area was harrowed diagonally. Seed of saltbushes was planted in plats as follows:

Number of plat.	Name of forage plant sown.	Seed, native or foreign.	Area of plat.
			<i>Feet.</i>
33.....	<i>Atriplex canescens</i> .....	Tucson, Ariz.....	200 by 300
34.....	do.....	Tempe, Ariz.....	200 by 100
35.....	<i>Atriplex</i> sp.....	do.....	100 by 100
36.....	<i>Atriplex canescens</i> .....	Wyoming.....	100 by 25
37.....	<i>Atriplex erenicola</i> .....	do.....	100 by 25
38.....	<i>Atriplex nuttallii</i> .....	do.....	100 by 25
39.....	<i>Atriplex volutans</i> .....	do.....	100 by 25
40.....	<i>Atriplex halimoides</i> .....	do.....	100 by 125
41.....	{ <i>Elymus canadensis</i> .....	(?).....	} 175 by 75
	{ <i>Atriplex halimoides</i> .....	Australia.....	
42.....	{ <i>Eriocoma cuspidata</i> .....	New Mexico.....	} 200 by 200
	{ <i>Atriplex</i> sp.....	Tempe, Ariz.....	
43.....	{ <i>Bouteloua oligostachya</i> .....	Arizona.....	} 200 by 150
	{ <i>Atriplex semibaccata</i> .....	California.....	

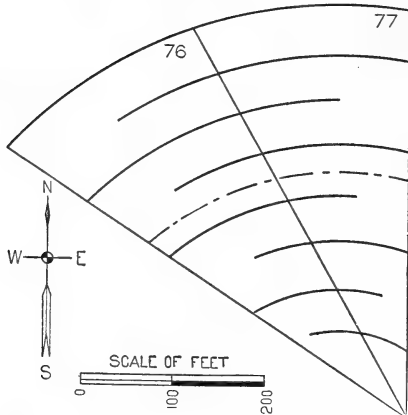

FIG. 5.—Diagram of Area A. The figures indicate positions of numbered stakes; broken arc, limit of area twice disked before seeding; continuous arcs, ridges approximately 50 feet apart to prevent run off of water.

*Plat 76.*—*Agropyron tenerum*, *Chloris elegans*, *Bouteloua oligostachya*, *Sporobolus airoides*, *Elymus canadensis*, *Eriocoma cuspidata*, *Sporobolus cryptandrus*, *Agropyron occidentale*, and *Phaseolus rutilus*.

*Plat 77.*—*Andropogon saccharoides*, *Chloris elegans*, and *Bouteloua oligostachya*.

#### AREA A.

This area, consisting of two triangular plats, Nos. 76 and 77, contains nearly 3 acres. The north half was twice disked parallel to the north line, the remainder being disked but once. The seed was then sown and covered with a harrow drawn parallel to the railway fence. The seed sown was a mixture of various remnants from other plats, as follows:

*Plat 76.*—*Agropyron tenerum*, *Chloris elegans*, *Bouteloua oligostachya*, *Sporobolus airoides*, *Elymus canadensis*, *Eriocoma cuspidata*, *Sporobolus cryptandrus*, *Agropyron occidentale*, and *Phaseolus rutilus*.

*Plat 77.*—*Andropogon saccharoides*, *Chloris elegans*, and *Bouteloua oligostachya*.

## AREA B.

This area extends directly east and west, contiguous to the south side of Area C. No seed whatever was sown here, it being intended to determine what effect scarifying the surface would have on the development of native vegetation. A fine-tooth harrow was drawn over the area in an east and west direction.

## AREA D.

This space is 200 feet in width and located between C and E. No seed was sown and no cultural operations performed. The object in laying out the ground in this way, with an uncultivated and unseeded strip between two cultivated and seeded ones, was to determine, should the seeded plats prove successful, whether the grasses sown would spread naturally over unseeded areas.

The cultural operations are vastly more simple than those usually employed in the grass investigations conducted by the Division. This is necessarily so because improvement of the range at the least possible expense is the desideratum here, and not the growing of the greatest amount possible per acre. The production of forage is so small here, at best, that one is obliged to measure his pasture by square miles rather than by acres, and the operations in range improvement must be on a correspondingly large scale. It has been deemed wise, therefore, to operate simply, but on comparatively large areas. The only implements used are disk harrows and fine-tooth harrows. Every possible combination of these has been used. In some cases the seed was sown directly on the mesa, with no previous preparation of the soil; in others, disking or harrowing preceded planting. In all cases the seed was covered by disking or harrowing, or by both combined. As far as possible all cultural operations extended lengthwise of the long strips, and therefore diagonally across the washes. The gangs of the disk harrow were set so as to ridge up the ground as much as possible. This method spreads the run-off of water over more land, and the ridged condition holds it to a greater extent than any other method would do.

A small grass garden has been started on the university grounds, in which nearly all of the varieties sown on the reservation have been planted in small quantities. Here moderate irrigation is practiced. One of the objects of this garden is to form a check upon the seeded plats on the reservation.

Owing to the diversity of climatic and soil conditions which obtain in southern Arizona, it has been thought wise to extend operations over a greater variety of territory than would be possible in the immediate vicinity of the University. Consequently a plan was inaugurated to cooperate in the matter of range improvement with farmers and ranchers who were located in favorable situations. Aside from the

work performed directly by your agent, experiments are being conducted at eight other stations in the southern part of the Territory. In all of these cases those interested are doing the work with seed distributed from the station. The names and addresses of the ranchers who are performing experiments according to this plan are as follows:

M. R. Wise, Calabasas.

C. H. Baylis, Oracle.

H. C. Hooker, Wilcox.

Mr. Prince, Tucson.

Ozro Haskin, Tucson.

F. O. Benedict, Tucson.

W. M. Marteny, Arivaca.

W. B. McCleary, Helvetia.

Operations on the ranch of Col. H. C. Hooker are a little more extensive than in other instances. Your agent made a trip to the ranch in the latter part of February for the purpose of starting the work. Six small plats, aggregating about an acre of land, were sown to eight species of forage plants.

#### PRECIPITATION RECORDS.

In connection with the range improvement experiments, five precipitation records are being taken, in order to determine to what extent local variation in this particular obtains. Observations thus far conducted point to some very interesting conclusions, but they have not yet been continued long enough to enable one to generalize. The gauges are located as follows: Four miles north of the University; range reserve tract; Mescal; McCleary's camp; and 4 or 5 miles above McCleary's camp, in the Santa Rita Mountains. The first two are being attended to by the writer, the third by Mr. J. Ribail, and the latter two by Mr. W. B. McCleary. These, together with the record kept on the university grounds, give six readings, which will throw some light on our investigations.

#### SUMMARY AND SUGGESTIONS.

1. It being evident that the present unproductive condition of the range is due in the greatest measure to overstocking, it is desirable that some form of control of our public lands be devised whereby this practice, inevitable under present conditions, will be discontinued. How this desirable end may be reached does not appear clear, but it is evident that laws for the proper control and preservation of the ranges are essential, not only to the stock-growing interests, but also to the general welfare of the region, that the rains may be better conserved and prevented from disfiguring the surface of the country to an extent absolutely beyond the conception of anyone who has not had experience with these easily eroded Southwestern soils. The matter is of as much importance to the irrigation farmer as to the stockman himself, for the gulying of river channels during recent years and the cutting

of deep gorges in every depression, thereby destroying the tillable soils, are directly traceable to the influence of close grazing.

2. Just control, based on a system of land rentals which properly recognizes the rights of all ranchers located on the public ranges, would, it is believed, meet with popular approval and beneficial results.

3. The perennial grasses have been completely destroyed on large portions of the range. With absolute rest these areas would probably be reseeded in time, but it is believed that much can be done to expedite the matter by collecting seeds of native perennial forage plants in regions where they still persist and sowing them in the more favored localities of the denuded range. As far as the experiments which have been conducted indicate, the blue grama (*Bouteloua oligostachya*) and the Australian saltbush (*Atriplex semibaccata*) are the most promising for this purpose. *Bromus polyanthus paniculatus*, wire bunch grass (*Agropyron spicatum*), slender wheat grass (*Agropyron tenerum*), and shad scale (*Atriplex canescens*) also appear to be of some value for this purpose. It is impossible, however, to make definite recommendations at this time.

4. It is very necessary to test the germination qualities of native seeds. The grass garden started on the University grounds has served a useful purpose in this respect. The fact that native seed do not germinate when planted does not indicate that the species may not be a valuable one for reseeding worn-out range pastures, for it often occurs that native seed for various reasons does not germinate well. It is suspected that some of the seed gathered last season was not mature. This fault is often unavoidable, either on account of the methods of fruiting of the plant or on account of the collector's lack of time to wait for maturity.

5. Experiments thus far conducted in reseeding the worn-out mesa pastures having been begun in the month of January, it is desirable that subsequent experiments be carried on during or just before the summer rains. July or November will probably prove to be the best months for planting in this locality.

6. Judging from the season of 1900, grass seed can be most advantageously collected in the month of October. Seed of the native salt bushes can be gathered at any time from October to January.

7. On account of the excessive erosion careful attention should be paid to all cultural operations, and implements should be drawn in such a way that the rainfall may be held and spread over as much land as possible. In other words, cultural operations which extend diagonally across the drainage will usually prove most beneficial.

8. Fifty-two acres of the fenced portion of the reservation are under cultivation. This area is divided into 60 plats, upon which have been sown about 40 species of forage plants.

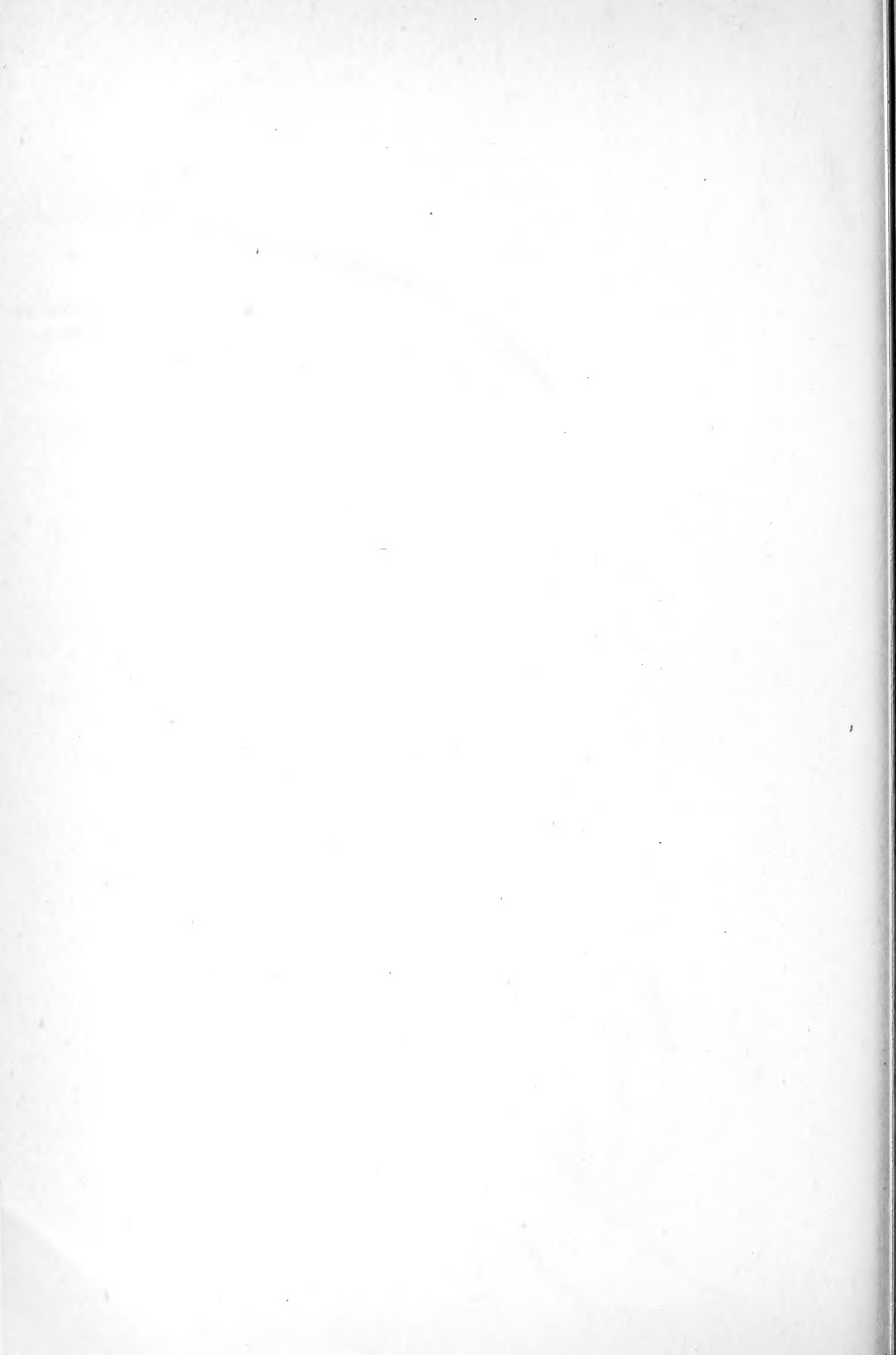



## BULLETINS OF THE BUREAU OF PLANT INDUSTRY.

The Bureau of Plant Industry, which was organized July 1, 1901, includes Vegetable Pathological and Physiological Investigations, Botanical Investigations and Experiments, Grass and Forage Plant Investigations, Pomological Investigations, and Gardens and Grounds, all of which were formerly independent divisions, and also Seed and Plant Introduction, The Arlington Experimental Farm, Tea Investigations and Experiments, and the Congressional Seed Distribution. Beginning with the date of the organization of the Bureau, the independent series of bulletins of each Division was discontinued and all are now published as one series of the Bureau.

The reader's attention is called to the following instructions for obtaining the publications of the Bureau:

"The serial, scientific, and technical publications of the United States Department of Agriculture are not for general distribution. All copies not required for official use are by law turned over to the Superintendent of Documents, who is empowered to sell them at cost. All applications for such publications should, therefore, be made to

"THE SUPERINTENDENT OF DOCUMENTS,  
"UNION BUILDING,  
"Washington, D. C."

The bulletins published in the Bureau series prior to this number are:

- No. 1. The Relation of Lime and Magnesia to Plant Growth, 1901.
- No. 2. Spermatogenesis and Fecundation of *Zamia*, 1901.
- No. 3. Macaroni Wheats, 1901.

