



R24

RATNER'S
Up-To-Date

METHOD OF DESIGNING
SCHOOL

OF

Designing, Cutting, Grading and Fitting

FOR

Ladies', Gentlemen's and Children's Garments

READY MADE AND ORDER MADE

ALSO DRESSMAKING AND FURS

CHICAGO, ILL.

WARNING

The entire contents both text and diagrams of Ratner's Up-To-Date Method of Designing are covered by copyright, and warning is given against infringement. Violations of our rights will be prosecuted to the full extent of the law.



COSMOPOLITAN PRINTING CO., 176 Blue Island Avenue
1908

STATEMENT OF SALES
Two Copies
MAR 20 1908
JAN 27 1908
CLASS A
197658





RATNER'S
THE TOP OF
DATE
TO

DESIGNING

PROF.
RATNER

COPYRIGHTED 1908

Ratner's Up-to-Date Method of Designing

A WORD TO ALL OUR FRIENDS.

Our patterns are absolutely correct both as to measurements and style. We have given years of study to the perfection of our method and we are assured that our claim of a "perfect fit for a perfect figure" is fully justified. If directions are carefully followed, failure or spoiling of material, is impossible. Each diagram contains explicit information as to how the pattern contained therein should be designed and cut. We use the simplest possible symbols in making and each new model is carefully studied before the directions are written. If the work of cutting and marking be done with careful attention to every printed sentence, success is assured. There can be no difficulty, for each

While our acquaintanceship has spread like fire throughout this vast country and edged its way among many of Cloak-makers, Ladies' Tailors and Dressmakers, it is but natural that we do not know all the Cloakmakers, Ladies' Tailors and Dressmakers or that all of them know us, and in order to satisfy the many inquiries we receive each day as regards our school, from the trimming men and all others who are seeking enlightenment or contemplate taking a course of instructions in this trade. We wish to say that our school has the best location and finest facilities for teaching students in the city of Chicago and New York, where we occupy a large space having large windows to the front, thus giving us the natural light, a great advantage over artificial light.

Every known convenience has been utilized for the convenience of our students. Aside from our office, which connects with the general office, is a private office for our clerical help. Ample wardrobe room is provided for our students, as well as large desk situated in the school for their own personal correspondence.

Our instruction room is divided into three distinct departments, viz: Department of Systematical Instructions, Department of Coats, Draping and Individuality.

Upon entering our school for instructions, the student receives his membership certificate, which also holds the receipt for tuition fees and the rules and regulations of our school. His first instructions are that of foundational principles, variation and measurements for coats. Before

piece of the pattern is fitted to the next with absolute exactness and care. Notches meet notches, Edges come together. Corresponding lines correspond. All it requires to do is to read carefully, intelligently and faithfully, to proceed step by step as directed. Not the novice alone, but each and every man who is about to use a pattern should read the instruction through with care. To ignore it is to put aside as valueless an important part of the pattern. No two diagrams are alike. Each and every one has its own characteristics. It is to make these clear and to simplify the labor of garment making that directions are printed.

advancing farther the student must stand preliminary examinations on the same, and if he averages up to the standard, he will then be given admittance to the grading department. There he will start with foundational principles, following with the variations and then continue with the variations and foundational principles. He will be thoroughly taught measurements and its applications. Here he must again stand preliminary examination on all points pertaining to skirts and positively cannot pass from this department unless he averages up to the standard in this respect.

Having passed through this examination, he will gain admittance to the Department of Individuality, Fitting and Draping. In this department Mr. Ratner assumes personal control at all times. Here we also have our tailor shop. In this department the student is fully informed as to all kinds of manipulations and exaggerations of patterns. The try-on here is thoroughly demonstrated having direct facilities in this respect. In the same department the student must stand his final examination, which consists of general principles on garment cutting, variations, manipulations and exaggerations, measurements and its application, as well as fitting and constructions, together with all the latest styles.

When he has demonstrated to us satisfactorily, that he is able to handle first class trade, he is given as an evidence of his proficiency a diploma, to emphasize our mark of approval of his capability.

INSTRUCTIONS SHOULD BE READ.

It is not safe for you to assume that you know all that we would say. You do not and you cannot. Only by reading each diagram can you do both us and yourself justice, and only by following the directions faithfully, can you obtain the best results. Following are a few directions, for further simplifying the work of cutting and designing. Attention to them is important. They are designed to help all those whose figures are individual or peculiar, as a great many of our patrons are apt to do, and they will undoubtedly prove helpful. Cloakmakers, Ladies' Tailors and Dressmakers assert that few, if any man fail of some slight differentiation from the standard. This being the case changes must be made; for all that we or any other pattern purveyors can do is to supply a perfect model for a perfect or standard figure and we have endeavored to make suggestions for such discrepancies as are most likely to occur. But clear and comprehensive as we believe these to be they are

valueless unless the individual diagram instruction first be read and studied. If we say "Lay the front below single large perforation straight lengthwise on material", and you put it on askew no after effect will bring about a well hanging skirt. If we say: "Fold on lines of perforations and stitch from each folded edge to form tucks," and you assume that lines are to be brought together, only misfortune can result. As it is not possible to adopt any formula that will meet the needs of all patterns, careful reading of the diagram is the first essential and intelligent carrying out of the directions is needful to bring about success. Each diagram contains its own special instructions together with each general one as apply to all patterns. With these careful reading and faithfully followed and following hints utilized every Ratner's pattern must and will give entire satisfaction.

INSTRUCTIONS FOR DIAGRAMS.

DIAGRAM 1. Draw a line which is called bust line. Get twice 36 large. Get $\frac{1}{2}$ inch backwards from 36. 1st allow $\frac{1}{2}$ in in front of 36 for which it will give us for canvas, linings & interlinings. Take your waist measurement on scale (A) get your 24 on the very same line as you started your 36.

divide the 24 into halves which is 12, run lines up and down. The $\frac{1}{2}$ in. you took off from the 1st 36, put the square to the bust line and the $\frac{1}{2}$ in. and run a line down. Measure this line 8 $\frac{1}{2}$ in. and that is our under arm measure. Put this square straight to the under arm measure and

Ratner's Up-to-Date Method of Designing

measure 8½ and draw a line forward. Correspond the top 24 and the 12 and also the end of 36 all the way down to waist line. Take 7 in. on square on top of bust line where it measures 12 and draw a line up till it measures 7. On the very same line just made, take 36 from bust line up, using scale B. On the underarm line draw a line up and measure 9 in. that is called strap measure. From the 36 in the front take 12 on scale A that giving us our neck. From this 12 to the 24 in the back divide into halves take ½ in. off from front yet. Draw a line from this ½ in. to the 9, run ½ in. down the bust line, and draw a line from this ½ in. to the 24 below the bust line. From the 12 you have in the front measure 36 large up. From this 36 to the 36 that you have on the 7 line, draw a line that it should measure ¼ of the bust line and 1¼ in. extra. From this line just drawn put the square straight to the neck measurement point so that your square should rest on the ½ in. that you have allowed in the front measure. The way your square lays, measure your neck in front and 1 in. down. Bring down the square to the neck measure and measure the front length. Now correspond the front length to the underarm length and draw a line forward.

In Back—Take 1 in. backward from the beginning 36, rest your square on this inch, 36 and on your 7 or any dept. of eye measurement. See that these 3 points correspond. Now draw a line all around, leave the square lay and measure your neck measure. From the neck measure draw a small line ½ inch up. Put the square with N to rest on center and to this ½ inch shape it. The line which crosses the 24, take ½ inch below and put the square with J to this ½ inch and rest on ½ inch from neck and that will shape your shoulder. Measure the front shoulder from the point neck about the same amount and ¼ inch less yet.

Arm Eye—Put the square to the bust line, and to 24 and to J and draw a line all around.

Front Part—Put the square to the ½ inch below the bust line, and let it rest on the center line from 24 to 12. Shape until L keeping your pencil on the same point and bring your C up from the curve, then let your square rest on the shoulder measure. That finishes our box all complete and now we could make any garment we need in it, with the exception of diagrams 3, 4 and 5.

Shaping—Take 2 inch from shoulder in arm hole in back, and take 1 inch from the line you have in the back, put B, on point in back that you have got the 2 inch and let it rest to the 1 inch in the back and draw a line. Put H on the Bust line and on the shaping line and let it rest on your working line. Put 1 inch from square on working line and measure 24 small. Put your C from square to your working line and let the square rest itself on top. Take 1 on the square and let the square on top rest on the line you just made. Take 1 inch on square put on your C line and measure again 24 small. Put your M on the 24 and let it rest to your underarm line, take 1 inch in front put your L on square and let it rest to your underarm line on top and draw lines. From this L take 24G, use scale C make a mark. Let ½ inch out in the front from the square and get small 24 from this 24 to G divide into halves, and get ½ inch on each side. Draw a straight line from the 24 by resting the square in point of neck not any higher than to bust line and also the very same thing to the next line from the last ½ inch. Now measure from point neck to bust line, ¼ of your bust plus 2 inch that will give you the height of the bust. Draw a line crossways, now put the square with I to the ½ inch and let it rest on crossline point. Draw a line from I to 6 and then move the square down and let M rest on crossline and shape it. Second dard alike.

For Hips—Let your square rest with top to waist line and draw a line down from last inch. Draw all your working lines down. Measure from front waist line 6 and 12 and

correspond with your back lines. If in the back waist line is taken out 1 inch so take ¾ inch on the hip line. When the back is an inch in waist line the width, so take 1½ inch on hip line, always ½ inch more than the top.

For side body—Take ¾ in. on hip outside the line and 1 inch on the 12 line, correspond the ¾ with the inch by drawing a straight line, shape it with letter H to waist line. For the same side body take ¼ inch in the line on hip line and correspond all the way down a straight line, shape it by letter I corresponding to waist line.

2nd side body—Take 1 in. on each side outside the line and 1¼ inch on each side of the 12 inch. Draw straight lines and shape it by letters K & J as diagram shows.

Front—Measure as much as you have in the waist line and ¼ inch more on the hip line. Draw a straight line.

Dard—Draw a straight line from the last ½ inch all-way down, measure on waist line and always ½ inch more on hip line. Draw a straight line. Put the square ¼ inch in line of G, and draw a straight line from 6 to 12, shape it by putting letter L to G. Measure your hip back and front till you get your right measurement, as much as on 6, always ½ inch more on 12, shape it by putting letter F. For front allow 1½ inch on bust line, 1 inch in waist line, and 1½ inch on hip line, shaping according your diagram this being for tight fitting and not for fly front. If for fly front so take 1½ in. and draw straight line. (Shape and collar). Get ½ inch on each side of point neck, the forward ½ is for the lay off line. Draw a line any length of your shape wanted by resting on the forward ½ inch. Rest the square to this line and to the inch below the 12, shape your shape any way you prefer.

Collar—Rest your square to the point of shape and the ½ inch in point of neck. Shape it accordingly.

DIAGRAM 2—Box same as first one. Take 1 inch for the width of back in waist line and divide into halves. Divide your shoulder into halves, rest your square to the half shoulder and to the ½ inch in the back. Draw a line to bust line only, rest your square with letter C on working line, correspond it to to the line you drew from the half shoulder. Put your square with letter I to the inch on the back and rest it on the same line as C. Side bodies same as first diagram.

Front—Get 1½ inch from the underarm line and shape it with letter L by resting it to the underarm on top. Take 24G on the 1½, plus 1 inch using scale C. Take 24 small from the front line, rest your square to this 24 and 1 inch back from point of neck, draw a line to bust line only. Get your height of the bust and draw a crossline. Rest letter I to the 24G line and correspond it to your cross line height of bust, by shaping it with letter M. Divide your shoulder into half, put your C letter on the half and let your square rest to M. Shape, front, collar and hips as first diagram.

DIAGRAM 3, 4 and 5. Divide the shoulder into as many spaces as seams needed. In box from diagram 3, take in waist line ¾ inch out. For back 1 inch in width. Get ½ inch from this inch. Take 1½ inch on square and put on this ½ inch and get 24 small. All pieces alike. Take 1 inch on square and put on front part, then get 24 small. The rest the same as the first diagram, with the exception of ½ inch on each side, instead of ¾ inch which was allowed, shape it accordingly. Diagram 4 and 5, take ½ inch out in the back, 1 inch for the width of back in the fourth and ¾ for the width of back in the fifth. The outs the same as in third. For fourth take 2 inch on ½ inch and get your 24 and the rest all alike. For fifth take 2¼ in. on ½ inch and get your 24 and the rest all like.

Hips—3, 4 and 5 alike. The width of back's should always be ½ in. wider than in the waist line. The sides, rest

Ratner's Up-to-Date Method of Designing

the square to the 1 inch all the time, and draw a line from 6 to 12 with a trifle wider than shape with letters H and I, left to right and right to left. Shape and collar alike.

Diagram 6. Until waist same thing as 2nd Coat. For ripple take 41 small from waist line plus 1 inch to 41 length. Get 12 from the 41 up and use as a pivot. Put your pencil about 1/2 inch above waist line and the finger on 12 inch, sweep it backward that it should strike the dart point. On 41 and 1 inch sweep the same. Measure in waist as your 3 parts measure, and on hip line as much as hip measures. Allow for pleats. For front take 1/2 inch off from waist line and allow 1/2 on bust line, draw a line from 1 1/2 to 1/2 in. all way down, shape according to diagram.

Diagram 7. Until waist same as 2nd coat. Below waist 3 inches. Divide accordingly, it should measure 7 inches less than the full hip or 3 1/2 less than 1/2 of the hip. (For skirt.) Rest your square to the 3 inch in the front straight with the front line. Get twice 40 large, the 2nd 40 divide into half and rest your square on the line 40 where you have the half and run a line up. Measure 40 small plus 1 1/2 inches. Draw a line from the 3 inch in front to this 1 1/2 inch, shape according to diagram. Front same as diagram 6.

Diagram 8. Box same thing as 1st coat. Get 2 in. out of back and use 24 large. At your 24 on the bust line get 1 1/4 in. up, put your letter K, by resting the square on 24 that you made in waist line. Put H on bust line and rest on working line, finish side body as usual. Take 1 1/2 in. in front and shape with letter L. Take 3 1/4 in. off from waist line, rest the square at 1 1/2 in. in bust and to the 3 1/4 draw a line. Shape hips according. Shape and collar alike.

Diagram 9. Box same as 1st. In this diagram we have a Cape. Change 1st. Take 1 1/4 in. from the underarm line and run a line all way down. Place the square with L and M to the 24 and to the front line and rest it on top to the 1 1/4 in. marker for a dart, run the dart into pocket, that finishing on the 1 1/4 in. side, get 1 1/2 in. on each side and shape. At front take off 1 1/2 in. from waist line. Place the square at point of bust and run a line up and down all the way to shoulder. From this line take as much as you want and take so much from the top of the neck, at the same with the exception of the dart at top. Now the dart is at the side. Take about 12 1/2 in. from bust line, and 3 1/2 in. from working line in side. Take about 1 1/4 in. from the underarm seam on front. Draw a line from 1 1/4 to the 12 1/2, corresponding with the 3 1/2. Take out 1/4 in. on each side of line on waist line, also 1/4 in. on each side on bust line. As much as was taken out of bust line allow on 1 1/2. Finish front and collar alike.

Diagram 10. Box same as 1st. Divide shoulders into 1 1/2 in. measure the back 1/2 in. wider than the side. The width of back in waist line should be 2 in. From this 2 in. take 1 in. and shape with C and I. Take 2 in. on square, place on C and get 24 large; shape with M resting of top of underarm line. Take 1 in. out for front, place 24 G on waist line, plus 2 in. for a dart. In front get 24 small and 1 in. and shape according. Collar and shape alike.

Diagram 11. Prince Albert. 2 in. below waist. Work the same as diagram 7, with the exception of measuring 6 in. smaller, the hip instead of 7 and 4 1/2 instead of 3 1/2 in. Commence skirt same as diagram 7 with the exception of not allowing 1 in. on top for shaping. Measure 60 in. in length, draw a working line in back. Measure from 60 in. outside the working line, 40 small, correspond with large 40. Divide top of skirt in 3 parts, take out 2 darts according to hip measure. For front take out 1/2 in. in waist line, correspond with point of bust line. For allowance take 2 in. waist line and 3 in. bust line. Shape accordingly.

Diagram 12. Prince Albert. Work to waist as second coat. For skirt measure on front 41 small, and deposit your

square to this line and to the 41 small, run a line up and sweep twice 41 large. At the first 41 put your square on 41 in. and to the 41, draw a line up, measure small 41 plus 2 1/2 in. Put your square in the point of the waist line in front and to the 2 1/2 in. line, and draw a line. Measure this line and 1/2 of the first plus 5 in. for darts. Divide this into 4 equal spaces. Shape front as diagram 11.

Diagram 13. Reglan's Coat. Make second coat all complete. Take about 1 in. in center of back above bust line and use as a pivot. Place finger on pivot point and pencil on arm hole about 2 in. above bust line and sweep it to come in point neck. For front take about 2 in. above bust, and use as a pivot. Put pencil on letter L, and sweep it to come in point neck.

Diagram 14. Box same as 1st. Take in waist line about 1 in. for back and 1 1/4 in. for front; draw straight lines from top of underarm to these points. Take square and place to the front shoulder and about 3 1/2 in. below bust line in center back, run a line from shoulder about 5 in. and measure 30 small, then shape it, which finishes the front cape. For the back, place the square again to the shoulder and rest it about 1 1/4 in. in front below bust; draw a line, measure 30 small, and finish the back. C. Parless.

Diagram 15. Loose, Long and Circular. Follow directions according to other directions and shape it according to the diagram.

Diagram 16. A Coat with sleeves all in one piece. Make as 2nd coat, all complete, then work the shoulders as diagram 14. Finish the sleeves with your own idea.

Diagram 17. Make first diagram front and second diagram back. For Cape. From the 12 draw a line 1 in. down. Draw line from this line forward and measure from the 12-30 large and 10 small, deposit the square at 30 small and straight with the line, draw a line all the way down. Measure 18 in. in length, deposit the square at 18 in., draw a line backward and forward, take off 1 in. or 1 1/4 in. in front for the cape. Measure 30 in. or 30 large on the 18 in. line, commencing from the neck. Correspond the 1st 30 in the back with the 30 small on the 18 in. line. Shape from shoulder to this 30. Round the back shoulder a trifle, measure the back as much as wanted and correspond with the cape plus 1 1/2 in. for fullness.

Diagram 18. Single and Double Breasted Vest. Make front as diagram 1, with the exception of allowing the allowance, this judging yourself. The back a regular Prince Chap look with a dart in the middle.

Diagram 19. Make the second coat all complete and any length you prefer. Round the front piece and round the front side piece on the dart around the waist line. Measure as much as needed for hip.

Diagram 20. Box same as 1st. Shaping in back and underarm as Prince Chap No. 2. In front allow 2 in. longer and then that will give us the fullness for the blouse. For a shirt waist all w 3 in. longer.

Diagram 21. Sleeveless Shirt Waist, Russian Blouse or Eton. Shape by judgment.

Diagram 22. Make back and sides same as loose coat, front as first coat. Any length you desire.

Diagram 23. Tight-fitting Wrapper. Back and sides same as Vests. Front as first coat. Shape according to diagram. If for gathering, allow 5 in. in front. Shape for yoke.

Diagram 24. Make the back of first coat, front of second coat, work by measurement 40. Two underarm pieces divided to your desire.

Diagram 25. Plain tight fitting Sleeve. Draw a straight line up and down. Get 30 small, divide in half and 1 1/2 in. higher. The way the square rests get 14 in. from 14 in. get 10. From 10 take 2 in. up, draw lines from 1/2 in. lower 30.

Ratner's Up-to-Date Method of Designing

14 and 10 backwards. On the $\frac{1}{2}$ in. rest the square, measure 36 large and 3 in. On 36 small take $2\frac{1}{2}$ in. and divide in half. Draw a line from the center $2\frac{1}{2}$ to 3 inches and get center. On the 14 take $1\frac{1}{2}$ in. for top sleeve, 2 in. for under sleeve, and from this 2 in. get 36 small 1 in. and from this inch $1\frac{1}{2}$ in. for top sleeve. On the 10 in. line get $6\frac{1}{2}$ in. Shape accordingly.

Diagram 26. The same kind of sleeve with the exception of allowing 36 small by the 3 inches on top line. Shape according to diagram. The straight lines are for pleats if you want them.

Diagram 27. Same as 25. All complete except to divide the center on top sleeve and measure 6 inches or else as much as your shoulder measures on a regular coat.

Diagram 28. Top same as 26 except strap drawn from head and darts allowed. In elbow get $2\frac{1}{2}$ in. for top sleeve, 2 in. for under sleeve, 36 small also for under sleeve from this 36, $2\frac{1}{2}$ in. Shape according to diagram.

Diagram 29. Shirt Waist Sleeve. Draw a line, get 36 small, 14, 10, and 3 and 2 in. up from the 10. On 36 draw a line backwards, get $\frac{1}{2}$ of the arm side and $\frac{1}{2}$ in. back. Draw a line from this $\frac{1}{2}$ in. to the point of 36 small, get center of this line for pivot. Shape according to diagram.

Diagram 30. Plain Sleeve without an under sleeve. From 36 large and 3 in. run down a line to correspond with the line 36 small in front. Get 36 small for under sleeve. Shape to diagram.

Diagram 31. Leg of Mutton. Draw a line, get 18 in. in length, divide into half. On top of 18 in. draw a line higher, take 1 in. below for pivot. On this 18 in. take 36 large and 2 in., get $\frac{1}{2}$ in. back from the 2 in. and sweep from the pivot. Draw a line from the $\frac{1}{2}$ in. to the pivot point. Shape it accordingly.

Diagram 32. Work same as 31 and by the 18 in. line take 3 in. instead of 2 in. Divide this line in half and draw a line up. Measure 36 and 1 in. down. Shape to diagram.

Diagram 33. Top same as 29. Bottom take 12 in. in length, from the 12 take 2 in. up and shape according to diagram.

Diagram 34. Take 36 small, 2 in. up and from this 36 take 14 in., 3, 10, and 2 up. From the lower 36 draw a line. Take 1-36 large and 1-36 small. One inch back draw a line to the 2 in., get center from this line and draw a long line by placing the square to this line, which will give the pivot. Shape according to the diagram.

Diagram 35. Sheering. Top same as 34 except 3 in. larger and length as much as you want for sheering. Shape to diagram.

Diagram 36. Angel Sleeve. Draw a line in center of paper up and down. Take $\frac{1}{3}$ of arm eye, from this third draw a line backward and forward. Take on each side $\frac{1}{2}$ arms eye and 1 in. up, draw lines according to your diagram.

Diagram 37. Children's Coat. Draw a line, get twice bust measure size plus 2 in. In the back take waist measure and then from this waist measure to the 2nd bust measure; divide into half. Shape accordingly.

Diagram 38. Children's Sleeve. Draw a line and go by small measurement as diagram shows. Shape accordingly.

Diagram 39. Children's Leg of Mutton Sleeve. Go by same small measurement. Shape accordingly.

Diagram 40. Children's Bishop. Go by small measurement as picture shows. Shape accordingly.

Diagram 41. Cape. Draw line in a square. Get the neck measure on both sides, draw a straight line from one to an-

other. Measure again neck measure. This last measurement is our pivot for sweeping the flare and the neck.

Diagram 42. Make a regular cape and shape a sailor collar as in diagram.

Diagram 43. Regular Cape. Shape for Collarette according to diagram.

Diagram 44. Regular Cape. Shape for fancy sailor collar, accordingly.

Diagram 45. Opera Cape. Shape according to diagram and extra cape for colliarette.

Diagram 46. Collars and Storm Collars.

Diagram 47. Seven Gore Skirt with Flare. Draw a line, measure 6 and 12 in. down, from the 6 measure the hips on scale 20 to 54. Measure this way 4 times. At 12 in. the first box measure $\frac{1}{2}$ in. more than hip measure, 2nd $\frac{3}{4}$ in. more, 3rd 1 in., and the 4th $1\frac{1}{4}$ in., that means more than the small hip measure. Back pleats allow according to your judgment. In front take off 1 in. and shape the waist. It could be made any skirt by not cutting a new pattern. For large stomach or for a woman in a family way allow 1 in. higher in front and 1 in. lower in back. Shape accordingly.

Diagram 48. Very same box only divided in a 9 gore with side pleats. Shape according to diagram.

Diagram 49. Circular Skirt. Draw a line, measure 6 and 12 in., take 41 small from the 6, pivot at the beginning of the line, commencing at 6 and sweeping backward. The same from 41 and 12, measure waist, hip and also all the lengths if you prefer with pleats or without pleats. Shape according to diagram.

Diagram 50. Very same as 49 only shaped into a yoke, and could be made as many points as preferred.

Diagram 51. Regular 9 Gore Skirt shaped into a Princess effect. Shape according to diagram.

Diagram 52. Princess Robe. Make a regular box, divide the back into 3 pieces by dividing $\frac{1}{4}$ of the waist, divide the front into 4 pieces also by $\frac{1}{4}$ of the waist line. The hip, take $\frac{1}{4}$ of the hip measure and divide into 3 parts. The front hip, take $\frac{1}{4}$ of the hip measure divide into 4 parts. Shape accordingly.

Diagram 53. Make a plain skirt box. Follow instructions on diagram.

Diagram 54. Make a skirt box and follow instructions on diagram.

Diagram 55. Pair of pants and riding breeches; follow instructions on diagram.

Diagram 56. Front of side saddle riding habit. Follow the instructions by the measuring out with the large square with $\frac{1}{4}$ of the regular size.

Diagram 57. The back of a side saddle riding habit. Follow the instructions as given in 56, also leggins.

Diagram 58. Collars, cuffs, girdles, collarettes. Shape to diagram.

Diagram 59. Back measurement.

Diagram 60. Front and sleeve measurement.

How to measure with the small square.—Always figure the small square $\frac{1}{4}$ of the large square. For instance, if 36 measures 9 inches on large square, on small square it will measure 36 $2\frac{1}{4}$ inches.

Ratner's Up-to-Date Method of Designing

How to get sizes from 30--48.

Take bust measure and divide it into 3 parts $\frac{1}{3}$ of bust is called "Neck Measure" $\frac{2}{3}$ of bust measure is called "Waist Measure." Plus 5 inch to bust measure, is hip measure.

How to get depths of Scye underarm and strap measure:

For an example size 36.

Bust measure divided into 3 parts $\frac{1}{3}$ of bust measure is neck measure 12.

$\frac{2}{3}$ of bust measure is waist measure 24.

Plus 5 inch to bust measure is hip measure 41.

How to get underarm depth of Scye and Strap.

See divided measurement.

To get small bust measure.

Take neck measure from bust measure in point of front bust.

USE SCALE A OR B.

Bust	Waist	Neck	Hip	Underarm	Depth of Scye	Strap	Small Bust
30	20	10	30.5	8	6 $\frac{1}{2}$	8 $\frac{1}{2}$	10
32	21	11	32.5	8	6 $\frac{1}{2}$	8 $\frac{1}{2}$	11
34	23	11 $\frac{1}{2}$	34.5	8 $\frac{1}{4}$	6 $\frac{3}{4}$	8 $\frac{3}{4}$	11 $\frac{1}{4}$
36	24	12	36.5	8 $\frac{1}{2}$	7	9	12
38	25	12 $\frac{1}{2}$	38.5	8 $\frac{3}{4}$	7 $\frac{3}{8}$	9 $\frac{1}{2}$	13
40	26	13 $\frac{1}{2}$	40.5	8 $\frac{3}{4}$	7 $\frac{3}{8}$	10	13 $\frac{1}{2}$
42	27	14	42.5	8	7	10 $\frac{1}{2}$	14
44	28	15	44.5	7 $\frac{1}{2}$	7	10 $\frac{7}{8}$	14 $\frac{1}{2}$
46	30	16	46.5	8	7	11 $\frac{1}{4}$	15 $\frac{1}{2}$
48	31	17	48.5	7	7	12	16

Measures for Skirts.

Waist	22	24	25	26	26	27	29	30	32	34	36	38
Hip	39	41	43	45	45	48	50	52	56	56	59	61
Front	40	41	41	45	42	42	41	41	40	40	40	40
Side	43	43	43	43	44	44	43	43	42	42	42	42
Back	43	43	43	43	44	44	43	46	42	42	42	42

Measures for Children.

Weight	15 lb.	22	29 $\frac{1}{2}$	37 $\frac{1}{2}$	42	45	55	70	89	100
Year	$\frac{1}{2}$ year	1	2	4	6	8	10	12	13	16
Height	1-6 inch	1.8 $\frac{1}{2}$	1.8 $\frac{1}{2}$	2	2.6 $\frac{1}{2}$	2.9	3.1	3.4	3.6 $\frac{1}{2}$	4.8
Bust	18 inch	19	20	22	26	27	29	30	33	34
Waist	18 inch	19	20	21	23 $\frac{1}{2}$	23	24	23	23 $\frac{1}{2}$	23 $\frac{1}{2}$

Measures for Ladies Pants.

1 waist to chair 10 inches, 2 chair to bottom 30 inches, that gives the inside lengths Waist 24, hip 41, knee 19, bottom 15.

For breeches take from waist to chair 10 inches and from waist to knee 26 inches and knee to calf 10 inches including opening, Waist 24, hip 41

For riding habit on the saddle take measures from waist to knee & knee to heel of shoe waist and Hip as above.

TICKET MEASUREMENT.

Date

Name

Street

Town State

Coat Skirt

Suit Price

Deposit Balance

Lining Color

Trimmings

Order

Goods

Plate

Coat

Dept of scye Length of Waist

Length of Coat No.

Width of Back

Strap

Under Arm

Bust

Waist

Hip

Front

Neck

Sleeve Inside Seam

First Fitting

Second Fitting

To be Ready

Tailor

Remarks

Skirt

No.

Goods

Plate

Waist

Hip

Front

Size

Back

Remarks

Measurement.

For diagram 59-60. Diagram Number 59.

All heavy lines on diagrams are measures:

1 depth of scye, 2 Length of back to waist 3 all length, 4 width of back.

Diagram Number 60.

1 Strap from neck bone to arms eye. 2 underarm, 3 bust, 4 waist, 5 hip, 6 front length from neck to waist 7 neck.

SLEEVE:

Sleeve on diagram 59, 1 shoulder to Elbow. Elbow to wrists. For tight fitting take muscle elbow and wrist.

Ratner's Up-to-Date Method of Designing

HOW TO ADJUST SKIRTS TO STOUT FIGURES.

The stout woman, given to embonpoint, is far too often the victim of ill-fitting skirts which accentuate in place of reducing apparent size. Cloak-makers, Ladies' Tailors and Dressmakers seldom understand just how the difficulty can be overcome yet the symmetry of the pattern preserved. The proper method is to secure a pattern of the correct hip measurement, to cut carefully and to stitch all seams with precision, then to fit the skirt to the figure. To do this it must be pinned smoothly and snugly round the hips, with the front gore allowed to drop down until it hangs perfectly straight, and the fulness laid in plaits at the back and pinned into place. To retain this essential position of the front gore those at sides and back must be raised as far as necessary. When the front gore hangs satisfactorily and the skirt is smooth over the hips the inverted plaits, or back edges, must be carefully brought together so that they meet exactly in the centre. The crosses and perforations indicate the size of plaits required for the perfect figure. As the stout woman is apt to be somewhat out of the prescribed line the plaits must be

adjusted to her needs. When properly finished their edges should meet and fall in straight lines. As soon as the plaits are adjusted to give that result they must be pinned firmly into place and the fitting of the hip darts or seams undertaken. When the skirt is fitted with darts they should be pinned up, at the indicated points, to exactly fit the hips, then stitched and pressed flat. When no darts are used the seams must be adjusted from the hips up, either taken in or let out as required, until perfect smoothness is the result. When that is done the skirt must be carefully stitched and pressed, then again put on the figure and pinned to the belt, when the lower edge can be trimmed off as required and finished.

FOR SLENDER FIGURES.

Slender figures require different treatment. As a rule, there is no need to drop the front; but the hips should be fitted exactly as are those of the stout woman, the plaits at back adjusted with the same care and the belt attached before the lower edge is touched.

HOW TO MAKE CHANGES CORRECTLY.

Anyone whose measurements are correct by the recognized standard can use our patterns without alterations; but there are many figures that are over broad for the height, over long of waist, or over short from waist down; whose arms are longer or shorter than the standard requires. For all such some changes must be made.

Too often the Cloak-makers, Ladies' Tailors and Dressmakers simply cut off or adds to length at the lower edge. To do either is to mar the symmetry of the pattern and to destroy the effect. The proper method is to add to, or take from, midway of the length of the portion, whatever it may be.

If the skirt be too long, lay a tuck in each gore just above the knees before laying the pattern on the cloth.

If it be too short, cut each gore in two at the same point and insert as wide a piece as required, then lay the pattern on the material as directed.

If the waist be too long, lay a tuck as wide as necessary in each portion midway between the arm's eye and the lower edge. If it be too short, insert a piece of the necessary width at the same line.

If the sleeve be too long, measure the arm to ascertain how much, then lay one tuck midway between the elbow and the wrist edge, one midway between the elbow and the upper edge, each taking up half the extra length. If a two-piece sleeve, lay tucks in each portion. If the sleeve be too short, insert strips of necessary width at the same points. By this method the outline is preserved while the desired length is easily obtained.

HOW TO INSURE A SATISFACTORY SKIRT.

Every skirt should be joined to the belt before being finished at the lower edge. No error is more common than reversing this last procedure and none more unfortunate. Every human figure has its peculiarities. It seldom happens that the two sides are exactly alike. Again circular portions sag. It is not possible to make a skirt hang with perfect evenness by merely measuring it before attaching to the belt. It must look even when worn, whatever the sides measure, and such result can be obtained only by following this rule.

Short skirts for the street happily have become general, but to secure anything like a graceful effect they must be perfectly even. Nothing could be more fatal to their success than an irregular or dropping outline at the lower edge. To get the best results it is necessary to stitch all the seams, press the plaits if there are any, to adjust the skirt over the hips as required and to join it to the belt,

previous to finishing the lower edge. The skirt should then be placed upon the wearer and measured from the floor up by means of a wooden rule, these measurements being taken at intervals of a few inches for its entire width. If the length is desired to be two inches from the floor the skirt should be marked with chalk at exactly that distance as indicated by the ruler, and these markings should be taken with exactness. The skirt can then be turned up and basted with absolutely certainty of evenness and the hem or facing stitched. If the skirt is to be shorter or longer it is necessary only to mark at the given point, but two inches is the accepted length for the season and the one most generally liked. If it is a bit difficult to measure from the floor an easier way can be found by allowing the wearer to stand upon a table when it becomes quite simple to measure from the table up and to make the requisite markings.



Ratner's Up-To-Date Method of Designing

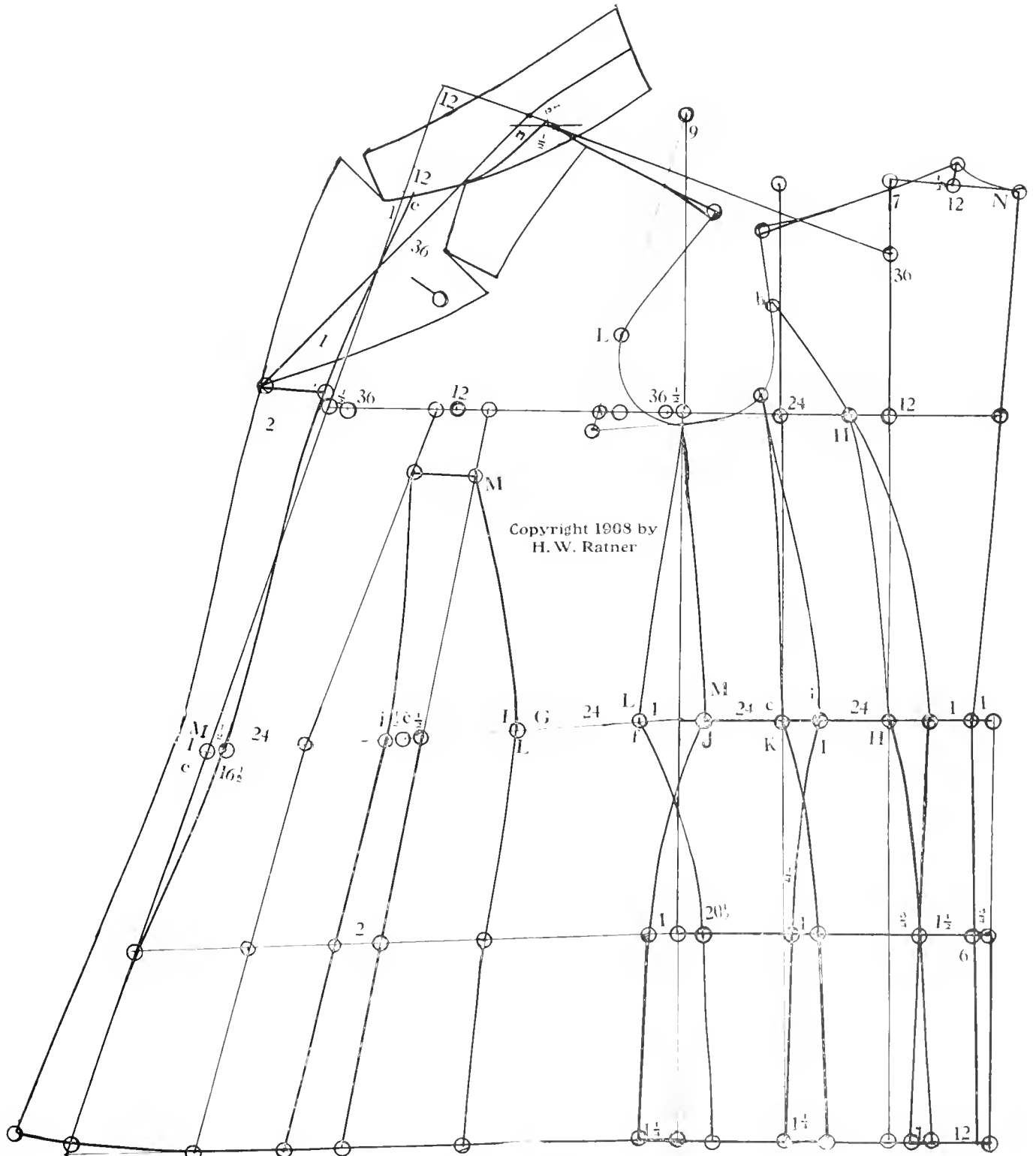

Diagram No. 1.

Ratner's Up-To-Date Method of Designing

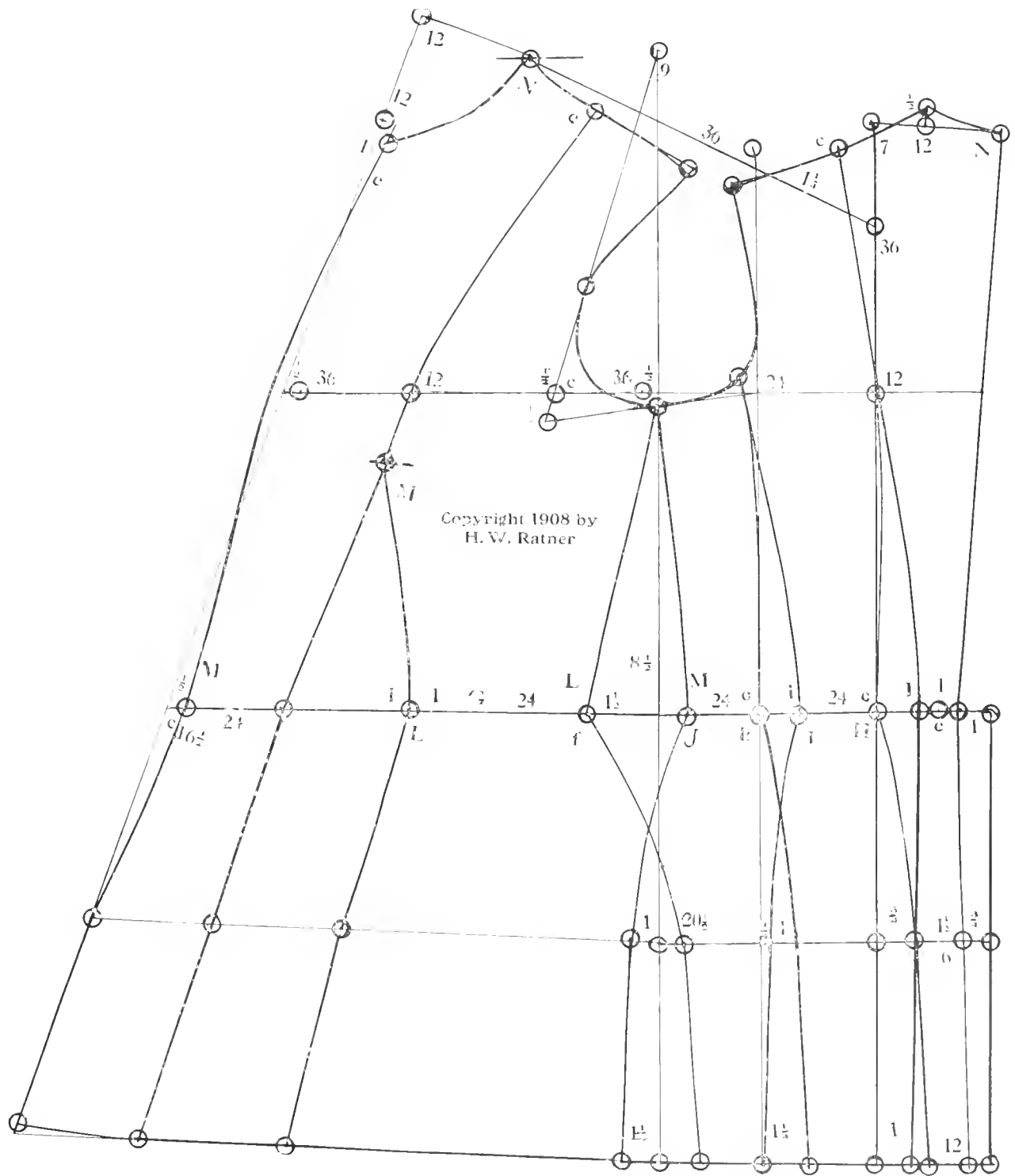

Diagram No. 2.

Ratner's Up-to-Date Method of Designing

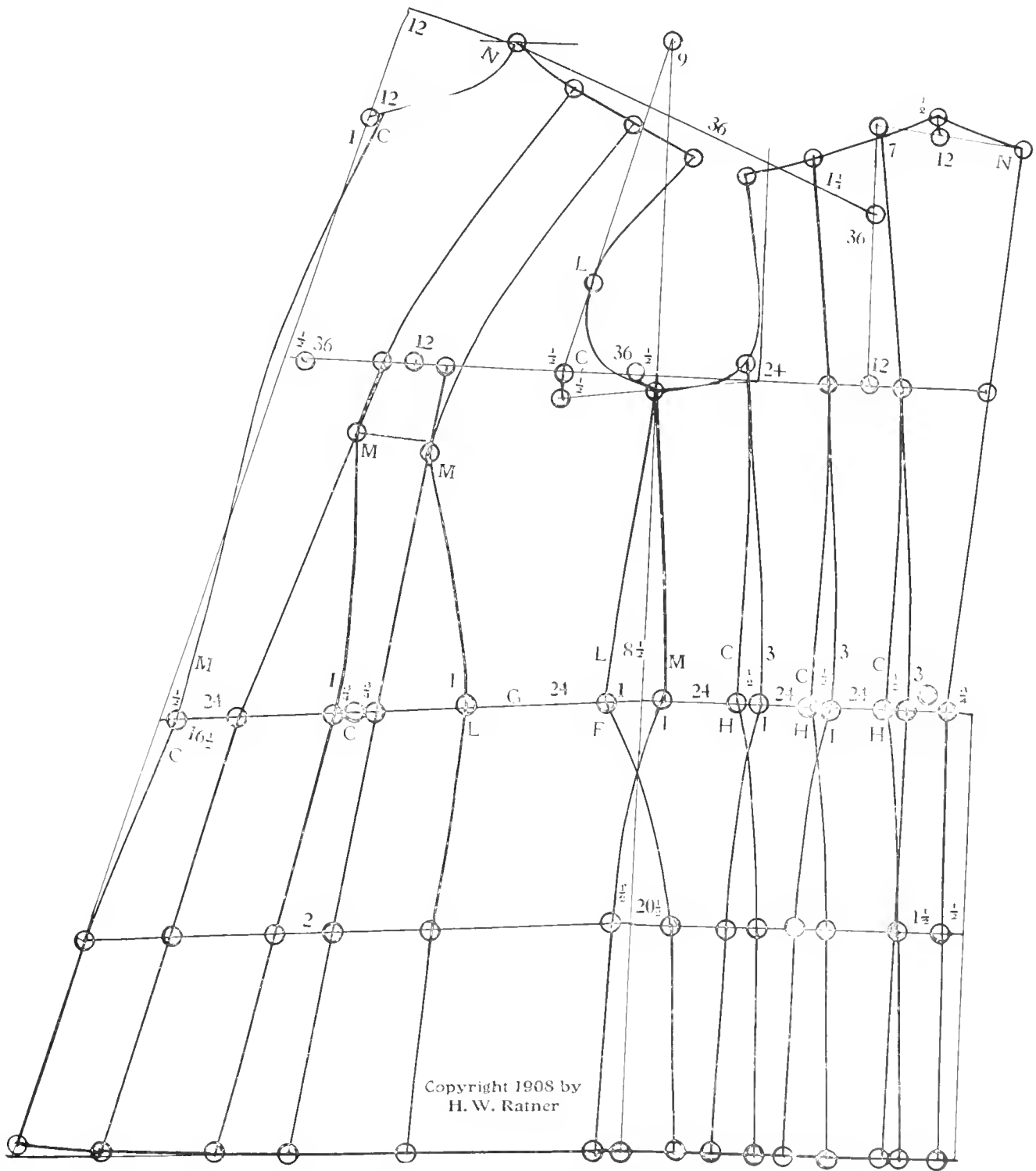

Diagram No. 3.

Ratner's Up-To-Date Method of Designing

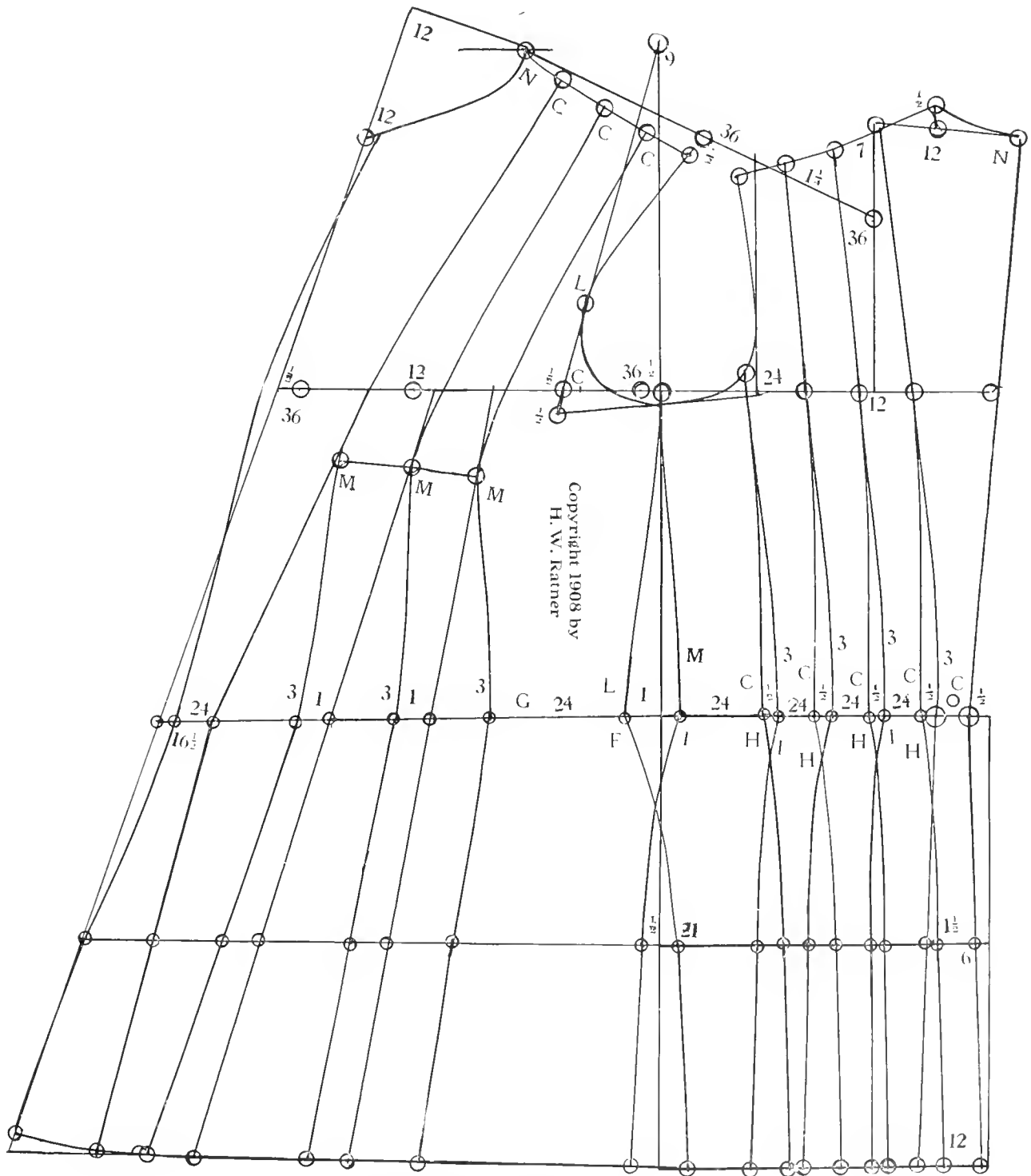

Diagram No. 4.

Ratner's Up-to-Date Method of Designing

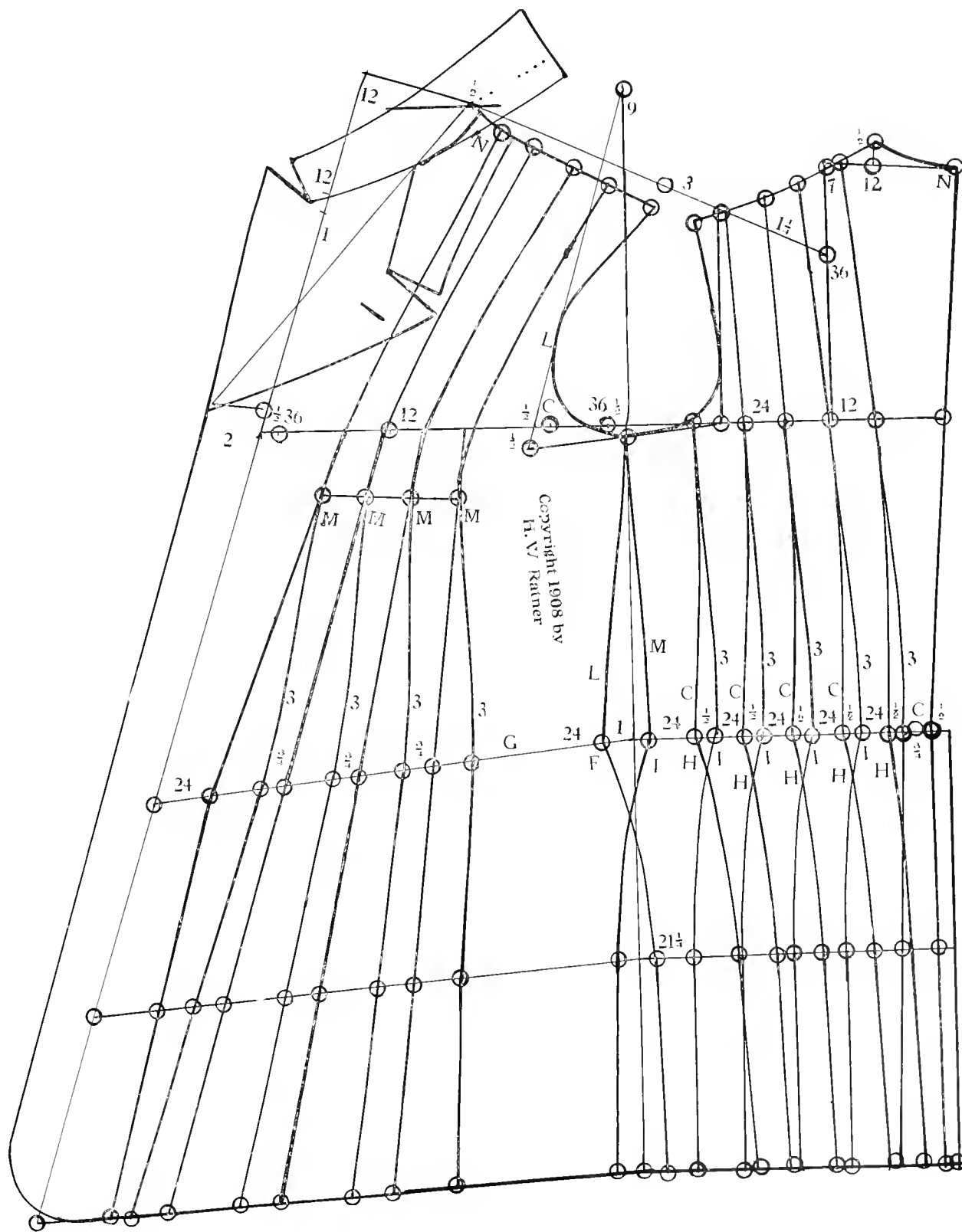

Diagram No. 5.

Ratner's Up-To-Date Method of Designing

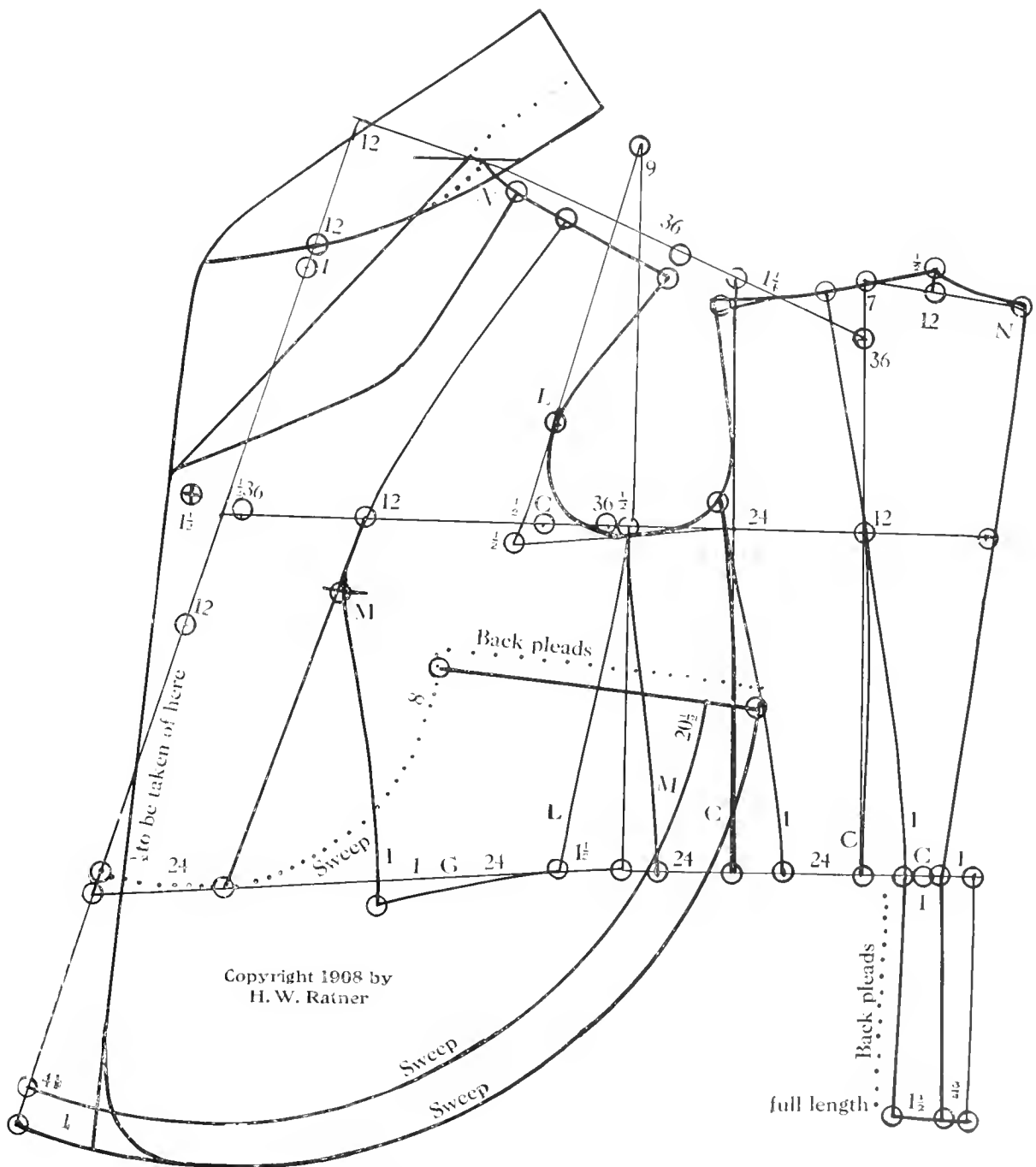

Diagram No. 6.

Ratner's Up-to-Date Method of Designing

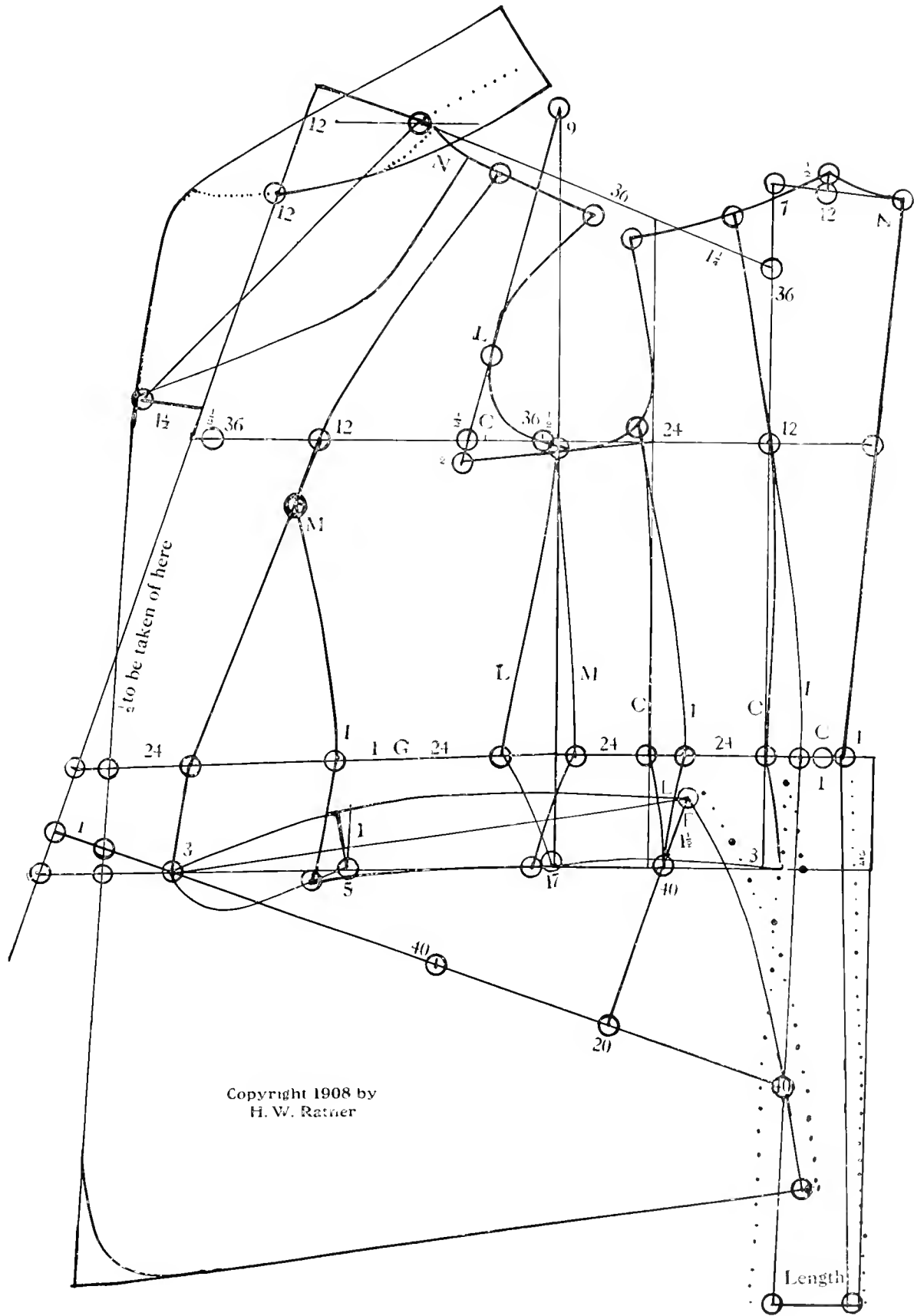

Diagram No. 7.

Ratner's Up-to-Date Method of Designing

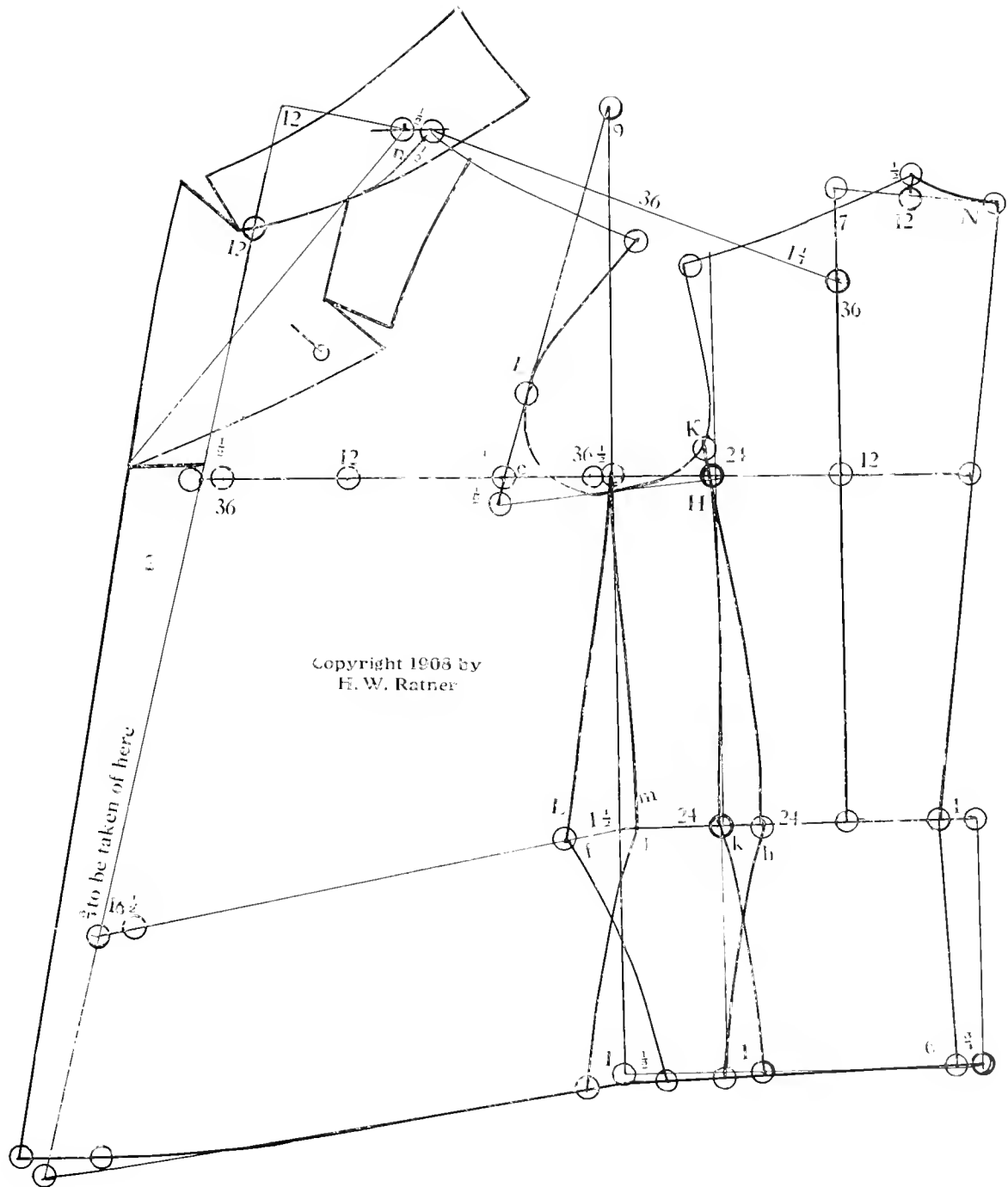

Diagram No. 8.

Ratner's Up-To-Date Method of Designing

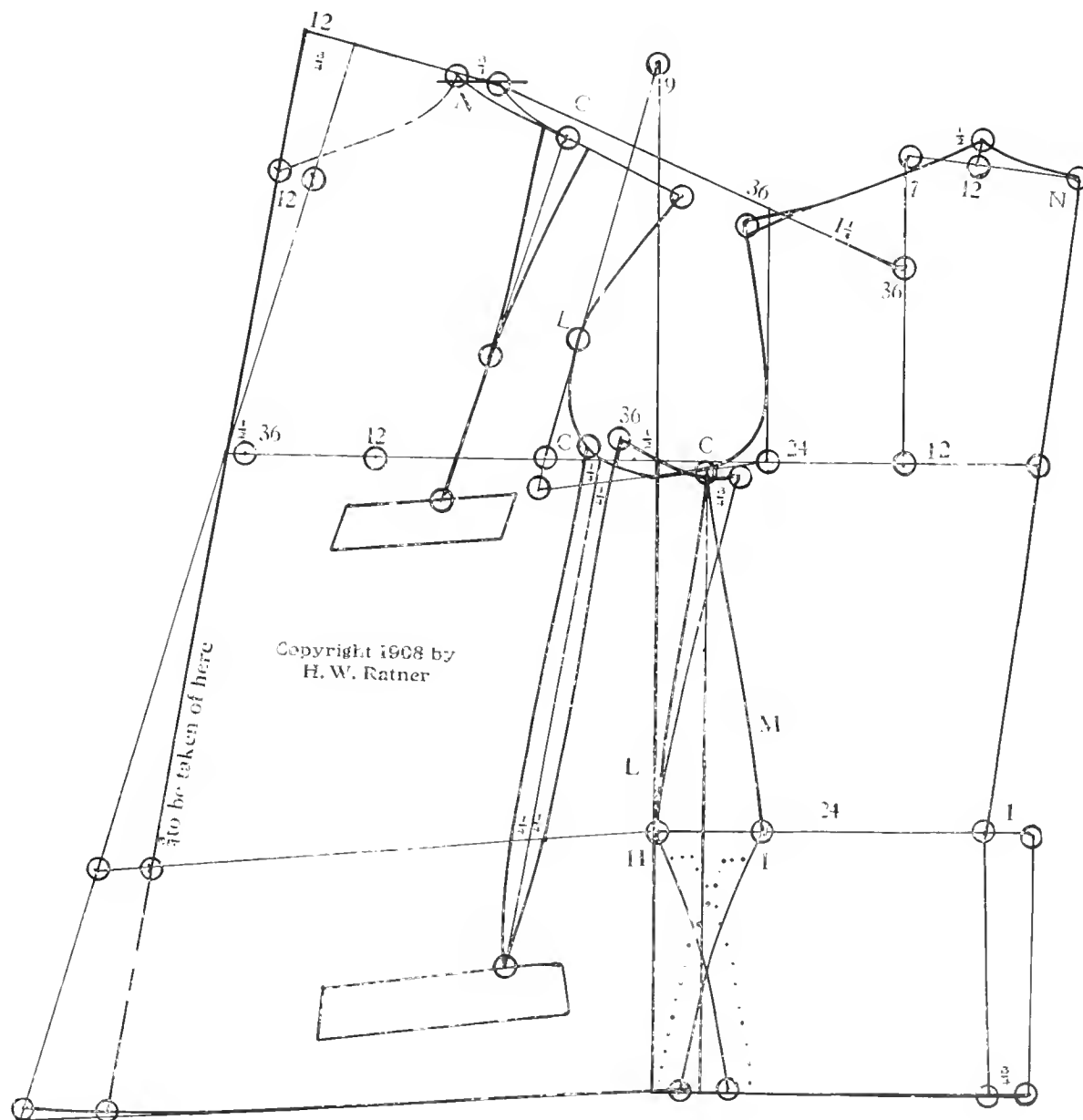

Diagram No. 9.

Ratner's Up-to-Date Method of Designing

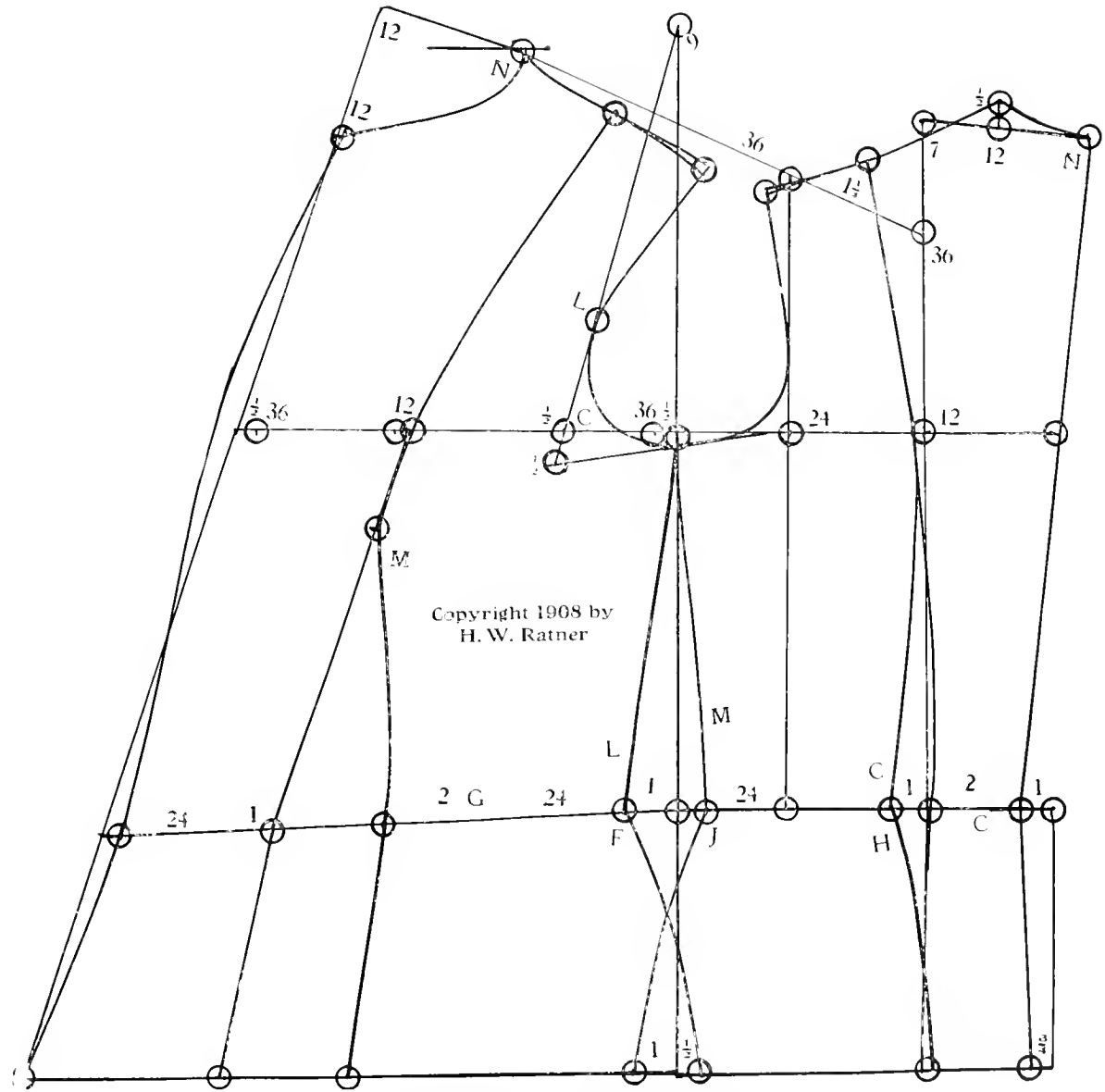
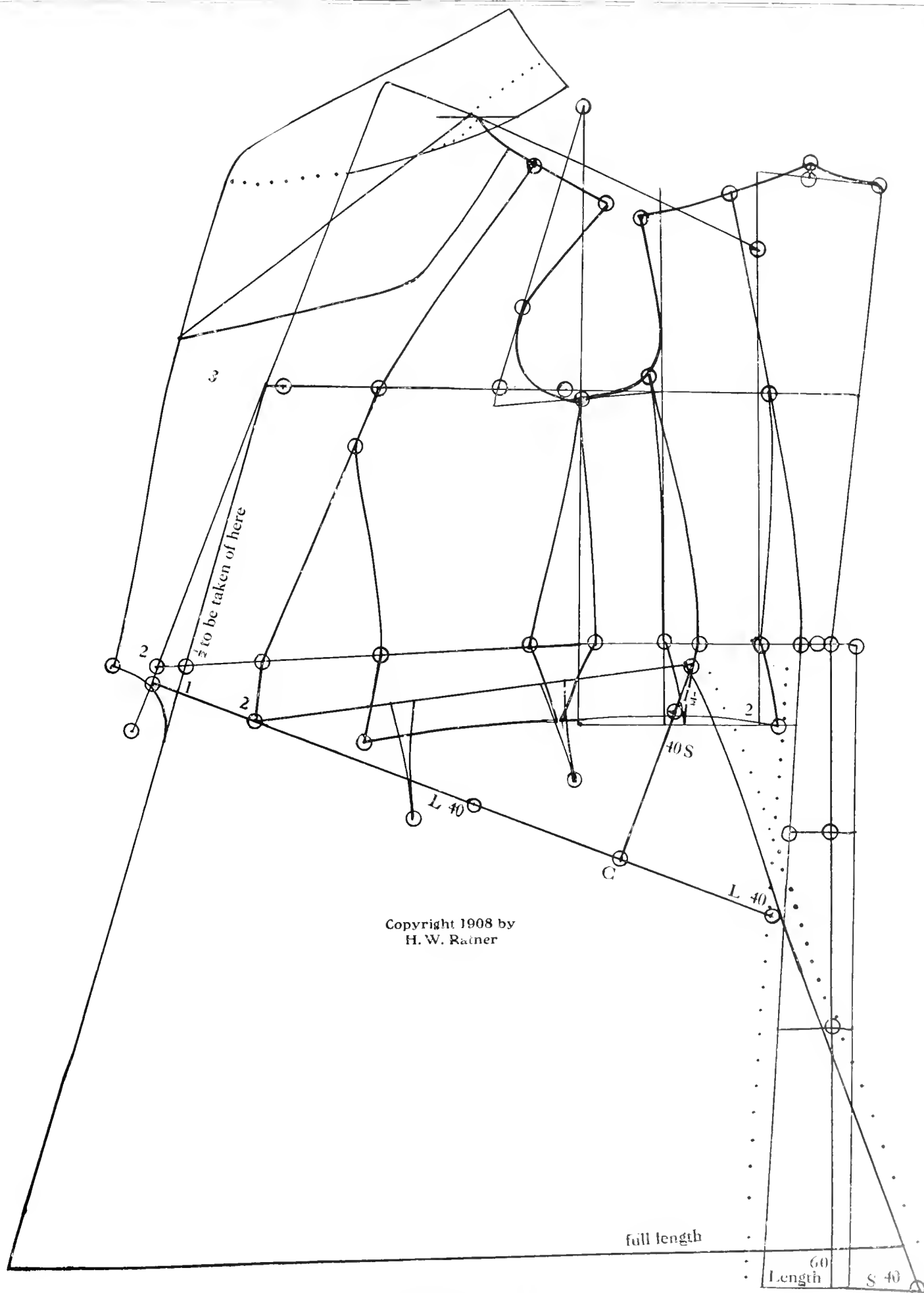

Diagram No. 10.

Ratner's Up-to-Date Method of Designing



Copyright 1908 by
H. W. Ratner

Diagram 11.

Ratner's Up-to-Date Method of Designing

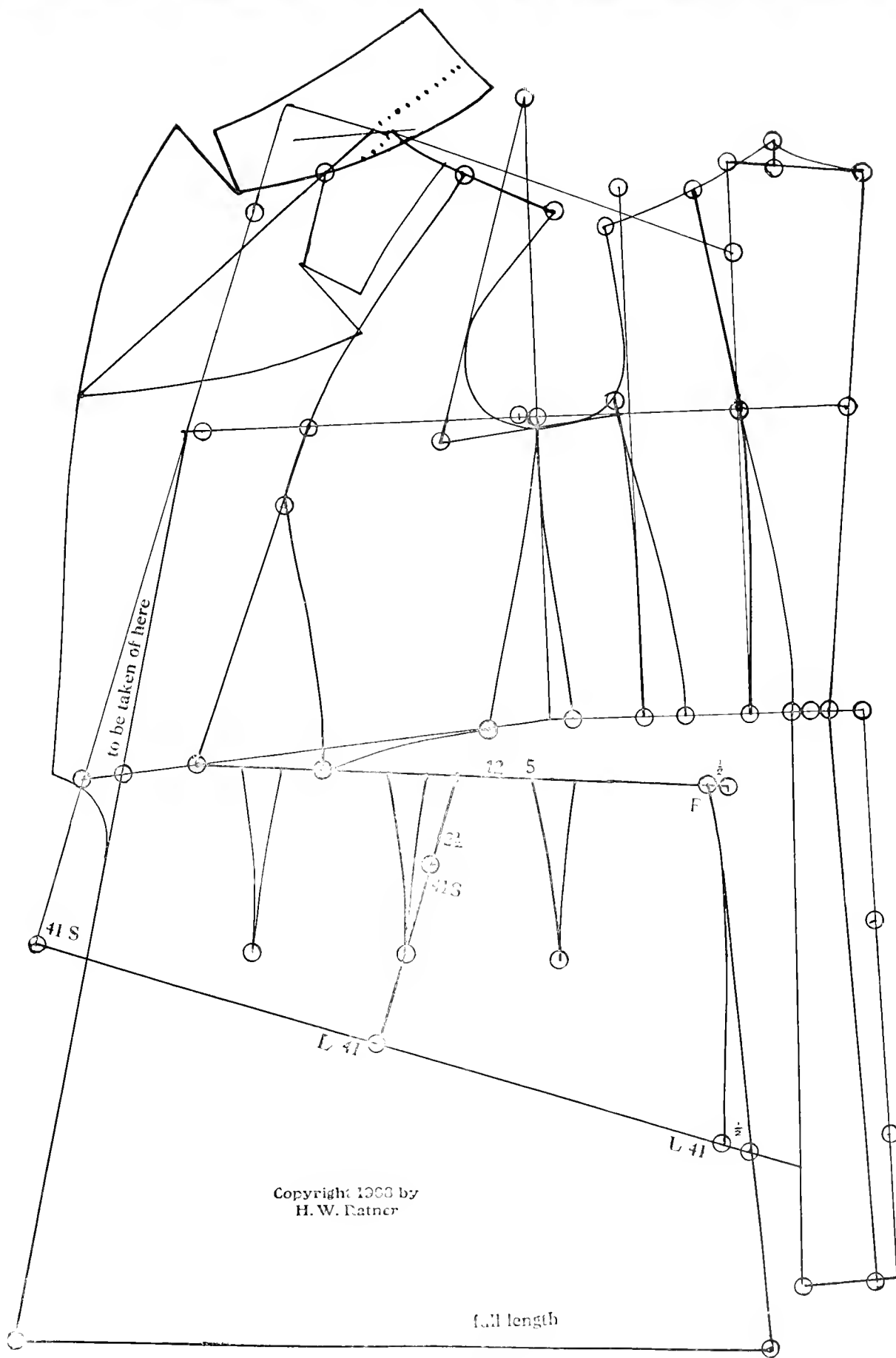

Diagram No. 12.

Ratner's Up-To-Date Method of Designing

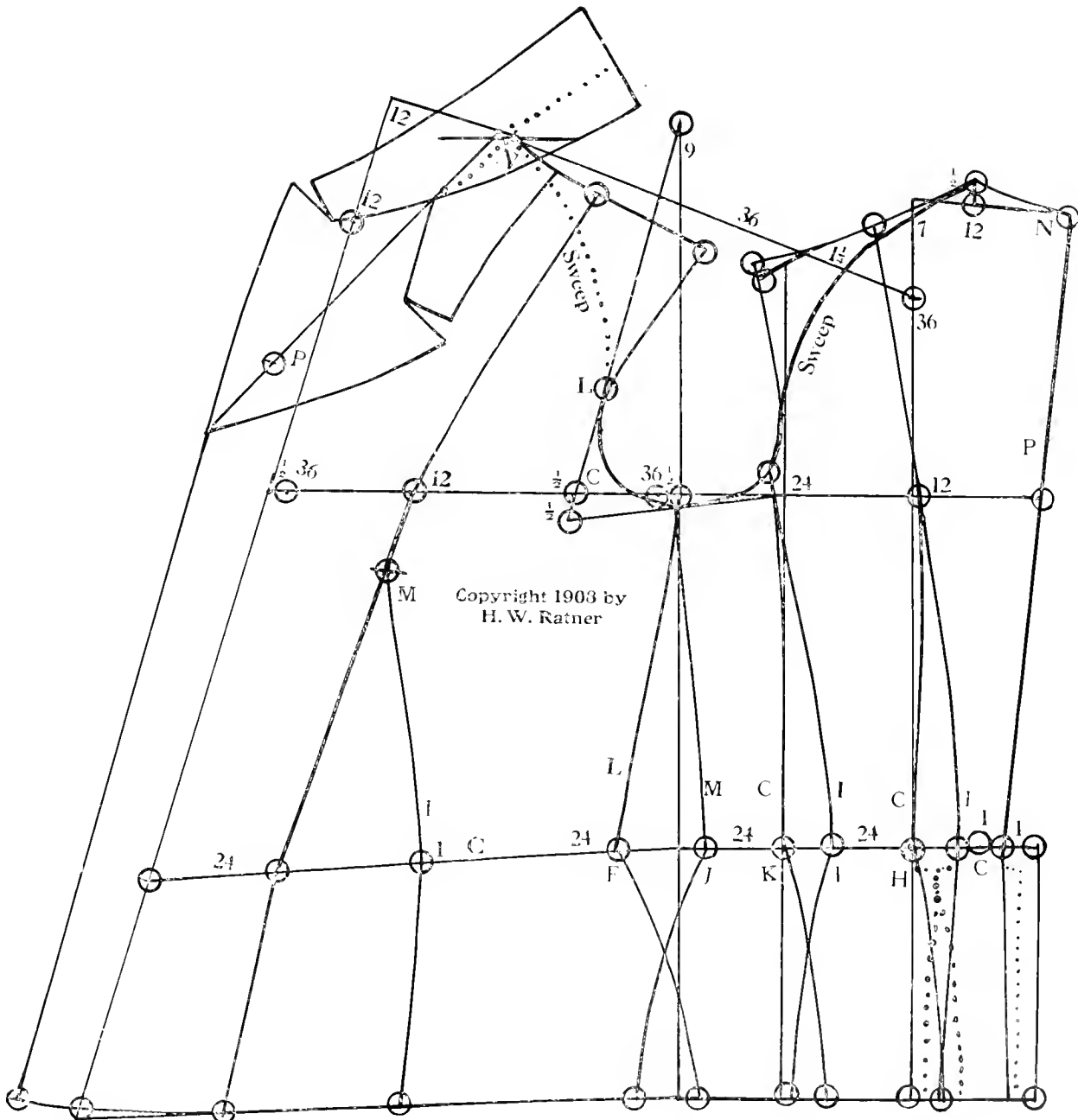

Diagram No. 13.

Ratner's Up-to-Date Method of Designing

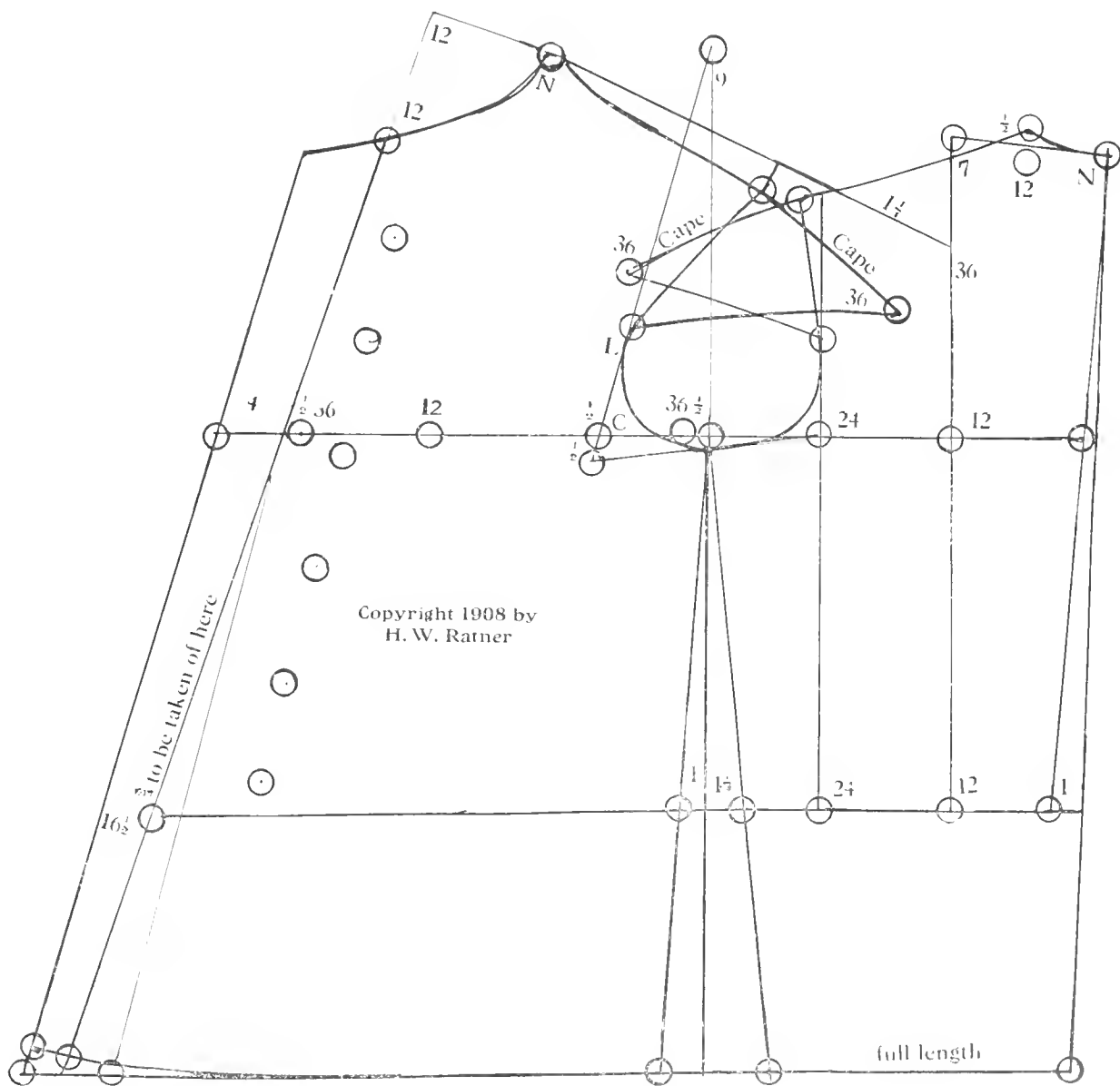

Diagram 14.

Ratner's Up-to-Date Method of Designing

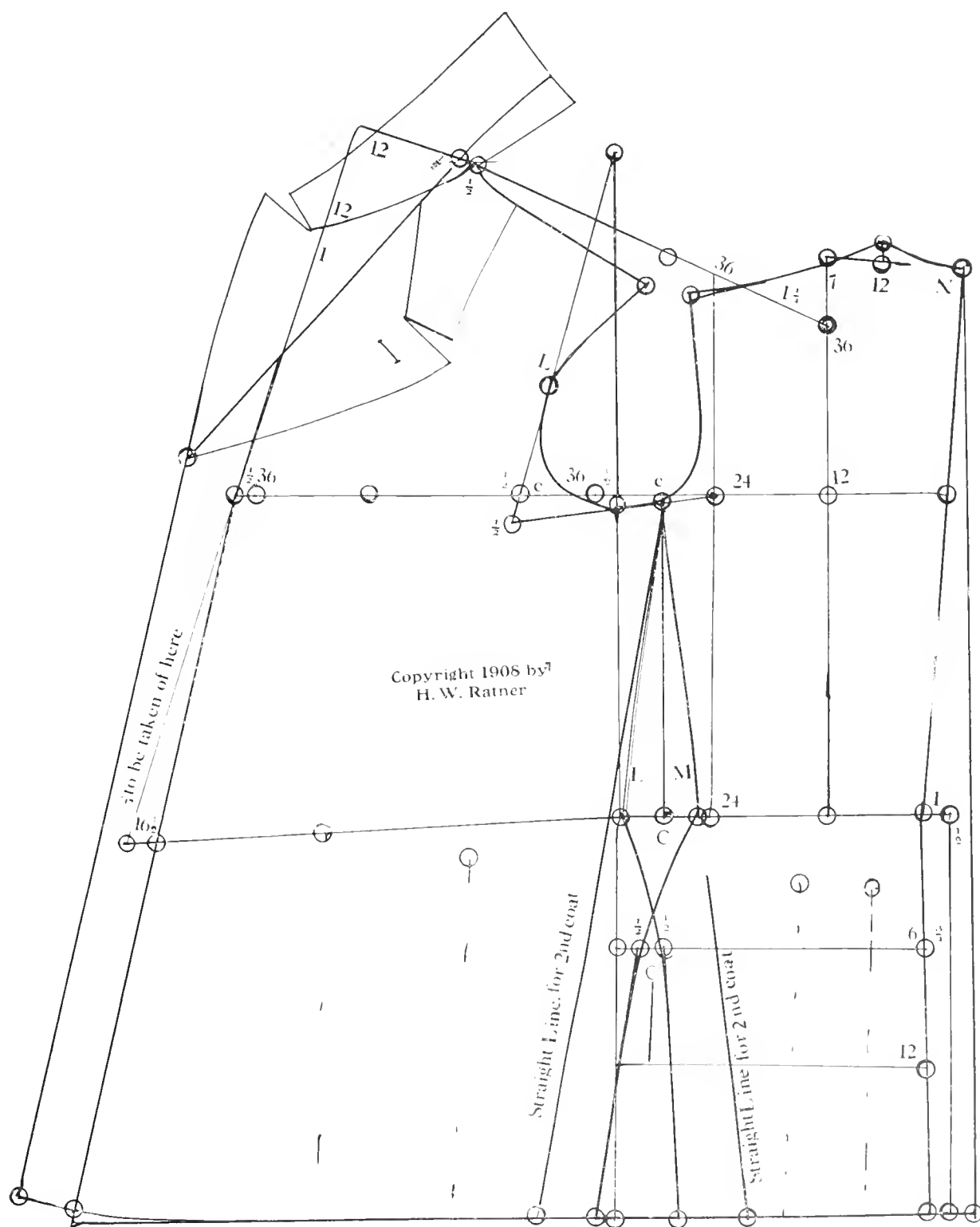

Diagram No. 15.

Ratner's Up-To-Date Method of Designing

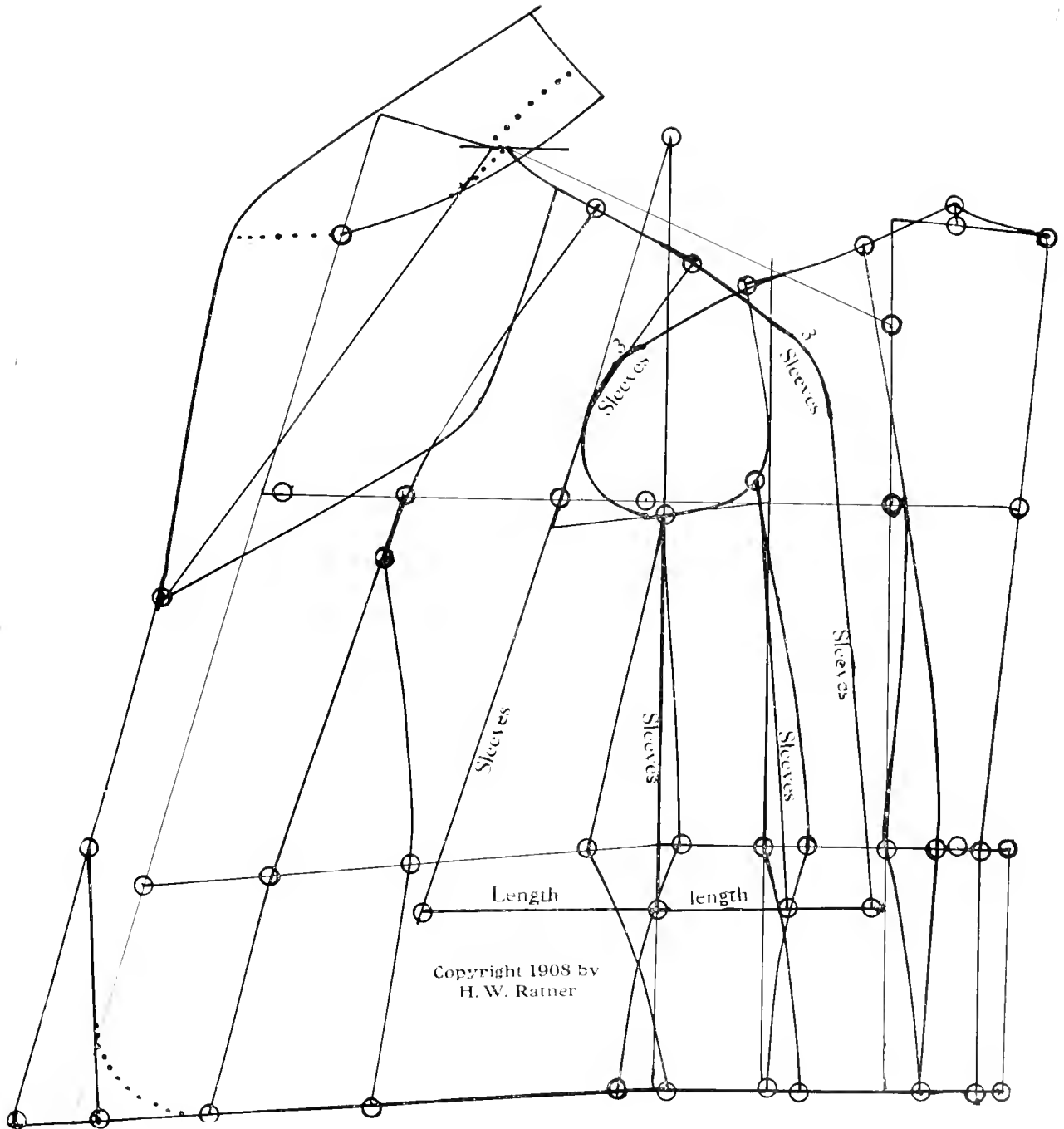

Diagram 16.

Ratner's Up-Co-Date Method of Designing

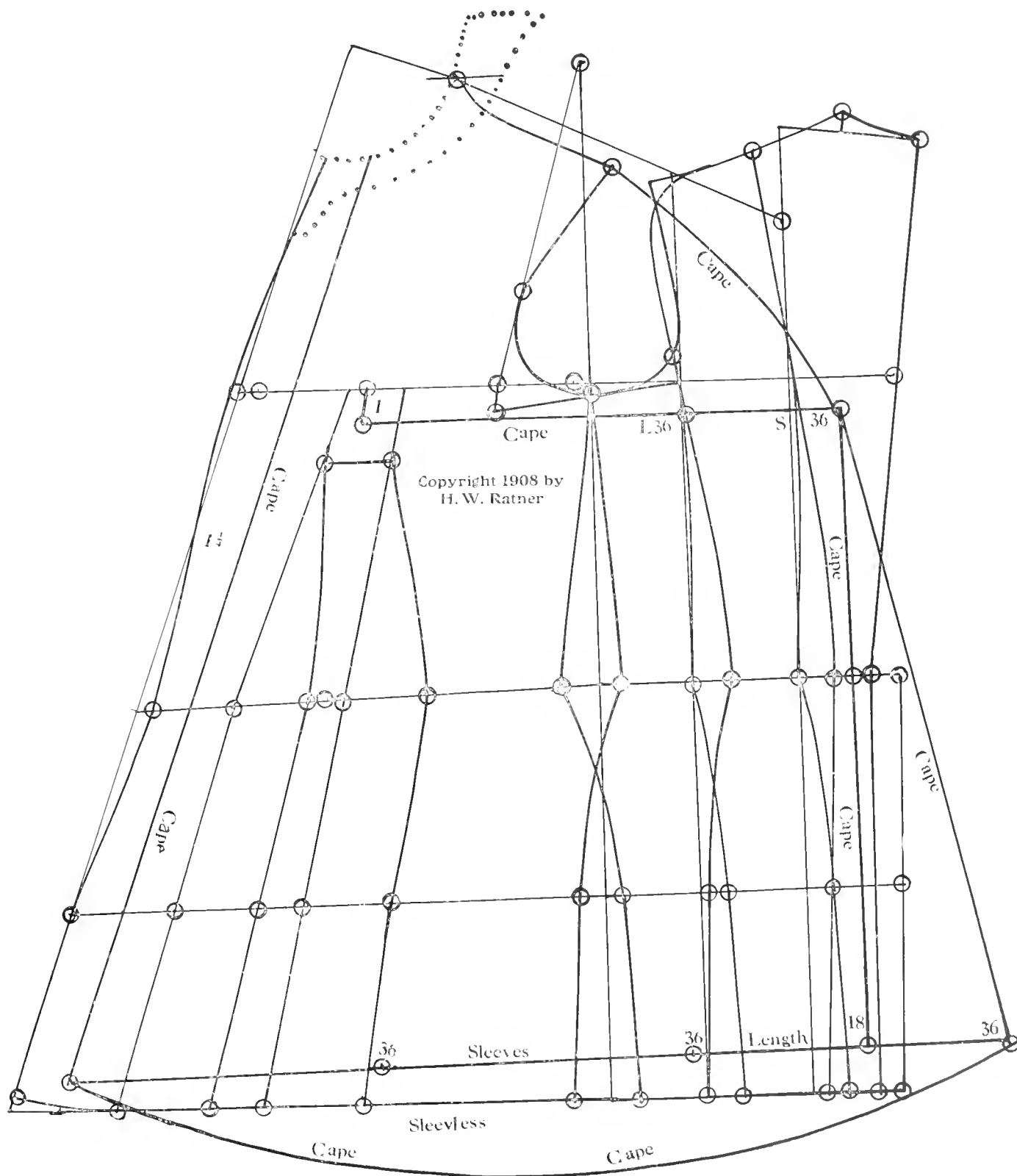

Diagram No. 17.

Printed by the Government Printer, Ottawa, Ontario, Canada

Ratner's Up-To-Date Method of Designing

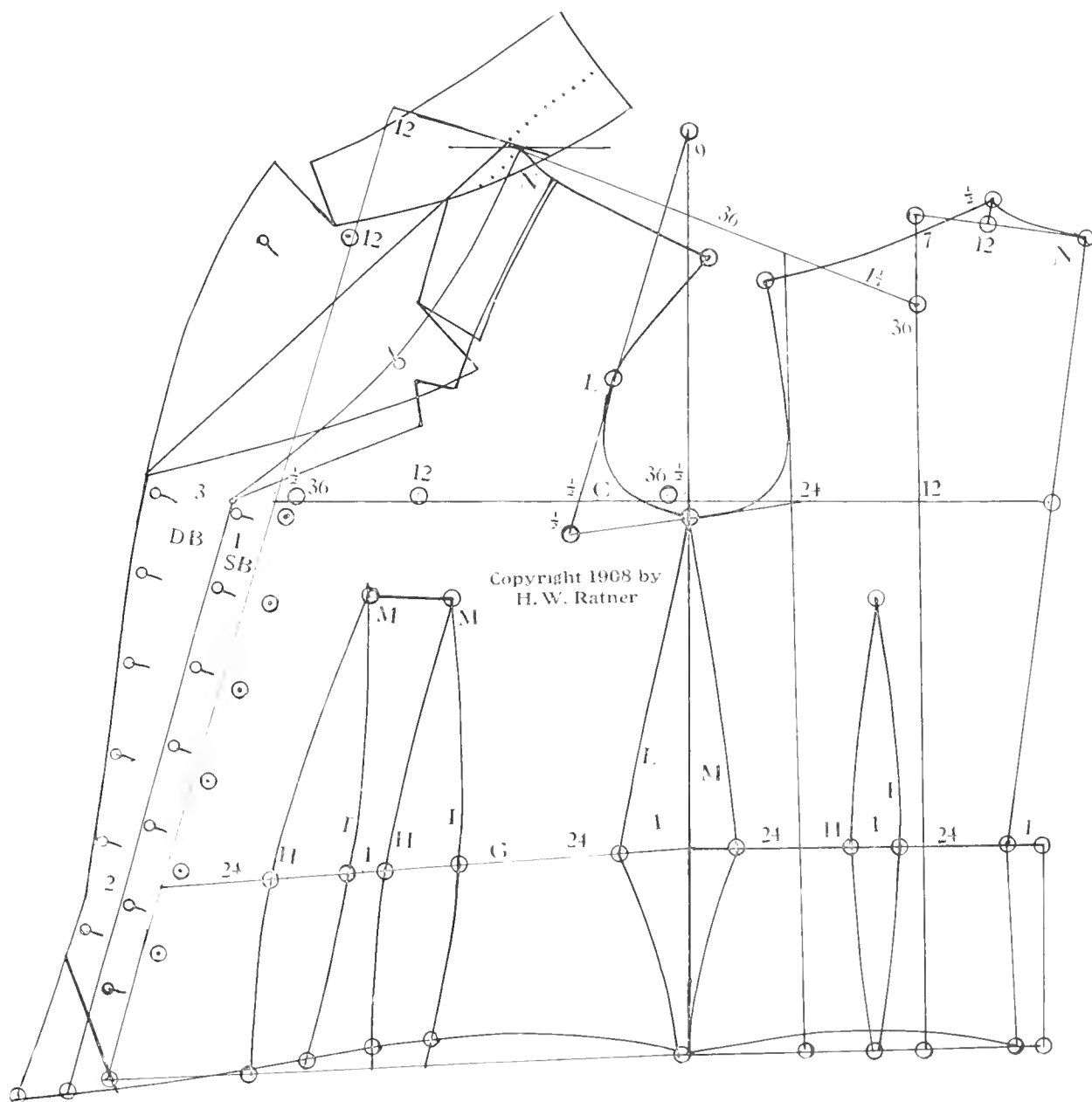

Diagram No. 18.

Ratner's Up-to-Date Method of Designing

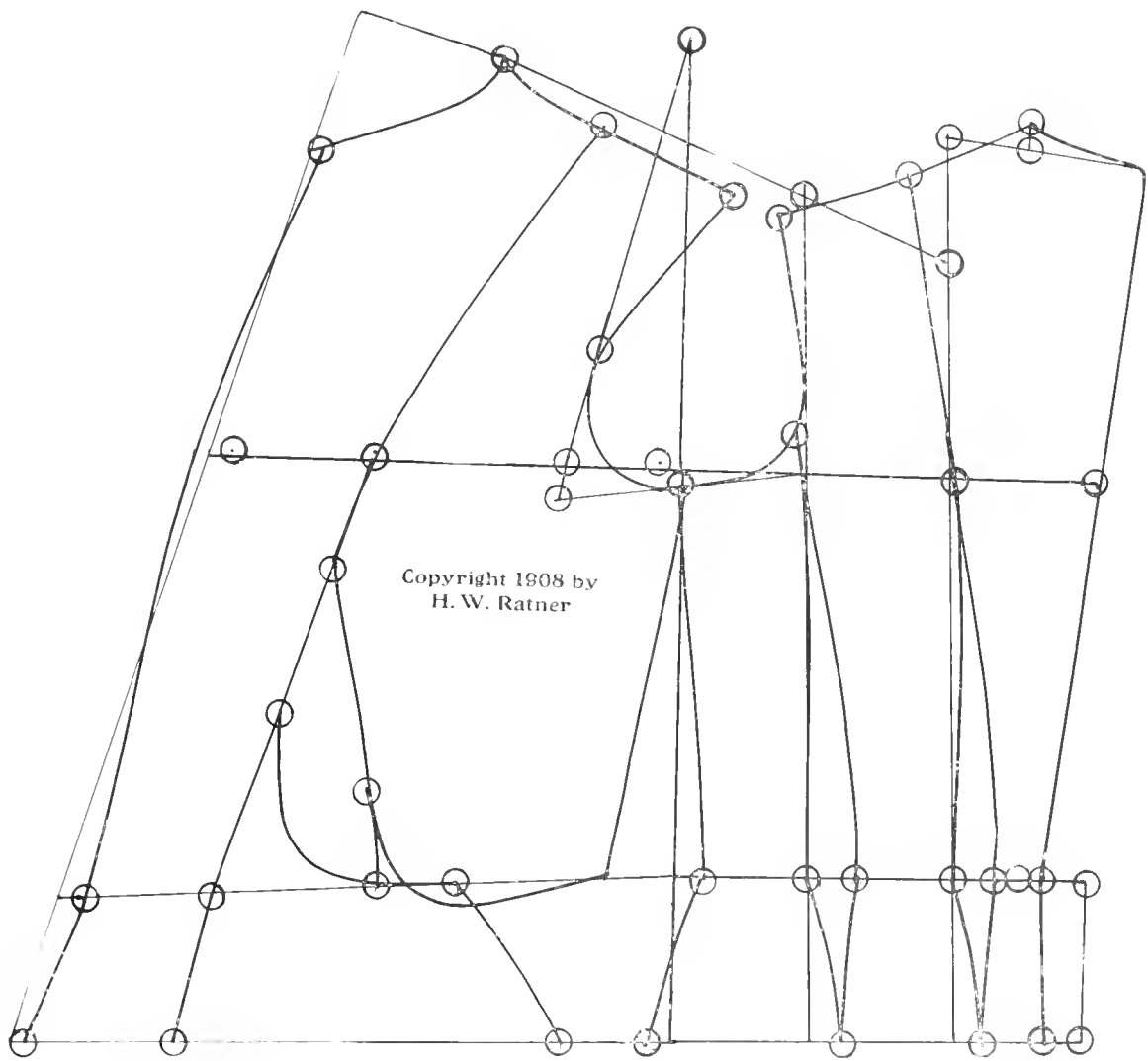

Diagram 19.

Ratner's Up-to-Date Method of Designing

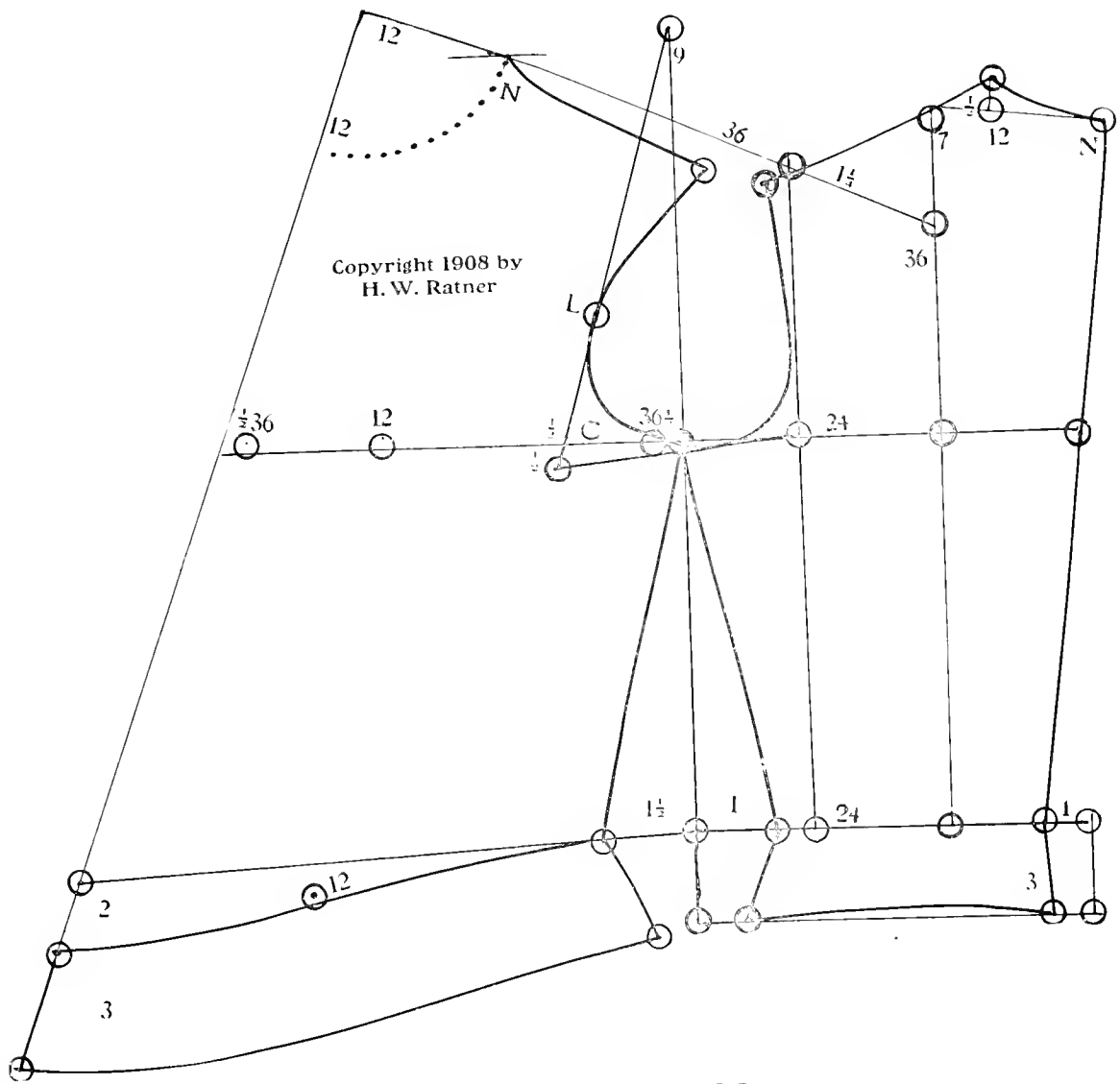

Diagram No. 20.

Ratner's Up-Co-Date Method of Designing

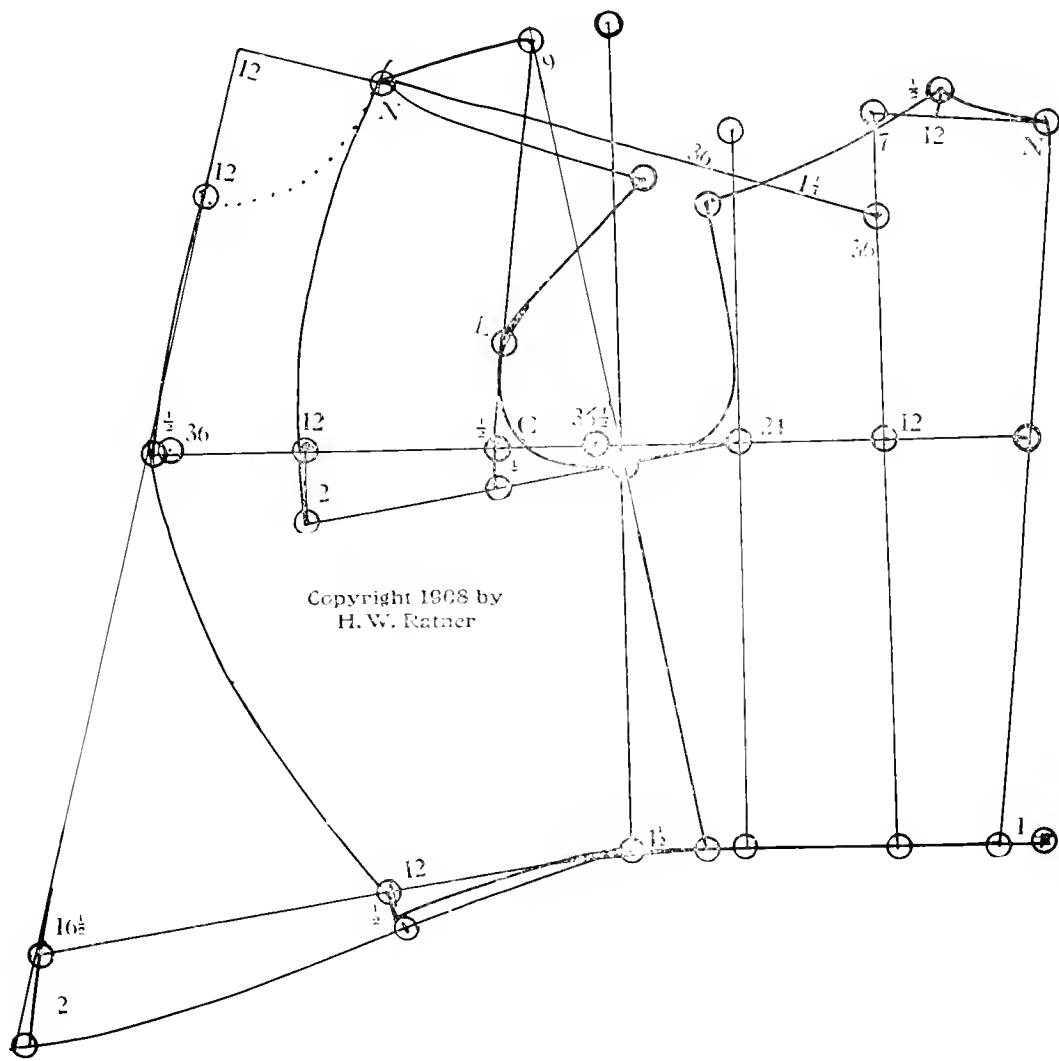

Diagram 21.

1917
1918
1919
1920
1921
1922
1923
1924
1925
1926
1927
1928
1929
1930
1931
1932
1933
1934
1935
1936
1937
1938
1939
1940
1941
1942
1943
1944
1945
1946
1947
1948
1949
1950
1951
1952
1953
1954
1955
1956
1957
1958
1959
1960
1961
1962
1963
1964
1965
1966
1967
1968
1969
1970
1971
1972
1973
1974
1975
1976
1977
1978
1979
1980
1981
1982
1983
1984
1985
1986
1987
1988
1989
1990
1991
1992
1993
1994
1995
1996
1997
1998
1999
2000
2001
2002
2003
2004
2005
2006
2007
2008
2009
2010
2011
2012
2013
2014
2015
2016
2017
2018
2019
2020
2021
2022
2023
2024
2025

Ratner's Up-To-Date Method of Designing

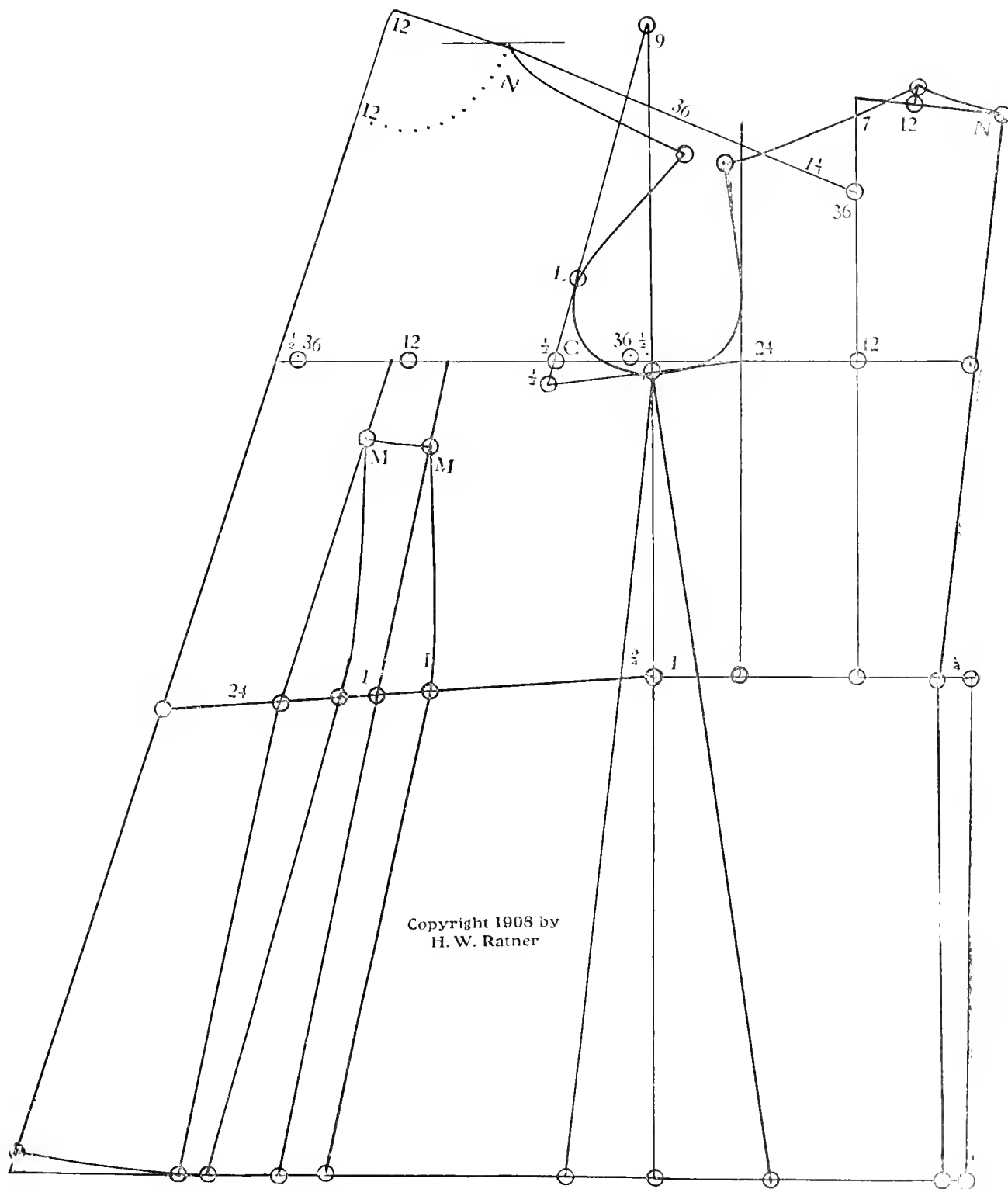

Diagram 22.

THE UNIVERSITY OF CHICAGO

PHILOSOPHY DEPARTMENT

PHILOSOPHY 101

LECTURE 1: THE PHENOMENON OF CONSCIOUSNESS

PROFESSOR JOHN DEWEY

CHICAGO, ILLINOIS

1919

101-101-101

101-101-101

101-101-101

101-101-101

101-101-101

101-101-101

101-101-101

101-101-101

101-101-101

101-101-101

101-101-101

101-101-101

101-101-101

101-101-101

101-101-101

101-101-101

101-101-101

101-101-101

101-101-101

101-101-101

101-101-101

101-101-101

101-101-101

101-101-101

101-101-101

101-101-101

Ratner's Up-To-Date Method of Designing

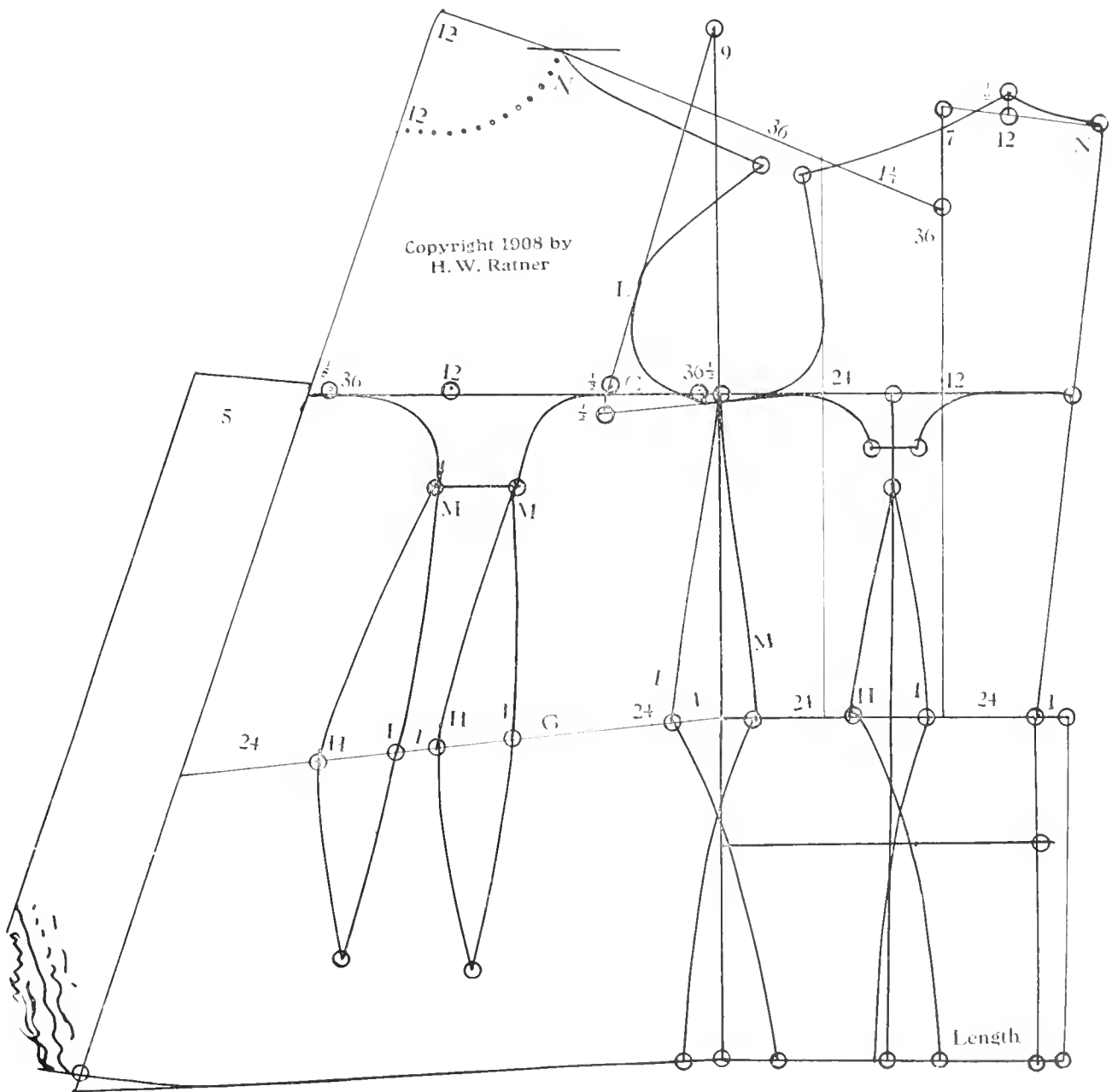

Diagram No. 23.

Ratner's Up-To-Date Method of Designing

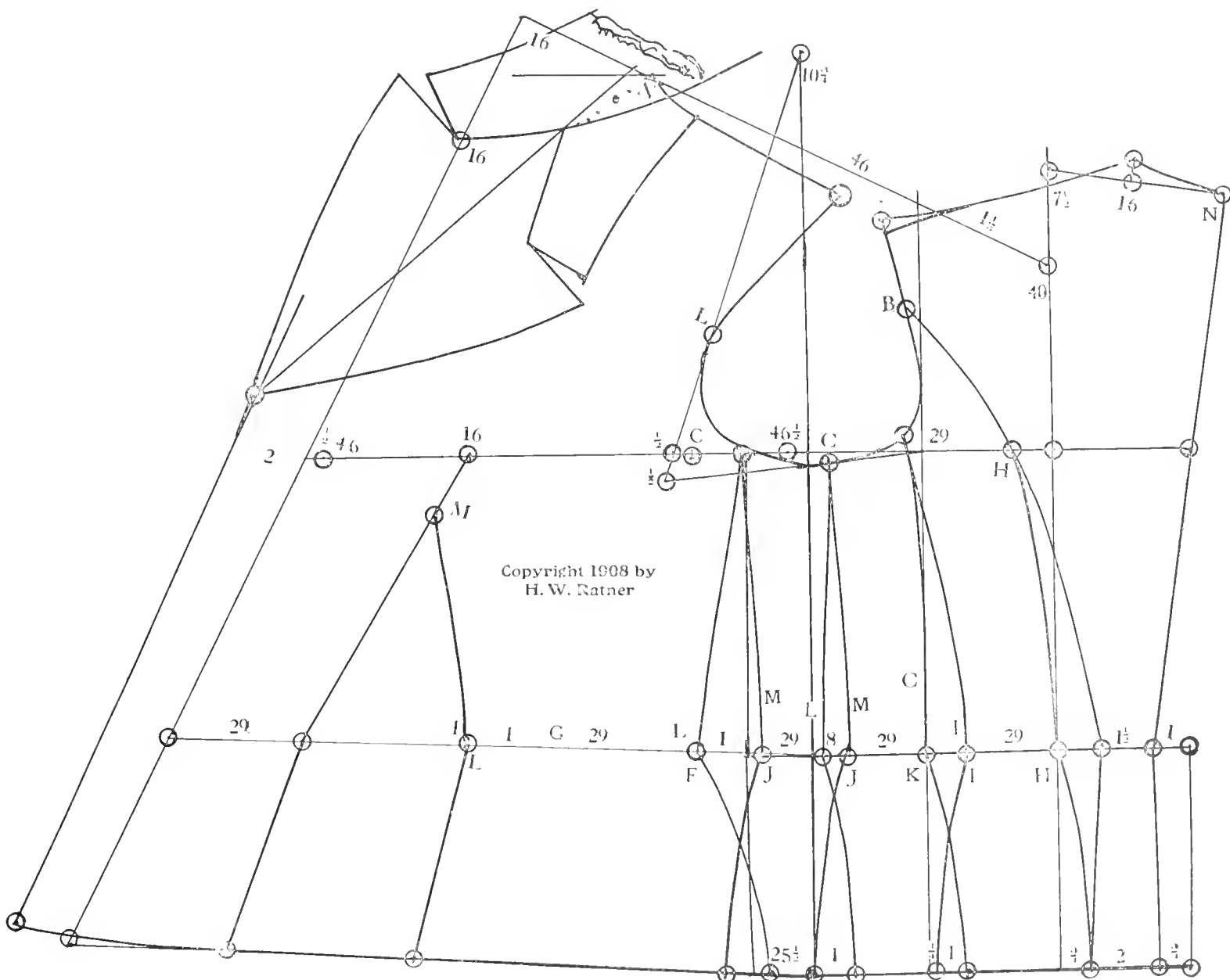

Diagram 24.
Improportion Coat.

Ratner's Up-To-Date Method of Designing

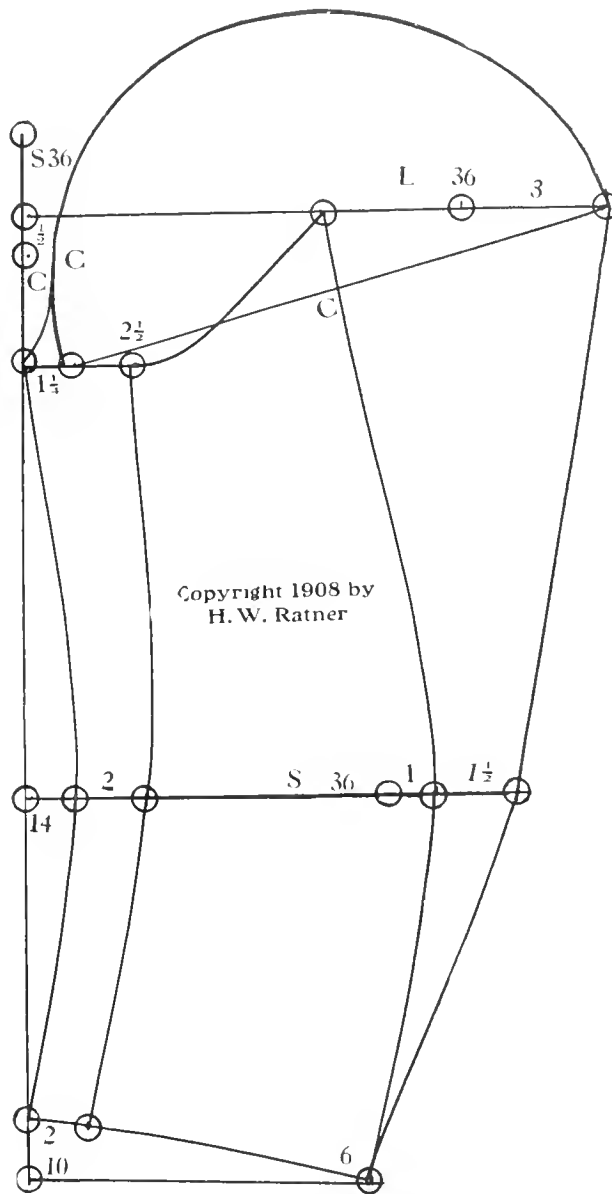

Diagram No. 25.

Ratner's Up-to-Date Method of Designing

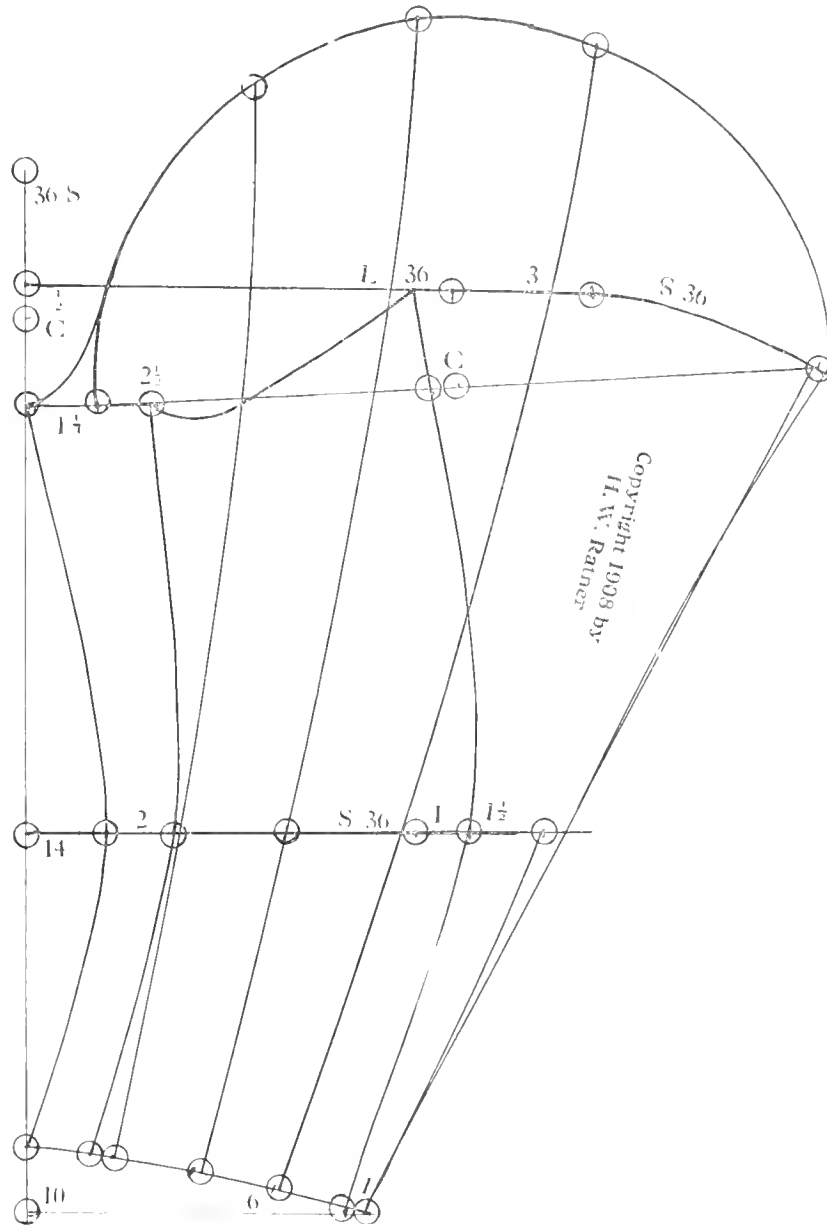
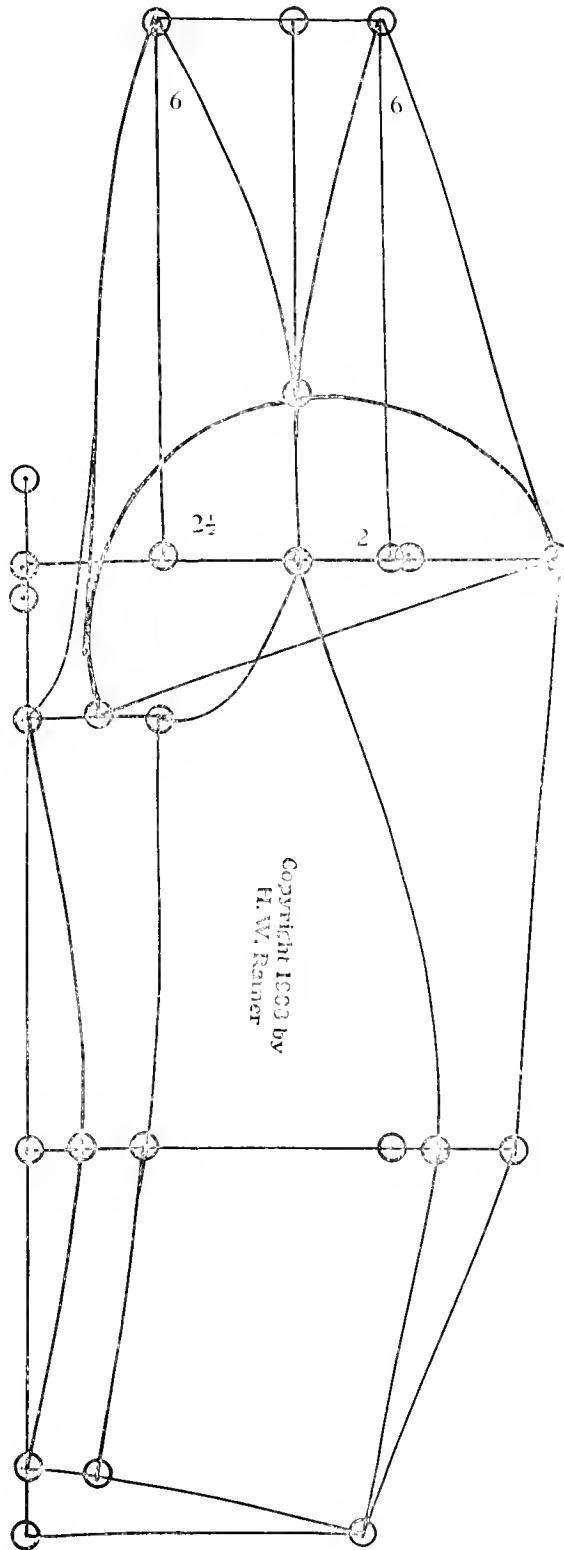

Diagram No. 26.

Ratner's Up-to-Date Method of Designing



Copyright 1903 by
H. W. Ratner

Diagram 27.

Ratner's Up-to-Date Method of Designing

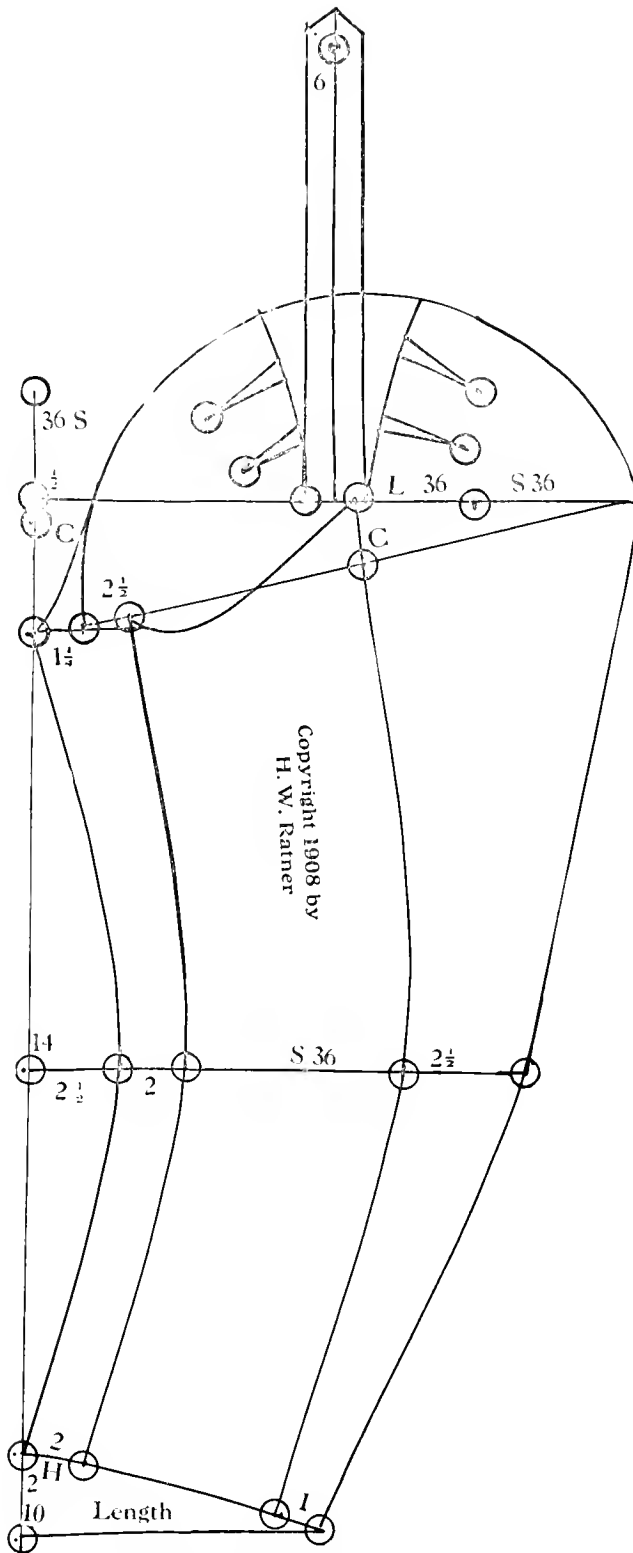

Diagram No. 28.

Ratner's Up-To-Date Method of Designing

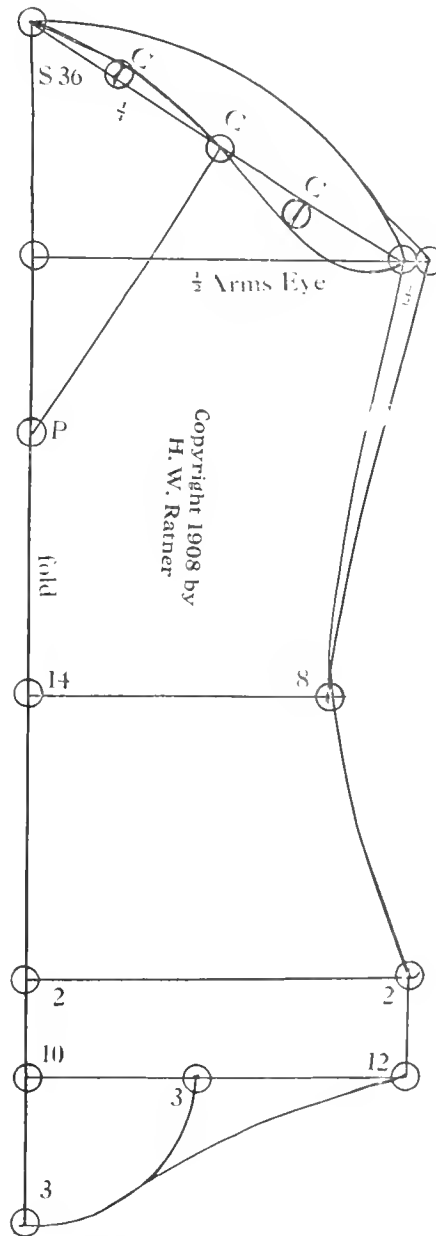

Diagram 29.

Ratner's Up-To-Date Method of Designing

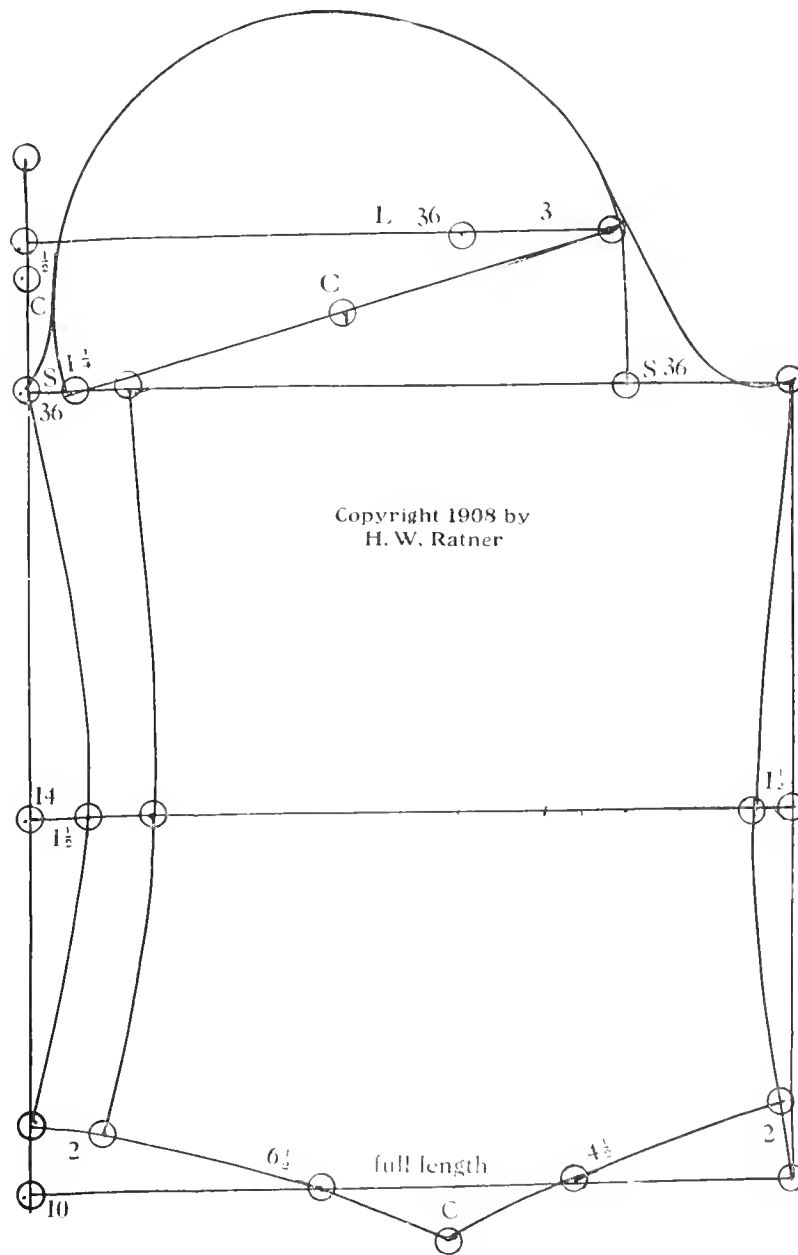

Diagram No. 30.

Ratner's Up-To-Date Method of Designing

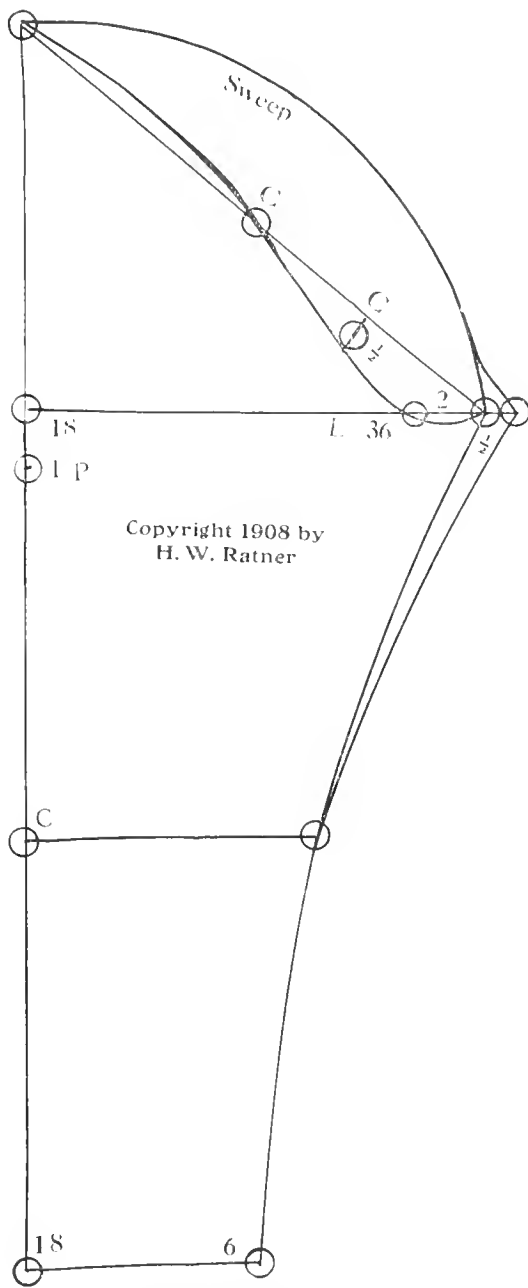

Diagram 31.

Ratner's Up-to-Date Method of Designing

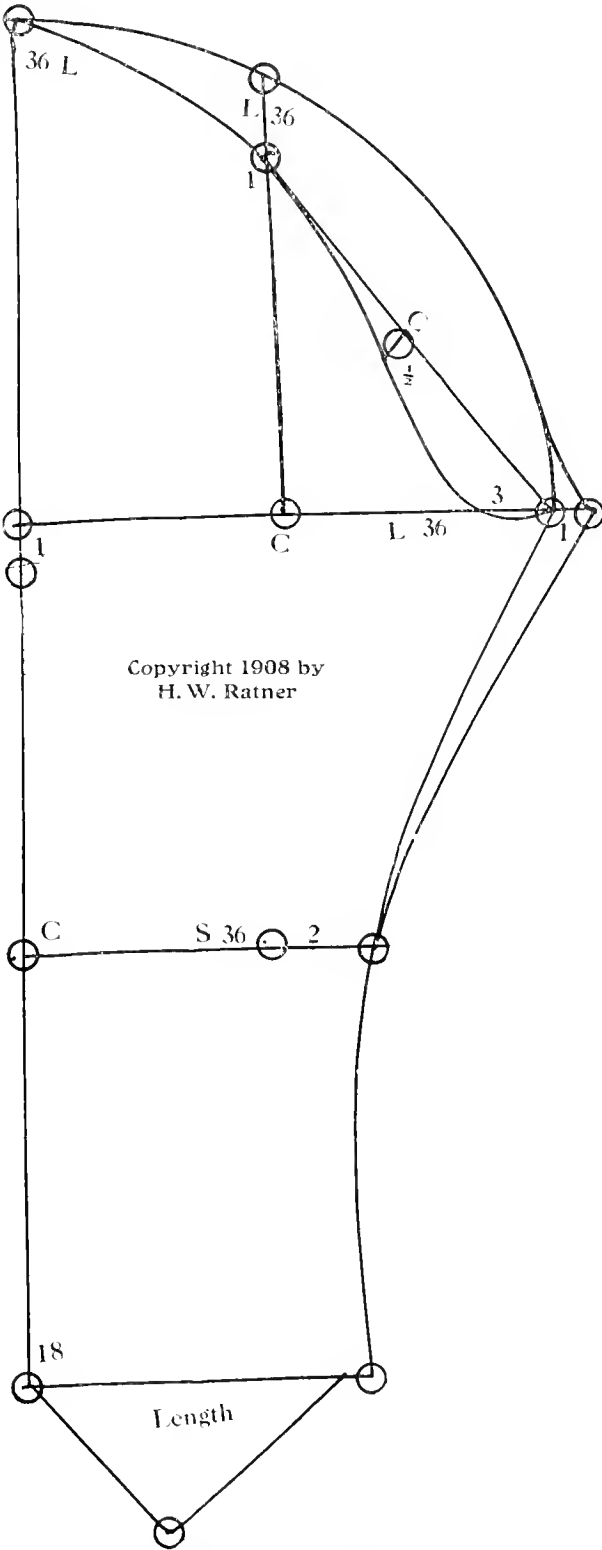

Diagram No. 32.

Ratner's Up-to-Date Method of Designing

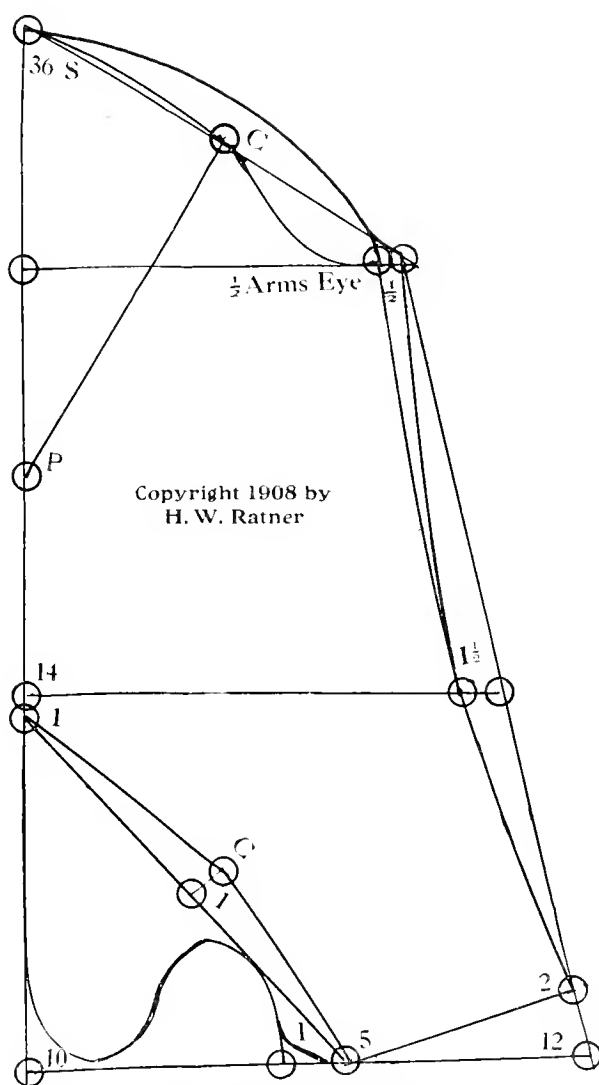
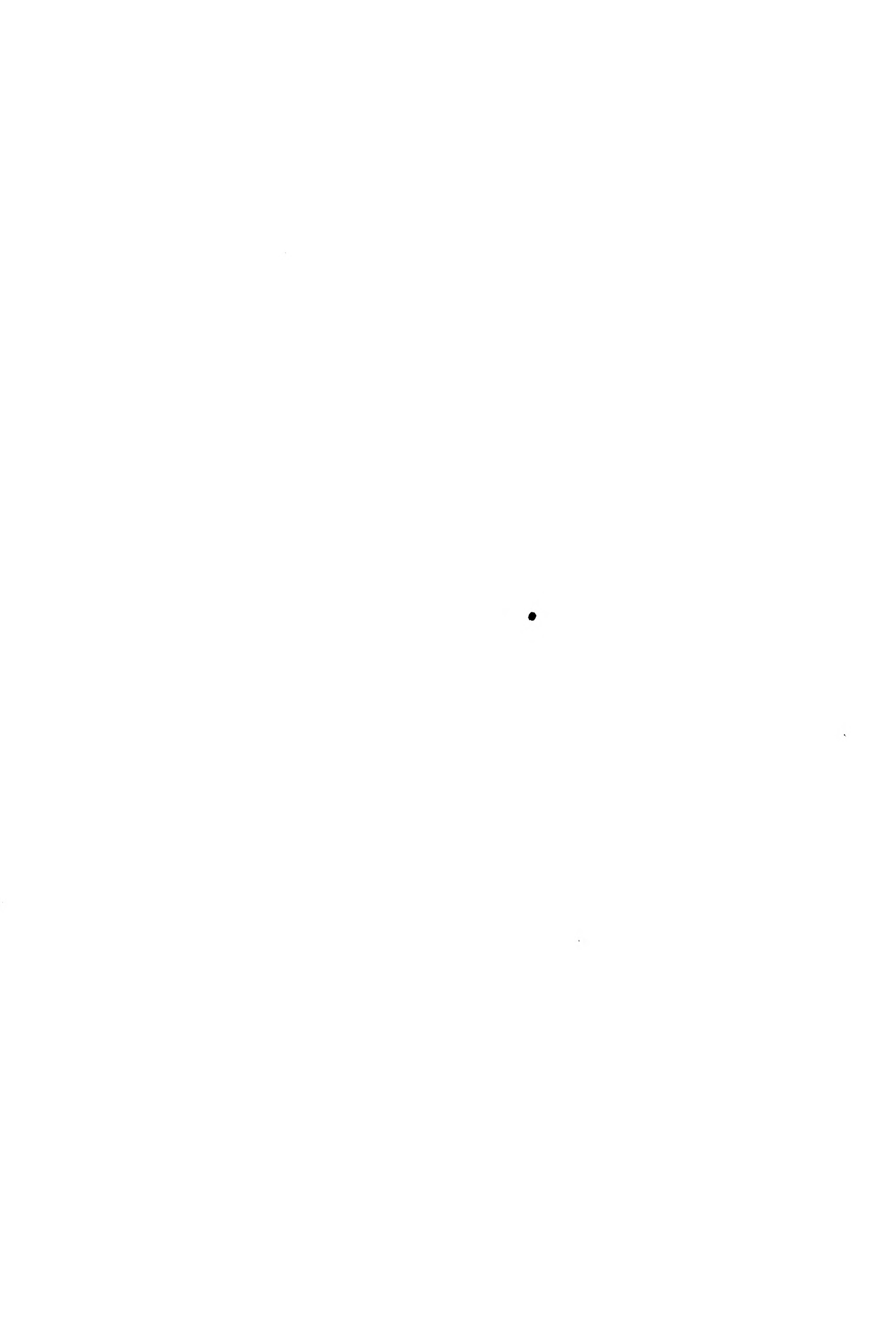

Diagram 33.



Ratner's Up-To-Date Method of Designing

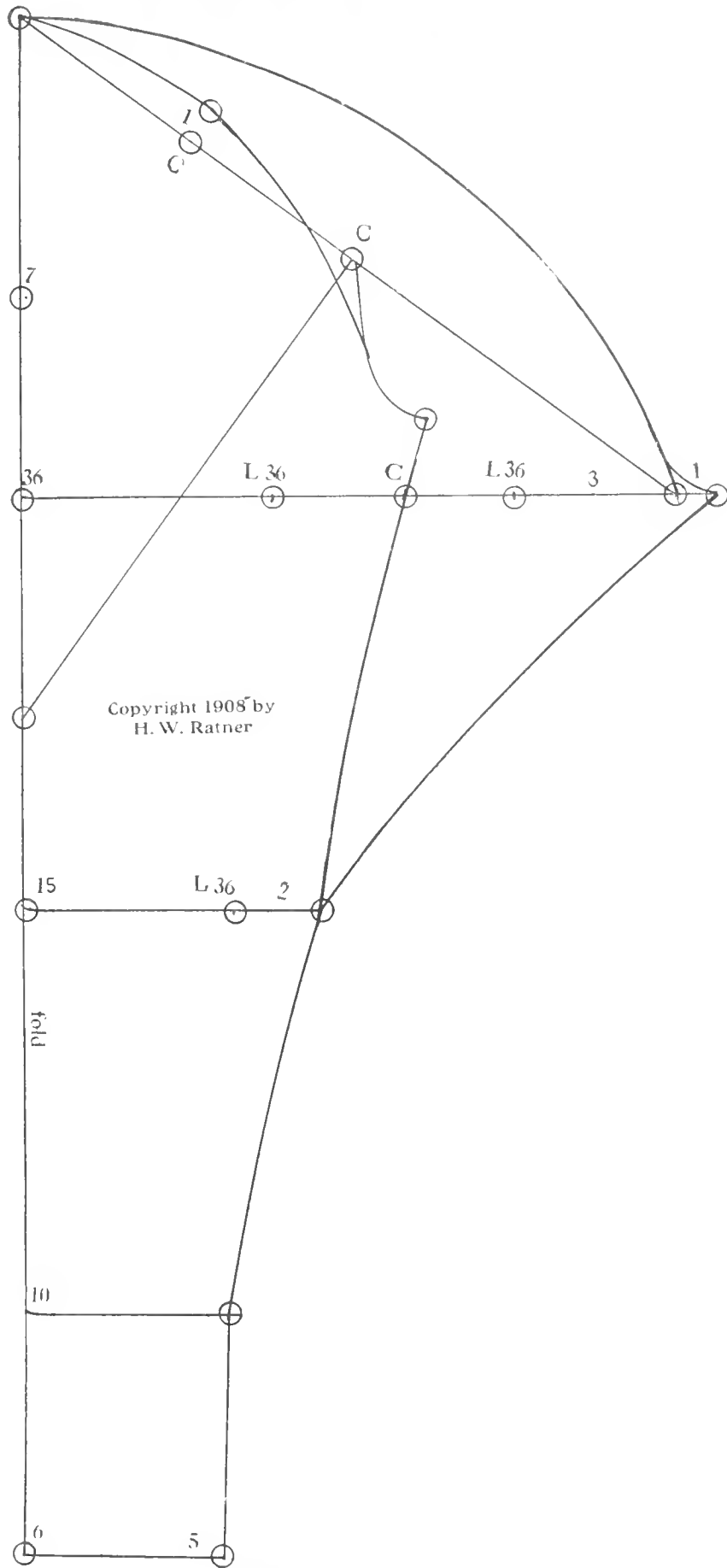
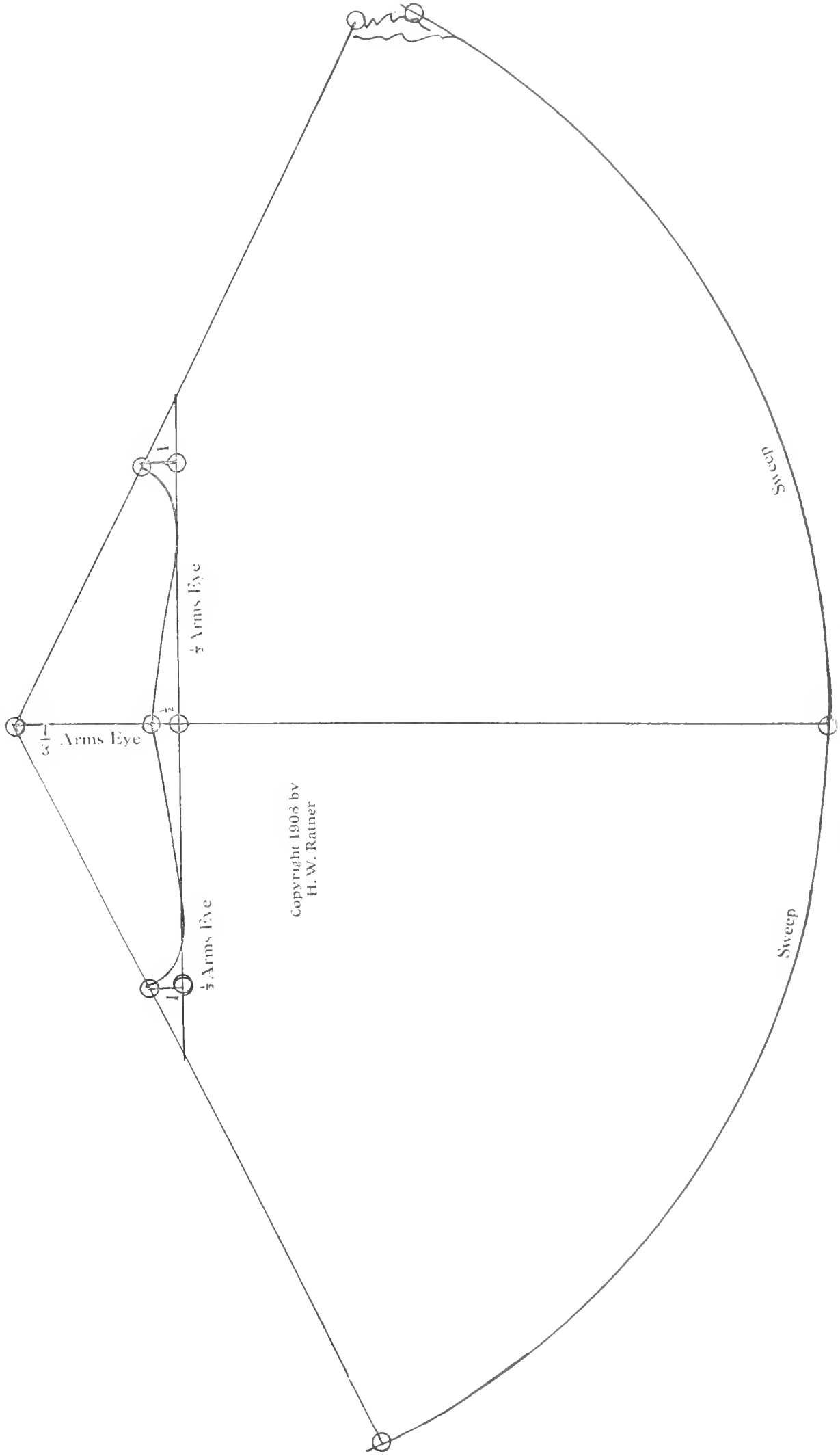

Diagram 35.



Ratner's Up-to-Date Method of Designing



Copyright 1908 by
H. W. Ratner

Diagram No. 36.

Ratner's Up-to-Date Method of Designing

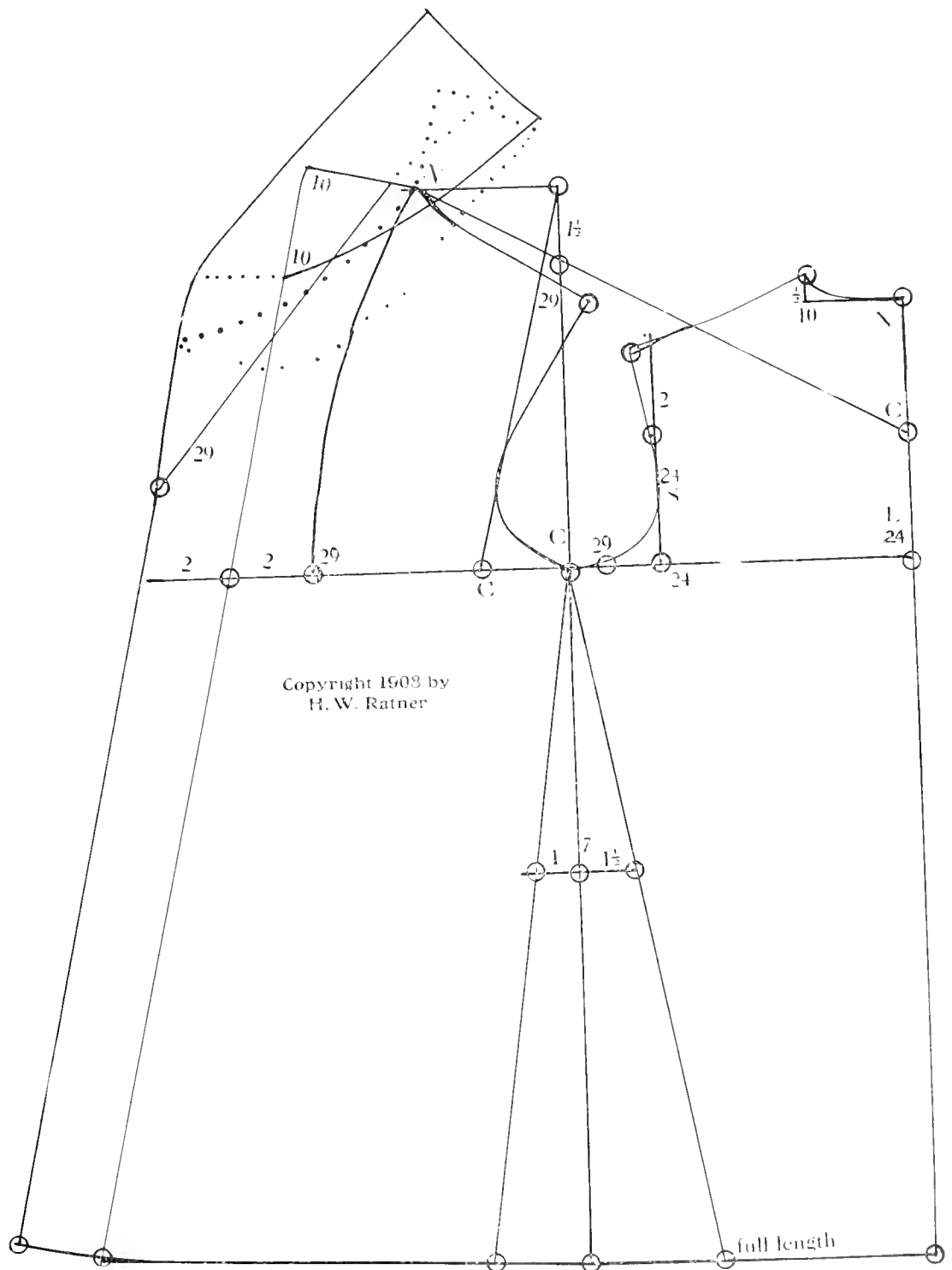

Diagram No. 37.

Ratner's Up-To-Date Method of Designing

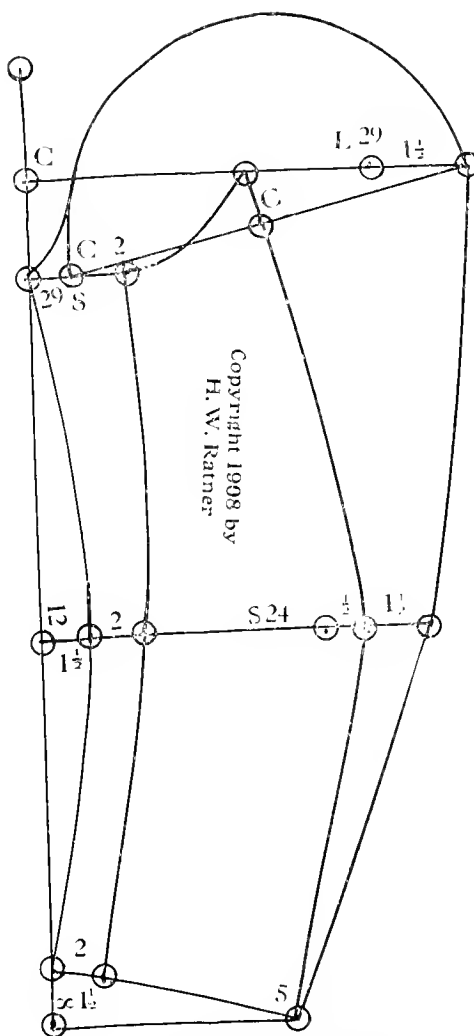

Diagram 38.

Ratner's Up-Co-Date Method of Designing

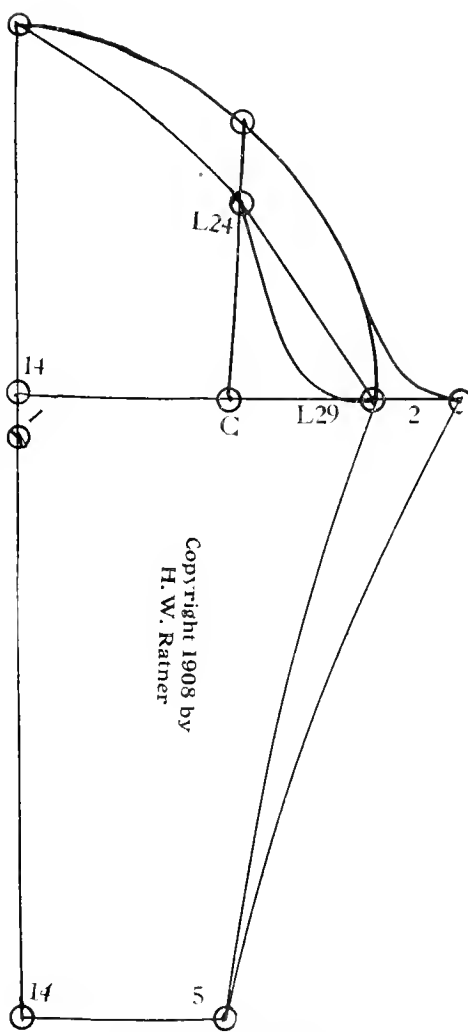
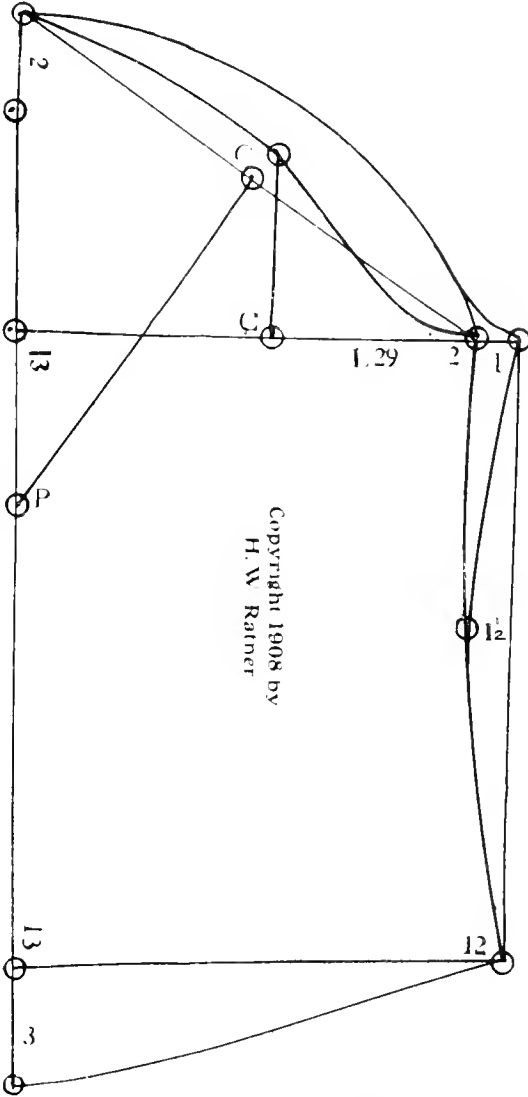

Diagram No. 39.

Ratner's Up-Co-Date Method of Designing



COPYRIGHT 1908 BY
H. W. RATNER

Diagram 40.

Ratner's Up-To-Date Method of Designing

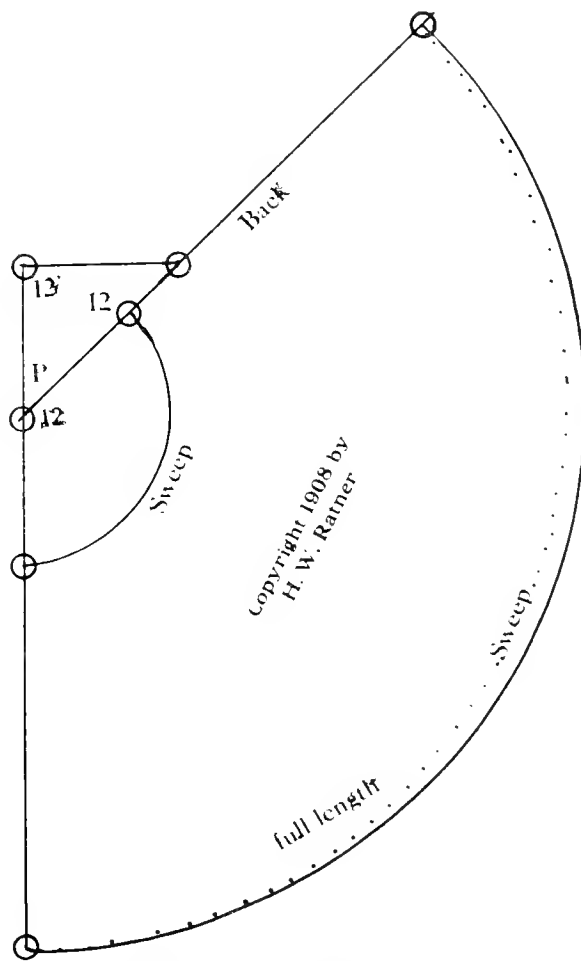

Diagram No. 41.

Ratner's Up-To-Date Method of Designing

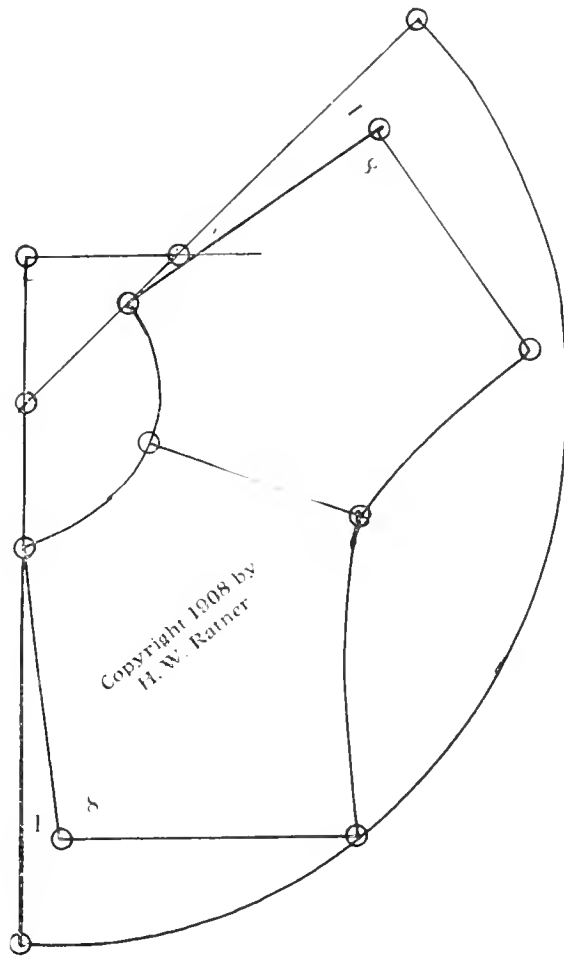

Diagram No. 42.

Ratner's Up-Co-Date Method of Designing

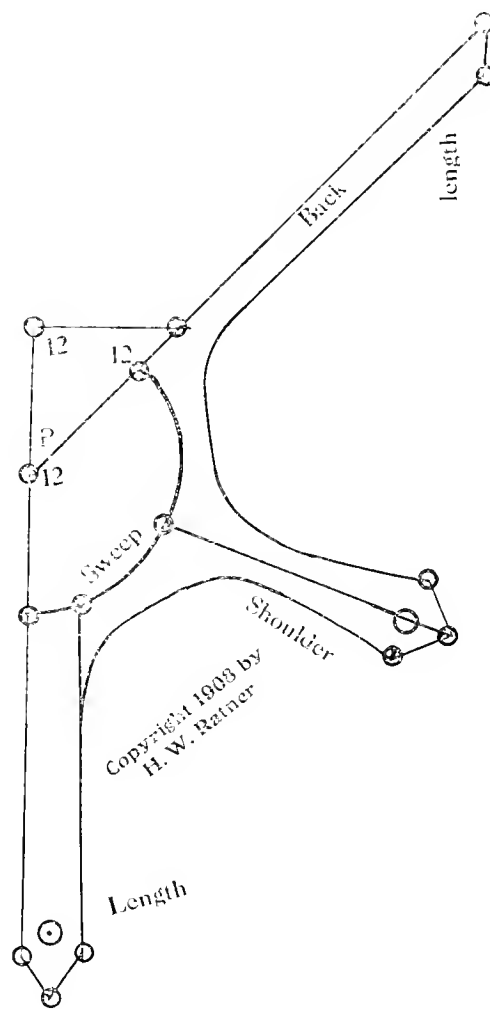

Diagram 43.

Ratner's Up-To-Date Method of Designing

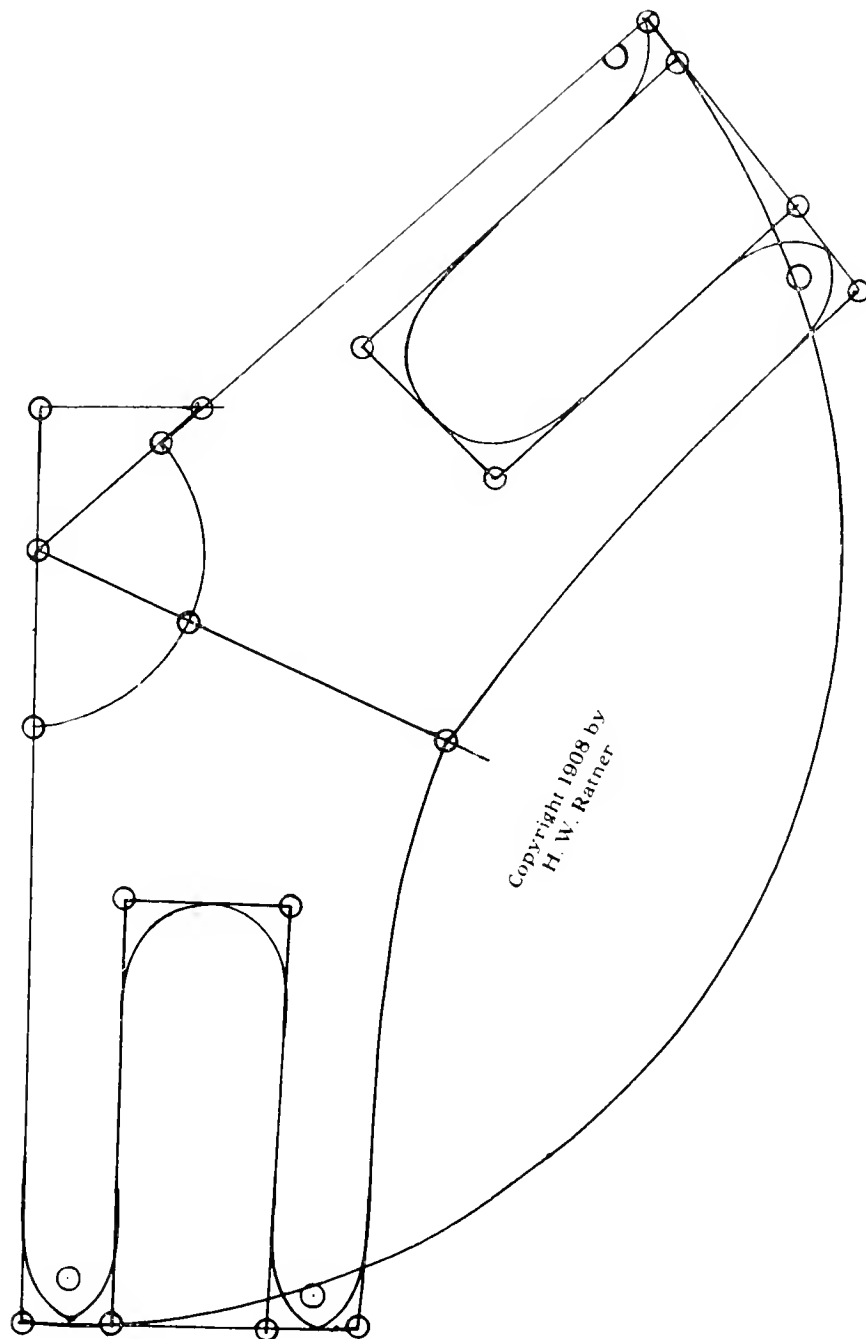

Diagram No. 44.

Ratner's Up-to-Date Method of Designing

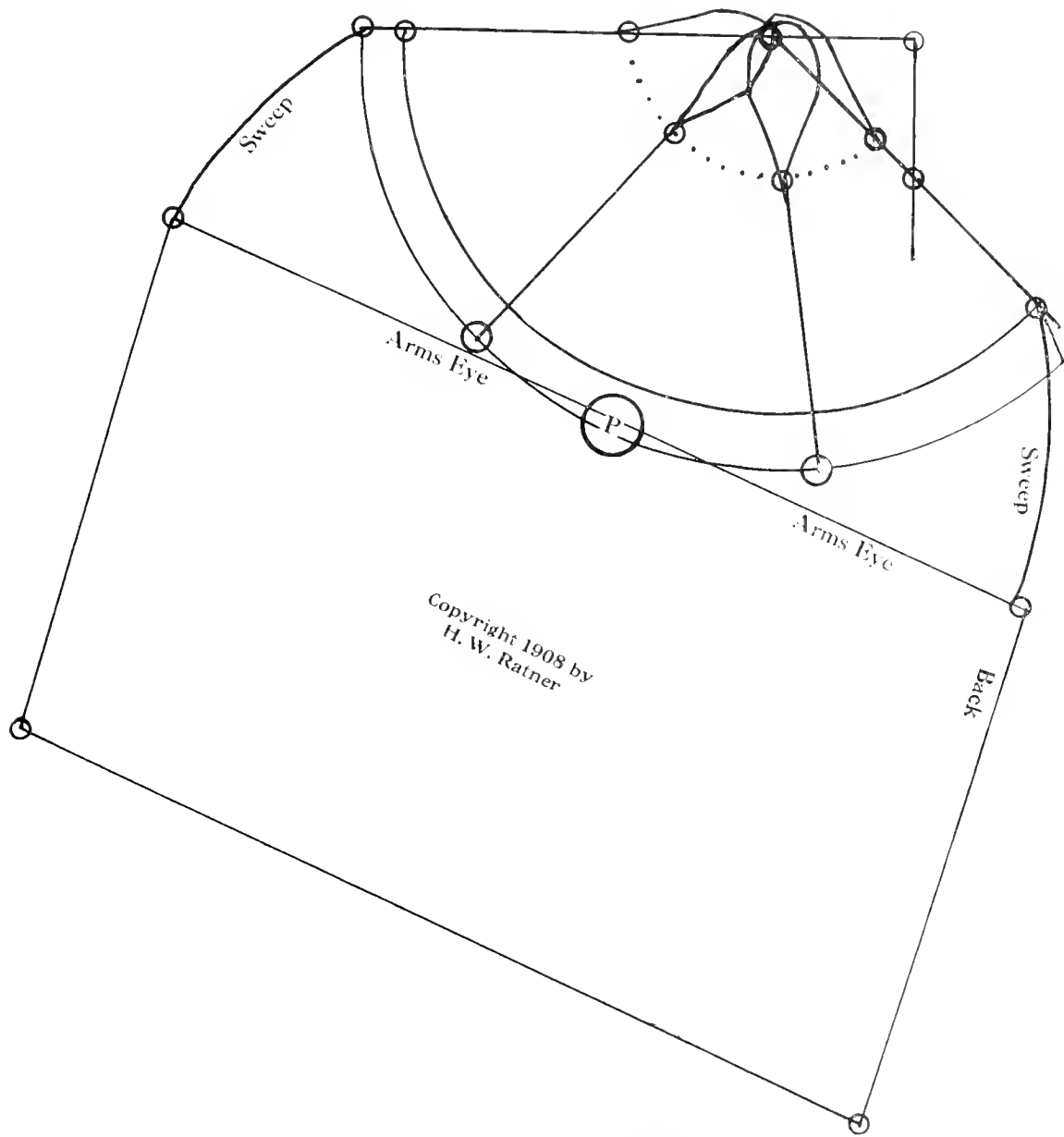
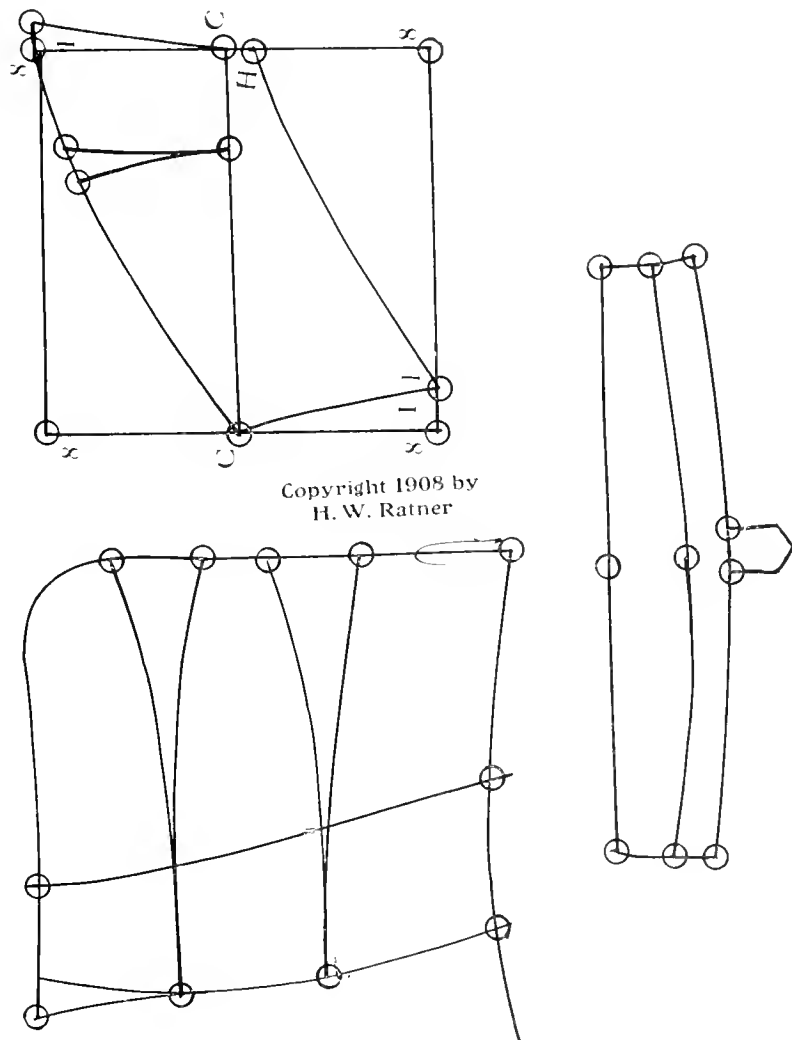

Diagram 45.

Ratner's Up-To-Date Method of Designing



Copyright 1908 by
H. W. Ratner

Diagram 46.

Ratner's Up-To-Date Method of Designing

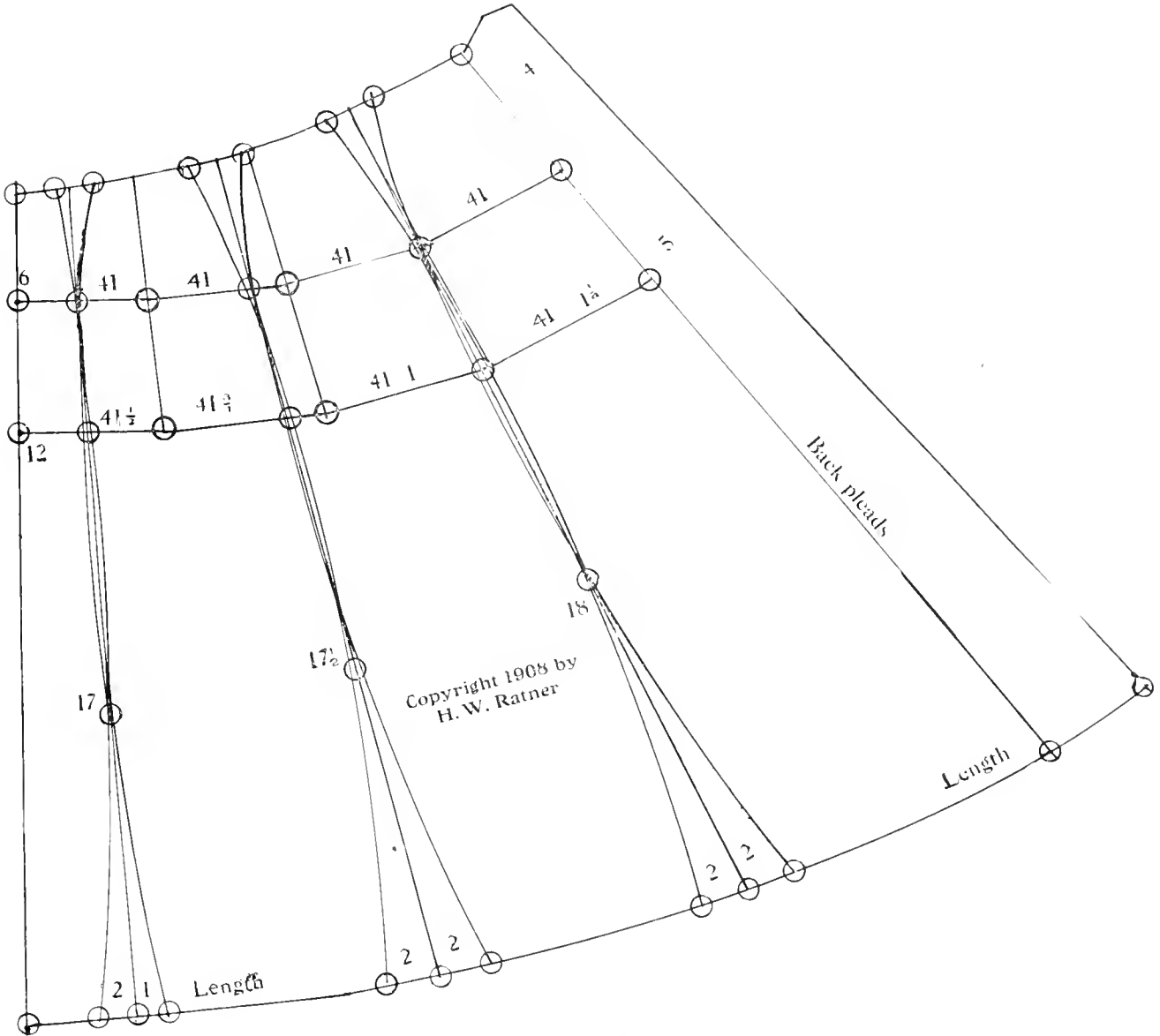

Diagram No. 47.



Ratner's Up-to-Date Method of Designing

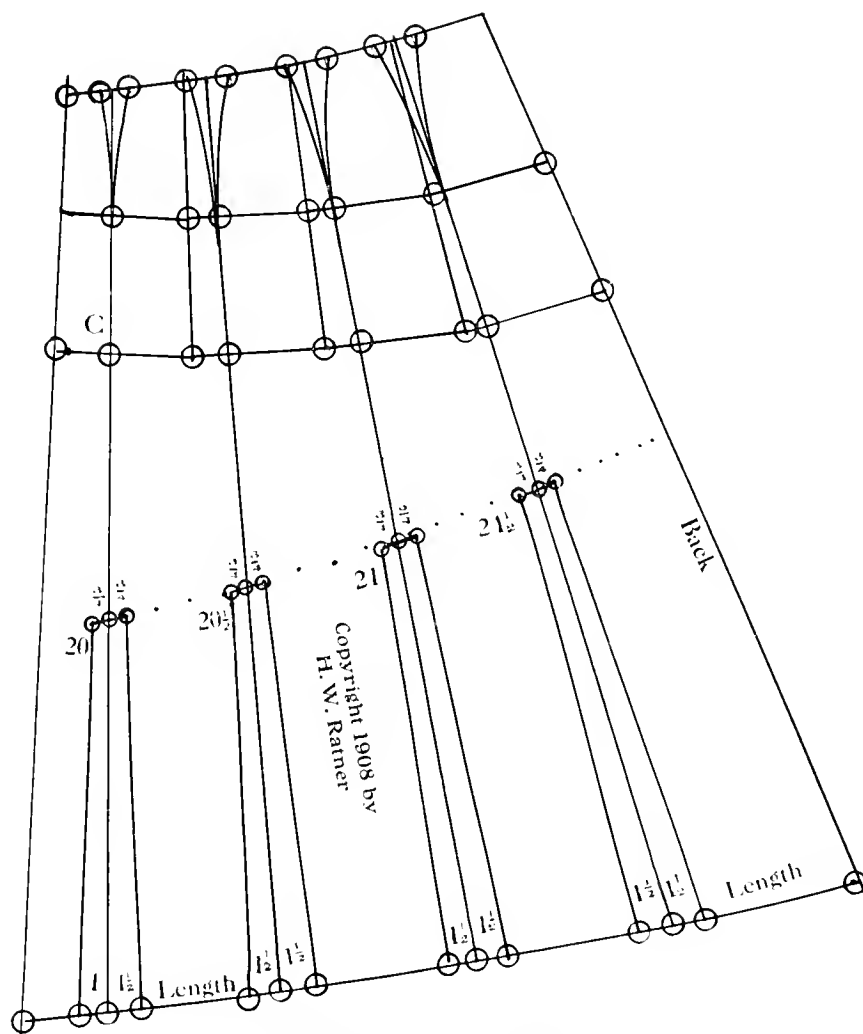

Diagram 48.

Ratner's Up-To-Date Method of Designing

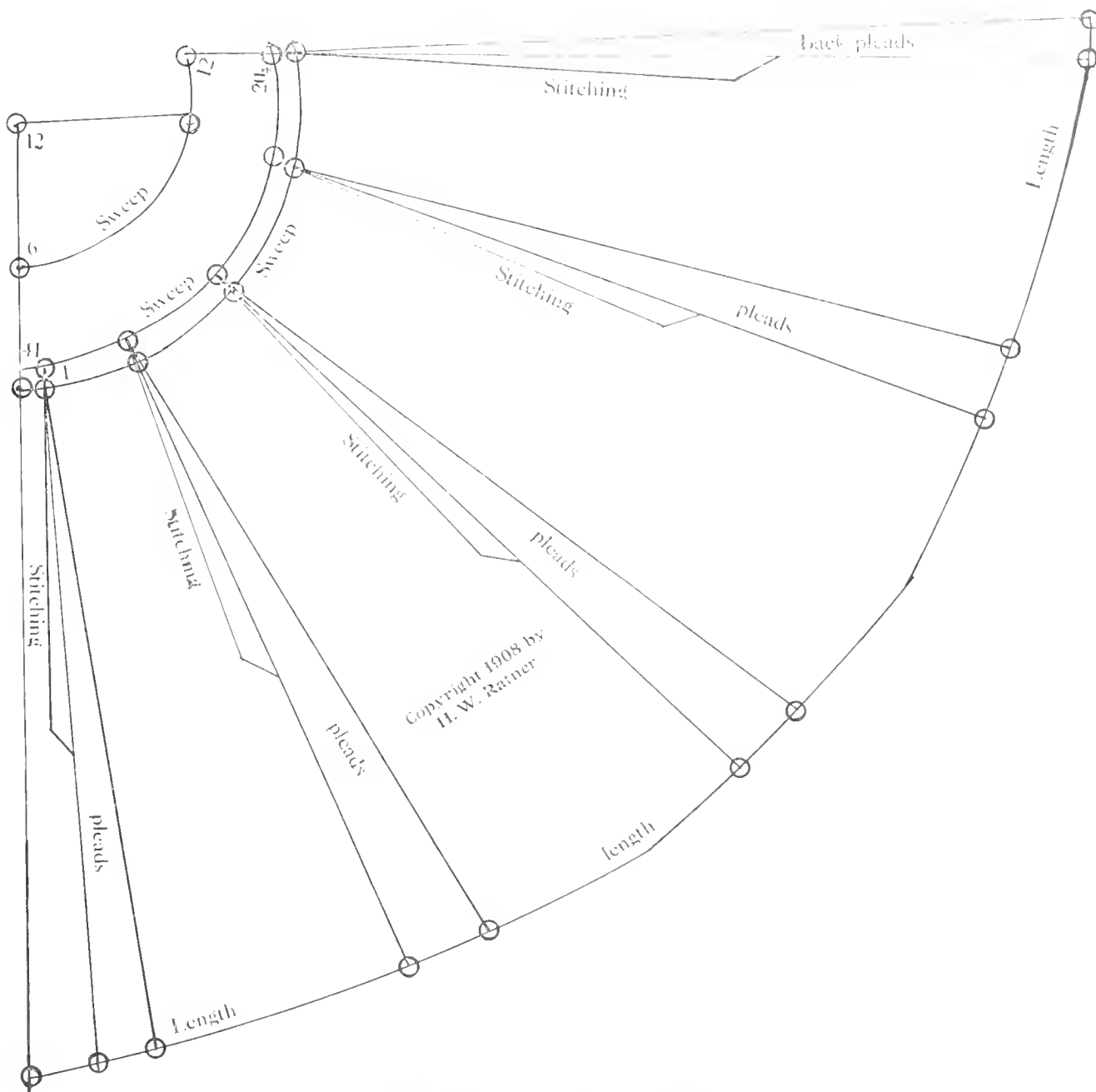

Diagram No. 49.

Ratner's Up-To-Date Method of Designing

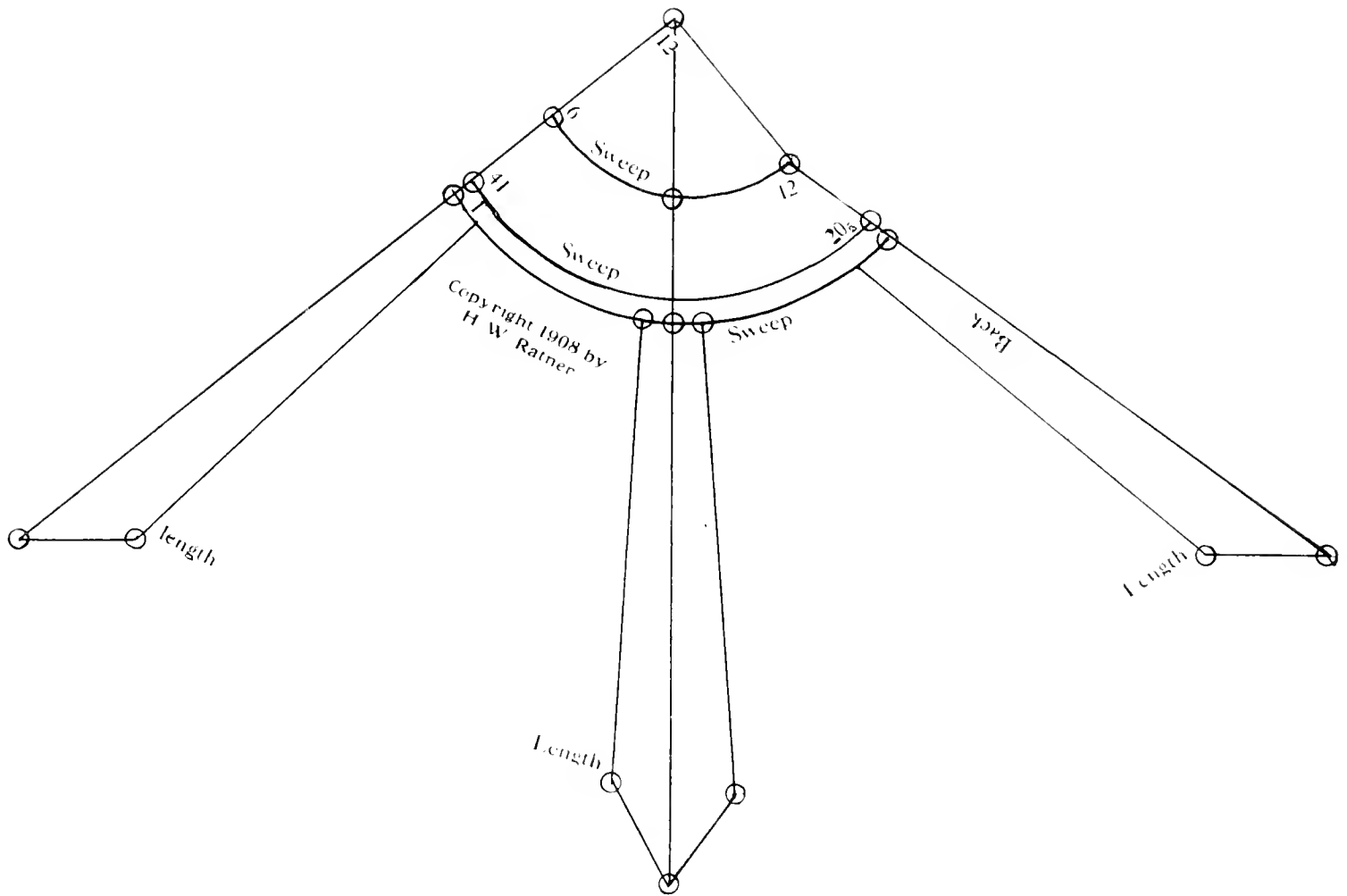

Diagram No. 50.

Ratner's Up-To-Date Method of Designing

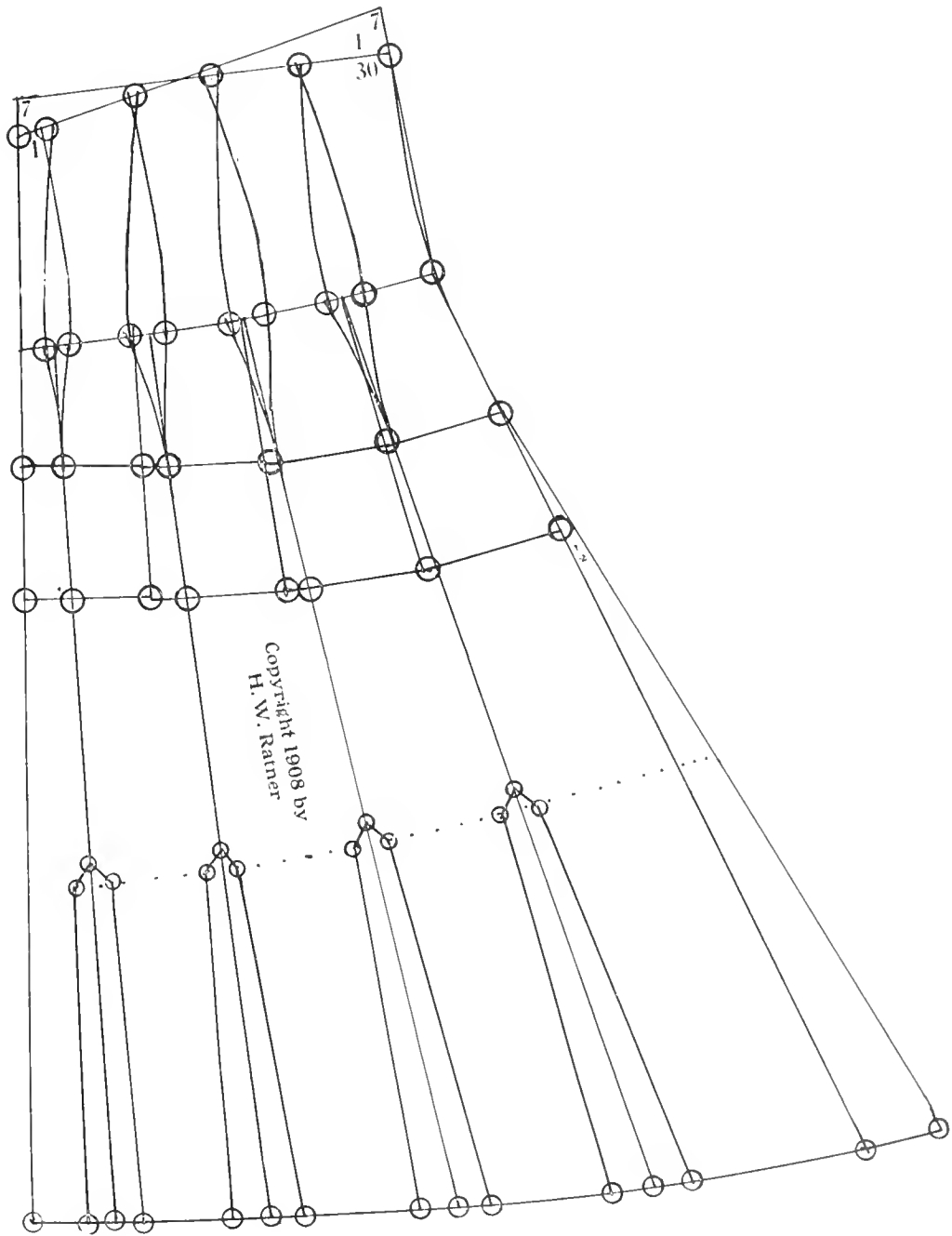

Diagram 51.

Ratner's Up-Co-Date Method of Designing

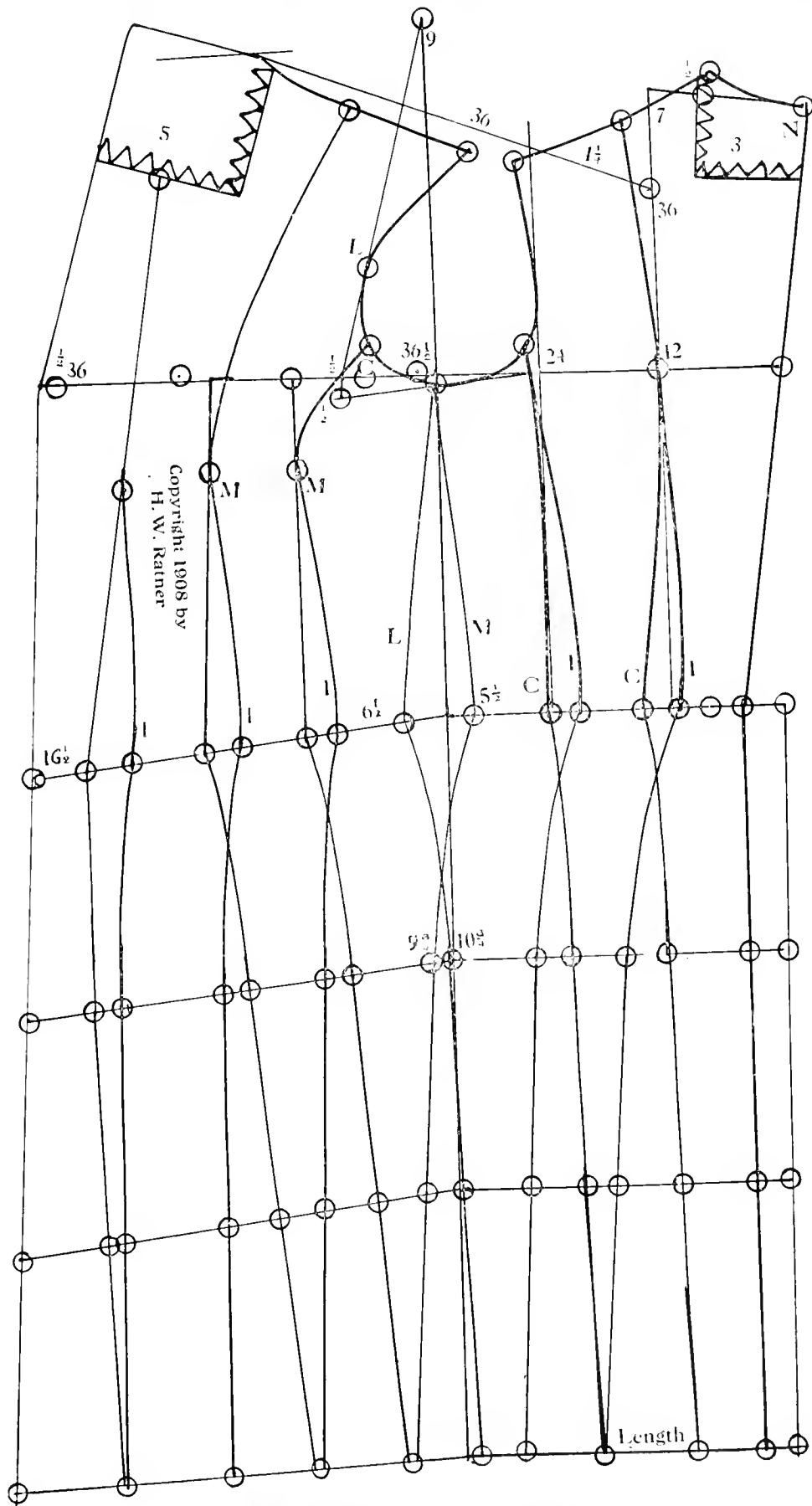

Diagram No. 52.

Ratner's Up-To-Date Method of Designing

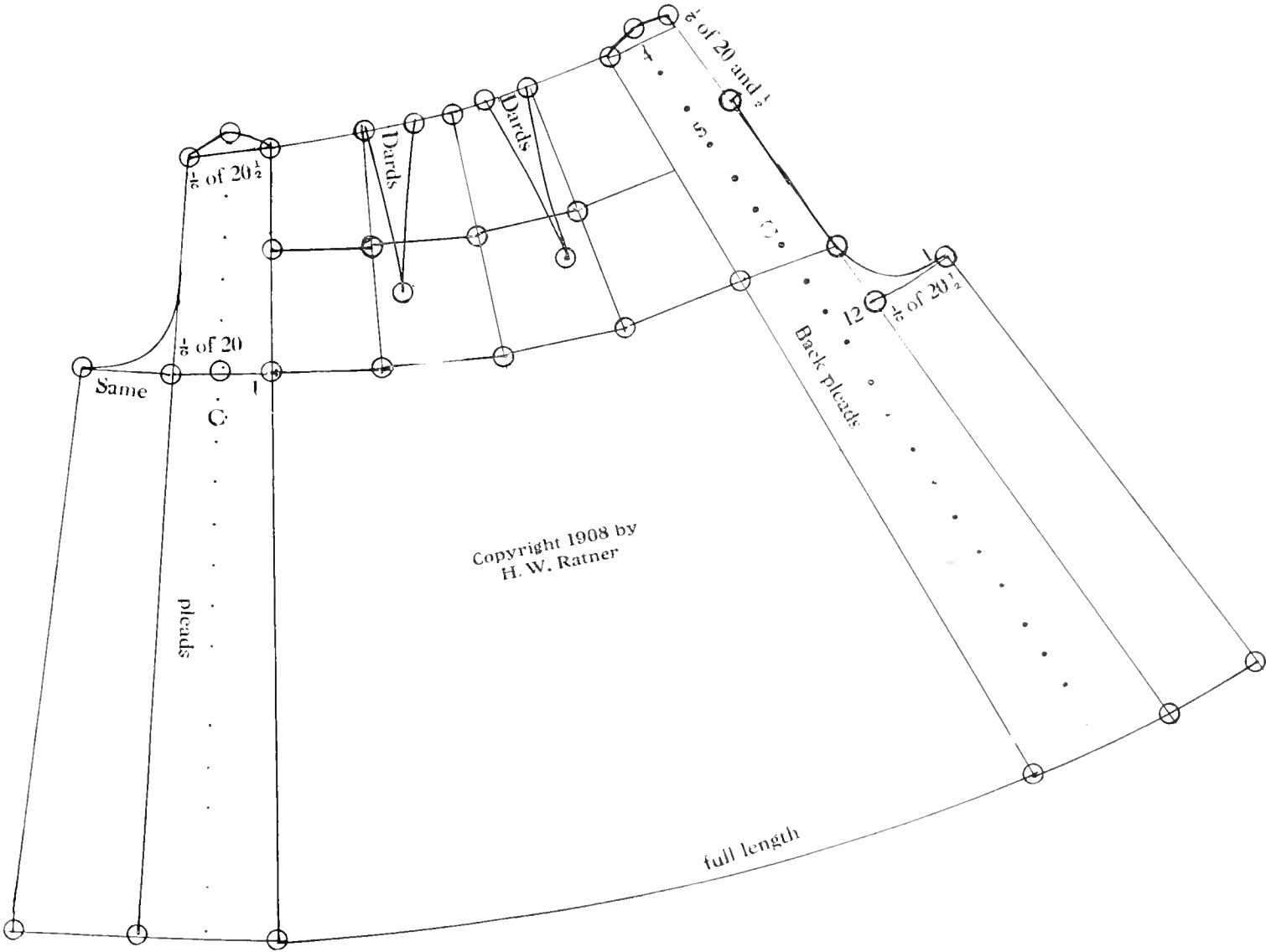

Diagram 53.

Ratner's Up-to-Date Method of Designing

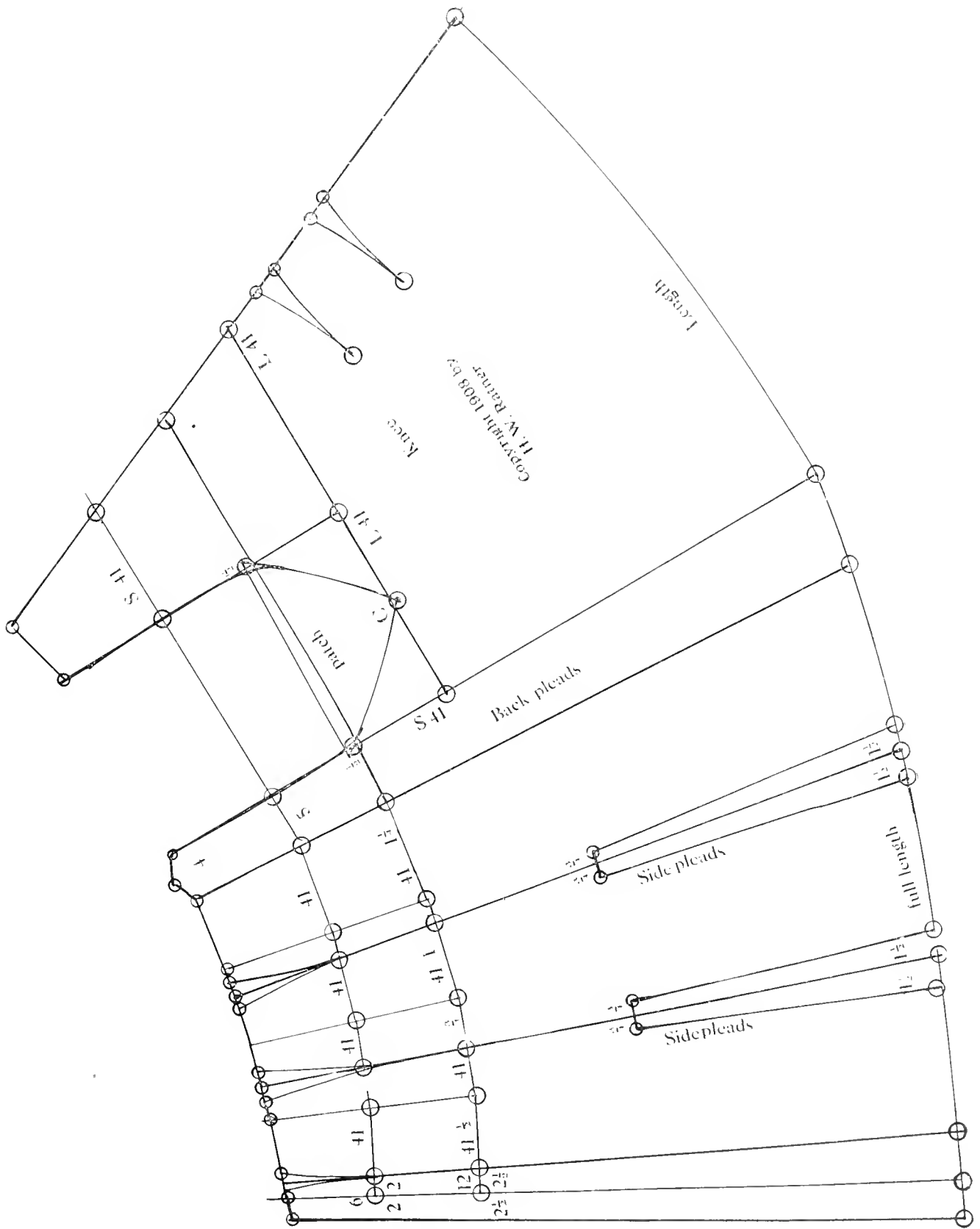

Diagram 54.

Ratner's Up-to-Date Method of Designing

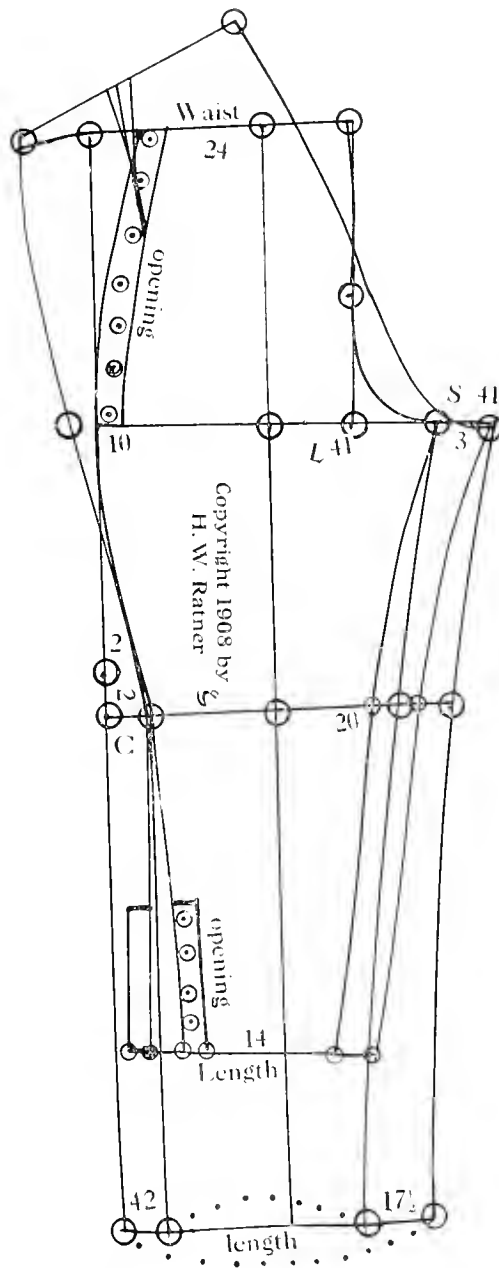

Diagram No. 55.

Ratner's Up-to-Date Method of Designing

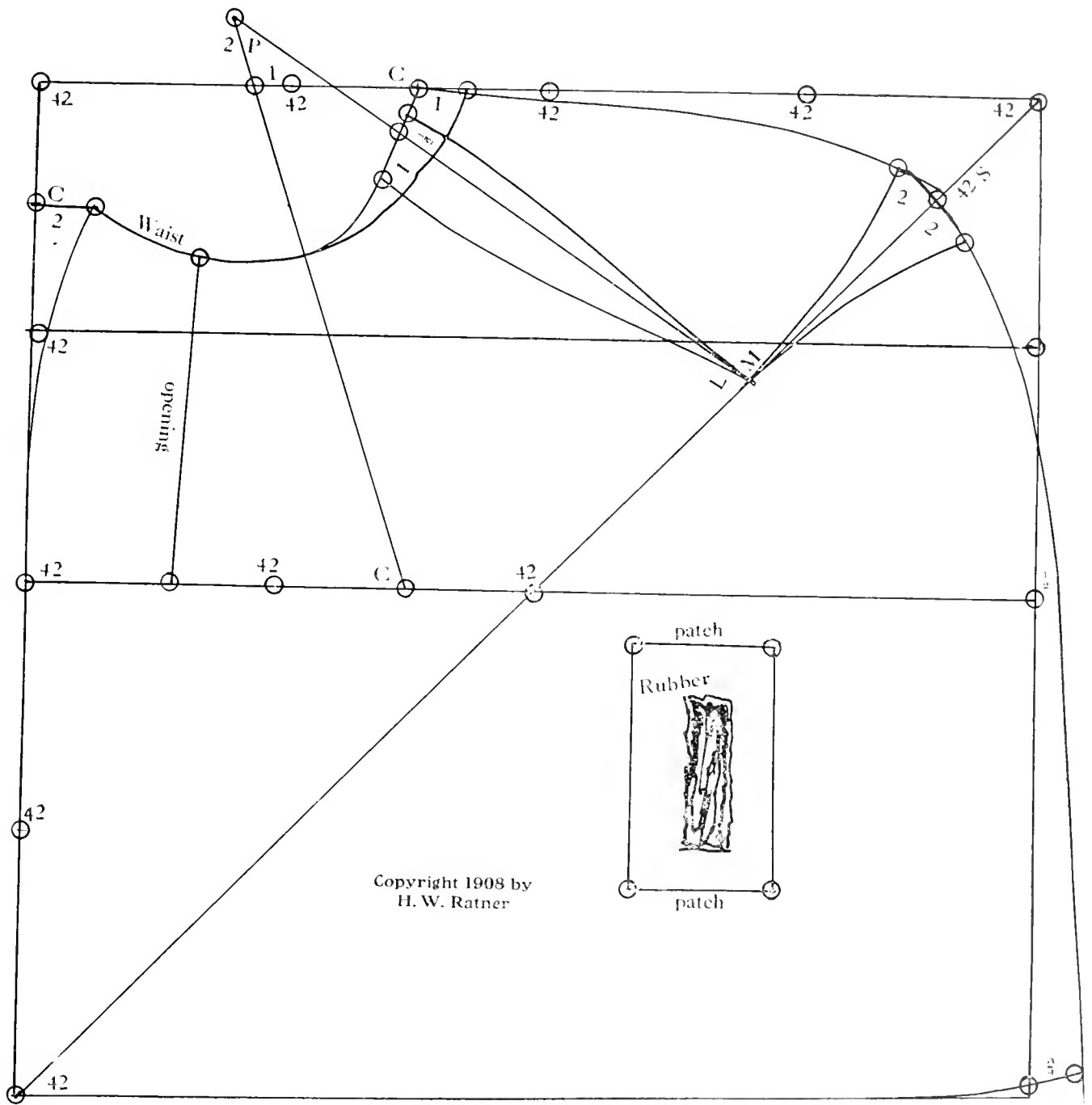

Diagram 56.

Ratner's Up-to-Date Method of Designing

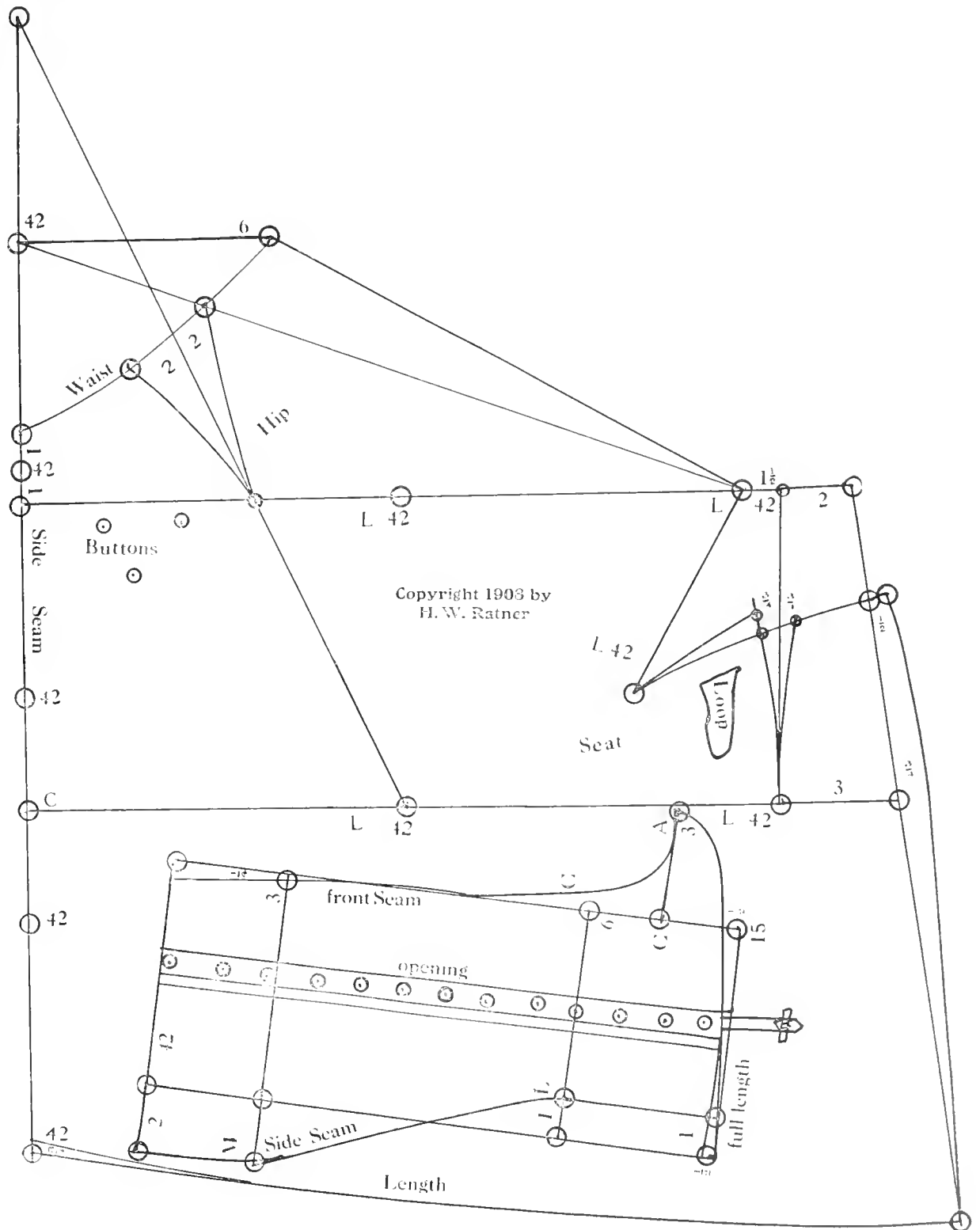

Diagram No. 57.

Ratner's Up-To-Date Method of Designing

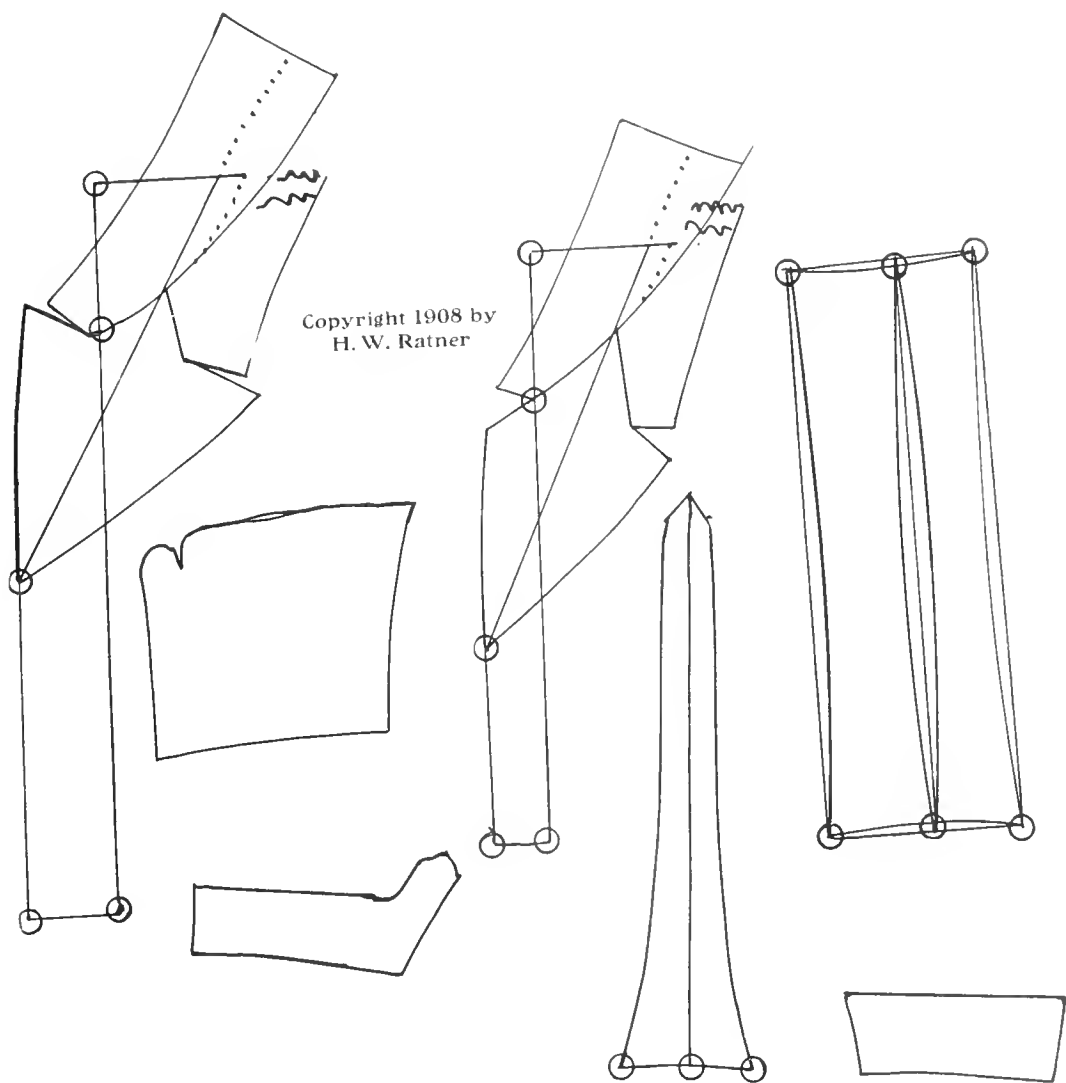

Diagram 58.

W. O. G.

Ratner's Up-to-Date Method of Designing

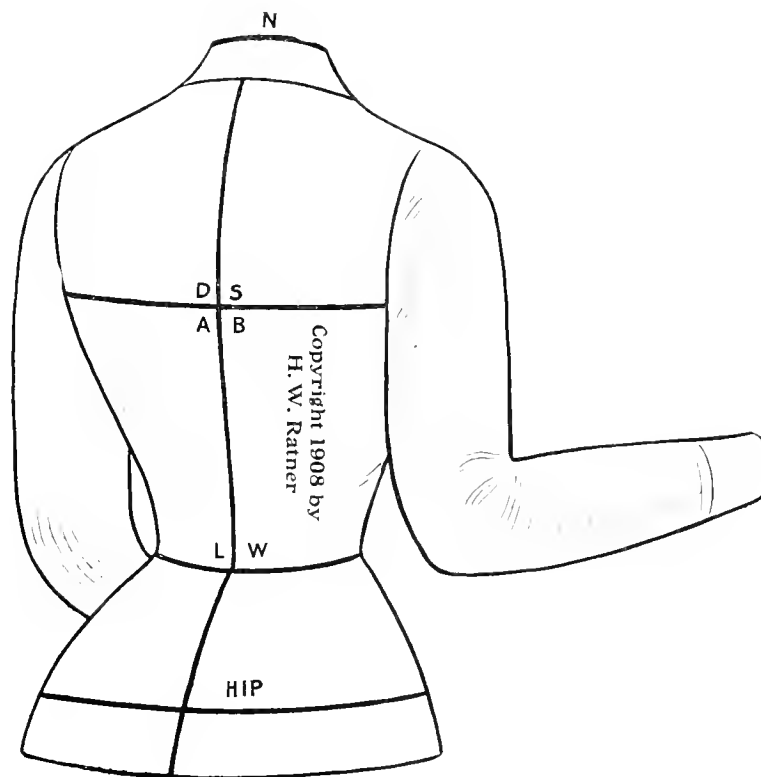

Diagram No. 59.

Ratner's Up-to-Date Method of Designing

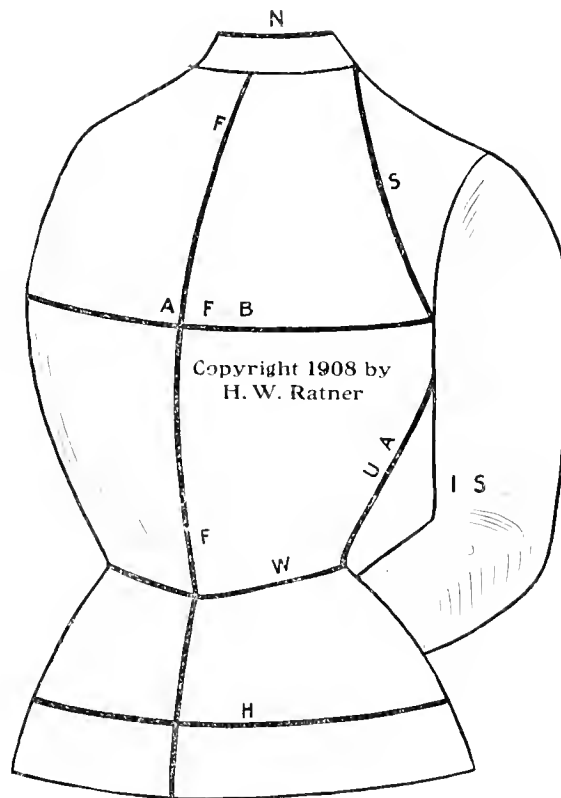

Diagram 60.

LIBRARY OF CONGRESS



0 013 973 145 1