

# Reanalysis of Wave Runup on Structures and Beaches

by  
Philip N. Stoa

TECHNICAL PAPER NO. 78-2  
MARCH 1978

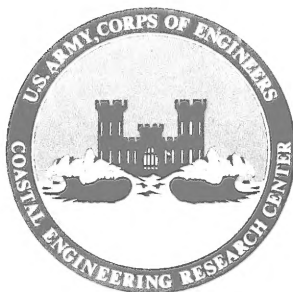

Approved for public release;  
distribution unlimited.

**U.S. ARMY, CORPS OF ENGINEERS  
COASTAL ENGINEERING  
RESEARCH CENTER**

Kingman Building  
Fort Belvoir, Va. 22060

GB  
458  
.TY  
no 78-2

Reprint or republication of any of this material shall give appropriate credit to the U.S. Army Coastal Engineering Research Center.

Limited free distribution within the United States of single copies of this publication has been made by this Center. Additional copies are available from:

Contents  
publication  
constitute  
commercial

The final  
Department  
authorized

Advertising,  
does not  
of such

official  
other

DEMCO



REPORT DOCUMENTATION PAGE		READ INSTRUCTIONS BEFORE COMPLETING FORM
1. REPORT NUMBER TP 78-2	2. GOVT ACCESSION NO.	3. RECIPIENT'S CATALOG NUMBER
4. TITLE (and Subtitle)  REANALYSIS OF WAVE RUNUP ON STRUCTURES AND BEACHES		5. TYPE OF REPORT & PERIOD COVERED  Technical Report
		6. PERFORMING ORG. REPORT NUMBER
7. AUTHOR(s)  Philip N. Stoa		8. CONTRACT OR GRANT NUMBER(s)
9. PERFORMING ORGANIZATION NAME AND ADDRESS Department of the Army Coastal Engineering Research Center (CEREN-CD) Kingman Building, Fort Belvoir, Virginia 22060		10. PROGRAM ELEMENT, PROJECT, TASK AREA & WORK UNIT NUMBERS  F31234
11. CONTROLLING OFFICE NAME AND ADDRESS Department of the Army Coastal Engineering Research Center Kingman Building, Fort Belvoir, Virginia 22060		12. REPORT DATE March 1978
		13. NUMBER OF PAGES 131
14. MONITORING AGENCY NAME & ADDRESS (if different from Controlling Office)		15. SECURITY CLASS. (of this report)  UNCLASSIFIED
		15a. DECLASSIFICATION/DOWNGRADING SCHEDULE
16. DISTRIBUTION STATEMENT (of this Report)  Approved for public release; distribution unlimited.		
17. DISTRIBUTION STATEMENT (of the abstract entered in Block 20, if different from Report)		
18. SUPPLEMENTARY NOTES		
19. KEY WORDS (Continue on reverse side if necessary and identify by block number)		
Breakwaters	Quarrystone	Runup
Coastal engineering	Revetments	Scale effects
Coastal structures	Riprap	Wave runup
Concrete armor units		
20. ABSTRACT (Continue on reverse side if necessary and identify by block number)		
<p>Published and unpublished results of tests of monochromatic wave runup were reanalyzed for both smooth and rough structure surfaces. The rough-surfaced structures included breakwaters and riprapped slopes, and both quarrystone and concrete armor units.</p> <p>Wave runup theory is discussed briefly and an empirical equation is given for runup on smooth slopes from waves which break on the structure slope.</p> <p style="text-align: right;">(continued)</p>		

Example problems and methods of data analysis, together with general observations, are given.

Smooth-slope runup results for both breaking and nonbreaking waves are presented in a set of curves similar to but revised from those in the Shore Protection Manual (SPM) (U.S. Army, Corps of Engineers, Coastal Engineering Research Center, 1977). The curves are for structure slopes fronted by horizontal and 1 on 10 bottom slopes. The range of values of  $d_g/H'_0$  was extended to  $d_g/H'_0 = 8$ ; relative depth ( $d_g/H'_0$ ) is important even for  $d_g/H'_0 > 3$  for waves which do not break on the structure slope. Rough-slope results are presented in similar curves if sufficient data were available. Otherwise, results are given as values of  $r$ , which is the ratio of rough-slope runup to smooth-slope runup.

Scale-effect in runup is discussed.

## PREFACE

This report is published to provide coastal engineers with an analysis of wave runup on structures and beaches. The report uses results from extensive literature on monochromatic wave testing. The method of data presentation in this study is consistent with that used in the Shore Protection Manual (SPM) (U.S. Army, Corps of Engineers, Coastal Engineering Research Center, 1977). The work was carried out under the coastal construction program of the U.S. Army, Coastal Engineering Research Center (CERC).

The report was prepared by Philip N. Stoa, Oceanographer, under the general supervision of R.A. Jachowski, Chief, Coastal Design Criteria Branch.

Comments on this report are invited.

Approved for publication in accordance with Public Law 166, 79th Congress, approved 31 July 1945, as supplemented by Public Law 172, 88th Congress, approved 7 November 1963.

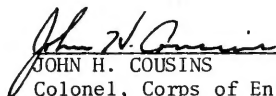

---

JOHN H. COUSINS

Colonel, Corps of Engineers  
Commander and Director

CONTENTS

	Page
CONVERSION FACTORS, U.S. CUSTOMARY TO METRIC (SI) . . . . .	10
SYMBOLS AND DEFINITIONS. . . . .	11
I INTRODUCTION . . . . .	13
II PROBLEM DEFINITION . . . . .	15
III THEORETICAL AND EMPIRICAL EQUATIONS . . . . .	18
1. General . . . . .	18
2. Example Problems . . . . .	26
IV QUALITATIVE ANALYSIS . . . . .	29
1. General . . . . .	29
2. Slope Roughness . . . . .	33
3. Effects of Beach Slope Fronting a Structure . . . . .	33
4. Breaking Waves . . . . .	35
5. Maximum Runup . . . . .	36
V EXPERIMENTAL RESULTS . . . . .	38
1. Smooth Slopes . . . . .	38
2. Rubble Slopes . . . . .	60
3. Stepped Slopes . . . . .	96
4. Estimation of Rough-Slope Runup . . . . .	100
VI SCALE EFFECTS . . . . .	103
1. General . . . . .	103
2. Reynolds Number . . . . .	104
3. Smooth-Slope Scale Effects . . . . .	106
4. Rough-Slope Scale Effects . . . . .	113
5. Example Problems . . . . .	118
VII RECOMMENDATIONS FOR FUTURE RESEARCH . . . . .	119
VIII SUMMARY. . . . .	121
LITERATURE CITED . . . . .	124
BIBLIOGRAPHY . . . . .	128

TABLES

1 Relative water depths . . . . .	15
2 Smooth-slope runup test conditions . . . . .	39

CONTENTS

TABLES--Continued

	Page
3 Example runup for $T = 7$ seconds, constant depth, and $(H'_0)_{max} = 5.0$ meters . . . . .	58
4 Example runup for $T = 13$ seconds, constant depth, and $(H'_0)_{max} = 5.0$ meters . . . . .	59
5 Example runup for constant wave steepness, $H'_0/gT^2 = 0.0104$ . . . . .	59
6 Summary of maximum runup for different conditions . . . . .	60
7 Quarystone rubble-mound runup test conditions . . . . .	63
8 Values of $r$ for a quarystone rubble mound . . . . .	73
9 Quarystone revetment runup tests . . . . .	74
10 Values of $r$ for quarystone riprap, 1 on 1.5 slope . . . . .	76
11 Summary of $r$ values . . . . .	87
12 Values of $r$ for quadripods on 1 on 1.5 slope . . . . .	89
13 Values of $r$ for tribars and quarystone on a 1 on 3 slope . . . . .	90
14 Summary of $r$ values for structures fronted by a horizontal bottom . . . . .	92
15 Values of $r$ for one layer of tribars on 1 on 3 slope with tribars underlain by two filter layers . . . . .	93
16 Ratios of stepped-slope runup to smooth-slope runup; 1 on 1.5 structure slope; 1 on 10 bottom slope; $d_g > 0$ . . . . .	97
17 Ratios of stepped-slope runup to smooth-slope runup; 1 on 1.5 structure slope; 1 on 10 bottom slope; $d_g = 0$ . . . . .	97
18 Ratios of stepped-slope runup to smooth-slope runup . . . . .	101
19 Reynolds numbers for three different depths . . . . .	105
20 Comparison of smooth-slope runup between small and large scales for 1 on 3 and 1 on 6 structure slopes with 1 on 10 beach slope . . . . .	108

## CONTENTS

### TABLES--Continued

		Page
21	Large-scale tests of runup on smooth slope roughened with one layer of 0.4-millimeter sand; 1 on 3 structure slope . . .	110
22	Scale effects for quarystone rubble mound with core much below SWL . . . . .	115
23	Scale effects for quadripod rubble mound . . . . .	116

### FIGURES

1	Mean monthly nearshore wave periods (including calms) for five coastal segments . . . . .	14
2	Definition sketch of variables applicable to wave runup . . . .	16
3	Example of runup data plotted to show trends of lines of $d_s/gT^2$ and the line of complete breaking . . . . .	21
4	Empirical curves of minimum wave steepness for complete wave breaking at a specified smooth slope and relative depth . . . .	22
5	Values of $q$ for equation (8) . . . . .	24
6	Flow chart for runup on smooth structure slope fronted by horizontal bottom . . . . .	25
7	Conceptual sketch of runup data for constant values of $d_s/gT^2$ and for a fixed slope . . . . .	31
8	Sketch of lines of $d_s/H'_O$ related to lines of $d_s/gT^2$ for a fixed slope . . . . .	31
9	Relative runup comparisons between smooth slopes and permeable rubble-mound slopes; $d_s/H'_O > 3.0$ . . . . .	32
10	Schematic trends of $d_s/H'_O$ for steep slopes on a sloping beach . . . . .	32
11	Regions of breaking waves for depth-related instabilities . . .	35
12	Sample lines of constant $d_s/gT^2$ for runup on structures on sloping and flat beaches . . . . .	36
13	Conditions for wave breaking on beach slope in front of structure . . . . .	37



CONTENTS

FIGURES--Continued

		Page
14	Relative runup for smooth slopes on horizontal bottom; $d_g/H'_0 = 3.0$ . . . . .	42
15	Relative runup for smooth slopes on horizontal bottom; $d_g/H'_0 = 5.0$ . . . . .	43
16	Relative runup for smooth slopes on horizontal bottom; $d_g/H'_0 = 8.0$ . . . . .	44
17	Relative runup for smooth slopes on 1 on 10 beach; $d_g = 0$ ; $d/H'_0 = 3.0$ . . . . .	45
18	Relative runup for smooth slopes on 1 on 10 beach; $d_g = 0$ ; $d/H'_0 = 5.0$ . . . . .	46
19	Relative runup for smooth slopes on 1 on 10 beach; $d_g = 0$ ; $d/H'_0 = 8.0$ . . . . .	47
20	Relative runup for smooth slopes on 1 on 10 beach; $\ell/L \geq 0.5$ ; $d_g/H'_0 = 0.6$ . . . . .	48
21	Relative runup for smooth slopes on 1 on 10 beach; $\ell/L \geq 0.5$ ; $d_g/H'_0 = 1.0$ . . . . .	49
22	Relative runup for smooth slopes on 1 on 10 beach; $\ell/L \geq 0.5$ ; $d_g/H'_0 = 1.5$ . . . . .	50
23	Relative runup for smooth slopes on 1 on 10 beach; $\ell/L \geq 0.5$ ; $d_g/H'_0 = 3.0$ . . . . .	51
24	Permeable rubble-mound structures . . . . .	62
25	Quarrystone rubble-mound runup; $d_g/H'_0 = 3.0$ ; $H'_0/k_T = 4.5$ ; $h_c/d_g \approx 0.75$ . . . . .	64
26	Quarrystone rubble-mound runup; $d_g/H'_0 = 5.0$ ; $H'_0/k_T = 2.7$ ; $h_c/d_g \approx 0.75$ . . . . .	65
27	Quarrystone rubble-mound runup; $d_g/H'_0 = 8.0$ ; $H'_0/k_T = 1.7$ ; $h_c/d_g \approx 0.75$ . . . . .	66
28	Quarrystone rubble-mound runup ("smooth" stones); random placement; $d_g/H'_0 = 5.0$ ; $H'_0/k_T = 2.7$ ; $h_c/d_g \approx 1.10$ . . . . .	67
29	Runup on rubble slope; $d_g/H'_0 = 3.0$ ; $H'_0/k_T = 12.7$ . . . . .	69
30	Runup on rubble slope; $d_g/H'_0 = 8.0$ ; $H'_0/k_T = 4.8$ . . . . .	70

CONTENTS

FIGURES--Continued

	Page
31 Values of $r$ for slope and relative roughness ( $H'_o/k_p$ ) for permeable rubble mound . . . . .	71
32 Values of $r$ for slope and relative roughness ( $H'_o/k_p$ ) for permeable structure . . . . .	72
33 Impermeable structures . . . . .	75
34 Runup for riprap slopes, approximately two layers . . . . .	77
35 Values of $r$ for slope and relative roughness ( $H'_o/k_p$ ) for riprap slopes; armor layer approximately two stones thick . . . . .	78
36 Runup curves for 1 on 1.5 riprap slope fronted by 1 on 50 bottom slope . . . . .	79
37 Relative runup for 1 on 2 riprap slope fronted by 1 on 200 slope . . . . .	81
38 Values of $r$ for relative roughness ( $H'_o/k_p$ ), for 1 on 2 riprap slope fronted by 1 on 200 slope . . . . .	82
39 Example of runup for 1 on 3.5 riprap slope, $d_s/H'_o = 7.0$ , for various relative stone sizes . . . . .	83
40 Relative runup for riprap slopes, $d_s/H'_o = 5.0$ , $H'_o/k_p \approx 3.15$ . . . . .	84
41 Relative runup for riprap slopes, $d_s/H'_o = 8.0$ , $H'_o/k_p = 2.8$ . . . . .	85
42 Values of $r$ for riprap slope and relative roughness ( $H'_o/k_p$ ) . . . . .	86
43 Concrete armor units tested by Jackson (1968a) . . . . .	88
44 Gobi blocks . . . . .	93
45 Stepped-slope runup; $d_s \neq 0$ ; 1 on 1.5 structure slope; 1 on 10 bottom slope . . . . .	98
46 Stepped-slope runup; $d_s = 0$ ; 1 on 1.5 structure slope; 1 on 10 bottom slope . . . . .	99
47 Hypothetical sketch of relative runup variations (scale effects) on a given structure for sets of specified wave conditions and varying Reynolds number . . . . .	106

CONTENTS

FIGURES--Continued

	Page
48 Scale effects on smooth-slope runup as function of Reynolds number; $d_s/H_O^1 = 1.5$ ; 1 on 3 and 1 on 6 structure slopes; 1 on 10 bottom slope . . . . .	107
49 Correction factor, $k$ , for scale effects in runup on smooth slopes, $\cot \theta > 1.25$ . . . . .	112
50 Runup scale-effect correction factor, $k$ , replotted from Figure 49 and extrapolated for all smooth slopes . . . . .	114

CONVERSION FACTORS, U.S. CUSTOMARY TO METRIC (SI)  
UNITS OF MEASUREMENT

U.S. customary units of measurement used in this report can be converted to metric (SI) units as follows:

Multiply	by	To obtain
inches	25.4	millimeters
	2.54	centimeters
square inches	6.452	square centimeters
cubic inches	16.39	cubic centimeters
feet	30.48	centimeters
	0.3048	meters
square feet	0.0929	square meters
cubic feet	0.0283	cubic meters
yards	0.9144	meters
square yards	0.836	square meters
cubic yards	0.7646	cubic meters
miles	1.6093	kilometers
square miles	259.0	hectares
knots	1.8532	kilometers per hour
acres	0.4047	hectares
foot-pounds	1.3558	newton meters
millibars	$1.0197 \times 10^{-3}$	kilograms per square centimeter
ounces	28.35	grams
pounds	453.6	grams
	0.4536	kilograms
ton, long	1.0160	metric tons
ton, short	0.9072	metric tons
degrees (angle)	0.1745	radians
Fahrenheit degrees	5/9	Celsius degrees or Kelvins <sup>1</sup>

<sup>1</sup>To obtain Celsius (C) temperature readings from Fahrenheit (F) readings, use formula:  $C = (5/9) (F - 32)$ .

To obtain Kelvin (K) readings, use formula:  $K = (5/9) (F - 32) + 273.15$ .

## SYMBOLS AND DEFINITIONS

$d$	water depth
$d_s$	water depth at toe of structure
$g$	acceleration of gravity
$H$	wave height
$H_{D=0}$	zero damage wave height
$H'_0$	unrefracted deepwater wave height; $H'_0$ is the deepwater equivalent of the wave height, $H$ , measured in a given water depth; $H$ is related to $H'_0$ by the shoaling coefficient, $H/H'_0$
$h_c$	height of core above toe of rubble-mound structure
$K_s$	shoaling coefficient
$k$	runup correction factor for scale effect
$k_p$	roughness dimension, expressed as an armor unit length
$L$	wavelength in a water depth, $d$
$L_0$	deepwater wavelength; wavelength in water of depth, $d$ , where $d/L \geq 0.5$
$\ell$	horizontal length of slope (beach slope) fronting toe of structure
$q$	empirical exponent used in runup equation
$R$	runup; the vertical rise of water on structure face resulting from wave action
$R_e$	Reynolds number
$r$	ratio of rough-slope runup to smooth-slope runup; rough-slope runup correction factor
$T$	wave period
$W$	armor stone weight
$\beta$	beach slope, used for slope fronting a structure; different from structure slope
$\theta$	structure slope
$\nu$	kinematic viscosity



# REANALYSIS OF WAVE RUNUP ON STRUCTURES AND BEACHES

by  
*Philip N. Stoa*

## I. INTRODUCTION

Wave runup, or simply runup, is an important aspect of the interaction of waves and coastal structures. *Runup* is the height above still-water level (SWL) to which a wave will rise on a structure or beach, and is analyzed in dimensionless parameters. The runup divided by the wave height is commonly defined as *relative runup*.

Summaries of previously published studies on wave runup, using various methods of data presentation, were reported in Koh and Le Mehaute (1966); van Dorn (1966); van Dorn, Le Mehaute, and Hwang (1968); Webber and Bullock (1970); Technical Advisory Committee on Protection Against Inundation (1974); and Raichlen (1975). The presentation of data in this study is consistent with that used in the Shore Protection Manual (SPM) (U.S. Army, Corps of Engineers, Coastal Engineering Research Center, 1977).

Only short-period waves, which are of primary interest to coastal engineers, were considered for this study, although long-period waves such as tsunamis are under extensive study. Wind waves are the major component of the short-period wave group, but other waves such as ship-generated waves are also of interest. An arbitrary definition for short-period waves is that wave periods are less than 20 seconds (Le Mehaute, Koh, and Hwang, 1968). The SPM gives mean periods for visual observations on the U.S. coasts (Fig. 1), and the periods fall well within this classification.

Monochromatic waves are approximated by nature usually during periods when swell is predominant at the shore. Structural design is usually influenced (or determined) by storm conditions, including a confused sea of irregular waves. Although several reports have discussed this problem, it is not yet clear how to fully evaluate the runup produced by irregular waves. Current development of programable wave generators and improved methods for data acquisition will facilitate future analysis of irregular waves and runup.

This report uses the results from extensive literature on monochromatic wave testing, which covers a wide range of variables (i.e., structure types, structure slopes, beach slopes, etc.). Section II discusses the dimensional analysis; Section III discusses empirical equations for breaking wave runup, and includes a flow chart defining the limits for use of various solutions of runup on smooth slopes. Experimental data are also presented for smooth slopes in the form of empirical curves based on a reanalysis of smooth-slope runup data. Rough-slope runup is subsequently developed with emphasis on use of quarrystone and precast-concrete armor units. The rough-slope runup is given, where practical,

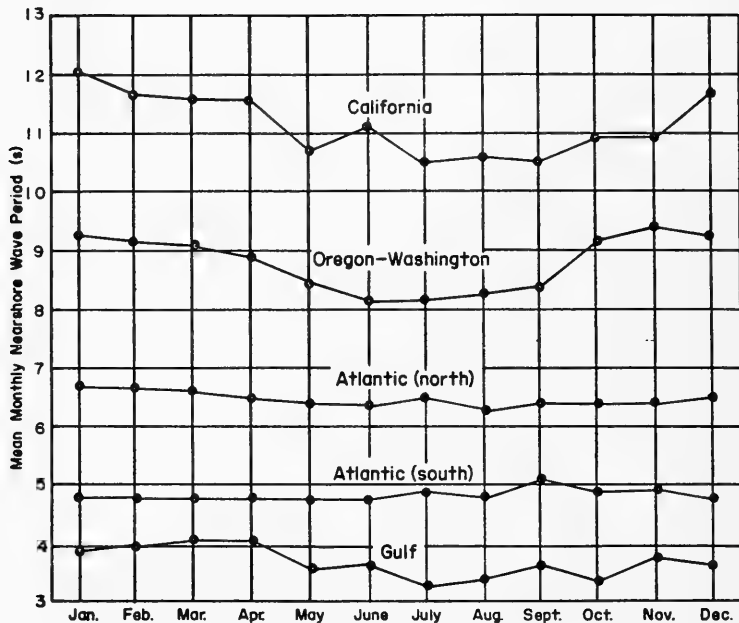

Figure 1. Mean monthly nearshore wave periods (including calms) for five coastal segments (U.S. Army, Corps of Engineers, Coastal Engineering Research Center, 1977).



as relative runup,  $R/H_0^1$ , but is also given as a ratio of rough-slope runup to smooth-slope runup for a particular structure type and slope. Scale effects are reviewed using Reynolds numbers, but only a limited number of large-scale tests are available. Consequently, a single scale-correction curve is given for smooth slopes; scale-effect corrections for rough slopes are discussed, and correction values are given.

## II. PROBLEM DEFINITION

Extensive theoretical and laboratory work has been reported for regular waves--waves which are long crested and periodic in time. Figure 2 is a definition sketch of the important dimensions for describing runup tests.

The wave is defined by its height,  $H$ , and length,  $L$ , in water of given depth,  $d$ . Wavelength is a function of period,  $T$ , and depth, where

$$L = L_0 \tanh\left(\frac{2\pi d}{L}\right) = \left(\frac{gT^2}{2\pi}\right) \tanh\left(\frac{2\pi d}{L}\right). \quad (1)$$

$L_0$  is the deepwater wavelength, where deep water is defined as  $d \geq 0.5L$  (Table 1; Fig. 2). Deep water may or may not exist for a given experiment or field problem; however, deepwater values can be calculated. Deepwater variables are preferred because of the general applicability of results and because the deepwater wavelength is then only a function of period. The use of deepwater variables is particularly applicable to problems involving sloping beaches, because the difficulty in describing varying wavelengths on sloping bottoms is avoided.

Table 1. Relative water depths.

	Shallow water	Transitional water	Deep water
$d/L$	<0.04	0.04 to 0.5	>0.5
$d/gT^2$	<0.00155	0.00155 to 0.0793	>0.0793

Wave height is also a function of water depth, and in a given depth is related to the deepwater wave height by a shoaling coefficient,  $K_s$ ; linear theory gives the expression

$$K_s = \frac{H}{H_0} = \sqrt{\frac{1}{\tanh(2\pi d/L)} \cdot \frac{1}{\left[1 + \left\{\frac{(4\pi d/L)}{\sinh(4\pi d/L)}\right\}\right]}}, \quad (2)$$

where  $H_0$  is the unrefracted equivalent deepwater wave height of a wave approaching the shoreline, and  $d$ ,  $L$ , and  $H$  are the shallow-water values at the depth of interest. The shoaling coefficient is derived from theory for waves in water of constant depth,  $d$ , but the relationship is commonly applied to coastal areas with variable depths.

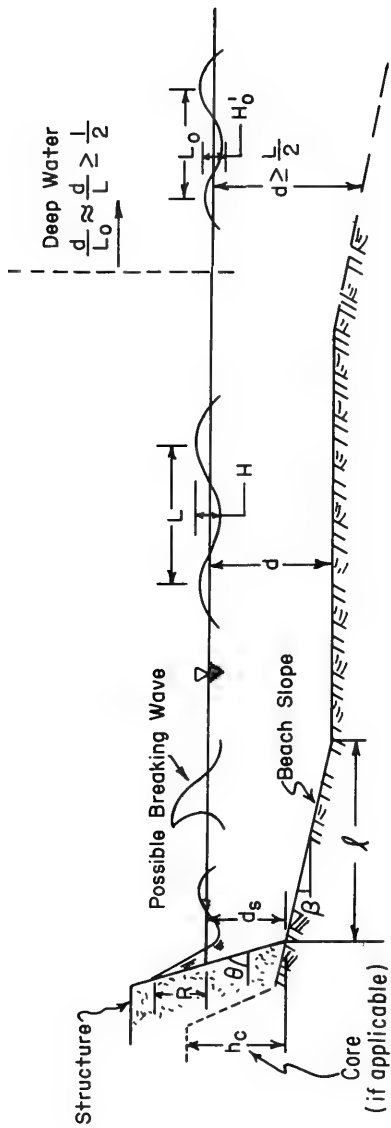

Figure 2. Definition sketch of variables applicable to wave runoff.

Except for extremely small  $d/L$  values or for waves near breaking, equation (2) approximates the shoaling coefficient for waves traversing gentle bottom slopes. Most laboratory experiments have used structures fronted by uniform water depths (formed by the tank floor). In other experiments with slopes fronting the structures, the wave height usually was measured in the uniform water depth of the flat part of the wave tank. In both situations the transformation of the wave height from measured height to deepwater height is particularly applicable using the linear theory shoaling coefficient (eq. 2) because of the relatively large tank depth in most cases. Some researchers use the wave height,  $H_s$ , at a given depth (usually the structure toe) to define relative runup. The drawback in using this approach to describe wave height is that on sloping beaches the wave may break before reaching the toe of the structure, and the resulting broken wave is not easily related to the nonbreaking wave characteristics.

Data were compiled for regular waves and uniform structure slopes according to the variables  $d_s$ ,  $H'_0$ ,  $h_c$ ,  $k_r$ ,  $\ell$ ,  $R$ ,  $T$ ,  $\beta$ ,  $\theta$ ,  $\nu$ , and  $g$ , from which the following dimensionless variables were derived:

$$\frac{H'_0}{gT^2} \quad \text{wave steepness}$$

$$\frac{d_s}{H'_0} \quad \text{relative depth at structure}$$

$$\frac{R}{H'_0} \quad \text{relative runup}$$

$$\theta \quad \text{structure slope}$$

$$\beta \quad \text{beach slope}$$

$$\frac{H'_0}{k_r} \quad \text{relative roughness}$$

$$\frac{\sqrt{gd_s}d_s}{\nu} \quad \text{depth Reynolds number, } R_e$$

$$\frac{\ell}{gT^2} \quad \text{relative horizontal length of beach slope}$$

$$\frac{h_c}{d_s} \quad \text{relative core height}$$

The roughness value,  $k_p$ , is used in describing roughness elements on a slope. For stone,  $k_p$  is the equivalent spherical diameter, based on the weight and density of the armor unit; for a concrete armor unit,  $k_p$  is defined specifically as a characteristic dimension of that armor unit. Because effects of porosity and roughness are difficult to differentiate, various structure types and cross sections are analyzed independently, with notation describing the structure characteristics (e.g., filter layers, if any; thickness of armor layer; height of core).

One of the above dimensionless variables is reformulated and, together with the other dimensionless variables, gives the following principal variables used:

$$\frac{R}{H'_0} = f\left(\frac{H'_0}{gT^2}, \frac{d_s}{H'_0}, \theta, \beta, \frac{H'_0}{k_p}, Re, \frac{\ell}{L}, \frac{h_c}{d_s}\right), \quad (3)$$

where  $Re$  is the depth Reynolds number (discussed in Sec. VI,2). The term  $\ell/L$  is used, rather than  $\ell/gT^2$ , because it was assumed that if the wavelength in the flat part of the tank is  $L \leq 2\ell$ , the relative runoff would be a function of a wave substantially influenced by the beach slope, and the relative beach-slope length,  $\ell/L$ , could be neglected. Some experiments had wavelengths much longer than the slope length (up to  $L \approx 5\ell$ ). For such conditions, in which  $L > 2\ell$ , relative runoff is expected to be a function, in part, of  $\ell/L$ . This beach-slope effect is discussed further in Section IV,3.

The term  $d_s/H'_0$  (relative depth) is used for consistency with the SPM. However, it is useful in that for each value of  $d_s/H'_0$ , the relative roughness term,  $H'_0/k_p$ , also has a constant value for a given absolute armor unit dimension and depth. An alternate form of relative depth,  $d_s/gT^2$ , is used occasionally, but principally as a means of deriving  $d_s/H'_0$  (see Sec. IV).

### III. THEORETICAL AND EMPIRICAL EQUATIONS

#### 1. General.

Theories dealing with wave runoff at the shoreline are applicable to either breaking or nonbreaking waves, but usually not both types. In this classification, waves break because of instability caused by decreasing depths instead of instability related to waves of maximum steepness in a uniform water depth. Various breaking criteria have been developed; a detailed discussion is given in Technical Advisory Committee on Protection Against Inundation (1974). Most nonbreaking wave theories are derived for rather long waves on very gentle, uniform slopes extending to an "infinite" depth. Breaking wave theories generally are concerned with a bore-type propagation on gentle slopes, rather than the plunging or spilling types commonly encountered on structures or steep beaches. Breaking waves are discussed here as related to structures in the coastal zone.

Miche (1951) developed breaking criteria for smooth uniform slopes extending to deep water. All waves incident to the slope would then be considered deepwater waves. His condition for breaking waves is

$$\frac{H'_0}{gT^2} \geq \frac{\sin^2 \theta}{2\pi^2} \sqrt{\frac{2\theta}{\pi}} \text{ for } \theta \leq \frac{\pi}{4} \text{ (radians)}. \quad (4)$$

Miche's equation was derived to indicate the wave steepness at which a wave would begin to break on a particular slope. This incipient breaking was defined to occur when the reflection coefficient ( $H_{\text{reflected}}/H_{\text{incident}}$ ) became less than unity. This definition assumes that nonbreaking waves have perfect reflection.

For a given slope, however, there is a range of wave steepnesses between incipient breaking and complete breaking. *Incipient breaking* is the point at which the wave exhibits the first signs of instability, such as slight spilling at the crest. Complete breaking would apply to a wave which has become a plunging breaker or a turbulent spilling breaker in approaching or moving onto a structure or uniform beach slope.

Iribarren Cavanilles and Nogales y Olano (1949) (as referenced in Hunt, 1959) gave a breaking criterion that indicates incident waves meeting the following condition will break.

$$\frac{H}{gT^2} \geq 0.031 \tan^2 \theta. \quad (5)$$

Hunt noted that equation (5) gave a wave steepness value,  $H/gT^2$ , intermediate between complete reflection and complete breaking. He listed the experimental values of Iribarren Cavanilles and Nogales y Olano, but water depths were not included in the data. Nevertheless, both Iribarren Cavanilles and Nogales y Olano (1950) and Hunt (1959) applied equation (5) to slopes fronted by a finite depth. In such cases, depth effects both on incident waves and on the breaking criteria would be expected. Shallow-water and transitional-water waves (defined in Table 1) would be expected to break at steepness values different from deepwater waves.

Available runup data have been obtained for predominantly nondeep-water conditions, where relative depth is a factor in the wave's interaction with a slope. For a given relative depth,  $d_s/gT^2$ , relative runup,  $R/H'_0$ , increases with increasing wave steepness,  $H'_0/gT^2$ , (for a sufficiently low steepness) until reaching a maximum;  $R/H'_0$  values then decrease with even larger values of  $H'_0/gT^2$ . The wave steepness corresponding to maximum relative runup is taken to be the point of incipient breaking, or the largest wave steepness for total reflection. Runup data show that maximum relative runup for  $d_s/gT^2 \geq 0.0793$  (i.e., deep water) occurs at a wave steepness approximately the same as

predicted by Miche (1951) (eq. 4) for incipient breaking. For a given slope, however, maximum relative runup for successively smaller values of  $d_s/gT^2$  occurs at correspondingly smaller values of  $H'_0/gT^2$ . This relationship is shown in Figure 3 which is a set of runup data curves for a smooth 1 on 2.25 slope fronted by a horizontal bottom. Each line represents a different  $d_s/gT^2$  value, and it shows that the maximum  $R/H'_0$  value occurs for a range of  $H'_0/gT^2$  values as  $d_s/gT^2$  varies.

Comparison of data for different slopes indicates that, when  $H$  and  $H'_0$  are considered approximately equal, equation (5) gives roughly the maximum wave steepness for nonbreaking waves. It does not, however, preclude breaking waves for lower values of  $H'_0/gT^2$  and  $d_s/gT^2$ .

Miche (1944) developed the following theoretical equation for non-breaking wave runup for structures in deep water:

$$\frac{R}{H'_0} = \sqrt{\frac{\pi}{2\theta}}, \quad (6)$$

where  $\theta$  is the structure slope measured in radians. This equation is applicable only to waves which are in deep water at the structure toe, and to steeper structure slopes.

Hunt (1959) gave an empirical equation for runup from waves breaking on a structure slope, using equation (5) as a limiting condition, as

$$\frac{R}{H} = 0.405 \frac{\tan \theta}{(H/gT^2)^{1/2}} \text{ for } \frac{H}{gT^2} \geq 0.031 \tan^2 \theta. \quad (7)$$

Hunt's equation was developed from the observation that, for the steeper waves which break on the structure slope, relative depth loses its significance in determining runup.

Since a wave may break on a slope for differing wave steepnesses as relative depth,  $d_s/gT^2$ , varies, Figure 4 was developed from smooth-slope runup data to show the variations. The lines in the figure are based on estimates of the wave steepness values for which a curve of constant  $d_s/gT^2$  becomes tangent to the "line of complete breaking" which is determined empirically for each structure slope from data plots (see example in Fig. 3). The lines in Figure 4 give estimates of the minimum wave steepnesses necessary for incident waves to break on a given slope for the particular relative depths,  $d_s/gT^2$ . From the empirical data, an equation similar to equation (7) but developed for the deepwater wave height is

$$\frac{R}{H'_0} = (\cot \theta)^{-1.04} (4.23)(10)^2 (q-1) \left( \frac{H'_0}{gT^2} \right)^{q-1} \text{ for } \cot \theta \geq 2.0. \quad (8)$$

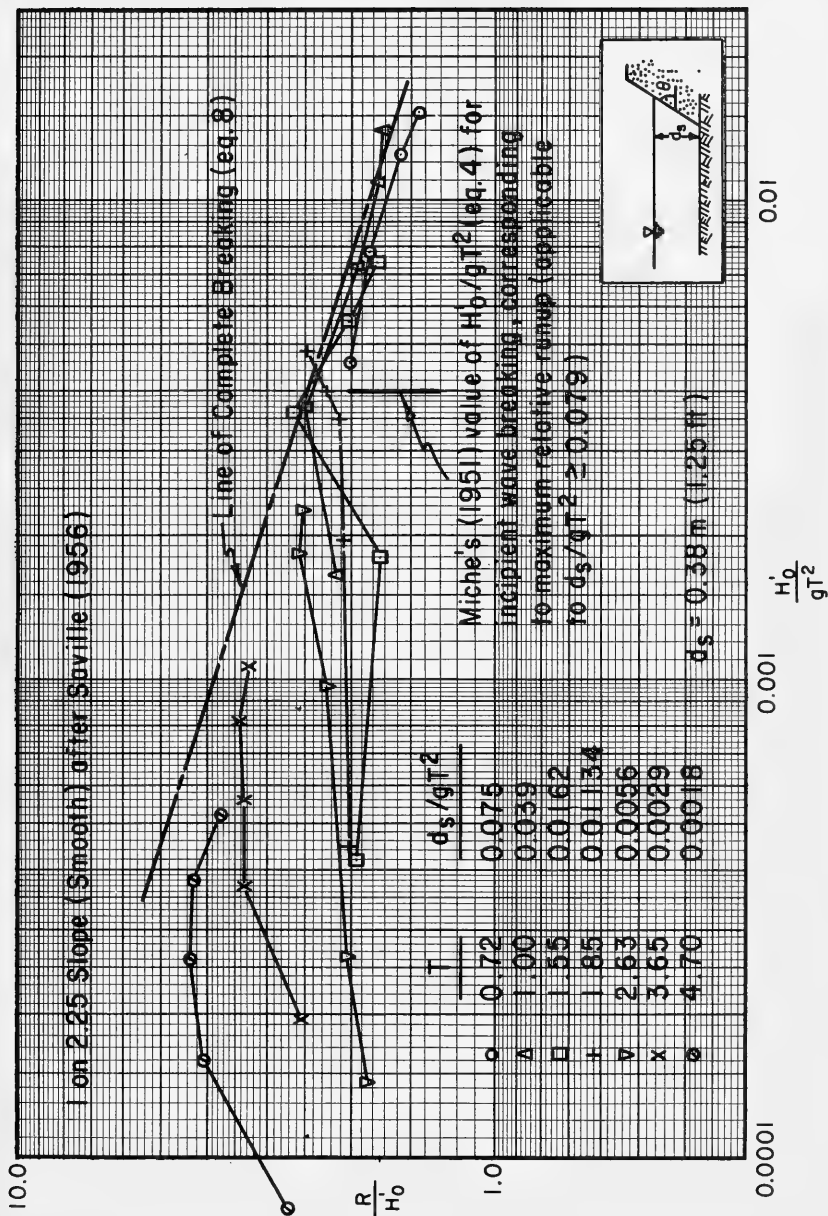

Figure 3. Example of runup data plotted to show trends of lines of  $d_s/gT^2$  and the line of complete breaking given by equation (8).

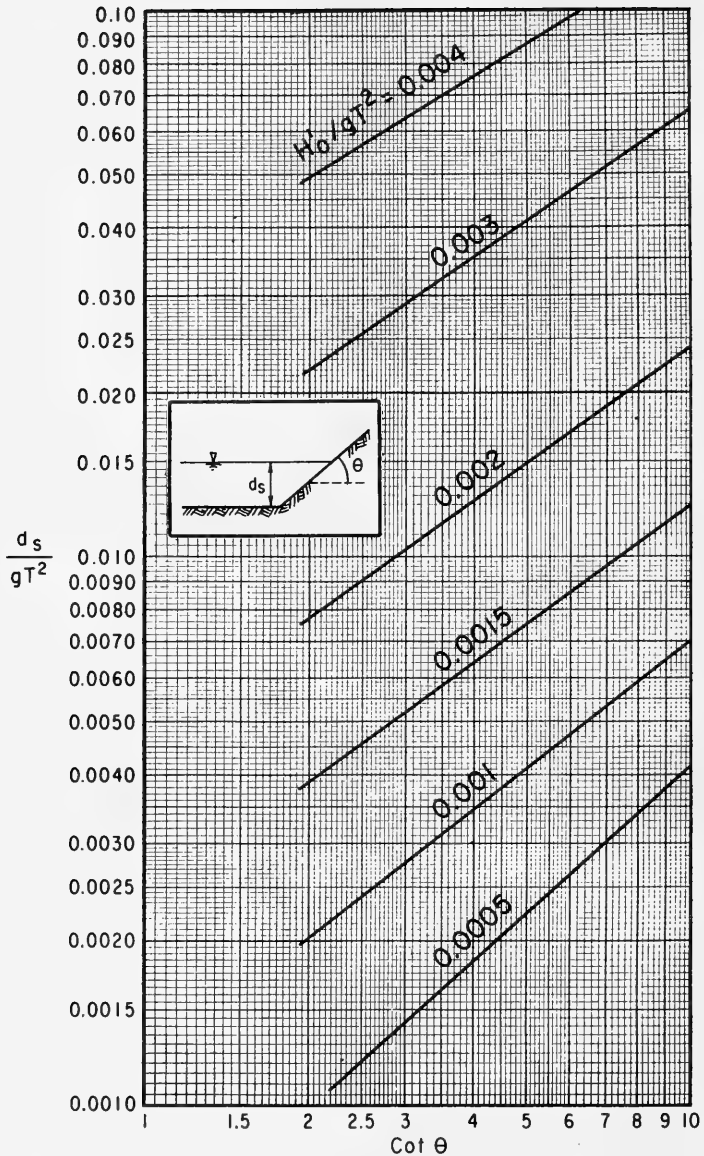

Figure 4. Empirical curves of minimum wave steepness for complete wave breaking at a specified smooth slope and relative depth.



This equation defines the line which is approximately tangent to the  $d_s/gT^2$  lines (see Fig. 3), particularly for the higher  $H'_0/gT^2$  values, and is equivalent to the line of complete breaking in Figure 3 if  $\cot \theta = 2.25$ . The value of  $q$  can be taken from Figure 5 for the appropriate structure slope. Values of  $q$  vary approximately between 0.4 and 0.7. If a value of  $q = 0.5$  is used, equation (8) essentially reduces to Hunt's (1959) equation (eq. 7) for  $H \approx H'_0$ ; however, equation (8) appears to give values which agree somewhat better with experimental values using  $H'_0$ .

Equation (8) is applicable only for smooth slopes where  $\cot \theta \geq 2.0$ . Alternatively, the runup curves given in Section V,1 may be used for  $\cot \theta \geq 2.0$ , but the curves must be used for  $\cot \theta < 2.0$  (i.e., steeper slopes).

Equation (8) was derived from data for a structure on a flat bottom, but it may be applied to structures on sloping bottoms provided  $d_s/H'_0$  is approximately three or greater; i.e., the equation is applicable to waves which do not break before reaching the structure, but do break on the structure slope.

Basically, equation (8) will provide conservative values. Nonbreaking waves will have relative runup equal to or less than predicted by this equation because the relative runup from nonbreaking waves is also a function of relative depth. Relative depth is not included in the equation. If the wave climate at a location consists primarily of waves of high steepness, nearly all waves will break on the structure and equation (8) may be used. Such a situation would exist if the waves meet the conditions of equation (5), using  $H'_0 \approx H$ .

In contrast, some wave climates have predominantly long waves (low  $d_s/gT^2$  values) of low steepness. This situation occurs, for example, on the southwestern coast of the United States. Design wave conditions may include waves which break on the structure slope, in front of the structure because of depth limitations, or nonbreaking waves of the surging type. For example, Vanoni and Raichlen (1966) tested long-period surging waves for a California location. Use of equation (8) to derive smooth-slope runup from surging waves or waves breaking in front of the structure would give relative runup values too high, although such a conservative value might be desired. Furthermore, as noted later in the discussion of the qualitative aspects of runup, the absolute runup,  $R$ , maximum will occur for the maximum steepness of an incident wave train of constant  $d_s/gT^2$  providing the waves do not break before reaching the structure.

A flow chart for runup on a smooth structure slope fronted by a horizontal bottom is given in Figure 6. Variables subscripted with the letter  $i$  are incident wave characteristics at the location where measured.

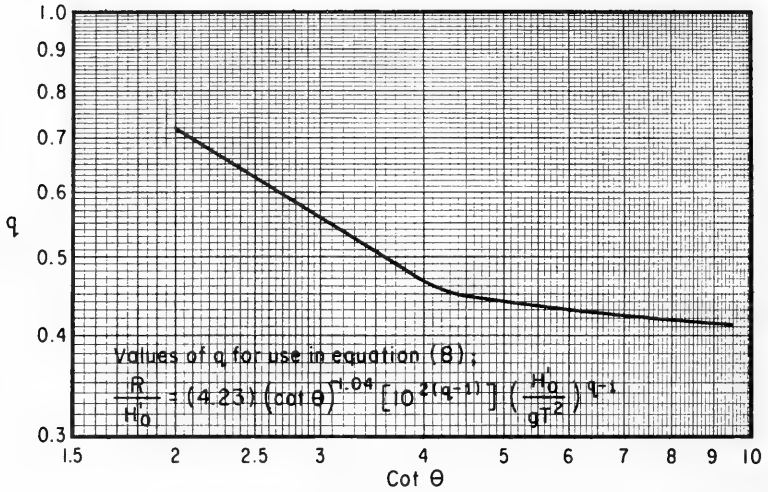

Figure 5. Values of  $q$  for equation (8).



2. Example Problems.

\* \* \* \* \* EXAMPLE PROBLEM 1 \* \* \* \* \*

GIVEN: An impermeable structure has a smooth slope of 1 on 0.5 (63.4° or 1.107 radians) and is fronted by a horizontal bottom. The design depth at the structure toe is  $d_s = 10.0$  meters (33 feet); design wave height is  $H = 1.25$  meters (4.1 feet); and design wave period is  $T = 3.2$  seconds.

FIND: Using the flow chart in Figure 6, determine the expected relative runup of a wave approaching the structure at perpendicular incidence.

SOLUTION: In following the flow chart note that  $d_t$ , the depth where the wave height is measured, is the same as the toe depth,  $d_s$ ;

$$\frac{d_s}{gT^2} = \frac{10}{(9.8)(3.2)^2} = 0.0996 > 0.08 .$$

Therefore,

$$H \approx H'_0 = 1.25 \text{ meters}$$

$$\frac{H'_0}{gT^2} = \frac{1.25}{(9.8)(3.2)^2} = 0.01246$$

$$\frac{\sin^2 \theta}{2\pi^2} \sqrt{\frac{2\theta}{\pi}} = \frac{(0.894)^2}{2\pi^2} \sqrt{\frac{(2)(1.107)}{\pi}} = 0.034 .$$

Thus,

$$\frac{H'_0}{gT^2} < \frac{\sin^2 \theta}{2\pi^2} \sqrt{\frac{2\theta}{\pi}}$$

and from Miche (1951) (eq. 4), this is a nonbreaking wave.

$$\cot \theta = 0.5 < 5 ;$$

Then (from eq. 6)

$$\frac{R}{H'_0} = \sqrt{\frac{\pi}{2\theta}} = \sqrt{\frac{\pi}{2(1.107)}} = 1.19 .$$

Alternatively, the relative runup can be determined using the runup curves given in Section V,1.

\* \* \* \* \*

\* \* \* \* \* EXAMPLE PROBLEM 2 \* \* \* \* \*

GIVEN: An impermeable structure has a smooth slope of 1 on 3 (18.4° or 0.322 radians) and is fronted by a horizontal bottom. The design depth at the structure toe is  $d_g = 10.0$  meters; design wave height is  $H = 1.25$  meters; and design wave period is  $T = 3.2$  seconds.

FIND: Using the flow chart in Figure 6, determine the expected relative runup of a wave approaching the structure at perpendicular incidence.

SOLUTION: This problem differs from example problem 1 only in structure slope; some values are obtained from example problem 1. Following the flow chart,

$$\frac{\sin^2 \theta}{2\pi^2} \sqrt{\frac{2\theta}{\pi}} = \frac{(0.316)^2}{2\pi^2} \sqrt{\frac{2(0.322)}{\pi}} = 0.00229$$

$$\frac{H'_O}{gT^2} = 0.01246 > \frac{\sin^2 \theta}{2\pi^2} \sqrt{\frac{2\theta}{\pi}} .$$

Thus, the wave may be breaking. Next,

$$0.031 \tan^2 \theta = 0.031(0.333)^2 = 0.00345 .$$

Thus,

$$\frac{H'_O}{gT^2} = 0.01246 > 0.031 \tan^2 \theta = 0.00345 ,$$

and the wave is breaking. Also, because  $\cot \theta = 3 > 2$ , equation (8) may be used.

From Figure 5,  $q = 0.555$  for  $\cot \theta = 3$ ;  $q - 1 = -0.445$ .

By equation (8),

$$\begin{aligned} \frac{R}{H'_O} &= (\cot \theta)^{-1.04} (4.23) (10)^2 (q-1) \left( \frac{H'_O}{gT^2} \right)^{q-1} \\ &= (3)^{-1.04} (4.23) (10)^{-0.89} (0.01246)^{-0.445} \\ &= (0.319) (4.23) (0.1288) (7.0387) \\ \frac{R}{H'_O} &= 1.223 . \end{aligned}$$

Equation (8) was derived empirically from small-scale experiments. The calculated value of relative runup should be increased using the appropriate scale-effect correction factor (discussed in Sec. VI).

This problem can also be solved by using the smooth-slope runup curves given in Section V,1.

\*\*\*\*\*  
 \*\*\*\*\* EXAMPLE PROBLEM 3 \*\*\*\*\*

GIVEN: An impermeable 1 on 3 structure is fronted by a horizontal bottom. The design depth at the structure toe is  $d_s = 10.0$  meters; design wave height is  $H = 3.6$  meters (11.8 feet); and wave period is  $T = 13$  seconds.

FIND: Using the flow chart in Figure 6, determine the expected relative runup of a wave approaching the structure at perpendicular incidence.

SOLUTION: The depth where wave height is measured,  $d_t$ , is the same as the structure toe depth,  $d_s$ .

$$\frac{d_s}{gT^2} = \frac{10}{(9.8)(13)^2} = 0.006 < 0.08 .$$

Thus,  $H \neq H'_O$  and  $H'_O$  must be calculated as noted in the flow chart.  $H'_O = H/K_s$ ;  $K_s$  may be determined from equation (2) or from Table C-1 in the SPM. To use the table, determine

$$\frac{d_s}{L_o} = \left( \frac{d_s}{gT^2} \right) (2\pi) = (0.006)(2\pi) = 0.0379 .$$

From Table C-1, read:

$$K_s = \frac{H}{H'_O} \approx 1.075 .$$

Calculate:

$$H'_O = \frac{H}{K_s} = \frac{3.6}{1.075} = 3.349 \text{ meters (11.0 feet)} .$$

Then,

$$\frac{H'_O}{gT^2} = \frac{3.349}{(9.8)(13)^2} = 0.0020 ,$$

$$0.031 \tan^2 \theta = 0.031(0.333)^2 = 0.00344 ,$$

and,

$$\frac{H'_O}{gT^2} = 0.002 < 0.031 \tan^2 \theta = 0.0034 .$$

Therefore, determine if  $H'_0/gT^2$  is greater than the appropriate value in Figure 4. First, from Figure 4, for  $\cot \theta = 3$  and  $d_s/gT^2 = 0.006$ ,

$$\left(\frac{H'_0}{gT^2}\right)_{\text{Fig. 4}} \approx 0.0017.$$

Thus,

$$\frac{H'_0}{gT^2} = 0.002 > \left(\frac{H'_0}{gT^2}\right)_{\text{Fig. 4}} \approx 0.0017,$$

and the wave is breaking. Also,  $\cot \theta = 3 > 2$ , so equation (8) may be used. From Figure 5, for  $\cot \theta = 3$ ,  $q = 0.555$ .

$$q - 1 = -0.445$$

$$\begin{aligned} \frac{R}{H'_0} &= (\cot \theta)^{-1.04} (4.23)(10)^{2(q-1)} \left(\frac{H'_0}{gT^2}\right)^{q-1} \\ &= (3)^{-1.04} (4.23)(10)^{-0.89} (0.002)^{-0.445} \\ &= (0.319)(4.23)(0.1288)(15.887) \end{aligned}$$

$$\frac{R}{H'_0} = 2.76.$$

Again, as in example problem 2, the answer should be increased by the appropriate scale-effect correction factor (discussed in Sec. VI). This example problem can also be derived using the smooth-slope runup curves given in Section V,1.

\*\*\*\*\*

#### IV. QUALITATIVE ANALYSIS

##### 1. General.

Laboratory studies of runup generally have indicated relative runup in terms of wave steepness (e.g.,  $R/H'_0$  versus  $H'_0/gT^2$  or  $R/H$  versus  $H/L$ ), but have not always been specific about relative depth effects. Some studies have presented data for only limited wave conditions. It is important that all variables be investigated. Valid simplifications have been made, but it is necessary to know the limiting conditions for such simplifications.

Evaluation of runup data allows presentation in a manner similar to the conceptual sketch in Figure 7, using one form of relative depth,  $d_s/gT^2$ . The presentation in Figure 7 is particularly useful for results of tests in which a wide range of wave heights are used for each wave period because the curves can be drawn with some degree of confidence.

Data plotted as in Figure 7 can be further analyzed to derive lines of constant  $d_s/H'_0$ . For each  $d_s/gT^2$  line, values of  $H'_0/gT^2$  corresponding to specific  $d_s/H'_0$  values can be determined by

$$\frac{H'_0}{gT^2} = \frac{d_s/(gT^2)}{d_s/H'_0}.$$

Values of  $R/H'_0$  at the appropriate  $H'_0/gT^2$  value can then be determined. This analysis is shown in Figure 8 where lines of  $d_s/H'_0$  have been superimposed on lines of  $d_s/gT^2$  (as shown in Fig. 7). Analyses show that even for high values of  $d_s/H'_0$  (i.e., 8.0, 15.0, 30.0, etc.) the relative depth is important under certain conditions and accounts for much of the scatter in some plots of earlier investigators.

Figure 8 also leads to the reinterpretation of some previous runup plots; e.g., Figure 9 shows the rubble-mound runup curves for various slopes drawn as upper envelopes to the runup data. The right-hand parts of the rubble-mound curves are essentially correct, lying in the region where waves breaking on the structure slopes have little dependence on  $d_s/H'_0$ . The left-hand part of the curves (lower values of  $H'_0/gT^2$ ), however, tend to follow the runup values of the longest wave period tested; a wave period longer than those tested would give higher  $R/H'_0$  values in the lower  $H'_0/gT^2$  region. Lines of constant  $d_s/H'_0$  can be defined for Figure 9, and do have negative or zero slopes similar to the  $d_s/H'_0$  lines in Figure 8 or the smooth-slope lines in Figure 9.

Furthermore, the  $d_s/H'_0$  curves are not necessarily straight lines (on log-log graph paper). On steep structure slopes, with or without a sloping beach, low values of  $d_s/H'_0$  tend to produce a straight line but higher  $d_s/H'_0$  values give a "plateaulike" effect in the approximate range  $0.001 < H'_0/gT^2 < 0.006$ . The lower limit tends to decrease with high  $d_s/H'_0$  values. Figure 10 shows the trends for a steep structure slope fronted by a sloping beach.

The plateau area is attributable, apparently, to the combined results of a change from breaking to nonbreaking waves, for decreasing  $H'_0/gT^2$ , and of a changing shoaling coefficient as the relative depth,  $d_s/gT^2$ , progressively decreases. Flatter slopes, on which waves are breaking for a wider range of  $H'_0/gT^2$ , display less dependence of  $R/H'_0$  on  $d_s/H'_0$  for  $H'_0/gT^2 > 0.001$ .



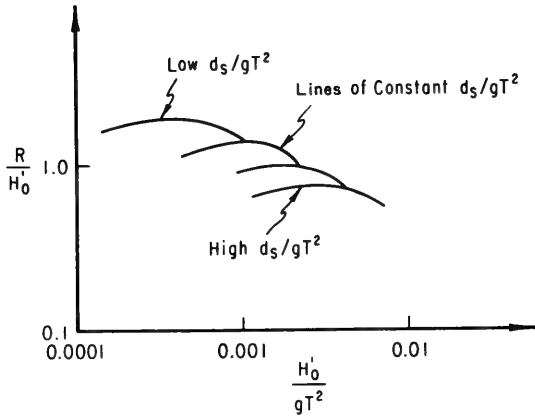

Figure 7. Conceptual sketch of runup data for constant values of  $d_s/gT^2$  and for a fixed slope.

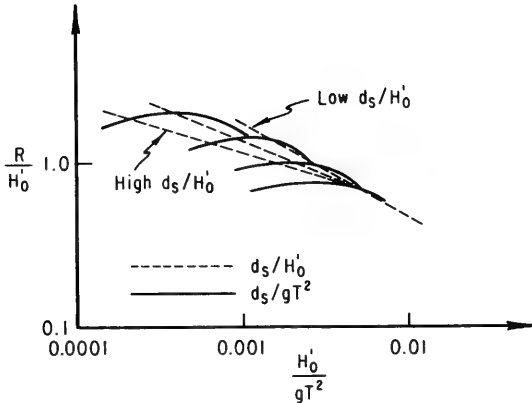

Figure 8. Sketch of lines of  $d_s/H_0'$  related to lines of  $d_s/gT^2$  for a fixed slope.

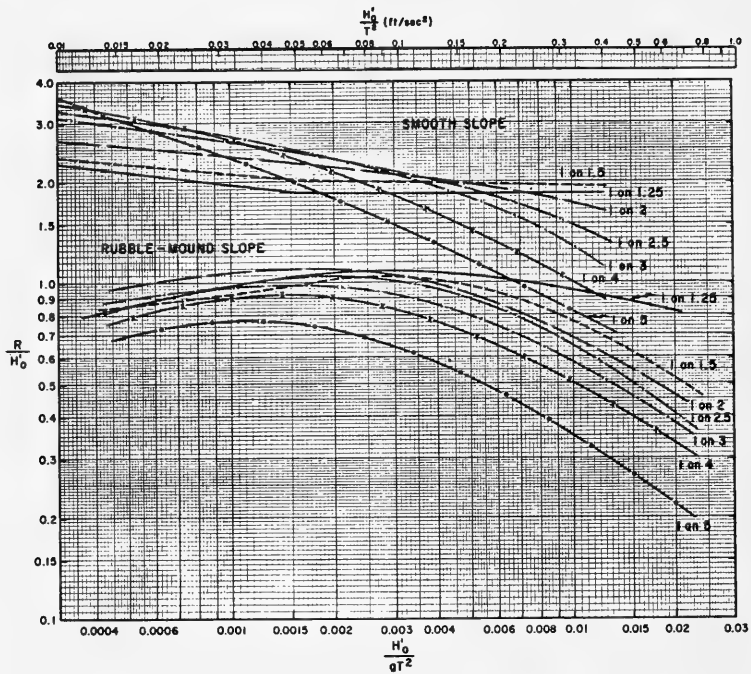

Figure 9. Relative runup comparisons between smooth slopes and permeable rubble-mound slopes;  $d_s/H'_0 > 3.0$ . Rubble-mound slope curves are envelope curves only (U.S. Army, Corps of Engineers, Coastal Engineering Research Center, 1977).

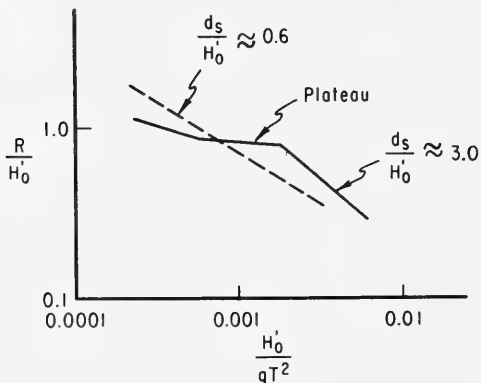

Figure 10. Schematic trends of  $d_s/H'_0$  for steep slopes on a sloping beach.

## 2. Slope Roughness.

For rough-slope data, the use of  $d_s/H'_0$  curves has the advantage of having constant  $H'_0/k_n$  curves coincident with  $d_s/H'_0$  curves. The disadvantage is that relatively few experiments have been undertaken where the armor unit sizes have been varied to allow differentiation of roughness effects from depth effects. Armor sizes have been varied in studies by Hudson (1958), Hudson and Jackson (1962), Jackson (1968a), and Ahrens (1975a). Jackson (1968a) had a rather limited range of  $d_s/H'_0$  values. Ahrens (1975a) tested slopes of 1 on 2.5, 1 on 3.5, and 1 on 5 at near-prototype scale ( $d_s = 4.57$  meters or 15 feet) with a wide range of  $H'_0/gT^2$ . Rough-slope results are discussed in Section V,2.

## 3. Effects of Beach Slope Fronting a Structure.

The presence of a slope in front of a structure may or may not affect a wave. Effects of slope will depend on wave conditions and the local geometry or laboratory test arrangement. Three cases may be defined (see also Fig. 2):

(a) Case 1.  $d_s/gT^2 \geq 0.0793$ . An incident wave that has deepwater characteristics at the *structure* toe will not be influenced by the slope in front of the structure. A horizontal bottom at the same depth,  $d_s$ , would also have no effect on the wave.

(b) Case 2.  $d_s/gT^2 < 0.0793$ ;  $d/gT^2 \geq 0.0793$ . An incident wave that has deepwater characteristics at the toe of the *beach* slope will not be influenced by the bottom (horizontal or sloping) seaward of the beach slope, but the wave will be modified to some degree by the beach slope, dependent on the toe depth of the structure. This case is the desired condition for laboratory tests where only a particular beach slope (but not the slope length) is specified. The implication is that the beach slope extends into deep water.

(c) Case 3.  $d_s/gT^2 < 0.0793$ ;  $d/gT^2 < 0.0793$ . An incident wave that has transitional or shallow-water characteristics at the toe of the beach slope will be modified by the beach slope. The beach-slope effect is not only a function of relative toe depth,  $d_s/gT^2$ , but also a function of the relative depth seaward of the beach slope,  $d/gT^2$ . The latter relationship is expressed equivalently in this study with the dimensionless variable  $\ell/L$ , where  $\ell$  is the horizontal beach-slope length and  $L$  is the wavelength for a given period,  $T$ , in the uniform depth seaward of the beach slope. Design curves for smooth-slope runup are limited to  $\ell/L \geq 0.5$  in this study since there are insufficient data to adequately define the effects of shorter beach-slope lengths on runup.

However, consideration of the various relations between beach-slope geometry, relative depths, and wave shoaling allows the following expectations (conditions) of runup:

(a) Condition 1. Structure fronted by horizontal bottom. For a given  $d_s/H'_0$  and  $H'_0/gT^2$ , this geometry results in the highest relative runup. (However, smaller  $d_s/H'_0$  values are obtained when sloping beaches are present, with consequently higher relative runup in some cases.)

(b) Condition 2. Structure fronted by a sloping beach extending to deep water (same as case 2). For the same  $d_s/H'_0$  and  $H'_0/gT^2$  values noted in condition 1, this geometry gives the minimum relative runup (but the relative runup may be comparable to other geometries for certain conditions).

(c) Condition 3. Structure fronted by a sloping beach terminating in shallow water (same as case 3). For the same wave conditions given in conditions 1 and 2, this geometry allows intermediate values of relative runup which is dependent on the relative beach-slope length,  $l/L$ . For this study, relative runup was assumed, somewhat arbitrarily, to be negligibly dependent on  $l/L$  for  $l/L \geq 0.5$ . (This assumption allowed most of the small-scale smooth-slope data to be incorporated in the design curves of Sec. V,1.) Furthermore, in instances where this assumption is applicable, the geometry is considered essentially comparable to case 2. As  $l/L$  decreases from  $l/L \approx 0.5$ , and keeping  $d_s/H'_0$  and  $H'_0/gT^2$  constant, relative runup would increase and asymptotically approach the relative runup for a structure on a horizontal beach with the same  $d_s/H'_0$  value, if applicable. (A value of  $d_s/H'_0 = 0.6$ , for example, would not be obtained in the presence of a horizontal bottom.)

(d) Condition 4. Varying beach-slope angles. For given  $d_s/H'_0$ ,  $H'_0/gT^2$ , and for either deep water or a uniform depth seaward of the beach slope, as the beach-slope angle becomes smaller, relative runup increases if the wave does not break in front of the structure. The relative runup would asymptotically approach the values for runup on a structure sited on a horizontal bottom. If the wave breaks in front of the structure while passing over a flatter beach slope but does not break over a steeper beach, then relative runup may be higher on the structure fronted by the steeper beach.

(e) Condition 5. Varying  $d_s/H'_0$  values for a structure fronted by a sloping beach. As  $d_s/H'_0$  increases, the beach slope becomes less important for the relative runup of the higher wave steepnesses.

The runup expectations in these conditions are based on the assumption that the shoaling coefficient,  $H/H'_0$ , for the particular toe depth,  $d_s$ , is equal to or greater than one. Actually, this assumption is not always true since the steeper waves generally occur in the larger relative depths ( $d_s/gT^2 > 0.009$ ) for which  $H/H'_0$  may vary between 0.913 and 1.0. Any effect of this relationship on relative runup, however, is apparently obscured by data variability and so is not considered in the above examples.

#### 4. Breaking Waves.

Waves are classified as breaking or nonbreaking according to two different definitions. The first definition is based on whether a wave breaks at or seaward of a structure toe (region I, Fig. 11). The second and more inclusive definition is based on whether a wave breaks at all, either on or seaward of the structure (in either region I or II, Fig. 11). A nonbreaking wave by the second definition is assumed for some purposes to represent total reflection on smooth slopes, although there is certainly energy loss on a rubble slope even if waves are nonbreaking.

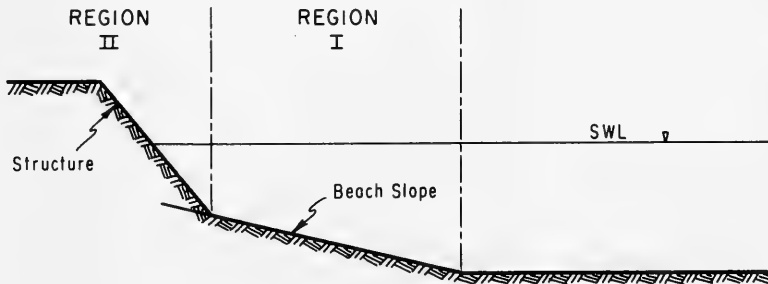

Figure 11. Regions of breaking waves for depth-related instabilities.

Jackson (1968a), for example, reported tests on rubble structures with various armor units where waves were not breaking seaward of the structure toe. He referred to "nonbreaking" waves; however, conditions were such that some waves would be expected to break on the structure when past the structure toe (region II, Fig. 11).

Palmer and Walker (1970), however, studied runup on a 1 on 1.5 rubble slope fronted by a 1 on 50 beach. Their objective was the design of a structure subjected to breaking waves--waves breaking either on the structure or seaward of the structure toe. Their study fits the second definition of breaking waves; i.e., breaking in either region I or region II in Figure 11.

Saville (1956) gave results of extensive smooth-slope testing, and included waves breaking in both regions I and II (Fig. 11), but specific conditions for breaking were not given. However, by comparing theoretical breaking wave conditions with some experiments for which the breaking wave conditions were given (e.g., Palmer and Walker, 1970), the following discussion is considered applicable.

Figure 12(a) shows an example  $d_s/gT^2$  curve for a structure sited on a sloping beach; Figure 12(b) is for a structure sited on a flat beach. For a wide range of  $H_o'/gT^2$  values, there is a maximum relative runup ( $R/H_o'$ ) for each  $d_s/gT^2$  curve. This maximum value may be on a rather sharp, peaked curve or on a broad, flat curve. The positive

slope part of the curve represents nonbreaking wave conditions. The maximum value of  $R/H'_0$  on the curve represents initiation of breaking, followed by constant or decreasing relative runup for increasing wave steepness. The above interpretation is consistent with Granthem (1953), who observed conditions when waves were breaking or nonbreaking. Similar observations were also made by Hunt (1959), Hosoi and Mitsui (1963), Le Mehaute, Koh, and Hwang (1968), Raichlen and Hammack (1974), and the Technical Advisory Committee on Protection against Inundation (1974).

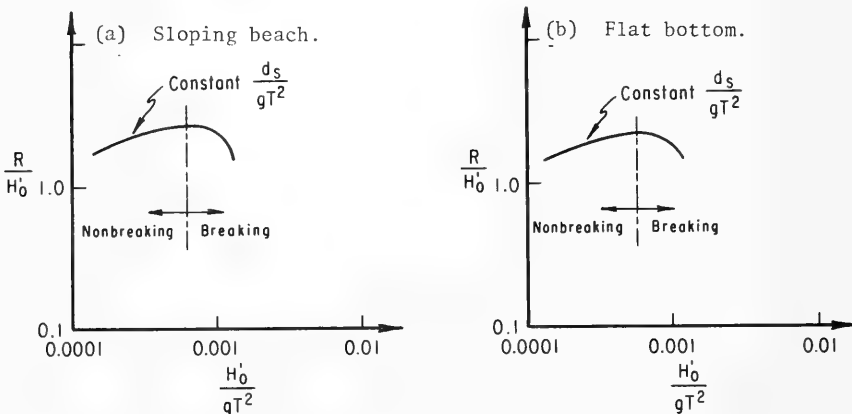

Figure 12. Sample lines of constant  $d_s/gT^2$  for runup on structures on sloping and flat beaches (values of  $d_s/gT^2$  not necessarily the same).

Another characteristic of the runup curve for a structure fronted by a sloping beach is shown in Figure 12(a). Waves breaking seaward of the structure toe will have relative runup equal to or less than that for waves breaking at the structure toe. This breaking condition exists for wave steepness values for which the negative slope of the  $d_s/gT^2$  curve is equal to or steeper than the slope of a line of constant  $R/gT^2$  (Fig. 13). The maximum dimensional runup will occur for the wave steepness value where the  $d_s/gT^2$  curve becomes tangent to a line of constant  $R/gT^2$ .

### 5. Maximum Runup.

Maximum *relative* runup,  $R/H'_0$ , for a range of wave conditions is readily determined from dimensionless plots. However, maximum *dimensional* runup,  $R$ , for the given conditions, is not necessarily coincident with maximum relative runup,  $R/H'_0$ .

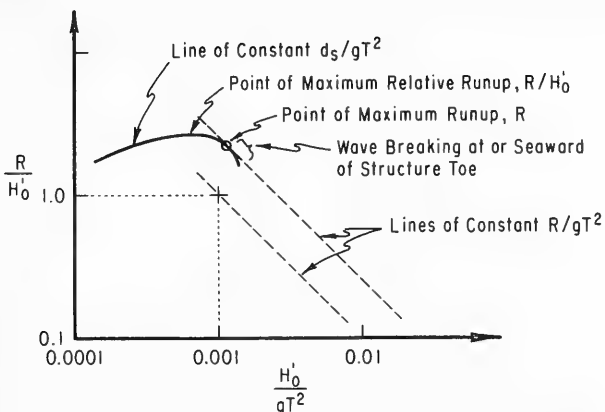

Figure 13. Conditions for wave breaking on beach slope in front of structure.

For structures sited on *horizontal* bottoms, the maximum dimensional runup,  $R$ , for a given relative depth,  $d_s/gT^2$ , occurs for the maximum wave steepness. The maximum steepness of an incident wave is limited according to the theoretical equation (Miche, 1944),

$$\left(\frac{H}{L}\right)_{max} = 0.14 \tanh\left(\frac{2\pi d}{L}\right). \quad (9)$$

The actual maximum wave steepness measured in runup experiments is less because of reflection effects from the structure and, in laboratory testing, because of difficulty in generating a nonbreaking wave of such steepness. Saville's (1956) tests had maximum steepness values equal to 70 percent of that predicted for the shorter wave periods, and  $\approx 57$  percent of that predicted for the longer periods. Only a few other experiments have had greater wave steepnesses. It is unclear whether these reduced wave steepness values were chosen maximums, functions of equipment limitations, or experimental maximums designed to prevent the wave's breaking in transit to the structure.

For structures sited on *sloping* beaches, the maximum dimensional runup occurs for waves breaking at or near the structure toe. Graphically, for constant  $d_s/gT^2$ , maximum runup,  $R$ , occurs for the wave steepness where the negative slope of the  $R/H_0'$  versus  $d_s/gT^2$  curve becomes steeper than the slope of a line of constant  $R/gT^2$  (Fig. 13).

However, the smooth-slope design curves given in Section V,1 do not list values of  $d_s/gT^2$ . In using these curves, the following comments on relative runup and dimensional runup are important. For structures sited on horizontal beaches, for a given wave steepness, both the

maximum relative runup and the maximum dimensional runup occur at the minimum  $d_s/H'_0$  value. For structures sited on a 1 on 10 sloping bottom, maximum dimensional runup may or may not be coincident with the maximum relative runup determined for a range of wave conditions. If depth,  $d_s$ , and wave steepness are assumed constant, then maximum relative runup occurs when  $1.0 \leq d_s/H'_0 \leq 1.5$ , but maximum dimensional runup occurs when  $d_s/H'_0$  is a minimum (in this study when  $d_s > 0$ , then  $(d_s/H'_0)_{min} = 0.6$ ). In cases where a beach slope is flatter than 1 on 10, then for a given wave steepness, the maximum relative runup will occur for somewhat higher  $d_s/H'_0$  values ( $1.5 \leq d_s/H'_0 \leq 2.0$ ). However, if wave height,  $H'_0$ , and wave steepness are held constant, the maximum dimensional runup will be coincident with maximum relative runup as  $d_s/H'_0$  varies (i.e., as  $d_s$  changes). The maximums ( $R/H'_0$  and  $R$ ) may occur at any value of  $d_s/H'_0$  (including  $d_s/H'_0 = 0$ ) depending on the wave steepness being considered. Runup maximums would occur at intermediate values of  $d_s/H'_0$  ( $1.0 \leq d_s/H'_0 \leq 1.5$ ) for high values of  $H'_0/gT^2$ , but at low values of  $d_s/H'_0$  for low values of  $H'_0/gT^2$ . For a given wave period and constant depth,  $d_s$ , (with wave steepness varying as  $d_s/H'_0$  varies), maximum dimensional runup is generally not coincident with maximum relative runup; furthermore, the maximum dimensional runup may occur at other than the minimum  $d_s/H'_0$  value. These relationships are highlighted in example problem 7 in Section V,1,e.

## V. EXPERIMENTAL RESULTS

### 1. Smooth Slopes.

a. Past Research. Smooth slopes are simplest to construct in experiments, and the results are easiest to analyze. Consequently, many laboratory tests have been carried out using smooth slopes. A partial listing of runup studies conducted with smooth slopes and the ranges of conditions tested are given in Table 2. Wave conditions for most of these studies appear to cover a wide range, but many of the actual conditions tested ( $H'_0/gT^2$  and  $d_s/gT^2$  pairs) are rather limited.

Grantham (1953) was one of the earliest to investigate the effects of wave steepness, relative depth, and structure slope on runup. However, runup values are generally below values determined from this study's design runup curves based principally on data of Saville (1956) and Savage (1958). Some differences are appreciable, and the reasons are unclear since the model dimensions were similar. Saville (1955), in conjunction with overtopping experiments, reported runup results for structures sited on a 1 on 10 beach. He tabulated the maximum observed runup values for each condition but the results had greater variations in trends than shown by later reports using average values. Saville (1956) conducted a large number of tests investigating effects of relative depth, relative steepness, structure slope, and beach slope. Tests of beach-slope effects were limited to structures sited on the horizontal wave tank bottom and on a 1 on 10 slope.



Table 2. Smooth-slope runup test conditions.

Source	Profile <sup>1</sup>	Structure slope (cot θ)	Beach slope (cot β)	$\frac{H_0}{gT^2}$	$\frac{d_p}{gT^2}$
Grantham (1953)	A	Vertical; 0.27, 0.58, 1.0, 1.43, 1.73, 2.14, 2.75, 3.73	----- <sup>2</sup>	0.0006 to 0.0181	0.004 to 0.068
Saville (1955)	B	Vertical; 1.5, 3.0	10.0	0.00041 to 0.016	0, and 0.00062 to 0.0319
Saville (1956)	A	1.5, 2.25, 3.0, 4.0, 6.0, 10.0	-----	0.000015 to 0.0167	0.001054 to 0.0899
Saville (1956)	B	1.5, 2.25, 3.0, 4.0, 6.0, 10.0	10.0	0.000015 to 0.0167	0, and 0.000267 to 0.02276
Hudson, Jackson, and Cuckler (1957)	A	2.0, 3.0, 4.0, 6.0, 10.0	-----	0.0042 to 0.0113	0.01027 and 0.0153
Hudson, Jackson, and Cuckler (1957)	B	2.0, 3.0, 4.0, 6.0, 10.0	10.0	0.0042 to 0.0113	0.00317 to 0.0153
Saville (1958)	B	3.0, 6.0	10.0	0.00011 to 0.0135	0.000485 to 0.0182
Shinohara (1958)	A	10.0	-----	0.000159 to 0.0143	Not given
Sato and Kishi (1958)	B	2.0	17.0	0.00064 to 0.0108	0, and 0.00159 to 0.0226
Savage (1958, 1959)	A	Vertical; 0.5, 1.0, 1.5, 2.25, 4.0, 6.0, 10.0, 30.0	-----	0.000062 to 0.0143	0.00176 to 0.0749
Sorensen and Willembrock (1962)	A	4.0	-----	0.00183 to 0.01490	0.01336 to 0.0969
Talian and Vesilind (1963)	A	4.0	-----	0.00245 to 0.0207	0.01698 to 0.079
Hosoi and Mitsui (1963)	B (modified)	1.5	Complex	0.00095 to 0.0127	-0.00716 to 0.0178 (Negative for toe of structure above SWL)
Tominaga, Hashimoto, and Sakuma (1966)	B	Vertical; 0.5, 1.0, 2.0, 3.0	20.0, 30.0	0.0004 to 0.0127	0, and 0.00159 to 0.0159
Bucci and Whalin (1969)	B	22.0	≈70.0	$3 \times 10^{-6}$ to 0.0068	0.00009 to 0.0109
Bucci and Whalin (1970)	A	2.0, 4.0, 6.0, 10.0, 20.0, 30.0	-----	0.000166 to 0.0195	0.00776 to 0.0634
Nussbaum and Colley (1971)	A	3.0	-----	0.00110 to 0.01831	0.00989 to 0.0817
Raichlen and Hammack (1974)	B	2.0	200.0	0.0002 to 0.0278	0.00261 to 0.0621
Takada (1974)	B	Vertical	10.0	0.00286 to 0.00891	0, and 0.000796 to 0.0143
Ahrens (1975b)	A	10.0	-----	0.000030 to 0.01395	0.00176 to 0.0749

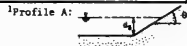

<sup>2</sup>Not applicable.

Hudson, Jackson, and Cuckler (1957) reported results of runup and overtopping for structure slopes ranging from 1 on 2 to 1 on 10 with the structure slope fronted by a 1 on 10 beach slope. A rather narrow range of wave steepness was investigated but different water depths were used and the structure geometry was varied, including the beach-slope length,  $\ell$ . Relative runup results varied for the differing geometries, even for equal wave conditions ( $H'_0/gT^2$  and  $d_g/gT^2$ ), and the variations probably result in part from the differing relative beach-slope length,  $\ell/L$ . However, the data are insufficient to further define the effect.

Saville (1958) described large-scale tests and tests for identical conditions at one-tenth scale. A wide range of wave steepnesses was tested, but relative depth ( $d_g/H'_0$ ) had a rather narrow range. These tests were used by Saville to develop scale-effect correction factors.

Shinohara (1958) investigated breaker heights and wave runup on 1 on 10 and 1 on 20 slopes. His runup values for the 1 on 10 slope were less than those of Saville (1956), and the 1 on 20 runup values were bracketed by Saville's curves for the 1 on 10 and 1 on 30 slopes. Savage (1958) gave runup test results for smooth and rough slopes sited on a horizontal surface; results were plotted to emphasize roughness and permeability. In Savage (1959), the same basic data were given, but the data were plotted as  $R/H'_0$  versus  $H'_0/T^2$  for each specific structure slope and roughness. Sorensen and Willenbrock (1962) studied runup on a smooth 1 on 4 slope, both with and without a berm; Talian and Vesilind (1963) provided additional data for the same structure but used different water depths. The wave heights were measured values; however, when converted to deepwater values, the results for the smooth slope agree well with Saville's (1956) data. Sorensen and Willenbrock's results are also incorporated in Herbich, Sorensen, and Willenbrock (1963).

Hosoi and Mitsui (1963) tested runup on a 1 on 1.5 slope for complicated geometry seaward of the structure which in some cases was located shoreward of the waterline. Tominaga, Hashimoto, and Sakuma (1966) described runup on four different structure slopes sited on 1 on 20 and 1 on 30 beach slopes. Their results for the 1 on 20 beach showed relative runup for the lower wave steepnesses and for  $d_g/H'_0 \leq 1.0$  to be lower than runup results obtained on a structure fronted by a 1 on 10 slope, such as tested by Saville (1956). Results for other conditions seem comparable for the two beach slopes. Bucci and Whalin (1969) generated low steepness waves for runup on slopes of approximately 1 on 22 in a three-dimensional model of Monterey Bay, California. Bucci and Whalin (1970) conducted two-dimensional runup studies using high steepness waves, and the use of the results allows extension of the range of high wave steepness runup values beyond those used in the SPM relative runup curves. Nussbaum and Colley (1971) conducted a limited study on smooth slopes in conjunction with tests on soil-cement stepped slopes. Ahrens (1975b) used a new runup gage which gave results for a 1 on 10 slope comparable to those of Saville (1956) and Savage (1959).

The SPM presents a set of smooth-slope runup curves based principally on Saville (1956) and Savage (1958; 1959). Relative depth ( $d_s/H'_0$ ) effects are included in the set of curves, but are given as ranges of values. The data were reanalyzed for this study to determine runup curves for specific  $d_s/H'_0$  values. Having such specific conditions not only allows direct runup comparisons with rough-slope data for the same wave conditions and structure geometry, but allows better interpolation between sets of curves for intermediate  $d_s/H'_0$  values, and allows calculation of specific values of the alternate relative depth,  $d_s/gT^2$ . The smooth-slope design curves are discussed below.

b. Smooth Structure Fronted by Horizontal Bottom. Only limited runup data were obtained by Saville (1956) and Savage (1959) for a structure on a horizontal bottom in depths  $d_s/H'_0 < 3.0$ . However, much data were obtained for  $d_s/H'_0 > 3.0$ . The SPM provides only one set of curves for  $d_s/H'_0 > 3.0$  which tends to give conservative results (high predictions) for large  $d_s/H'_0$  values. It is incorrect (although stated in some recent studies) that depth effects are not present for  $d_s/H'_0 > 3.0$ . Figures 14, 15, and 16 give relative runup for  $d_s/H'_0$  values of 3.0, 5.0, and 8.0. Larger values were not used because a requirement for large  $d_s/H'_0$  values would be rare; when such a requirement occurs (e.g., in a reservoir), the set of curves for  $d_s/H'_0 = 8.0$  should be used. When runup values are required for  $d_s/H'_0 < 3.0$ , the curves for  $d_s/H'_0 = 3.0$  should be used.

Relative depth effects are negligible for a particular wave steepness in those instances when waves are breaking on the structure slope. This observation has been made by various researchers. It can also be shown by examination of the design curves; e.g., a comparison of Figures 14, 15, and 16 for  $H'_0/gT^2 = 0.0124$  shows that, for  $\cot \theta \geq 3.0$ , all three figures have approximately equal relative runup for a particular slope.

c. Smooth Structure Fronted by 1 on 10 Beach Slope and Zero Toe Depth ( $d_s = 0$ ). A structure with zero toe depth ( $d_s = 0$ ) presents a special case in that relative depths seaward of the beach slope are not adequately specified by  $d_s/H'_0 = 0$ . Therefore, in the case of zero toe depth, wave conditions are specified using the depth,  $d$ , at the toe of the beach slope. Figures 17, 18, and 19 present the results for  $d/H'_0$  (not  $d_s/H'_0$ ) values of 3.0, 5.0, and 8.0 with a 1 on 10 bottom slope.

d. Smooth Structure Fronted by 1 on 10 Beach Slope and Toe Depth Greater than Zero ( $d_s > 0$ ). Design curves based on small-scale runup data (Saville, 1956) for a smooth structure fronted by a 1 on 10 beach slope are given in Figures 20 to 23. The basic data were obtained principally for cases where the relative beach-slope length,  $\ell/L$ , was equal to or greater than one-half (this limit is shown in the figures).

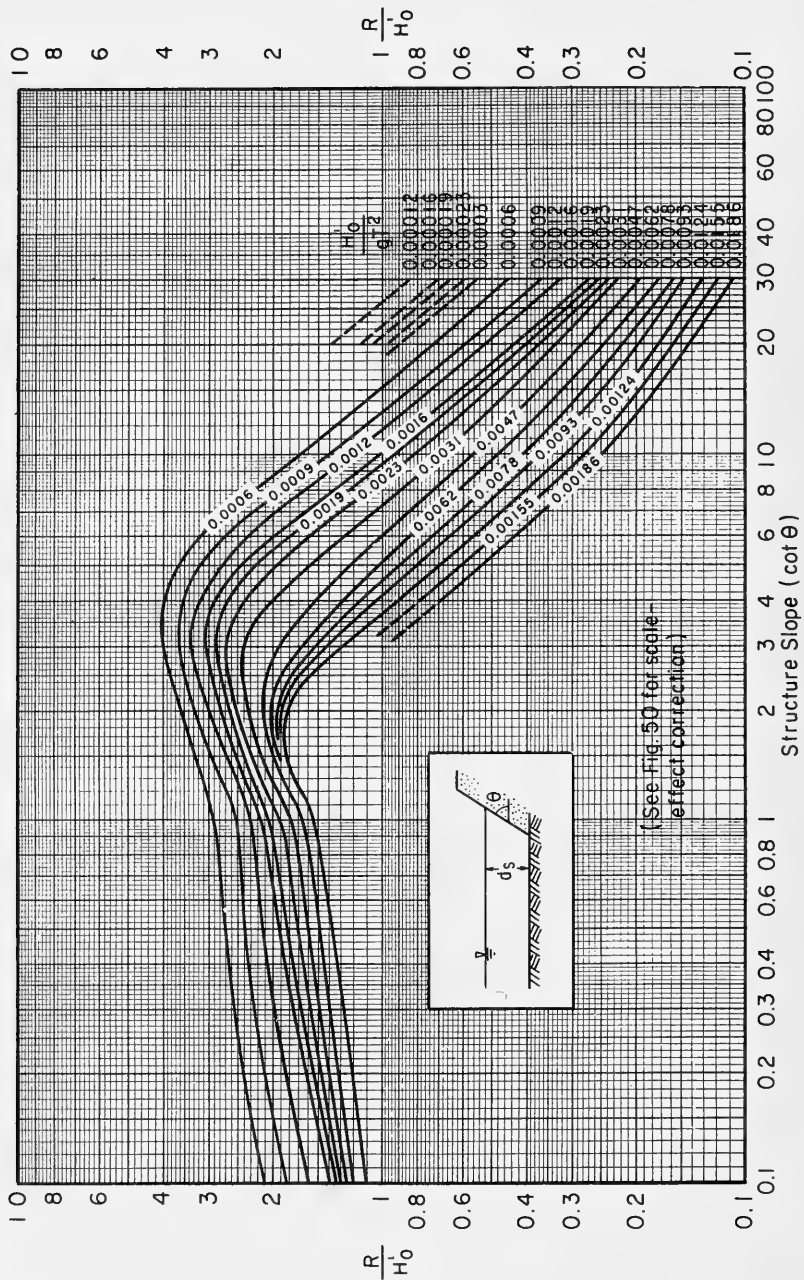

Figure 14. Relative runoff for smooth slopes on horizontal bottom;  $d_g/H_0 = 3.0$ .

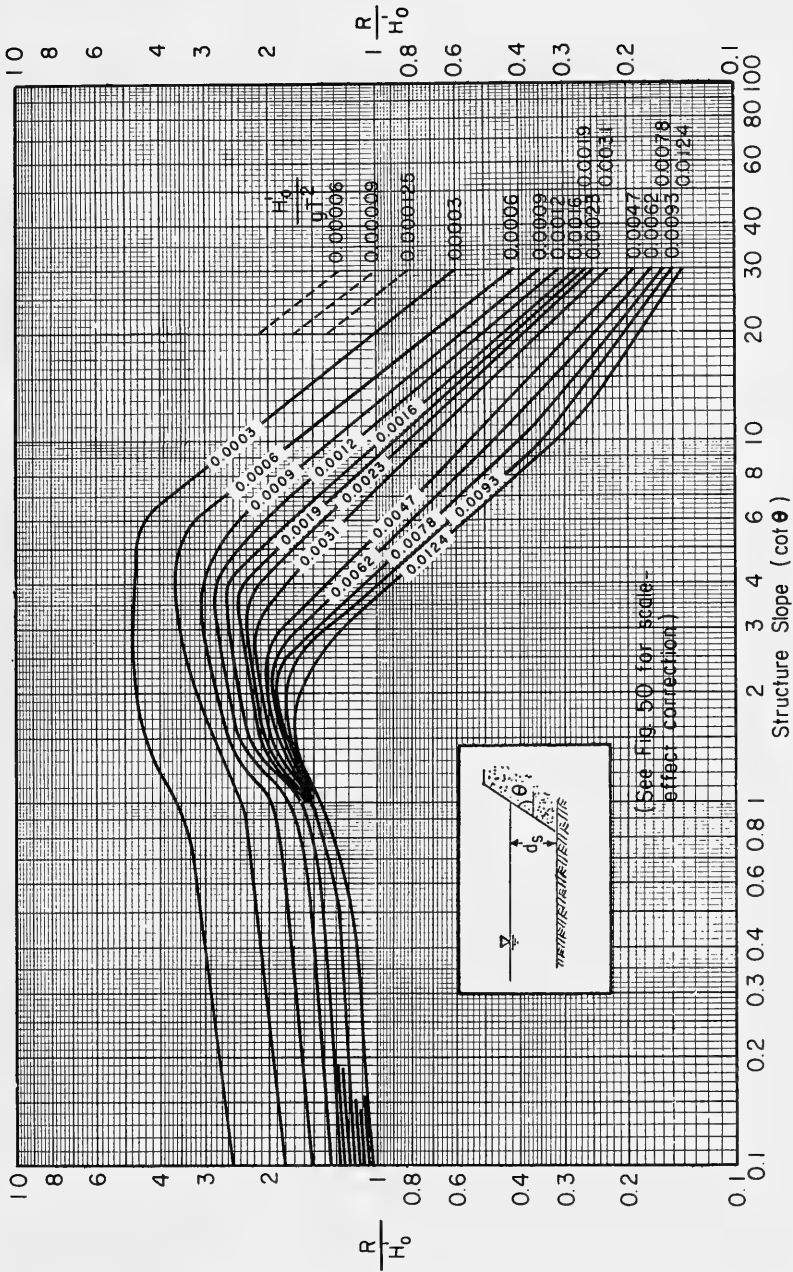

Figure 15. Relative runoff for smooth slopes on horizontal bottom;  $d_g/H_0 = 5.0$ .



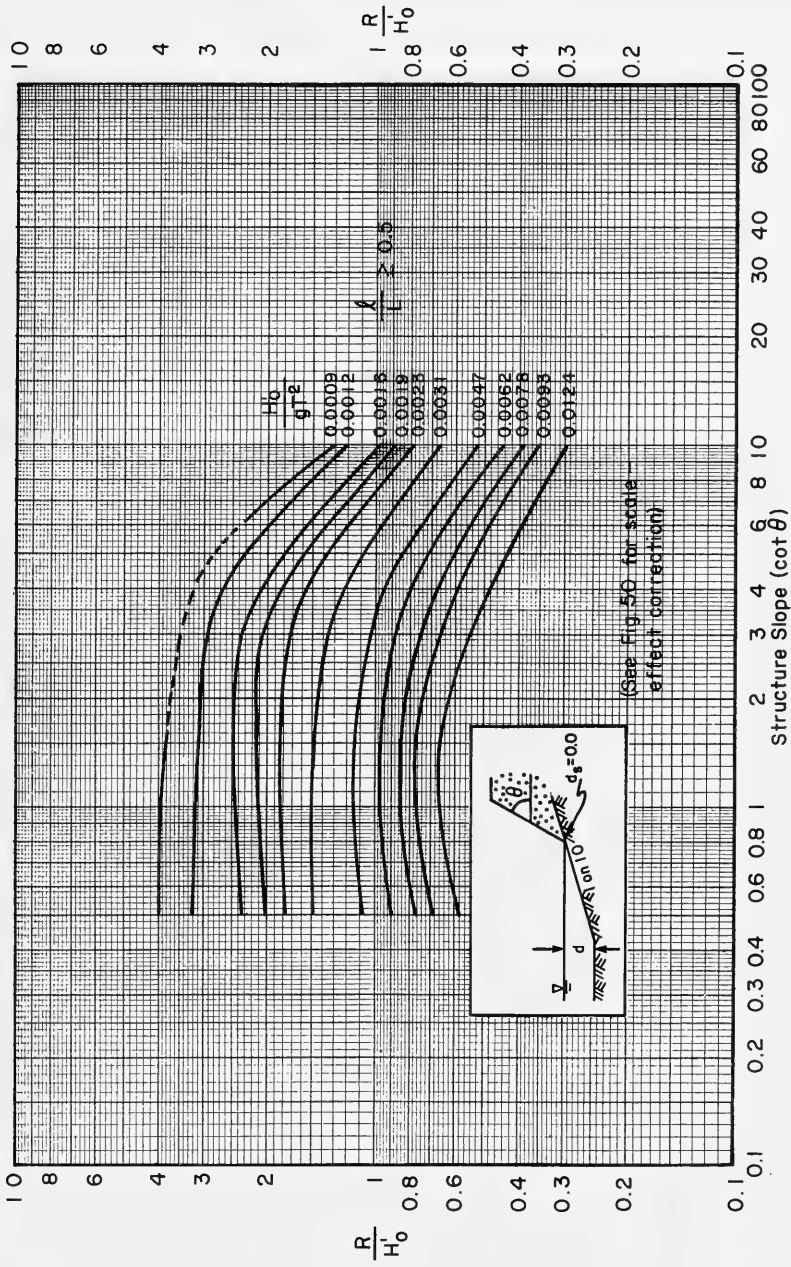

Figure 17. Relative runoff for smooth slopes on 1 on 10 beach;  $d_s = 0$ ;  $d/H_0 = 3.0$ .

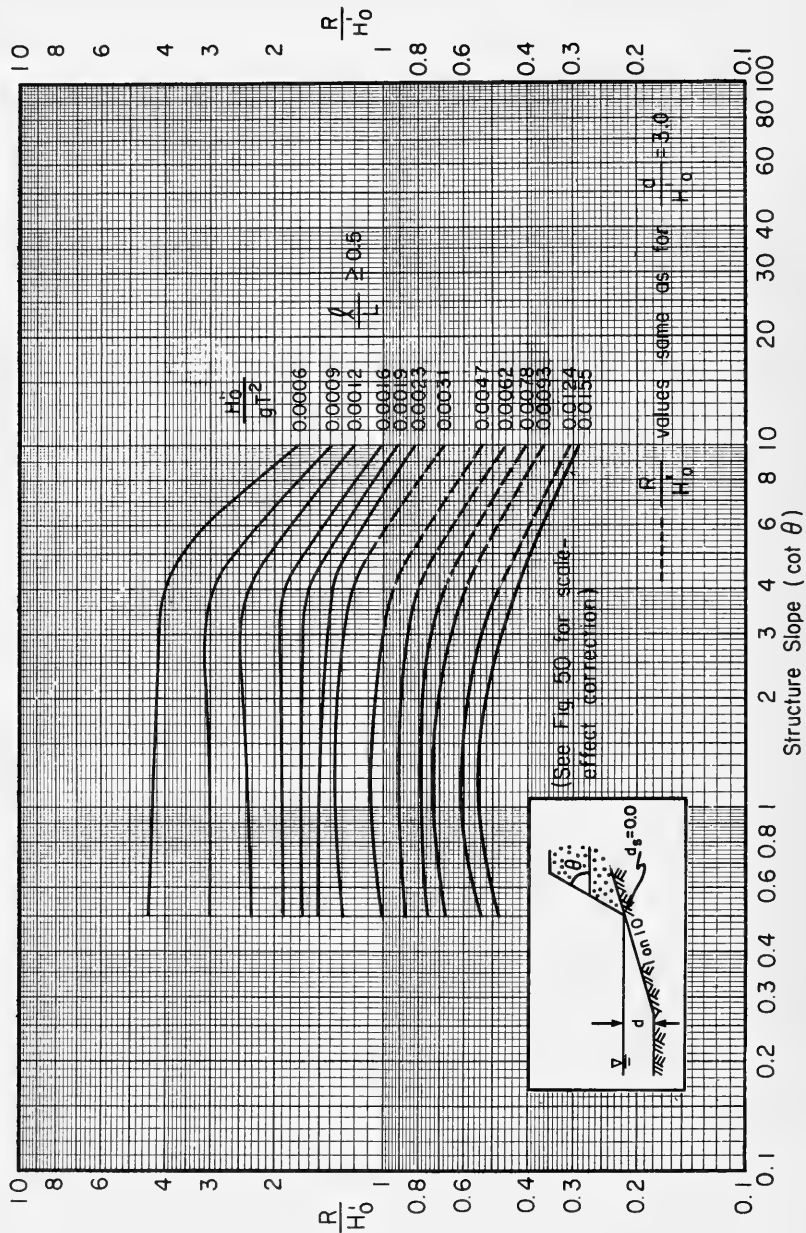

Figure 18. Relative runoff for smooth slopes on 1 on 10 beach;  $d_s = 0$ ;  $d/H_0' = 5.0$ .



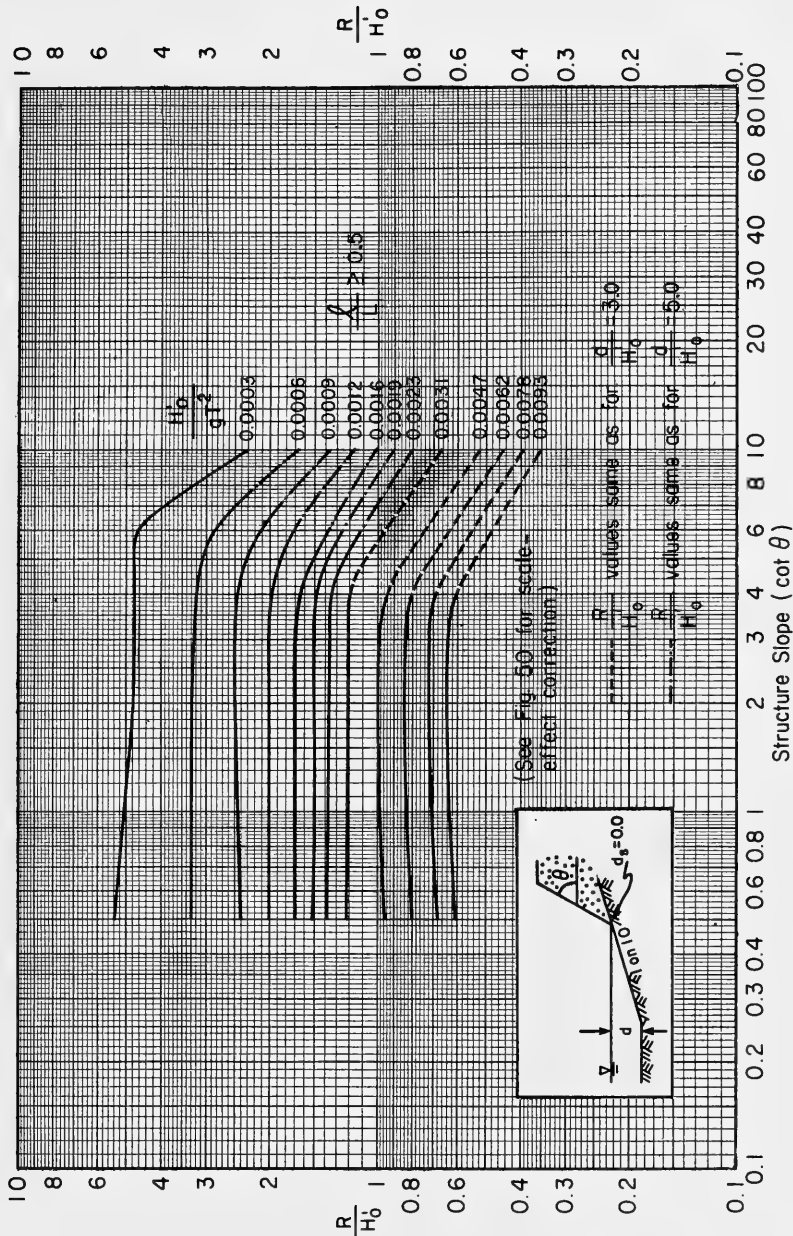

Figure 19. Relative runup for smooth slopes on 1 on 10 beach;  $d_s = 0$ ;  $d/H_0 = 8.0$

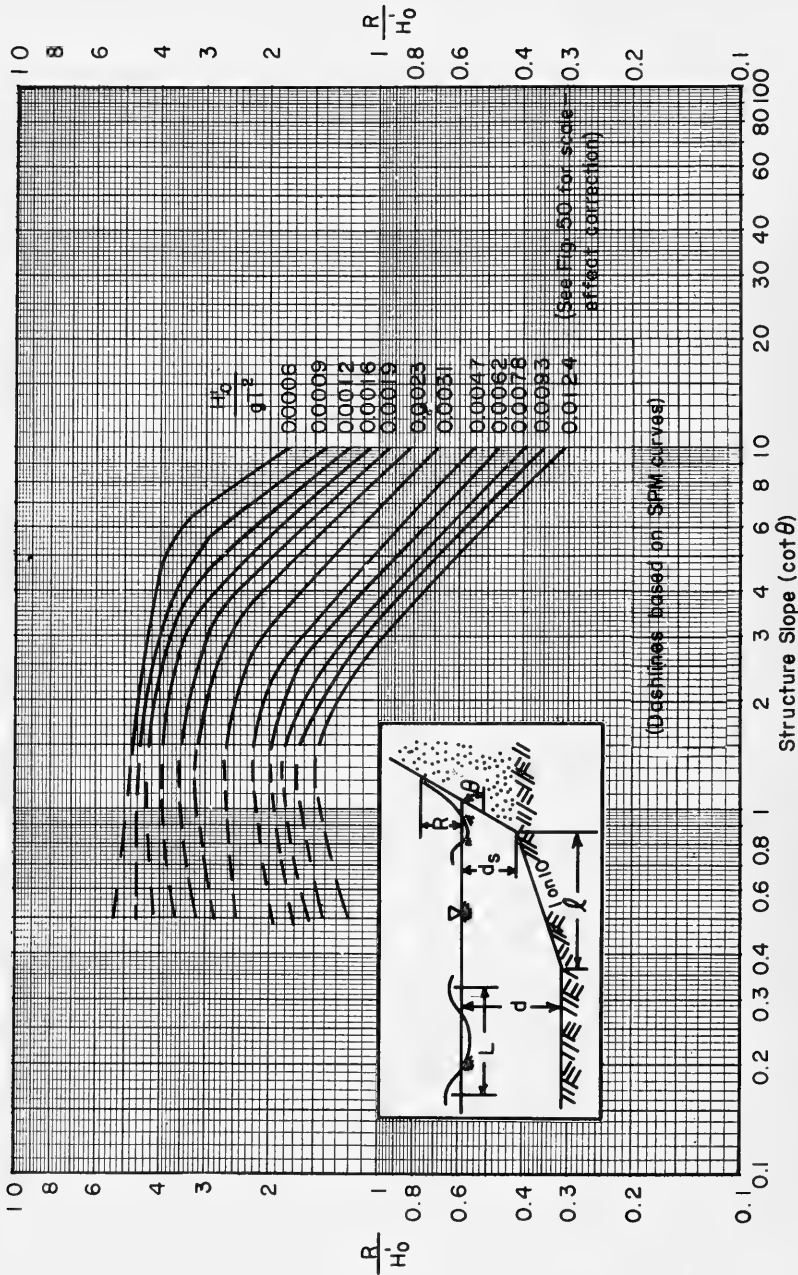

Figure 20. Relative runup for smooth slopes on 1 on 10 beach;  $\ell/L \geq 0.5$ ;  $d_s/H_0' = 0.6$ .

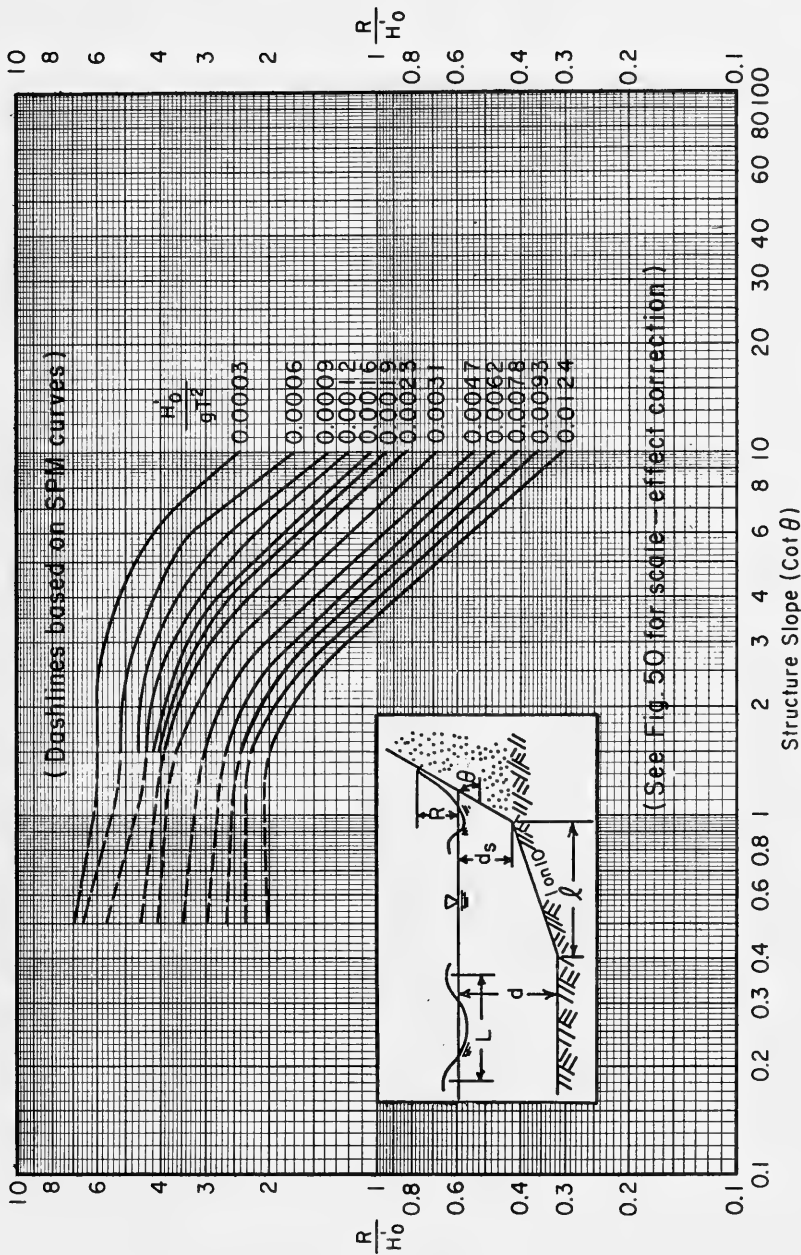

Figure 21. Relative runup for smooth slopes on 1 on 10 beach;  $l/L \geq 0.5$ ;  $d_g/H_0^1 = 1.0$ .

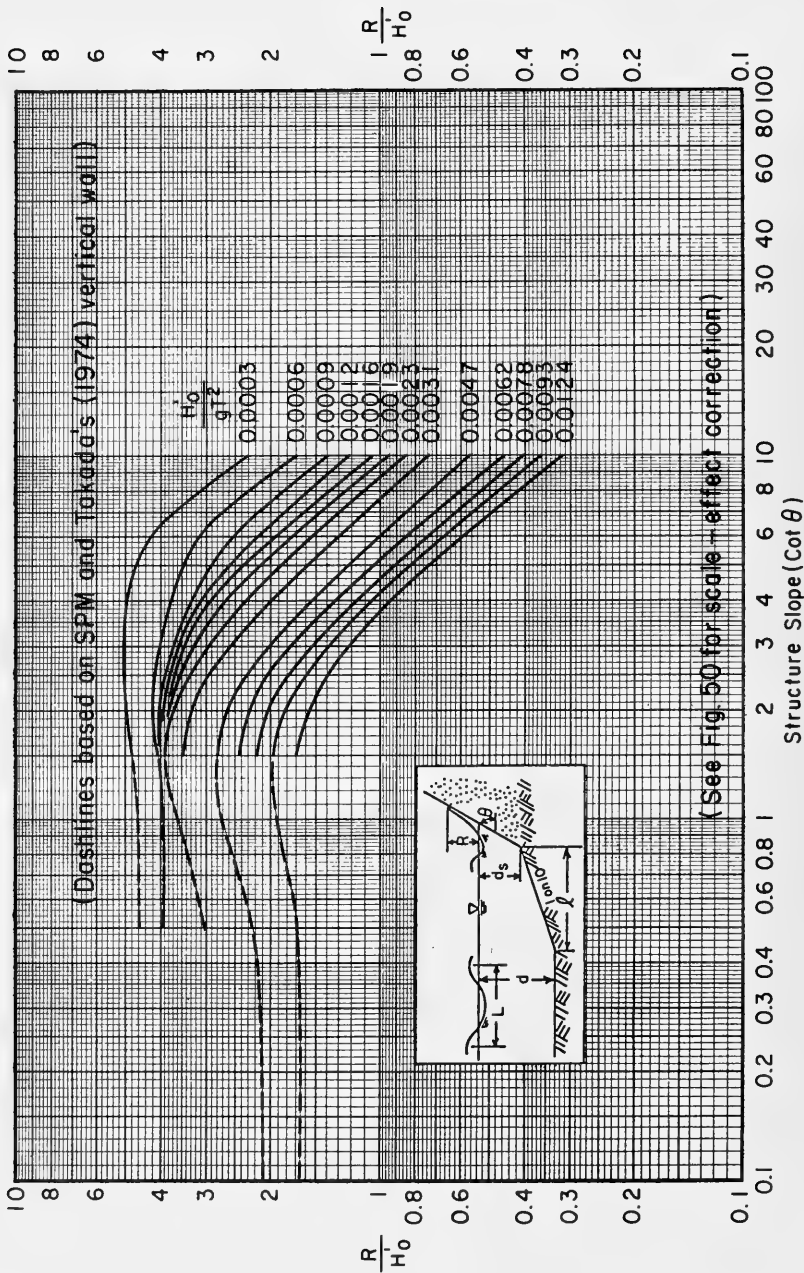

Figure 22. Relative runup for smooth slopes on 1 on 10 beach;  $\ell/L \geq 0.5$ ;  $d_g/H_0' = 1.5$ .

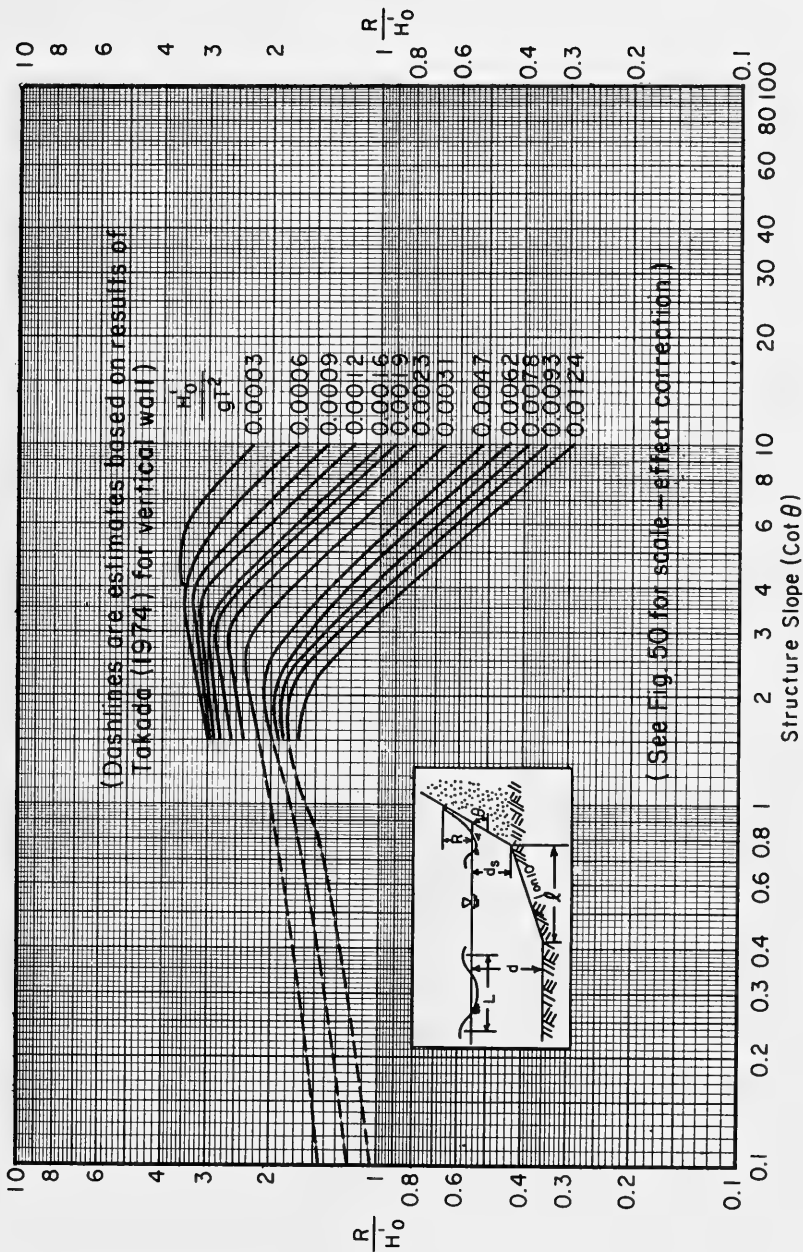

Figure 23. Relative runup for smooth slopes on 1 on 10 beach;  $l/L \geq 0.5$ ;  $d_g/H_0 = 3.0$ .

The experiments used two different toe depths,  $d_s = 0.058$  and  $0.116$  meter ( $0.19$  and  $0.38$  foot), and a uniform water depth,  $d = 0.381$  meter ( $1.25$  foot), seaward of the beach slope, resulting in corresponding changes in the horizontal length of beach slope,  $\ell$ . Relative runup differences might be expected for tests having different  $\ell/L$  values but the same incident wave characteristics ( $H'_0/gT^2$  and  $d_s/H'_0$ ); however, negligible differences were observed for cases of  $\ell/L > 0.5$ . Conditions of  $\ell/L < 0.5$  occurred only for the longer wave periods which also had low wave steepnesses ( $H'_0/gT^2 < 0.001$ , approximately). For these conditions, relative runup was higher rather consistently for the smaller values of  $\ell/L$ . The tests did not have a sufficient range of conditions to further define the effects of varying relative beach slopes. To further confuse the question, however, tests of different  $\ell/L$  values but equal  $H'_0/gT^2$  and  $d_s/H'_0$  values would be expected to include, because of the differing toe depths ( $d_s$ ), scale effects which cannot be isolated from apparent beach-slope effects.

Use of Figures 20 to 23 should be limited principally to conditions where  $\ell/L > 0.5$ . This particular value is somewhat arbitrary, but seems justified on the basis of the limited testing. For values of  $\ell/L < 0.5$ , but high  $d_s/H'_0$  (e.g.,  $d_s/H'_0 \geq 3.0$ ), the runup values from Figures 14, 15, and 16 for structures on horizontal bottoms should be used as upper bounds of relative runup on structures fronted by a 1 on 10 slope with the same  $d_s/H'_0$  value. In the case of  $\ell/L < 0.5$  with low values of  $d_s/H'_0$  (e.g.,  $0.6, 1.0$ , etc.), it should be expected that relative runup will be somewhat higher than predicted from the curves (Figs. 20 to 23), and probably not exceeding 15 to 20 percent higher. The effect of beach-slope length diminishes as the structure slope decreases, and effectively ceases to be significant for  $\cot \theta \geq 4.0$ .

e. Example Problems. Problems may be solved in part by use of equation (2) together with equation (1), or by use of Tables C-1 or C-2 in the SPM.

\* \* \* \* \* EXAMPLE PROBLEM 4 \* \* \* \* \*

GIVEN: An impermeable structure has a smooth slope of 1 on 3 and is subjected to a design wave,  $H = 2.5$  meters ( $8.2$  feet), measured at a gage located in a depth,  $d = 10.0$  meters. Design wave period is  $T = 8.0$  seconds. The structure is fronted by a 1 on 90 bottom slope, which extends seaward beyond the point of wave measurement. Design depth at structure toe is  $d_s = 7.5$  meters ( $24.6$  feet). (Assume no wave refraction between the wave gage and structure.)

FIND: Determine the height above SWL to which the structure must be built to prevent overtopping by the design wave.

SOLUTION: The wave height must be converted to a deepwater value.  
Using the depth where wave height was measured, calculate

$$\frac{d}{L_0} = \frac{d}{gT^2/2\pi} = \frac{d}{9.8 T^2/2\pi} = \frac{10}{1.56(8)^2}$$

$$\frac{d}{L_0} = 0.1002 .$$

To determine the shoaling coefficient,  $H/H'_0$ , equation (2) can be used with  $d = 10.0$  meters together with the wavelength determined from equation (1). Alternatively, Table C-1 in the SPM may be used. For

$$\frac{d}{L_0} = 0.1002 ,$$

$$\frac{H}{H'_0} \approx 0.9325 ;$$

therefore,

$$H'_0 = \frac{H}{0.9325} = \frac{2.5}{0.9325}$$

$$H'_0 = 2.68 \text{ meters} .$$

Calculate, also,

$$\frac{H'_0}{gT^2} = \frac{2.68}{9.8(8)^2} = 0.00427 ,$$

and, for  $d_s = 7.5$  meters,

$$\frac{d_s}{H'_0} = \frac{7.5}{2.68} = 2.8 .$$

The bottom slope is very gentle (1 on 90). Assuming that the slope approximates a horizontal bottom, the appropriate set of curves for  $d_s/H'_0 = 2.8$  is in Figure 14 (for  $d_s/H'_0 = 3.0$ ). For a 1 on 3 structure slope and

$$\frac{H'_0}{gT^2} = 0.00427, \quad \frac{R}{H'_0} = 2.0 .$$

The runup, uncorrected for scale effects, is

$$\begin{aligned} R &= (2.0)(H_0^1) \\ &= (2.0)(2.68) \\ R &= 5.4 \text{ meters (17.7 feet)}. \end{aligned}$$

The scale correction factor,  $k$ , is discussed in Section VI.

Alternatively, use of Figure 6 together with equation (8) gives a value of  $R/H_0^1 = 1.97$ , which is essentially the value determined from Figure 14.

\*\*\*\*\*  
\*\*\*\*\* EXAMPLE PROBLEM 5 \*\*\*\*\*

GIVEN: An impermeable smooth 1 on 2 structure is fronted by a 1 on 10 beach slope. Toe depth for the structure is  $d_s = 3.0$  meters (9.8 feet), but the beach slope extends seaward to a depth of 15.0 meters (49.2 feet), beyond which the slope is approximately 1 on 100. The design wave approaches normal to the structure and has a height of  $H = 2.8$  meters (9.2 feet) and period of  $T = 9.0$  seconds, measured at a depth of 16.0 meters (52.5 feet).

FIND: Determine the height of wave runup using the appropriate set of curves given in Section V,1.

SOLUTION: The wave height given is not the deepwater wave height; it is measured, however, above the gentle 1 on 100 bottom slope which approximates a horizontal surface. To determine the shoaling coefficient,  $K_s$ , for the location of measurement, calculate

$$\begin{aligned} \frac{d}{L_0} &= \left( \frac{d}{gT^2} \right) (2\pi) \\ &= \frac{16}{(9.8)(9)^2} (2\pi) \\ &= (0.02016)(6.283) \\ \frac{d}{L_0} &= 0.12667. \end{aligned}$$



From Table C-1 in the SPM,

$$K_s = \frac{H}{H'_O} \approx 0.9180$$

$$H'_O = \frac{H}{K_s} = \frac{2.8}{0.9180} = 3.05 \text{ meters (10.0 feet)}$$

$$\frac{d_s}{H'_O} = \frac{3.0}{3.05} = 0.984 \approx 1.0$$

$$\frac{H'_O}{gT^2} = \frac{3.05}{(9.8)(9)^2} = 0.00384.$$

Relative runup is determined from the appropriate set of curves; for a structure located on a 1 on 10 beach with  $d_s/H'_O = 1.0$ , use Figure 21. The value of  $\ell/L$  must then be determined.

$$\ell = (15 - 3)(10) = 120 \text{ meters (393.7 feet)}.$$

Next, determine the wavelength in water depth of 15.0 meters (the depth at the toe of the 1 on 10 slope). For

$$\frac{d}{L_O} = \frac{(15)(2\pi)}{(9.8)(9)^2} = 0.1187,$$

and from Table C-1,

$$\frac{d}{L} \approx 0.1570;$$

therefore,

$$L = \frac{d}{d/L} = \frac{15}{0.1570} = 95.54 \text{ meters (313.5 feet)}.$$

Then,

$$\frac{\ell}{L} = \frac{120}{95.5} = 1.26$$

thus,

$$\frac{\ell}{L} > 0.5 ,$$

and from Figure 21, for

$$\frac{H'_0}{gT^2} = 0.0038 ,$$

$$\frac{R}{H'_0} \approx 3.0 .$$

The runup is

$$R = \left( \frac{R}{H'_0} \right) (H'_0) = (3.0)(3.05)$$

$$R = 9.15 \text{ meters (30.0 feet) .}$$

(See Sec. VI for the appropriate scale-effect correction factor.)

\*\*\*\*\*

\*\*\*\*\* EXAMPLE PROBLEM 6 \*\*\*\*\*

GIVEN: Conditions are similar to example problem 5 with one exception.

An impermeable, smooth, 1 on 2 structure is fronted by a 1 on 10 beach slope. The beach slope extends seaward to a depth of 15.0 meters beyond which the slope is approximately 1 on 100. The design wave approaches normal to the structure, and has a height of  $H = 2.8$  meters and period of  $T = 9.0$  seconds, measured at a depth of 16 meters. The exception is that the structure is located at the waterline; i.e.,  $d_s = 0$ .

FIND: Determine the height of wave runup.

SOLUTION: From example problem 5,

$$H'_0 = 3.05 \text{ meters}$$

$$\frac{H'_0}{gT^2} = 0.00384 .$$

However,  $d_s = 0$ ;  $d_s/H'_0 = 0$ . To enable determination of runup, the depth at the toe of the beach slope ( $d = 15.0$  meters) is used.

$$\frac{d}{H'_0} = \frac{15}{3.05} = 4.92 \approx 5.0 .$$

Because the slope length is longer than in example problem 5, i.e.,  $\ell = (15-0) \cdot 10 = 150.0$  meters (492.0 feet), then

$$\frac{\ell}{L} > 0.5 .$$

From Figure 18 for  $d/H'_0 = 5$  and  $H'_0/gT^2 = 0.0038$ ,

$$\frac{R}{H'_0} \approx 1.2$$

$$R = \left(\frac{R}{H'_0}\right) (H'_0) = (1.2)(3.05) = 3.66 \text{ meters (12.0 feet).}$$

(See Sec. VI for the appropriate scale-effect correction factor.)

\*\*\*\*\*  
\*\*\*\*\* EXAMPLE PROBLEM 7 \*\*\*\*\*

GIVEN: A structure is designed geometrically similar to that in example problem 5, where an impermeable, smooth, 1 on 2 structure is fronted by a 1 on 10 beach slope. Toe depth for the structure is  $d_s = 3.0$  meters but the beach slope extends seaward to a depth of 15.0 meters beyond which the slope is approximately 1 on 100. However, a range of wave periods and deepwater wave heights are known;

$$H'_0 \leq 5.0 \text{ meters (16.4 feet).}$$

FIND: Determine maximum runup for three different wave conditions:  $T_{max} = 7.0$  seconds;  $T_{max} = 13.0$  seconds; and constant wave steepness,  $H'_0/gT^2 = 0.0104$ , with  $T_{max} = 7.0$  seconds.

SOLUTION: For any given  $d_s/H'_0$  value, the design curves show that relative runup is highest for the longest wave period (or the lowest wave steepness,  $H'_0/gT^2$ ). However, for constant toe depth,  $d_s$ , and for constant wave steepness, the largest wave height (or lowest  $d_s/H'_0$  value) usually results in the largest absolute runup, R. When a sloping beach is present and wave steepness varies, with depth held constant, the maximum runup may occur at a  $d_s/H'_0$  value other than the minimum. Thus, runup for a range of  $d_s/H'_0$  values should be investigated for this example problem.

(a) For the first condition where  $T_{max} = 7.0$  seconds, the maximum wave height given is  $H'_0 = 5.0$  meters; for this location, the resultant  $d_s/H'_0$  value is

$$\frac{d_s}{H'_0} = \frac{3}{5} = 0.6,$$

which corresponds to the lowest value given in Figures 20 to 23. The maximum runup may be determined by constructing a table for varying conditions. Because the maximum wave period is less here than in example problem 5, L is also less; thus,  $\ell/L > 0.5$  and Figures 20 to 23 may be used. For  $d_s = 3.0$  meters,  $T = 7.0$  seconds, and  $gT^2 = 480.20$  meters (1,576.0 feet), Table 3 may be constructed

where  $T$  is held constant at 7.0 seconds because the maximum wave period results in the highest relative runoff for each value of  $d_s/H'_0$ . The maximum runoff of 7.05 meters (Table 3) does not occur for the largest wave height since the largest waves break seaward of the structure for the given wave period.

Table 3. Example runoff for  $T = 7$  seconds, constant depth, and  $(H'_0)_{max} = 5.0$  meters.

Fig.	$\frac{d_s}{H'_0}$ <sup>1</sup>	$H'_0$ (m)	$\frac{H'_0}{gT^2}$	$\frac{R}{H'_0}$ <sup>2</sup>	R (m)
20	0.6	5.0	0.01041	1.35	6.75
21	1.0	3.0	0.00625	2.35	7.05 <sup>3</sup>
22	1.5	2.0	0.00416	2.8	5.6
23	3.0	1.0	0.00208	2.6	2.6

<sup>1</sup> $d_s/H'_0$  values selected to correspond with values in figures;  $d_s = 3.0$  meters.

$$^2 \cot \theta = 2.0.$$

$$^3 R_{max} = 7.05 \text{ meters.}$$

(b) For the second condition where  $T_{max} = 13.0$  seconds, the maximum runoff would occur for the lowest  $d_s/H'_0$  value. To check  $\ell/L$ , for  $d = 15.0$  meters:

$$\frac{d}{L_0} = \frac{15(2)(\pi)}{(9.8)(13)^2} = 0.057$$

$$\frac{d}{L} = 0.1013$$

$$L = 148.1 \text{ meters;}$$

$$\frac{\ell}{L} = \frac{120}{148.1} = 0.81 > 0.5 .$$

Table 4 may be constructed for  $d_s = 3.0$  meters,  $T = 13.0$  seconds,  $gT^2 = 1,656.20$  meters (5,434 feet) and using Figures 20 to 23. Table 4 shows that, in this case, not only is the runoff higher for the longer wave period, but the maximum runoff occurs at a lower  $d_s/H'_0$  value for the maximum deepwater wave height.

(c) For the third condition, suppose that wave steepness is expected to be most important, and that the structure is being designed for a constant wave steepness of  $H'_0/gT^2 = 0.0104$  and a maximum period of 7.0 seconds.

Table 4. Example runup for  $T = 13$  seconds, constant depth, and  $(H'_0)_{max} = 5.0$  meters.

Fig.	$\frac{d_s}{H'_0}$ <sup>1</sup>	$H'_0$ (m)	$\frac{H'_0}{gT^2}$	$\frac{R}{H'_0}$ <sup>2</sup>	R (m)
20	0.6	5.0	0.00302	2.49	12.45 <sup>3</sup>
21	1.0	3.0	0.00181	3.80	11.40
22	1.5	2.0	0.00121	3.91	7.82
23	3.0	1.0	0.000604	3.15	3.15

<sup>1</sup> $d_s = 3.0$  meters.

<sup>2</sup> $\cot \theta = 2.0$ .

<sup>3</sup> $R_{max} = 12.45$  meters.

Table 5 shows the characteristic relationship that the largest runup,  $R$ , occurs for the lowest  $d_s/H'_0$  value when  $H'_0/gT^2$  and  $d_s$  are constant; however, the largest *relative* runup has lower dimensional runup. Furthermore, Table 5 does not indicate the maximum runup to be expected on this structure for the given conditions. Table 3 shows the maximum to be  $\approx 7.05$  meters for a maximum period of 7.0 seconds.

Table 5. Example runup for constant wave steepness,  $H'_0/gT^2 = 0.0104$ .

Fig.	$\frac{H'_0}{gT^2}$	$\frac{d_s}{H'_0}$ <sup>1</sup>	$H'_0$ (m)	T <sup>2</sup> (s)	$\frac{R}{H'_0}$ <sup>3</sup>	R (m)
20	0.0104	0.6	5.0	7.0	1.35	6.75 <sup>4</sup>
21	0.0104	1.0	3.0	5.42	1.88	5.64
22	0.0104	1.5	2.0	4.43	1.72	3.44
23	0.0104	3.0	1.0	3.13	1.69	1.69

<sup>1</sup> $d_s = 3.0$  meters.

<sup>2</sup> $T_{max} = 7.0$  seconds.

<sup>3</sup> $\cot \theta = 2.0$ .

<sup>4</sup> $R_{max} = 6.75$  meters.

Thus, care should be exercised in determining runup for a particular structure. The results of the three parts of this problem are summarized in Table 6. Scale-effect corrections applicable to this example problem are discussed in Section VI.

Table 6. Summary of maximum runup for different conditions.

Table	Wave condition	Maximum R (m)
3	Constant period; T = 7.0 seconds	7.05
4	Constant period; T = 13.0 seconds	12.45
5	Constant steepness: $H_o^3/gT^2 = 0.0104;$ $T_{max} = 7.0$ seconds	6.75

\*\*\*\*\*

## 2. Rubble Slopes.

Runup data for rubble slopes have traditionally been separated according to structure type, whether for rubble-mound structures or for riprap revetments. There is no essential difference between the two types of structures with respect to stone sizes. "Riprap" is commonly used for rubble protection of an embankment slope that is high relative to expected waves. "Rubble mound" is usually applied to structures such as breakwaters and jetties in which the top of a relatively impermeable core is at or near the SWL, and the part of the structure above the core is relatively permeable. The rubble-mound structure would be expected to absorb and transmit an appreciable amount of energy through the upper, permeable part of the structure.

Of the numerous tests conducted on rubble slopes, most have been principally studies of armor unit stability rather than wave runup. Most tests where runup data were obtained have been for rather limited wave conditions or structure geometry, and usually model specific conditions for a prototype installation.

Available runup data for rubble slopes may be divided between studies with quarystone and studies with concrete armor units. Quarystone dimensions used in this study are the median sieve size for small-scale laboratory tests (if given), or the calculated diameter of a sphere of weight equal to the median quarystone weight; i.e., the nominal diameter. No evaluation of grading (or sorting) of the armor stone sizes is attempted. However, most quarystone layers would be well sorted (poorly graded) but the degree of sorting is only a relative term--relative to another assortment of stones. A poorly sorted (well-graded) armor layer would have a large fraction of smaller rocks which could fit in the void spaces between larger stones and, therefore, reduce the cover layer permeability and roughness.

Concrete armor units are represented by a characteristic length discussed later in this section.

a. Quarystone Armor Units. Most of the available rubble-slope data apply to quarystone armor units. Other types of armor units

(generally precast concrete) have been tested extensively, but usually for stability purposes. Runup results for concrete units are discussed in Section V,2,b.

(1) Permeable Structures. Details of quarystone rubble-mound structures, for which data by various authors were reanalyzed, are given in Figure 24. Test conditions are given in Table 7.

Hudson (1958, 1959) tested a breakwater configuration using a wide range of slopes and wave conditions. The tests were done principally for one stone size, with a smaller stone tested for the 1 on 4 and 1 on 5 slopes. In the tests with the smaller stone, results for the 1 on 5 slope seemed to give anomalously high runup values, and are not discussed here.

The structure geometry used by Hudson (1958) is shown schematically in Figure 24. The core is below the SWL and its height-to-water depth ratio is approximately 0.75, with only armor stone above the top of the core. The structure slope used in analyzing the relative runup is the slope above the core level; below the top elevation of the core, the structure slope is steeper, being 1 on 2 for upper slopes of 1 on 3, 1 on 4, and 1 on 5 (see Fig. 24). The effects of this nonplanar slope on runup are unclear. Heights of waves breaking on the structure would certainly be modified (increased or decreased) relative to a planar slope, depending on the effects of the steepened structure on shoaling.

Runup curves based on data by Hudson (1958) are shown in Figures 25, 26, and 27. The points shown in the figures are not Hudson's data points but are values interpolated from his data for the particular wave conditions noted in each figure. The graphs are differentiated by relative depth,  $d_g/H'_0$ , and the corresponding relative stone size,  $H'_0/k_p$ , where  $k_p$  for stones is the nominal stone diameter.

Jackson (1968a) conducted limited tests on a rubble-mound breakwater using "rough" quarystone and also stone essentially the same as Hudson's (Jackson's "smooth" quarystone). Jackson's structure differed, however, in having a core slightly above the SWL (see Fig. 24). If the second underlayer is included in the core height (underlayer stone weight =  $W/200$ , where  $W$  is the armor stone weight) then the core height is approximately 1.1  $d_g$ , whereas Hudson's core height was  $\approx 0.75 d_g$ . Jackson's structure would be expected to reduce wave transmission with a consequent increase of both runup and reflection. This conclusion is supported by the available data; e.g., Jackson's runup data are approximately 8 percent higher than Hudson's for a 1 on 1.5 slope,  $d_g/H'_0 = 5.0$ . Figure 28 gives example runup curves derived from Jackson's data for smooth quarystone; the relative depth is  $d_g/H'_0 = 5.0$ .

Savage (1958, 1959) tested permeable slopes with relatively small diameter stones. His structures differed from Hudson's and Jackson's in that the stone "structure" was placed against the vertical tank wall. Wave transmission through the structure was not possible; therefore,

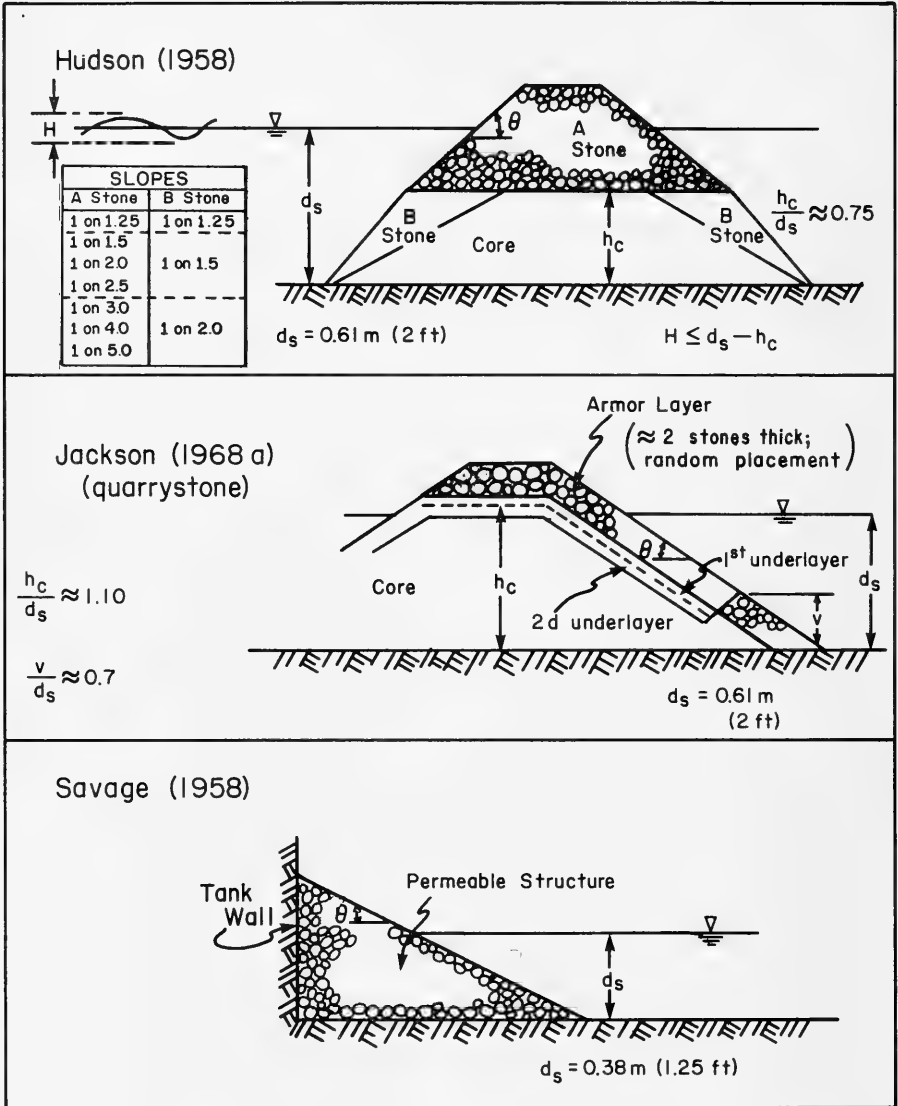

Figure 24. Permeable rubble-mound structures.



Table 7. Quarrystone rubble-mound runup test conditions.

Source	Structure slope (cot $\theta$ )	$\frac{d_g}{gT^2}$	$\frac{H_o^3}{gT^2}$	Stone diam toe depth or $k_{pr}/d_g$	Toe depth, $d_g$ m (ft)
Hudson (1958, 1959)	1.25, 1.5, 2.0, 2.5, 3.0, 4.0, 5.0	0.00884 to 0.0802	0.00044 to 0.02064	0.074 and 0.051	0.61 (2.0)
Jackson (1968a)	1.33, 1.75, 2.25	0.0088 0.0362 0.0634	0.0015 to 0.0022 0.006 to 0.010 0.010 to 0.017	0.0815 and 0.074	0.61 (2.0)
Savage (1958, 1959)	Vertical; 0.5, 1.0, 1.5, 2.25, 4.0, 6.0, 10.0, 30.0	0.00176 to 0.0749	0.000047 to 0.0155	0.00053 to 0.0263	0.38 (1.25)

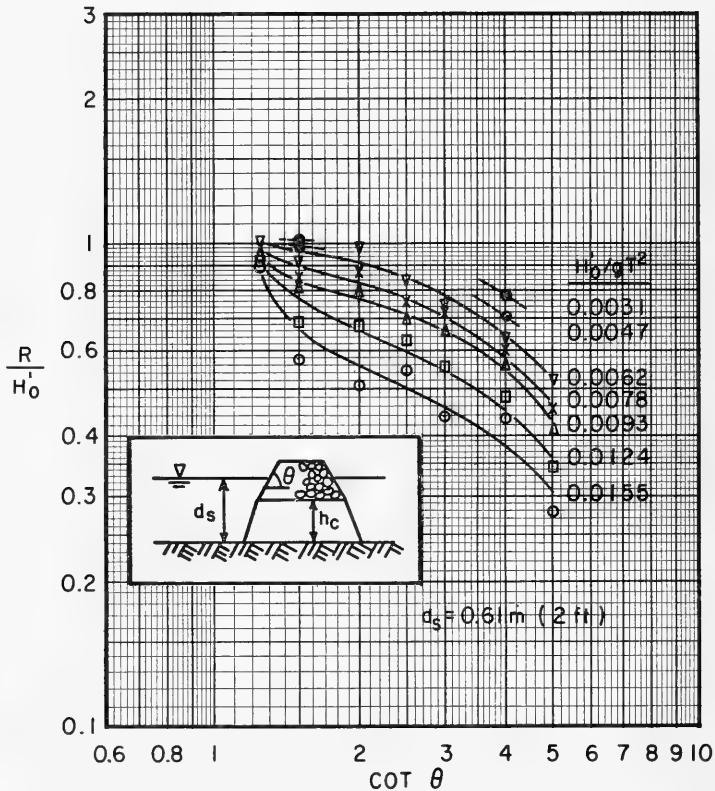

Figure 25. Quarrystone rubble-mound runup;  $d_s/H_0' = 3.0$ ;  
 $H_0'/k_r = 4.5$ ;  $h_c/d_s \approx 0.75$  (after Hudson, 1958).

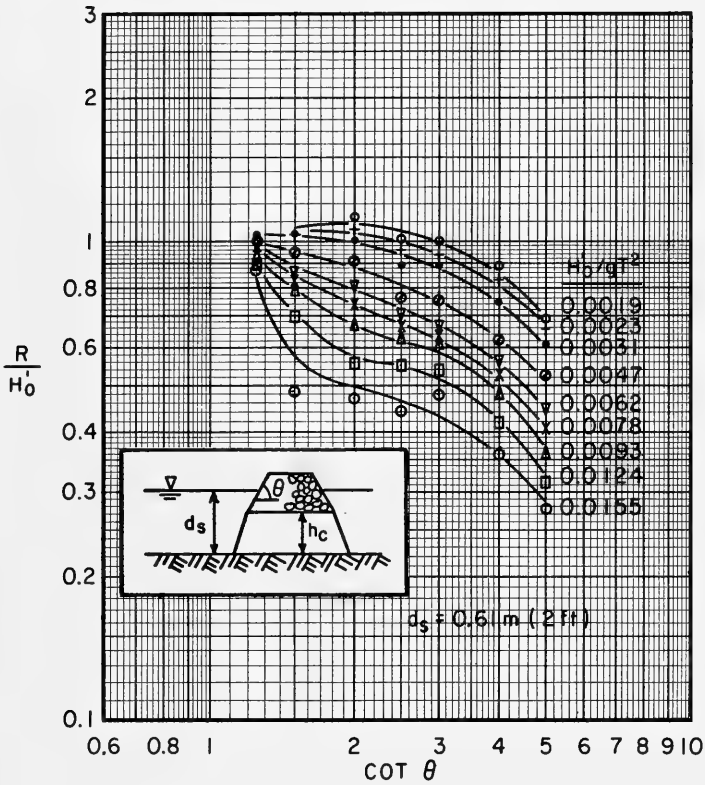

Figure 26. Quarystone rubble-mound runup;  $d_s/H_0' = 5.0$ ;  
 $H_0'/k_T = 2.7$ ;  $h_c/d_s \approx 0.75$  (after Hudson, 1958).

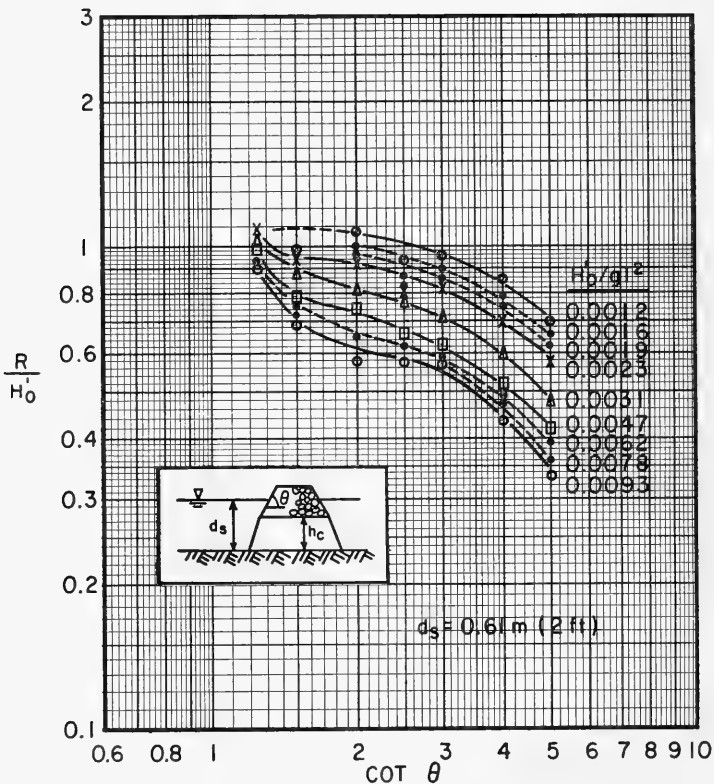

Figure 27. Quarystone rubble-mound runup;  $d_s/H_0' = 8.0$ ;  
 $H_0'/k_r = 1.7$ ;  $h_c/d_s \approx 0.75$  (after Hudson, 1958).

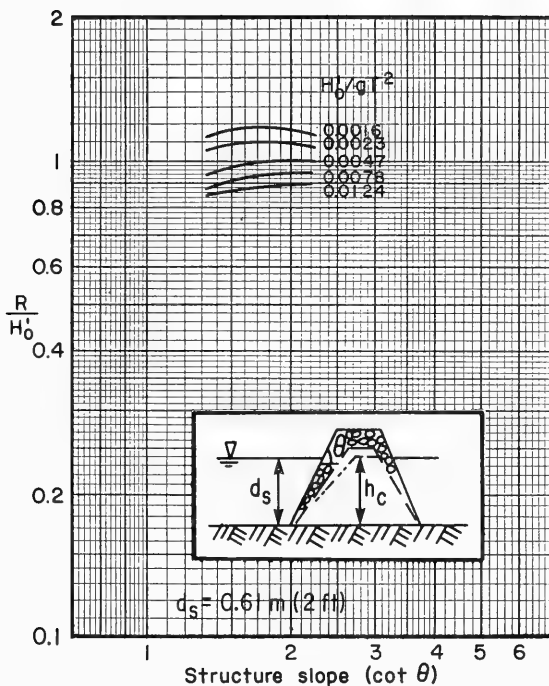

Figure 28. Quarrystone rubble-mound runup ("smooth" stones); random placement;  $d_s/H_0^1 = 5.0$ ;  $H_0^1/k_T = 2.7$ ;  $h_c/d_s \approx 1.10$  (after Jackson, 1968a).

reduction in runup would be a function of surface roughness, total void space, and friction effects within a porous medium. Runup curves derived from Savage's data are given in Figures 29 and 30. These curves are derived from data for the largest stone size, 10.0 millimeters, tested by Savage, and for which  $H'_0/k_p = 12.7$  and  $4.8$  for  $d_s/H'_0 = 3.0$  and  $8.0$ , respectively. His data for all stone sizes show that, for constant wave conditions ( $d_s/H'_0$  and  $H'_0/gT^2$ ), runup was higher on slopes having larger values of  $H'_0/k_p$  (i.e., smaller stones).

The structure used by Savage was actually intermediate between a permeable rubble mound and impermeable riprap. This structure could be considered to represent riprap with a thickness of many stones; however, this would be unusual because the riprap layer in prototype installations is generally only 2 to 4 stones thick. It could represent the use of stone in front of seawalls, a practice in some locations. Also, the tests are somewhat unrealistic in that the stone size is small relative to wave height and slope stability could have been a problem.

Direct comparison of the various rubble-slope runup data is difficult because relative stone sizes are not always the same for given wave conditions. Indirect comparisons can be made if the rubble-slope runup values are first calculated as fractions of smooth-slope values. Then, for a specific structure slope and cross section, wave steepness, and relative depth, effects of the relative roughness ( $H'_0/k_p$ ) may be evaluated.

The rubble-slope data have been evaluated in this manner using the appropriate smooth-slope curves given earlier. The ratio of rubble-slope relative runup to smooth-slope relative runup is designated  $r$ . For a given slope, relative depth ( $d_s/H'_0$ ), and relative roughness ( $H'_0/k_p$ ),  $r$  appeared to vary with wave steepness, as might be expected, but with no consistent trend. Therefore,  $r$  values for several wave steepnesses were averaged for constant relative depth, relative roughness, and slope. The  $r$  values based on data of Hudson (1958) and Savage (1959) are given in Figures 31 and 32. The horizontal axes are the relative roughness or relative stone size,  $H'_0/k_p$ . Each curve is based on  $r$  values averaged over a range of wave steepness for each relative stone size used in the analysis.

Hudson's data give rather low  $r$  values of 0.36 to 0.64. A positive slope trend in the data is noticed for the flatter structure slopes, and might be expected since the stone size becomes smaller relative to the wave as  $H'_0/k_p$  increases.

The  $r$  values for the quarystone rubble mound tested by Jackson (1968a) are given in Table 8. Jackson's data are for limited conditions;  $r$  values are 0.48 to 0.52, which are higher than Hudson's data for the given relative stone sizes. This result is expected because of the higher core in Jackson's tests.

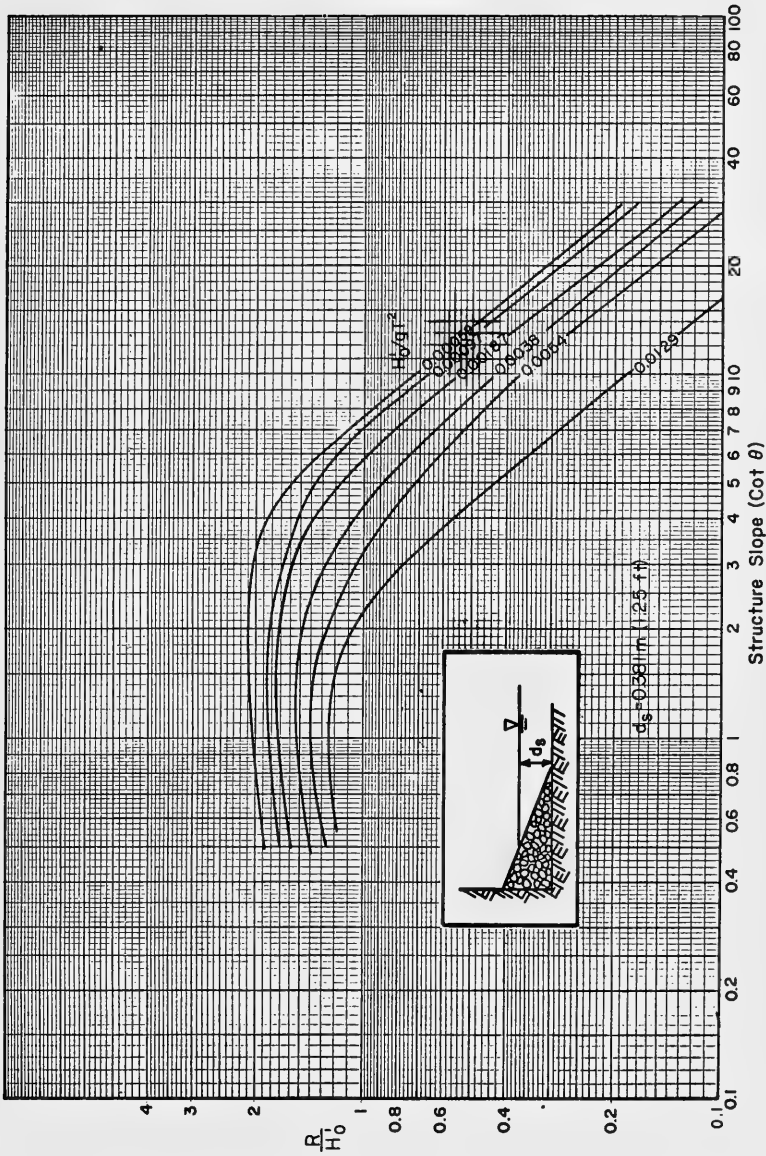

Figure 29. Runup on rubble slope;  $d_s/H_0^1 = 3.0$ ;  $H_0^1/k_r = 12.7$  (after Savage, 1959).

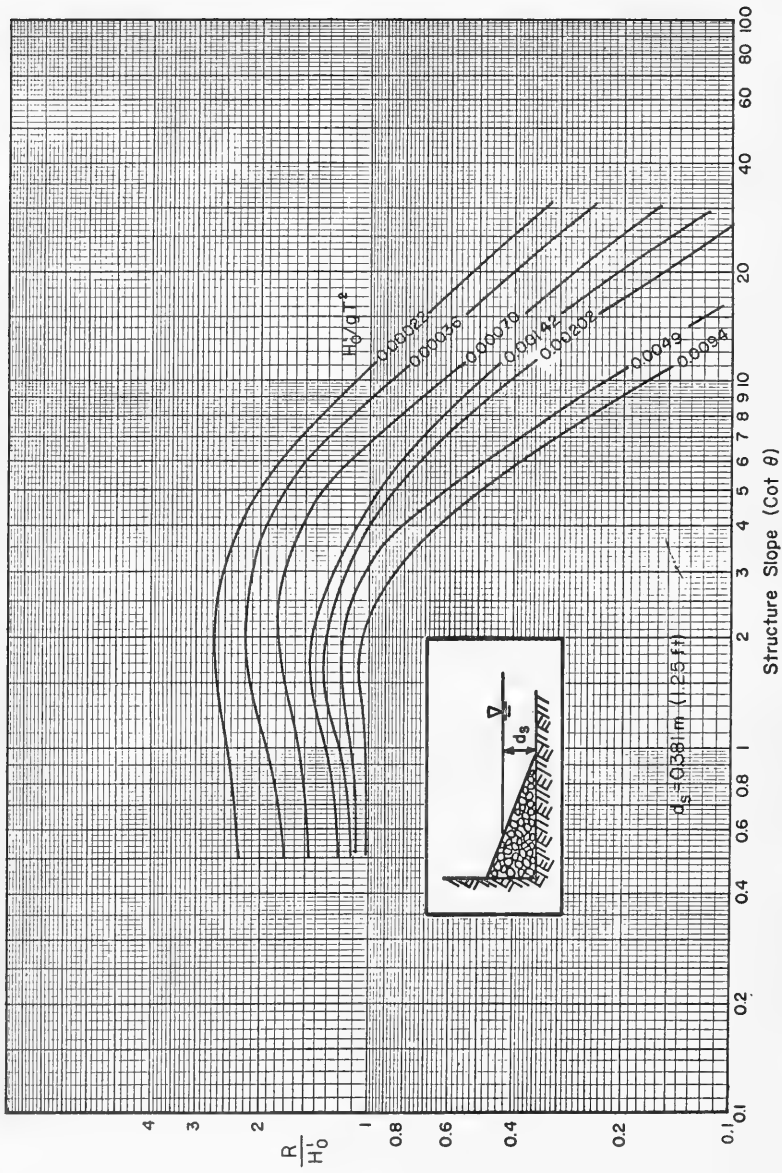

Figure 30. Runup on rubble slope;  $d_s/H_0 = 8.0$ ;  $H_0'/k_r = 4.8$  (after Savage, 1959).



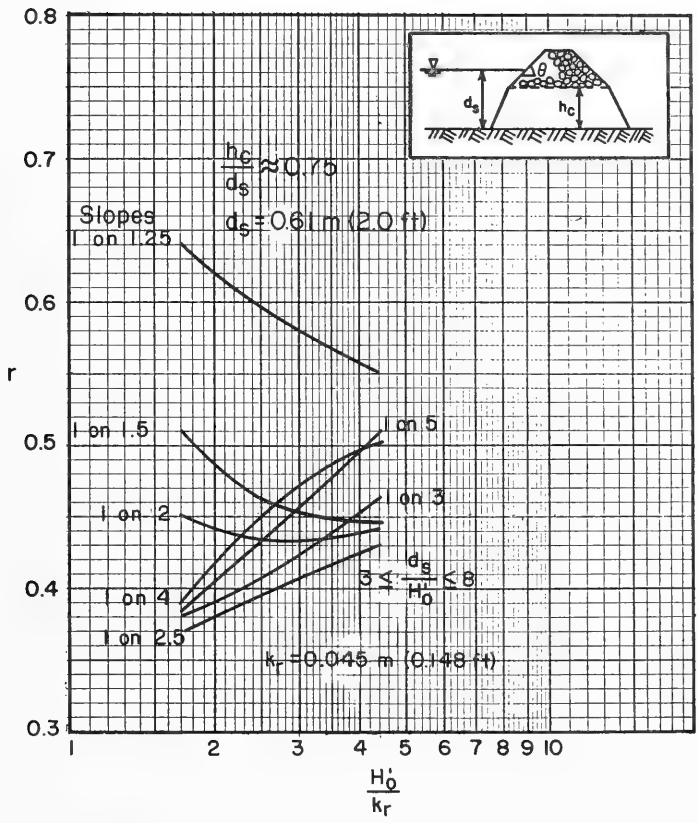

Figure 31. Values of  $r$  for slope and relative roughness ( $H_0'/k_r$ ) for permeable rubble mound (after Hudson, 1958).

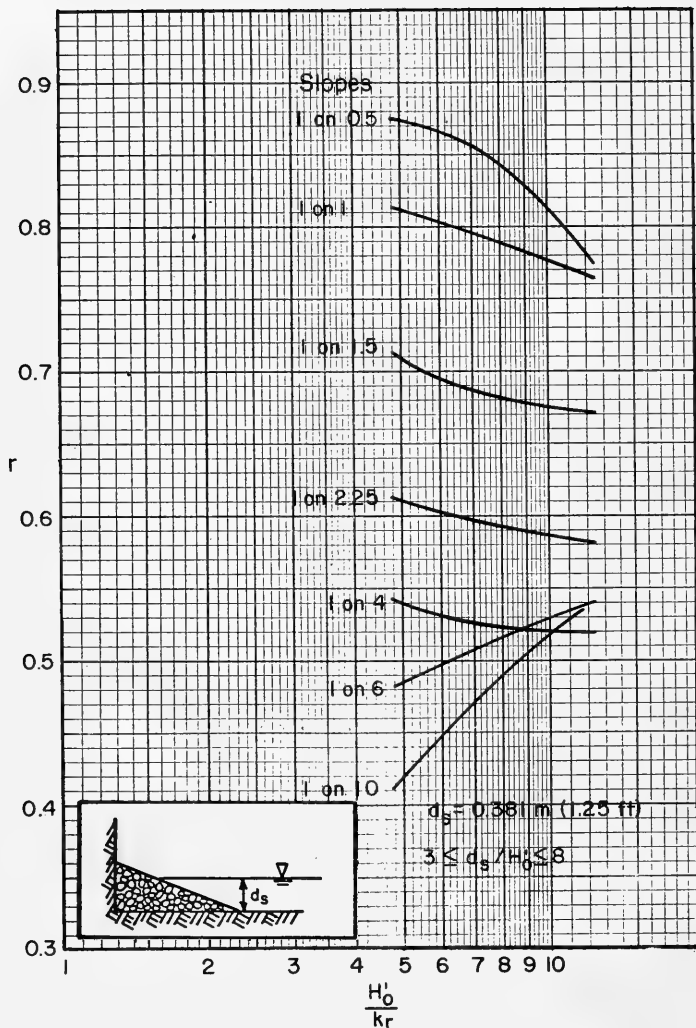

Figure 32. Values of  $r$  for slope and relative roughness ( $H'_0/k_r$ ) for permeable structure (after Savage, 1959).

Table 8. Values of  $r$  for a quarystone rubble mound (after Jackson, 1968a).

$d_s/H'_0$	$H'_0/k_n$	Slope (cot $\theta$ )	$r$
5.0	2.7	1.5 (interpolated) 2.25	0.52 0.51
5.0	2.45	1.5 (interpolated) 2.25	0.48 0.48

Savage's data have a rather wide range of  $r$  values, with the highest values for the steepest structure slopes. The observed runup values for the steep slopes are probably influenced by the rather short horizontal distance along the SWL between the vertical end wall and the structure slope. Flatter slopes have progressively smaller  $r$  values.

A reversal in trends of the plotted lines in Figures 31 and 32 may be a result of water particle motion differences for breaking and non-breaking waves (on the structure) and also of differences between standing wave and surging wave effects for varying structure slopes.

A value of  $r \approx 0.50$  to  $0.55$  appears conservative for a rubble-mound structure (such as that tested by Jackson, 1968a) with the top of the core approximately at the SWL. Lesser values of  $r$  appear justified, usually, for a structure with low core height, such as tested by Hudson (1958); a very steep structure slope (e.g., 1 on 1.25) may nevertheless have high  $r$  values. Variations in  $H'_0/k_n$  will also affect the selection of an  $r$  value. A porous structure with an impermeable backing, such as that used by Savage (1958), has considerable variance, with  $r$  values ranging from  $r \approx 0.87$  for a 1 on 0.5 slope to  $r \approx 0.4$  for a 1 on 10 slope.

(2) Impermeable Structures. Test conditions of quarystone revetment runup experiments discussed here are given in Table 9. Cross-sectional diagrams are shown in Figure 33.

Saville (1962) conducted runup tests in a large wave tank with a depth of 4.57 meters (Fig. 33). He tested riprap on a 1 on 1.5 slope sited on a horizontal tank bottom. Armor layers of both one- and three-stone thicknesses on a concrete slope were tested. Instability problems on an impermeable base would be appreciable, particularly for a layer one stone thick. Although Saville gives results for both armor unit conditions, only the results for the layer three stones thick are given here. Relative depth varied from approximately  $d_s/H'_0 = 5.0$  to  $d_s/H'_0 = 10.0$ , plus a few points at larger values; relative roughness or stone size varied from  $H'_0/k_n = 3.0$  (at  $d_s/H'_0 = 5.0$ ) to  $H'_0/k_n = 1.0$  (at  $d_s/H'_0 = 15.0$ ). Saville's data, when compared to the smooth-slope curves presented earlier, have values of  $r$  (averaged for several values of wave steepness) as given in Table 10.

Table 9. Quarrystone revetment runup tests.

Source	Structure slope (cot $\theta$ )	$\frac{d_s}{gT^2}$	$\frac{H_0'}{gT^2}$	Stone diam toe depth or, $k_p/d_s$	Toe depth, $d_s$ m (ft)
Saville (1962)	1.5	0.00182 to 0.0684	0.0001 to 0.014	0.067	4.57 (15.0)
Hudson and Jackson (1962)	2.0	0.01268 to 0.13803	0.00066 to 0.0166	0.038 to 0.0975	0.3 (1.0) 0.51 (1.67) 1.01 (3.33)
Palmer and Walker (1970)	3.0 (1 on 50 beach)	0.01268 to 0.069	0.00066 to 0.0158	0.0975	0.3 (1.0)
Raichlen and Hammack (1974)	1.5 (1 on 200 beach)	0.0004 to 0.015	0.000062 to 0.0124	0.222	0.3 (1.0)
Ahrens (1975a)	2.0 (1 on 200 beach)	0.00261 to 0.0621	0.0002 to 0.027	0.29	0.258 (0.846)
	2.5, 3.5, 5.0	0.00365 to 0.05942	0.00029 to 0.0137	0.045 to 0.074	4.57 (15.0)

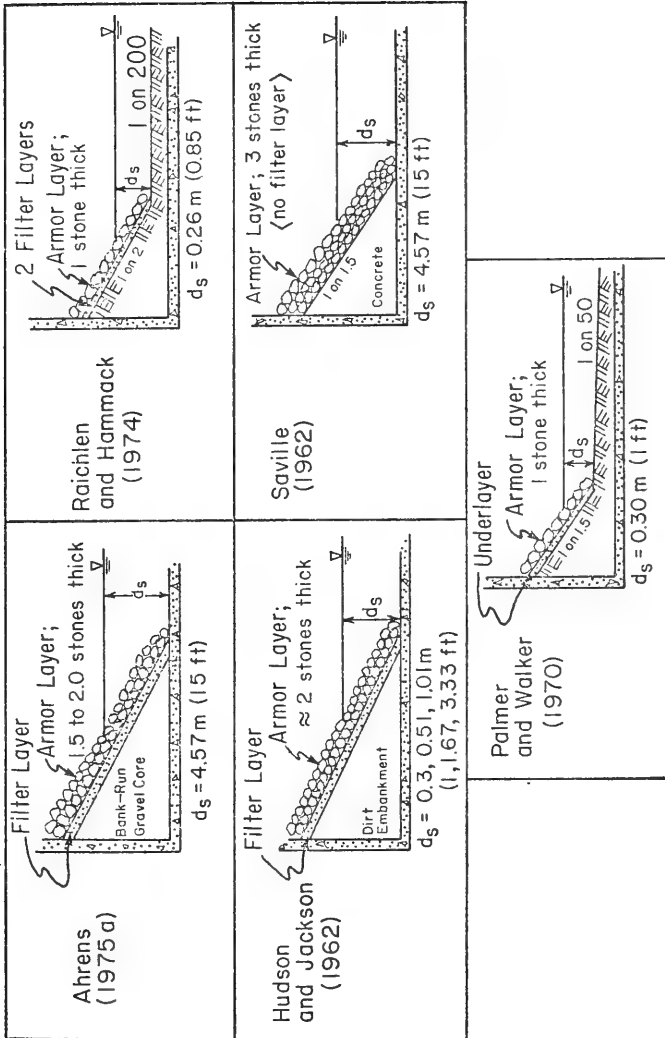

Figure 33. Impermeable structures.

Table 10. Values of  $r$  for quarystone riprap, 1 on 1.5 slope (armor layer three stones thick on impermeable base) (after Saville, 1962).

$d_s/H'_0$	$H'_0/k_p$	Slope (cot $\theta$ )	$r$
5.0	3.0	1.5	$\approx 0.6$
8.0	1.9	1.5	$\approx 0.625$

Hudson and Jackson (1962) tested riprap at small scales (Fig. 33) using two structure slopes, 1 on 2 and 1 on 3, both on a horizontal tank bottom. Although wave conditions were somewhat limited, a range of armor and underlayer stone sizes were tested. Runup curves based on these tests are given in Figure 34. The curve shapes are similar to those of the smooth-slope curves and to the rubble-mound curves.

Analysis of smooth-slope scale effects (see Sec. VI) indicates that scale effects between the various small-scale tests conducted by Hudson and Jackson (1962) would be negligible. Accordingly, the data were evaluated for stone-size effects combining all data from the various model scales. No clearly discernible trend in effects of stone size was found for the 1 on 2 slope; an  $r$  value of approximately 0.625 appears appropriate (Fig. 35) for the various  $H'_0/k_p$  values. However, the 1 on 3 slope shows increasing  $r$  values with increasing  $H'_0/k_p$  values (Fig. 35). The lines through the data in the figure are somewhat arbitrary, but the trends seem consistent with those in Figures 31 and 32.

Palmer and Walker (1970) tested runup on a 1 on 1.5 rubble slope on a 1 on 50 beach (Fig. 33), and gave their results in a set of curves using different variables than those in this study. Conversion of their results for selected data sets gives the points shown in Figure 36. Smooth-slope runup data for similar conditions are not available for comparisons. However, for larger  $d_s/H'_0$  values, runup values for a structure on a flat beach would be expected to be comparable to runup on the same structure sited on a 1 on 50 beach. Comparisons between Palmer and Walker's values and values for smooth structure slopes fronted by a horizontal beach give extremely low  $r$  values for the larger  $d_s/H'_0$  values ( $r \approx 0.38$  for  $d_s/H'_0 = 3.0$ ,  $H'_0/k_p \approx 1.5$  and  $r \approx 0.26$  for  $d_s/H'_0 = 5.0$ ,  $H'_0/k_p = 0.9$ ). It is unclear why the values are so low, but part of the reason may be in the difficulty of measuring runup on a slope with relatively large stones ( $H'_0/k_p$  small). Palmer and Walker's runup values for  $d_s/H'_0 = 1.5$ , when compared with runup values for a smooth structure slope fronted by a 1 on 10 beach, gave a value of  $r \approx 0.5$  for  $d_s/H'_0 = 1.5$  and  $H'_0/k_p \approx 2.9$ .

A useful aspect of Palmer and Walker's curves is that breaking conditions are given, where breaking is the depth-controlled condition; i.e., waves are breaking at or seaward of the toe of the structure.

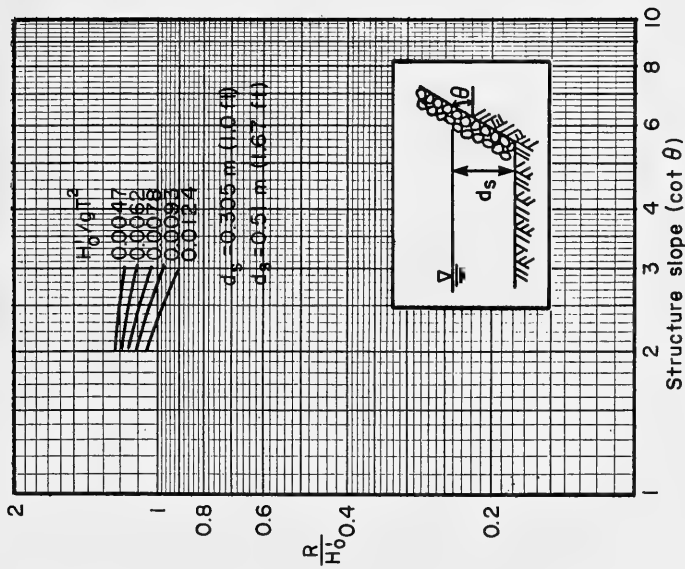

(a)  $d_s/H_0^L = 3$ ;  $H_0^L/K_{sP} = 3.4$  to  $3.8$ .

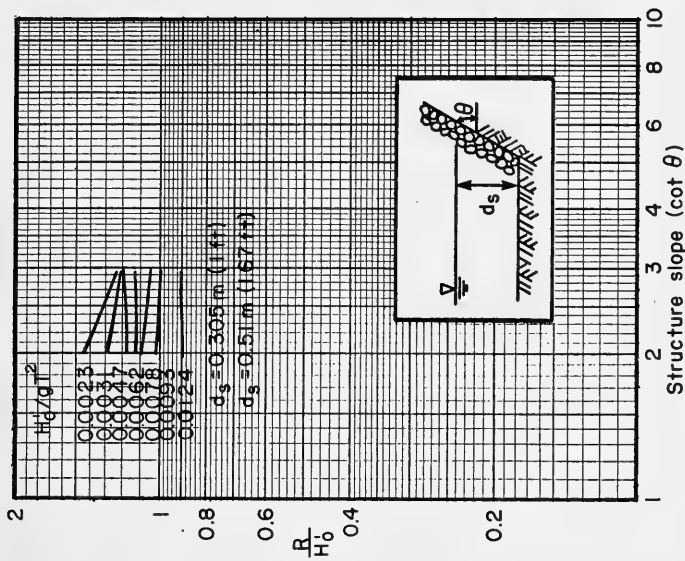

(b)  $d_s/H_0^L = 5$ ;  $H_0^L/K_{sP} = 2.05$  to  $2.61$ .

Figure 34. Runup for riprap slopes, approximately two layers (after Hudson and Jackson, 1962).

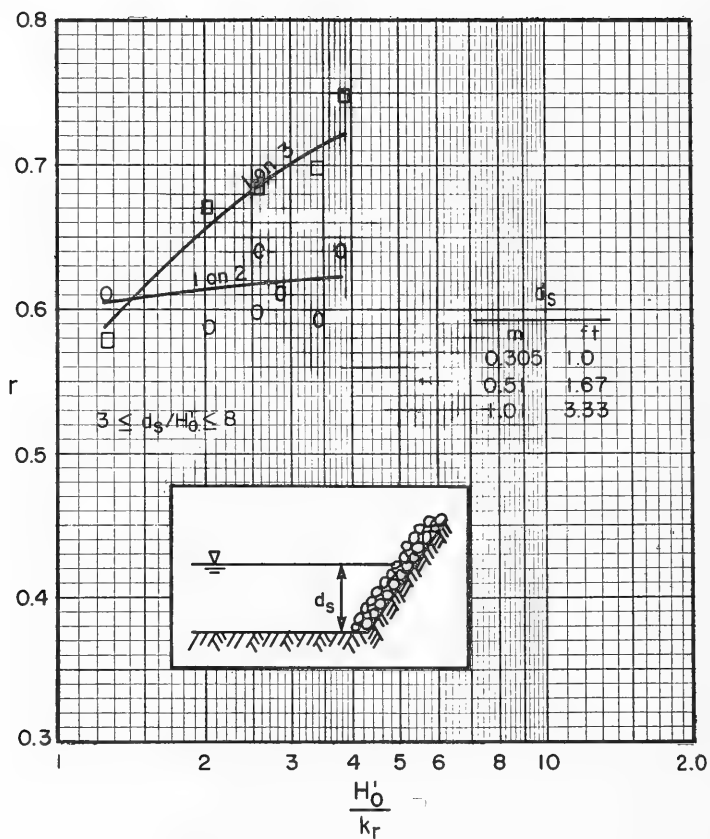

Figure 35. Values of  $r$  for slope and relative roughness ( $H_0^1/k_r$ ) for riprap slopes; armor layer approximately two stones thick (after Hudson and Jackson, 1962).



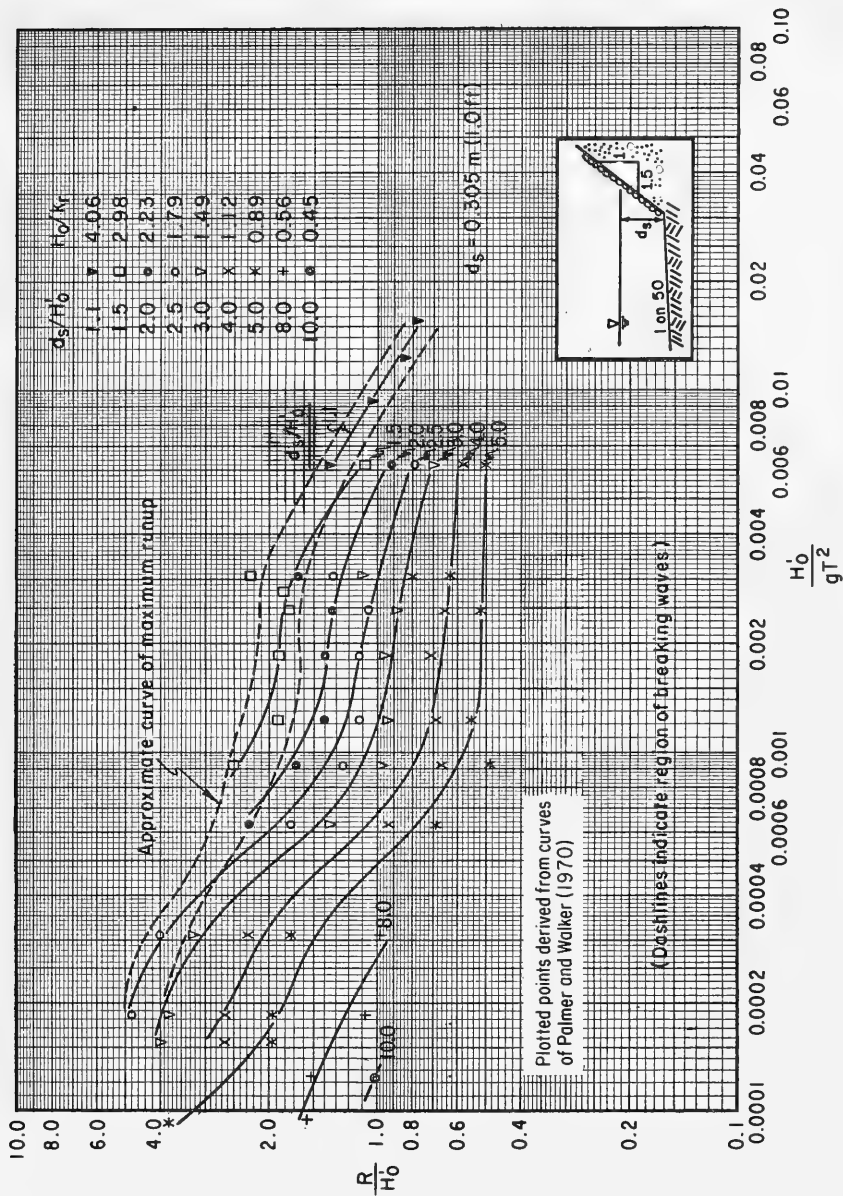

Figure 36. Runup curves for 1 on 1.5 riprap slope fronted by 1 on 50 bottom slope (derived from Palmer and Walker, 1970).

The crosshatched area in Figure 36 shows that, for a 1 on 1.5 rubble slope fronted by a 1 on 50 beach slope, the maximum absolute runup, coincident with breaking waves at or seaward of the structure toe, occurs for  $d_s/H'_0 \approx 1.0$  in the high wave steepness range ( $H'_0/gT^2$ ), but occurs for progressively higher  $d_s/H'_0$  values as  $H'_0/gT^2$  diminishes, to  $d_s/H'_0 \approx 2.6$  to 3.0 for  $H'_0/gT^2 \approx 0.0002$ .

Raichlen and Hammack (1974) tested structures with 1 on 2 slopes, having both rough (quarrystone armor) and smooth surfaces. The structures were fronted by a 1 on 200 beach slope (Fig. 33). Smooth-slope runup values from their curves were converted to the variables used in this study and are comparable to the smooth-slope runup values for a structure on a horizontal beach given in Figures 14, 15, and 16. Runup values of Raichlen and Hammack for the quarrystone rubble slope were also converted to variables in this study (Fig. 37), and were compared with their smooth-slope results. The various  $r$  values were each determined as an average of rough-slope runup to smooth-slope runup for varying wave steepness values but constant  $d_s/H'_0$  values. The resultant curve is given in Figure 38. The rather gentle negative slope of the line for the 1 on 2 structure presents a trend similar to that in Figures 31 and 32.

Ahrens (1975a; personal communication, 1975) tested riprap slopes (Fig. 33) in a wave tank with depth,  $d_s$ , of 4.57 meters. The armor layer was approximately 1.5 to 2 stones thick, with a filter underlayer lying on a core of bank-run gravel. Ahrens used various armor stone sizes, and for each slope and set of wave conditions, the larger  $H'_0/k_r$  values consistently had the higher values of relative runup. Figure 39 shows the effect of  $H'_0/k_r$  on relative runup for a range of wave steepnesses on a 1 on 3.5 slope for  $d_s/H'_0 = 7$ , as derived from Ahrens' data; Figures 40 and 41 show runup curves based on Ahrens' data for the specific conditions noted.

Ahrens' data were then compared to the data for smooth structure slopes fronted by a horizontal bottom and the resulting  $r$  values are given in Figure 42. Results of his runup data, which were obtained in large-scale testing, can be considered near-prototype scale. The  $r$  values were determined by comparison with small-scale smooth-slope test results. A difference in  $r$  values between large- and small-scale tests for rubble structures is not apparent. However, the smooth-slope runup curves are expected to underestimate prototype runup (see Sec. VI); therefore, application of the values in Figure 42 would give conservative results when used with appropriate smooth-slope values uncorrected for scale effects.

b. Concrete Armor Units. Concrete armor units have been developed primarily for increased stability under wave attack. In areas where rock is scarce or of insufficient size or quality, concrete armor units may become an economical necessity. Many types of armor units are available in sizes ranging from the 45-metric ton (50 tons) tribar

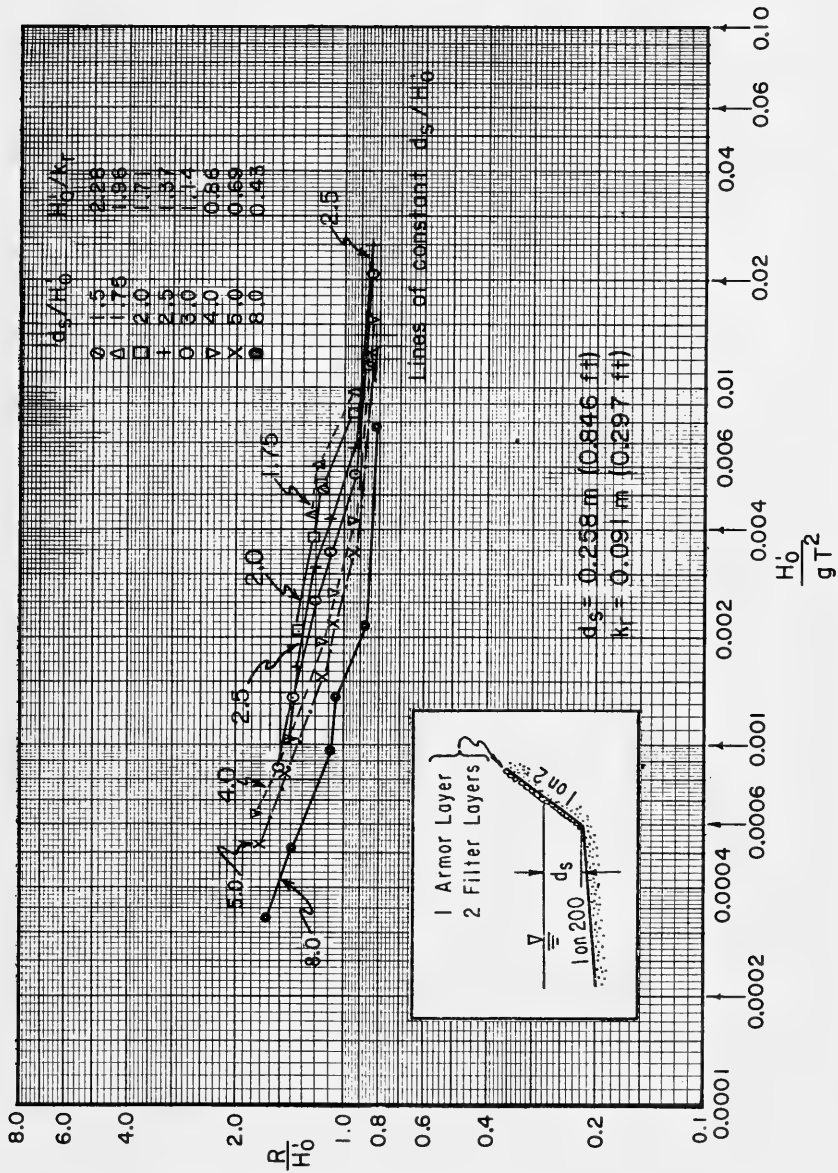

Figure 37. Relative runup for 1 on 200 slope fronted by 1 on 200 slope (curves derived from Raichlen and Hammack, 1974).

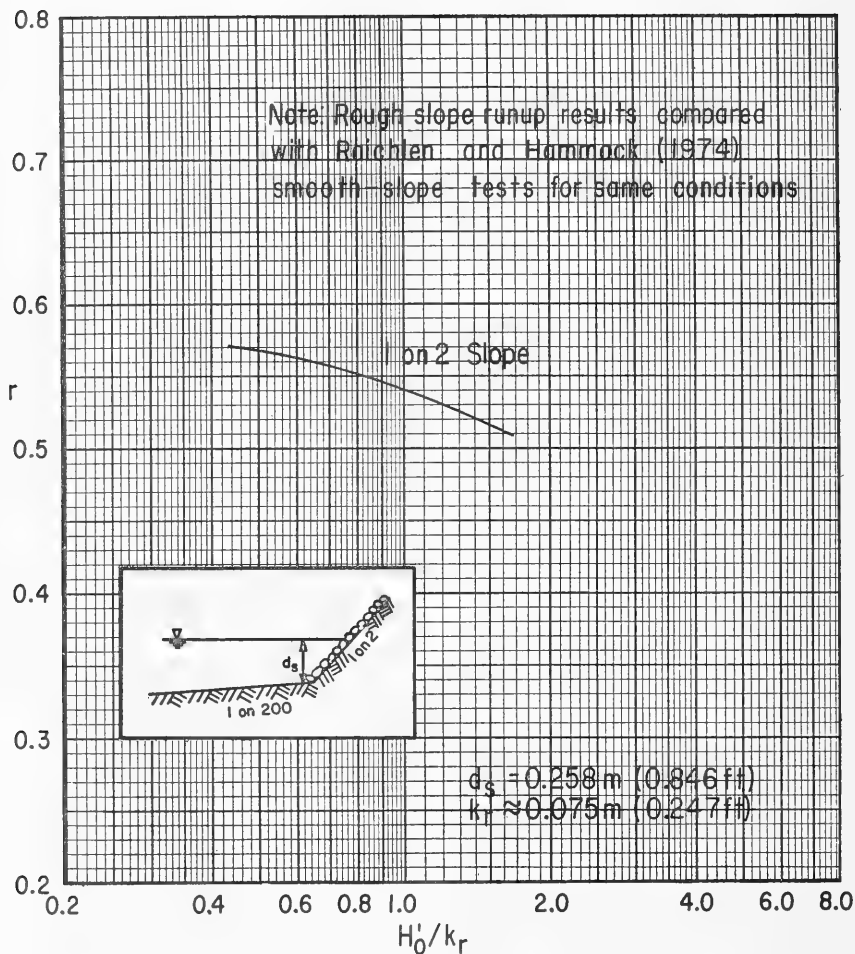

Figure 38. Values of  $r$  for relative roughness ( $H'_0/k_r$ ), for 1 on 2 riprap slope fronted by 1 on 200 slope (curve derived from Raichlen and Hannack, 1974).

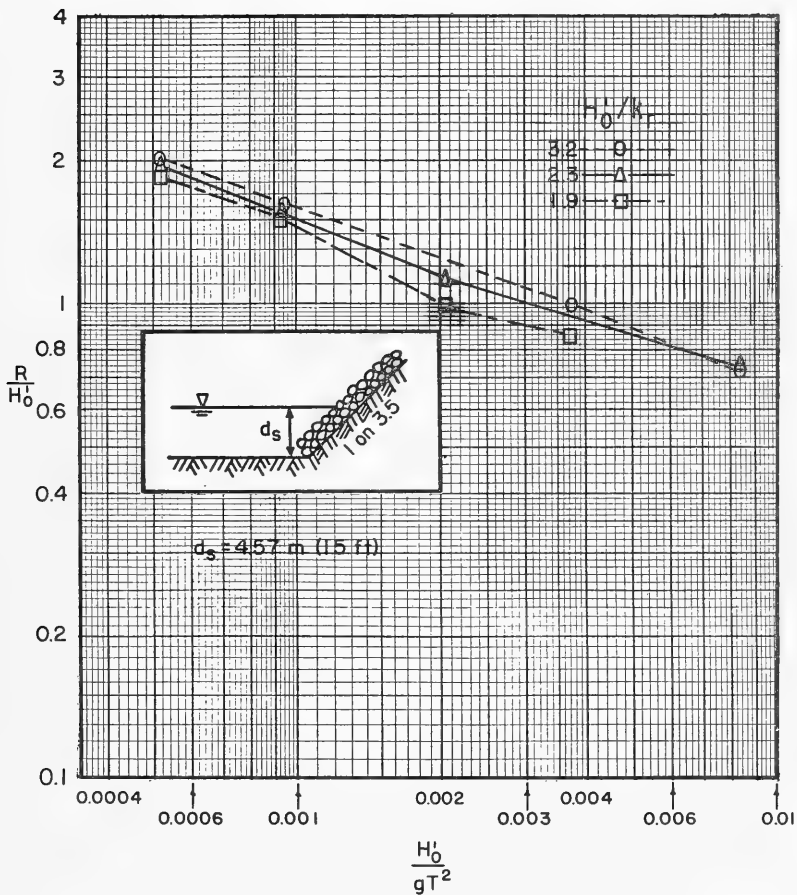

Figure 39. Example of runup for 1 on 3.5 riprap slope,  $d_s/H_0' = 7.0$ , for various relative stone sizes (after Ahrens, 1975a).

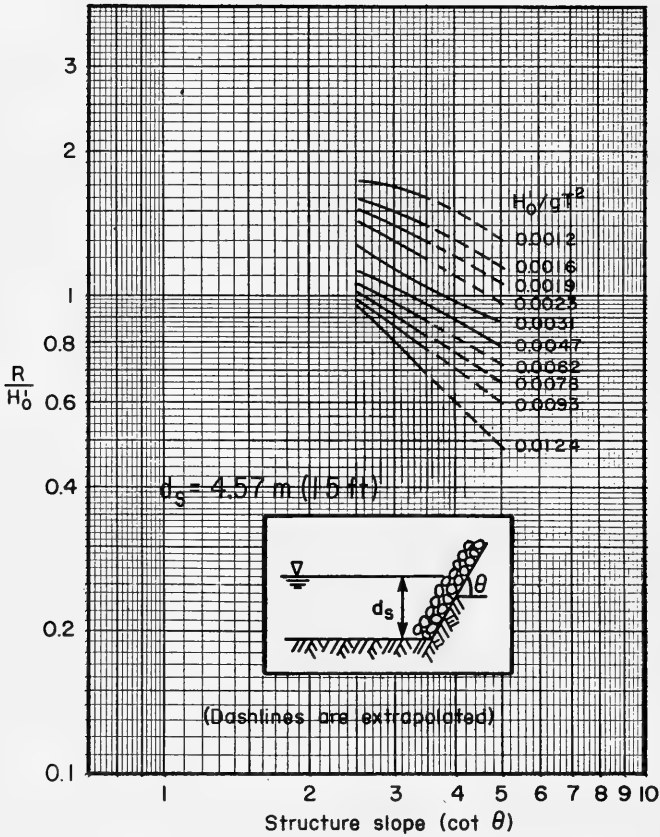

Figure 40. Relative runup for riprap slopes;  $d_s/H_0' = 5.0$ ;  $H_0'/k_r \approx 3.15$  (after Ahrens, 1975a).

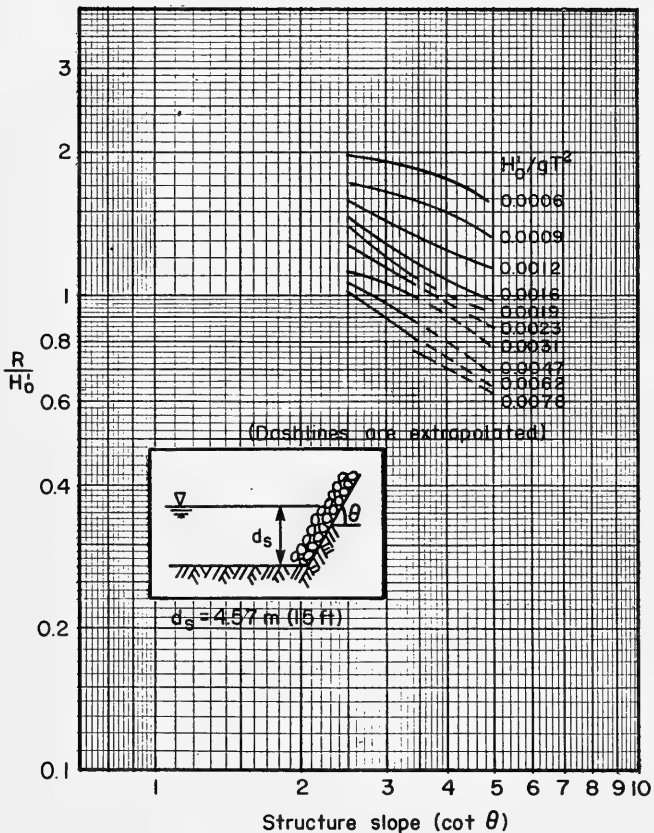

Figure 41. Relative runoff for riprap slopes;  
 $d_s/H_0' = 8.0$ ;  $H_0'/k_p = 2.8$   
 (after Ahrens, 1975a).

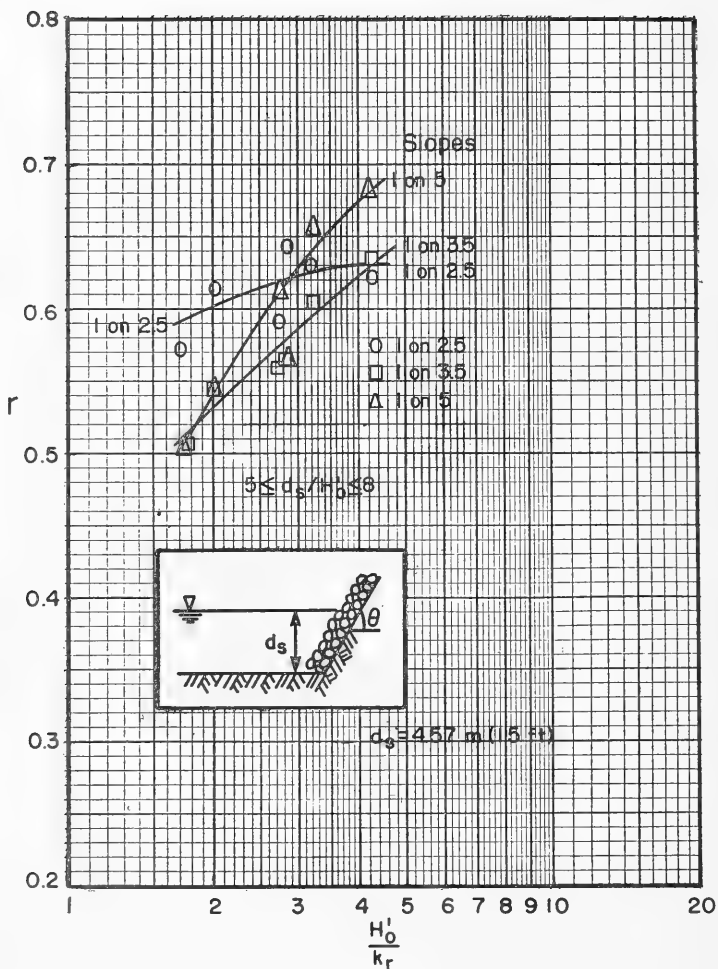

Figure 42. Values of  $r$  for riprap slope and relative roughness ( $H'_0/k_r$ ) (after Ahrens, 1975a).



(in Hawaii) to the 6.35-kilogram (14 pounds) Gobi block. Size can usually be adjusted according to need; type selection may depend on armor unit stability for a given structure. Stability coefficients are given in the SPM.

Concrete armor units have been tested and are used both for rubble-mound structures (usually porous near the top) and for riprap or revetment structures (usually impermeable to wave transmission). Most tests have been for permeable rubble-mound structures.

(1) Permeable Structures. Jackson (1968a) tested several armor units for runup and stability (Fig. 43). Further details of the armor units are given in the SPM or Hudson (1974). Wave conditions used in the tests were limited mostly to relative depths of  $d_s/H'_0 \approx 5.0$ . The relative armor size has been calculated for this study as  $H'_0/k_p$ , using, for  $k_p$ , the length dimensions shown in Figure 43. These dimensions are heights of armor units in all cases. Jackson used rubble-mound structures, and relative core heights calculated from photos in his study have values of  $h_c/d_s \approx 1.14$ , except for a structure with one layer of modified cubes on a 1 on 3 slope which had a value of  $h_c/d_s \approx 1.4$ . Jackson's sketches of all structure cross sections indicate the core and lower underlayer to be below SWL. Since his photos show other cases, it is unclear what the values would be for the remaining situations.

Jackson's data, after conversion to deepwater variables, were compared to the smooth-slope curves. Results are summarized in Table 11. Each  $r$  value in the table is an average of  $r$  values determined for two or three wave steepnesses and for the slope and value of  $d_s/H'_0$  noted.

Table 11. Summary of  $r$  values (after Jackson, 1968a).

Armor unit and placement method	Armor layer thickness (No. of units)	Armor unit size ( $H'_0/k_p$ for $d_s/H'_0 = 5.0$ )	$r$ values for $d_s/H'_0 = 5.0^1$					
			1 on 1.5	1 on 1.75	1 on 2.0	1 on 2.25	1 on 3.0	Avg
Concrete tetrapod								
Random	2	2.30	0.45	---- <sup>2</sup>	0.40	---- <sup>2</sup>	0.39	0.41
Uniform	2	2.30	0.51	----	0.51	----	----	0.51
Leadite tetrapod								
Uniform	2	2.25	---- <sup>2</sup>	0.50	---- <sup>2</sup>	0.49	----	0.50
Concrete quadripod								
Random	2	2.90	0.51	----	0.47	----	0.49	0.49
Uniform	2	2.90	0.49	----	0.46	----	0.51	0.49
Leadite tribar								
Random	2	2.86	0.44	----	0.45	----	0.40 <sup>3</sup>	0.43
Uniform	1	2.86	0.50	----	0.50 <sup>3</sup>	----	----	0.50
Modified leadite cube								
Random	2	2.99	0.44	----	0.45	----	0.48	0.46
Uniform	1	2.99	0.62	----	0.73 <sup>3</sup>	----	0.55	0.65
Leadite hexapod								
Random	2	1.72	0.41	----	0.44	----	0.48	0.44
Uniform	1	1.72	0.52	----	0.51	----	----	0.52
Solid concrete tetrahedron								
Uniform	2	2.31	----	0.58	----	0.57	0.54	0.56
Perforated concrete tetrahedron								
Uniform	2	2.24	0.50	----	0.55	----	----	0.52
Solid leadite tetrahedron								
Uniform	2	2.29	0.54	----	0.54	----	----	0.54
Perforated leadite tetrahedron								
Uniform	2	2.22	0.50	----	0.51	----	----	0.51

<sup>1</sup> $d_s = 0.61$  meter (2 feet).

<sup>2</sup>No data available.

<sup>3</sup> $d_s/H'_0 = 3.0$ .

<sup>4</sup> $d_s/H'_0 = 4.0$ .

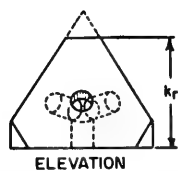

(a) Perforated tetrahedron

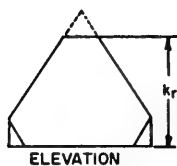

(b) Solid tetrahedron

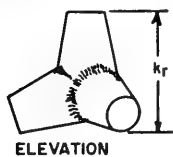

(c) Tetrapod

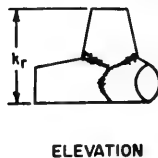

(d) Quadripod

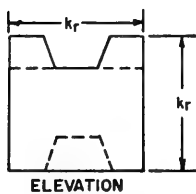

(e) Modified cube

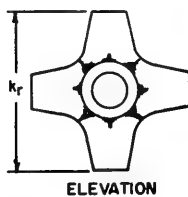

(f) Hexapod

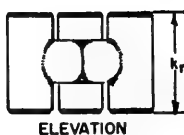

(g) Tribar

Figure 43. Concrete armor units tested by Jackson (1968a).

Dai and Kamel (1969) tested a permeable structure using quadripods in conjunction with scale-effect testing. Tests were limited to a 1 on 1.5 slope. Data from other investigators indicate that consistent runup values are difficult to obtain on a 1 on 1.5 slope, particularly on rubble slopes. Dai and Kamel's tests also seem to have considerable variance. Their structure configuration used for testing the quadripods was basically the same as used by Jackson (1968a), and some of the values were identical. The relative core height was approximately  $h_c/d_g \approx 1.1$ .

After reanalysis of Dai and Kamel's data, comparisons with the smooth-slope curves were made. Averages for each  $d_g/H_0^1$  value and scale combination were determined. These values indicate no significant differences between the quadripods with "smooth" and "rough" surfaces (terms used by Dai and Kamel); also, no significant difference is seen between scales. Individual values of  $r$  range from  $r \approx 0.38$  to  $r = 0.70$ , but the extremes appear to reflect questionable runup values as compared with other data. The overall average for the  $r$  values is  $r \approx 0.57$ . Table 12 presents values of  $r$  for quadripods on 1 on 1.5 slope and for specific  $d_g/H_0^1$  values, but each  $r$  value is an average of values obtained for one to five wave steepnesses each.

Table 12. Values of  $r$  for quadripods on 1 on 1.5 slope (after Dai and Kamel, 1969).

$\frac{d_g}{H_0^1}$	$\frac{H_0^1}{k_p}$	$r$ (avg)		
		$d_g = 0.305$ m (1 ft)	$d_g = 0.61$ m (2 ft)	$d_g = 4.57$ m (15 ft)
		Smooth quadripod	Quadripod	Rough quadripod
4.0	4.5	----- <sup>1</sup>	0.57, rough (2 points) 0.55, smooth (3 points)	0.63 (2 points)
5.0	3.6	0.49 (1 point)	0.55, rough (3 points) 0.57, smooth (3 points)	0.57 (4 points)
8.0	2.3	0.59 (5 points)	0.61, rough (3 points) 0.60, smooth (5 points)	0.46 (2 points)

<sup>1</sup>No data.

Vanoni and Raichlen (1966) tested a relatively high core structure with relative core heights of  $h_c/d_g \approx 1.32$  and  $h_c/d_g \approx 1.79$ . In the latter case, runup did not exceed the core height (discussed in Sec. V,2,b). The structure slope was first built with one layer of tribars from below SWL to a point slightly below the core elevation, and then the upper part of the structure was built of quarrystone. The tribar section extended above SWL to a height approximately equal to the maximum wave amplitude at the structure toe. The tribars and quarrystone were underlain by two filter layers. Nonbreaking waves were used; runup was caused by surging waves.

The slope tested by Vanoni and Raichlen was a 1 on 3 uniform slope; test results for certain conditions are given as values of  $r$  in Table 13. Runup for  $d_g/H_0^1 \geq 5.0$  was limited to the tribar zone, and extended up into the quarrystone section for  $2 \leq d_g/H_0^1 < 5$ . No noticeable difference in  $r$  values is seen which would be attributable to the water passing over different armor unit types; e.g., comparison of  $r$  values for  $d_g/H_0^1 = 3.0$  and  $d_g/H_0^1 = 5.0$ .

Table 13. Values of  $r$  for tribars and quarrystone on a 1 on 3 slope (after Vanoni and Raichlen, 1966).

$\frac{d_g}{H'_0}$	$\frac{H'_0}{k_T}$ (tribar)	$\frac{H'_0}{k_T}$ (quarrystone) <sup>1</sup>	$\frac{H'_0}{gT^2}$	$r$
$d_g = 0.257 \text{ m (0.844 ft)}$				
3.0	2.11	2.53	0.00155	0.48
			0.0020	0.47
			0.00285	0.43
5.0	1.27		0.00092	0.48
			0.0012	0.46
			0.0017	0.40
8.0	0.79		0.00056	0.42
			0.00076	0.41
			0.00104	0.27
$d_g = 0.29 \text{ m (0.95 ft)}$				
3.0	2.38	2.84	0.0015	0.46
5.0	1.43		0.0012	0.47
8.0	0.89		0.00077	0.38
Overall avg				0.43

<sup>1</sup>Quarrystone was at a higher elevation than the tribars; runup did not reach the quarrystone section for  $d_g/H'_0 \geq 5.0$ .

Vanoni and Raichlen tested various model-to-prototype scales. Scales were 1:40 and 1:45 in the cases discussed above; however, the scales are not appreciably different and observed runup values were comparable between scales. The principal reason for using different scales was the ability to model prototype armor units of varying weight (and stability) with the same model armor unit.

Results from Vanoni and Raichlen (1966), Jackson (1968a), and Dai and Kamel (1969) for selected armor units are summarized in Table 14. The Vanoni and Raichlen tests were for rather small scales; Jackson, and also Dai and Kamel, had intermediate scales, and Dai and Kamel included tests at a large scale. Quarrystone values are included in the table with Jackson's test results for size comparison with the quarrystone used by Vanoni and Raichlen.

Dai and Kamel's tests for quadripods, including tests at the same scale, give  $r$  values slightly higher than Jackson's. The difference may be partly attributable to different experimental setups and partly to different relative sizes of the quadripods.

The tribar tests of Vanoni and Raichlen give  $r$  values comparable to those of Jackson. Lower  $r$  values would be expected for the former because of lower  $H'_0/k_r$  values (or larger armor unit size relative to the wave) but the effect (if present) is apparently offset by the higher core of Vanoni and Raichlen's structure--which would increase runup somewhat by reducing wave transmission--and because Vanoni and Raichlen tested one layer of tribars compared with the two layers tested by Jackson.

(2) Impermeable Structures. Testing of concrete armor units on impermeable slopes has been rather limited; most testing has involved permeable rubble-mound structures designed for high-energy environments. Only two sets of tests for concrete armor units on impermeable slopes are discussed here, one for runup on tribars and the other for runup on Gobi blocks.

Vanoni and Raichlen (1966) tested a structure with a 1 on 3 slope fronted by a horizontal bottom and armored with a combination of tribars and quarrystones. Tribars extended from below SWL to a distance above SWL, but the distance varied depending on the water depth. Quarrystones extended the rest of the way to the structure crest.

One set of the experiments was for a relatively low water level, for which all runup was both below the quarrystone level and below the crest of the core. These conditions essentially constitute an impermeable structure. The correction factors ( $r$ ) given in Table 15 can be compared with values in Table 13. Values of  $H'_0/k_r$  in Table 15 are markedly lower than those in Table 13, and the greater roughness is certainly a major reason for the lower correction factors in Table 15.

Table 14. Summary of r values for structures fronted by a horizontal bottom (with approximately two layers of armor units randomly placed on the structure face).

Source	Slope (cot $\theta$ )	$d_g$ , m (ft)	Armor unit	Relative core height ( $h_c/d_g$ )	Range of $d_g/H_0$ analyzed	r (avg)
Jackson (1968a)	1.33 to 2.25	0.61 (2.0)	Rough quarrystone $H_0/k_T = 2.45$ at $d_g/H_0 = 5.0$	$\approx 1.14$	5.0	0.48
		0.61 (2.0)	Smooth quarrystone $H_0/k_T = 2.70$ at $d_g/H_0 = 5.0$	$\approx 1.14$	5.0	0.52
	1.5 to 3.0	0.61 (2.0)	Concrete quadripod $H_0/k_T = 2.90$ at $d_g/H_0 = 5.0$	$\approx 1.14$	5.0	$\approx 0.49$
		0.61 (2.0)	Leadite tribar $H_0/k_T = 2.86$ at $d_g/H_0 = 5.0$ (Other units in Table 11)	$\approx 1.14$	4.0, 5.0	$\approx 0.43$
Dai and Kamei (1969)	1.5	0.3 (1.0)	Rough and smooth quadripod $H_0/k_T = 3.6$ at $d_g/H_0 = 5.0$	$\approx 1.10$	5.0, 8.0	0.57
		0.61 (2.0)	Rough and smooth quadripod $H_0/k_T = 3.6$ at $d_g/H_0 = 5.0$	$\approx 1.10$	4.0 to 8.0	0.58
		4.6 (15.0)	Rough and smooth quadripod $H_0/k_T = 3.6$ at $d_g/H_0 = 5.0$	$\approx 1.10$	4.0 to 8.0	0.56
Vanoni and Raichlen (1966) <sup>1</sup>	3.0	0.26 (0.84)	Quarrystone $H_0/k_T = 1.52$ at $d_g/H_0 = 5.0$	$\approx 1.32$	3.0 to 8.0	$\approx 0.44$
			Tribar $H_0/k_T = 1.27$ at $d_g/H_0 = 5.0$			
		0.29 (0.95)	Quarrystone $H_0/k_T = 1.71$ at $d_g/H_0 = 5.0$	$\approx 1.32$	3.0 to 8.0	$\approx 0.44$
			Tribar $H_0/k_T = 1.43$ at $d_g/H_0 = 5.0$			

<sup>1</sup>One layer of tribars.

Table 15. Values of  $r$  for one layer of tribars on 1 on 3 slope with tribars underlain by two filter layers (after Vanoni and Raichlen, 1966).

$d_s/H_0'$	$H_0'/k_r$	$H_0'/gT^2$	$r$
$d_s = 0.19 \text{ m (0.622 ft)}$			
3.0	1.56	0.00113	0.40
		0.00148	0.38
		0.00201	0.39
5.0	0.94	0.00068	0.39
		0.00089	0.38

Another set of runup tests was conducted by McCartney and Ahrens (1975), using Gobi blocks (Fig. 44) which are used for revetment in low-energy wave climates. The full-size block weighs approximately 6.35 kilograms (14 pounds) and is placed in a matlike arrangement on the slope. Tests were conducted with a 4.57-meter water depth, and were limited to a relative depth of  $d_s/H_0' = 8.0$  and slope of 1 on 3.5. Rough-slope to smooth-slope ratios were  $r \approx 0.93$ , a high value for a roughened slope, but it indicates the relatively smooth surface presented by Gobi blocks.

Conditions Tested:  $d_s = 4.57 \text{ m (15 ft)}$   
 $d_s/H_0' \approx 8.0$   
 $H_0'/k_r \approx 5.7$   
 1 on 3.5 slope  
 Horizontal bottom

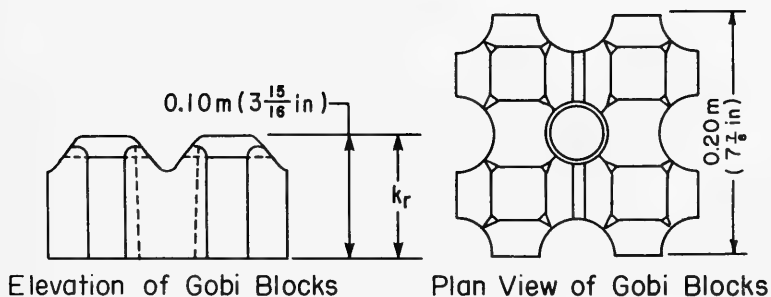

Figure 44. Gobi blocks (McCartney and Ahrens, 1975).

c. Example Problems.

\*\*\*\*\* EXAMPLE PROBLEM 8 \*\*\*\*\*

GIVEN: .Quarrrystone rubble-mound breakwater;  $\cot \theta = 2$ ;  $\cot \beta = 80$ ;  
 $d_s = 6.0$  meters (19.7 feet);  $H'_O = 2.0$  meters (6.6 feet);  
 $T = 4.0$  seconds;  $k_p = 0.6$  meter (2.0 feet);  $h_c = 4.5$  meters  
 (14.8 feet).

FIND: Determine runup.

SOLUTION:

$$\frac{d_s}{H'_O} = 3.0; \quad \frac{H'_O}{k_p} = 3.33; \quad \frac{h_c}{d_s} = 0.75;$$

$$\frac{H'_O}{gT^2} = \frac{2}{(9.81)(4)^2} = 0.0127 .$$

Assume  $\beta \approx 0$ , since the bottom slope is gentle and  $d_s/H'_O$  is not small. The structure is a rubble-mound breakwater with a low core (see Figs. 25, 26, and 27).  $H'_O/k_p$  in this problem is less than that given for  $d_s/H'_O = 3.0$  in Figure 25, so the results of Figure 25 should be conservative.

$$\frac{R}{H'_O} \approx 0.66 \text{ (from Fig. 25).}$$

$$R = (0.66)(H'_O)$$

$$= (0.66)(2)$$

$$R = 1.32 \text{ meters (4.3 feet).}$$

Evaluation of possible scale effects is discussed in Section VI.

\*\*\*\*\*

\*\*\*\*\* EXAMPLE PROBLEM 9 \*\*\*\*\*

GIVEN: Quarrrystone riprap structure;  $\cot \theta = 3$ ;  $\beta = 0$ ;  $d_s = 6.0$  meters;  
 $H'_O = 1.2$  meters (3.9 feet);  $T = 4.0$  seconds;  $k_p \approx 0.4$  meter (1.3 feet).

FIND: Determine runup.

SOLUTION:

$$\frac{d_s}{H'_O} = 5.0; \quad \frac{H'_O}{k_p} = 3.0$$

$$\frac{H'_O}{gT^2} = \frac{1.2}{(9.81)(4)^2} = 0.0076$$



Then from Figure 40, for a riprap structure,

$$\frac{R}{H'_O} \approx 0.92$$

$$R = (0.92)(H'_O) \\ = (0.92)(1.2)$$

$$R = 1.1 \text{ meters (3.6 feet)}$$

Figure 40 is derived from large-scale experiments, and no correction for scale effects is necessary (discussed further in Sec. VI).

\*\*\*\*\*

\*\*\*\*\* EXAMPLE PROBLEM 10 \*\*\*\*\*

GIVEN: Rubble-mound structure using two randomly placed layers of tri-bars for protection;  $\cot \theta = 1.5$ ;  $\beta = 0$ ;  $d_s = 10.0$  meters;  $H'_O = 3.4$  meters (11.2 feet);  $T = 6.2$  seconds;  $h_c \approx 10.0$  meters;  $k_T \approx 0.7$  meter (2.3 feet), where  $k_T$  is the length (height) of a tribar leg.

FIND: Determine runup.

SOLUTION:

$$\frac{d_s}{H'_O} = 2.94 \approx 3.0; \quad \frac{H'_O}{k_T} = 4.86; \quad \frac{h_c}{d_s} \approx 1.0$$

$$\frac{H'_O}{gT^2} = \frac{3.4}{(9.81)(6.2)^2} = 0.009 \text{ .}$$

This structure is similar in design (high core) to the rubble-mound breakwater tested by Jackson (1968a) for which  $r$  values are given in Table 11. However,  $r$  values are not listed for tribars for the condition of  $H'_O/k_T = 4.9$ . An estimate of  $r$  is necessary. Relative roughness in Table 11 is specified for a particular relative depth,  $d_s/H'_O = 5.0$ . For  $d_s/H'_O = 5.0$ , the relative roughness in this problem would be

$$\frac{H'_O}{k_T} = \left( \frac{1}{d_s/H'_O} \right) \left( \frac{d_s}{k_T} \right) \\ = \left( \frac{1}{5} \right) \left( \frac{10}{0.7} \right)$$

$$\frac{H'_O}{k_T} = 2.86, \text{ for } \frac{d_s}{H'_O} = 5.0 \text{ .}$$

Therefore, the tribar relative roughness of this problem is the same as tested by Jackson, for which results are given in Table 11. For  $\cot \theta = 1.5$ ,  $d_s/H'_0 = 5.0$ , and  $H'_0/k_r = 2.86$ ,  $r_{tribar} \approx 0.44$ . However, this problem requires an answer for  $d_s/H'_0 = 3.0$ ; lacking further information,  $r \approx 0.44$  will be used in this problem. The results of various investigations referenced in this study indicate that  $r$  is not necessarily constant for changing  $H'_0/k_r$  values or changing  $d_s/H'_0$  values; thus, assuming here that  $r$  is a constant 0.44 is simply a best estimate. The chosen  $r$  value is applied to the applicable smooth-slope relative runup value. For the wave conditions and structure slope corresponding to this problem, smooth-slope relative runup is, from Figure 14,

$$\frac{R}{H'_0}_{smooth} = 1.82 .$$

The estimated relative runup on this tribar-covered rubble mound is then

$$\begin{aligned} \left(\frac{R}{H'_0}\right)_{rough} &= r \left(\frac{R}{H'_0}\right)_{smooth} \\ &= (0.44)(1.82) \end{aligned}$$

$$\left(\frac{R}{H'_0}\right)_{rough} = 0.80 .$$

The runup on this rubble mound is

$$\begin{aligned} R &= \left(\frac{R}{H'_0}\right)_{rough} (H'_0) \\ &= (0.80)(3.4) \\ R &\approx 2.7 \text{ meters (8.9 feet)} . \end{aligned}$$

Evaluation of possible scale effects is discussed in Section VI.

\*\*\*\*\*

### 3. Stepped Slopes.

Stepped-slope configurations have been tested for use in low-energy wave climates. Field construction techniques vary, but include case-in-place steps, such as in Harrison County, Mississippi, and soil-cement stepped surfaces (Nussbaum and Colley, 1971). Laboratory tests have been performed on precast, interlocking stepped blocks (Jachowski, 1964), on impermeable steps (Saville, 1955) and on soil-cement stepped slopes (Nussbaum and Colley, 1971). Saville's tests were conducted with the

structure fronted by a 1 on 10 bottom slope; the structures in other tests extended to the flat bottom of the wave tanks.

Saville's results for the 1 on 1.5 stepped slope are plotted in Figures 45 and 46. Figure 45 has the data points for a depth greater than zero at the structure toe. Figure 46 has data for a zero toe depth at the structure; however, slightly different dimensionless variables are used. Both on the stepped slope and on smooth slopes the relative depth, defined at some point seaward of the structure, is important even with a zero toe depth. Curves of constant  $d_s/H'_0$  have been drawn in Figure 45. The ratios of stepped-slope runoff to smooth-slope runoff are given in Table 16 for water depths greater than zero at the structure toe, and in Table 17 for the zero water depth. The  $r$  value for  $d_s/H'_0 = 0.38$  in Table 16 is based on one point only and a higher average value would be expected.

Table 16. Ratios of stepped-slope runoff to smooth-slope runoff; 1 on 1.5 structure slope; 1 on 10 bottom slope;  $d_s > 0$  (after Saville, 1955).

$d_s/H'_0$	$H'_0/k_p$ <sup>1</sup>	$r$ (avg)
0.38	12.0	0.56 <sup>2</sup>
0.75	6.0 and 12.0	0.74
1.5	3.0 and 6.0	0.80
3.0	3.0	0.76

<sup>1</sup> $k_p$  is the step height.

<sup>2</sup>Based on only one point.

Table 17. Ratios of stepped-slope runoff to smooth-slope runoff; 1 on 1.5 structure slope; 1 on 10 bottom slope;  $d_s = 0$  (after Saville, 1955).

$d/H'_0$ <sup>1</sup>	$H'_0/k_p$ <sup>2</sup>	$r$ (avg)
4.1	6.0	0.70
8.3	3.0	0.74

<sup>1</sup>Use  $d/H'_0$ , not  $d_s/H'_0$ .

<sup>2</sup> $k_p$  is step height.

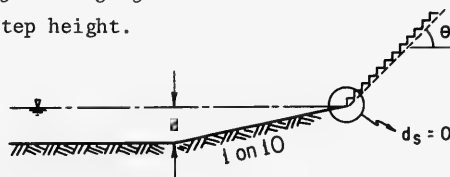

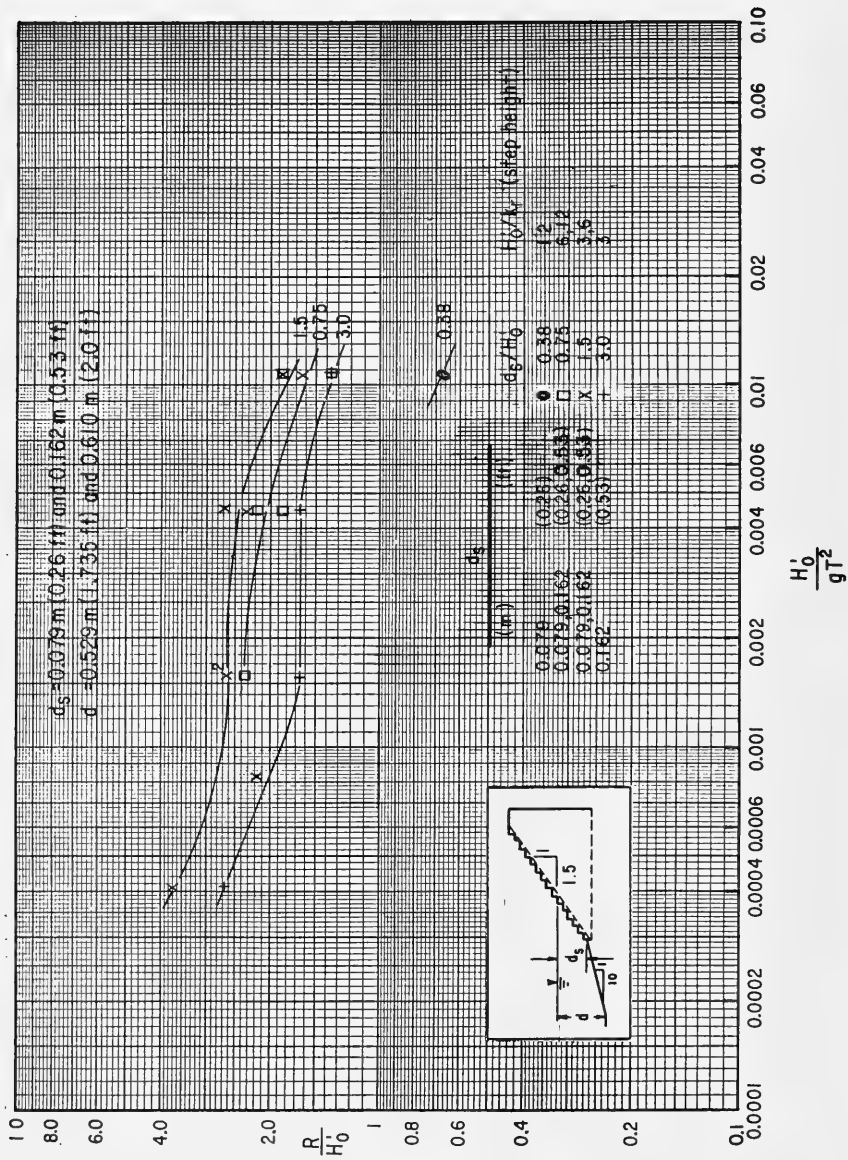

Figure 45. Stepped-slope runup;  $d_S \neq 0$ ; 1 on 1.5 structure slope; 1 on 10 bottom slope (Saville, 1955).

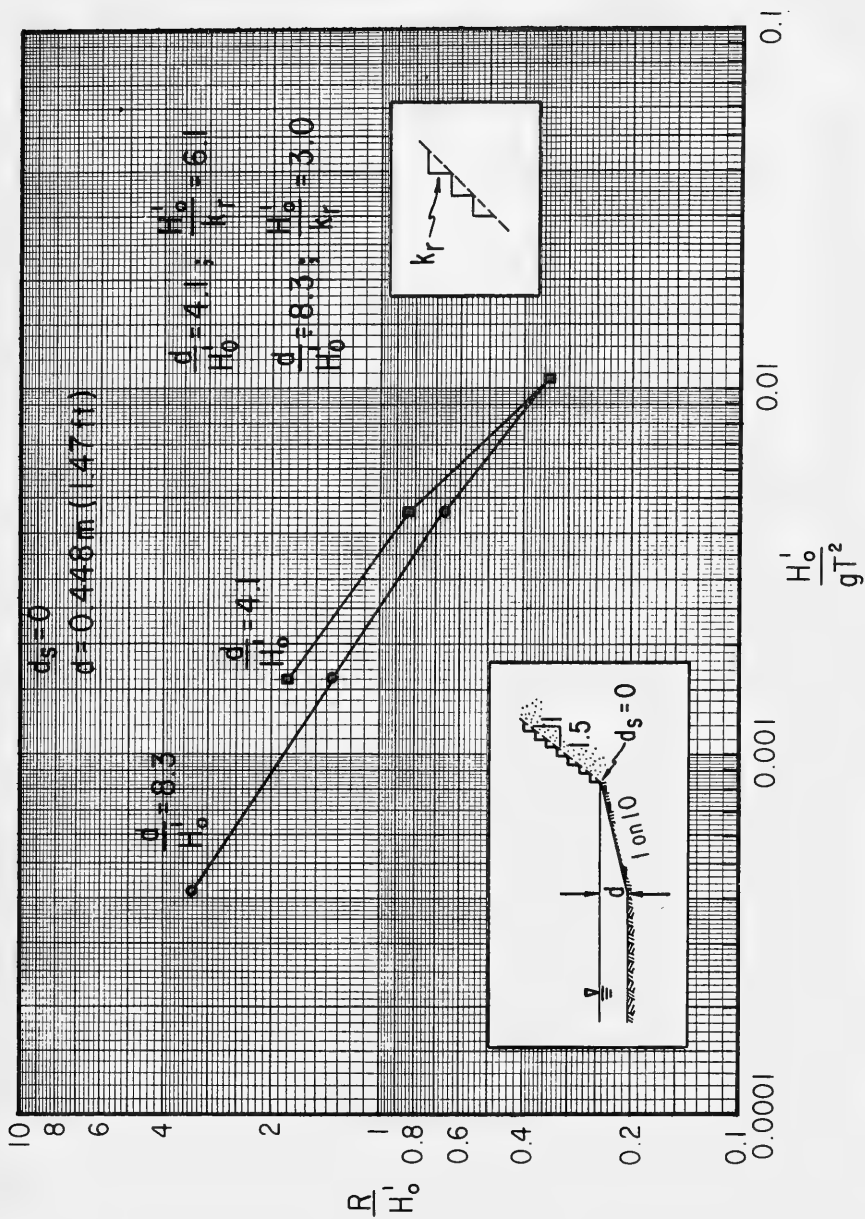

Figure 46. Stepped-slope runup;  $d_s = 0$ ; 1 on 1.5 structure slope; 1 on 10 bottom slope (Saville, 1955).

Values of  $r$  used in Table 16 are averages for several wave steepnesses. In tests of structures sited on flat bottoms, the  $r$  value does not seem significantly influenced by varying wave steepness values. Saville's (1955) data (Table 16) show high  $r$  values for steep waves ( $H'_0/gT^2 \approx 0.006$  and greater); individual  $r$  values were as high as 0.93. These high  $r$  values may be a result of the measurement of maximum values of runup or an expression of the lesser importance of roughness when waves break seaward of the structure toe.

Jachowski (1964) and Nussbaum and Colley (1971) tested stepped slopes sited on flat bottoms. Both tested 1 on 2 and 1 on 3 structure slopes using vertical-faced steps with sharp edges. Jachowski also tested interlocking blocks with inclined risers (upper edge seaward of lower edge). Nussbaum and Colley also tested steps with rounded edges which would represent eroded or worn conditions for the soil-cement steps. Selected data of Jachowski and of Nussbaum (personal communication, 1975) were reviewed and compared to smooth-slope runup values.

Table 18 indicates  $r$  values of approximately 0.70 for vertical-faced steps, although the 1 on 2 slope appears to have slightly higher values. The rounded-step slopes have significantly higher  $r$  values, as would be expected, and have values of  $r \approx 0.85$ .

#### 4. Estimation of Rough-Slope Runup.

Most runup tests have been conducted for restricted conditions. Some structure configurations or wave conditions have not been tested or have been tested only rarely. Few runup data are available, for example, for a rubble structure fronted by a sloping beach and for which waves are breaking at the structure toe. Actual runup tests for design conditions are the most desirable means of estimating runup under prototype conditions. In lieu of test results, some method of estimation is necessary.

This study has presented rough-slope runup data in terms of the factor  $r$ , which is the ratio of rough-slope runup to smooth-slope runup for the same conditions. Such a factor was suggested by Hunt (1959), the U.S. Army, Corps of Engineers, Coastal Engineering Research Center (1966), and the Technical Advisory Committee on Protection Against Inundation (1974). This factor, as envisioned, would vary simply as a function of the structure's armor layer construction. It would be applied to known smooth-slope runup values to estimate rough-slope runup for conditions not tested. Actually, the factor  $r$  appears to be as highly dependent on the several wave and structure conditions as relative runup,  $R/H'_0$ . For example, the range of individual  $r$  values for quarystone riprap slopes was, for  $4 \leq d_s/H'_0 \leq 10$  and  $1.5 \leq H'_0/k_p \leq 5$  and the slopes noted: 1 on 1.5,  $0.53 < r < 0.68$ ; 1 on 2.5,  $0.51 < r < 0.69$ ; 1 on 3.5,  $0.43 < r < 0.67$ ; 1 on 5,  $0.44 < r < 0.79$ . Thus, any one value of  $r$  does not seem applicable for all wave conditions for a given armor unit; however, values of  $r$  are still useful as estimators of runup on rough slopes when smooth-slope data are available and rough-slope data are lacking.

Table 18. Ratios of stepped-slope runoff to smooth-slope runoff (horizontal bottom).

Source	Slope	$d_s$ , m (ft)	Step type	$d_s/H_0$	$H_0/k_p$ <sup>1</sup>	$\bar{r}$ (avg)
Jachowski (1964)	1 on 2	0.381 (1.25)	Vertical	4.0	5.0	0.74
				8.0	2.5	0.75
				15.0	1.3	0.76
Jachowski (1964)	1 on 3	0.381 (1.25)	Vertical	4.0	5.0	0.64
				8.0	2.5	0.64
				15.0	1.3	0.68
Nussbaum and Colley (1971)	1 on 3	0.46 (1.5)	Vertical (sharp edge)	2.5	7.2	0.73
				3.0	6.0	0.67
				5.0	3.6	0.66
				8.0	2.25	0.67
Nussbaum and Colley (1971)	1 on 3	0.53 (1.75)	Vertical (rounded edge)	3.0	7.0	0.90
				5.0	4.2	0.82
				8.0	2.63	0.82

<sup>1</sup> $k_p$  is height of step.

This study has discussed  $r$  values, considering some of the variables, principally structure slope and cross section, relative armor size, and relative depth. Variations in  $r$  with wave steepness were present but no consistent trends were observed, and  $r$  values were usually averaged for the few wave steepness values for each relative depth and relative armor size at which runup was obtained.

In application, a value (or range of values) of  $r$  is determined for the desired structure slope, cross section (high or low core, if applicable), type of armor unit, and relative armor size. This  $r$  value is then multiplied by the smooth-slope runup value to give an estimated rough-slope runup. The smooth-slope value is determined from the smooth-slope design runup curves given in Section V,1 which are similar to but expanded from those in the SPM. The smooth-slope runup should be determined without any scale-effect correction (discussed in Sec. VI). After determination of the rough-slope runup, it is suggested that the scale-effect correction be applied which is applicable to the data from which the  $r$  value is derived, although variability in  $r$  values is greater than the applicable rough-slope scale-effect corrections.

\*\*\*\*\* EXAMPLE PROBLEM 11 \*\*\*\*\*

GIVEN: Quarystone rubble-mound structure;  $\cot \theta = 1.5$ ;  $\cot \beta = 40$ ;  
 $H_D = 2.2$  meters (7.2 feet);  $T = 8.9$  seconds;  $h_c = 3.4$  meters;  
 $k_p \approx 0.815$  meter (2.7 feet);  $d_s = 3.14$  meters (10.3 feet).

FIND: Determine runup.

SOLUTION:

$$\frac{d_s}{H_D'} = 1.43; \quad \frac{H_D'}{k_p} = 2.7; \quad \frac{h_c}{d_s} \approx 1.1 ;$$

$$\frac{H_D'}{gT^2} = \frac{2.2}{(9.81)(8.9)^2} = 0.00283 .$$

This structure is similar in design to the rubble-mound breakwater tested by Jackson (1968a). However,  $d_s/H_D'$  is lower than tested, and waves breaking at the structure toe may be expected. Accordingly, an  $r$  value needs to be determined along with smooth-slope runup for a similar geometry. From Table 8, for  $H_D'/k_p = 2.7$  and  $\cot \theta = 1.5$ ,

$$r \approx 0.52 .$$

Smooth-slope runup is determined from the curves in Section V,1. This problem has  $\cot \beta = 40$ , but the only beach slope available in Section V,1 is  $\cot \beta = 10$ . Nevertheless, from Figure 22, for  $d_s/H_D' \approx 1.5$ ,  $\cot \theta = 1.5$ , and  $H_D'/gT^2 = 0.0028$ ,

$$\frac{R}{H_D' \text{ smooth}} \approx 3.6 .$$



The estimated rough-slope relative runup is then

$$\begin{aligned}\left(\frac{R}{H_o'}\right)_{rough} &= r \left(\frac{R}{H_o'}\right)_{smooth} \\ &= (0.52) (3.6) \\ \left(\frac{R}{H_o'}\right)_{rough} &= 1.87.\end{aligned}$$

The estimated runup is

$$\begin{aligned}R_{rough} &= \left(\frac{R}{H_o'}\right)_{rough} (H_o') \\ &= (1.87) (2.2) \\ R_{rough} &= 4.1 \text{ meters (13.5 feet).}\end{aligned}$$

Evaluation of possible scale effects is discussed in Section VI,4.

\*\*\*\*\*

## VI. SCALE EFFECTS

### 1. General.

The study of scale effects in runup has been limited. The SPM contains runup corrections for smooth slopes based on work by Saville (1958). Dai and Kamel (1969) studied scale effects on rubble-mound structures sited on flat beaches, both for stability of armor units and for runup. These studies incorporated tests from near-prototype conditions where water depths at the structure toe were on the order of 3.0 to 4.6 meters (10.0 to 15.0 feet). Other runup studies, while designed for a particular model-to-prototype scale, have implicit scale-effect data, in that water depths at the structure toe were varied but wave conditions were identical as measured by dimensionless variables. However, the model scales usually vary only by a factor of two or so, and the effect is not differentiable from variance in runup values for specified conditions. Examples are given in Saville (1955, 1956). Hudson, Jackson, and Cuckler (1957) used model scales differing by a factor of approximately two in different wave tanks for a 1 on 6 smooth slope. Dai and Jackson (1966) tested a rubble-mound structure with 1 on 2 slope on a beach of 1 on 30 slope at the structure and 1 on 370 farther seaward; model-to-prototype scales of 1:50 and 1:100 were used. Their observations had a great deal of scatter, and neither model scale showed consistently higher nor lower relative runup values. Hudson and Jackson (1962) studied riprap on slopes of 1 on 2 and 1 on 3 for two prototype depths, two model scales, and differing prototype rock sizes. Ahrens (1975a) tested riprap slopes at near-prototype scale.

## 2. Reynolds Number.

Model-to-prototype ratios have often been designated for model tests because many tests are for specific site conditions. However, evaluation of scale effects among a collection of model tests is difficult when using the model-to-prototype ratios because the same model dimensions may be modeling greatly different prototype conditions. An example might be comparison of a 1:20-scale model with a 1:50-scale model, both of which might have the same model dimensions. Direct comparisons between various model scales are possible by using dimensionless variables, including a Reynolds number, assuming viscosity is the primary cause of scale effects.

Reynolds numbers ( $R_e$ ) used in various studies involving oscillatory flow are not defined by convention, but rather in ways convenient to the particular study; thus, no one definition is used consistently. Dai and Kamel (1969) conducted model tests at three different scales. A Reynolds number was defined using, for velocity, the water particle velocity parallel to the side slope at a distance below SWL related to the armor unit size. The length unit is the characteristic armor unit diameter. The velocity is determined from empirical graphs, and is a function of period, depth, and armor unit diameter. However, a separate graph is apparently required for each wavelength and only one is given. This  $R_e$  is difficult to use as defined.

Hudson and Davidson (1975) present data from Dai and Kamel (1969) using a different Reynolds number for rubble-mound stability tests defined as

$$R_e = \frac{(gH_{D=0})^{1/2} (k_r)}{\nu}, \quad (10)$$

where

- $g$  = gravitational value
- $H_{D=0}$  = zero-damage wave height
- $k_r$  = characteristic diameter
- $\nu$  = kinematic viscosity of water

This latter definition is more "workable," but depends on the empirical value of  $H_{D=0}$ .

The implicit understanding when plotting data against  $R_e$  must be that the other required dimensionless terms have the same value in the different scale models. Hudson and Davidson plot the stability number versus  $R_e$ , and the assumption in this case, then, would be that the wave conditions are sufficiently specified by using the zero-damage wave height and armor unit dimension. For the plot given by Hudson and

Davidson, a critical  $R_e$  is found at  $R_e \approx 3 \times 10^3$ . Scale effects cease to be important for  $R_e$  values larger than this critical value.

In evaluating scale effects in runup, a Reynolds number may again be defined and used for plotting  $R/H'_0$  versus  $R_e$ , but only if the remaining dimensionless variables are equal between models. This would allow comparison for one set of conditions (i.e., waves with  $H_{D=0}$ ), as was done by Hudson and Davidson, or for a whole range of conditions, leading possibly to differing scale effects for different wave conditions; e.g., different wave steepnesses, relative depths, etc.

The Reynolds number used in this study is a "depth" Reynolds number (defined in Sec. II):

$$(R_e)_d = \frac{(gd)^{1/2} d}{\nu} \quad (11)$$

The depth,  $d$ , is arbitrary but must be considered in the dimensional analysis. Here,  $d_s$ , the depth at the toe of the structure slope, is the depth variable. The Reynolds number then is

$$R_e = (R_e)_d = \frac{(gd_s)^{1/2} d_s}{\nu} \quad (12)$$

This definition is particularly useful because the terms are easily defined. The term  $(gd_s)^{1/2}$  may be recognized as the shallow-water wave celerity; however, it is not synonymous with the actual wave speed tested because nearly all runup tests were conducted in transitional or deep water.

As examples, the three scales of Dai and Kamel (1969) have  $R_e$  values for the specific depths as given in Table 19. The value of  $\nu$  is that for freshwater at 16° Celsius:  $\nu \approx 1.21 \times 10^{-5}$  feet squared per second =  $1.124 \times 10^{-6}$  meters squared per second. A family of curves might be drawn as shown schematically in Figure 47. If the scale effects are the same, over a range of  $R_e$  values for each set of specified wave conditions, then the curves should all have the same shape. However, runup data obtained at different scales but with comparable test conditions are insufficient to adequately define scale effects. Therefore, it has not been clearly established that scale effects follow the trends as suggested in Figure 47; i.e., scale effects are the same for varying wave conditions.

Table 19. Reynolds numbers for three different depths.

$d_s$ , m (ft)	4.57 (15)	0.61 (2)	0.30 (1)
$R_e$	$2.72 \times 10^7$	$1.33 \times 10^6$	$4.69 \times 10^5$

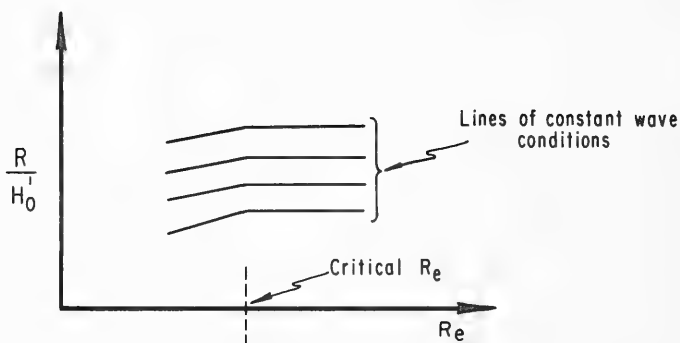

Figure 47. Hypothetical sketch of relative runup variations (scale effects) on a given structure for sets of specified wave conditions and varying Reynolds number.

### 3. Smooth-Slope Scale Effects.

Limited large-scale data for smooth slopes on a 1 on 10 bottom slope are available (Saville, 1958; 1960). From this data and other appropriate small-scale data, Figure 48 was prepared in the manner previously discussed. The figure gives results only for  $d_s/H_0' = 1.5$ , because the large-scale data were limited to a narrow range of  $d_s/H_0'$  values close to  $d_s/H_0' = 1.5$ . Small-scale data used are from Saville (1955, 1956, 1958, 1960), and Hudson, Jackson, and Cuckler (1957). The small-scale tests by Saville (1958) were one-tenth the scale of his large-scale tests, and the geometrical arrangement was the same in both cases. Saville's data are given in Table 20. The smooth slope was not modeled exactly between scales, because plywood was used for both the small- and large-scale tests and the small scale may have been proportionately rougher. An attempt to closely model the slope roughness is discussed later in this section.

In the small-scale tests, the variability of results for the 1 on 3 slope is pronounced (Fig. 48). The range of runup values derived from Hudson, Jackson, and Cuckler (1957) for  $Re = 9 \times 10^4$  encompasses those runup values of the largest scale ( $Re = 3.75 \times 10^6$ ). Also, for the 1 on 3 slope, the data of Saville (1955) vary considerably between the two Reynolds numbers,  $Re = 6.3 \times 10^4$  and  $1.8 \times 10^5$ . In contrast to the 1 on 3 slope, the 1 on 6 slope values show less variability.

Comparisons in Figure 48 were not extended to lower wave steepnesses because the large-scale test conditions were such that at low wave steepnesses, the waves were long relative to the bottom slope ( $\ell/L$  values of 0.21 and 0.30 were tested). However, even for the wave conditions given in the figure,  $\ell/L$  values varied between certain experiments. Thus, test conditions are similar but not necessarily the same.

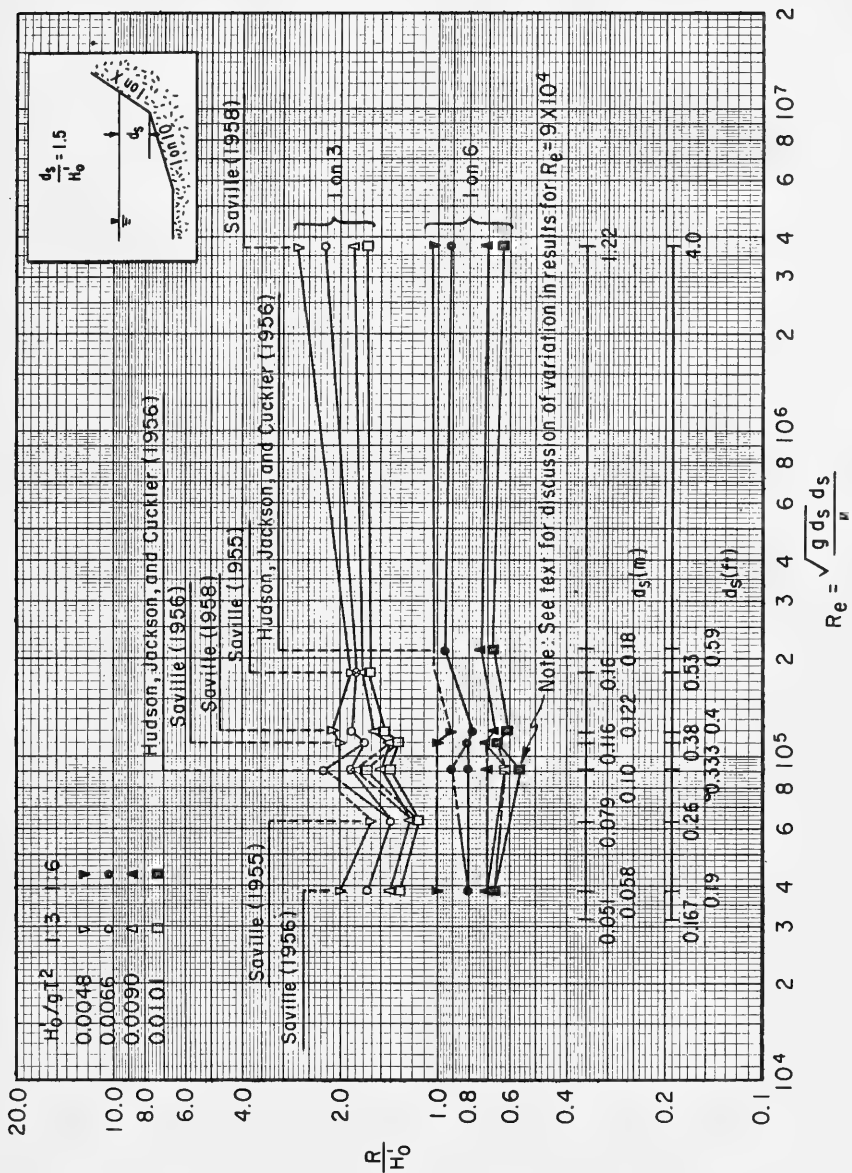

Figure 48. Scale effects on smooth-slope rumup as function of Reynolds number;  $d_s/H_0' = 1.5$ ; 1 on 3 and 1 on 6 structure slopes; 1 on 10 bottom slope.

Table 20. Comparisons of smooth-slope rumup between small and large scales for 1 on 3 and 1 on 6 structure slopes with 1 on 10 beach slope (after Saville, 1958, 1960).

$d_g/gT^2$	$H_b^3/gT^2$	Small scale <sup>1</sup> $d_g = 0.12 \text{ m (0.4 ft)}$ $R/H_b^3$	Large scale <sup>2</sup> $d_g = 1.2 \text{ m (4.0 ft)}$ $R/H_b^3$	$\frac{(R/H_b^3)_{large}}{(R/H_b^3)_{small}}$	Group avg
1 on 3 structure slope					
0.000485	0.00011	4.7	5.2	1.11	1.04
0.000485	0.00023	6.2	6.5	1.05	
0.00097	0.00026	3.75	3.88	1.035	
0.00201	0.00041	2.0	1.97	0.98	
0.00097	0.00071	4.37	4.47	1.02	
0.00097	0.00102	3.07	4.045	1.32	1.15
0.00201	0.00131	2.67	2.69	1.01	
0.00201	0.0027	2.33	2.67	1.15	
0.00647	0.00278	2.58	3.27	1.27	
0.0088	0.0048	1.98	2.55	1.29	
0.00647	0.0049	2.21	2.82	1.28	1.25
0.00647	0.0080	1.32	1.64	1.24	
0.0128	0.0083	1.78	1.88	1.06	
0.0088	0.0084	1.44	1.97	1.37	
0.0088	0.0101	1.10	1.30	1.18	
0.0128	0.0104	1.54	1.89	1.23	1.25
0.0128	0.0125	1.09	1.46	1.34	
0.0182	0.0135	1.21	1.52	1.26	
Overall avg					
1 on 6 structure slope					
0.000485	0.00011	5.02	5.57	1.11	1.12
0.00097	0.00026	3.75	4.33	1.16	
0.0020	0.000395	2.51	2.78	1.11	
0.0020	0.00131	1.72	1.87	1.09	1.13
0.00647	0.00278	1.28	1.49	1.16	
0.0088	0.0048	1.0	1.16	1.16	1.17
0.00647	0.0049	0.89	1.08	1.21	
0.00647	0.0080	0.63	0.75	1.19	
0.0128	0.0083	0.68	0.73	1.07	
0.0088	0.0084	0.64	0.77	1.20	
0.0088	0.0101	0.53	0.63	1.19	1.14
0.0128	0.0104	0.58	0.63	1.09	
0.0128	0.0125	0.47	0.56	1.19	
0.0182	0.0135	0.49	0.54	1.10	
Overall avg					1.14

$$^1R_g = 1.19 \times 10^5.$$

$$^2R_g = 3.75 \times 10^6.$$

In three of the small-scale tests (Fig. 48), toe depths were varied by a factor of two. Therefore, scale effects within the runup results of each study are potentially present.

Runup values of Saville (1955) are maximum values, although most studies tend to use average values. In cases of equal wave conditions (i.e., same  $d_g/H'_0$  and  $H'_0/gT^2$  values), the larger toe depths in Saville's tests generally gave larger relative runup. The apparent scale effects are large in some cases, with the larger depths giving relative runup values as much as 45 percent greater than the smaller depth. However, the limited data did not exhibit consistent trends when analyzed. Much of the apparent scale effect may result from (a) use of maximum runup rather than the average, (b) reporting runup values to the nearest foot in prototype, and (c) effects of differing relative bottom slope lengths ( $\ell/L$ ) for the different toe depths.

Saville (1956) conducted more extensive testing, and again varied the toe depths. Possible scale effects are noticed in some cases when the data are plotted for equal values of  $d_g/H'_0$  and  $H'_0/gT^2$ . However, the percentage difference in runup for the two toe depths is much less than in the earlier tests. The differences between results obtained in the two water depths did not seem to warrant separation of the data by depth (i.e., according to scale) and beach-slope length, and thus the smooth-slope runup curves given previously are derived in certain cases for data of different water depths but for the specific dimensionless wave conditions noted. For this reason also, the data points for  $R_e = 3.9 \times 10^4$  and  $R_e = 1.1 \times 10^5$  in Figure 48 are the same, having been determined from the smooth-slope curves (Fig. 22).

The tests of Hudson, Jackson, and Cuckler (1957) were limited in the range of wave steepnesses. For  $d_g/H'_0 \approx 1.5$ , essentially only two wave steepnesses were tested,  $H'_0/gT^2 \approx 0.0067$  and  $0.010$ . Variations in beach-slope length were also tested for these wave conditions. For each geometrical arrangement and for constant  $d_g/H'_0$ , only two runup values are available, and the values in Figure 48 are interpolated from the applicable pairs of data; i.e., the values in Figure 48 for the 1 on 3 slope are based on two relative beach-slope lengths, each of which was subjected to two different incident wave steepnesses, for a total of four test conditions. The 1 on 6 slope values are based on three different relative beach-slope lengths, using two different scales (different toe depths) for a total of six test conditions.

The range of runup values for each  $H'_0/gT^2$  value at  $R_e = 9.0 \times 10^4$  in Figure 48 is caused by the differences in relative beach-slope length. For the 1 on 3 slope, the lower runup values are associated with the longer slope length,  $\ell$ , as expected, and that slope length is the same (in relative terms) as used for the large scale ( $R_e = 3.75 \times 10^6$ ). For the 1 on 6 slope, the higher runup values at  $R_e = 9.0 \times 10^4$  are associated with the longer slope length,  $\ell$ , which is not the expected result; however, these runup values are essentially the same as obtained

at  $R_e = 3.75 \times 10^6$  by Saville (1958). Hudson, Jackson, and Cuckler (1957) tested a 1 on 6 slope at a larger scale ( $R_e = 2.12 \times 10^5$ ) using a beach-slope length,  $\ell$ , relatively longer than used in tests at either  $R_e = 9.0 \times 10^4$  or  $R_e = 3.75 \times 10^6$ , yet the relative runup is higher at  $R_e = 2.12 \times 10^5$  than for either smaller or larger scales. Thus, the data of Hudson, Jackson, and Cuckler give mixed results which are certainly a result of the limited data available, the beach-slope effects, and the different experimental equipment and techniques.

To better model slope roughness, Saville (1958, 1960) also conducted large-scale testing in addition to that given in Table 20. The small-scale ( $R_e = 1.19 \times 10^5$ ) test structures had plywood surfaces like the large-scale tests ( $R_e = 3.75 \times 10^6$ ). The large-scale plywood slope was coated with one layer of 0.4-millimeter sand, which was expected to more closely model the roughness of the small-scale tests, and was considered to be more representative of prototype situations. Because of time limitations, only three wave conditions were tested on the 1 on 3 slope:  $H_0^1 \approx 1.65$  meters (5.4 feet) and  $T = 7.87$  seconds;  $H_0^1 \approx 0.58$  meter (1.9 feet) and  $T = 16.0$  seconds;  $H_0^1 \approx 1.16$  meters (3.8 feet) and  $T = 3.75$  seconds. Results are given in Table 21.

Table 21. Large-scale tests of runup on smooth slope roughened with one layer of 0.4-millimeter sand; 1 on 3 structure slope.

$d_s/gT^2$	$H_0^1/gT^2$	Small scale, smooth $d_s = 0.12$ m (0.4 ft)	Large scale, roughened $d_s = 1.2$ m (4.0 ft)	$(R/H_0^1)_{large}$
		$R/H_0^1$	$R/H_0^1$	$(R/H_0^1)_{small}$
0.000485	0.00023	6.20	6.067	0.98
0.00201	0.00270	2.33	2.49	1.07
0.0088	0.00845	1.44	1.70	1.18

Correction curves for runup scale effects applicable to a range of structure slopes were developed by Saville (see U.S. Army, Corps of Engineers, Coastal Engineering Research Center, 1977). A similar development is given here with some modifications, but runup data used are restricted to that of Saville (1958, 1960) because of the similar test conditions.

Basic scale-effect correction factors may be obtained from Table 20 for smooth slopes, without considering the roughness test results given in Table 21. Thus, for  $H_0^1/gT^2 \geq 0.003$ , the average ratios of large-scale runup to small-scale runup,  $k$ , are 1.25 and 1.155 for the 1 on 3 and 1 on 6 slopes, respectively (i.e., increases of 25 and 15.5 percent). These two values are reduced by applying the results from the 1 on 3 roughened slope in Table 21 as follows. After the 1 on 3 slope was roughened with a sand layer, large-scale runup for two wave conditions ( $H_0^1/gT^2 \geq 0.0027$ ) was larger than small-scale runup by the factors 1.07 and 1.18 (7 and 18 percent). When compared with the runup results for the same wave conditions in Table 20, the percentage increase of large-scale runup on the roughened slope is shown to be approximately one-half (0.48 or 48 percent) of that for large-scale runup on a smooth slope (i.e., 7 versus 15 percent, and 18 versus



37 percent). The 48-percent value is then applied to the average values (25 and 15.5 percent) given above for the 1 on 3 and 1 on 6 smooth slopes. The resulting percentage increases applied to small-scale smooth-slope runup values to estimate runup on large-scale smooth slopes (prototype roughness) are 12 and 7.4 percent for the 1 on 3 and 1 on 6 slopes, respectively (i.e.,  $k = 1.12$  and  $k = 1.074$ ). The value of 1.074 for the 1 on 6 slope was determined by assuming that the roughness reduction is the same for the 1 on 3 slope.

Saville (1960) notes that earlier tests showed no scale effect for a 1 on 15 sand slope; thus,  $k = 1.0$  for the 1 on 15 slope. The three  $k$  values derived for the three slopes are plotted in Figure 49 and connected by a curve. Although no data are available for steeper slopes, the curve is extended to reach a maximum  $k$  value of 1.14 at  $\cot \theta = 1.25$ . A maximum value of  $k$  is reasonable and, in fact, a decrease is likely for very steep slopes because, for a given incident wave, the length of structure slope covered by the uprushing water becomes relatively small; also, the wave would likely be a surging wave rather than a breaking wave.

The scale-effect corrections in the SPM have one curve labeled "H = 1.5' to 4.5'," which is similar to the curve in Figure 49. The second curve is not based on data, but was suggested for larger wave heights. After a review of Figure 48, it is recommended that the curve in Figure 49 be applied to all wave heights until further testing warrants a change, based on the following reasoning. Wave heights larger than those tested would require larger Reynolds numbers if the same wave conditions were tested as in Figure 48. However, any increase in  $R/H'_0$  with increasing Reynolds numbers beyond what has been tested appears unlikely. Because of the relatively constant values of  $R/H'_0$  for the 1 on 6 slope for  $Re \geq 2.1 \times 10^5$  and because the large variation in 1 on 3 slope runup values at low  $Re$  numbers includes values as high as those at large  $Re$  numbers, a "critical" Reynolds number appears to be in the range  $2 \times 10^5 < (Re)_c < 4 \times 10^5$  for low  $d_s/H'_0$  values such as  $d_s/H'_0 = 1.5$ . The critical Reynolds number is a value beyond which relative runup would not increase for increasing Reynolds numbers.

The values for the lowest wave steepness ( $H'_0/gT^2 < 0.003$ ) in Table 21 suggest that no scale-effect correction is necessary for waves of low steepness if the slope roughness is properly modeled. For low wave steepnesses in Table 20 (1 on 3 slope), not all of the  $k$  values are small and some scale effect may remain after the slope roughness is properly modeled. The 1 on 6 slope (Table 20) has even larger  $k$  values for the low wave steepnesses tested, and, again, proper modeling of slope roughness may not account for all of the scale effect. Therefore, Figure 49, derived principally for waves of higher steepnesses, is also recommended for use in the low wave steepness range as an estimate. The values in Figure 49 are replotted in Figure 50, and the curve is extended over steeper slopes up to and including a vertical wall.

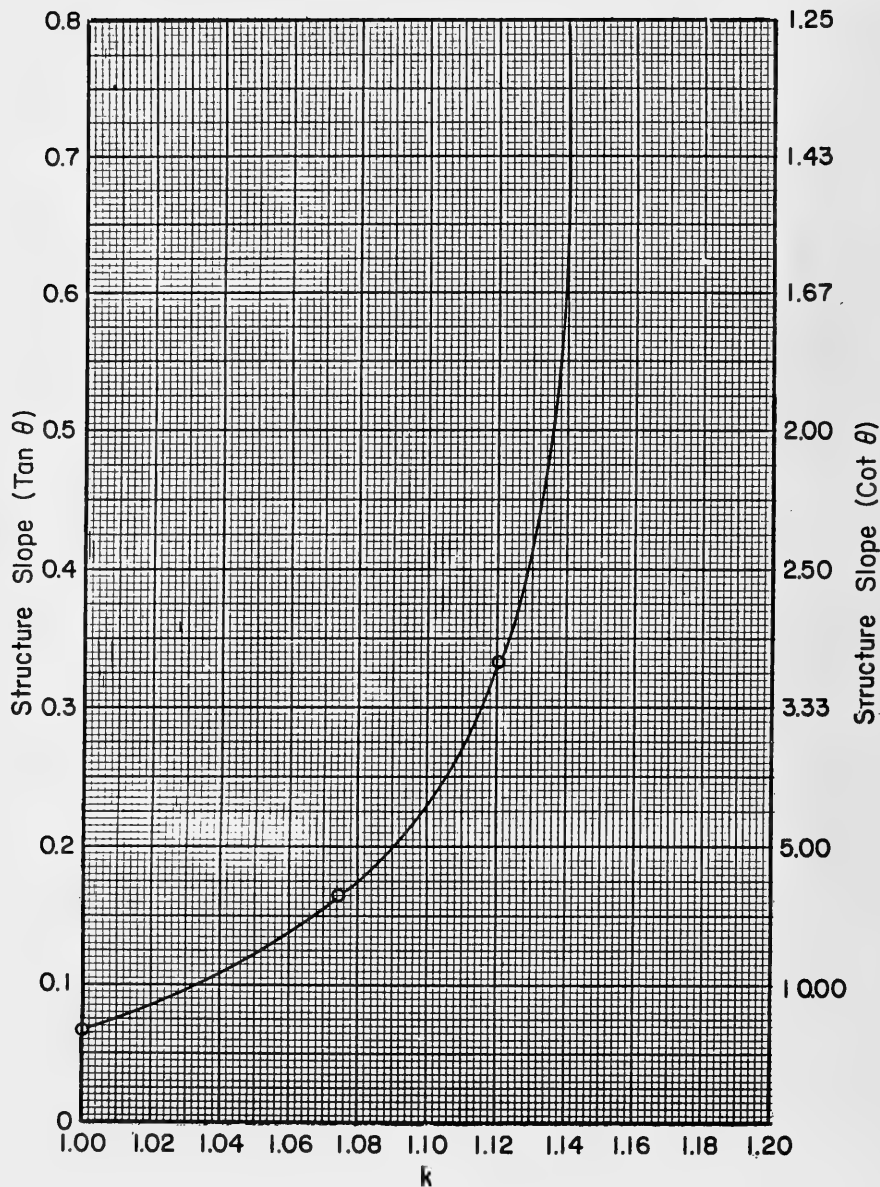

Figure 49. Correction factor,  $k$ , for scale effects in runup on smooth slopes,  $\cot \theta > 1.25$ .

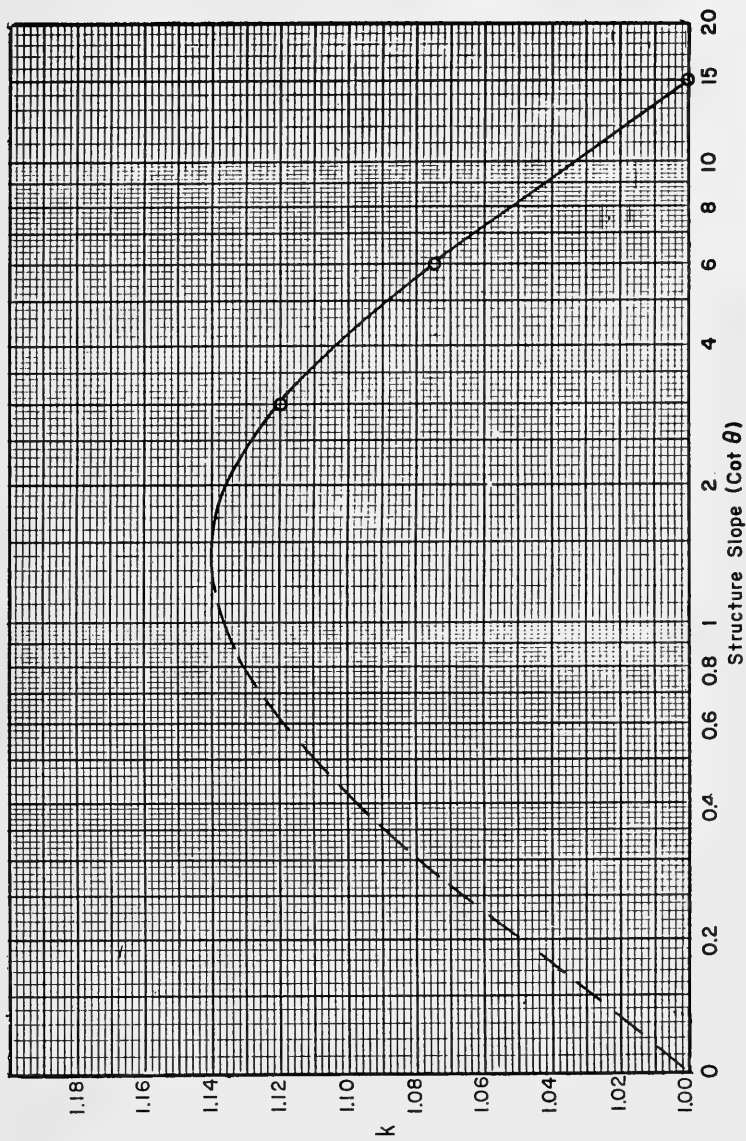

Figure 50. Runup scale-effect correction factor,  $k$ , replotted from Figure 49 and extrapolated for all smooth slopes.

Many questions concerning runup scale effects are left unanswered by the available data. Steep structure slopes (including vertical walls) have not been tested; scale effects may be negligible when the structure is fronted by a horizontal bottom but may be appreciable when fronted by a sloping bottom, often resulting in high relative runup. Corrections indicated by the roughened slope testing (very limited) may not be applicable over a wide range of wave conditions. The correction coefficient has a value of 1.0 at  $\cot \theta = 15$ . The curve would have a different shape if, for example, the correction coefficient for  $\cot \theta = 10$  were also 1.0, but test results are not available for additional slopes. No large-scale testing was conducted with a horizontal or gently sloping bottom fronting the structure where different scale effects might well be expected. Applicability of Figure 49 for all wave conditions (all  $d_s/H'_0$  and  $H'_0/gT^2$ ) is not clear, nor is it expected. Scale effects would be expected to be closely related to the presence (or absence) of a relatively thin sheet or jet of water which runs up the slope. The water would be greatly affected by roughness elements and its presence would be a function of incident wave conditions.

New experimental work directed at the above problems would certainly clarify some points. However, until further testing warrants changes, Figure 50 is recommended for use in determining scale effects in the design of smooth structure slopes.

#### 4. Rough-Slope Scale Effects.

Little information is available concerning scale effects in runup on rubble slopes. The study by Dai and Kamel (1969) is perhaps the most applicable but it was only for a rubble-mound structure with a 1 on 1.5 slope. Dai and Jackson (1966) measured runup on a rubble-mound breakwater at two scales, but these were rather small model-to-prototype scales of 1:50 and 1:100. Runup experiments on ripped slopes have not generally been designed to determine scale effects, although Hudson and Jackson (1962) included two different water depths (or scales) while measuring runup on a 1 on 2 slope. Most frequently, tests have been conducted at a single scale (including large scales) for rather limited conditions. In such cases, comparisons between scales can be made only for comparable test conditions. Such comparisons between independent experiments are uncertain because of unknown factors, such as experimental methods and structure differences.

Dai and Kamel (1969) tested a quarystone-armored, rubble-mound structure with a cross section similar to that tested by Hudson (1958). Only one slope was used,  $\cot \theta = 1.5$ . Three different water depths (see Table 19) were used, and these can be given in terms of the Reynolds number:  $Re = 4.69 \times 10^5$ ,  $1.33 \times 10^6$ , and  $2.72 \times 10^7$ . Quarystones considered to be either smooth or rough were used in the various tests. The set of runup data for smooth quarystones, and  $Re = 1.33 \times 10^6$ , appears to have the same wave conditions and runup as part of the data given by Hudson (1958). This particular data set has lower runup overall than for any other set of data given by Dai and Kamel when specific wave conditions are compared.

Dai and Kamel concluded that their tests gave inconclusive results regarding scale effects in runup. However, when the data are compared for specific wave conditions, some scale effects seem applicable to the rubble-mound structure. Results are given in Table 22 where ratios of runup for  $d_s/H'_0 = 4.0$  and  $5.0$  are combined and averaged for approximately  $0.0007 < H'_0/gT^2 < 0.017$ . The three high values of runup for the large scale at  $H'_0/gT^2 \approx 0.014$  appeared questionable and not included in the derivation of the table.

Table 22. Scale effects for quarrystone rubble mound with core much below SWL ( $\cot \theta = 1.5$ ); (after Dai and Kamel, 1969).

$d_s/H'_0$	$\frac{R(\text{large scale})^1}{R(\text{medium scale})^2}$	$\frac{R(\text{large scale})^1}{R(\text{small scale})^3}$
4.0 and 5.0	1.06	1.10

<sup>1</sup>Large scale:  $R_e = 2.72 \times 10^7$ , where  $R_e = \sqrt{gd_s}d_s/v$ .

<sup>2</sup>Medium scale:  $R_e = 1.33 \times 10^6$ .

<sup>3</sup>Small scale:  $R_e = 4.69 \times 10^5$ .

Dai and Kamel's (1969) data give runup values considerably higher than Hudson's (1958) data (approximately 30 percent higher at the same scale), even when all of Hudson's data are included, yet the runup data in the two studies appear consistent within each report. Thus, most of the difference is apparently due to differences in experimental procedures rather than scale effect; some of the difference certainly is in the difficulty of measuring runup on rubble slopes. However, Dai and Kamel's results for the large-scale rough quarrystone are surprisingly similar to results of Saville (1962) who tested a large-scale, three-layer, impermeable riprap structure with a 1 on 1.5 slope. Dai and Kamel's results also seem comparable with trends of Ahrens' (1975a) data (Figs. 40 and 41), although his  $H'_0/k_p$  values were slightly larger ( $H'_0/k_p = 3.15$  compared to  $H'_0/k_p = 2.5$  and  $2.7$  at  $d_s/H'_0 = 5.0$ ).

Because the runup data of Dai and Kamel appear high in relation to other testing, Hudson's runup values are recommended; however, because Dai and Kamel's runup data appear internally consistent, the scale correction value derived from their data is adopted. Thus, the 6-percent correction (i.e., correction factor of 1.06) in Table 13 is recommended for application to the steep structure slope parts of the rubble-mound curves in Figures 25, 26, and 27 derived from Hudson's data.

Dai and Kamel (1969) also tested runup on quadripods. The rubble-mound cross section was more conventional, with the top of the core located approximately at the SWL. The quadripod tests were also performed on rough and smooth armor unit types, as in the quarrystone

tests. Unfortunately, neither the largest nor smallest scales were tested simultaneously for perhaps more than two equivalent test conditions. Most of the comparisons must be made separately between the small and medium scales, and then between the medium and large scales. The comparisons for the quadripods suggest that there is less scale effect than for quarystone. Results are given in Table 23, combining values for both rough and smooth quadripods.

Table 23. Scale effects for quadripod rubble mound ( $h_c/d_s \approx 1.1$ ;  $\cot \theta = 1.5$ ) (after Dai and Kamel, 1969).

$d_s/H'_0$	$\frac{R_{(large\ scale)}^1}{R_{(medium\ scale)}^2}$	$\frac{R_{(medium\ scale)}^2}{R_{(small\ scale)}^3}$
4.0, 5.0, 8.0	$\approx 1.025$	$\approx 1.09$

<sup>1</sup>Large scale:  $R_e = 2.72 \times 10^7$ , where  $R_e = \sqrt{gd} d_s/v$ .

<sup>2</sup>Medium scale:  $R_e = 1.33 \times 10^6$ .

<sup>3</sup>Small scale:  $R_e = 4.69 \times 10^5$ .

A greater increase is apparent between the small and medium scales than between medium and large. The tests of Jackson (1968a) were conducted at the same scale as the "medium" scale of Dai and Kamel (a few of Dai and Kamel's test conditions and results are the same as given by Jackson). Thus, minimal scale correction ( $k \approx 1.03$ ) appears necessary for the steep structure slopes tested by Jackson.

Dai and Jackson (1966) conducted tests on a rubble-mound breakwater with 1 on 2 structure slope, fronted by a gently sloping beach representative of the Dana Point, California, project. This structure was tested at model-to-prototype scales of 1:5, 1:50, and 1:100; toe depths were basically 2.16, 0.18, and 0.09 meters (7.1, 0.6, and 0.3 feet) respectively, although depths were varied somewhat at each scale. However, evaluation of scale-effect differences is not possible for two reasons: (a) the large-scale runup tests were very limited; only about three runup values are available for comparison; and (b) the runup is highly variable as measured in the two smaller scale tests; in many cases the medium scale had lower runup than the small scale, and vice versa. Trends in values of  $R/H'_0$  for constant  $d_s/gT^2$  but varying  $H'_0/gT^2$  are so inconsistent that further analysis is not possible.

Few studies are available for evaluation of scale effects on riprap slopes. Large-scale tests have been conducted, but the test conditions are only comparable to those of small-scale tests for restricted conditions. Hudson and Jackson's (1962) small-scale tests of riprap used two different water depths (scales):  $d_s = 0.30$  meter (1 foot) and  $d_s = 0.51$  meter (1.67 feet). The test results for these two depths are roughly equivalent. Ahrens (1975a) conducted large-scale testing of riprap on slopes of  $\cot \theta = 2.5, 3.5, \text{ and } 5$ . His  $H'_0/k_r$  ratio at  $d_s/H'_0 = 5.0$  was somewhat larger than that tested by Hudson and Jackson; however, the

$H'_0/k_r$  values were close and would be expected to have only negligible effect on comparison of the two experiments. The data of Hudson and Jackson and of Ahrens can be compared for  $\cot \theta = 2.5$  or  $3$ , as these conditions overlap, when values are interpolated between experimental conditions. For  $d_g/H'_0 = 5.0$ , Ahrens' runup data, for both  $\cot \theta = 3$  and  $2$  (as extrapolated), are slightly lower than that by Hudson and Jackson. Since Hudson and Jackson had the smaller  $H'_0/k_r$  value which represents a larger roughness, the results are not quite as expected and the comparison is inconclusive regarding scale effects. The runup results of Ahrens should be considered as of prototype scale and used without further correction.

Saville (1962) tested a 1 on 1.5 slope with three layers of riprap at a large scale ( $d_g = 4.57$  meters (discussed previously in Sec. V,2,a)). There are apparently no small-scale riprap test results that are comparable to Saville's tests. His results are given in this study as 'r' values from which approximate runup on riprap can be determined using the smooth-slope curves (Sec. V,1,b). Since no small-scale tests are available for comparison of scale effects, Saville's results would be applicable as large-scale values.

In summary, the runup scale-effect correction factor,  $k$ , for rubble-mound structures of the type tested by Hudson (1958) (low core height) is given in Table 22; i.e.,  $k \approx 1.06$  for steep structure slopes tested at  $R_e = 1.33 \times 10^6$ , and applies to Figures 25, 26, and 27 derived from Hudson's data. For  $R_e = 4.69 \times 10^5$ ,  $k \approx 1.10$  for steep structure slopes. These factors are also recommended for quarystone rubble-mound structures with core heights at or above SWL, such as tested by Jackson (1968).

Rubble-mound structures armored with concrete armor units of a highly permeable design would be expected to have a runup scale effect similar to that for quadripods (Table 23). A value of  $k \approx 1.03$  would apply to the appropriate tests by Jackson (1968) (see test results in Table 11).

Scale-effect results for quarystone riprap slopes are inconclusive; however, several sets of large-scale test data are available and should be used directly, if possible (Saville, 1962; Ahrens, 1975a). The tests of Hudson and Jackson (1962), when compared to large-scale tests, indicate that little, if any, scale correction is required for runup results derived from small-scale riprap ( $R_e \geq 4.7 \times 10^5$ ); however, comparable wave conditions and structure designs are not available over the full range of small- and large-scale tests.

Runup scale effects on rubble structures fronted by a sloping beach are not available. Until further studies are conducted, the values given above are recommended for application to tests of small-scale structures fronted by sloping beaches.

The corrections given here are derived for structures with steep slopes. Scale corrections for flatter slopes would be expected to diminish in a manner similar to that for smooth slopes (Fig. 50), but the correction factor of 1.0 might well be reached for some slope on the order of  $\cot \theta = 5$  (or even steeper).

### 5. Example Problems.

\* \* \* \* \* EXAMPLE PROBLEM 12 \* \* \* \* \*

GIVEN: Runup, uncorrected for scale effects, was determined in example problem 4 for the following conditions: smooth structure slope;  $\cot \theta = 3$ ;  $\cot \beta = 90$ ;  $H = 2.5$  meters at  $d = 10$  meters;  $T = 8$  seconds;  $d_g = 7.5$  meters. Then,  $R/H'_0 = 2.0$  and  $R = 5.4$  meters.

Find: Determine the full-scale runup.

SOLUTION: From Figure 50, for a structure slope of  $\cot \theta = 3$ , the run-up correction factor,  $k$ , is determined to be 1.12. The corrected relative runup is then

$$\frac{R}{H'_0} = (2.0)(1.12) = 2.24$$

and

$$R = (2.24)(H'_0)$$

$$R = (2.24)(2.68) = 6.0 \text{ meters .}$$

The correction factor,  $k$ , may also be applied directly to the uncorrected absolute value of runup,  $R$ ; then,

$$R = (5.4)(k)$$

$$R = (5.4)(1.12) = 6.0 \text{ meters .}$$

\* \* \* \* \*  
 \* \* \* \* \* EXAMPLE PROBLEM 13 \* \* \* \* \*

GIVEN: Relative runup has been determined for a rubble-mound structure which has quarystone armor units. The top elevation of the core is below SWL. Structure slope is  $\cot \theta = 2$ ;  $\beta = 0$ .  $R/H'_0$  is based on model experiments for  $R_0 \approx 1.3 \times 10^6$ .

FIND: Determine the appropriate scale-effect correction factor,  $k$ .



SOLUTION: These conditions are similar to those tested by Hudson (1959). From Table 22,  $k \approx 1.06$  for a slope of  $\cot \theta = 1.5$ ; although  $k$  is expected to decrease for more gentle slopes,  $\cot \theta = 2$  is close to  $\cot \theta = 1.5$ , and  $k = 1.06$  is used. Therefore,

$$\left(\frac{R}{H'_0}\right)_{corrected} = (k)\left(\frac{R}{H'_0}\right)_{small\ scale}$$

$$\left(\frac{R}{H'_0}\right)_{corrected} = (1.06)\left(\frac{R}{H'_0}\right)_{small\ scale}$$

\*\*\*\*\*

\*\*\*\*\* EXAMPLE PROBLEM 14 \*\*\*\*\*

GIVEN: Riprap slope,  $\cot \theta = 3$ ;  $\beta = 0$ ;  $d_s/H'_0 \approx 4.5$ ;  $H'_0/gT^2 \approx 0.0085$ .

FIND: Determine the runup,  $R$ , for a structure in a depth of 8 meters (26.2 feet).

SOLUTION: Stone size is not given; however, a large value of  $H'_0/k_p$  is assumed (e.g.,  $H'_0/k_p \leq 4$ ), thus using conditions close to maximum for riprap stability and for which runup may be relatively large because of the large wave to stone size. From Figure 40, for  $\cot \theta = 3$  and  $H'_0/gT^2 = 0.0085$ ,  $R/H'_0 \approx 0.88$ .

$$R = \left(\frac{R}{H'_0}\right) \times \frac{1}{(d_s/H'_0)} \times d_s$$

$$= (0.88) \times \left(\frac{1}{4.5}\right) \times 8$$

$$R = 1.56 \text{ meters (5.1 feet)}$$

Scale-effect correction factor,  $k$ , is 1.0 because Figure 40 is based on large-scale tests. Thus,  $R \approx 1.56$  meters is the full-scale runup.

## VII. RECOMMENDATIONS FOR FUTURE RESEARCH

In this study, a number of reports have been reviewed which, collectively, provide a large amount of valuable data; however, data gaps remain and future research should be directed at filling those gaps. Recommendations for planning and data collection are:

(a) For each wave period and water depth used, a wide range of wave heights is desirable to discern trends in relative runup for the particular conditions. Incident wave heights would best be measured in the uniform depth part of the wave flume. When testing structures fronted by either horizontal or sloping bottoms,  $d_s/gT^2$  should

preferably range from 0.08 (deep water) to values in the shallow-water range ( $d_s/gT^2 < 0.0016$ );  $d_s/H'_0$  should range from a large value (such as 15) to as small a value as possible. The range of  $d_s/H'_0$  selected should be low enough to include, on sloping bottoms, waves which are breaking seaward of the structure toe. (Note that wave steepness is determined when  $d_s/gT^2$  and  $d_s/H'_0$  are specified.) Waves incident to a structure sited on a horizontal bottom should be of the maximum wave steepness possible.

(b) Auxiliary data to be obtained include the observation of whether or not a wave is breaking for the specific incident wave conditions. The location of breaking (even when the wave breaks at a point over the structure slope) should be noted, and the breaking wave height should be determined.

(c) Tests of runup on structures fronted by gentle bottom slopes, e.g., 1 on 20 to 1 on 50 or flatter, are desirable. A large amount of runup data has been obtained for smooth slopes fronted by 1 on 10 bottom slopes, but such a steep bottom slope is unrealistic for most applications. Emphasis should be given to the range  $1 \leq d_s/H'_0 \leq 3$ , for which waves would be expected to break near the structure toe, and where maximum runup would be expected. For such tests, measurement of the breaking wave height, along with runup, would be extremely useful, since, in conjunction with the corresponding wave height in deeper water, a breaker height index ( $H_b/H'_0$ ) could be developed. This index would then be applicable for waves approaching a structure. Breaker height index curves in the SPM are derived from tests conducted on uniform slopes which extend from above water level to the maximum depth. Jackson (1968b) reported test results of maximum breaking and nonbreaking wave heights incident to a rubble-mound structure sited on sloping and on horizontal bottoms. The breaker heights observed by Jackson are lower than calculated from the design curves; however, calculation of the deepwater variables (and thus the breaker height index) from the available data is not possible.

(d) Testing of runup on rubble-mound and riprap structures sited on sloping bottoms has been limited; however, this arrangement, in conjunction with waves breaking at the structure toe, is the design condition in many instances. Additional testing is required. A range of bottom slopes and structure slopes is desirable, and a rather steep rubble-mound slope (e.g.,  $\cot \theta = 1.5$ ) should be included. Low  $d_s/H'_0$  values ( $1 \leq d_s/H'_0 \leq 3$ ) would ensure that data are acquired for waves which are breaking at or in front of the structure toe.

(e) Testing the effect of beach-slope length is recommended, but the importance of the length is expected to diminish with gentler bottom slopes. Such testing could be accomplished by holding conditions constant at the structure toe (e.g., constant  $d_s$ ,  $d_s/H'_0$ , and  $H'_0/gT^2$ ) and varying the length of beach slope (i.e., varying the depth,  $d$ , at the

toe of beach slope). Holding  $d_s$  constant would keep the model at the same scale (same Reynolds number) to allow isolation of the effects of slope length.

(f) Testing of different armor unit sizes, with other conditions remaining the same, would allow a better evaluation of the effects of relative roughness. As a minimum, armor units should be tested at conditions close to their stability limits at each of several  $d_s/H'_0$  values (e.g., 1.0, 1.5, 3.0, 5.0, etc.).

(g) Many small-scale runup tests have been conducted for structures sited on horizontal bottoms. Large-scale tests of runup on smooth structures sited on horizontal bottoms have not been conducted although runup experiments have been conducted at large scales using riprap slopes fronted by a horizontal bottom. Additional tests of both smooth slopes and slopes protected with armor units other than stone would be useful in evaluating scale effects. These tests would best be conducted in the range  $2.5 \leq d_s/H'_0 \leq 8$ . Similarly, large-scale tests of runup on smooth structure slopes fronted by a sloping beach have been obtained for limited conditions. Additional tests would be useful if conducted on both smooth and rubble slopes, and if a wide range of wave steepnesses is tested for each of several  $d_s/H'_0$  values ( $1 \leq d_s/H'_0 \leq 5$ ). Evaluation of scale-effect tests requires use of identical geometries, including the length of beach slope. Tests at intermediate Reynolds numbers may help determine the minimum model scale necessary for prediction of prototype runup. Intermediate values would be on the order of  $4 \times 10^5 < R_e < 2 \times 10^6$  for structures on sloping beaches, or  $2 \times 10^6 < R_e < 1 \times 10^7$  for structures on horizontal bottoms.

### VIII. SUMMARY

Analysis of laboratory runup test results pertaining to steep structures and monochromatic waves was used to develop runup equation (8) for smooth slopes fronted by horizontal bottoms:

$$\frac{R}{H'_0} = (\cot \theta)^{-1.04} (4.23) (10)^2 (q-1) \left( \frac{H'_0}{gT^2} \right)^{q-1} \quad \text{for } \cot \theta \geq 2 .$$

Values of  $q$  are determined from Figure 5. Equation (8) gives runup for waves breaking on the structure slope; nonbreaking waves will have lower relative runup for a given wave steepness,  $H'_0/gT^2$ . Thus, equation (8) is conservative and gives  $(R/H'_0)_{max}$  for a given slope and wave steepness. The demarcation between breaking and nonbreaking waves is a function of relative depth and wave steepness. Waves meeting the condition of equation (5) are considered breaking regardless of relative depth; equation (5), with  $H$  replaced by  $H'_0$ , is

$$\frac{H'_0}{gT^2} \geq 0.031 \tan^2 \theta .$$

For lesser steepness, some waves may still be breaking. Figure 4 shows minimum values of  $H'_0/gT^2$  for breaking waves as a function of  $d_s/gT^2$ . The flow chart in Figure 6 describes use of the equations. Runup of nonbreaking waves on a structure fronted by a horizontal bottom, together with breaking wave runup (if desired), may be obtained by using the smooth-slope empirical runup curves in Figures 14, 15, and 16. These curves are modified from those in the SPM.

Runup on smooth structures fronted by a sloping 1 on 10 beach should be determined by use of Figures 14 to 23. The beach-slope length is an important variable. The runup curves were developed from results of tests where the beach-slope horizontal length was equal to or greater than one-half the wavelength at the toe of the sloping beach. As the relative beach-slope length ( $\ell/L$ ) decreases, for a given  $d_s/H'_0$  and  $H'_0/gT^2$ , relative runup would be expected to increase (unless the wave breaks in front of the structure toe) to a maximum relative runup equivalent to that obtained for the given  $d_s/H'_0$  in the presence of a horizontal beach.

Maximum absolute runup,  $R$ , for a given *wave period* will be produced for the maximum wave steepness possible unless the wave breaks before reaching the structure. If a wave of given period breaks at the higher steepness values, maximum runup will be produced by a wave which begins breaking near the structure toe. The smooth-slope runup curves (Figs. 14 to 23) give data for constant  $d_s/H'_0$  values. For a given  $d_s/H'_0$  value and constant  $d_s$ , higher runup,  $R$ , will occur at lower wave steepnesses,  $H'_0/gT^2$ . Conversely, for a given wave steepness and depth,  $d_s$ , higher runup will occur at the lower values of relative depth,  $d_s/H'_0$ . For structures on sloping beaches, runup,  $R$ , for a given wave steepness may be approximately the same for different  $d_s/H'_0$  values because of effects from the waves' breaking. Design wave conditions usually assume the design wave is associated with high wave steepnesses, but certain environments might have a design wave associated with low wave steepness. A range of wave conditions encompassing the selected design conditions needs to be evaluated to determine maximum runup. Most importantly, maximum absolute runup may not be coincident with the maximum relative runup for a given range of conditions.

Runup on rough slopes was developed in this study with emphasis on structure cross section, relative depth, and relative roughness. In cases where sufficient experimental data were available, relative runup was plotted in a manner analogous to the smooth-slope data; i.e.,  $R/H'_0$  versus  $\cot \theta$  for isolines of  $H'_0/gT^2$  and for specific  $d_s/H'_0$  and  $H'_0/k_p$  values. In all cases, also, the ratio between the rough-slope runup and smooth-slope runup,  $r$ , is given. The ratio  $r$  is given as  $r = f(H'_0/k_p, \theta)$ . Thus, for any given  $H'_0/k_p$  and  $d_s/H'_0$ ,  $r$  is an average of several values over a range of  $H'_0/gT^2$  and is expected to be a function of  $d_s/H'_0$  and  $H'_0/gT^2$ , but insufficient data exist to further develop the relationship. Runup for structures or wave conditions not tested may be estimated by using the equivalent smooth-slope

runup and the  $r$  value determined for a particular relative roughness. Since any one value of  $r$ , as given in this study, is an average, uncertainties in the prediction are expected to be generally  $\pm 10$  percent but may be as high as 25 to 30 percent.

Runup on rough slopes in cases where waves are breaking near the structure toe (low  $d_g/H'_0$  values) is a common design situation for which few experiments are available. The tests by Raichlen and Hammack (1974) and Palmer and Walker (1970) both indicated a value of  $r \approx 0.5$  for  $H'_0/k_r \approx 2.0$  and for 1 on 1.5 or 1 on 2 structure slopes fronted by gently sloping bottoms. This value of  $r$  is equal to or less than that determined for riprap slopes with thicker armor layers and with larger  $d_g/H'_0$  values, for which waves did not break in front of the structure. The result suggests that the available  $r$  values determined for larger  $d_g/H'_0$  values are applicable, although possibly high, to estimates of rough-slope runup for slopes and relative depths not tested but for which smooth-slope results are available. Further testing is necessary to clarify the relationships.

Scale effects were investigated, but the number of large-scale test results is limited. A correction curve for smooth slopes is given in Figure 50. Data for analyzing rough-slope effects are even more limited than for smooth slope. Tables 22 and 23 (both for  $\cot \theta = 1.5$ ) give suggested values for quarystone and quadripod rubble-mound structures. Scale corrections for both steeper and gentler slopes would be expected to be lower. Large-scale test results are available for riprap slopes (Figs. 40, 41, and 42) and, if applicable, are recommended for use without correction.

## LITERATURE CITED

- AHRENS, J.P., "Large Wave Tank Tests of Riprap Stability," TM-51, U.S. Army, Corps of Engineers, Coastal Engineering Research Center, Fort Belvoir, Va., May 1975a.
- AHRENS, J.P., "Wave Runup on a 1 on 10 Slope," MP 12-75, U.S. Army, Corps of Engineers, Coastal Engineering Research Center, Fort Belvoir, Va., Dec. 1975b.
- BUCCI, D.R., and WHALIN, R.W., "Runup Characteristics of Explosion-Generated Waves in Major Harbor Areas. Report 1: Wave Intrusion Into Monterey Harbor, California," TR N-69-4, U.S. Army Engineer Waterways Experiment Station, Vicksburg, Miss., 1969.
- BUCCI, D.R., and WHALIN, R.W., "Runup Characteristics of Explosion-Generated Waves in Major Harbor Areas. Report 2: Methodology for Conducting Runup Tests in a Distorted Model and Wave Intrusion into San Diego Bay, California," TR N-69-4, U.S. Army Engineer Waterways Experiment Station, Vicksburg, Miss., 1970.
- DAI, Y.B., and JACKSON, R.A., "Designs for Rubble-Mound Breakwaters, Dana Point Harbor, California," TR 2-725, U.S. Army Engineer Waterways Experiment Station, Vicksburg, Miss., 1966.
- DAI, Y.B., and KAMEL, A.M., "Scale Effect Tests for Rubble-Mound Breakwaters," RR H-69-2, U.S. Army Engineer Waterways Experiment Station, Vicksburg, Miss., 1969.
- GRANTHEM, K.N., "Wave Runup on Sloping Structures," *Transactions of the American Geophysical Union*, Vol. 34, No. 5, 1953.
- HERBICH, J.B., SORENSEN, R.M., and WILLENBROCK, J.H., "Effect of Berm on Wave Runup on Composite Beaches," *Journal of the Waterways and Harbors Division*, Vol. 89, No. WW2, May 1963.
- HOSOI, M., and MITSUI, H., "Wave Runup on Sea Dikes Located in the Surf Zone or on the Shore," *Coastal Engineering in Japan*, Vol. 6, 1963.
- HUDSON, R.Y., "Design of Quarry-Stone Cover Layers for Rubble-Mound Breakwaters," R.R. No. 2-2, U.S. Army Engineer Waterways Experiment Station, Vicksburg, Miss., 1958.
- HUDSON, R.Y., "Laboratory Investigation of Rubble-Mound Breakwaters," *Journal of the Waterways and Harbors Division*, Vol. 85, No. WW3, Sept. 1959.
- HUDSON, R.Y., ed., "Concrete Armor Units for Protection Against Wave Attack; Report of Ad Hoc Committee on Artificial Armor Units for Coastal Structures," Miscellaneous Paper No. H-74-2, U.S. Army Engineer Waterways Experiment Station, Vicksburg, Miss., 1974.

- HUDSON, R.Y., and DAVIDSON, D.D., "Reliability of Rubble-Mound Breakwater Stability Models," *Second Annual Symposium on Modeling Techniques*, 1975, pp. 1603-1622.
- HUDSON, R.Y., and JACKSON, R.A., "Design of Riprap Cover Layers for Railroad Relocation Fills, Ice Harbor and John Day Lock and Dam Projects," Miscellaneous Paper 2-465, U.S. Army Engineer Waterways Experiment Station, Vicksburg, Miss., 1962.
- HUDSON, R.Y., JACKSON, R.A., and CUCKLER, R.E., "Wave Runup and Over-Topping, Levee Sections, Lake Okeechobee, Florida," Technical Report No. 2-449, U.S. Army Engineer Waterways Experiment Station, Vicksburg, Miss., 1957.
- HUNT, I.A., Jr., "Design of Seawalls and Breakwaters," *Journal of the Waterways and Harbors Division*, Vol. 85, No. WW3, Sept. 1959.
- IRIBARREN CAVANILLES, R., and NOGALES y OLANO, C., "Protection des ports," Section II, Communication 4, *XVIIth International Navigation Congress*, 1949, pp. 31-80.
- IRIBARREN CAVANILLES, R., and NOGALES y OLANO, C., "The Critical Slope Between Incipient Breaking and Reflecting of Waves," Translation No. 50-2, U.S. Army Engineer Waterways Experiment Station, 1950; from *Talud Limite Entre la Rotura Y la Reflexion de las Olas*, Revista de Obras Publicas, Madrid, Feb. 1950.
- JACHOWSKI, R.A., "Interlocking Precast Concrete Block Seawall," *Proceedings of the Ninth Conference on Coastal Engineering*, 1964, pp. 504-517.
- JACKSON, R.A., "Design of Cover Layers for Rubble-Mound Breakwaters Subjected to Nonbreaking Waves," R.R. 2-11, U.S. Army Engineer Waterways Experiment Station, Vicksburg, Miss., 1968a.
- JACKSON, R.A., "Limiting Heights of Breaking and Nonbreaking Waves on Rubble-Mound Breakwaters," TR H-68-3, U.S. Army Engineer Waterways Experiment Station, Vicksburg, Miss., 1968b.
- KOH, R.C.Y., and Le MEHAUTE, B., "Final Report; Volume II: Wave Runup State of the Art," Report S-245 B, National Engineering Science Company, Pasadena, Calif., 1966.
- Le MEHAUTE, B., KOH, R.C.Y., and HWANG, L., "A Synthesis on Wave Runup," *Journal of the Waterways and Harbors Division*, Vol. 94, No. WW1, Feb. 1968.
- MCCARTNEY, B.L., and AHRENS, J.P., "Stability of Gobi Block Revetment to Wave Attack," TM-55, U.S. Army, Corps of Engineers, Coastal Engineering Research Center, Fort Belvoir, Va., Oct. 1975.

- MICHE, R., "Mouvements Ondulatoires de la Mer en Profondeur Constante ou Decroissante," *Annales des Ponts et Chaussées*, 114e Année, 1944.
- MICHE, R., "Le Pouvoir Reflechissant des Ouvrages Maritimes Exposes a l'Action de la Houle," *Annales des Ponts et Chaussées*, 121e, Année, 1951.
- NUSSBAUM, P.J., and COLLEY, B.E., "Dam Construction and Facing with Soil-Cement," Bulletin RD 010.01W, Portland Cement Association, Skokie, Ill., 1971.
- PALMER, R.Q., and WALKER, J.R., "Honolulu Reef Runway Dike," *Proceedings of the 12th Conference on Coastal Engineering*, 1970..
- RAICHLIN, F., "The Effect of Waves on Rubble-Mound Structures," *Annual Review of Fluid Mechanics*, Vol. 7, Annual Reviews, Inc., 1975, pp. 327-356.
- RAICHLIN, F., and HAMMACK, J.L., Jr., "Runup Due to Breaking and Non-breaking Waves," *Proceedings of the 14th Coastal Engineering Conference*, 1974.
- SAVAGE, R.P., "Wave Runup on Roughened and Permeable Slopes," *Journal of the Waterways and Harbors Division*, Vol. 84, No. WW3, May 1958.
- SAVAGE, R.P., "Laboratory Data on Wave Runup on Roughened and Permeable Slopes," TM-109, U.S. Army, Corps of Engineers, Beach Erosion Board, Washington, D.C., Mar. 1959.
- SAVILLE, T., Jr., "Laboratory Data on Wave Runup and Overtopping on Shore Structures," TM-64, U.S. Army, Corps of Engineers, Beach Erosion Board, Washington, D.C., Oct. 1955.
- SAVILLE, T., Jr., "Wave Runup on Shore Structures," *Journal of the Waterways and Harbors Division*, Vol. 82, No. WW2, Apr. 1956.
- SAVILLE, T., Jr., "Large-Scale Model Tests of Wave Runup and Overtopping, Lake Okeechobee Levee Sections," U.S. Army, Corps of Engineers, Beach Erosion Board, Washington, D.C., unpublished, 1958.
- SAVILLE, T., Jr., "Scale Effect in Wave Runup," American Society of Civil Engineers Convention, Boston, Mass., unpublished, 1960.
- SAVILLE, T., Jr., "Additional Wave Runup Curves," U.S. Army, Corps of Engineers, Beach Erosion Board, Washington, D.C., unpublished data in letter of transmittal, 1962.
- SHINOHARA, K., "Studies on the Characteristics of Breakers and Wave Runup on Smooth and Artificially Roughened Slopes," Report of the Research Institute for Applied Mechanics, No. 11, Kyushu University, Japan, 1958, pp. 31-50.



- SORENSEN, R.M., and WILLENBROCK, J.H., "A Study of the Effect of Horizontal Berm Variation on Wave Runup Upon a Composite Beach Slope," Project Report No. 35, Lehigh University, Fritz Laboratory, Bethlehem, Pa., 1962.
- TAKADA, A., "Estimation of Wave Overtopping Quantity over Sea-Walls," *Proceedings of the 14th Coastal Engineering Conference*, 1974.
- TALIAN, S.F., and VESILIND, P.A., "A Study of the Effect of Horizontal Berm Variation on Wave Runup upon a Composite Beach Slope with Depth of Water Equal to Berm Height," Project No. 35 (Supplement), Lehigh University, Fritz Engineering Laboratory, Bethlehem, Pa., 1963.
- TECHNICAL ADVISORY COMMITTEE ON PROTECTION AGAINST INUNDATION, "Wave Runup and Overtopping," Government Publishing Office, The Hague, The Netherlands, 1974.
- TOMINAGA, Y., HASHIMOTO, H., and SAKUMA, N., "Wave Runup and Overtopping on Coastal Dikes," *Proceedings of the 10th Coastal Engineering Conference*, 1966, pp. 364-381.
- U.S. ARMY, CORPS OF ENGINEERS, COASTAL ENGINEERING RESEARCH CENTER, "Shore Protection Planning and Design," TR-4, 3d ed., U.S. Government Printing Office, Washington, D.C., 1966.
- U.S. ARMY, CORPS OF ENGINEERS, COASTAL ENGINEERING RESEARCH CENTER, *Shore Protection Manual*, 3d ed., Vols. I, II, and III, Stock No. 008-022-00113-1, U.S. Government Printing Office, Washington, D.C., 1977, 1,262 pp.
- VAN DORN, W.G., "Runup Recipe for Periodic Waves on Uniformly Sloping Beaches," *Proceedings of the 10th Coastal Engineering Conference*, 1966, pp. 349-363.
- VAN DORN, W.G., Le MEHAUTE, B., and HWANG, L., "Final Report--Handbook of Explosion-Generated Water Waves; Vol. I--State of the Art," Report No. TC-130, Tetra Tech, Inc., Pasadena, Calif., 1968.
- VANONI, V.A., and RAICHLIN, F., "Laboratory Design-Studies of the Effect of Waves on a Proposed Island Site for a Combined Nuclear Power and Desalting Plant," Report No. KH-R-14, California Institute of Technology, Pasadena, Calif., 1966.
- WEBBER, N.B., and BULLOCK, G.N., "The Runup of Waves on Sloping Faces-- A Review of the Present State of Knowledge," *Proceedings of Dynamic Waves in Civil Engineering*, July 1970, pp. 293-314.

## BIBLIOGRAPHY

- ADAM, K.M., "A Model Study of Wave Runup on Smooth and Rough Slopes," M.S. Thesis, University of Manitoba, Winnipeg, 1963.
- AHRENS, J.P., "The Influence of Breaker Type on Riprap Stability," *Proceedings of the 12th Coastal Engineering Conference*, 1970, pp. 1557-1566.
- AHRENS, J.P., and McCARTNEY, B.L., "Wave Period Effect on the Stability of Riprap," *Proceedings of Civil Engineering in the Oceans/III*, Vol. 2, 1975, pp. 1019-1034.
- BATTJES, J.A., "Runup Distributions of Waves Breaking on Slopes," *Journal of the Waterways and Harbors Division*, Vol. 97, No. WW1, Feb. 1971, pp. 91-114.
- BATTJES, J.A., "Computation of Set-up, Longshore Currents, Runup and Overtopping Due to Wind-Generated Waves," Ph.D. Thesis, Delft University of Technology, The Netherlands, 1974.
- BOTTIN, R.R., CHATHAM, C.E., and CARVER, R.D., "Waianae Small-Boat Harbor, Oahu, Hawaii, Design for Wave Protection; Hydraulic Model Investigation," Technical Report H-76-8, U.S. Army Engineer Waterways Experiment Station, Vicksburg, Miss., 1976.
- BRUUN, P.M., and JOHANNESSON, P., "Discussion: Irregular Wave Action on Rubble-Mound Breakwaters," *Journal of the Waterways, Harbors and Coastal Engineering Division*, Vol. 98, No. WW1, Feb. 1972, pp. 113-118.
- DIEPHUS, J.G.H.R., et al., "Golven en Golfoploop" ("Waves and Wave Runup"), Report Deltacommission, Part 6, 1961, pp. 7-22.
- GORDON, A.D., "Breakwater Stability, Stage 1, Revetment, Botany Bay," Technical Report No. 72/11, The University of New South Wales, Water Research Laboratory, Manly Vale, Australia, 1972.
- GRANTHEM, K.N., "A Model Study of Wave Runup on Sloping Structures," Series 3, No. 348, University of California, Waves Research Laboratory, Berkeley, 1953.
- GUNBAK, A.R., "The Stability of Rubble-Mound Breakwaters in Relation to Wave Breaking and Run-Down Characteristics and to the  $\xi \sim tg \alpha \cdot T/\sqrt{H}$  Number," Ph.D. Thesis, University of Trondheim, The Norwegian Institute of Technology, Division of Port and Harbour Engineering, Trondheim, Norway, 1976.
- HENSEN, W., and FUHRBOTER, A., "Model Tests of Wave Runup on Elbe River Dykes at Finkenwerder," *Transactions of the Franzius Institute for Foundation and Hydraulic Engineering of the University of Hannover*, Germany, No. 21, 1962.

- HOSOI, M., and SHUTO, N., "Runup Height on a Single Slope Dike Due to Waves Coming Obliquely," *Coastal Engineering in Japan*, Vol. 7, 1964, pp. 95-99.
- HUNT, I.A., Jr., "Design of Seawalls and Breakwaters," U.S. Army, Corps of Engineers, U.S. Lake Survey, Detroit, Mich., 1958.
- IWAGAKI, Y., INOUE, M., and OHORI, K., "Experimental Study on the Mechanism of Wave Runup on Sloping Structures," *Proceedings of the 13th Conference on Coastal Engineering in Japan*, 1966, pp. 198-205.
- IWAGAKI, Y., SHIMA, A., and INOUE, M., "Effects of Wave Height and Sea Water Level on Wave Overtopping and Wave Runup," *Coastal Engineering in Japan*, Vol. 8, 1965, pp. 141-151.
- KATO, J., "Shapes of Shore Structures (Dikes) and Its Damping Effect for Wave Forces--Especially for Wave Runup and Wave Pressure," *Coastal Engineering in Japan*, Vol. 2, 1959, pp. 73-84.
- KATO, J., and SHIRAISHI, H., "Wave Runup on Dike," *Journal of the Agricultural Engineering Society*, Japan, Vol. 27, No. 4, 1959, pp. 186-189.
- KATO, J., and UEKITA, Y., "On the Wave Damping Effect of Block Mound Breakwater," *Transactions of the Japanese Society of Civil Engineers*, Vol. 1, 1969.
- KRAMER, J., "Design Criteria for North Sea Dikes," *Journal of the Waterways, Harbors and Coastal Engineering Division*, Vol. 97, No. WW4, Nov. 1971, pp. 703-719.
- Le MEHAUTE, B., SNOW, G.F., and WEBB, L.M., "Final Report; Volume I: Gravity Waves on Bottom Slopes," Report S-245A, National Engineering Science Company, Pasadena, Calif., 1966.
- MACHEMEHL, J.L., and HERBICH, J.B., "Wave Runup on Composite Beaches--Effect of Roughness," *Offshore Technology Conference*, Paper 1431, 1971, pp. 179-190.
- MERRIFIELD, E.M., and ZWAMBORN, J.A., "The Economic Value of a New Breakwater Armor Unit 'Dolos'," *Proceedings of the 10th Conference on Coastal Engineering*, 1966, pp. 885-912.
- MURAKI, Y., "Field Observations of Wave Pressure, Wave Runup and Oscillation of Breakwater," *Proceedings of the 10th Conference on Coastal Engineering*, 1966, pp. 302-321.
- NAGAI, S., and TAKADA, A., "Relations Between the Runup and Overtopping of Waves," *Proceedings of the 13th Coastal Engineering Conference*, 1972, pp. 1975-1992.

- NAKAMURA, M., ONISHI, R., and SASAKI, Y., "Wave Runup on Composite Slopes," *Bulletin of the National Research Institute of Agricultural Engineering*, No. 11, Japan, Mar. 1973.
- OUELLET, Y., "Considerations on Factors in Breakwater Model Tests," *Proceedings of the 13th Coastal Engineering Conference*, 1972, pp. 1809-1825.
- RETIEF, G., and VONK, A.P.M., "Breakwater Armour Units--Model Tests; Interim Report," Fisheries Development Corporation of South Africa, Ltd., Cape Town, May 1974.
- SATO, S., and KISHI, T., "Experimental Study of Wave Runup on Sea Wall and Shore Slope," *Coastal Engineering in Japan*, Vol. 1, 1958.
- SAVAGE, R.P., "Model Tests of Wave Runup for Hurricane Protection Project," *Bulletin*, Vol. 11, No. 1, U.S. Army, Corps of Engineers, Beach Erosion Board, Washington, D.C., 1957.
- SAVILLE, T., Jr., "Wave Runup on Composite Slopes," *Proceedings of the Sixth Conference on Coastal Engineering*, Council on Wave Research, 1958, pp. 691-699.
- SAVILLE, T., Jr., "An Approximation of the Wave Runup Frequency Distribution," *Proceedings of the Eighth Conference on Coastal Engineering*, 1962, pp. 48-59.
- SAVILLE, T., Jr., and CALDWELL, J.M., "Experimental Study of Wave Overtopping on Shore Structures," *Proceedings of the Minnesota International Hydraulics Convention*, Minneapolis, Minn., 1953, pp. 261-269.
- SAVILLE, T., Jr., McCLENDON, E.W., and COCHRAN, A.L., "Freeboard Allowances for Waves in Inland Reservoirs," *Journal of the Waterways and Harbors Division*, Vol. 88, No. WW2, May 1962, pp. 93-124.
- SIBUL, O., "Flow over Reefs and Structures by Wave Action," *Transactions of the American Geophysical Union*, Vol. 36, No. 1, 1955, pp. 61-71.
- TOMINAGA, M., and SAKUMA, N., "Wave Overtopping on Coastal Dikes," Report of the Public Works Research Institute, Ministry of Construction, Vol. 143, Sept. 1972.
- U.S. ARMY ENGINEER DISTRICT, LOS ANGELES, "General Design for Dana Point Harbor, Dana Point, California," Design Memorandum No. 1, Los Angeles, Calif., 1965.
- VYSOTSKIY, A.F., "Planning of Submerged Berms on Slopes," *Transportation Hydraulic Engineering Structures, Transactions of the All-Union Scientific Research Institute of Transportation Constructions*, U.S.S.R., 1967.

WANG, F.C., et al., "Computer Algorithm of Wave Runup on Beaches,"  
*Proceedings of the 14th Coastal Engineering Conference, 1974,*  
pp. 1956-1975.

WASSING, F., "Model Investigation on Wave Runup Carried Out in the  
Netherlands During the Past Twenty Years," *Proceedings of the Sixth  
Conference on Coastal Engineering, Council on Wave Research, 1958,*  
pp. 700-714.



<p>Stoa, Philip N.</p> <p>Reanalysis of wave runup on structures and beaches ; by Philip N. Stoa.--Fort Belvoir, Va. : U.S. Coastal Engineering Research Center ; Springfield, Va.: available from National Technical Information Service, 1978.</p> <p>131 p. : ill. (Technical paper -- U.S. Coastal Engineering Research Center : no. 78-2)</p> <p>Published results of tests of monochromatic wave runup were reanalyzed for both smooth and rough structure surfaces. Wave runup theory is discussed briefly and an empirical equation is given for runup on smooth slopes from waves which break on the structure slope. Example problems and methods of data analysis, together with general observations, are given. Scale effect in runup is also discussed.</p> <p>1. Coastal engineering. 2. Wave run-up. 3. Breakwaters. 4. Revetments. 5. Riprap. 6. Scale effects. I. Title. II. Series: U.S. Coastal Engineering Research Center. Technical paper no. 78-2.</p> <p>TC203 .U581tp no. 78-2 627</p>	<p>Stoa, Philip N.</p> <p>Reanalysis of wave runup on structures and beaches ; by Philip N. Stoa.--Fort Belvoir, Va. : U.S. Coastal Engineering Research Center ; Springfield, Va.: available from National Technical Information Service, 1978.</p> <p>131 p. : ill. (Technical paper -- U.S. Coastal Engineering Research Center : no. 78-2)</p> <p>Published results of tests of monochromatic wave runup were reanalyzed for both smooth and rough structure surfaces. Wave runup theory is discussed briefly and an empirical equation is given for runup on smooth slopes from waves which break on the structure slope. Example problems and methods of data analysis, together with general observations, are given. Scale effect in runup is also discussed.</p> <p>1. Coastal engineering. 2. Wave run-up. 3. Breakwaters. 4. Revetments. 5. Riprap. 6. Scale effects. I. Title. II. Series: U.S. Coastal Engineering Research Center. Technical paper no. 78-2.</p> <p>TC203 .U581tp no. 78-2 627</p>
<p>Stoa, Philip N.</p> <p>Reanalysis of wave runup on structures and beaches ; by Philip N. Stoa.--Fort Belvoir, Va. : U.S. Coastal Engineering Research Center ; Springfield, Va.: available from National Technical Information Service, 1978.</p> <p>131 p. : ill. (Technical paper -- U.S. Coastal Engineering Research Center : no. 78-2)</p> <p>Published results of tests of monochromatic wave runup were reanalyzed for both smooth and rough structure surfaces. Wave runup theory is discussed briefly and an empirical equation is given for runup on smooth slopes from waves which break on the structure slope. Example problems and methods of data analysis, together with general observations, are given. Scale effect in runup is also discussed.</p> <p>1. Coastal engineering. 2. Wave run-up. 3. Breakwaters. 4. Revetments. 5. Riprap. 6. Scale effects. I. Title. II. Series: U.S. Coastal Engineering Research Center. Technical paper no. 78-2.</p> <p>TC203 .U581tp no. 78-2 627</p>	<p>Stoa, Philip N.</p> <p>Reanalysis of wave runup on structures and beaches ; by Philip N. Stoa.--Fort Belvoir, Va. : U.S. Coastal Engineering Research Center ; Springfield, Va.: available from National Technical Information Service, 1978.</p> <p>131 p. : ill. (Technical paper -- U.S. Coastal Engineering Research Center : no. 78-2)</p> <p>Published results of tests of monochromatic wave runup were reanalyzed for both smooth and rough structure surfaces. Wave runup theory is discussed briefly and an empirical equation is given for runup on smooth slopes from waves which break on the structure slope. Example problems and methods of data analysis, together with general observations, are given. Scale effect in runup is also discussed.</p> <p>1. Coastal engineering. 2. Wave run-up. 3. Breakwaters. 4. Revetments. 5. Riprap. 6. Scale effects. I. Title. II. Series: U.S. Coastal Engineering Research Center. Technical paper no. 78-2.</p> <p>TC203 .U581tp no. 78-2 627</p>





<p>Stoa, Philip N.</p> <p>Reanalysis of wave runup on structures and beaches ; by Philip N. Stoa.--Fort Belvoir, Va. : U.S. Coastal Engineering Research Center ; Springfield, Va.: available from National Technical Information Service, 1978.</p> <p>131 p. : ill. (Technical paper -- U.S. Coastal Engineering Research Center : no. 78-2)</p> <p>Published results of tests of monochromatic wave runup were reanalyzed for both smooth and rough structure surfaces. Wave runup theory is discussed briefly and an empirical equation is given for runup on smooth slopes from waves which break on the structure slope. Example problems and methods of data analysis, together with general observations, are given. Scale effect in runup is also discussed.</p> <p>1. Coastal engineering. 2. Wave run-up. 3. Breakwaters. 4. Revetments. 5. Riprap. 6. Scale effects. I. Title. II. Series: U.S. Coastal Engineering Research Center. Technical paper no. 78-2.</p> <p>TC203 .U581tp no. 78-2 627</p>	<p>Stoa, Philip N.</p> <p>Reanalysis of wave runup on structures and beaches ; by Philip N. Stoa.--Fort Belvoir, Va. : U.S. Coastal Engineering Research Center ; Springfield, Va.: available from National Technical Information Service, 1978.</p> <p>131 p. : ill. (Technical paper -- U.S. Coastal Engineering Research Center : no. 78-2)</p> <p>Published results of tests of monochromatic wave runup were reanalyzed for both smooth and rough structure surfaces. Wave runup theory is discussed briefly and an empirical equation is given for runup on smooth slopes from waves which break on the structure slope. Example problems and methods of data analysis, together with general observations, are given. Scale effect in runup is also discussed.</p> <p>1. Coastal engineering. 2. Wave run-up. 3. Breakwaters. 4. Revetments. 5. Riprap. 6. Scale effects. I. Title. II. Series: U.S. Coastal Engineering Research Center. Technical paper no. 78-2.</p> <p>TC203 .U581tp no. 78-2 627</p>
<p>Stoa, Philip N.</p> <p>Reanalysis of wave runup on structures and beaches ; by Philip N. Stoa.--Fort Belvoir, Va. : U.S. Coastal Engineering Research Center ; Springfield, Va.: available from National Technical Information Service, 1978.</p> <p>131 p. : ill. (Technical paper -- U.S. Coastal Engineering Research Center : no. 78-2)</p> <p>Published results of tests of monochromatic wave runup were reanalyzed for both smooth and rough structure surfaces. Wave runup theory is discussed briefly and an empirical equation is given for runup on smooth slopes from waves which break on the structure slope. Example problems and methods of data analysis, together with general observations, are given. Scale effect in runup is also discussed.</p> <p>1. Coastal engineering. 2. Wave run-up. 3. Breakwaters. 4. Revetments. 5. Riprap. 6. Scale effects. I. Title. II. Series: U.S. Coastal Engineering Research Center. Technical paper no. 78-2.</p> <p>TC203 .U581tp no. 78-2 627</p>	<p>Stoa, Philip N.</p> <p>Reanalysis of wave runup on structures and beaches ; by Philip N. Stoa.--Fort Belvoir, Va. : U.S. Coastal Engineering Research Center ; Springfield, Va.: available from National Technical Information Service, 1978.</p> <p>131 p. : ill. (Technical paper -- U.S. Coastal Engineering Research Center : no. 78-2)</p> <p>Published results of tests of monochromatic wave runup were reanalyzed for both smooth and rough structure surfaces. Wave runup theory is discussed briefly and an empirical equation is given for runup on smooth slopes from waves which break on the structure slope. Example problems and methods of data analysis, together with general observations, are given. Scale effect in runup is also discussed.</p> <p>1. Coastal engineering. 2. Wave run-up. 3. Breakwaters. 4. Revetments. 5. Riprap. 6. Scale effects. I. Title. II. Series: U.S. Coastal Engineering Research Center. Technical paper no. 78-2.</p> <p>TC203 .U581tp no. 78-2 627</p>





