



MARINE BIOLOGICAL LABORATORY.

Received August 1, 1936

Accession No.

Given by P. Blakiston's Son & Co.
Place, Philadelphia

**No book or pamphlet is to be removed from the Laboratory without the permission of the Trustees.

MBL/WHOI



0 0301 0010297 6

RECENT ADVANCES IN MICROSCOPY

THE RECENT ADVANCES SERIES

RADIOLOGY

By PETER KERLEY, M.B., B.Ch.

PSYCHONEUROSES

By MILLAIS CULPIN, M.D., F.R.C.S.

DISEASES OF CHILDREN

By W. J. PEARSON, D.S.O., D.M., F.R.C.P., and W. G. WYLLIE, M.D. Second Edition.

SURGERY

By W. H. OGILVIE, M.D., F.R.C.S. Second Edition.

MEDICINE

By G. E. BEAUMONT, D.M., F.R.C.P., D.P.H., and E. C. DODDS, M.V.O., M.D., B.S., Ph.D. Sixth Edition.

OBSTETRICS AND GYNÆCOLOGY

By ALECK W. BOURNE, F.R.C.S. Second Edition.

PHYSIOLOGY

By C. LOVATT EVANS, D.Sc., F.R.C.P., F.R.S. Fourth Edition.

BIOCHEMISTRY

By J. PRYDE, B.Sc., M.Sc. Third Edition.

HÆMATOLOGY

By A. PINEY, M.D. Third Edition.

OPHTHALMOLOGY

By W. STEWART DUKE-ELDER, M.D., F.R.C.S. Second Edition.

ANATOMY

By H. WOOLLARD, M.D.

TROPICAL MEDICINE

By SIR LEONARD ROGERS, C.I.E., F.R.S., M.D., F.R.C.P., F.R.C.S. Second Edition.

BACTERIOLOGY

By J. HENRY DIBLE, M.B., Ch.B.

NEUROLOGY

By W. RUSSELL BRAIN, D.M., and E. B. STRAUSS, B.M., B.Ch. Second Edition.

PSYCHIATRY

By H. DEVINE, O.B.E., M.D., F.R.C.P.

CARDIOLOGY

By TERENCE EAST, M.D., F.R.C.P., and C. W. C. BAIN, M.B. Second Edition.

PULMONARY TUBERCULOSIS

By L. S. T. BURRELL, M.A., M.D., F.R.C.P. Second Edition.

PREVENTIVE MEDICINE

By J. F. C. HASLAM, M.C., M.D.

CHEMOTHERAPY

By G. M. FINDLAY, O.B.E., M.D., D.Sc.

RHEUMATISM

By F. J. POYNTON, M.D., F.R.C.P., and BERNARD SCHLESINGER, M.D., M.R.C.P.

PLANT PHYSIOLOGY

By E. C. BARTON-WRIGHT, M.Sc.

ENTOMOLOGY

By A. D. IMMS, D.Sc., F.R.S.

FORENSIC MEDICINE

By SYDNEY SMITH, M.D., and JOHN GLAISTER, Jnr., M.D.

RECENT ADVANCES IN MICROSCOPY

BIOLOGICAL APPLICATIONS

EDITED BY

A. PINEY

M.D., M.R.C.P.

*Director of the Pathological Department,
Cancer Hospital, London*

MEDICINE By A. PINEY, M.D., M.R.C.P.

THE LIVING EYE

By BASIL GRAVES, M.C., M.A., M.R.C.S.,
D.O.M.S.(Eng.).

ZOOLOGY By E. W. MACBRIDE, LL.D., D.Sc., F.R.S.,
and

H. R. HEWER, A.R.C.S., D.I.C., M.Sc.

BOTANY By E. C. BARTON-WRIGHT, M.Sc.

WITH 83 ILLUSTRATIONS

PHILADELPHIA

P. BLAKISTON'S SON & CO. INC.

1012 WALNUT STREET

1931

Printed in Great Britain

PREFACE

IT is difficult to present a book on Recent Advances in Microscopy as a coherent whole, and if it were done it would, undoubtedly, have an air of being forced. In this book each writer has been given a free hand in the presentation of his subject ; as a result, the articles show considerable variation of style, depending to a great extent on the view taken by the writer as to the amount of knowledge likely to be possessed by the reader. In so small a book it is, of course, impossible to present a complete picture of the present state of microscopical science, but enough has been written to make it clear that progress is rapid in this essential branch of biological investigation ; and there is no doubt that the results being obtained are of a kind likely to be of permanent and increasing value.

It has been difficult to determine how much to discuss, but so far as possible none of the material found in other volumes of this series has been included ; thus, other information will be obtained from Recent Advances in Anatomy, in Physiology and in Hæmatology ; these books can, therefore, be used to supplement the present volume.

A. PINEY

LONDON

CONTENTS

| SECTION | PAGE |
|---|----------------|
| PREFACE | V |
| I. THE MEDICAL SCIENCES | 1-30 |
| Introduction | 1 |
| Cell-Organs | 3 |
| Tissues and Organs | 6-30 |
| Skin—Stomach—Intestine—Liver—Pancreas—Blood —Lymphocytes—Myeloblasts—Granular Leucocytes —Blood Platelets—Macrophages—Pituitary—Thyroid Parathyroids—Thymus—Adrenals—Muscle. | |
| II. MICROSCOPY OF THE LIVING EYE | 31-87 |
| III. ZOOLOGY | 88-167 |
| Introductory—The Structure of the Golgi Apparatus— The Function of Golgi Apparatus—Morphology and Function of the Mitochondria—The Nucleus and Nucleolus —Spermatogenesis, Oogenesis and Yolk Formation— Miscellaneous—Protozoa—Cell Membranes—Pathological Cytology. | |
| IV. BOTANY | 168-254 |
| The Golgi Apparatus—Mitochondria—The Vacuome—The Structure of Chromosomes—The Nucleolus—Nuclear Division—Plasmodiophorales—Cyanophyceæ—Bacteria— Achromatic Figure—Cytokinesis—Meiosis—Brachymeiosis —Sex-Chromosomes—Polyploidy—Haploids—Aneuploids —Higher Polyploids—Polyploidy in the Graminæ—Poly- ploidy as a Source of Species and Horticultural Varieties— Sterility and Polyploidy in Cultivated Fruits—Micro- dissection—Cytoplasm—Chloroplast—Nucleus— Chromosomes—Meiosis—The Microscopy of the Cell Wall —The Cotton Hair—The Structure and Formation of Lignified Tissues. | |





RECENT ADVANCES IN MICROSCOPY

Section I

THE MEDICAL SCIENCES

By A. PINEY, M.D., M.R.C.P.

Director of the Pathological Department, Cancer Hospital,
London.

INTRODUCTION

THE use of the microscope is so essential a method in medical practice and research that recent advances consist mainly in improvements in technique and in new observations of fine structure. The details of technical methods will not be recorded here ; in fact, this chapter is intended rather to give an account of the present position of medical microscopy, that is, mainly of microscopical anatomy, than to give a bald list of disconnected observations, however interesting these might be to the professional histologist. That there are very definite limitations to the advances possible to microscopy must of course be admitted, but this in no way impairs the value of this method of approach to biological truth. First, it must be made clear that histological methods can never do more than give us a picture equivalent to some living structure ; we must not expect to gain a view of living structures at work. It may be objected that such methods as supra-vital staining, as used by Sabin, supply a closer insight into living structure than these words would imply. In a sense

this is true, but the number of structures displayed by this method is very limited, and even those made visible are not shown in great detail. Furthermore, such methods present to our senses only structures as they exist in the presence of some more or less non-toxic dyestuff : not as they are in their natural environment. After saying so much as to the deficiencies of microscopy, we can approach the subject of the present volume in a humble spirit, admiring the persistence that has given such admirable results.

No attempt has been made to convert this chapter into a work of reference : nothing more has been tried than to give an impression of the present position of certain aspects of human histology in their present state of development. For this reason persons are scarcely mentioned, because, as the book is not intended for the professional histologist, coherence of the account appeared to be more important than completeness of the documentation.



CELL-ORGANS

MITOCHONDRIA are minute intra-cellular structures having certain distinctive characters, viz. :—

They are of low refractive index, and give a characteristic reaction with the dyestuff termed Janus Green, even in a solution as dilute as 1 in 500,000. Further, they are composed of a substance that is very soluble in alcohol, acetic acid, and many other fixatives.

As their name implies, they are often of thread-like appearance, but other shapes are well recognised, although no animal has mitochondria of a form peculiar to itself. It is, however, very striking that similarity of function seems to be associated with similarity in the shape of the mitochondria. There is no very obvious orderly arrangement of these structures in most cells, although in the kidney they are collected in the basal parts of the cells, *i.e.*, next to the blood vessels. Indeed in all other glands which always secrete in the same direction, the mitochondria are arranged at the end of the cell furthest from the glandular lumen. In the intestine the conditions are peculiar because mitochondria are piled up at both ends of the cells, presumably as an indication of the dual function of secretion and absorption.

In 1898 Golgi described certain cytoplasmic components in nerve cells. These structures, now usually known as the Golgi apparatus, present a peculiar contorted or basket-like arrangement. At about the same time as Golgi's publication, Holmgren had discovered and described certain clear canals in animal cytoplasm. These, in form, arrangement and position, so much resembled the Golgi apparatus, that the two structures were often regarded as being one ; a view no longer held.

The Golgi apparatus is an area of cytoplasm, often of reticular form, and of variable size, sometimes being as large as a nucleus. The material of which the structure is composed is in part soluble in

alcohol ; this moiety can be stained with osmic acid. Most of the methods for the demonstration of the Golgi apparatus are based on the observation that, after suitable modes of fixation, a great affinity for silver is developed.

Usually the Golgi apparatus is a fairly dense network of anastomosing strands. Even in adjacent cells its shape is different, presumably as an indication of great functional plasticity. In spite of such differences, it can be said with certainty that in a general way the form of the Golgi apparatus is fairly typical of the special cell type. Any variations of structure seem to be related to functional peculiarities in the cells in question ; thus there is a generic similarity in the Golgi apparatus of the pancreas of different animals, and the same applies to its appearances in many other organs.

The great majority of animal cells contain a Golgi apparatus, although of very varying degrees of complexity ; in some formed elements, for example red corpuscles, no trace of the network can be found. Indeed there seems to be some evidence that the apparatus is found only in cells engaged in or capable of active functional manifestations. It is presumably for this reason that the cells of developing embryos supply the most admirable material for the study of the Golgi apparatus in its most typical forms.

More details of the appearances of the structure in special organs will be found later, but some general remarks are not out of place at this stage. There seems to be some relationship between the position of the Golgi apparatus and the functional characters of the cell in which it lies, although alteration in the position of the cell, and therefore presumably of the mode of activity, is not always accompanied by a redistribution of the Golgi apparatus ; thus, in ectodermal cells, these structures lie between the nucleus and the periphery of the cell body ; and even when the tissue is reversed, as during the formation of the optic cup, this relationship persists. In cells which always secrete in the same direction as, for example, those of the pancreas, the apparatus lies between the nucleus and the glandular lumen ; but in the thyroid, at least in the guinea-pig, it appears that the structure can migrate from one

end of the cell to the other. It may be too bold, although fascinating, to assume that this reversal is associated with redirection of the secretion. Furthermore there is often a topographical relationship between the Golgi system and the centrosome; certainly this is so in the thyroid. Here the centrosome usually lies with the Golgi apparatus between the nucleus and the lumen, but in some malignant tumours of this organ both structures lie between the nucleus and the vascular network. It is striking that, when this reversal of position has occurred in practically all the cells, the acini are devoid of colloid contents. Again the suggestion seems to be that secretion has occurred towards the Golgi system, that is away from the glandular lumen, into the bloodstream.

There is still much uncertainty as to the relationship of the Golgi system to the system of canals (trophospongium) described by Holmgren. In many nerve cells there is no doubt that the two structures are totally distinct.

This brief introduction to the subject of cell-organs can well be followed by a detailed description giving an account of recent advances in histology, for that is indeed what our subject might well have been termed.

TISSUES AND ORGANS

SKIN

THE protective function of the integument is the most obvious function of the covering of the body. As is well known there are a number of layers forming the skin, and these become more and more impervious as one travels from the deeper to the more superficial strata. The most obvious histological sign of this differentiation is the presence of keratinization, but there are other, more subtle changes, throughout the layers. As one passes from within outwards there is found a decrease of mitochondria and Golgi system, both being lost in the most superficial cells. Whilst keratohyalin and keratin increase, melanin becomes scantier, and the cells change in shape, whilst fibrillæ and inter-cellular bridges are formed. It appears that the whole series of changes gives rise to the appearance of an almost impervious covering for the body.

The intra-cellular fibrils of human skin are relatively easily rendered visible and are therefore very suitable subjects for studying the vexed question of the nature of these structures. It is quite commonly held that the mitochondria give rise to these fibrils by rearrangement of their positions; further, their breakdown is supposed to result in the formation of keratohyalin. If such be the case, it is easily understood why mitochondria are absent from the most superficial layers of the integument. The inter-cellular bridges, which obviously serve the purpose of holding the cells together, may also act as carriers of stimuli from one element to another. It is stated that the small thickening found in the middle of each bridge is a mitochondrial development, but a clear demonstration of this belief would be difficult.

There has been, and still is, much discussion as to the mode of origin of cutaneous pigment, *i.e.*, melanin, and here only the available facts will be recorded. In the most basal cells there is

formation of this pigment. These elements of course lie near the blood vessels and have ample mitochondria and Golgi apparatus. In them the melanin arises almost certainly from a colourless precursor, leuco-melanin. The coloured granules lie between the nucleus and the surface of the body ; perhaps Ludford's suggestion that this is a mode of protecting the nucleus from the injurious effects of strong ultra-violet light is an explanation of the arrangement. So far we are on fairly safe ground ; the controversy starts in connection with a second mode of formation of pigment in certain elements of irregular shape : the melanoblasts. These lie only in the stratum germinativum and their processes extend between the neighbouring epithelial cells. The word elements has been used here instead of the more usual term cells, because it is quite possible that we are really dealing simply with inter-cellular spaces rendered visible by being filled with granules of pigment.

The process of keratinization has not been adequately explained, and even a statement of the sequence of events leading to the production of keratin is inevitably incomplete. The change occurs as the cells migrate further and further away from their blood supply and presumably become more dependent upon slow methods of nutrition, viz., by diffusion through the inter-cellular spaces. Keratinization might therefore be the result of malnutrition or of the difficulty of complete removal of waste substances from the cell body. The latter view is supported by Drew's observation that keratinization will occur in tissue cultures of skin if subcultures are not made at sufficiently short intervals. Further, he showed that the process of formation of the horny substance proceeded most actively and efficiently in the presence of connective tissue. Obviously the cells of the skin, when becoming keratinised, are far removed from any influence likely to be exerted by mesoblastic tissue.

STOMACH

Perhaps one of the most important regions to which much investigation has been devoted is the lining of the stomach. Obviously the human stomach is but rarely in a suitable state for

fine histological observations. In post-mortem material the time that elapses between the time of death and of examination is sufficient to cause grave changes in the cells. With operation material normal tissue is not usually available, but certainly this has proved more suitable than have stomachs removed at autopsy.

The mitochondria of the gastric mucosal cells are long filaments that extend from the attached end of the cell ; or perhaps Eklöf's statement is more correct, when he states that these elongated mitochondria really consist of granular fragments arranged in rows.

It is commonly recognised that the gastric glands contain two types of cells, viz., peripheral and central ; usually termed parietal and chief cells respectively. A third type of cell is found adhering to the external surface of the epithelial tubes. The chief cells are of two types ; those in the neck of the gland are mucus-secreting elements, whereas those in the body of the gland are of zymogenous character. It is interesting to note that the chief cells of the neck, the cells of the pyloric glands and those of the cardiac glands of the stomach all belong to the same type.

The chief cells of the body of the glands are essentially zymogenous in function, and there is a distinct impression that the formation of the zymogen granules is closely associated with the mitochondria. The chief cells of the neck also contain secretion granules, but, unlike those in the body chief cells, these are almost completely translucent. Suitable methods demonstrate the presence of mucin in these elements. Cells of this type are not rigidly confined to the necks of the glands : they are often seen scattered throughout the body of the gland. Indeed, in man, whole glands, particularly in the region of the fundus of the stomach, may be composed of neck cells.

The parietal cells have been recognised for a much longer time than have the chief cells ; indeed the former were for long regarded as being the only cellular constituents of the glands. They are most numerous in the neck of the gland, but also occur under the foveolar epithelium. These cells are connected with the lumen of the gland by channels passing between the contiguous surfaces of the chief cells. Furthermore each one contains a

complex system of intra-cellular channels, which lie between the nucleus and the convex edge of the cell. This communicates with the lumen by way of one or more of the inter-cellular channels already mentioned. When the stomach is actively secreting it is found that the staining reaction to neutral red is the same in the lumen as in the parietal cells; there is thus clearly an important contribution to the gastric secretion derived from these elements.

The Golgi system of the parietal cells differs in the elements lying in the upper portion of the gland when compared with the deeper cells. In the former there is a coarse perinuclear network, whereas in the latter the reticulum is finer and lies around the periphery of the cell. In neither case is there any obvious relationship between the Golgi apparatus and the mesh of secretory channels; nor is there any particular polar arrangement of the apparatus such as has been mentioned in the case of other secretory cells.

The third type of cell is very variable in its distribution, being absent from the stomachs of some animals; the rabbit is a particularly suitable subject for investigation of the structure. These elements lie on the surface of the glands and stain deep yellow with bichromate solutions. It is surprising how often these cells have been "rediscovered" since they were first described by Heidenhain in 1870; thus as recently as 1924 Twort referred to them as an "Hitherto undescribed Type of Cells in the Glands of the Stomach."

It is important to refer to the frequent occurrence of patches of intestinal glands inside the stomach, not only in pyloric region, but also nearer to the fundus. Such masses are identical with the lining of the small intestine. The most interesting feature of this heterotopia is that it has never been recorded in autopsies on the new-born or on very young children. When it has been seen in adults there has always been found some associated pathological condition of the stomach. It would appear, therefore, that the hypoblast of the foetal foregut possesses the power to develop epithelial cells of the intestinal type; even more surprising is the fact that this power does not appear to be lost by the apparently highly differentiated epithelium of the adult stomach.

INTESTINE

The cytoplasm of the columnar absorbing cells is filled with large numbers of very minute granules. The nucleus lies rather below the middle of the cell, and the area above it may be clear, but still above the nucleus. Below there is a more alveolar arrangement of the cytoplasm in which lie the mitochondria and a double centrosome. Still deeper the Golgi apparatus lies just above the nucleus and is in the form of a wide coil. The infra-nuclear area is closely packed with mitochondria. In the cells of the villi these structures are collected into two masses, one at each end of the cell. Their number appears to give some indication as to the functional state of the cell at the time of examination. Thus they are far more numerous in starvation, whereas they become scanty and less thread-like after feeding. The tension-fibres that Heidenhain described as running through these cells are now usually considered to be mitochondria.

In connection with the so-called carcinoid tumours of the appendix there has been a renewal of interest in the basal or argentaffin cells of the intestine. These are usually scattered about amongst the other intestinal elements. They may be found in the stomach, villi, crypts, and in Brunner's glands; even in the pancreatic duct a few may be discovered. Although so widely scattered and apparently small in number they have the general appearances of a secretory apparatus. They are most numerous in the crypts where many of them are flask-shaped, usually with the narrower end at the base. When the base is the widest part the distal end may taper almost to the thickness of a fibril, which may or may not reach the lumen; Masson contends that the cells should be classified according to the distance to which these fibrils extend. The granules in the cells show a great affinity for chromium salts. Kull proposed to term them "chromaffin cells," but this name is objectionable because of the certainty of confusion with the quite unrelated cells of the sympathetic nervous system. As the granules also stain well with silver the name argentaffin cells proposed by Masson should be adopted. The constituents of the cell that stain with silver are mainly the numerous small granules, which, unlike those of the

Paneth cells, are almost all subnuclear in position. There has been much confusion about these cells, but we are now in a position to clarify the position a good deal. Kultschitzky described certain elements in which the subnuclear cytoplasm was filled with acidophilic granules ; and these cells were regarded as being different from the argentaffin cells in which the granules are intensely safraninophilic. Kull, however, has shown that the former type of cell is only a less mature aspect of the typical argentaffin cell.

The function of these cells is unknown, but the common view that they contribute to the intestinal contents in some uncertain way is difficult to reconcile with an interesting observation made by Kull. This writer showed that the protoplasm of these cells projects into the lumina of adjacent capillaries. This has led some to postulate an endocrine function for these elements ; thus Parat believes that they pour secretin into the blood. Masson, on the other hand, avers that they bathe the nerve-endings with some unknown secretion. As yet no one has been able to demonstrate any changes in these cells during the assimilation or digestion of any particular foodstuff.

LIVER

As might be expected from the known diversity of function of the liver, there is great cellular complexity in its constituent elements ; and here only a few recent observations need be discussed because the general histology of the organ is sufficiently well known.

The essential character of the cytoplasm of the liver cell is a reticulation, in the interstices of which complex chemical substances are found, *e.g.*, glycogen, fatty substances, etc. It appears, therefore, from the histological evidence, that the various activities of the liver, although functions of one organ, are carried out in specialised areas of the constituent cells. This is perhaps to be regarded as encouraging, for, were it not so, any investigation of a single function of the organ would be impossible without taking into account all the other activities.

The stellate cells of Kupffer will be discussed in relation to the

reticulo-endothelium in general, because, although in the liver, they are *sensu stricto* not of it.

PANCREAS

There is nothing new to report as to the microscopic characters of the pancreas proper, but the islets of Langerhans present points of interest, especially in connection with the relatively recent discovery of insulin.

All the cells of the islets contain granules, which at first sight do not differ from those of the externally secreting cells. Closer investigation shows that there are two types of granules in the islets. A-granules are precipitated by alcohol and lie in cells with large spherical nuclei containing little chromatin. Cells containing these granules lie in the middle of the islets, and may be diffusely filled with granules or almost all these may be aggregated on the side of the cell nearest to the capillary. B-granules are precipitated by watery solution of chromic acid and sublimate. They are much smaller than the A-granules, and cells containing them are much more numerous than are the A-cells. The nucleus, which is central, is small and densely chromatic. Lastly there are some cells with no granules; but there are some with a very small number of A-granules. It is therefore supposed that the A-cells can arise from these non-granular elements. The old view that islet cells could be converted into acinar cells has been disproved by Bensley, who has shown clearly that the former are specifically differentiated elements incapable of differentiation into any other form.

Even the mitochondria show distinct differences between the acinar and islet cells. In the former they are long relatively coarse filaments, whereas in the latter they occur as very delicate filaments and as very fine granules.

In spite of the specific characters of the islet cells it must be recalled that the human embryo of about three months shows the islets connected with lumina by solid stalks; in still-born infants such a connection is sometimes persistent.

In diabetes various changes have been described in the islets, but even so some severe cases seem to have shown no pathological

changes in the cells of these structures. Certainly the hydropic degeneration which is so frequently the essential lesion is not easy to detect and is often masked by post-mortem changes. It has indeed been suggested that this degeneration might result from hyperglycæmia, and not be its cause. Allen has shown that the change cannot be induced by causing prolonged hyperglycæmia of alimentary origin in dogs.

BLOOD

This is not the place to follow out the ramifications of the trains of thought of hæmatologists as to the origin of all blood cells from one or more ancestral forms because there is still no sign of unanimity; the many text-books of hæmatology can be consulted by those interested in this rather barren subject.

Lymphocytes. It is interesting that the first description of mitochondria in lymphocytes was regarded as a very striking hæmatological discovery because it was not realised that these structures were identical with the similar ones observed in many other varieties of cells. Schridde thought that the granules were specific characters of lymphocytes; so that he claimed to have demonstrated a differential feature as between lymphocytes and myeloblasts. It was presumably only the highly specialised character of hæmatology that had prevented him from correlating his findings with those of other microscopists: indeed, a valuable demonstration of the folly of excessive specialization!

In connection with lymphocytes it were well to mention plasma cells, because there is still some confusion as to the position of these common elements. The essential characters of these cells are: a relatively small nucleus in an excentric position; the chromatin often presents an arrangement resembling a cart-wheel; the fixed protoplasm has a granulated appearance and stains very intensely with basic dyestuffs, but the part around the nucleus is much paler. Furthermore there is a pallid area in the central part of the cell in which suitable staining demonstrates the presence of a number of centrioles. This is the typical plasma cell which is now almost universally believed to arise from small and medium-sized lymphocytes. The terminological confusion that exists is

due to the application of the name to other elements that possess some similar characters.

It is quite common to find, in the blood, even of normal humans, a small number of cells with intensely basophilic cytoplasm in which the nucleus is not excentric. These are the so-called irritation cells of Türk, and seem to be stages in the development of the true plasma cell, so that there is perhaps no very great objection to classifying both forms together. Difficulties arise, however, in some cases of leukæmia in which cells with intensely basophilic cytoplasm are present in the peripheral blood. These elements usually present signs of very definite immaturity, *e.g.*, nucleoli are distinctly visible. Those who regard lymphocytes as being derived from a specific stem-cell, the lymphoblast, contend that some of these elements may justifiably be called lymphoblastic plasma cells. It is also well known that almost any cell with non-granular cytoplasm may, in abnormal circumstances, show excessive basophilia of its body ; so we read of myeloblastic, monocytic and even erythroblastic plasma cells. In view of the uncertainty of the whole nomenclature it is indubitably best to describe these cells in detail, or, if a name must be used, to state definitely to which category one wishes to refer them ; the simple name " plasma cell " is far too ambiguous to be employed without due qualification.

The function of the lymphocytic plasma cell is unknown, but histological examination of carcinomata suggests that they may play a part in absorbing and disposing of products of tissue metabolism ; certainly they are often very numerous in the stroma of epithelial malignant tumours where presumably intense katabolic processes are present.

Myeloblasts. It has already been said that the vexed question of the origin of blood cells will not be considered here in any detail, but some reference must be made to the non-granular leucocyte with an immature form of nucleus so often seen in the blood in acute leukæmias. It must be presumed that the reader is acquainted with the usual descriptions of these cells, so that we can pass directly to an account of their characters as determined by the method of supra-vital staining with neutral red and Janus

green. In the marrow it is possible to find reticular cells in the cytoplasm of which a few dark bodies are present ; these are certainly not typical mitochondria, although they may well be precursors of such structures. It is to the method of depleting the bone marrow of pigeons by starvation that we owe the discovery of this cell-type. The next more mature cell discoverable contains definite rod-shaped mitochondria that stain with Janus green, the subsequent stage being an element in which the mitochondria are in the form of quite short rods, present in considerable numbers. Up to this developmental condition there are no structures staining with neutral red, and it is highly probable that these three types of cell are not distinguishable from one another by the ordinary methods of staining used in clinical hæmatology : all these forms would be termed myeloblasts by the polyphyletists, whereas the monophyletists would term them lymphoidocytes. The next phase of maturation is the appearance of two or three small granules staining with neutral cell : this is the so-called myelocyte, type A, which must correspond with the premyelocyte of clinical hæmatology. There is gradual increase of neutral red granules as the cells become more mature, and the mitochondria get fewer and fewer, until in myelocyte, type C, they are almost completely replaced by neutral red granules. At this stage the nucleus has become indented, and we are dealing with the metamyelocyte of ordinary terminology ; that is, an almost mature granulocyte is characterised by practically complete absence of mitochondrial structures staining with Janus green.

Granular Leucocytes. Only two aspects of the extensive subject of the granular leucocytes need be discussed. First, the teaching of Arneith which is not recent, although its ramifications are of very modern date. Briefly, Arneith contends that the greater the degree of complexity of the nucleus of a granular leucocyte, the greater is its stage of maturity. It is obvious that a myelocyte with a completely round nucleus is younger than a metamyelocyte with a slightly indented one, but it is not quite so certain that a polymorphonuclear cell with two lobes in the nucleus is necessarily younger than is one with three or more lobes. Nevertheless most workers who have spent much time on this

subject agree more or less with Arneth's deductions, although they may differ from him in their definition of the essential characters of a nuclear lobe. In this matter it were well to follow Cooke, who contends that no nuclear part should be called a lobe unless it be connected by nothing more than a single basi-chromatic fibril. If this method be used as a routine many diagnostic and prognostic deductions of great clinical value can be drawn from microscopical examination of blood films, so that the method should not be neglected, even if the theoretical inferences of Arneth are disputed. It is not necessary to do more than indicate that Arneth has complicated his method still further by subdividing the various groups according to the shape of the individual nuclear lobes, but this laborious technique has not found much support from clinical hæmatologists, perhaps because of its difficulty. Certainly there is no extensive evidence of its value other than the work of its discoverer, which is very profound and has extended over very many years.

Blood Platelets. There is probably no formed element of the blood about which so much ink has been spilt, but the modern position can be defined quite briefly. The usually accepted contention is that blood platelets are derived from the megakaryocytes of the blood marrow. These are large elements of irregular shape in which there lies a large and contorted nucleus. The most interesting feature of these elements is the granularity of the cytoplasm. The granules are minute intensely azurophilic structures which do not lie evenly distributed in the cytoplasm, but are collected into small discrete groups. Wright contended, and most microscopists agree with him, that these fields of granules with the surrounding portion of cytoplasm are projected as pseudopodia through the lining of the blood vessels of the marrow, then being broken off in the blood stream where they are blood platelets. Wright's original pictures were indeed very suggestive, but more recent observations of the occurrence of abnormal blood platelets has strengthened the evidence very much. In cases of hæmorrhagic purpura it is common to find gigantic forms of platelets in the peripheral blood; these are not usually simply larger forms of the ordinary element, but show quite different

appearances. They do not consist simply of a mass of faintly basophilic cytoplasm in the middle of which lies a collection of azurophilic granules, which is the character of the normal platelet. They are apparently composed of several such platelets connected together; in other words, their microscopical characters strongly suggest that they are in reality small pieces of the cytoplasm of the megakaryocyte broken off *en masse* instead of in smaller fragments. The impression obtained is as of deficient differentiation of the megakaryocytic cytoplasm prior to the protrusion of the pseudopodium, so that separation has occurred too soon. Certainly these giant platelets differ in no respect other than size from the cytoplasm of the giant cells of the bone marrow. There is, however, yet further evidence of the accuracy of Wright's interpretation of his microscopical preparations. In some cases of myeloid leukæmia there are found parts of nuclei in the peripheral blood. These pieces have the characters of the nuclei of megakaryocytes, but of course are much smaller. Attached to the nuclear fragment are always seen a number of irregular structures having all the characters of blood platelets. Lastly, histological examination of the lungs often reveals the presence of whole megakaryocytes lying, as emboli, in the pulmonary capillaries; here the cytoplasm still shows the arrangement and tinctorial characters of blood platelets. It seems, therefore, quite justifiable to regard the blood platelet as being one of the few structures of which the developmental history is accurately known, although the same cannot be said of the origin of the megakaryocyte itself. It is commonly supposed that these large cells, which may be as much as forty microns in diameter, are derived from the reticulo-endothelium by simple increase in size, but this is far from being certain. It is also known that the cell, when young, is actively phagocytic; a power that is lost by the older forms. *Pari passu* with this alteration of functional ability there proceed certain histological changes. Thus the young forms contain many mitochondria of thread-like appearance, whilst a skein of Golgi apparatus lies near the centrosomes; in older forms mitochondria are less numerous, and the Golgi system can usually not be seen.

Macrophages. These peculiar elements have been the subject of most intensive study during recent years; here the account given by Maximow will be followed fairly closely, because no other worker has made such outstanding contributions to this complex subject. It is not possible to define the subject of this section more nearly than by saying that these elements form a widely scattered system that plays an important rôle in many defence mechanisms, particularly in inflammatory processes. It is now realised that the so-called resting wandering cells of the body really belong to one great, although scattered, cell-group, which can be demonstrated by the method of intra-vitam staining with a variety of more or less non-toxic colloidal substances. The series of cells so made obvious is often known as the *reticulo-endothelium*, although there are objections to the name because the ordinary endothelium of blood vessels is a structure entirely different from the histiocytes and the reticular cells. The name "histiocyte" is in common use, although its significance is no longer accepted in its original form. It was supposed that these tissue cells were totally and entirely distinct from the leucocytes of the blood, but it is now commonly admitted that their histories are closely intertwined. The modern convention is to term histiocytes those cells stainable with certain colloidal dyestuffs injected into the blood stream, but of course, in human pathology and physiology, this test is but rarely possible. There are therefore many cells allocated to the histiocytic or reticulo-endothelial system simply because they occupy the position or have the appearance of elements known to be vitally stainable in other animals. The interest in these cells, which lie so close to or, indeed, are part of the supporting reticulum of the tissues, has stimulated research into this reticular stroma itself, and, as a result method, technical methods of great value have emerged. These procedures are almost all based upon the neuro-histological methods introduced by the Spanish school of Cajal, that is, they are dependent upon impregnation with silver. Well-made preparations show many surprising features, and supply some good reason for the use of the name *reticulo-endothelium* so long as it is realised that the lining of ordinary blood vessels is not included

in the conception. In lymphatic glands the sinuses are lined by elongated cells usually known as endothelium in spite of many structural differences between its cells and those of vascular endothelium. In this section there will be no discussion of the lining cells of ordinary blood vessels, and therefore the term "endothelial cell" will be applied without further apology to elements of the type that line lymphatic sinuses in lymphatic glands. The boundary of such sinuses has long been recognised as not being composed of a complete and continuous layer of cells, but there are nevertheless no distinct gaps in the continuity of the walls. The completeness of the boundary has been supposed to result from the inter-digitation of the elongated processes of the endothelial cells, but to-day this is not regarded as being correct, because two types of cell can be found in the wall. First there is the endothelial cell, which does not seem to have any very obvious processes, and secondly, there is the so-called reticular cell which has only a small cell body and extensive branching processes. In many pathological conditions the lining of the lymphatic sinuses differs very much from normal. For example, in Hodgkin's disease, when seen in an early stage, there are surprisingly few reticular cells, whereas endothelial elements are very greatly increased in number. Later, in the stage of so-called fibrosis, the appearances are very different. Lymphocytes and endothelial cells are very scanty, whereas fine fibrils are numerous and almost completely fill the tissue. Giant cells which were fairly numerous in the earlier cellular stage are now difficult to find, so that there is an impression as of a diffuse fine fibrosis. The two histogenetic possibilities that immediately present themselves are either that a new cell type has ousted the endothelial elements or that there has been conversion, that is, metaplasia, of the earlier type of elements into the final variety of tissue. There is no evidence that the former process is possible, whereas the evidence for the latter is quite sound. Suitably stained and impregnated sections of the tissues in the earlier stages of the disease show peculiarly intimate relations between the endothelial cells and the fairly scanty argentaffin fibrils, inasmuch as the former are obviously surrounded by a close network of fine fibrils. It is only on very

careful examination, preferably of serial sections, that it is possible to determine an even closer relationship. It can be seen that many of the endothelial cells contain in their cytoplasm extremely tenuous argentaffin fibrils, which, in single sections, usually appear to be nothing more than disconnected fragments. In serial sections it is possible to see that the fragments are not simply an inchoate collection of bits of argentaffin material; they are indeed fibrils, which seem to emerge from the cells to ramify in the adjacent tissue. It is not clear whether naked argentaffin fibrils leave the cells or whether they split away from the main mass of cytoplasm with an investment of the cell body around each fibril. What is clear, however, is that the scanty fibrils of the earlier stage of Hodgkin's disease are direct derivatives of the endothelium. Further examination reveals that there is still another source of the fibrillar material. In addition to the endothelial elements there are also a fair number of elongated reticular cells of the type that normally form part of the boundary of the lymphatic sinuses. Inside these elements there are also argentaffin fibrils, which are more easily visible than are those of the endothelial cells. It is, however, not clear that these intra-cellular structures emerge from the cell body; it seems more likely that they extend all along the ramifications of the elongated processes of the cell without stretching into the tissues in the vicinity. Lastly, the giant cells also show a close relationship to the argentaffin fibrils. The irregular processes of these large elements contain argentaffin material which seems to emerge from the cells and twine among the neighbouring elements. There seems to be no doubt that the late or so-called fibrotic stage of the malady is caused by a conversion of the predominantly endothelial structure into a reticular one. In other words, whatever the objection to the term "reticulo-endothelium," there are distinct advantages about the name, because it so clearly implies the close relationship of the two forms of histiocytic cell and also suggests their demonstrable interchangeability. In this connection reference may be made to certain of the changes occurring when foreign bodies are present in living tissues; if these be sterile there occurs a completely aseptic form of inflammation in which the activity of

histiocytes can easily be observed. Here again there is formation of giant cells which lie in close relationship to the reticulum and which contain argentaffin fibrils. It is not clear why such focal hypertrophy of histiocytic tissue should occur, but one may infer that these large cells are not only morphological giants but are also functionally powerful. This is suggested by the observation that such foreign-body giant cells arise particularly around substances capable of being ingested and destroyed by phagocytosis.

There seems also to be no doubt that the cells of the histiocytic system can become free elements. The nucleus and protoplasm of the sessile cell becomes hypertrophied; soon the nucleus becomes vesicular, and, although the cell is still attached to the reticulum, it bulges into the reticular spaces. Gradually the outlying processes of the cell are withdrawn and a rounded element is set free. It appears that such liberated elements are particularly active; certainly particles of ingested material such as fat and carbon are seen inside them in relatively large amounts.

So much has been written about that special form of histiocyte, the Kupffer cell in the liver, that we need say but little here. It is, however, necessary to point out that recent observation has shown the presence of at least three types of cells in the hepatic capillaries; there is the endothelium proper, then there are branched pericytes lying between the endothelium and the liver cells themselves; and lastly there are endocytes that lie on the inner surface of the endothelium, or even in the lumina of the capillaries; these last are presumably the true Kupffer cells.

There is much argument as to the mechanism by which the liver occasionally regains its embryonic function of blood-formation. Some writers contend that this occurs only by colonisation of the capillaries by multi-potent stem-cells, whilst other investigators are equally emphatic that such myeloid metaplasia may arise *in loco*. Certainly some evidence is available that Kupffer cells may become free and be converted directly in cells characteristic of the blood. Further, some blood tumours of the liver (angiomas) contain immature blood-cells which presumably must have been formed *in situ*, because such growths may occur

in persons in whom no immature blood cells can be found in the circulation, that is, no source for the multi-potent cells can be discovered.

At this stage we are inevitably faced with the problem of the nature of the cell now usually termed a *monocyte*. This element, which forms about 6 per cent. of the leucocytes in normal blood, is still the subject of lively controversy. An origin from myeloid tissue is supported by the users of the supra-vital method of staining. Thus it is stated that the very young monocyte, the monoblast, is quite distinct from the myeloblast. It contains relatively few small mitochondria which lie in the indentation of the immature nucleus. In the mature form mitochondria are much more numerous and are less sharply localised in position; furthermore, a few neutral red granules appear, usually in the nuclear indentation around the centrosome. There is, however, a totally different view, which is that the great majority of monocytes arise somewhere in the circulation from multi-potent haemocytoblasts. This is not quite the same as the contention of the tripartite school which holds that monocytes are derived from a third haematopoietic tissue, the reticulo-endothelium itself; rather, the attitude is that the monocyte is a peculiar manifestation of the ubiquitous "lymphoid" cell beloved of the monophyletists.

The last point in connection with the blood that requires to be mentioned at present is the peculiar specificity of arrangement of the reticulum in the normal blood-forming tissues. For example, the reticulum in the bone-marrow has a special relationship to the blood vessels from which it radiates after having formed an incomplete investment. In spite of this peculiarly typical arrangement there is enormous lability of structure, and innumerable stimuli that affect the activity, and therefore the structure of the bone-marrow results in a rearrangement of the reticulum.

PITUITARY

Recent advances in intra-cranial surgery have made the pituitary gland a subject of great interest and practical importance, so that we are quite justified in devoting some space to reviewing new observations on its cellular composition. First, it must be made

clear that the old rather coarse subdivision of the organ into three parts—pars anterior, pars posterior and pars intermedia—is no longer sufficient for accurate description. The pars posterior has a central part continuous with the hypothalamus, and an outer epithelial covering (pars intermedia) continuous with similar cells in the anterior lobe. Further, a thin zone is spread out from the pars anterior at the base of the brain; this is the important pars tuberalis that was overlooked for many years. The pars anterior or pars distalis differs very little in its structure in different types of mammals. Essentially it consists of columns of cells lying between large vascular sinuses and a very small amount of connective tissue. The chromophile cells of this part stain intensely on account of the presence of very large numbers of granules in their cytoplasm. Two types of granules are present, known as beta and alpha; the former tend to stain with basic, and the latter with acid stains, but this is not really a specific character; there is, however, little doubt that the two types of granules are never found in one cell, and equally transitions from the one to the other form are not known. In man there seems to be no orderly arrangement of the two types of cells, although the alpha ones are much the more numerous. These granules are large and almost completely fill the cell, whereas the beta form are smaller and less distinct and lie in rather larger elements than do the alpha granules. The Golgi apparatus lies in a clear area near the nucleus, and is more easily seen in the beta cells on account of the paucity of granules; equally mitochondria are more easily seen in this type of element.

Then we have to mention the so-called chromophobe cells, which are non-granular. These elements also are of two types; first the smaller form, known as chief or reserve cells. Then there are larger elements, often near the middle of the columns, in which a complex reticulum may be seen. These are supposed to be chromophile cells from which the granules have been lost.

The pars intermedia is almost non-vascular and also contains two types of cells. First, elongated narrow cells stretching the whole width of the pars intermedia, and easily impregnated by

Golgi's method; and secondly, cells closely resembling the chromophobe elements of the pars anterior.

The pars tuberalis is only a small structure in man, but is of great histological interest, because in it may be seen structures closely resembling the cell-nests found in epitheliomata.

The pars posterior is a nervous mechanism in which typical ependymal elements, mossy neuroglial cells and certain large pyramidal cells of uncertain nature can be found. If the last-named are nerve cells, they certainly differ from any others, inasmuch as they contain no Nissl granules. In man only one type of cell is numerous; this is a more or less fusiform element with fragile indistinct process running off from it. Nerve fibres enter the pars posterior from the supra-optic nucleus and form complex whorls around blood vessels or around groups of cells. Some end in hyaline masses, whilst others have an end-bulb reminiscent of that seen at the end of a regenerating nerve fibre; the former structure is not found in the human subject until about the second year of life.

The pathology of the pituitary gland is far better understood from the clinical than from the histological aspect, for, although many changes are known, few have specific characters. In acromegaly there is almost invariably a definite adenoma composed entirely of eosinophilic, *i.e.*, chromophilic cells, whereas the usual adenomata of this organ consist of chromophobe cells and are not accompanied by acromegaly.

THYROID

It is very difficult to determine how much of the recent work on this important endocrine gland should be mentioned here; much of it is of the greatest practical importance, although not strictly within our present purview. The structural unity of the thyroid gland is the individual follicle, although some writers contend that the unit is really a system of closed tubes suspended in a lymph sac. One of the most interesting elements in the organ are the inter-follicular epithelial cells which, in man, normally form small groups in the inter-follicular stroma, particularly in late foetal life and in infancy. These cells are normally destined

to undergo atrophy, but they seem to be able to differentiate in response to a variety of stimuli, and presumably their existence is related to the development of adenomata of the organ.

In the lining cells of the acini the Golgi system usually lies between the nucleus and the lumen, but in a small percentage of the cells this structure lies on the other side of the nucleus.

PARATHYROIDS

These small organs lying so close to the thyroid exert a great influence on many phases of growth, and do not appear to have any functional connection with their much larger neighbour.

There are three types of cells in these glands: clear chief cells, which appear to be the most important elements, and, in man, compose the whole organ up to about the tenth year of life. There is a close resemblance between these elements and the lay idea of a cell because the protoplasm is so pale as to be almost invisible, whilst the cell boundary is quite sharply defined. Large eosinophilic cells with small deeply staining nuclei and very granular cytoplasm.

The third group are probably only manifestations of the chief cells.

Nothing is known as to the diversity of function that may be inferred from the histological characters. Even the situation of the Golgi apparatus does not give much indication as to the direction in which secretion normally occurs, because this structure is so variable in its intra-cellular position. The follicles containing colloid that develop in the parathyroids in later life misled many of the earlier workers into the idea that these organs were nothing more than phases of thyroid activity, but it is now recognised that almost any secretion, when seen in fixed tissues, is morphologically identical with thyroid colloid.

THYMUS

The thymus is one of the most interesting and puzzling structures in the animal body, and we must be excused if much of what we describe is not strictly new, but there is so much confusion about

this organ that a good purpose should be served by going beyond our terms of reference.

It is particularly the small cells of the thymus that present problems of difficulty and importance. These are small elements with scanty cytoplasm and dense nuclei lying in the meshes of the reticulum of the organ. Although these cells have been supposed to be epithelial elements, there can be no doubt that their mitochondria are identical in appearance with those of ordinary lymphocytes, and are quite different and much larger than those of the reticular cells. The last-named are almost certainly the original epithelial cells of the organ. This supporting structure is rather hidden by the multitude of lymphocytes, but after X-irradiation it is well seen, and shows evidence of great activity. The cells rapidly divide, and many multi-nucleated giant cells are formed; both these and the cells of the reticulum are very actively phagocytic. Even in the normal thymus the products of the breakdown of the small cells are ingested by elements belonging to the reticulum.

It is the so-called Hassall's corpuscles that have attracted most attention, because in no other organ are similar structures found. The generally accepted modern view is that these corpuscles arise from the reticulum of the organ, probably from hypertrophic and degenerate elements. In man they are not seen until the second month of foetal life; they then continue to increase until age involution of the organ commences, but it is quite probable that new ones are formed in the thymic remnants throughout life. A corpuscle may consist of a single reticular cell or of groups of the same elements. The appearance of the structure depends upon its age; when young the constituent cells are irregularly polygonal, but when old they are flattened and hyaline crescentic elements arranged around a central part composed of *débris*. Calcification or cyst formation is quite common. The latter condition, which was described in syphilitic infants, is not a pathological state, but may be seen in almost any thymus.

A most interesting constituent of the thymus are the myoid cells, which are fairly common in lower animals, although not often described in the human. There is but little doubt that, in

spite of the transverse striation, these cells are not in any way related to striated muscle ; they are certainly modifications of the reticulum. Indeed, it is sometimes possible to observe a striped appearance even in the degenerate cells of Hassall's corpuscles.

No certainty is possible as to the origin of the eosinophilic granular cells which are always present in the thymus. It is tempting to believe that they, like the small cells or lymphocytes, arise from undifferentiated mesenchyme, but there is more likelihood that they represent immigrated blood cells.

ADRENALS

Like all the endocrine organs much attention has recently been devoted to the suprarenal glands, and although there are no very striking advances to record, steady progress has occurred. It is particularly in connection with pathological changes that our knowledge has recently been enriched. Simple enlargement in size is quite commonly found accidentally at autopsy, and little is known as to its significance, but nodular tumours, innocent or malignant, may be the cause of remarkable changes in the secondary sex characters. A child, obviously a female at birth, may develop the hirsuties of the male, and may even present enlargements of the reproductive organs reminiscent of the external genitalia of the other sex. It appears that only neoplasms of the cortex have this effect ; little or nothing is known of medullary tumours of the adrenal.

That there is a close dependence of cholesterol metabolism on the adrenal cortex cannot be doubted, and there is evidence that the regulation of this process is the work of the cells in the outer seven-eighths of the cortex. The innermost part appears to be concerned with the regulation of sexual function, particularly with the development of the secondary sexual characters. Another indication of the close relationship of the adrenal cortex to the sexual functions is shown by the occurrence of histological changes during pregnancy. Thus there is degeneration of the zona reticularis, with slight hyperplasia of the other two layers. There is also formation of a new stratum termed the zona gestationis.

It is, however, quite possible that these alterations result from

rearrangement rather than true new formation of cells : certainly many writers are far from convinced of the existence of such changes during pregnancy.

MUSCLE

Controversies regarding the structure of muscular tissue are as old as is the science of histology itself ; and many of the arguments are still far from being concluded.

It is admitted that striated muscle is made up of threads along which at regular intervals transverse membrane-like structures occur. Further, it seems fairly certain that the threads absorb fluid from the intervening spaces during the process of contraction ; and as a result there is bulging of the threads between the transverse membranes.

When one considers how similar are the obvious functions of all muscles, it is surprising to find how different is the structure of unstriated muscle from that of the striated variety. It is claimed that in the former there is a distinct chemical change during contraction ; and this is shown by a decreased intensity of staining reaction and a more fibrillar appearance of the fibres. It is regrettable that exactly similar appearances have been described during relaxation, so that all that can safely be affirmed is that chemical changes, manifested as alterations of staining reaction, occur in unstriped muscle at some phase of its activity.

Cardiac muscle, of course, presents peculiarities of its own. It is now generally admitted that the whole of the musculature of the heart is a true syncytium, and, although the information is not all new, we must rapidly review its peculiarities. The fibres possess a sarcolemma outside them and ordinary nuclei inside. Sarcoplasm lies inside the sarcolemma. We do not know the exact diameter or length of the fibres for the obvious reason that their endings cannot be seen. In the uncontracted phase there are to be seen the well-known light and dark discs. The latter contain an anisotropic substance, whilst the former seem to be devoid of this material. The light disc is bisected by a thin line at each end of which is an end-disc. The unit of a fibril appears to be that amount of tissue that lies between two of the thin lines or

disks; these are the telophragmata of Heidenhain. There are many more details of structure described by various writers, but we have here enough for our present needs. Apart from the syncytial arrangement, which differentiates the myocardium from ordinary striated muscle, there is another striking difference. The intercalated disks are transverse structures that are found at intervals of about forty units or sarcomeres. In healthy muscle these are straight and lie right across the width of the fibre, but some travel only a part of the distance, even as little as a quarter. More complicated intercalated disks have a fairly regular step-like arrangement. It is probable that the more complicated forms are accompaniments of advancing age. The most difficult problem is that of the reversal of striation during contraction, and it is still impossible to give an explanation of this occurrence.

The specialisation of contractile function of the bundle of His has led to intensive morphological studies of this vital structure, and, although a good deal is known, the chapter is far from complete. There are three forms of Purkinje cells: some spheroidal with abundant protoplasm and a striated border, others elongated in form with more obvious striation and less bulky cytoplasm; and even more elongated elements with striation occupying almost the whole thickness of the cell. The last variety of cell appears to become continuous with the ordinary myocardium. The cells are stated to possess four layers: a central zone enclosing the nuclei; a granular layer around this, in which the granules stain intensely with iron hæmatoxylin; a stratum with very fine longitudinal striation and practically no transverse striation; and a striated cortex in which the fibrils run circularly, obliquely or longitudinally.

In the human heart it is now customary to distinguish cells of embryological appearance from others of adult type. The former are large polyhedral elements containing several nuclei near their centre. The perinuclear zone is granular, whereas the periphery of the cell is fibrillar. Some of these cells lie, apparently as association mechanisms, between adjacent bundles. Most striking is the fact that these intercalated nodes often form a plexiform arrangement such as that described by Tawara, and now usually

known as the auriculo-ventricular node. It is probable that this is nothing more than such a plexiform collection of intercalated cells which happens to be situated at a point where studies of the function of the myocardium would lead one to expect to find it ; it has attracted more attention than have the other similar formations, simply because its significance seems to be understood, and perhaps in part because it was the first such structure to be discovered.

The other or adult type of cell resembles the ordinary elements of the myocardium very closely, but is always multi-nucleated.

It must be realised that the separation into types of cell is rather an artificial one, because transitions can be found between cells of the embryonic type and those of the adult form just as they can between the latter and the ordinary myocardium.

Section II

MICROSCOPY OF THE LIVING EYE

By BASIL GRAVES, M.C., M.A. Camb., M.R.C.S. Eng.,
D.O.M.S. Eng.

THE interior of the eye is accessible through the clear cornea to inspection as is no other region in the body, revealing as nowhere else normal deep structure and its pathological alterations. The

conjunctiva of the lids is reflected at the fornix, F (Fig. 1) on to the fibrous sclera, S, which it covers as far as the limbus, l, having a loose and elastic connection to the sclera owing to the intervention of lax areolar tissue in which run the coarser conjunctival vessels. The epithelium of this ocular conjunctiva becomes continuous with the epithelium covering the clear cornea, but over the cornea it is immovably and integrally blended with the firm fibrous tissue beneath.

When, as the result of disease of the cornea,

inflammatory processes—cellular and vascular—invade it, they are derived from the superficial vessels of the conjunctiva when the disease is a superficial one, and from the deep vessels of the sclerotic, S, or ciliary body, C, when the disease is of deeper

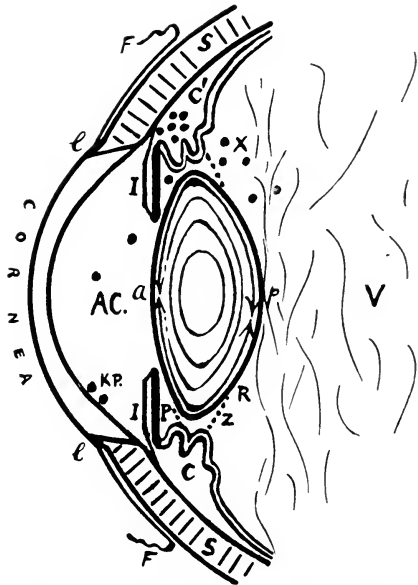

FIG. 1.—Section of the anterior part of the human eye.

origin ; it is clinically of great importance to be able to determine the exact level in the cornea of any pathological processes as well as their nature. The aqueous fluid in the anterior chamber, AC, is secreted by the ciliary body, C, and drained away through filtration channels in the angle between the front of the iris, I, and the back of the limbus, l. In inflammation of the ciliary body, C, cellular products are thrown out ; some, x, find their way into the vitreous fluid, V, and form " dust " particles or larger " floaters " in it ; others migrate forward and are deposited as " keratic precipitates," K.P. (Parsons), on the back of the cornea, where they give rise when gross to a very characteristic appearance wrongly misnamed in the past " Keratitis profunda." Such precipitates, in a very fine form detectable only by slit-lamp microscopy, are often the earliest premonitory sign of oncoming cyclitis. Apart from revealing formed products, the aqueous fluid, in pathological states of the ciliary body, may undergo an increase in its colloid contents revealed by increased visibility of a minute beam of light traversing it.

The iris, I, consists of a translucent anterior layer, the stroma, backed by a pigment-layer, P, which is highly obstructive to the passage of light. In inflammation of the iris its pigment layer may form adhesions, minute or large, to the anterior lens capsule, a, or small detached portions of pigment may become adherent to the lens-capsule, accessible to inspection when the pupil is dilated by a drug. The lens is held in its position behind the iris by numerous fibres from the ciliary body (*e.g.*, Z), which together form the suspensory ligament. The anterior lens-capsule, a, has a curvature of greater radius than the posterior lens-capsule, p. Beneath the anterior capsule there is a layer of cells, and those near the equator are always forming new lens fibres which, continually through life, lay new lens-matter, both front and back beneath the capsule, on to the surface of the deeper material nearer the centre which is always shrinking and becoming more dense. Hence, at any period of life the lens matter nearest the centre is the oldest—that right in the centre is the original embryonic lens-matter—and that beneath the capsule is the latest to have been formed. The lens-fibres, as they grow in from the

equator beneath the capsule (see arrows in Fig. 1), meet and unite along "suture lines" radiating from the axis of the lens. Near the central, embryonic region of the lens these suture-lines are very simple, as in lower animals; but nearer the capsule of the lens where, for a given area, there are more fibres to unite, the suture lines become more extensive by dichotomous branching of the limbs of what, deeper in nearer the centre, is only in the form of a simple Y. The different levels of the substance of the lens, both anteriorly and posteriorly, corresponding with the period of their development are distinguishable in their precise localization by slit-lamp microscopy; the clinical importance of the exact localisation of pathological features seen within the lens is thus obvious.

The vitreous fluid, V, normally contains a tenuous gossamer-like fibrillar optical meshwork, except in the "retrolental gap," R, immediately behind the lens. Pathological processes may occur here and may call for minute inspection, *e.g.*, a neuroblastoma growing from the posterior part of the interior of the eye of a child may be revealed for the first time from its having pushed the retina, which it may have detached, up against the back of the lens; the "cat's eye" reflex which this creates is not always easily distinguished from a rather similar appearance caused by the much less serious condition of "pseudoglioma" due to organised inflammatory exudate secreted behind the lens by the ciliary body, C. When the object seen behind the lens is a detached retina, its arteries will run from the centre towards the periphery of the lens; when it is a cyclitic membrane, its arteries will run from near the periphery, *i.e.*, from the ciliary body, towards the centre. Microscopy of the vessels, revealing the direction of flow of the contained corpuscles, will afford distinction between these two conditions. These few examples will serve to indicate something of the clinical importance of minute inspection and precise localisation of features within the transparent and translucent media of the eye.

For practical clinical purposes, Microscopy of the Living Eye is concerned with roughly the anterior half of the eye, *i.e.*, lids and conjunctiva, cornea, anterior chamber, iris, lens and that part of the vitreous just behind the lens. The subject of microscopy

of the posterior part of the interior of the eye, including the fundus, by the application of corneal contact glasses, much practised in the first instance mainly by Kœppe, will not be dealt with here; it has too many practical difficulties to be of material use in general clinical work; the hand ophthalmoscope and the binocular Gullstrand ophthalmoscope provide more appropriate means of

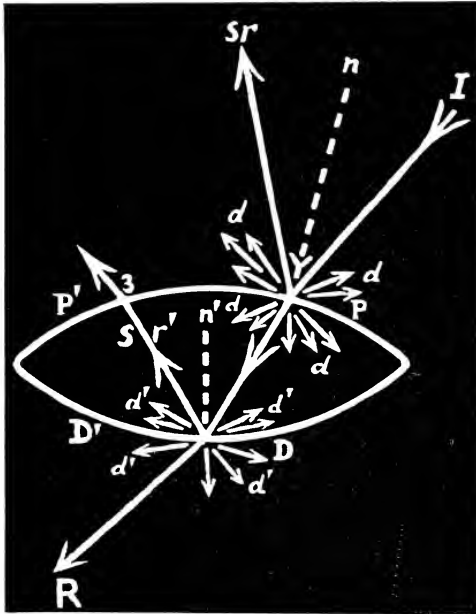

FIG. 2.—Diffuse reflection, specular reflection, and transmission with refraction.

studying the eye fundus of living persons. Passing reference may be made to the study of the angle of the anterior chamber—normally inaccessible to observation—through a corneal contact glass by means of Troncoso's "Gonioscope"; this portable hand instrument is a variety of self-illuminating periscope allowing of observation of a chamber-angle under magnification of low degree. The binocular microscope of Czapski has existed for many

years; it has been put to but little clinical use by ophthalmologists mainly because the visibility of features deep within the transparent tissues of the eye is relatively poor when the area of tissue through which the observation is made is also the path of entry of the illuminating rays; this is unavoidable when beams of light of wide diameter are used.

If an incident beam of light (IY, Fig. 2) strike a polished surface of a block, PD, of a transparent substance like glass, in say, air, some of the light—a high proportion if the surface is highly

polished—is specularly reflected along *sr*, and is of course brightly visible to an observer who takes his view towards and along the direction of *sr*. Some of the light is diffusely reflected in all directions, *d, d, d*, producing, where the beam strikes, a surface patch of light which is visible from whatever direction the observation is made, and this corresponds in size with the cross-section of the beam. Thence some of the light, taking its refracted direction through the substance of the glass, passes along until

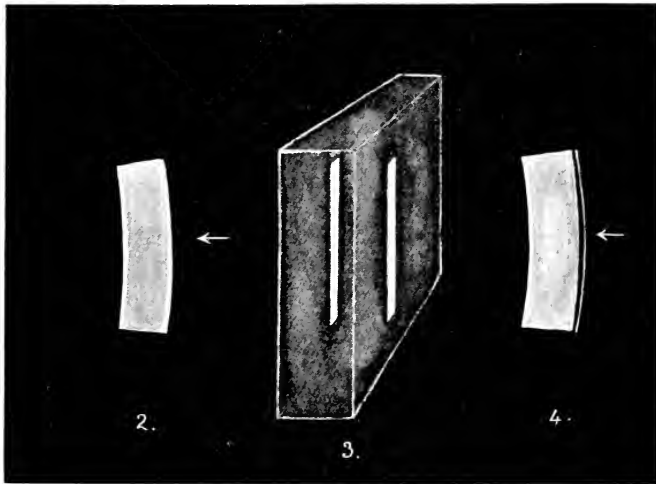

FIG. 3.—2, thin knife-like beam passing through cornea; 4, the same through cornea near limbus; 3, rather wider slit-beam traversing a block of glass in air.

it meets the demarcating distal surface *D* where there is a repetition of all three phenomena provided the glass is in contact also at this surface with a medium differing in refractive index from its own. Thus if a ribbon-like beam of light is passed through a block of polished glass in air, a light-stripe, visible from all directions, is produced by scatter at the entry and exit surfaces (3, Fig. 3) where there is a change in refractive index, and these stripes can be rendered much brighter by increasing the relative surface-irregularity by any such means as passing a greasy finger-tip over the surface.

In the transparent media of the anterior half of the eye there are four very definite smooth surfaces—the anterior and posterior corneal, and the anterior and posterior lental—at each of which, when light enters or leaves, these phenomena occur; but within the substance of the corneal and lental tissues the traversing light does not behave in quite the same way that it does when passing through glass. Glass is physically an optically homogeneous medium, so that the passage of light within it, between the proximal and distal surfaces (P and D, Fig. 2), is invisible under ordinary circumstances (Fig. 3, 3). Transparent living tissues, on the other hand, are not optically homogeneous: for example, the cornea is built up of histological cellular elements so arranged as to admit of as high a degree of transparency as possible, yet each element is in contact with interspaces containing nutrient lymph-fluid whose refractive index probably differs a little from that of the solid elements. Some scatter of light occurs at these multiple microscopic surfaces, the result being a visible internal illumination of the tissue throughout the path of the beam. No term existed in physics which might express this phenomenon, and the word “relucency” has been suggested (6 and 10) for that property of a transparent non-homogeneous substance in virtue of which the path of a traversing beam of light is normally visible, be it due to diffuse internal reflections, scatter, fluorescence, diffraction or any of the other causes which may modify the light so as to render it visible in its interior course; it is not necessary, for clinical purposes, to distinguish between these different contributing phenomena, save that the term relucency should be understood not to include that of specular reflection (sr, Fig. 2), as by drawing this distinction the term has more practical usefulness. It may here be added that, for obvious reasons, the term “visibility” is no substitute for the term “relucency,” visibility being merely dependent on such abstract qualities as contrast; an area almost non-relucient might be highly visible in virtue of contrast with a relucient surrounding area.

The usual simple method of illuminating the eye for observation is to focus obliquely on it, by means of a simple condensing lens, a beam of light from a distant source; the more distant

the source the smaller the diameter of the illuminating beam, and in days gone by many a teacher of ophthalmology, often not clearly as to the actual reasons, would teach the student that to see by oblique illumination many of the pathological features commonly met with in the front half of the eye, he should remove his source of light as far away as was compatible with its intensity. The reason that this gives better visibility is that the observer is usually able to manipulate for his effects with a beam of relatively smaller diameter; but when the 12 mm. diameter of the cornea is considered it may be appreciated that the beam of light, by such simple methods, can seldom be of less diameter than the cornea, particularly with the sources of light which were available to within a few years ago. (The arc-lamp does not seem to have been tried in the past, doubtless partly from fear of danger to the living eye.)

Let such a relatively wide beam of light (I, Fig. 4), as through a simple condensing lens from an ordinary lamp, be focused through the cornea

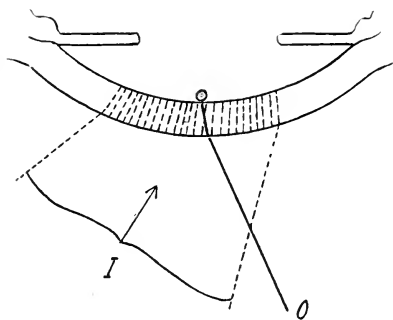

FIG. 4.—Observation of K.P. illuminated by a wide beam of light.

for detection and observation of a spot of K.P. on the back face; the precipitate is illuminated, but the observer, taking his view along the direction O, is first obstructed visually by (a) the dazzle of specular reflection from some part of the curved corneal surface under illumination, and by (b) some diffuse reflection from all the anterior corneal surface (and also the posterior corneal surface) under illumination, and also by (c) the internal illumination of the tissue owing to its relucency; secondly, he is handicapped because the visual background of the lens (not drawn), or it might be the iris, is inevitably illuminated as well. To summarise, the visibility of the spot of K.P. thus illuminated is poor, owing, firstly, to impairment of the transparency of the normal corneal tissue in front caused by the entering light pass-

ing through the area of tissue through which observation must be made—a difficulty usually much intensified if pathological processes have modified the surfaces or the interior of the cornea—and, secondly, to the unavoidable illumination of the visual background. Any trained clinical observer knows that he can usually see a spot of white K.P. much better if he holds his condensing lens so as to focus the light on to the sclerotic near its junction with the cornea, or on to the junction itself (Fig. 5). The reason of this is that the transparency of the area of corneal tissue through which observation (O) is being made is not impaired by the transmission of direct light, and the visual background (I)

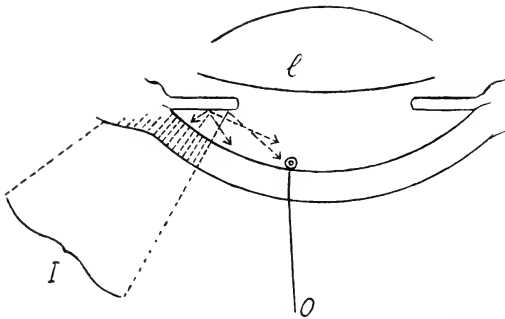

FIG. 5.—Observation of K.P. by light focused on the limbus.

is unilluminated. It may be asked how the spot of K.P. is illuminated; it scatters light which reaches it indirectly by two ways, firstly by diffuse reflection from the surface of the iris (Fig. 5), and secondly by light which travels from the sclerotic meri-

dionally along the cornea by total internal reflections—the method of “sclerotic scatter” which will be explained later (Figs. 33 and 34). The first of these two factors could therefore be employed exclusively if we dealt with a beam having a very restricted diameter, as in Fig. 6, in which, for illustration purposes, the feature for observation has been drawn inside and not behind the cornea. “Retroillumination” (R.I.) seemed an appropriate term for this method (6), but in England the term “transillumination” of the Continental writers is usually preferred; and given the required conditions, retroillumination may afford observation of a bright feature against a relatively dark visual background (as in Fig. 6) or of a relatively dark, opaque or non-relucent feature against a light visual background, as in

Fig. 7, in which an illuminated sectional area of the relucent lens-tissue is chosen as the visual background. Such a small and intense beam may be employed to yield other equally valuable illumination-effects, but before these are discussed it is better, at this stage, to describe the diaphragm-lamp and its principle of production of a small beam of light of any desired shape and size in cross-section.

A point-source of light and a condensing lens will yield, in the position conjugate to the point-source, a focal beam of small diameter; but the size and shape of the point-source cannot be varied at will so as to alter the size and shape of the beam at the conjugate focus. If, however, the light from the point-source (*s*, Fig. 8) is collected and focused into a small diaphragm-aperture, *p*, of variable size and shape, then this aperture may be used as a source from which to form, by a focusing lens, **FL**, a beam whose size and shape can be varied in accordance with

the size and shape of the diaphragm-aperture; the beam at *f*, the conjugate focus of *p*, will have the shape of the aperture *p*, but be of smaller cross-section, in conformity with the usual laws relating to conjugate foci; the shorter the focus of the lens, **FL**, the smaller the diameter of the beam at *f* in relation to a given diameter for the aperture *p*. In the Gullstrand slit-lamp the aperture *p* is in the form of a vertically set slit whose jaws may be opened or shut so as to provide a slit-aperture whose width can be varied at will; the source of light, *s*, is a vertically disposed condensed spiral filament. In the original form of the lamp an image of the filament was focused into the aperture *p*, *i.e.*, *s* and *p* were con-

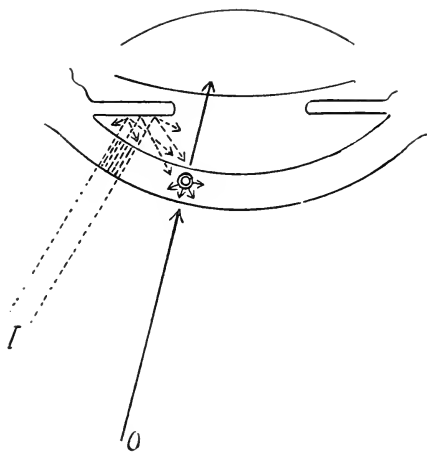

FIG. 6.—Retroillumination.

jugate foci in relation to the collecting system *c*. The focusing lens, **FL**, had a large aperture and was not achromatic, so that the beam at *f* showed chromatic aberration; and it had another defect: *f* and *p* being conjugate foci, and an image of the spiral filament of the lamp being focused into the slit at *p*, a second image of the spiral filament was again reproduced in the beam at *f*, *i.e.*, the beam at *f* was not homogeneous unless a homogeneous light-source were used, such as the glowing end of one carbon of an arc-lamp instead of a spiral tungsten filament. These defects of the beam at *f*—in respect of chromatism and light-distribution—were subsequently corrected in this way: As more efficient filament-lamps came on the market they could be burnt at a greater intensity, and this allowed of the focusing lens having a much smaller aperture so that it could be made in achromatic form. The second error, resulting from the ultimate projection of an image of

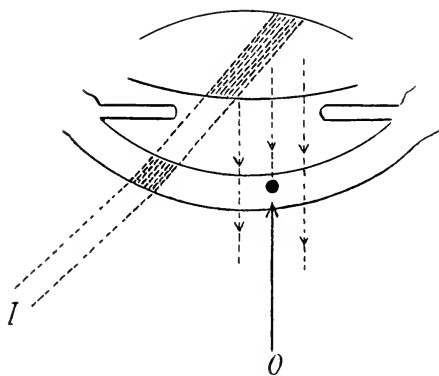

FIG. 7.—Retroillumination.

the spiral filament into the beam at *f*, was overcome by Vogt's arrangement of the apparatus; he had the lamp bulbs made so that the spiral filament, *s'*, could be pushed closer to the collecting system, *C*, until the image of the filament was projected on to the plane of **FL'**, *i.e.*, *s'* and **FL'**, instead of *s* and *p*, now became the conjugates in respect of the system *C*. The image of the filament, no longer being in the aperture at *p'*, is not reproduced at *f'*, the conjugate of *p'* in respect of the lens **FL'**; *i.e.*, the beam at *f'* is for all practical purposes now homogeneous. In the diagram, Fig. 8, which is drawn from the form of the Gullstrand slit-lamp made by Messrs. Zeiss, also in the photograph of the same apparatus in Fig. 9, **K** is the lamp switch (12); *a, a, a*, are screws for centring the lamp-filament about the optical

axis, O ; L is for locking the lamp-casing in position once it has been pushed or pulled, and twisted, into the correct position so that the image of the lamp filament S is both correctly focused and vertically set ; T is for locking the body of the slit-lamp in its encircling collar ; A is for locking the diaphragm-plate after it has been set with the slit disposed in any desired axis, though this is nearly always used vertically set ; p represents the plane of the slit, whose width can be increased or diminished by the screw W (it is better, by loosening first the screw T, to rotate the whole

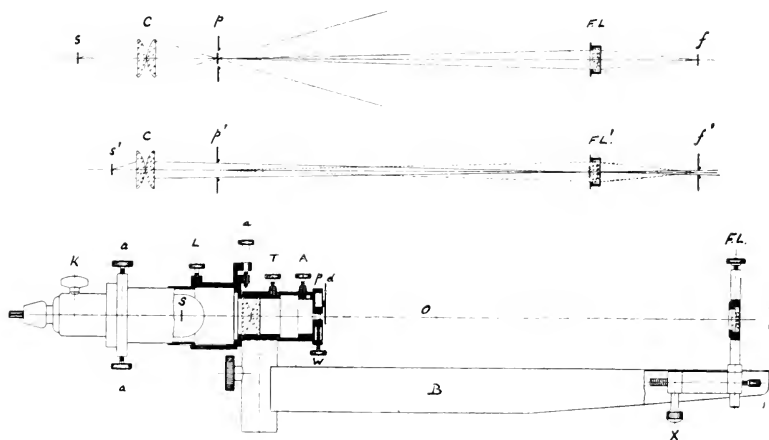

FIG. 8.—Slit-Lamp.

body of the apparatus round so that A lies underneath and W is on top where it is more accessible for manipulation); d is an accessory diaphragm-plate mounted on a spindle and having round or square holes of different diameter, any one of which may be rotated into the optical axis when a small round or square beam is desired instead of a ribbon-like beam from a slit, the jaws of the slit then being screwed wide apart so as to leave free access to the round or square aperture. B is a long arm supporting the focusing lens FL, which can be racked horizontally to and fro by means of the screw X ; Y (Fig. 9) is the Arruga fitting, enabling the lens FL to be moved up and down along a vertical direction. The lens FL is set in front of a rectangular diaphragm-plate having

a rectangular aperture in the centre (Fig. 10). It is necessary for proper adjustment of the apparatus that the lamp filament should be correctly focused, and set (in respect of "twist"), and centred (by the screws *a, a, a*), and finally locked (by the screw *L*), so that the image of the filament is in focus on the diaphragm-plate of the lens *FL*, and vertically set, and centred on the aperture in this

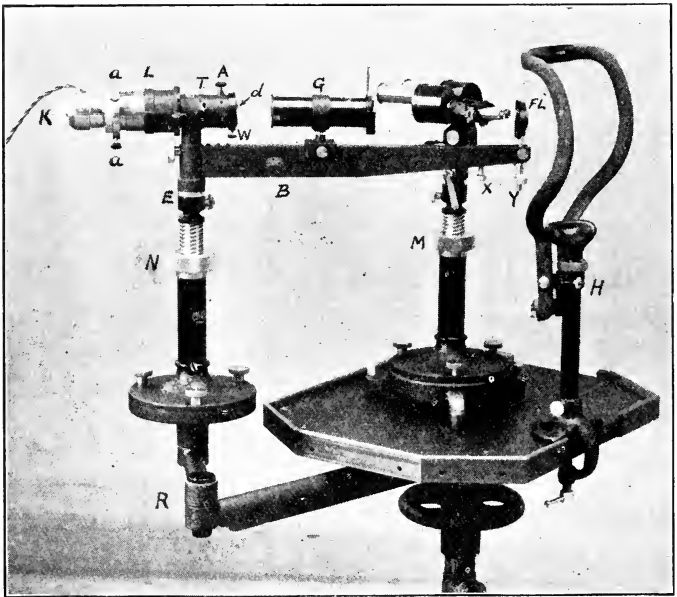

FIG. 9.—Zeiss Model of the Gullstrand Slit-Lamp and Czapski Binocular Microscope.

plate, as in E. Fig. 10, in which A, B, C and D represent errors of adjustment in one or other of these respects. The slit-lamp is mounted on a jointed swivel-arm, R (Fig. 9), which provides for variable direction and for coarse adjustment of the focusing of the beam on to the eye under observation, the final and fine adjustment of the focusing being accomplished by the screw X (Figs. 8 and 9). I like the means of coarse adjustment of focusing provided in the Bausch and Lomb slit-lamp, *viz.*, by mounting the arm B in runners so that its optical length can be varied at will. It may

be pointed out here that the part of the beam used is the focal region (f , Figs. 8 and 11), and the learner must accustom himself to judge the accurate focusing so as not to be working with the prefocal or postfocal region of the beam. The lens FL is usually of either 10.0 cm. or 7.0 cm. focal length; the shorter the focus of the lens the nearer must it be placed to the eye under observation, and the more abrupt, and more easily appreciated, will be the transition to the focal region of the beam from either the

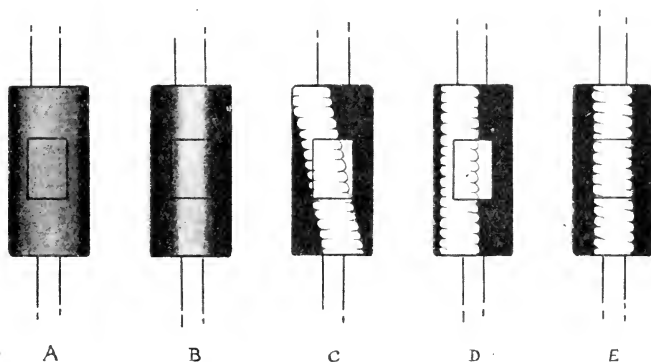

FIG. 10.—Common errors in focusing, setting and centring of the filament image on the diaphragm of the focusing lens. A—image out of focus, the lamp being too far from collecting-lens; B—image out of focus, the lamp being too near collecting-lens; C—image in focus but incorrectly set so that when the vertical Arruga screw is used the diaphragm-aperture runs off the image; D—image in focus, but incorrectly centred; E—image correctly focused, set and centred.

prefocal or post focal regions (Fig. 11). The height-adjustment of the illuminating beam is provided grossly by the milled-head N (Fig. 9) on the upright column, and finally and finely by the screw Y acting on the focusing lens which, when the filament-image is correctly focused, set and centred (as in Fig. 10, E), is readily moved up and down in the vertical plane of the diverging beam which has emerged from the body of the slit-lamp. Swivelling of the lamp is provided at E (Fig. 9); G is simply a diaphragm-tube to cut off redundant light, and one end of it is sometimes fitted with a rotatory screen (not shown in

this photograph) bearing Koeppe's colour-filters, *e.g.*, a red-free filter for use in examining blood vessels, and other colours for use in examining the iris and other parts, but this filter is of no practical use with the filament slit-lamp; its use necessitates a more powerful light-source such as an arc-lamp. The chin and head-rest for the patient under observation are shown in H, Fig. 9.

The binocular stereoscopic microscope (Fig. 9, M, and Fig. 12) is supported by a footpiece which stands on a glass-topped table; this simple arrangement, in which coarse adjustment of the position of the microscope is made with great ease and simplicity, is far more suitable than having the microscope mounted on a

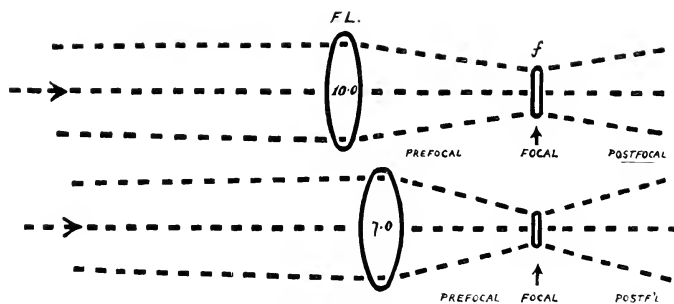

FIG. 11.—Influence respectively of the 10.0 cm. and the 7.0 cm. focusing lenses on the configuration of the focused slit-beam.

mechanical stage with crossed rack adjustment. The microscope is supplied with binocular eye-pieces, usually of two alternative powers, and with three binocular objectives, giving magnifications ranging from $\times 9$ to $\times 45$; for routine clinical work one magnification, $\times 9$, and a second, $\times 24$, is the most satisfactory combination to have. The mistake is commonly made of using too high a magnification for work on the living eye; the lowest, $\times 9$, seldom used, is one of the best because its field just covers the diameter of the cornea. One eye-piece can be fitted with a micrometer-scale for recording measurements. There are other makes of slit-lamp on the market, some good, some with the general fault of being too elaborately constructed in respect of means for their mechanical adjustment, the maker losing sight of the fact that the clinical observer wants simple and easy means of adjustment in relation

to what may always be a shifting object. Elaborate means of mechanical adjustment could admittedly have their use for observation of non-living and still objects. For Zoological laboratory work, *e.g.*, the study of living transparent and translucent tissues of lower types, it would obviously be desirable to have an apparatus constructed and mounted so that the axis of illumination and observation could be set in a vertical plane at will, to permit of the study of tissue media beneath the surface of water or saline in a suitable container; and adjuncts readily suggest themselves for providing suitable stability and adaptability for photographic work on still objects.

Fig. 13 represents Mayou's mounting of a modified Gullstrand Slit-lamp and Czapski microscope, made by Messrs. Theodore Hamblin, Ltd.; and Fig. 14 represents Fincham's pattern made by Messrs. Clement Clarke & Co., Ltd. In the United States of America a well-known apparatus is made by the Bausch and Lomb Optical Company.

The subject of what can be done, given a controllable and minute illuminating beam, was left on p. 39 and may now be resumed. Retroillumination (RI) has been referred to (Figs. 5, 6, and 7), and whilst more will be said of it (Figs. 35 to 42 *et seq.*) it will be best first to describe other methods of illumination. When the beam is very minute in diameter, particularly its antero-posterior oblique diameter, *i.e.* in the direction of O-VB (Fig. 15),¹ it is possible to illuminate directly, *e.g.*, a precipitate on the

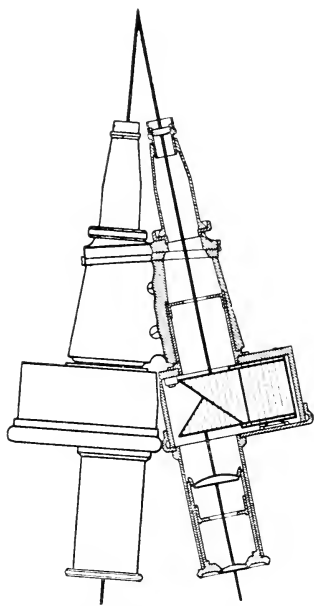

FIG. 12.—Czapski Binocular Microscope.

¹ In the use of anatomical terms here, it is assumed that the object—the patient—is in the upright position, and that the axes of the illuminating beam and microscope are set in the horizontal plane.

back of the cornea and still to observe it (O) both through an area of corneal tissue in front whose transparency is not impaired by the passage of the illuminating rays, and also against an unilluminated visual background. It should be noted that this diagram (Fig. 15), representing a horizontal section through the illuminated eye, serves to depict either a ribbon-

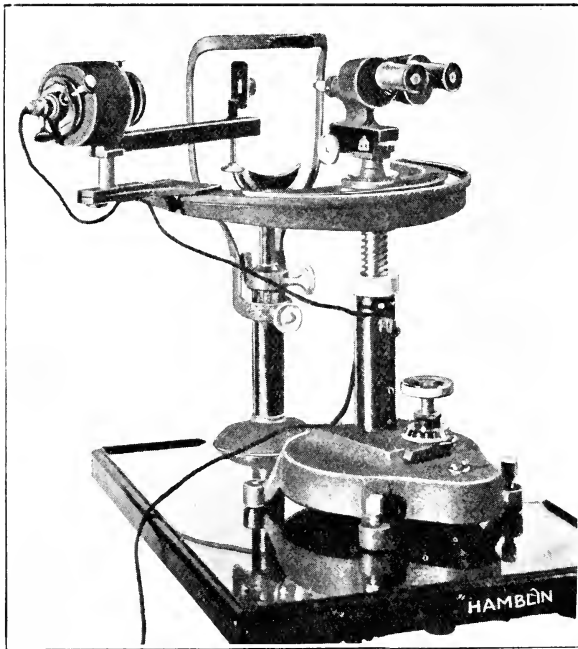

FIG. 13.—Pattern of slit-lamp and of the Czapski binocular microscope, made by Messrs. Theodore Hamblin, Ltd.

like beam issuing from a vertical slit, or a minute round or square beam, the only difference being the very practical one that the slit beam, with its more or less limitless vertical range, can illuminate a much greater vertical area for observation, whilst still affording the required principles of restricted illumination. It will also be noted (Fig. 15) that the observer has chosen his line of observation, O, in a direction to avoid the dazzle along the axis of specular reflection (sr) from the mirror-like epithelial

surface of the cornea. If the incident and reflected beams, I and sr , make a wide angle to one another, the observer may equally avoid dazzle from the reflected beam by taking a line of observation across its aerial reflected path, *i.e.*, allowing sr to cut across the observation axis to the other side of O ; or he may arrange the incident beam radially along the normal to the surface so that the reflected beam comes back along the incident path of the entering light I . The method depicted in

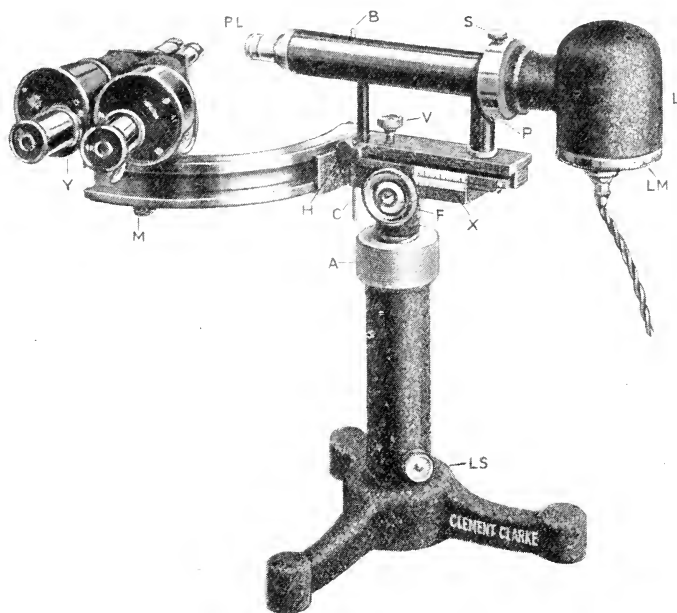

FIG. 14.—Fincham pattern of Gullstrand slit-lamp and Czapski binocular microscope, made by Messrs. Clement Clarke & Co., Ltd.

Fig. 15 may be called that of observation by “direct illumination” (D.I.) (6 and 10).

It has transpired that in this method the clear illumination of the feature under observation, say the spot of $K.P.$ of Figs. 15 and 16, is not the only valuable result of working with a sharply restricted illuminating beam: owing to the relucency of the transparent cornea and lens, the traversing beam defines its own

path in so clear a manner as to demarcate a sectional area of tissue affording a very precise means of localising the level of the K.P. and of other such features. This sectional path of the beam is shown in Fig. 15, and in perspective in Figs. 16, 18, 25, 44, 46, 49, 50, etc; but it must be understood from the beginning that this sharp-cut clear sectional illumination occurs only at the precise focal region of the beam; *i.e.*, if the observer wants this effect in the cornea or in the anterior part of the lens or in the posterior

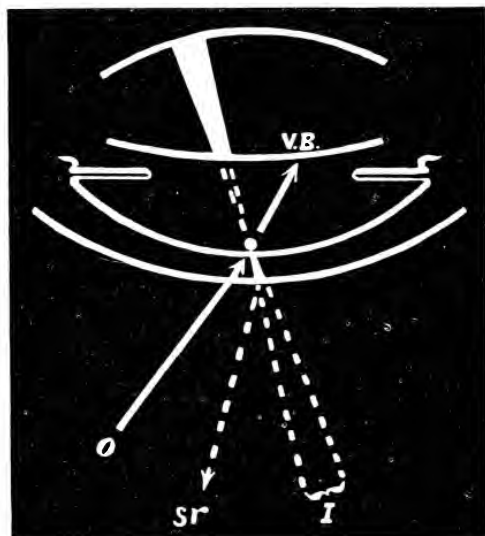

FIG. 15.—Illumination-beam traversing cornea and lens; observation of a spot of K.P. by direct illumination.

part of the lens, he must so adjust the beam that its focal region intersects the area concerned. This is shown in Fig. 15, where the cornea is intersected by the focal region; but in Figs. 6 and 7 this focal property of the illuminating beam has not been depicted. A sharp-cut illumination effect, as depicted in Fig. 16, in both, *e.g.*, the cornea (C) and lens (L) at the same time, is not obtained in practice any more

than focused observation through the microscope is obtainable at more than one level of tissue at the same time. The beginner should grasp this essential fact from the outset and learn to manipulate the focusing adjustment of the lamp, finding and maintaining his levels, just as he does when focusing for observation through a microscope; in slit-lamp microscopy one hand is always controlling the directing and focusing of the illumination and the other hand is controlling the microscope. The illumination-effect produced in either cornea or

lens by the slit-beam is shown in Fig. 16A, and by the small round beam in Fig. 16B, it being understood that the sharp focal effect shown would not be obtainable in both cornea and lens at the same time.

Dealing now with the cornea, it will be seen that the area traversed by the small round focal beam has the form of a clear-cut solid cylinder (Fig. 16B: c) with front and back ends well defined by the anatomical faces of the cornea; when the focused slit-beam is used the sectionally illuminated area appears as a solid curved four-sided block (Fig. 16A: c); and the relationship of the spot of K.P. to this traversing cylinder or block, particularly when judged with the added aid of binocular stereoscopic

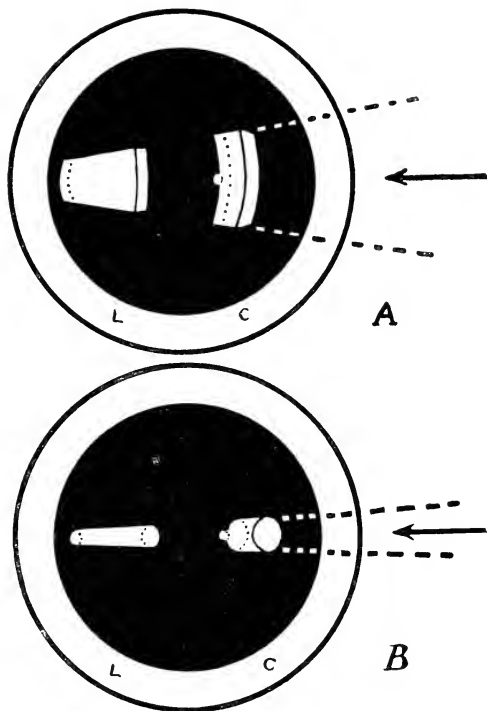

FIG. 16 —A: Wide slit-beam; B: Small circular beam, illuminating a spot of K.P. on the deep face of the cornea. Beam in cornea (c) and lens (l).

observation, affords a very precise means of localisation of the level of the K.P. The corneal block is diagrammatically represented in Fig. 17; the sharpness of the actual outlining is not exaggerated, but the diagram differs from the reality in not showing uniform internal illumination of the relucient area enclosed by the outlines. The block has two coronal faces, abde, anatomically anterior or superficial, *i.e.*, proximal to the observer, and efhg, anatomically

posterior or deep, *i.e.*, distal from the observer, both these faces being curved in conformity with the curves of the cornea; and two more faces, both of them lateral, each, the lateral face proximal to the observer, and *fbdh*, the lateral face distal from the observer. It will be noted that the superficial face *abde* and the proximal lateral face *eacg*, together with all their bounding edges, are seen in unobstructed view; but the remaining faces *cfhg* and *fbdh*, together with their remaining bounding edges,

particularly the edge *fh*, are necessarily seen less distinctly because they are viewed through the illuminated substance forming the "block" of the moment.

It has been said above that the block is uniformly illuminated throughout its substance; in the case of the human cornea the relucency of the tissue within is not quite so intense as the relucency of the front and back surfaces; hence the front and back faces of the block are a little brighter than the area which they enclose between them. Pathological features seen in the block stand out stereoscopically with great precision in their relation to one another when viewed under magnification through the binocular microscope; and their absolute localisation as regards their

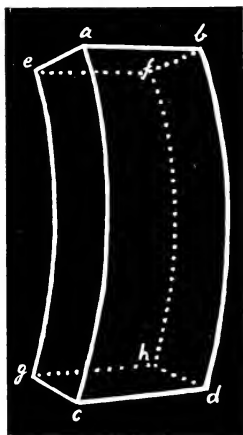

FIG. 17.—Edges and faces of the illuminated corneal block.

depth within the tissue—a very important matter in clinical ophthalmology—is very largely evident by their stereoscopic relationship to the four-sided block; but it is not desirable for purposes of precise localisation to estimate depth solely on this evidence. The exact estimation of depth should be made when the observed feature is brought just within the proximal lateral face of the block (*eacg*); thus, if a vessel is seen emerging from this face of the block at a point just one-third of the distance between front and back edges of the face, then, whether viewed monocularly or binocularly, this estimation represents the exact level of the vessel at this point between the front and back face of the

cornea. Similarly, in Fig. 16A, e, the spot of precipitate is proved to be on the back face of the cornea if it occupies the position drawn when it is in the plane of the lateral face of the block proximal to the observer, whether the observation be made monocularly or binocularly. If, instead of working in a "block" of illuminated tissue, we narrow the slit so that the lateral faces of the block come closer and closer to one another, we narrow the width of the block until it becomes a thin lamina making what Vogt has termed an "optical section." A comparison of corneal

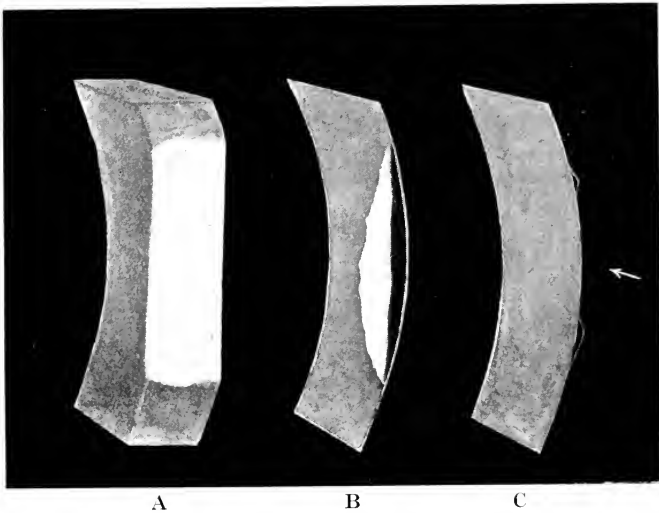

FIG. 18.—A, Nebula of the cornea giving optical appearance of flattening of the anterior face. B, Thin optical section through nebula of the cornea. C, Thin optical section through thin superficial "bullæ" of the corneal epithelium.

sections with the corneal "block" (but with pathological alterations) will be seen in Fig. 18, and another corneal section, with pathological features, is shown in Fig. 44, D. It is always best to use such thin optical sections for localisation of features under direct illumination; their primary detection, if by direct illumination, may be best done in either the wide beam in some cases, or in the thin section in others, according to the nature of the feature and of its immediate surroundings.

After what has been said about the cornea, little need be said on the subject of direct illumination in the lens, either by the wide beam, or by the thin optical section, or by the small cylindrical beam; the first and last are depicted in Figs. 16 and 49, B; thin optical sections of the lens are shown diagrammatically in Fig. 30. A, B, C, the patient being supposed to be looking somewhat upwards in A, horizontally in B, and somewhat downwards in C. Sections depict how the posterior capsular surface has a curvature of shorter radius than the anterior capsular surface. The human lens, in thin optical section, reveals anatomical zones defined by thin curved lines of increased relucency. First a subcapsular line almost concentric with, and very close beneath, each lens-capsule; the anatomical significance of this line is not quite certain because the space between it and the surface far exceeds the thickness of the capsule. Next in order, proceeding towards the centre of the lens from either the anterior or posterior capsule, comes a senile or adult demarcating zone representing the limit of the new cortex laid on beneath the capsule in adult life; next a boundary (at the approximate level of the upright and inverted Y sutures respectively) which marks the demarcation between the cortex of childhood and that—the most central—of the intranatal period. These zones, with the exception of the subcapsular, are not always clearly defined with ease.

It is important to remember that anatomical disturbances early in the course of the optical section of a relucient transparent tissue may produce artificial optical effects in the deeper region of the section which must not be misinterpreted as being anatomical features. Thus, partly obstructive features, like blood vessels cutting the thin optical section of the cornea rob the light from the region of the section axially beyond them and produce "shadow-streaks" (Fig. 43, X) running back parallel with the optical axis of the slit-lamp. These may be distinguished from shadow-streaks due to dust or particles bridging the jaws of the slit of the lamp by the fact that they are stationary when the focusing lens is moved up and down, whereas they move with the lens when due to particles in the slit. Shadow-streaks in the optical section of the lens caused by a pathological change in the anterior cortex

are seen in Fig. 49, A. If the apparent flattening of the anterior corneal face, in Fig. 18, A, were a true flattening, it would probably produce an optical distortion of the deep face of the block, such as is sometimes quite difficult to distinguish from real distortion. An inexperienced observer studying with high power the deep face of the cornea can be misled into describing supposed pathological features which are no more than optical illusions produced by shadow effects cast by true change of this superficial face (see Fig. 45, A).

The examination, by direct illumination, of the fluid inter-

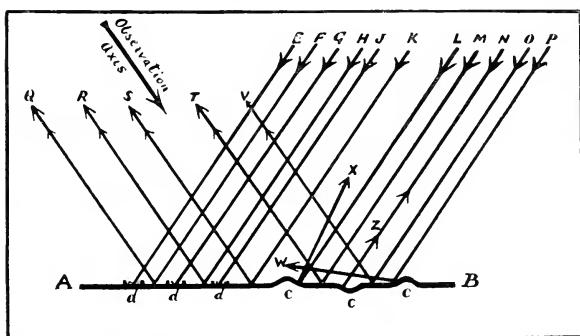

FIG. 19.—Reflection from a polished surface whose specular qualities are impaired at d, d, d, and whose contour is altered at c, c, c.

spaces—the anterior and the vitreous chambers—will be referred to later.

Another aspect of direct illumination must now be referred to; it concerns the study of the four highly smooth specularly reflecting surfaces—the two corneal and the two lental. Everyone is familiar with the ordinary means resorted to of looking for patterning or graining on a polished or semi-polished surface, *viz.*, so to dispose the area observed that it constitutes a reflecting surface from some source of light to the observer's eye; thus may be seen the graining of certain finished surfaces of leather—when the graining is due to truly superficial irregularities—or superficial scratches on a polished wood or metal surface. It is well to consider the simple manner in which these features are thus revealed. In

Fig. 19, let E to P represent rays of a beam of light incident on a highly polished mirror-like surface AB; let d, d, d represent areas of defective reflection due, say, to impairment of the polish; let c, c, c represent small elevations or depressions whose polish is unimpaired. Rays of light such as F, H, K, M, O falling on areas of normal polish and contour will be specularly reflected along the prescribed axes Q, R, S, T, V, respectively, and if such regular reflection predominates from the surface as a whole, an observer, taking his view along the general axis represented by Q, R, S, T, V, will see a shining patch; *i.e.*, he will be viewing an area of the surface AB in the axis of its specular reflection. Rays such as E, G and J, falling on the areas of defective reflection d, d, d, will not be specularly reflected, but either diffusely reflected or absorbed, and in either case the areas d, d, d will appear as dark spots in the shining patch. The rays L, N and P will be specularly reflected in the directions X, Z and W respectively, every ray falling on the areas c, c, c being reflected in a direction different to that of the observation axis; with the exception that the rays from a small area of the summit of the concavity, or bottom of the convexity, both of which conform to the general disposition of the surface AB, will be reflected along the observation axis. Hence the areas c, c, c will also appear as dark spots on the mirror surface with probably (depending in the shape of the areas c, c, c) a minute bright glint in the centre of each. It can be said that the area AB is being viewed, and certain peculiarities detected, by "direct illumination with observation along the axis of specular reflection" ("D.I.S.R." (10)). This principle may be applied to study the two corneal and two lental surfaces. Let MP (Fig. 20) be a plane mirror-surface, M'C a concave mirror-surface and M"V a convex mirror-surface on to an area of which (x) the illuminating beam is directed along the axis IX. Observation of the area x along any such axes as O2, O1, O3 will be by DI, but only along the axis O will observation be by D.I.S.R., and the picture of the area x in this last instance will be entirely different to that in the other instances; observation along O affords very sensitive means of detecting various minute changes and irregularities on the surface.

The two corneal and the anterior lental surfaces are convex; the posterior lental surface is concave. The anterior corneal surface is a highly efficient mirror—or rather the normal film of moisture on its surface is such—because it is very smooth and also because there is a relatively high difference between the refractive index of the moisture on its surface and that of the air in contact with it. The posterior corneal surface is a less efficient mirror for the main reason that the difference between the refractive indices of the cornea and the aqueous fluid is less pronounced; so we get a dazzling bright view of any area of the anterior corneal surface seen by D.I.S.R., and a much duller view of the posterior surface by D.I.S.R. The anterior lental surface viewed by D.I.S.R. is moderately bright, but although the lens-capsule is very smooth the reflecting properties are a little complicated probably by the fact that immediately beneath the very thin capsule lie the living cells and close next to these the lamellæ of lens-fibres, which doubtless makes the surface reflection a composite one; so that even the normal anterior capsule viewed by D.I.S.R. presents a characteristic patterning. The normal posterior lens-capsule has a fairly bright uniform coppery or golden lustre by D.I.S.R.

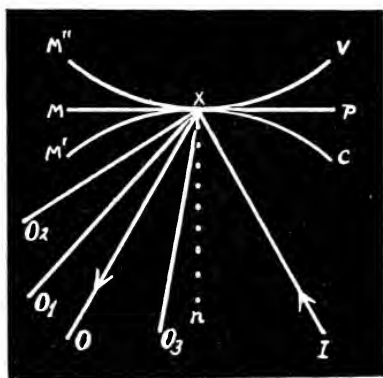

FIG. 20.—Observation of a small focally illuminated area, x , of a plane or curved surface along different axes, that of O being along the axis of specular reflection.

Of all these four surfaces the two which most nearly approach mirror-perfection are thus the anterior corneal and the posterior lental, the one convex and the other concave. The former forms mirror images behind it, and the latter in front of it. When the observer is searching about with the focusing adjustment of his microscope to view one of these two surfaces by D.I.S.R., he will frequently come upon a mirror-image of the diaphragm-aperture

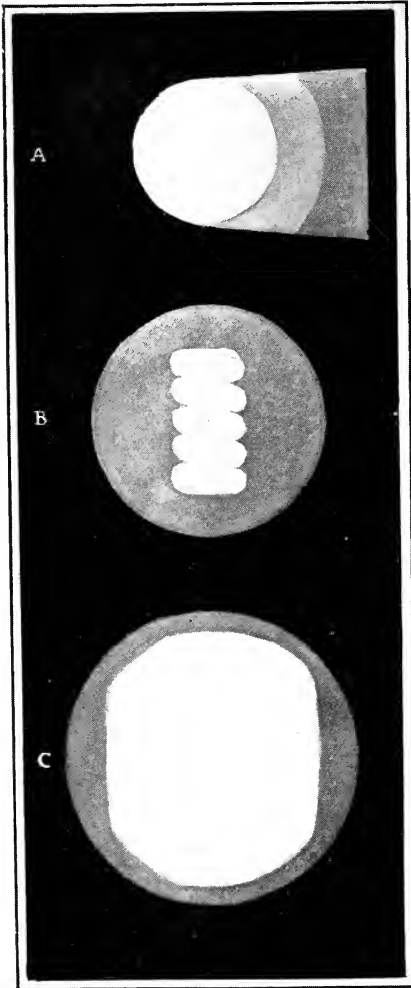

FIG. 21.—View as seen through the microscope along the axis of specular reflection from the posterior lens capsule. A, when the microscope is in visual focus on the plane *pc*, Fig. 22; B, when focused on the level of *X*, Fig. 22; C, when focused on the level of *d* or *p*, Fig. 22.

of the focusing lens (filled by an image of the filament of the lamp which is projected into this aperture); this image, in the case of each surface, lies, it may be said very roughly, about the level of the anterior lens capsule. Hence, if the observer sees this image in focus through his microscope when he is trying to observe the anterior corneal surface by D.I.S.R., he will know that he must now rack the microscope on to a plane nearer himself in order to bring it in focus on the corneal surface which is creating the mirror-image; whereas, if he is studying the posterior lental surface by D.I.S.R. and he sees the focusing lens image he must rack the microscope away from himself in order to focus it on the surface which is creating the image. Thus, with a small round beam accurately focused (illumination-focus) on to the posterior lens-capsule, the view of the area by D.I.S.R. would be represented by the round patch in A (Fig. 21), provided that at the same time the micro-

scope (Fig. 22, pc') is in focus on that patch (Fig. 22, pc). If the microscope (X') is in visual focus on the level X , then the picture seen will be that of B (Fig. 21). If the microscope (d' or p' , Fig. 22) is in visual focus on the levels d or p , the picture seen will be something like C (Fig. 21); in Fig. 21, B and C are merely optical effects seen along the axis a' (Fig. 22), and only the pre-

precise conditions which create and render visible the view A (Fig. 21) will allow the observer to study the area of the lens-capsule (pc , Fig. 22) by D.I.S.R. It is of more than theoretical importance to grasp the significance of these images, because it is frequently not at all easy for the observer to know at what level his microscope is focused when he is searching about to view an area by D.I.S.R., and a knowledge of the level of the mirror-image will always help him to find the level of the area creating that image. Similar principles apply to the study of the anterior corneal mirror-surface and its image.

When we come to observation of the deep, *i.e.*, endothelial, face of the cornea by D.I.S.R. (Fig. 24), the area seen thus has a fairly bright golden lustre, though it is relatively much duller than that of the vividly reflecting epithelial surface; and it is beautifully carpeted by a minutely patterned mosaic representing the outline

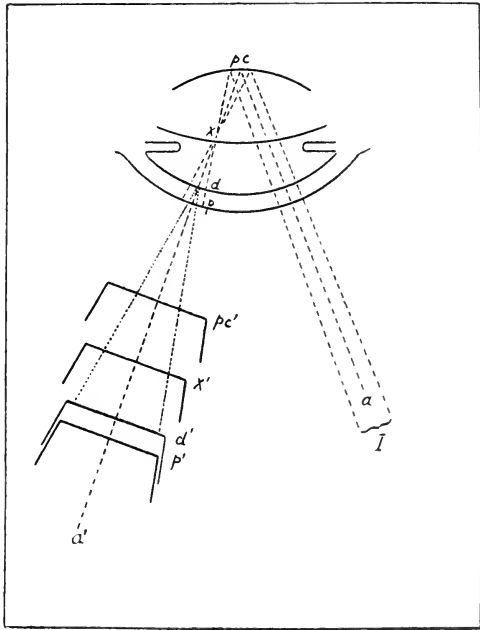

FIG. 22.—Observation along the axis of the specularly reflected beam from the posterior lens-capsule.

of the single-layered flat hexagonal endothelial cells (Fig. 25). This view of the endothelium by D.I.S.R. is to be seen almost at the same time as, and—in the course of the illuminating beam—close behind, the area of the epithelial surface also under D.I.S.R. ; but the two views are not quite coincident because the radii of curvature of the two corneal surfaces are not quite equal. Thus it follows that under conditions in which a small area of the epithelial (anterior) surface is being correctly viewed by D.I.S.R., the corresponding area of the endothelial (posterior) surface in the illuminating beam

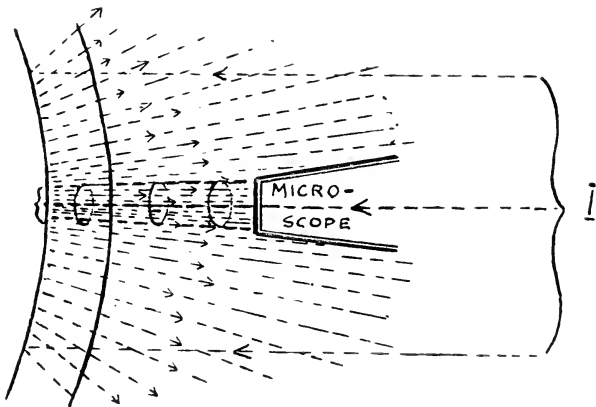

FIG. 23.—Specular reflection of an incident slit-beam, I, from the endothelial face of the cornea.

just falls short of being so disposed as to be seen effectually by D.I.S.R., the axes of the reflected rays from the two being not quite parallel ; and *vice versa* when an area of the endothelial surface is under examination by D.I.S.R. This fact facilitates viewing of the endothelial surface, since the dazzling from the bright anterior surface would be very confusing if it were unavoidably seen to full effect at the same time. Although specular reflection occurs from all the area of the posterior (Fig. 23) and anterior corneal surface upon which the focused beam is incident, the area seen by D.I.S.R. at any one time is never a large one because the curvature of the cornea prevents rays, specularly reflected off any more than a small area, from collectively following a mean path approximating

to the selected axis of observation. Hence when the axes of the incident slit-beam and of the microscope are arranged, as in Fig. 24, only a small area of the posterior face of the corneal block will present itself to view by D.I.S.R., and, if we are working, as is usual in clinical work, with the illumination and observation axes lying in a horizontal plane, the area of the corneal surface— anterior or posterior—seen thus can only be one whose tangent-plane is vertical (Figs. 23 and 25). Hence, for purposes of viewing the corneal surfaces by D.I.S.R., the illuminating beam may just as well be cut down to the size and cross-section of a cylindrical beam of small diameter (Fig. 25).

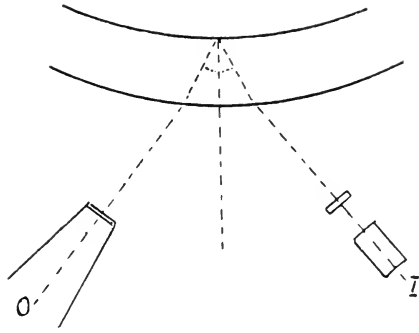

FIG. 24.—Observation of the endothelial face of the cornea by D.I.S.R.

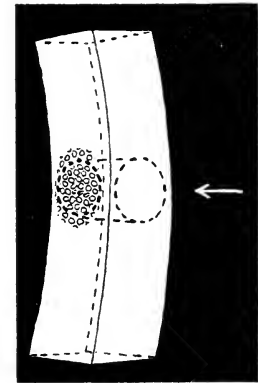

FIG. 25.—View of the endothelial face of the cornea by D.I.S.R.

Hence, for purposes of viewing the corneal surfaces by D.I.S.R., the illuminating beam may just as well be cut down to the size and cross-section of a cylindrical beam of small diameter (Fig. 25). It should be noted that a view through the Czapski microscope by D.I.S.R. cannot be binocular because the axis of the right and left portions of the microscope converge on the common point on which each focuses (Fig. 12). Thus if one side of the microscope be directed along the axis O (Fig. 20), the other side will lie along, say, O_1 ; so that whilst the first would yield a view by D.I.S.R., the second would reveal the same area simply by D.I. This fact can be put to use when it is desired to ascertain whether irregularities of contour of the reflecting surface are of the nature of elevations (convexities) or depressions (concavities). The direction of a reflected beam (nO , Fig. 26) off a specular surface (MR) is deflected (nO') in the direction of tilt (XY)

of the reflecting surface. Suppose we see by D.I.S.R. an abnormal picture of the corneal endothelial surface, such as Fig. 27, in which we can say of the dark patches that they are either areas which fail to give a specular reflex at all (*cp.* d, d, d, Fig. 19) or

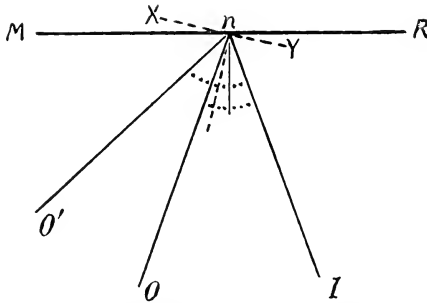

FIG. 26.—Alteration of the axis of specular reflection with varied tilt of the specular surface.

else areas which, though possessing reflecting properties, fail, from alteration of contour (*cp.* e, e, e, Fig. 19) to reflect the light along the same axis as the light reflected by the general endothelial surface. If they are the latter, glinting specular reflections will be seen off part of their contour if they are viewed, through one side of the microscope, at an angle which is not that of specular reflection for the whole field as seen through the other side of the microscope; consideration of the position of the glinting reflections and of the tilt of the axis of observation readily enables the observer to interpret whether the contour variations are of the nature of convexities or concavities.

To summarise, observation by D.I.S.R. is no more than observation by ordinary D.I. of any part of an anatomical optical face having mirror-like properties with the added condition that the chosen axis of the microscope focused on that part shall correspond with whatever direction at the moment constitutes the path of specular reflection of the illuminating beam.

A feature seen in the course of the thin optical sections of the cornea and the anterior and posterior lens-cortex may here be

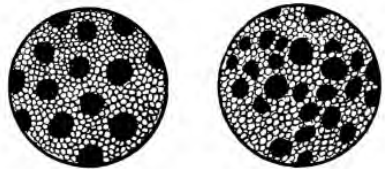

FIG. 27.—Views by D.I.S.R. of a corneal endothelial face in which areas of altered contour either are not reflecting along the mean axis of observation or are not reflecting at all.

referred to. When a very thin optical section of the cornea—more particularly of its peripheral region near the limbus—is approaching the angles at which the epithelial and the endothelial bounding edges will be seen by D.I.S.R., a change occurs in the appearance of the intra-corneal portion of the beam (Fig. 28) which lies between their specularly observed areas—it changes from its normal relucent grey-white appearance to a finely and vertically striated almost scintillating faint bronze or golden tinsel colour; this must presumably be due to a succession of multiple



FIG. 28.

Scintillating sheen in the optical section of the cornea.

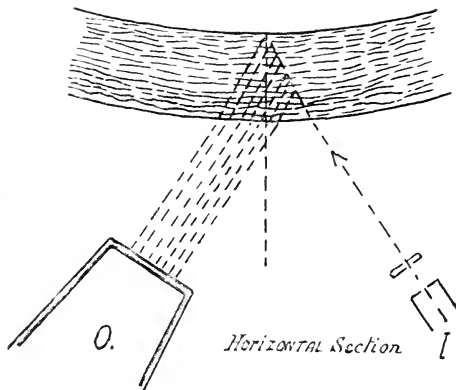

FIG. 29.

regular reflections of a sort occurring from the laminated structural principle on which the cornea is built (Fig. 29) (7). Under similar conditions, in the thin optical section of the lens-cortex, both anteriorly and posteriorly, particularly in elderly persons, an area (Fig. 30 X, X') comes to assume a metallic lustre, sometimes faint and golden, sometimes rich and copper-bronze. The explanation must be the same (Fig. 31) as in the case of the cornea—a summation of regular interior reflections due to meridional stratification of a medium which is not optically homogeneous (8).

The anatomical surfaces of discontinuity in the lens are each capable of causing regular reflection in very slight degree because their visibility in the thin optical section of the lens is best when

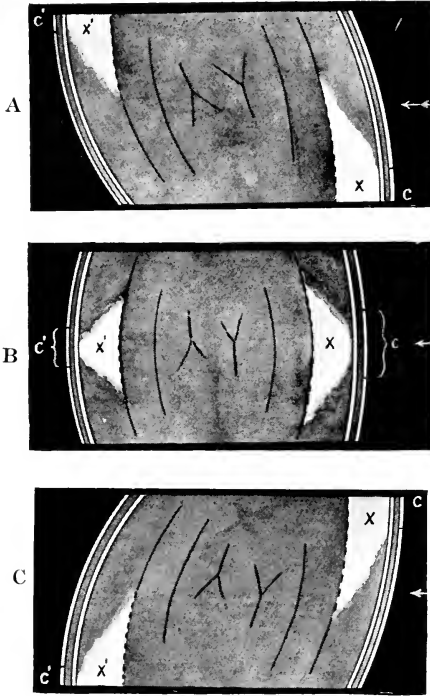

FIG. 30.

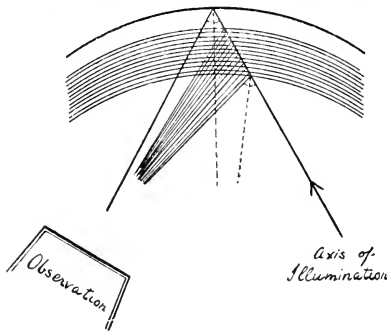

FIG. 31.

FIGS. 30 and 31.—Specular lustre in the lens-cortex seen in thin optical section.

the axes of illumination and observation make equal angles with the normal.

The term "Proximal Illumination" (P.I.) (10) is an appropriate one to apply to the displaying of features below the surface, and within the substance, of tissues which are translucent, but not transparent, in the way indicated in Fig. 32. In the anterior half of the normal eye this applies to the sclera, with its overlying tissue, and the iris; and in pathological eyes mainly to "opaque" lenses and to areas of inflammatory exudates.

Under the conditions of Fig. 32, if the iris be one whose stroma is not deeply pigmented its dark sphincter muscle, lying near the pupil, may often be seen when the beam is focused not on the sphincter, but into the stroma in the immediate proximity; similarly the blood vessels are often thus easily seen deep within a semi-opaque tissue.

A method of detecting abnormalities of or on the cornea—already referred to

as a factor contributing to the visibility of the K.P. in Fig. 5—by directing the light on to the white sclera at the edge of the cornea—can conveniently be classified as a form of proximal illumination; it can appropriately be called the method of “sclerotic scatter” (10). The light, focused in the region X (Figs. 33 and 34), is scattered by the white sclerotic tissue; some of it, entering the cornea meridionally rather than radially, passes right across the cornea, unable to make its escape because of successive interior reflections depending on the critical angle for the medium. Reaching the opposite side of the normal cornea it manifests itself in the sclerotic at the limbus, there forming a faint crescent of light (Y, Figs. 33 and 34; and Fig. 44A). If in its course across the cornea the light meets some abnormality such as the scar of an inflammatory focus or of a perforation, or if any part of one of the corneal surfaces is deprived of its optical individuality by adhesion to it of some

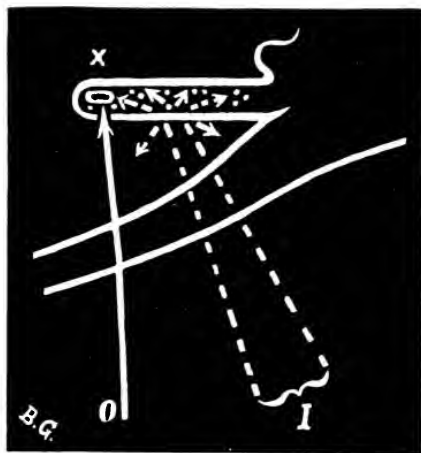

FIG. 32.—Proximal illumination.

scattering body whose refractive index is not materially different, then the light, escaping from the cornea, becomes visible. This principle is familiar in certain advertisement signs made out of plate glass through which light, unseen save where letters are engraved on the glass, is directed longitudinally. The method is appropriate only for naked-eye or low-power observation, but it is a very useful method for the preliminary detection of features.

To summarise, we thus have the following methods of illumination of transparent or translucent tissues (10) :—

D.I. : Direct illumination.

D.I.S.R. : Direct illumination with observation along the axis of specular reflection.

P.I. : Proximal illumination.

S.S. : Sclerotic scatter.

R.I. : Retroillumination.

Retroillumination has already been referred to (Figs. 5, 6 and 7),

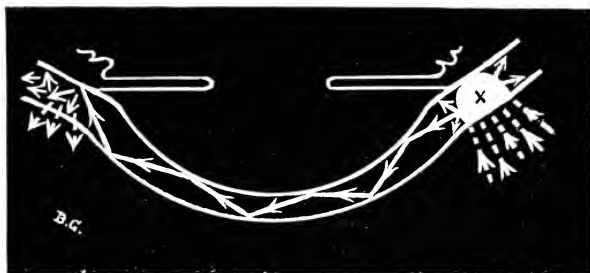

FIG. 33.

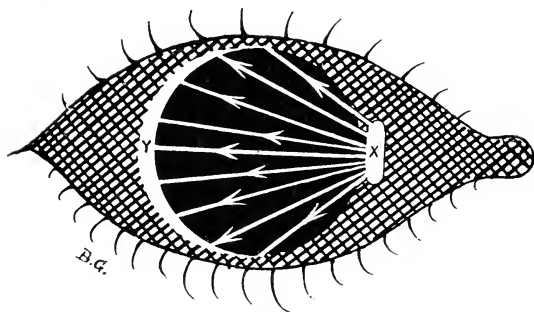

FIG. 34.

Figs. 33 and 34.—“Sclerotic scatter.”

and it remains only to add a few remarks about it. It not being possible to use a primary source of light for retroillumination of the living human eye (as could be done for the study of zoological tissue specimens), resource can be had only to a patch of light directed on to a demarcating surface (Figs. 41 and 45B) or to the visible passage of a beam of light directed through reluctant tissue behind the feature under observation, *e.g.*, a small vacuole in the anterior lens-cortex (Fig. 35) is readily seen against a small visible

beam traversing the lens-tissue behind it. Any arrangement of the illuminated background suffices to render visible a truly opaque feature like a lump of dark pigment set in transparent tissue, so long as it lies in the path between the observer's eye and the illuminated background; but many features which are visible, and visible either mainly or only, by retroillumination, are of the nature not so much of opacities as of sites of refractile disturbance of the tissue, *e.g.*, little vacuoles formed by discrete drops of fluid within the substance of the lens-cortex; or minute punctate nodules or excrescences on the deep face of the cornea. Retroillumination shows these up because each acts as a minute lens, and it is desirable to have a sharp contrast effect behind them—the meeting of light and darkness along a sharply defined margin; then the view of the margin, displaced by refraction as it is transmitted through,

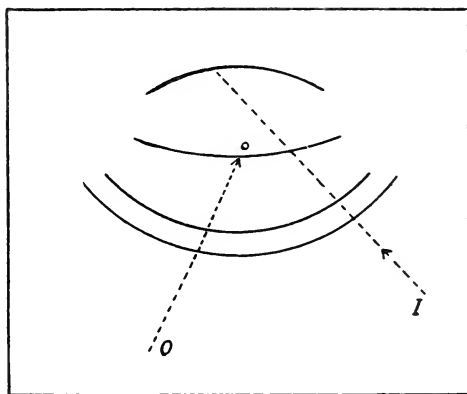

FIG. 35.—Vacuole in the anterior lens-cortex viewed by retroillumination.

say, the tiny vacuole, is seen in the vacuole geometrically out of line with the corresponding effect in the general illuminated background, as in Fig. 36, which shows vacuoles in the anterior lens-cortex viewed by R.I., against a sharply defined cylindrical beam of small diameter in the manner of Fig. 35. If the vertically extended slit-beam were used here instead, and the area of retroillumination were thus spread over a wider vertical area, the visibility of the vacuoles would be far less. In a similar way, vacuoles, invisible by direct illumination, are readily seen in the corneal epithelium by R.I. when the small circular beam is used (Fig. 37). Another source of retroillumination for the cornea is from a patch of light focused on the iris as

in I, Fig. 41. Thus Fig. 38 diagrammatically represents intraepithelial vacuoles of the cornea seen against a small circular beam-patch sharply focused on the iris.



FIG. 36.—Vacuoles in the anterior lens-cortex by retroillumination.

Fig. 39, A, represents correct, and B incorrect focusing for the R.I. patch on the iris. It will be noted that while the microscope is focused on the cornea the illumination is focused on the iris, and the latter must be sharply focused if to give

the required sharp margin to the retroillumination; the observer must accustom himself always to be adjusting the illumination focus, knowing that the patch of light itself is in focus when it is at its smallest. It often happens that pathological features in the cornea are readily visible by R.I. to a quite casual observer viewing the cornea opposite the illuminated pupil-edge, even though he does not trouble to use a small beam or to focus it correctly; this is because the pupil-edge (Fig. 40) itself affords the necessary sharp demarcation between light and dark visual background. Fig. 40 shows a disease of the cornea in which the deep face reveals permanent intrinsic changes of the nature of irregular and nodular thickenings. In an advanced stage of the affection the patient may proffer that he feels as if looking through corrugated or

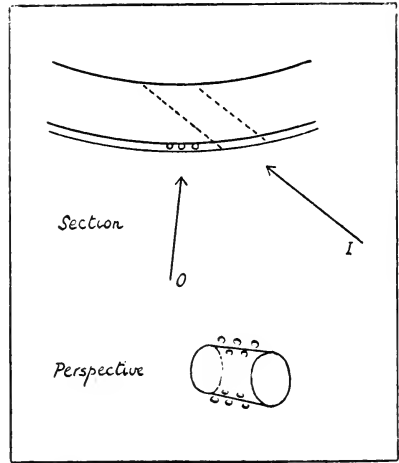

FIG. 37.—Intraepithelial corneal vacuoles seen with retroillumination by a small, sharp cylindrical beam traversing the substance of the cornea.

permanent intrinsic changes of the nature of irregular and nodular thickenings. In an advanced stage of the affection the patient may proffer that he feels as if looking through corrugated or

stippled glass. The diagram represents a fairly advanced stage of the disease in the centre of the cornea seen by D.I. in the corneal block, the deep face presenting by D.I. an appearance suggestive of the greyiness, the unevenness and the dull hueless lustre of the surface of pewter which has become partly corroded; more towards the periphery of the cornea the changes are less intense, taking the form of discrete punctate nodules which are very readily seen by R.I. against the patch of light on the iris bordering the pupil-edge. The illustration, which is diagrammatic, incorrectly shows the pupil-edge in visual focus which cannot be the case if the microscope is focused on the cornea, particularly with the objectives of higher power.

Fig. 21, C, corresponding with Fig. 22, d, d', shows how the specularly reflected beam from the posterior capsule of the lens may be utilised in retroillumination of the cornea.

It is not easy to interpret the nature of unknown pathological features seen by R.I.; thus, it is not possible to say by R.I. if the nodules seen in Fig. 40 are of the nature of convexities or concavities on the corneal face. (For this, recourse was had to the interpretation of the reflections off the rims of the nodules as described under Figs. 19 and 26 (10)).

Fine pathological features occur, more particularly of the cornea, which are visible only by retroillumination and not at all, or only indifferently, by direct illumination. In these cases it is not always easy to localise the depth; in the first place, the surrounding normal corneal tissue is invisible by retroillumination; and secondly, the pictures seen by the two eye-pieces, particularly with the high-power objectives, are not always alike, because the visual background is different for each (Fig. 41). Hence stereoscopic relief is

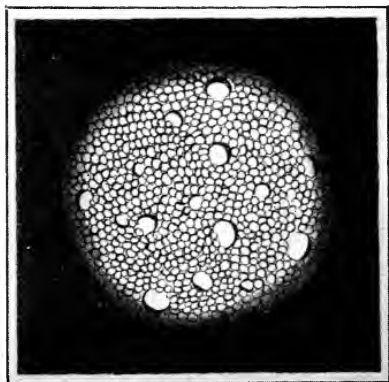

FIG. 38.—Intraepithelial vacuolation of the cornea by retroillumination.

not available for localisation, the observer's retinal disparation being too gross, though it may or may not play a part in revealing the mutual relationship of the multiple features to one another. The level of features seen in the cornea by retroillumination is best ascertained by the relationship to some chance feature on a surface visible at the same time, *e.g.*, a tear "bubble" on the epithelial surface, or a spot of pigment on the back of the cornea after senile detachment from the iris. One other means is available : to arrange a close angle of the illumination and observation axes and to endeavour to produce within the same field at the same time both a view by R.I. and also an illuminated pencil or D.I.

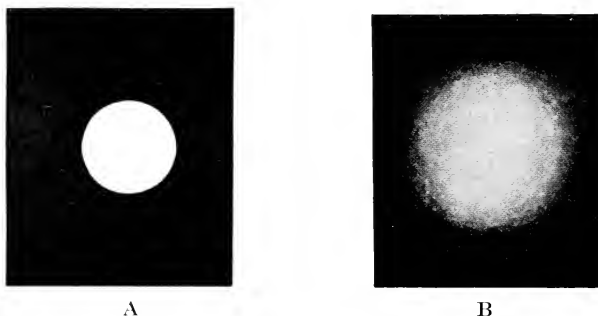

FIG. 39.—A, Correct and B, incorrect focusing of a patch of light for retroillumination.

"block" of the corneal tissue. Thus, in Fig. 42, the view d2, seen by retroillumination along O2, would be compared with the view d1 seen by direct illumination along O1. This method is more easily applicable near the periphery of the cornea where the iris is closer to it than is the case near the centre.

The term "opacity," which is properly defined as the ratio of the intensity of incident light to the intensity of light transmitted, has been partly misused in ophthalmology, as when we focus a light by ordinary "oblique" illumination direct upon an area of pathological change in, *e.g.*, the cornea or lens, and, judging from its visibility as it is thus seen by direct illumination, we call the area an "opacity." To make a simple comparison ; a splash of dark pigment on the anterior lens-capsule, in the direct course of

the entering slit-beam, is by no means so readily visible as a small white-looking "lens-opacity" thus vividly illuminated; yet the pigment may be for all practical purposes completely obstructive to the passage of light and the "opacity" often but slightly so. Certain forms of fluffy white "lens-opacities," whose visibility is very bright indeed under the direct illumination of the slit-lamp, scarcely show to any marked extent by the transmitted light of

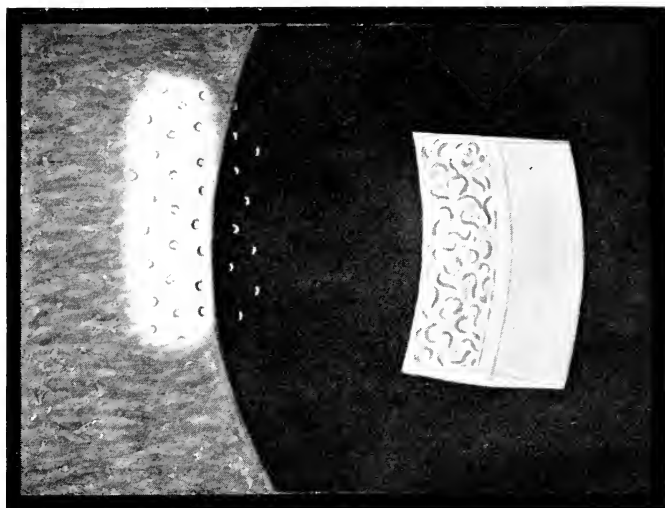

FIG. 40.—A bilateral chronic affection of the endothelial face of the cornea of elderly persons.

retroillumination. It is a common fault for beginners to look upon tissue-areas (*e.g.*, the zones of disjunction of the lens) which may be more relucient than the surrounding tissue (the general lens-substance) as being more "opaque." The normal cornea by D.I. is very relucient; but it is not opaque. An ideally transparent medium has unit opacity of which the density, the logarithm of the opacity, is zero. Because in the optical section certain features may appear vividly white, *i.e.*, very visible, very relucient, it is inaccurate to say that they are very "opaque"; the word opacity should not be used, scientifically, for features whose optical density

borders on zero. Neither the relucency nor the specularly reflecting property of a tissue is to be taken clinically as a measure of its capacity to obstruct the passage of light; the term opacity should be concerned only with retroillumination and not with direct illumination.

It has seemed appropriate, for this book, to confine the account

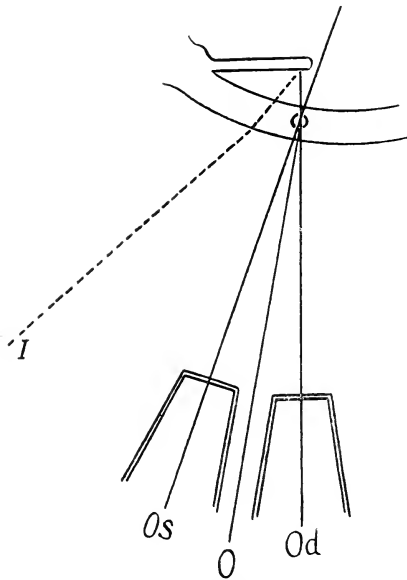

FIG. 41.—Retroillumination: dissimilarity of binocular images when under high magnification.

of Microscopy of the Living Eye mainly to technique, partly because the principles are quite probably applicable in other useful fields, *e.g.*, zoological work; and also because in the space available a comprehensive account of common normal and pathological clinical features could not well be given. For this, reference should be made to other publications (*e.g.*, 1, 2, 3, 4, 5). However, it may be appropriate to conclude with some remarks bearing on the clinical application of the subject, illustrated by a few examples of clinical conditions.

In 1911, at the Heidelberg Ophthalmological Congress, Gullstrand showed his slit-lamp which was combined later for use with the Czapski binocular microscope. The slit-lamp then had two outstanding defects by comparison with the models which were evolved later: the focusing-lens was not achromatic, and the optical system furnished a focal beam of relatively insufficient intensity. Vogt, of Basle (later of Zurich), in co-operation with the late Dr. Henker, director of the Medical Optical Department of Carl Zeiss, modified the apparatus, taking advantage of the

opportunity offered by the commercial improvement in the manufacture and design of small electric filament-lamps of high intensity. In the years 1915 to 1919 Vogt published in German various communications on his clinical slit-lamp findings, his work of these preceding years at Basle culminating in the publication of his Atlas (5) in German in 1921, von der Heydt's English translation of which appeared soon after in America. At this date the various countries that had been involved in the distraction of the War were only just beginning to turn their attention to new and constructive work, and their ophthalmologists began to learn of to them an almost new subject at a time when it had already attained considerable development in the hands of Vogt in Switzerland. Koeppe, of Halle, also did much work on the subject (3). Vogt's "Atlas" contained very little on the subject of technique and in the two or three years succeeding 1920 independent workers evolved for themselves the subject of technique, and published many observations of their own, further impetus being given to the subject by a summer demonstration which was given by Vogt, in Zurich, in 1923 and again 1924. By now the writers on the subject in various countries were becoming numerous and whilst many published observations which they not unnaturally assumed to be original subsequent reference often enough showed previous evidence of similar findings by Vogt in his publications of 1915 to 1919. Vogt had in these years for ever laid the clinical foundations of this work. Later, in other countries, the names of different observers became, in their own country, associated with

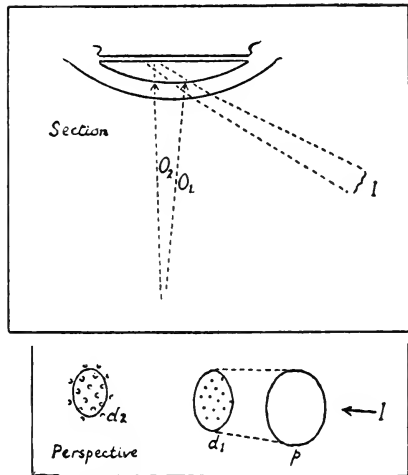

FIG. 42.—Simultaneous comparison of views by retroillumination and direct illumination for localisation in depth.

an active interest in the subject : in the United States of America, Bedell, of Albany, devoted much attention to it and, with von der Heydt of Chicago who translated Vogt's Atlas, was mainly responsible for introducing the subject into that country ; in England, the work of Harrison Butler, of Birmingham, stimulated the interest of ophthalmologists in the subject ; in Belgium, Gallemaerts ; etc.

Although nowadays there are various makes of slit-lamp apparatus for the clinical examination of the eye, up to comparatively recently the one in general use has always been that of Zeiss, and it is interesting to note how an apparently small omission, viz., to equip all the instruments with the improved achromatic focusing lens, was much responsible for the rather retarded adoption of the apparatus in the countries to which it was exported. I cannot speak for other countries than England and the U.S.A., but as late as the end of 1923, in England, the Zeiss slit-lamp was being supplied fitted only with the old Gullstrand focusing-lens which was not achromatic, and in the case of the U.S.A. this applied up to 1925. Another commercial error as regards the countries to which it was exported was the supplying of the slit-lamp so made that it could be combined for use alternatively with the simplified Gullstrand ophthalmoscope, the resulting slit-lamp being quite unsuitable for proper slit-lamp microscopy of the eye : the temptation to secure two pieces of apparatus in one led many or most to buy what was unsuitable.

The term "Biomicroscopy" has appropriately been proposed (13) by Dr. Edward Jackson, though it may be suggested that the use of the term microscopy was, perhaps, partly responsible in early years for opinions that existed adverse to the alleged clinical usefulness of the apparatus. It was not sufficiently appreciated, and sometimes is not now, that the pictorial effects are more anatomical than histological—at any rate, where examination of the living eye is concerned—one of the great advantages being that the slit-lamp has brought to light the usefulness of the Czapski binocular microscope. This instrument, little used hitherto, had existed in almost its present form for many years

before the slit-lamp was devised. The range of magnifications usefully appropriate in slit-lamp examination of the living human eye may be said to be approximately from $\times 9$ to $\times 45$. Clearly, higher magnification is easily possible in other forms of biological work, dependent on the limitations imposed by the intensity of the source of the slit-lamp light, and by the mobility of the object, and by the depth from its surface to the plane under observation. The beginner in clinical examination of the human eye usually makes the mistake of seeking for usefulness in a high magnification, forgetting that he is thereby limiting himself in focal depth as well as in square dimensions. The endothelial cells in the single layer lining the back of the cornea are just visible as such, by examination of this plane in the axis of its specular reflection, with the $\times 9$ magnification (Fig. 25). Variation of the magnification is effected by the usual variable combination of oculars and objectives, the standard apparatus being provided with two pairs of oculars and three paired objectives; for ordinary practical clinical work it suffices to possess one pair of oculars and two paired objectives, affording a $\times 9$ magnification—which just includes the whole cornea within the field of observation—and a $\times 24$ magnification.

The examination of the lids and conjunctiva presents little or no difficulty. By proximal illumination the blood-corpuseles can be seen circulating in the conjunctival vessels. Sometimes an optical section helps in distinguishing the nature of a cystic swelling of the conjunctiva, *e.g.*, an epithelial implantation or a lymphatic cyst, by revealing the presence or absence of septa within. The rather rare condition of a pigmented mole of the bulbar conjunctiva, close to the limbus (Fig. 43), has a very typical slit-lamp appearance due to the enclosed crypt-like spaces lined by stratified epithelium which are characteristic of this form of overgrowth (7); these spaces appear by proximal illumination as multiple dark areas throughout the substance and are far more characteristic than the presence of pigment whose quantity may be so small that it is scarcely detectable clinically. In the very rare instance of this type of overgrowth occurring in the part of the bulbar conjunctiva beneath the upper lid the prolonged lid-

pressure leads to modification, including vascular disturbance, in the appearance of the tumour, but its nature is disclosed with certainty by the contained multiple dark crypt-like spaces.

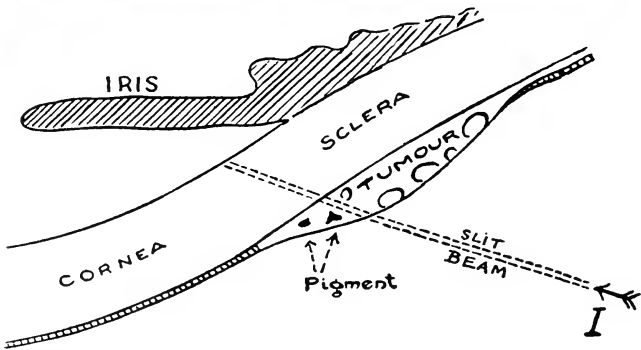
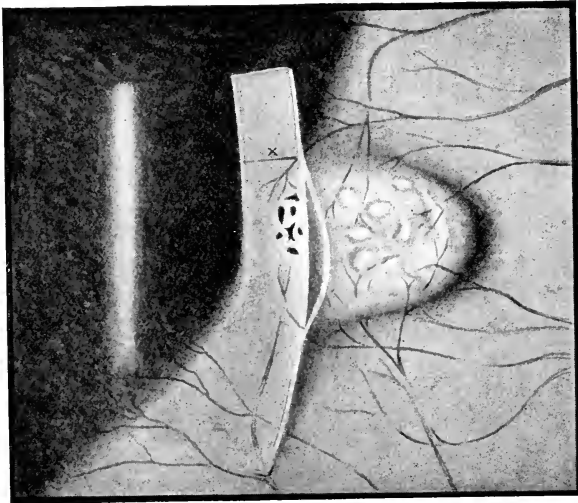

FIG. 43.—Innocent melanoma, or pigmented mole of the limbus.

The study of the normal cornea reveals its anatomical shape in the optical section which is uniformly relucant from front to back, except for a slight normal intensification at the front and

back corneal surfaces. Descemet's membrane is optically continuous with, and is indistinguishable from, the substance anterior to it. The dichotomously branching normal nerve-fibres are readily visible in the optical section of the cornea. Reference has already been made (Fig. 25) to the visibility of the lining endothelial cells when the posterior surface is viewed in the axis of specular reflection. If the anterior surface is viewed in the axis of specular reflection no cell-structure is visible, the surface acting as a mirror being in this case the covering layer of tear-fluid; moreover, the cellular layer on the anterior surface is multiple. Near and at the limbus the epithelial surface line becomes very slightly raised from the underlying transparent fibrous tissue, by the intervention of a narrow optical gap, so that it is discrete (4, Fig. 3). The most superficial vessels which spread over the cornea in the condition of "pannus" lie in the plane of this gap. On the peripheral side of the limbus, *i.e.*, over the sclera, this gap is widened by the presence of the lax areolar tissue which lies between the epithelium and the sclera throughout the bulbar conjunctiva.

Reference has been made to the internal illumination of the cornea faintly but clearly against a dark background by the simple means of "sclerotic scatter" (Figs. 33 and 34). In Fig. 44. A shows the detection of a small nebula (at 2) of the cornea, the beam of light being focused on to the sclera near the limbus (at 1); (3) is the crescent of light in the sclerotic diametrically opposite the region of impact of the beam and after it has passed across the cornea. The region of the nebula itself is shown in B, under higher magnification in the direct illumination of the wide slit-beam. The nebula is a superficial one and bears with it vessels continuous with the conjunctival vessels. Under still higher magnification in C, the plane of these superficial vessels is seen by direct illumination (1) at its true level in the proximal lateral face of the block, other vessels of the same group being visible by retroillumination (2) against the light-patch on the iris behind. The plane of the main cellular infiltration which is giving rise to this nebula is finally defined with exactness in the thin optical section D.

True flattening of part of the corneal face following injury or disease is possible, but rare. Not infrequently nebulae or scars deep to the surface will simulate flattening of the surface when examined with the wide slit-beam, as shown diagrammatically in Fig. 18, A; but when they are examined in the thin optical

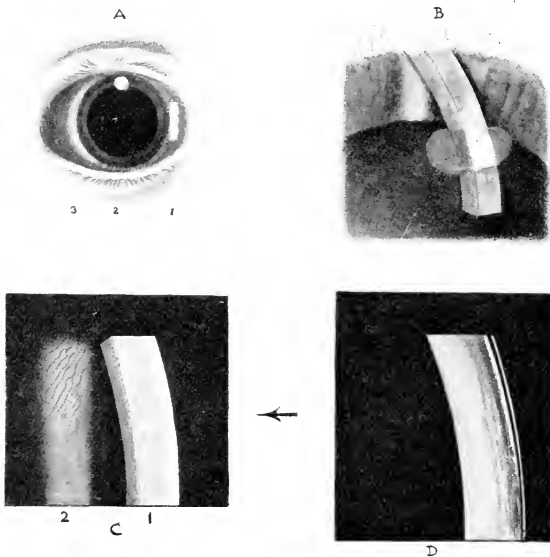

FIG. 44.—A, Superficial nebula of the cornea revealed by “sclerotic scatter.” B, The nebula by direct illumination. C, The pathological vessels in the nebula by direct illumination and retroillumination. D, Thin optical section of the cornea in the region of the nebulous infiltration. (*Drawn by Theodore Hamblin, Ltd.*)

section (Fig. 18, B) the surface contour of the cornea is seen to be normal.

Localised bullæ or blebs of the corneal surface caused by fluid-elevation of the epithelium show by direct-illumination in the thin optical section as in Fig. 18, C; they are also revealed clearly by retroillumination.

A permanent superficial scar of the anterior corneal surface due to a grazing blow from a missile, is shown in Fig. 45, A; in

this case the optical properties of the scar are such as to give rise to a pictorial reproduction of its image at the posterior corneal face of the block of light. It can be understood how an observer, studying only the posterior face within a restricted field under a high magnification of, say, $\times 35$ or more, could misinterpret such an optical effect as being a pathological condition at the posterior face; this mistake is particularly apt to be made by the beginner when the false appearance is caused by minute bullæ of the epithelium of the anterior face whose shadows may make ring-like markings at the posterior face (see Fig. 46, C). This deeper optical

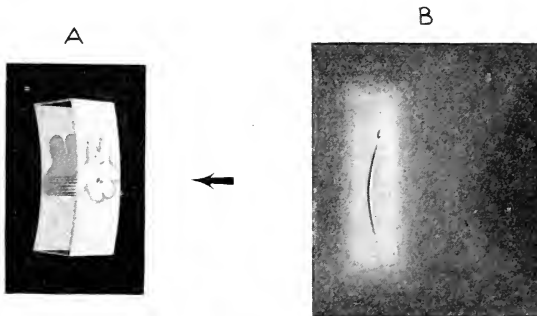

FIG. 45.—A, Scar of the anterior corneal face following injury. B, Scar of the posterior corneal face following surgical penetration. (*Drawn by Theodore Hamblin, Ltd.*)

modification of the corneal beam by surface features sometimes makes it difficult to distinguish the exact depth to which a perforating injury, or its resulting scar, extends. Accidental perforations of the cornea nearly always leave for the rest of life a scar detectable by slit-lamp examination. Clean deliberate minute surgical penetrations often leave little or no evidence of their course through the epithelium and the substance of the cornea, whose cells regenerate to bridge the gap; but every surgical penetration which is complete and goes through the posterior face leaves a permanent indication at this face, because the hyaline material which is afterwards secreted by the endothelial cells to fill the gap in Descemet's membrane is never in regular

continuity with the plane of the posterior surface. Fig. 45, B, shows by retroillumination a very characteristic scar of the posterior face due to the former perforation by a tangentially disposed broad spear-like surgical needle.

Precipitates ("K.P.") on the posterior face of the cornea are

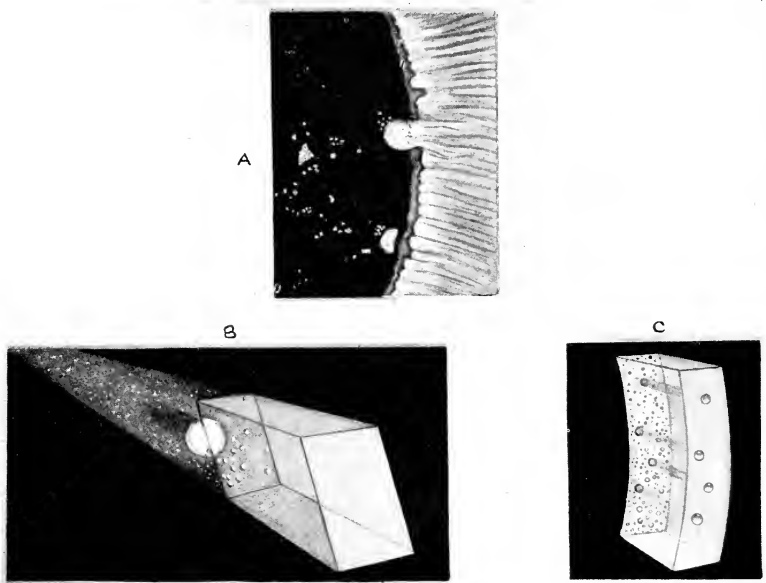

FIG. 46.—A, inflammatory "nodules" at the pupillary border, and deposits on the anterior lens-capsule. B, "K.P.," also pathologically increased relucency of the aqueous fluid which contains numerous products of inflammation. C, Pathological markings of the posterior corneal surface, and shadow-streaks from droplets on the anterior surface. (Drawn by Theodore Hamblin, Ltd.)

shown by direct illumination in Fig. 46, B, having been deposited from the aqueous fluid in inflammation of the iris and ciliary body. If the slit-lamp were used for no other purpose than the clinical detection of "K.P.," its possession and efficient use by every practising oculist would be justified: these fine precipitates on the back of the cornea may be, and often are, the only feature distinguishing intraocular from extraocular disease in those mild

cases of slightly inflamed "red" eyes, about the nature of whose condition there may be doubt; and they may sometimes be found, in very small degree, in eyes which otherwise have revealed nothing suggestive of any organic affection. Very little experience enables an observer to distinguish between "K.P." in its various forms, and other abnormalities due, *e.g.*, to actual changes of the posterior surface, an example of which may be seen in Fig. 40 and Fig. 46, C. Fig. 46, B, illustrates a beam of almost square cross-section, formed by cutting down the vertical diameter of the slit, illuminating a large spot of "mutton fat" K.P., of the type seen in those cases of cyclitis which are often somewhat loosely styled tuberculous because many improve on empirical treatment with tuberculin. The long-continued presence of such massive precipitates may exert some influence on the overlying and adjacent epithelial surface so that it displays fine vacuolation (9). Some fine precipitates are also depicted in Fig. 46, B; often K.P. may take the form of only very fine dust-like particles. The importance of slit-lamp examination for the presence of fine K.P. in suspected sympathetic disease of the sound eye following injury to the other eye, cannot be overestimated (16).

Fig. 46, C, represents the appearance of the posterior corneal face in an earlier stage of the disease in elderly people previously referred to under Fig. 40. Only a beginner could mistake these markings for precipitates on the back face of the cornea. The four bullous or ring-like markings on the anterior face depict droplets of oil such as may be seen if an oily solution of a drug has been used on the cornea; the illustration would equally serve for pathological elevations or bullæ of the epithelium of the anterior face of the cornea. The shadow-streaks in the beam and the optical simulation at the deep face will be noted.

The onward course of the beam in Fig. 46, B, is readily visible through an aqueous fluid whose relucency is pathologically increased by colloid and cellular products of inflammation. The discrete particles visible in such an aqueous fluid are usually not individual cells, but clumps of cells—white or red blood cells, or pigment cells detached from the uveal layer. The normal aqueous fluid has slight relucency, which is not usually visible with the

slit-beam, but is visible when a round beam of small diameter is used owing to contrast with the surrounding unilluminated area (Fig. 47). Naturally this visibility will vary with the intensity of the initial source of light, being greater when an arc-lamp slit-lamp is used. The observer who wishes to judge between normal and pathological relucency of the aqueous fluid must accustom himself to the particular apparatus he uses. Certain careful

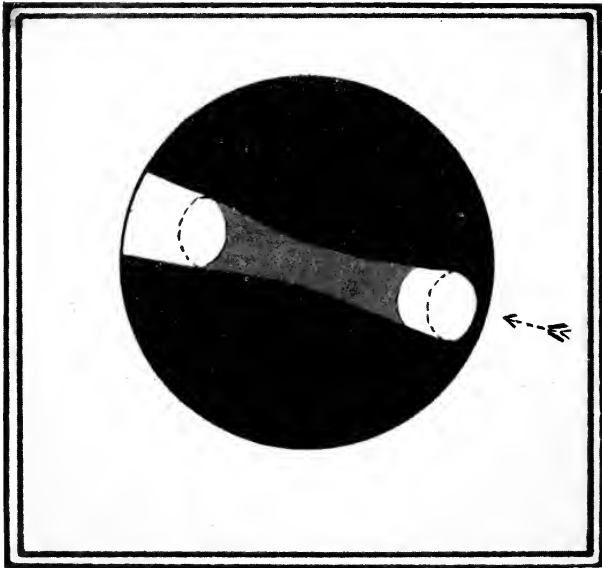

FIG. 47.—Cylindrical beam traversing the aqueous fluid between cornea and lens.

adjustments are needed in order to avoid possible fallacies (11 and 18).

When discrete particles are present in the aqueous fluid their movement discloses the convection-currents in the fluid, being downwards in the anterior part where the fluid nearer the surface is cooler and upwards in the deeper posterior regions. Fig. 46, A, shows pigmented and unpigmented cellular and amorphous precipitates on the anterior capsule of the lens, and, on the pupillary border of the iris, two very characteristic nodular excrescences,

one emerging through the pigment layer posteriorly and one through the stroma anteriorly. These last should not be called tubercles, but nodules, because they are seldom of tubercular origin; they occur mostly in an unobtrusive, but very chronic and persistent form of iridocyclitis of varying or uncertain aetiology.

The iris is readily accessible to slit-lamp examination; Fig. 48 shows a striking view of a small angio-sarcoma of the iris in process



FIG. 48.—Small malignant highly vascular tumour of the iris, with bleeding taking place from crypt-like cavities.

of bleeding into the aqueous fluid, the patient having given the history that on three or four occasions in the preceding two or three years she had “seen red” with this eye whose sight was otherwise normal.

Care is required to obtain clear optical sections of the living lens, owing to the distance separating the anterior and posterior surfaces: a sharp section of both regions at the same time is usually not obtainable, this particularly being the case when the 7.0 cm. focusing lens is used (see Fig. 11). It is, however, usual in

diagrams to represent the sharp optical section of the lens as being in simultaneous focus from front to back. The normal curves of the two surfaces of the lens are shown in Fig. 50, C.

Observations of alteration of shape of the lens in the act of accommodation are not favourable in the optical section of the normal lens, owing to the wide distance separating the anterior and posterior surfaces; but a unique case in which a microscopic injury had led to complete solution and disappearance of the entire contents of the capsule afforded, by no other means than slit-lamp

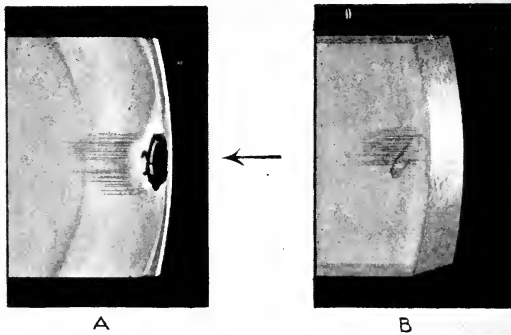

FIG. 49.—Wide slit-beam (B) and narrow slit-beam (A) through anterior region of the lens showing pathological dissolution of a small area of the cortex.

(Drawing by Theodore Hamblin, Ltd.)

investigation, very precise and conclusive evidence of the alteration of the tension of the capsule during the act of accommodation and under the influence of various drugs (17).

Slight disturbances in the optical section of the lens are very common in elderly people. Examples of this are shown in Fig. 49; in B the wide beam is used, and the disturbance in the anterior cortex is evident, whilst in A the same region is shown in thin optical section. The optical shadow-streaks passing back from the disturbed area will be noted. In B the anterior lens capsule, throughout a large area of its illuminated face, is seen in the axis of its specular reflection and reveals the "shagreen" appearance seen when (and only when) the capsule is thus viewed. In many

pathological states of the underlying cortex this "shagreen" lustre acquires iridescent-like colourings. More intense and more obstructive zone-like changes are shown in the deep cortex, both anterior and posterior, in Fig. 50, C. What in this picture might appear to be an extension into the vitreous is in reality only that portion of the zone-like change which is faintly illuminated by lateral scatter of light in it beyond the confines of the optical section and is viewed by retroillumination against the posterior end of the section.

The slit-lamp makes it possible to study, in their early state, minute changes in the lens more easily than heretofore. Any individual, from the age of about forty-five, is apt to show minute lens-changes, forerunners perhaps of truly senile processes not due for yet another two or three decades and of little more significance from the point of view of "decay" than is the occurrence of a few grey hairs on the head. But all too often the patient

is told of these small changes, or what is more likely he, or circumstance, forces an admission as to their presence; from this it is but a short step in the patient's mind to the significance of the term "cataract." Up to the present time there is no scientifically proved specific means of arresting these minute physiologically retrogressive changes—when they are purely senescent and are not

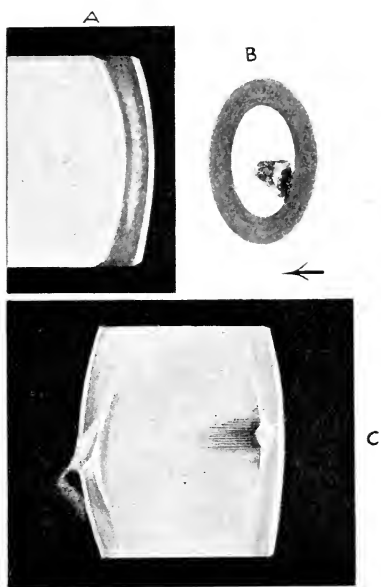

FIG. 50.—A, Slit-beam showing a plaque-like change in the anterior lens-cortex. B, The same viewed as an opacity by the ophthalmoscope. C, Pathological changes in the anterior and posterior lens-cortex.

(Drawing by Theodore Hamblin, Ltd.)

due to local disease in other parts of the eye—and it is reasonable to assume that probably none will be found for some time yet to come. No matter what advantages have accrued in the past and will accrue in the future from rational research, certain apprehensive elderly patients will always criticise, some will even feel resentment towards any profession which, concerned with healing, cannot confer somatic immortality. The more vigorous has been the patient's vitality, or the greater his attainments in life, often as not the higher his social status, then the more independently and indomitably will he be likely to resent accepting defeat in decline, and so will turn to any "treatment" that is accompanied by some plausible ritual—be it bathing the eyes with lemon-juice, gazing at coloured fetiches or what not—hopefully offered as warding off the dreaded condition of "cataract." This is digression: it is only to urge avoidance of the misguided use of the word "cataract" (14) in relation to minute lens-changes, which, often practically invisible by retroillumination, would commonly enough not materially alter for, it may be, twenty or thirty years, even when nothing at all is done; yet which, to the mind of an apprehensive and impressionable patient submitting himself to some faith cure, may afford a wonderful example of a skilled remedy for a condition which did not materially exist.

Of much more clinical significance may be the discrimination of lens-changes which are secondary to such other eye-affections as cyclitis, choroiditis, etc., and also the study of the effects of perforating and concussion-injury to the lens.

One interesting class of concussion-injury may be mentioned. Fig. 50, B, shows the ophthalmoscopic appearance of a zone-like opacity in the anterior lens-cortex caused by a previous concussion-injury. In Fig. 50, A, its level is defined in the slit-beam between the capsular and the adult nuclear face. The injury in this case was sustained seven years previously in the immediate subcapsular region; the persisting opacity which resulted has relatively migrated gradually away from the subcapsular region with the combined growth of new lens-matter beneath the capsule and the gradual shrinkage of the older lens-matter nearer the centre. This is a gross and obvious case; but it sometimes happens that

concussion-injury to the eye produces at the time a scarcely detectable influence on what is presumably the most vulnerable part of the lens, viz., the newest formed subcapsular fibres. As the years go by this particular layer migrates deeper and deeper, and though in mild cases its transparency is not diminished and it is therefore invisible by any form of retroillumination, it has been optically modified permanently in some way so that it scatters the light, appearing in the thin optical section as a clear relucient curved line nearly concentric with the lens capsule from which it has become separated. In other words, concussion injury to the eye can permanently affect a very thin layer, giving it increased relucency, detectable by no other means than direct illumination in a slit-lamp optical section; and the level of the zone, *i.e.*, its depth from the capsule, affords a very precise indication of the relative time that has elapsed since the receipt of the blow which caused it (15). The condition is not illustrated here; its appearance is not unlike, but very much fainter than, that of the thin curved lines in the cortex of Fig. 50, C, with the omission of the coarser, thicker regions of change drawn there.

The normal vitreous fluid shows a gossamer-like fibrillar or reticular optical appearance whose constituents sway and oscillate with movement of the eye. This appearance is usually absent for a short distance immediately behind the posterior lens-capsule, the retrolental region being a relatively non-relucient space which presumably contains aqueous fluid (see R, Fig. 1). In some inflammatory conditions of the interior of the eye this fibrillar mesh-work gains definite adhesion to the face of the posterior lens-capsule. Inflammatory and degenerative products may appear in the vitreous, sometimes in gross form, *e.g.*, ball-like masses of cholesterin crystals. If these are examined in the slit-beam with low ocular magnification they appear somewhat as in Fig. 51, A; but if high magnification is used they appear somewhat as in B, a false impression of exaggerated size tending to be conveyed by those of the illuminated clumps which are not in the immediate focal plane of the microscope, which in this drawing is supposed to be just immediately behind the posterior lens-capsule.

The illustrations which are the subject of this article have been

chosen to convey a fairly representative idea of the general scope of slit-lamp examination of the living eye. I am indebted to the Ophthalmological Society of the United Kingdom and to the Editors of the *British Journal of Ophthalmology* for permission to reproduce some of the figures which have accompanied communications previously published as quoted in the references below. Figs. 44, 45, 46, 48, 49 and 50 have been kindly drawn for me by Messrs. Theodore Hamblin, Ltd., from my own clinical cases, except the case of Fig. 48, which is of a patient who was under the consecutive care of Mr. Ransom Pickard and of Mr.

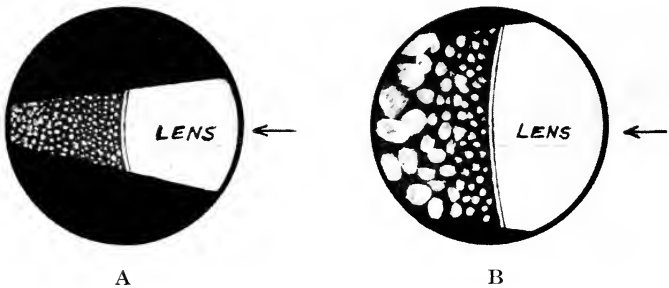

FIG. 51.—Pathological masses in the vitreous fluid seen by (A) low and (B) high magnification.

Foster Moore and to whom I had access when she was in Moorfields Eye Hospital: it is here made use of with their kind permission. I am indebted to Messrs. Carl Zeiss for Figs. 8, 9 and 12.

Some of the pictorial living processes seen so strikingly in slit-lamp microscopy of the living eye, such as the pupil-contractions, the circulation of the blood-cells in vessels, their inflammatory exudation and deposit, and many other features, might well be made a subject of demonstration in the curriculum of all medical students.

REFERENCES

1. BUTLER. "An Illustrated Guide to the Slit-lamp," 1927.
2. KOPY. "Slit-lamp Microscopy of the Living Eye," 2nd Edition. Translated Goulden and Harris, London, 1930.
3. KOEPPE. "Die Mikroskopie des lebenden Auges," Berlin, 1920, 1922. Cf. *Ar. f. Ophth.*, 1917, *et seq.*

4. MEESMANN. "Die Mikroskopie des lebenden Auges an der Gullstrand'schen Spaltlampe mit Atlas typischer Befunde," 1927.
5. VOGT. "Atlas der Spaltlampenmikroskopie des lebenden Auges." Berlin, 1921.
6. GRAVES. "Microscopy of the Living Eye." *Transactions of the Ophthalmological Society of the United Kingdom*, Vol. 43, 1923.
7. "The Slit-lamp and the Histological Appearances of a Small Tumour at the Limbus." *Transactions of the Ophthalmological Society of the United Kingdom*, Vol. 44, 1924.
8. "Microscopy of the Living Eye." *Brit. Med. Journ.*, October 25th, 1924.
9. "Reports to the Lang Clinical Research Committee—Microscopy of the Living Eye." *British Journal of Ophthalmology*, October, 1924.
10. "Reports to the Lang Clinical Research Committee—A Bilateral Chronic Affection of the Endothelial Face of the Cornea of Elderly Persons." *British Journal of Ophthalmology*, November, 1924.
11. "The Outstanding Beam of the Aqueous Fluid." *American Journal of Ophthalmology*, January, 1925.
12. "Slit-lamp Apparatus." *American Journal of Ophthalmology*, February, 1925.
13. *American Journal of Ophthalmology*, 250, March, 1925 and 975, December, 1925.
14. "Slit-lamp Examination of the Lens." *American Journal of Ophthalmology*, August, 1925.
15. "Injury to Lens Detected only by Slit-lamp Observation." *American Journal of Ophthalmology*, 904, November, 1925.
16. "Some Suggested Lines of Clinical Research." *American Archives of Ophthalmology*, Vol. 55, No. 4, 1926.
17. "Change of Tension on the Lens Capsules during Accommodation and under the Influence of Various Drugs." *Transactions of the American Ophthalmological Society*, 1925, and *Brit. Med. Journ.*, January, 1926.
18. "The Anterior Chamber, Aqueous Fluid and Iris." *Transactions of the Ophthalmological Society of the United Kingdom*, Vol. 45, 1925, p. 683.

Section III

ZOOLOGY

By **E. W. MACBRIDE**, LL.D., D.Sc., F.R.S., etc.,
Professor of Zoology, University of London, Imperial College of
Science and Technology, S. Kensington,

and **H. R. HEWER**, A.R.C.S., D.I.C., M.Sc.
Lecturer in Zoology, Imperial College of Science and Technology,
S. Kensington.

INTRODUCTORY

THE last ten years, and more particularly the last five, have seen a very important change in the study of the minute structure of the animal cell. In order to appreciate this fully it is necessary to recapitulate briefly the earlier work.

With the rediscovery of the elementary laws of Mendelian inheritance at the beginning of the century, the previously described nuclear changes acquired considerable significance. Not only the influence of the Weissmanian germ plasm theory, but also the knowledge that the main (if not only) part of the sperm incorporated in the zygote was the nucleus, induced cytologists to concentrate upon the nucleus in looking for the material basis of inheritance. When the remarkable parallelism between the behaviour of the chromosomes in the maturation divisions and the segregation of the factors assumed by the Mendelists was realised in broad outline, it became the aim and purpose of cytologists to establish the identity of chromosomal material with these factors.

The result of this was to concentrate attention almost entirely on the nucleus, and at the same time to reduce the cytologist to the position of an assistant to the geneticist. It was the function of the cytologist to provide the material phenomena upon which the geneticist could build his theories. As genetical research

continued to find peculiar and exceptional phenomena necessitating modifications and additions to the previous theories, so cytologists attempted to find their equivalents in cell structure and behaviour. Thus arose the peculiar position in which genetic theory outran cytological observation even to the limit of the resolving power of the microscope.

Once the universality of the ordered methods of nuclear division, known as mitosis and meiosis, was established in all the main groups of animals in which genetic investigation had shown the Mendelian laws to operate, the cytologist's work in this field was practically at a close. Not that many outstanding problems did not remain, but, as subsequent work has shown, the physical limitations of microscopical technique were too great and the geneticist has had to proceed on assumptions. The classical example of this is, of course, "crossing over," which has never been actually demonstrated cytologically, although a period has been described in which it could occur.

The present trend of cytology has arisen, too, from studies originally pursued in other sciences. The rise of the hormone theory and the importance of enzymes in relation to both sexual and general physiological phenomena has stimulated investigations into the structure and function of the various components of the cell other than the nucleus. Thus most of the recent work centres around the activities of the Golgi apparatus, mitochondria, the phenomena of secretion, absorption of food and other activities of the normal cell. It will be noticed, too, that although much of the pioneer work in this direction was carried out on germ cells, whose rhythm, function and ultimate fate were fairly well known, attention is now given to many of the other cells of the animal body.

It is of course true that this tendency began more than ten years ago, but much of this earlier work was isolated and uncorrelated and suffered in confusion as much from the want of workers as from the lack of knowledge. The very considerable progress made recently is chiefly due to improved technique. This has occurred not only in improvements in method made possible by advances in biochemistry and their application as microchemical methods, but also in a general onslaught made upon

the cell organs so that rapidly the homologies of permanent constituents of the cell could be agreed upon and definite standard tests of structure and behaviour fixed.

It would be impossible at this point to omit mentioning the advent of two valuable instruments which have come into the hands of the animal microscopist. Firstly, the perfection of an instrument for micro-dissection by means of which living cells and organisms can be manipulated has relieved the microscopist of the temptation to guess at the physical nature of the cell constituents. Paraffin sections and smear preparations are no longer the only means by which he can examine cells. A very considerable body of evidence has been collected by this means, so that the physical picture which a cytologist should call up in his mind of the cell structures need no longer be based on staining and fixing capacity of the particular structure or the technique applied. In this direction investigation has only just started and much more is to be expected from it.

Secondly, the technique of tissue cultivation *in vitro* has contributed much to the microscopist's power. The growth of tissue in a layer one cell thick has made it possible to follow cell behaviour continuously instead of by a series of pictures compiled from sections and arranged in (possibly) the right order. Both this and the preceding technique suffer from limitations chiefly optical in nature, but the use of the ultramicroscope opens up possibilities which have only been tentatively explored.

The animal cell can be divided into two parts, the *nucleoplasm* (karyosome) and *cytoplasm* (cytosome). The nucleoplasm consists principally of the true *nucleus* which is composed of *chromosomal material*. There is also present, however, the *nucleolus* in the form of a sphere (sometimes irregular in shape). This is frequently termed the *plasmosome* when definite activity is observed in it. The nucleolus appears to be quite distinct from the chromatin of the true nucleus, although many of its staining reactions are similar. Its functions are such that it is usually considered at the same time as various inclusions in the cytoplasm, to which it appears to be functionally related.

In the cytoplasm there are present a number of inclusions.

These are of two kinds, the *protoplasmic inclusions* and the *deutoplasmic inclusions*. The former are characterised by their universality in cells, their permanence in the cell-cycle and by the fact that they appear to be definitely active organs in the cells. The deutoplasmic inclusions differ in kind between different cells; they are transitory in the cell-cycle, and they are easily recognisable as passive structures in the cells.

The protoplasmic inclusions are the *Golgi apparatus*, the *mitochondria*, the *central apparatus*, and possibly the structures, known as *chromidia*, whose relationship to the other inclusions is doubtful. Evidence will be brought forward to show that another system known as the "*vacuome*" may have to be considered as a protoplasmic inclusion, although the knowledge concerning it does not warrant any final opinion. The Golgi apparatus, if of the diffuse type, may have modified cytoplasm associated with it. In this case this cytoplasm is termed the *idiosome*, and the Golgi material attached to it the *dictyosome*.

The central apparatus consists of three parts: the central bodies or *centrioles*, the "*heller Hof*" and the *sphere* or *attraction sphere*. Owing to a temporary association of the Golgi apparatus, in certain cases only, with the central apparatus confusion has occurred, and the idiosome has frequently been termed the *archoplasm* or sphere material. There is no real connection between the two organs such as is suggested by these names.

The deutoplasmic inclusions are "non-living" granules of the secretory type, *e.g.*, fat, yolk, oil droplets, mucous and serous globules, glycogen granules, etc. They are definitely the end products of the metabolic activity of the cell, and do not take any formative part in that metabolism. The protoplasmic inclusions, however, as it will be shown later, are actively engaged in these metabolic processes.

The chief advances have been made in connection with the Golgi apparatus, its structure and function, and while some very definite facts have emerged in connection with this, it must be repeated that the most important outcome of the investigations on this and on the cell structures and functions is a general clearing of the air with regard to definition, technique and *possible*

function. A paper by Brambell, who was a pupil of Gatenby (15), on yolk formation in 1924 has formed the basis of all subsequent investigations in that direction, and Bowen, who has contributed largely to our knowledge of the Golgi apparatus, says at the end of a review of the knowledge of that cell element (12, 1927) that the position is hopeful in that certain definite problems are emerging.

In the protozoa most of the work centres round the establishment of homologies of protozoal cell elements with those found in higher forms, and therefore is closely related to pure cytology. The discovery of a neuro-fibrillar structure in many protozoa is of outstanding importance from the purely morphological point of view as well as from the physiological.

THE STRUCTURE OF THE GOLGI APPARATUS

The discovery of the reticular apparatus in the nerve cells of vertebrates by Golgi and his school of workers forms the basis of all investigations in this direction. This is so much the case that even recent conceptions of the structure and general appearance of this cell organ have been coloured by Golgi's ideas and by theories like that of Holmgren's "trophospongium," which were put forward at that time and which many workers believed were accepted by Golgi himself. Golgi described the apparatus as a reticulum or network, while Holmgren conceived of a canalicular system following the lines of the network, but essentially watery and "tubular" in character. Holmgren's views were disproved, but the possibility of internal vacuoles or canaliculæ was always present in many investigators' minds. This was complicated by the difficult techniques, often capricious in their action, employed and also by the different forms in which the Golgi apparatus was found in other cells and animals. Even as late as 1917 we find that the identity of Golgi apparatus in *Helix* is under discussion by Gatenby, a discussion reopened in 1926 by Parat and others, although not very satisfactorily. It was this very divergence in form now recognised as one of the characteristic properties of the Golgi apparatus which proved to be the chief difficulty in the way of earlier workers.

The reticulate form appears to be more or less typical of vertebrates (Fig. 52. A. B). It has been so described recently by Bowen in gland cells (10, A-D), where hypertrophy and eventually fragmentation may occur; by Ludford and Cramer in the thyroid gland and in intestinal cells (23, 81); by Brambell in the oviducal glands of the fowl (16); by Ludford in various cancerous growths

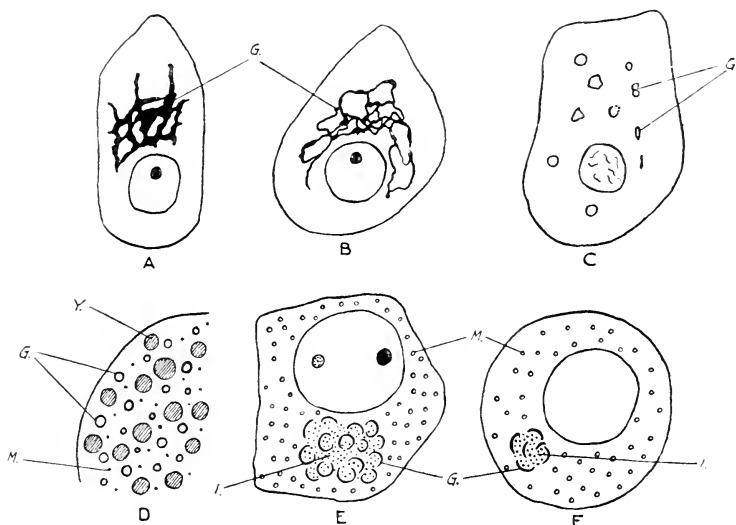

FIG. 52.—Diagrams to illustrate the form and structure of the Golgi apparatus. A and B, Golgi net-work in gland cells of the cat (after Bowen (10)). C, Golgi platelets in the oocyte of *Lumbricus* (after Harvey (44)). D, Golgi spheres or vesicles in the oocyte of the spider (after Nath (99)). E and F, Golgi rods or batonnettes in spermatocytes of (E) *Helix* and (F) *Cavia* (after Gatenby (30)). G, Golgi apparatus; I, idiosome; M, mitochondria; N, nucleus; Y, yolk.

where fragmentation may occur during the cell cycle (80); by Curry in the tubules of the mesonephros in *Necturus maculosus* (25), and by others.

In the invertebrates the typical condition appears to be as a group, collected or diffuse, of isolated bodies which have been variously described as rodlets, platelets or spheres (Fig. 52, C-E). This disagreement as to the actual form of these Golgi elements

is rather more vital than would appear on the surface. It cannot be explained away entirely on the grounds of technique, although this probably has much to do with misinterpretation of the facts. In 1925 several papers appeared which had a distinct bearing on this matter. Describing the oogenesis of *Lumbricus*, Harvey (44) maintains that the Golgi elements are here represented by small bodies (spheroids), roughly of the shape of a mammalian blood corpuscle, with a deeply staining rim and a more lightly staining centre (Fig. 52, C). These are the so-called platelets. Later in the year Gatenby and Nath (39) criticised Harvey's work and said that the Golgi elements were rods and not platelets. Their observations were made on the same material. Harvey had attempted to give an account of the various figures observed by different techniques such as those of Da Fano, Kolatchew and Champy-Kull by suggesting that the rodlets represented incomplete impregnation of the deeply-staining rim in varying quantity. His suggestions are based upon the assumption that Da Fano preparations at their best give the nearest approach to the true picture. This assumption appears to be open to criticism, although an alternative suggestion is not obvious. In 1927 Harvey (45) described the Golgi elements of the oocytes of *Ciona intestinalis* as argentophil vesicles or irregular masses. Nath and Mohan (102) quite recently have described the Golgi elements in the oogenesis of *Periplaneta americana* as vesicular bodies with osmiophilic rims. It is not at all clear how rims exist on vesicles, and as Nath, in 1928 (99), in an account of the oogenesis of a spider, found crescentic Golgi elements which he attributed to either incomplete blackening or *optical sections of vacuoles*, it is a little difficult to place much reliance on his view of the actual appearance of these bodies.

Nath, in a letter to *Nature* (97), in 1926, has quite evidently adopted the views of Parat, to which reference will be made later. He speaks of the Golgi bodies as "*rings* which may also be appropriately described as *vacuoles* with a sharp chromophilic *rim* and a central chromophobic *area*" (the italics are ours). This interpretation of the form and structure of the Golgi elements he finds very satisfactory for the explanation of the formation of

fatty yolk. Thus, in the vacuole-like elements free fat is deposited until they appear as fatty yolk spheres. This deposition apparently occurs in the chromophobic "area," as, after treatment in turpentine, osmicated tissues show only the chromophilic portion still black. On the other hand, he quotes several cases of apparent direct metamorphosis of Golgi elements into fat as corroborative evidence. As will be shown later, the whole conception of the Golgi apparatus advocated by Parat is based on entirely erroneous analogies, and most of the views of the Golgi apparatus which assume a spherical form are more or less tainted with the canalicular idea of Holmgren, to which Parat refers.

The very well-known series of papers by Gatenby on the spermatogenesis of many invertebrates (30A-I, 33, 35), and also the work of Bowen on insect spermatogenesis, make it clear that the rod is at least a very common form (Fig. 52, E, F), in which the Golgi elements appear when fixed, and any theory assuming another form, such as a vesicle, must attempt to give some explanation of the rod form after fixation. In the protozoa, Nassonov (91, 92) homologises with the Golgi apparatus of the higher forms an osmiophilic cup or hemisphere which he has described around the contractile vacuole of various ciliates. Bowen (11) and Gatenby (35) are both inclined to accept Nassonov's interpretation.

It must further be remembered that in the spermatogenesis of any given species the Golgi elements may be either diffuse or collected and fused until they form a cup or almost closed vesicle within which they secrete the acrosome (Fig. 56) (see also p. 140). Furthermore, it is difficult to conceive of vesicles having any formal relationship with the plate-like structures often fenestrated and drawn out into networks, which are found in the vertebrates.

Bowen (11) is inclined to dismiss the *exact* form as unimportant, and to consider the Golgi apparatus rather in terms of substance than form. This would permit the apparatus either to be scattered throughout the cell in discrete bodies, or else to form definite concentrations leading up to the hemisphere, plate or network.

Another feature, not of constant occurrence, however, must here be considered. This is the peculiarly modified cytoplasm

often found in connection with the Golgi apparatus—which is called the idioplasm (Fig. 52, E, F). [Many English cytologists use the term archoplasm for this structure. This is, we think, undesirable, inasmuch as the archoplasm is a term used *sensu stricto* in connection with the central apparatus, and is always associated with the centrioles. It is through the fact that the Golgi elements, with their accompanying idioplasm, are, in many much-studied cases, concentrated round the passive centrioles, that this confusion has occurred. It seems convenient, therefore, to confine the use of the term archoplasm to that structure alone, and adopt the term idiosome for the modified cytoplasm associated with the Golgi apparatus.] This material has only been observed in germinal tissue, and has not been demonstrated in somatic cells. (Bowen '22, Gatenby in oocytes; and others.) Harvey, Parat and Painlevé, and others, suggest that the Golgi material probably exists all round the idioplasm, and in fixation runs together to one side, and leaves the interior practically invisible except in those cases mentioned. This certainly accords with the peculiar fact that the idioplasm is always on one side only of the Golgi material, but it appears to be based on the Vacuome Theory, which does not find general acceptance. As already mentioned, the plate or network condition of the higher forms must constantly be borne in mind, and it is difficult to see just how the suggestion would work out in this connection.

In all probability the idiosomal material is a constant feature of the Golgi complex, and its presence on one side only may be connected with certain one-directional functional activities of the Golgi apparatus as suggested by Nessonov (91) in the case of Protozoal excretion, and as shown by Bowen (10) and others to be the case in the secretory activities of gland cells.

As regards the chemical nature of the Golgi apparatus, little progress has been made. It is generally acknowledged that it is lipoidal in nature, with probably a protein in association with it. Positive fat tests have been obtained only in two cases by Weiner and Cowdry (128, and *vide* 12). This is very small evidence for the acceptance of a view of the constitution of a permanent cell element, but it does show at any rate that the reactions can be

obtained in certain cases, and that the Golgi apparatus is real, and not an artefact.

Several observations recently have shown that the Golgi apparatus is more or less rigid, and at any rate of sufficient consistency to retain its shape when extruded from the cell (Bowen, 10B, and Avel. 1B). Brambell, for example, has described the Golgi apparatus in the secretory cycle of the ciliated epithelium of the oviduct of the fowl, and notes the Golgi fragments extruded from the cell (16).

It is remarkable that there are few cases in which the Golgi apparatus has been seen in the living cell. Strangeways and Canti (123) have been unable to trace the Golgi apparatus in the living cell grown *in vitro* under dark-ground illumination. The mitochondria and fat droplets are, however, quite visible. It is worthy of note that the process of mitosis was not too well seen, and it may be that optical difficulties, not fully appreciated, have prevented the Golgi apparatus from being seen.

Other recent workers claim to have seen the apparatus either in the living cell or else by means of a vital dye. Nath and Mohan (102) state that the Golgi elements can be seen in the oocytes of *Periplaneta americana* without the use of a vital dye, and also by staining *intra vitam* with neutral red, which tinges the Golgi vesicles pale red. King (71) also claims to have seen the Golgi apparatus in *Anoplophrya basili* in the unstained living cell and by means of neutral red. In both these cases there does not seem to be sufficient evidence to show that the structures seen are the true Golgi apparatus. The validity of the use of neutral red as a specific Golgi vital stain is extremely doubtful, and is due to an acceptance of the Vacuome Theory. As Gatenby (35) has very appropriately pointed out, the structures stained by neutral red, and termed Golgi apparatus by the supporters of the Vacuome Theory, are not universally argentophil, whereas the true or classical Golgi apparatus is consistently so.

A more reliable example is described by Rau, Brambell and Gatenby (113), who publish photographs of the apparatus stained *intra vitam* with Janus green, and by means of the Lewis method. Other cases mentioned by workers (*e.g.*, Nath) are found

to be after the application of 2 per cent. osmic for 10 to 15 minutes, but the use of the term "*intra vitam*" in these circumstances is to be deprecated.

Having thus summarised the more orthodox views on the subject of the structure of the Golgi apparatus, it is necessary to consider a theory brought forward originally by Accroyer (*vide* 12) in 1924, and subsequently sponsored and elaborated by Parat, Painlevé and their co-workers. It was noted at the commencement of this section that the canalicular nature of the Golgi apparatus, put forward by Holmgren, and afterwards generally attributed to bad technique, still lingered in the minds of many cytologists as a possible explanation of the different forms of the Golgi apparatus. This has received fresh impetus of late from the Vacuome Theory. This theory, as stated by Parat and Painlevé, in several papers (106–109), is as follows:—

All animal and plant cells have two, and only two, fundamental but independent morphological elements—the vacuome and the chondriome. The vacuome is an aqueous phase; the chondriome a lipoidal one. The vacuome consists either of isolated vacuoles, or else of a canalicular system. The vacuome stains specifically in neutral red *intra vitam*. From these premises they state that the "reticular apparatus" of Golgi, and the "trophospongium" of Holmgren (in fact the whole classical Golgi apparatus), are artefacts produced by precipitation of silver or osmium at the surface of, inside or between the vacuoles. "Il n'existe pas d'appareil cellulaire; les deux seules entités morphologiques de toute cellule végétale et animale sont le *vacuome* et le *chondriome*."

This theory was originally propounded by Accroyer (*vide* 12) in 1924, who stated that the chondriome (composed of all the mitochondrial units) can be stained *intra vitam* in Janus green; the secretory granules or vacuoles round them can be stained *intra vitam* in neutral red. This was taken up and expanded by Parat. The idea was derived partly from the canalicular theory of earlier authors, and partly by analogies with plant-cell structures. Since these analogies form a most important part of the theory itself, and no less of its criticism, it will be necessary to diverge for a moment to consider the position in plants. Two workers,

Dangéard and Guillermond, are responsible for the actual data, and although they differ slightly with reference to the chondriome, as this is not particularly relevant, it does not matter for the present argument. Both these authors identify the vacuome of plants, which appears to be of universal occurrence, with the Golgi apparatus of animals. They are driven to this conclusion chiefly because they are unable to find any other plant-cell structure to homologise with the Golgi apparatus. The chondriome, according to Guillermond, is divided in plants into two structures, an active portion (or plastidome), and an inactive part. Dangéard regards these as separate structures, although possibly related. The former he terms Plastidome, and the second the Chondriome (or sphèrome). Apart from fatty (Dangéard) or lipoidal (Guillermond) granulations, no other permanent structures could be found.

Parat starts from this position, accepts the homologies suggested by Guillermond, and further admits that neutral red is a specific stain for the vacuome. In a series of papers in collaboration with Painlevé (106-109), he deals with the appearance and structure of the vacuome in animals. First, in the salivary glands of *Chironomus* (106) he describes the mitochondria as being stained *intra vitam* in dahlia, and Janus green, but they do not take up neutral red or cresyl violet. On the other hand, dahlia and Janus green do not stain the vacuome, but this may be stained in neutral red. He considers the chondriome a lipoidal phase, the vacuome an aqueous one. Later (107) the secretory cycle in these cells is described. The vacuoles composing the vacuome grow, and running together empty themselves into the lumen and disappear, new vacuoles appearing in the reconstructed cell. During the confluent stage a definite canalicular appearance is obtained. This is compared with the figures in Da Fano and Prenant-Kopsch material, and it is suggested that this is in all probability the "trophosphonium" of Holmgren. In such material a precipitation of silver or osmium occurs on the surface of the vacuome, and thus an artefact known as the Golgi apparatus is produced.

In a third paper (108) they refer to work in various invertebrates, in cells of the stomach glands of frogs, intestinal glands,

pancreas, liver and kidney. In most cases this repeats the work of others, and demonstrates the presence of a vacuome in these cells.

Avel (1, 1A) made certain criticisms at this stage of the controversy. He pointed out that a vacuome had not been proved to exist in all animals, and questioned whether neutral red was specific for the vacuome. Both these criticisms are theoretical, and the first does not seem to hold good inasmuch as all tissues examined do appear to have a vacuome. Gatenby accepts their universality (35). The question of the specificity of neutral red is much more open to question, and Avel does not attempt to follow it up by any experiments. He says, however, that he does not find that osmic deposits occur within animal cell vacuoles as assumed by Parat and Painlevé (see above). This is corroborated by all workers.

Parat and Painlevé (108), in reply to Avel's criticism, again define their position as regards the vacuome. It can be seen without vital staining under good optical conditions if the general topography is known. It varies in position with different kinds of cells. Usually it is concentrated, but in neurons it is diffused. It is frequently found around the nucleus and near the centrosome. They reassert its affinity for neutral red and state that frequently secretory granules may be found within. By far the most interesting part of the paper is a series of drawings of the same type of cell as seen after preparation by the methods of Dietrich, Da Fano, and in neutral red respectively (Fig. 53). This does definitely establish some sort of topographical relation between the vacuome and the classical Golgi apparatus. Parat and Painlevé use this as evidence for the identity of the vacuome and the Golgi apparatus—the classical figures of the latter being only artefacts or precipitations on the true Golgi or vacuome. This cannot be accepted, we think, as nothing more than the topographical relation is indicated. It would appear that Parat is here confusing secretory granules with the apparatus. It is at any rate worthy of remark that nearly all his own data are collected from tissues of a very definitely active secretory kind.

Special mention should be made of the case of *Helix aspersa*. The original description of the spermatogenesis of this animal by

Gatenby (30B) shows that it is undoubtedly peculiar in many features. The Golgi apparatus is apparently represented by the so-called "Nebenkern." This consists of a spherical mass of differentiated cytoplasm surrounded by, or rather containing at its periphery, a number of batonnettes (dictyosomes). These obviously correspond to the Golgi bodies of other forms, the central mass being idioplasm. The situation is complicated by the fact that two kinds of mitochondria occur, the micromitosomes and

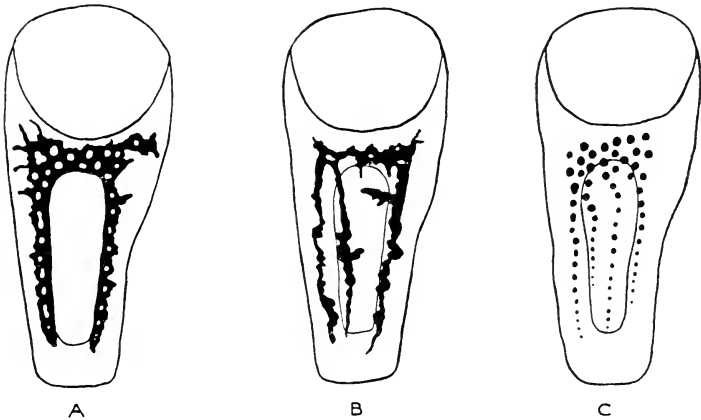

FIG. 53.—Diagrams of mucous cells from the gastric epithelium of *Triton* to illustrate the relation of the vacuome to the classical Golgi apparatus (from Parat and Painlevé (109)). A, by Dietrich's method; "chondriocontes," black; vacuome, white. B, by Da Fano's method; the classical Golgi apparatus. C, after *intra vitam* staining in neutral red; the vacuome.

the macromitosomes. These two sets take part in the formation of the tail sheaths, the former making the front sheath, the latter the hind sheath. The "Nebenkern" does not take any part in the formation of the tail sheath. It appears to be sloughed off. The formation of the acrosome is not observed.

Parat denies that the dictyosomes are the real Golgi apparatus. This latter is really represented, he says, by the vacuoles which lie in the archoplasm (idioplasm), which stain in neutral red. The batonnettes or cortex of the archoplasm are really the "lepidosome" of mitochondria. This criticism is, of course, based on the

assumption that the vacuome, stainable in neutral red, is the true Golgi, and that this stain is specific. Karpova (68) states that dictyosomes, mitochondria and other granules are stained in neutral red; furthermore, Janus green will stain both the dictyosomes and mitochondria. She does not agree with the homologies suggested by Parat, but states that the vacuoles are the canals of Holmgren and not the Golgi proper. (This view does not seem to us to differ much from that of Parat in essentials.) She concludes that the dictyosomes are really very similar to the mitochondria, and that the similar chemical composition leads one to the conclusion that they are of the same origin (*cf.* plastidome from chondriome in plants). It is, of course, admitted by nearly all workers that the Golgi apparatus and mitochondria are similar in chemical composition *when that composition is expressed in crude terms such as can be derived from coarse tests with dyes*. No microchemical tests have as yet been elaborated to separate the different proteins to any satisfactory degree.

Finally, Gatenby (35), in 1929, has shown that his original interpretations are correct. He has demonstrated the neutral red vacuoles within the Golgi, and followed the whole cycle through with intravital staining. The whole behaviour of the "Neben-kern" of *Helix* is so exactly similar to the Golgi complex of other sperms that there does not appear to be any reasonable doubt about their homology now (Fig. 55, E, F).

Bowen makes the point (12) that the very diverse form of the Golgi apparatus from the isolated bodies of the invertebrates to the plate or network of the vertebrates is not consistent with chance deposition. Further, in plant promeristem cells spherical vacuoles occur packed together closely; these blacken with osmic, but no intervening network is formed.

It has been pointed out previously that the vacuome theory is based in origin at any rate upon the supposed homology of the plant vacuome and the animal Golgi apparatus. That this homology is untrue has been shown by Bowen (12) and by Patten, Scott and Gatenby (110), who have demonstrated the presence of osmiophilic platelets in plant cells (Fig. 54).

Bowen, in 1927 (12), describes these platelets, and while not

claiming any definite homology for them, maintains that they introduce a new complexity into the problem. No longer is it a case of homologising two structures in both animals and plants. These platelets do not stain either in Janus green or in neutral red, and, therefore, whatever they may be, they belong to neither of the two previously recognised systems: the chondriome and vacuome. Later he has amplified the description, and Gatenby and others (110) have confirmed this very fully. The latter are quite definite in that they consider that the plant osmiophilic platelets are Golgi apparatus as they are demonstrated by Kolatchev and Mann-Kopsch methods. So far Benda,

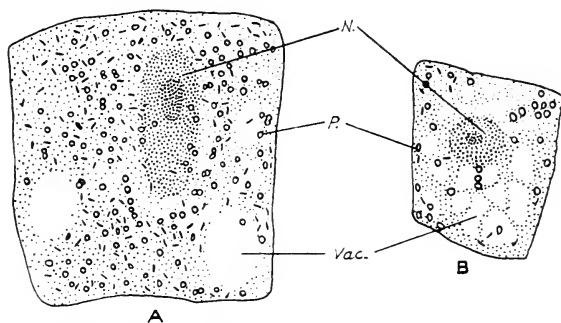

FIG. 54.—Meristem cells from root tips after Kolatchev's method (from Bowen (12)). A, in Barley; B, in Kidney bean; *P.*, osmiophilic platelets; *N.*, nucleus; *Vac.*, vacuoles.

Flemming-without-acetic and hæmatoxylin, Champy-hæmatoxylin and silver-nitrate methods have failed, but few modifications have been tried as yet.

Gatenby does not agree with Bowen as to the exact interpretation of the vacuome in plants. He considers that Bowen's vacuome is probably due to corrosive-osmium artefacts, and that the true vacuoles may be associated with the Golgi apparatus, although they are certainly not "protoplasmic inclusions," but "deutoplasmic."

This discovery, then, deals a very decided blow at the vacuome theory. The final disproof has been forthcoming quite recently in a paper by Gatenby (35), in 1929, in which he has studied the

Golgi apparatus and vacuome simultaneously by intravital methods. In *Abraxas grossulariata* in the growing spermatocyte the vacuoles are near the centrosomes, but not inside the Golgi apparatus. During the spermatocyte division they are near the chromosomes on the spindle and separate out into two sub-equal

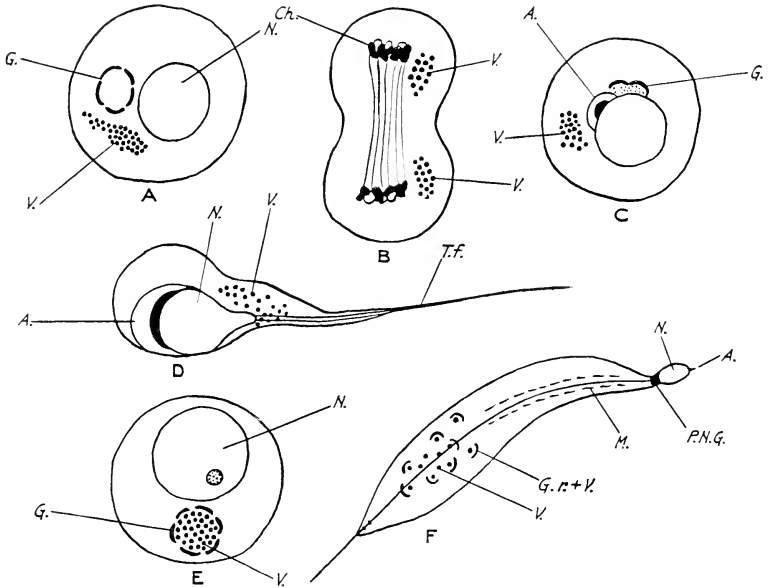

FIG. 55.—Diagrams to illustrate the relation of the vacuome to the Golgi apparatus (after Gatenby (35)). A-D, in *Cavia cobaya*. A, spermatocyte; B, spermatocyte division; C and D, spermatids. E and F, in *Helix*. E, Spermatocyte; F, spermatid. A, acrosome; Ch, chromosomes; G, Golgi apparatus; G.r.+V, Golgi rodlets and vacuoles; M, mitochondria; N, nucleus; P.N.G., post-nuclear granule; T.f., tail filament; V., vacuoles.

groups. Throughout the formation of the acrosome the vacuoles are near the Golgi apparatus (acroblast), but it is impossible to say that they are in any way active. They moved down the tail, but owing to the habits of the moth of transferring sperm in bundles with much of the Golgi and vacuolar material attached he could not state whether they were sloughed off. In *Helix aspersa*

(Fig. 55, E, F) the vacuoles are seen within the sphere formed by the Golgi elements. After the formation of the acrosome the Golgi remnants move down the tail, each usually accompanied by its vacuole. In *Cavia cobaya* (Fig. 55, A-D) the vacuoles are outside the idioplasm with its Golgi cortex, although near it. The vacuoles do not appear to play any part in the formation of the acrosome, and later move away down the tail with the Golgi remnants. The acrosome stains deeply in neutral red. He also draws attention to the Y-granules described in *Saccocirrus* (33), and places them in the vacuolar system as they behave similarly to those mentioned above. These were seen in chrome-osmium techniques, which is unusual, and such a demonstration is only likely under certain conditions. Voinov (131), for example, describes similar structures in the spermatid of *Notonecta*.

This study has therefore finally disproved the vacuome theory as enunciated by Parat and others. It remains to examine what truth underlies the facts.

There is accumulating proof of a vacuome as a constant feature of animal cells; this point was emphasised by Bowen (12). Bowen says: "I believe that in focusing his attention on the supposed relation between the Golgi apparatus and vacuoles, Parat has missed exactly what might prove to be the most interesting feature of his studies . . . the problems presented by the vacuome as such are in themselves of far-reaching interest."

These problems mentioned by Bowen are enumerated by him as follows: Is the vacuome a constant feature of the animal cell as it is of the plant? The importance of this is at once obvious. If it is simply a chance collection of secretory granules found only in certain specialised types of cell, then the problem is merely parochial. On the other hand, if it is found in all cells, then the vacuome may have to be raised to the same degree of importance as the Golgi apparatus and other protoplasmic inclusions. Secondly: what is the relationship between the vacuome and the Golgi apparatus? It is evident from Parat's observations that an intimate topographical relationship does occur between the Golgi apparatus and the vacuome in a great many cases; even allowing for some cases of mistaken interpretation. (Gatenby does

not agree with Parat in the case of the spermatocyte of *Cavia*. According to Parat, the vacuome lies in the idioplasm inside the Golgi cortex, while Gatenby considers the true vacuome as vacuoles outside the acroblast—see above.) This point has been taken up by Gatenby, and in the paper previously referred to he makes some very interesting suggestions. In the first place, in the forms in which the vacuome has been described, it is apparent that it may either be inside or outside the Golgi complex, e.g., *Helix* and *Abraxas* respectively. He is inclined to accept Nassonov's theory regarding the contractile vacuole of the protozoa, and thinks, therefore, that the contractile vacuole of the protozoa is perhaps the homologue of the vacuolar system of the metazoa. From this he argues that the archaic position of the vacuome is inside the archoplasm (idioplasm) just as in *Helix*, and possibly other forms not yet described. The vacuome may become extra-idioplasmic either later on in the cell-cycle, or else in some of the higher forms, such as *Cavia*. In *Abraxas* there is undoubtedly a very close topographical relationship, the first observed appearance of the vacuomes being in a position just vacated by the Golgi apparatus.

Gatenby concludes then by stating that the vacuome appears to be related to the Golgi apparatus, but does not think that the vacuome should be raised in status to that of a protoplasmic inclusion like the mitochondria and Golgi elements, as there is no evidence to show that it can “*per se* increase afterwards the number of its vacuoles.”

Another consequence of the vacuome theory of Parat is a certain confusion which has arisen owing to the use of the vacuolar concept of the Golgi apparatus without sufficient definition of terms and ideas. Reference has already been made to Nath (102) and King (71), both of whom seem to have accepted the vacuome theory, for they describe Golgi vacuoles seen in unstained cell *intra vitam*, a thing which is not possible with the ordinary classical Golgi apparatus, as Strangeways and Canti have shown in 1927. Their descriptions are therefore difficult to interpret. In most cases it seems to us that they have seen and described the vacuole around which the Golgi proper lies as a sort of crust or cortex. This is the interpretation given by Gatenby (35, p. 317).

A further unorthodox view should be mentioned. In two papers (125, 126) Walker, and Walker and Allen, have denied the real existence of the Golgi apparatus. In the first paper he attempts to give a *résumé* of the acrosome in spermatogenesis. It appears that he has misinterpreted the true views of workers on this subject. Much of his confusion is due to the apparent homology between idioplasm and archoplasm, which is inferred by the incorrect use of these terms by some writers. The only paper of Bowen's on spermatogenesis quoted by Walker does not set out to deal with the Golgi apparatus, but with the behaviour of the Nebenkern or mitochondria, while Bowen's two previous papers (3, 4), which deal very fully with the structure and behaviour of the Golgi apparatus and acrosome, are entirely neglected by him. In his second paper he deals with artefacts similar (*sic*) to the Golgi apparatus in appearance, produced by the usual methods for the demonstration of that organ, in artificially and synthetically produced films. He states that lecithin and kephalin in certain colloidal mixtures behave as do the Golgi apparatus. He declares, therefore, that as these two substances are known to be present in the cell, the Golgi apparatus is an artefact pure and simple.

In criticism of this it may be said that the figures produced in support of this hypothesis are very different from the true appearance of the Golgi apparatus in good preparations. Secondly, the fact that lecithin and kephalin both behave in this way and are present in the cell does no more than to present a possibility as to the chemical constitution of the Golgi, upon which light is much desired. It certainly does not account for the *remarkable, constant evolutions* through which the Golgi apparatus goes in close correlation with other perfectly well-known cell phenomena of very divergent kinds. Walker does not make any attempt to account for the constancy of appearance of the Golgi elements in definite and constant phases of the cell cycle. This fact should be faced by anyone denying the existence of the Golgi apparatus.

A final point must be raised with regard to the true Golgi apparatus. It has long been known that in the cases where it is disposed as a plate or network it is capable of considerable hypertrophy, and when in the form of isolated elements (dictyosomes)

these often grow and divide. The question of origin, however, is not completely answered by this statement, for Harvey and Brambell, among recent authors, state that formation of Golgi *de novo* occurs. Harvey (44) bases his conclusions on the presence of small osmiophilic granules considerably smaller than the typical Golgi elements. These cannot represent cut pieces of whole elements, as they lie well within the substance of the section. Brambell (16), in the cell cycle of the ciliated epithelium of the oviducal glands of the fowl, found that the Golgi apparatus fragmented and moved towards the lumen, together with the nucleus and secretory products, and that, while the nucleus subsequently moved back to the base of the cell, the Golgi fragments were extruded into the lumen with the mucus. Fresh Golgi apparatus arose near the nucleus at the base of the cell. From his figures there does not appear to be any doubt about the facts. It is of course possible that Golgi apparatus existed there before, but did not become stained. Differences of staining capacity are known in the Golgi apparatus according to the phase of metabolic activity. There does not appear to be any likelihood of a solution of this problem in the near future.

To summarise then the position at present as regards the morphology of the Golgi apparatus, it appears that this inclusion is a protoplasmic one, capable of growth, independent of other cell structure (other than the general cytoplasm), and division. Its production *de novo* is doubtful but possible.

The apparatus consists probably of a lipoid material combined with a protein of a consistency sufficient for it to maintain its individuality in the more fluid cytoplasm.

It may appear as a plate or network in the form of a ring, disc or cylinder, in which case the apparatus is continuous except during times of metabolic activity, when it may become irregularly fragmented and distributed throughout the cell. In other forms it occurs as individual elements, either collected into one definite locality or else scattered in the cytoplasm.

Although modified cytoplasm, known as idioplasm, is normally only found to accompany the apparatus in germ cells, it is also probably present in all cells, although not demonstrable. This

idioplasm is situated on one side of the fixed Golgi elements, these appearing either as platelets or batonettes (rodlets). A secretory granule or vacuole may occur within the idioplasm, and it has been suggested that the real situation of the osmiophilic Golgi is as a sphere round the idioplasm with its vacuole. This is probably incorrect, as it does not fully take into consideration the plate-like form of Golgi apparatus unless the sphere is envisaged as incomplete. It is doubtful whether this would form a stable system, although it is not impossible.

Associated with the true Golgi apparatus there appears to be a vacuolar system primitively situated within the Golgi cortex, but which may be outside it. This vacuole is probably a deutoplasmic inclusion, being incapable of independent duplication and growth. (Voinov seems to think the vacuoles enlarge in *Notonecta*, however.) The vacuole stains intravitaly in neutral red, and is watery and probably acid in nature.

THE FUNCTION OF GOLGI APPARATUS

It is in the direction of elucidating the problems connected with the function of the Golgi apparatus that most progress has been made during the last ten years. Although the apparatus was discovered in the nerve cell a function was found first in the animal sperm. This process culminates in the formation of the acrosome or tip of the spermatozoon and was described by a number of workers, among whom Gatenby and Bowen stand out.

In the spermatid the scattered Golgi elements, with their accompanying idioplasm, collect into a clump with the idioplasm in the centre (idiosome) and the Golgi bodies on the outside (cortex). This complex, which is not in connection with the centrioles at this stage, is termed the *acroblast*, as from it is formed the acrosome (Fig. 56). This acrosome is of one of two types—vesicular or granular. The former is found in Mammalia, Amphibia and Hemiptera. It is formed inside the acroblast in the idioplasm and, as the complex is close to the nucleus and the cortex appears to be incomplete on the side nearest the nucleus, the acrosome projects out from the acroblast and touches the nucleolar membrane. Usually inside the acrosome is found a

small granule termed the acrosomal granule (Fig. 56, B, C). The granular acrosome is found in *Paludina* (Gatenby), and *Columbella* (Schizt). The exact character of the granule is not clear. It may be either the limiting type of the vesicular acrosome or else the acrosomal granule itself without any vesicle surrounding it. The remains of the acroblast, known as the Golgi remnant, pass down the tail and are sloughed off with the residual protoplasm,

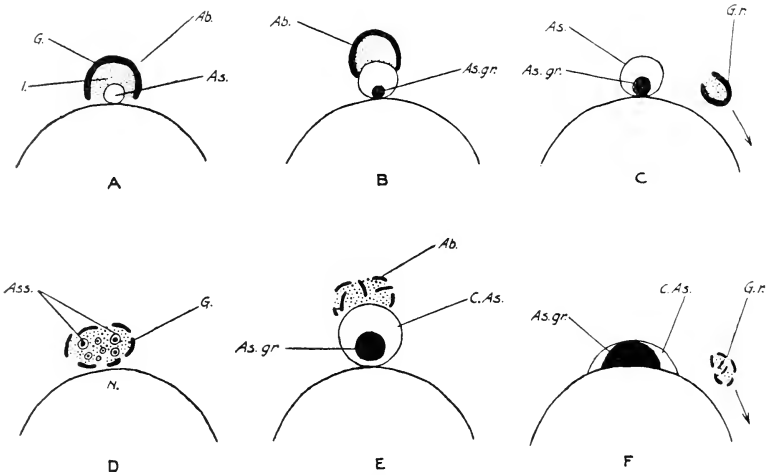

FIG. 56.—Diagrams to illustrate the formation of the acrosome. A, B and C, in Hemipteran spermatids. D, E and F, in mammalian spermatids (from Bowen (10D)); (A, B and C, after Bowen; D, after Lenhossek; E, after Meves; F, after Gatenby and Woodger). *Ab.*, acroblast; *As.*, acrosomal vesicle; *Ass.*, acrosomal vesicles; *As.gr.*, acrosomal granule; *C.As.*, compound acrosome; *G.*, golgi material; *G.r.*, golgi remnant; *I.*, idiosome; *N.*, nucleus.

while the acrosome comes to lie at the tip of the metamorphosing spermatozoon (Fig. 56, C). Either the acrosome is deposited by the acroblast on the nuclear membrane, whence it moves over the surface until the required position is taken up (*e.g.*, Hemiptera), or else, as in the case of mammals, the acroblast accompanies it to the tip, deposits it *in situ*, and then moves back down the tail.

In other forms, such as the grasshoppers, moths, etc. (3, 4, etc.), although the essential character of the process is the same,

a peculiar divergence of procedure occurs. Instead of the aggregation of the isolated dietyosomes into a compound acroblast, each dietyosome secretes in its own idioplasm a vesicle. These vesicles subsequently run together to form a compound aerosome. There is no reasonable doubt that the aerosome is secreted by the Golgi cortex with or without the assistance of the idiosomal material.

Writing in 1924, Cowdry (22), in speaking of the function of the Golgi apparatus, is unable to come to any conclusion or even to point the way to any possible general function of the Golgi. "At present it is unwise to be too specific. Since the whole cell is our unit it is altogether likely that the portion of the cytoplasm which is revealed to us in fixed preparations in the form of the now familiar Golgi apparatus may take part in many different vital manifestations. . . . Its activities may be bent in one direction during spermatogenesis and along entirely different lines in cells specialised to perform other duties."

The first step towards an understanding of the function of the Golgi apparatus was taken by Nassonov (89) in 1923, when he suggested that the phenomenon of secretion might be connected with the Golgi apparatus. He pursued his own line of thought in later papers which will be dealt with below, but it was left to Bowen to approach the matter from the point of view of the Golgi apparatus. In a series of papers (10A-D) he has shown past all doubt that the Golgi apparatus is very intimately connected with the production of secretory granules in many well-known glands.

Bowen started with Nassonov's findings and attempted to correlate them with his own work on spermatogenesis. (It must be clearly understood that at that time (1924) the formation of the aerosome was put down to secretory activity of the acroblast and that it was practically the only case completely understood from the morphological point of view.) He was quite clear that the suggestions made were merely hypothetical, and the final proof of them must consist of "a demonstration that the general topographical relationship of Golgi apparatus and secretory glands is always such as to allow a possibility of the existence of some more intimate association; an extension of our knowledge of the finer structure of the Golgi apparatus, especially in somatic cells; and

a critical demonstration of the relation of the individual secretory granules to the detailed structural features of the Golgi apparatus." (The term secretion is in all cases used to refer to the production of a granule within the cell ; excretion refers to the act of extrusion from the cell.)

He describes the secretory cycle in a large number of glandular tissues, such as salivary glands—parotid and submaxillary glands of the cat, salivary glands of *Limax* ; pancreas—in salamanders and cat ; liver—cat. All these are glands of the alimentary canal and produce secretory granules of either the mucous or serous type (Fig. 57). In both types of cells the Golgi apparatus, which is in the form of a network, undergoes very considerable hypertrophy at the onset of the secretory cycle. At that point, however, the two types of cell cease to agree. The mucous secretory granules grow fairly rapidly after their appearance and soon reach their maximum size (Fig. 57, C). They are then pushed outwards towards the lumen away from the Golgi network, which remains more or less compact near the nucleus (between it and the lumen). Fresh granules then make their appearance amongst the network until the whole cell is packed with mucous granules (Fig. 57, D).

The serous cells show a different and more significant cycle. The granules do not appear to attain their full growth at once, but the Golgi network, which is greatly hypertrophied, extends throughout the mass of granules and remains in intimate contact with them until they are full-grown (Fig. 57, F–H). The granules all appear to reach their full size at about the same time.

In the case of *Limax* the Golgi apparatus is represented not by a network, but by the scattered Golgi bodies characteristic of the invertebrates. The same relationships exist here between the Golgi bodies and the secretory granules as in the case of Golgi network.

The importance of the different behaviour of the Golgi apparatus in serous and mucous cells lies in the fact that it suggests that the Golgi apparatus is definitely concerned in the process of secretion. How else explain the different behaviour of the Golgi than as an expression of physiological (chemical) differences in the act of secreting different substances ?

Bowen states and his figures prove that "a very close topographical relation was found between the Golgi material and the developing secretory granules."

In a second paper (10B), Bowen deals with lipoidal secretions found in the so-called skin glands—inguinal gland of the rabbit, Meibomian glands of the cat, oil glands of the chicken and duck,

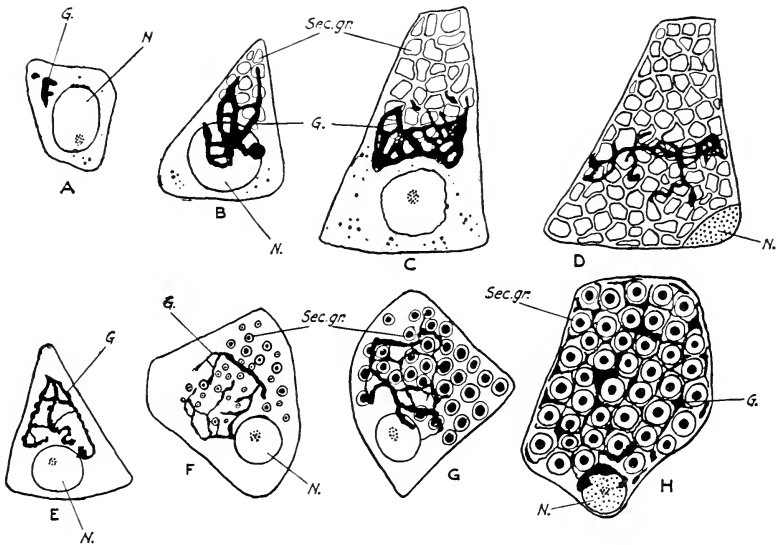

FIG. 57.—Diagrams to illustrate the relationship of the Golgi apparatus to the secretory cycle (after Bowen (10A)). A-D, in mucous cells from the submaxillary gland of the cat. E-H, in serous cells from the parotid gland of the cat. A and E, show commencement, D and H, the end of the secretory cycles. G., Golgi apparatus; N., nucleus; Sec.gr., secretory granules.

Harderian gland of the rabbit. In these glands the general process resembles that in the serous gland cells. The Golgi apparatus hypertrophies and appears rather flocculent like that described by Cuttaneo (*vide* 11) for the mammalian egg. Bowen thinks this is very significant. The granules of lipoidal substance grow in size, associated with Golgi material, which shows a decided tendency to fragment. This tendency to fragment increases as the cycle progresses, and the granules are inclined to run

together into large globules with Golgi fragments upon their surfaces.

Finally, Bowen deals with lachrymal glands producing a watery secretion, and also glands of the male reproductive system. In the case of the lachrymal glands, such as the tear gland of the cat, Harderian gland of the duck and the infra-orbital gland of the rabbit, the general cycle is similar to that of the mucous glands. The Golgi reticulum lies near the nucleus away from the lumen. The granules appear amongst the reticulum, and as they are formed are pushed towards the lumen. The Golgi apparatus undergoes hypertrophy, but never loses its position or extends far up the cell. Great complexity of the network characterises the onset of secretion. In the glands of the epididymis of the cat he was not able to follow the secretory cycle completely owing to his inability to demonstrate the secretory granules. Hypertrophy of the Golgi apparatus seemed to occur in the middle and end of the cycle. His most interesting point is in connection with the epithelium of the vas deferens. In the cells of this tissue a reversal of the "normal" position occurs and the apparatus is found below the nucleus away from the lumen. This condition had been reported previously by Cowdry, and has also been remarked on subsequently by Cramer and Ludford in the thyroid gland. Cowdry believed it to be the result of the secretion passing outwards into blood vessels instead of into the alveolus. Cramer and Ludford cannot agree with this, and do not find activity of the Golgi apparatus directed towards the blood vessels at this time. Bowen's interpretation of the reversed polarity in the epididymis is the same. He can find no evidence of reversal of direction of secretory activity. He concludes that a reversed polarity of the cell produced by a change in the position of the Golgi apparatus has no influence on the secretory cycle.

Nassonov had meanwhile pursued another line of inquiry, which has proved equally good. In two papers (91, 92), he has described the contractile vacuole and its related structures in Protozoa after using Golgi methods of preparation (Kopsch, Kolatschev). His material of the first paper consists of Holotrichan infusoria (*e.g.*, *Paramæcium caudatum*), Peritrichan infusoria (*e.g.*, *Vorticella* sp.),

and a Flagellate (*Chilomonas paramaecium*). The results of impregnation may be briefly summarised.

In the case of those protozoa possessing simple contractile vacuoles, such as the Peritricha studied, and forms of the Holo-

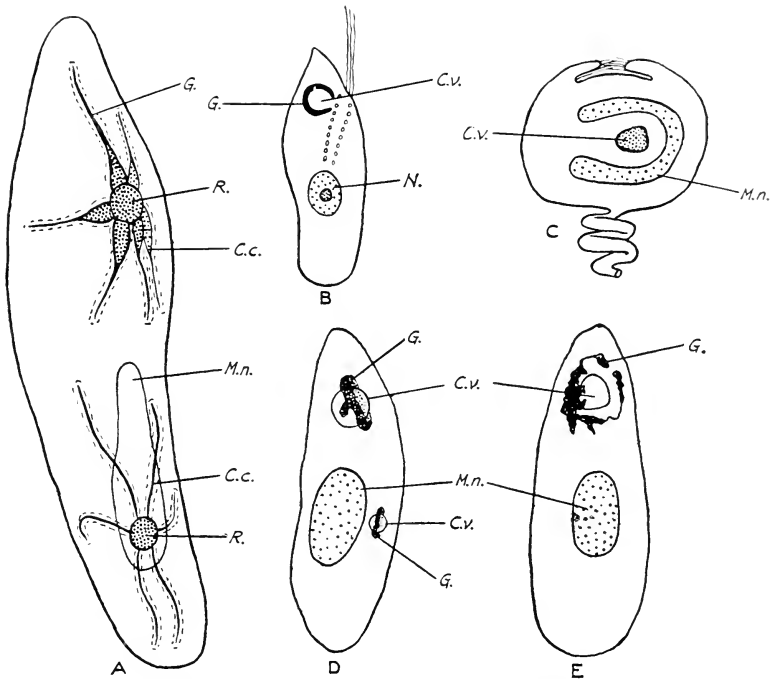

FIG. 58.—Various Protozoa to show the contractile vacuoles and their relation to the Golgi apparatus (after Nassonov (91 and 92)). A, *Paramaecium caudatum*. B, *Chilomonas paramaecium*. C, *Vorticella* sp. D and E, *Dogiella sphaerii*. C.v., contractile vacuole; C.c., canals; G., Golgi apparatus; M.n., mega-nucleus; N., nucleus; R., reservoir.

tricha like *Lionotus folium* and *Nassula lateritia*, the contractile vacuole wall was deeply impregnated in all stages from systole to diastole. In *Paramaecium caudatum*, in which there is present a compound contractile vacuole consisting of the central reservoir and its contributory canals, the impregnation occurred not only around the central reservoir but also in the walls of the canals,

which were shown to be continuous with those of the reservoir (Fig. 58, A). In systole the impregnated wall of the reservoir was small and darkly stained and the canal impregnation reduced almost to rods. In diastole, however, the canals in section appeared as rings and the reservoir was large and lightly impregnated.

In *Chilomonas paramaecium* the simple reservoir was deeply stained round its periphery, although the point of opening into the pharynx was free from impregnation (Fig. 58, B).

The impregnation is in all cases very definite, limited and intense. Nassonov concluded that the "membrane" so impregnated secreted (or excreted) the fluid found in the contractile vacuoles at diastole.

His own work on the connection between secretion and the Golgi apparatus of the Metazoa, taken together with this new example, leads him to homologise the walls of the contractile vacuoles of the Protozoa with the metazoan Golgi apparatus. This is based not merely upon similarities of staining reactions, but also upon the general morphology and, most important of all, upon similar function. As regards the morphology a general resemblance will be seen between the incomplete sphere of the impregnated wall of the contractile vacuole and the form of the Golgi during acrosome formation and during cell secretory activity. Homologies based on morphology of the Golgi apparatus cannot be pressed too far, as we have seen that the present view does not stress the importance of the actual morphological form.

In respect of the functions it is quite evident from Nassonov's own preliminary work (and Bowen's later very exhaustive survey) of the relation of the Golgi apparatus in gland cells to secretory activity that secretion of various granules or vacuoles is a common function of the Golgi apparatus. The excretion of fluid into a contractile vacuole is an exactly comparable process. In fact it may be acknowledged that secretion and excretion are frequently identical and the choice of the terms depends upon the point of view. Nassonov therefore feels justified in asserting the homology outlined above.

Objections were raised against this hypothesis chiefly upon the

grounds of technique. Hirschler (*vide* 11), for example, found that impregnation of the nuclear membrane could be obtained on occasion. All such criticisms were done away with, however, in the second paper by Nassonov (92), for they were based on the fact that the impregnated structure demonstrated by Nassonov lay close or was definitely apposed to the wall of the contractile vacuole, and therefore deposition of silver or osmium might occur at the surface and produce an artefact.

In *Chilodon* sp. the impregnated region is in the form of a ring or girdle encircling the vacuole. There is no question of the impregnation of a general vacuole-cytoplasm surface. Furthermore, in *Dogielella sphaerii* the apparatus (as it may now be confidently termed) is not only in the form of a ring but stands well away from the vacuole (Fig. 58, D. E). The ring appears flattish in section and is composed of a lattice work of fairly fine texture. Nassonov compares it with the condition found in the cells of the epidermis of the gills of the axolotl larva, with which, from his illustrations, it is practically identical.

It may be taken for granted therefore that in those protozoa possessed of a contractile vacuole the Golgi apparatus of the metozoa is represented by a lipoidal substance in the neighbourhood of the walls of that vacuole. This homology, important as it is from the morphological aspect, is doubly so from the physiological or functional point of view.

To turn now to other work described at about this time, we find that a considerable amount of unconnected data and observations were made. Brambell, in 1923 (14), describes the behaviour of the Golgi apparatus in the neurones of *Helix aspersa*. The apparatus consisted of rodlets in a homogeneous argentophil cloud round the nucleus. In the large neurones this cloud was almost absent on the side of the nucleus near the axon, and in small neurones the cloud was confined to the side of the nucleus, well away from the axon base. The so-called Tigroid bodies (Nissle granules) were always associated with the Golgi bodies. It is, of course, well known that the Golgi apparatus usually undergoes hypertrophy when repairs are being carried out to the nerve fibres, but Bowen (11) drew attention to the general agreement of

authors that the Nissle granules and the Golgi apparatus are associated in *many distributions*. Brambell put forward the suggestion that the Golgi apparatus was responsible for the production of these Nissle granules; so far no evidence has been brought forward to contradict this view. Rau and Ludford (114), however, in 1925 attribute the remarkable size and complexity of the Golgi apparatus in nerve cells to the high degree of metabolism present. This explanation is, however, couched in rather general terms and seems to be an hypothesis of doubtful value.

Confirmatory evidence of Bowen's work is found in several papers. Brambell (16), in 1925, drew attention to the part played by the Golgi apparatus in the secretions of the oviducal glands of the fowl. In the alveolar glands the Golgi network is actively engaged in the production of the albuminous granules. General hypertrophy takes place during this activity and a corresponding reduction in size occurs during the periods of rest. The ciliated epithelium is also secretory and a similar cycle is met with. The Golgi apparatus fragments, however, and is extruded at the moment of excretion, the apparatus being reformed *de novo* at the base of the cell near the nucleus.

Cramer and Ludford (24), in 1926, investigated the activity of the thyroid gland in mammals. Control of the secretory cycle can be effected by various means (discovered by Cramer), and the secretory condition of the glands was therefore known before fixation and examination. In resting glands the Golgi apparatus was much contracted and the mitochondria highly staining and very small (Fig. 60, A, B). In active glands, however, the Golgi apparatus is largely convoluted and undergoes considerable hypertrophy (Fig. 60, C, D). The mitochondria enlarge enormously. They conclude that the Golgi apparatus is related to secretion and that the mitochondrial activity is connected with the production of variations in surface energy within the cytoplasm, thus assisting in the redistribution of lipoids. This conclusion is of considerable interest.

The Golgi apparatus was also enlarged with the mitochondria in cases of exophthalmic goitre in mouse and man (81); the polarity of the Golgi apparatus was frequently reversed. They suggest

that the secretory products may be directed outwards. Bowen, it will be remembered, did not consider this conclusion necessary.

The same two workers in 1925 (23) showed that the Golgi apparatus was very actively concerned in the process of resynthesis of fats from fatty acids and glycerol in the cells of the intestinal epithelium. An enormous hypertrophy of the Golgi apparatus occurred. The mitochondria appeared unchanged throughout the activity. There is no doubt as to the synchronism of the Golgi activity and the resynthesis, as known conditions were produced by experimental feeding. The resultant fats can also be demonstrated cytologically.

In the case of the kidneys observations by Curry (25), in 1929, after excessive excretion experimentally induced, showed that no significant variations in inter-relations of granules, globules, mitochondria and Golgi apparatus occurred. The explanation suggested is that the kidneys are normally so active that the increase induced was small and so did not cause a sufficient difference in the inclusions. This is very probable. It must be remembered that the kidneys differ from the true glands in that their activity is constant and continuous, whereas glands such as those referred to above all have alternating periods of rest and activity. Furthermore, the peculiar and very constant form of the Golgi apparatus in all kidneys of vertebrates indicates that some correlation exists between the apparatus and the specialised function of the cells.

The Golgi apparatus in other cells appears to be fairly small. Such exceptions as there are, are significant. Epithelia undergoing cornification have an hypertrophied Golgi apparatus (Deineka and Cajal). Similarly, in connective tissues forming adipose tissues or in the formation of cartilage and osteoblasts, hypertrophy occurs.

From data such as these has grown up the general theory of the function of the Golgi apparatus. Nassonov first put it forward, but Bowen has been instrumental in obtaining its general acceptance, in these terms :—

The Golgi apparatus is a centre of synthetic processes. It is engaged primarily in the production of secretory granules. These

may be excretory in nature. These products are of a temporary character, such as mucous, serous, lipid granules, yolk, acrosome, Nissle granules, etc. The apparatus undergoes hypertrophy during the process and *is not transformed into the various products*. This feature is constant in all the foregoing examples, and is the fundamental postulate for the so-called "Process theory of action."

So far no mention has been made concerning the function of the Golgi apparatus in the female germ cells except the reference to yolk in the preceding paragraph. This is because the evidence in this connection is more equivocal than that previously brought forward. The whole question of the formation of the yolk will be considered in detail later, but the part played by the Golgi apparatus will be briefly reviewed now.

In 1920 Gatenby and Woodger reviewed the general position as regards the formation of yolk (41). As regards the Golgi apparatus the only positive evidence is found in *Patella*, where the dictyosomes are in the form of rods on the surface of the yolk spheres. Comparison with the process in *Limnaea* led them to suggest that probably the archoplasm (= idioplasm) became loaded with lipins and fats, and thus metamorphosed into yolk. During embryogeny it was supposed that these bodies yielded up their nutritive material and so once more became protoplasmic inclusions. Thus it will be seen that the idea that the Golgi apparatus might play some part in the production of the deutero-plasmic yolk spheres was entertained even at that time. No actual mention of secretion occurs, and even in 1924 Brambell in a paper inspired by Gatenby repeatedly speaks of "Golgi yolk" as yolk "*formed from the Golgi elements*" (italics ours), and not as yolk produced by the Golgi apparatus. This idea of the metamorphosis of a protoplasmic inclusion into a deutero-plasmic one is recurrent in the English literature concerning the formation of yolk. Nath, for instance (93, etc.), describes one kind of yolk as being derived from a direct metamorphosis of the Golgi apparatus. Nath and others have published a series of papers during the last five years all dealing with this aspect. A consideration of one by Nath and Mohan in 1929 will illustrate his general attitude. The

Golgi apparatus can be seen in the living oocytes of *Periplaneta americana*, both with the aid of neutral red and unstained. The bodies were vesicular, with osmiophilic rims. As explained in the previous section, Nath is probably describing an osmiophilic sphere—the true Golgi dictyosome—surrounding a vesicle of cytoplasm corresponding to the idioplasm. In the maturing oocyte these bodies spread throughout the cytoplasm and the rim (spherical shell = dictyosome) becomes attenuated as the interior becomes packed with fatty yolk.

There does not appear to be much doubt that the description given above is that of the secretion by the Golgi bodies (dictyosomes) of the fatty yolk. This is done just as the acrosome is secreted, namely, inside the dictyosome. It is exactly comparable with the case of *Patella* quoted above, except that *Patella* has the dictyosome as batonnettes, but here they appear to be spheres. (As already pointed out, Nath's explanation of the crescentic bodies in sections does not satisfy us, and it may indicate that the sphere is an incomplete one, just as it is in the formation of the acrosome and in the Flagellate reservoir.)

In 1926, Bowen (11) in reviewing the literature was unable to come to any definite conclusion. He considered that the whole question of yolk formation was in hopeless confusion. (Brambell's paper in 1924 had done much to clear the air, and from that the progress in this direction really dates.) Bowen makes the suggestion, however, following Brambell, that one kind of yolk, namely, the fatty yolk, lipoidal and blackened by osmic, light and oily in character, was formed by the Golgi apparatus. This conclusion was more or less essential for his particular theory at that time, although subsequent researches appear to have confirmed his suggestions to a certain extent.

Harvey, in the eggs of *Ciona intestinalis* (45), describes what appears to be a modification of this process. According to him the yolk arises partly from the material of the yolk nucleus, which is albuminous, and partly from lipoidal substances extruded from the follicle cells into the egg. These two materials are compounded by the mitochondria into yolk by taking them into their own substance, while retaining the individuality of the

mitochondria. The important point is that the Golgi apparatus appears to produce the yolk nucleus in the early oocyte. This, being albuminous, differs from the previous cases and may be regarded with suspicion. The other accounts of the development of the yolk in *Ciona* do not agree with this. Hirschler (49) says the yolk nucleus is derived from the cytoplasm and that the Golgi apparatus contributes lipoid material to the yolk droplets formed by a previous swelling of the mitochondria. Neither of these accounts seems entirely satisfactory.

Lastly, Ludford (74) believes yolk to be formed in *Patella* by the Golgi bodies in much the same way as the acrosome. This appears to fit in with the theory enunciated above, and certainly conforms most nearly with the Process theory of action.

Summarising now the present position as regards the function of the Golgi apparatus in animal cells, we find a general tendency for this cell inclusion to act as a centre of synthesis. The actual substance of the apparatus does not seem to take any material part in the process of synthesis except as an enzyme or as the producer of enzymes. In a review of the behaviour of the Golgi apparatus in various types of cells it has been shown that many different kinds of substances may arise as deutero-plasmic inclusions as the result of its activity. Even in the single class of the gland cells, mucous, serous and lipoidal secretions, all arise from the activity of the Golgi apparatus. In the male germ cell the watery acrosome is produced by the Golgi complex, and in the female germ cell there is a growing body of evidence to show that some of the yolk (lipoidal) at any rate is formed by the Golgi elements. The same marked contrast between the characters of the products can be seen in the nerve cells, where formation of the Nissle granules is apparently the function, and in the thyroid gland, activity or the resynthesis of fats from the fatty acids and glycerol in intestinal cells.

Having regard to this great variety of the products of Golgi activity, it is only in general terms that any working hypothesis can find expression at present. It seems likely, however, that in the future, with the continued elaboration of technique and the

advances in microchemical tests, a more definite description of the function of the Golgi apparatus will be given.

MORPHOLOGY AND FUNCTION OF THE MITOCHONDRIA

As the investigations of cytologists have been turned to the form and function of the Golgi apparatus, so the mitochondria have been neglected. It is a remarkable thing that so little is known positively about one of the "best-known" protoplasmic inclusions. Cowdry, in his summary of the knowledge of the first-class mitochondria in 1924, had to admit that nothing of importance was really known about them.

A considerable mass of data has been collected so far regarding the form and behaviour of these structures, but there does not seem to be a sufficiently strong link to warrant any really general statement concerning their function. There has been carried out a very interesting and suggestive piece of work by Horning, which will be described in detail below, which appears to make a definite move in the right direction. We are still very far, however, from being able to explain in terms of function such specialised behaviour as the formation of the tail sheaths in many animal spermatozoa.

The chemical nature of the mitochondria appears to be somewhat similar to that of the Golgi apparatus, namely a protein substance compounded with a lipin. The micro-chemical reactions of mitochondria are, however, not constant. This may be due to the accumulation of deutoplasmic substances within them, but there are several cases where the mitochondria do not appear to stain typically, and these cannot at present be correlated with any particular activity of such a kind.

The general form of mitochondria has been well known for a long time. They are usually filamentous, the length greatly exceeding their thickness. In many cases, however, they show that this is only one of many variations, the other extreme being small spherical granules. Intermediate shapes are known, both the filamentous and granular appearances occurring in the life-history of one animal, or in the course of the cell cycle. Growth

is generally accomplished by an elongation of the main axis. There appears to be a consensus of opinion, however, that the mitochondria are capable of storing material within their substance. Under these latter circumstances enlargement in the other two axes takes place, the mitochondria becoming¹ fatter instead of longer, as in the case of true growth.

The generally-accepted criterion of activity of the mitochondria is growth. This may either take the form of elongation without division, in which case they may assume very long filamentous forms, or else division may take place as rapidly as the elongation, so that a great multiplication of mitochondria takes place. This is frequently found as a recurrent phase in gland cells. Another form of activity is probably shown by the other form of enlargement, namely by a swelling of the filaments or granules. The actual nature of this action is not known. It is found most frequently in oogenesis and spermatogenesis.

There are other cases, to which reference will be made later, in which a definite activity apparently takes place, but is associated with neither of these changes in form, but rather by a diminution in size, and even total reduction.

One of the problems of the earlier workers was the actual standing of the mitochondria as cell organs. Many workers were inclined to believe that they were really symbiotic bacteria, since many of their reactions are the same, and that such differences as exist are due to the fact that they are quite definitely modified for the symbiotic mode of life, and that this has probably been going on for a very long time. The question is not entirely one of technique, as evidence that mitochondria arise *de novo* would militate strongly against the symbiosis theory. On the other hand, it must be remembered that it is extremely difficult to prove such an origin, as it may be that the mitochondria are not really absent, but are merely in a non-staining phase in the cell, and that their apparent production *de novo* is simply a return to a stainable phase. The weight of the evidence is, however, on the side of those who maintain that the mitochondria are definite cell organs of an equal standing at least with the Golgi apparatus, with which they are classed as protoplasmic inclusions.

This conclusion was reinforced recently by the discovery of a vital dye known as Janus red, which is the sodium salt of diethyl-safranine monocarboxylic acid. This dye, found by Brailsford Robertson, has been employed by Horning (61), and found to stain mitochondria selectively, leaving bacteria unstained. The variety of bacteria tested does not leave much doubt as to its specificity. Although Janus green B was fairly selective, it also stained other cell organs, such as the Golgi apparatus, in certain cases (*Helix* spermatids), and also some forms of bacteria.

Using this and other methods of demonstrating mitochondria, Horning has investigated their distribution, form and function in the protozoa and some metazoan cells (pancreatic cells).

As regards their distribution, they appear to have a distinct tendency to adhere or remain near to protoplasmic surfaces. Thus they are found in dense aggregates on and about the surface of the nucleus (63). He was unable to trace any penetration of the nuclear membrane, as Rikita Honda had claimed. In all probability the latter's claim is based on badly-fixed material. He debates the possibility of their adherence to the surfaces being a surface tension phenomenon. The final suggestion is that it is explainable on the grounds of their phosphatidal nature. Phosphatides, like other fatty substances, tend to collect at interphase surfaces, since they reduce surface tension.

This explanation is also used to account for their position in other parts of the cell. In *Opalina* and *Paramecium* they may be found arranged in rows just below the cuticle, between the bases of the cilia (64). Their disposition is different in the two cases. In *Opalina* they are arranged as rods, the long axes of which lie at right angles to the longitudinal rows of cilia, parallel to the surface of the cell. In *Paramecium* the mitochondria lie end to end in rows, so that the long axes of the rods lie parallel to the row of cilia. It is suggested by Horning that as the general distribution is similar, the differences may be explained on the grounds that in *Opalina* the rows of cilia are wide apart, and thus allow the mitochondria to lie across between the ciliated lines, but in *Paramecium* the cilia are close together, so that the mitochondria must lie lengthwise. Although only two cases are thus quoted to

uphold the suggestion, it does seem a likely one, since in the rest of the cytoplasm of *Opalina* and *Paramœcium*, and in fact in many other cells in which lined structures are not present, the mitochondria lie haphazard in the cell.

The last case of adherence of mitochondria to surfaces men-

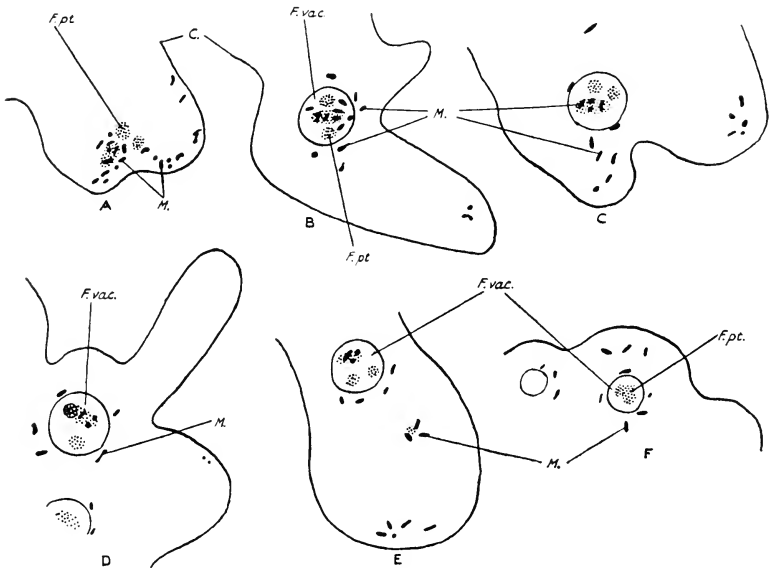

FIG. 59.—Portions of *Amœba* showing the process of digestion in relation to the mitochondria (from Horning (61)). C., cell outline; F.vac., food-vacuole; F.pt., food-particle; M., mitochondria.

tioned by Horning is also the most interesting from the point of view of the function.

Observed in both living and stained preparation, the mitochondria in *Amœba* have been seen to adhere to engulfed food particles (65). So far as he has been able to see, the mitochondria become attached to the food as it commences to circulate through the cell (Fig. 59, A). No mention is made of an enclosed vacuole of water engulfed with the food; in fact evidence definitely controverting that idea is found later in the process. The mitochondria on the food particle apparently secrete, cause to be

secreted, or merely have secreted around them a watery vacuole, the well-known food vacuole (Fig. 59, B). The food particle commences to disintegrate as digestion proceeds, the mitochondria enclosed by the vacuole with the food become smaller and less densely staining (Fig. 59, D, E). Finally the mitochondria inside disappear; the food vacuole becomes very small, indicating the passage of digested foodstuffs out into the cytoplasm (Fig. 59, F), and the faecal remains are shot out. It is a matter for remark that although many mitochondria become attached to the outer surface of the food vacuole during its passage through the cell, not one has been seen to pass through and enter the vacuole and take part in the processes of digestion which are undoubtedly going on inside. No mitochondria appear able to pierce the vacuolar "membrane" or surface when once it is formed, so that only those actually adhering to the food particle are included within the vacuole.

There is not much doubt that the mitochondria are largely responsible in this case for the production of enzymes for the process of digestion. It is probable also that they actually give up their own substance for this purpose, for even if we assume that they merely become unstainable rather than actually disintegrate, it must be admitted that they never take any further part in the activity of the cell, as they would be cast out with the faecal remains. Before continuing with this particular line of inquiry, some other work by Horning must be mentioned in connection with the form and structure of the mitochondria.

He has traced the various stages of the mitochondria through the life cycle of *Opalina* (59) and *Monocystis* (66). In the first case (*Opalina*), he finds them as twisted filamentous structures undergoing multiple longitudinal fission in the asexual multiplicative phase of the cell. Before encystment they undergo transverse fission repeatedly to produce spherical bodies, in which condition they apparently remain during encystment and in the gamete stage. When the zygote is formed they commence to fuse together and form larger bodies, which secondarily break up into elongate filamentous particles again, for the asexual phase.

In *Monocystis* the mitochondria are present throughout the

asexual life cycle as rods, but at the onset of spore formation they decrease in size and numbers. In the spore no mitochondria can be seen, but they reappear in the sporozoite as soon as it is liberated. Horning believes them to be reformed *de novo*, and therefore that they have ceased to exist as individual inclusions during the spore stage. This is of course possible, but we do not think that the technique for demonstrating mitochondria is sufficiently advanced for us to be able to say that because they are not visible they have entirely disappeared as cell inclusions. Theoretically, of course, such a statement can never be justified, although the presumptive evidence may be very strong. Such evidence is not really forthcoming, however, in this case. The lapse into small spheres of small staining capacity may here be more emphasised than in the case of the spherical bodies of *Opalina* cysts, but both appear to be correlated with the small metabolic activity as Horning suggests, and there does not seem to be sufficient justification for assuming that the mitochondria disintegrate in one case and not in the other.

To return to the previous point regarding the function of the mitochondria; it would seem that the evidence of Horning in *Amæba* leaves little doubt that the suggestion that the mitochondria are the seat of enzymatic activity must be taken seriously. On the other hand, a great deal of negative evidence is forthcoming. For instance, Cramer and Ludford have shown that the process of fat absorption in the mammalian intestine is associated with a hypertrophy of the Golgi apparatus, but the mitochondria remain unchanged throughout the cycle (23). The same two workers, however, in the case of the thyroid gland, note that both Golgi and mitochondria are enlarged during secretion (Fig. 60). Their figures show, and they write of, an enormous enlargement of the mitochondria, accompanying a convolution of the Golgi apparatus (24). They give as an explanation that the Golgi apparatus is probably actively engaged in the actual production of the secretion, but that the mitochondrial variations produce corresponding variations in surface energy within the cytoplasm, and thus effect redistribution of the lipoids. If this were the whole story one might be excused expecting similar phenomena in the

intestinal fat-absorbing cells. A perusal of the very considerable amount of work carried out by Ludford (23, 24, 77-81) will show that although the actual amount of our knowledge of the behaviour of these cell organs is increasing enormously, it is still practically impossible to correlate the various phenomena satisfactorily. Horning, however, claims to have found that the zymogen grains

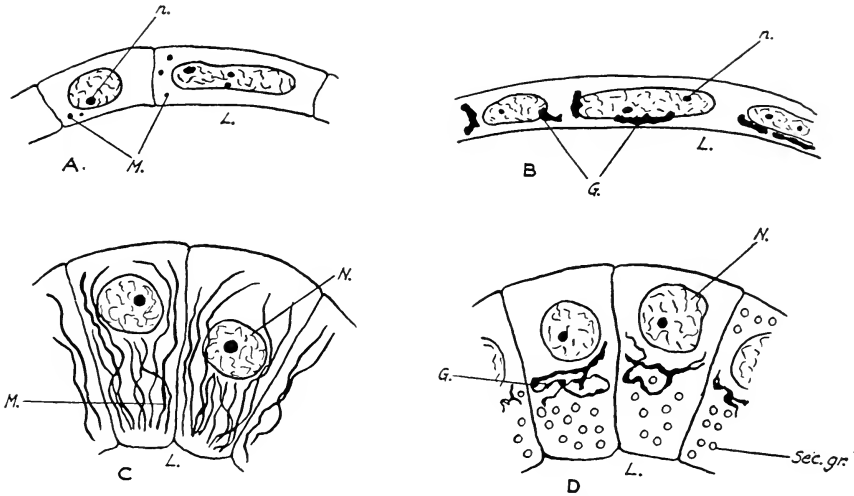

FIG. 60.—Cells from the thyroid gland showing the differences in form of the Golgi apparatus and mitochondria in resting and active phases (from Cramer and Ludford (24)). A and B, Resting glands from animals fed with thyroid or exposed to heat. C and D, Active gland from animals given tetrahydronaphthylamin or exposed to cold. *G.*, Golgi apparatus; *L.*, lumen; *M.*, mitochondria; *N.*, nucleus; *n.*, nucleolus; *Sec.gr.*, secretory granules.

of the pancreatic cells in the guinea-pig are formed from the filamentous mitochondria (58).

In the case of specialised cells, such as the male germ cells, the position appears to be even more confusing. In the spermatogonium and spermatocyte they are present as filaments or granules (Figs. 63, A, 64, A). During the spermatocyte divisions they do not appear to separate into two subequal groups, but remaining near the spindle in the centre of the dividing cell, become mechanically cut into two groups by the developing cell wall (Figs. 63, C, 64, C)

(Bowen, 4). During spermateleosis they appear to undergo very extraordinary changes. They first of all collect into a mass on the side of the nucleus on which the centrioles now lie. This mass is termed the Nebenkern (Fig. 64, D). The subsequent history varies somewhat, and it is not possible to make a connected description. Doncaster and Cannon (20, 26), in 1920, working on the louse, state that the granular mitochondria become vacuolated so that the Nebenkern appears as a mass of foam. The outer vesicles fuse to form larger ones. This process continues until near the spermatocyte division the outer vesicles have become only two in number and hemispherical in shape. Inside there is a mass of more deeply-staining vacuoles. After the unequal division of the cell the mass moves back into the mass of protoplasm gathering on the tail, but was not actually seen to be sloughed off owing to technical difficulties. They further emphasised that the so-called mitochondrial spireme seen by Gatenby in the Nebenkern was due to optical section of the vacuoles in the inner mass.

Bowen returns to this point in a paper (7) in 1922. He conceived the typical Nebenkern to consist of two parts. The outer, or chromophobic, is derived from the medullar of the original mitochondria forming the mass; the inner, or chromophilic, is from the cortex of the mitochondria (Fig. 64, D, E). He does not explain how the readjustment necessary to produce this condition is obtained. However, he considers the inner chromophilic mass to exist in many forms. For instance, it may be in spiremes in the Lepidoptera (Gatenby, 30A), or as plates in the Hemiptera (Bowen). Eventually the whole central mass disappears in the Hemiptera, although as this takes place faintly-staining vacuoles appear within the chromophobic outer vesicles. These vacuoles, by coalescence, form the core of the tail sheaths (Fig. 64, F, G).

Bowen insists that very varied techniques should be used in problems such as these, so that only the best preparations—those considered most nearly to conform to the condition in the living cell—are used. This really only moves the problem a step further in a circular direction, and although his own platework in the Hemiptera may correspond essentially with the mass of vacuoles (vacuolated platework?) of Doncaster

and Cannon, the spireme of Gatenby does not seem wholly explicable.

Gatenby in 1922 described the very remarkable formation of tail sheaths in *Saccocirrus* from the Nebenkern (33). This occurs entirely during spermateleosis. The mitochondria composing the Nebenkern run together to form larger and larger droplets, until finally three sub-equal large spheres are formed. These elongate tremendously and form the tail sheath. In this case there is no division into inner and outer parts or any complicated formation of secondary vacuoles such as that described by Bowen in the case of the Hemiptera.

So far then all that can be said of the mitochondria in spermatogenesis is that they appear to metamorphose either directly or indirectly into the tail sheaths when the latter are present. As to the function of the tail sheaths or how they are actually produced nothing is known.

In the process of oogenesis and particularly of vitellogenesis, the part played by the mitochondria is again in considerable doubt. The general behaviour of the mitochondria may be fairly briefly summarised. In most cases the mitochondria are either invisible or else few in number and more or less scattered in the oogonial stage. As the oocyte enters upon the growth period, the mitochondria appear to clump themselves together and form what has frequently been termed a "yolk nucleus." (N.B.—This term has often been applied to structures other than mitochondrial.) This usually breaks up sooner or later, and the mitochondria are found to be fairly evenly distributed.

On the whole the general opinion is that the mitochondria do not metamorphose into yolk and that they do not appear to take any direct part in vitellogenesis. As an example may be taken the oogenesis of *Lumbricus*, described by Harvey (44) and by Gatenby and Nath (39). These observers differ fundamentally on several points, but they agree that the so-called yolk-nucleus is formed of mitochondria. Harvey says they are filamentous, while Gatenby and Nath describe them as granular, attributing the filamentous condition to artefacts. They also agree that the mitochondria are not metamorphosed into yolk. Similar con-

clusions will be found in most of Nath's papers on oogenesis (93-102).

The case of *Ciona intestinalis*, also investigated by two workers, requires a certain amount of notice. Hirschler (49) derives yolk granules from the mitochondria, and finds that vitellogenesis is completed by a fusion of these granules with the Golgi bodies. The mitochondria themselves are derived from the original yolk nucleus which appears as a granule in the very early oocyte. Harvey (45) also states that the mitochondria swell up to form the ultimate yolk spheres of the mature ovum. The process described is however very different from that stated by Hirschler. The mitochondria are not derived from the yolk nucleus, being found present together with it at the very earliest stage. The swelling of the mitochondria comes about by the compounding by the mitochondria of albuminous material in the form of the "yolk nucleus" (secreted by the Golgi apparatus) and of lipoid material contributed by the test cells, into the yolk spheres of the late oocyte. Harvey is quite clear that he thinks that although the mitochondria take an intimate part in the formation of the yolk, they do not lose their identity as definite cell inclusions.

In concluding a *résumé* of our knowledge of the function of the mitochondria in oogenesis, it is necessary to mention one or two significant features. Firstly the two cases of *Lumbricus* and *Ciona* are not incompatible. For this very good reason: we had occasion to point out that the evolutions of the mitochondria during spermatoteleosis were undoubtedly significant of something but that it was impossible to say exactly of what. The same applies here in the case of oogenesis. The complicated formation known as the yolk nucleus followed by the spreading out of the mitochondria must be of some importance. So far no facts have been brought forward which completely bar the possibility that the mitochondria are employed either directly or indirectly in vitellogenesis.

In conclusion then, the only progress made in connection with the mitochondria is that there does appear to be a plausible possibility that the mitochondria are actively concerned either in actions themselves enzymatic in nature, or in the manufacture of

enzymes which will in turn carry out a process of catalysis or synthesis in the animal cell. In this connection it is not unjustifiable to point out that in plant cells there is every reason to believe that the chief cell organ of synthesis—the plastid system—is phylogenetically related to the chondriome of plants.

THE NUCLEUS AND NUCLEOLUS

We pointed out in the introduction that the main phenomena connected with the nuclear cycle were elucidated by the end of the war. Certain problems such as the demonstration cytologically of crossing over, and the possibility of parasynapsis and telosynapsis are always present, but they have faded rather from the cytologist's view during the present decade. It is true, however, that the work of Hogben (55-57) did much to demonstrate parasynapsis in animal cells whatever the conditions found in plants may be.

The most important feature of the cytology of the nucleus in recent years is the demonstration by the school of Muller in America of "translocation" and its related phenomena (86-88, 103). When chromosomes in germ cells are exposed to X-rays in appropriate doses they are found to exhibit a tendency to fragment. This phenomenon has been known for a good time, but it now appears that these fragments, although they may remain separate, often become attached to one of the other non-homologous chromosomes. This rearrangement of the chromosomal material is stated by the geneticists to be associated with differences in the genetic behaviour. It is found that some of the mutations normally associated together (linked) in breeding experiments are now associated with different groups of mutations. A complete correspondence between the genetical facts and the cytological observations is difficult to establish in *Drosophila* on account of the similarity in appearance of the second and third chromosomes. But it appears that similar alterations in the linkage groups occur between the autosomes and the sex-chromosomes. Thus, a translocation from III to Y (Fig. 61, C) has enabled a distinction to be made between the second and third chromosomes. This establishment of the third chromosome as

distinct from the second (cytologically) has permitted the observers to study them more minutely and it is now possible to distinguish definitely between the second and third chromosomes and so establish cytologically translocations between the second and third. "Chromosome II contains more chromatin than III and typically appears as longer, or, when relatively condensed, thicker. How-

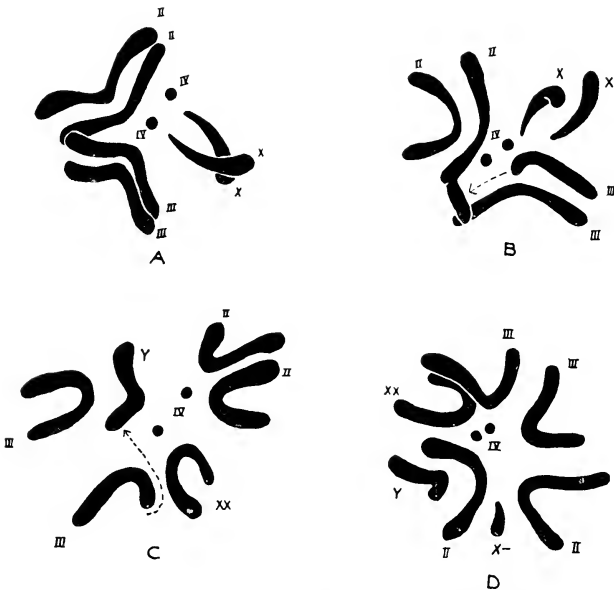

FIG. 61.—Chromosome figures from *Drosophila* to show translocation (B and C) and deletion (D). A represents normal condition. Roman figures refer to the number of the chromosome pair, X and Y to the sex-chromosomes; XX is the "added X" condition and X- indicates deletion. The dotted lines show the probable translocations (from Painter and Muller (103)).

ever, it is not always possible to distinguish between the two because these studies also show that the rate at which the chromosomes of different pairs in a given cell contract is subject to a good deal of individual variation" (88).

Fragments have been found to be detached from any one of the X, II and III (88, 103), and Y (119) chromosomes, and they may be attached to any of the other (non-homologous) chromo-

somes (Fig. 61, B, C) including the fourth. Translocations involving the second and third are the most numerous apparently, either chromosome being the donor. (We do not intend to enter into the genetic data here as they are irrelevant to the cytology except as confirmatory evidence.)

Another modification induced by X-ray application is known as "deletions." These occur in the X-chromosomes (Fig. 61, D). Many cases are known involving a large or small portion of the chromosome and differences in the transmission of the sex-linked characters have been observed in these cases as well.

The importance of these discoveries from the point of view of the cytologist lies in the fact that the possibility of chromosome fragmentation and fusion with other chromosomes is now demonstrated and can be used as a working hypothesis in treating the chromosome groups of related species.

For instance, the work of Metz (83) has shown, a good time ago, that the chromosome groups in various species of *Drosophila* could be accounted for on the assumption that either fragmentation or fusion of chromosomes had taken place. This has now been demonstrated as a fact in X-radiated forms.

It must be remembered that these cytological observations are all made from embryonic or somatic tissues and not from germinal. This does not invalidate the results at all, but it certainly puts a limit to the possibilities of cytological confirmation of the behaviour during germ-cell formation in the maturation divisions. Several early attempts were made to investigate spermatogenesis in *Drosophila*, e.g., Stevens in 1908. These were more or less unsuccessful owing to the difficulty of handling the material adequately. (The gonads are surrounded with fatty tissue, which prevents the penetration of most good cytological fixatives.)

Metz has, however, recently given a description of spermatogenesis in *Drosophila funebris*, which species he found the most favourable (84). Synapsis apparently occurs between homologous chromosomes in the telophase of the last spermatogonial division. The sex chromosomes remain relatively condensed and attached to or incorporated in the nucleolus. In the early growth phases of the spermatocyte the autosomes become so diffuse that

no account could be given of their detailed behaviour. No distinctive leptotene and early diplotene stages could be made out, but the chromosomes became distinct again in the metaphase of the heterotype division. They are, however, irregular in outline, and no flat metaphase plates could be found except in *D. obscura* and closely related species. The distribution of the chromatic material, however, is perfectly regular. The second division is much more normal and presents no special peculiarities. Metz observes many interesting cytoplasmic structures but does not analyse them. These structures are believed to be the so-called scattered chromosomes of Jeffrey and Hicks. Comparison on an accurate basis is, however, impossible, as the two latter workers use Carnoy's solution for "fixation." This fixative, although a good penetrant of chitin and fatty tissue, is not good cytologically.

There is little doubt that this description of Metz requires confirmation, and much that may be interesting from a theoretical point of view would probably result.

Turning to the nucleolus we find that a considerable amount of attention has been given to this organ from various aspects. For instance in 1920, Hogben described processes of nucleolar emission of granules in Hymenoptera (55), *Periplaneta* (56) and *Libellula* (57). This was done primarily with the view of sustaining the individuality and continuity of the chromosomal material throughout the germ-cell cycle. It also had another significance, for, as pointed out by Hogben in the case of *Periplaneta* and *Libellula*, these emissions are apparently connected with vitello-genesis.

In the case of the Hymenoptera studied by him (*Synergus* and *Formica rufa*) nuclear particles were ejected as the germinal vesicle became lightly staining. They migrated to the cytoplasm, fragmented and acquired an enclosing membrane. They were, however, transitory in nature. In *Periplaneta* the process is more complicated. During the earlier stages of the oocyte, particles are emitted from the nucleolus, or plasmosome,

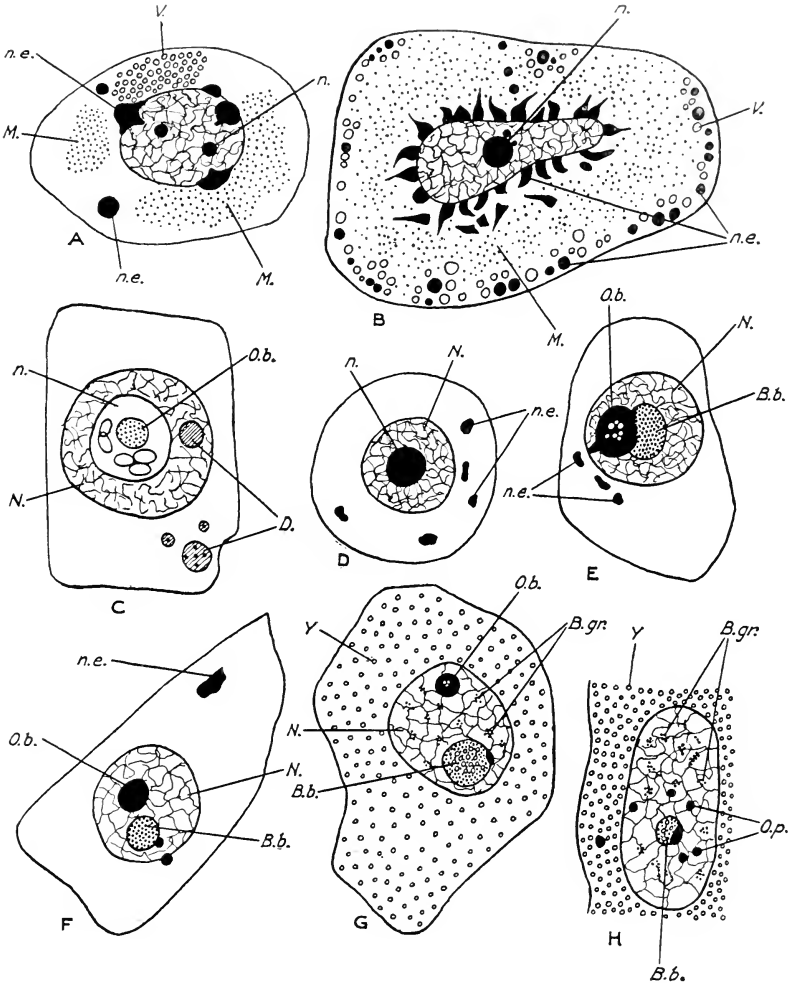

FIG. 62.—Various cells illustrating nucleolar extrusion. A, Spermatoocyte of *Saccocirrus* (after Gatenby (33)). B, Oocyte of *Saccocirrus* (after Gatenby (33)). C, Oocyte of *Libellula depresso* (after Hogben (57)). D, H., oocytes of *Patella* (after Ludford (75)). B.b., basophil body; B.gr., basophil granules attached to nuclear reticulum; D., deutosomes; M., mitochondria; N., nucleus; n., nucleolus; n.e., nucleolar extrusions; O.b., oxyphil body; O.p., oxyphil particles; V., Y-granules (vacuome); Y., yolk granules.

which is deeply staining. These disappear, and the plasmosome is seen to contain vacuoles. These vacuoles are in turn emitted and new vacuoles formed, which follow the others into the cytoplasm. These vacuoles are termed by Hogben deutosomes, as they become yolk.

In *Libellula depressa* the nucleolus is differentiated into two concentric regions (Fig. 62, C). Intranucleolar vacuoles make their appearance during the growth phase one at a time and emerge first into the nucleus and then into the cytoplasm, where they pass to the periphery, break up and form yolk. They thus are deutosomes.

Ludford, in *Patella* (75), describes a very complicated process of nucleolar extrusions which apparently result in part in the formation of yolk. The nucleolus is here definitely differentiated into two parts which lie, separated eventually from each other, in the nucleus (Fig. 62, D-F). One part is oxyphil, the other basophil. Extrusions continue during the differentiation, particularly from the increasingly basophil part. The oxyphil portion dwindles and fragments, and is ultimately extruded into the cytoplasm, where it is apparently related to yolk formation (Fig. 62, D-H). The basophil portion fragments, the granules becoming attached (?) to the lignin network (Fig. 62, G, H).

The almost classical case of nucleolar emissions is described by Gatenby in the case of *Saccocirrus* (Fig. 62, A, B) (33). Nucleolar extrusions commence at an early stage and continue throughout the oocyte. The extruded portions remain attached to the nuclear membrane, where they undergo differentiation, becoming the centre of vacuoles inside of which the nucleolar granules partially break up. On the absorption of the vacuoles the granules are scattered throughout the egg as deutoplasm (Fig. 62, B). "The deutoplasm forms dense clouds of heavy granules throughout the entire egg cytoplasm."

Gardiner (29) states that there are definite nucleolar extrusions in the oogenesis of *Limulus polyphemus*, and that with the help and interaction of chondriosomes, dictyosomes and ground cytoplasm, yolk is formed. However vague this account, it does connect the extrusions with yolk formation. Both King (69) and

Nath (93) describe in the oogenesis of *Lithobius forficatus* two phases of nucleolar extrusions. The first are budded off and extruded (King), and give rise to secondary nuclei (Nath). King does not trace their fate ; Nath says they disappear. The second phase of nucleolar activity differs from the first in that the nucleolus itself fragments, and is apparently totally extruded. King says they grow into yolk spheres, while Nath states that they disappear before the appearance of vitelline (albuminous ?) yolk, but thinks they may have something to do with it. (The two researches were carried on independently and practically simultaneously.)

Spaul (117) attributes the formation of yolk to the nucleolar extrusions in *Nepa*. Harvey (46), in *Carcinus mænas*, also states that nucleolar extrusions are associated with the yolk droplets. Nath, in scorpions (96), describes basophil and oxyphil extrusions. These disappear later as the albuminous yolk becomes prominent. He does not trace any direct transformation from nucleolar extrusions into yolk droplets. The same author has stated that the basophil bodies lying in the acidophil nucleolus of the oocyte of *Luciola gorhami* (101) breaks up, migrates into the cytoplasm, and gives rise directly to albuminous yolk. The nucleolar budding in this case lasts throughout oogenesis. He also finds, however, that there are no extrusions in the spider *Crossopроза lyoni* (99), although there is albuminous yolk and in the centipede *Otostigmus Fææ* (100) only a few extrusions take place, which disappear long before the albuminous yolk puts in its appearance. Nath and Mohan, in *Periplaneta*, describe the albuminous yolk as nucleolar in origin, the extrusions moving to the periphery of the cytoplasm and then breaking up into small bodies evenly distributed. They subsequently grow enormously in size. Gatenby finds, in *Sycon compressa*, nucleolar extrusions in oogenesis, but is unable to assign any definite function to them (32). King, in *Peripatopsis capensis*, notes nucleolar budding in very young oocytes. These have, however, only been traced as far as the nuclear membrane (70). Hirschler, of course, attributed a nucleolar connection to the yolk nucleus in *Ciona intestinalis* (49), and Harvey, although he states the yolk nucleus to be formed by the Golgi apparatus, conceives the

possibility of the actual material being derived from the nucleolus. The yolk nucleus is in this case albuminous in nature (45).

Sufficient data have been brought together above to show that there is a growing consensus of opinion that the nucleolus, *viâ* its extrusions, may be associated with the formation of the albuminous yolk. It is evident, of course, that there are many discrepancies, but many of these may be due to differences of the subject under investigation. Further work may well lead to a general clearing up of this matter.

Practically nothing more can be said at present regarding the function of the nucleolus, and it is evidently a field in which investigation will be amply repaid.

SPERMATOGENESIS, OOGENESIS AND YOLK FORMATION

Spermatogenesis. Most of the important features of spermatogenesis have been described under the headings of Golgi apparatus and mitochondria, but a short account is due to correlate the various structures and to refer to the behaviour of some other cytoplasmic inclusions.

The mature sperm consists of a head, middle piece and tail. The head is made up of a tip called the *acrosome* and the concentrated nucleus. The acrosome is usually considered to have a penetrating function, but Bowen does not agree with this (9). According to him, the shape of the acrosome does not lend support to this theory. For instance, in mammalia it is a round, blunt cap, fitting over the nucleus (Fig. 66, G). Furthermore, he maintains that the acrosome is not always terminal. Quoting Goldsmith's Coleopterous work, he says that there the acrosome is at the side of the nucleus, and parallel with it. In *Lepisma* he himself finds the acrosome behind the nucleus (9), which reduces the cutting tool idea to an absurdity. Gatenby, however, has re-examined the spermatogenesis of *Lepisma domestica* (38), and finds the acrosome in the usual tip position, and thinks that Bowen has mistaken the rather large post-nuclear body for it. On these lines Bowen would have misinterpreted Goldsmith's work. This post-nuclear body lies at the base of the head and joins it on

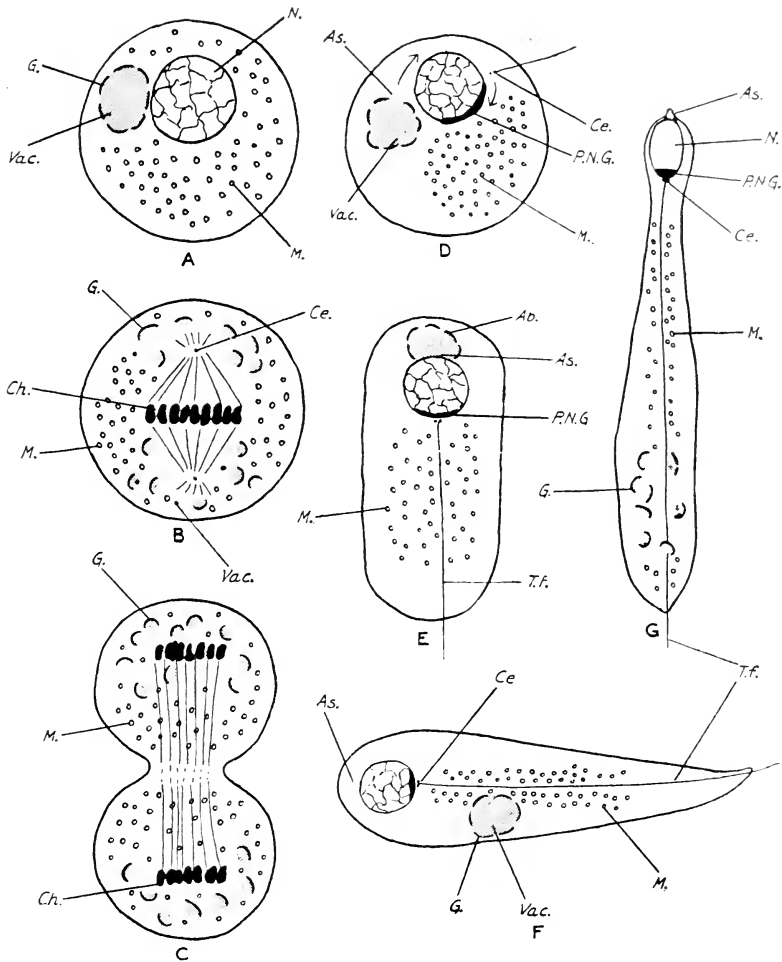

FIG. 63.—Diagram of spermatogenesis in *Helix* (after Gatenby (30b), 35). A, Spermatocyte. B and C, Spermatocyte divisions. D, Early Spermatid. E, F, G, Spermatoleosis. *Ab.*, acroblast; *As.*, acrosome; *Ce.*, centrioles; *Ch.*, chromosomes; *G.*, Golgi apparatus; *I.*, idiosome; *M.*, mitochondria; *N.*, nucleus; *P.N.G.*, post-nuclear granule; *T.f.*, tail filament; *T.s.*, tail sheath; *Vac.*, vacuome.

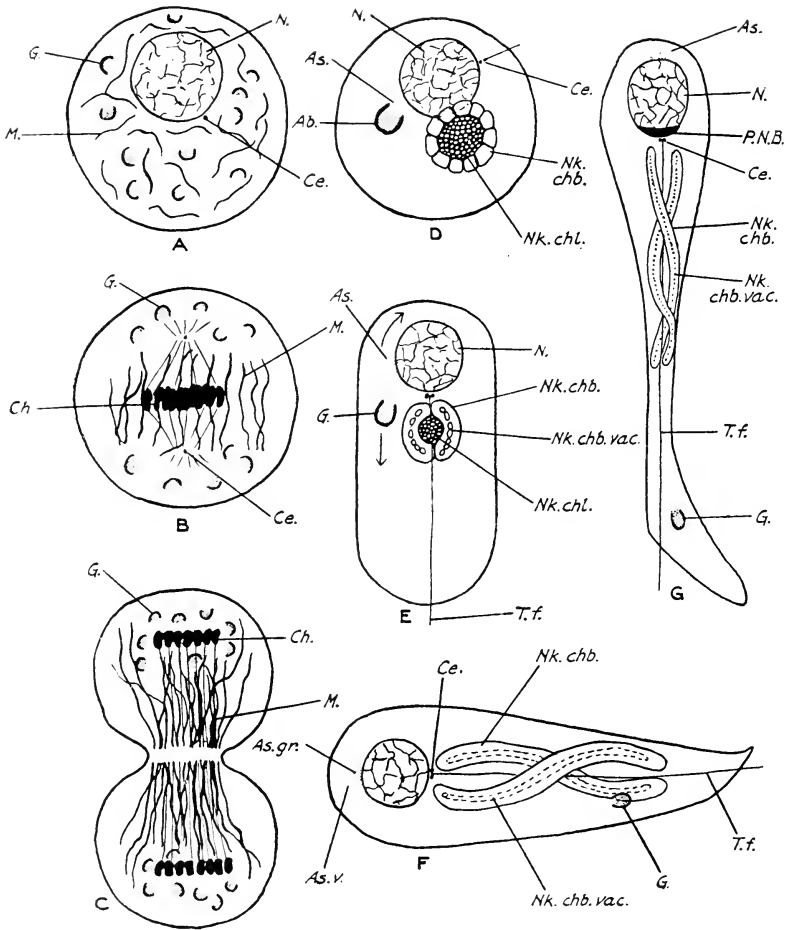

FIG. 64.—Diagram of spermatogenesis in the hemiptera (after Bowen (3, 6 and 7)). For details of lettering see Fig. 63. In addition: *As.v.*, acrosomal vesicle; *As.gr.*, acrosomal granule; *Nk.*, Nebenkern; *Nk.chl.*, central chromophilic mass of Nebenkern; *Nk.chb.*, cortical chromophobic mass of Nebenkern; *Nk.chb.vac.*, vacuoles in chromophobic cortex of Nebenkern.

to the middle piece (Fig. 63, G), which contains the *basal granule* of the tail filament. It has a fairly thick cytoplasmic sheath. The tail itself contains only the tail filament surrounded by a very delicate cytoplasmic envelope.

The structure of the spermatocyte is quite simple, and very unlike that of the spermatozoon. The nucleus is eccentrically placed, and has by its side the Golgi apparatus, which consists (according more or less to the method of fixation) of a spherical shell incomplete on the side apposed to the nucleus, a reticulum or a number of rodlets (batonettes) arranged or enclosing a mass of modified cytoplasm, the idiosome (Fig. 66, A, etc.). In the centre of the idiosome are the centrioles (Fig. 66, A). There is no definite connection between these two structures, although they are associated in this phase. In the later spermatocyte the Golgi apparatus with the idiosomal material breaks up into separate Golgi bodies (= rodlet + idiosomal cytoplasm), and becomes scattered throughout the cell. The mitochondria at this stage are in the form of granules or filaments, and are usually evenly distributed (Figs. 64, A, 65, A).

In the spermatocyte divisions the Golgi bodies are gathered into subequal groups, and accompany the centrioles as they separate on the formation of the spindle (Figs. 63-64, B, C). The mitochondria, however, usually lie around the spindle, and are only separated into two groups by being mechanically cut in two by the formation of the inter-cellular wall (Fig. 64, C).

The resultant spermatids are very like the late spermatocytes, but are, of course, much smaller (Figs. 63-66, D). Now follows the process of spermatoleosis, or metamorphosis, of the spermatid into the mature spermatozoon.

The centrioles are usually at what is to be finally the anterior, or "tip" end, of the spermatozoon. They are packed in between the nucleus and the cell wall (Figs. 63-66, D). On the other side of the nucleus there comes to be formed the acroblast. This is derived from the Golgi bodies by their fusion into a spherical form with the idioplasm inside (Figs. 63-66, D). In the centre of this is formed the acrosome (Figs. 63-66, D). In some forms, such as the mammalia, hemiptera and amphibia (Bowen), the acrosome

is vesicular, and inside it there is to be found an acrosomal granule (Figs. 64–66, E). In *Paludina* (Gatenby, 30D), the acrosome is granular, and may be either the acrosomal granule or else a limiting form of the vesicular type (Fig. 63, E). In the Acrididæ and certain moths (Bowen and Gatenby), a complex acroblast is formed. Each Golgi body forms an acrosome on its own (Fig. 65, D). These vesicles then fuse together to form a compound acrosome (Fig. 65, D).

The acrosome is deposited towards the surface of the nucleus, and its movement to the future anterior end of the spermatozoon may be accomplished in one of two ways. For example, in the Hemiptera the vesicle is deposited on to the nuclear membrane, and moves over the surface of it to the front of the sperm (Fig. 64, D, E); while in the mammals the vesicle and the acroblast all move to the anterior position, where the acrosome is deposited and the Golgi remnant (as the acroblast is called after deposition of the acrosome) moves back again (Fig. 66, D, E). In both cases the Golgi remnant appears to be cast off as the spermatid gets rid of its surplus cytoplasm. Meanwhile the centrioles have moved round the nucleus, being usually diametrically opposite the acroblast and acrosome (Fig. 66, D, E). Thus at the final stage of acrosomal deposition they lie posterior to the nucleus (Figs. 63–66, F, G).

The mitochondria during the formation of the acrosome have massed themselves posterior to the acroblast and formed the Nebenkern (Figs. 64, 66, D). They swell up and form a vacuolated mass (Fig. 64, D). The actual constitution of this mass appears to vary considerably, and even in the same form different interpretations are put upon it. As far as can be seen there are two portions, an outer chromophobic and an inner chromophilic (Fig. 64, D). This is reported by a number of workers, *e.g.*, Bowen and Doncaster and Cannon. The chromophilic substance is variously disposed. Doncaster and Cannon speak of it as vacuolar, and attribute the spireme condition (Gatenby in Lepidoptera) to optical sections of the cortices of the vacuoles. Bowen, however, thinks that the different patterns are due to different techniques (7). The ultimate fate of the Nebenkern is obscure. In many forms it is sloughed off with the surplus protoplasm and Golgi remnant, but

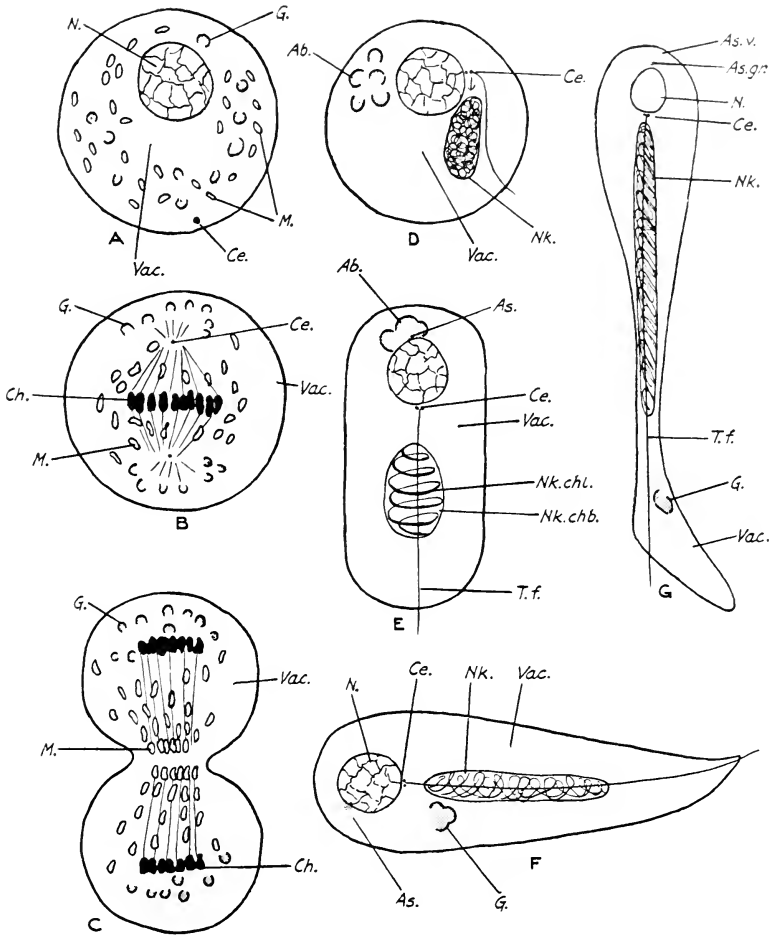

FIG. 65.—Diagram of spermatogenesis in the Lepidoptera (after Gatenby (30a, 35)). For details of lettering see Figs. 63 and 64. Note the compound formation of the acrosome.

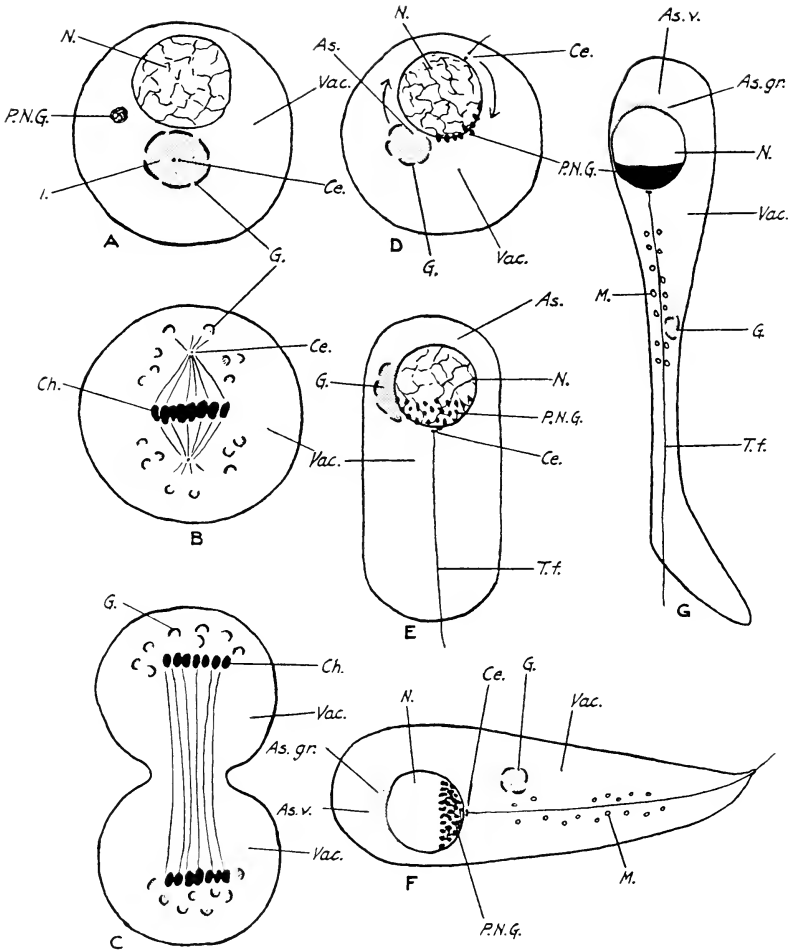

FIG. 66.—Diagram of spermatogenesis in *Cavia* (after Gatenby (30i and 35)).
For details of lettering see Figs. 63 and 64.

where tail sheaths are present these are formed from the chromophobic material (Figs. 64, 65, E-G). No satisfactory explanation of the evolutions of the Nebenkern has been given as yet.

The tail filament arises from the peripheral centriole at the end of the second spermatocyte division, just at the commencement of the formation of the acrosome (Figs. 63-66, D). As they reach the posterior position the two centrioles come to lie side by side, and the tail filament grows very greatly in length (Figs. 63-66, E, G).

Two other structures demand attention. Firstly the post-nuclear bodies which originate in an unknown way appear as small granules, staining in osmic in the late spermatocyte (Fig. 66, A). They are usually very near to the Golgi apparatus. An excellent account of their behaviour was given by Gatenby and Wigoder in 1929 (40). In the spermatid they have come to lie just behind the nucleus and far from the Golgi complex, which is by this time depositing the acrosome at the tip (Fig. 66, D, E). They are known in mammals, amphibians, molluscs, insects and annelids, and in all cases they expand until they form a strongly argentophil band at the posterior end of the elongating nucleus. This may be very large, as in the case of *Cavia cobaya* (Fig. 66, G).

The origin of these post-nuclear bodies is doubtful. Its first observed appearance by the Golgi apparatus, as also its ability to be stained by osmium and silver, suggests an origin from the Golgi apparatus, but its definite formation has not yet been seen. Gatenby and Wigoder attribute a supporting function for the delicate tail to it, and this it probably would have, but there is no evidence for this other than its position, and it has not been demonstrated that the body is any more rigid than the surrounding cytoplasm.

Finally we come to the recently-described vacuolar system. For a description of this system in spermatogenesis we are again indebted to Gatenby (35). He has described its behaviour in *Abraaxas*, *Helix* and *Cavia*. An account of this system in the spermatogenesis of *Saccocirrus* was also given by him much earlier before its identity was known (33).

In *Helix* the vacuoles stainable *intra vitam* in neutral red are found at first in the spermatocyte within the Golgi apparatus

(Fig. 63, A). They are set free, however, and perform no visible function, and eventually drift down the tail with the surplus protoplasm (Fig. 63, F, G).

In *Abraxas* and *Cavia* they are first found very near the Golgi apparatus, and possibly have been extruded from it (Figs. 65, 66, A). Throughout the divisions and subsequent spermateleosis they keep close to the Golgi apparatus, and even as the Golgi remnants drift down the tail the vacuoles can be seen in company with them (Figs. 65, 66, F, G).

They have been described as the Y-granules in *Saccocirrus* (33), with similar behaviour (Fig. 62, A). No function can be attributed to them as yet. They have also been observed by Voinov (131) and Hirschler (52, 53).

Oogenesis and Yolk Formation. Oogenesis, apart from the deposition of reserve products, is comparatively uneventful. This deposition occurs before the first oocyte division during the so-called growth period. Simultaneously the nucleus enlarges after synapsis, becomes very lightly staining, and is termed the germinal vesicle. This is a comparatively long period. The separation of three polar bodies by unequal division occurs finally. Fertilisation may occur at many stages of the maturation division, but a very remarkable case is reported in *Saccocirrus* (Gatenby), where it takes place before the germinal vesicle stage. By far the most interesting period of oogenesis is that of yolk formation, and to that we shall now turn.

Just as the formation of the acrosome by the Golgi apparatus in spermatogenesis proved to be a sure starting point for investigating the problems of the Golgi apparatus, so it was hoped that a study of vitellogenesis in oogenesis would lead to further light being thrown on the functions of the various cell organs. The whole matter has, however, proved to be of extraordinary complexity, so that there are few fields of cytology in which there is more confusion, and opinions are more hopelessly divided. The study of yolk formation has increased greatly during this decade, and a convenient starting point will be found in a paper by Gatenby and Woodger in 1920 (41), in which they summarise the position at that time.

Their review includes a description of the vitellogenesis of three

closely-related Mollusca, *Helix*, *Limnaea* and *Patella*. In the first two animals, the yolk is either derived from the cytoplasm, or else by a metamorphosis of the Golgi elements which are diffuse. In *Patella* the Golgi dictyosomes are found attached to the yolk spheres, and there does not seem much doubt that they are closely connected.

In amphibia and insects a distribution of the mitochondria to the periphery, where the yolk always appears, suggests a possible connection; but in the frog, where the mitochondria stain differentially to the yolk, no transitional forms have been found. Certainly in insects the yolk and the Golgi apparatus appear to be unconnected. The yolk here is possibly derived from the nucleoli (Hogden, *vide infra*).

In *Ascidia* the work of Hirschler (49) shows that yolk arises by growth of the mitochondria and subsequent fusion with the Golgi. (This is denied by Harvey, *vide infra*.) In embryonic cells the swollen mitochondria (*i.e.*, yolk) shrink back to their original size.

In *Ascaris*, yolk is derived by the swelling of the mitochondria. No contact with the Golgi apparatus is seen. Fat appears in the cytoplasm distinct from the rest of the inclusions.

The relationship between mitochondria and fat is gone into by Gatenby and Woodger, but there is little definite evidence except that the mitochondria can swell up to form fat (Schreiner, Murray and Dubreuil).

Gatenby explores the possibility that the archoplasm (= idio-plasm) associated with the Golgi elements may become loaded with leipins and fats under the action of the Golgi, and thus change into yolk (*vide, e.g., Patella, supra*).

Apart from these well-known inclusions, the relationship of the so-called yolk nuclei and chromidia required much further investigation, as the definitions given them show that they are not always homologous structures. Furthermore, the part played by the nucleolus, illustrated by the case of *Saccocirrus* (Gatenby), and insects (Hogben), was not correlated with the other cell activities.

It will be seen from this that practically all the known cell inclusions, including even the chromatin of the nucleus (crude technique had attributed a chromatin origin to many chromidia

probably of mitochondrial nature), were under suspicion as producers or auxiliaries in vitellogenesis. This, of course, is rightly so, but the whole case is vitiated by the fact that certain ones only are picked out in certain cases as the sole agents. The cases of *Ascaris* and *Patella* appear to be mutually incompatible.

Reference has been made above to the work of Hogben on the rôle of the nucleolus, and as a very important suggestion was made by him at that time, the outlines of his results must be briefly summarised (55-57).

Despite individual differences between *Periplaneta* and *Libellula*, it appeared that the nucleolus became differentiated into two phases. In *Periplaneta* these phases follow one after the other, in *Libellula* they occur simultaneously. From one phase (the first in *Periplaneta*, the cortical in *Libellula*) no permanent structures are derived, but from the other phase, vacuoles are emitted either many at a time (*Periplaneta*) or one only at a time (*Libellula*). These vacuoles pass out into the cytoplasm and there turn into yolk (deutoplasm). In *Libellula* they are often surrounded by mitochondria derived from the so-called yolk nucleus, and Hogben is led to suggest that the formation of yolk is due to the intricate interaction of the metabolic functions of plasmosome (active nucleolus), mitochondria and Golgi apparatus. This suggestion is of considerable value and appears to have been lost sight of by everyone until a reference is made to it by Harvey in 1929 (46). It will be seen from the summary of work on oogenesis set out below (pp. 148 *et seq.*) that no attempt has been made to follow up this suggestion and to test whether the facts can be interpreted on this basis.

Starting with the vertebrates, we know that the yolk contains proteins, fats and lipins, but in the invertebrates, although this is still true, there are other reserve materials present as distinct granules or spheres in the cytoplasm. These various substances Brambell considers are elaborated in different ways either directly or indirectly from the Golgi apparatus, or from mitochondria, from nucleolar material or again independently from the ground cytoplasm. He therefore considered that the term yolk (using the term generally for reserve materials) should always be qualified

by a reference to its composition and origin. As a matter of fact, the terminology suggested by him at the suggestion of Gatenby refers only to the origin, *i.e.*, Golgi yolk, nucleolar yolk, etc. This in our opinion is unsatisfactory, as it prejudices the case. Further, the only criteria which are more or less independent of personal observation and opinion are chemical ones and therefore refer to the composition of the yolk. This has apparently been found the case in practice, and the literature is confused by terms such as "true yolk" or "ordinary yolk," the former being used by Gatenby (33) for light fatty yolk in *Saccocirrus*, the latter by Bowen (11) to refer to heavy albuminous yolk in general. Brambell produces support for his suggestion by observations on *Helix* and *Patella*. In both these molluscs there are two types of reserve product; one is light (as shown by centrifuging experiments), fatty and produced by the Golgi apparatus (*vide* Gatenby above), the other is heavy, albuminous and formed by a swelling of the mitochondria. Differences between *Helix* and *Patella* consist in the fact that the fatty yolk is formed directly from the Golgi apparatus in *Helix*, but rather secreted by the Golgi in *Patella*. There are also differences in the proportions of the two types of yolk. He can find no evidence as to how the mitochondria swell up, whether by building up material themselves or by absorbing it from the cytoplasm. The metamorphosis of the Golgi rods in *Helix* is shown by all the intermediate conditions which he finds, and it is produced by a deposition of material within their own substance, presumably without loss of identity by the latter. This brings it more or less into line with *Patella*.

Bowen reviews the position in 1926 (11), and although few new facts had been produced, is inclined to the view that the whole situation was in a hopeless confusion. This attitude will probably be inevitable if too much weight is put upon the earlier workers' results, for, not merely improved technique, but also a general clarifying of ideas has taken place and more exact terminology is now possible, although it is not resorted to too often. Bowen suggests that there are two and only two kinds of yolk. Firstly fatty yolk; lipoidal in nature, blackened by osmic acid, light and oily and therefore easily found at the top of the egg after centri-

fusing; secondly more abundant (this is certainly not true in some cases, *e.g.*, *Patella*, *vide* Brambell, *supra*) heavy ordinary yolk (presumably albuminous in nature). The former he is inclined to associate in formation with the Golgi apparatus, while the latter he suggests is formed otherwise. (In justice to Bowen it should be pointed out that he is concerned chiefly with the Golgi apparatus, and that omissions of statements concerning other inclusions is due to this.)

The possible methods of yolk formation are practically as many as the number of workers. They can, however, be grouped into about two main groups. As a preliminary, it is necessary to point out that it is practically impossible to discuss work in which only one type of yolk in invertebrates is acknowledged. This holds particularly for the earlier workers who failed to distinguish between the fatty or lipoidal yolk and the albuminous or protein yolk. Their facts can, however, be taken as evidence that one or other type of yolk has been observed to be derived in a particular manner.

SUMMARY OF YOLK FORMATION

| | | | | | |
|-------------------------|---|------|-----------------------------------|---|--|
| Gatenby | . | 1919 | <i>Apanteles</i> | . | No fatty yolk. Albuminous yolk by interaction of mitochondria and secondary nuclei. |
| Hogben | . | 1920 | <i>Synergus</i> <i>Formica</i> | } | . Albuminous yolk probably from secondary nuclei from nucleolus. |
| „ | . | 1920 | <i>Periplaneta</i> | | |
| „ | . | 1920 | <i>Libellula</i> | . | Albuminous yolk from nucleolus by interaction of mitochondria and Golgi bodies. |
| Gatenby and Woodger. | . | 1920 | <i>Helix</i> | } | . Yolk from Golgi bodies or cytoplasm. |
| „ | . | 1920 | <i>Limnaea</i> | | |
| „ | . | 1920 | <i>Patella</i> | | |

| | | | | | | |
|-------------------|---|------|--|---|---|---|
| Brambell | . | 1924 | <i>Helix</i> | } | . | Fatty yolk from Golgi bodies. |
| „ | . | 1924 | <i>Patella</i> | | . | Albuminous yolk from mitochondria. |
| Ludford | . | 1922 | <i>Limnaea</i> | . | . | Nucleolar extrusions possibly related to yolk. |
| „ | . | 1921 | <i>Patella</i> | . | . | Fatty yolk from Golgi bodies. |
| | | | | | | Albuminous yolk from nucleolus. |
| Gatenby | . | 1922 | <i>Saccocirrus</i> | . | . | Fatty yolk from Golgi bodies. |
| | | | | | | Albuminous yolk from nucleolus. |
| Hirschler | . | 1918 | <i>Ciona</i> | . | . | Lipoidal matter contributed by Golgi bodies to swollen yolky mitochondria. |
| Harvey | . | 1927 | <i>Ciona</i> | . | . | Albuminous matter from Golgi bodies and lipoidal matter from test-cells compounded by the mitochondria. |
| „ | . | 1929 | <i>Carcinus</i> | . | . | Fatty yolk material from nucleolus and cytoplasm. |
| | | | | | | Albuminous yolk from Golgi bodies. |
| „ | . | 1925 | <i>Lumbricus</i> | . | . | Yolk from cytoplasm. |
| Gatenby and Nath. | . | 1925 | <i>Lumbricus</i> | . | . | No yolk present. |
| Nath | . | 1925 | <i>Scorpions</i> | | . | Fatty yolk from Golgi bodies. |
| | | | (<i>Euscorpius</i> , <i>Buthus</i> and <i>Palamnaeus</i>). | | | Albuminous yolk (when present) from nucleolus. (When albuminous yolk absent, no nucleolar extrusions.) |

- Nath . . . 1928 *Crossopriza* . Fatty yolk from Golgi vacuoles.
Albuminous yolk from cytoplasm.
- Nath and 1928 *Otostigmus* . Fatty yolk from Golgi
Husain. Albuminous yolk from cytoplasm or nucleolus.
- Nath and 1929 *Luciola* . Fatty yolk from Golgi
Mehta Albuminous yolk from nucleolus.
- Nath and 1929 *Periplaneta* . Fatty yolk from Golgi
Mohan. Albuminous yolk from nucleolus.
- Nath . . . 1924 *Lithobius* . Fatty yolk from Golgi vacuoles.
Albuminous yolk, probably from nucleolus, but not directly.
- King . . . 1924 *Lithobius* . Fatty yolk Golgi bodies (probably).
Albuminous yolk from nucleolus.
- Weiner . . . 1925 *Lithobius* . Fatty yolk from cytoplasm.
Albuminous yolk from Golgi bodies.
- Koch . . . 1925 *Lithobius* . Fatty yolk from yolk nucleus.
Albuminous yolk from cytoplasm.
- King . . . 1926 *Peripatopsis* . Fatty yolk, possibly from Golgi (not certain).
Nucleolar budding also occurs probably.

| | | | | |
|----------------|------|----------------------|---|---|
| King . . . | 1926 | <i>Oniscus</i> | . | Fatty yolk from Golgi bodies. Albuminous yolk from mitochondria. |
| Gardiner . . . | 1927 | <i>Limulus</i> | . | Nucleolar extrusions. Yolk as result of interaction of Golgi, mitochondria, nucleolar material and cytoplasm. |
| Gresson . . . | 1929 | <i>Tenthredinida</i> | . | Fatty yolk from Golgi vacuoles. Albuminous yolk from nucleolus. |
| Hibbard . . . | 1928 | <i>Discoglossus</i> | . | Fat (fatty yolk ?) independent origin . Yolk from vacuoles (Golgi vacuoles ?) |
| Spaul . . . | 1922 | <i>Nepa</i> | . | Albuminous yolk from nucleolus. |
| Stoepoe . . . | 1926 | <i>Nepa</i> | . | Albuminous yolk from Golgi bodies. |
| Wheeler . . . | 1924 | <i>Pleuronectes</i> | . | Yolk intimate with Golgi bodies. |
| Weiner . . . | 1925 | <i>Tegenaria</i> | . | Fatty yolk from vitelline layer. Albuminous yolk from Golgi bodies. |
| Voinov . . . | 1925 | <i>Gryllotalpa</i> | . | Fatty yolk from part of Golgi bodies. |

First let us consider the question of the fatty or lipoidal yolk. A great many of the observations summarised in the Table show that there is a considerable body of opinion supporting the belief that the fatty yolk is derived from the Golgi bodies. It will be found that Gatenby and Woodger, Gatenby, Brambell, Ludford, King and Nath are all of this opinion.

Their investigations, further, are spread over a considerable

range of the invertebrate animal kingdom (Mollusca, *Saccocirrus*, Scorpions, Spiders, Insects, Myriapods, *Oniscus*). It must be said in criticism, however, that there is a considerable degree of difference between these authors on the exact method of elaboration of the fatty yolk spheres. To quote examples of this, the spheres may be apparently secreted by the Golgi rods, the latter remaining on the outside of the spheres (Gatenby and Woodger in *Patella* (41), Ludford in *Patella* (74)); on the other hand the Golgi bodies may swell and so be metamorphosed into yolk, having the fatty substances deposited within them (Brambell in *Helix* (15), Nath and collaborators in Scorpions (96, etc.), etc.). A further complication arises in this connection because Nath has adopted Parat's views as regards the "vacuome" and Golgi apparatus. He therefore refers to the neutral red staining vacuoles as Golgi bodies, and that these swell and fill with fatty substance. Gatenby has shown (35) that although these vacuoles may be associated with the Golgi apparatus and may therefore be present in the idiosome (so that Nath's results would coincide with the first type of fatty yolk formation by Golgi), the vacuoles may have no intimate relationship with the Golgi bodies by the time fat is being deposited in them. Nath is therefore possibly (but not probably) examining some other cytoplasmic inclusion.

Turning now to the second group of opinions, we find that the only point in common between them is that they all agree that fatty yolk is *not* formed by or from the Golgi bodies. Instead, cytoplasm (Weiner in *Lithobius*), cytoplasm and nucleolus (Harvey in *Carcinus*), material from test-cells compounded by mitochondria (Harvey in *Ciona*), "yolk nucleus" (Koch), vitelline layer of cytoplasm (Weiner on *Tegenaria*) are all invoked in turn as sources or instruments to form the fatty yolk.

It will thus be seen that there is no opinion on the matter which can be mentioned as generally accepted.

With regard to the albuminous or proteid yolk there is more general accordance in some ways, although here again there is a strong minority. Starting with Hogben (on *Periplaneta*, *Synergus*, *Formicus* and *Libellula*), who found that nucleolar extrusions were intimately related with the formation of albuminous yolk, others

have followed, notably Gatenby (on *Saccocirrus*), Ludford (*Limnæa* and *Patella*), Nath and collaborators (Scorpions, *Lithobius*, *Luciola*, and *Periplaneta*). King (on *Lithobius*), Gresson (on *Tenthredinidæ*), Spaul (on *Nepa*). There are, however, two distinct views contained here, for several workers believe the extrusions to be directly metamorphosed into yolk while other workers (or the same workers on different material) conceive of an indirect relationship. In the minority we find Brambell (on *Patella*) and King (*Oniscus*) finding the mitochondria swelling up to form protein yolk; Weiner (on *Lithobius* and *Tegegnaria*) and Stoepoe (*Nepa*) derive this yolk from the Golgi bodies, as does Harvey also (on *Ciona* (indirectly) and *Carcinus*). Nath finds the cytoplasm the source of albuminous yolk in Spiders and Koch does the same in *Lithobius*.

Thus in regard to the formation and source of the albuminous yolk, no general statement can be made.

There are only a few cases in which comparisons can be made between different sets of observations on the same material. This does tend to eliminate the personal bias to a certain extent, although workers in the same school of thought are liable to the criticism of having the same preconceived ideas.

Comparisons in the case of the Mollusca, *Helix*, *Limnæa* and *Patella* show that there is quite a considerable amount of difference of opinion at any rate concerning the origin of the albuminous yolk. The four workers on *Lithobius* show wide divergencies as to the processes involved. Even Nath and King differ over the origin of the albuminous yolk (rather more than the summary indicates; *vide* Addendum to King's paper (69)).

Summarising, it would appear that no definite conclusion can be come to at the present time. It does not apparently assist matters to say that the majority of workers are of the opinion that the fatty yolk is produced by the Golgi bodies and the albuminous yolk derived from the nucleolar extrusions. The weight of evidence produced by other workers is sufficient for us at least to conclude that that is not the whole story.

To return to the suggestion of Hogben's referred to above, that the yolk is probably produced by an interaction of the various

cell inclusions and components, seems to us to be the most acceptable working hypothesis. The degree to which one particular cell organ may contribute will doubtless vary, inasmuch as the exact chemical nature of the yolk, both fatty and albuminous, may vary in different animals. The relative amounts of fatty and albuminous yolks has been shown to differ considerably in *Helix* (fatty yolk 10 per cent., albuminous yolk 50 per cent.) and *Patella* (fatty yolk 75 per cent., albuminous yolk 10 per cent.) by Brambell (15). Nath has shown that of three genera of scorpions, two (*Euscorpius* and *Buthus*) have albuminous yolk, and the fatty yolk contains no free fat and one (*Palaemnæus*) has no albuminous yolk, and the fatty yolk contains free fat. Such differences are amply sufficient to produce appearances which will lead to incorrect interpretations being put upon the processes examined.

A complete elucidation of these problems is evidently very far off, but it seems to us that this is a likely line of attack now that microchemical technique has become more exact and correspondingly useful.

MISCELLANEOUS

Protozoa. The most outstanding morphological discovery in the Protozoa is that of the neuromotor system. This was originally described by Sharp in *Diplodinium ecaudatum* as early as 1914 (116). But it was not until 1920 that an experimental demonstration was given by Taylor (124) of its true nature and function. Since then many workers (chiefly at the University of California), such as McDonald (82), Rees (115), Campbell (18, 19), Pickard (111) and Visscher (129) have found similar systems in a large number of Ciliates belonging to widely divergent orders.

A striking feature is the great similarity in broad outline of these systems in the different forms. In general terms the neuromotor apparatus consists of a central "motorium" situated below the pharynx, from which radiate fibres to different parts of the cell, but most particularly to the membranelles and specialised ciliary structures. At the bases of such locomotor organs can be found the basal granules of the ciliary fibres, and to these are attached the "nerve fibres" from the motorium. Taken together,

the neurofibres and the motor-granules and fibres constitute the neuro-motor apparatus.

In *Diplodinium ecaudatum*, Sharp describes, besides the central

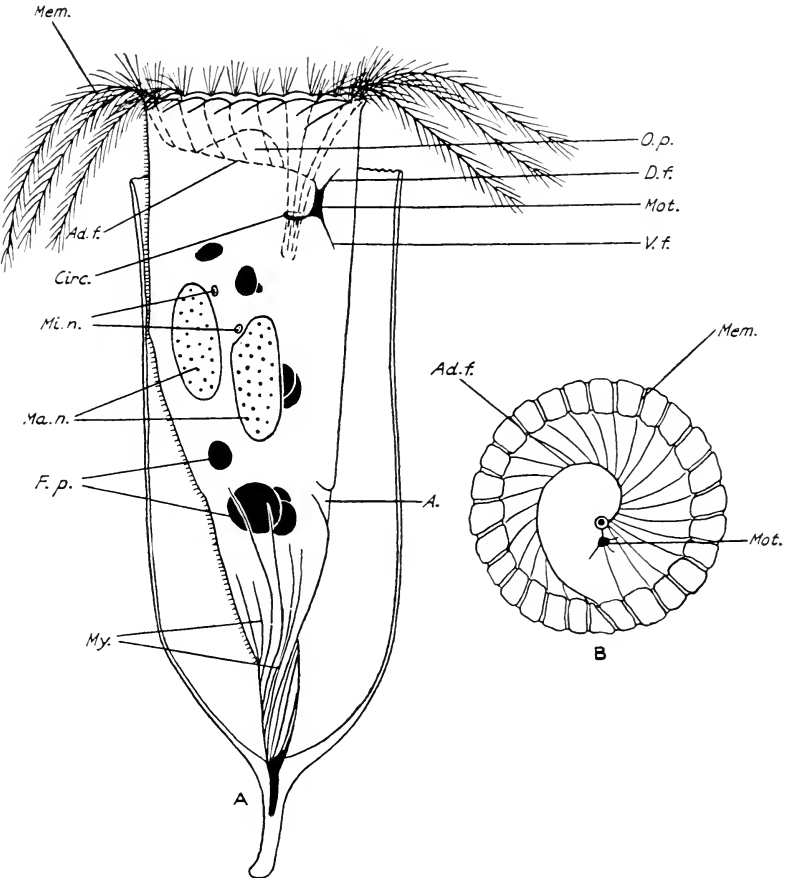

FIG. 67.—Diagram of the Neuromotor apparatus in *Favella* (after Campbell (19)). The membranelles have been omitted for the greater part on the near side in A. A, Side view. B, Oral view, showing the spiral adoral fibre. A., anus; Ad.f., adoral fibre; Circ., circumoesophageal ring; D.f., dorsal fibre; F.p., food-particles; Ma.n., macro-nucleus; Mi.n., micro-nucleus; Mem., membranelles; Mot., motorium; My., myonemes; O.p., oral plug; V.f., ventral fibres.

motorium, a circumœsophageal ring which appears to be another constant feature of the apparatus. This ring has fibres directed posteriorly to the wall of the gullet (Campbell (18)). Sharp also finds fibres to the dorsal membranelles and to the adoral membranelles. The operculum of *Diplodinium* also has special fibres. It was the structural relations of the various parts of this system with the motor organs that led Sharp to the conclusion that together they formed a neuro-motor apparatus.

Taylor found in *Euplotes* an admirable material for experimental investigation. Owing to the rigid pellicle surrounding the animal he was able to make incisions in the cell without causing a physical collapse. The neuro-fibres were further identifiable in the living organism both with and without the use of vital dyes. Having made a very complete study of the normal locomotion of this Ciliate, he was in a position to examine the effects of section of the neuro fibres with confidence. From his experiments there is no doubt that these fibres do act as a co-ordinating mechanism. Thus cutting the anal cirri fibres affects the creeping and swimming movements dependent upon the action of these cirri; destruction of the motorium and cutting the attached fibres interrupts the co-ordination of the movements of the locomotor organs, the membranelles and the cirri.

The conductive part of the system appears to consist, in those forms, so far studied of (1) the motorium, (2) the circumœsophageal ring, (3) dorsal and ventral fibres running to the ectoplasm beneath the cilia; the dorsal (or anterior) fibres appear to be the commoner and most strongly developed running to the peristomial region (Campbell (18)), (4) the adoral fibre which runs around the pharynx in a spiral and connects up with all the pharyngeal membranelles (Fig. 67). There are two of these in *Boveria teredinidi*, which has a very complicated system.

The only form differing widely from these is *Paramœcium*, which is a generalised form without any very special locomotor organs (115). It has a generalised neuro-fibrillar system consisting of a neuromotor centre (demonstrated with difficulty, but evidently corresponding to the motorium), from which radiate out two sets of fibres. Firstly two peripheral whorls, the larger

on the oral side and the other on the aboral side, probably correspond to the dorsal and ventral fibres; secondly cytopharyngeal fibres, an anterior set to the anterior zone of membranelles probably corresponding to the adoral fibres, and a posterior set to the posterior end of the pharynx. This last is evidently the generalised form of the circumœsophageal ring with its fibres to the gullet.

These discoveries in the Ciliata are of considerable importance, not only from the morphological point of view, but also in the consideration of behaviour and function in these highly organised Protozoa.

Several attempts have recently been made to establish the homologies of the constant cell inclusions of the Metazoa in the Protozoa. So far the results are not easy to harmonise, chiefly owing to the great differences of organisation found in the various classes of the Protozoa, and it is due also to the uncertainty of the specificity of Metazoan methods of demonstration in Protozoa.

The homology of the Golgi bodies is a case in point. Duboscq and Grassé have examined the so-called parabasal bodies of certain Flagellata, principally those Trichonymphids found in Termites in France (27, 28). They come to the conclusion that in appearance of structure these bodies resemble the Golgi bodies of metazoa. There is an elongated rod deeply impregnated by the classical Golgi methods of osmium and silver accompanied by an "idiosome" or chromophobe area on one side of it. When these methods are employed it is worthy of note that only the parabasal bodies are visible. The possibility of their being mitochondria is explored, but what are taken to be true mitochondria are seen at the same time by some methods as filamentous or granular particles. They suggest that the parabasal bodies are a source of energy (whether physical or chemical is not stated) which is utilised by the flagellæ.

Gatenby and King (37) have described bodies in *Opalina ranarum* which they compare both with the metazoan Golgi and with the parabasal bodies of the Flagellata. These are osmiophil and irregular in shape and lie at the base of the cilia, to whose filaments they appear attached. Their function may here be

similar to that of the parabasal bodies. King in *Anoplophrya basili* finds Golgi bodies consisting of distinct cavities in deeply staining substance (71). Although they have no connection with the cilia, King states that they are very like the bodies in *Opalina*. The mitochondria are evenly distributed and quite distinct. The homologies are, however, still considered doubtful. These "Golgi bodies" can be seen in living preparations stained in neutral red, and as we have shown previously, the vacuome is not always closely connected with the true Golgi apparatus (although it may be so in the Protozoa).

We are on safer ground in considering the results of Nassonov in ciliates and flagellates (91, 92). He has examined forms possessed of contractile vacuoles, and has described the osmiophil and argentophil substance found apposed to the wall of these vacuoles (and their contributory canals) as the Golgi apparatus (Fig. 58). Certainly the appearance of these structures is similar to the metazoan Golgi, particularly those in *Chilodon* and *Dogielleta* (Fig. 58, D, E), where the apparatus is not too close to the vacuole, but encircles it like a ring. Perhaps the most convincing evidence is that of function, for, granted that these bodies are not artefacts, then their relation to excretion is very similar to the relation of the metazoan Golgi apparatus to secretion. (A complete analysis of Nassonov's work is given in the section on the Function of the Golgi Apparatus.)

Mention has already been made of Horning's work on the mitochondria of Protozoa (59, etc.). Apart from the use of a specific dye for the identification of these inclusions, the main interest of his work undoubtedly lies in their relation to the food vacuoles of *Amæba*. Apparently the food particles are not surrounded by a watery vacuole when they are engulfed. These vacuoles appear only after mitochondria have adhered to the surface of the food particles. His observations that the mitochondria appear to be unable to pierce the vacuoles when once they have been formed cannot admit of any other plausible explanation. Observations *intra vitam* with a dye have thus a great advantage over other methods.

The peculiar distribution of these bodies also appears to be in

sight of explanation on the grounds of the action of phospholipins on surface tension. This is slightly outside the confines of microscopy, but it is very necessary to take as many facts into consideration as possible.

Cell Membranes. One of the problems which microscopists have to face is connected with the nature of the cell and nuclear walls. This question dates back to the discovery of the cell in plants when the cellulose wall which we know now as a secretion was regarded as the most important cellular structure. Similar mistakes have occurred in animal cytology, especially in connection with such specialised membranes as the vitelline membrane of the egg. We are concerned now, however, with the true protoplasmic wall.

The advent of the technique of micro-dissection has been used, chiefly by Chambers (21), to ascertain the nature of the restraining cell wall. By means of the very delicate apparatus employed, it is possible to touch delicately, puncture or tear the surface of various cells contained in hanging drops. All the results point to the fact that the cell wall is a definitely organised structure. This is not to say, of course, that it is possible of isolation. As a matter of fact, the reverse is the case. Its very organisation is dependent not only upon the external medium, but upon the condition of the protoplasm within. The chief proof of its organisation depends upon the results of its destruction. If a mammalian (non-nucleated) red blood corpuscle be punctured the hæmoglobin immediately begins to diffuse out over the whole surface of the cell; not merely at the point of puncture. The semi-permeability of this membrane has been destroyed *all over* by injury at one point. Again, if the ciliated cells of the ovary of the sea-urchin be punctured, disintegration of the cell wall takes place, commencing at the break and rapidly spreads all over. The progress of the degenerative process can be watched most successfully in the ciliated region, as the cilia ceases to beat as soon as the wall below has disintegrated. The time factor must not be neglected as evidence. Portions of cells can be torn away from cells (*Amœba*, Lewis, *vide* 21) without permanent injury provided that sufficient time is given for the surface film to organise itself. If,

on the other hand, the injury is violent and sudden, disintegration sets in rapidly before another surface film can form. The quickness with which the new film is formed varies according to the surrounding fluid. It is remarkably quick in the star-fish egg in hypertonic sea-water (Chambers, 21). Another factor is the condition of the protoplasm inside dependent upon external conditions or upon its own specificity.

Enough has been said to show that the cell wall cannot be expressed entirely in terms of an interfacial film, but that it possesses definite organisation and must be considered as a cell organ.

The results of Strangeways and Canti (122, 123) and others by dark-ground illumination show a slightly different picture. They state that there is no definite cell wall visible, although the outline is sufficiently distinct. This we think is not contradictory to Chamber's conception, because the organisation suggested is a chemical and physical one of really minute proportions, and there is no reason to suppose that optical differentiation of a sufficient magnitude is likely to occur.

A similar view is supported by the work of Gray on cell division. According to him the dividing cell wall is actually laid down *in situ*, *i.e.*, organises itself. Separation into two is a mechanical process subsequently carried out. If reference is made to the case of the spermatocyte division figures given by Bowen (4) when he refers to the cutting in two of the mitochondria, I think it is clear that a similar explanation will fit that case equally well (Fig. 64, C). Similarly, in the case of the nuclear-wall, all the evidence of microdissection workers shows that it has a definite organisation. Nearly all the experiments enumerated above on the cell wall have been paralleled in the case of the nuclear membrane with similar results.

Any advance in our knowledge in this direction is likely to come from the physiologist and from the biochemist. On the whole, the microscope has been used to its optical and manipulative limits.

Pathological Cytology. A really adequate treatment of this subject would require many more pages and more expenditure of

time on the part of the reader than could be demanded in a work of this nature. Some reference must, however, be made to the work which is being done in this direction. Summed up briefly, it may be said that the amount of information concerning the behaviour of cell constituents during the cell cycle in a very large number of pathological conditions is enormous, but that so far no outstanding co-ordinating facts can be produced.

A very comprehensive account of the cytology of cancer will be found in a paper by Ludford (80). A few examples will show how difficult it is to draw any general conclusions whatever. As regards the behaviour of the chromosomes during mitosis, all types of aberrations may be found from the normal behaviour (*e.g.*, squamous-cell sarcoma of the mouse) to pluripolar (carcinoma) and abortive (epithelioma) mitoses. Fig. 13, in the paper referred to above, summarises the many different phenomena met with.

Turning to the protoplasmic inclusions, we find the same divergence in the phenomena present. Considerable hypertrophy of the Golgi apparatus and mitochondria may occur as in hypertrophied cancer cells in the fibro-sarcoma of the rat. The extent to which this may be found varies even between different specimens of experimentally induced tar cancers on the same animal. Similarly, during mitosis the Golgi apparatus behaves in quite different ways (see Fig. 14, 80). Nucleolar extrusions take place in some cases (adeno-carcinoma of the mouse), but such conditions found in cancerous tissue cells can be also found in perfectly normal tissues.

Despite the considerable amount of data at his disposal, Ludford is compelled to come to the following general conclusions :—

“It has been pointed out that with our present microscopic technique there is no means of distinguishing between a normal and a cancerous cell. The wide range of pathological variations are the morphological expression of the reaction of the cells to the peculiar conditions of tumour growth. There is no pathological state restricted to cancer cells alone, so that there exists for the cancer cell no precise morphological diagnostic character of any kind.

“ . . . New methods of research will have to be devised, therefore, before we can explore cytologically the possibilities opened up by the work of these investigators (Gye and Barnard.)” (80, p. 290).

LITERATURE

1. AVEL, M. “Vacuome et appareil de Golgi chez les Vertébrés.” *C. R. Acad. Sci.*, T. 180, 1925.
- 1A. AVEL, M. “Appareil de Golgi et Vacuome.” *Bull. d'hist.*, T. 2, 1925.
- 1B. AVEL, M. “Sur les propriétés physiques de l'appareil de Golgi.” *C. R. Soc. Biol.*, T. 93, 1925.
2. BHANDARI, K. G. and NATH, V. “Studies in the Origin of Yolk. V. Oogenesis of the Red Cotton Bug *Dysdercus cingulatus*.” *Zeit. Zellf. mikr. Anat.*, Bd. 10, 1930.
3. BOWEN, R. H. “Studies in Insect Spermatogenesis. I. The History of the Cytoplasmic Components of the Sperm in Hemiptera.” *Biol. Bull.*, Vol. 39, 1920.
4. BOWEN, R. H. “Studies in Insect Spermatogenesis. II. The Components of the Spermatid and their Role in the Formation of the Sperm in the Hemiptera.” *J. Morph.*, Vol. 37, 1922.
5. BOWEN, R. H. “On Certain Features of Spermatogenesis in Amphibia and Insects.” *Amer. J. Anat.*, Vol. 30, 1922.
6. BOWEN, R. H. “On the Idiosome, Golgi Apparatus and Acrosome in the Male Germ Cells.” *Anat. Rec.*, Vol. 24, 1922.
7. BOWEN, R. H. “Studies in Insect Spermatogenesis. III. On the Structure of the Nebenkern in the Insect Spermatid, and the Origin of Nebenkern Patterns.” *Biol. Bull.*, Vol. 42, 1922.
8. BOWEN, R. H. “Studies in Insect Spermatogenesis. V. On the Formation of the Sperm in Lepidoptera.” *Quart. J. Micro. Sci.*, Vol. 66, 1922.
9. BOWEN, R. H. “On the Acrosome of the Animal Sperm.” *Anat. Rec.*, Vol. 28, 1924.
- 10A, B, C, D. BOWEN, R. H. “Studies on the Golgi Apparatus in Gland Cells.” Parts I, II, III, and IV. *Quart. J. Micro. Sci.*, Vol. 70, 1926.
11. BOWEN, R. H. “The Golgi Apparatus—its Structure and Functional Significance.” *Anat. Rec.*, Vol. 32, 1926.
12. BOWEN, R. H. “The Golgi Apparatus and Vacuome.” *Anat. Rec.*, Vol. 35, 1927.
- 13A, B. BOWEN, R. H. “The Methods for the Demonstration of the Golgi Apparatus.” “V. The Idiosomic Component, Lipoids, Trophosphonium, Lacuome and Chromidia.” “VI. Protozoa, Vacuome, Plant Tissue.” *Anat. Rec.*, Vol. 40, 1928.
14. BRAMBELL, F. W. R. “The Activity of the Golgi Apparatus in Neurons of *Helix aspersa*.” *J. Physiol.*, Vol. 57, 1923.
15. BRAMBELL, F. W. R. “The Nature and Origin of Yolk.” *Brit. Journ. Exper. Biol.*, Vol. 1, 1924.
16. BRAMBELL, F. W. R. “The Part played by the Golgi Apparatus in Secretion, and its subsequent Reformation in the Cells of the Oviducal Glands of the Fowl.” *J. R. Mier. Soc.*, 1925.
17. BRIDGES, C. B. “The translocation of a Section of Chromosome II, upon Chromosome III., in *Drosophila*.” *Anat. Rec.*, Vol. 24, 1923.
18. CAMPBELL, A. S. “The Cytology of *Tintinnopsis nucular* (Fol) Laackmann.” *Univ. Calif. Pub. Zool.*, Vol. 29, 1926.

19. CAMPBELL, A. S. "Studies in the Marine Ciliate *Favella* (Jorgensen), with special regard to the Neuromotor Apparatus, etc." *Univ. Calif. Pub. Zool.*, Vol. 29, 1927.
20. CANNON, H. G. "A Further Account of the Spermatogenesis of Lice." *Quart. J. Micro. Sci.*, Vol. 66, 1922.
21. CHAMBERS, R. "The Physical Structures of Protoplasm as determined by micro-dissection and injection." Chapter V. in Cowdry, E. V., "General Cytology," 1924.
22. COWDRY, E. V. "Cytological Constituents." Chapter VI. in Cowdry, E. V., "General Cytology, 1924."
23. CRAMER, W. and LUDFORD, R. J. "On Cellular Changes in Intestinal Fat Absorption." *J. Physiol.*, Vol. 60, 1925.
24. CRAMER, W. and LUDFORD, R. J. "On Cellular Activity and Cellular Structure as studied in the Thyroid Gland." *J. Physiol.*, Vol. 61, 1926.
25. CURRY, L. F. "A Cytological Study of the Proximal and Distal Tubules of the Mesonephros of *Necturus maculosus*." *J. Morph.*, Vol. 48, 1929.
26. DONCASTER, L., and CANNON, H. G. "On the Spermatogenesis of the Louse (*Pediculus corporis* and *P. capitis*)." *Quart. J. Micro. Sci.*, Vol. 64, 1920.
27. DUBOSCQ, O. and GRASSÉ, P. "Notes sur les protistes parasites des termites de France." *C. R. Soc. Biol.*, T. 90, 1924.
28. DUBOSCQ, O. and GRASSÉ, P. "L'appareil parabasal des flagellés et sa signification." *C. R. Acad. Sci.*, T. 180, 1925.
29. GARDINER, M. S. "Oogenesis in *Limulus polyphemus*, with special Reference to the Behaviour of the Nucleolus." *J. Morph.*, Vol. 44, 1927.
- 30A-I. GATENBY, J. B. "The Cytoplasmic Inclusions of the Germ Cells." "I. Lepidoptera." *Quart. J. Micro. Sci.*, Vol. 62, 1917. "II. *Helix aspersa*." *Ibid.*, Vol. 62, 1917. "III. Some other Pulmonates." *Ibid.*, Vol. 63, 1918. "IV. *Paludina*, *Testacella* and *Helix*." *Ibid.*, Vol. 63, 1919. "V. *Limnaea stagnalis*." *Ibid.*, Vol. 63, 1919. "VI. *Apanteles glomeratus*." *Ibid.*, Vol. 64, 1920. "VII. Modern Technique of Cytology." *Ibid.*, Vol. 64, 1920. "VIII. *Grantia compressa*." *Journ. Linnæan Soc.*, 1920. "IX. *Cavia*." *Quart. J. Micro. Sci.*, Vol. 65, 1921.
31. GATENBY, J. B. "On the Relationship between the Formation of Yolk and the Mitochondria and Golgi Apparatus during Oogenesis." *J. R. Micr. Soc.*, 1920.
32. GATENBY, J. B. "Further Notes in Oogenesis and Fertilisation in *Grantia compressa*." *J. R. Micr. Soc.*, 1920.
33. GATENBY, J. B. "The Gametogenesis of *Saccocirrus*." *Quart. J. Micro. Sci.*, Vol. 66, 1922.
34. GATENBY, J. B. "Further Notes on the Gametogenesis and Fertilisation of Sponges." *Quart. J. Micro. Sci.*, Vol. 71, 1927.
35. GATENBY, J. B. "Study of the Golgi Apparatus and Vacuolar System of *Cavia*, *Helix* and *Abraxas* by Intravital Methods." *Proc. Roy. Soc., London*, Vol. B. 104, 1929.
36. GATENBY, J. B. and KING, S. D. "Golgi Bodies in a Coccidian." *Quart. J. Micro. Sci.*, Vol. 67, 1923.
37. GATENBY, J. B. and KING, S. D. "Note on certain New Bodies in *Opalina ranarum* presumed to represent the Golgi Elements." *Quart. J. Micro. Sci.*, Vol. 70, 1926.
38. GATENBY, J. B. and MUKERJI, R. N. "The Spermatogenesis of *Lepisma domestica*." *Quart. J. Micro. Sci.*, Vol. 73, 1929.
39. GATENBY, J. B. and NATH, V. "The Oogenesis of certain Invertebrata with special reference to *Lumbricus*." *Quart. J. Micro. Sci.* Vol. 70, 1926.

40. GATENBY, J. B. and WIGODER, S. B. "The Post-nuclear Body in the Spermatogenesis of *Cavia cobaya* and other Animals." *Proc. Roy. Soc., London*, Vol. B. 104, 1929.
41. GATENBY, J. B., and WOODGER, J. H. "On the Relationship between the Formation of Yolk and Golgi Apparatus." *J. R. Micro. Soc.*, 1920.
42. GRESSON, R. A. R. "Nuclear Phenomena during Oogenesis in certain Tenthredinidæ." *Quart. J. Micro. Sci.*, Vol. 73, 1929.
43. GRESSON, R. A. R. "Yolk Formation in certain Tenthredinidæ." *Quart. J. Micro. Sci.*, Vol. 73, 1929.
44. HARVEY, L. A. "On the Relation of the Mitochondria and Golgi Apparatus to Yolk Formation, in the Egg Cells of the Common Earthworm, *Lumbricus terrestris*." *Quart. J. Micro. Sci.*, Vol. 69, 1925.
45. HARVEY, L. A. "The History of the Cytoplasmic Inclusions of the Egg of *Ciona intestinalis* (L.) during Oogenesis and Fertilisation." *Proc. Roy. Soc. London*, Vol. B. 101, 1927.
46. HARVEY, L. A. "The Oogenesis of *Carcinus moenas* Penn with special Reference to Yolk Formation." *Trans. Roy. Soc. Edinb.*, Vol. 56, Pt. 1, 1929.
47. HIBBARD, H. "Cytoplasmic Constituents in the Developing Egg of *Discoglossus pictus* O. H." *J. Morph.*, Vol. 45, 1928.
48. HIBBARD, H., and PARAT, M. "Oogenesis in Certain Teleosts." *J. Anat.* Vol. 61, 1927.
49. HIRSCHLER, J. "Ueber den Golgischen Apparat embryonaler Zellen." *Arch. mikr. Anat.*, Bd. 91. 1918.
50. HIRSCHLER, J. "Appareil de Golgi-vacuome au cours de la spermatogénèse chez *Macrothylacia*." *C. R. Soc. Biol.*, 1927.
51. HIRSCHLER, J. "Observations sur les spermatocytes des Mollusques après coloration vitale." *C. R. Soc. Biol.*, 1927.
52. HIRSCHLER, J. "Relations topographiques entre l'appareil de Golgi et la vacuome au cours de la spermatogénèse chez *Phalera* et *Dasychira*." *C. R. Soc. Biol.*, 1928.
53. HIRSCHLER, J. "Studien über die Plasmakomponenten (Golgi-apparat u.a.) an vitalgefärbten männlichen Geschlechtzellen einiger Tierarten." *Zeit. Zellf. mikr. Anat.*, Bd. 7, 1928.
54. HIRSCHLER, J. u. MONNÉ, L. "Studien über die Plasmakomponenten an vitalgefärbten männlicher Geschlechtzellen einiger Säger." *Zeit. Zellf. mikr. Anat.*, Bd. 7, 1928.
55. HOGBEN, L. T. "Studies in Synapsis. I. Oogenesis in Hymenoptera." *Proc. Roy. Soc. London*, Vol. B. 91, 1920.
56. HOGBEN, L. T. "Studies in Synapsis. II. Parallel Conjugation and the Prophase Complex in *Periplanata*, with special Reference to the Pre-meiotic Telophase." *Proc. Roy. Soc. London*, Vol. B. 91, 1920.
57. HOGBEN, L. T. "Studies in Synapsis. III. The Nuclear Organisation of the Germ Cells in *Libellula depressa*." *Proc. Roy. Soc. London*, Vol. B. 92, 1920.
58. HORNING, E. S. "Histological Observations in Pancreatic Secretions." *Aust. J. Exper. Biol. Med. Sci.*, Vol. 2, 1925.
59. HORNING, E. S. "Mitochondria of a Protozoan (*Opalina*) and their Behaviour during the Life Cycle." *Ibid.*, 1925.
60. HORNING, E. S. "Studies on the Mitochondria of *Paramæcium*." *Aust. J. Exper. Biol. Med. Sci.*, Vol. 3, 1926.
61. HORNING, E. S. "Observations on Mitochondria." *Ibid.*, 1926.
62. HORNING, E. S. "Mitochondrial Behaviour during the Life Cycle of *Nyctotherus cordiformis*." *Aust. J. Exper. Biol. Med. Sci.*, Vol. 4, 1927.
63. HORNING, E. S. "On the Relation of Mitochondria to the Nucleus." *Ibid.*, 1927.

64. HORNING, E. S. "On the Orientation of Mitochondria in the Surface Cytoplasm of Infusorians." *Ibid.*, 1927.
65. HORNING, E. S. "Studies on the Behaviour of Mitochondria within the Living Cell." *Aust. J. Exper. Biol. Med. Sci.*, Vol. 5, 1928.
66. HORNING, E. S. "Mitochondrial Behaviour during the Life Cycle of a Sporozoon (*Monocystis*)." *Quart. J. Micro. Sci.*, Vol. 73, 1929.
67. HORNING, E. S. "Studies in Mitochondria." *Aust. J. Exper. Biol. Med. Sci.*, Vol. 6, 1929.
68. KARPOVA, L. "Beobachtungen ueber den Apparat Golgi in Samenzellen von *Helix pomatia*." *Zeit. Zellf. mikr. Anat.*, Bd. 2, 1925.
69. KING, S. D. "Oogenesis of *Lithobius forficatus*." *Proc. Roy. Dublin Soc.*, Vol. 18, 1924.
70. KING, S. D. "Note on the Oogenesis of *Peripatopsis capensis*." *Quart. J. Micro. Sci.*, Vol. 70, 1926.
71. KING, S. D. "Note on the Cytology of *Anoplophrya basili*." *Quart. J. Micro. Sci.*, Vol. 70, 1926.
72. KING, S. D. "The Oogenesis in *Oniscus asellus*." *Proc. Roy. Soc. London*, Vol. B. 100, 1926.
73. KOCH, A. "Morphologie des Eiwachstams der Chilopoden." *Zeit. Zellf. mikr. Anat.*, Bd. 2, 1925.
74. LUDFORD, R. J. "Contributions to the Study of the Oogenesis of *Patella*." *J. R. Micr. Soc.*, 1921.
75. LUDFORD, R. J. "The Behaviour of the Nucleolus during Oogenesis with special Reference to the Mollusc, *Patella*." *J. R. Micr. Soc.*, 1921.
76. LUDFORD, R. J. "The Morphology and Physiology of the Nucleolus. The Nucleolus in the Germ Cell Cycle of the Mollusc *Limnea stagnalis*." *J. R. Micr. Soc.*, 1922.
77. LUDFORD, R. J. "The Distribution of the Cytoplasmic Organs in Transplantable Tumour Cells, with special Reference to Dictyokinesis." *Proc. Roy. Soc. London*, Vol. B. 97, 1924.
78. LUDFORD, R. J. "Cell Organs during Keratinisation in Normal and Malignant Growth." *Quart. J. Micro. Sci.*, Vol. 69, 1924.
79. LUDFORD, R. J. "Cell Organs during Secretion in the Epididymus." *Proc. Roy. Soc. London*, Vol. B. 98, 1925.
80. LUDFORD, R. J. "The General and Experimental Cytology of Cancer." *J. R. Micr. Soc.*, 1925.
81. LUDFORD, R. J. and CRAMER, W. "The Mechanism of Secretion in the Thyroid Gland." *Proc. Roy. Soc. London*, Vol. B. 104, 1928.
82. McDONALD, J. D. "On *Balantidium coli* and *B. suis* with an Account of their Neuro-motor Apparatus." *Univ. Calif. Pub. Zool.*, Vol. 20, 1922.
83. METZ, C. W. "Chromosome Studies in the Diptera. I. A Preliminary Survey of Five Different Types of Chromosome Groups in the Genus *Drosophila*." *J. Exp. Zool.*, Vol. 17, 1914.
84. METZ, C. W. "Observations on Spermatogenesis in *Drosophila*." *Zeit. Zellf. mikr. Anat.*, Bd. 4, 1926.
85. MONNÉ, L. "Observations sur les spermatocytes des Mollusques après coloration vitale." *C. R. Soc. Biol.*, 1927.
86. MULLER, H. J. "The First Cytological Demonstration of a Translocation in *Drosophila*." *Amer. Nat.*, Vol. 63, 1929.
87. MULLER, H. J. and ALTENBURG, E. "Chromosome Translocations produced by X-rays in *Drosophila*." *Anat. Rec.*, Vol. 41, 1928.
88. MULLER, H. J. and PAINTER, T. S. "The Cytological Expression of Changes in Gene Alignment produced by X-rays in *Drosophila*." *Amer. Nat.*, Vol. 63, 1929.
89. NASSONOV, D. "Das Golgische Binnennetz und Seine Beziehungen zu der Sekretion." *Arch. Mikr. Anat.*, Bd. 97, 1923.

90. NASSONOV, D. "Das Golgische Binnennetz und Seine Beziehungen zu der Sekretion." (Fortsetz). *Arch. Mikr. Anat.*, Bd. 100, 1924.
91. NASSONOV, D. "Der Exkretionsapparat der Protozoa als Homologen des Golgischen Apparats der Metazoazellen." *Arch. Mikr. Anat.*, Bd. 103, 1924.
92. NASSONOV, D. "Zur Frage ueber den Bau und die Bedeutung des lipriden Excretions-apparates bei Protozoa." *Zeit. Zelf. mikr. Anat.*, Bd. 2, 1925.
93. NATH, V. "Oogenesis of *Lithobius forficatus*." *Proc. Cambridge Phil. Soc.*, Vol. 1, 1924.
94. NATH, V. "Egg Follicle of *Culex*." *Quart. J. Micro. Sci.*, Vol. 69, 1924.
95. NATH, V. "Spermatogenesis of *Lithobius forficatus*." *Proc. Cambridge Phil. Soc. Biol. Sci.*, Vol. 1, 1925.
96. NATH, V. "Cell Inclusions in the Oogenesis of Scorpions." *Proc. Roy. Soc. London*, Vol. B. 98, 1925.
97. NATH, V. "The Golgi Origin of Fatty Yolk in the Light of Parat's Work." *Nature*, Vol. 118, 1926.
98. NATH, V. "On the Present Position of Mitochondria and the Golgi Apparatus." *Proc. Cambridge Phil. Soc. Biol. Sci.*, Vol. 2, 1926.
99. NATH, V. "Studies in the Origin of Yolk." "I. Oogenesis of the Spider *Crossopriza lyoni*." *Quart. J. Micro. Sci.*, Vol. 72, 1928.
100. NATH, V. and Husain, M. T. "Studies in the Origin of Yolk. II. Oogenesis of the Scolopendra, *Otostigmus Feae*." *Quart. J. Micro. Sci.*, Vol. 72, 1928.
101. NATH, V. and MEHTA, D. R. "Studies in the Origin of Yolk. III. Oogenesis of the Firefly *Luciola gorhami*." *Quart. J. Micro. Sci.*, Vol. 73, 1929.
102. NATH, V. and MOHAN, P. "Studies in the Origin of Yolk. IV. Oogenesis of *Periplanata americana*." *J. Morph.*, Vol. 48, 1929.
103. PAINTER, T. S. and MULLER, H. J. "Parallel Cytology and Genetics of Induced Translocations and Deletions in *Drosophila*." *J. Hered.*, Vol. 20, 1929.
104. PARAT, M. "Sur la constitution de l'appareil de Golgi et de l'idiosome ; vrais et faux dictyosomes." *C. R. Acad. Sci.*, T. 182, 1926.
- 104A. PARAT, M. "Evolution du vacuome au cours de l'évogénèse et de l'ontogénèse." *C. R. Ass. Anat.*, 1927.
105. PARAT, MARGUERITE. "La vacuome au cours de l'évogénèse et du développement de l'oursin *Paracentrotus lividus* LK." *C. R. Soc. Biol.*, T. 96, 1927.
106. PARAT, M. et PAINLEVÉ, J. "Constitution du cytoplasme d'une cellule glandulaire." *C. R. Acad. Sci.*, T. 179, 1924.
107. PARAT, M. et PAINLEVÉ, J. "Observation vitale d'une cellule glandulaire en activité." *Ibid.*, 1924.
108. PARAT, M. et PAINLEVÉ, J. "Appareil réticulaire interne de Golgi, trophosponge de Holmgren et vacuome." *Ibid.*, 1924.
109. PARAT, M. et PAINLEVE, J. "Sur l'exacte concordance des caractères du vacuome et de l'appareil de Golgi classique." *C. R. Acad. Sci.*, T. 80, 1925.
110. PATTEN, R., SCOTT, M. and GATENBY, J. B. "Cytoplasmic Inclusions of certain Plant Cells." *Quart. J. Micro. Sci.*, Vol. 72, 1928.
111. PICKARD, E. A. "The Neuro-motor Apparatus of *Boveria teredinidi* Nelson, a Ciliate from the Gills of *Teredo navalis*." *Univ. Calif. Pub. Zool.*, Vol. 29, 1927.
112. RAU, A. S. and BRAMBELL, F. W. R. "Staining Methods for the Demonstration of the Golgi Apparatus in Fresh Vertebrate and Invertebrate Material." *J. R. Micr. Soc.*, 1925.

113. RAU, A. S., BRAMBELL, F. W. R. and GATENBY, J. B. "Observation on the Golgi Bodies in the Living Cell." *Proc. Roy. Soc. London*, Vol. B. **97**, 1925.
114. RAU, A. S. and LUDFORD, R. J. "Variations in the Form of the Golgi Bodies during the Development of Neurones." *Quart. J. Micro. Sci.*, Vol. **69**, 1925.
115. REES, C. W. "The Neuro-motor Apparatus of *Paramœcium*." *Univ. Calif. Pub. Zool.*, Vol. **20**, 1922.
116. SHARP, R. G. "*Diplodinium ecaudatum* with an account of its Neuro-motor Apparatus." *Univ. Calif. Pub. Zool.*, Vol. **13**, 1914.
117. SPAUL, E. A. "The Gametogenesis of *Nepa cinerea*." *J. R. Micr. Soc.*, 1922.
118. STEOPOE, I. "L'appareil de Golgi dans la vitellogénèse chez la *Nepa cinerea*." *C. R. Soc. Biol.*, T. **94**, 1926.
119. STERN, C. "Eine neue Chromosomaberration von *Drosophila melanogaster*, und ihre Bedeutung für die theorie der linearen Anordnung der Gene." *Biol. Zbl.*, Bd. **46**, 1926.
120. STERN, C. "Über Chromosomenelimination bei der Taufliege." *Naturwissenschaften*, Bd. **15**, Heft **36**, 1927.
121. STERN, C. "Elimination von Autosomenteilen bei *Drosophila melanogaster*." *Zs. indukt. Abstamm-u. Vererb-Lehre*, Bd. **2**, 1927.
122. STRANGWAYS, T. S. P. "Observations on the Changes seen in Living Cells during Growth and Division." *Proc. Roy. Soc. London*, Vol. B. **94**, 1922.
123. STRANGWAYS, T. S. P. and CANTI, R. G. "The Living Cell *in vitro* as shown by Dark-ground Illumination, and the Changes induced in such Cells by fixing Reagents." *Quart. J. Micro. Sci.*, Vol. **71**, 1927.
124. TAYLOR, C. V. "Demonstration of the Function of the Neuro-motor Apparatus in *Euplotes* by the Method of Micro-dissection." *Univ. Calif. Pub. Zool.*, Vol. **19**, 1920.
125. WALKER, C. E. "The Meiotic Phase in Triton (*Molge vulgaris*)." *Proc. Roy. Soc. London*, Vol. B. **98**, 1925.
126. WALKER, C. E. and ALLEN, M. "On the Nature of Golgi Bodies in Fixed Material." *Proc. Roy. Soc. London*, Vol. B. **101**, 1927.
127. WEINER, P. "Contributions à l'étude des noyaux vitellins." *Arch. Russ. Anat. hist. emb.*, T. **4**, 1925.
128. WEINER, P. "Sur la résorption de graisses dans l'intestine." *Arch. Russ. anat. his embr.*, T. **5**, 1926.
129. VISSCHER, J. P. "A Neuro-motor Apparatus in the Ciliate *Dileptus gigas*." *J. Morph.*, Vol. **44**, 1927.
130. VOINOV, D. "Les éléments sexuelles de *Gryllotalpa vulgaris* (Latr.)." *Arch. Zool. exp. gen.*, T. **63**, 1925.
131. VOINOV, D. "Le vacuome et l'appareil de Golgi dans les cellules genitales males de *Notonecta glauca* (L.)." *Arch. Zool. Exper.*, 1927.

Section IV

BOTANY

By E. C. BARTON-WRIGHT, M.Sc.

Formerly Lecturer in Plant Physiology in University of Glasgow, and Lecturer in Botany in University of London, King's College, now Chief Assistant for Research in Virus Diseases of the Potato at the Scottish Society for Research in Plant Breeding, Corstorphine, Edinburgh.

THE GOLGI APPARATUS

TILL within recent times the Golgi apparatus, first discovered in 1898 by Golgi in the Purkinje cells of the barn owl's brain, was not convincingly shown to be present in plant cells. Definite evidence is now, however, forthcoming to show that the Golgi apparatus is also present in plant cells. Bowen has described in the male heads of *Polytrichum commune*, *P. juniperinum*, *P. filiferum*, in the root tips and growing points of *Equisetum arvense*, and also in the root tips of *Vicia faba*, *Pisum sativum* and other plants by the osmic acid impregnation method, certain bodies which he has named "osmiophilic platelets." These platelets are suspended in the hyaloplasm, and are never found within the vacuoles. They are disc-shaped and composed of osmiophilic material. A large number of such discs occur in each cell, though the number per cell varies enormously. They are relatively small in size, though size variation is exhibited. During mitosis there appears to be no orientation or division of the platelets, and it is apparently due to chance that an equal distribution leads to an approximately equal number of these bodies appearing in each daughter cell. The method of division of the platelets was not discovered, but possibly fragmentation may play a part. Bowen definitely advanced the opinion that these osmiophilic platelets

are related to the Golgi apparatus of insects, and represent the Golgi material of the plant cell.

Bowen also recognised two other systems of bodies, the “*plas-*

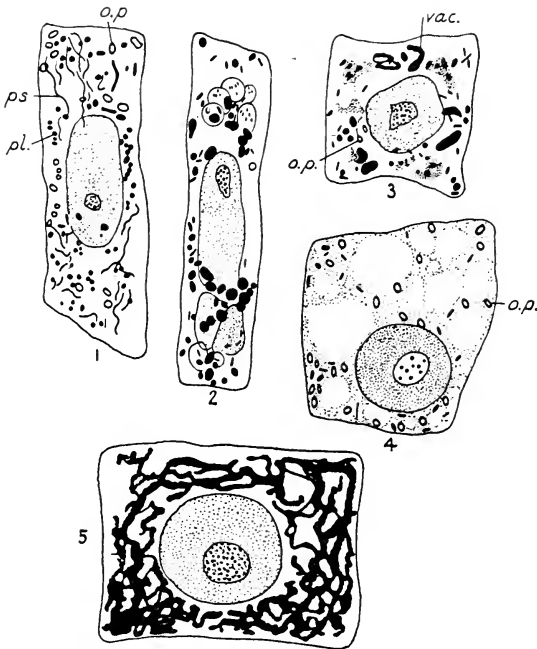

FIG. 68.—(1) and (2) cell from root-tip of *Vicia faba*, showing pseudochondriome (*ps.*) as densely blackened spherical granules and plastidome (*pl.*) as black dots, osmiophilic platelets (*op.*) as rings. (3) A network developed by fusion of primary vacuoles (*vac.*). (4) Osmiophilic platelets in *V. faba*. (5) Golgi reticulum in *V. faba*. (1), (2), (3) after Bowen, *Q. J. Micr. Sci.*; (4) after Patten, Scott and Gatenby, *Q. J. Micr. Sci.*; (5) after Scott, *Amer. J. Bot.*)

tidome” and the “*pseudochondriome.*” In undifferentiated cells the plastidome consists of distinctly elongated bodies which show a great variety of shape. The pseudochondriome, on the other hand, is characteristically spherical. Multiplication is apparently by simple fission, and at mitosis there is an equal distribution to the

daughter cells. The plastidome, the individual bodies of which are termed "*archiplasts*," unlike the pseudochondriome, passes through a definite series of changes connected intimately with the nuclear division figure, differing thereby from the pseudochondriomes, which are merely scattered throughout the cytoplasm. Bowen was unable to discover the function of these bodies and which of them represents the animal chondriome. Later, however, he ascertained that in the root tips and growing point of *Equisetum arvense*, the plastidome system is apparently entirely concerned with the formation of plastids, while the pseudo-chondriome has nothing to do with plastid formation. The plastidome system of the meristematic cells is elongated in shape and the chloroplasts and leucoplasts are gradually differentiated from them. It will be remembered that the pseudo-chondriome system is characteristically spherical in shape, and has apparently no function. From the very constant differentiation in staining capacity, morphology and structure, these bodies seem to belong to two totally different categories of cytoplasmic inclusions.

Patten, Scott and Gatenby, using the Kolatchev technique on the root tips of *Vicia faba*, have in large measure confirmed Bowen's findings. In the root tips of this plant, as well as in the shoot of *Pisum sativum* and the root tips of *Hyacinthus*, they found cells with only mitochondria, and others with osmiophilic platelets alone. The platelets were by far the commonest cytoplasmic inclusions revealed by the Golgi osmic methods. These platelets are very small, but in good preparations they impregnate clearly on a yellowish protoplasmic background. When seen edgewise, they appear as a black line. Observed flatwise, they are found to possess an osmiophile cortex and a central chromophobe medulla. They rarely form chains, and do not unite when close together. The platelets are very uniform in size, and are not moved by centrifuging. Patten, Scott and Gatenby claimed that the platelets closely resemble the Golgi bodies of the Hemiptera among animals.

Scott has also discovered Golgi bodies to be present in the root tip of *Vicia faba*. The material was fixed in Bensley's fluid, and it was discovered that the Golgi apparatus only made its appearance

after forty-eight hours' fixation. It may be on this account that the presence of the reticulum had not been observed in plant cells by previous investigators. The Golgi apparatus is more or less definitely localised in position. It is abundant in periblem and dermatogen, and also in the youngest layers of the calyptrogen. Mitosis is active in this region, and the Golgi reticulum persists throughout nuclear division. In the remaining tissue of the root tip, *i.e.*, the central plerome strand, in which the cells are already beginning to elongate and vacuolate, the Golgi network is absent. When secondary rootlet formation is about to occur, the Golgi apparatus disappears from the cells of the primary root tissue, but by the time that the secondary roots are $\frac{1}{2}$ to 1 cm. long, the Golgi network reappears in the primary dermatogen and periblem. In the meanwhile, the dermatogen and periblem of the root initials become possessed of the Golgi reticulum. In the tertiary rootlets the Golgi network is well marked. In the phase of primary root growth, during which the Golgi apparatus is absent from the meristematic cells, the cytoplasm of these cells, though devoid of a distinctly blackened network, is not homogeneous. A colourless system of canals ramifies through it, and from its appearance, colourless, in contrast with the blackened network of the secondary roots of the same axis, it may be concluded that the development, or at least the maintenance, of a canalicular system is independent of the usual canal contents. In other words, the usual osmic-reducing substances, proteins, lipoids and fats are absent. The accumulation of water from the condensation of amino-acids during protein synthesis is suggested as a possible origin of the Golgi apparatus in plant cells by this author.

MITOCHONDRIA

Mitochondria or chondriosomes are small granules, globules, rods, or sometimes thread-like structures, which are always to be found in the cytoplasm. Their presence has led to endless discussion as to their nature and function in the living cell. The most usual view, as far as the higher plants are concerned, is that they are primarily concerned with the formation of the chloro-

plasts. For a description of the recent papers on this aspect of the problem, see Barton-Wright, "Recent Advances in Plant Physiology."

As well as their probable function of plastid formation, a number of other views have been put forward with regard to their activity in the cell, and some of the more important of these will now be discussed.

According to Marston, from the reactions of mitochondria to azine dyes, these bodies contain proteolytic enzymes, and he came to the conclusion from the rapidity with which synthetic processes occur in the living cell, that the mitochondria are the site of enzymatic synthesis in the cell. Robertson held that the presence of lipoid material in these bodies would cause molecules to be orientated at the surface in such a manner that the reactive groups (carboxyl and amino-acid) would point to the external aqueous phase, and so be effectively concentrated at the phase boundary of mitochondrion and cytoplasm. According to both de Nouy and Cowdry, mitochondrial substance is arranged in such a manner as to give a surface film of maximum extent with the minimum of material, and such a local concentration would furnish an explanation of the facility with which enzymatic synthesis would take place at the surface of these bodies in the cell.

Horning and Petrie have investigated the influence of mitochondria on starch grains present in the endosperm of cereals. The types used were Red Hogan maize, Warden wheat and Cape barley. Hand-stained sections were prepared and stained in Janus Green B (1 in 8,000). This dye was found to be excellent for the purpose of rendering the mitochondria visible. The material was also fixed in osmo-chromic fluid and Cox's fixative.

It is a well-known fact that in maize the endosperm is packed with starch grains, and that at the onset of germination the finely-granulated cytoplasm of the epithelial cells of the scutellum becomes coarser in structure and this granulation increases in amount, following on the erosion of the starch grains in the endosperm cells adjacent to the epithelial cells bounding the scutellum. The hydrolysed products of the endosperm cells are absorbed by the epithelium, and are then passed on to the embryo and used in germina-

tion. Considerable changes now occur in the scutellum : the cells elongate and increase in size, there is also considerable crushing of the depleted endosperm cells, and the elongated cells of the scutellum may form themselves into hypha-like growths which invade the endosperm.

Horning and Petrie also studied the behaviour of the mitochondria in the resting grain in both scutellum and endosperm. They were found to be present in moderate amount in the epithelial cells and other cells of the scutellum, and were but sparsely distributed in the endosperm. The material was examined three days after the onset of germination, when the endosperm cells immediately adjacent to the scutellum had begun to show signs of depletion. In the meantime the epithelial cells, as well as the rest of the cells of the scutellum, had greatly increased in size, causing considerable crushing of the depleted cells of the endosperm. The scutellum now showed a great profusion of mitochondrial bodies, which were located in all the cells of the scutellum and epithelium. These bodies were found to be clustered in particularly large numbers round the outer walls of many of the epithelial cells, often appearing to be partly embedded in the cell wall itself. Horning and Petrie suggested that this feature shows that the mitochondria have actually passed through the epithelial layer into the endosperm. Presumably the mitochondria arise in the epithelium by repeated division. Six days after germination had commenced, they were found to extend well into the endosperm cells adjacent to the epithelium which were in the process of undergoing depletion of their starch content. Numbers of these mitochondrial bodies clustered round the walls of the endosperm cells, and in many cases they were actually found to be surrounding the grains themselves. Starch grains enclustered in this manner were always discovered to be in an advanced stage of erosion, while those which were not so far corroded invariably had fewer chondriosomes surrounding them. Horning and Petrie considered that some of the mitochondrial bodies present in the endosperm were certainly formed *in situ*, but that this supply was continuously being supplemented by an active process of secretion from within the epithe-

lium. They suggested that diastase is secreted from the scutellum in association with the mitochondria, and that in this manner the enzyme is brought into contact with the starch grains, and that active hydrolysis ensues.

Although mitochondria were also found to be present in the aleurone layer of the grains, no evidence was found for their migration from this region into the endosperm cells. Examination of the isolated endosperm mounted in "plaster of Paris" pillars immersed in water showed that in sixteen days the number of mitochondria was distinctly greater than in the dormant grain. They occurred in clumps scattered throughout the cells, and were also observed in the elongated form and in process of fission. It is therefore evident that mitochondria can increase in the endospermal region without active secretion supplementing the supply from the epithelial layer and scutellum. The rate of hydrolysis, however, in the isolated endosperm was very much less without secretion from the scutellum. Similar results were obtained in barley and wheat, but in these cases there was also a simultaneous secretion of a cytohydrolytic enzyme which dissolved the walls of the endosperm cells prior to the hydrolysis of the starch grains.

It is feasible that mitochondria should be able to migrate through the plasma-membrane. Cowdry, for example, has concluded that mitochondria are for the most part phosphatides in composition, together with the addition of a small amount of protein, and there is sufficient evidence to show that fatty substances of various kinds pass from apical meristems, where they are synthesised, into external differentiating cells, in the course of which translocation through numerous cell walls must occur.

The Vacuome

The presence of vacuoles filled with cell sap is a well-known fact in plant cells. These vacuoles differ in size in different cells. In meristematic tissues they are small and numerous, and as these cells grow and differentiate, they increase greatly in size and coalesce. The vacuolar system of a cell, whether there be a single or many vacuoles, has been termed by Dangeard the "*vacuome*."

The origin of the vacuolar system, or vacuome of cells has

led to much controversy. The older idea, due to von Mohl and others, claimed that they arose *de novo* in the cell. But as far back as 1885, de Vries disagreed with this view, and advanced the opinion that vacuoles were formed from certain bodies, to which he gave the name "tonoplasts." To settle these conflicting opinions, Pfeffer put the matter to experimental test. He introduced a crystal of asparagine into the plasmodium of myxomycetes and found that membranes were formed round the resulting droplets. He concluded from the results of his work that vacuoles could arise *de novo* in the cell. Pfeffer's views about this matter were very generally accepted up to recent times. Dangeard, however, advanced the theory that the vacuolar system of the cell, or as they preferred to term it, the *vacuome*, is a permanent constituent of the cell. This view has been enthusiastically supported by Guilliermond.

These workers have found in the Cyanophyceæ and bacteria certain corpuscles which stain deeply with basic aniline dyes. Similar bodies were also discovered in the fungi, and they were always to be located in the vacuole. These corpuscles, termed by Dangeard "metachromes," or "metachromatic corpuscles," are supposed to result from the precipitation of the normal colloidal constituents of vacuoles by intravital dyes, and they are therefore thought to exist in the vacuole of the living cell in the sol state. In the growing tips of the hyphæ of either *Saprolegnia* or *Mucor*, Dangeard observed that vacuoles first made their appearance as small beads or grains which were to begin with, somewhat isolated, and also as threads which later fused together to form a network. These bodies closely resemble mitochondria, and are composed of a thick metachromatin fluid or solution which stains readily with cresyl blue. With the ageing of the hyphæ, these thread-like bodies swell as the metachromatin solution absorbs water and become conspicuous vacuoles, which eventually fuse to form larger vacuoles. In the flowering plants, Dangeard found in the vacuoles a certain substance which he claimed to be closely related to metachromatin. This was thrown out of colloidal solution by the action of intravital stains, taking the form of deeply stained, rapidly moving corpuscles in the vacuoles, the bulk of

the vacuolar contents in the meanwhile staining slightly, or not at all. It was thought that the vacuoles in the meristematic regions arose by the hydration and swelling of numerous small mitochondria-like bodies containing a thick solution of metachromatin. As the cells of these regions proceed to differentiate, these corpuscles swell into small round vacuoles, which eventually fuse into a single large vacuole.

Guilliermond claimed to have confirmed these results for the yeasts and various ascomycetes (*Penicillium*, *Endomyces Magnusii*, and others). Neutral red was found to be the best stain, and gave

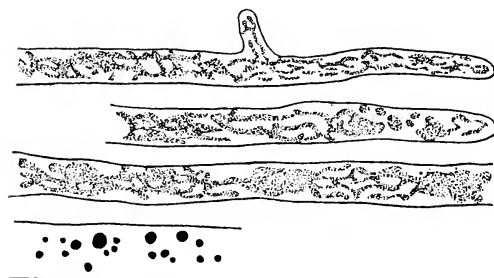

FIG. 69.—Hyphæ of *Saprolegnia* stained with neutral red. The vacuome shows as a network in the three upper figures, whilst in the lowest it can be seen as a vacuolar canal in which the neutral red has thrown down deeply staining corpuscles. (After Guilliermond, *Amer. J. Bot.*)

very much clearer results than cresyl blue. This worker came to the conclusion that in the majority of the fungi the vacuome originated at the hyphal tips as small grains, which showed at first a very uniform staining with neutral red. Further away from the tips these grains began to swell

and gradually formed minute vacuoles, in each of which metachromatin was precipitated by the neutral red as a small red grain which exhibited marked Brownian movement. In the older hyphæ these vacuoles fuse to form larger vacuoles, in which the metachromatin particles may be numerous. It was only in the cases of *Saprolegnia* and *Mucor* that the filiform and reticulate vacuoles described by Dangeard were discovered. Guilliermond was of the opinion that the vacuome was absolutely distinct from the chondriosome, for the vacuome absorbs intravital dyes more quickly, while, on the other hand, the chondriosome is stained neither by cresyl blue nor by neutral red. Apparently in the meristematic regions of the higher plants the colloidal matter in the vacuoles is

not metachromatin, and has no properties in common with this substance, beyond the fact of affinity for intravital dyes. The colloidal substances in the vacuoles of flowering plants differ widely in different cases, but they are for the most part composed of alcohol-soluble proteins, tannins and anthocyanins. In maturing seeds the vacuoles are alleged to be changed into aleurone grains. These vacuoles, which are at first composed of a weak solution of colloidal protein, are then dehydrated and break down into smaller vacuoles, and these ultimately shrink into small solid protein or aleurone grains. At the onset of germination the reverse changes occur: the grains absorb water, swell into small vacuoles, and finally fuse and form larger vacuoles. Unlike Dangeard, however, Guilliermond held the opinion that in certain cases vacuoles may and do arise *de novo*. He also put forward the suggestion that the Golgi apparatus of the animal cytologist and the Holmgren canals are two pictures demonstrated by different techniques, the one a negative and the other a positive of the same cell structure, which is actually the vacuome demonstrated in the living cells of plants with his neutral red technique.

THE STRUCTURE OF CHROMOSOMES

A number of contentious points are involved in a discussion of this nature. The question of correct fixation of material plays a very important part, and no doubt the various views that have been put forward from time to time are due to the fact that different workers have employed varying methods of fixation. Nuclei with large chromosomes have been principally investigated with regard to structure, and it is mainly with these that the following discussion is concerned.

At the prophase of mitosis the reticulum breaks down into the long slender thread of the spireme and the longitudinal split is first observed. The origin of this split is still a matter of controversy. According to Farmer, Digby, Fraser, Newton and others, it arises in the previous telophase, whereas according to Sharp there is no longitudinal split at telophase, but only alveolation of the chromosomes to form the reticulum of the new nucleus. Sharp observed the presence of alveoles or achromatic areas in the

telephasic chromosomes of *Vicia* and *Tradescantia*, which enlarge and coalesce to form a more or less continuous achromatic matrix. This process involves the assumption of a reticulate form of the chromatic karyotin.

Another view of the matter is the so-called *chromonema* hypothesis. Bonnevie, one of the principal supporters of this theory, considered that each chromosome at telophase differentiates into an endogenous spiral thread, which persists through interphase and emerges from the chromosomes at the following prophase as a slender filament which later splits. On this view the achromatic material is not continuous from one nuclear generation to another, but is differentiated anew at each telophase as the spiral develops and the term "*chromonema*" is given to the spiral filament. The achromatic portion swells and becomes the karyolymph, at the periphery of which, the nuclear membrane is laid down, while the spiral filament or chromonema persists as a definite structure throughout most or all of the nuclear cycle, and is not a temporary structure concerned with the split at prophase of mitosis.

This view has been further extended by Kaufmann, working with *Tradescantia pilosa*. He found that at anaphase in the nuclei of this species, the chromosome is made up of two morphologically dissimilar substances, achromatic and chromatic. The chromatic portion occurs as a pair of unbroken intertwined spiral threads, whereas the achromatic portion serves as a matrix for the chromatic material. At the inception of telophase, the achromatic material becomes continuous with the nuclear sap and the chromatic part of the chromosome maintains the genetic continuity of the chromosome. At early prophase the chromonemata (spiral portions) can be seen as a single thread spirally coiled, or as distinct intertwined threads. With the further onset of prophase, chromomere-like swellings make their appearance on the thread, and each of these forms a centre of activity in the formation of new chromonemata. At metaphase, when the chromosomes reach the equator of the spindle, each individual chromosome can be seen to consist of spiral parallel threads showing both chromatic and achromatic material, the former being clearly seen as a pair of spiral threads which become particularly clear at anaphase.

A somewhat different interpretation of the chromatic filament has been suggested by Martens. In his investigations on *Paris quadrifolia* and *Listera ovata*, the chromosomes were observed throughout the whole cycle of change, and the claim was made that two morphologically distinct portions are concerned in their structure, (1) a homogeneous achromatic matrix, which is distinct from the nuclear sap, and (2) an embedded portion or chromonematic element. During early prophase this chromone-

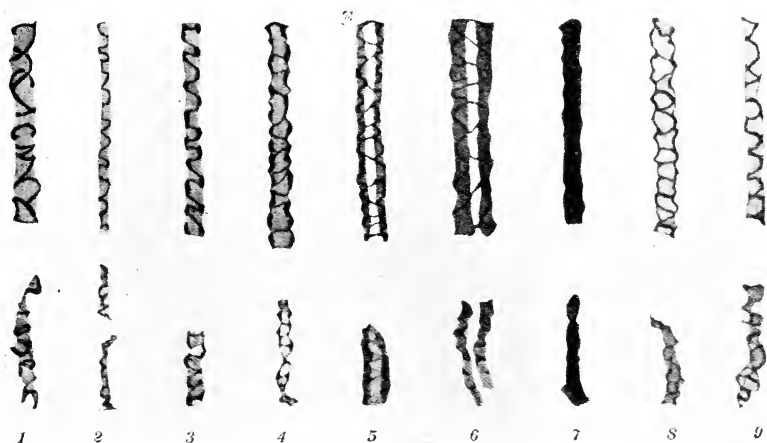

FIG. 70.—Structural changes undergone by the chromosomes in somatic mitosis in *Paris quadrifolia*. (After Martens, from Sharp, *Introduction to Cytology*.)

matic portion has the structure of transverse or oblique curved strands lying peripherally in the matrix, and many of these are joined to form a zig-zag thread, but they do not constitute a continuous spiral throughout the length of the chromosome. During the later stages of prophase they become continuous, and after division of the chromosomes this chromonematic element, which at all times is accompanied by its achromatic matrix, still retains its zigzag form until late in interphase, when it becomes broken up into irregular strands. According to the view put forward by this worker, the chromonema is a constant structural element of the chromosome.

Bolles Lee, working with *Paris quadrifolia*, claimed that the structure of plant and animal chromosomes is essentially the same. He found that in the homotypic division of meiosis there was an achromatic axis which at certain stages of division showed a periaxial spiral differentiation, connected by means of a spiral flange (these flanges appeared as lateral processes) surrounded by an achromatic membranous sheath. According to Lee, the essential difference between plant and animal chromosomes lies in the fact that the former occasionally show alveolation, and the axes of the latter are always more solid.

Another general view of chromosome structure is that the achromatic matrix encloses a number of discrete chromatic units, the so-called *chromomeres*. At prophase these chromomeres unite in more or less regular rows in the matrix, which is also a constant element of chromosome structure. Sands has investigated the chromosomes of *Tradescantia virginica* from this standpoint. His description is limited to the structure displayed by the chromosomes of the pollen-mother cells at diakinesis, their arrangement on the equatorial plate, and their structure at anaphase and early telophase in both pollen-mother cells and somatic cells. The acetocarmine method was employed. Sands considered that his results support the view that the achromatic matrix forms a foundation for a number of chromomeres. These chromomeres are arranged irregularly within a linear cylinder. The surface of this cylinder may be either smooth or irregular, according as the chromomeres do or do not project beyond the periphery.

More recently Sharp has reinvestigated this problem in a number of different plants. The species used were *Trillium grandiflorum*, *Allium cepa*, *Podophyllum peltatum*, *Vicia faba* and *Tradescantia virginica*. Benda's fluid was mainly used for fixation. The observations were confined to the large somatic chromosomes of these plants. In all cases it was found that the chromosomes were composed of two principal morphological units, which exhibited considerable differences in their affinity for stains during late telophase, interphase and early prophase of mitosis. These staining differences, however, are by no means so marked at late prophase, metaphase, anaphase and early telophase.

Throughout the mitotic cycle the more chromatic constituent of the chromosomes persists in the form of two chromonemata. The less chromatic constituent forms a matrix in which the chromonemata lie for the major portion of the cycle. It was found impossible to obtain any information as to whether it remains distinct from the matrix material of the other chromosomes and the karyolymph at interphase or whether it merely loses its identity between nuclear divisions.

At anaphase the chromosome is made up of an achromatic matrix and a more chromatic constituent; the latter has the structure of a zig-zag thread or chromonema. This thread frequently appears double, *i.e.*, there are two chromonemata present which may either remain close together at the upper region of the chromosome or separate rather widely at the lower portion. With the close of anaphase, the chromosomes shorten, and at the inception of telophase, the chromaticity of the chromosome matrix decreases considerably, leaving the chromonemata more clearly visible. At telophase the chromonemata are more contorted than at anaphase, owing to the shortening of the chromosome as a whole. Mutual connections now make their appearance by means of anastomoses with neighbouring chromosomes to form the reticulum of the daughter nuclei.

The alterations observable in the chromosomes at telophase are continued into interphase, when the individual chromonemata can still be observed. Finally, the anastomoses of the main portion of the chromonemata become more and more alike, so that the latter are no longer discernible in the meshwork of the resting nucleus. In the meantime the matrix material of several chromosomes becomes entirely achromatic and apparently continuous. At early prophase the reticulum is resolved into separate tracts, which represent the chromosomes in which the chromonemata become more and more visible with the disappearance of the anastomoses. The matrix of each chromosome also becomes more visible than the surrounding karyolymph. The chromonemata now become more clearly distinct and regular, giving the aspect characteristic of the spiral stage. At the middle of prophase the chromonemata straighten out, thicken and diverge a little as they

take up positions on the borders of the flattening matrix. When prophase has been concluded the structure of the chromonemata is difficult to see, but they appear to be a little contorted. At metaphase each daughter chromosome can be seen to be composed of a matrix containing two chromonemata, so that the entire metaphase chromosome is double in respect to the matrix and quadruple with respect to the more chromatic constituent. For further details of this work the original should be consulted.

As Sharp has very rightly pointed out : "the problem at present confronting students of chromosome structure is to place a proper evaluation upon these appearances presented by chromosomes under the microscope. It seems clear that the chromatic substance which has been called karyotin, and which is arranged in a slender thread, with or without achromatic elements in the prophase, is a constant nuclear constituent. It has been variously described as having the form of granules, irregular short strands, a continuous spiral chromonema, a spongy framework and a cortical sheath. All of these aspects have been observed in sectioned material fixed by the older methods, as well as in whole chromosomes by the recently readopted acetocarmine process. Opinions differ widely with respect to which are natural aspects and which are artifacts. Probabilities seem to favour the naturalness of a regular type of structure, such as is exemplified by chromonemata, as against the irregularity characterising a spongy framework, arising through alveolation or a matrix with scattered granules."

Work on chromosomes from living cells has not progressed sufficiently far as yet to determine which of the conflicting views at present in vogue is correct. It is probably correct to say that in all fixed material, by whatever method, a certain number of artifacts are bound to make their appearance, and it is the presence of these artifacts that makes this particular problem of cytology so difficult for investigation.

THE NUCLEOLUS

Practically all nuclei contain one or more bodies which are termed nucleoli or are occasionally spoken of as plasmosomes. As a general rule they are not present in the nuclei of male gametes.

In character the nucleolus is somewhat irregular in shape and may possess one or more vacuoles, in which small granules are occasionally found. The nucleolus shows an affinity for acid dyes, and according to Meyer, Zacharias and others, it is mainly composed of proteinaceous material. In *Allium* root, according to de Litardière, the substratum of the nucleolus is made up of some achromatic material which is impregnated with a less resistant chromatic substance or substances.

Till within recent years, there has always been considerable divergence of opinion with regard to the function of the nucleolus, but the trend of recent work has shown that it plays an important part at mitosis and supplies chromatin to the developing spireme.

In his investigations on ferns de Litardière observed that there was an inverse ratio between the chromaticity of the chromosomes and the volume of the nucleolar mass. He therefore suggested that chromatic material passed out of the chromosomes at telophase and formed the nucleolus, which in turn at telophase passed chromatic material to the chromosomes once more. In a similar manner, Martens discovered that in *Paris quadrifolia* the achromatic matrix of the chromosomes showed a very decided chromaticity at late prophase, metaphase and anaphase, and that this chromaticity was lost at telophase. He thought it probable that this was due to a transfer of chromatic material from the nucleolus to the matrix of the chromosome during these various stages of mitosis.

A more elaborate study of the matter was conducted by van Camp on the root meristem of *Clivia*. Here apparently the reticulum of the nucleus is basophile, whereas the nucleolus is acidophile and has an avidity for iron, and the two are in direct contact. At the inception of prophase the spireme becomes more iron-avid, with simultaneous decrease in the size of the nucleolus. Finally the nucleolus breaks up into small fragments and becomes less iron-avid. With the completion of prophase the nucleolar material has passed entirely to the developing chromosomes. Van Camp claimed that the chromosomes are not simply impregnated by material from the nucleolus, but that the two form a special

complex to which he has given the name "kinochromatin." At telophase, dissociation of the two substances takes place once more, and the iron-avid and acidophile materials make their appearance at certain points along the chromosomes as small globules, and these eventually fuse to form fresh nucleoli. Cleland has also brought forward evidence of a similar nature. In *Oenothera franciscana sulphurea* he found that the microsporocytes showed nucleoli as rather pale bodies after chromatic material had left them.

Latter has shown that the nucleolus of *Lathyrus odoratus* adds chromatic material to the developing chromosomes during pollen formation. The nucleolus here stains deeply, and is more or less spherical in shape. In the peripheral region of the nucleolus there is apparently a greater staining power than in the central region giving the appearance of a large central vacuole and a crystal body, which varied in shape, was found within the vacuole. A similar body has been described in *Oenothera* by Cleland. Occasionally two or even three such bodies were found to be present, but their nature was not ascertained. The suggestion is put forward that they are possibly composed of proteinaceous material.

In normal nucleoli, after they have assumed an elliptical shape at synizesis and come into contact with the nuclear membrane, the mass of delicate threadwork generally appears to move away from the nucleolus and takes up its position on the side opposite to the nuclear cavity. The separation, however, of the knot of thread is never complete, and the nucleolus, which lies flattened against the nuclear membrane, is connected to the compact mass of thread by means of a few delicate strands. The very constant connection of the thread with the nucleolus during the distribution of deep-staining material along it suggests that a transference of chromatin from the nucleolus takes place.

As the synizetic knot passes away from the nucleolus across the nuclear cavity, only a single crystalline structure can be seen and one or more loops of the thread remain definitely in contact with the nucleolus, the apex of at least one loop being directed towards this structure. Prolonged examination, however,

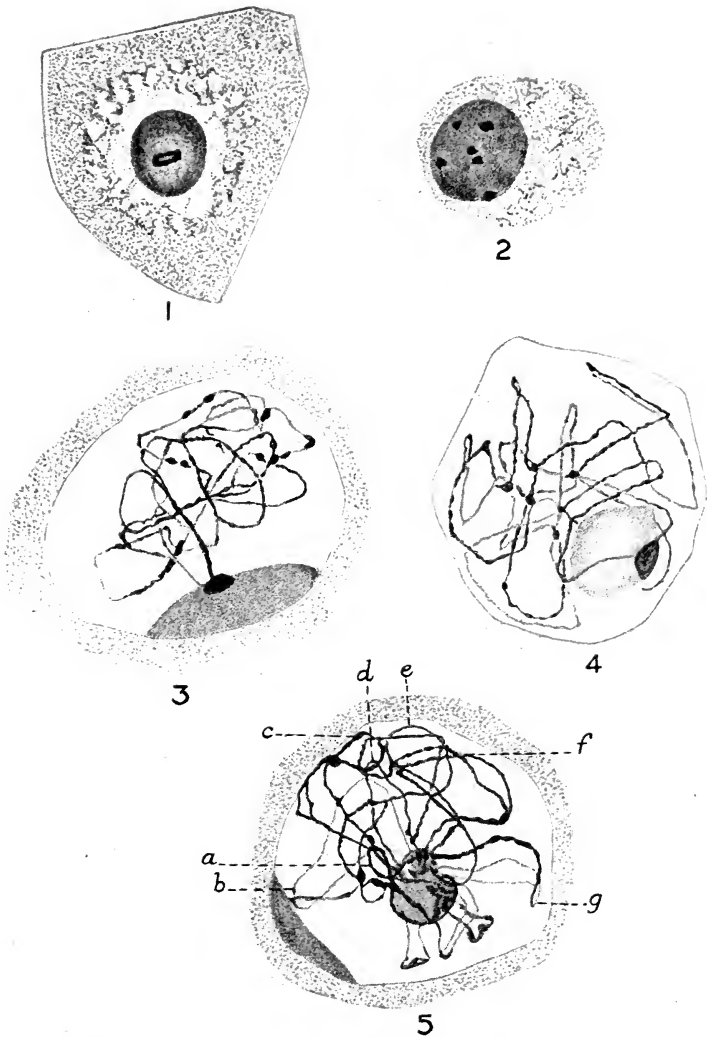

FIG. 71.—Nucleolar behaviour in *Lathyrus odoratus*. (1) Resting pollen mother cell with a crystal body in the central vacuolar region of nucleolus. (2) Faintly stained nucleolus showing minute dark-staining granules, which are probably fragments of the crystal body. (3) Spireme loosened from synizetic knot. The spireme is a continuous thread attached to nucleolar body. (4) Same as (3). The nucleolus is lying against the upper membrane of the nucleus, being in a focus higher than the other nuclear contents. (5) Seven persistent loops of the spireme can be distinguished from a mass of smaller loops and are lettered *a-g*. A split is present in the thread of some of the main loops, but this is not generally observed in nuclei at this stage. The loops appear to radiate from a central nucleolus. (After Latter, *Anns. Bot.*)

showed that one loop of the thread was definitely in contact with this inclusion. Other nuclei, which present a similar stage of development, show a loop of the thread attached to a darkly staining oval body at the periphery of the nucleolus and no crystal occlusions are simultaneously present. With the loosening of the thread from synizesis, the peripheral darkly staining body becomes considerably larger and more conspicuous and the connecting threads still in contact with the nucleolus are very constantly associated with it. Except for the presence of this deeply staining-body (nucleolar body) the nucleolus is apparently homogeneous at this stage. It would appear that this nucleolar body is derived from the crystal occlusion of the resting nucleolus. With the inception of the second contraction, the nucleolus frequently shows budding and partial fragmentation, and the extruded portions remain in the nuclear cavity as additional nucleoli and the remaining portion of the nucleolus at the periphery becomes very vacuolated in appearance. During the passage of the nucleolus to the periphery of the contracted reticulum, several small nucleolar can be seen. Their appearance suggests that the large crystal body of the nucleus has undergone fragmentation.

The fact that the time of association between the reticulum and the nucleolar body coincides with the time of the chromatic thread formation, suggests that the nucleolar body is of importance in the passage of chromatic material to the linin thread. In the open spireme stage, the nucleolar body is considerably larger than in the early stages of synizesis. This proves that it cannot be the actual substance of the original nucleolar body alone which is passed on to the thread, but suggests rather that the function of the body is that of an elaborating organ, and that it transfers elaborated material to the thread with which it is in contact.

Similarly, Gates and Latter discovered very much the same state of affairs in *Lathraea*. Unlike *Lathyrus* and most other forms, the nucleolus never became crescent-shaped against the nuclear membrane, but remained approximately spherical throughout the prophase stages. Again a constant association was found of the post-synizetic reticulum with one or more nucleolar bodies as in *Lathyrus*, and crystal bodies were also found to be present.

Zirkle claims to have separated nucleolar material from the chromatin of the reticulum and also from mitochondria in *Zea mays*. In the resting nucleus all the chromatin is localised in the reticulum and the nucleolus contains none. It was found impossible to detect whether any strands connect the nucleolus with the reticulum in the living resting nucleus. At prophase of mitosis, however, a very distinct connection can be seen to be established between the nucleolus and spireme and this connection is attached to the narrow end of the rather pear-shaped nucleolus. Often a double connection can be detected owing to the splitting of the nucleolus and nucleolar material can be seen flowing into the spireme across the connecting bridge.

It was found that when the root tips were fixed in zinc or nickel bichromate, results somewhat contradictory to this view were obtained. But when the material was fixed in nickel-chrome-acetate (pH 5.0—5.2) the entrance of nucleolar material into the developing spireme could be very readily seen, as this fixative dissolves all the chromatin and mitochondria. At a later stage the nucleolus can be seen connected at two places with the spireme; it then becomes drawn out and finally constricted into two parts which pass to opposite poles of the spindle. The nucleolar material thus enters the daughter nuclei in two ways: (1) in the chromosomes, and (2) as a distinct body. The latter reaches the poles of the spindle first, and the nucleolar globules then proceed to fragment, the majority of the fragments passing into the cytoplasm, while the chromosomes are still on the equatorial plate. At telophase the nucleolar material which has been contained in the chromosomes collects into droplets, which flow together and reform the nucleolus of the resting nucleus once more. The nucleolar material is thus continuous, and is derived from pre-existing nucleolar material; a certain amount, however, is lost at each division by the process of fragmentation and ultimate disappearance described above. Zirkle considered that the nucleolus has two possible functions: (1) that it transmits the influence of the genes to the organism, and (2) by means of its electro-positive charge it serves as a framework for the distribution of chromatin to the daughter cells.

More recently Sheffield has confirmed the various observations recorded above in different species of *Oenothera*, and finds like these different authors that there is transference of chromatin from the nucleolus to the developing spireme.

It will be seen, that contrary to the view of the older workers, the nucleolus apparently plays an important part in the activities of the nucleus, and is not a reservoir of waste material as was thought at one time. But although the examples cited above do show that a significant relationship exists between the nucleolar material and the cyclic alterations of the chromosomes, the exact nature of this relationship yet remains to be determined.

NUCLEAR DIVISION

It is not proposed to deal here with the ordinary process of mitosis in the nuclei of the higher plants. This aspect of nuclear division is dealt with at length in the ordinary text-books on the subject, and only certain peculiar methods of nuclear division found in some of the lower fungi, algæ and the bacteria will be discussed.

Plasmodiophorales. The members of this order of fungi form a natural but very isolated group, with no evident affinities to the rest of the fungi. They exhibit two types of nuclear division in the course of their life-history, one during the growth of the amœba, which is continued up to the time of spore formation, and the second represented by two successive divisions directly associated with reproduction. The first method of nuclear division is often termed "protomitosis" or "cruciform" division, while the method of division associated with spore formation is typically mitotic and apparently constitutes a meiotic phase. Separating these two different types of division is the so-called "akaryote" stage, during which stainable chromatin is extruded into the cytoplasm.

Cook has investigated *Ligniera junci* in regard to its nuclear divisions. This member of the Plasmodiophorales is a root parasite of *Callitriche stagnalis*. The resting nucleus is about 2.5μ in diameter, more or less spherical in shape and surrounded by a deeply staining nuclear membrane. The chromatin forms a

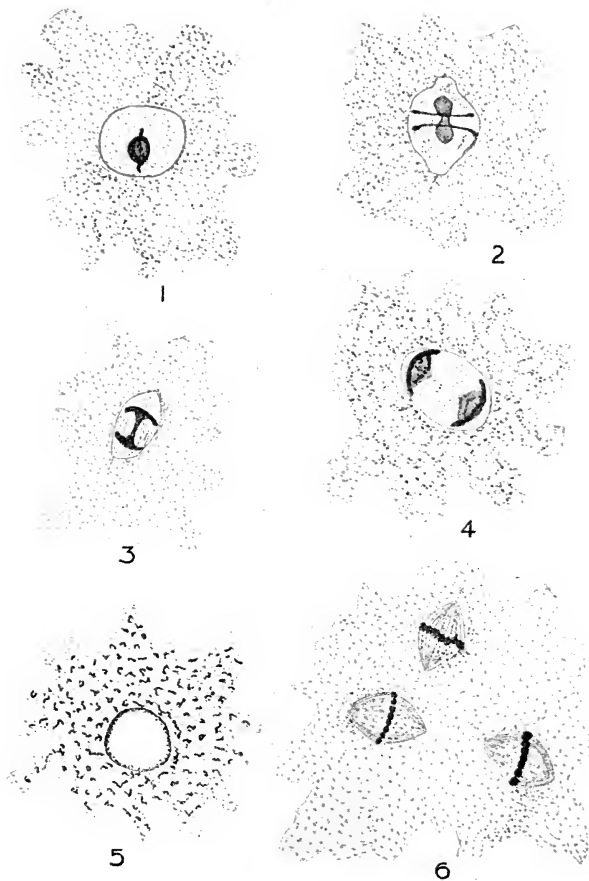

FIG. 72.—(1) Protomitosis, a very early stage in which the plate is beginning as a slight excrescence of the edge of the nucleolus. (2) The split of the chromatin plate into two thin plates, which show slight enlargements at their ends. The spindle is visible and the nuclear membrane has become characteristically shaped. (3) "Double anchor stage." The plates have now become drawn apart and the nucleolus has nearly split. The spindle has become more diffuse and the plates are slightly curved. (4) Plate has become divided, spindle fibres are less visible and the nucleolus has become drawn out and dumb-bell shaped. (5) Akaryote stage. Chromatin extruded into cytoplasm and nucleolus has vanished. (6) Spore formation. Heterotypic metaphase. The nuclei in the first division of spore formation, showing clearly marked spindle and chromatin differentiated into chromosomes. (After Cook, *Ann. Bot.*)

thin peripheral area of deeply staining material lying within the nuclear membrane. It is granular in nature and not visibly aggregated into a chromatin reticulum. A well-marked spherical nucleolus is also present. At the initial stage of protomitosis there is an aggregation of peripheral chromatin to form a ring (Fig. 72, 1) round the periphery of the nucleus in close association with the nuclear membrane. Simultaneously intranuclear spindle fibres make their appearance, lying across the nuclear cavity at right angles to the chromatin ring. The spindle is equal on both sides of the chromatin plate and the chromatin appears as a line lying across the nuclear cavity. The ring of chromatin now splits across, forming two rings, which are apparently similar to one another in size and shape (Fig. 72, 2), and the central nucleolus (karyosome) elongates at the same time and lies across the chromatin plate. As soon as the split becomes more evident in the chromatin plate, the nucleolus becomes still more elongated. The nuclear membrane at this time becomes less spherical and begins to elongate in the same direction as the nucleolus. Further elongation of the nucleolus leads to its spherical ends being joined by a thin strip. The chromatin plates precede the nucleoli to the poles of the spindle and a "double anchor" or dumb-bell effect is obtained. Finally the nucleolus separates into two and the chromatin plates become more or less completely curved round the two parts. There is no clear evidence at this stage of chromosomes, or for the matter of that at any stage of protomitosis.

The reproductive phase in these plants is separated by the so-called akaryote stage. This is brought about by the gradual reduction in the size of the nucleolus, which eventually disappears. The chromatin within the nuclear membrane shows a gradual decrease in amount, and small granules of chromatin make their appearance in the cytoplasm. Finally all the chromatin passes from the nucleus through the nuclear membrane into the cytoplasm.

At the conclusion of the akaryote stage, the nucleus is reorganised and a typically mitotic division takes place, in which apparently there is a reduction in the number of chromosomes. This mitotic division occurs immediately before spore formation. The

prophase is difficult to see, but the metaphase is very distinct and shows the chromosomes very clearly on the equator of the spindle. At the completion of the first division, which was held by Maire and Tison to be a reducing division, there is a second division, which is presumably of the same nature as the homotypic division of the higher plants.

This very curious process of protomitosis or cruciform division has always been held to be the correct interpretation of the nuclear divisions of these plants, and the various stages described by Cook have been found by all the earlier workers. His description of the process merely differs from the older investigators by the use of more up-to-date methods of technique. A very different interpretation of the nuclear phenomena exhibited by the Plasmodiophorales has, however, recently been put forward by Horne. A number of different genera were investigated, *e.g.*, *Spongospora*, *Sorosphaera* and *Plasmodiophora*. Horne claimed that the somatic divisions are typically mitotic in character, and that all the existing accounts are entirely unsatisfactory. According to his description the nucleus has a definite membrane, and viewed from a median plane presents a configuration very similar to that of a wheel with a centrally-disposed nucleolus and chromatin threads radiating from it. The same general type of structure was found in the resting nuclei of all three genera. At the onset of division the reticulum breaks down into a spireme. At metaphase the chromosomes become united end-to-end to form a continuous band surrounding the nucleolus, and this band then divides to form two daughter bands, which finally break down to form the daughter chromosomes at anaphase and telophase. The nucleolus is a prominent structure of the nucleus, and persists throughout division. It is these continuous bands of chromosomes which, according to Horne, have been misinterpreted by previous workers into the well-known cruciform structure exhibited by these nuclei.

After an unrestricted period of mitotic activity, the nuclei cease to divide and become achromatic. Presumably this achromatic appearance of the nuclei corresponds to the akaryote stage of other investigators. Horne assumed that a fusion of coenocytic growth forms takes place at some stage, and that this union in the

life-history is followed by fusion in pairs of nuclei of opposite sex during this stage. No evidence, however, is brought forward in support of this statement.

At the conclusion of the transitional period the reconstructed nuclei show a well-developed aster and centrosome, but the nucleolus is inconspicuous. These nuclei are considered to be diploid in nature. Meiosis now occurs; the first division is held to be heterotypic, and the chromosome number is reduced according to the telosynaptic scheme of Farmer. A homotypic follows the heterotypic division, and occasionally there is a third division which immediately precedes spore formation.

Cyanophyceæ. The cell structure of the Cyanophyceæ, or blue-green algæ, has always been a subject of much dispute. It has been known for a considerable time that there is in the cells of these plants a central region which is relatively colourless in comparison with the rest of the cell contents. It is the nature of this central body which has led to such acute differences of opinion. The more general view is to regard it as corresponding to a nucleus, but its nuclear nature has also been extensively denied. According to Kohl, Olive and Phillips, the central body of the Cyanophycean cell is a nucleus which divides mitotically. But these workers differed materially among themselves as to the arrangement of the chromatin and the actual details of division. Fischer, on the other hand, denied the presence of a nucleus in these cells, while Gardner held that the small refractive granules which he found in the cells of these plants possessed a definite outline characteristic for each species and regarded this as the true nucleus, but considered that it did not divide mitotically.

Acton has investigated the nature of the central body very fully for the *Chroöcocceæ*. She found in this family that there was no highly specialised nucleus such as is present in the higher plants. There was, however, a gradual transition in the cells from an almost undifferentiated condition in the lower types to a somewhat specialised one in the higher, of which *Chroöcoccus macrococcus* represented the highest type and *Merismopedia elegans* an intermediate stage. The protoplasts consisted of a ground substance transversed by a reticulum of thin threads with thickenings

at the nodal points. These were termed "plasmatic microsomes," and served as centres for the accumulation of reserve material elaborated by the pigmented parts of the protoplast. In the greater number of species that were investigated there was no clear differentiation into central and peripheral region, but the plasmatic microsomes in the centre of the cell accumulated meta-chromatin, while those at the periphery accumulated cyanophycin. This is best exemplified in *Chroococcus turgidus*. In *Gleocapsa* many of the cells showed a deeply staining network in the central region, somewhat simulating the spireme stage of normal mitosis. *Merismopedia elegans* showed the presence of a definite central body at the time of division. This, however, was not of the same nature as the nucleus of the higher plants, but was apparently an accumulation of chromatin or allied material at the nodal points of a small and definite area in the centre of the cell. *Chroococcus macrococcus* showed the highest type of central body. This central body was definitely nuclear in nature, and the cell contents could therefore be differentiated into nucleus and cytoplasm. Only the peripheral portions of the central body stained with the usual nuclear stains and showed a fine reticulum of chromatin at the nodal points. There was a sap-vacuole in the interior of this nucleus. According to Acton, the evolution of the so-called nucleus in this group has taken place along the following lines: excess of food material elaborated by the pigment of the protoplast was first stored by the plasmatic microsomes as the carbohydrate, cyanophycin. As, however, more and more material was elaborated, the reserve in the centre of the cell became more complex in nature and the protein metachromatin granules were formed. In the course of time this accumulation of nucleo-protein was restricted to a particular area in the cell, and at first this restriction only occurred at division (*Merismopedia*). In this way a portion of the cell came to be physiologically differentiated on account of its function in connection with division. This area is the nucleus. At a still later stage this incipient nucleus became stabilised and was always present. *C. macrococcus* exhibits the most primitive stage in the evolution of the Cyanophycean nucleus. The central body here divides and there is no evidence of mitosis. It

seems to remain permanently in the stage resembling the resting nucleus of the higher plants. Repeated division of the cell appears to diminish the comparative size of the central body, for in older cells it is always somewhat small compared with younger ones.

Haupt has also investigated the "nucleus" of several genera of the Cyanophyceæ, but obtained his best results with *Anabaena circinalis*. The ground substance here was found to be distinctly granular in nature, and highly vacuolated. The cyanophycin granules were confined to the peripheral region of the cell. He was quite unable to find any evidence of a differentiated central body or nucleus described by other workers. The undifferentiated protoplasm was found to be evenly distributed throughout the entire cell, the peripheral region differing from the central region in the presence of pigment. Haupt, however, was able to find a stainable granular body in the central part of the cell, which forms string-like masses somewhat resembling chromosomes. It is, however, homogeneous in nature and shows no signs of differentiation into chromatic and achromatic portions, and has no resemblance to the nuclear reticulum of the higher plants. Cell division takes place by means of a centripetally-growing cell wall, and at the same time the central body becomes constricted into approximately two equal halves, a division which is strictly amitotic in nature. This central substance shows many resemblances to the chromatin of normal nuclei, but Haupt refuses to regard it as being nuclear in nature.

Bacteria. The problem of whether or not the bacteria are possessed of a nucleus has always been a difficult one to settle. The minute size of these organisms makes observation, and therefore interpretation, a matter of difficulty. The presence of chromatin granules scattered in the cells of these forms has been known for a very considerable time, but workers have disagreed as to the exact significance that should be attached to them and whether they may be regarded as homologous in nature to the nuclei of higher organisms. The view has also been seriously put forward that the whole bacterial cell is in reality a nucleus.

Some interesting observations have recently been made on this problem by Stoughton, who worked with *Bacterium malva-*

cearum, which is the cause of the "angular spot" disease of the cotton plant. He first observed the presence of deeply-staining structures within the body, especially in cultures more than four days old.

The bacterium was grown on potato agar or a synthetic medium of K_2HPO_4 (0.1 per cent.), KNO_3 (0.2 per cent.), $MgSO_4$ (0.1 per cent.), $NaCl$ (0.1 per cent.), glucose (1.0 per cent.) and agar (1.5 per cent.). The staining technique employed was as follows: chemically-cleaned slides were flamed and a drop of Ziehl carbol-fuchsin (diluted with an equal volume of water) was placed at one end of the slide and a thin film of stain made by drawing the edge of a strip of typewriting paper over the drop and along the slide. For success, the film should dry rapidly and evenly and be barely perceptibly visible when the slide is held up to the light. A small drop of sterile water was now placed on the middle of a flamed thin cover-slip. This was touched with a platinum wire carrying the organisms from the culture, and the cover-slip was then inverted and dropped on the stained slide. The mount was sealed with vaseline or gold size. The bacteria take up the stain slowly if the film has been correctly prepared.

In general appearance, in cultures twenty-four hours old, the bacteria show a preponderance of slender rods which stain more or less evenly and deeply and vary in size from 1.5 to 4.0 μ by 0.5 to 0.9 μ , and are cylindrical with rounded ends. If the stain be not too intense and the slide be examined immediately after preparation and before staining is complete, a number of the cells can be seen to contain a deeply-staining spherical granule (rarely two or more such granules may occasionally be observed). These spherical bodies, as a general rule, are situated towards one end of the cell, and are conspicuous by reason of their greater affinity for the stain. This structure is soon lost to view because the rest of the cell takes up the stain. After the lapse of three to four days, the cells in culture lose their power of staining evenly over their whole surface, and another structure now becomes visible. This body is centrally placed, and shows a different appearance in different cells. Concurrently with the appearance of the central body, the granules previously referred to

take up stain with much avidity. The central body is, however, most readily observed in cells ten days old, and bears some relation to the condition of the cell with regard to the process of division to be described below. It is homogeneous in nature, and more or less spherical in form, in cells which have recently been produced by division, but in some cells, apparently at the same stage, the body presents the appearance of a four-lobed or "tetrad-structure." Owing to the minute size of this body, the existence of such a "tetrad" is very largely conjectural.

While division of the cells is in progress, the central body

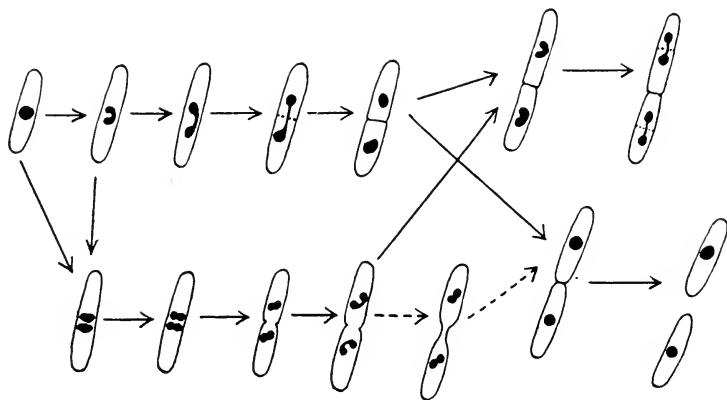

FIG. 73.—Diagrammatic representation of hypothetical alternative division-cycles in the vegetative cell of *Bacterium malvacearum*. (After Stoughton, *Proc. Roy. Soc. (Lond.)*.)

becomes dumb-bell shaped and is comprised of two rounded bodies ; one in each of the daughter cells with a connecting strand between. In other cells, each end of the dumb-bell shaped figure appears to be more or less bilobed or double. In some of the cells this structure appears to be much elongated, and shows only small signs of a dumb-bell shape. This latter phenomenon is usually associated with elongation of the cell as a whole, such as is commonly the case when transverse fission takes place. On the other hand, in some cells, the central structure appears to have completely divided into two portions before much elongation of

the containing cells has occurred. These last two appearances are apparently associated with two different types of fission of the bacterial cell. In the first case, the central structure elongates with the simultaneous elongation of the cell, and later seems to divide by the simple process of pinching through, much as though it had been stretched and had given way in the middle, whereas in the second case, which seems to be derived from the previously described dumb-bell by separation of the two halves, the division of the cells appears to be accomplished by the laying down of a definite transverse wall between the two halves of the central body.

It would seem a reasonable hypothesis to consider that the various appearances described above represent definite phases in a division cycle (which possibly entails two alternative modes of division of the originally single central body), and that this cycle or cycles is in some way connected with the normal fission process of the bacterial cell (Fig. 73).

Observations were also made on living cells. These also showed the central body as an ill-defined refractive structure, which in the course of division elongated to a dumb-bell form and finally divided into two halves. Each half passed into one of the daughter cells in the same way as in stained preparations.

The behaviour of this central body certainly conforms in a remarkable manner to that of a nucleus, and the process of division is apparently typically amitotic in nature.

ACHROMATIC FIGURE

Recent investigations on living tissues have introduced a number of modifications into our conception of the origin of the achromatic figure. In plants, unlike animals, it is only in the lower groups that a centrosome is present. This body is absent, for example, in the Spermophyta. Thus, the achromatic figure in plants is of two types, one with asters and centrosome (amphiastral type), and the second without these structures (anastral type).

In the lower plants, such as the fungi and algæ, the achromatic figure is characteristically intranuclear. For a very complete

description of these figures see Bagchee for the ascomycete, *Pustularia bolarioides* and Carter for *Padina Pavonia*.

In the ascomycetes, three nuclear divisions occur in the ascus, leading to the formation of eight daughter nuclei, which form the nuclei of the ascospores. The centrosome in these forms is often discoid in shape and lies against the nuclear membrane. With the onset of mitosis, the aster develops in the cytoplasm above the centrosome, and the latter now divides to form two daughter centrosomes. As the daughter centrosomes move apart, the fibres of the intranuclear spindle can be seen projecting into the nucleus. When the centrosomes reach the opposite sides of the nucleus, the two groups of fibres become arranged in the form of a sharp-poled spindle stretching across the nucleus with the chromosomes arranged at the equator. As a general rule, the nuclear membrane remains intact until the chromosomes approach the poles of the spindle at anaphase, when it may disappear and the nucleolus escapes into the cytoplasm. There is thus no doubt that in these forms the achromatic figure is of nuclear origin.

The origin of the achromatic figure in the higher plants has led to a good deal of controversy. On the older view special substances were postulated in the cell to account for the origin of the figure. Nothmager advanced the view that exosmosis of the karyolymph through the nuclear membrane into the cytoplasm caused precipitation of the fine fibrils which compose the figure. This view has been upheld by Tischler, who also suggested that intranuclear figures are formed in the same way, except that it occurs here through the inward diffusion of cytoplasmic fluid.

The view that the achromatic figure is entirely nuclear in origin has come to the fore within recent years from the investigations of Devisé and Robyns. Devisé considered that the figure was solely nuclear in origin in the sporocyte of *Larix*. It would seem that the karyolymph becomes altered in some way by the cytoplasmic fluid after the shrinkage and disappearance of the nuclear membrane.

Robyns has conducted a more elaborate investigation of the problem of the origin of the achromatic figure. The plants principally used were *Vicia faba* and *Hyacinthus orientalis*. For

the complete details of this work the original memoirs should be consulted. It was found in the root tips of both *Vicia* and *Hyacinthus* that the nuclear membrane, together with the chromosomes, first contracted into a "chromosomic pouch" away from the two poles of the original nuclear area after a period of enlargement and left behind it two polar caps of hyaline nuclear sap, which allowed the nuclear membrane to retreat by filtering through it. These caps, which eventually become the spindle cones, were thus topographically nuclear. They were composed of karyolymph, which lay between the shrunken nuclear membrane and the cytoplasm. Although there was addition to the karyolymph of cytoplasmic fluid during the time of nuclear enlargement, the cytoplasm contributed no formed element to the developing achromatic figure. Further, according to Robyns, the spindle is optically homogeneous in the natural condition, and the visible fibres and lamellæ which can be observed in fixed material are the consequence of improper fixation (Fig. 74).

CYTOKINESIS

The differentiation of masses of protoplasm into cells is accomplished in a number of different ways. In the lower plants the method of separation is as a general rule by means of cleavage furrows or by the accumulation of vacuolar material in special regions and by the formation of cell-plates in the equatorial region of the achromatic figures at the end of mitosis. The term "cytokinesis" is given to the differentiation of extra-nuclear protoplasm.

In the lower Thallophytes, *e.g.*, fungi and algæ, the presence of cleavage furrows is a very constant feature of cytokinesis and the process takes place in much the same manner as in animal cells. *Edogonium*, however, forms an exception, and a typical cell plate is laid down across the equator of the spindle. In sporocytes, on the other hand, the presence of a cell-plate was always considered to be a characteristic feature. Recently, however, a good deal of attention has been focussed on this particular aspect of the problem and the method of wall formation has been found to vary greatly in different groups.

The investigations of C. H. Farr and W. K. Farr have shown that furrows which are developed from the periphery inwards are mainly responsible for cytokinesis in angiosperm microsporocytes. It was discovered that in *Nicotiana* the four pollen nuclei, at the conclusion of the homotypic division, are all connected by achromatic fibrils. The two sets of connecting fibres from the second division may persist and four new sets are added, or occasionally, the two sets formed at the second division may disappear and

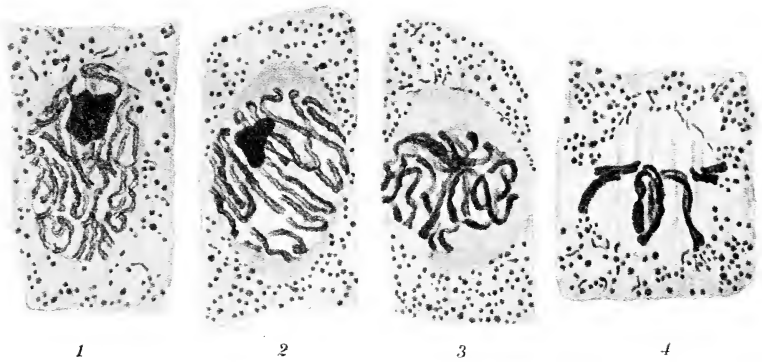

FIG. 74.—Development of achromatic figure in root tip of *Hyacinthus*. (1) Stage of greatest prophasic nuclear enlargement. (2) Polar caps present, due to shrinkage of nuclear membrane. (3) Nuclear membrane partially vanished, caps about to develop into spindle cones. (4) Spindle cones established—metaphase. Note chromosomes do not invade spindle area. (After Robyns, from Sharp, *Introduction to Cytology*.)

six new sets are formed anew. Although these fibres may show thickenings here and there on their surface, they take no part in the formation of the separating walls. Constriction furrows now make their appearance at the periphery and proceed to grow inward until finally they meet in the centre and the protoplast is thus simultaneously divided into four spores. The formation of walls in *Nelumbo lutea* has also been investigated by Farr. It was found that at the conclusion of the homotypic division the four daughter nuclei enlarge very considerably, reaching approximately four times their former volume. Quadripartition of the cell now takes place by furrowing. This begins by the appearance of a

structure which at first sight seems like a centripetally formed cell-plate. The plate, however, does not extend across the centre of the spindle, and is connected with the plasma-membrane at the periphery. The number of fibres of the spindle now increases. The furrow at its first inception is a very slender structure. During quadripartition, furrows are apparently initiated within a given mother-cell at one and the same time and proceed in their development at approximately the same rate, so that it is the portion of the central spindles between the exact central point and the exact centre of the tetra-nucleate cell which is the last to be traversed by the furrow. Finally, the furrows meet at the centre, dividing the protoplast simultaneously into four microspores.

Gates, working with *Lathraea*, has concluded that the microspores are cut off by furrows which are thickened by a special thickening secreted from the protoplasm, first from the surface generally, and at a later stage from the sides of the advancing furrows. At the end of the process the sporocyte wall and material separating the four microspores disappear and the spores are left free.

According to Gates and Rees, in *Lactuca*, at the completion of the homotypic division, constrictions appear in the cytoplasm at four points placed at equal intervals on the periphery and within the mother-cell wall. The interval between the cytoplasm and the cell wall appears to be filled with pale-staining material. These cytoplasmic constrictions now become deeper until they meet in the centre and finally divide the cytoplasm into four separate masses. The process of constriction may take place in the absence of spindle fibres, or it may even cut across them before they have disappeared, but in no case could cell-plates be observed to be laid down on the spindles, the whole process taking place independently of any such structure.

Castetter has studied cytokinesis in the microsporocyte of a biennial variety of *Melilotus alba*. Here vacuoles play a conspicuous part in the process. At the end of the second division hyaline areas begin to develop between the four daughter nuclei. These hyaline areas are apparently due to the movement of granular material from the part toward the nuclei and is accompanied by a simultaneous extrusion of liquid into the vacuoles.

The vacuoles now fuse to form larger vacuoles, which practically separate the protoplasm into four parts or masses. Furrows are now formed at the surface and proceed to grow inwards and meet the vacuoles, and complete cleavage of the protoplast is effected. At the heterotypic division callose is secreted in large amounts by the protoplast, which is only first seen at the corners of the pollen-mother cells as synizesis is initiated. With further develop-

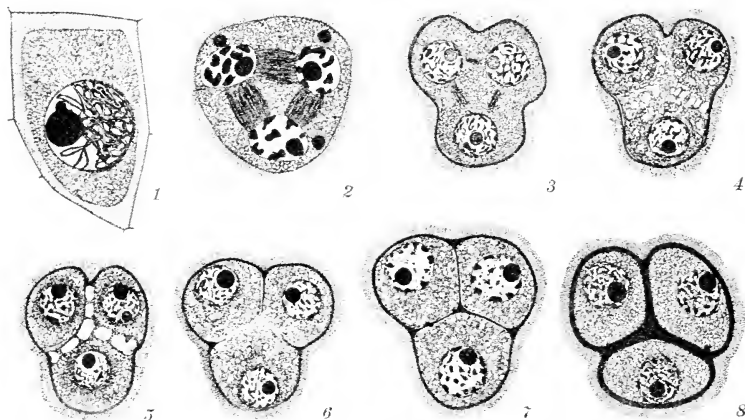

FIG. 75.—Cytokinesis in the microsporocyte of *Melilotus*. (1) Prophase of first meiotic division (callose uniformly stippled) being secreted from protoplast. (2) Telophase of homotypic division. (3) Special wall (black) and fissures appearing. (4) and (5) Vacuoles forming between nuclei. (6) Special wall extending inwards. (7) Special wall extensions have met at centre. (8) Thickened special wall complete. (After Casterter, from Sharp, *Introduction to Cytology*.)

ment of the nucleus the protoplast becomes entirely surrounded by this homogeneous substance, until in the pachynema stage it becomes quite massive. At the end of the homotypic division, and as the cleavage furrows near completion, this special callose wall advances centripetally with the furrows which soon cut into the vacuoles. Finally, partitions, which are the continuation of the incoming callose wall, are formed between the young microspores. These partitions are formed by the deposition of a callose secretion of the protoplasts on the surface of the wall (Fig. 75).

Wall formation in *Zea mays* has been investigated by Reeves. Like Casterter, he also found hyaline callose surrounding the protoplasts in the young anthers. This constitutes the mother-cell wall, and is thicker in regions where the protoplasts are in close contact. After the completion of the first meiotic division, thickenings are formed on the spindle fibres at the equator of the cell. The thickenings now fuse together and form the cell-plate, and since they follow the formation of the peripheral spindle fibres, they ultimately extend to the mother-cell wall. The cell-plate splits, and a homogeneous substance appears between its halves. This substance does not give the pectic reactions of a normal middle lamella, but is apparently of the nature of callose. The formation of cell-plates is similar after both heterotypic and homotypic divisions, and when mature, the microspores are liberated from the callose wall by its disintegration. In *Zea mays* there is no quadripartition of the mother-cell by furrowing.

MEIOSIS

It is not proposed to discuss here the rival claims made by the telo- and parasynaptic schools of thought as to the probable mechanism of chromosome reduction, but only to consider peculiar conditions of meiosis in different plant groups and their correlations.

Oenothera. The first of these that calls for consideration is the genus *Oenothera*, which has been studied in very considerable detail by Gates and his co-workers. The first publication dealing with the meiotic phase in this genus was by Gates in 1908, who showed that there was an end-to-end arrangement of the chromosomes following on synapsis. This telosynaptic interpretation has been followed by all subsequent investigators, with one or two exceptions. In fact, it would seem that *Oenothera* furnishes, *par excellence*, an example of telosynaptic reduction. Subsequent work has shown that in the *Onagra* group of *Oenotheras*, the segmentation of the spireme takes place in a characteristic manner for each species, whether it be mutant or hybrid. A certain number of free pairs of chromosomes are formed and the rest remain connected in a ring.

Following on the earlier work of Gates and Cleland, Sheffield has published an important account of cytological studies of certain of the meiotic stages of *Oenothera*. Five species were investigated: *O. novæ-scotiæ*, *O. eriensis*, *O. ammophila*, *O. rubricalyx* and *O. Agari*.

At prophase the reticulum was found to be resolved into a single apparently continuous thread which was in connection with the nucleolus. The spireme thread then gradually shortened and thickened, and all the loops were tightly drawn into a tangled deeply staining knot, from the end of which the loops sometimes projected. This knot lay close to the nucleolus. *O. novæ-scotiæ* behaved somewhat differently from this general rule during the presynizetic and synizetic stages, for at early synapsis large variously shaped chromatin masses made their appearance (Fig. 76, 4). In *O. Agari*, *O. eriensis* and the hybrid *O. rubricalyx* × *O. ammophila* these masses disappeared at an early stage, being apparently reabsorbed by the thread. In *O. novæ-scotiæ* these rounded chromatin masses were often found to be connected into a kind of chain. They disappeared, however, at pachynema. A second contraction now followed, and when the bivalents emerged, it was not usual to find them paired. They were generally arranged in rings, consisting of varying numbers of univalents, and the number present in each ring was practically constant for each species. In *O. novæ-scotiæ* and *O. eriensis* the chromosomes were arranged in a single ring of fourteen chromosomes. In *O. ammophila* there was one pair of chromosomes cut off from the rest which lay in a continuous ring. Four pairs were cut off in *O. rubricalyx* and a ring composed of six chromosomes was left. Closed rings were also present in *O. Agari*, but these were not found to be constant in their construction. These rings of chromosomes are drawn on to the spindle at metaphase.

The formation of the large rings of chromosomes in the later stages of prophase, instead of the usual pairing of bivalents, has been described for many species of *Oenothera*. When some, or all of the chromosomes are arranged in rings and at anaphase alternate chromosomes pass to opposite poles of the spindle, they are not

arranged according to chance. In *Œ. nova-scotia*, for example, in which fourteen of the chromosomes are arranged in a single ring, the total number of ways of arranging fourteen chromosomes within a single ring is 413. The total number of ways of arranging fourteen chromosomes so that alternate pairs pass to the opposite poles in such a way that no two homologous chromosomes pass to the same pole is $\frac{46 \cdot 47 \cdot 2^7}{2}$. It therefore follows that if the

arrangement be haphazard within the ring, the chances of non-disjunction taking place will be 413 : 46 · 47 · 2⁶, i.e., 429 : 16. Thus, if fourteen chromosomes be arranged within the ring according to pure chance, just over 3·5 per cent. in the heterotypic division of all homologues will pass to the opposite poles. Therefore a large amount of functionless pollen will be produced and a number of mutants thrown in each generation. Hence the arrangement within the ring cannot be according to chance. In those forms in which pairing and linkage of chromosomes is a regular occurrence, the inheritance of characters borne by the homologous pairs will take place probably according to normal Mendelian lines. The joining of the chromosomes into large rings and the ultimate segregation of those chromosomes which alternate is essentially a new form of linkage, each linkage group acting as a unit in heredity. When complete pairing occurs and linkage is observed between certain morphological characters, the factors responsible for these characters must be contained on a single chromosome. However, when the manner of segregation at anaphase is controlled by the linkage of a number of chromosomes, the factors responsible for linked morphological characters need not be situated on the same chromosome, but must be in the same group of linked chromosomes.

Abnormalities in the segregation of linked chromosomes are of frequent occurrence at anaphase and arise through two adjacent chromosomes of the spireme passing to the same daughter nucleus. This may result in a six-eight distribution. If, however, the irregularity is to the same extent compensated by two adjacent chromosomes passing to the opposite pole, the normal number of chromosomes will go to each pole, but

probably in each daughter nucleus one univalent will be missing, whilst another is duplicated. Irregularities in segregation may be the result of non-disjunction of a pair of chromosomes, the daughter nuclei thus receiving different numbers of chromosomes. Such segregation also results in the exchange of homologues between the two daughter nuclei. Usually, in non-disjunction, six chromosomes pass to one pole whilst eight pass to the other; occasionally, however, five-nine divisions are observed, and presumably they arise in a similar manner. The daughter nuclei formed as a result of such uneven segregation at meiosis continue their development in the normal way. Undoubtedly pollen grains with eight chromosomes are formed and function in fertilisation with the ultimate production of trisomic mutants. Presumably those with six chromosomes do not function, as no thirteen chromosome mutants are known. Those irregular segregations which do not result in an uneven distribution of chromosomes may still be of considerable importance genetically. Double non-disjunction may occur, homologues passing towards the same pole in each of two cases.

The significance of these results, however, cannot be properly interpreted until more is known of the process of meiosis in the megaspore mother-cell. Till the recent publication by Gates and Sheffield, it was not known whether the process of meiosis was precisely the same as that which occurs in the pollen mother-cells. The only previous publication bearing on this aspect of the problem was by Davis on *Æ. biennis*, who described strings of chromosomes in the megaspore mother-cell. It would thus appear from this work that regular groups of linked chromosomes are also formed in the megaspore mother-cell as well as in the pollen mother-cells.

Gates and Sheffield have investigated megaspore formation in *Æ. rubricalyx* in connection with linkage, which is so evident in the pollen mother-cells in this genus. In the heterotypic division of this form the reticulum becomes coarser and the nucleoli lose their vacuolate appearance, but budding of the nucleolus was not observed. An endonucleolus could, however, be seen. The reticulum contracted away from the nuclear membrane and

compacted into a tight knot. Presynizetic stages were passed through rapidly and the nucleus now contained a biconvex nucleolus, and closely adjacent to it lay a knot of chromatin material. The transformation of the reticulum into a thread was

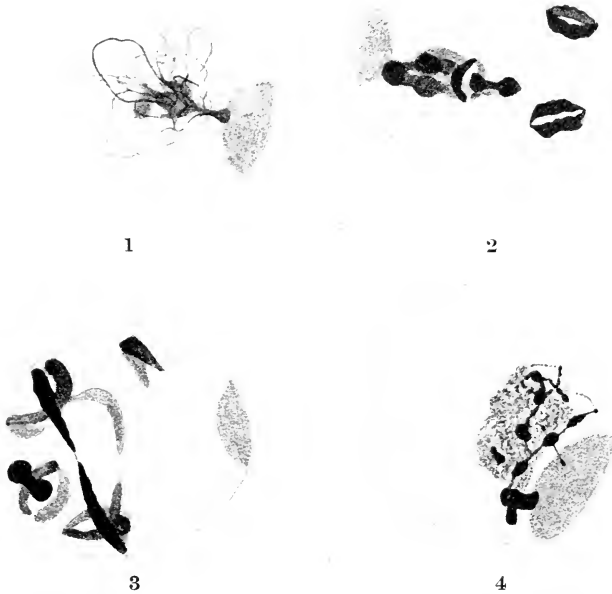

FIG. 76.—Megaspore development in *Enothera rubricalyx*. (1) Loosening of synizetic knot. The thread is connected with a dark-staining body within the larger nucleolus. (2) The segmented spireme can still be seen attached to the endonucleolus. The knot is loosening and several pairs of chromosomes have been set free. (3) Diakinesis. The spireme is now resolved into six chromosomes, arranged end-to-end and four bivalents. (4) Microsporogenesis in *E. nova-scotiae*. Synizesis. Large chromatin aggregations still persist. (1–3, After Gates and Sheffield, *Proc. Roy. Soc. (Lond.)*, 4, After Sheffield, *Anns. Bot.*)

thus completed. The fine long thread was tightly tangled, but was found to be attached to the endonucleolus (Fig. 76, 1). The staining capacity of this thread rapidly increased, while that of the nucleolus decreased. Synizesis was very prolonged and the

spireme became considerably thickened whilst it was still contracted into a knot. The synizetic knot then loosened out, and this was accompanied by thickening of the spireme. The open spireme stage was passed through with rapidity, and the second contraction was ushered in. The spireme shortened and thickened and became drawn into a dense knot which lay near the nucleolus.

When the folds of this knot gradually unloosened, it was seen that not only had the thread become divided into a number of thickened areas, each a chromosome, but that several pairs of chromosomes had become cut off from the main part of the spireme, although they might still be interlocked with it (Fig. 76, 2). The spireme was still in contact with the endonucleolus, and the nucleolus at this stage had completely lost its affinity for stains. At diakinesis the nucleolus still persisted as a pale non-staining biconvex body, lying opposed to the nuclear membrane. The spireme now broke away from the nucleolus and at the same time the endonucleolus disappeared. When the second contraction knot had completely loosened out, it was seen that the spireme had become constricted into fourteen chromosomes. Eight of these segmented off in pairs from the main part of the spireme. The chromosomes of each pair bent round so that they were approximately parallel to each other and those which were presumably free ends had usually become attached, so that each bivalent took the form of a small ring. The remaining six chromosomes, which were still joined together end-to-end, also formed themselves into a ring. It was ascertained that the ringed pairs might be interlocked with each other or with the main spireme, or they might be entirely free. The chromosomes were of a spongy nature, those forming the large ring being connected by fine threads. During diakinesis the chromosomes condensed and lost their spongy texture.

The behaviour of the nucleus at this stage, and in all the subsequent stages of the reduction division, was identical with that of the nuclei in the mother-cells on the male side. Occasional irregularities were found to occur during meiosis, such as non-disjunction, double non-disjunction, lagging and fragmentation of the chromosomes. No resting nuclei were found during

interkinesis, although a few anastomosing strands may have made their appearance. An unexpected difference was found between the megaspore and microspore formation, in that the microspore mother-cell reached a volume more than twice that of the megaspore mother-cell.

The most important of the irregularities occurring at meiosis were non-disjunction and double non-disjunction. Evidence for both these phenomena was obtained at metaphase, and daughter nuclei containing six and eight chromosomes were seen at interkinesis and also during the homotypic division. It was found impossible to estimate the frequency of such irregularities here. This is more simple when pollen mother-cell development is being followed.

The behaviour of the nucleus is thus almost identical in the formation of the megaspore and microspore, the main difference lying in size and shape.

Sheffield has studied the chromosome behaviour in a number of F_1 hybrids between self-pollinated species of *Œnothera*. The resting and earlier prophase stages of the pollen mother-cell nuclei appeared to be the same in all species of *Œnothera*, as well as mutants and hybrids, but as soon as the spireme emerged from the second contraction knot, each was found to be characterised by its own peculiar ring formation.

In the case of the hybrid *Œ. eriensis* \times *ammophila*, when the spireme emerged from the second contraction, the threads took the form of a ring composed of twelve chromosomes with one free pair. This arrangement persisted till anaphase, when the chromosomes which were adjacent in the ring drew apart and passed to the opposite poles of the spindle. Although a ring of twelve chromosomes occurred regularly in diakinesis, there was a distinct tendency for it to break at one point and to give rise to a chain before it reached metaphase. It was found difficult to determine whether the break always took place at the same point in the ring. The amount of non-disjunction was 9 per cent.

Œ. ammophila \times *eriensis*. This reciprocal hybrid was quite different, both morphologically and cytologically, from the above. Here there is no pairing of the chromosomes during meiosis and

they are all linked together in a single ring. At metaphase, neighbouring chromosomes become attached to the fibres of different poles and are slightly drawn towards the pole to which they are ultimately destined. This results in the zig-zag arrangement so typical of *Œnothera* species in which a large amount of chromosome linkage prevails. As in the reciprocal hybrid, there was a marked tendency for the ring to break into a single chain prior to metaphase. Many instances of non-disjunction and double non-disjunction were observed, approximately 10 to 11 per cent. of the former.

Œ. ammophila × *novæ-scotiæ*. The F_1 generation in this hybrid all showed *novæ-scotiæ* characters very strongly. At diakinesis the hybrid was characterised by the complete absence of pairing of the chromosomes, and once more in this case all the chromosomes were linked together in a single long closed chain. They remained in this condition till metaphase, when alternate chromosomes segregated. Non-disjunction was shown in a number of cases.

Œ. ammophila × *rubricalyx*. In this form a relatively large number of the chromosomes shows pairing during diakinesis and metaphase, and only six remained linked together in a ring. The pairs from the small rings, as in the parental types, do on occasion become interlocked with each other or with the large ring. There is often a curious infolding of the nuclear membrane during diakinesis. The amount of non-disjunction was about 8 per cent., and double non-disjunction was also frequent.

Œ. eriensis × *rubricalyx*. During diakinesis and metaphase, twelve of the fourteen chromosomes of the hybrid were linked together to form a closed chain, while the remaining two chromosomes formed a small ring-pair. The chromosomes of the large ring formed a zig-zag pattern at metaphase and adjacent ones separated at anaphase, when the homologues of the small ring-pair also separated. Again non-disjunction (10 per cent.) and double non-disjunction was frequent.

Œ. rubricalyx × *novæ-scotiæ*. In this case a ring of twelve chromosomes was formed. At anaphase segregation occurred in the usual way. The amount of non-disjunction was over 12 per cent.

It has been known for a long time that the *Oenotheras* differ from other plants on hybridisation ; the specific hybrids are very constant throughout all succeeding generations. Chromosomal linkage can be correlated with much of the genetical behaviour of these plants. The constancy of interspecific hybrids, the production of twin hybrids and the differences resulting from reciprocal crossing, can be correlated with chromosome behaviour. The occurrence of chromosome linkage, resulting as it does in linkage between the genes of a number of chromosomes, modifies normal Mendelian behaviour. It enables hybrids to breed true and behave in the same way as wild species. Indeed, there is little obvious difference between known hybrids and wild species. For the present, the origin of the rings of chromosomes still remains a controversial point and only further breeding can lead to a true understanding of the problem relevant to chromosome linkage.

Gates and Sheffield have investigated five generations of hybrids from *Oenothera* (*biennis* \times *rubricalyx*) \times *ammophila* and *O. ammophila* \times (*biennis* \times *rubricalyx*) and their cytological peculiarities. The chromosome linkages appear to be a means of explaining the genetical behaviour observed in these forms. The reciprocal F_1 hybrids are very different. They are patroclinous, *O. (biennis* \times *rubricalyx*) \times *ammophila* especially showing the peculiar leaning stems and bent stem tips of *O. ammophila*. The *rubricalyx* character—an excess of anthocyanin in various parts—is dominant in all crosses. The F_1 generation of *O. (biennis* \times *rubricalyx*) \times *ammophila* contained two types which differed in having light and dark green leaves. In F_2 , two families were erect, uniform, and resembled *rubricalyx*, while the third family segregated into two types : A, which agreed with the dark green F_1 plants, except in the presence of erect stems ; and B, having light green leaves and bent stems. In F_3 , F_4 and F_5 these types bred true in essentials. The F_1 generation of *O. ammophila* \times (*biennis* \times *rubricalyx*) contained a single type (B_1) which was erect, but possessed the grey-green leaves of *O. ammophila*. In F_2 , three families bred true and two segregated into types A and B, which resembled the original parents of the cross. In later

generations the A type bred true, B plants produced B and A, and B₁ families bred true. Further, when the A and B types were crossed together they produced an F₁ of A and B plants.

The cytological aspects of this problem were also investigated. In the case of the hybrid *Œ. ammophila* × (*biennis* × *rubricalyx*) a ring of eight chromosomes was obtained as well as three bivalents. Most usually the three bivalents took the form of rings, while the closed chain was much contorted and twisted to enable it to lie in the nuclear cavity. At metaphase, adjacent chromosomes became attached to the fibres of the spindle and the three free pairs of chromosomes took up their position about the equatorial region of the spindle. At anaphase the three bivalents assorted in the usual way, each chromosome travelling to the opposite pole of its homologue. Fairly frequent instances of non-disjunction and lagging of chromosomes were observed, as well as fragmentation at anaphase.

In the case of the reciprocal hybrid, *Œ. (biennis* × *rubricalyx*) × *ammophila*, a small ring consisting of a single pair of chromosomes was cut off from the spireme very early as the knot from the second contraction loosened out. When further unfolding of the knot took place, six further rings were set free. When the bipolar spindle was formed, as a rule most of the bivalents came to lie near the equatorial region. They never, however, formed a regular equatorial plate. Usually some of the bivalents approached the centre of the spindle and the mates separated, whilst the other homologues were still joined. This resulted, as a general rule, in a very irregular metaphase and anaphase. As the metaphase was so irregular, it is clear that the univalents comprising each separate group of chromosomes could not travel simultaneously to the opposite poles. Once the homologues broke apart they separated rapidly, but the univalents which compose each daughter nucleus would travel to the poles in a procession.

In the cross *Œ. (biennis* × *rubricalyx*) × *ammophila* at diakinesis seven bivalents were always observed. It was quite otherwise with the cross *Œ. ammophila* × (*biennis* × *rubricalyx*). In a few pollen mother-cells the amount of chromosome linkage was found to be abnormal. In one case, four bivalents and a closed

chain of six chromosomes were seen. Another abnormal configuration was a ring-pair and twelve chromosomes in a closed chain.

It will be seen that although the chromosomal constitution of these reciprocal hybrids is the same, yet differences in morphological structure and cytological behaviour is very evident. When *Æ. ammophila* is the pollen parent, each chromosome of the two groups which are brought together finds a mate, with which it becomes paired. In the case of the reciprocal cross, on the other hand, when what must be regarded as virtually the same chromosomes are brought together, only six of them pair, the other eight remaining linked in a ring. It would seem then, that some important part must be played by the cytoplasm, which is derived from *Æ. (biennis × rubricalyx)* in one cross and from *Æ. ammophila* in the other. When the cytoplasm of the egg is contributed by the constant hybrid *Æ. (biennis × rubricalyx)*, 100 per cent. pairing occurs, but when *Æ. ammophila* is the seed parent then eight of the chromosomes remain linked.

Lathræa. The meiotic phase in the pollen mother-cells of two species of *Lathræa* (*L. clandestina* and *L. squamaria*) has been investigated by Gates and Latter. All five species of this genus are root parasites of different trees and shrubs. It was found that the pollen development in these two species was very similar at all stages and that the haploid number of chromosomes was 21 and the diploid 42. This possibly represents the hexaploid condition; the fundamental number being 7. It was discovered that the method of chromosome reduction does not conform precisely to either telosynapsis or parasynapsis.

The pollen mother-cells show nuclei with a spherical, deeply-staining nucleolus. The latter contains vacuoles and crystal bodies. The reticulum is granular in appearance, and at the first onset of synapsis this granular appearance of the reticulum is lost and a delicate thread-like structure is revealed in its place. Held in the meshes of the reticulum are dense aggregations of chromatin (Fig. 77, A), the appearance of which is the first indication of approaching synapsis. These homogeneous bodies are not pro-chromosomes, but are definitely parts of the threads themselves, and are included in the synizetic knot as contraction proceeds.

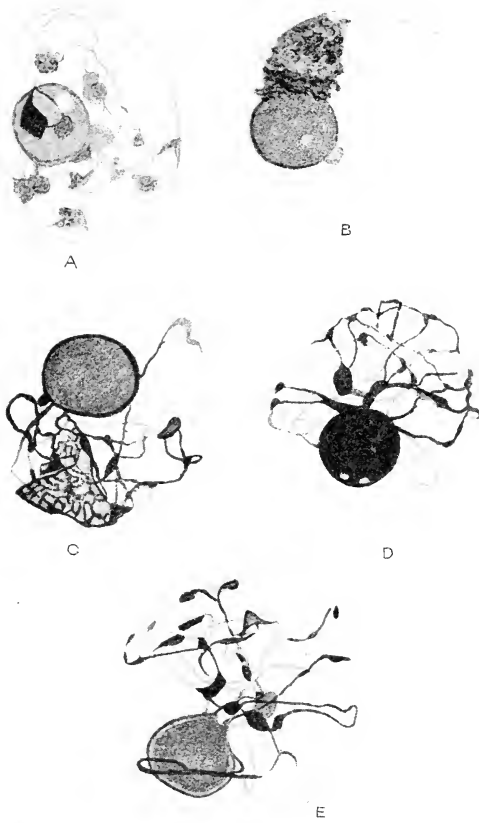

FIG. 77.—Microsporogenesis in *Lathraea* (A) *L. clandestina*. Presynizetic nucleus with chromatin aggregations held in meshes of reticulum. (B) Synizetic knot. (C) Loosening of synizetic knot. (D) Further loosening of knot. Thickened portions of thread can be seen in contact with nucleolus. (E) *L. squamaria*. Formation of chromosomes on reticulum. (After Gates and Latter, *J. Roy. Micr. Soc.*)

When contraction of the reticulum has reached its maximum the synizetic knot is extremely condensed (Fig. 77, B), and large masses of densely-staining homogeneous material are present in the knot. At the initiation of the late synaptic stages, the change from the granular appearance of the reticulum to that of a well-defined thread is very marked (Fig. 77, C). As the knot loosens out, it can be clearly seen that the chromatin is unevenly distributed along the thread, and also that the latter remains in constant association

with the nucleolus. When every trace of the synizetic knot has disappeared, the branched loops of the thread lie on one side of the nucleolus, apparently radiating out from it (Fig. 77, D). Those

portions of the thread in direct contact with the nucleolus display heavy chromatin thickenings in contrast with the fine thread of the more remote parts. This condition suggests a transference of substance from the nucleolus and its utilisation in thread formation; the near threads being much thickened by the extruded material. The nuclear condition in Fig. 77, D, is not composed of separate loops lying free from one another, but is the still continuous reticulum. This reticulate condition of the post-synizetic thread has not been previously recorded in plant cytology. At a slightly later stage in nuclear development the thread becomes more evenly distributed throughout the nuclear cavity, and the chromatin thickening is nearly uniform over the reticulum.

The method of chromosome formation is not typical of either para- or telo-synapsis. The first indication of chromosome formation is the appearance of small chromatic beads upon the reticulum, while the thread between the aggregations is very delicate and pale-staining. The chromatin aggregations are irregularly distributed upon the reticulum (Fig. 77, E), and show great variations in size. It was found impossible to say definitely whether a single aggregation represents a future bivalent or univalent chromosome. Chromosome formation takes place by the flowing together of the chromatin on the post-synizetic reticulum. After a time the threads joining these aggregations are absorbed and the bivalents become independent of one another.

The method of chromosome formation eventually falls into line with that typical of telosynapsis. The homologous chromosomes of several pairs can be seen connected end-to-end—in some cases from their free ends—and a severed strand projects, indicating incomplete absorption of the reticulum on which they were formed.

According to Gates and Latter, the chromatin aggregations shown on the reticulum indicate that neither a para- or telosynaptic scheme of reduction is in force in these forms. In the earlier stages there is no pronounced parallelism of the reticulum to be observed, but in early diakinesis there is union of certain homologous chromosomes in telosynaptic formation. Thus, though a tendency to ultimate end-to-end union of homologues is evident, the method of pairing on the reticulum may take an inter-

mediate position between the two schemes. The maintenance of a reticulum throughout the post-synaptic stages and subsequent formation of chromosomes on this reticulum structure, with omission of the pachynema stage, indicates a lowly type of nuclear specialisation, which may perhaps be correlated with the parasitic nature of the plant. The nuclear behaviour of *Lathræa* suggests that in the course of nuclear evolution some similar method of chromosome formation may have existed, and that a specialised spireme was evolved later with the consequent para- or telosynaptic pairing of the constituent chromosomes.

Brachymeiosis. The nuclear life-cycle of the Ascomycetes has for a number of years been a matter of acute dispute. The fusion of two nuclei in the ascus was first observed by Dangeard many years ago, and was considered by him to be a true sexual act. The matter, however, soon became complicated when Harper, followed by a number of investigators, claimed that a fusion also occurred at an earlier stage in the life-cycle. This preliminary fusion was stated to occur in the archicarp after the entrance of the male nuclei from the antheridium. In those forms in which the antheridium was functionless, or even absent, the fusion of two female nuclei (*Humaria granulata*, Blackman and Fraser), or even two vegetative nuclei (*Humaria rutilans*, Fraser) was described. This earlier fusion was then considered to be the true sex act and the fusion in the ascus vegetative in nature. Following the fusion in the ascus, there are three nuclear divisions in these forms, leading to the production of eight daughter nuclei which form the nuclei of the ascospores. The first division is heterotypic and the second homotypic, and some years ago Fraser put forward the claim that the third division was also a reducing division, and termed it a "brachymeiotic" division. If there be two fusions in the life-cycle of these forms it is clear that there must be two reducing divisions, and Fraser was the first investigator to bring forward evidence of such a second reduction. Following on this alleged second reducing division, other workers in Fraser's laboratory also claimed to have seen such a brachymeiotic division.

The first opposition to such a view came from Claussen, working with the discomycete *Pyronema confluens*. In an admirable paper

he showed the entrance of male nuclei from the antheridium into the oogonium through the trichogyne, and ascertained that there was no fusion of the male and female elements at this stage. The nuclei, however, paired, and when the ascogenous hyphæ were budded out from the oogonium, these pairs or synkaryons passed up the ascogenous hyphæ. The usual crozier formation occurred, and the two nuclei divided, walls were laid down and the penultimate cell contained two nuclei. The only fusion in the life-history was the fusion of the two nuclei in the penultimate cell. The three divisions in the ascus followed, the first was heterotypic and the second homotypic. The third was not brachymeiotic, but a purely equational division with no further reduction in the number of chromosomes. Claussen considered that the presence of so-called "fusions" in the earlier stages was due to poor fixation, and that some of the nuclei were in a pathological condition. Therefore, on these grounds, the figures described by the brachymeiotic school as "fusions" are regarded as purely artifacts. Practically without exception, the papers which subsequently followed this work placed the same interpretation on the nuclear phenomena displayed by the Ascomycetes, and since there was no early fusion in the life-history the necessity for a second reduction became unnecessary, and Claussen's synkaryons placed this group on the same footing as the Uredinales.

More recently Bagchee has followed essentially the same interpretation for the ascomycete, *Pustularia bolarioides*. Only the divisions in the ascus were examined. The first heterotypic division was found to follow the telosynaptic scheme of reduction. The diploid number of chromosomes in this form are 32, and 16 bivalents made their appearance at prophase of the first division. In the next two divisions 16 chromosomes could be counted, *i.e.*, the third division was purely vegetative and not brachymeiotic.

A somewhat curious compromise has been arrived at for the form *Pyronema domesticum* by Tandy. He was able to confirm Claussen's description of the general sexual process. This species, like *P. confluens*, possesses both an oogonium and an antheridium. The entrance of the male nuclei was a fairly prolonged affair, and the claim is made that at the fringes of the oogonium fusion of

male and female elements took place. Ascogenous hyphæ were budded out in the usual way from the oogonium, and when their tips bent over to initiate the young asci, simultaneous division of the nuclei took place. In some of them the nuclei showed 7 chromosomes on the spindle at metaphase and 14 (7 to either pole) at anaphase, *i.e.*, the haploid number. In others, 24 chromosomes were counted at metaphase, and 20 could be counted on their way to the poles, *i.e.*, the diploid number. Thus the third division might or might not be brachymeiotic. It is therefore suggested that sometimes a fusion of male and female elements takes place in the oogonium, and if such has occurred, then the third division will be brachymeiotic in nature. On the other hand, fusion may not take place and the third division will then be vegetative. Tandy has suggested that *P. domesticum* represents a transitional form among the Ascomycetes.

SEX-CHROMOSOMES

That sex is controlled by special chromosomes has been known for some times in the case of animals, and the matter has been very extensively investigated by animal cytologists. In the case of plants, however, their discovery is of very much more recent date.

In plants a large variety of sexual conditions are exhibited. Sharp, following Blakeslee, distinguished the following: *homothallic* plants, *i.e.*, those manifesting the two sexes in the same gametophyte or thallus, and *heterothallic* plants, those manifesting sex in different gametophytes. *Heterophytic* plants are those in which two kinds of spores, with male and female tendencies respectively, are borne by separate sporophytes. *Homophytic* plants are those in which a single sporophyte bears the two kinds of spores, with male and female tendencies respectively, or spores of one kind with a bisexual tendency. Thus the Bryophytes are all homophytic, but they may be either homothallic or heterothallic. Seed plants, on the contrary, are all heterothallic, but they may be either homophytic or heterophytic.

It was among the Bryophytes that evidence was first forthcoming that sex was bound up with meiosis. The Marchals, for example,

found in certain mosses that two kinds of spores are produced in equal numbers in the sporogonium, and that these spores develop into male and female plants respectively. These workers were quite unable to alter experimentally the sexes of the gametophytes. Very similar results to these were obtained by Schweizer for *Splachnum sphaericum*, and by Fleicher for some other genera of mosses. Here again the spores were of two sizes, large and small. The large apparently gave rise to female plants and the small to male.

The suggestion that sex-chromosomes were present in unisexual Angiosperms was first made by Blackburn and Harrison for *Populus* at the Hull meeting of the British Association. Only the chromosome complement of the pollen was investigated and the XY condition was suggested to be present. Later, however, Blackburn investigated both the male and female side in *Melandrium*, and found the male to have the XY composition and the female XX.

The most important case among Bryophytes, is that of *Sphaerocarpus*. It was first

shown by Strasburger that the spores of a single quartet give rise to two male and two female plants. Ten years later Allen demonstrated the presence of the first sex-chromosomes in plants. In *S. Donnellii* the sporophyte has eight pairs of chromosomes, including an unequal XY pair. At the heterotypic division of meiosis, this XY pair separate and then divide longitudinally at the homotypic division. The two spores receiving the X-chromosome develop into female plants, while those receiving the Y-chromosome give rise to male plants. Schäcke has demonstrated the same situation in *S. taxanus*.

The problem of sex-chromosomes in plants has now been much investigated to the Angiosperms, and their presence has been demonstrated in a number of heterophytic species.

Santos has investigated the case of the unisexual plant, *Elodea*. The nuclei of the somatic tissues contain 48 chromosomes. At



FIG. 78.—Chromosome sets from male and female gametophyte of *Sphaerocarpus*. (After Allen, from Sharp, *Introduction to Cytology*.)

meiosis, 24 bivalents emerge from the second contraction ; they undergo considerable condensation, until they acquire a more or less definite form and the 24 pairs include an XY pair which are of unequal size. At metaphase each of the bivalents is attached to the spindle by one end and the two constituent elements move apart. The X-chromosome is considerably larger than the Y-member, and they pass to the opposite poles of the spindle. The second division is equational, so that the pollen grains are of two kinds, two with nuclei containing an X-chromosome and two

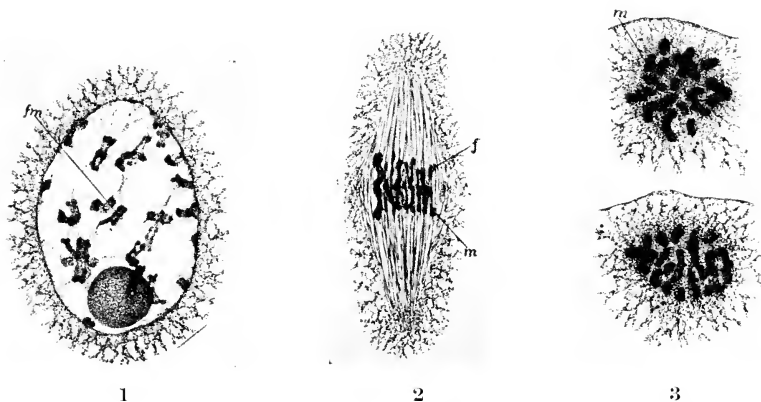

FIG. 79.—Microsporogenesis in *Elodea canadensis*. (1) Diakinesis, showing unequal chromosome pair, *fm* (XY). (2) Beginning of anaphase, X and Y disjoining (*f* and *m*). (3) Metaphase, showing X and Y (*f* and *m*). (After Santos, *Bot. Gaz.*)

with the Y-chromosome. In the female plants, the nuclei contain the elements XX and in the male plants contain an XY pair.

Correns showed in *Rumex acetosa*, that the staminate plant was disporic and that there was a very considerable difference in the rate at which the pollen tubes carrying male and female determining gametes grow down the styles. Later the matter was carried further by Kihara and Ono, who showed that in the staminate plant the somatic number of chromosomes is apparently 15. In the case of the microsporocytes there are six gemini and a triple group composed as follows : a large chromosome (M-chromosome) and a smaller member attached one to either end (m_1 and m_2).

During the heterotypic division of meiosis M disjoins from m_1 and m_2 , and at the homotypic division all three split longitudinally, and thus two of the microspores receive seven chromosomes (six autosomes and M), and the other two receive eight chromosomes (six autosomes and m_1 and m_2). The somatic nuclei of the female plant contain twelve autosomes and two M -chromosomes.

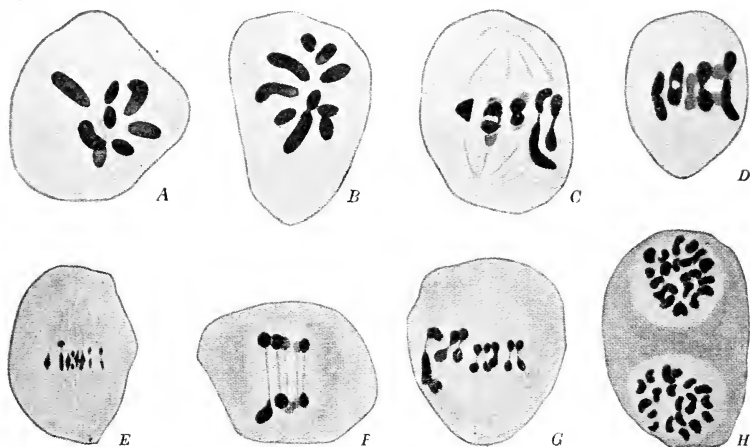

FIG. 80.—Sex chromosomes in heterophytic Angiosperms. (A) *Vallisneria spiralis*, showing eight autosomes. (B) *V. spiralis* showing eight autosomes and one long constricted X-chromosome. (C) *Melandrium album* showing XY pair about to disjoin. (D) *Humulus japonicus* showing XY pair on right. (E) *Populus balsamifera* with XY pair. (F) *Vallisneria dioica* showing X and Y disjoining at first division. (G) *Rumex acetosella* showing Mm disjoining from m at first division. (H) Polar view of the same. (A-D after Winge, E-H after Meurman. From Sharp, *Introduction to Cytology*.)

Thus at fertilisation with a male gamete carrying M , the result will be a female plant, and fertilisation with a male gamete carrying m_1 and m_2 will give rise to a male plant. Kihara and Ono considered that the M -chromosome is equivalent to X and that the m_1 and m_2 elements compose the Y -chromosome. Meurman reported a similar state of affairs for *R. thyrsiflorus*, but according to this author in *R. acetosella*, M and one of the m 's disjoin from the other m at the first meiotic division.

In the genus *Melandrium* the presence of sex-chromosomes was independently discovered by Blackburn and Winge. These workers reported that an unequal pair of XY chromosomes are present in the staminate plant and that the members of this pair disjoin at the heterotypic division in the microsporocytes. In the carpellate plant Blackburn described the presence of an XX-pair. She also found the same state of affairs in *Lychnis dioica* and in the hybrid *L. alba* \times *L. dioica*. In this case Blackburn is of the opinion that the larger and not the smaller member of the pair represents the Y-chromosome.

The presence of sex-chromosomes has now been reported in the genus *Humulus*. Winge described in both *H. lupulus* and *H. japonicus* the somatic number of chromosomes in the male plant as 20. This number is made up of 18 autosomes and an XY-pair of chromosomes. The X-member of the pair can be readily distinguished from the Y-member by its larger size and the presence of a constriction in the middle. At meiosis this XY-pair disjoin and at the second division they divide longitudinally. The question of sex-chromosomes has been further investigated by Kihara in *H. japonicus*. Here there are 17 chromosomes in the male and 16 in the female plant. In the male plant the 17 chromosomes are made up of the following, 14 autosomes and 3 sex-chromosomes. One of these is large and V-shaped, and is presumably the X-chromosome, while the other two are J-shaped and comprise the Y-chromosome, made up of a pair (y_1 and y_2). The sex-chromosomes here are very large and larger than the largest autosomes. In the female plant the two X-heterosomes are large and V-shaped structures. At meiosis of the pollen mother-cell, the sex-chromosomes form a tripartite complex of which the central X-chromosome passes to one pole of the spindle and y_1 and y_2 pass to the other. The behaviour of the sex-chromosomes is therefore identical with that of the corresponding stages of *Rumex acetosella*. The chromosomal formulæ of these plants are given as follows :

| | | | |
|----------------------|---|---|--------------------------|
| Staminate (diploid) | . | . | 14 + X + y_1 + y_2 |
| „ (haploid) | . | . | 7 + X, 7 + y_1 + y_2 |
| Carpellate (diploid) | . | . | 14 + X + X. |

| | | | | | | | |
|----|---|---|---|---|---|---|------------|
| 4n | . | . | . | . | . | . | Tetraploid |
| 5n | . | . | . | . | . | . | Pentaploid |
| 6n | . | . | . | . | . | . | Hexaploid |
| 8n | . | . | . | . | . | . | Octoploid |

All plants with a higher chromosome number than $2n$ are termed *polyploids*. Polyploids are divided into two classes according as their different sets of chromosomes are derived from the same species, in which case they are termed *autopolyploids*, or from different species, when they are known as *allopolyploids*. The genetics of the two classes is very different.

The earliest experimental case of polyploidy was that of *Oenothera gigas*, which was first recorded by Gates and Lutz some years ago. This plant is a tetraploid mutant and is a cell giant. It was first suggested that this mutant owed its origin to a longitudinal split in the chromosomes at division of the fertilised egg, a view opposed by de Vries, who considered that it arose through the union of two diploid gametes. Bridges has termed the doubling of the diploid number of chromosomes by the process of splitting and non-separation, "non-division." It has generally been thought that such a process occurs most frequently in the zygote, with the result that a tetraploid individual is produced. The actual evidence for such a view is only indirect, but nevertheless very strong. De Litardière, for example, found in *Spinacia oleracea* not only somatic cells with 12 chromosomes, the normal number for this species, but also cells with 24 and 48 chromosomes. As a general rule the daughter chromosomes remained closely associated at prophase and separated normally at anaphase, but in other cells they became independent and underwent a second splitting process, with the result that 24 chromosomes passed to either pole of the spindle.

A doubling of the chromosome number through nuclear fusion may also occur. Gates has reported such a case for *Oenothera*. The nuclei may apparently fuse during the telophase of the homotypic division of mitosis. Similarly Blackburn and Harrison found one giant spindle instead of two normal ones in the second sporocyte division of *Rosa*, thereby showing that the mitotic figures may unite. Winkler has reported tetraploidy in graft

hybrids of *Solanum* due to the fusion of nuclei in adjacent cells near the wound.

Among tetraploid wild species, the case of *Spiranthes cernua* perhaps comes nearest to that of *Oenothera gigas*. This species is widely distributed in North America and is stouter in all its parts than related forms, and is apparently a cell giant. In the genus *Primula* (see below), cell-gigantism can occur either with or without polyploidy. Thus the simplest form of tetraploidy appears to be that in which chromosome doubling is accompanied by an increase in the volume of the nuclei and cells.

The whole question of size relations between chromosomes, nuclei, cells and organs of polyploid species requires further investigation, in order to analyse completely the nature of the changes which have occurred in each case. These size relationships vary very much in different genera. Thus in *Trifolium*, species are to be found with the same chromosome number, yet the chromosomes may differ in size. Also in this genus there appears to be no direct relationship between chromosome number and plant size, but there is such a relationship between cell size and plant size. Thus in *T. campestre* and *T. glomeratum*, which have the same number of chromosomes ($n = 7$), the chromosomes are also approximately the same size. *T. arvense* and *T. pratense* have the same number of chromosomes, but these differ in size. In *T. repens* the number of chromosomes has been doubled ($n = 14$), yet the size of the chromosomes remains about the same as that of related species. In *T. minus* the chromosome number is again tetraploid ($n = 14$), but the chromosomes are smaller and may have arisen through transverse segmentation. Lastly, in *T. pannonicum*, the chromosome size is the same, while the chromosome number is 14.

In the tetraploid form of *Primula sinensis* there are 48 chromosomes, the diploid plant having 24. About thirty factors are now known causing variations in the diploid, and nine of these also occur in the tetraploid plant.

The genetical behaviour of these forms differs in three ways. Thus the recessive factor, which causes intense crimping of the leaves and flowers in the diploid, has a very much less intense effect

in the tetraploid species. Again, intermediate forms are possible in the tetraploid plant which are not found in the diploid. The most important differences relate to the laws of segregation and inheritance. Only one kind of heterozygote is possible in the diploid. In the tetraploid, on the other hand, three kinds are present. The genetics of plants heterozygous for several factors, especially when these are linked, is very much more complicated, but agrees with expectations if the factors be associated with definite loci in the chromosomes.

The conditions present in the allopolyploid are very different. For example, in the cross between *Primula floribunda* and *P. verticillata* a sterile hybrid has several times been obtained. This problem was investigated by Newton and Pellew, who have shown that the hybrid, which contains one set of nine chromosomes from each parent, can become fertile by throwing tetraploid branches. The seedlings produced from these branches are the well-known *Primula kewensis*. Here there are nine sets of four chromosomes, which may be called $F_1F_1V_1V_1$, $F_2F_2V_2V_2$, and so on, the *floribunda* chromosomes being called F_1F_2 , etc., and the *verticillata* V_1V_2 , etc. These chromosomes generally unite in pairs, and not in fours, and since the plant breeds nearly true, it is assumed that F_1 generally pairs with F_1 and V_1 with V_1 , and so on. Thus each gamete will have the composition $F_1V_1F_2V_2$, etc., and the plant breeds true. Occasionally, F_1 pairs with V_1 , and offspring different from the parent will be produced. Several other fertile and constant inter-specific hybrids are similarly allotetraploids, and it is probable that this is one method whereby new species arise in nature.

Triploids. It has generally been considered that triploids have arisen by the union of a diploid gamete with a haploid one. Certainly triploids have been produced by crossing tetraploid mutants with diploid species. Another possible origin for triploids is the entrance of two male nuclei into the egg (dispermy). Such a process has been recorded by Ishikawa for *Oenothera*.

In *Hyacinthus* de Mol observed that diploid plants on occasion produced a few functional diploid pollen grains. This result was apparently due to the shortening of the growing season and was a

physiological response. When diploid varieties were pollinated with such grains, a few triploid plants were obtained among a good many diploid ones. According to de Mol, abnormal physiological states possibly play a larger rôle than has generally been allowed in causing chromosome doubling in other genera. The actual mechanism at work in *Hyacinthus* still awaits discovery.

Haploids. It will be convenient here to consider the question of haploids, although strictly speaking such plants do not belong to such a discussion as this. The appearance of haploid individuals among diploid forms is very rare. The first known case of such a phenomenon in Angiosperms was found by Blakeslee and his co-workers in 1922 for *Datura stramonium*. They have since obtained several such plants. They were of very much weaker growth than the diploid forms, but these workers succeeded in growing them to sexual maturity. Later, Clausen and Mann reported the presence of two haploid plants in their *Nicotiana tabacum* hybrids. Gates has also recorded a single haploid *Oenothera* among his cultures. This plant occurred among the F_1 hybrids. Reciprocal crosses were made between *O. rubricalyx*, and *O. eriensis*, both of which have 14 chromosomes. *O. eriensis* \times *O. rubricalyx* gave a uniform F_1 generation, with the red pigmentation of *rubricalyx* and the flowers of *eriensis*. These bred true in F_2 . The reciprocal cross, *O. rubricalyx* \times *O. eriensis*, made at the same time, produced seedlings yellowish in colour and which developed little chlorophyll and then promptly died when their stored food was used up. The striking non-viability of this cross led to its repetition, with the same result. From another capsule, obtained by crossing different individuals of the same two species, 85 seedlings were obtained, which also behaved in the same way, with the exception that two of the seedlings survived for a time and one was planted out. The latter reached maturity and belonged to a new type. It was very much dwarfed and completely sterile as regards pollen and seed production. This plant proved to be a haploid and possessed seven chromosomes in its somatic cells. It showed the red pigmentation of *rubricalyx*. Its leaves were narrow and rather pointed, and these were at first thought to be characters belonging to *eriensis*, but they are more

probably characters pertaining to haploid *rubricalyx*. It is suggested that this haploid mutant developed parthenogenetically from a *rubricalyx* egg under the stimulus derived from the foreign pollen tubes of *eriensis*. Other *Oenothera* haploids have recently been described by Kulkarin and Davis and by Emerson.

Aneuploids. These are forms which have somewhat more or less than the diploid number of chromosomes; the number not being an exact multiple of the basic haploid number. Aneuploids as a general rule differ very much more from the normal diploid form than do tetraploids, triploids, etc. Aneuploids with extra chromosomes (hyperploids) are of common occurrence, but the corresponding hypoploids are rare. The best known aneuploids contain one more than the diploid number of chromosomes ($2n + 1$). These are called *trisomies*, and are best exemplified by *Oenothera lata*, *O. scintillans*, *O. oblonga*, etc., and by the *Datura* mutants since investigated by Blakeslee and his associates.

In *Datura stramonium*, which has been investigated by Blakeslee, Belling and their co-workers, it was found that the haploid number of chromosomes was 12. The make-up of these 12 chromosomes was as follows: one very large, four large, three large medium, two small medium, one small and one very small. The haploid mutants have one such set, normal diploids two, triploids three and tetraploids four. In addition to these polyploids, a considerable series have been discovered with the complement, $2n + 1$. Other types have also been recorded, e.g., $2n + 1 + 1$, $2n + 2$, $4n + 1$, and $4n - 1$. The unbalancing effect of this extra chromosome is shown in the so-called "globe" mutants. It was found that the $2n + 2$ globe has the characteristics of this mutation more developed than the $2n + 1$ mutant, and the same is true of the $4n + 2$ type compared with the $4n + 1$ type. In each case the degree of nuclear unbalance was reflected in the somatic appearance of the plants. It was also found that the $2n + 1$ mutants, both in *Datura* and *Oenothera*, differed in their external appearance, as well as in their anatomical structure from the diploid form. More recently Blakeslee and Belling have reported the appearance of so-called "chromosomal chimeras," in which

single branches of diploid plants showed $2n + 1$, $2n - 1$, or $4n$ chromosomes.

Higher Polypleids. Given triploid and tetraploid forms, the higher multiples may be derived from them. A hexaploid, for example, may arise by the doubling in a triploid hybrid through non-division in the zygote or by the union of triploid gametes. Blackburn and Harrison have investigated the genus *Rosa* in this respect. *R. pimpinellifolia* contains 14 chromosomes in the female gamete. This was crossed with *R. tomentosa* (male gamete with seven chromosomes). The resulting fertile plant was *R. Wilsoni* with 42 chromosomes, instead of a plant with the expected 21. Here hexaploidy has resulted from a doubling in a hybrid between a tetraploid and an unbalanced pentaploid. This question of higher polypleids will be discussed in more detail for cereals.

Polypleidy in the Graminæ. In wheat, barley, oats and rye the basic chromosome number is seven. All cereal barleys and rye have 14 as the diploid number of chromosomes in their somatic cells. In the case of oats and wheat, three distinct classes are now known: (1) diploid species with 14 chromosomes, tetraploid with 28 chromosomes, and (3) hexaploid forms with 42 chromosomes.

Taking the case of oats first, three of the diploid species, *Avena brevis*, *A. stigosa* and *A. nuda*, have but a limited economic use, and a fourth diploid species, *A. Wiestii*, has no economic value. It is the hexaploid species *A. sativa* that is of the greatest economic importance, but two other hexaploid species, *A. byzantina* and *A. fatua*, are useless from the economic standpoint. Similarly in the wheats, the diploid species *Triticum monococcum* is of no economic importance. Of the six tetraploid species, *T. durum*, *T. turgidum*, *T. polonicum*, *T. dicoccum*, *T. persicum*, and the wild species *T. dicoccoides* are very important agricultural plants, while the rest have but little economic use. Again, as in the genus *Avena*, it is among the hexaploid species that the most useful wheats are found, e.g., *T. vulgare* and *T. compactum*. The species *T. Spelta* is also hexaploid, but has practically no agricultural value.

Although it is clear that the chromosome number does not determine the economic importance of cereal species, it is equally

clear that the duplication or multiplication of chromosome number has played a large part in the evolution of the species of wheat and oats and is of the greatest use in agriculture.

The hexaploid species of both oats and wheat behave cytologically and genetically like simple diploids, *i.e.*, when the germ-cells are formed, the 42 chromosomes pair to give 21 bivalents. It has usually been assumed that the hexaploid species have been formed by the reduplication of the chromosome set of one original diploid species, *i.e.*, by autopolyploidy, and that the present wide diversity of hexaploid cereals, as well as the differentiation of their chromosomes which causes them to form 21 pairs instead of seven sets of six, has been brought about by gene mutation subsequent to the doubling. According to Huskins this is an improbable state of affairs, and their diversity and behaviour are just what would be expected if they had arisen by allopolyploidy. The hexaploid species have probably arisen by two steps. In the first stage there was hybridisation of two diploid species followed by chromosome doubling to produce a tetraploid form and then the hybridisation of this or similar tetraploids with diploids. This again, followed by chromosome doubling, led to the hexaploid species.

Nilsson-Ehle and other workers have discovered that different varieties of wheat may have one, two or three pairs of factors for red colour of grain. It has also been shown by Akerman that three independent pairs of factors affect the development of chlorophyll in oats. In wheat it appears that head-type, dwarfing and chlorophyll development may be determined by one, two or three pairs of factors, and that the production of awns and hairs and the winter or spring habit of growth, by either one or two factors. In oats there is good evidence of as many as three pairs of factors affecting grain colour and ligule development and of two pairs affecting pubescence and side or open type of panicle. This is in marked contrast to the condition exhibited by barley and rye, in which duplicate factors are rare and single factor differences common.

These duplicate factors may arise in a diploid either through parallel gene mutation in different chromosomes or through

duplication of parts of chromosomes, but the simplest and most plausible explanation of the common occurrence of duplicate factors in tetraploid and triplicate factors in hexaploids is that they were present in the original diploid species, and have been brought together in the cultivated cereals by allopolyploidy.

The speltoid and fatuoid mutations of wheat and oats seem to be clear cases showing the effect of polyploidy in producing mutations. Their appearance in cultivated varieties of wheat and oats is correlated with chromosome aberration. Different genetic types of these mutants, all similar in appearance, may apparently arise, as Huskins has shown, through the interchange of a pair of chromosomes, or through gain or loss of a chromosome, and the heterozygous mutant form can therefore be obtained with 41, 42 and 43 chromosomes. The "homozygous" mutant types segregated from these have 40, 42 and 44 chromosomes respectively, and by making the appropriate crossings or through further chromosome aberration they can be obtained with 41 and 43 chromosomes also. These results are explicable if the characters of cultivated wheat and oats involved be determined by the interaction of rather distinct pairs of factors, situated on similar (but not identical or truly homologous) chromosomes which have been brought together by allopolyploidy. The mutant form will then probably arise whenever the balanced interaction is disturbed.

Age apparently plays a part in the production of mutant forms, especially of speltoids and fatuoids. Some of the oldest European varieties of oats very rarely produce fatuoids, but these are of frequent occurrence in forms of recent origin. Hybrids between hexaploid species or even varieties of cereals sometimes have irregular chromosome behaviour, and the crossing of varieties may introduce aberrations in later generations. This is to be expected if they be allopolyploids.

One of the most important features of work on speltoids and fatuoids in cereals in connection with polyploidy bears on the effect of the latter in hiding harmful mutations and also on the problem of the origin of dwarfs. Fatuoids or speltoids with 41 instead of 42 chromosomes are almost as vigorous as normal plants. The production of grains, however, in such plants is much below normal,

and any 40-chromosome progeny from them are usually dwarf and sterile. If such plants occur in cultivated varieties, they must reduce the yield to a certain extent. Their occurrence is directly attributable to polyploidy, as in diploid species chromosome aberrations are not of such frequent occurrence.

Further support for the view that cultivated wheat and oats are allopolyploids comes from the work of Tschermak and Bleier. They investigated crosses between *Ægilops ovata* \times *T. dicoccoides* and *Æ. ovata* \times *T. durum* (each of which has 28 chromosomes). They obtained new fertile forms with 56 chromosomes, which they have named *Ægilotricum sp.* Another point in favour of the hypothesis that wheat and oats are allopolyploids is the fact that most of their characters are found, in whole or part, in species with lower chromosome numbers. This last can be explained by assuming that parallel mutations have occurred in different species. But hybridisation, followed by chromosome duplication as the evolutionary mode of these genera, affords a simpler and more plausible explanation.

Gregor and Sansome have described, within the species *Phleum pratense* L., two intersterile groups of ecological significance. Within each a relationship was found to exist between the growth-forms of a particular habitat and the environmental conditions of that habitat. The authors are of the opinion that the survival of these growth forms is dependent on their genotypic response to the environmental conditions of the habitats which they occupy. The cytological examination shows that Group I is hexaploid ($2n = 42$), while Group II is diploid ($2n = 14$). Two chromosome groups ($2n = 14$ and 28 respectively) have also been found in *P. alpinum* L. The cross *P. pratense* $2n \times P. alpinum$ $4n$ gave plants with a $3n$ number of chromosomes. These hybrids were almost completely sterile, but gave rise to four hexaploid plants. Group I $\times P. alpinum$ $4n$ gave one sterile $5n$ plant. Fertile hybrids have now been obtained from the artificial hexaploid \times the natural (Group I) hexaploid. It is tentatively suggested that Group I ($6n$) may be the result of natural hybridisation of *P. pratense* Group II ($2n$) with some other plant, in a manner analogous to that for the artificially produced hexaploid, which

resulted from the doubling of the chromosomes in gametes of the hybrid between *P. pratense*, Group II (2n) \times *P. alpinum* 4n. Whether or not this surmise is correct will depend on future work, but it can be stated definitely that the gap between *P. pratense*, Group I (6n) and Group II (2n) has been successfully bridged by the employment of the tetraploid form of *P. alpinum* L. Although the *P. alpinum* polyploid may only represent the duplication of chromosome sets within the diploid form, it, nevertheless, constitutes an important ecological and evolutionary unit.

Polyploidy as a Source of Species and Horticultural Varieties. Hurst has given a short record of this aspect of polyploidy, and the following account is a condensation of his paper.

Many varieties in horticulture are polyploids. These have been found in strawberries, apples, bananas, roses, sugar cane, tomatoes, dahlias, primulas, cannas, daturas, petunias, tulips, and numerous other plants. Many of these are giant forms, and on that account have an especial appeal to the horticulturalist. It is therefore clear that polyploidy is a fruitful source for horticultural varieties.

The great majority of polyploids are polyploid species. In roses, in which both allopolyploids and autopolyploids occur, over 1,006 forms have been examined, and 629 were found to be polyploids. Of these polyploids, 21 were polyploid varieties and 608 he regarded as polyploid species.

Polyploid varieties have similar sets of chromosomes and characters, which have no doubt arisen by reduplication of the sets within the same diploid species. Consequently, although their chromosome sets have increased in number, their specific characters remain the same and they differ from the diploid species whence they have been derived only in their varietal characters. Many of the garden roses known to the horticulturist are polyploid varieties, often triploid and tetraploid. Polyploid species, on the other hand, have unlike and differential sets of chromosomes and characters. They are distinct species, and they differ from one another by one or more differential sets of chromosomes and characters. At synapsis their chromosomes are either bivalents, or both bivalent and univalent. Polyploid species are found in

large numbers in the wild state, and have a wide distribution. Polyploid species have been found in the Rosaceous genera, *Rosa*, *Rubus*, *Fragaria*, *Cratægus*, *Prunus*, *Potentilla* and *Alchemilla*, and in families such as the Compositæ, Scrophulariaceæ, Solanaceæ and others, a similar state of affairs has been found to exist.

The genus *Rosa* has been investigated by a number of workers with regard to chromosome number and characters. *Rosa spinosissima* is a tetraploid species which combines the characters denominated by Hurst BB and CC of two diploid species. CC is characteristic of tortuous branches and prickly, setaceous stem, while small leaves and small bracteate singly-set flowers are denoted by BB. In size of parts, the polyploid species are very much smaller than the diploids, whereas as a general rule the polyploid varieties are larger in their various parts than the diploid. Genetical hybrids between the B and C sets of chromosomes produce plants with similar characters to those displayed by the polyploid BBCC species and demonstrate experimentally their true nature.

In the tetraploid AACC species we have numerous wild species as well as the oldest-known cultivated varieties of roses, *R. centifolia* and its subspecies *damascena* and *gallica*. These all show a combination of the characters and chromosomes of the two diploid species AA and CC. Numerous hybrids between these two diploid species show similar characters, and a detailed analysis of these provides an experimental demonstration of the nature of this polyploid species.

Some remarkable results have been recorded in the genetical tests. In the hybrid AC all external A and C specific characters appear side by side, whereas in the AACC polyploid species only about *one half* of the A and *one half* of the C characters are given expression, and these appear in relays as it were, throughout the plant. This remarkable difference between the workings of the genes in single differential sets and in double differential sets of chromosomes seems to be worth following up.

In the AAEE tetraploid species of *Rosa Davidii* we get the stout prickles and compound inflorescence of the AA species with

the graceful habit and long drooping fruits of the EE species, In the same way, although with a greater number of complications, the hexaploid and octoploid polyploid species of *Rosa* show similar combinations of the chromosomes and characters of three and four differential species respectively.

In addition to the two kinds of polyploidy—polyploidy varieties and polyploidy species—a third kind is known among roses, which is really a combination of the two. A number of garden roses are polyploid varieties of the AA species. The triploid tea rose, Lady Hillington, according to Hurst, carries three A sets of chromosomes and characters, while the tetraploid tea rose, Gloire de Dijon, has four sets of A. Most of the old-fashioned hybrid perpetual roses belong to the polyploid species carrying two sets of A and two sets of C chromosomes and characters.

Hybridisation between these two species has given rise to the modern hybrid teas, which are polyploid hybrids carrying three A sets and one C set of chromosomes and characters. So far these have only been found in cultivation, but if diploid gametes arise in cultivation through physiological disturbances due to changed conditions, there is no reason why they should not arise in nature under extreme conditions, and no doubt polyploid hybrids of this mixed type will be found in the wild state.

There is another possibility that must also be considered: Garden roses that were once polyploid varieties may have now become partially differentiated by mutations of their genes under the influence of intensive cultivation. A similar condition may arise from two species hybridising and subsequently reduplicating which were not entirely alike in their chromosome sets. In such circumstances it is to be expected that there would be a mixture of multivalent and bivalent chromosomes at synapsis. In cases of intense cultivation, the sets themselves might be formed of chromosomes from two or more different sets which had become broken up as in the heteroploid hyacinths.

The experimental creation of polyploid species is now an accomplished fact. Thus *Primula kewensis*, *Nicotiana digluta*, and the new polyploid genera *Brassico-raphanus* and *Egilotriticum* originated in controlled experiments and the details of

their origin are fully known. They arose through hybridisation of distinct species and the subsequent reduplication of their chromosomes made them fertile. It is probable that the numerous polyploid species of *Rosa* originated in this way, although the reverse process of loss of sets in polyploid species giving rise to lower polyploid species and ultimately to diploid species is believed by Hurst to be at work in the evolution of the species of *Rosa*. *R. centifolia* is one such case in point. The tetraploid species of this plant threw off as bud-sports several triploid mutants in France.

Taxonomically, polyploidy explains many difficult problems and makes clear the remarkable polymorphism of a genus like *Rosa*, in which the many sets of chromosomes and characters in the polyploids give a range of variation far exceeding that of diploids.

“Polyploidy has helped us to realise for the first time what a species really is. It has experimentally demonstrated that a species is no longer an expert opinion, but a real entity which can be experimentally demonstrated by the combined methods of taxonomy, cytology and genetics. True species are entirely discontinuous and isolated from one another by their different sets of chromosomes and characters. A knowledge of the true nature of a species clears the way for an inquiry into its origin and evolution. That polyploidy has played a great part in this is now clear. The evidence shows a rhythmic process of evolution up and down from diploid species to polyploid species by additions of sets of chromosomes, and down from polyploid species by losses of sets of chromosomes. From the experimental evidence there can be little doubt that the evolution of a species is in large measure directed and controlled by the conditions of life acting directly on the chromosome sets and the genes contained therein causing mutational responses and changes of balance which when favourable create new species.”

Sterility and Polyploidy in Cultivated Fruits. Cultivated fruits are often complex hybrids with a complex chromosome constitution. A number of our fruits are polyploids, and those with the higher chromosome number than the diploid are as a general rule

more productive, and again, those with an even number of chromosomes are better fruit bearers than those with an odd number. For example, the tetraploids, hexaploids and octoploids are more productive than triploids, pentaploids and heptaploids.

Fertility in the genus *Rubus*, for example, is closely associated with a balanced chromosome constitution. The basic chromosome number here is seven. The raspberry varieties, Superlative and Lloyd George, have 14 chromosomes, while Mahdi and Veitchberry have 21 and 28 respectively and Loganberry and Laxtonberry 42 and 49 respectively. It is a well-known fact of horticulture that the triploid Mahdi and the heptaploid Laxtonberry are poorer croppers than the even chromosome series, the diploid raspberry the tetraploid Veitchberry and the hexaploid Loganberry. Exceptions to this rule are due to apogamous development of seed.

The chances of obtaining fertile progeny from cross-breeding is largely limited by the numerical relationships of the chromosome complements. If a diploid be crossed with a tetraploid the offspring are triploid and a tetraploid crossed with a hexaploid yields pentaploids. It has been shown by Crane and others, however, that on occasion exceptional seedlings do arise from such matings. Thus when *Rubus rusticanus inermis* (diploid species) with 14 chromosomes was crossed with *Rubus thyrsiger* (tetraploid species) with 28 chromosomes, three seedlings were obtained, two of which were triploids arising from the addition of seven *rusticanus* and 14 *thyrsiger* chromosomes. The other seedling had 28 chromosomes and arose by the functioning of an unreduced egg of its mother, whereby the full chromosome complement of *rusticanus* (14) combined with the haploid complement of *thyrsiger* (14) yielded a tetraploid plant with 28 chromosomes. This tetraploid seedling proved to be highly fertile and very productive, whereas only occasional drupelets were obtained from the triploid offspring. It would seem that the Veitchberry and Laxtonberry have originated from the functioning of a gamete with the unreduced number of chromosomes. For example, the Laxtonberry was derived from the Loganberry \times Superlative and has 49 chromosomes. Here there has been a combination of the full complement of the Loganberry (42) with the haploid number of Superlative (7).

In the same way the so-called Duke cherries, which have 32 chromosomes, have arisen from the sweet cherry ($2n = 16$) and the Sour cherry ($2n = 32$) by the same kind of irregularity.

The basic chromosome number in the genus *Prunus* is 8, and here again the more fertile forms have a balanced number of chromosome, e.g., the tetraploids, hexaploids and octoploids. Crane and others have raised from the cross *P. domestica* (48) with *P. cerasifera* (16) and another cross was also made between *P. institia* (48) and *P. spinosa* (32). The offspring possessed the expected intermediate number of chromosomes, i.e., 32 and 40. The offspring of the cross between *P. domestica* and *P. institia* were hexaploid and invariably fertile, whereas the crosses between *P. domestica* and *P. cerasifera* and *P. institia* and *P. spinosa* rarely yielded fruit with viable seed.

The ornamental cherries are in the main triploids, e.g., the species *P. nana*, for their degree of sterility is too high for them to be cultivated for fruit. In families raised at the John Innes Institution from crosses between forms with 32 and 16 chromosomes respectively, a high degree of sterility has generally been obtained. This result is possibly due to the unbalanced triploid chromosome complement. A number of seedlings were examined for chromosome number and were found to have 24.

The strawberry presents an interesting case of polyploidy. The wild European strawberry (*Fragaria vesca*) has 14 chromosomes. The other species, including cultivated forms, are all polyploids. The diploid forms hybridise with great ease and give fertile offspring. In the same way crosses between octoploids also give rise to fertile offspring. As a general rule all attempts to intercross species with different chromosome numbers have ended abortively, and only sterile offspring have been obtained. Our present cultivated forms are all octoploids and probably arose by the introduction into Europe and subsequent crossing of the two octoploid species, *F. virginiana* and *F. chilensis*.

It will be seen from the short account given above that polyploidy has largely entered into the production of domestic fruits. Increase in size and other desirable attributes are frequently associated with polyploidy and hybridisation.

MICRODISSECTION

Thanks to the investigations of Chambers and his co-workers, a very considerable amount of information is now forthcoming regarding the nature of the nucleus and cytoplasm in the living cells of animals. Unfortunately at present our information is comparatively meagre with regard to plant tissues. The principal barrier that has reacted against noteworthy advances in the microdissection of plant cells is the presence of a resistant cellulose wall. The delicate glass needle used in these investigations is unable to pierce the plant wall and becomes broken. It is thus a purely mechanical difficulty which stands in the way of any advance in this field of plant cytology.

Nevertheless, in spite of these obstacles, a start has now been made in this branch of the subject, and the more outstanding investigations will be considered here.

Cytoplasm. Searth has investigated the nature of the cytoplasm in the living cells of the mesocarp of the Snowberry, *Symphoricarpos*. It was found that the strands of cytoplasm were frequently rigidly inextensible, so that when they were slightly stretched they often broke across and recoiled back like a snapped thread. At other times the threads appeared as gushing streams. In this streaming condition, they appeared to be viscid and highly extensible and could be pulled into threads less than a micron in diameter. A needle pushed through a rapidly moving cytoplasmic strand in the staminal hairs of *Tradescantia*, for example, carried the viscid cytoplasm like a film over the point of the needle as it emerged on the opposite side of the hair. When the needle was moved backwards and forwards in the axis of a strand, the respective portions of the latter lengthened and shortened elastically, with little or no slipping of the needle. Streaming is therefore comparable, not only with high viscosity, but also with definite elasticity. Again, in *Spirogyra* the nucleus may be pushed from end to end of the cell, and it immediately recoils to its original position when released.

The question of the viscosity of cytoplasm has been a matter of controversy. It is generally recognised at the present time that protoplasm represents a complex colloidal system. Chambers and

Seifriz, using a wide variety of examples, investigated this matter of viscosity. They employed the eggs of *Fucus*, pollen tubes, and plasmodia of myxomycetes, and found the cytoplasm to be of the consistency of a liquid. There was a rapid increase in the viscosity of the eggs of *Fucus* towards the end of the ripening process, but at fertilisation there was a return to the liquid condition once more. The matter of cytoplasmic viscosity seems to be variable and to vary with different conditions of development. In the myxomycete plasmodium a sol condition was ascertained, whereas in the hyphæ of the mould *Rhizopus*, the cytoplasm was apparently in the gel state and was claimed to have the consistency of bread dough. Heilbrunn, however, has criticised the various methods that have been employed from time to time to measure the viscosity of the living cell and claimed that the microdissection method was by no means ideal for this purpose. "For the measurement of viscosity, the microdissection method can at the best give only indications of gross differences in viscosity. And even for these it is more or less uncertain." The introduction of the needle into the cell involves injury, and this might possibly alter the viscosity of the cytoplasm. The early experiments of Heilbrunn himself on the endodermal cells of *Vicia faba*, in which he observed the fall of starch grains under the influence of gravity and compared the rate with their fall in water, seemed to show that the viscosity of the cytoplasm was about eight times that of water. Later he introduced a second method, in which small iron rods were placed in the plasmodium of a myxomycete. The plasmodium was then placed under the influence of a magnetic field from an electric magnet. The extent to which the rods turned under these conditions depended on the viscosity of the cytoplasm. Here the results indicated that the viscosity was from nine to eighteen times that of water.

Weber made the claim that the form taken by some plant cells, e.g., *Spirogyra*, when plasmolysed, depends on viscosity and that the form of plasmolysis can be taken as an index of viscosity. There can be little doubt that the viscosity of the living cell varies at different times in its life. But it is important to remember that it is physical structure and not viscosity that determines whether

a system shall be a sol or gel. Hence viscosity measurements in themselves are not sufficient.

Seifriz regarded cytoplasm as being formed of either an entangled mass of fibres or as an orderly arrangement of chains of molecules; the fibrous ground substance being protein in nature. Heilbrunn has disagreed with this view, and thinks it to be a suspensoid in nature.

Chloroplast. The nature of the chloroplast in *Spirogyra* has been investigated by Scarth with microdissection methods. According to this investigator it is usually an elastic jelly of doughy consistency. When pushed about or stretched with the needle it preserves its irregularity of outline and sometimes breaks across. It is sufficiently plastic to be pushed through an opening narrower than its own diameter.

Nucleus. Chambers has described the metazoan nucleus as being fluid in nature and showing no visible structure, with the exception of one or more nucleoli and the nuclear membrane. It is quite otherwise with the nuclei of plants. They range from apparent homogeneity (*Symphoricarpus* and *Spirogyra*) through fine-grained heterogeneity (*Elodea*) to a coarsely mottled appearance (*Tradescantia*). When the cytoplasm is stripped from the nucleus of *Spirogyra* it takes the form of a smooth, transparent sphere. If it be punctured, the contents are ejected violently. The liquid portion is quickly dispersed and the solid portion then becomes visible. In *Tradescantia* the solid portion, when extruded, shows an irregular folded mass corresponding to the more highly refractive portion of the normal nucleus. This gelatinous portion is sufficiently plastic to be deformed as it passes through an opening and it sets to a tough elastic jelly outside. In *Elodea* the fine-grained nucleus ejects its contents as small irregular lumps of jelly. In *Symphoricarpus*, although the nucleus appears to be homogeneous, on ejection, the contents show as a small portion or flock of coagulum. The nuclear membrane disappears immediately the nucleus is injured.

There is a conflict of evidence with regard to the origin of the nuclear membrane. It has been considered by some as being of cytoplasmic origin. According to Scarth two membranes are

concerned. In the first place there is the inner face of the cytoplasmic envelope surrounding the nucleus and secondly the outer surface of the nucleus. Between the two there is apparently a clear solution. Thus the nuclear membrane is partly cytoplasmic and partly nuclear in origin. It may be due to this fact that there has always been a certain conflict of evidence on the matter.

Chromosomes. The nature of chromosomes in living material has been investigated by Chambers and Sands in the pollen mother-cells of *Tradescantia virginica*. The chromosomes in this species are particularly conspicuous structures, and therefore very suitable for work of this nature. The spindle area here forms a hyaline jelly-like mass, less solid than the surrounding cytoplasm and distinctly separated from it. In the living state no evidence could be found for the presence of fibres. The chromosomes lie in this jelly-like mass. They were found to be elastic, jelly-like, nodulated cylinders, which possess a cortex differing markedly in refractive index from the central core. They were also found to be very much more resistant to injury than animal chromosomes.

Meiosis. Chodat has observed the course of meiosis in the living cells of the orchid, *Gymnadenia conopsea*. In the megasporocyte, which is only surrounded by a single layer of transparent nucellar cells, the nucleus is seen to show a reticulate structure under oblique illumination. Chodat was able to follow the formation of the leptotene and pachytene threads and the production of gemini. At metaphase the eight gemini became arranged on the equator of the hyaline achromatic figure, and their disjunction and passage to the poles was also observed. In general behaviour the process was apparently very similar to that in fixed material.

THE MICROSCOPY OF THE CELL WALL

The meristematic cells of plant tissues and parenchymatous cells possess walls composed mainly of cellulose. The apical meristems of shoot and root frequently do not give the ordinary microchemical reactions for cellulose. According to Tupper-Carey and Priestley, who have investigated the apical cells of the radicle and plumule of *Vicia faba* with microchemical reagents, these cells do not give the tests for cellulose unless they have been

previously treated with strong acid or alkali. Etiolated stems require a short treatment with aqueous alcoholic potash before the normal colour reactions are given, whereas the normal green stem gives a blue colour with iodine and sulphuric acid without any such preliminary treatment, and only a short treatment is required before the reaction is given with chloridide of zinc. The claim is put forward that the reaction in the apical region is masked by the presence of other substances, *e.g.*, proteins, and the presence of these bodies prevents the reaction with iodine and sulphuric acid. Wood, however, has been unable to confirm this statement. She used the chloramine reaction which depends on setting iodine free from potassium iodide after a preliminary treatment of the tissue with chlorine gas. Various plant tissues, both monocotyledons and dicotyledons, were submitted to this

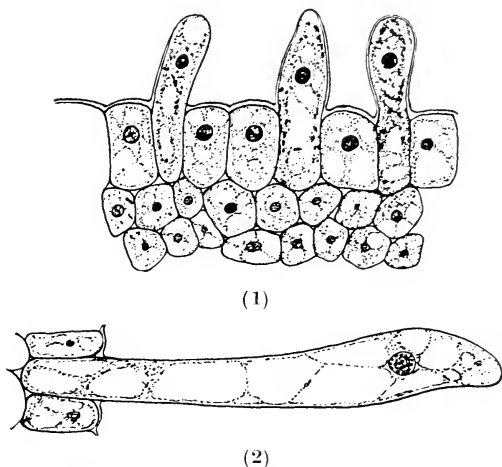

FIG. 81.—(1) Development of cotton hair from seed coat. One day after opening of flower. (2) The same, three days later. (From Denham, *Shirley Inst. Mem.*)

treatment, and in no case did the experiments indicate more than 0.001 per cent. of protein in the cellulose walls. It is therefore unlikely that their presence in the wall will interfere with the normal reactions for cellulose and pectin. According to Wood, the chemical state of the cell wall partakes of an equilibrium between cellulose proper, oxycellulose and hydrocellulose, and in most cases the two former predominate.

The Cotton Hair. The economic importance of the cotton hair has led to extended observations on its morphological nature. According to Balls, the ordinary epidermal cell of the outer ovule

coat has a thick basal wall, which separates it from the sub-epidermal layer. The side walls are thinner, and a thin cuticle covers the outer wall and dips slightly between the side walls. A nucleus, about one-fifth of the cell in length, is also present, and small vacuoles are to be found in the cytoplasm. The outer wall of the cell bulges and the nucleus moves forward towards the tip. The swelling of the outer wall increases to about twice the diameter of the original cell, and the nucleus now stains deeply and shows a well-marked nucleolus. The nucleus keeps close behind the tip of the swelling or hair, which continues to elongate at the rate of about 1 mm. per day. It would appear that in Egyptian cotton this elongation is not continuous, but is intermittent during sunshine. At a later stage, the nucleus seems to settle near the centre of the fibre, and the cell wall remains extremely thin for the first three weeks, and the cuticle covering it can scarcely be distinguished unless the wall has first received a preliminary treatment with Schweitzer's reagent.

The particular features of the hair which require special consideration are: (1) General conformation, (2) primary wall, (3) secondary thickening, (4) central canal, (5) pits in the hair wall, (6) spiral markings and striations, (7) convolutions, and (8) abnormalities.

Like the epidermal cells of most plants which have their outer wall differentiated into cuticle, the cotton hair is also cuticularised on its outer surface. The cuticle proper in normal untreated hairs is indistinguishable from the primary wall which is laid down during the process of growth in length. The chemical nature of cutin is still unknown, but it appears to be of a fatty or waxy nature. The primary wall is composed of cellulose, and is chemically distinct from that of the secondary deposition. According to Balls, "secondary thickening" in the hairs takes place by the laying down of concentric layers of cellulose, probably delimited from night to night, on the delicate cellulose-cuticle wall until a definite thickness is reached. By means of swelling reagents (9 per cent. NaOH, followed by carbon disulphide), Balls was able to prove the presence of such rings up to the number of 25, with

an average thickness of 0.4μ each, corresponding with the number of days from the cessation of growth in length.

In the dead and dried condition the lumen of the cotton hair contains the remains of the cytoplasm and nucleus responsible for its growth when alive. The whole of the lumen is covered with a layer of cytoplasm, whilst the centre is occupied by vacuoles containing cell sap, the osmotic pressure of which keeps the wall turgid. One of the points of greatest controversy in regard to the structure of the cotton hair is the presence of so-called pits. Balls described oblique slit-like cracks in the secondary thickening, tapering from the centre of the hair to the outside, and he claimed that they were responsible for the convolutions of the hair.



FIG. 82.—Normal cotton hair, showing convolutions and thickened edge.
(From Denham, *Shirley Inst. Mem.*)

Denham considered that they were due to a double line of weakness recurring in two or more super-imposed layers.

A number of different writers have described the presence of spirals and striations on the cell wall of the hair. This aspect of the morphology of the cotton hair has been widely studied by Denham, who claimed that the spirals and striations could be interpreted from the behaviour of the cytoplasm in the hairs of *Tradescantia*. Here the striations directly follow the movement of the cytoplasm, and particles can be seen moving along adjacent striations in parallel and opposite directions. There is therefore no reason for giving up the view that these striations are due to a localised spiral thickening which reaches its highest expression in the structure of tracheids and vessels. For a very full discussion, the original paper by Denham should be consulted.

The convolutions of the hair have also been investigated by Denham at the Shirley Institute. These may be divided into four classes: normal, movable, preformed and suppressed. Their presence exercises a marked influence on the spinning properties of the hair. The normal and movable convolutions are due to the

spiral inequalities of the hair. These two types tend to merge into one another, but are differentiated by their behaviour in the presence of moisture. If a single hair be placed under the microscope without a cover-slip and be gently breathed upon, a number of convolutions can be seen to run up and down the length of the hair under the influence of increased humidity. The normal or fixed convolutions, on the other hand, are altered but slightly by this treatment.

The development of the cotton hair takes place in a closed boll, and on this account the space for its development is small compared with the length to which the hair can grow. Consequently the hair is compelled to double back upon itself many times with the formation of a number of bends, and these bends are fixed in the hair structure by the ensuing "secondary thickening" of the wall. Suppressed convolutions are apparently due to spiral lines of weakness. They have also been produced in hairs after prolonged soaking in water followed by excessive twisting.

For other points in connection with the microscopy of the cotton hair the paper by Denham should be consulted, where the presence of slip planes, formation of wall layers and other factors are very fully discussed.

THE STRUCTURE AND FORMATION OF LIGNIFIED TISSUES

The early incidence of lignified tissues in the plant body is intimately involved with the chemical processes taking place in the meristematic region of shoot and root. The growing points, *i.e.*, the regions in which the formation of new tissues is taking place, lie at the extreme ends of the branches of both shoot and root. In every branch the basal region is the oldest and the apex the youngest portion, and it is within the apical region that early lignification occurs.

In longitudinal section passing through the middle portion of a growing point, as is well known, the end of the stem shows a nearly flat or dome-shaped structure, and the leaves can be seen to arise as slight projections on either side. In the apical region of the shoot three regions can be distinguished—dermatogen,

which gives rise to the epidermal layer, periblem, which produces the cortical tissue, and plerome, from which is formed the vascular system. In the leaf, the vascular system and mesophyll are formed from periblem. The root, in addition to dermatogen, periblem and plerome, possesses another layer, the calyptrogen, which forms the root cap.

In certain cases it is a well-known fact that the bast or phloem also becomes lignified, and in many plants the so-called "hard" and "soft" bast can be readily distinguished by means of aniline chloride. The formation of the bast fibres in *Baehmeria nivea* has been investigated by Aldaba. The bast fibres in this plant are particularly long, and estimations of their length have been variously given as being from 150 to 580 μ . But even the higher value given here does not express their true length, according to Aldaba, who, using a special technique of maceration with 5 per cent. potash, found that the fibres were even longer than 580 μ .

The fibres originate in a layer of undifferentiated parenchymatous elements a short distance behind the growing point. These cells are approximately 20 μ in length. Growth and differentiation now takes place simultaneously. The young, actively-growing undifferentiated fibre portions are invested solely in a hyaline, tenuous membrane, while their lower portions are provided with conspicuous thickened walls. The delicate membrane which covers the upper undifferentiated region of the fibre is a direct continuation of the outermost lamella of the thick wall which invests the older part of the fibre (Fig. 83, 1). Later, two membranes are found to be present, an inner layer, which jackets the protoplast and terminates at the lower level of the cell, and a second membrane, which covers the elongating portion of the protoplast. With elongation of the fibre, both these membranes become extended apically. Fig. 83, 5 shows the terminal portion of the fibre, which has nearly attained its maximum length. In this older and more highly differentiated cell, there are a series of inner tenuous, hyaline membranes, which are growing upwards towards the growing tip of the fibre. Each of them is in direct continuity with one of the lamellæ of the cell wall, which may be traced down-

ward into the heavily-thickened basal portion of the fibre. This would seem to suggest that as the membranes grow upward their lower extensions gradually become transformed into cell-wall lamellæ.

In the more highly differentiated portions of the fibre, there are in addition to the lamellæ, which extend upward into the elongating tip of the cell, a series of concentric layers (Fig. 83, 4), which form more or less elongated compartments. The upper and lower extremities of these compartments, which appear as semi-circular walls occluding the lumen, are referred to by different authors as "caps." The innermost of these unmodified lamellæ is an unmodified membrane. This is in marked contrast to the condition exhibited in the younger portion of the fibre, in which the upper extremity of the compartment terminates in a series of tenuous hyaline membranes, which are in direct continuity with the lamellæ in the lower portion of the compartment. Such facts as these suggest that whereas the outer cell wall lamellæ are differentiated from delicate membranes which grow upward from base to apex of the fibre, the lamellæ of the included compartments are produced by membranes of considerably restricted longitudinal growth. There is direct continuity of protoplasm through the caps, which are perforated by a terminal pore, and the terminal portions of the unmodified membranes in the upper portion of the fibre have apertures, so that there is complete continuity of the protoplasm from one end of the fibre to the other.

A detailed study of the fibres at different stages of enlargement and differentiation shows that each of the successive hyaline membranes arises from a previously-formed one. The new membrane arises as an ingrowth from the basal portion of the primary membrane and grows upward towards the elongating tip of the young fibre. After the secondary membrane has attained a considerable longitudinal extension, a tertiary membrane now arises from its basal portion, and as this membrane becomes vertically extended, a quaternary membrane arises in its turn from the basal portion (Fig. 83, 3). During the later stages of the elongation of the fibre, the successively-formed membranes grow upward towards the apex of the cell, and as they do so, their basal extensions

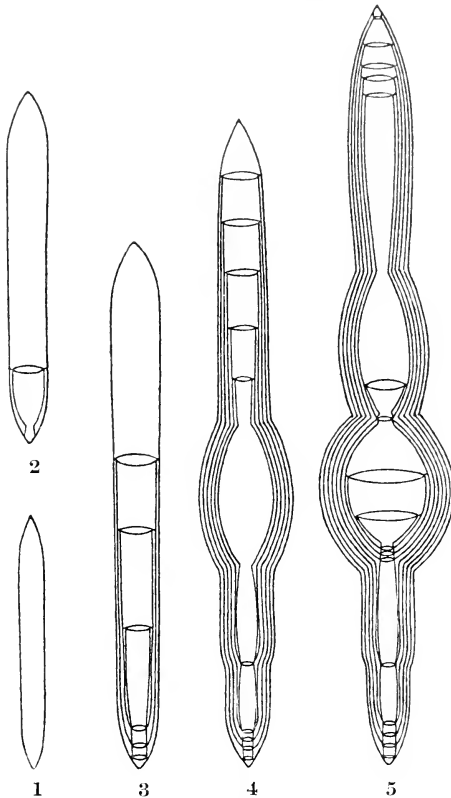

FIG. 83.—Diagrams representing various stages in the differentiation of bast fibre in *Boehmeria nivea*. (1) Young fibre enclosed by single, closed, tenuous hyaline membrane. (2) Later stage in enlargement of fibre and shows an inner secondary hyaline membrane which originates as an ingrowth of basal portion of primary membrane and grows upward towards the elongating apical portion. (3) Still later stage, showing a number of inner telescoping open tubular membranes, each of which has originated as an ingrowth from the preceding one. (4) More advanced stage of fibre development. (5) Nearly mature fibre. The fibre has practically ceased longitudinal growth and the upper extremity of the first tubular membrane has reached the upper end of the fibre. The walls of the compartments are forming and several successively formed tubular membranes are growing upward within the dilated portions of the fibre. (After Aldaba, *Amer. J. Bot.*)

become transformed into cell-wall lamellæ. Cell-wall formation may therefore be visualised as a telescoping of a series of succes-

sively-formed tubular membranes within an elongating closed tubular membrane.

The bast fibres of *Linum usitatissimum* were also investigated by the same method. Although less extensive in length than those of *Bæhmeria*, the mode of formation was found to be very similar. The first-formed basal telescoping membranes originate in the basal extremity of the cell and grow upward, ultimately reaching the apical end of the fibre.

The phenomenon of cell wall formation in bast fibres of both *Bæhmeria* and *Linum* obviously cannot be accounted for solely on the basis of the theories of apposition and intussusception. The growth of successive telescoping tenuous membranes, which subsequently differentiate into cell wall lamellæ, is more suggestive of transformation. The phenomenon of growth and differentiation in the bast fibres of these plants raises the question of whether the mode of formation of cellulose walls is fundamentally similar in all types of plant cells. In other words, is the cell wall formed in all cases by the continued growth and transformation of the plasma-membrane? It should be noted in this connection that it is not essential to assume that the successively-formed portions of the plasma-membrane arise invariably by a telescoping process, since the latter phenomenon may be a specialised one, only characteristic of certain types of elongated cells.

The statements regarding the nature of flax fibre are very conflicting, and the whole subject of the chemistry and formation of these fibres has recently been reinvestigated by Anderson. The work was mainly carried out with fresh sections, cut freehand from the plant, and microchemical tests were applied for the identification of the cell wall material *in situ*.

An important method of studying the fundamental structure of the cell wall was also worked out. The flax fibre was placed on a slide in a 1 per cent. solution of iodine in potassium iodide and 50 per cent. sulphuric acid slowly added at the side of the cover-slip. Marked swelling of the cellulose wall of the fibre now occurred. When the fibre reached the swollen condition, the cover-slip was pressed down immediately over the fibre with a needle, and considerable enlargement of the fibre took place, thus

revealing the fundamental structure. If further pressure were carefully applied, splitting of the fibres was brought about, and by careful manipulation the material could be laid flat on the slide. Additional hydrolysis and continued pressure made it possible to peel apart the different layers of the structure, and a study could then be made of their structure under higher magnification than in the case of untreated fibre.

Cells that are to differentiate into fibres are developed in the apical meristem. They lie just within the endodermis, and are distinguished soon after the primary xylem elements have been formed. The middle lamella between the young cells is composed of pectose. The secondary wall, *i.e.*, additions to the primary wall during the period of active enlargement of the cell, consists of cellulose containing pectose in varying amounts, especially near the middle lamella. The walls of the young fibre are seen in cross section to be slightly wrinkled and rather irregular.

The enlargement phase of fibre development involves two types of increase, an early rapid and extensive increase in diameter and length, and a slow but perceptible increase in diameter which is limited to certain cells and which continues throughout the life of the plant.

The first evidence of tertiary wall formation appears in the lower part of the fibre, at the close of the rapid period of elongation. This is not due to any gradual and uniform thickening of the secondary wall, but is the result of the periodic addition of new layers of material. Each successive layer of material is secreted from the protoplast, and appears in cross-section much infolded and wrinkled. It is in contact with the secondary wall at only a few points, or even not at all. The cellulose when first deposited is highly hydrated, and seems almost gelatinous. The material of the infolded deposit is pure cellulose. The first tertiary layer is pushed to the secondary wall, where it fits closely.

It does not adhere to the secondary wall, nor is any cementing material present between them. When pressed against the secondary wall by cell turgor it loses its infolded and wrinkled appearance and becomes firmer and more rigid. After the first infolded layer has been pushed against the secondary wall, other

layers are subsequently added, in the same manner, on the inside of those already present. These layers of tertiary deposition are not cemented together, nor is there any attachment between them.

There are two phases of tertiary deposition that have to be considered: a division of all tertiary deposits into from two to five distinct layers and the appearance in these larger divisions of many minute lamellæ.

The mature fibres when separated from the stem have many marked characteristics. A definite banding is particularly evident on staining with iodine and dilute sulphuric acid, as well as the presence of local displacements or nodes of local enlargement, and minute spiral striations are also present as well as isolated proto-plasts surrounded by definite cell walls in the centre of mature fibres. The presence of bands of material surrounding the fibre can be seen by swelling the fibre rapidly with strong sulphuric acid. With this treatment, the swelling is limited to certain places by the presence of these constricting bands and the swollen fibre has the appearance of a chain of tiny sausages. These bands are the remnants of the secondary wall that still adhere after retting of the fibre.

The minute spiral striations that can be made out on the surface of the fibre are fibrils which build up the fibre wall. These are arranged as aggregates of anisotropic fibrils in distinct layers, which are spirally wound alternately right and left in the separate layers. The separate fibrils show a high bi-refringence and parallel extinction under crossed nicols and retain their parallel extinction when rotated about an axis parallel to their elongation, indicating that they are homogeneous units. Pectic compounds under crossed nicols reveal their colloidal nature very sharply, and can therefore be readily distinguished from the adjacent cellulose, so that this method of using polarised light offers a ready means of determining the extent of pectic material in the cell wall.

Lignification of the flax fibre begins in the middle lamella by the conversion of pectose already present in that position. The lignification continues into the secondary wall first by the transformation of pectic material in that region, and finally the whole

of the secondary wall is affected. Microchemical tests apparently indicated that the cellulose in some way becomes modified before the onset of lignification. Lignification is not general in all the fibres in the cross-section of a stem, but occurs somewhat spasmodically in isolated groups and individuals. At no time is lignification uniform along the length of a fibre, and it increases in amount with age and as the stem matures.

The process of retting was also studied, and the fibres were submitted to the same treatment as in commerce. Retting is primarily due to bacterial decomposition taking place under water. The flax plants are allowed to remain under water till the bark strips away from the central core. After retting the plants are dried and then passed between fluted rollers to break the central woody core. This broken core is separated from the fibres by beating, and finally other impurities are removed by combing.

The first action of the bacteria is to attack the outer fibres of the stem. The secondary wall is completely decomposed, leaving the tertiary deposits exposed. The degree of lignification of the fibre influences retting to a marked degree. If the fibres be heavily lignified they are not so easily decomposed as less lignified tissues, and two critical points in the production of commercial fibre are, firstly, determination of the time of "pulling" the plants, so that extensive lignification has not taken place, and secondly the determination of the degree of retting, so that the secondary wall has been completely decomposed and destroyed.

REFERENCES

1. ACTON. *Annals Bot.*, **28**, 433, 1914.
2. ALDABA. *Amer. J. Bot.*, **14**, 16, 1927.
3. ALLEN. *Proc. Amer. Phil. Soc.*, **58**, 289, 1919.
4. ANDERSON. *Amer. J. Bot.*, **187**, **14**, 1927.
5. BAGCHEE. *Annals Bot.*, **39**, 217, 1925.
6. BLACKBURN. *Brit. J. Exp. Biol.*, **1**, 413, 1924 ; *Amer. Nat.*, **59**, 200, 1925.
7. BLACKBURN and HARRISON. *Annals Bot.*, **35**, 159, 1921 ; **38**, 361, 1924. *Brit. J. Exp. Biol.*, **1**, 557, 1924.
8. BOLLES LEE. *Quart. J. Micr. Sci.*, **69**, 1, 1924.
9. BOWEN. *Zeit. Zell. Mik. Anat.*, **6**, 689, 1928 ; **9**, 1, 1929. *Annals Bot.*, **43**, 309, 1929.
10. CARTER. *Annals Bot.*, **41**, 139, 1927.
11. CASTETTER. *Amer. J. Bot.*, **12**, 270, 1925.

12. CHAMBERS and SANDS. *J. Gen. Physiol.*, **5**, 815, 1923.
13. CLELAND. *Bot. Gaz.*, **77**, 149, 1924.
14. COOK. *Anns. Bot.*, **42**, 347, 1928.
15. CHODAT. *Bull. Soc. Bot. Genève*, 1925.
16. DANGEARD. *Recherche sur l'appareil vacuolaire*. Thesis., Paris, 1923.
17. DENHAM. *Shirley Inst. Mem.*, **1**, 87, 1922; **2**, 63, 1923.
18. DEVISÉ. *La Cellule*, **32**, 249, 1922.
19. FARR. *Amer. J. Bot.*, **9**, 296, 1922.
20. GATES. *La Cellule*, **35**, 49, 1925; *Nature*, Dec. 21, 1929.
21. GATES and LATTER. *J. Roy. Micr. Soc.*, 209, 1927.
22. GATES and REES. *Anns. Bot.*, **35**, 365, 1921.
23. GATES and SHEFFIELD. *Phil. Trans. Roy. Soc. (Lond.)*, **217B**, 367, 1929; *Proc. Roy. Soc. (Lond.)*, **105B**, 499, 1929.
24. GREGOR and SANSOME. *J. Gen.*, **22**, 373, 1930.
25. GUILLIERMOND. *Amer. J. Bot.*, **16**, 1, 1929.
26. HAUPT. *Bot. Gaz.*, **75**, 170, 1923.
27. HORNUNG and PETRIE. *Proc. Roy. Soc. (Lond.)*, **102B**, 188, 1927.
28. HORNE. *Anns. Bot.*, **44**, 199, 1930.
29. JØRGENSEN. *J. Gen.*, **18**, 63, 1927.
30. KAUFMANN. *Amer. J. Bot.*, **13**, 59, 1926.
31. KIHARA and ONO. *Bot. Mag.*, Tokyo, **37**, 84, 1923.
32. LATTER. *Anns Bot.*, **40**, 277, 1926.
33. DE LITARDIÈRE. *La Cellule*, **31**, 255, 1921.
34. MARTENS. *La Cellule*, **32**, 333, 1922; *C. R. Acad. Sci.*, Paris, **179**, 1280, 1924; *La Cellule*, **36**, 125, 1925.
35. MARSTON. *Biochem. J.*, **17**, 851, 1923.
36. MEURMAN. *Soc. Sci. Fennica Comm. Biol.*, **2**, No. 3, 1925.
37. PATTEN, SCOTT and GATENBY. *Quat. J. Micr. Sci.*, **72**, 387, 1929.
38. REEVES. *Amer. J. Bot.*, **15**, 114, 1928.
39. ROBYNS. *La Cellule*, **34**, 367, 1924; **37**, 145, 1926; **38**, 176, 1927.
40. SANDS. *Amer. J. Bot.*, **10**, 343, 1923.
41. SANTOS. *Bot. Gaz.*, **75**, 42, 1923; **77**, 353, 1924.
42. SCARTH. *Protoplasma*, **2**, 189, 1927.
43. SCOTT. *Amer. J. Bot.*, **16**, 598, 1929.
44. SHARP. *Bot. Gaz.*, **88**, 349, 1929.
45. SHEFFIELD. *Anns. Bot.*, **41**, 779, 1927; *Proc. Roy. Soc. (Lond.)*, **105B**, 207, 1929.
46. STOUGHTON. *Proc. Roy. Soc. (Lond.)*, **105B**, 469, 1929.
47. TANDY. *Anns. Bot.*, **41**, 321, 1927.
48. TUPPER-CAREY and PRIESTLEY. *Proc. Roy. Soc. (Lond.)*, **95B**, 128, 1923.
49. VAN CAMP. *La Cellule*, **34**, 7, 1924.
50. WEBER. *Ber. deut. bot. Ges.*, **40**, 212, 1922. *Arch. f. Ges. Physiol.*, **198**, 644, 1923.
51. WINGE. *C. R. Trav. Lab. Carlsberg*, **14**, 18, 1923.
52. WOOD. *Anns. Bot.*, **40**, 547, 1926.
53. ZIRKLE. *Bot. Gaz.*, **86**, 402, 1928.

INDEX

- Abaxas grossularita*, position of vacuoles in, 104
- Achromatic** figure in plants, 197
- Acroblast**, 109
formation of, 141, 142
- Acrosomal** granule, 110
- Acrosome**, 140 *et seq.*
formation of, 109, 110
types of, 109
- Adrenals**, cholesterol metabolism and, 27
histology of, 27
sexual function and, 27
- Allopolyploids**, 224
- Amaba*, distribution of mitochondria in, 126
- Aneuploids**, 228
- Animal** cells, function of Golgi apparatus in, summary of, 119-121
- Aqueous** fluid, particles in, slit-lamp appearances of, 80
- Archiplasts**, 170
- Archoplasm**, 91, 96
in yolk formation, 120, 145
- Auriculo-ventricular** node, 30
- Autopolyploids**, 224
- Bacteria**, nucleus in, problem of, 194
- Biomicroscopy**, 72
- Blood**, granular leucocytes in, 15
histology of, 13
macrophages in, 18
monocytes in, 22
myeloblasts in, 14
plasma cells in, 13
platelets, origin of, 16, 17
Türk cells in, 14
- Bahmeria nirea*, bast fibres in, formation of, 247-249
- Brachymeiosis**, 216
- Cancer**, cytology of, 161
- Cardiac** muscle, 28
bundle of His, 29
- Cataract**, 83, 84
- Caria*, spermatogenesis in, 130, 142, 143, 144
- Cell**, constituents of, 90
inclusions, protoplasmic and deutoplasmic, 91
membranes, 159
organs, 3
wall, microscopy of, 242
- Cells**, various, illustrating nucleolar extrusion, 136, 137
- Central** apparatus in protoplasmic inclusions, 91
- Centrosome** and Golgi apparatus, topographical relationship of, 5
- Centrioles**, 91
- Chloroplast**, investigation by microdissection, 241
- Cholesterol** metabolism, adrenals and, 27
- Chondriome**, 98
in plants, 99
- Chromaffin** cells in intestine, 10
- Chromidia**, 91
and yolk nuclei, relationship between, 145
- Chromonema** hypothesis, 178
- Chromophobe** cells of pituitary, 23
- Chromosomal** chimeras, 228
material, 90
- Chromosomes**, deletions in, 135
in plants, size relations between, 225
structure of, 177
investigation by microdissection, 242
plant and animal, differences between, 180
translocation of, 133, 134
- Ciliary** body, inflammation of, 32
- Ciliates**, contractile vacuoles in, 158
- Ciona intestinalis*, mitochondria in, 132
oocytes of, Golgi elements in, 94
yolk formation in, 121, 152, 153
- Clivia*, root meristem of, nucleolus, 183
- Columbella*, granular acrosome in, 110
- Conjunctiva**, bulbar, pigmented mole of, slit-lamp appearance of, 73
slit-lamp examination of, 73

- Cornea**, abnormalities on or of, detection by sclerotic scatter, 62, 63
 endothelial face of, observation of, 57, 58, 59
 illumination of, methods of, 36-39, 45-64
 nebula of, optical appearances of, 51, 76
 slit-lamp appearance of, 75, 76
 normal, slit-lamp appearances of, 49, 74
 optical section of, scintillating sheen in, 61, 62
 pathological processes in, determination of level of, 32, 49, 67
 perforation of, 77
 precipitates on, 32, 37, 38, 49, 78
 scar on face of, slit-lamp appearances of, 76, 77
 slit-lamp examination of, 49-51, 57-61, 74-78
 surfaces of, observation by direct illumination with specular reflection, 53, 55, 58
 vacuoles in, retroillumination of, 65
- Cotton hair**, convolutions and thickened edge of, 244, 245
 development of, 246
 morphology of, 243
- Cyanophyceæ**, nuclear division in, 192
- Cytokinesis** in plants, 199
- Cytology** of cancer, 161
 pathological, 160
 present trend of, 88-89
- Cytoplasm**, 90
 investigation by microdissection, 239
 viscosity of, 239
- Cytosome**, 90
- Czapski binocular microscope**, 44, 45, 72
- Deletions** in chromosomes, 135
- Dentoplasmic cell-inclusions**, 91
- Diabetes**, changes in islets of Langerhans in, 12, 13
- Diaphragm-lamp**, the, 39
- Dictyosomes**, 91, 101, 107
- Digestion**, enzymes for process of, relation of mitochondria to, 127
- Diplodinium ecaudatum*, neuromotor apparatus in, 155, 156
- Drosophila**, chromosome figures from, showing translocation, 133, 134, 135
- Elodea canadensis*, microsporogenesis in, 220
- Endothelial cells**, 19
- Enzymes** for process of digestion, relation of mitochondria to, 127
- Equistum arvense*, plastidome system in, 170
- Euplotes*, neuromotor apparatus in, 156
- Eye**, microscopy of, 31
- Eyelids**, slit-lamp examination of, 73
- Farella*, neuromotor system in, 155
- Fincham's pattern** of slit-lamp, 45, 47
- Flagellates**, contractile vacuoles in, 158
- Focusing** lenses, influence of, on configuration of focused slit-beam, 43, 44
- Formation** of acrosomes, 141, 142
- Formica rufa*, nucleolar emission in, 136, 152
- Fruits**, cultivated, sterility and polyploidy in, 236
- Gastric glands**, cells of, functions of, 8
 types of cells in, 8
 mucosal cells, mitochondria of, 8
See also Stomach.
- Germ-cells**, female, function of Golgi apparatus in, 120, 147 *et seq.*
- Golgi apparatus**, 3, 91
 and centrosome, topographical relationship of, 5
 as an artefact, 107
 cells of gastric glands, 9
 chemical nature of, 96
 form and structure of, 92 *et seq.*
 function of, 109 *et seq.*
 summary of, 119, 121
 in female germ-cells, function of, 120
 in intestinal epithelium, rôle of, 119
 in intestine, 10
 in kidneys, 119
 in lachrymal and salivary glands, 112-114
 in megakaryocytes, 17
 in neurones of *Helix aspersa*, 117
 in parathyroids, 25
 in plants, 168
 position of, 171
 in Protozoa, 157
 in spermatid, 109
 in spermatogenesis, 95
 in thyroid glands, 25, 118
 in *vicia faba*, 170
 in yolk formation, 120, 147 *et seq.*
 male, reproductive system in, 114

- Golgi apparatus**, morphology of, summary of, 108
 one-directional functional activities of, 96
 position of, relationship to function of cell, 4
 relation of, to contractile vacuoles in Protozoa, 114, 115
 to secretory granules, 111 *et seq.*
 to trophospongium, 5
 to vacuome, 104, 105
 structure of, 4
 invertebrates, 93
 vertebrates, 93
 visibility in living cell, 97
 vital staining in relation to, 97
 remnant, 142
- Gonioscope**, Troncoso's, 34
- Graminæ**, polyploidy in, 229
- Granular leucocytes**, 15
- Granule**, acrosomal, 110
- Gullstrand slit-lamp**, 39-42
- Haploids**, 227
- Hassall's corpuscles** in thymus, 26
- Heidenhain**, telophragma of, 29
- Helix aspersa*, neurones of, Golgi apparatus in, 117
 position of vacuoles in, 105
 spermatogenesis of, "Nebenkern" in, 101
 spermatogenesis in, 130
- "Heller Hof," 91
- Hemiptera**, spermatogenesis in, 130, 142
- Heterophytic plants**, 218
- Heterothallic plants**, 218
- His**, bundle of, 29
- Histiocytes**, 18
- Histiocytic system**, cells of, changes in, 21
 tissue, focal hypertrophy of, 21
- Hodgkin's disease**, changes in reticulo-endothelial system in, 19, 20
- Holmgren's trophospongium**, 92, 95, 99
- Homothallic plants**, 218
- Humulus*, sex-chromosomes in, 222
- Hymenoptera**, nucleolar emission in, 136
- Idioplasm**, 96
- Idiosome**, 91
- Illumination**, direct, and retroillumination, simultaneous comparison for localisation of depth, 71
 in slit-lamp examination, 47, 48, 63
- Illumination**, methods of, 63
 proximal, 62, 63
 with slit-lamp, methods of, 63
- Inclusions of cells**, 91
- Intestinal epithelium**, rôle of Golgi apparatus in, 119
 glands, patches of, in stomach, 9
- Intestine**, basal or argentaffin cells of, 10
 chromaffin cells in, 10
 histology of, 10
- Iris**, inflammation of, 32, 80
 malignant growth of, 81
 slit-lamp examination of, 81
- Janus red**, staining of mitochondria with, 125
- Karyosome**, 90
- Keratic precipitates**, 32, 37, 38, 49, 78
 slit-lamp appearances of, 48, 49, 78
- Keratization** in skin, 6
 process of, 7
 "Keratitis profunda," 32
- Kidneys**, Golgi apparatus in, 119
- Kinochromatin**, 184
- Kupffer cells**, 11, 21
- Lachrymal glands**, Golgi apparatus in, 114
- Langerhans**, islets of, 12
 changes in, in diabetes, 12, 13
 types of granules in cells of, 12
- Lathraea*, cytokinesis in, 201
 meiosis in, 213
- Lathyrus odoratus*, nucleolus of, 184, 185
- Lens capsule**, shagreen appearance of, 82, 83
 concussion injury to, 84
 cortex, specular lustre in, 61, 62
 vacuoles in, retroillumination of, 65, 66
 crystalline, capsule of, in axis of specular reflection, 56, 57, 82
 concussion injury of, slit-lamp appearances in, 84
 direct illumination of, 52
 fibres of, 32
 layers of, age of, 32, 52, 85
 minute changes in, slit-lamp examination for, 82-84
 pathological conditions of, exact localisation of, 33
 slit-lamp examination of, 81
 suture lines in, 33
 zones of, 52

- Lepidoptera**, spermatogenesis in, 130, 142, 143, 144
- Lepidosome** of mitochondria, 101
- Lepisma*, acrosome in, 140
- Leucocytes**, granular, 15
- Leuco-melanin**, 7
- Libellula*, nucleolar emission in, 136, 138, 146
- Light**, diffuse reflection of, 34, 35, 36
specular reflection of, 34, 53-61
transmission with refraction, 34, 35
- Ligniera junci*, nuclear division in, 188
- Lignified** tissues, structure and formation of, 246
- Limbus**, innocent melanoma at, 73
- Limulus polyphemus*, nucleolar emission in, 138
- Linum usitatissimum*, bast fibres of, 250
- Listera ovata*, chromatic filament in, 179
- Lithobius forficatus*, nucleolar emission in, 139
- Liver**, cells of, reticulation of, 11
histology of, 11
Kupffer cells in, 21
stellate cells of Kupffer in, 11
- Lumbricus*, oogenesis of, Golgi elements in, 94
mitochondria in, 131
- Lymphocytes**, mitochondria in, 13
- Lymphocytic** plasma cells, function of, 14
- Lymphoidocytes**, 15
- Macromitosomes** in *Helix aspersa*, 101
- Macrophages**, 18
- Mayou's** pattern of slit-lamp, 45, 46
- Megakaryocyte**, origin of, 17
- Meiosis**, 203
investigation by microdissection, 242
irregularities occurring during, 208, 209
- Melandrium*, sex-chromosomes in, 222
- Melanin** in skin, origin of, 7
- Melanoblasts**, 7
- Melilotus alba*, cytokinesis in, 201
- Metachromatic** corpuscles, 175
- Metachromes**, 175
- Metamyelocyte**, 15
- Metazoa**, Golgi apparatus of, connection with secretion, 116
- Microdissection**, 239
of cell membranes, 159
value of, 90
- Micromitosomes** in *Helix aspersa*, 101
- Microscopy**, limitations of, 1, 2
- Mitochondria**, 91
arrangement of, 3
chemical nature of, 123
distinctive characteristics of, 3
distribution of, in Protozoa, 125
forms of activity of, 124
function of, 3
growth of, 124
in gastric mucosal cells, 8
in intestine, 10
in lymphocytes, 13
in megakaryocytes, 17
in monocytes, 22
in myeloblasts, 14, 15
in oogenesis and vitellogenesis, 131, 145, 146, 152, 153
in plants, 171
function of, views on, 172
migration of, 174
in Protozoa, 158
in thymus, 26
influence on starch grains, 172
lepidosome of, 101
micro-chemical reactions of, 123
morphology and function of, 123 *et seq.*
reaction of, 3
shape of, 3
staining of, 125
- Mollusca**, vitellogenesis of, 145
- Monocytes**, 22
mitochondria in, 22
- Monocystis*, mitochondria in. form and structure of, 127
- Motorium** in motor system of Protozoa, 154, 155
- Muscle**, cardiac, 28
histology of, 28
- Myeloblasts**, 14
staining of, determination of characters by, 14
- Myelocyte**, 15
- Myoid** cells of thymus, 26
- Nebenkern**, 130, 131, 142, 143
in *Helix aspersa*, 101
- Nerve** cells, Golgi apparatus in, 118
- Neutral** red staining of Golgi, 97
- Nisse** granules, 117
- Nuclear** division in plants, 188
- Nucleolar** extrusion, various cells illustrating, 136, 137, 139
- Nucleolus**, 90
extrusions of, relation to formation of yolk, 140, 146
in plants, function of, 182

- Nucleoplasm**, 90
- Nucleus** and nucleolus, 133
 investigation by microdissection, 241
 translocation and its related phenomena, 133
- Oenothera*, meiosis in, 203
gigas, polyploidy in, 224
rubricalyx, megaspore development in, 206, 207
- Oogenesis** and yolk formation, 144
 mitochondria in, 131, 145, 146, 152, 153
- Opacity** and optical density, 68, 69
- Opalina*, mitochondria in, distribution of, 125
 form and structure of, 127
- Osmiophilic platelets**, 168
 in plant cells, 102
- Paludina*, acrosome in, 142
 granular acrosome in, 110
- Pancreas**, histology of, 12
- Pannus**, slit-lamp appearances of, 75
- Paramacium*, distribution of mitochondria in, 125
 neuromotor apparatus in, 156
- Parathyroids**, histology of, 25
- Paris quadrifolia*, chromatic filament in, 179
- Patella*, nucleolar emission in, 138
 yolk formation in, 122, 145, 146, 147, 148, 152, 153, 154
- Periplaneta americana**, oogenesis of,
 Golgi elements in, 94
 nucleolar emission in, 136, 146
- Pituitary**, cellular composition of, 22
 chromophobe cells of, 23
 types of granules in, 23
- Plant cells**, osmiophilic platelets in, 102
- Plasma cells** in blood, 13
- Plasmatic microsomes**, 193
- Plasmodiophora*, nuclear phenomena in, 188, 191
- Plasmosome**, 90, 182
- Plastidome**, 169
 in plants, 99
- Platelets**, blood, origin of, 16, 17
- Polyploids**, higher, 229
- Polyploidy**, 223
 as source of species and horticultural varieties, 233
- Post-nuclear bodies**, formation and origin of, 143
- Protomitosi**s, 188
- Protoplasmic cell-inclusions**, 91
- Protozoa**, contractile vacuoles and their relation to Golgi apparatus, 114, 115
 mitochondria of, 158
 neuromotor system of, 154 *et seq.*
- Pseudochondriome**, 169
- Pseudopodia**, 16, 17
- Reflection** from polished surfaces, 53
 specular, alteration of axis of, 60
 of cornea, 56-61
- “**Relucency**,” definition of, 36
- Reticular cells**, 19
- Reticulo-endothelium**, 18
 changes in Hodgkin's disease, 19, 20
- Retroillumination**, 38, 64-69
 and direct illumination, simultaneous comparison for localisation of depth, 71
 dissimilarity of binocular images under high magnification, 70
 light for, focusing of, 68
 of vacuoles in lens-cortex and cornea, 65, 66
- Retting** of flax fibres, process of, 253
- Saccocirrus*, nucleolar emission in, 138
- Salivary glands**, Golgi apparatus in, 112
- Sclerotic scatter**, method of, 38, 63, 64, 75
 nebula of cornea as seen by, 75, 76
- Secretory cycle**, relation of Golgi apparatus to, 111 *et seq.*
- Sex-chromosomes** in heterophytic angiosperms, 221
 in plants, 218
- Sexual function**, adrenals and, 27
- Shadow streaks**, production of, 52
- Slit-lamp examination**, direct illumination in, 47, 48, 63
 Gullstrand, 39-42
 adjustment of, 43
 methods of illumination with, 63
 microscopy of eye, range of magnification in, 73
- Skin**, histology of, 6
 intra-cellular fibrils of, 6
 keratinisation in, 6
 mitochondria in, 6
 pigment in, origin of, 7
- Sorosphara*, nuclear phenomena in, 191
- Specular lustre** in lens-cortex, 62
 reflection of an incident slit-beam, 58

- Spermateleosis**, mitochondria in, 130, 141
- Spermatids**, 141
Golgi apparatus in, 109
- Spermatocyte**, mitochondria in, 129, 141
structure of, 141
- Spermatogenesis**, 140
in *Cavia*, 130, 142, 143, 144
in *Drosophila funebris*, 135
in *Helix*, 130
in Hemiptera, 130, 142
in Lepidoptera, 130, 142, 143, 144
vacuolar system in, 143
- Spermatogonium**, mitochondria in, 129
- Spermatoleosis**, 141 *et seq.*
- Spermatozoon**, formation of, 141
Spharocarpus, chromosome sets from, 219
- Sphere** or attraction sphere, 91
- Sphèrome** in plants, 99
Spongospora, nuclear division phenomena in, 191
- Stomach**, histology of, 7
patches of intestinal glands within, 9
See also Gastric.
- Strawberry**, polypoidy in, 238
Synergus, nucleolar emission in, 136, 152
- Tetraploidy**, 225
- Thymus**, Hassall's corpuscles in 26
histology of, 25, 26
myoid cells of, 26
- Thyroid**, differences in form of Golgi apparatus and mitochondria in resting and active phases, 128, 129
Golgi apparatus in, 118
histology of, 24
- Tigroid bodies**, 117
- Tissue cultivation *in vitro***, value of, 90
- Tissues** and organs, 6
- Tonoplasts**, 175
Tridacantha virginica, chromosomes of, 180
- Transillumination**, 38
- Translocation** of chromosomes, 133, 134
- Triploids**, 226
Triton, mucous cells, gastric epithelium of, 101
- Troncoso's gonioscope**, 34
- Trophospongium** of Holmgren, 92, 95, 99
relationship of Golgi system to, 5
- Türk cells** in blood, 14
- Vacuolar system** in spermatogenesis, 143
- Vacuoles**, contractile, in ciliates, 158
in flagellates, 158
relation to Golgi apparatus, in Protozoa, 114, 115
in anterior lens cortex, retroillumination of, 65
- Vacuome**, 91, 98 *et seq.*
in plant cells, 174
relation of, to Golgi apparatus, 104, 105
staining of, 99, 100
theory, 98 *et seq.*
- Vicia faba*, root tip of, Golgi apparatus in, 170
- Vitreous fluid**, fibrillar or reticulate appearance, by slit-lamp examination, 85
normal 33, 85
pathological conditions of, differential diagnosis of, 33, 85
- Vitellogenesis** in mollusca, 145
in oogenesis, 144
mitochondria in, 131, 145, 146, 152, 153
- Yolk**, albuminous or proteid, formation of, 152, 153
fatty or lipoidal, derivation of, 151 *et seq.*
formation in *Ciona intestinalis*, 121, 152, 153
in *Patella*, 122, 145, 146, 147, 148, 152, 153, 154
Golgi apparatus in, 120, 147 *et seq.*
methods of, 148
oogenesis and, 144
summary of, 148-151
nuclei and chromidia, relationship between, 145
nucleus, formation of, 131, 132
varieties of, 147
- Zea mays*, cytokinesis in, 203
- Zoology**, 88-163

