



P. 1. A. 96.

BRITISH ASSOCIATION
FOR THE ADVANCEMENT
OF SCIENCE

REPORT

OF THE

NINETY-FIFTH MEETING
(NINETY-SEVENTH YEAR)



LEEDS—1927
AUGUST 31—SEPTEMBER 7

LONDON

*OFFICE OF THE BRITISH ASSOCIATION
—BURLINGTON HOUSE, LONDON, W. 1*

1927



CONTENTS.

	PAGE
OFFICERS AND COUNCIL, 1927-28.....	v
LOCAL OFFICERS, LEEDS, 1927.....	vii
SECTIONS AND SECTIONAL OFFICERS, LEEDS, 1927.....	vii
ANNUAL MEETINGS : PLACES AND DATES, PRESIDENTS, ATTENDANCES, RECEIPTS, SUMS PAID ON ACCOUNT OF GRANTS FOR SCIENTIFIC PURPOSES (1831-1927)	x
REPORT OF THE COUNCIL TO THE GENERAL COMMITTEE (1926-27)	xiv
GENERAL MEETINGS, PUBLIC LECTURES, ETC., AT LEEDS	xviii
EXTERNAL LECTURES	xx
GENERAL TREASURER'S ACCOUNT (1926-27)	xxi
RESEARCH COMMITTEES (1927-28)	xxvi
RESOLUTIONS AND RECOMMENDATIONS (LEEDS MEETING).....	xxxii
THE PRESIDENTIAL ADDRESS :	
Darwin's Theory of Man's Descent as it stands to-day. By Prof. Sir ARTHUR KEITH, F.R.S.	1
SECTIONAL PRESIDENTS' ADDRESSES :	
A.—The Outstanding Problems of Relativity. By Prof. E. T. WHITTAKER, F.R.S.	16
B.—Co-ordination Compounds. By Dr. N. V. SIDGWICK, F.R.S. ..	27
C.—The Tertiary Plutonic Centres of Britain. By Dr. HERBERT H. THOMAS, F.R.S.	43
D.—The Ancient History of Sponges and Animals. By Dr. G. P. BIDDER	58
E.—Some Problems of Polar Geography. By Dr. R. N. RUDMOSE BROWN	75
F.—Rationalisation of Industry. By Prof. D. H. MACGREGOR ..	98

	PAGE
G.—Invention as a Link in Scientific and Economic Progress. By Prof. Sir JAMES B. HENDERSON	120
H.—The Englishman of the Future. By Prof. F. G. PARSONS	138
I.—The Development of Human Physiology. By Dr. C. G. DOUGLAS, C.M.G., F.R.S.	155
J.—Mental Unity and Mental Dissociation. By Dr. WILLIAM BROWN	167
K.—Some Aspects of the Present-day Investigation of Protophyta. By Prof. F. E. FRITSCH.....	176
L.—The Broadening of the Outlook in Education. By the DUCHESS of ATHOLL, D.B.E., M.P.	191
M.—Agriculture and National Education. By C. G. T. MORISON ..	202
REPORTS ON THE STATE OF SCIENCE, ETC.	215
SECTIONAL TRANSACTIONS	314
CONFERENCE OF DELEGATES OF CORRESPONDING SOCIETIES	419
REFERENCES TO PUBLICATIONS OF COMMUNICATIONS TO THE SECTIONS	430
INDEX.....	437

British Association for the Advancement of Science.

OFFICERS & COUNCIL, 1927-28.

PATRON.

HIS MAJESTY THE KING.

PRESIDENT.

Prof. Sir ARTHUR KEITH, M.D., LL.D., F.R.S.

PRESIDENT ELECT FOR THE GLASGOW MEETING.

Prof. Sir WILLIAM H. BRAGG, K.B.E., D.Sc., D.C.L., LL.D., F.R.S.

VICE-PRESIDENTS FOR THE LEEDS MEETING.

The Rt. Hon. the LORD MAYOR OF
LEEDS (Alderman HUGH LUPTON).

His Grace the LORD ARCHBISHOP OF
YORK (Most Rev. COSMO G. LANG,
P.C., G.C.V.O., D.D.).

The CHANCELLOR OF LEEDS UNIVERSITY
(His Grace the DUKE OF DEVONSHIRE,
K.G., P.C., G.C.M.G., G.C.V.O.).

The LORD-LIEUTENANT OF THE COUNTY
OF THE WEST RIDING OF YORKSHIRE
(Rt. Hon. the EARL OF HAREWOOD,
G.C.V.O.).

Viscount LASCELLES, K.G., D.S.O.

The LORD BISHOP OF RIPON (Rt. Rev.
E. A. BURROUGHS, D.D.).

The Rt. Hon. LORD AIREDALE.

The PRO-CHANCELLOR OF LEEDS UNI-
VERSITY (Col. C. H. TETLEY, D.S.O.,
T.D., M.A.).

The VICE-CHANCELLOR OF LEEDS UNI-
VERSITY (J. B. BAILLIE, O.B.E., M.A.,
D.Phil., LL.D.).

The CHAIRMAN OF THE LEEDS EDUCATION
COMMITTEE (Alderman LESLIE OWEN).

The CHAIRMAN OF THE WEST RIDING
EDUCATION COMMITTEE (Sir PERCY
JACKSON, LL.D.).

The Hon. Sir GERVASE BECKETT, Bart.,
M.P.

The Hon. RUPERT BECKETT.

Col. Sir E. A. BROTHEKTON, Bart., LL.D.

Sir BERKELEY MOYNIHAN, Bart.,
K.C.M.G., C.B., F.R.C.S.

Sir CHARLES WILSON, LL.D., M.P.

Sir EDWIN AIREY.

The VICAR OF LEEDS (Rev. W. THOMPSON
ELLIOTT, M.A.).

The BISHOP OF LEEDS (Rt. Rev. J. R.
COWGILL).

The PRESIDENT OF THE FREE CHURCH
COUNCIL (Rev. G. HUNT).

The CHIEF RABBI OF LEEDS (Rev. Dr. J.
ABELSON).

Alderman G. RATCLIFFE.

Alderman CHARLES LUPTON.

Alderman J. ARNOTT.

Sir ALFRED F. YARROW, Bart., F.R.S.

VICE-PRESIDENTS ELECT FOR THE GLASGOW MEETING.

The Rt. Hon. the LORD PROVOST OF
GLASGOW (Mr. DAVID MASON, O.B.E.).

His Grace the DUKE OF MONTROSE,
C.V.O., C.B.

The Rt. Hon. the EARL OF HOME.

The Rt. Hon. the EARL OF GLASGOW,
D.S.O.

The Rt. Hon. the LORD BLYTHSWOOD,
K.C.V.O., D.L.

The Rt. Hon. the LORD BELHAVEN AND
STANTON.

The Rt. Hon. the LORD INVERNAIRN.

The Rt. Hon. the LORD WEIR, LL.D.

The Rt. Hon. the LORD MACLAY, LL.D.

The Rt. Hon. Sir JOHN GILMOUR, Bart.,
D.S.O., M.P.

Sir DONALD MACALISTER, Bart., K.C.B.,
LL.D., D.L.

Sir JOHN MAXWELL STIRLING-MAXWELL,
Bart., D.L., LL.D.

Sir JAMES BELL, Bart., C.B., D.L., LL.D.

Sir D. M. STEVENSON, Bart., D.L., LL.D.

Sir ARCHIBALD MCINNES SHAW, C.B.,
D.L., LL.D.

Sir MATTHEW W. MONTGOMERY, D.L.,
LL.D.

Prof. F. O. BOWER, LL.D., D.Sc., F.R.S.

GENERAL TREASURER.

E. H. GRIFFITHS, Sc.D., D.Sc., LL.D., F.R.S.

GENERAL SECRETARIES.

Prof. J. L. MYRES, O.B.E., D.Sc., F.S.A., F.B.A.		F. E. SMITH, C.B., C.B.E., D.Sc., F.R.S.
---	--	--

SECRETARY.

O. J. R. HOWARTH, O.B.E., M.A., Burlington House, London, W. 1.

ORDINARY MEMBERS OF THE COUNCIL.

Prof. J. H. ASHWORTH, F.R.S.	Sir T. HOLLAND, K.C.S.I., F.R.S.
Rt. Hon. LORD BLEDISLOE, K.B.E.	Col. Sir H. G. LYONS, F.R.S.
Prof. A. L. BOWLEY.	Dr. C. S. MYERS, F.R.S.
Prof. E. G. COKER, F.R.S.	Prof. T. P. NUNN.
Prof. W. DALBY, F.R.S.	Prof. A. O. RANKINE.
Dr. H. H. DALE, Sec. R.S.	C. TATE REGAN, F.R.S.
E. N. FALLAIZE.	Prof. A. C. SEWARD, F.R.S.
Sir J. S. FLETT, K.B.E., F.R.S.	Dr. F. C. SHRUBSALL.
Sir HENRY FOWLER, K.B.E.	Dr. N. V. SIDGWICK, F.R.S.
Sir R. A. GREGORY.	Dr. G. C. SIMPSON, C.B., F.R.S.
C. T. HEYCOCK, F.R.S.	Prof. A. SMITHELLS, C.M.G., F.R.S.
Prof. J. P. HILL, F.R.S.	Prof. T. B. WOOD, C.B.E., F.R.S.
A. R. HINKS, C.B.E., F.R.S.	

EX-OFFICIO MEMBERS OF THE COUNCIL.

The Trustees, past Presidents of the Association, the President for the year, the President and Vice-Presidents for the ensuing Annual Meeting, past and present General Treasurers and General Secretaries, past Assistant General Secretaries, and the Local Treasurers and Local Secretaries for the Annual Meetings immediately past and ensuing.

TRUSTEES (PERMANENT).

Major P. A. MACMAHON, D.Sc., LL.D., F.R.S.		Sir ARTHUR EVANS, M.A., LL.D., F.R.S., F.S.A.
Hon. Sir CHARLES A. PARSONS, O.M., K.C.B., LL.D., D.Sc., F.R.S.		

PAST PRESIDENTS OF THE ASSOCIATION.

Rt. Hon. the EARL OF BALFOUR, O.M., F.R.S.	Hon. Sir C. A. PARSONS, O.M., K.C.B., F.R.S.
Sir E. RAY LANKESTER, K.C.B., F.R.S.	Prof. Sir C. S. SHEBBINGTON, O.M., G.B.E., F.R.S.
Sir J. J. THOMSON, O.M., F.R.S.	Sir ERNEST RUTHERFORD, O.M., Pres. R.S.
Sir E. SHARPEY-SCHAFFER, F.R.S.	Major-Gen. Sir DAVID BRUCE, K.C.B., F.R.S.
Sir OLIVER LODGE, F.R.S.	Prof. HORACE LAMB, F.R.S.
Sir ARTHUR SCHUSTER, F.R.S.	H.R.H. The PRINCE OF WALES, K.G., D.C.L., F.R.S.
Sir ARTHUR EVANS, F.R.S.	

PAST GENERAL OFFICERS OF THE ASSOCIATION.

Sir E. SHARPEY-SCHAFFER, F.R.S.		Major P. A. MACMAHON, F.R.S.
Dr. D. H. SCOTT, F.R.S.		Prof. H. H. TURNER, F.R.S.
Dr. J. G. GARSON.		

HON. AUDITORS.

Prof. A. BOWLEY.		Prof. A. W. KIRKALDY.
------------------	--	-----------------------

LOCAL OFFICERS FOR THE LEEDS MEETING.

LOCAL HON. SECRETARIES.

JAMES GRAHAM, Ph.D., *Director of Education* | Prof. A. GILLIGAN, D.Sc.

LOCAL HON. TREASURER.

JAMES MITCHELL, *City Treasurer*.

ASSISTANT LOCAL HON. SECRETARY.

J. D. GRIFFITH DAVIES, M.A.

EDITOR, GENERAL HANDBOOK.

C. B. FAWCETT, B.Litt., D.Sc.

EDITOR, EXCURSIONS HANDBOOK.

H. E. WROOT.

SECTIONAL OFFICERS.

A.—MATHEMATICAL AND PHYSICAL SCIENCES.

President.—Prof. E. T. WHITTAKER, F.R.S.

Vice-Presidents.—Dr. J. R. AIREY ; Prof. S. BRODETSKY ; Prof. A. FOWLER, F.R.S.
Prof. W. P. MILNE ; Prof. R. WHIDDINGTON, F.R.S.

Recorder.—Prof. A. M. TYNDALL.

Secretaries.—Capt. F. ENTWISTLE ; Prof. E. H. NEVILLE ; W. M. H. GREAVES.

Local Secretary.—J. EWLES.

B.—CHEMISTRY.

President.—Dr. N. V. SIDGWICK, F.R.S.

Vice-Presidents.—Dr. S. H. C. BRIGGS ; Prof. J. B. COHEN, F.R.S. ; Prof. R. W.
WHYTLAW GRAY ; Prof. J. F. THORPE, C.B.E., F.R.S.

Recorder.—Prof. C. S. GIBSON.

Secretary.—Dr. E. K. RIDEAL.

Local Secretary.—H. S. PATTERSON.

C.—GEOLOGY.

President.—Dr. HERBERT H. THOMAS, F.R.S.

Vice-Presidents.—Sir T. W. EDGEWORTH DAVID, K.B.E., C.M.G., F.R.S. ; Prof.
A. GILLIGAN ; E. HAWKESWORTH ; Prof. P. F. KENDALL, F.R.S. ; Sir F. G.
OGILVIE, C.B. ; W. PARSONS ; Prof. S. H. REYNOLDS.

Recorder.—Prof. W. T. GORDON.

Secretaries.—I. S. DOUBLE ; Dr. A. K. WELLS.

Local Secretary.—H. C. VERSEY.

D.—ZOOLOGY.

President.—Dr. G. P. BIDDER.

Vice-Presidents.—H. CROWTHER ; Prof. W. GARSTANG ; Prof. J. GRAHAM KERR,
F.R.S. ; J. W. TAYLOR.

Recorder.—Prof. F. BALFOUR BROWNE.

Secretary.—Dr. G. LESLIE PURSER.

Local Secretary.—E. PERCIVAL.

E.—GEOGRAPHY.

President.—Dr. R. N. RUDMOSE BROWN.

Vice-Presidents.—Lt.-Col. E. KITSON CLARK ; Dr. VAUGHAN CORNISH ; F. DEBENHAM ;
Dr. C. B. FAWCETT ; J. McFARLANE ; Dr. MARION NEWBIGIN ; Rt. Hon. W.
ORMSBY-GORE, P.C., M.P.

Recorder.—W. H. BARKER.

Secretary.—R. H. KINVIG.

Local Secretary.—A. V. WILLIAMSON.

F.—ECONOMICS.

President.—Prof. D. H. MACGREGOR.

Vice-Presidents.—Hon. RUPERT BECKETT ; GEOFFREY ELLIS ; Prof. T. E. GREGORY ;
Prof. J. HARRY JONES ; Sir JOSIAH STAMP, G.B.E.

Recorder.—R. B. FORRESTER.

Secretaries.—K. G. FENELON ; A. RADFORD.

Local Secretary.—C. V. DAWE.

G.—ENGINEERING.

President.—Prof. Sir J. B. HENDERSON.

Vice-Presidents.—J. H. BARKER ; T. F. BRAIME ; ALEXANDER CAMPBELL ; Prof.
W. T. DAVID ; Sir W. ELLIS, G.B.E. ; Alderman HUGH LUPTON ; Sir J. SNELL,
G.B.E. ; Major F. L. WATSON.

Recorder.—Prof. F. C. LEA.

Secretaries.—Prof. G. COOK ; J. S. WILSON.

Local Secretary.—HUGH R. LUPTON.

H.—ANTHROPOLOGY.

President.—Prof. F. G. PARSONS.

Vice-Presidents.—Prof. H. J. FLEURE ; Prof. J. K. JAMIESON ; H. B. McCALL ;
Dr. D. RANDALL McIVER.

Recorder.—E. N. FALLAIZE.

Secretaries.—L. H. DUDLEY BUXTON ; Miss R. M. FLEMING.

Local Secretary.—Prof. H. A. ORMEROD.

I.—PHYSIOLOGY.

President.—Dr. C. G. DOUGLAS, C.M.G., F.R.S.

Vice-Presidents.—Prof. J. S. HALDANE, F.R.S. ; Prof. J. B. LEATHES, F.R.S. ; Prof.
H. S. RAPER, C.B.E. ; Prof. H. E. ROAF.

Recorder.—Dr. M. H. MACKEITH.

Secretary.—Prof. B. A. MCSWINEY.

Local Secretary.—A. WORMALL.

J.—PSYCHOLOGY.

President.—Dr. W. BROWN.

Vice-Presidents.—F. C. BARTLETT ; Dr. J. DREVER ; Dr. LL. WYNN JONES ; Miss
L. A. LOWE ; Dr. C. S. MYERS, F.R.S. ; Prof. T. H. PEAR ; Dr. W. H. MAXWELL
TELLING ; Prof. GODFREY THOMSON.

Recorder.—Dr. SHEPHERD DAWSON.

Secretaries.—R. J. BARTLETT ; Dr. MAY COLLINS.

Local Secretary.—A. J. MONAHAN.

K.—BOTANY.

President.—Prof. F. E. FRITSCH.

Vice-Presidents.—Prof. V. H. BLACKMAN, F.R.S.; Prof. F. O. BOWER, F.R.S.; Dr. T. F. CHIPP; Sir PETER CLUTTERBUCK, C.I.E., C.B.E. (*Sub-section of Forestry*); Prof. J. H. PRIESTLEY; Dr. H. W. T. WAGER, F.R.S.

Recorder.—Prof. J. MCLEAN THOMPSON.

Secretaries.—Prof. W. ROBINSON; Prof. A. W. BORTHWICK (*Sub-section of Forestry*).

Local Secretary.—Miss L. I. SCOTT.

L.—EDUCATION.

President.—The DUCHESS OF ATHOLL, D.B.E., M.P.

Vice-Presidents.—Miss A. FLEMING; Dr. J. GRAHAM; J. H. HALLAM; Prof. J. STRONG, C.B.E.

Recorder.—G. D. DUNKERLEY.

Secretaries.—H. M. ICELY; E. R. THOMAS.

Local Secretary.—Miss E. M. BLACKBURN.

M.—AGRICULTURE.

President.—C. G. T. MORISON.

Vice-Presidents.—Dr. C. CROWTHER; Major J. W. DENT; Major FAWKES; Sir DANIEL HALL, K.C.B., F.R.S.; Prof. R. S. SETON.

Recorder.—Dr. G. SCOTT ROBERTSON.

Secretary.—Dr. B. A. KEEN.

Local Secretary.—W. A. MILLARD.

Hon. Secretary for Exhibit of Scientific Instruments, &c.—H. S. PATTERSON.



TABLE OF

Date of Meeting	Where held	Presidents	Old Life Members	New Life Members
1831, Sept. 27	York	Viscount Milton, D.O.L., F.R.S.	—	—
1832, June 19	Oxford	The Rev. W. Buckland, F.R.S.	—	—
1833, June 25	Cambridge	The Rev. A. Sedgwick, F.R.S.	—	—
1834, Sept. 8	Edinburgh	Sir T. M. Brisbane, D.O.L., F.R.S.	—	—
1835, Aug. 10	Dublin	The Rev. Provost Lloyd, LL.D., F.R.S.	—	—
1836, Aug. 22	Bristol	The Marquis of Lansdowne, F.R.S.	—	—
1837, Sept. 11	Liverpool	The Earl of Burlington, F.R.S.	—	—
1838, Aug. 10	Newcastle-on-Tyne	The Duke of Northumberland, F.R.S.	—	—
1839, Aug. 26	Birmingham	The Rev. W. Vernon Harcourt, F.R.S.	—	—
1840, Sept. 17	Glasgow	The Marquis of Breadalbane, F.R.S.	—	—
1841, July 20	Plymouth	The Rev. W. Whewell, F.R.S.	169	65
1842, June 23	Manchester	The Lord Francis Egerton, F.G.S.	303	169
1843, Aug. 17	Cork	The Earl of Rosse, F.R.S.	109	28
1844, Sept. 26	York	The Rev. G. Peacock, D.D., F.R.S.	226	150
1845, June 19	Cambridge	Sir John F. W. Herschel, Bart., F.R.S.	313	36
1846, Sept. 10	Southampton	Sir Roderick I. Murchison, Bart., F.R.S.	241	10
1847, June 23	Oxford	Sir Robert H. Inglis, Bart., F.R.S.	314	18
1848, Aug. 9	Swansea	The Marquis of Northampton, Pres. R.S.	149	3
1849, Sept. 12	Birmingham	The Rev. T. R. Robinson, D.D., F.R.S.	227	12
1850, July 21	Edinburgh	Sir David Brewster, K.H., F.R.S.	235	9
1851, July 2	Ipswich	G. B. Airy, Astronomer Royal, F.R.S.	172	8
1852, Sept. 1	Belfast	Lieut.-General Sabine, F.R.S.	164	10
1853, Sept. 3	Hull	William Hopkins, F.R.S.	141	13
1854, Sept. 20	Liverpool	The Earl of Harrowby, F.R.S.	238	23
1855, Sept. 12	Glasgow	The Duke of Argyll, F.R.S.	194	33
1856, Aug. 6	Cheltenham	Prof. O. G. B. Daubeny, M.D., F.R.S.	182	14
1857, Aug. 26	Dublin	The Rev. H. Lloyd, D.D., F.R.S.	236	15
1858, Sept. 22	Leeds	Richard Owen, M.D., D.O.L., F.R.S.	222	42
1859, Sept. 14	Aberdeen	H.R.H. The Prince Consort	184	27
1860, June 27	Oxford	The Lord Wrottesley, M.A., F.R.S.	286	21
1861, Sept. 4	Manchester	William Fairbairn, LL.D., F.R.S.	321	113
1862, Oct. 1	Cambridge	The Rev. Professor Willis, M.A., F.R.S.	239	15
1863, Aug. 26	Newcastle-on-Tyne	Sir William G. Armstrong, C.B., F.R.S.	203	36
1864, Sept. 13	Bath	Sir Charles Lyell, Bart., M.A., F.R.S.	287	40
1865, Sept. 6	Birmingham	Prof. J. Phillips, M.A., LL.D., F.R.S.	292	44
1866, Aug. 22	Nottingham	William R. Grove, Q.C., F.R.S.	207	31
1867, Sept. 4	Dundee	The Duke of Buccleuch, K.C.B., F.R.S.	167	25
1868, Aug. 19	Norwich	Dr. Joseph D. Hooker, F.R.S.	196	18
1869, Aug. 18	Exeter	Prof. G. G. Stokes, D.O.L., F.R.S.	204	21
1870, Sept. 14	Liverpool	Prof. T. H. Huxley, LL.D., F.R.S.	314	39
1871, Aug. 2	Edinburgh	Prof. Sir W. Thomson, LL.D., F.R.S.	246	28
1872, Aug. 14	Brighton	Dr. W. B. Carpenter, F.R.S.	245	36
1873, Sept. 17	Bradford	Prof. A. W. Williamson, F.R.S.	212	27
1874, Aug. 19	Belfast	Prof. J. Tyndall, LL.D., F.R.S.	162	13
1875, Aug. 25	Bristol	Sir John Hawkshaw, F.R.S.	239	36
1876, Sept. 6	Glasgow	Prof. T. Andrews, M.D., F.R.S.	221	35
1877, Aug. 15	Plymouth	Prof. A. Thomson, M.D., F.R.S.	173	19
1878, Aug. 14	Dublin	W. Spottiswoode, M.A., F.R.S.	201	18
1879, Aug. 20	Sheffield	Prof. G. J. Allman, M.D., F.R.S.	184	16
1880, Aug. 25	Swansea	A. C. Ramsay, LL.D., F.R.S.	144	11
1881, Aug. 31	York	Sir John Lubbock, Bart., F.R.S.	272	28
1882, Aug. 23	Southampton	Dr. C. W. Siemens, F.R.S.	178	17
1883, Sept. 19	Southport	Prof. A. Cayley, D.O.L., F.R.S.	203	60
1884, Aug. 27	Montreal	Prof. Lord Rayleigh, F.R.S.	235	20
1885, Sept. 9	Aberdeen	Sir Lyon Playfair, K.C.B., F.R.S.	225	18
1886, Sept. 1	Birmingham	Sir J. W. Dawson, C.M.G., F.R.S.	314	25
1887, Aug. 31	Manchester	Sir H. E. Roscoe, D.O.L., F.R.S.	428	86
1888, Sept. 5	Bath	Sir F. J. Bramwell, F.R.S.	266	36
1889, Sept. 11	Newcastle-on-Tyne	Prof. W. H. Flower, C.B., F.R.S.	277	20
1890, Sept. 3	Leeds	Sir F. A. Abel, C.B., F.R.S.	259	21
1891, Aug. 19	Cardiff	Dr. W. Huggins, F.R.S.	189	24
1892, Aug. 3	Edinburgh	Sir A. Geikie, LL.D., F.R.S.	280	14
1893, Sept. 13	Nottingham	Prof. J. S. Burdon Sanderson, F.R.S.	201	17
1894, Aug. 8	Oxford	The Marquis of Salisbury, K.G., F.R.S.	327	21
1895, Sept. 11	Ipswich	Sir Douglas Galton, K.C.B., F.R.S.	214	13
1895, Sept. 16	Liverpool	Sir Joseph Lister, Bart., Pres. R.S.	330	31
1897, Aug. 18	Toronto	Sir John Evans, K.C.B., F.R.S.	120	8
1898, Sept. 7	Bristol	Sir W. Crookes, F.R.S.	281	19
1899, Sept. 13	Dover	Sir Michael Foster, K.C.B., Sec. R.S.	296	20

* Ladies were not admitted by purchased tickets until 1843. † Tickets of Admission to Sections only.

[Continued on p. xii.]

ANNUAL MEETINGS.

Old Annual Members	New Annual Members	Associates	Ladies	Foreigners	Total	Amount received for Tickets	Sums paid on account of Grants for Scientific Purposes	Year
—	—	—	—	—	353	—	—	1831
—	—	—	—	—	—	—	—	1832
—	—	—	—	—	900	—	—	1833
—	—	—	—	—	1298	—	—	1834
—	—	—	—	—	—	—	£20 0 0	1835
—	—	—	—	—	1350	—	167 0 0	1836
—	—	—	—	—	1840	—	435 0 0	1837
—	—	—	—	—	2400	—	922 12 6	1838
—	—	—	1100*	—	1438	—	932 2 2	1839
—	—	—	—	34	1353	—	1595 11 0	1840
—	—	—	—	40	891	—	1546 16 4	1841
46	317	—	60*	28	1315	—	1235 10 11	1842
75	376	33†	331*	—	—	—	1449 17 8	1843
71	185	—	160	—	—	—	1565 10 2	1844
45	190	9‡	260	—	—	—	981 12 8	1845
94	22	407	172	35	1079	—	831 9 9	1846
65	39	270	196	36	857	—	685 16 0	1847
197	40	495	203	53	1320	—	208 5 4	1848
54	25	376	197	15	819	£707 0 0	275 1 8	1849
93	33	447	237	22	1071	963 0 0	159 19 6	1850
128	42	510	273	44	1241	1085 0 0	345 18 0	1851
61	47	244	141	37	710	620 0 0	391 9 7	1852
63	60	510	292	9	1108	1085 0 0	304 6 7	1853
56	57	367	236	6	876	903 0 0	205 0 0	1854
121	121	765	524	10	1802	1882 0 0	380 19 7	1855
142	101	1094	543	26	2133	2311 0 0	480 16 4	1856
104	48	412	346	9	1115	1098 0 0	734 13 9	1857
156	120	900	569	26	2022	2015 0 0	507 15 4	1858
111	91	710	509	13	1698	1931 0 0	618 18 2	1859
125	179	1206	821	22	2564	2782 0 0	684 11 1	1860
177	59	636	463	47	1689	1604 0 0	766 19 6	1861
184	125	1589	791	15	3138	3944 0 0	1111 5 10	1862
150	57	433	242	25	1161	1089 0 0	1293 16 6	1863
154	209	1704	1004	25	3335	3640 0 0	1608 3 10	1864
182	103	1119	1058	13	2802	2965 0 0	1289 15 8	1865
215	149	766	508	23	1997	2227 0 0	1591 7 10	1866
218	105	960	771	11	2303	2469 0 0	1750 13 4	1867
193	118	1163	771	7	2444	2613 0 0	1739 4 0	1868
226	117	720	682	45‡	2004	2042 0 0	1940 0 0	1869
229	107	678	600	17	1856	1931 0 0	1622 0 0	1870
303	195	1103	910	14	2878	3096 0 0	1572 0 0	1871
311	127	976	754	21	2463	2575 0 0	1472 2 6	1872
280	80	937	912	43	2533	2649 0 0	1285 0 0	1873
237	99	796	601	11	1983	2120 0 0	1685 0 0	1874
232	85	817	630	12	1951	1979 0 0	1151 16 0	1875
307	93	884	672	17	2248	2397 0 0	960 0 0	1876
331	185	1265	712	25	2774	3023 0 0	1092 4 2	1877
238	59	446	283	11	1229	1268 0 0	1128 9 7	1878
290	93	1285	674	17	2578	2615 0 0	725 16 6	1879
239	74	529	349	13	1404	1425 0 0	1080 11 11	1880
171	41	389	147	12	915	899 0 0	731 7 7	1881
313	176	1230	514	24	2557	2689 0 0	476 8 1	1882
253	79	516	189	21	1253	1286 0 0	1126 1 11	1883
330	323	952	841	5	2714	3369 0 0	1083 3 3	1884
317	219	826	74	26 & 60 H. §	1777	1855 0 0	1173 4 0	1885
332	122	1053	447	6	2203	2256 0 0	1385 0 0	1886
428	179	1067	429	11	2453	2532 0 0	995 0 6	1887
510	244	1985	493	92	3838	4336 0 0	1186 18 0	1888
399	100	639	509	12	1984	2107 0 0	1511 0 5	1889
412	113	1024	579	21	2437	2441 0 0	1417 0 11	1890
368	92	680	334	12	1775	1776 0 0	789 16 8	1891
341	152	672	107	35	1497	1664 0 0	1029 10 0	1892
413	141	733	439	50	2070	2007 0 0	864 10 0	1893
328	57	773	268	17	1661	1653 0 0	907 15 6	1894
435	69	941	451	77	2321	2175 0 0	583 15 6	1895
290	31	493	261	22	1324	1236 0 0	977 15 5	1896
383	139	1384	873	41	3181	3228 0 0	1104 6 1	1897
286	125	682	100	41	1362	1398 0 0	1059 10 8	1898
327	96	1051	639	33	2446	2399 0 0	1212 0 0	1899
324	68	548	120	27	1403	1328 0 0	1430 14 2	1899

‡ Including Ladies. § Fellows of the American Association were admitted as Hon. Members for this Meeting.

[Continued on p. xiii.]

Table of

Date of Meeting	Where held	Presidents	Old Life Members	New Life Members
1900, Sept. 5	Bradford	Sir William Turner, D.O.L., F.R.S.	267	13
1901, Sept. 11	Glasgow	Prof. A. W. Rücker, D.Sc., Sec.R.S.	310	37
1902, Sept. 10	Belfast	Prof. J. Dewar, LL.D., F.R.S.	243	21
1903, Sept. 9	Southport	Sir Norman Lockyer, K.C.B., F.R.S.	250	21
1904, Aug. 17	Cambridge	Rt. Hon. A. J. Balfour, M.P., F.R.S.	419	32
1905, Aug. 15	South Africa	Prof. G. H. Darwin, LL.D., F.R.S.	115	40
1906, Aug. 1	York	Prof. E. Ray Lankester, LL.D., F.R.S.	322	10
1907, July 31	Leicester	Sir David Gill, K.O.B., F.R.S.	276	19
1908, Sept. 2	Dublin	Dr. Francis Darwin, F.R.S.	294	24
1909, Aug. 25	Winnipeg	Prof. Sir J. J. Thomson, F.R.S.	117	13
1910, Aug. 31	Sheffield	Rev. Prof. T. G. Bonney, F.R.S.	293	26
1911, Aug. 30	Portsmouth	Prof. Sir W. Ramsay, K.C.B., F.R.S.	284	21
1912, Sept. 4	Dundee	Prof. E. A. Schäfer, F.R.S.	288	14
1913, Sept. 10	Birmingham	Sir Oliver J. Lodge, F.R.S.	376	40
1914, July-Sept.	Australia	Prof. W. Bateson, F.R.S.	172	13
1915, Sept. 7	Manchester	Prof. A. Schuster, F.R.S.	242	19
1916, Sept. 5	Newcastle-on-Tyne	Sir Arthur Evans, F.R.S.	164	12
1917	(No Meeting)		—	—
1918	(No Meeting)		—	—
1919, Sept. 9	Bournemouth	Hon. Sir O. Parsons, K.O.B., F.R.S.	235	47
1920, Aug. 24	Cardiff	Prof. W. A. Herdman, C.B.E., F.R.S.	288	11
1921, Sept. 7	Edinburgh	Sir T. E. Thorpe, O.B., F.R.S.	336	9
1922, Sept. 6	Hull	Sir C. S. Sherrington, G.B.E., Pres. R.S.	228	13
1923, Sept. 12	Liverpool	Sir Ernest Rutherford, F.R.S.	326	12
1924, Aug. 6	Toronto	Sir David Bruce, K.C.B., F.R.S.	119	7
1925, Aug. 26	Southampton	Prof. Horace Lamb, F.R.S.	280	8
1926, Aug. 4	Oxford	H.R.H. The Prince of Wales, K.G., F.R.S.	358	9
1927, Aug. 31	Leeds	Sir Arthur Keith, F.R.S.	249	9

¹ Including 848 Members of the South African Association.

² Including 137 Members of the American Association.

³ Special arrangements were made for Members and Associates joining locally in Australia, see Report, 1914, p. 686. The numbers include 80 Members who joined in order to attend the Meeting of L'Association Française at Le Havre.

⁴ Including Students' Tickets, 10s.

⁵ Including Exhibitioners granted tickets without charge.

Annual Meetings—(continued).

Old Annual Members	New Annual Members	Associates	Ladies	Foreigners	Total	Amount received for Tickets	Sums paid on account of Grants for Scientific Purposes	Year
297	45	801	482	9	1915	£1801 0	£1072 10 0	1900
374	131	794	246	20	1912	2046 0	920 9 11	1901
314	86	647	305	6	1620	1644 0	947 0 0	1902
319	90	688	365	21	1754	1762 0	845 13 2	1903
449	113	1338	317	121	2789	2650 0	887 18 11	1904
937 ¹	411	430	181	16	2130	2422 0	928 2 2	1905
356	93	817	352	22	1972	1811 0	882 0 9	1906
339	61	659	251	42	1647	1561 0	757 12 10	1907
465	112	1166	222	14	2237	2317 0	1157 18 8	1908
290 ²	162	789	90	7	1468	1623 0	1014 9 9	1909
379	57	563	123	8	1449	1439 0	963 17 0	1910
349	61	414	81	31	1241	1176 0	922 0 0	1911
368	95	1292	359	88	2504	2349 0	845 7 6	1912
480	149	1287	291	20	2643	2756 0	978 17 1	1913
139	4160 ³	539 ³	—	21	5044 ³	4873 0	1861 16 4 ⁶	1914
287	116	628 ⁴	141	8	1441	1406 0	1569 2 8	1915
250	76	251 ⁴	73	—	826	821 0	985 18 10	1916
—	—	—	—	—	—	—	677 17 2	1917
—	—	—	—	—	—	—	326 13 3	1918
254	102	688 ⁴	153	3	1482	1736 0	410 0 0	1919

Old Annual Regular Members	Annual Members		Transferable Tickets	Students Tickets		Total	Amount received	Sums paid on account of Grants for Scientific Purposes	Year
	Meeting and Report	Meeting only							
136	192	571	42	120	20	1380	1272 10	1251 13 0 ⁸	1920
133	410	1394	121	343	22	2768	2599 15	518 1 10	1921
90	294	757	89	235 ⁵	24	1730	1699 5	772 0 7	1922
123	380	1434	163	550	308 ⁷	3296	2735 15	777 18 6 ⁹	1923
37	520	1866	41	89	139	2818	3165 19 ¹⁰	1197 5 9	1924
97	264	878	62	119	74	1782	1630 5	1231 0 0	1925
101	453	2338	169	225	69	3722	3542 0	917 1 6	1926
84	334	1487	82	264	161	2670	2414 5	751 10 0	1927

⁶ Including grants from the Caird Fund in this and subsequent years.⁷ Including Foreign Guests, Exhibitioners, and others.⁸ The Bournemouth Fund for Research, initiated by Sir O. Parsons, enabled grants on account of scientific purposes to be maintained.⁹ Including grants from the Caird Gift for research in radioactivity in this and subsequent years to 1926.¹⁰ Subscriptions paid in Canada were \$5 for Meeting only and others pro rata; there was some gain on exchange.

REPORT OF THE COUNCIL, 1926-27.

I. The Council in November last took the earliest opportunity of acknowledging the deep obligation of the Association to Sir Alfred Yarrow in the following terms :—

That the Council places upon record its profound gratitude to Sir Alfred Yarrow for his munificent gift of £10,000 to the funds of the Association for general purposes; that the Council welcomes the wise condition made by Sir Alfred Yarrow that the gift should be expended as to both capital and interest within twenty years, and resolves that effect shall be given thereto.

II. The Council places upon record its grateful memory of the late Prof. A. W. Scott, of Lampeter, a regular attendant at the meetings of the Association for many years, who by his will devised the sum of £250 to the funds of the Association.

Among other supporters and former office-bearers, the Council has had to deplore the loss by death of Sir William Ashley, Prof. A. W. Crossley, Prof. F. W. Gamble, Sir George Greenhill, Dr. E. Sidney Hartland, Sir John Scott Keltie, Mr. G. W. Lamplugh, Mr. J. J. Lister, Mr. Edwin Ransom (who became a life member in 1868), Sir William Ridgeway, Prof. E. H. Starling, Sir William Tilden, Gen. Sir Charles Warren, and the Rev. P. H. Wicksteed.

III. Prof. Sir William Bragg, F.R.S., has been unanimously nominated by the Council to fill the office of President of the Association for the year 1928-29 (Glasgow Meeting).

IV. Representatives of the Association have been appointed as follows :—

International Congress of Plant Sciences	Prof. A. W. Hill and Dr. A. B. Rendle.
Deutsche Naturforscher, Düsseldorf Meeting	Dr. J. G. Garson.
American Association for the Advancement of Science	Prof. J. L. Myres.
Royal Sanitary Institute, Hastings Meeting	Mr. T. S. Dymond, Mayor of Hastings.
Royal Microscopical Society, Liverpool Meeting	Prof. J. McLean Thompson.
American Philosophical Society, second Centenary	Prof. A. N. Whitehead.
Lister Centenary	Sir E. Sharpey-Schafer.
University College, London, Centenary	Prof. Sir A. Keith.

V. Resolutions referred by the General Committee at the Oxford Meeting to the Council for consideration, and, if desirable, for action, were dealt with as follows :—

(a) The Council requested Dr. J. R. Airey to consider whether, in the event of the Association's undertaking to republish the reports of the Mathematical Tables Committee in collected form, it would be advantageous to include tables published by other institutions by arrangement with such institutions. This matter is expected to come up for further consideration at the Leeds Meeting (Resolution of Section A).

(b) The Council has had under discussion with the Board of Trade the question of the duty required by H.M. Customs on the introduction of cinematograph films into this country for scientific purposes and not

intended for commercial uses. The matter was referred to the Lords Commissioners of H.M. Treasury, from whom a reply was received that 'having regard to the impracticability of framing a statutory exemption which would be free from grave difficulties of definition and administration,' they were unable 'to submit to Parliament proposals of the nature desired by the Association.' (Resolutions of Sections D and H and the Conference of Delegates of Corresponding Societies.)

(c) The Council received from Lord Clinton and Dr. T. F. Chipp the fullest assistance in investigating the disastrous effects which follow the destruction of hill slopes in tropical hill-regions, and a statement drawn up by Lord Clinton was forwarded to H.M. Secretary of State for the Colonies for communication to the Colonial authorities concerned. The statement was also ordered to be printed in the Report of the Council, and is as follows (Resolution of Section K) :—

Owing to strict limitation in the programme the only aspect of this question which it was possible to consider at the Meeting at Oxford was the destruction of forest on hill slopes.

Reports, articles in the local Press of countries, periodicals and statements of eye-witnesses all bear witness to the continued prevalence of this practice and emphasise the consequent loss sustained by many of our tropical Colonies.

The destruction of these hillside forests is due to several causes: the natives destroying the forest by fire in the annual burning preceding their hunting; the native agriculturalist destroying the forest in the course of his shifting cultivation; the farmer encouraging young pasture grass for his cattle; or over-grazing old pastures; or again the agriculturalist, practising a more intensive system of agriculture, who replaces the forest by permanent crops such as rubber, coffee or tea.

Whatever be the cause, the ultimate result is the same. Impoverishment of the soil is effected by destruction of organic matter by fire. The torrential rains soon leach the exposed soil surface and very quickly remove it entirely to the valleys below. The bare exposed rocks heated by the sun tend to disperse the rain clouds and the daily temperature variation becomes extreme. The hillside is freely exposed to the action of every wind with the consequent desiccation of the atmosphere. The rain water rushes destructively down the slopes almost as soon as it falls, scouring the mountain sides, cutting into neighbouring farms and depositing broad beds of silt in the lower part of its course. Such impoverished hillsides soon become barren and the headwaters of the rivers become seriously affected. In the low-lying ground the silt brought down chokes the ordinary river channel so that the water spreads over the valleys, causing inundations both periodic and permanent, with the destruction of lowland vegetation, crops and even towns.

Where plantations replace the forest the process is more gradual, but without protective measures the soil is continuously removed from the clean-weeded ground and the roots of the trees freely exposed so that the crop becomes stunted and valueless.

All this tends to the impoverishment of a country, the gradual drying up of the highlands and the conversion of the lowlands into swamps, the spoliation of agriculture with the failure of the population to find land on which to support itself, for the hillsides become unstable or more frequently barren rocky slopes.

Afforestation as a remedy is a big problem and in country of this nature requires the advice of expert foresters, and a long period must elapse before its effects can be realised. Intensive agriculturalists, as in Ceylon, when the terrain permits, resort at great expense to terracing, generally with the aid of cover crops.

The argument it is now desired to emphasise is that every effort should be made to prevent such destruction rather than wait till destruction has taken place and then try to remedy the error. Prevention entails preliminary reconnaissance and the scheduling of areas likely to prove dangerous, where, in the interests of the country, it is not expedient that the natural vegetation shall be removed.

CLINTON,

*Chairman of the Forestry Sub-section,
British Association.*

(d) In order to give effect to the Resolution of Sections L and M, asking that public attention be drawn to the need for preparation for overseas life in schools, etc., the Council took measures to bring to the notice of appropriate Government authorities and educational associations the reports of the Overseas Training Committee and of the discussion on overseas training at the Oxford Meeting.

(e) The Council received from Sir John Flett a statement on the value of records of temporarily open geological sections, and circulated it to the Corresponding Societies. (Resolution of the Conference of Delegates of Corresponding Societies.)

VI. The Council has to report that the claims for remission of income tax by the two societies taken as test cases,¹ viz., the Geologists' Association and the Midland Counties Institution of Engineers, have been rejected by the Special Commissioners for Income Tax. The cases are in preparation for presentation in the High Court.

VII. As previously reported (1925-26, x), the Council, in co-operation with the British Science Guild, caused a Conference, representative of learned societies and scientific institutions in London, to be called to consider the desirability and possibility of establishing a Science News Service for the Press. The matter has been further under consideration, and a report, presented to the Conference by a committee thereof, was published in the *Journal* of the British Science Guild, July, 1927. The Council, however, after full inquiry, has decided not to take any further action toward the establishment of such a service.

VIII. The Council appointed a committee to consider and report upon the advisability of approaching the British Science Guild with a view to establishing closer relations. Having received the report of this committee, the Council resolved to 'invite the co-operation of the British Science Guild in considering whether, having regard to the close community of scientific interests between the Association and the Guild, their objects would, as the Council believe, be more fully attained by means of a working union between the two societies; and if so, by what means such union would best be given effect.' The Guild proposed a joint committee to consider this resolution, and the Council appointed thereto Lord Bledisloe, Dr. C. S. Myers, Prof. T. P. Nunn, and Prof. A. Smithells, together with the General Secretaries. The Council has received a report from this joint committee, and will report further in due course to the General Committee.

IX. The Council has received reports from the General Treasurer throughout the year. His accounts have been audited and are presented to the General Committee. The Council made the following grants to research committees from the Caird Fund:—

Naples Table ...	£100	Seismology ...	£100
------------------	------	----------------	------

and a donation of £25 towards the expenses of the Royal Anthropological Institute's expedition to the Abyssinian frontier.

X. The Corresponding Societies Committee has been nominated as follows: the President of the Association (*Chairman ex-officio*), Mr. T.

¹ See *Report of the Council, 1925-26, xii.*

Sheppard (*Vice-Chairman*), the General Treasurer, the General Secretaries, Dr. F. A. Bather, Sir R. A. Gregory, Sir D. Prain, Sir J. Russell, Mr. Mark Sykes, Dr. C. Tierney.

XI. The retiring Ordinary Members of the Council are: Sir W. H. Beveridge, Prof. C. H. Desch, Prof. H. J. Fleure, Prof. A. W. Porter, Sir J. Russell.

The Council nominates the following new members: Dr. N. V. Sidgwick, Dr. G. C. Simpson, Prof. T. B. Wood; leaving two vacancies to be filled by the General Committee without nomination by the Council.

The full list of nominations of Ordinary Members is as follows:—

Prof. J. H. Ashworth.	Sir T. H. Holland.
Rt. Hon. Lord Bledisloe.	Sir H. G. Lyons.
Prof. A. L. Bowley.	Dr. C. S. Myers.
Prof. E. G. Coker.	Prof. T. P. Nunn.
Prof. W. Dalby.	Prof. A. O. Rankine.
Dr. H. H. Dale.	Prof. A. C. Seward.
Mr. E. N. Fallaize.	Dr. F. C. Shruballs.
Sir J. S. Flett.	Dr. N. V. Sidgwick.
Sir R. A. Gregory.	Dr. G. C. Simpson.
Mr. C. T. Heycock.	Prof. A. Smithells.
Prof. J. P. Hill.	Prof. T. B. Wood.
Mr. A. R. Hinks.	

XII. The General Officers have been nominated by the Council as follows:—

General Treasurer, Dr. E. H. Griffiths.

General Secretaries, Prof. J. L. Myres, Dr. F. E. Smith.

The Council during its present session has been unhappily deprived of the presence of Dr. E. H. Griffiths, General Treasurer, at its meetings owing to ill-health, though he has fortunately been able to retain his office at the request of the Council, from which he has received an expression of its sympathy and an assurance of its deep sense of the value of his services.

XIII. The following have been admitted as members of the General Committee: Dr. F. A. E. Crew, Prof. David Ellis, Prof. A. D. Peacock, Mr. F. W. Shurlock, Dr. A. B. Walkom, Dr. W. Wardlaw.

XIV. The Council having received the instructions of the General Committee to make the necessary inquiries relating to the invitation from South Africa for the year 1929, the General Secretaries have been in correspondence with the South African Association for the Advancement of Science. They had also an opportunity, kindly arranged by Lord Bledisloe, of meeting General Hertzog, the Prime Minister of the Union of South Africa, and of discussing with him the prospects of, and arrangements for, a meeting in South Africa. The General Secretaries have further collected particulars as to dates, duration and extent of the journey, costs of transport and maintenance, etc., and a separate report upon these will be furnished to the General Committee at the Leeds Meeting. The Council has approved in principle the acceptance of the invitation and recommends the General Committee accordingly.

XV. The Council has received with satisfaction intimations of the intention of the city and university of Bristol to invite the Association to meet there in 1930, and of the city of Leicester to invite the Association to meet there in 1932.

GENERAL MEETINGS, ETC., IN LEEDS.

The Inaugural General Meeting was held on Wednesday, August 31, 1927, at 8.30 p.m., in the Majestic Theatre. In the absence in Canada of H.R.H. The Prince of Wales, K.G., F.R.S., the retiring President, the chair was taken at the outset by Sir Oliver Lodge, F.R.S. After the Lord Mayor of Leeds and the Vice-Chancellor of the University of Leeds had welcomed the Association, Sir Oliver Lodge read the message which follows from the retiring President:—

A MESSAGE FROM H.R.H. THE PRINCE OF WALES, K.G., F.R.S., ON LAYING DOWN THE PRESIDENCY OF THE ASSOCIATION.

My year of office as President of the British Association has come to an end, and I can only express my regret to the members of the Association, and to our hosts the City and University of Leeds, that I am unable to attend personally in order to take my leave.

At Oxford last year I ventured in my address to lay before the meeting a view of the relations between Science and the State. I felt subsequently some justification for having chosen this topic, when I observed in the proceedings of the Imperial and Colonial Conferences of the past year the extraordinary emphasis laid upon the value of scientific research in relation to imperial development. Both conferences set up special committees on research, and we cannot but believe and rejoice that the foundations of an imperial scientific service are being firmly laid. The Prime Minister of Australia indicated 'the application of science both to our primary and secondary industries' as 'the most important thing for Empire trade'; more recently our ex-president, the Earl of Balfour, invited the attention of the House of Lords to 'the enormous value of the work given by men of science, with the most lavish generosity,' to the study of problems of the common welfare.

Such events as these place it beyond doubt that one of the main objects of the British Association itself is in process of achievement namely, that of 'obtaining more general attention for the objects of science.' The Association, the so-called parliament of science, is one of the chief instruments to that end, and I trust that the public support will continue, in increasing measure, to be accorded to its work. Its powers, I am happy to say, have been very materially strengthened, during my own term of office, through the splendid generosity of Sir Alfred Yarrow, in making a gift of £10,000 for the general purposes of the Association, to be expended, in accordance with his wise provision, in the course of twenty years. I gladly take this opportunity of publicly repeating the thanks of the Association to Sir Alfred Yarrow.

In resigning the chair to Sir Arthur Keith, I can whole-heartedly congratulate the Association on its choice of my successor. His name stands very high in the science of man's origin and early biological history. I have reason to believe that when anyone in this country digs up a bone his first instinct (subject to the intervention of the police) is to send it to Sir Arthur Keith. You are to hear from him an address on Darwinism as it stands to-day—a subject of perennial interest, and more than once one of warm controversy at our own meetings. The occasion of the

Presidential Address does not (I am thankful to say) lend itself to controversy, but the warmth I am sure you will supply in your welcome to Sir Arthur Keith, and, meeting as you are in Leeds, that warmth will be increased by the traditional quality of Yorkshire hospitality.

(Signed) EDWARD P., *President*.

Prof. Sir Arthur Keith, F.R.S., then assumed the Presidency of the Association, and delivered an Address (for which see page 1) on 'Darwin's Theory of Man's Descent as it stands to-day.' A vote of thanks was proposed by Prof. Sir William Boyd-Dawkins, F.R.S., and the President, in his reply, uttered a plea for funds to ensure the preservation of Darwin's residence at Downe. He was able to announce to the General Committee at its final meeting (September 6) that this provision had been obtained through the munificence of Mr. George Buckston Browne.

On Thursday evening, September 1, a reception was given by the Lord Mayor and Lady Mayoress of Leeds, which was honoured by the presence of H.R.H. The Princess Mary, Viscountess Lascelles. On Tuesday evening, September 6, a reception was given in the University by the Pro-Chancellor and Mrs. Tetley and the Vice-Chancellor and Mrs. Baillie.

An exhibition of scientific instruments was arranged in the Town Hall during the meeting, and demonstrations of noctovision and television were given by Mr. J. C. Baird in the Education Department, and of educational broadcasting by the British Broadcasting Corporation.

EVENING DISCOURSES.

Prof. R. A. Millikan : 'Cosmic Rays.' 8 p.m., September 2, Albert Hall.

Dr. F. A. E. Crew : 'The Germplasm and its Architecture.' 8 p.m., September 5, Albert Hall.

CITIZENS' LECTURES.

Dr. Macgregor Skene : 'By-products of Plant Activity.' 8 p.m., September 2, Philosophical Hall.

Sir Oliver Lodge, F.R.S. : 'Energy.' 8 p.m., September 6, Albert Hall.

LECTURES TO YOUNG PEOPLE.

Mr. F. Kingdon Ward : 'Plant Hunting on the Roof of the World.' 3 p.m., September 2, Albert Hall.

Dr. C. Tierney : 'Nature's Secrets.' 10.30 a.m., September 5, Majestic Theatre.

CONCLUDING GENERAL MEETING.

The Concluding General Meeting was held in the Albert Hall on Wednesday, September 7, at 12 noon, when the following resolutions were adopted with acclamation :—

That the British Association desires most warmly to thank the Citizens and Corporation of the City of Leeds, through the Right Honourable the Lord Mayor, for the City's generous hospitality on the occasion of the Meeting of the Association in 1927. The Association deeply appreciates the unrestricted facilities afforded to its members to acquaint themselves with the manifold economic industrial and other

scientific interests of the City and locality, and is grateful for the use of the many fine buildings placed at its disposal for its Meeting. Especially does the Association acknowledge the powerful aid of the City's Education Department and its able staff, on whose unremitting labour so much of the successful organisation of the Meeting has depended.

That the British Association most gratefully acknowledges the generous co-operation and hospitality of the University of Leeds, through its Vice-Chancellor, on the occasion of the Meeting in 1927. The Association fully recognises that the unremitting work of many members of the University staff, the ample accommodation afforded by the University buildings, and the generous reception of the members of the Association, have contributed in large measure to the success of a very notable Meeting.

A vote of thanks was accorded to the General Officers of the Association on the motion of Sir Henry Fowler, K.B.E.

EXTERNAL LECTURES.

Public Lectures were given in connection with the Leeds Meeting as follow :—

To Adults.

Guiseley . . .	Sept. 1 .	Dr. G. H. Miles . . .	Industrial Psychology.
Brighouse . . .	Sept. 2 .	Prof. O. H. T. Rishbeth . . .	Aspects of Life and Economics in Northern China.
Pontefract . . .	Sept. 2 .	Prof. P. F. Kendall . . .	Geology and Coal Resources of the Pontefract District.
Otley	Sept. 2 .	Prof. J. L. Myres	The Place of Women in Simple Societies.
Harrogate . . .	Sept. 2 } .	Mr. L. H. Dudley Buxton	{ China: the Land and the People.
Wakefield . . .	Sept. 6 } .		
Castleford . . .	Sept. 5 .	Prof. H. J. Fleure	The Evolution of Human Races and their Societies.
Batley	Sept. 6 .	Mr. F. Kingdon Ward	Plant Hunting on the Roof of the World.
Huddersfield . . .	Sept. 6 .	Mr. H. J. E. Peake	The Beginnings of Civilisation.

To Young People.

Otley	Sept. 1 .	Mr. W. W. Jervis	Travels in Higher Latitudes.
Keighley	Sept. 2 } .	Prof. W. Garstang	The Songs of the Birds.
Shipley	Sept. 5 } .		
Pontefract . . .	Sept. 2 .	Prof. F. Balfour Browne	Domestic Affairs of Caterpillars.
Harrogate	Sept. 2 .	Dr. C. J. Patten	The Language of Birds: its Mechanism and Interpretation.
Batley	Sept. 2 .	Miss R. M. Fleming	Old Time Tales.
Wakefield	Sept. 6 .	Prof. B. H. Bentley	Flowers: their Message to the Young.

BRITISH ASSOCIATION EXHIBITIONS.

These were awarded on the general lines of previous years, but representatives from Oxford and Cambridge were included for the first time. It is hoped that the scheme may now be regarded as permanently established.

BRITISH ASSOCIATION FOR THE ADVANCEMENT
OF SCIENCE.

GENERAL TREASURER'S ACCOUNT

JULY 1, 1926, TO JUNE 30, 1927.

Corresponding Figures June 30, 1926. £ s. d.		LIABILITIES.		£ s. d.		£ s. d.			
		To Capital Accounts—							
		General Fund—							
		As at June 30, 1926	10,575	15	2				
		John Perry Guest Fund . . .	£75	0	0				
		Less Grant to Prof. Michotte	10	0	0				
10,575	15	2				10,640	15	2	
		As per contra (Subject to Depreciation in Value of Investments)							
		„ Caird Fund—				9,582	16	3	
		As per contra (Subject to Depreciation in Value of Investments)							
9,582	16	3							
		„ Caird Fund Revenue Account—							
		Balance as at July 1, 1926 . . .	470	4	10				
		Add Excess of Income over Expenditure for year	164	11	8				
470	4	10				634	16	6	
52	3	11				52	3	11	
		„ Caird Gift, Radio-Activity Investigation							
		„ Sir F. Bramwell's Gift for Enquiry into Prime Movers, 1931—				69	3	3	
		£50 Consols now accumulated to £138 14s. 11d., as per contra							
65	16	0							
10,000	0	0				10,000	0	0	
		„ Sir Alfred Yarrow's Gift				10,000	0	0	
		„ John Perry Guest Fund							
75	0	0							
		„ Life Compositions—							
		As at July 1, 1926	933	12	2				
		Add Received during year	195	0	0				
933	12	2				1,128	12	2	
450	0	0							
		„ Legacy—F. W. Backhouse	182	18	10				
		„ Toronto University Presentation Fund	8	15	0				
		Add Dividends							
			191	13	10				
		Less Awards given	9	12	6				
182	18	10				182	1	4	
		„ Income and Expenditure Account—							
		Balance as at July 1, 1926	4,544	18	6				
		Add Legacy—F. W. Backhouse, now in- vested in $3\frac{1}{2}$ per cent. Conversion Stock	450	0	0				
		Add Excess of Income over Expenditure for the year	1,032	2	10				
4,544	18	6				6,027	1	4	
<u>36,933</u>		5	8			<u>£48,317</u>		9	11

I have examined the foregoing Accounts with the Books and Vouchers and certify the same

Approved,
A. W. KIRKALDY, }
A. O. RANKINE, } Auditors.

July 12, 1927.

June 30, 1927.

Corresponding Figures June 30, 1926. £ s. d.	ASSETS.	£ s. d.	£ s. d.
	By Investments on Capital Accounts—General Fund—		
	£1,651 10s. 5d. Consolidated 2½ per cent. Stock at cost	3,942 3 3	
	£3,600 India 3 per cent. Stock at cost	3,522 2 6	
	£879 14s. 9d. £43 Great Indian Peninsula Railway 'B' Annuity at cost	827 15 0	
	£52 12s. 7d. War Stock (Post Office Issue) at cost	54 5 2	
	£834 16s. 6d. 4½ per cent. Conversion Loan at cost	835 12 4	
	£1,400 War Stock 5 per cent. 1929/47 at cost	1,393 16 11	
	John Perry Guest Fund—		
	£96 National Savings Certificates	£74 8 0	
	12 Less Sale of ditto	11 13 0	
	£84	£62 15 0	
		62 15 0	
		10,638 10 2	
	£7,880 18s. 8d. Value at date, £7,931 19s. 11d.		
10,575 15 2	Balance Uninvested. Cash at Bank	2 5 0	10,640 15 2
	„ Caird Fund—		
	£2,627 0s. 10d. India 3½ per cent. Stock at cost	2,400 13 3	
	£2,100 London Midland and Scottish Railway Consolidated 4 per cent. Preference Stock at cost	2,190 4 3	
	£2,500 Canada 3½ per cent. 1930/50 Registered Stock at cost	2,397 1 6	
9,582 16 3	£2,000 Southern Railway Consolidated 5 per cent. Preference Stock at cost	2,594 17 3	9,582 16 3
	£7,045 6s. 1d. Value at date, £7,116 15s. 10d.		
470 4 10	„ Caird Fund Revenue Account—		
	Cash at Bank		634 16 6
52 3 11	„ Caird Gift—		
	Cash at Bank		52 3 11
	„ Sir F. Bramwell's Gift—		
	£132 12 9 Self-Accumulating Consolidated Stock as per last Balance Sheet	65 16 0	
	6 2 2 Add Accumulations to June 30, 1927	3 7 3	
65 16 0	£138 14 11		69 3 3
	Value at date, £75 5s. 4d.		
10,000 0 0	„ Sir Charles Parsons' Gift—		
	£10,300 4½ per cent. Conversion Loan		10,000 0 0
	£9,888. Value at date, £9,888		
	„ Sir Alfred Yarrow's Gift—		
	£10,000 5 per cent. War Loan (£50 Bonds) 1929/47		10,169 7 0
75 0 0	Value at date, £10,087 10s. 0d.		
	„ John Perry Guest Fund		—
	„ Life Compositions—		
	£1,733 10s. 7d. Local Loans at cost	1,125 0 0	
	Value at date, £1,100 15s. 9d.		
933 12 2	Cash at Bank	3 12 2	1,128 12 2
450 0 0	„ Legacy—T. W. Backhouse		
	„ Toronto University Presentation Fund—		
	£175 5 per cent. War Stock at cost	173 11 4	
	Value at date, £176 10s. 7d.		
182 18 10	Cash at Bank	3 10 0	182 1 4
	„ Revenue Account—		
	£2,098 1s. 9d. Consolidated 2½ per cent. Stock at cost	1,200 0 0	
	£4,338 6s. 2d. Conversion 3½ per cent. Stock at cost	3,300 0 0	
	Value at date, £4,429 18s. 1d.		
	Sundry Debtors	197 3 10	
	Cash at Bank	1,147 16 5	
4,544 18 6	Cash in Hand	12 14 1	5,857 14 4
36,933 5 8			£48,317 9 11

to be correct. I have also verified the Balances at the Bankers and the Investments.

W. B. KEEN,
Chartered Accountant.

Income and
FOR THE YEAR ENDED

Corresponding Figures June 30, 1926.	EXPENDITURE.			
£ s. d.		£ s. d.	£ s. d.	
25 13 2	To Heat, Light and Power	20 16 8½		
71 5 7	„ Stationery	65 18 5		
1 0 0	„ Rent	1 0 0		
140 12 7	„ Postages	180 2 11		
121 15 5	„ Travelling Expenses	149 0 11		
36 12 9	„ Exhibitioners	30 10 6		
187 3 4	„ General Expenses	205 2 9½		
584 2 10		652 12 3		
1,184 19 2	„ Salaries and Wages	1,254 17 0		
75 0 0	„ Pension Contribution	75 0 0		
1,466 17 5	„ Printing, Binding, etc.	1,566 8 5		
3,310 19 5			3,548 17 8	
	„ Grants to Research Committees—			
	Quaternary Peat Committee	80 0 0		
	Macedonia Committee	40 0 0		
	Growth of Children Committee	25 0 0		
	Plymouth Committee	35 0 0		
	Derbyshire Caves Committee	25 0 0		
	Bronze Implements Committee	90 0 0		
	Egyptian Peasants Committee	20 0 0		
	Marine Algæ Committee	45 0 0		
	Vasoligation Committee	10 0 0		
	Sex Ratio Committee	10 0 0		
	Zoological Record Committee	50 0 0		
	Pigment in Insecta Committee	15 0 0		
	Illumination of Plants Committee	40 0 0		
	Triplets Committee	20 0 0		
	Earth Pressures Committee	10 0 0		
	Dolgarrog Committee	5 0 0		
	Medullary Centres Committee	20 0 0		
	Geography Teaching Committee	5 0 0		
	African Geography Committee	2 10 0		
	Vocational Tests Committee	14 0 0		
170 11 6		561 10 0		
1,327 2 8	„ Balance, being Excess of Income over Expenditure for the year		1,032 2 10	
4,808 13 7			£5,142 10 6	

		EXPENDITURE.		Caird	
£ s. d.		£ s. d.	£ s. d.		
	To Grants Paid—				
	Seismology Committee	100 0 0			
	Naples Tables Committee	100 0 0			
546 10 0				200 0 0	
	„ Balance, being Excess of Income over Expenditure for the year			164 11 8	
546 10 0				£364 11 8	

Expenditure Account

JUNE 30, 1927.

Corresponding Figures June 30, 1926.			INCOME.												
£	s.	d.			£	s.	d.	£	s.	d.					
249	0	0	By Annual Members (Including £63 10s., 1927/28)					168	10	0					
1,806	0	0	„ Annual Temporary Members (Including £357, 1927/28)					1,669	15	0					
732	0	0	„ Annual Members with Report (Including £195, 1927/28)					468	0	0					
148	15	0	„ Transferable Tickets (Including £6 5s., 1927/28)					153	15	0					
92	10	0	„ Students' Tickets (Including £15, 1927/28)					91	0	0					
			(Total Tickets issued in Advance for the Leeds Meeting, £636 15s.)												
5	0	0	„ <i>Donations</i>												
52	12	4	„ Interest on Deposits					70	3	8					
581	13	11	„ Sale of Publications					621	5	6					
167	0	3	„ Advertisement Revenue					463	6	11					
157	13	10	„ Income Tax recovered					181	13	0					
24	2	10	„ Unexpended Balance of Grants returned.					27	12	11					
			„ Liverpool Exhibitors.					3	3	4					
			„ Dividends—												
£135	0	0	Consols			£135	0	0							
86	8	0	India 3 per cent.			86	8	0							
26	9	0	Great Indian Peninsula 'B' Annuity.			26	11	6							
30	1	2	4½ per cent. Conversion Loan			30	1	2							
370	16	0	Ditto, Sir Charles Parsons' Gift.			370	16	0							
54	11	8	3½ per cent. Conversion Loan			73	8	9							
30	7	1	Local Loans			43	7	3							
58	12	6	War Stock			58	12	6							
			Ditto, Sir A. Yarrow's Gift			400	0	0							
792	5	5	792	5	5			1,224	5	2					
								4,808		£5,142		10		6	

Fund.

£	s.	d.			£	s.	d.	£	s.	d.					
			INCOME.												
			By Dividends—												
£73	11	0	India 3½ per cent.				73	11	0						
70	0	0	Canada 3½ per cent.				70	0	0						
66	13	6	London Midland and Scottish Railway Consolidated 4 per cent. Preference Stock				67	4	0						
79	7	6	Southern Railway Consolidated 5 per cent. Preference Stock				80	0	0						
289	12	0								290	15	0			
71	8	8	By Income Tax recovered							73	16	8			
185	9	4	By Balance, being Excess of Expenditure over Income for year												
								546		£364		11		8	

RESEARCH COMMITTEES, Etc.

APPOINTED BY THE GENERAL COMMITTEE, MEETING IN
LEEDS, 1927.

Grants of money, if any, from the Association for expenses connected with researches are indicated in heavy type.

SECTION A.—MATHEMATICAL AND PHYSICAL SCIENCES.

Seismological Investigations.—Prof. H. H. Turner (*Chairman*), Mr. J. J. Shaw (*Secretary*), Mr. C. Vernon Boys, Dr. J. E. Crombie, Dr. C. Davison, Sir F. W. Dyson, Sir R. T. Glazebrook, Dr. H. Jeffreys, Prof. H. Lamb, Sir J. Larmor, Prof. A. E. H. Love, Prof. H. M. Macdonald, Dr. A. Crichton Mitchell, Mr. R. D. Oldham, Prof. H. G. Plummer, Rev. J. P. Rowland, S.J., Prof. R. A. Sampson, Sir A. Schuster, Sir Napier Shaw, Sir G. T. Walker, Mr. F. J. W. Whipple. **£100** (Caird Fund grant).

Tides.—Prof. H. Lamb (*Chairman*), Dr. A. T. Doodson (*Secretary*), Dr. G. R. Goldsbrough, Dr. H. Jeffreys, Prof. J. Proudman, Prof. G. I. Taylor, Prof. D'Arcy W. Thompson, Commander H. D. Warburg.

Annual Tables of Constants and Numerical Data, chemical, physical, and technological.—Sir E. Rutherford (*Chairman*), Prof. A. W. Porter (*Secretary*), Mr. Alfred Egerton. **£5**.

Calculation of Mathematical Tables.—Prof. J. W. Nicholson (*Chairman*), Dr. J. R. Airey (*Secretary*), Mr. T. W. Chaundy, Dr. A. T. Doodson, Prof. L. N. G. Filon, Mr. R. A. Fisher, Dr. J. Henderson, and Profs. E. W. Hobson, Alfred Lodge, A. E. H. Love, and H. M. Macdonald.

Investigation of the Upper Atmosphere.—Sir Napier Shaw (*Chairman*), Mr. C. J. P. Cave (*Secretary*), Prof. S. Chapman, Mr. J. S. Dines, Mr. L. H. G. Dines, Mr. W. H. Dines, Dr. G. M. Dobson, Commr. L. G. Garbett, Sir R. T. Glazebrook, Col. E. Gold, Dr. H. Jeffreys, Dr. H. Knox-Shaw, Sir J. Larmor, Mr. R. G. K. Lempfert, Prof. F. A. Lindemann, Dr. W. Makower, Mr. J. Patterson, Sir J. E. Petavel, Dr. L. F. Richardson, Sir A. Schuster, Dr. G. C. Simpson, Sir G. T. Walker, Mr. F. J. W. Whipple, Prof. H. H. Turner. **£70**.

SECTION B.—CHEMISTRY.

Colloid Chemistry and its Industrial Applications.—Prof. F. G. Donnan (*Chairman*), Dr. W. Clayton (*Secretary*), Mr. E. Hatzsehek, Prof. W. C. McC. Lewis, Dr. E. K. Rideal.

Absorption Spectra and Chemical Constitution of Organic Compounds.—Prof. I. M. Heilbron (*Chairman*), Prof. E. C. C. Baly (*Secretary*), Prof. A. W. Stewart. **£10**.

The Chemistry of Vitamins.—Sir F. G. Hopkins (*Chairman*), Prof. J. C. Drummond (*Secretary*), Prof. G. Barger, Prof. A. Harden, Sir J. C. Irvine, Prof. J. W. McBain, Prof. Lash Miller, Dr. S. Zilva.

SECTION C.—GEOLOGY.

The Old Red Sandstone Rocks of Kiltorcan, Ireland.—Mr. W. B. Wright (*Chairman*), Prof. T. Johnson (*Secretary*), Dr. W. A. Bell, Dr. J. W. Evans, Prof. W. H. Lang, Sir A. Smith Woodward. **£10**.

To excavate Critical Sections in the Palæozoic Rocks of England and Wales.—Prof. W. W. Watts (*Chairman*), Prof. W. G. Fearnside (*Secretary*), Mr. W. S. Bisat, Prof. W. S. Boulton, Mr. E. S. Cobbold, Mr. E. E. L. Dixon, Dr. Gertrude Elles, Prof. E. J. Garwood, Prof. H. L. Hawkins, Prof. V. C. Illing, Prof. O. T. Jones, Prof. J. E. Marr, Dr. T. F. Sibly, Dr. W. K. Spencer, Dr. A. E. Trueman. **£30**.

- The Collection, Preservation, and Systematic Registration of Photographs of Geological Interest.—Prof. E. J. Garwood (*Chairman*), Prof. S. H. Reynolds (*Secretary*), Mr. C. V. Crook, Mr. A. S. Reid, Prof. W. W. Watts, Mr. R. Welch.
- To investigate the Quaternary Peats of the British Isles.—Prof. P. F. Kendall (*Chairman*), Mr. L. H. Tonks (*Secretary*), Prof. P. G. H. Boswell, Miss Chandler, Prof. H. J. Fleure, Dr. E. Greenly, Prof. J. W. Gregory, Prof. G. Hickling, Mr. J. de W. Hinch, Mr. R. Lloyd Praeger, Mrs. Reid, Dr. K. S. Sandford, Mr. T. Sheppard, Mr. J. W. Stather, Mr. A. W. Stelfox, Mr. C. B. Travis, Dr. A. E. Trueman, Mr. W. B. Wright. **£90.**
- To investigate Critical Sections in the Tertiary Rocks of the London Area. To tabulate and preserve records of new excavations in that area.—Prof. W. T. Gordon (*Chairman*), Dr. S. W. Wooldridge (*Secretary*), Miss M. C. Crosfield, Prof. H. L. Hawkins, Prof. G. Hickling. **£10.**
- To consider the opening up of Critical Sections in the Mesozoic Rocks of Yorkshire.—Prof. P. F. Kendall (*Chairman*), Mr. M. Odling (*Secretary*), Prof. H. L. Hawkins, Mr. F. Petch, Dr. Spath, Mr. J. W. Stather, Mr. H. C. Versey.
- To assemble information regarding the Distribution of Cleavage in North and Central Wales.—Prof. W. G. Fearnside (*Chairman*), Prof. P. G. H. Boswell and Mr. W. H. Wilcockson (*Secretaries*), Prof. A. H. Cox, Mr. J. S. Double, Dr. Gertrude Elles, Prof. O. T. Jones, Dr. E. Greenly, Mr. W. B. R. King, Prof. W. J. Pugh, Dr. Bernard Smith, Dr. A. K. Wells, Dr. L. J. Wills.

SECTIONS C, D, E, K.—GEOLOGY, ZOOLOGY, GEOGRAPHY, BOTANY.

- To organize an expedition to investigate the Biology, Geology, and Geography of the Australian Great Barrier Reef.—Rt. Hon. Sir M. Nathan (*Chairman*), Prof. J. Stanley Gardiner and Mr. F. A. Potts (*Secretaries*), Sir Edgeworth David, Prof. W. T. Gordon, Prof. A. C. Seward, and Dr. Herbert H. Thomas (*from Section C*); Mr. E. Heron Allen, Dr. E. J. Allen, Prof. J. H. Ashworth, Dr. G. P. Bidder, Dr. W. T. Calman, Sir Sidney Harmer, Dr. C. M. Yonge (*from Section D*); Dr. R. N. Rudmose Brown, Sir G. Lenox Conyngham, Mr. F. Debenham, Admiral Douglas, Mr. A. R. Hinks (*from Section E*); Prof. F. E. Fritsch, Dr. Margery Knight, Prof. A. C. Seward (*from Section K*).

SECTION D.—ZOOLOGY.

- To aid competent Investigators selected by the Committee to carry on definite pieces of work at the Zoological Station at Naples.—Prof. E. S. Goodrich (*Chairman*), Prof. J. H. Ashworth (*Secretary*), Dr. G. P. Bidder, Prof. F. O. Bower, Sir W. B. Hardy, Sir S. F. Harmer, Prof. S. J. Hickson, Prof. W. C. McIntosh. **£100** (Caird Fund grant).
- Zoological Bibliography and Publication.—Prof. E. B. Poulton (*Chairman*), Dr. F. A. Bather (*Secretary*), Mr. E. Heron-Allen, Dr. W. T. Calman, Dr. P. Chalmers Mitchell, Mr. W. L. Selater. **£1.**
- To nominate competent Naturalists to perform definite pieces of work at the Marine Laboratory, Plymouth.—Prof. J. H. Ashworth (*Chairman and Secretary*), Prof. W. J. Dakin, Prof. J. Stanley Gardiner, Prof. S. J. Hickson. **£35.**
- To co-operate with other Sections interested, and with the Zoological Society, for the purpose of obtaining support for the Zoological Record.—Sir S. Harmer (*Chairman*), Dr. W. T. Calman (*Secretary*), Prof. E. S. Goodrich, Prof. D. M. S. Watson. **£50.**
- On the Influence of the Sex Physiology of the Parents on the Sex-Ratio of the Offspring.—Prof. W. J. Dakin (*Chairman*), Mrs. Bisbee (*Secretary*), Prof. Carr-Saunders, Miss E. C. Herdman. **£10.**
- To report on the Pre-Linnean Zoological Collections and Specimens still extant in Great Britain, with a view to their safe custody.—Prof. E. S. Goodrich (*Chairman*), Dr. R. T. Gunther (*Secretary*).
- To draw up recommendations for the taking and presentation of Biological Measurements, and to bring such before persons or bodies concerned.—Prof. J. S. Huxley (*Chairman*), Dr. R. A. Fisher (*Secretary*).

- Investigations on Pigment in the Insecta.—Prof. W. Garstang (*Chairman*), Dr. J. W. Heslop Harrison (*Secretary*), Prof. E. B. Poulton, Prof. A. D. Peacock. **£15.**
- Experimental investigation of the effects of Vasoligation, Cryptorchidism, Grafting, etc., on the Seminal Tubules and Interstitial Tissue of the Testes in Mammals.—Dr. F. A. E. Crew (*Chairman*), Mr. J. T. Cunningham (*Secretary*), Prof. J. S. Huxley. **£10.**
- To consider the position of Animal Biology in the School Curriculum and matters relating thereto.—Prof. R. D. Laurie (*Chairman and Secretary*), Mr. H. W. Ballance, Dr. Kathleen E. Carpenter, Prof. W. J. Dakin, Mr. O. H. Latter, Prof. E. W. MacBride, Miss M. McNicol, Miss A. J. Prothero.

SECTION E.—GEOGRAPHY.

- To consider the advisability of making a Provisional Population Map of the British Isles, and to make recommendations as to the method of construction and reproduction.—Mr. H. O. Becket (*Chairman*), Mr. J. Cossar (*Secretary*), Mr. J. Bartholomew, Mr. F. Debenham, Dr. C. B. Fawcett, Prof. H. J. Fleure, Mr. R. H. Kinvig, Mr. A. G. Ogilvie, Prof. O. H. T. Rishbeth, Prof. P. M. Roxby, Lt.-Col. H. S. L. Winterbotham. **£25.**
- To inquire into the present state of Geographical Knowledge of Tropical Africa, and to make recommendations for furtherance and development.—Sir Charles Lucas (*Chairman*), Mr. A. G. Ogilvie (*Secretary*), Mr. W. H. Barker, Mr. J. McFarlane, Prof. P. M. Roxby. **£10.**

SECTIONS E, L.—GEOGRAPHY, EDUCATION.

- To formulate suggestions for a Syllabus for the Teaching of Geography both to Matriculation Standard and in Advanced Courses; to report upon the present position of the geographical training of teachers, and to make recommendations thereon; and to report, as occasion arises, to Council through the Organising Committee of Section E, upon the practical working of Regulations issued by the Board of Education (including Scotland) affecting the position of Geography in Training Colleges and Secondary Schools.—Prof. T. P. Nunn (*Chairman*), Mr. W. H. Barker (*Secretary*), Mr. L. Brooks, Prof. H. J. Fleure, Mr. O. J. R. Howarth, Mr. J. McFarlane, Sir H. J. Mackinder, Prof. J. L. Myres, Dr. Marion Newbigin, Mr. A. G. Ogilvie, Mr. A. Stevens, and Prof. J. F. Unstead (*from Section E*); Mr. D. Berridge, Mr. C. E. Browne, Sir R. Gregory, Mr. E. R. Thomas, Miss O. Wright (*from Section L*). **£3.**

SECTION F.—ECONOMIC SCIENCE AND STATISTICS.

- To investigate certain aspects of Taxation in relation to the Distribution of Wealth.—Sir Josiah Stamp (*Chairman*), Mr. R. B. Forrester (*Secretary*), Prof. E. Cannan, Prof. H. Clay, Mr. W. H. Coates, Miss L. Grier, Prof. H. M. Hallsworth, Prof. J. G. Smith, Mr. J. Wedgwood, Sir A. Yarrow. **£20.**

SECTION G.—ENGINEERING.

- Earth Pressures.—Mr. Wentworth Shields (*Chairman*), Dr. J. S. Owens (*Secretary*), Prof. G. Cook, Mr. T. E. N. Fargher, Prof. F. C. Lea, Mr. R. V. Southwell, Dr. R. E. Stradling, Dr. W. N. Thomas, Mr. E. G. Walker, Mr. J. S. Wilson. **£10.**
- Electrical Terms and Definitions.—Prof. Sir J. B. Henderson (*Chairman*), Prof. F. G. Baily and Prof. G. W. O. Howe (*Secretaries*), Prof. W. Cramp, Dr. W. H. Eccles, Prof. C. L. Fortescue, Prof. E. W. Marchant, Dr. F. E. Smith, Prof. L. R. Wilberforce, with Dr. A. Russell and Mr. C. C. Wharton.

SECTION H.—ANTHROPOLOGY.

- To report on the Distribution of Bronze Age Implements.—Prof. J. L. Myres (*Chairman*), Mr. H. J. E. Peake (*Secretary*), Mr. A. Leslie Armstrong, Mr. H. Balfour, Prof. T. H. Bryce, Mr. L. H. Dudley Buxton, Mr. O. G. S. Crawford, Prof. H. J. Fleure, Dr. Cyril Fox, Mr. G. A. Garfitt. **£100.**

- To conduct Explorations with the object of ascertaining the Age of Stone Circles.—Sir C. H. Read (*Chairman*), Mr. H. Balfour (*Secretary*), Dr. G. A. Auden, Mr. O. G. S. Crawford, Dr. J. G. Garson, Sir Arthur Evans, Sir W. Boyd Dawkins, Prof. J. L. Myres, Mr. H. J. E. Peake.
- To excavate Early Sites in Macedonia.—Prof. J. L. Myres (*Chairman*), Mr. S. Casson (*Secretary*), Dr. W. L. H. Duckworth, Mr. M. Thompson. £50.
- To report on the Classification and Distribution of Rude Stone Monuments.—Mr. G. A. Garfitt (*Chairman*), Mr. E. N. Fallaize (*Secretary*), Mr. O. G. S. Crawford, Miss R. M. Fleming, Prof. H. J. Fleure, Dr. C. Fox, Mr. G. Marshall, Prof. J. L. Myres, Mr. H. J. E. Peake, Rev. Canon Quine.
- The Collection, Preservation, and Systematic Registration of Photographs of Anthropological Interest.—Mr. E. Torday (*Chairman*), Mr. E. N. Fallaize (*Secretary*), Dr. G. A. Auden, Dr. H. A. Auden, Mr. E. Heawood, Prof. J. L. Myres.
- To report on the probable sources of the supply of Copper used by the Sumerians.—Mr. H. J. E. Peake (*Chairman*), Mr. G. A. Garfitt (*Secretary*), Mr. H. Balfour, Mr. L. H. Dudley Buxton, Prof. Gordon Childe, Prof. C. H. Desch, Prof. H. J. Fleure, Prof. S. Langdon, Mr. E. Mackay, Sir Flinders Petrie, Mr. C. Leonard Woolley.
- To conduct Archæological and Ethnological Researches in Crete.—(*Chairman*), Prof. J. L. Myres (*Secretary*), Dr. W. L. H. Duckworth, Sir A. Evans, Dr. F. C. Shruballs.
- To investigate the Culture of the Peasant Population of Modern Egypt.—Prof. J. L. Myres (*Chairman*), Mr. L. H. Dudley Buxton (*Secretary*), Mr. H. Balfour, Mr. E. N. Fallaize, Capt. Hilton Simpson, Prof. H. J. Rose. £100 (contingent).
- The Investigation of a hill fort site at Llanmelin, near Caerwent.—Dr. Willoughby Gardner (*Chairman*), Dr. Cyril Fox (*Secretary*), Dr. T. Ashby, Prof. H. J. Fleure, Mr. H. J. E. Peake, Prof. H. J. Rose, Dr. R. Mortimer Wheeler.
- To co-operate with the Torquay Antiquarian Society in investigating Kent's Cavern.—Sir A. Keith (*Chairman*), Prof. J. L. Myres (*Secretary*), Dr. R. V. Favell, Mr. G. A. Garfitt, Prof. W. J. Sollas, Mr. Mark L. Sykes.
- To conduct Anthropological investigations in some Oxfordshire villages.—Mr. H. J. E. Peake (*Chairman*), Mr. L. H. Dudley Buxton (*Secretary*), Dr. Vaughan Cornish, Miss R. M. Fleming, Prof. F. G. Parsons. £15.
- To report on the present state of knowledge of the relation of early Palæolithic Implements to Glacial Deposits.—Mr. H. J. E. Peake (*Chairman*), Mr. E. N. Fallaize (*Secretary*), Mr. H. Balfour, Prof. P. G. H. Boswell, Mr. M. Burkitt, Prof. P. F. Kendall, Prof. J. E. Marr.
- To co-operate with a Committee of the Royal Anthropological Institute in the exploration of Caves in the Derbyshire district.—Sir W. Boyd Dawkins (*Chairman*), Mr. G. A. Garfitt (*Secretary*), Mr. A. Leslie Armstrong, Prof. P. G. H. Boswell, Mr. M. Burkitt, Mr. E. N. Fallaize, Dr. R. V. Favell, Prof. H. J. Fleure, Miss D. A. E. Garrod, Dr. A. C. Haddon, Mr. Wilfrid Jackson, Dr. L. S. Palmer, Prof. F. G. Parsons, Mr. H. J. E. Peake. £50.
- To investigate processes of Growth in Children, with a view to discovering Differences due to Race and Sex, and further to study Racial Differences in Women.—Sir A. Keith (*Chairman*), Prof. H. J. Fleure (*Secretary*), Mr. L. H. Dudley Buxton, Dr. A. Low, Prof. F. G. Parsons, Dr. F. C. Shruballs.
- To report on proposals for an Anthropological and Archæological Bibliography, with power to co-operate with other bodies.—Dr. A. C. Haddon (*Chairman*), Mr. E. N. Fallaize (*Secretary*), Dr. T. Ashby, Mr. W. H. Barker, Mr. O. G. S. Crawford, Prof. H. J. Fleure, Prof. J. L. Myres, Mr. H. J. E. Peake, Dr. D. Randall-MacIver, Mr. T. Sheppard.
- To report on the progress of Anthropological Teaching in the present century.—Dr. A. C. Haddon (*Chairman*), Prof. J. L. Myres (*Secretary*), Prof. H. J. Fleure, Dr. R. R. Marett, Prof. C. G. Seligman.
- To investigate certain Physical Characters and the Family Histories of Triplet Children.—Dr. F. C. Shruballs (*Chairman*), Dr. R. A. Fisher (*Secretary*), Miss R. M. Fleming, Dr. A. Low.

- To conduct explorations on Early Neolithic Sites in Holderness.—Mr. H. J. E. Peake (*Chairman*), Mr. A. Leslie Armstrong (*Secretary*), Mr. M. Burkitt, Dr. R. V. Favell, Mr. G. A. Garfitt, Mr. Wilfrid Jackson, Prof. H. Ormerod, Dr. L. S. Palmer.
- To investigate the antiquity and cultural relations of the Ancient Copper Workings in the Katanga and Northern Rhodesia.—Mr. H. J. E. Peake (*Chairman*), Mr. E. N. Fallaize and Mr. G. A. Wainwright (*Secretaries*), Mr. H. Balfour, Mr. G. A. Garfitt, Dr. Randall-MacIver.
- To arrange for the publication of a new edition of 'Notes and Queries on Anthropology.'—Dr. A. C. Haddon (*Chairman*), Mr. E. N. Fallaize (*Secretary*), Mrs. Robert Aitken, Mr. H. Balfour, Capt. T. A. Joyce, Prof. J. L. Myres, Mrs. Seligman, Prof. C. G. Seligman.
- To consider the lines of Investigation which might be undertaken in Archæological and Anthropological Research in South Africa prior to and in view of the meeting of the Association in that Dominion in 1929.—Sir H. Miers (*Chairman*), Dr. D. Randall-MacIver (*Secretary*), Mr. H. Balfour, Dr. A. C. Haddon, Prof. J. L. Myres.
- To co-operate with Dr. Klercker's archæological laboratory in Scania in research.—Mr. H. J. E. Peake (*Chairman*), Mr. A. Leslie Armstrong (*Secretary*), Prof. H. J. Fleure, Prof. J. L. Myres, Mr. E. K. Tratman.

SECTION I.—PHYSIOLOGY.

- The Investigation of the Medullary Centres.—Prof. C. Lovatt Evans (*Chairman*), Dr. J. M. Duncan Scott (*Secretary*), Dr. H. H. Dale. **£17.**
- Colour Vision, with particular reference to the classification of Colour-blindness.—Sir C. S. Sherrington (*Chairman*), Prof. H. F. Roaf (*Secretary*), Prof. E. N. da C. Andrade, Dr. Mary Collins, Dr. F. W. Edridge-Green, Prof. H. Hartridge.
- Ductless Glands, with particular reference to the effect of autacoid activities on vasomotor reflexes.—Prof. J. Mellanby (*Chairman*), Prof. Swale Vincent (*Secretary*), Prof. B. A. McSwiney. **£30.**

SECTION J.—PSYCHOLOGY.

- Vocational Tests.—Dr. C. S. Myers (*Chairman*), Dr. G. H. Miles (*Secretary*), Prof. C. Burt, Mr. F. M. Earle, Dr. Ll. Wynn Jones, Prof. T. H. Pear, Prof. C. Spearman. **£14.**
- The place of Psychology in the Medical Curriculum.—Dr. W. Brown (*Chairman*), Dr. R. D. Gillespie (*Secretary*), Dr. C. H. Bond, Prof. E. P. Cathcart, Dr. H. Devine, Dr. J. A. Hadfield, Dr. Bernard Hart, Dr. D. K. Henderson, Dr. J. R. Lord, Dr. C. S. Myers, Prof. T. H. Pear, Prof. G. M. Robertson, Dr. T. A. Ross.

SECTION K.—BOTANY.

- The effect of Ultra-violet Light on Plants.—Prof. W. Neilsen Jones (*Chairman*), Dr. E. M. Delf (*Secretary*), Prof. V. H. Blackman. **£60.**
- To consider further the advisability of instituting a Diploma in Biology for Students in Training Colleges.—Prof. F. O. Bower (*Chairman*), Dr. Ethel N. M. Thomas (*Secretary*), Prof. R. D. Laurie, Prof. S. Mangham, Miss A. Moodie, Mr. J. L. Sager, Miss E. H. Stevenson, Prof. J. Lloyd Williams.
- To assist in the Publication by Mr. W. B. Turrill of 'The Phytogeography of the Balkan Peninsula.'—Prof. A. G. Tansley (*Chairman*), Mr. W. B. Turrill (*Secretary*), Dr. A. B. Rendle, Dr. E. J. Salisbury. **£50.**
- The Chemical Analysis of Upland Bog Waters.—Prof. J. H. Priestley (*Chairman*), Mr. A. Malins Smith (*Secretary*), Dr. B. M. Griffiths, Dr. E. K. Rideal. **£25.**
- The Status of a series of naturally occurring British Rose-hybrids.—Prof. J. W. Heslop Harrison (*Chairman*), Dr. Kathleen B. Blackburn (*Secretary*), Miss A. J. Davey. **£10.**

To co-operate with other bodies in furthering the Preservation of Rare Plants in Britain.—Dr. A. W. Hill (*Chairman*), Dr. H. Hamshaw Thomas (*Secretary*), Dr. G. Claridge Druce, Mr. W. O. Howarth, Dr. E. J. Salisbury, Prof. A. G. Tansley, Dr. T. W. Woodhead.

Transplant Experiments.—Dr. A. W. Hill (*Chairman*), Mr. W. B. Turrill (*Secretary*), Prof. F. W. Oliver, Dr. E. J. Salisbury, Prof. A. G. Tansley. £25.

SECTION L.—EDUCATIONAL SCIENCE.

To consider the Educational Training of Boys and Girls in Secondary Schools for overseas life.—Sir J. Russell (*Chairman*), Mr. C. E. Browne (*Secretary*), Major A. G. Church, Mr. H. W. Cousins, Dr. J. Vargas Eyre, Mr. G. H. Garrad, Rev. Dr. H. B. Gray, Sir R. A. Gregory, Mr. O. H. Latter, Miss E. H. McLean, Miss Rita Oldham, Mr. G. W. Olive, Miss Gladys Pott, Mr. A. A. Somerville, Dr. G. K. Sutherland, Mrs. Gordon Wilson. £10.

The bearing on School Work of recent views on formal training.—Dr. C. W. Kimmins (*Chairman*), Mr. H. E. M. Icely (*Secretary*), Prof. R. L. Archer, Prof. Cyril Burt, Prof. F. A. Cavenagh, Miss E. R. Conway, Sir Richard Gregory, Prof. G. Thomson.

Science in School Certificate Examinations: To enquire into the nature and scope of the science syllabuses prescribed or accepted by examining authorities in England for the First and Second School Certificate Examinations, and to make recommendations relating to them; particularly in regard to their relation to Matriculation and other University Entrance Examinations and their suitability as essential subjects of instruction in a rightly balanced scheme of education designed to create an intelligent interest in the realm of nature and in scientific aspects of everyday life.—Sir Richard Gregory (*Chairman*), Mr. H. W. Cousins and Mr. G. D. Dunkerley (*Secretaries*), Mr. C. E. Browne, Mr. D. Berridge, Dr. Lilian Clarke, Mr. G. F. Daniell, Dr. J. Wickham Murray, Dr. T. P. Nunn, Prof. A. Smithells, Mr. E. R. Thomas, Dr. H. W. T. Wager, Mrs. U. Gordon Wilson. £10.

CORRESPONDING SOCIETIES.

Corresponding Societies Committee.—The President of the Association (*Chairman ex-officio*), Mr. T. Sheppard (*Vice-Chairman*), the General Secretaries, the General Treasurer, Dr. F. A. Bather, Sir Richard Gregory, Sir David Prain, Sir John Russell, Mr. Mark L. Sykes, Dr. C. Tierney; with authority to co-opt representatives of Scientific Societies in the locality of the Annual Meeting.

RESOLUTIONS & RECOMMENDATIONS.

THE following Resolutions and Recommendations were referred to the Council by the General Committee at Oxford for consideration, and, if desirable, for action (except where specified as approved for action):—

From Section A.

The Committee of Section A reaffirms its recommendation of last year with reference to the collection of the Mathematical Tables published by the Association and their republication in collected form, but adds also its opinion that it would be highly desirable to include in the volume other tables at present published individually in various journals. It is recommended that the selection of the tables be left to the Committee dealing with Mathematical Tables.

From Section E.

The Sectional Committee strongly recommends the Council to urge upon the Ordnance Survey the desirability of the early preparation and publication of the survey of the St. Kilda group of islands now practically completed. (Supplemented by Sections C, D, H, K.)

From Section E.

The Sectional Committee recommends to Council that the attention of the Scottish Board of Education be drawn to the Report of the Committee on Geography Teaching with a view to the improvement, if possible, of the status of geography in Scottish schools.

From Section E.

In the opinion of the Sectional Committee, it is desirable that a Committee of the British Association be formed for the study of coral reefs in the Pacific.

The Committee therefore supports the recommendation of Section D relative to the Australian Great Barrier Reef Expedition (1928) and hopes that work of a geographical character may be included in the expedition's programme.

From Section H.

That the Council be authorised to expend an amount of the Association's funds as may be requisite upon such investigations in South African archæology as may seem desirable in view of the South African meeting.

From Section H.

That the Council be authorised to publish a new edition of 'Notes and Queries in Anthropology,' the cost being defrayed from the proceeds of the sales of the last edition which have been or will be received from the Treasurer of the Royal Anthropological Institute, together with such further sums from the Association's funds as may be required.

From Section K.

It is requested that Section K be granted permission to adopt a similar organisation to that of Section A, and to form a separate department to be devoted to the discussion of forestry subjects. (Approved for action.)

From Section K.

That the low percentage of productive forest area in Britain is a matter of grave concern, and in the national interest it is urged that afforestation and reforestation should be largely expedited. It is further urged that encouragement and financial support should be given to the development of silvicultural research and education, as well as to the Empire Forestry Association and other societies participating in the advance of the industry.

From the Conference of Delegates of Corresponding Societies.

Preservation of British wild flowers and plants:—

1. That it is desirable that information should be obtained as to the number of Local Government areas in the United Kingdom and the Irish Free State in which by-laws relating to the destruction of wild flowers and plants at present exist; as to the terms of such by-laws; and as to the prosecutions which have taken place thereunder.

2. That it is desirable to approach educational and other public bodies with a view to securing their co-operation in the protection of wild flowers and forest or woodland trees from fire or other damage.



THE PRESIDENTIAL ADDRESS.

DARWIN'S THEORY OF MAN'S DESCENT AS IT STANDS TO-DAY.

BY

PROF. SIR ARTHUR KEITH, M.D., D.Sc., LL.D., F.R.S.,
PRESIDENT OF THE ASSOCIATION.

MY LORD MAYOR, MR. VICE-CHANCELLOR, LADIES AND GENTLEMEN,

My first duty as your President, and it is a very pleasant one, is to send the following message in your name to H.R.H. The Prince of Wales :—

YOUR ROYAL HIGHNESS,

The British Association for the Advancement of Science, now assembled in Leeds to begin another session, cannot allow your year of office to terminate without offering to you sincere and humble congratulations on the happy results which have attended your Presidency. A year ago, in the historic city of Oxford, you did British Science the signal honour of coming among us as our President ; the meeting you then inaugurated set a standard which future gatherings will strive to emulate. The inspiring message you then addressed to us, and through us to men of science in every part of the Empire, has already borne fruit. We are within sight of a closer union, for which the Association itself has always striven, between men of science overseas and their colleagues at home, in their endeavour to solve problems of Imperial concern. It is too soon as yet to assess the value of the harvest of science planted under your ægis, for the best vintages of science mature slowly, but of this we are certain : the interest Your Royal Highness has taken in the work of this Association will prove a permanent source of encouragement for all who work for the betterment of life through increase of knowledge. To-night we proudly add your Presidential banner to those of the great men of science who have presided over this Association since its inception at York ninety-six years ago.

In olden times men kept their calendars by naming each year according to its outstanding event. I have no doubt that in future times the historian of this Association, when he comes to distinguish the Presidential year which opened so auspiciously in Oxford twelve months ago, will be moved to revert to this ancient custom and name it the PRINCE'S YEAR. And I am under no misapprehension as to what will happen when our historian comes to the term which I have now the honour of inaugurating at Leeds; he will immediately relapse to the normal system of numerical notation. Nor will our historian fail to note, should he be moved to contrast the Meeting at Oxford with that which now begins at Leeds, that some mischievous sprite seems to have tampered with the affairs of this Association. For how otherwise could he explain the fortune which fell to ancient Oxford, the home of History? To her lot fell a brilliant discourse on the application of science to the betterment of human lives, while Leeds, a city whose life's blood depends on the successful application of Science to Industry, had to endure, as best she could, a discourse on a theme of ancient history. For the subject of my address is Man's remote history. Fifty-six years have come and gone since Charles Darwin wrote a history of Man's Descent. How does his work stand the test of time? This is the question I propose to discuss with you to-night in the brief hour at my disposal.

In tracing the course of events which led up to our present conception of Man's origin, no place could serve as a historical starting-point so well as Leeds. In this city was fired the first verbal shot of that long and bitter strife which ended in the overthrow of those who defended the Biblical account of Man's creation and in a victory for Darwin. On September 24, 1858—sixty-nine years ago—the British Association assembled in this city just as we do to-night; Sir Richard Owen, the first anatomist of his age, stood where I now stand. He had prepared a long address, four times the length of the one I propose to read, and surveyed, as he was well qualified to do, the whole realm of Science; but only those parts which concern Man's origin require our attention now. He cited evidence which suggested a much earlier date for the appearance of man on earth than was sanctioned by Biblical records, but poured scorn on the idea that man was merely a transmuted ape. He declared to the assembled Association that the differences between man and ape were so great that it was necessary, in his opinion, to assign mankind to an altogether separate Order in the

**The Opening
Shot in the
Darwinian
Battle.**

Animal Kingdom. As this statement fell from the President's lips there was at least one man in the audience whose spirit of opposition was roused—Thomas Henry Huxley—Owen's young and rising antagonist.

I have picked out Huxley from the audience because it is necessary, for the development of my theme, that we should give him our attention for a moment. We know what Huxley's feelings were towards Owen and Huxley. Owen at the date of the Leeds Meeting. Six months before, he had told his sister that 'an internecine feud rages between Owen and myself,' and on the eve of his departure for Leeds he wrote to Hooker: 'The interesting question arises: shall I have a row with the great O. there?' I am glad to say the Leeds Meeting passed off amicably, but it settled in Huxley's mind what the 'row' was to be about when it came. It was to concern Man's rightful position in the scale of living things.

Two years later, in 1860, when this Association met in Oxford, Owen gave Huxley the opportunity he desired. In the course of a discussion Owen repeated the statement made at Leeds as to Man's separate position, claiming that the human brain had certain structural features never seen in the brain of anthropoid apes. Huxley's reply was a brief and emphatic denial with a promise to produce evidence in due course—which was faithfully kept. This opening passage at arms between our protagonists was followed two days later by that spectacular fight—the most memorable in the history of our Association—in which the Bishop of Oxford, the representative of Owen and of Orthodoxy, left his scalp in Huxley's hands. To make his victory decisive and abiding, Huxley published, early in 1863, 'The Evidences of Man's Place in Nature,' a book which has a very direct bearing on the subject of my discourse. It settled for all time that Man's rightful position is among the Primates, and that as we anatomists weigh evidence, his nearest living kin are the anthropoid apes.

My aim is to make clear to you the foundations on which rest our present-day conception of Man's origin. The address delivered by my predecessor from this chair at the Leeds Meeting of 1858 has given me the opportunity of placing Huxley's fundamental conception of Man's nature in a historical setting. I must now turn to another issue which Sir Richard Owen merely touched upon but which is of supreme interest to us now. He spent the summer in London, just as I have done, writing his address for Leeds and keeping an eye on what was happening at scientific meetings. In his case some-

**Owen's
Opinion of
Darwinism.**

**Man's
Position in
the Animal
Kingdom.**

thing really interesting happened. Sir Charles Lyell and Sir Joseph Hooker left with the Linnean Society what appeared to be an ordinary roll of manuscript, but what in reality was a parcel charged with high explosives, prepared by two very innocent-looking men—Alfred Russel Wallace and Charles Darwin. As a matter of honesty it must be admitted that these two men were well aware of the deadly nature of its contents, and knew that if an explosion occurred, Man himself, the crown of creation, could not escape its destructive effects. Owen examined the contents of the parcel and came to the conclusion that they were not dangerous; at least, he manifested no sign of alarm in his Presidential Address. He dismissed both Wallace and Darwin, particularly Darwin, in the briefest of paragraphs, at the same time citing passages from his own work to prove that the conception of Natural Selection as an evolutionary force was one which he had already recognised.

As I address these words to you I cannot help marvelling over the difference between our outlook to-day and that of the audience which Sir

The Transformation of our Outlook on Man's Origin. Richard Owen had to face in this city sixty-nine years ago. The vast assemblage which confronted him was convinced, almost without a dissentient, that Man had appeared on earth by a special act of creation; whereas the audience which I have now the honour of addressing, and that larger congregation which the wonders of wireless bring within the reach of my voice, if not convinced Darwinists are yet prepared to believe, when full proofs are forthcoming, that Man began his career as a humble primate animal, and has reached his present estate by the action and reaction of biological forces which have been and are ever at work within his body and brain.

This transformation of outlook on Man's origin is one of the marvels of the nineteenth century, and to see how it was effected we must turn our attention for a little while to the village of Downe, in the **Darwin's Generalship.** Kentish uplands, and note what Charles Darwin was doing on the very day that Sir Richard Owen was delivering his address here in Leeds. He sat in his study struggling with the first chapter of a new book; but no one foresaw, Owen least of all, that the publication of the completed book, *The Origin of Species*, fifteen months later (1859), was to effect a sweeping revolution in our way of looking at living things and to initiate a new period in human thought—the Darwinian Period—in which we still are. Without knowing it, Darwin was a consummate general. He did not launch his first campaign until he had spent twenty-two

years in stocking his arsenal with ample stores of tested and assorted fact. Having won territory with *The Origin of Species*, he immediately set to work to consolidate his gains by the publication in 1868 of another book, *The Variation of Animals and Plants under Domestication*—a great and valuable treasury of biological observation. Having thus established an advanced base, he moved forwards on his final objective—the problem of Human Beginnings—by the publication of *The Descent of Man* (1871), and that citadel capitulated to him. To make victory doubly certain he issued in the following year—1872—*The Expression of the Emotions in Man and Animals*. Many a soldier of truth had attempted this citadel before Darwin's day, but they failed because they had neither his generalship nor his artillery.

Will Darwin's victory endure for all time? Before attempting to answer this question, let us look at what kind of book *The Descent of Man*

**History as
written
by Darwin.**

is. It is a book of history—the history of Man, written in a new way—the way discovered by Charles Darwin. Permit me to illustrate the Darwinian way of writing history. If

a history of the modern bicycle had to be written in the orthodox way, then we should search dated records until every stage was found which linked the two-wheeled hobby-horse, bestrode by tall-hatted fashionable men at the beginning of the nineteenth century, to the modern 'jeopardy' which now flashes past us in country lanes. But suppose there were no dated records—only a jumble of antiquated machines stored in the cellar of a museum. We should, in this case, have to adopt Darwin's way of writing history. By an exact and systematic comparison of one machine with another we could infer the relationship of one to another and tell the order of their appearance, but as to the date at which each type appeared and the length of time it remained in fashion, we could say very little. It was by adopting this circumstantial method that Darwin succeeded in writing the history of Man. He gathered historical documents from the body and behaviour of Man and compared them with observations made on the body and behaviour of every animal which showed the least resemblance to Man. He studied all that was known in his day of Man's embryological history and noted resemblances and differences in the corresponding histories of other animals. He took into consideration the manner in which the living tissues of Man react to disease, to drugs, and to environment; he had to account for the existence of diverse races of mankind. By a logical analysis of his facts Darwin reconstructed and wrote a history of Man.

Fifty-six years have come and gone since that history was written ; an enormous body of new evidence has poured in upon us. We are now able to fill in many pages which Darwin had perforce to leave blank, and we have found it necessary to alter details in his narrative, but the fundamentals of Darwin's outline of Man's History remain unshaken. Nay, so strong has his position become that I am convinced that it never can be shaken.

**Darwin's
Position has
become
Impregnable.**

Why do I say so confidently that Darwin's position has become impregnable ? It is because of what has happened since his death in

**The Evidence
of Fossil
Remains.**

1882. Since then we have succeeded in tracing Man by means of his fossil remains and by his stone implements backwards in time to the very beginning of that period of the earth's history to which the name Pleistocene is given. We thus reach a point in history which is distant from us at least 200,000 years, perhaps three times that amount. Nay, we have gone farther, and traced him into the older and longer period which preceded the Pleistocene—the Pliocene. It was in strata laid down by a stream in Java during the latter part of the Pliocene period that Dr. Eugene Dubois found, ten years after Darwin's death, the fossil remains of that remarkable representative of primitive humanity to which he gave the name *Pithecanthropus*, or Ape-man ; from Pliocene deposits of East Anglia Mr. Reid Moir has recovered rude stone implements. If Darwin was right, then as we trace Man backwards in the scale of time he should become more bestial in form—nearer to the ape. That is what we have found. But if we regard *Pithecanthropus* with his small and simple yet human brain as a fair representative of the men of the Pliocene period, then evolution must have proceeded at an unexpectedly rapid rate to culminate to-day in the higher races of Mankind.

The evidence of Man's evolution from an ape-like being, obtained from a study of fossil remains, is definite and irrefutable, but the process has been infinitely more complex than was suspected in

**Man's
Descent has
not been in a
straight line.**

Darwin's time. Our older and discarded conception of Man's transformation was depicted in that well-known diagram which showed a single file of skeletons, the gibbon at one end and Man at the other. In our original simplicity we expected, as we traced Man backwards in time, that we should encounter a graded series of fossil forms—a series which would carry him in a straight line towards an anthropoid ancestor. We should never have made this initial mistake if we had

remembered that the guide to the world of the past is the world of the present. In our time Man is represented not by one but by many and diverse races—black, brown, yellow, and white; some of these are rapidly expanding, others are as rapidly disappearing. Our searches have shown that in remote times the world was peopled, sparsely it is true, with races showing even a greater diversity than those of to-day, and that already the same process of replacement was at work. To unravel Man's pedigree, we have to thread our way, not along the links of a chain, but through the meshes of a complicated network.

We made another mistake. Seeing that in our search for Man's ancestry we expected to reach an age when the beings we should have to deal with would be simian rather than human, we ought to have marked the conditions which prevail amongst living anthropoid apes. We ought to have been prepared to find, as we approached a distant point in the geological horizon, that the forms encountered would be as widely different as are the gorilla, chimpanzee and orang, and confined, as these great anthropoids now are, to limited parts of the earth's surface. That is what we are now realising; as we go backwards in time we discover that mankind becomes broken up, not into separate races as in the world of to-day, but into numerous and separate species. When we go into a still more remote past they become so unlike that we have to regard them not as belonging to separate species but different genera. It is amongst this welter of extinct fossil forms which strew the ancient world that we have to trace the zigzag line of Man's descent. Do you wonder we sometimes falter and follow false clues?

We committed a still further blunder when we set out on the search for Man's ancestry: indeed, some of us are still making it. We expected that Man's evolution would pursue not only an orderly file of stages but that every part of his body—skull, brain, jaws, teeth, skin, body, arms, and legs—would at each stage become a little less ape-like, a little more Man-like. Our searches have shown us that Man's evolution has not proceeded in this orderly manner. In some extinct races, while one part of the body has moved forwards another part has lagged behind. Let me illustrate this point because it is important. We now know that, as Darwin sat in his study at Downe, there lay hidden at Piltown, in Sussex, not thirty miles distant from him, sealed up in a bed of gravel, a fossil human skull and jaw. In 1912, thirty years after Darwin's

**The Diversity
of Form
in Ancient
Times.**

**Discordant
Evolution.**

death, Mr. Charles Dawson discovered this skull and my friend Sir Arthur Smith Woodward described it, and rightly recognised that skull and jaw were parts of the same individual, and that this individual had lived, as was determined by geological and other evidence, in the opening phase of the Pleistocene period. We may confidently presume that this individual was representative of the people who inhabited England at this remote date. The skull, although deeply mineralised and thick-walled, might well have been the rude forerunner of a modern skull, but the lower jaw was so ape-like that some experts denied that it went with the human fossil skull at all, and supposed it to be the lower jaw of some extinct kind of chimpanzee. This mistake would never have been made if those concerned had studied the comparative anatomy of anthropoid apes. Such a study would have prepared them to meet with the discordances of evolution. The same irregularity in the progression of parts is evident in the anatomy of *Pithecanthropus*, the oldest and most primitive form of humanity so far discovered. The thigh-bone might easily be that of modern man, the skull-cap that of an ape, but the brain within that cap, as we now know, had passed well beyond an anthropoid status. If merely a lower jaw had been found at Piltown an ancient Englishman would have been wrongly labelled 'Higher anthropoid ape'; if only the thigh-bone of *Pithecanthropus* had come to light in Java, then an ancient Javanese, almost deserving the title of anthropoid, would have passed muster as a man.

Such examples illustrate the difficulties and dangers which beset the task of unravelling Man's ancestry. There are other difficulties; there

**Blanks still
remain in the
Geological
Record.** still remain great blanks in the geological record of Man's evolution. As our search proceeds these blanks will be filled in, but in the meantime let us note their nature and their extent. By the discovery of fossil remains we have followed

Man backwards to the close of the Pliocene—a period which endured at least for a quarter of a million years, but we have not yet succeeded in tracing him through this period. It is true that we have found fossil teeth in Pliocene deposits which may be those of an ape-like man or of a man-like ape; until we find other parts of their bodies we cannot decide. When we pass into the still older Miocene period—one which was certainly twice as long as the Pliocene—we are in the heyday of anthropoid history. Thanks to the labours of Dr. Guy E. Pilgrim, of the Indian Geological Survey, we know already of a dozen different kinds of

great anthropoids which lived in Himalayan jungles during middle and later Miocene times; we know of at least three other kinds of great anthropoids which lived in the contemporary jungles of Europe. Unfortunately we have found as yet only the most resistant parts of their bodies—teeth and fragments of jaw. Do some of these fragments represent a human ancestor? We cannot decide until a lucky chance brings to light a limb-bone or a piece of skull, but no one can compare the teeth of these Miocene anthropoids with those of primitive man, as has been done so thoroughly by Prof. William K. Gregory, and escape the conviction that in the dentitions of the extinct anthropoids of the Miocene jungles we have the ancestral forms of human teeth.

It is useless to go to strata still older than the Miocene in search of Man's emergence; in such strata we have found only fossil traces of emerging anthropoids. All the evidence now at our disposal supports the conclusion that Man has arisen, as Lamarck and Darwin suspected, from an anthropoid ape not higher in the zoological scale than a chimpanzee, and that the date at which human and anthropoid lines of descent began to diverge lies near the beginning of the Miocene period. On our modest scale of reckoning, that gives Man the respectable antiquity of about one million years.

Our geological search, which I have summarised all too briefly, has not produced so far the final and conclusive evidence of Man's anthropoid origin; we have not found as yet the human *imago* emerging from its anthropoid encasement. Why, then, do modern anthropologists share the conviction that there has been an anthropoid stage in our ancestry? They are no more blind than you are to the degree of difference which separates Man and ape in structure, in appearance and in behaviour. I must touch on the sources of this conviction only in a passing manner. Early in the present century Prof. G. H. F. Nuttall, of Cambridge University, discovered a trustworthy and exact method of determining the affinity of one species of animal to another by comparing the reactions of their blood. He found that the blood of Man and that of the great anthropoid apes gave almost the same reaction. Bacteriologists find that the living anthropoid body possesses almost the same susceptibilities to infections, and manifests the same reactions, as does the body of Man. So alike are the brains of Man and anthropoid in their structural organisation that surgeons and physiologists transfer experimental observations from the one to the other. When the human

embryo establishes itself in the womb it throws out structures of a most complex nature to effect a connection with the maternal body. We now know that exactly the same elaborate processes occur in the anthropoid womb and in no other. We find the same vestigial structures—the same ‘evolutionary post-marks’—in the bodies of Man and anthropoid. The anthropoid mother fondles, nurses and suckles her young in the human manner. This is but a tithe of the striking and intimate points in which Man resembles the anthropoid ape. In what other way can such a myriad of coincidences be explained except by presuming a common ancestry for both ?

The crucial chapters in Darwin’s *Descent of Man* are those in which he seeks to give a historical account of the rise of Man’s brain and of the varied functions which that organ subserves. How do these chapters stand to-day ? Darwin was not a professional anatomist and therefore accepted Huxley’s statement that there was no structure in the human brain that was not already present in that of the anthropoid. In Huxley’s opinion the human brain was but a richly annotated edition of the simpler and older anthropoid book, and that this edition, in turn, was but the expanded issue of the still older original primate publication. Since this statement was made thousands of anatomists and physiologists have studied and compared the brain of Man and ape ; only a few months ago Prof. G. Elliot Smith summarised the result of this intensive enquiry as follows : ‘ No structure found in the brain of an ape is lacking in the human brain, and, on the other hand, the human brain reveals no formation of *any sort* that is not present in the brain of the gorilla or chimpanzee. . . . The only distinctive feature of the human brain is a quantitative one.’ The difference is only quantitative but its importance cannot be exaggerated. In the anthropoid brain are to be recognised all those parts which have become so enormous in the human brain. It is the expansion of just those parts which have given Man his powers of feeling, understanding, acting, speaking and learning.

Darwin himself approached this problem not as an anatomist but as a psychologist, and after many years of painstaking and exact observation, succeeded in convincing himself that, immeasurable as are the differences between the mentality of Man and ape, they are of degree, not of kind. Prolonged researches made by modern psychologists have but verified and extended Darwin’s conclusions. No matter

what line of evidence we select to follow—evidence gathered by anatomists, by embryologists, by physiologists, or by psychologists—we reach the conviction that Man's brain has been evolved from that of an anthropoid ape and that in the process no new structure has been introduced and no new or strange faculty interpolated.

In these days our knowledge of the elaborate architecture and delicate machinery of the human brain makes rapid progress, but I should be misled if I suggested that finality is in sight. Far from it; our enquiries are but begun. There is so much we do not yet understand. Will the day ever come when we can explain why the brain of man has made such great progress while that of his cousin the gorilla has fallen so far behind? Can we explain why inherited ability falls to one family and not to another, or why, in the matter of cerebral endowment, one race of mankind has fared so much better than another? We have as yet no explanation to offer, but an observation made twenty years ago by one on whom Nature has showered great gifts—a former President of this Association and the doyen of British zoologists—Sir E. Ray Lankester—deserves quotation in this connection: 'The leading feature in the development and separation of Man from other animals is undoubtedly the relative enormous size of the brain in Man and the corresponding increase in its activities and capacity. It is a striking fact that it was not in the ancestors of Man alone that this increase in the size of the brain took place at this same period—the Miocene. Other great mammals of the early Tertiary period were in the same case.' When primates made their first appearance in geological records, they were, one and all, small-brained. We have to recognise that the tendency to increase of brain, which culminated in the production of the human organ, was not confined to Man's ancestry but appeared in diverse branches of the Mammalian stock at a corresponding period of the earth's history.

I have spoken of Darwin as a historian. To describe events and to give the order of their occurrence is the easier part of a historian's task; his real difficulties begin when he seeks to interpret the happenings of history, to detect the causes which produced them, and explain why one event follows as a direct sequel to another. Up to this point we have been considering only the materials for Man's history, and placing them, so far as our scanty information allows, in the order of their sequence, but now we have to seek out the

**Darwin's
Conception
of Evolution
illustrated.**

biological processes and controlling influences which have shaped the evolutionary histories of Man and ape. The evolution of new types of Man or of ape is one thing, and the evolution of new types of motor cars is another, yet for the purposes of clear thinking it will repay us to use the one example to illustrate the other. In the evolution of motor vehicles Darwin's law of Selection has prevailed; there has been severe competition and the types which have answered best to the needs and tastes of the public have survived. The public has selected on two grounds—first for utility, thus illustrating Darwin's law of Natural Selection, and secondly because of appearance's sake; for, as most people know, a new car has to satisfy not only the utilitarian demands of its prospective master but also the æsthetic tastes of its prospective mistress, therein illustrating Darwin's second law—the law of Sexual Selection. That selection, both utilitarian and æsthetic, is producing an effect on modern races of mankind and in surviving kinds of ape, as Darwin supposed, cannot well be questioned. In recent centuries the inter-racial competition amongst men for the arable lands of the world is keener than in any known period of human history.

The public has selected its favoured types of car, but it has had no direct hand in designing and producing modifications and improvements which have appeared year after year. To understand how **The Production of New Types.** such modifications are produced the enquirer must enter a factory and not only watch artisans shaping and fitting parts together but also visit the designer's office. In this way an enquirer will obtain a glimpse of the machinery concerned in the evolution of motor cars. If we are to understand the machinery which underlies the evolution of Man and of ape, we have to enter the 'factories' where they are produced—look within the womb and see the ovum being transformed into an embryo, the embryo into a foetus, and the foetus into a babe. After birth we may note infancy passing into childhood, childhood into adolescence, adolescence into maturity, and maturity into old age. Merely to register the stages of change is not enough; to understand the controlling machinery we have to search out and uncover the processes which are at work within developing and growing things and the influences which co-ordinate and control all the processes of development and of growth. When we have discovered the machinery of development and of growth we shall also know the machinery of Evolution, for they are the same.

If the simile I have used would sound strange in Darwin's ear, could he hear it, the underlying meaning would be familiar to him. Over and over again he declared that he did not know how 'variations' were produced, favourable or otherwise; nor could he have known, for in his time hormones were undreamt of and experimental embryology scarcely born. With these recent discoveries new vistas opened up for students of Evolution. The moment we begin to work out the simile I have used and compare the evolutionary machinery in a motor factory with that which regulates the development of an embryo within the womb, we realise how different the two processes are. Let us imagine for a moment what changes would be necessary were we to introduce 'embryological processes' into a car factory. We have to conceive a workshop teeming with clustering swarms of microscopic artisans, mere specks of living matter. In one end of this factory we find swarms busy with cylinders, and as we pass along we note that every part of a car is in process of manufacture, each part being the business of a particular brigade of microscopic workmen. There is no apprenticeship in this factory, every employee is born, just as a hive-bee is, with his skill already fully developed. No plans or patterns are supplied; every workman has the needed design in his head from birth. There is neither manager, overseer, nor foreman to direct and co-ordinate the activities of the vast artisan armies. And yet if parts are to fit when assembled, if pinions are to mesh and engines run smoothly, there must be some method of co-ordination. It has to be a method plastic enough to permit difficulties to be overcome when such are encountered and to permit the introduction of advantageous modifications when these are needed. A modern works manager would be hard put to were he asked to devise an automatic system of control for such a factory, yet it is just such a system that we are now obtaining glimpses of in the living workshops of Nature.

I have employed a crude simile to give the lay mind an inkling of what happens in that 'factory' where the most complicated of machines are forged—the human body and brain. The fertilised ovum divides and redivides; one brood of microscopic living units succeeds another, and as each is produced the units group themselves to form the 'parts' of an embryo. Each 'part' is a living society; the embryo is a huge congeries of interdependent societies. How are their respective needs regulated, their freedoms

**Machine and
Animal
Evolution
contrasted.**

**The
Machinery of
Development.**

protected, and their manœuvres timed? Experimental embryologists have begun to explore and discover the machinery of regulation. We know enough to realise that it will take many generations of investigators to work over the great and new field which is thus opening up. When this is done we shall be in a better position to discuss the cause of 'variation' and the machinery of Evolution.

If we know only a little concerning the system of government which prevails in the developing embryo we can claim that the system which **The Machinery of Growth** prevails in the growing body, as it passes from infancy to maturity, is becoming better known to us every year. The influence of the sex glands on the growth of the body has been known since ancient times; their removal in youth leads to a transformation in the growth of every part of the body, altering at the same time the reactions and temperament of the brain. In more recent years medical men have observed that characteristic alterations in the appearance and constitution of the human body can be produced by the action of other glands—the pituitary, thyroid, parathyroid, and adrenals. Under the disorderly action of one or other of these glands individuals may, in the course of a few years, take on so changed an appearance that the differences between them and their fellows become as great as, or even greater than, those which separate one race of mankind from another. The physical characters which are thus altered are just those which mark one race off from another. How such effects are produced we did not know until 1904, when the late Prof. E. H. Starling, a leader amongst the great physiologists of our time, laid bare an ancient and fundamental law in the living animal body—his law of hormones. I have pictured the body of a growing child as an immense society made up of myriads of microscopic living units, ever increasing in numbers. One of the ways—probably the oldest and most important way—in which the activities of the communities of the body are co-ordinated and regulated is by the postal system discovered by Starling, wherein the missives are hormones—chemical substances in ultra-microscopic amounts, despatched from one community to another in the circulating blood. Clearly the discovery of this ancient and intricate system opens up fresh vistas to the student of Man's evolution. How Darwin would have welcomed this discovery! It would have given him a rational explanation to so many of his unsolved puzzles, including that of 'correlated variations.' Nor can I in this connection forbear to mention the name of one who presided so ably over the affairs of this

Association fifteen years ago—Sir E. Sharpey-Schafer. He was the pioneer who opened up this field of investigation and has done more than anyone to place our knowledge of the nature and action of the glands of internal secretion on a precise basis of experimental observation. With such sources of knowledge being ever extended and others of great importance, such as the study of Heredity, which have been left unmentioned, we are justified in the hope that Man will be able in due time not only to write his own history but to explain how and why events took the course they did.

In a brief hour I have attempted to answer a question of momentous importance to all of us—What is Man's origin? Was Darwin right when he said that Man, under the action of biological forces which can be observed and measured, has been raised from a place amongst anthropoid apes to that which he now occupies? The answer is Yes! and in returning this verdict I speak but as foreman of the jury—a jury which has been empanelled from men who have devoted a lifetime to weighing the evidence. To the best of my ability I have avoided, in laying before you the evidence on which our verdict was found, the rôle of special pleader, being content to follow Darwin's own example—Let the Truth speak for itself.

THE OUTSTANDING PROBLEMS OF RELATIVITY.

ADDRESS BY

PROF. E. T. WHITTAKER, LL.D., Sc.D., F.R.S.,
PRESIDENT OF THE SECTION.

It was in January 1914 that Einstein¹ made his great departure from the Newtonian doctrine of gravitation by abandoning the idea that the gravitational potential is scalar. The thirteen eventful years which have passed since then have seen the rapid development of the new theory, which is called General Relativity, and the confirmation by astronomers and astrophysicists of its predictions regarding the bending of light-rays by the sun and the displacement of spectral lines. At the same time a number of new problems have arisen in connection with it; and perhaps the time has now come to review the whole situation and to indicate where there is need for further investigation.

Speaking from this Chair I may perhaps be permitted to recall that my first experience of the British Association was as one of the secretaries of Section A nearly thirty years ago; and that my secretarial duties brought me the privilege of an introduction to the distinguished mathematical physicist, Prof. G. F. FitzGerald of Dublin, who was a regular and prominent member of the section until his death in 1901. FitzGerald had long held an opinion which he expressed in 1894 in the words 'Gravity is probably due to a change of structure of the æther, produced by the presence of matter.'² Perhaps this is the best description of Einstein's theory that can be given in a single sentence in the language of the older physics: at any rate it indicates the three salient principles, firstly, that gravity is not a force acting at a distance, but an effect due to the modification of space (or, as FitzGerald would say, of the æther) in the immediate neighbourhood of the body acted on; secondly, that this modification is propagated from point to point of space, being ultimately connected in a definite way with the presence of material bodies; and thirdly, that the modification is not necessarily of a scalar character. The mention of the æther would be criticised by many people to-day as something out of date and explicable only by the circumstance that FitzGerald was writing thirty-three years ago; but even this criticism will not be universal; for Wiechert and his followers have actually combined the old æther theory with ideas resembling Einstein's by the hypothesis that gravitational potential is an expression of what we may call the specific inductive capacity and permeability of the æther, these qualities being

¹ *Zeits. f. Math. u. Phys.* 63 (1914), p. 215.

² FitzGerald's *Scientific Writings*, p. 313.

affected by the presence of gravitating bodies. Assuming that matter is electrical in its nature, it is inferred that matter will be attracted to places of greater dielectric constant. It seems possible that something of this sort was what FitzGerald had in mind.

Let us now consider some of the consequences of Einstein's theory. One of the first of them is that when a planet moves round a central attracting body in a nearly circular orbit, the perihelion of the orbit advances by (approximately) $6\pi v^2/c^2$ in each revolution, where v is the planet's velocity and c is the velocity of light. This gives for the motion of the perihelion of Mercury almost exactly the amount ($42''$ per century) which is found from observation. Another consequence is that light-rays which pass near a massive body are deflected, the bending at the sun's limb being $1''.75$. This was confirmed observationally by the British expeditions to the eclipse of May 1919, and still more decisively by the Lick Observatory expedition to the Australian eclipse of September 1922: the Lick observers found for the shift $1''.72 \pm 0''.11$, which differs from Einstein's predicted value by much less than its estimated probable error. Yet another result of general relativity is that, by the Principle of Equivalence, light which reaches us from a place of different gravitational potential (such as the sun) must exhibit a kind of Doppler effect. This 'gravitational shift of the solar spectral lines' is now generally admitted to be confirmed by comparisons of wave-lengths at the centre of the sun's disc with wave-lengths from the arc *in vacuo*; and in 1925 the effect was observed, on a much larger scale, by W. S. Adams in the spectrum of the companion of Sirius.

Besides the effects which have been verified observationally there are many consequences of Einstein's theory which are of interest as opening up new fields or presenting new inter-relations of phenomena in astronomy and physics. For instance, there is a contribution to the precession of the equinoxes which, unlike ordinary precession, does not depend on the oblateness of the earth. Again, the bending of the rays of light near a gravitating body, which has been observed in the case of the sun and the companion of Sirius, may, theoretically at any rate, be so pronounced that the ray is permanently captured by the attracting body, and describes for ever a track round and round it, which approaches spirally and asymptotically to a circle whose centre is at the centre of gravitation. Yet another deduction is that an electrified body, or a single electron, which is at rest in a varying gravitational field, must emit radiation. Indeed, now that a definite connection has been set up between electricity and gravitation, the whole of electromagnetic theory must be rewritten.

As a further illustration of the (as yet) unexplored possibilities of the new physics, let us consider the well-known equations for the potential of Newtonian gravitation, namely Laplace's equation

$$\frac{\delta^2 V}{\delta x^2} + \frac{\delta^2 V}{\delta y^2} + \frac{\delta^2 V}{\delta z^2} = 0$$

in space where there is no matter, and Poisson's equation

$$\frac{\delta^2 V}{\delta x^2} + \frac{\delta^2 V}{\delta y^2} + \frac{\delta^2 V}{\delta z^2} = -4\pi\rho$$

in space where matter of density ρ is present. In general relativity, when the field is statical, these are replaced by an equation

$$\Delta_2 V = \frac{1}{2}v \left(\sum_{i,k=1}^3 a^{ik} T_{ik} + \frac{T_{00}}{N^2} \right)$$

where $\Delta_2 V$ is the Beltrami's second differential parameter for the form $ds^2 = \sum a_{ik} dx_i dx_k$ which specifies the line-element in the three-dimensional space, T_{ik} is the energy-tensor, and N is the velocity of light at the point. This equation reduces to Laplace's equation in one extreme case (when no matter or energy is present at the point) and to Poisson's equation in another extreme case (when the energy is entirely in the form of ordinary matter), but it offers an infinite variety of possibilities intermediate between the two, in which energy is present but not in the form of ordinary matter. It is possible that this equation, which evidently suggests an approach to the new wave-mechanics, may play as important a part in the microphysics and astrophysics of the future as the equations of Laplace and Poisson have played in the ordinary physics of the past.

Let us take another consequence of the new theory. Consider the field due to a single gravitating particle. Take any plane through the particle, and in this plane draw the family of concentric circles, whose centre is at the particle. The length of the circumference of these circles will, of course, diminish as we take circles nearer to the centre: and at one place we shall have a circle whose circumference is of length

$$4\pi\beta M/c^2$$

where β is the Newtonian constant of attraction, M is the mass of the particle in grams, and c is the velocity of light in empty space. When we arrive at this circle we find that the element of length directed radially towards the centre is infinite: that is to say, the space within the circle is impenetrable. Every gravitating particle has a ring-fence around it, within which no other body can approach.

It will be noticed that in all that I have said I have used the ordinary language of three-dimensional physical space, and have avoided mention of that four-dimensional world of space-time which looms so largely in most expositions of relativity. The reason is that I have been speaking only of phenomena belonging to the statical class, *i.e.* those for which the field does not vary with the time: and for such phenomena, as Levi-Civita showed in a famous paper on the *Rendiconti dei Lincei* of 1917, the four-dimensional problem can be reduced to a three-dimensional one of the same kind as physicists have been accustomed to deal with. It may be consoling to those who distrust their own powers of doing research in four dimensions to know that in general relativity there are enough important unsolved problems of the statical type, for which capacity in three dimensions is sufficient, to keep all the investigators of the world busy for at least another generation.

It is interesting to see how these new three-dimensional problems differ from those of the older Physics. Taking as an example a small

particle moving in a statical field in general relativity, we find that the motion is determined by Lagrangian differential equations

$$\frac{d}{dt} \left(\frac{\delta L}{\delta \dot{x}_r} \right) - \frac{\delta L}{\delta x_r} = 0 \quad (r = 1, 2, 3)$$

just as in the classical dynamics : but L is not now a simple difference of terms of the 'kinetic energy' and 'potential energy' types. It shows the sound instinct of the creators of the old dynamics that they almost always studied the equations without making the assumption that L consists of terms of kinetic and potential type : and thus their discoveries remain perfectly valid in the dynamics of general relativity.

The fundamental researches of Einstein and Hilbert, with the discovery of the field equations of gravitation, were published in 1915. At that time German scientific journals did not reach this country regularly, and British physicists and mathematicians were mostly occupied in one way or another with duties arising out of the Great War ; so that comparatively little notice was taken of the new theory on this side of the North Sea during the first year or two of its existence, and indeed it was not until the end of the War that most of us had any opportunity of studying it. In Germany, however, it was quickly realised that general relativity was one of the most profound and far-reaching contributions that had ever been made to science. Its successful prediction of new phenomena of a most unexpected kind was an event of the first importance, but still more significant was its complete subversion of the foundations of physics and reconstruction of the whole subject on a new basis. From time immemorial the physicist and the pure mathematician had worked on a certain agreement as to the shares which they were respectively to take in the study of nature. The mathematician was to come first and analyse the properties of space and time, building up the primary science of geometry ; then, when the stage had thus been prepared, the physicist was to come along with the dramatis personæ—material bodies, magnets, electric charges, light, and so forth—and the play was to begin. But in Einstein's revolutionary conception, the characters created the stage as they walked about on it : geometry was no longer antecedent to physics, but indissolubly fused with it into a single discipline. The properties of space, in general relativity, depend on the material bodies that are present ; Euclidean geometry is deposed from its old position of priority, and from acceptance as a valid representation of space ; indeed its whole spirit is declared to be alien to that of modern physics, for it attempts to set up relations between points which are at a finite distance apart, and thus is essentially an action-at-a-distance theory ; and in the new world no direct relations exist at all except between elements that are contiguous to each other.

The scheme of general relativity, as put forward by Einstein in 1915, met with some criticism as regards the unsatisfactory position occupied in it by electrical phenomena. While gravitation was completely fused with metric, so that the notion of a mechanical force on ponderable bodies due to gravitational attraction was completely abolished, the notion of a mechanical force acting on electrified or magnetised bodies placed in an electric or magnetic field still persisted as in the old physics. This seemed

to be an imperfection, and it was felt that sooner or later everything, including electro-magnetism, would be re-interpreted and represented in some way as consequences of the pure geometry of space and time. In 1918 Weyl proposed to effect this by rebuilding geometry once more on a new foundation, which we must now examine.

Weyl fixed attention in the first place on the 'light-cone,' or aggregate of directions issuing from a world-point P, in which light-signals can go out from it. The light-cone separates those world-points which can be affected by happenings at P, from those points whose happenings can affect P; it, so to speak, separates past from future, and therefore lies at the basis of physics. Now the light-cone is represented by the equation $ds^2=0$, where ds is the element of proper time, and Weyl argued that this equation, rather than the quantity ds^2 itself, must be taken as the starting-point of the subject; in other words, it is the *ratios* of the ten coefficients g_{pq} in ds^2 , and not the *actual values* of these coefficients, which are to be taken as determined by our most fundamental physical experiences. Following up this principle, he devised a geometry more general than the Riemannian geometry which had been adopted by Einstein: instead of being specified, like the Riemannian geometry, by a single quadratic differential form

$$\sum_{p,q} g_{pq} dx_p dx_q$$

it is specified by a quadratic differential form

$$\sum_{p,q} g_{pq} dx_p dx_q$$

and a linear differential form $\sum_p \varphi_p dx_p$ together. The coefficients g_{pq} of the quadratic form can be interpreted, as in Einstein's theory, as the potentials of gravitation, while the four coefficients φ_p of the linear form can be interpreted as the scalar-potential and the three components of the vector-potential in Maxwell's electromagnetic theory. Thus Weyl succeeded in exhibiting both gravitation and electricity as effects of the metric of the world.

The enlargement of geometrical ideas thus achieved was soon followed by still wider extensions of the same character, due to Eddington, Schouten, Wirtinger, and others. From the point of view of the geometer, they constituted striking and valuable advances in his subject, and they seemed to offer an attractive prospect to the physicist of combining the whole of our knowledge of the material universe into a single unified theory. The working out of the various possible alternative schemes for identifying these more general geometries with physics has been the chief occupation of relativists during the last nine years. Many ingenious proposals and adaptations have been published, and more than one author has triumphantly announced that at last the problem has been solved. But I do not think that any of the theories can be regarded as satisfactory, and within the last year or two a note of doubt has been perceptible; were we after all on the right track? At last Einstein himself³ has made

³ *Math Ann.* 97 (1926), p. 99.

up his mind and renounced the whole movement. The present position, then, is that the years 1918-1926 have been spent chiefly in researches which, while they have contributed greatly to the progress of geometry, have been on altogether wrong lines so far as physics is concerned, and we have now to go back to the pre-1918 position and make a fresh start, with the definite conviction that the geometry of space-time is Riemannian.

Granting then this fundamental understanding, we have now to inquire into the axiomatics of the theory. This part of the subject has received less attention in our country than elsewhere, perhaps because of the more or less accidental circumstance that the most prominent and distinguished exponents of relativity in England happened to be men whose work lay in the field of physics and astronomy rather than in mathematics, and who were not specially interested in questions of logic and rigour. It is, however, evidently of the highest importance that we should know exactly what assumptions must be made in order to deduce our equations, especially since the subject is still in a rather fluid condition, and there is a possibility of effecting some substantial improvement in it by a partial reconstruction of the foundations.

What we want to do, then, is to set forth the axiomatics of general relativity in the same form as we have been accustomed to give to the axiomatics of any other kind of geometry—that is, to enunciate the primitive or undefined concepts, then the definitions, the axioms, and the existence-theorems, and lastly the deductions. In the course of the work we must prove that the axioms are compatible with each other, and that no one of them is superfluous.

The usual way of introducing relativity is to talk about measuring-rods and clocks. This is, I think, a very natural and proper way of introducing the doctrine known as 'special relativity,' which grew out of FitzGerald's hypothesis of the contraction of moving bodies, and was first clearly stated by Poincaré in 1904, and further developed by Einstein in 1905. But general relativity, which came ten years later, is a very different theory. In general relativity there are no such things as rigid bodies—that is, bodies for which the mutual distance of every pair of particles remains unaltered when the body moves in the gravitational field. That being so, it seems desirable to avoid everything akin to a rigid body—such, for example, as measuring-rods or clocks—when we are laying down the axioms of the subject. The axioms should obviously deal only with the simplest constituents of the universe. Now if one of my clocks or watches goes wrong, I do not venture to try to mend it myself, but take it to a professional clockmaker, and even he is not always wholly successful, which seems to me to indicate that a clock is not one of the simplest constituents of the universe. Some of the expounders of relativity have recognised the existence of this difficulty, and have tried to turn it by giving up the ordinary material clock with its elaborate mechanism, and putting forward in its place what they call an atomic clock; by which they mean a single atom in a gas, emitting light of definite frequency. Unfortunately the atom is apparently quite as complicated in its working as a material clock, perhaps more so, and is less understood; and the statement that the frequency is the same under all conditions, whatever is happening to the atom, is (whether true or not)

a highly complex assumption which could scarcely be used in an axiomatic treatment of the subject until it has been dissected into a considerable number of elementary axioms, some of them perhaps of a disputable character.

It seems to me that we should abandon measuring-rods and accurate clocks altogether, and begin with something more primitive. Let us then take any system of reference for events—a network of points to each of which three numbers are assigned—which can serve as spatial co-ordinates, and a number indicating the succession of events at each point to serve as a temporal co-ordinate. Let us now refer to this co-ordinate system, the paths which are traced by infinitesimal particles moving freely in the gravitational field. Then it is one of the fundamental assumptions of the theory that these paths are the geodesics belonging to a certain quadratic differential form

$$\sum_{p,q} g_{pq} dx_p dx_q.$$

The truth or falsity of this assumption may, in theory at any rate, be tested by observation, since if the paths are geodesics they must satisfy certain purely geometrical conditions, and whether they do or not is a question to be settled by experience.

Granting for the present that the paths do satisfy these conditions, let us inquire if a knowledge of the paths or geodesics is sufficient to enable us to determine the quadratic form. The answer to this is in the negative, as may easily be seen if we consider for a moment the non-Euclidean geometry defined by a Cayley-Klein metric in three-dimensional space. In the Cayley-Klein geometry the geodesics are the straight lines of the space; but a knowledge of this fact is not sufficient to determine the metric, since the Absolute may be any arbitrary quadric surface.

In order to determine the quadratic form in general relativity we must then be furnished with some information besides the knowledge of the paths of material particles. It is sufficient, as Levi-Civita has remarked, that we should be given the null geodesics, *i.e.* the geodesics along which the quadratic form vanishes. In the Cayley-Klein geometry these are the tangents to the Absolute; in general relativity they are simply the tracks of rays of light.

So from our knowledge of the paths of material particles and the tracks of rays of light we can construct the quadratic form

$$\sum_{p,q} g_{pq} dx_p dx_q$$

and then we are ready for the next great axiom, namely Einstein's Principle of Covariance, that 'the laws of nature must be represented by equations which are covariantive for the quadratic form

$$\sum_{p,q} g_{pq} dx_p dx_q$$

with respect to all point-transformations of co-ordinates.'

The theory is now fairly launched and I need not describe its axiomatic development further. The point I wish specially to make is that in the

above treatment there has been no mention either of length or of time : neither measuring-rod nor clock has been introduced in any way. We have left open the question whether the quadratic form does or does not represent anything which can be given directly by measuring-rods and clocks. For my own part I incline to think that the notions of length of material bodies, and time of clocks, are really rather complex notions which do not normally occur in the early chapters of axiomatic physics. The results of the ether-drift experiments of D. C. Miller at Mount Wilson in 1925, if confirmed, would seem to indicate that the geometry which is based on rigid measuring-rods is actually different from the geometry which is based on geodesics and light-rays.

The actual laws of nature are most naturally derived, it seems to me, from the Minimum Principle enunciated in 1915 by Hilbert, that 'all physical happenings (gravitational, electrical, &c.) in the Universe are determined by a scalar world-function \mathfrak{S} being, in fact, such as to annul the variation of the integral

$$\iiint \mathfrak{S} dx_0 dx_1 dx_2 dx_3.'$$

This principle is the grand culmination of the movement begun 2000 years ago by Hero of Alexandria with his discovery that reflected light meets the mirror at a point such that the total path between the source of light and the eye is the shortest possible. In the seventeenth century Hero's theorem was generalised by Fermat into his 'Principle of Least Time' that 'Nature always acts by the shortest course,' which suffices for the solution of all problems in geometrical optics. A hundred years later this was further extended by Maupertuis, Euler, and Lagrange, into a general principle of 'Least Action' of dynamical systems, and in 1834 Hamilton formulated his famous Principle which was found to be capable of reducing all the known laws of nature—gravitational, dynamical, and electrical—to a representation as minimum-problems.

Hilbert's minimum principle in general relativity is a direct application of Hamilton's principle, in which the contribution made by gravitation is the integral of the Riemann scalar curvature. Thus gravitation acts so as to make the total amount of the curvature of space-time a minimum : or as we may say, *gravitation simply represents a continual effort of the universe to straighten itself out.* This is general relativity in a single sentence.

I have already explained that the curvature of space-time at any point at any instant depends on the physical events that are taking place there : in statical systems, where we can consider space of three dimensions separately from time, the mean curvature (*i.e.* the sum of the three principal curvatures) of the space at any point is proportional to the energy-density at the point. Since, then, the curvature of space is wholly governed by physical phenomena, the suggestion presents itself that the metric of space-time may be determined *wholly* by the masses and energy present in the universe, so that space-time cannot exist at all except in so far as it is due to the existence of matter. This doctrine, which is substantially due to Mach, was adopted in 1917 by Einstein, and has led to some interesting developments. The point at issue may be illustrated

by the following concrete problem : if all matter were annihilated except one particle which is to be used as a test-body, would this particle have inertia or not ? The view of Mach and Einstein is that it would not ; and in support of this view it may be urged that, according to the deductions of general relativity, the inertia of a body is increased when it is in the neighbourhood of other large masses ; it seems needless, therefore, to postulate other sources of inertia, and simplest to suppose that *all* inertia is due to the presence of other masses. When we confront this hypothesis with the facts of observation, however, it seems clear that the masses of whose existence we know—the solar systems, stars, and nebula—are insufficient to confer on terrestrial bodies the inertia which they actually possess ; and therefore if Mach's principle were adopted, it would be necessary to postulate the existence of enormous quantities of matter in the universe which have not been detected by astronomical observation, and which are called into being simply in order to account for inertia in other bodies. This is, after all, no better than regarding some part of inertia as intrinsic.

Under the influence of Mach's doctrine, Einstein made an important modification of the field-equations of gravitation. He now objected to his original equations of 1915 on the ground that they possessed a solution even when the universe was supposed void of matter, and he added a term—the 'cosmological term' as it is called—with the idea of making such a solution impossible. After a time it was found that the new term did not do what it had been intended to do, for the modified field-equations still possessed a solution—the celebrated 'De Sitter World'—even when no matter was present ; but the De Sitter World was found to be so excellent an addition to the theory that it was adopted permanently, and with it of course the cosmological term in the field-equations ; so that this term has been retained for exactly the opposite reason to that for which it was originally introduced.

The 'De Sitter World' is simply the universe as it would be if all minor irregularities were smoothed out : just as when we say that the earth is a spheroid, we mean that the earth would be a spheroid if all mountains were levelled and valleys filled up. In the case of the De Sitter universe the levelling is a more formidable operation, since we have to smooth out the earth, the sun, and all the heavenly bodies, and reduce the world to a complete uniformity. But after all, only a very small fraction of the cosmos is occupied by material bodies ; and it is interesting to inquire what space-time as a whole is like when we simply ignore them.

The answer is, as we should expect, that it is a manifold of constant curvature. This means that it is isotropic (*i.e.* the Riemann curvature is the same for all orientations at the same point), and is also homogeneous. As a matter of fact, there is a well-known theorem that any manifold which is isotropic in this sense is necessarily also homogeneous, so that the two properties are connected. A manifold of constant curvature is a projective manifold, *i.e.* ordinary projective geometry is valid in it when we regard geodesics as straight lines ; and it is possible to move about in it any system of points, discrete or continuous, rigidly, *i.e.* so that the mutual distances are unaltered.

The simplest example of a manifold of constant curvature is the

surface of a sphere in ordinary three-dimensional Euclidean space ; and the easiest way of constructing a model of the De Sitter World is to take a pseudo-Euclidean manifold of five dimensions in which the line-element is specified by the equation

$$-ds^2 = dx^2 + dy^2 + dz^2 - du^2 + dv^2$$

and in this manifold to consider the four-dimensional pseudosphere whose equation is

$$x^2 + y^2 + z^2 - u^2 + v^2 = R^2.$$

The pseudospherical world thus defined has a constant Riemannian measure of curvature $-1/R^2$.

The De Sitter World may be regarded from a slightly different standpoint as having a Cayley-Klein metric, governed by an Absolute whose equation in four-dimensional homogeneous co-ordinates is

$$x^2 + y^2 + z^2 - u^2 + v^2 = 0$$

where u is time. Hyperplanes which do not intersect the Absolute are spatial, so spatial measurements are elliptic, *i.e.* the three-dimensional world of space has the same kind of geometry as the surface of a sphere, differing from it only in being three-dimensional instead of two-dimensional. In such a geometry there is a natural unit of length, namely the length of the complete straight line, just as on the surface of a sphere there is a natural unit of length, namely the length of a complete great circle.

We are thus brought to the question of the dimensions of the universe : what is the length of the complete straight line, the circuit of all space ? The answer must be furnished by astrophysical observations, interpreted by a proposition which belongs to the theory of De Sitter's world, namely that the lines of the spectrum of a very distant star should be systematically displaced ; the amount of displacement is proportional to the ratio of the distance of the star from the observer to the constant radius of curvature R of the universe. In attempting to obtain the value of R from this formula we meet with many difficulties : the effect is entangled with the ordinary Doppler effect due to the radial velocity of the star ; it could in any case only be of appreciable magnitude with the most distant objects ; and there is the most serious difference of opinion among astronomers as to what the distance of these objects really is. Within the last twelve months the distance of the spiral nebula M 33 Trianguli has been estimated by Dr. Hubble of the Mount Wilson Observatory at 857,000 light-years, and by Dr. Perrine, the Director of the Cordoba Observatory, at only 30,000 light-years ; and there is a similar uncertainty of many thousands per cent. in regard to all other very remote objects. Under these circumstances we hesitate to assign a definite length for the radius of curvature of the universe ; but it is millions of light-years, though probably not greater than about a hundred millions. The curvature of space at any particular place due to the general curvature of the universe is therefore quite small compared to the curvature which may be imposed on it locally by the presence of energy. By a strong magnetic field we can produce a curvature with a radius of only 100 light-years, and of

course in the presence of matter the curvature is far stronger still. So the universe is like the earth, on which the local curvature of hills and valleys is far greater than the general curvature of the terrestrial globe.

In concluding these remarks I ought perhaps to apologise for having said nothing about the relation of general relativity to the new wave-mechanics. My excuse must be that, at the request of the Secretary of the British Association, this address was sent to the printer many weeks before the meeting; and the wave-mechanics is developing so rapidly that, as one eminent worker has declared, anything printed is *ipso facto* out of date.

SECTION B.—CHEMISTRY.

CO-ORDINATION COMPOUNDS.

ADDRESS BY

N. V. SIDGWICK, O.B.E., Sc.D., F.R.S.,

PRESIDENT OF THE SECTION.

WHEN the British Association last met in Leeds, thirty-seven years ago, the attention of Section B was largely devoted to the discussion of ionisation, and at a joint meeting with Section A the new theory of Arrhenius was defended by van 't Hoff and Ostwald against the attacks of such conservative die-hards as S. U. Pickering and Prof. H. E. Armstrong. That meeting may be taken as marking the recognition in this country of the distinction between ionised and non-ionised linkages. It seems appropriate therefore that I should devote this address to the discussion of a third species or sub-species of atomic linkage, that of co-ordination.

The theory of co-ordination is indeed by no means new: it is only a few years younger than that of electrolytic dissociation; but its interpretation, and especially the establishment of its relation to the older theory of structural chemistry, have only become possible through the advance made in our knowledge of atomic structure in the last few years; and there are still many points in which its bearing on questions of general chemistry is not yet fully realised.

Werner's Theory of Co-ordination, which was first put forward in 1891, the year after our last meeting at Leeds, originated in an attempt to explain the structure of certain compounds formed by apparently saturated molecules with one another. A large number of such compounds, often very stable, had been observed, but they were commonly disregarded by chemists, or were shelved under the convenient name of molecular compounds; and such attempts as had been made to formulate them on the lines of structural chemistry had been conspicuously unsuccessful. The most marked peculiarities of these compounds were three. In the first place their structure appeared to be quite independent of the ordinary rules of valency, according to which the numerical value of the valency of an atom element was primarily determined by the group in the periodic table to which it belonged, first rising and then falling by single units as we go from one group to the next. In these compounds the structure was rather determined by the tendency of four or six atoms or groups to arrange themselves round a central atom. Secondly, in these complexes, a univalent atom or group of atoms such as chlorine or NO_2 could be replaced by a whole apparently saturated molecule such as water or ammonia without affecting the stability of the complex. Thirdly, such replacement was always accompanied by a

remarkable change in the ionisation of the molecule. Thus, platonic chloride PtCl_4 combines with six molecules of ammonia forming a compound $\text{Pt}(\text{NH}_3)_6\text{Cl}_4$, in which all four chlorine atoms are ionised. As the ammonia molecules are removed one by one, the chlorine atoms appear to take their places in the non-ionised part of the molecule, until we reach $\text{Pt}(\text{NH}_3)_2\text{Cl}_4$, which is not ionised at all, and is not a salt: every replacement diminishes the positive charge on the platinum complex by one. If more ammonia molecules are replaced by chlorine atoms, the ionisation occurs again, but now the complex has acquired a negative charge, so that we finally reach the well-known 'double salt' K_2PtCl_6 .

To explain these phenomena, Werner proposed a theory of molecular structure founded on entirely new principles: that it was determined by the tendency of atoms, irrespective of the periodic groups to which they belonged, to attach to themselves a definite number (usually six, sometimes four, and less often other numbers) of other atoms or groups, which might either be univalent radicals or whole molecules capable of independent existence. These groups, together with the central atom, formed the 'co-ordination complex,' and the groups were said to occupy the 'first sphere' of combination of the central atom; the molecule might also contain other atoms or groups occupying a 'second sphere,' which were less firmly attached, and did not count as part of the co-ordination complex. For example, in the hexammine of platonic chloride $[\text{Pt}(\text{NH}_3)_6]\text{Cl}_4$, the ammonia molecules were regarded as occupying the first sphere of the platinum and satisfying its co-ordination number 6, while the chlorine atoms occupied the second sphere. Experimentally the groups in the second sphere were distinguished by the fact that they were ionised in water, while those forming part of the co-ordination complex were not. Werner produced a great mass of evidence in support of these views; the chemical public in general did not, however, pay much attention to them until in 1911 Werner was able to show that certain compounds of chromium and other elements which, on his theory, should have asymmetric molecules could actually be resolved into their optically active forms. It then became evident that the theory must at least contain a large element of truth.

Thus, some fifteen years ago, Werner had been able to demonstrate that his theory accounted for the structure of a large number of (mainly inorganic) compounds, with which the ordinary structural theory was not able to deal. He himself applied the theory to organic compounds as well: he regarded it as a general theory of molecular constitution, and sought to show that the structural theory failed even in dealing with organic compounds. But this must be admitted to be the weakest part of his argument: he was not really able to prove that the structural theory was inadequate in the sphere of its greatest triumphs, that of organic chemistry.

An impartial critic writing at this time (say, in 1913) might have summed up the position thus: The theory of structural chemistry gives a satisfactory account of the molecular constitution of nearly all organic and a certain number of inorganic compounds, but it is unable to deal with a large number of substances of the latter class. The theory of co-ordination, which proceeds on wholly different lines, is able to explain

the structure of those compounds with which the former theory breaks down: it can account for their composition, their properties, their isomerism, and even their stereoisomerism. There thus appear to be two different modes of chemical combination, each holding within its own sphere, but neither applicable to the whole of chemistry. This was obviously a most unsatisfactory position, and one which could only be temporary. It was clear that the true theory of molecular structure when it was discovered must be one which would apply to all compounds, both organic and inorganic, and that the two rival theories, that of structural chemistry and that of co-ordination, must ultimately prove to be two partial aspects of the same general phenomenon.

The final solution of the problem was scarcely to be expected until a more definite idea had been reached of the physical mechanism of atomic linkage, and this could only be attained when more was known of the structure of the atom. The discovery by Sir Joseph Thomson and others of the electron as a universal constituent of all forms of matter had suggested that it was in this that the mechanism of valency was to be sought; but a further development of our knowledge of the electronic arrangement was necessary before it could be applied in detail to answer the questions asked by the chemist. This development was reached, in the years from 1911 onwards, mainly through the work of Rutherford, Bohr, and Moseley. Through their researches we learnt that the atom consists of a positive nucleus surrounded by groups of electrons, and that each successive element in the periodic table contains one more unit of positive charge on its nucleus than the one before it, and one more planetary electron: the atomic number being at once the ordinal number of the element in the periodic table, the number of units of positive charge on the nucleus, and the number of surrounding electrons. The conceptions of the nuclear atom and of atomic number may be said to give us the empirical formula of the atom. The next stage, the determination of the structural formula, of the way in which the surrounding atoms are arranged, although it is not yet complete, has been so far developed by means of the Bohr theory and its subsequent modifications, that we are now in a position to apply the physical results to the solution of the purely chemical problems of valency and molecular structure.

It is evident that the cause of chemical combination is the striving of atoms to attain more stable arrangements of their planetary electrons by some kind of redistribution. The inert gases, since they do not enter into chemical combination, must already possess an arrangement too stable to be capable of improvement; their atomic numbers therefore give us the sizes of a series of completed or stable groups, and it may be expected that when other atoms combine to form a molecule, they thereby attain these numbers of electrons, or something like them.

The application of these ideas in detail to the explanation of valency was primarily due to Kossel and G. N. Lewis, who published their views almost simultaneously in 1916. Kossel dealt with ionised links, and showed that their structure could be explained by supposing that they were due to the migration of one or more electrons from an atom which had a few more than a stable (inert gas) number, to another which had a few less; hence the valency in ionised compounds was usually equal to

the number of places by which an element was removed from an inert gas, and was positive if it came after the inert gas, and negative if it came before. The more difficult problem of the non-ionised link, such as we find in elementary chlorine or hydrogen, or in methane, was explained by Lewis by the assumption that it is possible for two atoms, each of which is a few electrons short of a stable number, to share electrons in such a way that each counts as part of the constitution of each atom, thus forming a link which is not merely due to electrostatic attraction, and so cannot be ionised.

These views of the two fundamental kinds of linkage—ionised and non-ionised, polar and non-polar, or, as Langmuir has conveniently called them, electrovalent and covalent—that one is due to the transference and the other to the sharing of electrons between two atoms, have been confirmed by all subsequent discoveries, and may be taken to be generally accepted. The atomic models on which both Kossel and Lewis founded their theories have indeed been shown to be impossible. These authors supposed that the electrons surrounding the nucleus were at rest, and Lewis in particular assigned to them definite positions in his famous cube, which was subsequently developed in so much detail by Langmuir. We now know that any such static hypothesis is untenable; it involves the assumption of a variety of otherwise unknown forces, and it is incapable of explaining many of the properties of atoms, especially their spectra; whereas all these are accounted for by a dynamic model, in which the electrons move in orbits round the nucleus much as the planets move round the sun. But the conceptions of the transference and the sharing of electrons can equally well be applied to the dynamic model of Bohr.

So far the mechanism of valency at which we have arrived is that of structural chemistry rather than that of co-ordination. The numerical value of the valency of an atom appears equal to the excess or defect of its electrons as compared with the stable number of an inert gas. If it has, say, two electrons in excess, loosely attached and forming an imperfect group, it can lose them and become a divalent cation, or it can share them and so form two covalent links; if it has two electrons less than the stable number it can take up two from another atom or atoms and become a divalent anion, or it can share two electrons belonging to other atoms and become di-covalent; if the excess or defect is two, the valency, of whichever kind, is two also. The next element, with an excess or defect of one, will have a valency of one. We thus arrive at the relation between the valency of an element and its group in the periodic table which was originally pointed out by Mendeléeff. In fact the majority of the structural formulae of organic chemistry can be translated into electronic formulae by the simple process of writing two dots (for two shared electrons) in place of a line. It is important to notice the reason for the *two* dots—for Lewis's assumption that two shared electrons are necessary for every covalency. The most familiar property of valency, which has been recognised from the earliest times, is that if one atom combines with another it not only uses up one of its own units of combining power, but one of those of the other atom as well. Where the link is ionised, the reason of this is obvious: the electron which one atom loses must be taken up

by the other. But the same must hold with covalency also. If the covalent link consisted of a single shared electron, this would not be true. If the atom A could form a covalent link with B merely by sharing one of its own electrons with B, this would use up one of the units of B, since it would increase B's electrons by one; but it would not affect the combining power of A. For example, hydrogen (1) is one electron short of the stable helium number 2; carbon (6) is 4 short of the stable neon number 10. If in methane CH_4 each hydrogen atom is attached to the carbon by a single shared electron, then if this electron is derived from the hydrogen it will satisfy the carbon, but will leave the hydrogen still one electron short; if it is derived from the carbon, it will leave the carbon four electrons short of the stable number. In either case the resulting molecule would be unsaturated, whereas it is in fact saturated. It was to meet this difficulty that Lewis assumed that the covalent link consisted of two shared electrons, one derived from each of the two linked atoms. On this hypothesis the carbon in methane shares one of its four valency electrons with each of the four hydrogen atoms, thus increasing the number of each hydrogen to two, and at the same time each hydrogen shares its own electron with the carbon, thus satisfying the carbon.

We have therefore got an electronic mechanism which will account for the two recognised forms of valency, the ionised and the non-ionised. If these are really the only two forms of linkage which can exist in a molecule, it must be possible to extend them so as to account for co-ordination. This is in fact surprisingly simple, and the solution was foreshadowed by Lewis in his paper of 1916. It is clear that the link which attaches one of the groups of a co-ordination complex to the central atom is of the non-polar type. It is an essential point in Werner's theory that such links are not ionised; this is how they are distinguished from the links to atoms in the 'second sphere.' Thus in the compound $[\text{Pt}(\text{NH}_3)_4\text{Cl}_2]\text{Cl}_2$ the two chlorine atoms outside the bracket enclosing the co-ordination complex are ionised, while those inside are not. The same conclusion is supported by the fact that the arrangement of the groups in the co-ordination complex round the central atom can give rise to optical activity; for this, as we know from organic chemistry, is only possible with groups which are attached by covalent links, that is, by directed forces. We must therefore look for an explanation of co-ordination in the formation of covalencies, that is, of links formed of pairs of shared electrons. But they must arise in some way different from that which we have hitherto assumed, since their numerical relations are different; their number is not related to the periodic group of the central atom, and also they can be formed with atoms (such as the nitrogen in ammonia or the oxygen in water) which have already completed a stable number of electrons. Now in the normal covalency formation described above it was assumed that one of the two shared electrons of a link came from each of the two atoms concerned. It is obviously possible that both might be derived from one of them; and the recognition of this possibility is all that is required to provide an electronic mechanism for co-ordination. By means of this extension of the idea of covalency formation we can explain all the peculiarities of co-ordination compounds, of which, as we have seen, the most important are the power of further

combination shown by apparently saturated molecules such as water and ammonia, the attainment of a valency limit (the co-ordination number) independent of the periodic group to which the atom belongs, and the peculiar change of electrovalency which accompanies the replacement of a univalent radical such as chlorine by a whole molecule such as ammonia. We may consider these in turn. In nitrogen there are five valency electrons; by combination with three hydrogen atoms this number is increased to eight, giving a molecule of ammonia, in which the octet of the nitrogen is complete and the atom is so far saturated. But, though complete, the octet is not fully utilised: six of its members are shared with the three hydrogen atoms, but the other two are unshared, and so can form a fourth link if another atom can be found which will share them without sharing some of its own electrons with the nitrogen in return. This may happen in a variety of ways. A hydrogen ion, consisting of a single proton with no attendant electron, is capable of taking up two electrons, and, as we all know, if a hydrogen ion meets an ammonia molecule it combines with it to form an ammonium ion

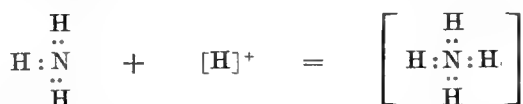

The nitrogen has now shared all its eight valency electrons, two with each of the four hydrogen atoms; but since the ammonia molecule is electrically neutral, while the hydrogen ion is positively charged, the resulting NH_4 molecule is also positively charged. Again, boron has three valency electrons; it can share one of them with each of three chlorine atoms (thus completing the octets of the chlorines), and at the same time take a share in one of the electrons belonging to each of the chlorines. This gives boron trichloride BCl_3 , in which the boron has increased its valency group from three to six. The boron cannot combine with a fourth chlorine atom, because, although its own octet is not complete, it has no more unshared valency electrons to offer for a covalent link. But if it meets an ammonia molecule it can share the unshared pair of electrons of the nitrogen, and so form a co-ordinate link:—

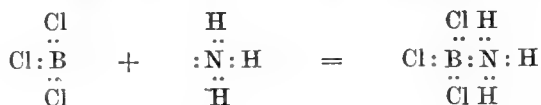

In this way each of the two atoms assumes a covalency (or, if we prefer to call it so, a co-ordination number) of four.

The conditions for the formation of a co-ordinate link thus are that we should have one atom which has a pair of unshared valency electrons to offer, and another which has room for one or more pairs of electrons in its valency group. It is convenient to have a symbol and a nomenclature to express this process, and I have therefore suggested that, while the ordinary covalent link is represented by a line A—B , the co-ordinate link should be written as an arrow $\text{A} \rightarrow \text{B}$, pointing away from the atom which contributes the two electrons of the link; also we may call the

atom which lends the electrons (A) the donor, and that which receives them (B) the acceptor.

We have now to apply these ideas to the compounds on which Werner based his theory. Any simple cation—that is, an atom stripped of its valency electrons—can act as an acceptor. It can build up a valency group by sharing electrons belonging to other atoms, that is, by forming co-ordinate links. Thus the chromic ion $[\text{Cr}]^{+++}$ contains a stable core of twenty-one electrons and has no valency group; the stability of this arrangement is proved by the stability of the chromic salts. This ion can then form a series of co-ordinate links with molecules of ammonia, by sharing the 'lone pair' of electrons of the nitrogen atom. Since the stable size of the valency group for such an ion is 12, six molecules of ammonia will be taken up, and in this way the hexammine $[\text{Cr}(\text{NH}_3)_6]\text{Cl}_3$ is produced. We have thus accounted for the power which certain complete molecules possess of combining further through co-ordination.

The next point is to explain the peculiar change of electrovalency which accompanies the replacement of an ammonia molecule by, say, a chlorine atom. It is natural that if an ammonia molecule is removed, this should be replaced by another covalently linked atom, because that is required to maintain the valency group of 12. When the ammonia is removed it takes away with it the two shared electrons which it originally contributed; the chlorine atom which replaces it supplies one electron to be shared by the chromium, but the chromium is called upon to supply the other electron for the link. Thus the chromium is one electron short of its stable number, and must take up an electron from elsewhere to make up the deficiency. In other words, the replacement of the ammonia by chlorine will reduce the positive charge on the ion by one unit, giving instead of $[\text{Cr}(\text{NH}_3)_6]^{+++}$ the ion $[\text{Cr}(\text{NH}_3)_5\text{Cl}]^{++}$, or the salt $[\text{Cr}(\text{NH}_3)_5\text{Cl}]\text{Cl}_2$. The same change will occur for every replacement of a whole molecule in the complex by a univalent radical. Thus the very peculiar change of electrovalency which Werner established is a necessary result of the electronic mechanism underlying the linkage. The third important characteristic of the co-ordination compounds is the co-ordination number itself. As we have seen, the most remarkable point about these compounds is that the relation observed in ordinary structural chemistry between the valency of an element and its group in the periodic table disappears. Instead of finding that the valency—the number of links which an atom can form—increases from one in the first group to four in the fourth, and then falls (in the simpler compounds at any rate) to one in the seventh, we find that the co-ordination number is independent of the periodic group, and is usually either six or four. But this again follows necessarily from the theory. So long as the valency is expressed by ionisation, or by normal covalencies to which each atom contributes one electron, it must be limited either by the number of electrons which the atom has to offer or by the number for which it has room in its valency group; it will therefore be determined by the distance of the atom in question from the nearest inert gas, or, in other words, by the group in the periodic table to which it belongs. In its saturated compounds the atom will usually be left either with an imperfect valency group (like the boron in boron trichloride) or with one which is incompletely shared,

like the nitrogen in ammonia. Where co-ordination occurs this limitation is removed; the atom can give or take as many electrons as may be necessary, and in the fully co-ordinated atom it will have a fully shared valency group. Its maximum co-ordination valency, or co-ordination number, is therefore half the number of electrons in its maximum valency group.

In this way the conception of the co-ordinate link as being a covalency, that is, a link of two shared electrons, differing from the ordinary covalency only in this, that the two electrons both come from one of the linked atoms instead of one from each, provides the mechanism required to explain the existence and the properties of the co-ordination compounds of Werner. This conclusion removes the apparent contradiction between organic and inorganic compounds; it refers the structure of molecules of both classes to the same physical principles, and exhibits the original co-ordination theory of Werner and the older structural theory as two aspects of the same general process. It further removes two objections which might have been urged against the co-ordination theory as it was originally proposed. The first of these is that it seemed to assign a unique position to one or two of the atoms in a molecule, which were regarded as 'co-ordination centres' in some way governing the structure of the whole. This is obviously an incorrect view of the molecule, in which every atom is in a sense as important as every other. We can now see that this is in fact the case, and that the nitrogen in an ammine, for example, is just as much a centre of co-ordination as the metal. The second point is that the distinction which Werner made between principal and subsidiary valencies, which was always unsatisfactory, now disappears. It originated in a desire to retain the valencies of the structural theory, while recognising the formation of more links than the structural theory would permit. It has long been clear that there was no ground for maintaining the existence of this distinction within the co-ordination complex. The electronic theory shows that the difference between a normal and a co-ordinate covalency is in their method of formation; when they have been formed both alike consist of two shared electrons.

The further application of these ideas to those compounds with which Werner's name is most closely connected is an inquiry of great interest, but I do not propose to pursue it here. I would rather consider some more general questions. We have been led, in seeking an explanation of the structure of co-ordination compounds, to the conception of a third form of atomic linkage in addition to the recognised forms of electrovalencies and covalencies; or, as we should rather say, we have found that a covalency can arise in a second way. This new method is peculiar in that it allows of the combination of apparently saturated atoms or molecules with one another, and it is therefore the condition which makes the association of liquids possible. Links of this type are not confined to inorganic compounds, but are widely spread in organic chemistry, as Werner himself showed. Co-ordination is thus of great importance throughout the whole of chemistry. Now that we understand the physical mechanism which underlies it, we may hope to arrive at some idea of its characteristic properties, and it will be well to consider what new light these throw on various problems of chemistry in general.

We have already seen that the formation of a co-ordinate link involves the presence of one atom which can act as a donor and another which can act as an acceptor. The donor must have a pair of unshared valency electrons. The acceptor must have fewer valency electrons than it is capable of holding. This raises the question of the maximum size of the valency group. If we maintain the original octet theory, that the valency group cannot exceed 8, and at the same time hold that every covalency involves two shared electrons, it follows that the maximum covalency cannot exceed 4. The existence of stable compounds such as sulphur hexafluoride shows that this conclusion is false, and hence that one or other of the two assumptions must be abandoned. Some chemists maintain the octet limit, and explain the existence of atoms with a covalency greater than four by assuming the possibility of a covalent link formed of a single shared electron: they suppose, for example, that in sulphur hexafluoride the sulphur has eight shared electrons, and that two of the fluorine atoms are attached by two electrons each, and the other four by one each. This view seems to me to be untenable. There must be some relation between the mechanism of a link and its behaviour; if not, it is of little use to discuss the mechanism. Links of single electrons undoubtedly occur in a limited number of compounds of hydrogen, such as $[H_2]^+$ and the hydrides of boron (B_2H_6 , &c.); but, as we should expect, they are always very unstable. I cannot believe that a substance like sulphur hexafluoride, which is one of the most stable of known compounds, and can be heated to a red heat with sodium without decomposition, can contain four such links. I should therefore abandon the limit of 8 for the valency group (as G. N. Lewis has now done), and adhere to the view that in all but a few unstable compounds every covalency involves two shared electrons. On these principles the maximum size of the valency group is twice the covalency or co-ordination maximum. An examination of the structures of known compounds gives strong reason to believe that there is a direct and simple relation between the maximum covalency (co-ordination number) of an atom and its position in the periodic table, and that this depends not on the periodic group but on the period in which it occurs, so that the co-ordination classification runs horizontally, while the normal valency values, as we all know, run vertically. It would take too long to discuss the evidence for this statement, but I may give the conclusions. The maximum covalency of hydrogen is 2: that of elements in the first short period (lithium to fluorine) is 4: that of elements in the second short period (sodium to chlorine) and the first long period (potassium to bromine) is 6: and that of the later elements is 8. The maximum number of electrons in the valency group is, of course, twice as great, being 4, 8, 12, and 16, respectively. No physical reason for these facts can as yet be given, but a certain relation can be traced between the numbers and those in the grouplets of the Bohr theory as modified by Stoner and Main Smith.

The next question is the difference in properties which is to be expected between the normal and co-ordinate covalencies. These are essentially of two kinds. In the first place the co-ordinate links are in general less stable. The stability of a link depends on the work required to break it, or, in other words, on the difference of energy content between the original

molecule and the products of the rupture of the link. Hence, the more unstable these products are, the more difficult it is to break the link. The rupture of a normal covalency leads to the production of two univalent radicals



that is, of two highly unstable products. But a co-ordinate link can break by the return of the two shared electrons to the atom to which they originally belonged



and one at least of the products is now a molecule capable of independent existence. Thus, the products of the rupture of a co-ordinate link are, as a rule, more stable than those formed by breaking a normal covalency, and the co-ordinate link is therefore less stable. This difference is particularly marked in rings containing co-ordinate links, those which Prof. Morgan has called chelate rings: these are far more sensitive to strain, owing to the weakness of the co-ordinate link, than the ordinary rings of organic chemistry; while the latter are known of every size from three to eighteen members, chelate rings almost invariably contain either six or five; a few 4-rings are known and one or two 7- and 8-rings; but none with less than four or more than eight members. This explanation of the difference in strength between normal and co-ordinate links is of considerable importance; the fact is beyond dispute, and if we are to maintain that the mechanism of both forms of linkage is the same, consisting in the sharing of two electrons, we must be able to give a reason for this difference in stability.

The second point of difference is that while the normal covalency involves no considerable disturbance of the electrostatic equilibrium in the molecule, this is not true of the co-ordinate link. In the normal link between two atoms, each atom shares one electron with the other atom. If the electrons were shared equally between the two, there would be no electrostatic disturbance at all. We do not know enough about the dynamics of the sharing of electrons to say how nearly this is true, but the properties of ordinary covalent compounds indicate that it is not far from the truth, and that the shared electron usually divides its time more or less equally between the two atoms which share it. But when a co-ordinate link is formed between two originally neutral atoms, one of them loses and the other gains a share in two electrons. Hence, the acceptor must receive a negative charge from the link and the donor a positive charge. This fact is expressed by some chemists, such as Prof.

Lowry, by writing the link $A-\overset{+}{B}$ instead of $A \rightarrow B$. A molecule containing such a link is therefore an electrical dipole. This electrostatic disturbance will have two chief results: it will increase the dielectric constant of the substance, and it will increase the attraction of the molecules for one another, and therefore diminish the volatility. That this does actually occur we have plenty of evidence; I may give a few examples, selected from non-associated substances, in order to avoid the complications which association might produce. While the value of the dielectric constant for hydrocarbons is about 2.3, for ethers about 4.

and for esters about 7 (all these being free from co-ordinate links), it is greatly increased by the introduction of a nitro-group

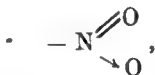

which contains this link, and is for nitromethane 39 and for nitrobenzene 36. The effect on the boiling point is seen by comparing the alkyl nitrites $\text{R}-\text{O}-\text{N}=\text{O}$ with the isomeric nitro-compounds

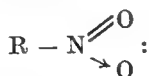

the latter boil from 50° to 100° higher than the former. Many other examples might be quoted.

These examples suggest the consideration of associated liquids. As long as we were at liberty to invent new kinds of subsidiary valencies, the existence of association caused no trouble. But now that we claim to have discovered the mechanism of atomic combination, we must identify the link between the molecules of an associated substance with one or other of the forms of link that we have recognised, and it is evident that the co-ordinate link is the form required. We ought therefore to be able to find in every associated substance a donor and an acceptor atom. Such atoms are always found to be present: in the most familiar class of associated compounds, those containing hydroxyl groups, the oxygen atom of this group, with its two pairs of unshared valency electrons, is the donor, and the hydrogen atom, being able as we have seen to increase its valency group from two to four, is the acceptor. We thus get the possibility of an indefinite degree of polymerisation:—

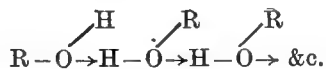

That the association does depend on the two atoms of the hydroxyl group is shown by the fact that if we replace either the oxygen by sulphur or the hydrogen by an alkyl group the association disappears: neither the mercaptans nor the ethers are associated. Associated substances possess the properties which we have seen to accompany the co-ordinate link, the high dielectric constant and the low volatility. The latter property is commonly taken to be sufficiently explained by the rise of molecular weight which the association produces, but unless this is much greater than we have any reason to suppose, it will not account for the whole effect. For example, the ethers boil about 60° lower than the corresponding thio-ethers; hydrogen sulphide boils at -61° , and so unimolecular H_2O should boil about -120° . If the real formula of water is H_6O_3 (and it is very improbable that its average polymerisation is even as great as this at 100°), its true molecular weight is not 18 but 54. This will account for a rise in the boiling point, but not for so large a rise as is actually found. Hydrogen selenide (mol. wt. 81.2) boils at -42° , and butane (mol. wt. 58) at $+1^\circ$. Evidently the polymerised molecules

themselves are much less volatile than corresponds to their molecular weights, as we should expect from the presence of the co-ordinate link. The high values of the dielectric constant (water, formamide, and hydrogen peroxide about 80, methyl alcohol 35, ethyl alcohol 27) are further evidence of co-ordination. This reference to the dielectric constant raises a point which is worth mentioning, although I cannot discuss it in detail here. In some modern developments of the theory of organic reactions great stress is laid on the dipole moment of such groups as hydroxyl. The values of these moments are calculated from the dielectric constants of the hydroxylic compounds, and are assumed to apply to the single unassociated molecules. Now since we have seen that the association itself must increase the dielectric constant owing to the co-ordination of the molecules with one another, it is by no means certain that values so obtained hold good for the unpolymerised hydroxyl group. It is, of course, quite possible that the same conditions which make the hydroxyl group so ready to polymerise also give it a high dipole moment even in the simple molecule; but the rise in the dielectric constant which the association itself must produce is a factor which must be taken into account, especially as it is one which will vary with the temperature.

This view that association is due to co-ordination throws light on the behaviour of a group of substances whose position was hitherto rather puzzling. There are many substances such as sulphur dioxide, ethers, and amines which behave in many ways like associated liquids, and yet when they are directly tested are found not to be associated; they are volatile, and give simple values of the molecular weight in the pure state and in non-associated solvents. It has long been a problem how such substances should be classified. It is now clear that they contain only one of the two elements necessary to co-ordination: they have donor atoms (oxygen or nitrogen) but no acceptor atoms (the acceptor properties of hydrogen attached to nitrogen are for some reason very weak). They are thus incapable of polymerisation, and in the presence of non-associated liquids they behave as normal non-associated substances. But in the presence of a substance capable of association, and so containing acceptor as well as donor atoms, they behave as associated substances.

These considerations emphasise a very important and far-reaching characteristic of the co-ordinate link, its one-sided nature. The two atoms taking part in it perform quite different functions; and in determining the structure of a co-ordination compound it is essential to show which of the two co-ordinated atoms is the donor and which the acceptor. This distinguishes the electronic view of co-ordination from the subsidiary valency theory of Werner and his school; there was no apparent reason why two atoms which could form subsidiary valencies with a third atom should not also form them with one another. We can see now that such a linkage is impossible: there must be the necessary opposition in character between the two atoms before co-ordination can take place. It is true that Werner himself was saved by his almost uncanny insight into molecular structure from falling into this error, but there was nothing in his theory to save him from it, and not all his followers had as true an intuition as he had himself. The recognition of this distinction, to which the electronic interpretation directly leads, is a definite advance.

Among the more important developments of the theory of co-ordination which must be expected in the near future, its systematic application to organic chemistry must take a high place, for it is by the study of organic compounds that we really can examine in minute detail the influence of structure on properties. The very existence of organic chemistry—the fact that the compounds of carbon form a group at least as numerous and important as all other chemical compounds together—can only be fully explained by reference to the theory of co-ordination. Werner pointed out long ago that the unique position of carbon was due to the fact that its valency and its co-ordination number were identical. This we should now express by saying that as it has four valency electrons it can obtain a fully shared octet by normal covalency formation and without the production of co-ordinate links. But this is not all. Since carbon is in the first short period of the table, this octet is incapable of further expansion. Hence the ordinary saturated quadrivalent carbon atom is incapable of acting either as an acceptor or as a donor, and for this reason it is peculiarly well protected from the attack of other atoms. This is undoubtedly the chief cause of the remarkable sluggishness (*Trägheit*, as Victor Meyer called it) so characteristic of carbon, a disinclination to react which gives comparative stability to a large number of thermodynamically unstable compounds. That this explanation is sound may be seen by comparing the behaviour of the halides of carbon with that of the halides of neighbouring elements. Most non-metallic halides are readily hydrolysed by water, and we may assume that the hydrolysis is preceded by a combination (through the formation of co-ordinate links) of the water with the halide. In boron trichloride, for example, the incomplete octet of the boron completes itself by sharing a pair of electrons from the oxygen of the water, forming the compound

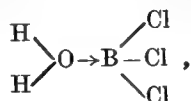

analogous to the ammonia compound discussed above. A hydrogen and a chlorine atom then separate as hydrochloric acid, leaving a hydroxyl group attached to the boron, and by the repetition of this process the hydrolysis to boric acid is completed. The same reaction occurs with silicon tetrachloride, because, although the silicon has already a complete octet, it can expand this to a group of 12, since it is in the second period. With nitrogen the position is not quite the same. In the trichloride NCl_3 the octet of the nitrogen is complete, and it is incapable of expansion; but it is not fully shared, and contains a lone pair of electrons. Hence, though it cannot be an acceptor, it can be a donor. It forms a co-ordinate link not with the oxygen but with the hydrogen of the water, giving

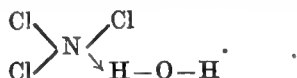

The chlorine then reacts with the hydroxyl, forming hypochlorous acid, while the hydrogen remains attached to the nitrogen the ultimate product

being ammonia. The truth of this hypothesis of intermediate co-ordination with the water is strongly supported by the fact that it explains the unusual production of hypochlorous acid from chlorine attached to trivalent nitrogen.

But carbon tetrachloride cannot react in either of these ways. It has a complete octet, and cannot increase it, and the octet is fully shared, so that it cannot act as a donor. It therefore does not react at all. The remarkable inactivity of carbon tetrachloride has long been regarded as an unexplained anomaly, but we can now see that it is a necessary consequence of the theory of co-ordination. If we want to find a similarly inactive halide of an element in a later period, where a valency group of 12 is possible, we must obviously choose one in which this group of 12 is fully shared and also is incapable of further expansion. Examples of this are the hexafluorides of sulphur and selenium, whose inactivity is as remarkable as that of their carbon analogue. Tellurium hexafluoride on the other hand is hydrolysed by water, since its valency group of 12 can expand to 16, and the tellurium can therefore (like silicon in the tetrahalide) act as an acceptor.

Now the carbon atoms in an ordinary saturated organic compound all resemble that in the tetrahalide in having fully shared valency groups of the maximum size. They are therefore incapable of the most obvious form of reactivity, which begins by co-ordination with a reagent molecule: if they are to react at all, it must be through some other atom in the molecule. It is a significant fact that one of the most elementary rules of organic chemistry is that a carbon atom united only to other carbon atoms or to hydrogen or the halogens is very slow to react, but that the introduction of a single oxygen atom into the molecule facilitates reaction. The comparison of the paraffins with the ethers or alcohols, of the ethers with the esters and the esters with the acid anhydrides, or of the alkyl halides with the acyl halides, illustrates the effect which an oxygen atom may have on the stability of a molecule. It seems natural to relate this effect to the strong donor properties which oxygen exhibits, and to suppose, for example, that the rapid hydrolysis of an acyl halide is due to the formation through the oxygen of a compound

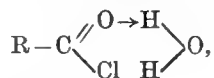

in which the hydrogen of the water is brought into close proximity with the chlorine, while the relative inactivity of an alkyl halide is the result of its inability to form such a compound.

I make these suggestions (which might easily be extended) because it seems to me that in the intensive modern study of the influence of structure on the reactivity of organic compounds this side of the question has been too much neglected. Great attention has been devoted to the consideration of the effect of other atoms in the molecule on the strength of a particular linkage. A new mechanism and a new terminology—or perhaps more than one—have been invented to account for the results. This mechanism is described in terms of physical concepts, and although it appears to me that the properties which are assigned to these concepts need considerable modification before they can be accepted by the

physicist, there is no doubt that this mechanism enables its inventors to correlate a large number of important generalisations, so that some real truth must underlie it, although we may at present be in some doubt as to what that truth exactly is. But I think these chemists have tended to rely too much on supposed modifications of the linkages within the molecule, and have not sufficiently considered the possibility of the formation of co-ordination compounds with the reagents employed, such as those which I have suggested above. The effect of one atom in a molecule in hastening the replacement of another may not be due merely to a weakening of the attachment of the latter, but may be caused by the formation of a co-ordinate link through the former, or this may promote co-ordination through some other atom in the molecule. We know now that even in purely 'organic' compounds—quite apart from those organo-metallic compounds which the old-fashioned organic chemist regarded with so much distaste—co-ordination is of frequent occurrence. In the particular form of the production of chelate rings, that is, in the form of co-ordination between two atoms of the same molecule, it has been shown to occur in β -diketones and β -ketoesters, in many ortho-substituted phenols, and in α -keto-oximes, and to be responsible for much of the chemical as well as the physical peculiarities of these substances; and in the more general form of association or 'molecular compound' formation its occurrence is widespread. Formerly the production of such compounds was ascribed to some inferior and rather contemptible form of valency, possibly to a force acting not between atoms at all, but between whole molecules, and so the influence of their formation on what were regarded as the reactions of genuine valencies was naturally taken little into account. But we now realise that they owe their existence to the production of co-ordinate links, and that the co-ordinate link is in essence the same as a normal covalency. The co-ordinated hydrogen, for example, as in

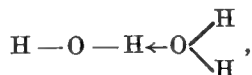

is attached to each of the two oxygen atoms by means of two shared electrons. The link on one side is just as genuine as that on the other, although, owing to the difference in the states of the two oxygen atoms, one of them may separate more easily. It therefore seems probable that the formation of such a link may often be a preliminary stage to the complete transference of the hydrogen from one point of attachment to another, and that the possibility of its formation may be a necessary condition of reaction. We have further to recognise another way in which reaction may be promoted by co-ordination, which is illustrated by the example I gave of the hydrolysis of an acid chloride. The formation of a co-ordination compound between two molecules may bring two atoms into proximity with one another, and so favour their reaction. In developing this possibility we have to consider the stereochemical relations. The study of chelate rings has shown us what forms of ring are most stable; owing to the weakness of the co-ordinate link which they contain such rings afford, as I have already pointed out, a more delicate test of strain than the ordinary rings of organic chemistry. Thus we find that a chelate ring of six atoms, including double links, is formed with peculiar

ease. From this we may conclude that when a chain of atoms is formed by co-ordination which includes one or two double links, the sixth atom of this chain will be able to approach the first very closely, and so may be expected to react with it. In these and other ways the consideration of possible intermediate co-ordination products may provide the clue to many organic reactions.

If this line of thought is to be pursued, there is a preliminary question which requires investigation. We have seen that two conditions are essential to the formation of a co-ordinate link, the presence of an atom with an unshared pair of valency electrons (the donor), and of another (the acceptor), which can add two electrons to its valency group. But these conditions, though necessary, are not sufficient. They are both fulfilled in most organic molecules other than those of hydrocarbons. The normal hydrogen atom has only two electrons, and it can hold four: every halogen atom, every oxygen atom, every trivalent nitrogen atom has an unshared pair of valency electrons; and yet halides, ethers, and amines are not as a rule associated. For co-ordination to take place it is necessary not only that such atoms should be present, but also that they should be so linked that they are able to exercise their donor or acceptor properties. Hydrogen, for example, is a powerful acceptor when it is joined to oxygen or fluorine; it is a weak acceptor when it is joined to nitrogen; it is practically not an acceptor at all when it is combined with carbon or one of the heavier halogens. We cannot at present explain these differences in behaviour, but it is quite easy to show that they exist. In the same way the donor properties of oxygen are very largely influenced by its state of combination. If the influence of co-ordination on reactivity in organic compounds is to be studied in detail, the first necessity is a knowledge of the factors which promote co-ordination itself, and this can only be attained by a careful examination of the facts from this point of view; a thorough investigation of the influence of substitution on the tendency of molecules of a particular type to associate with themselves, or to form addition compounds with other substances, would no doubt throw much light on the question. It would be particularly interesting to know what is the effect on activity, both in donors and in acceptors, of the peculiar tendencies to reaction which the modern organic chemist represents by positive and negative signs.

I have tried in these remarks to emphasise the fact that the modern electronic interpretation of the theory of co-ordination has a value far outside the range of those compounds which the theory was originally devised to explain. There is too great a tendency even now to regard the question of co-ordination as one which is of interest only in connection with a highly special group of substances which the ordinary chemist rarely meets, whereas in truth the study of this question has given us a wider and a truer conception of the nature of the processes by which molecules are built up. The determination of the factors which influence chemical reaction is perhaps the most important of the fundamental problems of chemistry, and it is essential that the factor of co-ordination, with the new possibilities of reaction-mechanism which it opens up, should be recognised and investigated.

SECTION C.—GEOLOGY.

THE TERTIARY PLUTONIC CENTRES
OF BRITAIN.

BY

HERBERT H. THOMAS, Sc.D., F.R.S.,

PRESIDENT OF THE SECTION.

IN presenting to you the subject of the Tertiary Plutonic centres of Britain, I do so with some diffidence, for of late years so much has been written concerning them and so much work has been done on related subjects that, of necessity, a great deal of what I am going to bring to your notice will not be new to you. I cannot pretend that I am armed with an array of fresh facts and observations, nor do I propose to follow the fashion and propound some new theory relating to petrogenesis. All I desire to do, and feel capable of doing, is to stress the importance of certain features displayed by the igneous rocks of these centres, feeling that they are not merely matters of local interest but are such as must influence fundamentally any conception of igneous intrusion and the explanation of the variability of rock-types and rock-composition.

The great Brito-Icelandic Province of Tertiary igneous activity, as you are well aware, stretches over a known area of some hundreds of thousand square miles, and so far as its major development is concerned, reaches from north-east Ireland, through the Inner Hebrides to the Farøe Islands, Iceland and beyond. Although broken up by the sea into more or less isolated areas that represent but a fraction of their original extent, these areas are sufficiently large and of sufficient relief to offer unparalleled opportunities for detailed study, both as regards the lateral and vertical distribution, and mutual relations of their component rock-masses.

In the early days the lava-field received the greater share of attention, and it was not till the later decades of the last century that the importance of the major intrusive bodies was either suspected or realised.

It is not necessary to delve into the early history of petrographical work connected with this region, but sufficient to pay tribute to the astute observations of such pioneers as Pennant, Ami Boué, Jameson and Macculloch, and to acknowledge the great debt that we owe to Judd and Archibald Geikie who, although often holding divergent views, together laid the sure foundations on which the whole fabric of subsequent work has been erected.

The definite establishment of the Tertiary age of the igneous rocks as a whole, the conception of a great petrographical province, and the proof that the lavas of the great field were of the plateau-type due to fissure-eruptions, constituted the first real advance in our knowledge.

What I may refer to, however, as the intensive study of the Tertiary

igneous rocks of Britain, made possible by the progress of petrographical methods and ideas, commenced when Dr. Harker undertook in 1895 the detailed mapping of the Island of Skye—work that led up to the production of the most complete account of any extensive and complicated region of igneous rocks which up till then had been presented to the scientific public. Later he extended his researches into Rum and the Small Isles of Inverness, where problems of a similar nature confronted him, and which he elucidated with the same skill and perseverance. Since that time the Geological Survey undertook and completed the investigation of what is probably the most complex, but at the same time most illuminating, plutonic centre in the Tertiary province, namely, the Island of Mull. Here many of the discoveries of Dr. Harker in Skye and elsewhere received ample confirmation, but, as might be expected from a region of greater size and complexity, many features that were obscure or unrepresented in the previously described region were made clear and established as matters of general importance.

A complete account of this region, prepared largely by Mr. E. B. Bailey, has now appeared and is probably familiar to most of you. No memoir, however good, can do Mull justice, and no student, even with the aid of map and memoir, can fully appreciate all that Mull has to teach without a study of the actual exposures. The companion centre of Ardnamurchan, although of smaller extent, is equally important because, in addition to reproducing many of the salient features of Mull, it supplements as well as confirms many of the deductions framed on work done in the larger area. Mr. Richey was mainly responsible for the survey of Ardnamurchan, and although references to the progress of the work have been made from time to time, the complete account of this centre has yet to appear. I am glad to be able to say, however, that the publication of the memoir on this interesting area will not long be delayed.

In other districts, the petrography of the Island of Arran, with its two centres, has been made the subject of revision by Dr. Tyrrell of Glasgow, who is now preparing an official memoir and explanation of the map. The Mourne Mountains in Ireland have received attention at the hands of Mr. Richey, and his account of the granite masses has been communicated to the Geological Society. Still farther afield, Dr. Hawkes, following on the work of Thoroddsen, has undertaken an investigation of the plutonic centres of south-eastern Iceland, the results of which we await with interest, while others have studied the remnants of the great Tertiary lava-field in even higher latitudes.

When Dr. Harker commenced his work in Skye the magnitude of the lava-field was fully appreciated, and in addition it was well known that breaking through this field were strictly localised intrusive masses of considerable extent. Till then, however, none of these plutonic areas had been studied in detail, the form and mutual relations of their component rock-masses were but imperfectly understood, and only the dominant rock-types had received serious attention. Now, practically every one of the Tertiary centres has come under review in recent years. Each has yielded its quota of new facts, and we have reached a stage at which generalization is both possible and legitimate.

The plateau lavas which rest directly upon a platform of denuded

Mesozoic and older rocks, as was shown by Geikie, and has been borne out by all subsequent observations, have emanated from a series of fissures formed by uniformly directed tensional forces acting in the earth's crust. Individual flows had no great thickness compared with their great lateral extent, they were more or less unaccompanied by any explosive action, and there was consequently little in the way of associated pyroclastic deposits. They were erupted on a land-surface and collectively made a covering that amounted to many thousands of feet in thickness. Even now, after ages of denudation, thicknesses of 3,000 feet can be measured.

They are the earliest and greatest expression of Tertiary igneous activity and as such first claim our attention in view of their bearing on later events. The similarity of type, widespread distribution, and great aggregate thickness of the plateau lavas lead directly to the supposition that beneath this north-west province lay an enormous intercrustal reservoir filled with a basic magma that differed not at all in composition from that of the lavas erupted at the surface. Further, this reservoir must have been situated at such a depth that its minimum temperature during the eruptive period was above the freezing point of any mineral constituent of the magma. For all normal silicate magmas, differentiation without crystallization is sufficiently improbable to enable us to dismiss the separation of immiscible liquid fractions from our considerations. Thus it would appear that the uniform composition of the lavas, the general absence of phenocrysts of intratelluric character and the scarcity of cognate xenoliths may be taken as indications that crystallization and consequent differentiation had not proceeded to any extent, and that great depth and related elevated temperature were the restraining factors.

It does not concern us particularly what produced the tensional stress in the crust with its accompanying fractures. It is sufficient to realise that such a state of tension undoubtedly existed and that consequent crustal weakness allowed large portions of the region to founder. The causes have recently been discussed by Dr. J. W. Evans, who attributes them to isostatic adjustment between the north-western continental area and the Atlantic deeps.

The foundering of the crust either as a whole, or more likely in restricted but ever changing areas, produced the uprise of magma in the fissures and the general outpouring of the plateau lavas; and we may assume that the end of this eruptive period coincided with temporarily restored equilibrium. The next phase appears to me to be the local subsidence of the roof of the deep-seated magma-basin. These local subsidences must have been more pronounced than the general settling that was responsible for the extravasation of the plateau lavas, and the magma, instead of merely rising up more or less restricted fissures, ascended to take the place of the locally subsiding crustal masses. The reason for this assumption is that within the primary magma-basin differentiation was restrained by depth and elevated temperature. Further, the initial temperature would not be reduced to any extent by the outpouring of the lavas. Therefore, for differentiation to take place, portions of the original magma would have to occupy reservoirs of a local character situated in a zone of the earth's

crust where the temperature gradients would permit the cooling of the magma below the crystallization point of some or all of its constituents. The origin of localised centres of highly differentiated intrusive rocks, such as those with which we have to deal, appears to me to be inseparable from the idea of pronounced local subsidences.

The first expression of local activity, as in Skye, Mull and Ardnamurchan, usually takes the form of vent-agglomerates, or explosion-breccias, which are the result of the explosive shattering and brecciation of the country-rock—most frequently the plateau lavas. The magma responsible for the formation of these agglomerates is invariably of acid composition, and it may have actually broken through, producing a true vent, or merely effected intense shattering of its roof. These agglomerate-masses or vents were presumably formed by the action of the highest liquid portion of a more or less completely differentiated magma that filled a local reservoir. If the magma prior to differentiation had ascended to within a reasonable distance from the surface, as differentiation progressed the pressure due to accumulation of gases in the acid differentiate would increase, and cause it to break through and shatter the remaining portion of the crust. The first intimation of its presence would be the formation of agglomerates, followed or accompanied by the outpouring of acid igneous material of rhyolitic or trachytic composition. Such appears to have been the manner of formation of the Kilchrist vent in Skye, which breaks abruptly through the adjacent strata and has almost vertical sides with a roughly cylindrical form. Vent-breccia or agglomerate plays a very significant and conspicuous part in the geology of central Mull, and its distribution clearly outlines the two important calderas of that region. Although explosive action on the part of an acid magma was repeated at several periods in the history of Mull, such was one of the earliest, if not the earliest, manifestations of central activity. In Ardnamurchan, in the neighbourhood of Ben Hiant, and conforming to the outline of the plutonic centre, large accumulations of vent-agglomerate break through the older strata and are associated with rocks of trachytic character and composition.

It appears to be fairly certain that the intrusive centres of Skye, Mull, Ardnamurchan and probably central Arran were marked out by the explosive breaking through of a magma of acid composition. In Mull there is evidence of the strongest kind that magma continued, under repeated subsidence, to be erupted with the temporary establishment of a volcano of Hawaiian type.

From this point onwards in each centre we enter a period during which all the major plutonic masses were intruded, and I should now like to offer some generalizations on the forms they have adopted. A glance at the published geological maps of Skye and more particularly of Mull will at once reveal the fact that the major intrusions have circular, annular, or crescentic form around some central point. A review of all the Tertiary plutonic masses of Britain, as well as those of south-east Iceland, brings out the fact that laccolitic intrusions are the exception. By laccolitic I mean intrusions that have definitely forced up and displaced pre-existing rocks to make room for themselves, or occupy domed regions, and have a well-defined base. Most of the Tertiary plutonic masses appear to have

no recognisable bases but seem to extend indefinitely downwards so far as the accessible portions of the crust are concerned. Similarly in Iceland Dr. Hawkes finds that the true laccolitic form of intrusion is seldom met with. This is in accordance with the generally accepted view that laccolites are associated with mountain-building movements, whereas everything points to the intercrustal stresses in the Tertiary province having been of a tensional character.

The main plutonic masses of Mull have been shown by the Survey to be due to the rise of magma up ring-shaped or arcuate fissures caused by the general subsidence of a central area. Such fissures are, as might be expected, either vertical or steeply inclined in an outward direction. They thus tend to bound either a cylinder or a steep angled cone.

Subsidence of a conical block or cylindrical mass of crustal material into a magma-reservoir would naturally cause a welling up of molten matter into the fissure that bounds the subsiding mass. If the fissure reached the surface a cauldron-subsidence similar to that of Glencoe would probably be established, and eruptions of central type would ensue. If, however, the ring-fracture, instead of reaching the surface was completed by a truncating cross-fracture beneath the surface, the magma would not only ascend along the sides of the subsiding mass but would insinuate itself in the form of a sheet between the top of the sinking mass and the relatively stable crust. The thickness of this practically horizontal sheet would depend upon the amount of subsidence of the block beneath, while the thickness of the cylindrical part of the intrusion would be determined by the inclination of the ring-fracture to the vertical together with the amount of central subsidence. Repeated subsidence that would allow fresh influxes of magma in the widening fissures, or the formation of fresh fractures of a similar kind, would give rise laterally to a succession of ring or arcuate intrusions arranged about a common vertical and generally central axis.

To such intrusions the term ring-dyke has been applied, but it will be seen that in their most complete form, that is to say when the steep ring-like portions of the intrusion are connected transversely, they present points of similarity to stocks. In fact, in this case, the difference appears to be one of degree rather than of kind, for it is quite probable that many stocks, if sufficiently denuded, would reveal a ring-dyke structure in depth.

Subsidence with the quiet welling up of magma from beneath gives rise to intrusions that have one great distinguishing feature from those which are due to the forcible injection of magma, or which occupy regions affected by mountain-building forces. They will not disturb to any extent the rocks into which they are intruded but will simply replace a definite block of the pre-existing crust, and at the same time transgress without serious modification all pre-existing structures. Such were found to be features presented by the ring-intrusions of Mull.

A further point of interest is that within the same area of general subsidence the centre of actual subsidence may, and does, shift its position, so that an earlier series of ring-dykes may be intersected by another series of later date, of which the axis is not coincident with the first but removed some distance from it. In Mull the successive centres of subsidence

responsible for the two suites of ring-dykes are separated from each other by a distance of about two miles. The earlier centre lies to the south-east and the later centre to the north-west, situated in the neighbourhood of Loch Ba.

It was not till the mapping of Mull had progressed towards completion that it was recognised how characteristic and prevalent was the ring-dyke type of intrusion, but Dr. Harker's description and mapping of central Skye made it quite clear that ring-dykes were there represented, more particularly in the region of the Red Hills. His description of the composite nature of the main granophyre, its vertical western margin, its arcuate inclusions of older plutonic rocks, and on the eastern side its relation to the older sedimentary rocks, are in perfect agreement with those of the ring-dykes of Mull. He emphasises the steeply inclined or vertical boundaries and the almost flat or slightly domed roof so characteristic of this type of intrusion.

Since the detailed study of Skye and Rum three additional plutonic centres have come under review, namely Ardnamurchan, the Mourne Mountains and Arran.

Mull must always be regarded as the type area of ring-dyke intrusion, especially as it possesses in the Loch Ba felsite, one of the intrusions around the later centre, the most perfect example yet met with. The neighbouring centre of Ardnamurchan, however, offers most striking instances of ring-dykes, and being less complex than Mull or Skye the relations of the rock-bodies to each other and their forms are readily understood and appreciated. The forthcoming memoir on this district should prove an interesting sequel to those on Skye and Mull.

Mr. Richey, who spent many years mapping the peninsula, has established at least two suites of ring-dykes, one intersecting the other and with centres of subsidence situated more than a mile apart. A third, but less obvious centre, is the earliest, and, from the agglomerates which appear to be related to it, marked the initiation of the Ardnamurchan centre as a whole. It is the latest series of intrusions, ranging from eucrite to monzonite, that most clearly exhibits the typical features of ring-dyke injection. The steep junctions, the intercalation and metamorphism of older rock between successive intrusions, the sharp transgression and disregard of pre-existing structures, and the welding of intrusive junctions with a general absence of structures due to chilling, are all features that we have come to recognise as peculiar to ring-dykes. No roofs are now preserved, denudation having been very severe, but it is practically certain that several of the ring-dykes were connected across the area of subsidence by transverse continuations.

Carrying his work farther afield, Mr. Richey has lately demonstrated that in the Tertiary granites of the Mourne Mountains we have a very clear case of ring-dyke intrusion due to central subsidence. He has found that the Mourne granite, instead of being one simple intrusion, comprises four successive intrusions, one within the other, the outermost being the oldest and the innermost the most recent. Further, that these intrusions were effected without any disturbance of the strike or dip of the neighbouring Lower Palæozoic rocks, a fact which shows that the magma did not force apart the rocks into which it was intruded, but

merely replaced, bulk for bulk, a mass of solid crust which had foundered and has completely disappeared. Although not perfectly symmetrical, the relations of the successive intrusions to each other, and to the country-rock, are typically those of ring-dykes. The granites show to perfection their roofs as well as their bounding sides, and demonstrate how the vertical or steeply inclined walls turn abruptly into a slightly domed roof. In this respect the intrusions closely resemble the granophyres of Beinn a Ghraig and Knock in Mull, which have replaced a great mass of lavas and minor intrusions without disturbing the arrangement of the adjoining country-rock. Mr. Richey states that no floor can be detected to the Mourne intrusions. He postulates that overhead piecemeal stoping has played no part in allowing the rise of magma, and that the space occupied by the various granites has probably been provided by a subterranean cauldron-subsidence of the pre-existing rocks.

In 1900 Gunn discovered a large oval area, about four miles in diameter, in central Arran, which consisted of fragmental rocks in close association with numerous igneous masses, and which he described as a volcanic vent. Dr. Tyrrell, as the result of recent work in the island, clearly recognises in this vent a ring-complex, which, though less perfectly preserved than those of Mull, Ardnamurchan and Skye, he considers to have had an equally long and complicated history. The main complex is outlined by masses of explosion-breccia, of which the formation was concomitant with the intrusion, and possible eruption, of an acid magma that ascended an arcuate fissure bordering the vent. It probably occupies the position of, or intersects, an older complex, for gabbros and other basic plutonics of older date are cut by it and also enter into the composition of the explosion-breccias.

It is interesting to find within the region of the complex isolated masses of plateau basalt preserved from denudation. Their presence points to two facts: firstly, that before the initiation of the central area, plateau basalts had been erupted as in other districts; and secondly, that their preservation can only be accounted for by assuming subsidence of central type.

In the north of Arran a granite mass, some eight miles in diameter, occupies an almost circular area outlined by Dalradian schists. This mass also is regarded as being of Tertiary age, although definite proof is lacking. Its relation to the surrounding sedimentary rocks and its general likeness to the granites of the Mourne Mountains and of the central complex of Arran are certainly strong evidence for its intrusion in Tertiary times.

Although a feature usually associated with laccolitic intrusions, it has been proved in Mull and elsewhere that individual ring-dyke or stock-like masses may arch their roofs when they develop an excess of pressure—either hydrostatic or due to dissolved gases. This arching, as in the Mournes, is usually quite gentle; but if carried to a greater height than usual, Mr. Bailey considers that the centrifugal forces acting within the unconsolidated magma in the higher portions of a cylindrical intrusion will exert an outward pressure on the containing walls. The relief of this pressure, he argues, would be accomplished by the arcuate folding or wrinkling up of the surrounding strata, and be accompanied by a

lateral spread of the magma and depression of its roof. This theory was put forward by Mr. Bailey to explain the pronounced overfolding of the margin of the north Arran granite previously referred to, but it appears to be equally applicable to the arcuate folding that surrounds the south-eastern caldera of Mull. The folding in the latter instance was presumably caused by early intrusion of granophyre (Glas Bheinn granophyre) guided, as has been suggested, by the peripheral ring-fracture that bounded the area of central subsidence.

Dr. Daly, writing two years ago on the relation of mountain building to igneous action, commented upon this very case, and suggested that the arcuate folding was possibly due to the centrifugal sliding of large fragments of a complex dome which had become unstable because of its high elevation and the weakening of the interior by magmatic injection. The difference between the views of Dr. Daly and Mr. Bailey is that the former would make the folding subsequent to the formation of the dome, while Mr. Bailey would regard the doming and folding as practically contemporaneous phenomena dependent upon the intrusion of the igneous mass.

Iceland, although affording good examples of ring-fractures, has not so far been credited with ring-dyke intrusions. In the plutonic regions of the south-east all but one of the intrusions examined by Dr. Hawkes are stocks, which, like the ring-dykes of Britain, have been intruded in tensionally stressed regions. Of these the granophyre stock of Slaufuradal is one of the most beautiful examples of its kind. It is elliptical in outline, has steeply inclined walls and an almost flat roof. It is exposed to a depth of more than two thousand feet, and the almost horizontal plateau basalts that constitute its walls and roof are absolutely undisturbed. Such a form of intrusion is that which I consider the earliest member of a ring-dyke complex is most likely to assume.

The one exception, in Iceland, to the perfect replacement of country-rock without disturbance of the surrounding strata is the plutonic mass of Faskrudsfjord. In this case Dr. Hawkes informs me the basalts are tilted into an almost vertical position against the intruding granophyre, and there are other signs of forcible disturbance of the country-rock.

As a generalization, however, we may state that the ring-dyke, or stock, with its circular walls and flat or gently domed roof, is the type of intrusion that specially characterises the plutonic centres of the Tertiary province. It should certainly be borne in mind when studying the form of intrusions that a simulation of laccolitic intrusion can be produced, as we have seen, by the lateral spread of magma in the upper portion of a domed intrusion of ring-dyke type.

One of the most important discoveries of Dr. Harker in Skye was his detection of a great group of basic sheet-like intrusions that were inclined inwards towards a definite centre. He demonstrated that their distribution and their regular inclination towards the centre of the great gabbro intrusion of the Cuillins proved them to be a local group connected with the gabbro-centre, though much younger than the plutonic rocks themselves.

When Mull and Ardnamurchan were surveyed it was found that inclined sheets, or cone-sheets as they have been synonymously called by the Survey, played even a more important part than they did in Skye.

In these last-named regions they exist as the usual sheet-like intrusions, directed towards the apex of an inverted cone which is situated deep down in the plutonic centre. They constitute a very definite and important stage in the igneous history of the respective regions. Although of great thickness, they exhibit a marked constancy of type, but have been intruded at more than one period.

The most interesting feature connected with their distribution in Mull is that each successive centre of subsidence has its own suite of cone-sheets, a fact that even more than their central inclination seems to connect them with the respective ring-dyke centres. The same is true in the case of Ardnamurchan, for here also each of the two centres has its related cone-sheets.

Cone-sheet intrusion, therefore, is definitely connected with the establishment of a local magma reservoir beneath an area of central subsidence. It is a phenomenon that can be repeated on several occasions during the formation of a ring-dyke complex, but it generally comes to an end before the last plutonic members of the complex have established themselves. In Mull the Loch Ba ring-dyke is later than all the cone-sheets, and in Ardnamurchan the inner and later members of the complex appear to be quite free from such intrusions.

The relation of cone-sheet to ring-dyke intrusion has been discussed theoretically by Mr. Anderson, who attributes the conical fracturing and the subsequent injection of magma to the development of excess pressure in the upper portion of a cylindrical or parabolic magma-reservoir. He proves that in the event of an increase of pressure in the magma-basin the crust above would have superimposed upon it a system of tensions acting across surfaces which near the basin are roughly conical. At the same time a system of upward pressures would act across surfaces that were parallel to the roof of the magma-basin. The effect of such forces would be the opening of conical fissures followed by the uprise of magma from the reservoir beneath.

Expressed in other words, the production of cone-sheets may be described as the result of an effort on the part of a deep-seated magma to raise its roof by fracture rather than by flexure. The uplift of a roof by such means is purely differential, but in the aggregate the uplift, as gauged by the cone-sheets, must be very considerable. In Mull the combined thickness of the cone-sheets reaches several thousands of feet, and Mr. Bailey considers that the central elevation which they denote is quite comparable to the doming of the roof of the Arran granite.

A highly characteristic feature of certain of the plutonic centres, such as Mull, Arran, and the Mourne Mountains, is the occurrence of swarms of basic dykes. These dykes, which show a definite orientation, are crowded together in the region of the plutonic intrusions but extend far beyond the limits of the areas of local subsidence. It is clear, therefore, that their intrusion was influenced but not wholly controlled by these centres. The Mull swarm has a width of some 8 miles and is over 100 miles in length. Such dyke-swarms, related to older plutonic intrusions, are well known in the regions of the Ettive and Ben Nevis granites.

In the Tertiary province intrusion of the dyke-swarms extended over a considerable period, but was determined by a renewal, possibly in a less

acute form, of the great tensional stresses that preceded and accompanied the extrusion of the plateau-lavas.

The crowding together of the dykes in a region of central subsidence can only be explained by assuming that such regions fractured more readily and were possibly subjected to greater tensile stresses than the country on either side. Further, this intense fracturing could only occur if the tensional stresses were acting on a relatively thin crust and tangential to the upper surface of a reservoir filled with liquid or plastic material. We are, therefore, led to the conclusion that the dyke-swarms must be due to a general rise of the primary basalt-magma, and that this rise was accentuated in the regions of central subsidence. The magnitude of the tensional stretch in these regions can be gauged by noting the aggregate thickness of dykes in a given distance. In Mull it was found to be about one mile in twenty-four, while in Arran the stretch is even greater and amounts to as much as one mile in eight or ten.

I have only touched upon a few features of the dominant and most interesting types of Tertiary intrusions, but before leaving this part of the subject I would like to refer to the mutual relations of some of these bodies to each other and to the rocks into which they have been intruded.

In unravelling the structure of an igneous complex two essentials confront us: firstly, the proof that any rock-body is a unit and not composite, and secondly, its absolute or relative age. In the case of most intrusions we apply the criteria of chilled margins and contact metamorphism, but this necessitates a relatively low temperature for the rocks into which the intrusion penetrated. With the ring-dyke complexes, however, the intrusions, other than the dykes, sills and cone-sheets, are of considerable magnitude and fairly deep-seated; while as regards time they followed closely upon each other. Thus, frequently, the cooling effect of an earlier intrusion upon one of later date is not well marked.

In Mull, and also in Ardnamurchan, it is not usual for the ring-dykes, especially those of more basic composition, to show markedly the ordinary effects of rapid chilling at their margins. Instead, there is usually some slight assimilation of the country-rock and formation of narrow transitional belts between contiguous intrusions.

Extreme cases of the interaction of an intruded magma with an igneous rock of related but different composition have been described by Dr. Harker, first from Carrock Fell and later from Skye and elsewhere. To rocks due to such a process he gave the now well-established name of hybrids, and he called the process of interaction hybridization.

When the rocks have interacted or hybridized at their contact with each other it is not always easy to discover whether we are dealing with a single intrusion locally differentiated, or with an intrusion of composite nature; for the results of partial differentiation and the effects of hybridization have much in common. It is, however, in such cases that what the officers of the Geological Survey have termed screens come to our assistance.

A screen is a narrow mass of country-rock separating two neighbouring steeply bounded intrusions, and older than either of them. Such masses separating ring-dykes will have curved outcrops, and are the logical sequel to the alternate fissuring of the walls of a centrally subsiding area.

They may be formed of portions of older ring-dykes or other intrusive masses, lavas, or pre-Tertiary sediments. They usually show a fairly high state of metamorphism for they have come under metamorphosing influences from both sides. Igneous rocks in screens generally show recrystallization and granulitization, while sediments have usually been hornfelsed in a manner dependent on their respective original composition.

Such masses locally interpolated between two intrusions that elsewhere have reacted with each other at their junction, will at once free us from doubt: firstly, as to the separate nature of the intrusions, and secondly, as to their relative ages.

In Mull, screens were found to be of the utmost value in determining the relations of the intrusive rock masses to each other, and the same has proved to be the case to a like degree in the ring-dyke complex of Ardnamurchan.

Turning now to a consideration of the composition and origin of the major intrusions, the fact that impresses us most is the remarkable and more or less constant association of widely divergent rock types. All through the Tertiary province of Britain and Iceland gabbros and granophyres or granites are the dominant plutonic intrusions, and may be said to characterise the province as a whole. There can be no question that these types are more or less extreme differentiation products of a common magma, and this magma we may reasonably infer was that which supplied the plateau basalts. Except in the case of certain cone-sheets, dykes and other minor intrusions, this magma in an unmodified state is unrepresented amongst the Tertiary intrusions. All the plutonics, as well as the majority of the cone-sheets and sills, are products of a magma that must have substantially changed its composition. In other words, almost every rock type, excepting those specially mentioned, is a product of differentiation. This fact leads us to the unavoidable conclusion that differentiation had at any rate commenced in the local intercrustal reservoirs beneath the plutonic centres before any intrusion into the upper part of the crust was effected.

The gabbros and granophyres often occur, either alone or together, without any rocks of intermediate composition, but these latter are occasionally well represented, as in Mull and Ardnamurchan, by minor intrusions such as sills and cone-sheets and occasional larger masses. Taken as a whole the rocks of intermediate composition are of considerable bulk, and therefore their corresponding magma should be given an honourable place in any scheme of differentiation. As to the manner in which differentiation was effected, we are convinced that the differentiation of a normal magma cannot be accomplished by any process that does not depend primarily upon the separation from it of solid crystalline phases. Recent work both in the field and in the laboratory demonstrates that there is no necessity to call to our aid such theories as those of dual magmas, immiscible liquid fractions, or magmatic assimilation to account for the differences of composition displayed by the major intrusions.

In all the Tertiary centres the plutonic masses show but the feeblest attempt at differentiation in place, and thus it is clear, with one notable exception, that such variation of rock type as is met with was determined before the respective magmas came to occupy their present positions.

Now, the course of differentiation of a complex silicate melt, as suggested by the relative freezing points of the various constituents, would be the separation by crystallization of the more basic constituents from a residuum that became progressively more acid as crystallization proceeded towards complete solidification. If by any chance, as some have held, crystallization of early phases in the upper portions of a magma reservoir led to a settling and remelting of these constituents in the lower and hotter regions, it is conceivable that an exaggerated diffusion-column might be produced, with denser basic material below, and lighter acid material above. The effect, however, of a crustal mass subsiding into such a differentiated but wholly fluid magma would be to produce intrusions of a progressively basic character. The upper acid portion would be intruded first, and the more basic subsequently; also, it may be inferred that none of these intrusions would be true to type, but that they would exhibit excessive variation on solidification.

Such conditions would give rise to an igneous cycle that, so far as the plutonic rocks are concerned, is exactly the reverse of what is encountered in nature. In all the Tertiary plutonic centres it has been clearly established that the order of intrusion of the plutonic rocks is invariably from basic, or even ultra-basic, to acid.

If we agree that differentiation is due to the separation and settling of crystals and culminates in complete solidification, any intrusion drawn from a basin other than the residual liquid fraction of the period must be consequent upon remelting. I agree with Dr. Harker in regarding the process of remelting of the already differentiated magma as the only means whereby the basic to acid order of intrusion could be induced or maintained.

It would appear that a local intercrustal reservoir established as an upward extension of the primary magma, to take the place of a centrally subsided crustal mass, became more or less completely differentiated before it made its presence felt at higher crustal levels. The fact that the explosion breccias which heralded the plutonic intrusions are associated with an acid magma, or rather an acid differentiate of a basic magma, shows that differentiation within the basin had almost run its course.

It will, however, be readily understood that, without remelting, pressure produced by a crustal block subsiding into a magma reservoir could only cause to be exuded such a portion of the differentiated magma as still retained its fluid state, and in no case could this fluid be as basic as the original magma. That an acid differentiate may collect in a liquid form in the upper portion of a magma column or reservoir when the rest is solid has been argued by Bowen, and it is certainly probable that many acid intrusions originated in this way without the intervention of remelting. In this connection we may cite the case of the quartz-dolerite magma, itself a product of differentiation.

The quartz-gabbros and quartz-dolerites form some of the ring-dykes and late basic cone-sheets of Mull, and some of the older ring-dykes and most of the cone-sheets of Ardnamurchan. These rocks were derived from a magma which as crystallization progressed clearly gave rise to an acid differentiate. This acid partial magma was of strikingly different composition from the early crystalline phases, and its temperature of complete consolidation was evidently far below that at which the larger and earlier

individuals had practically ceased to grow. It represents the original basalt magma almost depleted as regards lime and magnesia, but retaining abundant alkalis and dissolved water. It evidently retained its fluidity over a fair range of temperature and would thus be capable of separation under gravity or any externally applied stress. This process of the migration of the acid differentiate can be studied in the Carboniferous quartz-dolerites of the Lothians, and we assume that it has taken place under the action of gravity in the quartz-gabbro ring-dyke of Glen More in Mull.

It would appear, therefore, that stresses produced by subsidence acting upon a partially differentiated magma of this character could bring about the separation of the fluid acid differentiate and cause intrusions of granophyre or allied rocks.

The separation of an acid differentiate that exists in the interstices of an almost solid magma, by external stress, has repeatedly been used by Dr. Bowen to account for the close association of widely divergent rock-types. He considers that an external pressure applied to a magma that had become about 80 per cent. solid by the formation of a mesh-work of crystals could break down this mesh-structure. The interstitial liquid would then feel the pressure which would be transmitted hydrostatically to all parts, and if continued would produce a separation and intrusion of the acid differentiate in a comparatively pure state. Such action is supported by the frequently bent and broken state of feldspars and early formed augites of the quartz-dolerites.

Although the magmatic sequence, in Ardnamurchan, is from basic to acid, like that of other centres, the ring-dykes almost invariably have margins of varying width which are more acid than the bulk of the rock forming the particular intrusions. In these less basic margins we certainly see, not the result of differentiation in place, but the effects of the injection and partial chilling of a magma that was followed immediately by one of somewhat more basic composition. Such a condition of things might conceivably be brought about by the subsidence of a crustal mass into a basin filled with partially differentiated magma. The first portion to be intruded would be that richer in the acid differentiates, while as subsidence continued there would be an uprise of the more basic and less differentiated magma that represented the bulk of that contained in the upper part of the reservoir. Such a process appears to me to be the explanation of the quartz-dolerite margins to the Ardnamurchan gabbros and eucrites, and the felsitic margin to the tonalitic ring-dyke of the central complex.

The alkaline rocks call for passing notice on account of the varied and sometimes fanciful suggestions put forward to explain their origin. In the Tertiary province they form a very insignificant group so far as bulk is concerned, but are important on account of their unusual composition. In the plateau-lavas certain segregation veins that represent a late phase in the consolidation are of definitely alkaline character. They prove that the differentiation of the plateau basalt magma, even under superficial pressure and rapidly falling temperature, is capable of producing rocks of alkaline character. Dr. Bowen on theoretical grounds concludes that the alkali-rocks can, and do, originate from the same primitive magma as the

calcic rocks, and that the separation was the result of differentiation under stress. In this he is supported by a great number of petrologists, and so far as the evidence of the Tertiary province is concerned, no other explanation appears possible.

If we consider the course differentiation has followed to produce the various rock-types met with amongst the Tertiary plutonic rocks we find that it depends chiefly on three factors which are, the separation of olivine and lime felspar and the production of a quartz-rich and alkaline residuum.

The formation of a magma supersaturated as regards silica from one of basaltic composition was for long regarded as improbable. Now, however, on theoretical and experimental grounds there appears no difficulty in developing quartz from a hydrous basic magma. Whatever the explanation, however, no one studying the intrusive rocks of Mull and Ardnamurchan in the field could for a moment doubt the consanguinity of the abundantly represented quartz-gabbros and quartz-dolerites and their more basic associates the normal gabbros, eucrites and peridotites.

It appears that the differentiation of the plateau basalt magma has been responsible for the production of two magma-types, which as differentiation progressed converged in the direction of increasing acidity and alkalinity. The representative rock-members of each magma are linked together by common compositional characters that are certainly of genetic significance.

In Skye, Mull and Ardnamurchan we find that the basic major intrusions constitute a group of rocks that on a chemical basis of comparison are richer in alumina, lime and magnesia than corresponding members of the normal magma series. These more basic rocks suggest that their origin lay in a basaltic magma enriched by the addition of the constituents of lime-felspar and olivine, either singly or together. It follows that the magma supplying the enrichments will be correspondingly poorer in olivine and the basic plagioclases, and proportionately richer in alkali-felspar and quartz.

The differentiation characteristic of the normal magma series is the rapid fall in the percentage of lime, magnesia and iron, with a more or less constant percentage of alumina, and a rise in alkalis, more especially of potash. Such variations point to the continued separation of non-aluminous ferromagnesian minerals as being the dominant factor in the differentiation. The general increase in the alkalis and the relative concentration of potash is undoubtedly due merely to the separation of soda-lime felspar. Such a differentiated magma would account for the non-porphyrific central types of lava in Mull, the intermediate and sub-acid intrusive rocks, and the great group of granites, granophyres and felsites. All these rocks can be derived from the plateau-basalt magma by the normal process of the crystallization and abstraction of one or more solid phases, and the separation may be produced either by the gravitational settling of the crystals, or the removal of the liquid residuum as the result of stress.

The other magma-type is responsible for the gabbros and related rock-types. It appears to be a magma of plateau basalt composition enriched by the addition of olivine and lime-felspar. Its character, as reflected in the gabbros of Skye, Mull and Ardnamurchan, and carried on into the tonalites and monzonites of the last-named centre, is the generally

high percentages of alumina, lime and magnesia when compared with the plateau basalt and rocks of the other series with similar percentages of silica. Thus, for instance, the normal quartz-dolerite magma, represented in Mull and Ardnamurchan by innumerable sheet-like intrusions, and by the great mass of Ben Hiant, has a similar silica percentage to the magma represented by the quartz-gabbros of these regions. The quartz-gabbro magma, however, is richer in lime and alumina, a fact that indicates a concentration of lime-felspar greater than that encountered in the plateau-basalt and its normal derivatives.

One other point. There are still petrologists who see in the variation of igneous rocks the results of wholesale contamination of a magma by the assimilation of country rock. But, whatever the evidence elsewhere, in the Tertiary province the idea of serious modification of a magma by such means receives no support.

The chemical and mineralogical characters of all the major intrusive bodies are quite normal and are just such as would be presented by straightforward differentiates. A study of the margins of intrusive masses shows that the effects of interaction and assimilation are quite local, of relatively insignificant extent, and where encountered are distinguished by characters that are unrepresented in normal igneous rocks. Even where interaction between a magma and its retaining walls can be presumed, as in the case of the magma that supplied the xenolithic sills of south-west Mull, the extent of interaction was very limited. It would appear that a narrow reaction zone was established and that the early precipitation of insoluble phases in this zone protected the country rock from further attack. The magma as a whole remained unmodified, and the reaction zone presented quite abnormal chemical and mineralogical characteristics.

If assimilation was going to be operative on a large scale the place to look for it would be in the deep-seated basin of the primary magma, where elevated temperatures and the unsaturated state of the magma as regards silica would be in its favour. The greatest argument, therefore, against serious magmatic modification by assimilation is furnished by the repeated appearance of the plateau basalt magma throughout the Tertiary province in an unmodified form at widely separated periods—first as the plateau-lavas, then as cone-sheets and sills, and lastly as basic-dykes.

SECTION D.—ZOOLOGY.

THE ANCIENT HISTORY OF SPONGES
AND ANIMALS.

ADDRESS BY

G. P. BIDDER, Sc.D.,
PRESIDENT OF THE SECTION.

AMONG animals, man alone knows of a past and hopes for a future. Our life is still delightful, because still we do not know what will happen an hour from now ; but as the intellectual development of man has increased, so has he lengthened his conscious past.

The Cambrian, as the lowest of our fossiliferous rocks, used to be considered the limit of life. With masterly insight Darwin concluded, on purely evolutionary grounds, that living things were on the earth for as long a time before the Cambrian epoch as they have been since. Huxley and Poulton—two great names in our history—showed that such a time must be measured by the hundred million of years. They maintained, against the full strength of Section A, the power of biology and geology to prove the important *physical* fact, that for hundreds of millions of years the world had been cool enough for habitation.

The past has lengthened now for mathematicians ; they have enriched us with the time-scale of radio-activity, and proved Darwin, Huxley and Poulton to have been right. They show that the ocean has existed for more than 1000 million years at a habitable temperature, and promise us the great boon of a date for every geological formation. We may gather from Jeffreys¹ and Holmes² that the constants for the time-scale of the age of rocks are rapidly approaching certainty, but that the constants of the lunar theory and the knowledge of geophysics and palaeogeography are not yet sufficiently ascertained to determine the height of tides in the sea five hundred or a thousand million years ago.

I wish to draw your attention to the great denudation just before the Cambrian, and to biological indications that it was produced by a period of gigantic tides, on such a cataclysmic scale as gravely to interrupt the sequence of evolution.

Beneath the Cambrian in Scotland is the Torridonian sandstone, in which Geikie³ describes some two miles thick of peacefully bedded sandstones, with shales and sea-beaches, deposited over an old land-surface of

¹ 'The Earth.' Cambridge, 1924, University Press.

² 'The Age of the Earth.' London, 1927, Ernest Benn. (Price 6*d.*, and worth a guinea!)

³ Text-book of Geology. Vol. ii, pp. 877, 891, 892. London, 1903, Macmillan.

hill and valley. But he gives a powerful picture of the tremendous water-erosion which followed this quiet period. Everywhere the top of the Torridonian is eroded; in one place a channel has been cut 4000 feet deep and miles wide. It is cut down to the Lewisian gneiss underneath, and it seems from Geikie's description that the total depth of erosion was probably 10,000 feet.

I will ask you to consider Zoological evidence that the denuding torrents of this period were succeeded by terribly strong currents in the Cambrian Sea, still powerful in the Ordovician, only returning to tranquillity with the advent of the Devonian.

In the Silurian we have no signs of the loafing, carp-like fish which so characterise the Devonian. The Silurian fauna, outside some deep-water creatures, with one group of very powerfully swimming fish, consists largely of animals specially adapted to hold on for their lives in a terrible current. Trilobites have centipede claws to clutch with, and a low, flat body shaped like a mud-shoal in a stream, or like Major Segrave's racing-car. The ostracoderm fishes, instead of claws, have to trust to the weight of their massive bones to press them in the mud; they are armoured to resist the battering of the stones driven by the tide; they are shaped, like the trilobites, in stream-lines, so that the resistance offered to the current is the least possible, and the resultant pressure holds down flatly and firmly the similar forms of fish, trilobite, motor-car or mud-bank. The fish *Cephalaspis* is so like the trilobites *Paradoxides* and *Olenellus* that Gaskell claimed they proved the descent of vertebrates from crustaceans. The resemblance is the convergence of very diverse animals, shaped to resist destruction from the same 10-knot current. Each is armoured, with a flat stream-line carapace and eyes as far out of the mud as is possible; in each the parabolic crescent of the carapace is prolonged in two lateral spines, which not only carry back a stream-line revetment around the mobile body, but also are driven splaying into the sand, if the animal is pushed back by the current, and anchor it like the flukes of a grapnel. The four-spined Cambrian trilobite *Crepicephalus* anchors more securely than those of the Silurian; it was moored fore and aft, having two earwig-like spines at the end of the abdomen.⁴ The armoured fish *Pterichthys* has a flipper on either side, which, as he is pressed backwards through the mud, will spread out to a click at right angles, like the barbs of a harpoon. If a trilobite be forced from his hold, he coils into a ball and rolls, so as to take glancing blows only. This chance of life, if driven from moorings, seems to be taken by some spherical shells such as the brachiopod *Rhynchonella*, and by the extraordinary armoured sponge, *Ischadites*. The fish-lamprey *Palaeospondylus* held on by a sucker to a smoothed rock, the crinoids were thickly plated and rooted to the bottom, polyzoa and corals were massive. Before the Caledonian upheaval and the Devonian period, we see a world of mud, clattering stones, and torrential currents.

I suggest also that the absence of terrestrial life shows that the Torridonian continents had been smoothed so flat that the Cambrian tides swept over all surfaces except those of recent upheaval. There must have

⁴ C. D. Walcott: 'Cambrian Geology and Palaeontology,' iii. Pls. 29-34. Washington, 1916. Smithsonian Institution. Many Cambrian trilobites have posterior spines of various morphology.

been miles and miles of foreshore, exposed between tides, where fishes, cut off in the mud, gasped air, until the water came over their gills again, and the undertow carried them back into the depths. But in fossiliferous times until the Devonian, there was little *dry* land; and there were no undisturbed shallow marshes, where water animals and plants could learn to do without water.

We said 'in fossiliferous times.' It is not fitting for one who is not a geologist to do more than touch very lightly on the problems of the Pre-Cambrian. But connected with them is an interesting consideration to which I would draw the attention of fellow-biologists. If we follow the American geologists⁵ in attributing organic origin to the graphites of the Grenville series at the base of the Laurentian—which are stated by Dawson to contain as much carbon as the whole American coal-measures, and with which we may class the graphite schists described by Geikie⁶ under the Scottish Lewisian, and the seven feet of so-called 'anthracite' found in Finland by Sederholm⁷ in the Jatulian, at least three miles under the Cambrian—I do not see how we can avoid the conclusion that there was vegetation growing in or about quiet landlocked waters, for many thousands of years, as long before the Cambrian as the Cambrian was before us. Among palaeontologists the view prevails that it is in such still landlocked waters that rapid evolution has always taken place. It seems impossible not to believe that a terrestrial flora, and a terrestrial fauna, must have been evolved in those favourable times and the long ages which followed, to be swept to destruction in the deluge that denuded the Torridonian. If so, we see in the succession of Cambrian and Ordovician fossils—the 'marine period' of the Palaeozoic, as Marr⁸ designates it—the development for a second time of a littoral from a deep-sea fauna; which fits closely with Walcott's conclusions on the Cambrian.⁹ And in the Silurian and Devonian we see the evolution of a terrestrial flora and fauna for the second time.

If all the Pre-Cambrian lands were swept by fierce and terrible torrents, marine organisms might nevertheless survive in the deep abysses of the sea, to recolonise later the still-vexed Cambrian shores. It is also conceivable that exceptional organisms might survive in the tranquil abysses of the high air, or on the occasional mountain-tops; and the fancy has struck me that such isolated survivors from the ancient sub-aerial population may conceivably be recognised in the progenitor of the Ordovician winged insects, and in the ancestor to Hugh Miller's conifer of the Old Red Sandstone.¹⁰

Leaving the geologists and botanists to settle for us the truth or error

⁵ C. Schuchert, Pirsson and Schuchert's Text-book, vol. ii, p. 545. New York, 1920.

⁶ A. Geikie, *l.c.* p. 890. ⁷ *Nature*, 1908, p. 266.

⁸ 'Principles of Stratigraphical Geology,' p. 149. Cambridge, 1905, University Press.

⁹ He believes that before the Cambrian there was an era, 'of unknown *marine* sedimentation between the adjustment of pelagic life to littoral conditions and the appearance of the Lower Cambrian fauna.' Quoted by Schuchert, *l.c.* p. 570.

¹⁰ Compare D. H. Scott, 1924: 'Extinct Plants,' p. 181. London, Macmillan.

In America the denudation before the Cambrian marks the 'third Great Erosion Interval.' The Grenville coal was before all these; Grabau (p. 203) puts Jatulian between the second and third.

of the premisses,¹¹ the argument does not seem without philosophic interest:—that if the 7-foot graphite bed in Finland be of organic origin, there may be a class or classes of terrestrial animals or plants which have breathed air two or three times as long as those which left the sea in the Devonian.

The Laurentian coal, if coal it be, must mark the climax of a long evolution in the seas of the still earlier Pre-Laurentian, and in that part of our history must come the primary advance which Church has rightly taught us to regard as the greatest step in evolution, the evolution of the flagellates. Church claims that, since protoplasm appeared, we may fairly estimate half the time elapsed as being required for the evolution of the flagellate.¹² If Dr. Church measures his time in years, the geological record seems difficult to fit; for the chaetopods, molluscs, crustacea and echinoderms of the Cambrian are clearly very old phyla. But the single step in evolution is not a year but a generation, and there may well have been as many generations of our ancestors before they became flagellates as there have been since we have been multicellular. If we have been 'higher animals,' averaging ten generations a year, for 1000 million years, then some 10,000 million generations may have brought us from jelly-fish to men. But 1000 generations a year would be a very moderate number for flagellates and pre-flagellates,¹³ so that 10 or 20 million years would give them as many steps in evolution, to make a flagellate from nothing, as it has taken us to build up a flagellate into that highest of all living creatures, a member of the British Association (Section D).

We are still lacking a satisfactory account of the early ocean in which those fateful 20 million or 200 million years were passed, and in which life began. I must relegate to a printed Appendix some arithmetical criticism which I have ventured to make on Professor Joly's theory of the sea. Resulting from that arithmetical discussion, I suggest as a working hypothesis for biologists that, since the Pre-Cambrian, there have been no variations in the mean salinity of the ocean so great as the difference between the salinity in the Mediterranean and in the North Sea.

The first ocean was more or less saline: it was also soaked with carbon-dioxide. In the air there was no oxygen, but nitrogen, much water-vapour, and carbon-dioxide in large quantities. Life is the history of high carbon compounds, in which every atom of carbon has been in a molecule of carbonic-acid gas. Volcanoes and springs have always been

¹¹ Prof. A. C. Pickering (*Geol. Mag.* lxi, 1924, p. 31) supposes the moon to have left the earth 700 million years ago. If we shorten this to 600 million it would account for the cataclysm, and from the ratio given by Jeffreys (*l.c.* p. 229) it would be 30 million years before the tides dropped to double their present height. But I am informed that the mathematical theory of the earth's period of oscillation makes a geological date for the moon's birth highly improbable. It seems from the maps conceivable that in Torridonian times the tide might have swept right round the Northern Hemisphere.

¹² A. H. Church, 1919: 'The building of an autotrophic Flagellate,' p. 4 (citing Naegeli and Minchin). Oxford University Press.

¹³ In the highly developed ciliate, *Paramecium*, Woodruff recorded 600 generations a year, but in bacteria Brefeld found two generations occur in an hour. Gray found 34 minutes to a generation in the trout's segmenting egg (1927, *Brit. Journ. Exp. Biol.*, iv, p. 315).

pouring into the air CO_2 from the bowels of the earth, coal-plants and calcareous animals have buried in solid form the carbon from many thousand times the quantity of CO_2 which we have now in the atmosphere; it is therefore probable that the alkalinity of the sea, and the dissolved calcium, have varied considerably from epoch to epoch. If all the surface of the globe were one continuous meadow, evenly producing a ton of hay an acre annually, I make out that in twenty-five years it would have fixed as much carbon-dioxide as there is in the atmosphere, and in 15,000 years it would produce as much free oxygen as we have in the world to-day. We see, therefore, that the advent of photo-synthetic protein in the ocean must itself have changed the physiology of the world very considerably, and that the change in conditions, after a million years' duration of the lowest form of life, rendered the world capable of supporting organisms which would have been impossible at the beginning of that age, and conceivably rendered it incapable of supporting ever again the first forms of life.

Of the possible genesis of the first form of life we heard from Dr. Allen at Hull. To-day let us take up the tale, in the warm Pre-Laurentian sea, with little fragments of protein lying in the sunlit waters. Each fragment is continuously receiving energy—whether from the sun, according to Professor Baly's theory of activation, or from some other electromagnetic source—and with that energy is building up the molecules of the surrounding solution into molecules of protein, so that the fragment grows.

The supply of energy is continuous, and the supply of solution is continuous, yet growth of the fragment of protein cannot be continuous, because *number* is discontinuous. A growing fragment contains 100 molecules of protein, presently it will contain 101, then 102. It may be a thousandth of a second, it may be an hour between the moment of attaining 100 and the moment of attaining 101 molecules, but with a constant supply of energy it will be closely the same interval after acquiring the 101st molecule and before the 102nd is added. Let us suppose that the interval has been 10 seconds. What will be happening during the next ten seconds before the molecules number 103?

The continuous supply of energy must in some form be stored in the 102 molecules until its total is adequate to compel the combination of the water, carbon, nitrogen, sulphur and the rest of it into the new 103rd molecule of protein. This stored energy is then spent in forming the combination, and for another 10 seconds the 103 molecules accumulate gradually a sufficient supply to force the combination of a 104th molecule. We cannot suppose that the molecules can store energy except by a change of atomic or electronic arrangement, nor that such change fails to affect their molecular volume. Expansion of molecular volume means storage of energy which is released on contraction; we may feel sure that even if the main storage of energy be in some other form, it will at least be accompanied by expansion in volume and surface. When energy is given up to form the new molecule, all the old ones will return to their original volume, and if their expansion was by more than one-hundredth of their volume, the whole fragment will contract.

A slow expansion while energy is being accumulated, a rapid but

smaller contraction when the new molecule is formed, so these fragments of protein pulsate steadily through the day. So they continue through the ages, while protein enters into new combinations, and the aggregate of protein molecules is replaced by a unit of protoplasm, still keeping the rhythm of saving up energy and making-a-molecule, saving up energy and making-a-molecule.

Now protoplasm in most organisms which we can study becomes altered at the surface which is in contact with water, by a change which is conveniently called 'gelation,' the protoplasm at the surface losing most of its fluidity and changing in other properties. In certain circumstances, such as increased salinity of the water, the internal fluid protoplasm will burst out through this gelled surface in fine threads, which either gelate in their turn or change into strings of drops.

I venture to suggest that the great evolution of the flagellate, which Church pointed out to us, accomplished in some ten thousand or hundred thousand million generations, was the formation of a permanent filament of protoplasm of which one side was more gelled than the other side, so that one longitudinal strip of the cylindrical outer surface is more elastic and therefore less easily extensible than the opposite strip. Let us suppose the gradual accumulation of energy causing, as before, a gradual increase in volume of the protoplasm; then the more easily extensible surface will swell, and therefore lengthen, and the filament will gradually bend. When the quantum of energy is reached which suffices for formation of a new molecule, every old molecule will suddenly lose its surplus energy and return to its old molecular volume, the distended surface will return to its old dimensions and the filament will straighten.

I have spent an appreciable part of my life watching the flagella on the living collar-cells of Calcareous sponges—*Grantia*, *Sycon*, *Leucandra*, and *Clathrina*. Their movement is nearly confined to one plane and is asymmetrical, being almost always with a faster beat to one side than to the other. There is a pause, a stroke and a counterstroke. Mr. James Gray pointed out to me that if the counterstroke be elastic, as I supposed, it should always take the same time, as compared with the varying time of the active contraction. This I found to be the case. At about $2\frac{1}{2}$ double vibrations to the second, the stroke and counterstroke are of equal duration; at higher frequencies the stroke is the shorter, as in a schoolmaster's cane; at lower frequencies the stroke is the longer, as in a fisherman's trout-rod. The broad features of the phenomena are therefore consistent with the hypothesis that the counterstroke is an elastic rebound.¹⁴

The apparent improbability of a lowly organised cylindrical cell, with an axial straight flagellum, having one longitudinal strip of the surface of that flagellum different from all the rest of that surface, disappears when we recognise that one longitudinal strip has a different history from all the rest of the surface. A collar-cell in a sponge is usually surrounded on all sides by six other collar-cells, of which one is its twin sister. Like all flagellates, including metazoan spermatozoa, collar-cells divide longitudinally. The details of this division were worked out very beautifully

¹⁴ See Appendix B.

by Miss Robertson and the late Professor Minchin¹⁵; and they showed that the little bead at the base of the flagellum, known as the blepharoplast, is the first thing in the cell to divide, and forms two daughter blepharoplasts which take the part of centrosomes and induce the division of the nucleus into two daughter-nuclei, followed by the division of the cell into two daughter-cells. In each of these daughter-cells the new blepharoplast grows a new flagellum. It will be seen that the part of the blepharoplast which was last in contact with its sister is, as it were, a healed wound, and the strip of flagellum which grows from this has therefore a different parentage from that which grows from the opposite surface of the blepharoplast, which is an intact part of the parent surface.

There is no nervous system in sponges, and no sign of nervous control of the flagella, either from the individual cell or from the community. The direction and timing of their beat is wholly uncorrelated, and though the frequency of two neighbouring cells generally approximates to equality it is not exactly the same. The frequency varies when the temperature and soluble contents of the water vary. Except in certain cases where a wandering ovum (*Grantia*) or pore-cell (*Clathrina*) is laid over a collar-cell, I have never seen a flagellum motionless in a cell which was not moribund.¹⁶ I believe the motion to be ceaseless, unconscious, and uncontrolled, a direct function of the chemical and physical environment.

What has this to do with the history of animals? Our ancestors were flagellates, or lower than flagellates, for as many generations as they have been anything else, for perhaps five or fifty times as many generations as they have been vertebrates, at least two hundred times as many generations as they have been mammals, and our ancestors were flagellates for at least five thousand times as many generations as they have been men. All those flagellate ancestors of ours passed their whole active lives in this continual rhythm of accumulating energy and building, accumulating energy and building, twenty or more to the second through the whole of their short lives. Do you believe we have forgotten that rhythm? I believe that all through our growth, from infancy to prime, we added our molecules to every unit of protoplasm, rhythmically, as our flagellate ancestors did. And when we have passed our prime, our units keep their rhythmic reconstruction; only now, because we are land-animals and must not grow any bigger for fear that our limbs should snap, the rhythm or the chemical change is readjusted, so as only each beat to add as many molecules as we use up between the beats. But the adjustment is not perfect, so that when we have done growing, our protein units do not keep absolutely constant—they lose a little each beat on the balance of gain and expenditure.¹⁷ So that as we grow older our muscles shrink, and our nerves shrink, and our cartilages shrink, and our brain shrinks, and we become what other people call 'senile'; and at length we die—a thing which none of our twelve thousand million flagellate ancestors ever did.

Incidentally, I believe that to that same metabolic rhythm, inherited

¹⁵ *Q.J.M.S.* 1910, vol. 55, p. 611; 1912, vol. 57, p. 129.

¹⁶ Cf. J. Gray, 1926: *P.R.S.*, B, xcix, p. 398, and G. H. Parker, 1910: *Journ. Exp. Zool.* viii, p. 795 (or 31); and cf. *Journ. Linn. Soc.* 1921, vol. xxxiv, p. 317.

¹⁷ *Proc. Linn. Soc.* 1925, p. 17; 1926, p. 19.

from the flagellates, we owe our sense of time; so that our appreciation of dancing, poetry, and music shows that we are still flagellates at heart.

How was the transition from flagellate to multicellular organism effected? And what advantage did it bring? We have seen that a flagellum beats continuously and that a flagellate divides longitudinally. We must now turn our attention to a third cardinal characteristic—that flagellates exude on their exterior a watery jelly which is sticky.¹⁸

It seems at first sight a trifling detail of natural history to mention that flagellates exude a transparent mucilaginous substance which coats them, thinly if they swim, and thickly if they stay still for it to accumulate. Yet to this one property is due, not only their first aggregation into multicellular masses, but the possibility of all the physiological developments in plants, sponges, and metazoa, of which up to the present day those masses have shown themselves capable. Church said that in the primitive unit of protoplasm the peripheral deposit of waste carbohydrate is a necessary condition of its metabolism, but culminates in the production of the timber-tree. I would add, that it culminates also in the production of the mammal.

That an adhesive surface will enable flagellates to cohere is obvious; this, with the repeated longitudinal fission of the cells, produces first the temporary cohesion of rapidly dividing monads, which are the product of the encysted flagellate, and are gametes—exactly comparable with those of the sperm-tassels of *Lumbricus*; where the asexually produced generation of the earth-worm is a flagellate, dividing longitudinally, and adhering to its brethren, so as to resemble a piece of floating columnar ciliated epithelium. In the earth-worm's spermatozoa, as in most flagellates, the coherence is only temporary and the ultimate product of the longitudinal division is a free-swimming gamete. But in many flagellates—in members of almost every group of flagellates—as a method of distribution the original products of division never separate, and with repeated longitudinal fission the swimming sheet of cells becomes larger and larger, and therefore swims faster. Almost always, however, it becomes convex on the flagellate side—possibly because there the continuity of the water-jelly surface is broken by the moving bases of the flagella—but there is clearly no *a priori* reason to expect surface tensions to be equal in the dissimilar flagellate and non-flagellate surfaces. The phenomena show that the surface tension of the flagellate surface is the less, so that it becomes increasingly convex, until the growing sheet of cells is bent round into a hollow sphere, such as we admire in *Volvox*, *Synerypta*, *Uroglenopsis*, &c.

Thus the properties of longitudinal fission and gelatinous exudation give rise in all flagellate groups to a secondary characteristic of the flagellates, their tendency to form hollow spheres bounded by a single layer of cells.

¹⁸ Church, *l.c.* p. 8, considers that because the supply of CO₂ is disproportionately large compared with that of the other ingredients of protein, there is a general excessive synthesis of CHO compounds, followed by their elimination on the periphery of the cell as mucilage or 'wall' deposits. See E. Bresslau, 1924, 'Neues über Tektin': *Verh. Deutsch. Zool. Ges.*, E.V. xxix, p. 91. He finds the slime on *Colpidium* to be mucin; see also Bresslau, 1924, *Senckenbergischen Naturf. Ges.* p. 49, and G. Lapage, 1925, *Q.J.M.S.*; also see *Q.J.M.S.* 1895, p. 22, and p. 14, Fig. (a).

These spheres we may perhaps call 'hilospheres,'¹⁹ because of the hilum or scar left at the point of ultimate closure, leaving the name 'blastospheres' for spheres produced by the secondary process of holoblastic segmentation in three Cartesian planes, which has been adopted by the metazoan zygote. This, like so much of the phenomena of embryology, must be regarded not as a repetition of history, but as a direct method of obtaining a result previously reached by a longer process. It is interesting that the zygote, both of the Calcarenean sponges and of the Ctenophora, clings to primitive flagellate longitudinal division up to the 8-cell stage, producing a crown or ring of cells strongly reminiscent of the 8-celled crown of the flagellate *Stephanosphaera* or of the 16-celled *Cyclonexis* or *Gonium*.

When a hilosphere has been closed, the mucilaginous secretion on the inner surface of the cells which bound it can no longer be washed away, and the interior cavity becomes filled with jelly. In sponges, the comparatively uniform diameter of the adult flagellate chambers in a given sponge indicates that they cease to grow when the hydraulic pressure of the water within them is equal to the static pressure in the interior of a bubble, which is of the diameter of the chamber and has the surface tension of its surface. That is, a collar-cell only divides longitudinally when it is pressed upon by its neighbours on either side, dividing against this lateral pressure. It is possible that a similar response determines the diameter of a closed hilosphere; inside it there is not only the pressure at which the jelly is secreted, but unless the cellular envelope be impervious there will also be osmotic pressure due to the jelly not being isotonic with the external sea-water. In the plasma of the frog's blood the osmotic pressure is about 3 cm. of water for each 1 per cent. of proteins²⁰; in the flagellate chambers of sponges I have published a calculation deducing the surface-tension of .35 C.G.S. units.²¹ This, in a hilosphere or blastosphere 60 μ in diameter, would be balanced by an internal pressure of 1.2 mm. of water. Therefore a percentage of .04 per cent. protein in the central cavity would produce equilibrium, the cells of the spherical wall would neither be pressed against each other nor dragged apart, and on the above hypothesis the growth of the hilosphere would cease.

It is interesting to note that, apart from any such hypothesis, if at any stage the cells of a blastosphere or hilosphere proceed to feed on the fluid in the segmentation-cavity and to withdraw proteins, carbohydrates, or salts, the osmotic pressure will be lowered. If the central fluid be made hypotonic as compared with sea-water²² then the internal osmotic pressure will be negative, and if the wall of the blastosphere be permeable to water it will be invaginated. If from the central cavity the cells of a blastosphere abstract soluble substances the blastosphere must be invaginated.

¹⁹ This word will not bear philological analysis; but it is convenient in length and sound.

²⁰ C. Lovatt Evans, 1925: 'Recent Advances in Physiology,' p. 148. London, Churchill. [See also Adair, 1925, *P.R.S.*, B. 98.]

²¹ *Q.J.M.S.* 1923, lxxvii, p. 306.

²² At a recent meeting of the Challenger Society observations were quoted showing that the urine and pseudo-cartilage of the sun-fish is each lighter than sea-water. I regret that at the moment of going to press the references are not to hand.

This is obviously more likely to take place where certain definitely digestive cells have been segregated in the wall of the blastosphere, as in the ontology of a metazoon.

With the completion of a closed cellular envelope externally flagellate and internally filled with jelly, we have now the possibility of any true sponge (excluding the hexactinellids) and of any metazoon. We scarcely note the mucilaginous exudation in free flagellates except when they cling together, though we observe it in the fixed forms as the investing jelly of the palmellar stage, or as the gelatinous 'houses' of choanoflagellates and others. But, enclosed in a hilosphere, it has now the potentialities of the intercellular jelly of the sponge parenchym, of the structureless lamella of the hydroid or the jelly of the medusa disc, of the semi-fluid which fills the segmentation-cavity in every larva and embryo. With slight modification it has become in us the jelly of our cartilage and the plasma of our blood.

The late Dr. Strangeways and others, who have cultivated tissues in vitro, have shown that living tissue, from almost any source except highly differentiated epithelium, when placed in a nutrient medium, will proliferate feathery cells into the medium until a network is formed of nucleate masses of protoplasm stretching fine processes into the delicate threads which join them.²³ That form of proliferation into a nutrient medium must have been inherent in the flagellate ancestors of true sponges and of metazoa. But we get a cobweb growth of similar form into *sea-water* in the flagellate *Dendromonas*,²⁴ and in the hexactinellid sponges, as described by Ijima.²⁵ We have no idea of the conditions which determine coalescence or independence,²⁶ but the 'buffy coat' of human blood, which is a measure of the agglutination of the red corpuscles, may be increased a hundredfold by some change in the constitution of the plasma, the nature of which is still the subject of surmise.²⁷ In true sponges, coelenterates, and trochospheres, we find the surface toward the water preserving the firm outline of an epithelium, while the surface toward the internal nutrient medium, as in laboratory preparations, proliferates into the segmentation-cavity feathering cells—named by the Hertwigs mesenchyme—to form the tissues of the organism. This is well shown in Baitsell's drawings of the segmentation-cavity in the chick embryo.²⁸

The exudation from the cell-surface, which our cartilage and ganglion cells have inherited from the flagellates, is the foundation of metazoan physiology and of metazoan morphology.

We must still ask, with what advantage did sponges and Metazoa arise in the Flagellate Sea of the early Pre-Cambrian? Among the photosynthetic monads we know that there were some which learnt the canni-

²³ *E.g.* T. S. P. Strangeways, 1924: 'Tissue Culture in Relation to Growth and Differentiation.' Cambridge, Heffer.

²⁴ Pascher, 1914: *Süßwasserflora*, Jena, Fischer; i. p. 95.

²⁵ 'Studies on the Hexactinellida,' Tokyo: *Jour. Sci. Coll.* xv, pl. 5, and *passim*.

²⁶ J. Gray (1926: *Brit. Journ. Exp. Biol.* iii, p. 167, quoting Galtsoff, 1925) has results allowing the deduction that coherence was only possible while the sea retained a certain acidity or after it had reached a certain salinity.

²⁷ C. Lovatt Evans, *l.c.* p. 8. ²⁸ G. A. Baitsell: *Q.J.M.S.* 1925, lxi, p. 571.

balistic habit of supplementing their own synthetic products by engulfing the spores of their neighbours or their fragmentary mortal remains. Some carried cannibalism so far as to give up altogether the colouring matter which in sunlight made carbohydrates out of their environment, living instead on carbohydrates and proteins formed by productive contemporaries.

These seceders formed many specialised groups, of which the choanoflagellates, like many of the much higher ciliates, adopted the policy of fixing themselves to the ground by their blunt ends, so that the flagellum made a current carrying the desired spores, which passed over the sticky body. For this function they changed the tractellar action of the flagellum (still preserved in sponge larvae) into a pulsellar action²⁹—a change which may be effected merely by lengthening the flagellum. Also, by means of the well-known transparent collar, they masked the part of the flagellum nearest the cell, where the motion is purely lateral and only drives the food away from the adhesive surface without assisting the current.

Where two choanoflagellates, side by side, drove their currents in the same direction, each reinforced the other and each cell obtained more food than when working alone.³⁰ Consequently choanoflagellates began to form colonies of various types. One, the *Proterospongia* of Saville Kent, has been hailed by all as marking a stage towards the evolution of sponges; but from this flat gelatinous crust it is very difficult to imagine the advantageous steps which led to an Olynthus supplied by intracellular pores; I would conceive the ancestor as a saucer-shaped *Proterospongia* colony fixed by a narrow base. I propose the name of *Porifera vera* for the sponges descended from this form, and, like it, having collar-cells based on interstitial jelly that contains other cells and is sheathed by other cells from the water. Such sponges, calcareous, horny, and tetractinellid, are contrasted with the *Porifera nuda*, the Hexactinellida, in which the collar-cells and most other cells are connected with each other by protoplasmic threads, but lie otherwise naked in the water. Hexactinellida must be descended independently from some colonial choanoflagellate like a *Codonosiga*, whose branches developed the faculty of anastomosis; and they are of a lower grade altogether than the true sponges. Living in the permanent currents of abyssal depths, they have not found necessary the hydraulic mechanism for a powerful outflow, which is found in every other group of sponges³¹; their hydraulic organisation is limited to a separation of the effluent from the afferent channels, but they have developed the secretion of cubic opal, on the skeleton crystals of which the network of their naked cells is extended across the current. They reproduce by ciliate gemmules: Ijima finds no gametes, but we are at liberty to imagine that the free-swimming gemmule may possibly produce them, as in *Volvox* and other flagellates.

Among the monaxon members of Dendy's Tetraxonida many sponges, of the general appearance of *Porifera vera*, have spicules which show, by a symmetry about three planes at right angles to each other, that they

²⁹ Geoffrey Lapage, 1925: *Q.J.M.S.* lxi, pp. 477, 495.

³⁰ *Q.J.M.S.* 1923, lxvii, p. 298.

³¹ *Ibid.* p. 312.

are of the cubic opal.³² I propose to call these *Orthogōnida*, with the four orders *Clavulida*, *Axinellida* (?), *Desmacidonida* and *Rennerida*.

In biology a new secretion seems one of the most difficult things to be produced in evolution, so that biochemists tabulate long series of allied respiratory pigments and chlorophyll derivatives: we inherit our visual purple from so far back that we still denominate as 'light' the limited range of vibrations which the sea transmitted to our flagellate ancestors,³³ and prove our descent from them by considering water perfectly transparent. Therefore it seems most probable that opal crystallising on the cubic system was only evolved once.

This principle indicates that the Orthogonida are probably descendants of Porifera nuda, and there is some evidence that in histology and reproduction they retain some resemblances to the Hexactinellida.³⁴ I suggest that they are descended (probably the four orders independently) from hexactinellids which found themselves in waters where the permanent current was inadequate. Thus they found it necessary to develop a hydraulic engine generally similar to that developed, probably independently of each other, by each of the three orders of the Porifera vera.³⁵

It is agreed by all that the main groups of sponges were developed before the Cambrian. And since Porifera nuda and Porifera vera arose from differing forms of Choanoflagellate colony, we may suppose that in the Flagellate Sea we had at least these two strains of sponges, and possibly the four main forms of skeleton; though possibly the slime of *Halisarca* and the horny sponges, and the three forms of crystallising secretion, may have only been developed for defence, when Metazoa arose and began to feed on sponges.

For of metazoan animals in the Flagellate Sea there were none. All the choanoflagellates, all the sponges, and all the intermediate ancestors were *microphagous*, that is, evolved to supply their component monads with food in the form of minute particles, such as spores, very small protista, and minute fragments of decayed protista. So they fed in the Flagellate Ocean of the early Pre-Cambrian age, and so they feed to-day.

³² Cf. *Nature*, 1925, vol. cxv, p. 299; and G. C. J. Vosmaer, 1886: Bronn's 'Porifera,' p. 473. The chelae of *Merlia* and *Melonanchora* have each three planes of symmetry at right angles to each other. The spicules of *Reniera* and *Chalina* are absolutely symmetrical end for end, as are the birotulae of *Ephydatia*. This is extremely unlikely in spicules formed of tetraxon opal, where one end corresponds to bases of tetrahedra, and the other to their apices.

³³ Church, *l.c.* p. 6.

³⁴ H. V. Wilson, 1891: *Journ. Morph.* Boston, v. p. 511 (*Esperella*); and 1894, ix. p. 277. Kirkpatrick, 1911: *Q.J.M.S.* lvi, pl. xxxii. (*Merlia normani*—note collar-cells); J. Cotte, 1903: Thèses présentées à la Faculté des Sciences de Paris. Lille; p. 428, 'chez les Clionides une disposition rappelant la structure trabéculaire des Hexactinellides'; Topsent (on the flagellate chambers of *Cliona*), *Arch. Zool. Exp.* (2) V bis.

³⁵ As to the relationship to each other of the Porifera vera, I have published remarks on the similarity of the outer cells of horny sponges with those of *Calcarea* (*P.R.S.* vol. 52, p. 134), Dendy and Row have noted the resemblance between the canal system and collar-cells of *Oscarella* and those of a calcareous sponge (*Leucettusa*, *P.Z.S.* 1913, p. 738), and I may add that the collar-cells of *Oscarella* and *Clathrina* are strangely alike.

Grant named the group Porifera³⁶ from the pores of their external surface, through which all water enters to the collar-cells. We know now that in most sponges these pores represent only the most exterior of two, three or more filters, interposed to prevent access of larger bodies than those which the collar-cells ingest. There is no sponge into which the sponge current can carry a body larger than a frog's blood-corpuscle, and in most the entrance pores of the flagellate chambers will not admit a particle of one-third of this diameter.

Stomached animals are formed with a cavity into which many cells pour a secretion, which thus digests up to fragmentation portions of organic matter too large to be ingested by any single cell. In the early Flagellate Ocean there were no particles of organic matter too large to be digested by a single cell, and therefore stomached animals did not arise until they had multicellular algae and sponges on which to feed. The sponges are therefore the more ancient group, and have had little need for change, except for defence against animals. Few of the changes which have taken place in mollusc, crustacean, or vertebrate, affect their life; except as the abundant reproductive products of the Metazoa provide more food for the Porifera. The secondarily assumed microphagous habits of Lamellibranchs and Tunicates do not prevent the sponges, with their longer history, from flourishing on an oyster-farm and damaging the oysters. When we watch the currents of a sponge, or under the microscope watch its collar-cells feeding, we are seeing, unchanged, what took place in the seas of the Pre-Cambrian more than 1000 million years ago, when the inhabitants of the ocean were flagellates, low algae, and sponges.

How did animals come? Embryologists tell us of the blastula—a common form of motile spore-bearer among flagellates, never, so far as I know, observed to feed except by photosynthesis. They tell us of a gastrula, but the laws of viscous motion make it clear that the free-swimming gastrulae we observe as larvae could never earn their own living, since the stream-lines would carry every particle of food outside the cone of dead water which is dragged behind the gastrula mouth. Creeping planulae or gastrulae might pick things up, but as a predatory organism a free-swimming planula would seem a most ineffective and unarmed buccaneer,³⁷ and it is not surprising that in nature no such creature has ever been known as an adult, and no planula or gastrula larva has ever been recorded to have taken into its endoderm a single particle of food.

In the embryology of sponges I am convinced that the blastula, gastrula and planula have no historical significance, other than the fact that flagellates are in the habit of distributing themselves by flagellate aggregates, often of the blastosphere form. For the rest, the amphiblastula of *Sycon* and the planula of *Axinella* are merely convenient ways of arranging in the motile aggregate the segregated elements of the future tissues. The embryology of animals is held by those who study it to be more significant

³⁶ Grant called them first Porophora (1825, *Edin. Phil. Journ.*), then Poriphora ('Outlines of Comparative Anatomy,' 1835, p. 5), and Porifera in 1855, Todd's *Cyclopaedia*, *vide* Vosmaer (Bronn, p. 52). Hogg objected (1839, p. 399 footnote) that he had used the word Porifera first in 1827 for an order of corals (*Cellepora*, &c.).

³⁷ So also E. W. MacBride: 'Text-book of Embryology,' p. 99. London, 1914, Macmillan.

than this ; if so, in view of the fact that Enterozoa arose later than sponges, it might seem easiest to guess that Enterozoa arose from Porifera vera, and that the blastopore which persists as an anus in Echinoderms recapitulates the osculum of a *Sycon*. This does not oppose the view that the keyhole blastopore of molluscs or *Peripatus* may recapitulate the siphonoglyphs of a coral³⁸; but I suggest that if there be recapitulation in the gastrulæ, it is recapitulation of a comparatively high stage of development (as Sedgwick supposed), and that the cavity into which the blastopore opens is in either case a cavity which was lined with the embryologically outer layer of the ancestor recapitulated. Gill-slits, the posterior position of the blastopore, enteric diverticula, the calcareous spicules of Echinoderms and the embryology of the Ctenophora³⁹ offer great temptations, but I will not waste more of your time on the easy elaboration of the hypothesis that Metazoa, or some of them, are descended from sponges.

When Metazoa arose, the world contained Protista, Sponges and Algae. It seems more easy to imagine the evolutionary steps which would convert a *Sycon* into an Enterozoon than those which would build one up out of unicellular Protozoa, or convert into a beast of prey the green and innocent *Volvox*. That must be decided by those who study the Metazoa and their embryology. As a student of sponges I entirely reject the view that there is any common ancestor, above the flagellate monad, from which the two branches of Parazoa and Metazoa have diverged. If the hypothesis be acceptable that Parazoa were parents to Metazoa, the word 'animals' may still be used phylogenetically to include alike the Enterozoa and the sponges from which they sprang. If those who study Metazoa reject this hypothesis, the MICROPHAGA must be recognised as constituting a third kingdom of multicellular organisms, specialised for the intracellular digestion of living organisms under 5 μ in diameter.

APPENDIX A.

Salinity of the Ocean.

Joly has given his opinion, as a chemist, that the original boiling and superheated ocean only dissolved from the magma one-ninth the percentage of chlorides which our ocean now possesses. Professor Joly assumes that, ever since that primeval ocean, sodium brought down by the rivers has been steadily accumulating in the sea and progressively increasing its salinity. This assumption the man in the street may criticise.

About half the sodium in the rivers comes from sedimentary rocks: where did the sedimentary rocks get it from, if not from the sea under which they were formed? When a portion of the ocean is landlocked and evaporated, as began 5000 years ago over the Caspian plains, the distilled

³⁸ Adam Sedgwick: On the origin of segmented animals and the relation of the mouth and arms to the mouth of the *Coelenterata*: in *Proc. Camb. Phil. Soc.* vol. v, 1884. The historian may care to know that Sedgwick gave this theory to us in his lectures in the Michaelmas term of 1882, I think two months before he read his paper on *Peripatus* at the Royal Society.

³⁹ Besides the segmentation of the ovum in *Berœe*, *Idyia*, &c., see Mortensen's account of *Tjalfjellia*, 1912, quoted by MacBride, *Enc. Brit.* vol. 30, p. 973.

water is returned to the ocean, but the whole of the salt it contained is withheld in the land, as we see in the New York salt-wells, or the shores of the Dead Sea. Landlocked seas have provided a great volume of our sedimentary rocks; but, even when formed on a sinking continental shelf, a sandstone would take down from the ocean enough sea-water in its interstices to leave it with .25 per cent. of sodium when the water was evaporated. If we call the sodium in the sea and in the land above sea-level the 'available' sodium, of this quantity 82 per cent. is in the sea, about $8\frac{1}{2}$ per cent. has been in the sea and is now in sedimentary rocks, and only about 10 per cent. is in igneous rocks above sea-level, and has presumably never been in the sea. Geologists tell us that we are at the climax of a period of maximum elevation; therefore much salt has been imprisoned in the land and the present salinity of the sea must be a minimum. If we take the extreme hypothesis that, at the next period of maximum denudation, a quantity equal to one-sixth of the mass of the present land will be denuded without compensation, and *all* its sodium dissolved in the sea, it would only increase the specific gravity of sea-water from 1.026 to 1.027. If it be true that in 1500 million years igneous rocks have supplied eight-ninths of the salt of the ocean, a mass equal to all the igneous rocks now above sea-level must on the average have been erupted and dissolved every 200 million years, which is about the age of the Permian. Yet most of our volcanic rocks are far older than the Permian.

From Murray's calculations (1888, *Scott. Geog. Mag.* iv, 1, *vide* Mill, 1892, 'Physiography,' p. 191) the volume of the ocean is 14 times that of the volume of the land above sea-level. Taking the specific gravity of the land as 2.6 times that of the ocean, the mass of the land in tons is therefore $\frac{1}{5.14}$ that of the ocean. Holmes (*l.c.* p. 37) estimates 'igneous and other crystalline rocks' as roughly forming a quarter of the land. From descriptions of Canadian and Scandinavian geology one would guess that half of these are sedimentary, but to give Professor Joly the largest figure possible, we will assume that a quarter of the mass of the land is volcanic. Taking Holmes's figures for the percentage of sodium, we find therefore:—

	Mass (taking mass of the ocean as unity).	Per cent. sodium.	Sodium expressed as per cent. of the ocean's mass.	Sodium expressed as per cent. of the ocean's sodium.
Sea	1.00	1.08	1.08	100
Volcanic Rocks046	2.85	.131	12
Sedimentary Rocks139	.81	.113	$10\frac{1}{2}$

Therefore to provide eight-ninths of the sodium in the sea would require $7\frac{1}{3}$ times the mass of volcanic rocks now above sea-level. Also a sixth of the whole existing land would yield 3.8 per cent. of the sodium now in the sea; and, supposing that the sodium yielded were accompanied by its proportional chlorine (on which see Jeffreys, *l.c.* p. 71), magnesium, lime salts, &c., since the existing sea of sp. gr. 1.026 contains 3.4 per cent. of salts, these would be increased to 3.53, and the specific gravity to 1.0270.

As to included sea-water, we may take from Molesworth's Engineering 'Pocket-Book' (1917, p. 99) the interstices of pounded sandstone or of gravel as 34 per cent. of the total volume. Therefore in a cubic metre of this the sandstone would weigh 1500 kilogrammes, and the sea-water 350 kilogrammes, containing 3.8 kilogrammes of sodium, which would amount to .25 per cent. of the weight of the consolidated rock when the water had evaporated from the warm lower strata.

[Schuchert, in his 1924 edition, p. 133, calculates that igneous rocks sufficient to supply the salt of the ocean would cover all continents to the height of one or two miles. Possibly four-fifths of its salt reached the ocean in Pre-Palaeozoic erosion.]

APPENDIX B.

Some Numerical Data of Flagellar Motion.

In the active flagellum of *Grantia compressa* the longitudinal extension of the convex side as compared with the concave side must be in the ratio $\frac{19}{9}$ to produce the observed radius of curvature (about 3.5μ)⁴⁰. Assuming the length of the concave side constant, this would mean an average extension approximately in the ratio $\frac{1.9}{1.8}$. If this were the passive result of an increase in volume, as in the elementary theory suggested in the text, and if the diametral expansions were in the same ratio, then the indicated increase in volume would be in the ratio $\frac{7}{6}$.

But it was pointed out to me by a biologist at Plymouth, working on spermatozoa, that their right-handedness of motion indicates that the molecules of the flagellum are orientated with length parallel to its axis. It seems possible, therefore, that the unstable molecular strain which causes the flexion may be accompanied by an addition only to length of the molecules. It is impossible to assert definitely that a change of width from $.4\mu$ to $.44\mu$ would be recognisable in the retinal image, but my own belief is that in a slowly moving flagellum such a change in width would have an appreciable optic effect, and that in the flagella which I watched there was no increase in width of 10 per cent.; though as to 5 per cent. one would have no strong opinion, and as to 2 per cent. none at all.

It will be noted that the diameter of the flagellum can only contain some 40 to 80 protein molecules, and that of the flagellum of a minute flagellate cannot contain more than a quarter of this number, so that the true theory of flagellar movement must be simple.

The conception of one meridian of the flagellar skin being importantly more or less extensible than the rest was suggested to me by Sir W. B. Hardy; but he has no responsibility for the treatment of his suggestion.

The wave of contraction generally passes up the flagellum of *Grantia* with a velocity of $25\mu \pm 5\mu$ per second, but was observed with velocity over 100μ s. I concluded from other data that it is probably 200 to 500μ s. in healthy life, and that about 25μ s. is a minimum, so that if this cannot be attained, transmission does not take place. I computed the work done on the water per double stroke to be of the order of 1×10^{-10} C.G.S. units, with 5 vibrations per second. Healthy frequency (*Q.J.M.S.* 1895, p. 17) is probably nearer 20 vibrations per second.

⁴⁰ Internal radius.

APPENDIX C.

PROPOSED CLASSIFICATION OF SPONGES AND SUGGESTED GENEALOGY.

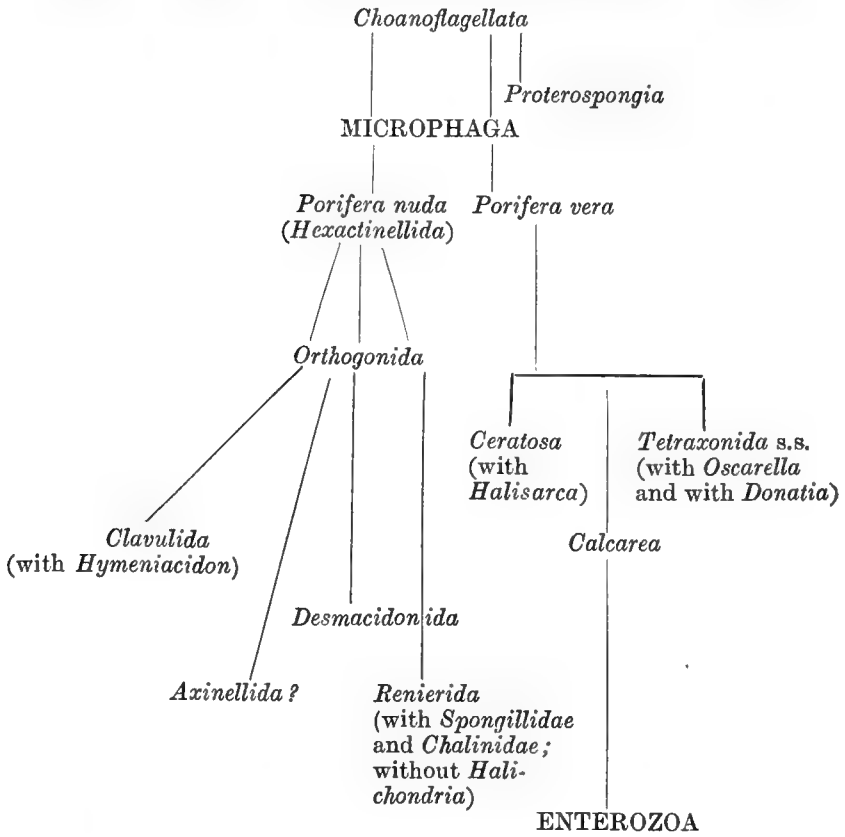

Orthogonida are defined;—Sponges resembling *Porifera vera* in hydraulic system, but having spicules formed of opal crystallising obscurely on the cubic system. Macroscleres of monaxon facies.

SECTION E.—GEOGRAPHY.

SOME PROBLEMS OF POLAR GEOGRAPHY.

ADDRESS BY

R. N. RUDMOSE BROWN, D.Sc.,

PRESIDENT OF THE SECTION.

SINCE the last meeting of the British Association at Leeds, thirty-seven years ago, the whole meaning of geography has changed. The purely empirical stages of the collection of data have largely given way to the higher stages of interpretation and explanation, and these in their turn have called for re-examination of the facts by the use of more accurate methods. An even greater change is the important place which geography has won in education. Nothing could be more striking than this advance in a generation or two unless it was the former neglect of the subject; one might say the entire omission of any geographical teaching in any grade of education—an almost incredible defect in the training of youth at a period of rapid imperial growth and consolidation. The battle is not yet won, but even if some of the universities of this country, which move but slowly, do not give geography the place it merits, it has at least a foothold in all. Geographical research and serious geographical publications have also shown an increase in recent times, though the output in this country is far too small. This, however, is neither the time nor the place to dwell on the educational side of geography. I recall these developments only because the present year has seen the passing of one who will always be associated with geographical work during the last half-century, and especially the rise of geography to a place of importance in the universities and the scientific world. Sir John Scott Keltie was one of the pioneers of geographical education, and as editor of the *Geographical Journal* and for many years recorder and secretary of Section E took a leading part in the advancement of exploration and the spread of sound geographical knowledge and research. The present position of geography in this country is largely a monument to his untiring labour, enthusiasm and tact.

Geographical thought of to-day shows a growing tendency to lay more stress on the human interests of the subject than it did of old. So far as this leads to a broadening of the outlook in what was formerly known as economic geography, with its somewhat narrow standards of the bourse and market-place, the development is all to the good. The humanising of the subject has done much to rob it of aridity and, by widening its scope, to bring it into close touch with other aspects of the study of man. It is a good thing for the growth of knowledge when barriers between allied subjects break down on a ground common to

both. These trends in human and social geography are to be welcomed, but at the same time there is a tendency to forget that our geography must be founded on a knowledge of the surface features of the earth. The physical factors must be thoroughly understood if the superstructure of human and social geography is to have a sure foundation. This foundation can be best laid in personal experience of earth, air and water. In other words, travel is an essential part of the training of the geographer if his work is to have any reality. The complexity of geographical values can never be gauged by any mere statistical presentment of the facts. The experience of the world that is necessary to the equipment of the geographer must be gained not merely by travel in densely populated lands, where the modern applications of science do so much to protect man from actual contact with the factors of climate, the influence of land forms and the effect of biological distributions, but of travel by sea and in empty lands and of practical experience in exploring the natural phenomena and occurrences, of real contact with the raw materials of geography, in order to learn the elements of the science at first hand. The scientific no less than the humanistic aspects of geography must be learnt by personal observation. The geographer who depends solely on maps will never understand his subject or be a source of inspiration to others. The best map is a poor substitute for reality. A year of personal experience of nature is worth the whole of a university course as a foundation of geographical study.

In selecting for the subject of my address some of the problems of polar geography I have been moved by a twofold reason. First, these problems come near to my interests by personal experiences, and I think that in a comparative lull in polar exploration in this country it is well to take stock of the problems that still await solution, and secondly, I feel that modern geographical thought, with its stress on the humanistic side, is tending to overlook the polar regions in spite of their wide geographical interest. They offer an incomparable field of observation for all sides of pure geography. From the many problems I can select only a few of importance.

The Tasks of Exploration.

To turn first to the Antarctic, there are certain fundamental problems in physical geography—problems of the nature of those which in other continents were solved several centuries ago. The broad features of the map of Antarctica are not built on ascertained fact so much as on intelligent guesswork.

The existence of an Antarctic continent is still based on circumstantial evidence, and until more than some 5000 miles of its coastline, or only about 35 per cent. of the total length, are known, direct evidence of Antarctica will be lacking. It is not a little remarkable that all the exploration of the twentieth century has merely modified the probable outline of that continent as it was predicted by Sir John Murray in 1886. He had little but the reports of Ross, d'Urville, Wilkes, a few sealers and the *Challenger* to go on, and, mainly on circumstantial evidence, he built his Antarctic continent. The one considerable change in that map has been the curtailment of the Weddell Sea and the removal of its

southern extremity some four degrees north of Murray's position in lat. 82°S . But that southward prolongation of the Weddell Sea and Atlantic Ocean at the expense of Antarctica was based solely on Ross's mistaken sounding of 4000 fathoms, no bottom, in lat. $68^{\circ}48'\text{S}$., long. $12^{\circ}20'\text{W}$.

Most of the Antarctic 'lands,' and certainly nearly all those that may be classed as key positions to the coastline of Antarctica, date from last century, some of them from a hundred years ago. Coats Land, Wilhelm Land and Oates Land are among the few exceptions. Enderby Land, the one certain or nearly certain land in over 3000 miles of hypothetical coastline, has never been seen or seriously searched for since Biscoe found it in 1831. It should be the base of an expedition that is prepared to work westwards. Heavy ice congestion so far found by all vessels that have tried to push south between Enderby Land and Coats Land, suggests that this stretch of coastline will have to be put in by sledge journeys along the edge of the ice cap. The western shores of the Weddell Sea are another ice-girt region which no ship has been able to penetrate, a region of dangerous ice pressure. Here, too, the advance must be by land journey, but it should be relatively simple, since accessible bases are known in Oscar Land and adjoining parts of Graham Land. Lastly, there is the great gap south of the Pacific between Charcot and Edward Lands, which leaves ample scope for an attack from both ends. A minor problem in the outline of Antarctica for an expedition based on Edward Land is the determination of the eastern side of the Ross Sea and the elucidation of Amundsen's sighting of land to the south of Edward Land, the appearance of land which he called Carmen Land.

But even more important than the discovery of the 'missing' stretches of the Antarctic coastline—a mere matter of descriptive geography—is the explanation of the structure of the continent and its former connections with other lands of the Southern Hemisphere. The problem is made more difficult of solution by the immense covering of ice that completely hides the underlying rock in most parts. Detailed exploration has so far concentrated on the two more accessible coasts of Antarctica, those of Graham and Victoria Lands. In fact, one might reasonably argue that there has been too great a concentration of interest on those coasts, on the part of well-found expeditions, to the neglect of unknown or little-known areas more difficult of access but promising more striking discoveries. That has been due, no doubt, to the one, Graham Land with its islands, projecting northward into open sea and lying near civilised lands, and the other, Victoria Land, offering the most promising point of departure for sledge journeys to the Pole. However, now that the South Pole has been reached, the temptation to focus effort on the best available base for that undertaking has gone, and the explorer's energy of the future is more likely to be expended in directions more profitable to the advancement of knowledge.

Graham Land, for we discard the awkward title of West Antarctica, and Victoria Land, or more strictly South Victoria Land, are both regions of lofty mountain ranges, but apparently of contrasted structure and diverse origin. The ranges of Graham Land, often called the Antarctic Andes, in stratigraphy and structure as well as in their eruptive rocks, bear so close a resemblance to the Cordilleras of South America that there

can be no reasonable doubt that they were at one time connected and are in fact disunited parts of the same foldings. Nor does it appear doubtful, any longer, that the line of former continuity can be traced by a submerged ridge on which stand relics of the chain: in the South Orkneys, the volcanic South Sandwich Group and South Georgia, extending in a great arc between Trinity Land and Tierra del Fuego and sweeping well to the east of Drake Strait. There is no doubt of this line of connection, but we are still uncertain if South Georgia, and even more so, if the Falklands are really fragments of the arc or relics of a lost South Atlantic Land.

The Antarctic Andes, or Southern Antilles, have been traced south-eastward but lost sight of at Alexander Island and Charcot Land, which in all probability are parts of the same formation. The great problem of the Antarctic is what happens to other ranges. On the opposite, or New Zealand, side of the Antarctic the great fault ranges of Victoria Land show little if any resemblance in structure and origin with the Antarctic Andes. A great horst capped with horizontal layers of sandstone, probably of Permo-Carboniferous age, is associated with much evidence of volcanic activity, and seems to rise from a great peneplain of crystalline rocks which underlie the whole of that side of the Antarctic ice-sheet.

The structure of the Victoria Land edge of the Ross Sea is reminiscent of Tasmania and eastern Australia, and the suggestion of former continuity across the Southern Ocean receives further support from our knowledge of submarine relief between Antarctica and Australia, especially the work of the *Aurora* Expedition.

The relationships between Antarctica and South Africa are still very obscure since the African quadrant of the Antarctic, both by land and by sea, remains one of the least explored parts. It will prove a fruitful area for an expedition to tackle.

It is unnecessary to enter into the details of the arguments in geomorphology bearing on the relationships of the two contrasted sides of Antarctica. I have recently expounded these at greater length elsewhere.

Only further exploration can solve the mystery. We must go and see if we want to know. But it may be of interest to state the possible solutions.

One suggestion is that the horst of Victoria Land is continuous with the Antarctic Andes. Certainly the direction of the Maud Mountains to the south of the Ross Sea supports this view, and evidence of great faults bounding the Andes may show that those ranges after all are not entirely different in nature from the ranges of Victoria Land. A second suggestion is that the Antarctic Andes reappear in the Ross Sea in the old crystalline rocks of King Edward Land—which as yet are but little known—and that these were once continuous with the folds of New Zealand. If this be true, the ranges of Victoria Land and the Maud Mountains probably swing across to Coats Land and may cause those vague shadowy shapes that a few of us who have seen Coats Land believe to exist in its far interior. Nothing is known at first hand of the structure of Coats Land, but rock fragments dredged in the Weddell Sea, and presumably derived from Coats Land, suggest a closer relation with Victoria than with Graham Land.

In any case, it looks probable that our knowledge of Antarctica confirms the growing belief that the Pacific basin is girdled by a ring of fold mountains marking the course of a system of geosynclines. The remains of the borderlands of this Pacific geosyncline may possibly be found in small islands in that mysterious ice-bound region to the north of Edward Land which no ship has been able to penetrate.

In the face of these great problems in exploration, it seems trivial to speak of the minor ones that await solution in the south. Reference, however, may be made to the desirability of measuring an arc of meridian in a high southern altitude. F. Debenham has pointed out how Victoria Land lends itself to this task.¹ I have not time to dwell on the problems of meteorological exploration and can only point out that much has yet to be done in explaining the peculiar Antarctic blizzards which rank among the fiercest winds on the face of the globe. G. C. Simpson has given an explanation of these in the Ross Sea, but are the blizzards of Wilkes and Coats Lands, which occur under different topographical conditions, amenable to the same explanation, or has W. H. Hobbs found the solution in his theory of strophic winds associated with glacial anticyclones, a theory which he applies also to Greenland where he is at present investigating it?

Recent observations in North-East Land, Spitsbergen, confirm the association of this general air circulation with a dome of ice-covered land, but, as Sir Napier Shaw, L. C. W. Bonacina and others have pointed out, we require another term than anticyclone for this state of affairs since the high pressure is only a shallow surface effect resulting from local conditions, and not a true anticyclone developed as the outcome of general atmospheric circulation independent of local topography. Even the qualification of 'glacial' does not remove a possible confusion of ideas. The supply of cold air from polar regions towards lower latitudes appears to be independent of pressure inasmuch as the winds are katabatic winds flowing down the slope of high land. It is orographical relief and not pressure which supplies the driving force of the cold air currents of the polar front.²

A further important meteorological problem, with strong geographical bearings, is the alimentation of the ice-sheet. We know that it is wasting by the calving of icebergs, by surface ablation, and other processes, and that it has shrunk considerably since its Pleistocene maximum, but we are at a loss to explain satisfactorily how the precipitation in the heart of an anticyclone can ever have been sufficient to allow such an ice-sheet to grow. There is every reason to believe that during the great Ice Age ice-sheets did not develop over the Arctic islands of Canada or over most of Siberia. The temperatures were low, but moisture was insufficient. And yet in the Southern Hemisphere the ice grew in the heart of a vast high-pressure area.

¹ *British Antarctic Expedition, 1910-13. Report on Maps and Survey, 1923.*

² W. H. Hobbs, *The Glacial Anticyclones* (1926). A valuable symposium on Arctic meteorology is the collection of papers read at the first meeting of the International Society for the Exploration of Arctic regions by Airship, published in *Petermann's Mitteilungen, Ergänzungsheft* 191 (1927). A chart shows the route of the proposed expedition and the location of observing stations.

Still another problem is that of oscillation of climate as expressed by varying amounts of sea-ice and variations in the intensity of currents. R. C. Mossman and others have shown that there is a correlation between certain Antarctic records and those from places in the Northern Hemisphere. There seems to be every likelihood that before long general weather forecasts of real value will be possible for some months ahead.³ At Buenos Aires, for example, the high correlation coefficient of $+0.88$ is reached when the summer rainfall there is correlated with the temperature of the South Orkneys for the winter that began three and a half years earlier. In fact, statistical correlation indicates that a very cold winter at the South Orkneys will be followed after an interval of three and a half years by a drought over the Argentine cereal belt; a very mild winter, after the same interval of time, by bountiful rains.

Lastly, there is great need of oceanographical work in high southern latitudes. This branch of research has been overlooked by most expeditions in their hurry to reach their southern bases. Certainly in the tempestuous seas of the fifties and sixties of southern latitude it is uncomfortable and trying work and exasperating in delays and loss of apparatus. The employment of echo-sounding should, however, make it both easier and more accurate.

There has been much careful and intensive work in the Antarctic during this century, indeed since the voyage of the *Belgica*, but it has merely touched the fringe of what there is to be done. The recent work of the R.S.S. *Discovery* in the seas to the east of South Georgia should fill gaps in existing knowledge of the Southern Ocean, but details are not yet available.⁴

Antarctic expeditions are costly, far more costly than expeditions to the Arctic. It is unlikely that an impoverished Europe will be able to find the necessary funds for years to come. We must look with hope towards the great new nations of the Southern Hemisphere, some of whom have already shown a marked interest in the Antarctic. It will be a sad day when man is so free from curiosity about this earth that the last mysteries of its surface are not probed because the task demands enthusiasm and money.

No pioneer problems of equal magnitude await the explorer in north polar regions. There is small likelihood that any new land of importance remains to be discovered. There is certainly no 'polar continent.' However, there are gaps to be filled. Nicholas Land, found by the Russians to the north of the Taimir peninsula in 1913, has still to be investigated. Its full extent and its relation to other Arctic islands are unknown. North-west of it the Arctic Ocean has never been penetrated except by the drifting *St. Anna* in 1912-14. We hope that Russian investigators of the coast of Siberia will include Nicholas Land within their scope of work.⁵

³ 'Southern Hemisphere Seasonal Correlations,' R. C. Mossman. *Symons Meteorological Mag.*, 48, 1913; and 'The Climate and Meteorology of the Antarctic and sub-Antarctic Regions,' R. C. Mossman, *Jour. Scot. Met. Soc.* 1918, pp. 18-29.

⁴ 'Discovery' Expedition. First Annual Report, H.M.S.O., 1927.

⁵ For the latest map of the Russian Arctic coasts, see 'The Russian Hydrographical Expedition to the Arctic,' N. A. Trausche, *Geog. Review* (New York), No. 3, 1925.

The Beaufort Sea to the north of Alaska and to the west of the Canadian Arctic Archipelago, across which Amundsen, Ellsworth and Nobile made their daring flight in 1926, has never been penetrated. Its exploration is required in the interests of Arctic oceanography, and the mystery of Peary's Crocker Land should be finally solved. Tidal observations of the *Maud* Expedition off the Siberian coast have been shown by H. U. Sverdrup to negative the probability of extensive land to the north of Bering Strait and Alaska. Yet the five hours' retardation of the tidal wave in reaching Point Barrow, Alaska, from the north, compared with its time of arrival at the De Long Islands, north-east of the New Siberian Islands, indicates the possibility of small islands in the Beaufort Sea or more probably merely the existence of shallow water.⁶

In addition to Crocker Land, several elusive lands have been reported in the Arctic Ocean, and from time to time have found their way on to maps, in most cases only to disappear when confirmation of their existence was not forthcoming. Experience has shown that visibility plays strange tricks on the observer in polar regions. A snow-covered land may merge completely in the background of sea-ice and grey sky or an unsuspected local fog bank may blot it out at a few miles' distance. No polar land can be said to be disproved until its site has actually been sailed over. And even then one may ask, Was the reputed site a true one? Its position may have been guessed from a single long-distance sight, and guessed perhaps on a basis of faulty observations. The drift of *Fram* and the voyages of *Taimir*, *Vaigach* and *Maud* may be held to have disposed of Sannikov's Land to the north of the New Siberian Islands. Keenan Land to the north of Alaska has also gone. There is little probability of Andrejev's Land being a reality, but no ship has yet penetrated the area of sea where it was reported to lie (1763) to the west of Wrangel Island, in about the meridian of 170° W., between lat. 72° and 73° N. There between the tracks, on the south of *Taimir* and *Vaigach* and on the north of *Jeannette* and *Maud*, occurs a region of heavy impenetrable pack. Kellett's Plover Land, a degree or two north of Herald Island, north-north-west of Bering Strait, was removed from the map as a result of several later voyages of vessels that sailed over its reputed site and saw no land. But a shadow of doubt has fallen on these corrections since, in 1914 from the high eastern end of Wrangel Island, the appearance of land was noted on several days away in the east-north-east beyond Herald Island in an area of the sea where the water on the continental shelf is known to be very shallow. This appearance was given the name of Borden Land and may, if it really exists, be the long-lost Plover Land. Inaccuracies in latitude and longitude are easily made in hasty observations in high latitudes.⁷

An even more alluring mystery can be solved only by the exploration of that part of the Arctic Ocean between Spitsbergen and Franz Josef Land from lat. 80° to 84° N. There is no record of a ship traversing it, and

⁶ 'The Tides on the North Siberian Shelf.' H. U. Sverdrup, *Journal Wash. Acad. Sciences*, 16, pp. 529-540, 1926.

⁷ 'Plover Land and Borden Land,' V. Stefansson, *Geog. Review* (New York), April 1921. It may be noted that Keenan Land is the only one of these doubtful lands that Stieler retains in his most recent Nordpolar map.

there is more than one report of high land seen to the north-east of the Spitsbergen group. This, if it exists, is not Giles Land, which is farther south and relatively low, but it may be an outlying island of the Franz Josef group.⁸ There are, however, other problems of great interest in the north. The extent and bottom features of the Arctic basin are still little known, and only in a few places has the width of the remarkable continental shelf been defined. North of Alaska, the New Siberian Islands, and Spitsbergen, the edge has been charted and with less certainty north of Ellesmere Island and the Franz Josef group. In other parts it is still vague. When evidence is scanty it may seem rash to speculate on the origin of the Arctic Ocean, but there are many features about the Arctic basin which suggest that it is not comparable with the basins of the Atlantic and Pacific, and that it is possibly a relatively new feature of the earth's crust. On the other hand, the discovery in East Greenland of extensive series of Palaeozoic rocks seems to dispose of the idea of a former Arctic continent of great extent.

Another problem of importance and far-reaching influence is the mysterious fluctuation in the extent of Arctic sea-ice. The fluctuations appear to be cyclic rather than progressive, but so far defy satisfactory explanation. C. E. P. Brooks has recently pointed out the influence of the amount of ice in the Labrador and East Greenland currents on pressure distribution and consequent amount of precipitation in the British Isles.⁹ Here at least is one direct link between the Arctic and the most important factor in our climate. But until we know more about Arctic climatic conditions and the distribution of ice in the Arctic basin, we are not likely to find the cause of these fluctuations.

Facts so far available point to a rotary surface movement with overflows from an overcharged Arctic basin, by the Greenland Sea and other less important outlets. This movement may account for the tendency of ice-bound vessels in the Arctic basin to take a peripheral drift, as the *Fram*, *Jeannette*, *Karluk* and *Maud*. It may also explain the relatively smooth and unrafted ice reported from the vicinity of the Pole. Again, the heavy ice to the north of Greenland, which proved so baffling to the Nares expedition that it received the title of palaeocrystic ice, may be due simply to the heaping and rafting against the land of the pack that has been swept past the overflow of the East Greenland current. It cannot, however, be said that this circulation is proved. Far more observations are required.

Fluctuations in the amount of ice in the overflow currents may well be due to variations in the strength of these currents. These variations may be associated with departures from the normal in the amount of

⁸ Giles Land (also Gillies Land or Island), discovered in 1707, was re-discovered by J. Kjeldsen in 1876 and explored by A. G. Nathorst in 1898. It lies in about lat. 80° N., due east of Spitsbergen. This is where Giles himself placed it.

⁹ See the annual report on *The State of Ice in the Arctic Seas*, published by the Danish Meteorological Office from all available records. It is necessarily incomplete and leaves great areas untouched, especially the seas north of Asia and the Beaufort Sea where observations are most needed. C. E. P. Brooks, 'Pressure distribution associated with seasons in the British Isles,' *Quart. Jour. Roy. Meteorol. Soc.*, 52, 1926; W. Weise, 'Polareis und atmosphärische Schwankungen,' *Geogr. Ann.*, 6, p. 273, Stockholm, 1924.

water poured into the Arctic basin from the great Siberian and American rivers, which in its turn depends on causes far removed from Arctic regions. The complexity of the problem is almost baffling, but even before the chain of cause and effect is traced, useful work could be done in looking for correlations.

Methods of Exploration.

Every age has seen a change in the methods employed in polar exploration, and it may be of interest to review the resources of the explorer in the light of modern knowledge. In the early days of Arctic exploration, attempts concentrated on the hope of finding an open sea route to the north. Hence the lines of attack were by the two gulfs of warmth due to the northward flowing waters of the North Atlantic drift, Hudson Bay with Davis Strait and, particularly, the Greenland Sea. By the early part of the nineteenth century the hopelessness of advance by that means was realised, and not long after the prospect of an open-water route across polar regions in a lower latitude faded. Then came the period of probing the unknown north from a land base in a high latitude from which sledge journeys could take their start. Eventually the North Pole was achieved by this means long after Nansen, throwing aside all accepted canons of polar travel, had found a new and daring method. Instead of avoiding besetment he courted it: instead of battling with the floes he made use of their drift.

Meantime, the age of steel prompted a new method of attacking ice. The ice-breaker was tried away back in 1899, when the *Yermack* made an experimental voyage to the north-west of Spitsbergen. On more serious exploration the Russians used ice-breakers on the Arctic coast of Siberia in the years immediately before the Great War. But though an ice-breaker can deal with ice several feet in thickness, it cannot dispose of that ice; if the pack is close the ice-breaker will sooner or later become beset and helpless and at the mercy of pressure due to wind and current. Even a powerful ice-breaker could be crushed by such enormous pressure. Only a ship that rises is safe. For keeping harbours open and smashing new ice, the modern ice-breaker is valuable, but it has no place in serious polar exploration.

The polar pack-ice is still the most formidable obstacle that the explorer has to face. It may provide a laborious but uncertain road for sledging, but because of its drift before current and wind, it is always dangerous to vessels except those built on lines that defy crushing. Such a ship can drift in safety with the moving pack, but seldom can retain its freedom of action. Man to-day is little better able to penetrate heavy pack than he was three hundred years ago. The ice-infested seas are still barred to commerce and the only advance that has been made is in a knowledge of the position and drift of the ice, so that navigation of the edge of the pack is relatively safe.

And now another method of advance has been tried. The baffling pack-ice can be avoided by progress through the air. Air transit in the Arctic is not new; as long ago as 1897, S. Andrée made a hazardous and fatal attempt, but in those days the aeronaut could do no more than drift, and Andrée unfortunately drifted to destruction. In recent years the aero-

plane has appeared in the Arctic, and Amundsen and Nobile have used the airship. It was inevitable that aviation should be tried in high latitudes, if for no other reason than its spectacular daring, but so far its success has not been marked. That, however, does not necessarily imply that aviation is never to be a serious help in polar exploration. Amundsen's flight in the *Norge* gave a probable confirmation of what had already been deduced from indirect evidence. He found no land where none was expected. He saw nothing but ice-covered sea. Moreover, a rapid flight over snow-covered land, even if the eye could distinguish that surface from ice-covered sea, would tell little of importance. Byrd's flight to the Pole and back was of even less value to exploration, for on his track there was no possibility of land. The kind of exploration that is now required entails patient observation and accurate measurement. A quick-moving machine cannot help in this, and there is always the probability of mist to hamper the value and imperil the success of aviation in the polar summer. Amundsen himself admits that owing to 'a tremendous sea of fog, in some places of extraordinary density' in the Beaufort Sea, he may have passed over islands of low altitude without seeing them. So that on the only part of its course where land can possibly exist, the flight of the *Norge* has left us where we were, and the field is clear for the next explorer.

Even for reconnaissance the aeroplane has doubtful value. So much depends on ground organisation which never can be perfect in polar regions, and there is the even greater difficulty of satisfactory landing-places. On the long flight of the *Norge* from Spitsbergen to Alaska, not a single landing-place was seen, at least not one suitable to the eyes of those who had experience of polar ice. Pack-ice rarely offers the requisite surface, and certainly cannot be relied on to do so, while among drift-ice the necessary expanse of open water is seldom available for a hydroplane. The use of a lead may prove fatal by the ice closing in on the machine. In his first attempt on the North Pole in 1925, Amundsen very nearly lost his machines and the lives of his expedition by landing in a pool of water. As it was, he had to abandon one machine, and it was only by his skill and determination that he retrieved from disaster what was a complete fiasco so far as scientific exploration was concerned.

It should, however, be noted that G. H. Wilkins, from his flying experience north of Alaska, maintains that landing-places on pack-ice are numerous. He certainly made safe landings on two occasions without much difficulty.

For the transport of stores, equipment and collections, the aeroplane has little value because its use introduces an element of grave uncertainty into the work of the expedition. The explorer must be prepared for the journey on foot or by boat if his aeroplane fails him. He must carry the necessary equipment, or he is incurring a foolhardy risk. And in that case, why take the aeroplane at all?

In one respect, however, the aeroplane can be successfully used in polar water, that is in aerial survey of difficult country that lies within reach of a base accessible by sea transport and provided with a good landing-place. The value of aerial surveys has been proved in many parts of the world. The survey of the Irawadi delta in a few weeks instead of the

two or three years that ground work would have entailed, is a case in point. And J. M. Wordie has instanced the eastern edge of Greenland as a country where the aerial surveyor could rapidly make a map of the most rugged and untraversable country. The investigation of the movement of pack-ice in Hudson Strait, undertaken this year by the Canadian Government, is another instance of the value of the aeroplane in Arctic work.¹⁰

In the Antarctic, where I have pointed out the pioneer explorer still has ample scope, long-distance flights may be of some value. The ice-cap offers the prospect of better landing than the pack-ice. Yet in view of its great expanse there is even less chance of retreating on foot after a forced descent. The Argentine aviators, A. Pauly and Zanni, propose to fly across Antarctica from Graham Land on the Weddell Sea to Victoria Land or the Barrier edge on the Ross Sea next December. Their success depends largely on the efficiency of their machine. A forced landing will probably mean their total disappearance, but a successful flight will certainly give some broad results of value, although tantalisingly vague and inconclusive, as to the structure of Antarctica. An American flying expedition to the Ross Sea has also been announced.

Probably some reliable form of mechanical traction for sledges would be more serviceable than aviation in serious exploration. Dogs are useful for traction to men who are accustomed to manage them, but their area of action is limited by the amount of food that they require. Man-haulage gives longer range, but is terribly destructive of human energy. Machine-drawn sledges would require fuel, but the carriage of light fuel would not seriously impede their radius of use. The whole problem of mechanical transport really turns on its reliability. So far its use has been a failure. But we live in an age of rapidly increasing mechanical skill. Yet, is it ever safe to put absolute trust in a machine?

There must be risk in all exploration, but can one ever reduce the risk of the motor-sledge breaking down to reasonable limits? The wear and tear is tremendous, far greater than in a motor gliding smoothly through the air. On a short journey a breakdown would be merely a nuisance, on a long journey, far from the base, it might well be fatal. In short, while a man knows his own capacity he can never have an equal faith in the capacity of the machine. The use of motor-sledges is bound to come and they will be very useful, but undoubtedly they will introduce an element of uncertainty in the journey. They will increase the chance of success as well as the risk of failure.

Quite apart from means of transport, polar exploration has undergone changes in recent years. Equipment is better than it was of old, food is better preserved, more varied and more in accordance with human requirements. But the greatest change has come in the passing of the fear of the Arctic. Men who know the polar regions are no longer frightened of the cold and darkness and no longer shun the food resources of polar lands and seas. The terror that the Arctic inspired was a legacy of mediaeval superstition; the outcome, like all superstitions, of

¹⁰ Few men have flown in the Arctic. Some of the most valuable fruits of experience will be found in G. Binney's *With Seaplane and Sledge in the Arctic* (1925), and R. Amundsen's *My Polar Flight* (1925) and *The First Flight across the Polar Sea* (1927).

ignorance. Before Europeans had ever experienced a polar night, they thought that it must be fatal. The old whalers in Spitsbergen could conceive of no greater horror than to stay there during the winter. There is a tale that an attempt to found a winter settlement, to guard the whaling stores, failed because the settlers, who could be obtained only by releasing convicts, begged, on seeing Spitsbergen, to be allowed to return to gaol and even execution rather than stay and endure the unknown horrors of an Arctic night. The legacy of fear is still part of Europe's regard for polar regions, but the explorer has conquered it and he knows well that it requires no particular courage to face the polar climate. Fifty years ago expeditions dug themselves into winter quarters and stagnated half the year. Nares considered it cruelty to ask his men to sledge before April. But now winter is regarded by the explorer, as by the Eskimo, as a useful period for sledging. The snow and ice have better surfaces and the temperatures are not uncomfortably high.

Even more striking is the lightness of the modern explorer's equipment compared with the heavy load of old. In 'living off the land' and travelling lightly and quickly without supporting parties and depots of stores, John Rae set an example seventy years ago which was later followed by Nansen, Isachsen, Stefansson and others. On a purely meat diet man can maintain his health and vigour for weeks and months. If he can so break with his habits as to give up tea, coffee, sugar, bread and tobacco, his equipment in many of the more favoured parts of the Arctic can be reduced to personal clothing, sleeping-sack, rifle and ammunition. But the practice cannot everywhere be adopted. Even its most ardent advocate, Stefansson, had to abandon it at times and in certain gameless areas. The Arctic is not friendly everywhere: it can be very unfriendly, and it is rash to generalise from the most favoured regions.

The Antarctic may be termed invariably hostile except for its penguin rookeries tenanted for only a few weeks a year. Once the ship is left in the Antarctic, a provisioned base is absolutely essential. Journeys without stores would in all probability prove fatal. Antarctic travel must be mainly over the land-ice which is wholly devoid of any living thing. The sea-ice, in the lack of land-locked channels and basins, seldom affords a road for the traveller. Not only is it very rough, piled and rafted, but it drifts even in midwinter. Seals are seldom accessible to the Antarctic sledge traveller, for comparatively rarely can he descend from the ice cap to the sea-ice owing to the steep ice-cliffs.

Even in the Arctic it must be remembered that living off the land demands the sacrifice to hunting of much time that could be more profitably employed by a party of scientific men. While if hunters are specially attached to the expedition, in addition to the scientific staff, there is the liability, even certainty, of a large party exhausting the game in any one locality and requiring to move on in search of food. Such contingencies would be detrimental to the real aims of the expedition. Without neglecting the valuable resources of sea and land, it will seldom be wise for an exploring party to dispense wholly or even largely with transported stores, however great the temptation may be to lighten the load and thus widen the area of activity. In a forced march of retreat, however, ability to find food and confidence in its value are important.

A greater terror than the danger of lack of food in polar exploration used to be the prospect of scurvy. That has practically gone. Scurvy used to be considered inevitable sooner or later. No expedition entirely escaped it, and nearly all lost men and power of work through its ravages. Much of the bad reputation which the Arctic gained in the past must be attributed to scurvy. And its prevalence on the Franklin expedition—it was really attributable for its total loss—and on the Franklin search expeditions gave a grim aspect to polar travel which it has not yet lost in popular opinion. There is no excuse for the occurrence of scurvy on an Arctic expedition to-day, although there may still be risk of it on a journey over the Antarctic continent, but its total disappearance from the casualties the explorer has to face can be a matter now of only a few years. The advance of physiological science will no doubt result in scurvy being classed with the rare or extinct diseases.

Thus, as knowledge grows, the power of the explorer increases, and the old-time hardships that we read of seem curious fantasies or epics of heroic men battling blindly with ignorance.

When Europe came to realise that there were no commercial sea routes across the Arctic Ocean, a new motive, other than commercial gain, fortunately inspired polar endeavour or it might have ceased altogether. That aim was found largely in the attainment of the Pole. The actual attainment was of no scientific importance, but it was of value as an ultimate objective and the lure of the Pole led men onwards into the unknown, and thus it served science in its day.

Once the Poles were gained, that lure vanished. There is to-day as much need as there ever was for the penetration of the Antarctic continent along a score of meridians or of the passage towards the North Pole by more than one route across the Arctic Ocean. But the feat has been accomplished and so the aim no longer fires the popular imagination. It fails to serve as a bait to secure the necessary financial backing for a well-found polar expedition. It may be regrettable, but it is certainly true, at least in this country, that an expedition with purely scientific aims and no sensational journey or feat in its programme must appeal in vain for funds. These are seldom forthcoming for the advancement of pure knowledge. Scott and Shackleton fully realised this in putting their Antarctic plans before the public. Bruce, on the other hand, deploring the necessity, refused to accept it. And after all, high endeavour in the strenuous field of polar exploration has a value of its own, even if that value be not scientific. It is, however, unfortunate that in recent years more than one expedition has been successful in raising funds, and others have attempted to do so, for programmes that were little else than spectacular and bore the smallest prospect of useful work. This is to be deplored because it diverts funds from earnest work and sometimes even brings discredit on polar exploration. Every serious worker in polar research must regret the entry into the field, from time to time, of men who have few qualifications for the task and see in it merely an opening for spectacular notoriety, or a measure of financial gain by means of dramatic cinematograph films and newspaper articles.

I have tried to show that even if pioneer journeys have not ended, exploration is entering on a new phase, that of fixed stations of at least

a year's duration and preferably longer, where detailed researches in meteorology, biology, and other branches of science can be pursued. Many years ago Denmark led the way with such a station at Disko in Greenland. Norway has at least one permanent meteorological station in Spitsbergen, but the only permanent station in the Antarctic regions is the Argentine Observatory at the South Orkneys, founded in 1903 by W. S. Bruce, unless we look upon the temporary marine laboratory of the Falkland Islands Government at South Georgia as an Antarctic station. There is room for more, and it is to be hoped that some day there will be at least an oceanographical laboratory in that Arctic land, only a few days' sail from our shores, western Spitsbergen.

Meanwhile, we welcome the stimulus to real polar research afforded by the Polar Research Institute at Cambridge and the new interest in polar exploration evinced by the recent successful Cambridge expedition to East Greenland, and no less valuable Oxford expedition in North-East Land two years earlier. Such expeditions fill in details that were overlooked in the age of pioneer journeys when the scientific problems awaiting solution were not formulated. They can in one season accomplish as much as the older expeditions did in a year. We may look for useful work from the Cambridge expedition now engaged in the survey of the little-known Edge Island, Spitsbergen. Nor must we forget that for some years now the Royal Canadian Mounted Police in their patrols between their far-flung Arctic posts have been quietly conducting useful explorations. The excellent work of the Danes in Greenland should also be noted and especially the exhaustive work on the Eskimo which K. Rasmussen has extended westward to Bering Strait. Norway also is filling in the details omitted by earlier explorers in Spitsbergen and publishing a series of valuable monographs on that country.

Settlement of Polar Lands.

During recent years territorial claims have been made to all parts of Arctic regions that were not formerly subject to sovereignty, and even in the Antarctic great dependencies have appeared. This is an expression of the growing belief that polar regions are not merely desert wastes but have some economic resources of value to man.

Fur and oil first brought Arctic regions into the areas of commerce. The advance by sea, as with the explorer searching for a sea route to the East, was naturally by the two gulfs of warmth into Davis Strait and the Barents Sea. The most approachable Arctic lands were first exploited and first devastated by hunter and trapper. Thus Greenland and Spitsbergen have suffered first. The land approaches were naturally where continental land projects farthest north, Canada and Siberia. Those routes led to a later advance of the trapper, but to as ruthless an exploitation when once it began. Hunting cannot last: it is rapidly failing. Modern weapons are too effective, and already the Eskimo are suffering after a brief period of prosperity. But since the market for furs will continue and even grow, and since the best furs will always be Arctic winter skins, the demand must be met by breeding fur animals. Climate exercises a rigorous control on the commercial value of the

furs, a control from which there is no escape. Under wise game laws the Arctic lands and seas may produce a steady crop of furs, but the new form of exploitation will be rather an aspect of stock-raising than of hunting. Even the hunting of sea mammals will suffer eclipse as the civilisation of machines advances. The whaler has now deserted most Arctic seas, the sealers are fewer and the walrus hunter has nearly exterminated his prey. The addition of motor power to sloops has enabled the Arctic hunter to extend his area of operations by penetrating the pack farther than sail would admit. Arctic animal life has suffered as a result, as for instance the inroads on Spitsbergen reindeer in their relatively safe sanctuaries on the north and east.

Of all Arctic animals, at least of those that have a commercial value at present, the polar bear will endure longest, not because he is least desired, but because he is a sea mammal who lives in the inner fastnesses of the polar pack and can be hunted only on its fringes.

Exhaustion of game leads to a decrease in the number of hunters. So far as this decrease concerns temporary hunters from the south, it may lead to a slow revival in resources; but as regards the permanent inhabitants of Arctic America, the Eskimo, it has serious effects. Their standard of living is reduced, want appears, and their culture and their race languish. A century ago the Eskimo had struck a balance between numbers and resources. They were perfectly attuned to their environment even if their area of settlement oscillated a little on the confines where game was liable to fail as numbers increased. Then the introduction by Europeans of more effective weapons upset the balance. So nicely adjusted was their equilibrium that the looting of iron from McClure's abandoned ship, *Investigator*, was probably the cause of the virtual extermination of musk-ox on Banks Island and its consequent abandonment by the Eskimo. The exhaustion of game brought the Alaskan Eskimo to the verge of starvation a few years ago, and if the United States Government had not intervened, might have wiped out that branch of the race.

The resources of the Arctic are not, however, limited to hunting, even if we include with hunting the breeding of fur-bearing animals. Outside Greenland, with its ice-sheet covering 94 per cent. of the island, a comparatively small area of Arctic lands at present bears permanent ice. The Canadian Arctic islands are free except small ice-sheets in the east, in parts of Ellesmere and Baffin Islands; the Eurasian Islands have more, though there are large free areas in Spitsbergen and the south island of Novaya Zemlya, while the whole of the mainland areas of Siberia, Alaska, and Canada, which can by any stretch of meaning be called Arctic, are free from permanent ice. Beyond the northern limit of trees there may be said, at a rough estimate, to be about 5,000,000 square miles of ice-free land, or considerably more than the total area of the United States. Most of this is covered with some kind of tundra. The mainland and some of the island areas have a close covering which in favoured places may attain a luxuriance and vigour of growth which has little relation to latitude and contradicts all preconceived notions of Arctic productivity. Thus western Ellesmere Island and north-western Greenland are noted for their vegetation. In other places the plant covering is open, and on

some of the islands there are areas which are practically desert and bear only a few mosses, lichens, and scattered plants.

These tundras are the natural grazing grounds of caribou, reindeer, and musk-ox. The musk-ox go farthest north, being found even in Ellesmere Island and northern and eastern Greenland, and they are confined to the American Arctic. Neither animal—for of the three caribou and reindeer are essentially the same—leaves the Arctic in winter. They are natives of the north and do not suffer from the winter cold and light snow. Their only enemy besides man is the Arctic wolf. It preys successfully on the reindeer and is less likely to attack the musk-ox, which not only can fight the wolf with its sharp horns but finds safety in numbers. The wolf seldom cares to attack a herd.¹¹

Musk-ox and reindeer are complementary to one another in their food requirements. The reindeer prefers grass and willow shoots in summer and the lichens known as reindeer and Iceland moss in winter, while the musk-ox eats grass and shoots at all seasons. Now grass and shoots are more abundant than lichens on the Arctic tundras, so that the number of reindeer are limited by the winter feed, while much grass remains surplus and could be utilised by musk-ox. The relatively restricted area of the musk-ox to-day in Arctic Canada is solely due to the ease with which it is hunted. Now that it is protected by law, there is no reason why its range should not increase considerably.

The reindeer has been domesticated from early times in the Old World, even if we cannot be sure that the reindeer of Stone Age man in Europe were tamed and not merely wild flocks. The prosperity and very existence of most peoples of the Old World tundras from Lapland to Bering Strait to-day depend on the reindeer. Lapp, Zirian, Samoyede, Ostyak, Tungus, Chukchee, and Koryak are all reindeer breeders to a greater or less degree, and the reindeer provides them with meat, milk, clothing, and leather. They alone are the prosperous tribes, and their prosperity, as is the way of prosperity, causes them to look down on the hunting and fishing tribes such as the Yuchagir, Kamchadals, and some Samoyedes, who have a hard struggle to survive. Yet it should be noted that even among the Chukchee, who are the most successful reindeer breeders in Siberia, the reindeer is only partially domesticated, and the herds often run wild owing to the interbreeding with wild deer. The herds of the Koryaks also frequently revert to the wild state.

In the New World, including Greenland, the caribou has never been domesticated. The Eskimo are chiefly dependent on sea mammals and fish. Sea mammals yield a greater supply of oil, their only source of fuel and light, than caribou and musk-ox. To the Eskimo, land animals are a secondary consideration, valuable in the summer nomadism as offering a change of food and variety of occupation, but rarely now the staple of their existence. Even the Caribou Eskimo, inland dwellers to the west of Hudson Bay, have never tamed the reindeer, but exist by hunting the wild herds.

In his well-known efforts to dispel the prevalent misconception about

¹¹ The Canadian Government now offer £6 per pelt for wolves destroyed in the North-West Territories. The skins find a ready market. In 1926 about a thousand wolves were thus accounted for.

the Arctic, V. Stefansson has drawn a glowing picture of the future of the Arctic prairies.¹² His statements have met with some criticism, not invariably by men who know the Arctic. It may be well to examine his arguments in some detail, since this matter touches the future of the Arctic and its possible contribution to the material welfare of man.

Experiments in reindeer breeding in Alaska were begun in 1891 with the introduction of a small herd of sixteen deer from Siberia. Next year 167 more were introduced. This was an attempt by the United States Government to give a new means of livelihood to the Alaskan Eskimo, who were in dire straits because game was exhausted. The experiment was entirely successful. The herds have been doubling themselves every three years, and the 1,280 deer introduced before 1902 have now increased to about 500,000. The United States Department of Agriculture calculate that the grazing grounds of Alaska can support over three million reindeer at a low estimate. At present the deer are a small variety, but it is hoped to increase their size by interbreeding with wild caribou. This, however, must be done carefully lest the herds become unmanageable.

There can be no doubt of the success of the experiment in Alaska, and the forecast of an Alaskan production for the market, in less than twenty years, of over a million carcasses of reindeer a year is probably no exaggeration. This is the equivalent of nearly three million sheep, and so would be no small accession to the meat resources of the United States.

It has been suggested that the Alaskan success shows what can be done in Arctic Canada, the Barren Lands and islands, and possibly also in parts of Greenland. Undoubtedly there are wide grazing grounds that are now practically unoccupied, but it is easy to exaggerate their potentiality. Estimates of productivity based on the number of species of plants here and there or per square yard have little value. Many of the plants are of no use to grazing animals and others are rare. It must never be forgotten that most Arctic plants grow slowly and have poor means of reproduction, so that Arctic prairies can easily suffer from over-grazing. One reason for the wandering of the caribou and musk-ox is their liability to exhaust any but the richest grazing grounds to such an extent that a year or two, or even more, are required for their recovery.

Siberian reindeer in a wild state commonly migrate southward to the forest edge in winter and even on the rich pastures of Lapland nomadism is essential. The Lapps know well that the sites of the winter villages must be frequently changed in order to ensure enough lichen for the herds. Intensive pasturage on confined areas is impossible.

Six years ago the Hudson's Bay Company acquired from the Canadian Government a lease of 100,000 square miles of tundra in southern Baffin Island and imported five hundred reindeer from Norway to Amadjuak on Hudson Strait. All the deer perished. Yet the failure of the experiment must not be used as an argument against the possibility of reindeer breeding in Arctic Canada. Siberian reindeer, for there are many varieties of the reindeer, would probably have suited the conditions better than the tamer and richer-feeding Norwegian variety. And furthermore Baffin Island, as its small ice-fields bear witness, has a greater precipitation than

¹² V. Stefansson, *The Northward Course of Empire* (1922); *The Friendly Arctic* (1921); 'Polar Pastures,' *The Forum*, Jan. 1926, and other articles.

most reindeer lands and a humid climate seldom suits reindeer. The failure to acclimatise reindeer in the Orkneys and the Scottish highlands, many years ago, was attributed, no doubt rightly, to the dampness of the climate, for the food supply was entirely adequate. Lastly, the wolves of Baffin Island made serious inroads on the new flocks quite unprepared to defend themselves from this unknown enemy. The wolf is a far more serious enemy than man to the reindeer and more effective in reducing numbers.

There is no reason to suppose that the domestication of reindeer, starting with Siberian stock and gradually introducing the American caribou, will be anything but successful in most parts of the Canadian tundra, in the rich pasture lands of western Greenland, and the more restricted areas of Spitsbergen. All these regions have supported vast numbers of reindeer in the past, and should do so again if excessive hunting is curbed, wise game laws instituted, and the wolf exterminated, as Canada is endeavouring to do. Already the killing of reindeer in Spitsbergen is totally prohibited until 1934, the first enactment of Norway's rule in her Arctic possession.¹³

Alaska is said to have pasturage for 4,000,000 reindeer. Basing his estimate on this figure, Stefansson calculates that the Arctic tundras as a whole are capable of supporting about 100,000,000 reindeer and perhaps five times as many musk-ox. This is probably an over-sanguine estimate, for it must be remembered that the Alaskan herds are mainly in the more fertile valleys of the south and south-west, which have few, if any, equals in fertility in the tundras farther north; but even if we reduce the numbers considerably, say by as much as 50 per cent., there remains a possible food production from the waste Arctic lands equivalent to some 1,000,000,000 sheep, or more than ten times the total number of sheep that Australia now supports.

This would, of course, take many years to accomplish, and naturally will not occur until the temperate lands of the world are more fully occupied than at present. But gradually as world population multiplies and food production has to be increased, the lands that are not fit for cereal growth will command attention by their possibilities for pasturage. It is a geographical axiom that the herder must always give way to the tiller of the soil with his more intensive occupation. With the extension of dry farming, there seems little likelihood of any considerable areas of temperate lands in the long run being left to pastoral pursuits. But the Arctic tundras are entirely unsuited for agriculture by unfitness of soil and shortness of summer for ripening the grain. Their advantage as pasture land is that the farmer can never displace the herdsman. As the world's supply of beef decreases, the supply of venison and musk-ox flesh will come more into demand.

A further important aspect of Arctic pasturage has been suggested in the supply of leather and wool. The musk-ox wool has been shown to have the qualities of merino and to be softer than cashmere, but it is unlikely that it will be possible to shear flocks that have to resist the rigours of a

¹³ Norwegian proposals for game laws are published in *Naturfredning i Norge, Årsberetning*, 1926 (Oslo, 1926). See also *Scottish Geog. Mag.*, May 1926.

long Arctic winter or the pestilential irritation of the mosquito in summer.

The reindeer industry in Alaska is largely in the hands of Eskimo. It was started to maintain them and 70 per cent. of the flocks now belong to Eskimo. In Siberia, where the reindeer are for native use only, there being no export of meat as from Alaska, all the herds are owned and managed by natives. In Arctic Canada, when the industry grows, no doubt Eskimo and Indians will be largely employed to tend the flocks, but the slaughter of the beasts, the preparation of the meat and its export, as well as the transport arrangements, will no doubt be in the hands of Americans, Canadians, and Europeans. Eskimo and white will meet even more than they do to-day.

The experience of the past, in every quarter of the globe, of the fate of hunting peoples in contact with more highly organised races gives room for legitimate doubt as to the ultimate survival, still less the increase, of the different peoples of the tundra. The clash of widely divergent cultures, to say nothing of the introduction of new diseases, almost invariably has meant the extinction of the more primitive people.

The same will probably occur in the Arctic. The latest reports from the North-West Territories of Canada do not hold out much hope for Eskimo survival. The Eskimo are depending more and more on the police and trading post for supplies and help. Only the remoter tribes seem to preserve their strength and independence. The Hudson's Bay Company and the Canadian Government, through the Mounted Police, are doing all they can for the Eskimo in sheltering him from the evil effects of civilisation. Yet the fact is admitted by the police themselves that the sturdiest and most attractive Eskimo are those who are not in contact with outposts of the white man's civilisation.¹⁴

Siberian natives in their greater isolation will no doubt last longer, but they also show signs of failing.

Up to the present the tide of human migration has flowed and ebbed on Arctic shores and has been mainly a seasonal movement, marked even in the permanent residents by a great degree of nomadism. But eventually the tide of white settlement will definitely set northward, even to the Arctic seas, and in its flood destroy the present inhabitants.

It is no more presumptuous to forecast a scattered population of reindeer and musk-ox farmers in the 'barren lands' of Arctic Canada, the tundras of Siberia, and even in Greenland and Spitsbergen too, a hundred years hence than it was a hundred years ago to suggest sheep farmers in the plains of Australia or wheat fields in the Peace Valley of Canada. Every land beyond the frontiers of settlement has been a 'never-never land' to unadventurous and unimaginative folk living in sheltered homes. But in most cases the prediction has been falsified.

Prejudice and antipathy, which loom so strong at present, can be ignored: when the Arctic calls for population and offers inducement in the form of material gain, all difficulties of that kind will vanish, just as the old-time horror of the tropics disappeared as knowledge grew and prospects of gain loomed through the heat. The only question that

¹⁴ See Report of the Royal Canadian Mounted Police, 1926, and K. Rasmussen, *Across Arctic America* (1927).

remains unanswered is the adaptability of peoples of European descent to life in the Arctic climate. At present there is little evidence on which to base satisfactory conclusions, for nearly all migration in historic times has been either within the temperate zone or from temperate to tropical. There are few instances of migrations from temperate to polar or even from warmer to cooler climates.

The problem is one of considerable importance in the future of human settlement for two reasons. First, because there is no real evidence that the white races are suited for the tropics; that is to say, for permanent racial transference as apart from visits. All the evidence that is conclusive points the other way and suggests that only by a slow process of natural selection can the white races ever find a sure footing in the tropics. Long before that is achieved, the coloured races will have effectively occupied the warm lands.¹⁵ This means that the white races must turn, as in effect they have been turning for several centuries, polewards in their search for new homes. Secondly, the possibility of polar settlements affects, as I have tried to show, the future food production of vast areas which at present enter little into the economic life of the crowded populations of food-importing communities.

There are plenty of isolated cases to illustrate the healthiness of polar climates and how a man can thrive in the Arctic for a year or several years. But it is unsafe to found faith in polar colonisation on such cases. First, they are almost entirely cases of men, and secondly, of men in the prime of youth and of strong physique and mentality at the outset. Witness the trappers of the Hudson's Bay Company, the fur traders of Siberia, or the adventurers in the Klondyke and Yukon goldfields. It has even been argued that because a negro accompanied Peary to the Pole there is no reason why peoples of the tropics should not colonise the Arctic!

Successful colonisation entails not merely the maintenance of health and vigour during a shorter or longer stay in the new environment. It demands that race transference can take place and that the transferred population can thrive with undiminished fertility from generation to generation without the infusion of new blood from the mother country. From this point of view the health and energy of women and children is the important consideration.

The Danes in Greenland are the nearest modern approach to this state of affairs, but though the Danish families thrive during their stay in the North they do not regard Greenland as a permanent home: they are exiles counting the years until they can return to Denmark. At certain of the large mining camps in Spitsbergen there are Norwegian families of several years' uninterrupted residence with bright, healthy children born and reared in the Far North.

There are, unfortunately, no data bearing on climatic energy in polar regions such as E. Huntington has collected for the United States and some

¹⁵ From this statement it does not of course follow that all regions within the tropics are necessarily uncolonisable by whites, since altitude may in certain places compensate for the ill effects of a tropical climate. Nor does it follow that a few exceptional families may not now and then persist in the tropics for a generation or two, though such instances generally involve the introduction of fresh blood.

other countries. But if his conclusions are true, that a low mean daily temperature is more conducive to high mental energy than a high or even moderate one, then we can be sure that the Arctic colonists will not at least suffer intellectual degeneration. On the other hand, those of us who have experienced the extraordinary physical energy which is one of the joys of life in polar climates must be a little sceptical of Huntington's further conclusion that a mean daily temperature of about 64° is the optimum for physical activity. That figure would appear to be too high, but of course it represents a value that is extraordinarily difficult to measure.

The only example of real Arctic colonisation that exists is that of the old Norse colonies in south-western Greenland founded in the tenth century. At their height the two colonies must have contained between 2000 and 3000 people, men, women, and children, scattered in about 280 farms, where they kept cattle, goats, sheep, and horses, perhaps raised a few poor crops of little account, and hunted bears, reindeer, and seals. There is no need to recall the history of these settlements, how trade with Europe gradually ceased and how the Norsemen had entirely disappeared when late in the sixteenth century communications with Greenland were reopened.

Recent Danish researches at Herjolfsnes, near Cape Farewell, have discredited the old belief that the colonies disappeared either by Eskimo extermination or by fusion with the Eskimo races.¹⁶ It now seems clear, at least as regards Oesterbygd, that the Norse race maintained its racial purity and did not 'go native.' The general reluctance of the Nordic races to mix with widely divergent stock was as noticeable then as it has been in later centuries. Examination of skeletons in the churchyard of Herjolfsnes reveals the interesting facts that while clothes and ornaments, in graves of the fifteenth century, show little trace of Eskimo influence, the skeletons all show signs of rickets or other malformations and stunted growth, but no sign of racial mixture with the Eskimo. There is also a very high proportion of remains of infants and young people. Evidently, therefore, the Norse colonies, at least Oesterbygd, perished by exhaustion. Even if the climate were changing for the worst during the existence of these colonies—and such a change is by no means proved—there is no reason to suppose that the habitual meat diet failed. The cessation of communications with Europe cannot have affected the diet of the colonists to any great extent. The *King's Mirror*, describing conditions when the colonies were prosperous, notes that most of the settlers did not know what bread was. And what else could they get from Europe to vary their meat diet?

The conclusion is, therefore, that the Norse colonists in Greenland died out for want of new blood, or, in other words, that they were not acclimatised to their Arctic home. From this it might be argued that even the Nordics can never colonise the Arctic. Certainly no other race from temperate climates is likely to try, since the Nordics alone show that distaste for gregariousness and that capacity for enduring solitude which

¹⁶ See papers by P. Nörlund, F. C. C. Hansen, and F. Jónsson in *Meddelelser om Grönland*, LXVII (1924), and by D. Brunn, *ditto*, LVII (1918).

are essential qualities for the task. We may even grant them a greater measure of physical enterprise and love of wandering than other people.

The Greenland experiment is not, however, a sure criterion of Nordic unsuitability for the Arctic. The pastoral settlement, which is suggested, will be a slow colonisation, in which natural selection will have some say. Those suited will remain, others will move away or perish. But the colonists will not be cut off from the world: they will be in close touch with it. New blood will continually flow in their veins, so that the unchecked course of natural selection which operated in the old isolated Norse colonies and killed out the more nervous and imaginative type, a type that is least adapted to the Arctic, will not have free play. There is no reason why the race should become impoverished by the elimination of its most progressive element. Even though a diet solely of meat has proved wholesome enough in the case of Eskimo and some explorers, it will not be necessary for the Arctic colonists to subsist on it entirely: transport facilities will bring every variety of food to their doors. If the Norsemen suffered from insufficiency of certain ingredients in their diet, a similar fate will not be the lot of the colonists of the future. If they died out by lack of new blood and continual inbreeding, the Arctic settlers of the future will be able to avoid that disaster.

Such is the legitimate forecast, as I see it, of the *outer* rim of the Arctic of the future with its prosperous, though scattered, colonists of pastoral interests, and its fur farms here and there supplying high-priced Arctic furs in limited numbers. But the settlement must wait until the pressure of population or the world's resources is even greater than it is to-day. The remoter parts, those without rich tundra and the ice-covered seas and lands must remain deserts, visited only by roving hunters and occasional explorers. In short, I see a shrinking of the Arctic wildernesses, but never their disappearance. I cannot take as glowing a view of Arctic settlement as Stefansson can, or visualise the same attraction to population which he forecasts, and I am sceptical of the value of Arctic lands as stations on the air routes of the future. But even if he has overstated his case, his long-sighted views have done something to dispel current misconceptions and reduce the area of polar wastes.

Of the possibilities of Arctic mining, little need be said. The subject is not purely a geographical one. Where minerals of value occur they will sooner or later be mined, like the cryolite of Greenland, the copper of Arctic Canada, and the coal and gypsum of Spitsbergen. Geographical considerations undoubtedly affect the issue, but in the main it is an economic problem. Difficulties of climate can nearly always be overcome, and transport can generally be arranged if the mineral will pay the cost. As coal increases in price, as it promises to do, the Spitsbergen coal mines will pay well, and if gypsum finds new uses and higher values, the vast deposits of Spitsbergen will be mined on a great scale. Similar considerations apply to Arctic copper. But the Arctic lands as a whole, so far as we know, are not rich in mineral wealth. The only one that will eventually have a large mining population is Spitsbergen, and there manufactures may develop in relation to the gypsum and metallic ores.

The Antarctic has no human problems comparable with those of the Arctic. It is true that whaling has recently invaded the Antarctic, with

the vessels in the Ross Sea, not to mention the sub-Antarctic whaling in South Georgian and Falkland waters. But this can be little more than a passing phase. Already some species of whales show signs of depletion of numbers, and unless whaling is so rigorously shackled by regulations as to make it of little profit compared with risk it entails, the industry must kill itself in a few years' time. For the rest there is nothing of value in commerce in the Antarctic: certainly nothing that it can possibly pay to exploit. The stories of future Antarctic coal mines can be dismissed as a dream without any solid foundation. It is fortunate. And those of us who care for the wild waste spaces of the world are glad to think of the Antarctic as free from invasion by our modern civilisation with its insistence on hurry and noise. We are glad to remember the lonely places of the world and their matchless beauty, content to know that to others they will bring the same fascination they did to us in years gone by.

RATIONALISATION OF INDUSTRY.

ADDRESS BY

PROF. D. H. MACGREGOR,

PRESIDENT OF THE SECTION.

I.

A VERY remarkable change took place after the war in the expression of both public and economic opinion in respect of what may generally be described as the problem of industrial leadership. In the former period the growth of great concentration of control over production was regarded with distrust, and as a thing which had to be carefully watched in the interests of the community. While it was admitted that the old theory of competition was not working without disadvantages, it was believed that all over, these were less than the disadvantages which might result from anything monopolistic. It was considered that the anti-Trust legislation of the United States and other countries was a serious and wise attempt to deal with a public danger. The theory of business profit was connected with the fact that risk was paid for, and had therefore to be taken; that enterprise essentially involved this risk-taking function of the producer; that the best risk-takers would win in the competitive struggle, and that it was in the general interest that the worst should be eliminated. Because of Joint Stock, the units of enterprise became larger and more powerful, and this by itself tended to make competition more intense; so much so that it became usual to apply military terms to the relations of producers, to speak of 'the war of competition' that was fought between the 'captains of industry.' But there was no settled opinion that, alongside of the growth of Joint Stock, there had not grown up conditions which qualified the risks of competition; transport widened the market, there was a great organisation of market intelligence, big concerns knew more about each other, and in many ways they co-operated more fully than would have been possible if they had remained more numerous and less powerful. There was a recurrence before public Commissions and inquiries of all sorts, of the producers' view that competition had become anarchic, chaotic, excessive, unregulated, or destructive. But this kind of complaint did not translate itself in all countries into the obvious methods of remedy by combination. It was always said that British producers remained comparatively individualistic in their attitude, meaning that they were unconvinced by the arguments used elsewhere. The American combination movement was often explained by the special effect which her high tariffs had in over-capitalising protected industries, and causing on that ground an excessive competition that need not have happened. Again, it could not be said that, given

private enterprise and the risks it implied, there was such a tendency to bankruptcy as to show an irrational position. Over the period 1903 to 1912, for instance, the statistics of liquidations of Joint Stock Companies in England were on the average as follows :—

Companies on the Register.	Paid-up Capital (1000's).	New Companies.	Liquidations.	Capital involved in liquidations (1000's).
40,101	1,862,107	5,028	1,860	54,531

This was an average rate of liquidation of 4 per cent. of companies, involving 3 per cent. of the capital. It is not an unqualified record of competitive results, because no country was without some extent of combination. But it is the record of prevalently competitive conditions, including those which obtained under partial forms of combination.

Public and economic opinion had come by stages to tolerate, approve, and recommend labour combination. But the conditions are different, because an individual workman is not related to others, as one business concern is to its competitors. Labour is necessarily employed in groups. In any case, Trade Unions applied to only one factor of production, but combination of businesses applied to the whole product as it came on the market.

Thus, on the whole, the combination movement was a 'problem.' Books were written under such titles as 'The Trust Problem,' 'Wealth against Commonwealth,' 'Frenzied Finance,' 'Trusts and the State,' 'The New Feudalism,' and so forth. To call a certain result a 'problem' does not mean that it must be stopped, but it implies doubt, refusing to certify the results as rational and inevitable. The United States in particular legislated to break up combines of a certain degree, and to impede their methods of working.

II.

The post-war tendency is to change this attitude. The alteration in point of view is very remarkable. Anyone can see this who reads the documents submitted on the subject to the World Economic Conference. One writer confidently states that the right thing to do now is 'to form as many international agreements of producers as possible.' But these international agreements presuppose national combines which are parties to them; and if world economy requires the combine formed by agreement (the Cartel), then *a fortiori* of the national economy.

This change of attitude has been urged both on public opinion and on producers under very high auspices. The Reports of the Reconstruction Committees on *British Industries after the War* are unanimous in asking for a change of the public attitude toward producers' combinations. The Report of the Balfour Committee on Efficiency puts questions of combination in the forefront. It is not easy to appreciate this without considering the future to which such an impulse may lead, in respect of our attitude toward organisation. There are three large conceptions that are related to each other—competition, combination, and public administration. A change equal to that which has taken place in reference to the first two of these would carry us far from the second toward the third. Public industrial administration, in its broad features,

is as much distrusted now by prevalent opinion as the Trust Movement used to be, but no more. It is well to keep this in mind in dealing with the recent evolution of opinion.

The change is due to a few separate causes. The war enforced a good deal of co-operation, since the Government had to deal with producers as a group in their industries. In some industries it led to constructions which the market could not afterwards carry at their capacity, and combination is a method of regulating excess of capacity. In some cases Governments have, because of special national interests, been a party to the formation of large combines. All this influences opinion. But most important of all, as the Geneva documents show, has been the reaction upon national ideas of the international industrial proposals. The formation of the International Steel Agreement was a powerful influence in this direction. There were two special reasons for this—its semi-official support by the political governments involved, and, above all, the fact that it could be presented as a form of pacification between Germany and some of her former enemies, especially France. If this could be done once, it could be done again. There had formerly been international agreements, it is true, but they were not so sure of their welcome as they might be after all that was written of the Steel Cartel. Their claims became more confident, and this meant that combines within each country were also placed in a more favourable position than before.

The leadership came from Germany, and for that reason we have now the ponderous name of 'rationalisation' to describe *methods* which depend upon this *policy*. This word may be used of such results of large-scale production as standardisation, and it is also used of the more broadly applied system of scientific management. This paper is not concerned with these aspects of the idea. It is obvious that internal business administration should be scientific, and it is entirely for the heads of businesses to discover the right technical methods; the 'planning' of work seems to an outsider to be something which ought always to happen, and it is remarkable that this *general* conception should still be taken as noteworthy. Standardisation of final products seems, from the public point of view, less completely rational than simplification of processes. But, from such bases, 'rationalisation' has been built up so as to imply the right organisation of an industry considered as a type of government, the producers being so related as to enable such policies to be applied as works specialisation, non-destructive elimination of the weak, and the control over the entrance of new establishments. Now this in turn implies some degree of monopolistic control. And it appears to be historically the case that, when the leaders of German industry found themselves after the war and the Treaty of Versailles in conditions confused by inflation and the loss of the sources of supply in the Rhine Provinces, they sought to justify the great combines which were formed by a title which would give them the strongest commendation. Pre-war Germany did not like Trusts or Concerns. For a time at least, strong personal leadership seemed necessary after the war. And the conception of 'rationalisation' which was adopted and urged, as the highest form of what was scientific in business management, had a successful flotation, and has crept into the terminology of organisation of industries.

The World Economic Conference did not give to these claims the endorsement which they hoped to obtain. We get only the conclusion that combines may be good or bad according to the motives and outlook of those who direct them. This means that, as economists, we have to return, without any prejudice from names and titles, to the study of a stage of evolution, taken as actual. The change in public opinion must no doubt also be taken as a fact. But this is a thing which may at one time swing toward the producer, at another toward the consumer, according to the conditions of the economic conjuncture. At present the difficulties of the producer are more prominent than usual. On the other hand, in the immediate post-war boom, we had the Committee on Trusts, the Profiteering Act and its Committees, and a different attitude toward what had not yet come to be called rationalisation. From any long point of view, a perplexing problem is offered, because if on one hand it is held that industrial joint stock competition is becoming irrational in intensity, and will be destructive of itself as one industry after another reaches an advanced stage of capitalist organisation—on the other hand, monopolist tendency is also unstable in face of public criticism. Hence some dread, and others hope for, more attention to the third method, that of public control, applied at any rate in some large instances.

III.

But it is still possible that, besides the insecurities and instabilities of competition, and the dangers of monopolist influence, there may be another idea according to which private enterprise may work out its future. This is the idea of leadership. It was the view of the Balfour Committee that, if industry was to be adequately responsive to changing conditions, and was to develop co-operation amid competition, it would specially need 'the exercise of the highest qualities of imaginative leadership.' If we compare industry with the other great systems of administration—political, military, and ecclesiastical—it is evident that the latter exist as systems because leadership has a definite place within them. They are organised under this form. In industry the fact is tending to obtain more consideration, but the question is of its formal recognition and status. Policy means leadership, and leadership means control; to control anything well, it is necessary to control a large part of it; and industry is so far from being, as regards conceptions of organisation, *in pari materia* with other organised forms of activity, that definite leadership has to overcome objections of a quite unique kind. This is because of a fundamental difference between industry and the public services, in respect of their immediate aims, and of their relation to the idea of responsibility. It will later be seen how this affects arguments relating to industrial control, and to the creation within industry of any sort of employees' franchise—an idea brought over from politics, on the implied assumption that politics is the type of democratic and responsible control. Meanwhile it is necessary to show how evolution has created the leadership in industry which seeks to confirm its position by combination, but whose 'sanctions' create the industrial problem referred to above.

An analysis was made of the data furnished to the manufacturing Census of the United States in 1919, which showed that, even in that country of large enterprises, the home of the Trusts, most businesses still operate single establishments. Grouping of establishments under one control, extending from groups of two to groups of over a hundred establishments, accounted for only about $7\frac{1}{2}$ per cent. of all the establishments operating. The large groups which make possible a strong personal leadership in industry must therefore account for a very small percentage of all the producers. The persistence of the producer of small or moderate size is still a marked feature of modern industrial organisation. The following analysis of the facts may be taken as a basis of the present position. It refers to manufacturing industry, exclusive of what are called 'hand and neighbourhood (or local)' industries, such as the village blacksmith. No establishment is included which did not have a product worth 5000 dollars in a year. The basis of this comparison from 1909 to 1923 is the number of persons employed per establishment.

Wage-earners per Establishment.	Establishments per cent.			Wage-earners per cent.			Establish- ments (1000's).	
	1923	1914	1909	1923	1914	1909	1923	1909
0—5	44.6	42.7	39.8	2.5	2.7	4.7	87.5	68.9
6—20	27.8	30.5	32.9	6.9	8.7	9.7	54.6	56.9
21—100	19.1	19.1	19.9	19.3	22.2	23.4	37.6	34.5
101—500	7.1	6.6	6.4	33.0	34.7	34.2	13.9	11.0
501—1000	.9	.73	.69	14.1	13.5	12.7	1.8	1.2
1000 and over	.5	.34	.29	24.2	18.2	15.3	1.0	.5
							196.3	173.0

In this distribution the number of the smallest establishments in 1923 is inflated by the change in prices, which would bring within the range of the Census a large number which would otherwise have been below the 5000-dollar limit. Allowing for this, the persistence of establishments of moderate size is notable.

The average size of establishment in that country, when allowance is made for changes in classification, has increased since 1899 as follows:—

Establishments.	Wage-earners per Est.		
	1899.	1914.	1923.
All	22.7	25.5	—
Over 5000-dollar product	—	38.6	44.7
Index	100	112.3	130.3

the figure for 1923 being, in view of the classification and of prices, too small.

When account is taken of contribution to the national product, the data for 1923 show the following result (subject to gross product being a comparative index of net product) :—

Value of Product (1000 dollars).	Establish- ments per cent.	Wage- earners per cent.	Product per cent.
5—20	31·6	2·2	1·1
21—100	36·9	8·2	5·7
101—500	21·4	19·6	15·7
501—1000	4·9	12·9	11·1
over 1000	5·2	57·1	66·4

This last table shows in the most striking way the degree of leadership which has been obtained by the small number of large establishments. And so far as it is large establishments which enter into combinations, their influence over policy and prices is increased.

More detailed examination of particular industries shows that it is not only in the great industries that this result holds good. No relation exists between size of industry, expressed in persons employed, and scale of production, or concentration of power. Some quite small industries stand high on the list by both these tests.

Germany is more typical of older countries where family businesses have played a larger part than in America. In Germany also, the Cartel system was, until the war, the usual way of obtaining control, and it tended, as compared with the Trusts, to maintain the smaller establishments. The following gives a pre-war comparison, from which the very small establishments are eliminated :—

Establishments employing	Per cent. of Establishments.		Per cent. of Employees.	
	U.S.A. 1914.	Germany. 1907.	U.S.A. 1914.	Germany. 1907.
6—50	75·5	87·1	20·0	35·2
51—100	10·8	6·7	11·8	15·4
101—500	11·4	5·6	35·7	32·8
500+	2·0	·6	32·5	16·6

For France, the general form of the table at the Census of 1921 is similar. As regards this country, the only data available are those of the capitalisation of Joint Stock Companies. Over the period 1919 to 1925, of all companies registered, only 2·6 per cent. had a capitalisation of over £200,000, while over 67 per cent. were capitalised below £10,000.

In the conditions which these results show, the largest producers inevitably feel themselves drawn together in order to create an administration for their industry. Evolution has given them a possible leadership which they desire to confirm. The large fringe of smaller producers is felt to be an obstacle to this purpose. The position of the large producers gives them an oversight over the market the confirmation of which means the organisation of the industry against inroads and uncertainties, overlap

and weak selling, and it is this further organisation which is presented as industrial rationalisation. Hence the terminology which is applied to the excesses, or destructiveness, or anarchy, of modern industrial competition. As a matter of industrial psychology, the desire to be at the head of wide-reaching organisations may have just the same motives as the desire for control in other spheres. It comes up against the same problem of exceptions which political, military, or ecclesiastical organisation wishes to incorporate in a system. It may indeed be said that, upon the possibility of creating in industry, and reconciling with public opinion, spheres of influence which will make industrial leadership as attractive as political or any other form of leadership, depends the supply to industry of the highest organising ability. There are recent cases in which, when such a sphere in industry was open, it has been preferred to political office. As compared with the services just mentioned, industry had, however, to evolve into a condition of large and influential units of enterprise, in order that any further step might appear possible. The data quoted above show how this position has been reached.

IV.

In the problem of industrial organisation there is involved an element which does not belong to the other great types of organisation. In the latter, the desire for efficient unity of control, strengthened by personal aspirations for great influence and authority, is not complicated by the special industrial fact that the resources involved are personal and subject to the risk of loss. It is in all the cases regarded as of national importance that resources should not be wasted or lost, and the desire for rationalisation appeals to this conception of general economy, but industry is unlike other administrations as regards the origin of resources, and the incidence of liability. It is necessary, therefore, to consider to what extent the evolution just described affects this liability, as distinct from the pure impulse to higher organisation; that is to say, what is the place of mitigation of risk, as compared with that of leadership itself, in the movement for combination.

Leadership may be got either by fighting it out, the 'method of bankruptcy,' or by some method of absorption in one organisation. It is one of the claims of the combination method that, whether by Trusts or Cartels, the latter is adopted, so that the fringe of smaller businesses is more humanely or rationally dealt with than under the former method. On the other hand, the maintenance of over-investment in this way is often the basis of criticism of modern combines, because somehow it must be a charge on the community through prices, so that it is asserted that it is not the rational way of creating system.

And on the other hand, leadership may be maintained by steps taken to prevent or impede the entrance of new enterprises into the field. Development is desired from within, so far as possible through the discretion of one governing body. It is held that this also is the rational procedure, by which industries will become systems of administration, and, as will be shown later, impediments on independent new enterprises have sometimes been imposed with legal authority.

It is Joint Stock which has made possible the evolution of the great concerns, and which has also made them powerful competitors, so that, it is said, an ever intenser incidence of risk is a fundamental cause of the combination method. But Joint Stock has also itself modified the risk element.

So long as an industry was in the hands of a large number of producers who were individual in the sense of finding their own capital, the competitive struggle, which destroyed a business, ruined individuals. There are modern instances of interference with this competitive result for this very reason, when an industry was still of that grade; for example, the remarkable scheme devised for the Greek currant trade, and known as the 'Retention.' As the ruin of individual small cultivators would otherwise have been the result, the Government organised a system of maintenance. But when the units of enterprise are Joint Stock Companies, liquidation does not imply ruin in the same way, because Joint Stock brought with it the method of distributed investment. In the case of failure, some people lose part of their capital; perhaps because some other investment of their own has been unusually successful. The ramifications of interests can now become very great, and the question, what method of creating industrial control is most rational, has to take account of this, in conjunction with the fact that profit involves a risk premium, and that these are the understood conditions of investment. By the fact of distribution of investment, the industrial risks of capital are to be contrasted with those of labour, since wage-earners as a rule can work for only one business at a time.

The same considerations apply to the entrance of new competition. Enterprises entering the field are not now individuals staking everything on little-known chances, but may be directed by and largely composed of individuals who are in that same field already, and who know a good deal of its conditions.

In a second degree, these modifications of personal risk appear, through the practice, also rendered possible by Joint Stock, of company investment. While the individual may distribute his direct investment, his risks are spread again by the system of mutual company holdings, a company in which he invests having done this further spreading for him.

While, therefore, the direction of an independent business does and must consider its shareholders as if they had no other investment interests, the intensity of risk in its final incidence is not fully represented by Directors' statements. What applies to shareholders, also applies to Directors as such. The 'spread' of Directors' interests is a very remarkable fact.

As distinct, therefore, from the pure desire to rationalise, that is, to organise industry in a systematic way under some kind of unified control, it is not easy to assign its right place to the 'revulsion against risk,' on which also the desire for combination has rested its case.

It is always necessary to distinguish between risks which a combination may have been formed to overcome, and such as it may have created by its own policy. In many notable cases the alleged struggle against competitive risks was not so much 'rationalising' as 'de-un-rationalising.'

V.

The foregoing considerations show that there is something to be said for capitalist evolution in the alleviation of risks ; so that we cannot easily separate the risk element from the simple purpose of leadership and wide control. This desire for more extensive control is a feature merely of active enterprise and ambition ; it has counterparts outside of industry. But as distinguished from, for instance, the tendency of public Departments to expand when they can, the mixture of risk with ambition is a special industrial fact.

The same is true, in a less degree, when the risks in question arise out of bargaining, not out of competition. Great industrial influence may be gained by the control of enterprises on different levels of production, which were not therefore formerly competitive. This comes into being as the last stage of the bargaining process, which is made closer by long contracts, exclusive contracts, and agreements for exclusive trade. Finally, the bargainers combine. There is something to be said historically for the view that such combinations have been formed defensively, if it is thought that horizontal combination on one level is exacting too high a price from producers on another level. Thus horizontal combination leads to vertical, and the former becomes split by the engagements of its members to deliver their supplies, not to the market, but exclusively to some further producers. The latter do not get their supplies by this method 'at cost,' but they get them free of the special combination profits on the earlier products. Thus a steelworks may buy up a coal mine in order not to pay the profits of a coal combine. These are incidents of industrial friction. But the permanent or rational aspects of this policy are again not purely industrial ; they are more generally administrative, while having this industrial application. It is natural for any great administration to consider the continuity of its relations with any supply on which it depends. Thus when a public Department takes over the service of education, it does not rely on the market to find a supply of teachers properly adapted to its requirements ; it sets about securing them by its own arrangements. Analogies can be drawn also from ecclesiastical and military administrations. It is in fact difficult in many cases to say what is a single process, and how far unity of supervision must extend. Apart therefore from temporary or accidental causes, many administrations have to extend backwards or forwards from their main purpose, and in industry this is called vertical integration. In some industries the technical advantages are more obvious than in others ; they appear to be greatest in the iron and steel trade. But broad considerations of administrative supervision may lead to its application in any case.

This form of combination, like the former one, may be undertaken for the simple purpose of leadership. But it creates this position only when the main administration is itself already so large as to give that position ; and it does not by itself create monopolistic influence. When it is mixed with a large degree of horizontal control, it approximates to the third great type of aggregated interests—the Concern.

VI.

Industry cannot be looked at only as a type of government, because of its special relation to risks ; but some of its modern developments are to be explained in large measure by reference to administrative ideas not peculiar to industry, and especially to the motive for extended leadership and influence. When we consider the 'Concerns,' we come to the case where technical economic reasons are least easy to assign. These have not the definite continuity of the other forms of control. They are of the nature of industrial aggregates or blocks. The interests which are thus grouped come within the control of one or a few single personalities who, because of the diversified nature of their influence, are rather magnates than leaders. Thus in the period of the German concerns we had the Stinnes, Thyssen, Kloeckner, Haniel, and Stumm groups ; and if, for instance, we examine the Stinnes group, we find that it includes iron and steel, special steel products, coal, electrical products, shipbuilding, shipping, chemicals, cables, aluminium, copper, automobiles, mineral oil, margarine, newspapers, fisheries, and hotels, and this is not a complete list. These interests are obtained largely by the method of holdings of shares, and the interests of one group may, within the same large enterprise, touch those of another, the ramifications being so numerous that it becomes difficult to say where one set of interests begins and another ends. The Concerns appeared in Germany in a time of great unsettlement, and their explanation—the sudden limitation of her resources by the Treaty, and the struggle to control what was left—is not a reason going back to economic considerations to the same degree as in the case of the other types. They do not appear to contribute to the solution of an economic problem, or to create a force of leadership for any permanent purpose of direction, and they cut across the lines of economic grouping. The Stinnes Concern broke down by complexity, and it appears that the remainder are being shaken out into parts which will adhere to one or other of the main lines of economic grouping and control. But grouping of this kind, on a lesser scale, is likely to continue, since it represents partly a type of ambition which is satisfied by variety of industrial interests, and partly the fundamental similarity of industrial finance, whatever kind of thing it is that is financed. It appears, from an official return, that 65 per cent. of the capital of companies in Germany in 1926 was in Concerns.

VII.

If we look at the picture which is being drawn by these forms of grouping taken together, it is something of this nature. On different levels, combination takes place by agreements or consolidations, that is, Trusts or Cartels in the usual sense. Though the aim of Cartels is to prevent the elimination by failure of smaller or weaker producers, in fact they tend to create consolidations, because they allow stronger businesses to buy up weaker ones, and thus to obtain their share of the allotted output. As Cartellisation extends, on each level there come to be predominant interests, and decided leadership. But cutting vertically across this are the combinations which terminate on a product in the higher stages, these combinations having considerable shares in the output

of lower products in a succession of stages. Of these lower products they use what they require for their own finishing processes, and put the rest on the market at Cartel prices. A strong vertical combination may have leading influence as regards both its final and its lower products. And dispersed in a less systematic way over the whole field are the holdings which any large business has obtained in enterprises not closely related to any main purpose. All these interconnections, made possible by the flexibility of the Joint Stock system, and disturbing to the theory of economic competition and prices, suggest a few broad conclusions.

First, the *capacity* of either management or direction is more difficult to limit than that of technical industrial equipment. How broad, or deep, an area of enterprise can be singly managed is a question to which all this development is the only answer. And *a fortiori* of direction. Examination of our own 'Directory of Directors' shows how widely this consultative responsibility can be extended, before reaching the limit of its capacity. One prominent personality has thirty-two directorships, thirteen of which are Chairman's positions, and three managing directorships; some of the enterprises involved are among the largest of their kind; the range covers coal, railways, telegraphs, tea, asbestos, assurance, shipping, banking, general merchandise, canals. There are many cases where over a dozen of such important positions are singly held. These great extensions of control are to be related to the impulse to use the powers of management and direction at full capacity. On the other hand, a public Department, with much greater routine, is supposed to be one man's job.

Second, the *authority* of business leaders will increase with the magnitude of their engagements. An example of this was the hurried endorsement of the proposals for international agreements between large interests, on the repeated plea that we must not be 'afraid of big business.' This became, with marked rapidity, the right thing to say, and almost official sanction was given to recent conferences of business leaders simply because the interests represented, and the plans considered, were on the largest scale. With authority of this kind it will become increasingly difficult to argue, or to contend against its claims that a measure of monopolistic power may be essential to a scheme of rationalisation. Industry being a field of more special knowledge than politics, the difficulty is greater of applying criticism to leadership; that leadership itself is more concerned with working out the administrative methods of higher control than with the question of its democratic position. 'I do not consider,' said one of the organisers of international industrial agreements, 'whether I may make these agreements; I go on and make them.' The relation of the community to this authority appears in the end to be determined by the expectation that scale of responsibility, and the labour of organisation required for these great industrial structures, will tend to make leadership, in the words of the Balfour Committee, 'imaginative,' and therefore considerate. It was in this expectation that the recent Committee on Selling Agencies in the coal trade reconciled the dilemma that what was necessary for high organisation would create the possibility of monopoly. And so Liefmann says: 'When one considers what efforts have been made in many industries to obtain combination,

to find its most purposeful form, to bring in the outsiders, to settle the differences; when he sees what time and trouble are applied, how many conferences held and rules drafted; and when he considers the earlier conditions where such common negotiation, making the inner details of management a matter of conference and publicity, would have been impossible, then he sees how the whole economic structure has changed, and how much the Cartels have revolutionised the whole basis of management and enterprise.' 'The sense of interdependence becomes stronger than the thought of economic opposition.' This defines the difference between magnates and leaders, and the rationalisation of authority.

Third, there will be the fact of mere *complexity*, whether modified or not by publicity. Industrial government permits of this in a degree not reached in the other great fields of administration, political, religious, and military. Its extent is shown, for instance, in the recent official German analysis of the cross-relations obtaining within and between the Trusts, Concerns, and Cartelled enterprises. This maze of interconnections may become itself a matter of distrust and prejudice from the side of the community, especially but not exclusively in its international aspects. This prejudice showed itself at the outbreak of war in a well-known case, described as an 'octopus' of private interests; or in the name, a 'King of rats,' applied to a control which has indefinitely extended underground accesses in all directions. Even if industrial finance is flexible enough not to feel anything unmanageable in this, the community, on occasions when such complexities are made public, is alarmed and disturbed, as if a march were being stolen on its market alternative, or Joint Stock practice going beyond the spirit of the law. Sheer complexity of relationships might be one of the influences causing opinion to move as far beyond the sanction of combination as it has recently moved toward it. Democracy likes at any rate to think that it understands how it is governed.

VIII.

With the growth of industrial leadership a change takes place in the relation of price determination to the dynamics of production. The change is one of emphasis, that is to say, of the degree to which prices are approximated to a cost of production. Under a strictly competitive economy, there are producers who are just able to come through the fluctuations of prices with an ordinary rate of profit, and these producers are marginal. There is an amount of production, not always in the hands of the same producers, which is extra-marginal, and of course another amount which is intra-marginal. The general conditions of supply and demand determine the price level about which the fluctuations take place, and therefore determine which producers are marginal. The extent to which extra-marginal, or high-cost, producers influence price depends on trade practice; it is less, the more production is 'to order,' and they can keep their position only by working at lower than ordinary profit. In other words, prices are not usually determined by the costs of the highest-cost product, but the profit on that product is determined by the range through which prices have fluctuated over a period; and high-cost product has constantly to move to a lower-cost production, or go out of the market. This was shown by the price-fixing proceedings

which took place during the war, and has been explained by those engaged in these proceedings, especially in the United States. It was there found that about 10 per cent. of the product was extra-marginal, and prices were therefore fixed so as to cover 90 per cent. of the output. The equilibrium was not easy to define, but it depended chiefly on the output, and the elasticity of the output, of intra-marginal producers. It may be said generally that business administration was exercised on the problem of costs in relation to prices, which were the ruling fact, and which decided how much of the capacity of output was within, on, or over the line of profitable production. It was always a mistake to argue, under these conditions, that there was a body of marginal producers who *determined* the price. So far as any producers did this, it was the largest, who were probably intra-marginal. All producers were, however, affected by the knowledge that, though expansions of their own output were possible and would be profitable if prices were affected by that alone, other producers would be competitively induced to do likewise, and so output was controlled by a sense of the market, which is a difficult thing to relate exactly to prices.

It is an aspect of 'rationalised' industry, on the other hand, that the price can be more properly regarded as the *instrument of an industrial administration*. It separates itself somewhat from relation to any particular cost, and takes priority over the output, the latter being adjusted so as to render a certain price policy possible. The leaders of a great combine act under the conception of an industrial development which is frequently defined as the adaptation of the whole output to the possibility of certain prices. This is seen in the details of the price policy of Cartels, where a margin exists between base prices and the 'accounting' prices at which the output is taken over from the members; and also in the use of 'guiding' prices in other cases. This instrumental use of prices is the result of the greater supervision which has been made possible by combination, and it causes the management to resemble an administration in which the methods of development are more capable of a general decision. If one looks at such great combines as exist in the tobacco or chemical industries, with their high degree of internal organisation and their external agreements, the management of the price will be a compromise between the interests of consumers, those of the standing capital, the provision of reserves for development, and contingencies. An assignable cost of production is less easy to set off against that price. In a sense, this means monopolistic influence; but monopolistic policy would be something else, the administrative idea of price policy being worked with a larger factor of compromise. It may be described as the 'Safety first' policy in industry. The defence of 'rationalisation' is just this difference between administrative and monopolistic prices, or at least the claim that there is such a difference.

In this administration strategic factors will always be involved, because industrial administrations will never be free from reference to competitive possibilities. The evolution of combines has shown that one limit has specially to be kept in view—the point of what may be called 'own production.' This is reached well short of monopoly prices. It depends on the parallel growth of combines on different levels of production,

each of which may use its resources to expand vertically, a development which is not always desired, but which has its point of preference to market dependence.

The administrative use of prices may also extend beyond the consideration of what will maintain and develop productive capacity in a particular industry. It has been claimed that strongly led combines may adjust their prices so as to assist the stability of industrial development as a whole. Thus a combine might, on a rising market, so advance its prices as to render expansion more difficult, and therefore so as to damp down that expansion. There are very few cases in which it can be said that industrial combines have applied this idea. It has been considered that this policy is applicable mainly from the side of the banks which, it is suggested, should move the price of loans quickly and strongly enough to deter speculative inflations of business, and reduce fluctuations. To keep other things more steady than they might otherwise have been, one thing, the price of money, would thus be less steady than otherwise. This policy is not inapplicable to industries which are as fundamental as banking—for instance, to the coal industry, on whose supplies expansion depends as vitally. It is, however, unlikely that any industry will have the same degree of combination for this purpose which the great banks have; and the relation of such a policy to their own costs is more complicated than it is in the case of money. Where price administration has been applied for this purpose, it has been in the form of price-stability, as in the case of the German Coal Cartel. It is natural that this simple method should be applied, and anyone can fix a price, especially near the top of a boom, as was done in that case. It is, however, price adjustment that is required, a more difficult proceeding, and not expectable in respect of industrial administrations beyond the necessities of their own internal stability.

IX.

The idea of a rational administration, in its relation to the 'competitive war' and to the monopoly 'problem,' may be otherwise illustrated. Liefmann, a great defender of rationalisation by Cartels, states that 'a Cartel without monopolist purpose is nothing at all.' It is to him a matter of definition that some common administration is to be possible. This is the reaction which he describes from the overdone system of individualism, in which the consumer was *tertius gaudens* at a concealed social cost. But it will be remembered that Cournot derived the competitive position from that of monopoly, by multiplying the monopolists. Historically, as well as analytically, it is conceivable that we might have worked downward from monopolies, instead of upwards from competition, in order to obtain the position now called rational administration. We might equally explain the facts on the ground that the monopoly motive is fundamental, and that it expresses itself wherever or so far as competition does not impede it; or on the ground that competition is fundamental, and always tends to break down or circumvent monopolist tendencies. From the former point of view, the more competition is unrestricted the less is the influence of *organisation*; working down from monopoly, as a unified organisation, competition appears as the limiting case, when all the parts fly apart and act independently. The latter standpoint gives monopoly

as the limiting case, and therefore *monopolistic tendency* as a description of less complete organisation. The conditions now sought for under the name of rational control are between these limits of pre-assumption, and may therefore be regarded as a departure from whichever end of the scale is pre-assumed as 'natural,' in the direction of the other 'extreme.' Those whose ideal is the completest regulation of an industry as a whole regard therefore the looser structure of the Cartel as not so completely rational as the Trust, as a lower *organisation*; while the still persistent preference for competitive conditions regards the Trust as monopoly and the Cartel as monopolist tendency. Comparing the method of Cournot with that of Ricardo, the 'letting down' of organisation with the 'building up' of monopoly, the idea of 'dissolution' with that of 'restriction,' we see 'rationalisation' as the endeavour to find the range between these limiting concepts of purposive leadership or industrial administration. Otherwise stated, there are restrictions on organisation as well as on production. Dismissal of the rationalising argument on the ground that it is 'another word for restriction' means that we are arguing under one of the pre-assumptions, that which has historically had precedence since Adam Smith. The farther from Scylla, the nearer to Charybdis, and *vice versa*. The middle way is open to both dangers, and to the fears of those who have become specialists in rock or whirlpool navigation.

X.

Reference may be made here to two recent contributions to the problem of extension of control, which in different ways place it in relation to the pre-assumption of independent competitive working.

It has been shown by Dr. Thorp¹ that there is a great variety in methods of industrial grouping, and that the 'power combines' indicate only the last stages of measures taken in a smaller degree to strengthen independent positions. He shows that most businesses are operated by a single establishment, only 7·4 per cent. of all establishments being in 'groups,' though this means a very much larger proportion of the output. Besides ~~those~~ groups which he calls uniform, in which the grouped establishments are of the same kind, and are 'horizontal,' and the vertical groups to which reference has been made above, he finds that producers defend themselves, on a small scale as well as on a large, by other forms of extension of control. There is grouping of convergent processes, when the same business makes complementary or auxiliary products—what may be called 'lateral integration'—so avoiding the risk that one product may be affected on the market by misfit to products used in connection with it; *e.g.* bedsteads and mattresses may be grouped for production. And there is divergent grouping when different products are made under one direction, because of a fundamental common material or process; *e.g.* because of common process, wire and hempen ropes are sometimes produced together. These four types of grouping show themselves in most cases on a small scale, and are the origins of what, in the largest cases, is called the 'rationalisation' movement. In over 60 per cent. of all the groups examined, there were not more than two establishments; in 4·5 per cent.

¹ *The Integration of Industrial Operation* (Washington, 1924).

of groups there were more than ten. The 'span' of these groups—the extreme distance between their establishments in the same country—may also be an indication of the *Machtfrage* involved; it was over five hundred miles in 17 per cent. of all the groups. Thus the desire for extended control arises out of small cases, as a 'rational' device on various grounds, though its theory and title have been examined only in its largest extensions.

An attempt has been made by Dr. Saitzew, of Zurich, to place the 'rational' development in a true perspective as regards both motive and structure, in a recent paper.² He uses the method of co-ordinates, placing along three axes points defining differences of *motive*, *instrument*, and *direction*, of grouping. Thus the motive may be pure monopoly, or

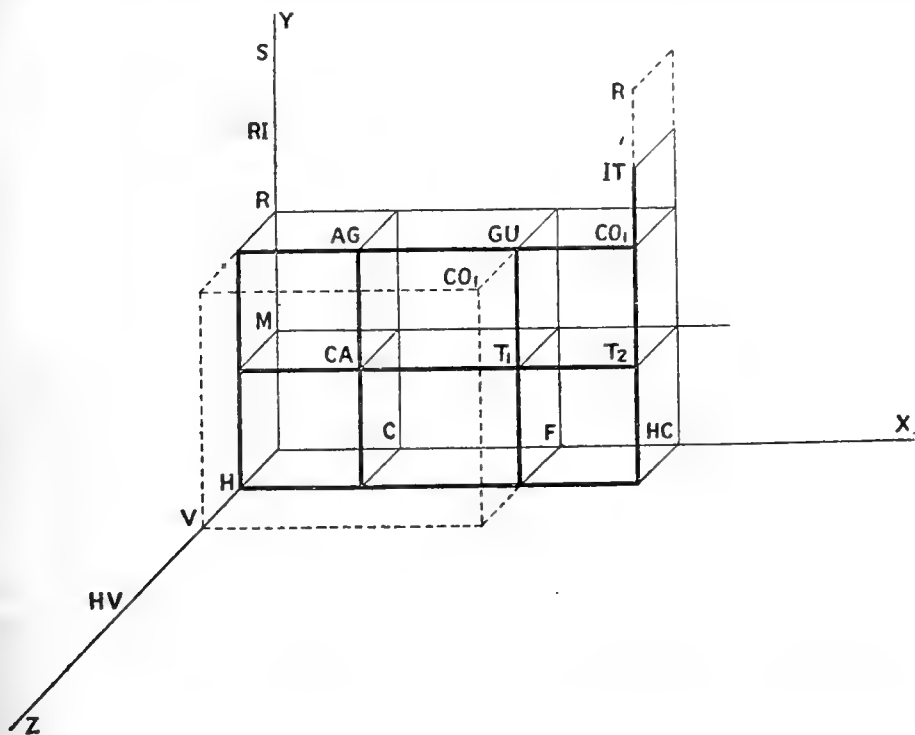

rational control, or avoidance of risk, or secret influence; the instrument may be contract, fusion, or holding company; the direction may be vertical, horizontal, or a mixture of these. It is thus possible to place in relation to each other the chief types of structure, and to classify on lines different from those of Dr. Thorp. Part of this classification is shown in the diagram, the instruments of Contract, Fusion, and Holdings being placed on the X-axis; the directions Horizontal or Vertical on the Z-axis; and the motives, Monopoly, Rationalisation, Avoidance of Risk, Secrecy, and so forth, on the Y-axis. On the monopoly level of motive there are Trusts (T_1 and T_2) and Cartels (CA); on that of rationalisation there are the 'organised association' (Arbeitsgemeinschaft, AG), the 'great undertaking' (GU), and one type of Concern (CO_1). It is an

² *Horizontal und Vertikal im Wandel der letzten Jahrzehnte* (Jena, 1927).

exercise in ingenuity to fill in other types. The combination HC, H, RI, gives the Investment Trust (IT); the secrecy motive S yields one of the 'Kings of rats' (R). There are various other forms of Concern. Dr. Saitzew has by this means done something to rationalise the argument itself. His method indicates the range of organisations, which is neither all 'monopolist' nor all 'rational.'

XI.

In the policy of rational industrial administration, as it is usually presented, restriction is involved, on the ground of the attempt to adapt production to a proper rate, to overcome duplication, overlap, or speculation, and to give control through leadership. There are some important cases where this policy is carried out under public auspices, and these involve an admission of necessary organised action, to which private enterprise on similar lines may appeal for a general sanction. Instances are the Brazilian plan for the valorisation of coffee, that is, the adjustment of sales under the instrumental use of prices; the British rubber scheme; the Greek 'Retention' in the currant trade; and the German control of potash. The last two of these may be specially noticed, as important cases of the refusal to let competition work itself out, but with some difference in the fundamental conditions.

The Greek Retention arose out of the fact that the currant crop is of vital importance in the export trade, and is grown by small producers. When the French vineyards were ravaged by the phylloxera after 1879, Greece supplied the deficiency, so that the currant was described as the 'saviour' of the wine industry. There was a great extension of plantation in Greece, the peasants being advanced loans by the State, and great prosperity till about 1890. Then France, having repaired her vineyards, killed the trade with heavy duties. There was so little elasticity in the 'pudding' demand of England, that prices fell ruinously and did not cover freights. The peasants were faced with ruin, and the Government with revolution in the Morea. It was therefore decreed that a percentage of the crop was not to be exported but retained at home, and this percentage had risen to 35 before the war. At first the Government, afterwards a Privileged Company, received this 'Retention,' to be disposed of at home by finding some new use for it, as currants are not consumed in Greece itself. The complicated arrangements would require a long statement, but they amounted to 'home dumping' on industries which extracted alcohol, or on the Greek wine trade, at prices far below the export prices. Heavy taxes were laid on new plantations, and funds were raised by the Company to compensate cultivators of plantations given up. All this was done against the opposition of those who contended that the whole idea was wrong, and that natural laws should work themselves out. The Privileged Company, getting 35 per cent. of the crop for nothing, was so successful that it was bought up in 1924, and the problem is still unsettled. But it shows the following features. The *control* was considered specially necessary, because the units of enterprise were individual peasants faced with ruin. The *organisation* yielded, for a long time at least, a solution, because organised effort was able to create conditions which would not otherwise have been possible. The new competitor

was restrained by taxes, and the elimination of surplus production was obtained by financial measures of compensation. The last three of these belong to the claim of private enterprise for rational solution of the problem of production.

The significance of the Potash Cartel is different in so far as the members were not individuals faced with ruin by competition, but companies. But it shows, under Government sanction, the working of the ideas of rationalisation in a very marked way. There had been a Cartel since 1879, but investment in this industry increased very rapidly, perhaps because of the Cartel, but also because of the agricultural demand. A great speculative period, the 'Kali fever,' broke out in 1898, the Prussian fiscus itself bought (according to Liefmann) an important works in 1906 for fifteen times the paid-up capital, and under such conditions there was immense over-capitalisation and excessive investment. In this, as in the Greek case, many persons advanced the view that the natural economic solution would in the end be the best; and in 1910 the larger producers, suffering from reduced quotas in the Cartel and consequent high prices, broke away and sold ahead to America at half the current prices. The Government considered the position dangerous to German agricultural interests. In 1910 a law was passed under which total production, quotas, exports, exchange of quotas, and prices were regulated. This law did not establish a compulsory syndicate, or create a monopoly, but in effect it made adherence to the Cartel necessary. The important rationalising feature was that new competition could not arise except on disadvantageous terms, the output of such works being by the law subject to special limitation for a number of years. In 1919, as the result of war conditions, the number of producers had increased to 200 (having been 68 in 1910); and the prospects were so serious that compulsion was applied by a new law of 1919. All producers were now compelled to join the Syndicate, which became the executive organ of the Federal Potash Council, with which, and its organs, final supervision lay as to prices and policy.

The special application of rationalisation under these auspices is in respect of closing down, and of the growth within the Cartel of the largest interests. Closing down could take place voluntarily or compulsorily. It was decreed in 1921 that owners who declared by a date in 1923 (later extended to 1925) their willingness to close down and keep closed till 1953, were to retain their quotas; that is, they would receive their proportion of profits exactly as if they had delivered their supplies. Compulsory closing down is based on 'proved permanent uneconomical working,' the compensation being similar, but on reduced quotas. At the end of 1925, out of 224 shafts in existence, 118 had been definitely closed till 1953; 71 were at work, and 35 held in reserve. The shafts closed down represented 441 of the 1,000 quotas of the Syndicate. Within the Syndicate, combination by exchangeable quotas, a main method of rationalisation under Cartels, has given a dominating position to two large groups.

It is unnecessary to comment further than to say that to carry on prices 44 per cent. of idle capacity is a proposition only possible because of Germany's virtual monopoly of this product. The case against 'Ricardian rationalisation' was not a strong one. But it will be seen

that a sanction is provided by such strong instances as these for the proceedings which define as rationalisation the inclusion in a new private enterprise of the whole fringe of excess capacity, *plus* the endeavour to counteract this diseconomy by the further rationalisation of grouped interests under strong leadership.

XII.

It was pointed out earlier in this paper that the whole question was thrust on public notice by the recent argument on the international extension of grouped control, bringing strongly into prominence the influence of industrial leaders in their own countries. They had obtained a leadership which enabled them to speak for their own nations in these arrangements. This authority, derived also from the impressive magnitude of the international plans, imposed on public opinion nearly everywhere an attitude of assent, so that in a sense these leaders 'got away with it' in their claims for rationalisation by Big Business. But whatever may be thought of the system of grouping and leadership on a national basis would not necessarily apply internationally. A community may accept the evolution of competition into a type of industrial administration, relying always on the foreign market for limitation of monopolistic policy. When this guarantee is endangered, it may go back on its assent to national combination *under purely private leadership*.

For example, it is a usual form of international agreement to 'respect home markets,' and this in effect creates prohibitions on trade which are greater than the considered fiscal policy of the country was prepared to allow. It is argued that tariffs thus become 'superfluous,' a designing expression which can scarcely have deceived the distinguished writers who have used it. The suggestion to rationalise international production by giving to private interests a treaty power overriding that of the Governments concerned, compels us to consider in what form such international relations are compatible with any system of domestic combination.

There is, of course, a wide extension of what may be called 'direct international capitalism,' through the creation of foreign branches and shareholdings. These do not create the problem just referred to, which only arises out of *agreements* to restrict output or markets, and so endangers locally the conditions of the consumer.

A distinction may be introduced here between two types of agreement with the aim of rationalisation. There are those which are called 'agreements for conditions,' and those which are more directly restrictive of volume of output and sale. Examples of the former are given by agreements on length of credits, or for standardisation of types, or against rebates on price. But perhaps the most notable instance is that rationalisation of the conditions of competition which is known in the United States as a 'trade practice submittal.' If there is any practice which may be considered unfair—as in the case where various wares were marked 'Sheffield steel' though produced anywhere—the firms in the industry may be called together to a voluntary conference by the Federal Trade Commission, and an expression of opinion obtained, which practically establishes a law-merchant for the industry. This is an agreement on conditions of trading, with no other limitation on competition, and

there may be scope for international agreements of this nature to which no exception could be taken. Thus an agreement against dumping might be negotiated, to overcome the ' falsification of the market ' and the instabilities which dumping creates ; or an agreement for the exchange of patents, or for the organisation of trade information.

It would seem that acceptance of the claims of combines to rationalise within national limits would be easier if on the international level inter-combine agreements were of this type of ' Cartels of Conditions.' Otherwise, instead of international agreements leading *a fortiori* to the justification of national combines, they are likely to diminish the consent to, or increase the legal supervision over, them. The chief instability of the present position lies not in the formation of international agreements of the recent type, for these have existed for over twenty-five years, but in the realisation in the last few years of possible undemocratic extensions of industrial authority and leadership.

XIII.

So far, the ideas of rationalisation and leadership in industry have taken account only of relations between producers, as the heads of organised units of enterprise. But the membership of an industry includes the great body of workers who are subject to this leadership, and it remains to show the bearings of the argument for ' rationalisation ' upon them.

As a defence of the Cartel system in this respect, it has been argued by Liefmann that the dangers of ' instrumental ' price policy to the position of wage-earners as consumers are continually being lessened by the growing participation of labour in prices, through its own combination. It has an increasing producers' interest. Or otherwise, the same argument has been put by one great industrial leader, who states that there is practically no pure consumers' interest except that of the *rentiers*, and these are not to be too seriously considered against plans for a more rational organisation of industry. It is, however, too summary to dismiss the labour question involved in this way. Even if we consider labour under the broad general name of producers, it is obvious that there is a degree of restriction which will affect them all without compensation, there being fewer goods for the whole wage-bill to buy. And if we allow for the diversity of kinds of producers, it is also evident that Group A may penalise Group B, and *vice versa*, and that it will be difficult to follow the incidence of various group restrictions, though easy to show that there may be a great spread of injurious reaction. The post-war wage position in this country is largely due to such reactions between groups. A general defence in these terms of the restrictive aspect of rationalisation policy is open to Yves-Guyot's pertinent question—' *Qui restreindra la restriction ?* ' Against the debit of producers' restriction, it is not a set-off to credit labour combination, since the right way of distributing the product, and the right rate of production, are independent questions. So far as rationalisation implies restriction, it has to commend itself to the working-class community for reasons against which existing rights of bargaining are not offset or debited.

The aspect of rationalisation in which labour is interested as a *further advance* is that of control. By this is meant the sharing of administrative industrial control by labour as such. There are various methods by which shareholding may be extended to employees, but in the cases where such holdings give a share in administrative control they imply that the labour qualification is not itself adequate, and that employees must qualify as capitalists. Copartnership schemes have their own place in schemes of industrial progress; but the question is different, how far on the basis of work alone it is rational to distribute shares in control.

The existence of organised wage-bargaining is not a solution of this question, because it relates mainly to the terms on which labour is sold or delivered. The terms of delivery—that is, the conditions of work—are pushed up to a margin called by Mr. Goodrich the ‘frontier of control’; but this, while it compels the management to make some internal arrangements concerning employment, is at its utmost rather to be compared with terms of sale and delivery of products between their consumer and producers, the sellers not thereby entering into the buyers’ administration of their own concerns. This has nowhere been more clearly put than in the first clause of the Engineers’ Agreement, which stated that ‘the employers shall not interfere with the proper functions of the Trade Unions, and the Trade Unions shall not interfere with the employers in the management of their business.’ This was called the ‘General Principles of Employment.’ It implied two administrations, related as buyer and seller of a service.

The difficulty of overcoming this dualism within the individual business is that of obtaining any equation between units of labour and capital. The idea of a franchise implies a basis of qualification, and in this case a rule for equating a certain amount of labour of a certain grade to a certain holding of capital. This is the point taken by the exponents of the New Zealand Companies Empowering Act of 1924. By that Act it is possible to issue ‘Labour shares,’ entitling the holders to full voting powers, but Companies have themselves to decide what is the right distribution of these shares in relation to those of the holders of capital. It is very difficult to see a basis of general application.

It should be pointed out, however, that the idea of control by some kind of industrial franchise is one carried over from politics to industry, and that industry is not alone in not having hitherto applied it. Such other fields of administration as the Army and the historic Churches do not proceed on this method either. The conditions are not regarded as being such as to place these spheres *in pari materia* with politics as to their fundamental principles of control. Many criticisms of industrial structure in this respect come from sources where authority is a much more marked feature of administration than it is in industry.

Difficulties of this kind arise mainly when the question is of a share in the control of individual businesses. A solution within that sphere may be found in time along the path first broken by the New Zealand Act. Meanwhile, however, the process of industrial grouping for the purposes of technical rationalisation does itself tend to make possible a degree of rationalisation as labour understands it. For it creates units of enterprise which are on the same scale as labour organisation, that is,

which extend over a large part of an industry. Trade Unions have been suspicious of attachments of labour to capitalist government within individual businesses, but these objections, it may be suggested, would not be so serious against the representation of organised labour on the government of great combines. The fact that scale of working corresponded to size of organisation on both hands, besides removing the labour objections to sectionalism, might also shift the problem of qualification from an individual to a mass basis, the participation in control being that of representatives, and settled on some broader view of rights of government. It is a feature of the most organised syndicates in Germany that this participation in the general control has been obtained for labour representatives. The horizontal combines, rather than the Concerns, are obviously the most favourable sphere in which to proceed for this purpose. It is to be admitted that the problem of qualification, while simplified, is not solved. For purposes of bargaining the rule is equal representation, whatever the relative importance of the parties. For purposes of government, in this field, relative importance must count. Great combines render a solution more possible, and also more urgent. Some great fundamental industry, combined either voluntarily or, as in Germany, by law, might develop a solution by the method of trial and amendment.

Finally, rationalisation by industrial grouping and leadership may enable a further step to be taken in respect of industrial peace. Our present resources for this purpose, on a voluntary basis, are very complete; but if there is a gap, it is in respect of a method of assuring continuance of work while negotiations proceed. The coal subsidy was of this nature on an unusual scale. In respect of wage disputes in fundamental industries, it seems to be a possible addition to our methods that, when negotiations have narrowed the issue to its smallest difference, and there is yet no agreement, the disaster of stoppage might be averted if the Trade Union could be enabled, pending an arbitration, to advance to its members the whole or a part of the difference in question, subject to guarantee of being refunded as much of its claim as the award sustained. This might be called the method of 'continuation pay.' It would always be less than strike pay, since the latter is about two-fifths of wages, while the difference in dispute would not often be as much as half of that. The Union would therefore suffer less even if the award went entirely against it. There is some approximation to this method in the occasional practice of ante-dating awards, but the community is not thereby cleared from the loss of a stoppage. If a step of a new kind can be taken, it is by way of making 'continuation pay' a practicable thing. Now the higher organisation of industry does contribute to its practicability, since it enables a more complete guarantee to be offered from the side of employers. It may therefore contribute to a 'rationalisation' in industrial relationships which would be of great benefit to the community, the more so if some working solution of representative control had been also applied. On this note these considerations of the bearings of the new tendency may be concluded.

SECTION G.—ENGINEERING.

INVENTION AS A LINK IN SCIENTIFIC
AND ECONOMIC PROGRESS.

ADDRESS BY

PROF. SIR JAMES B. HENDERSON, D.Sc.,

PRESIDENT OF THE SECTION.

Introduction.

I DESIRE in the first place to thank the Engineering Section of the British Association for the great honour they have done me in nominating me as their President. Situated as I have been for many years as Professor of Applied Mechanics at the Royal Naval College, Greenwich, engaged in Naval Research work of a confidential type and lecturing upon confidential matters, then more recently acting as Adviser to the Admiralty, it has been very difficult for me to take as great a part as I would have liked in many of the proceedings of the Engineering Technical Societies to which I belong, because the line of demarcation between confidential and non-confidential matters is very indistinct, and anyone dealing constantly and indiscriminately with confidential topics and problems as part of his ordinary everyday life, particularly as a teacher, may very easily overlook in public the position of this line. To such a man safety lies in silence.

The British Association, by the width of its scope, the diversified nature of the papers read at its meetings and the broad line of treatment of the subjects dealt with, has provided me with an opportunity for contact with problems in many branches of science and an opportunity which I have greatly valued to meet scientific colleagues in a social or technical manner. I appreciate very deeply the kindly feeling which has suggested my term of office as President in spite of the fact that I have had little or no training for such an office, a defect which makes it necessary for me to rely upon the indulgence of the Section to overlook my shortcomings. To my good friend Professor Lee, the Recorder, I am greatly indebted for valuable assistance and guidance.

It is a matter of particular personal pleasure that my term of office should occur at the Leeds Meeting, and more especially that it should be associated with the buildings of Leeds University, because it is just 33 years ago since I first entered these buildings, which were then the Yorkshire College of the Victoria University, as assistant to Professor William Stroud in the Department of Physics and Electrical Engineering. I had finished my graduate Engineering course at Glasgow University two years before, had spent one year doing research work with Lord Kelvin and another year in Berlin University under Helmholtz, Planck, and the coterie of distinguished physicists at the Physical Institute at

that time, where I had absorbed the congenial atmosphere of a research school and had hoped to spend the rest of my days in such surroundings.

The sudden change to a modern University like Leeds, where every day and every hour of time of both students and staff were determined by rigid programme, was a great shock at the time, but I now realise that it was an excellent training and I shall always be grateful for the kindness which I received from Professor Stroud and the wonderful example which he set of conscientious devotion to duty and sacrifice of many of his scientific ambitions for the good of his students. I have thus many pleasant recollections of the four years I spent in these buildings and of the many friendships I formed here.

Invention as a Link in Scientific and Economic Progress.

Invention and Discovery are so closely allied that they are often confused. In our common speech the two terms are frequently used as synonymous, and if one seeks an exact line of demarcation between them one finds it difficult, if not impossible, to distinguish one from the other in any but the most general terms. Both involve an increase in knowledge which may be great or slight, and may have an immediate effect or may take a lifetime or more to consolidate. Both involve scientific imagination. Each may be only a happy idea, the inspiration of a moment or in some cases an accident, but the testing of the idea and its final enunciation as a physical truth or as a finished invention may occupy many years. Newton is reputed to have discovered the theory of gravitation on seeing an apple fall from a tree, but assuming that to have been the birth of the idea we know that the completion of his discovery and the proof of the universal law of gravitation took the best part of his lifetime and involved the invention of new branches of mathematics to complete the proofs. The record of Newton's work has been so ably revised during the past year by Sir Oliver Lodge, Professor Turner, Sir Frank Dyson and others, in connection with the Newton Bi-Centenary Celebrations, that these matters must be fresh in the memory of all.

Were I asked to distinguish between discovery and invention I would say, in very general terms, that the dividing line is the same as between theory and practice, between the abstract and the concrete. Discovery is essentially an increase in man's knowledge of nature and its complexities, and is therefore intangible. It may be a discovery of a new principle, a new element, a new and hitherto unknown quality or characteristic of a known substance, and so on, but the discovery, *per se*, has no regard to any particular practical application of the new knowledge. Invention, on the other hand, has its sphere in the practical application of knowledge, and the knowledge used may be new or may be as old as the hills. It may be, and it is often the case, that invention involves other discoveries which may be complementary to the original discovery and form its completion, or may be entirely unrelated to it and form the nucleus of a new branch of study. It is possibly this fact, that the difficulties encountered in developing an invention often lead to new discoveries, which makes it so difficult to separate discovery from invention. I think, however, that this distinction in general terms is sound, that discovery is mental while invention is material, and while it is true that in the large

majority of cases an invention is in its origin a mental conception, it is a conception of something material and practical, while a discovery begins and ends in the realm of the mind.

Discovery and invention are important links in the chain of progress but neither marks the end of the chain. The discovery has to be proved or the invention has to be reduced to practice. This brings in a third link, finance. The Einstein Theory, for instance, could never have been tested and established without the assistance of capital to finance the extensive eclipse observations which converted it from a pure mental conception to a working theory. The assistance of capital in the development of great inventions of recent years is a necessity too well known to need description.

Here then we have a series of operations. First comes the fundamental discovery laying bare one more of nature's secrets; then invention turning the discovery to practical use; and lastly, the hand of finance to help dreams to come true. The first is a matter of genius or inspiration coupled necessarily with deep study. The second needs skill in the arts and crafts and generally a high degree of patience and courage to weather the disappointments and setbacks which we are too prone to call failures. The last, though it may be allied with technical knowledge, requires most of all the commercial instinct to sense to-day the needs of to-morrow, coupled with faith in the invention and the inventor and courage to see the task through to the end. We are often told that the financial world of to-day worships above all things a fat and speedy dividend, but when one thinks for a moment of the amount of capital that must have been spent, often fruitlessly, in financing the discoveries and inventions of the past and realises at the same time the number of other channels open to finance in its own immediate sphere, offering possibly greater certainty and speedier returns, it is surprising, not that it is so difficult to obtain finance for a pure scientific invention, but rather that it is possible to find it at all. It says something for man's imagination that finance with its many other opportunities is willing, even to a limited extent, to place its resources at the disposal of scientific progress in the courageous belief that it is casting its bread on the waters of knowledge and that in good season it will return.

When one seeks to study the history of some of the great inventions, one begins to realise how exceedingly complex they are, despite their outward appearance of simplicity. As an example, take wireless telegraphy and telephony. No single person deserves the credit for its discovery and invention. Maxwell, Hertz, Lodge, Crookes, Branly, Marconi, Jackson, Fleming, de Forest, Fessenden and many others have contributed their share to its development, but the basis of wireless communication did not necessarily begin with Maxwell. What was it caused him to conceive the idea of the electro-magnetic theory of light? Most probably he was trying to explain, like many others, the experimental fact that the ratio between the electro-magnetic and electrostatic units was the velocity of light, and having conceived a possible explanation he proceeded to work it out and test it, and the electro-magnetic theory was the result. The original idea may have been a lightning flash of inspiration, but the complete mathematical theory was the work of years.

Hertz was the first to produce apparatus for transmitting and receiving wireless waves, and this apparatus was improved by Branly, Lodge and many others, but for further progress finance was needed. The first steps to make a wireless telegraphic installation were taken in Italy by Marconi and in Great Britain by the Admiralty experiments carried out by Admiral Sir Henry Jackson, who was then a Captain. In this kind of competition money counts for much, and in the development of an invention having a commercial as well as a service aspect a commercial firm with good financial backing will always have a great advantage over a Government Department with a strictly limited Budget allowance for research. It says much, therefore, for the scientific direction of the Admiralty of that time that the Admiralty are to-day numbered among the pioneers of this great invention.

I have taken wireless as a typical illustration. To the man in the street it represents simply an invention, a single invention and an apparently simple one represented by a small wooden box with a knob to turn. But to the scientific historian who tries to decipher all that the little box represents in human thought and effort, it presents an appearance of amazing complexity in which the discoveries and inventions of some of the finest brains of two centuries are inextricably blended. The proverbial tree of knowledge is a good simile. It grows incessantly but imperceptibly, sending forth new shoots which in turn become branches and subdivide in their turn. Growth is not confined to the shoots, however, and a continuous process of consolidation and expansion is taking place in the trunk and root and branches. The sprouting of a new shoot is a new discovery and the consolidation work behind it and upon which it is based is invention.

Invention as a Historical Science.

Invention being generally concerned with the application of physical forces in the service of man may at first sight appear to be a branch of physical science pure and simple. It is, however, actually concerned less with the scientific principles of physics than with the human element, with limitations which that element imposes, with peculiar conditions under which the forces of nature have to be applied and with the unknown elements in physical science. It belongs, therefore, if treated as a science, by itself, rather to that group of sciences which are concerned with humanity and nature at large, the so-called Historical Sciences. Economic Science, a typical historical science, is studied by thousands as a science, yet it has no fundamental physical principles like the conservation of energy on which to build its superstructure, because its working material is the human element which has not so far been reduced to any fundamental basic principles worthy of the name of laws. It is in what Lord Kelvin would have called the Natural History stage of its development, during which observations are made and correlated, to be followed by the Natural Philosophy stage when the fundamental principles are discovered which explain the observed facts and cast upon the scientist the mantle of the prophet.

A historical science which is studied at great length in the Staff Colleges of the Armies and Navies of the world is the Science of War. It has no

fundamental scientific physical principles as basis but is founded simply upon deductions made from a close study of warfare from all times. Wars are analysed, tactics and strategy studied with the view to learning from the history of centuries of war useful lessons to guide the soldiers of to-day and to safeguard them against repetition of the mistakes which have caused the disasters of the past.

The science of invention is a curious blend of the exact sciences, like mathematics, physics and chemistry, with a historical science. It is in many respects similar to the science of war, the war being against the complexity of nature, man's ignorance of that complexity and the inefficiency and insufficiency of the human intellect itself. Whether Nature be regarded as a cantankerous old dame ever ready to take advantage of a false step, neglecting no opportunity to obstruct, and resenting every attempt to reduce her movements to law and order, or whether she be regarded as a kindly old lady in the middle of a sun-lit lawn, calling softly 'Come and find me' to a crowd of eager, blindfold children, the fact remains that she and man are age-old opponents in a contest from which there can be no discharge to the end of time. Yet if we compare this contest with the wars of man with his fellow-man, what a difference we find. Napoleon said he learned the art of war from a study of the lives of the Great Captains, but in the greater war with nature if we consult the books that have been written round the lives of its Great Captains we find only human documents in which the searcher after knowledge, to help him to carry the fight a little further, finds little help beyond an example of high courage. The technical difficulties are seldom recorded and the new searcher has generally to start afresh and reconnoitre his way across the old battle-ground of centuries. The fault sometimes lies with the chronicler but too often with the lack of records which the Captain might have left but failed to leave. In fact here we have a startling lesson from the science of war, for is it not drummed into every budding soldier till it becomes second nature when he attains command, that one of his first duties in the field which must never be neglected is to maintain communication and pass on all information that may come his way, whether it be useful to him or not. The lesson has two sides. The soldier knows that he may become a casualty at any moment and the information which he gleans may be of vital importance to enable someone else to carry on in his stead, also that information which may appear unimportant to him may prove to be the key to the movements of the enemy elsewhere of which he is in entire ignorance.

Any invention starts with a scheme which, on paper, promises to be successful if the fundamental assumptions or information on which the scheme is based are correct. Just as a general draws up his scheme of attack based upon certain assumptions or information regarding the enemy's disposition, numbers and probable future movements, so the inventor lays his plans to curb and control nature by a scheme based upon assumptions as to her behaviour. When the general finds that the enemy is stronger than he thought, or that he has shifted his ground and is turning his flank, or generally that the enemy is not playing the game which he had been expected to play and which had been provided for, he has to modify his scheme and proceed on new lines, so also the inventor has

frequently to change his plans on discovering that Dame Nature is not quite so simple as he had believed and is seemingly getting the upper hand and laughing at his efforts to control her. So the fight goes on from day to day, from year to year, and there are very few great inventions which are brought to a successful issue without departing in some respect or another from the original scheme and without the expenditure of many years of effort and large sums of money. The records of the various attacks and their results in the series or chain of manœuvres which are finally crowned with success are rarely written, and in the much larger proportion of long engagements which are finally abandoned as failures no record of any kind is published and most valuable information is lost for ever.

Contrast this with military or naval wars in which records of every little move are faithfully kept and are studied by the historian, who draws from them lessons for future generations of soldiers.

The history of the nineteenth century and the enormous economic and political progress made in it might be summed up in the word 'Invention.' As was pointed out so clearly in Sir John Snell's Presidential Address to Section G of the British Association at the Oxford Meeting, economic progress can be best measured by the amount of horse-power used per head of the population, and since every successful new invention increases this amount both in the manufacture of the gear itself and by the power it may control, it is very evident that economic progress is closely allied with invention. The invention of the steam engine, the spinning jenny, the power loom, the steam ship, the power printing press, the dynamo, the electric lamp, the steam turbine, the electric telegraph and wireless telegraphy, not forgetting the chemical industries, form the economic history of last century, yet no one, so far as I am aware, has studied the development of any of these inventions with the view of learning therefrom and recording lessons which can be passed on to posterity.

Of the hundreds of inventions which have been abandoned as failures, or of possibly revolutionary inventions left incomplete simply from lack of capital or lack of courage, no record is available to those who come after and who might carry them on to success. Has every inventor for all time to start from scratch? The same difficulties crop up time after time in the development of inventions, yet every new inventor has to tackle the difficulties *de novo*, and fortunes are wasted in the process. Development of an invention is always costly, even when guided by all the experience obtainable from allied inventions; how much more costly it is when not so guided the history of the failures would most surely show. In most inventions there comes a time when the inevitable question arises 'Shall we cut our loss or risk further expenditure?' If the decision is to cut the loss, the invention, which is possibly a sound one and of great value, is pronounced to be a failure and the result may be the loss of an industry to the country or a delay in its introduction for many years. Science will prevail in the long run, but the cost of the trials both in time and money could probably be greatly curtailed if records of similar ventures in the past were available. Inventors would gain much if they could be trained in, and benefit by, the experience of their predecessors in the same field, while masters of industry, with records of that experience before them,

would be better able to appreciate the difficulties of the inventor and to co-operate fully with him.

No one would dream of putting a general in command of an army who had not previously studied the art of war either in Staff College or in the field, nor would they put an engineer to construct a bridge unless he had some experience in bridge-building; yet in the development of an invention some seem to think that no previous experience is necessary and the work is frequently left to the inventor himself, who may have no knowledge of the practical or commercial side of development, or it may be given to someone who has no previous experience of similar development but who is supposed to be a good practical man, though devoid of scientific knowledge of the principles to be followed.

In the development of inventions no general rules can be laid down because inventions take so many different forms, and the expert in developing inventions, say, in the chemical industry, would not offer an opinion on the development of inventions in complicated mechanism. Why is it that chemical reactions which work well in the laboratory on the small scale in vessels of glass or platinum so frequently go wrong when tried on a larger scale in works in vessels of porcelain or the baser metals? The expert in developing inventions in the chemical industry has had much experience in overcoming these difficulties, but little of that valuable experience has been published.

In every industry one finds that the experience thus gained in developing the inventions of the industry is guarded as a most valuable secret. The result is that this knowledge is not recorded and often dies with the individuals who possess it. Future workers even in the same industry have to pass through the same or similar experience to regain the lost knowledge and the whole condition is economically unsound. The expense to the nation which it entails must be enormous. It retards progress, it adds greatly to the time and expense of developing other inventions, and it brings invention into disrepute because so many firms have lost money in trying to develop inventions which have had to be abandoned simply through inexperience.

The value of experience in any particular line of invention is that it puts the owner of the experience in the position, when called upon to express an opinion on a new invention, to form an estimate of the type of difficulties likely to be encountered and the time and expense likely to be required to surmount them. The novice always underestimates both the difficulties and the cost of development, and many failures are due solely to this underestimation, while the man who has once been bitten tends to overestimate them and to suspect difficulties where there are none, with the result that the development of the invention is unnecessarily delayed.

Nursing an Invention.

So far I have dealt with the sequence of operations of discovery, invention, and the financial and technical assistance in development, but the process does not stop there. Once an invention has been developed and made a commercial article, it merely enters upon a new phase during which it requires the most careful attention. It requires nursing. It may be sold to users who are free to submit it to any use or misuse they

like, and even when properly used trouble is sure to arise somewhere and it is usually difficult to say whether the fault arises from legitimate use or not. This is a most critical financial stage because the invention, if put on the market too soon or without full experience of every detail, may be killed by financial failure due to faults introduced often by an ill-considered change of design at the last minute which may be very expensive to rectify. Everyone who has taken a close interest in motoring during the last twenty years will remember many mistakes of this kind which have retarded progress and have increased the cost of motoring, because in the long run the user pays for the mistakes of the industry.

The type of man required to deal with the problems which arise during this nursing period is not necessarily the same as in the period of development. In the latter nature is the only enemy, but in the nursing period every user is a potential enemy and has to be treated accordingly. The nurse must therefore possess tact and a knowledge of human nature. He must, in fact, be a diplomatist, but he must also be able to deal with the technical side and accept responsibility where it is called for.

Every firm, even after it has been turning out its products for years, will occasionally turn out one with a serious defect. The prompt recognition of that defect, its admission as a defect and its quick replacement free of cost to the customer makes a friend of that customer for life. On the other hand, failure to recognise the defect, any attempt to throw the blame on to the customer and any parsimonious treatment of the remedy will make an enemy of that customer, and his friends, which is much worse than never having had his custom.

The financial success of James Watt's engine was as much due to the nursing of Murdoch during this critical period as to Watt's own efforts in inventing and developing it. In fact the history of James Watt's engine is typical of most successful inventions. We have Watt, the typical inventor, interested only in his science and living for it, in a happy combination with Boulton, its promoter and supporter, and Murdoch, the born nurse and improver. Three different types of men all contributing in different ways to one great advance in civilisation, possibly the greatest single advance in the history of the world.

Boulton must have been a very patient man to continue for twelve years financing the experiments of Watt before the engine began to be taken up by colliery owners, and when Murdoch, then a youth of 23, joined them in 1777, the work he proceeded to do was of a type for which neither Watt nor Boulton would have been suited. Smiles has written of Watt 'He was not the man to fight the selfishness of the Cornish adventurers. "A little more of this hurrying and vexation," he said, "will knock me up altogether."' Murdoch, then only 25, went into Cornwall and gave himself no rest until he had conquered the defects of the engines and put them into thorough working order. He became friendly with the Cornish workmen and engineers. Indeed he literally fought his way into their affections, for one day some half-dozen of the mining captains came into his engine-room at Chace Water and tried to bully him. Murdoch stripped, selected the biggest and set to with his fists. In a few minutes Murdoch, victorious, was shaking hands with the lot of them and they parted the best of friends. I quote this little incident merely

as illustrative of the man and of the times and not as an illustration of what is required of a man called upon to nurse an invention in these more peaceable days.

The Inventor and the Promoter.

Since I have touched on the chief characteristics required in the nurse of an invention, it may not be inappropriate to refer also to the characteristics of the two other members of the trio.

In the Ordnance Department of the Admiralty there is a coloured cartoon of a man with an emaciated body, an enormous head of the encephalitic type, and wearing very concave spectacles, demonstrating a precious invention to a Jack Tar, all muscle and little brain, carrying an enormous spanner in his hand. Below it is the motto from 'Our Fathers'—

'The optimist inventor should remember if he can,
'Tho' the instrument is perfect, there are limits to the man.'

That cartoon is perhaps typical of the attitude of many men towards the class of men known as inventors. It is an attitude which is as old as invention itself and will persist probably until the end of time. The inventor's point of view, however, is that with the aid of invention there are no 'limits to the man.' It is his whole object to eliminate the limitations of the human element by giving to man the control through relay mechanisms of power infinitely greater than his own and with little or no expenditure of effort on his own part. The history of the past century shows that he is succeeding beyond belief. His success will continue and is bound to have a marked effect on the type of man of the future.

The highest type of inventor is first of all an artist with a vivid imagination in certain and possibly limited directions. Like the painter he conceives a mental picture and the picture grows as he proceeds to develop it. Like most artists he is unconventional and as a rule diffident except, naturally enough, in his own particular sphere. Unless he possesses also the gift of clear exposition he cannot expound his invention and make clear to others the mental picture he has created. Such a man has little chance of working out his ideas and making his inventions commercial propositions without the assistance of a promoter.

The promoter is a man of means and imagination who generally knows something about inventions or the branch of industry to which the invention relates, and is prepared to risk his capital in backing the invention. It is only natural that he should back only the inventions for which he can himself see a field of usefulness and be chary of those which he considers comparatively useless or unlikely to provide him with an adequate return for his risk. The great promoter is the man of vision who is not content to finance minor inventions for improvements in a known industry, but launches forth into the blue in support of an invention, unknown and untried, like the first steam engine or the first iron ship, and cares nothing for the sceptical criticism of the multitude who foretell disaster simply because the invention is something beyond their ken.

Much of the success of the great inventions of history has been due to happy combination of inventor and promoter, as in the case of Watt

and Boulton, and many are the instances where failure has been traceable to lack of this same combination. Its absence must, at the very least, contribute very largely to delays in development and to the impairing of a success which might otherwise have been complete.

Invention and Industry.

The history of the twentieth century shows clearly that Invention is the heart of Industry, the root of new developments and the source of improved methods of production which have led to cheaper costs and a wider scope in every industry. It has also been the cause of some of the greatest social upheavals and strife. Innumerable strikes have arisen from it, and if there is one lesson in political science more potent than another to be learned from the history of such movements, it is that science is always victorious in the end. Progress may be delayed or an industry may be lost to a country temporarily or permanently by such strife, but the steady advance of the world's progress through the science of invention is certain. One country may lose, but the world will gain in the end. It is only a question of time, and if the leaders of industry, both masters and men, would only recognise this fundamental truth how much faster progress would be.

It must not be imagined, however, that every invention can or, from the commercial point of view, should be introduced into an industry the moment it is made. Quite apart from the time necessarily spent in developing and perfecting the invention, for which purpose many industries have now instituted research departments of incalculable value, it is sometimes found that the occasion is inappropriate or that the time is not ripe for the change involved. The introduction of a new invention or of a new design may involve many complicated questions of policy or finance, because the change may have to be accompanied by heavy sacrifice in other directions, possibly affecting other industries or the public at large. There may have to be heavy scrapping of spare parts, tools and plant. There may also be considerable loss to the customers of the industry through depreciation of the products of the industry already in use, for nothing depreciates a firm's production more rapidly than the introduction of a new and superior model. Manufacturers have therefore, on some occasions, to collect and husband their inventions and improvements after testing their merits and keep them in reserve for a more opportune occasion. The opportunity may occur very suddenly. It may arise through a sudden whimsical change in fashion which no one can explain, or from some other cause which it has been impossible to anticipate, and if a manufacturer has no policy of improvement all worked out and ready to apply he is faced with the awkward alternative of falling behind the times by making no change at all, or of risking his market by adopting some new model which he has not had sufficient time to test thoroughly. The former policy is almost always disastrous and the latter is often worse. Numerous illustrations of both these courses and their results could be cited from any industry. There inevitably comes to every industry a time when radical change is demanded, and the firm which is best prepared for the change reaps the reward of its foresight.

Industry when viewed in its international aspect determines the lives

of nations. The nation which organises its industry most efficiently, which hampers it least and stimulates it most by legislation, or absence of legislation, and by its scientific foresight, is the nation which will prosper most. Since invention is the heart of industry, the enquirer naturally asks: Is this country doing its best to stimulate invention as a means to foster industry? Are the leaders of industry fully alive to the position which invention plays in industrial progress? Have our legislators ever paused to think that their function is only called for because of the progress which has been made by scientific invention, and that without such progress they would be unnecessary; also that in the past legislation has done much to retard progress? A study of the fundamental scientific causes of progress would form a useful addition to the education of legislators.

Invention as a Link between Exact Sciences.

It is sometimes stated that the Physics of to-day become the Engineering of to-morrow. This is a natural development, since the engineer is more concerned than the physicist with the practical application of physical discoveries. But the converse is frequently true, for many physical discoveries and inventions arise in difficulties encountered by the engineer. The science of practical hydrodynamics is a case in point. The mathematical science of hydrodynamics has been of little service to the engineer in the practical problems of the propulsion of ships, in the complex phenomena of vortex motion associated with the flow of water and steam through turbines, or in problems of aerodynamics, with the result that the engineer has had to develop an empirical science of hydrodynamics to supply his immediate needs. A huge mass of experimental results in screw propulsion, in aerodynamics and in hydraulics has thus been accumulated and is now awaiting some discovery or discoveries in mathematics or physics to correlate it all. If vortices could only be dealt with like potatoes or any other form of merchandise, each a complicated physical system in itself but capable of being considered as a unit differing only in mass or in its energy contents, a forward step might be made. The Lanchester-Prandtl theory of lift and drift of aeroplanes is a first step in a particular case of the general problem. Such a discovery, when made, will be bound to lead to further advances and improvements on the engineering side of the subject.

Most discoveries in Physics arise from some experimental fact discovered more or less accidentally. The discovery of Röntgen rays was accidental, and the enormous strides which have been made in our knowledge of the atom by J. J. Thomson, Rutherford, Bragg, Born and many other physicists during the last thirty years have resulted from Röntgen's discovery combined with another great discovery in pure thermodynamics, Planck's Quantum Theory, which also arose from an accidental discovery made in the course of experiment. The Reichsanstalt in Berlin had published a family of curves representing the distribution of energy in the spectrum of a hot black body. Professor Wien by trial and error obtained an equation to the family, and the form of this equation was suggestive. Planck in trying to develop this equation from the laws of thermodynamics found that he could only do so by assuming that energy is not indefinitely divisible, and he coined the term 'Quantum' to represent the fundamental

unit. These two discoveries of Röntgen and Planck form the starting-point of that most important branch of modern Physics which has increased our knowledge of the constitution of matter, a science which is just beginning to find its field of application in engineering practice, as in the thermionic valve and the modern power transformers on the same lines. From these and other applications great advances are still to be expected.

In reviewing the discoveries in Physics which have had most effect in developing new industries and thus calling forth new inventions, one is struck by the great results in this respect which have arisen from application of the Second Law of Thermodynamics, first stated by Carnot in 1824. Carnot described his ideal heat engine and showed that the efficiency of this engine is independent of the working substance used. Looking back upon the history of the science of thermodynamics of the last century it is unfortunate that no one seems to have employed this statement of Carnot's as a general text, and developed it to find what information could be derived from it by using different working substances and mixtures in order to discover something about all the substances used. Had anyone done so, progress might have been greatly accelerated. James Thomson was the first to use this Second Law to determine the lowering of the freezing-point of water due to pressure. His brother, Lord Kelvin, followed with the application to the change from liquid to vapour. Helmholtz used the voltaic cell as the working substance and determined the temperature co-efficient of its electro-motive force. Then followed at long intervals the application to chemical changes which have resulted in the modern science of thermodynamic chemistry with which the names of Helmholtz, Ostwald, Nernst, Van 't Hoff and Gibbs are so closely associated, and upon which the modern industry of chemical engineering is based. It is a wonderful development to be able to prophesy that under certain conditions a certain chemical reaction will take place, say, that the nitrogen and oxygen of the air will combine at certain temperatures and pressures in a definite proportion, and that the resultant oxide can be recovered and converted to nitrate and used as fertiliser to replace the imported article at an economic price.

The applications of thermodynamic chemistry to explosives enable us to calculate the maximum pressure to be obtained by detonating an explosive, or to calculate the temperatures and pressures throughout the explosion of cordite in a gun from the chemical constituents of the cordite. This possibility has gone far to raise internal ballistics from an empirical science to a branch of Natural Philosophy.

The advances which have taken place in the commercial development of chemical processes based upon this important new science of thermochemistry, although already considerable, are only in their infancy, but the men with the experience gained in practical development are very few; and as the experiments are generally very lengthy and expensive, the development of the industry is necessarily slow. The resultant saving to the country, however, will far outweigh the cost.

Invention forms the natural link between Physics, Chemistry and Engineering, and every advance in one or other of these produces a reflex action on the other. For instance, a discovery in physics which increases accuracy of measurement by providing an indicator more sensitive than

any previously known is soon embodied in an engineering instrument carefully designed and manufactured for sale at a price which makes it available to every physicist for use in further research. Thus modern research in physics and chemistry is carried out with accurate apparatus which would be available only at a prohibitive price if it had been made for the particular research alone. The assemblage of apparatus used in a modern research is sometimes like an engineering installation, and is in marked contrast with the cruder, home-made apparatus, designed *ad hoc*, which was common when some of us were students.

The closer the intercourse between the physicist, the chemist and the engineer the greater will be the fertility in invention and the faster the economic progress. The physicist working continually in a laboratory where everything is specially designed to facilitate accuracy of measurement and to eliminate disturbance, is apt to forget how artificial his working conditions really are, and that before any of his beautiful experiments can have a practical application in industry a great deal of invention is required. As an example of successful invention involving an accurate measurement to be made under practical conditions unsuitable to accuracy, I may cite the Barr & Stroud Range-finder, which was invented by two young professors in this University in the days when it was the Yorkshire College. The problem consisted in measuring with great accuracy, say to a second of arc, the small angle subtended at a distant target by a short fixed base placed at the observer. At the time when this invention was made, some forty years ago, the only scientist who normally measured angles to seconds of arc was the astronomer with his large telescopes mounted on great concrete foundations, with graduated circles from three to six feet diameter and microscopes to read the scales. It seemed therefore impossible to contemplate the measurement of angles with anything like equal accuracy on board a rolling ship and with no expert operator. Yet the two inventors, seeing an advertisement in the pages of *Engineering* announcing competitive trials of range-finders to be held by the War Office, took this seemingly impossible task in hand. There was little time to spare. The first instrument was designed in outline in a week and much of the subsequent success is attributable to the sound physical principles underlying this design and to the very ingenious design of all the constructional details, due to the happy combination of an engineer and a physicist both of whom were men of imagination with a flair for invention. Their range-finder was constructed in the University buildings and, to indicate the amount of time that was available, the final adjustment of the instrument was made on a star from the railway platform at Rugby on the way to the trials at Aldershot.

During the trials the instrument worked well at first, but after the sun came out it commenced to read 'as thousands of yards ranges which were palpably a few hundred' and the inventors discovered that their beautiful angle measurer was also a thermometer and a sunshine recorder combined. They were not surprised to have it rejected, and they might actually have abandoned it entirely if they had not been asked by the Admiralty some time later to submit an instrument for naval use. Then followed ten years of most patient struggle against physical and engineering difficulties, not to mention financial difficulties, for the inventors acted as their own

promoters and the financial side of the business must have taxed their resources to the utmost. But at last they succeeded and their range-finder is now the standard instrument in our Army and Navy and in other countries as well, and has been the foundation of one of our best firms of scientific instrument makers in the country. As student or as assistant I had the honour to serve under both Professor Barr and Professor Stroud, both of them great teachers, versatile inventors and most lovable men, and I am happy to be able to pay this small tribute to them and to their great achievement.

It is unfortunate for Leeds that the transference of Professor Barr to Glasgow in the early stages of this invention should have deprived Leeds of a new industry, and also robbed her later of Professor Stroud as well. Leeds also seems to have been unlucky in regard to at least one other inventor, for Sir Charles Parsons started his life's work in Messrs. Kitson's in Leeds and developed while there his epicycloidal rotary engine, the precursor of the steam turbine which has done so much for British industry in general and for the mercantile marine and navies of the world. I feel sure, however, that Leeds will join with this Association, and with this section in particular, in rejoicing that Sir Charles's great work has recently earned for him, as he so rightly deserves, the highest honour that this country can confer on a scientist, the Order of Merit.

I feel sure that the early history of Sir Charles Parsons' work on the rotary engine and on the steam turbine would form a valuable addition to the scientific history of invention, but it has never been written and is passed over in a few lines in the introduction to Mr. Richardson's excellent treatise on the Parsons' Turbine. From the little that is written, however, it is easy to see that Sir Charles's task was no easy one.

The Difficulties of Invention and their Remedy.

I wish it to be understood that where I have used the word 'invention' I am dealing with the great inventions, and not with the thousand and one minor and comparatively unimportant, though useful, inventions which flood the Patent Office every year. The latter are generally simple affairs, a minor improvement in a known mechanism or a new way of performing an old simple function. I do not wish to belittle these minor inventions in any way. They serve their purpose in our everyday lives, and all are traceable more or less directly to some major invention of the past, but the distinction which I wish to draw is that in very few cases is their manufacture or development a matter of difficulty. I am therefore dealing solely with the big inventions and their development, and it is to the question of the obstacles that are too often encountered in their development that I wish to draw particular attention. This question of difficulty is as old as the history of invention itself, and many of the obstacles have required new discovery or fresh invention to surmount them. I wish now to examine the question of how to eliminate or at least minimise these difficulties that obstruct the inventor and so retard the march of progress.

The first way that suggests itself to me is by means of education. Our educational policy in schools on the scientific side deals with physical laws as facts, and the teacher generally deals only with phenomena with

which he can afford to be dogmatic and ignores the enormously greater range of phenomena about which science knows little or nothing. This system inevitably breeds in the student and in the general public the impression that nature acts according to certain definite laws and that there is nothing about these laws which is not known to science. In actual fact the more the scientist knows about these laws the more he is impressed with his ignorance and the failure of science to fathom the complexity of nature. Much of the misunderstanding of invention and its difficulties is due to this method of teaching and will endure so long as that method is maintained. If it were possible to teach physical and chemical science historically much could be done to counteract this injurious effect.

The experimental laboratory tends to modify the dogmatic teaching of the schools because the student there finds out for himself how exceedingly difficult it is to prove experimentally some of the simplest of the physical facts which he learned in the lecture room, and he thus gains a first-hand knowledge of the order of accuracy of physical measurements and of the difficulty in attaining it. Science taught historically would be infinitely more interesting and instructive, but time is the great obstacle. In a recent leader in the *Times* the teaching of the history of science was advocated as a subject for general culture, and comment was also made on similar recommendations emanating from an American writer. Such a study would introduce a better understanding of the science of invention among those who have not given particular attention to it, and the inventor might come to be regarded as a necessary and valuable cog in the wheel of industrial progress and not, as he is too often regarded, as a freak. After all, the inventor is simply trying to make things simpler and easier and safer for his fellow-men, and he is succeeding beyond belief. Surely that object is worthy of recognition and encouragement.

A second possible remedy to encourage invention and minimise its difficulties is by means of legislation. I hesitate to enlarge on this point because the question of patents is a controversial one among scientists, and between inventors and the outside public, but it seems to me anomalous that a man who makes an epoch-making invention which is going to revolutionise an industry and add millions to the wealth of the nation receives exactly the same degree of protection for his invention as the man who invents a new kind of shirt button. In the first case the invention will take years to develop and may cost thousands of pounds in the process, and by the time it reaches the productive stage the patent may have expired. In the case of the shirt button, a term which I use figuratively, there are no difficulties to overcome, practically no expense, no loss of time and a clear sixteen years' trade monopoly. I know that a patent is granted only for a new method of manufacture which has to be described in the patent specification so that any one skilled in the art may put it into practice at once. In simple inventions which form the subjects of the great majority of patents this is actually the case, but there are undoubtedly cases where what appears to the inventor to be a practical scheme and was honestly described by him as such, proves subsequently to be difficult to put into effect on account of technical diffi-

culties which he had not foreseen, and the remedy for which may not be patentable. Such obstacles and their remedy cannot be recorded in the patent because they have not been encountered when the specification is written. If it be argued that the inventor should not apply for a patent until the practical application of the invention has been achieved, then the inventor argues in reply that by delaying his application he is incurring the risk of having someone else forestall him, by fair means or foul, and so lose his trade monopoly. Under our present system a period of nine months is allowed between filing the provisional and complete specifications, which period, while ample in the case of most inventions, is inadequate for full investigation of the really great inventions, and it is to this difference between major and minor inventions that I wish to draw attention.

In America it is possible for an applicant for a patent, by filing periodical amendments of his specification, to keep the application pending in the Patent Office for a number of years, during which he can be developing the invention and adding to the specification any further explanations which may be called for in the light of the experience gained. Then when the patent is eventually issued it runs for seventeen years from the date of issue, whereas a British patent dates from the date of application. In addition to this, an American patentee, on any question of priority of invention, is allowed to produce any evidence that may be available to show conception of the invention up to not more than two years anterior to the date of his original application. In this way an American inventor can spend several useful years perfecting his invention before his patent is granted, while the British inventor has often to watch the most useful years of his patent being eaten up in unproductive development. I admit that the American system has drawbacks from the point of view of an industry, but it has certain undoubted advantages, and I suggest that our system does not meet the needs of great inventions, between which and the ordinary minor inventions there ought in my opinion to be some discrimination. Merely as a suggestion, I see a possible solution in an extension of our present system of granting Patents of Addition, that is a patent for an improvement on a prior patented invention, the Patent of Addition being granted during the lifetime of the original patent and running coterminously. If a Patent of Addition could be granted to an inventor in approved cases on production of evidence of genuine difficulties encountered and successfully overcome, these difficulties and their remedy to be fully described in the patent for the guidance of the industry, and if this Patent of Addition could be made valid for a definite term of years, one of the main fears of a patentee would be overcome.

It will be noticed that in this last suggestion I have stipulated that the specification of a Patent of Addition such as I suggest should contain not only a description of the finished invention but of all the difficulties encountered in its production and the steps taken to surmount them. In fact, it is mainly for this reason that I make the suggestion at all. I am trying to devise a means to prevent future inventors and industry from being handicapped in a way that has been all too common in the past. I have already touched on what must be the large volume of valuable scientific information that has been lost through lack of records of past

difficulties. Patent specifications are in many cases the sole record of inventions, yet in the cases of the type I have mentioned they tell us nothing of the difficulties, simply because the specification is written before the difficulties are encountered. I therefore suggest that if any additional protection be given to a patentee in virtue of work done in converting his invention into a practical mechanism in face of unsuspected obstacles, the grant should be absolutely conditional on his placing on public record for the guidance of others a complete history of his efforts so that no one may have to contend with the same troubles again.

I have one more suggestion to offer in closing, a suggestion which touches this Association and kindred bodies more intimately. On this question of assisting future inventors by increasing the store of knowledge at their disposal, I see a possible sphere of usefulness for this Association and kindred institutions by encouraging the great inventors of to-day to place on record and publish through the medium of the Association or institution an account, even a brief one, of the main historical features of their inventions. If considerations of patents or of personal diffidence make it undesirable to publish these records at the time they are written, that need not impede the scheme, as publication could be made subsequently at a more convenient time or, say, after the inventor's death. The main thing is to have some authentic record from the inventor or discoverer himself recording the origin, growth and development of his idea, the difficulties that beset him and the manner in which they were overcome. Nor do I think we should stop there. In my opinion too much attention has been paid in the past to success and too little to honest failure. It is one of our human frailties to look with something of contempt on the man who has failed to reach his goal, but this is not the attitude of the great minds, nor should it be the attitude of modern science. On one occasion Lord Kelvin was shown a report by a professor on a research carried out by a research scholar, in which the professor had made some rather contemptuous remarks on the results attained because these results were mainly negative. Kelvin was highly indignant. All he looked to was the fact that the young scholar had done his best on a subject which merited investigation and in face of undoubted difficulties, and it amazed him that any scientist should speak slightly of the results, simply because they were negative, when the real thing of value was the earnest and diligent search after truth.

If therefore my suggestion be adopted by this Association, would it not be in the best interests of science to remember the failures as well as the successes, and to encourage all serious workers in important fields of research to furnish in the common cause a record of their work, even when their aim has not been achieved, giving a faithful account of all the difficulties and all the efforts made to surmount them? Who knows but that many of the so-called failures of yesterday may only be waiting for other hands to-day to carry them on to a greater success than the world has yet known? Left to themselves they will lie in oblivion, yet, for all we know, two of them may fit together and provide the answer to one more of the riddles of the universe.

Knowledge forms the working tools of Science, and my proposal is in no way aimed at giving the scientific workers of to-morrow an easy task.

They will probably have a far more difficult task than ours, but I do not think it fair to condemn them to spend part of their time in a preliminary and possibly fruitless search for tools which we have forged and hidden.

‘As one lamp lights another, nor grows less,’ Science of to-day will partly fail in its clear duty if it fails to pass on to to-morrow any of the knowledge which it has been privileged to acquire, or if it forgets that it is for to-morrow, rather than to-day, to assess the true value of to-day’s success and failure.

SECTION H.—ANTHROPOLOGY.

THE ENGLISHMAN OF THE FUTURE.

ADDRESS BY

PROF. F. G. PARSONS, F.R.C.S., F.S.A.,

PRESIDENT OF THE SECTION.

You will believe me when I tell you that, after hearing the honour which you had done me in making me the president of your section, I thought long and anxiously upon the subject which I should choose for my presidential address, and upon how best I might hope to gain and to hold the interest of a very varied audience, while contributing at the same time my slender share to the advancement of our knowledge.

It was quite clear to me that I must choose the physical side of Anthropology, since on that side lay most of my experience and all my training. Indeed, on thinking the matter over, I began to see that, granting my claim to be an authority at all, I could only hope to be one upon the various races which have helped to make the modern Englishman. And thus my choice slowly narrowed itself until I almost feared that I could do nothing more than repeat the time-honoured though somewhat threadbare process of weighing our ancestors in the balance and in many ways finding them wanting; for, though I should greatly like to have dealt with some local subject, in well-deserved honour to the place in which we are meeting, my want of first-hand knowledge stood in the way, and I found that I could do little or nothing which could not be better done by the local antiquaries and ethnologists.

As I thought over the matter, however, it was borne in upon me, little by little, that some of the characteristics of the Englishman of to-day do not seem to be hereditary at all, and that in some things we, in our development, are not following any Mendelian laws; nor are we harking back to Long Barrow, Bronze Age, Celtic or Saxon types, but that gradually we are building up a new kind of man, differing in certain ways from all of these.

And yet, if I choose for the title of my address 'The Englishman of the Future,' you must not expect me to come before you as a prophet, foretelling that which shall surely come to pass, but rather as a watchman on the wall, who, thinking that he sees dim signs of things stirring, would report them to you and talk over with you what they foreshadow, if nothing happens to stop them meanwhile.

Perhaps, however, it will be well for me if I drop my metaphors before they get me into trouble, and take up my story, which I will make as simple and straightforward as I may.

I must remind you that, during the last fifty years—long before Sir William Arbuthnot Lane and the *Daily Mail* began their health campaign—there has been a steady and rational interest in Hygiene, particularly in

relation to the care of the young. It has been said, and I think truly, that this awakening took place in the old Crimean days, when our loss of men through disease, due to want of hygienic knowledge, was so appalling. I call this interest rational because teachings were no longer accepted as dogmas, but were tried, and their effect carefully watched. In other words, the upper and middle classes were beginning to observe and to think for themselves, with the result that one outstanding belief after another went by the board, and children of succeeding generations were brought up and trained a little differently and, as I think the result shows, a little more wisely than were those of the generation which went before.

It may be objected that this study of child welfare has been going on throughout the ages, and is by no means limited to the last half-century or a little more; but the point which I wish to make is that rational knowledge, based upon experiment and observation, could only have spread after medical men themselves began to learn scientific facts and to teach them to those who were able and willing to understand them.

It is in this way that, each year, the younger generation is brought up a little more sanely than its forerunner; and each year, too, the healthier influences push their way a little lower into the social scale. Now we have reached a stage in which the poorest child of the slums may be, and often is, watched over by the child welfare and almoners' departments of our great hospitals long before it is born, and, if its parents be not too stupid, may, throughout its young life, enjoy very nearly the same healthy surroundings and quite as much skilled medical advice as its richer brethren, save that we cannot yet give it the amount of air it needs in which to sleep healthily, or free it from the results of the ignorant and thoughtless cruelty of uneducated parents. Another generation or two must pass and these things also will cease to be. It is grievous to think that the hardest task of all is to give these poorer children their proper share of pure night air, that deadly terror of our forefathers. So long as slum areas and overcrowding last it is hard to see how this may be done, though the chemists of the future, when they are not too busy with poison gas, may be able to solve this problem too.

Now if all, or even part of this, be true; if for the last half-century children have been better and more sanely cared for, there must surely be something to show for it—something which our eyes may see at a glance, or at least the beginnings of which we may show by contrasted records, indices and tabulations. That there is indeed much to show is clear enough to anyone who has walked the streets of London or of any of our great cities for half a century with open eyes. How seldom nowadays do we see the poor little half-starved bodies, so common thirty years ago, shivering, coatless and bootless, in the depth of the winter; their miserable little limbs maimed by rickets, their ears streaming with matter from middle-ear disease, and their eyelids red with ophthalmia. We know, thank God, that these are fast becoming things of the past; indeed the modern medical student thinks himself lucky if he sees a single case of rickets, about which his text-book has so much to say.

Bad teeth, adenoids, septic tonsils, and glands in the neck, unfortunately, are still common enough, but slowly and surely these are being

conquered, and are bound to be swept away before long; for all this improvement is gathering speed as it rolls on, and each year has rather more to show than that which went before.

I have been visiting lately a number of the London County Council schools in order to see something of the physical characteristics of the rising generation, and I find that, even in the poorest districts, the children are, upon the whole, cheerful and fairly healthy, and a wonderful understanding exists between them and their teachers, who as a class are far above the pedagogues under whom I sat as a boy; while in the secondary schools, particularly in the healthier districts, such as Plumstead and Eltham, the physical beauty and perfect health of the boys and girls contrast very favourably with anything that our most expensive public schools have to show. It is true that I am speaking from the examination of only five thousand out of more than a million London children, and may have to modify my opinion as time goes on; but what I have seen fills me with hope for the future, and never again shall I grudge any taxes which I may be called upon to pay for education, since I realise that, under the cloak of education, London at least is doing its utmost to change a C3 into an A1 population.

And now, feeling sure that a change is coming over our younger generation, let us try to see where it is leading, and whether heredity or environment is taking the greater share in guiding it; though we shall surely be wrong if we allow either of these great influences to leave our minds for a moment. I must be careful not to undertake more than I can carry through in my time; and therefore I will only ask you to let me say a little about the three physical characteristics of stature, coloration and head shape, in order to see whether anything may be learnt from these.

I suppose that no one would dare to say what the average height of the modern Englishman is, because we have no State-controlled and State-aided means of sampling the physical conditions of our population in any way. I can tell you at first hand that the men of our labouring and agricultural classes in the Chilterns average 5 ft. 6 in., and that the mixed classes in a North Kent doctor's practice are 5 ft. 7 in.; but what we do not know is how much the stunted millions in the Midland manufacturing towns, and the mass of unemployed and unemployable humanity in the East of London, will pull this down. I suppose that, taking these into consideration, the average height of the Englishman to-day is not more than 5 ft. 5 in.; though when we speak of the well-nourished classes there is a different tale to tell. I know, for instance, that for the last twenty years my students at St. Thomas's Hospital have averaged 5 ft. 9 in. and in no single year have they ever risen as high as 5 ft. 10 in. or dropped below 5 ft. 9 in.; but, steady though their average at this height has been for twenty years, I am quite sure that they are taller than were my own contemporaries forty years ago, just as those contemporaries, in their turn, were probably taller than the originals of Bob Sawyer's and Ben Allen's fellow-students, who walked the Borough hospitals nearly a century ago.

I think, therefore, that hygiene and better nutrition have done their work so far as stature is concerned, and that the class of Englishmen of

which our London medical students serve as examples have been brought up to, or nearly up to, the limit which their race will reach under the most favourable conditions. It may be indeed that the more intensive health crusade of the last two or three years may cause a new rise in stature which has not yet had time to show itself, but I can see no signs of it as yet. It may be, too, that, though environment may have played its last card, heredity may not have done so, and that if for any reason the individuals with a higher percentage of Nordic traits in their patchwork composition are put in a more favourable position to marry and beget offspring than those with a large number of Alpine and Mediterranean traits, the stature may rise still further.

I feel sure, however, that there is a certain average height beyond which the purest Nordic stock will not rise, and my belief is that this has been reached, or nearly reached, already—so far as the higher classes are concerned.

I am taking no account, of course, of whether there is any advantage to a nation, or to the world at large, in its citizens reaching a very high average stature. Personally I doubt whether, in these modern days of machinery, the losses do not outweigh the gains; for great mental ability seldom accompanies great bodily size, nor as a rule are very big and muscular men such good lives, from a medical point of view, as their more slimly built and wiry fellows. It seems that, while we do well to notice and record the increasing size of our upper and middle class men, we have no great reason to be proud of it. Be this as it may, there can be little doubt that, as all classes come to take an equal share in the benefits of Eugenics, the height of the whole community will increase until 5 ft. 9 in. is the average height of the poorest as well as of the richest; though in those parts of the country in which the Mediterranean element is greatest the stature no doubt will be lowest.

I have given my reasons for believing that we have learnt how to raise our male stature to a point beyond which it will not go, and beyond which it is not well that it should go; but what of the women? About twenty years ago I measured the height of some 150 students of the School of Medicine for Women, and found their average to be 5 ft. 3 in., but after ten years their successors had added a fraction over an inch to their stature; while this year I have measured 150 nurses and massage students at St. Thomas's Hospital whose average height was 5 ft. 4.9 in.

Now these girls belong to the very same class of the community as the male medical students; indeed there are brothers and sisters in the two groups, and the difference with which they have reacted to altered conditions is quite interesting; for, whereas the boys had reached their full average height of 5 ft. 9 in. when first I measured them twenty years ago—and their successors, year by year, have never added anything to, or lost anything from, this height, up to the present—their sisters have gained very nearly 2 inches in the twenty years, and practically have reached the height of the average Englishman, whom we dare not estimate as measuring more than 5 ft. 5 in. There are no signs, moreover, that these healthily nourished girls have reached their maximum, as have the boys.

So far as heredity goes, I know that their Anglo-Saxon forbears

showed quite a small difference between the heights of the two sexes, and it may be that our Englishwomen of the future may reach an average of 5 ft. 6 in. or 5 ft. 7 in. It is unlikely that the two sexes will ever be equal in height, because we know that the stoppage of growth is determined by the union of the caps or epiphyses at the ends of the long bones with the shafts. We know, too, that this closure of the epiphysial lines, as they are called, takes place earlier in women than it does in men. Other things being equal, therefore, woman is handicapped and pays for her well-known earlier maturity by a shortening of the time allotted to growth. To follow this matter up would lead us into a discussion upon hormones and endocrine glands, a discussion which would take us too far afield, although I am fully alive to the importance of the subject.

There is no reason to believe that the union of the epiphysial lines is being delayed in modern Englishwomen, though there is good reason for thinking that, during the period before they unite, growth is taking place more quickly than in former days, since I am told that an increase of height at definite ages is taking place in the children in our L.C.C. schools.

I am not sure that I have made myself quite clear in the matter of heredity and environment. Both surely must be taken into account; and there is always the risk that one observer may try to account for every change he notices by ascribing it to Mendelian influences, while another may see the influence of environment, unchecked by heredity, everywhere. In the present subject of stature we have seen environment, in the shape of wise feeding and a full supply of fresh air, increasing the male height to 5 ft. 9 in. twenty years ago; but at that height the hereditary maximum of the Nordic race seems to have been reached, and since then no improvements in surroundings have been able to increase it. When I say that 5 ft. 9 in. seems the hereditary average maximum of the Nordic race I do not mean that our Saxon forefathers were of that height; indeed I know that they only averaged 5 ft. 6 in. What I mean is that 5 ft. 9 in. seems to be the highest possible score for Nordic peoples.

Now, leaving the question of stature for that of colour, I have two or three points—small perhaps in themselves, but not without interest—to lay before you. One so often hears that the English people are becoming darker that one needs must pay some attention to this point. I was especially struck by a statement made by Miss Fleming, a trained observer, who said that she could find no series of fair children in the slums of Liverpool with which to contrast the dark. Another statement which I came across in the daily Press was made by a medical officer, who said that most of the London poorer children had dark eyes. Before we consider these statements it will be well to agree upon what we are to regard as light and dark, and thus make sure that we are speaking the same language. Rather more than sixty years ago Dr. Beddoe observed and recorded the coloration of a very large number of people in these islands; and since a comparison of his results with those we may gain to-day is our only chance of solving the question of whether we are becoming fairer or darker, it is important to adopt a method of recording colour which is comparable with his. Time will not allow me to explain the details of Beddoe's tabulations, which, for my purposes, are needlessly complicated, but it is easy from his statistics to find the percentage of the

following five shades of hair—Fair, Red, Brown, Dark Brown, and Black—and from these to construct an index by taking the percentage of dark brown and black hair added together.

Beddoe also records the percentage of light, dark, and intermediate eyes; and to me the simplest index seems to be gained by adding half the number of the intermediate eyes to the light and half to the dark, and by then taking the new percentage of dark eyes as the index of eye coloration. This method has the additional advantage of allowing us to use Fleure's records of people in Wales. In most cases it is unwise to use the hair or eyes alone, but to combine the two into a general index of nigrescence by adding the indices of the hair and eyes together and then dividing the sum by two.

An example will make this clear. I take 158 students from St. Thomas's Hospital and find that their hair and eye colours are as follows:—

		%			
HAIR	{ Fair	18	=	11.4	
	{ Red	6	=	3.8	
	{ Brown	87	=	55.0	
	{ Dark	42	=	26.6	
	{ Black	5	=	3.2	
				} 29.8 (Hair Index)	
		158	100.0		
				29.8	
				32.6	
				62.4	÷ 2 = 31.2 (Index of Nigrescence)
				%	
EYES	{ Light	88	+	18.5 = 106.5 = 67.4	
	{ Intermed.	37	<		
	{ Dark	33	+	18.5 = 51.5 = 32.6 (Eye Index)	
		158	158	100.0	

I admit that the personal equation of the observer comes into this, as into all systems, because it is often so difficult to draw the line between brown and dark brown hair; but the difficulty may, to a large extent, be overcome by having an intermediate group between the two, into which all doubtful cases may go, and these may be divided equally between the brown and dark groups before the percentages are worked out.

Let us take this series of students as a sample of the upper middle-class youths in London to-day. Of course they come from all over England, but so do all Londoners. I have, however, been very careful not to include any traceable foreigners in my list.

Sixty years ago Beddoe observed the coloration of 500 male Londoners of the upper classes, and, according to my system, their Hair Index was 40.5, Eye Index 31.2; total index, 35.8.

UPPER-CLASS LONDONERS' COMPARISON.				
Date.	Number.	Hair.	Eyes.	Total.
1860-70	500	40.5	31.2	35.8
1920-27	158	29.8	32.6	31.2

This comparison is given more as an example of method than as an adequate sample of the millions of educated people in London; indeed the whole question of coloration opens up so many points of discussion, and needs such large numbers to reach any definite conclusions, that I must be content, at this stage, simply to give some massed results in trying to solve the question whether Londoners, who practically are Southern English People, have grown darker or fairer during the last sixty years. The following table gives the material which I have:—

ADULT MALES.			
	Hair Index.	Eye Index.	Nigrescence Index.
1860	39.7 (2,400)	35.7 (2,400)	37.7 (2,400)
1927	27.4 (1,485)	33.2 (1,485)	30.3 (1,485)
ADULT FEMALES.			
1860	42.7 (2,813)	40.7 (2,813)	41.7 (2,813)
1927	23.9 (1,487)	35.3 (411)	29.6 (949)
BOYS (8 TO 16 YEARS OLD).			
1927	8.7 (2,565)	33.1 (2,565)	20.9 (2,565)
GIRLS (8 TO 16 YEARS OLD).			
1927	11.0 (1,922)	34.3 (1,922)	22.6 (1,922)

On looking at this table one cannot fail to be struck by the increase in fairness, particularly in the hair; but I do not wish to press it too far, because there are so many possible sources of error. Not only is there the possibility that Beddoe and I had a different border-line between brown and dark brown hair, but other things, such as the modern habit of wearing the hair short, the habit of more frequently washing the head, and the disuse to a considerable extent of pomatum and grease, all give an appearance of fairness which was wanting sixty years ago. In the eye records I place more faith, for both Beddoe and I used an intermediate group between the light and dark eyes, a group which I have divided in both sets of records equally between the light and the dark. The drop in the darkness here is not serious, but I think that it is large enough to be significant.

The children's records at first seem irrelevant, since I have nothing of sixty years ago with which to compare them. Their use is to supplement the present-day eye colours of the adults, especially those of the women, which are very scanty. It will be noticed that in children of eight to sixteen the eye colours have become permanent, though the hair has not, and thus their evidence is valuable. These records, which run into several thousands, do not give us any reason to think that the Londoner is becoming darker, but do give us reason, though it may need discounting, to believe that he is growing fairer under changing conditions.

This question of coloration statistics may be of special as well as of general interest, for a neurologist lately assured me that quite 50 per cent. of his patients had dark eyes, and asked me whether this were above or below the general average of the population. The relation of other diseases to coloration also has been worked at by Dr. Shrubsall and others, but can be valuable only when the normal percentage is known.

The last point to which I wish to draw your attention is head shape. As you know, the anthropologist usually thinks of skulls in terms of their length and breadth, and certainly he has gained a great deal of useful information in the past from this cranial index, his so-called sheet-anchor. Lately, however, he has felt that something more is needed, and specialists in craniology have piled up such a mass of arcs, indices, coefficients, and angles that few are able to criticise their fellow-workers, because few are able to understand what their fellow-workers are doing.

Unfortunately we cannot claim that the results have kept pace with the growing complexity of the methods, and if we are ever to interest the non-specialist, and to induce him to add to our knowledge by using the enormous mass of material which comes in his way, we must devise some system simple enough to be grasped by any educated person and yet more valuable than the mere record of the length and breadth of the head.

The reason why the cranial or the cephalic index is not enough is that it treats the head as if it were a structure of two, instead of three, dimensions. To use a homely simile, it is like giving the length and breadth of a box and then expecting the hearer to grasp what that box is like. We have hundreds of thousands of records of the length and breadth of heads, but very few of their height. Even when the height is recorded we set it down and try to visualise it by comparing it with the length—just as we compare the breadth of the skull with its length.

In other words, we use the length as though it were a constant with which we could compare the variable breadth and height, though we know that the length may be just as variable as either of the other diameters.

I want to submit to you that, if we use all three dimensions—length, breadth, and height—together, a standard will be gained which roughly will represent the size of the skull, and with this each dimension may be compared, and a proportional index for each established. The most accurate method, no doubt, is to take the product of the three dimensions and then to extract the cube root and multiply it by three. The result of this is a standard by which the length, breadth, and height of the skull may be divided, and in this way proportional indices obtained which will bear a definite relation to the size of the skull. Unfortunately the process, though soon learned, is tiresome and needs a logarithm table, which is not always to hand.

A much simpler, and for all practical purposes an equally valuable method of gaining proportional indices is to add together the length, breadth, and height of the skull, and then to divide each dimension by the sum thus obtained. This gives a series of indices which are, on an average, .006 lower than those which the cube-root system supplies; but in no case does this alter the relative position of any of the series of British skulls tabulated in the accompanying list. My colleague, Dr. Mulligan, has been kind enough to prepare a second table which shows how nearly the results of the two methods correspond.

Before considering these tables, which I think give a more rational and coherent view of British craniology than could be obtained from the old cranial index, though I am glad enough to use that too, let us take as an example the skull of a Saxon, lately dug up at Bidford-on-Avon.

Its length is 205 mm., its breadth 149 mm., and its vertical height, from the top of the ear passage, 124 mm.

$$L. 205 + B. 149 + H. 124 = 478 \text{ (L. + B. + H. Standard)}$$

$$\begin{array}{ccc} L. & 205 & B. & 149 & H. & 124 \\ \text{Standard} & 478 = \cdot 429 & \text{Standard} & 478 = \cdot 312 & \text{Standard} & 478 = \cdot 259 \end{array}$$

In other words, the length is $\cdot 429$, the breadth $\cdot 312$, and the height $\cdot 259$ of the sum of the three dimensions; and these we may speak of as the proportional length, breadth, and height indices.

Now suppose that we want to contrast this Saxon's cranium with that of a London medical student of to-day, whose head measurements are as follows: L. 202, B. 149, H. 140. We must remember, of course, that we are dealing now with cephalic, not cranial, measurements, and that the soft parts of the scalp have been included; while in the Saxon was included the skull alone.

We must therefore deduct 8 mm. from the length and breadth and 5.5 mm. from the height to allow for these; this reduces the measurements to L. 194, B. 141, H. 134.5. Still another deduction is needed, because the height was measured with an auricular height craniometer, which fits into the centre of the ear-hole, while the Saxon skull was measured from the top of the opening; thus another 6 mm. must be deducted from the height of the modern skull to allow for this. Now the measurements are comparable, and the two skulls give the following results:—

$$\begin{array}{rcl} & L. & B. & H. & \\ \text{Anglo-Saxon} & 205 & + 149 & + 124 & = 478 \text{ mm.} \\ \text{Modern Londoner} & 194 & + 141 & + 128.5 & = 463.5 \text{ mm.} \end{array}$$

It is pretty clear that this particular Saxon had a larger head than the student, and if we want to see where the gain and loss occurred the actual measurements must be reduced to their proper proportions, as follows:—

	Proportional Length Index.	Proportional Breadth Index.	Proportional Height Index.	
Anglo-Saxon . . .	$\cdot 429$	$\cdot 312$	$\cdot 259$	$= 1.000$
Modern Londoner . . .	$\cdot 419$	$\cdot 304$	$\cdot 277$	$= 1.000$
Londoner . . .	$-.10$	$-.8$	$+ .18$	

Now it is seen at a glance that this particular London student has a head which is shorter and narrower, but a great deal higher in proportion to its size, than that of the particular Saxon with which it was compared.

In this instance I have reduced the Londoner's head to a skull in order to compare it with that of the Saxon, but of course it would have been just as easy to have reversed the process and to have clothed the Saxon skull with the necessary allowance for soft parts. This, indeed, is what I propose to do in the table of proportional indices which I may now lay before you, since the living head measurements are more numerous than those made upon skulls. Anyone using this table must please bear in mind that all the skulls have had 8 mm. added to their average length

	1	2	3	4	5	6	7	8
	Length.	Breadth.	Aur. Ht.	Ceph. Ind.	L. + B. + H.	Proportion of L. B. H.		
			B.C. 5000?					
Neolithic (Schuster) ¹	201·7 (53)	146·9 (128)	123·1 (8?)	728	471·7	·428	·311	·261
Neolithic (Parsons) ²	204·0 (20)	148·0 (20)	122·5 (20)	725	474·5	·430	·312	·258
			B.C. 2000?					
Beaker Folk (Morant) ¹	192·5 (48)	157·9 (89)	126·6 (7)	820	477·0	·404	·331	·265
Beaker Folk (Parsons) ²	188·0 (16)	156·0 (8)	122·5 (16)	830	466·5	·403	·334	·263
			B.C. 600?					
Celtic Iron Age (Morant) ¹	195·4 (61)	149·4 (102)	No record	764	—	—	—	—
Celtic Iron Age (Wright)	194·0 (23)	144·0 (23)	No record	742	—	—	—	—
			A.D. 500.					
Anglo-Saxons (Morant) ¹	198·6 (58)	149·7 (103)	120·4 (17)	754	468·7	·424	·317	·259
Anglo-Saxons (Parsons)	204·6 (47)	151·2 (48)	121·9 (48)	739	477·7	·428	·317	·255
			14TH AND 15TH CENTURIES.					
Hythe (Parsons) ²	187·0 (324)	151·0 (324)	119·5 (291)	812	457·5	·409	·330	·261
Rothwell (Parsons) ²	194·0 (99)	150·0 (100)	120·0 (100)	773	464·0	·418	·323	·259
			17TH CENTURY (PLAGUE SKULLS).					
Whitechapel (Macdonell) ³	197·1 (137)	148·7 (135)	120·1 (135)	754	465·0	·423	·319	·258
Moorfields (Macdonell) ⁴	197·2 (44)	151·0 (46)	119·3 (46)	765	465·0	·422	·323	·255
Farringdon St. (Hooke) ⁵	196·8 (139)	150·4 (141)	115·5 (76)	764	462·7	·426	·326	·248
			18TH CENTURY.					
Clare Market (Parsons)	196·0 (30)	150·0 (30)	119·5 (30)	765	465·5	·421	·322	·257
			EARLY 19TH CENTURY.					
English Soldiers Millbank (Parsons)	195·2 (44)	147·0 (44)	121·9 (44)	753	464·1	·421	·317	·262
			20TH CENTURY.					
Royal Engineers (Bennington) ⁶	194·9 (118)	151·1 (118)	125·9 (118)	775	471·9	·413	·320	·267
St. Thomas's Patients	193·0 (150)	150·0 (150)	127·8 (73)	777	470·8	·410	·319	·271
British Assocn. ('Biometrika') ⁷	198·1 (?)	155·0 (?)	130·9 (?)	782	484·0	·409	·320	·271
St. Thomas's Students	196·1 (158)	154·0 (158)	130·9 (81)	785	481·0	·408	·320	·272
Oxford Undergrads (Schuster) ³	196·1 (959)	152·8 (959)	130·6 (959)	780	479·5	·409	·319	·272
Brit. Anatomists (Dublin, 1898)	197·7 (27)	156·3 (27)	134·0 (27)	791	488·0	·405	·320	·275
Univ. Coll. Staff (Pearson) ⁷	196·4 (25)	153·5 (25)	135·0 (25)	782	484·9	·405	·317	·278

¹ *Biometrika*, Vol. 18, p. 82. ² *J. R. Anthropol. Inst.* ³ *Biometrika*, Vol. 3, p. 208.⁴ *Biometrika*, Vol. 5, p. 92. ⁵ *Biometrika*, Vol. 18, p. 1. ⁶ *Biometrika*, Vol. 8, p. 131.⁷ *Biometrika*, Vol. 1, p. 204. ⁸ *Biometrika*, Vol. 8, p. 49.

and breadth and 5.5 mm. to their auricular height. All those living heads or skulls, on the other hand, the auricular height of which has been measured by a craniometer or head-spanner which fits into the middle of the ear-holes, have had 6 mm. deducted from that height, because at the Frankfurt agreement it was decided that the auricular height should be taken from the top of the auditory opening.

Columns 1, 2, and 3, therefore, give the length, breadth, and height averages of the heads with the soft parts in position, and the figures in parentheses represent the number of heads upon which the averages are based. Column 4 is the proportion of the breadth to the length, or the cephalic index. Column 5 is the sum of the length, breadth, and auricular height, of which the three succeeding columns are fractions; while columns 6, 7, and 8 show the proportions which the length, breadth, and height bear to the sum of the three in column 5.

The following lists show how little difference there is between an index constructed from the length, breadth, and height of the skull and one constructed from the cube root of the product of the three measurements. Whichever index is used the relative positions of the various groups of skulls remain unchanged; and for this reason I do not think that the extra time and labour needed in working out the product index is repaid in any way.

	HEAD LENGTH.			CRANIAL CAPACITY (from Lee's Formula).
	Sum Index. L	Product Index. L	Differ- ence.	
	$L+B+H$	$\sqrt[3]{L \times B \times H}$		
Neolithic (Schuster)428	.437	.009	c.c. 1,385
Neolithic (Parsons)430	.440	.010	1,399
Beaker Folk (Morant)404	.409	.005	1,445
Beaker Folk (Parsons)403	.409	.006	1,370
Anglo-Saxons (Morant)424	.433	.009	1,366
Anglo-Saxons (Parsons)428	.438	.010	1,420
Hythe409	.416	.007	1,307
Rothwell418	.426	.008	1,340
Whitechapel423	.432	.009	1,348
Moorfields422	.431	.009	1,357
Farringdon Street426	.435	.009	1,318
Clare Market421	.430	.009	1,346
English Soldiers421	.429	.008	1,342
Royal Engineers413	.420	.007	1,403
St. Thomas's Patients410	.416	.006	1,402
British Association409	.416	.007	1,486
St. Thomas's Students408	.413	.005	1,475
Oxford Students409	.415	.006	1,464
British Anatomists405	.410	.005	1,530
University College Staff405	.410	.005	1,510
			Average difference .007	

—	HEAD BREADTH.			HEAD HEIGHT.		
	Sum Index. B	Product Index. B	Differ- ence.	Sum Index. H	Product Index. H	Differ- ence.
	$L+B+H$	$\sqrt[3]{L \times B \times H}$		$L+B+H$	$\sqrt[3]{L \times B \times H}$	
Neolithic (Schuster)	.311	.318	.007	.261	.267	.006
Neolithic (Parsons)	.312	.319	.007	.258	.264	.006
Beaker Folk (Morant)	.331	.336	.005	.265	.269	.004
Beaker Folk (Parsons)	.334	.340	.006	.263	.267	.004
Anglo-Saxons (Morant)	.317	.326	.009	.259	.262	.003
Anglo-Saxons (Parsons)	.317	.324	.007	.255	.261	.006
Hythe .	.330	.336	.006	.261	.266	.005
Rothwell .	.323	.330	.007	.259	.264	.005
Whitechapel	.319	.326	.007	.258	.263	.005
Moorfields .	.323	.330	.007	.255	.261	.006
Farringdon Street	.326	.333	.007	.248	.256	.008
Clare Market	.322	.329	.007	.257	.262	.005
English Soldiers	.317	.323	.006	.262	.267	.005
Royal Engineers	.320	.325	.005	.267	.271	.004
British Asso- ciation	.320	.325	.005	.271	.274	.003
St. Thomas's Patients	.319	.323	.004	.271	.275	.004
St. Thomas's Students	.320	.325	.005	.272	.276	.004
Oxford Students	.319	.323	.004	.272	.276	.004
British Ana- tomists	.320	.324	.004	.275	.278	.003
Univ. Coll. Staff	.317	.320	.003	.278	.282	.004
	Average difference .006			Average difference .005		

It will be noticed that we are fortunate enough to have two independent sets of measurements of the three main stocks which went to the making of the Englishman—the Mediterranean, represented by the Long Barrow or Neolithic Race; the Alpine, represented by the Beaker Folk; and the Nordic, represented by the Anglo-Saxons. One of each of these three sets has been measured by myself, and the other has been measured or collected by Mr. Morant, who published them in *Biometrika*.¹

Now, although neither the authorities of *Biometrika* nor I are unqualified admirers of the other's methods, I firmly believe that we both are trying to find out the truth, according to our lights and limitations; and in this case our results, when reduced, as I have reduced them, to proportional indices, are so nearly alike that, however much we might wish to, neither of us can attack the other with any reasonable chance of success.

If we add the proportional indices of the three stocks together and divide them by three, the result is as follows:—

	Length.	Breadth.	Height.	
Morant . . .	·4185	·3200	·2615	=1·0000
Parsons . . .	·4205	·3210	·2585	=1·0000
Mean . . .	·4195	·3205	·2600	=1·0000

This result, surely, is as close as two people working upon different samples and different numbers of skulls of the same races could be expected to reach; and there is every reason to believe that the mean between the two sets of results is more likely to be nearer the truth than either of them taken separately, and ought roughly to represent what we should be likely to find, in the descendants, if equal numbers of Long Barrow folk, Beaker folk, and Anglo-Saxons were mixed and allowed to interbreed.

Let us compare this with the records of the Northamptonshire people who lived at Rothwell in the fourteenth and fifteenth centuries:—

	Length.	Breadth.	Height.	
Mean of Long Barrow, Beaker, and Saxons . . .	·4195	·3205	·2600	=1·0000
Rothwell	·4180	·3230	·2590	=1·0000
Hythe	·4090	·3300	·2610	=1·0000

This shows that if we evolve, as we have done in the first line, the kind of skull which a mixture of the three main stocks which we know went to the making of the mediæval Englishman would produce, we get a form which, in its proportional length, breadth, and height, is almost identical with that found in the Midlander of the Middle Ages, as shown in the second line.

When, however, the Hythe crania, shown in the third line, are compared with these, we see at once that they must have had a different parentage;

¹ *Biometrika*, vol. 18, p. 82.

and what that parentage is becomes plain when they are placed in company with the Beaker folk.

	Length.	Breadth.	Height.	
Hythe	·4090	·3300	·2610	=1·0000
Mean of Morant and Parsons' Beaker Folk	·4035	·3325	·2640	=1·0000

It seems to me as clear as clear can be that these Hythe people, in the fourteenth and fifteenth centuries, were the result of an incursion and settlement of people from the Continent, of the Alpine Race, who had been slightly, but only slightly, modified by mixture with the Kentish folk.²

In the eighteenth century the Londoners who lived in the neighbourhood of Clare Market had skulls the proportional dimensions of which differed very little from those at Rothwell:—

	Length.	Breadth.	Height.	
Rothwell	·418	·323	·259	=1·000
Clare Market	·421	·322	·257	=1·000

Apparently, however, there was a little more of the Nordic and a little less of the Alpine element about them.

In the seventeenth century three series of plague skulls are available and were described by Macdonell and Hooke. They are remarkable for their low vaults and receding foreheads, and it has been suggested that they show that the modern Londoner has reverted to the Early Iron Age type, though formerly Pearson regarded them as Long Barrow in their characteristics. Unfortunately we know very little of the craniology of the Early Iron Age, and I see that Morant cannot find a single record of what their auricular height was.³ We must therefore let this suggestion stand over until more work has been done upon the head shape of the Iron Age. There is one point, however, which I think should be borne in mind, especially since the Londoners seem to have gone back to a more normal head height in the eighteenth century; it is that during the plague the better class of citizens fled from the city, leaving the dregs of the population behind, and it is in these dregs that receding foreheads and

² Writing in *Biometrika* (vol. 18, p. 22) Miss Hooke says that the Hythe skulls were 'in all probability those of Kentish men.' This I no longer believe, because I examined a number of skulls of the same date from the crypt of a disused church at Dover and found them quite different from those at Hythe. Again, the same writer says that the skulls which I recorded at Hythe were 'selected' from at least double the number. This, if it were true, would necessarily make the Hythe records valueless; but it is absolutely untrue, since I examined all the skulls which were available at the time, and no selection whatever was made. Since then more skulls have been recovered from the stack, but there is no reason to believe that they differ in any way from those which I measured.

³ *Biometrika*, vol. 18, p. 82.

low cranial vaults are most likely to be found. I cannot think that it is wise to use plague skulls as types of seventeenth-century Londoners as a whole.

Now we come to a new and striking development. It will be noticed that, until the eighteenth century, the only skulls which show a proportional auricular height of over $\cdot 260$ are those belonging to the Alpine Race, that is to say the Beaker Folk and the Hythe people. Morant, it is true, quotes Schuster's Long Barrow Folk as having $\cdot 261$, but there were only eight of these available, and twenty more gave me an average of $\cdot 258$.

It is therefore fairly clear that in none of the races which have helped to make the modern Englishman was the height of the head more than $\cdot 260$ of the length, breadth, and height added together, except in the Beaker Folk, where it reached at the highest computation $\cdot 265$.

Bearing this in mind, it is interesting to notice that in the early nineteenth century the proportion of the head height of English soldiers was $\cdot 262$, while in the men of the Royal Engineers, measured by Benington, in the early part of the twentieth century it had risen to $\cdot 267$, and in the patients at St. Thomas's Hospital in the present day it is $\cdot 271$.

These last three examples are of the less well-educated classes, and even in these it is remarkable how the proportional height of the head has risen well above anything which any of our ancestors can show, even were we to claim the Beaker Folk as our main ancestors, which all the evidence tells us would be unjustifiable.

But when we come to measure the educated classes of the community, which have enjoyed a greater share of the modern, improved conditions of environment, the result is still more striking, for we see the members of the British Association with a proportional head height of $\cdot 271$, the St. Thomas's Hospital students with $\cdot 272$, the Oxford undergraduates with $\cdot 272$, a number of British anatomists who met in Dublin in 1898 with $\cdot 275$, and the University College staff with $\cdot 278$.

Perhaps the point will be brought out more clearly if the means of the groups of the proportional head measurements are contrasted. Unfortunately I am unable always to take the number of observations into account, since I have never been able to find out how many members of the British Association were measured, but I find that where I have the numbers it would have made no appreciable difference to the results had I used them.

We may see at the beginning of this list the relative proportions of the three chief cranial measurements of the three stocks which took part in making the mediæval Englishman—the Mediterranean, the Alpine, and the Nordic. At Rothwell we have, in the fourteenth century, the result of the fusion of these three. In the seventeenth century, according to my reading, are the dregs of the populace, with their low cranial vaults, left behind to die of plague in London. At Clare Market again in the eighteenth century is the low-vaulted, slum population of a great town; while in later years the height of the skull vaults has increased proportionally with improved conditions of life, until in the richer and more intellectual classes, which have enjoyed more of these improved surroundings, the head height has increased enormously.

	Proportion to the sum of the three.			
	Length.	Breadth.	Height.	
Mean of Schuster and Parsons' Neolithic	·429	·311	·260	=1·000
Mean of Morant and Parsons' Beaker Folk	·404	·332	·264	=1·000
Mean of Morant and Parsons' Anglo-Saxons	·426	·317	·257	=1·000
Fourteenth and Fifteenth Century (Rothwell)	·418	·323	·259	=1·000
Mean of Whitechapel, Moorfields and Far- ringdon Street, seventeenth-century Plague Skulls	·424	·323	·253	=1·000
Clare Market, eighteenth century	·421	·322	·257	=1·000
English Soldiers (Millbank), eighteenth century	·421	·317	·262	=1·000
Poorly educated classes, twentieth century (Mean of Benington and Parsons)	·412	·320	·268	=1·000
Highly educated classes, twentieth century (Mean of Pearson, Schuster, and Parsons)	·407	·319	·274	=1·000

At one time I looked upon this change as the result of the immigration of people of Alpine and Slavic descent from the Continent in the last century, but I think so no longer, since I have examined a series of modern, short-headed skulls from the Continent and find that these, like our own Beaker Folk, always have an average proportional breadth of more than ·330, while our modern English people show no sign of increasing their proportional breadth and greatly exceed the Continental proportional height.

I can see no signs of heredity or harking back to any known ancestry in the change which is coming over the English head, but only signs of reaction to environment. Is it not reasonable to think that, as the improved conditions of life are gradually shared by all classes, this change in the head shape will gradually become more general until the Englishman of the future is a man with a very differently proportioned head from that of any of his ancestors? Please do not think that I wish to decry the old cranial index; it has helped us much in the past, it will help us much in the future. All that I would say is that unless we take the proportional height into account we shall miss a great deal that we ought to know.

To sum up this, which I fear is a too lengthy communication, I am left with the belief that the Englishman of the future is, if present conditions persist, making for an average height of 5 ft. 9 in., and the women for one of 5 ft. 6 in. or 5 ft. 7 in.

That our people have reached, and are stationary at, a stage in which some 66 per cent. have light eyes and some 34 per cent. dark.

That there are no signs whatever that the hair colour has darkened during the last sixty years, though there are signs, which perhaps need discounting, that the hair is lighter than it was sixty years ago.

That the head shape is showing unmistakable signs of an increase of its proportional height, with a decrease of its proportional length, and that this increase of proportional height is greater than has been found in any of the stocks from which the modern Englishman is derived. It therefore cannot be looked upon as a harking back to any ancestral form, but must be regarded as an evolutionary process, in harmony with the

greatly changed conditions of life which have come about during the last century.

After all this suggestion, which a study of the head height presses upon us, is one which many have held for a long time. If we accept it I fear that many of the sentimental attractions of British Anthropology will be lessened, since there will be greater difficulty in determining whether the modern Englishman has more Saxon, Neolithic, Alpine, or Iron Age blood in his veins; and we must realise that he is becoming an individual who could not be formed by any possible combination of these stocks without the aid of external influences. Heredity alone, therefore, will not account for the Englishman of the future.

.

SECTION I.—PHYSIOLOGY.

THE DEVELOPMENT OF HUMAN
PHYSIOLOGY.

ADDRESS BY

C. G. DOUGLAS, C.M.G., M.C., D.M., F.R.S.,

PRESIDENT OF THE SECTION.

IN physiology our task is to study the nature of the phenomena which characterise normal life, as shown in the individual organism. At the outset it would perhaps seem presumption on our part to turn our attention to what we must admit to be the most complicated and highly developed organism, namely, man, before we have been able to elucidate at least the main features of the life-process of more lowly forms; should we not do better to argue from the simple to the complex? Yet I suppose that man has always been curious about himself, his functions and existence, and nothing is likely in the future to lessen this curiosity. It is no matter for wonder, therefore, that the early history of physiology is bound up with the development of medicine, and that those whose daily life necessarily brought them into continual association with health and disease, and with life and death, should be among the first to turn their attention to the investigation of the nature of living processes.

It is not, however, of the early days of physiology that I propose to speak. The progress made in the biological and physical branches of natural science has been amazingly rapid in recent years, and I want to try to reach some estimate as to the value of human physiology in the development of modern physiological thought.

In the last fifty years we have seen the wide extension of what I may term the analytical method of physiological investigation, the attempt to differentiate the various components in the complex system which we call life, and to study in detail each of these components in turn and to render clear the phenomena peculiar to each. The organism is in this method treated as a series of systems—we speak, for instance, of the nervous system, the circulatory, the respiratory and the excretory systems—which, though no doubt but parts of a whole, are yet capable of being treated within limits as independent. In pursuing this method we have a perfectly definite aim, for we are trying to establish elementary facts about the different parts of the body without some knowledge of which we feel, and feel rightly, that a general conception of the whole is impossible. No one can deny that we have acquired in this way a mass of information which is essential to the whole study of physiology, nor is there any reason to suppose that the future will witness any diminution either in number or importance of the contributions thus made to knowledge.

The bulk of this information has been attained by the deliberate and careful investigation of animals by experimental methods, and as I am going to plead the cause of human physiology may I say at once, lest you should misconceive my purpose, that I do not believe that progress in physiology and in medical science to the lasting benefit of mankind is possible without employing such methods. But, while acknowledging the great debt which we already owe to these investigations, and my firm conviction that their further prosecution will be fully justified in the future, I have to face the question whether the method has not in reality some limitations.

We are bound, I think, to admit frankly that direct observation by methods involving operative procedure on the anæsthetized animal cannot by itself give us the full answer that we require. I have defined physiology as the study of the nature of the phenomena which characterize normal life, and normal life involves constantly varying activity of all the different organs of the body. Under the influence of an anæsthetic our subject is no longer normal, and we have perforce deliberately to close our eyes to that fundamental aspect of life—ceaselessly varying natural activity. We are forced to adopt methods of investigation which are essentially highly artificial; the stimuli which we employ are usually coarse, and the changes to which we subject the organs gross, compared with the delicate alterations to which these same organs respond in natural life. But even if we admit this, are we to condemn the method? Certainly not, in my opinion, provided always that we recognize that there is this risk of abnormality and artificiality, and honestly ask ourselves the question—what is the precise significance of our results in relation to normal life? how far do our observations really help us to understand the phenomena associated with the natural existence of the organism? We may be accumulating facts; can we translate them?

If we are to understand life we must ultimately adopt methods of investigation which do not interfere with the normality of the organism or its power of self-maintenance; and clearly, so long as we keep this aim before us, we are perfectly justified in making our observations on any animal the study of which we think will help to solve our problem. The conditions will be satisfied so long as our experimental treatment, whether that involves operative procedure or not, does not materially prejudice the delicate regulation of bodily functions which is so evident in the normal intact animal. Pavlov's classical researches on the secretion of the digestive juices were principally made on dogs which, though previously subjected to operation, were yet capable of exhibiting the normal functions and activities of life, and the requisite conditions were therefore just as effectively fulfilled as in, for example, the fundamental observations made by Rubner on nutrition and energy liberation when absolutely intact animals served as subjects. And yet, in spite of such examples, the point which I want to emphasize is that in the study of normal physiology man is in many instances a far more advantageous subject for investigation than are the lower animals.

It may be urged that, so far as concerns the natural variations in activity of everyday life, we may study the lower animals just as profitably as man. But can we guarantee that any animal, even though highly

trained, will provide the particular state of activity that we may require at the moment? Man at least will conform with our requirements, and will maintain at request either rest or any degree or type of activity which we may desire. What is more, he, though himself the subject of investigation, can help us to make our observations, and very often intelligent co-operation on the part of the subject may render easy experimental procedure which would otherwise be impossible. We gain, too, the advantage of learning the subjective impressions of the person on whom we are making our experiments. Everyone will admit the importance of these impressions when studying the physiology of the sense organs, but may they not be of value, too, in the investigation of other functions? Indeed they may help us not infrequently to gauge the normality or abnormality of the conditions under which we are working. The point of view of the mere spectator is, after all, an impersonal one, and if it can be amplified and perhaps corrected by reference to the feelings of the subject so much the better. The investigation of life is too difficult a task to allow us lightly to discard any method which may help us, and if we confine our attention to the lower animals we do limit ourselves to objective experience and renounce the possibility of assistance from subjective impressions.

Can my assertion that there is a definite advantage in doing experiments on man be justified by the information that has already been gained from investigations on the human subject? Let me briefly discuss the position.

We know, it is true, not a little about the respiratory exchange of animals, but we can fairly claim to know very much more about the oxygen consumption, CO_2 output and energy exchange of man. Data have been obtained on man whilst resting, walking, running, pedalling a bicycle, rowing, swimming, traversing the snow on ski or the ice on skates, performing military exercises, hewing coal at the pit face or pursuing other industrial occupations, and doing mental work—a fairly representative collection of man's various activities in his daily life.

Such information is not of mere academic interest; it has not been obtained solely to satisfy our idle curiosity; it is fundamental to physiology. We learn from it how greatly the oxygen requirements and the energy output vary with changes in occupation—we find that the energy output when walking at four miles an hour is five times as great as during rest, and that the trained athlete may for a number of minutes maintain an oxygen consumption not far short of twenty times the resting value—and we begin to realize quantitatively something about the latent possibilities in the respiration, circulation and other bodily functions which must be called upon to adapt themselves from moment to moment to meet such widely varying demands. Observations on the general metabolism and energy exchange in man have played, too, a conspicuous part in the development of our knowledge of the general principles of dietetics and of the science of nutrition both of the individual and of the nation.

Research on the intact, or practically intact subject, naturally demands methods of investigation of very different character from those direct experimental methods which may be employed when full functional

integrity is no longer preserved. The history of the development within recent years of our ideas about respiration has afforded a striking example of the application of such methods. Twenty-two years have elapsed since the publication of Haldane's and Priestley's classical paper on the regulation of the lung ventilation. Up to that time our knowledge about the breathing was surprisingly small: we accepted the fact of the apparent automaticity of the breathing, and recognised that the respiration adjusted itself suitably to changes in bodily activity, but we had no satisfactory explanation to offer; isolated facts were known, but we could not combine them into an intelligible whole. Then suddenly light was thrown on the whole situation by a series of experimental observations on human subjects in full possession of their normal faculties and with their natural powers of response to changes in their immediate environment unimpaired. The reason for the activity of the respiratory centre in the brain was shown to be due in the main to the fact that it was sensitive to the actual concentration of CO_2 in the arterial blood which reached it. A trifling rise in this concentration above the value shown during quiet breathing at once caused hyperpnœa, a trifling fall was at once followed by reduction, if not complete cessation of the breathing. As the determining factor was apparently the concentration of CO_2 in the arterial blood, a concentration set by the composition of the air in the depths of the lungs, it became evident that the activity of the respiratory centre was proportional to the mass of CO_2 produced in the body and carried to the lungs, and this in turn implied that the quantitative correlation of the ventilation of the lungs with the changes of metabolism in the body as a whole was ensured by chemical means. From this work, too, we gained our first real insight into the amazing delicacy of true chemical correlation within the organism.

Since that date innumerable contributions have been made to the physiology of the breathing, and the bulk of these have been made with man as the subject of investigation. We recognize now that the respiratory centre is sensitive not to CO_2 as such but to changes in the hydrogen ion concentration of the blood, that lactic acid accumulation as well as increased CO_2 production must be taken into account when studying the hyperpnœa caused by muscular exertion, and that reduction in the oxygen concentration in the arterial blood and alteration in the temperature of the blood may play contributory parts. Yet in spite of this, the fundamental conception of accurate chemical or physico-chemical co-ordination of function remains unimpaired: so long as the respiratory centre is sensitive to chemical or physical changes which result from alterations in activity of the different organs, the quantity of air breathed must be co-ordinated with the varying metabolism of the body.

And when once we have ascertained the quantitative alterations in the respiratory exchange which correspond with our varying activity during the course of the day, and have grasped the fact that the breathing is automatically adjusted in correspondence with the tissue metabolism, because the cells of the tissues are so intimately linked with the respiratory centre in the brain by the blood stream that the degree of activity of the respiratory centre is actually determined by the events in those organs whose metabolism happens to vary, we are led on logically to a further inquiry. For so delicate an adjustment of the breathing in conformity

with changes in the activity of the tissues would be valueless without an equally delicate co-ordination of the circulation, since on this depends the transport of gases between the tissues and the lungs; nor would this suffice unless the blood were of such a nature as to afford a suitable medium for the carriage of oxygen and CO_2 .

So far as our knowledge of the properties of the blood itself is concerned we can point to a great deal of progress. Naturally enough, the blood of many different animals has been investigated, but it has been found that the dissociation or absorption curves, which express the relationship between the amount of gas held in dissociable combination in the blood and the concentration of that gas to which the blood is exposed, differ in different species, and indeed in different individuals of the same species, and this fact makes it imperative that in physiological work the properties of the blood of the individual under consideration at the time should be investigated. Correct inferences as regards the properties of human blood from which we may deduce the exact part played by the blood in gas transport cannot therefore be drawn from studies of the blood of lower animals, and in consequence we find that more and more attention is being directed to the experimental investigation of the blood of man under widely varying conditions, both in health and in disease.

I suppose that as much attention has been directed by physiologists to the circulatory system as to any other branch of physiology, and yet when we begin to question ourselves about the true functional regulation of the circulation our information still seems to be amazingly hazy and indefinite. Direct observations on the anæsthetized animal with the assistance of recording instruments have established a number of perfectly definite facts. We have some notion of the mechanics of the circulatory system; we have ascertained the general course and distribution of the vaso-motor nerves; we have found that not only the arteries but even the capillaries are capable of active contraction and dilatation; we have identified the powerful effect that may be exerted on the larger blood vessels and capillaries by the products of the ductless glands and by substances produced in the metabolism of the tissues. We have gone farther than this: we have by means of artificial methods of stimulation identified various vascular reflexes; we have found that the heart when isolated from the body can deal with an increase in the rate at which venous blood is supplied to it by altering its amplitude of beat without any variation in rate, though if its nervous connections are intact an acceleration of the venous return causes a reflex increase in the pulse rate, the antithesis of the reflex retardation caused by an undue rise of arterial blood pressure.

But what does all this seemingly exact knowledge amount to? Are we not really only showing up the potentialities in the circulatory system? It may be argued that we shall gradually build up the whole as our knowledge of the component parts becomes more complete, but I retort—can you build up the whole without a preliminary notion of its characteristic qualities? Surely before we attempt an explanation we must know what it is that we are trying to explain. The circulation has to supply oxygen and foodstuffs to the tissues, it has to remove CO_2 and other waste products from them. Well, what are the claims made on the circulation in everyday life? We can answer that question in the case of man from our knowledge

of the changes in his metabolism under different circumstances. Here then are the demands: how does the circulation actually accomplish its task; what are the facts of the case?

Thirty years ago Zuntz and Hagemann succeeded in making observations on the output of blood from the heart in a horse by a method which involved operative procedure, though this did not interfere with the animal's capacity for drawing a load, and these experiments afforded the first reasonably definite information as to the degree of alteration of the cardiac output caused by vigorous muscular work. More recently methods have been developed for determining the circulation rate in man, and with the help of these we are beginning to find out under different conditions of natural bodily activity the actual quantitative variations in the amount of blood expelled from the heart, the extent of the changes in gas content of the venous blood entering the lungs, and the relative parts played by the two factors of increase in pulse rate and alteration in the systolic discharge at each beat which we have already identified as the potential means by which the heart can respond to alteration in the demands made upon it.

This is, however, only the beginning of our task. To ascertain the full facts of the regulation of the circulation and its adaptation to the varying needs of the body is a more difficult problem than the regulation of the breathing. We may know a little about the behaviour of the heart, but the heart is, after all, only the pump. We have still got to deal with the question of the distribution of the blood to different regions of the body. In spite of all the work that has been done in the past, our ignorance on this side of the question is still profound, and the darkness will not be dispelled until we know much more about what happens in the normal animal. I am not going to assert that human physiology has succeeded in this case in giving us a solution where the method of direct experimentation on lower animals has proved inadequate. It certainly has not as yet, but I do maintain that the knowledge that we have gained from a broad study of the whole respiratory function in man has at least emphasized the nature of the problem that confronts us, and has given us some conception of the difficulties that we have to face. Suppose we expose and stimulate some nerve and find that this leads either directly or reflexly to contraction of the blood vessels in some region of the body. All we have done is to show up a route along which it is possible for vaso-constrictor impulses to travel. We must go much farther than this: we must ascertain whether such impulses do follow this route during normal life, and if so, when; what variation may be exhibited in the frequency or strength of the impulses and in the magnitude of the resultant effect; what is the natural stimulus which initiates these impulses and causes them to vary from time to time, and what this variation may mean to the tissues in the area supplied by the blood vessels in question.

What we have in fact got to find out are the actual quantitative changes which occur under natural conditions in the general circulation, and then we must try to interpret these in the light not only of our knowledge of the potentialities of the circulatory system itself but in relation also to the varying activities and demands of the tissues.

What matters to the tissues of the body is that each and all of them

should at all times be furnished with the right amount of blood to satisfy their needs, however much these needs may vary. The general circulation rate and the calibre of the blood vessels must be accurately adjusted lest in satisfying the needs of some organs others should be starved, and until we can express this adjustment in quantitative terms we cannot hope to assess correctly the relative importance to be attributed to physico-chemical, nervous or hormonal factors in ensuring the necessary co-ordination. We devote enough attention in all conscience to the measurement of blood pressure, and no doubt this has materially aided us to appreciate the cruder and more elementary phenomena associated with the circulation, but when we look at the question from the point of view of the tissues and are brought face to face with the true functional aspect of the circulation, blood pressure as such becomes a more or less irrelevant detail. The failure lies in the fact that we cannot construe our measurements into what is of true functional significance, namely, changes in the rate of blood flow. We cannot of course expect an adequate supply of blood without an adequate driving force or blood pressure, but the requisite force at any moment must depend on the precise setting of the calibre of the blood vessels, and in regard to this we must confess that we have still got a vast amount to learn. The adaptation and accommodation of the circulation to meet the requirements of the body is the real essential that we have to study, and it is not until we have gained an insight into the quantitative changes of the local and general circulation, and the factors on which these depend, in the normal and functionally intact animal, that we shall be able to claim to understand the circulation of the blood.

We meet with exactly the same difficulties in the case of the other functions of the body when we try to translate potentialities into actualities. Take the case of the kidney, for example. Controversy has raged for years as to whether the cells in the different regions of the kidney are to be regarded as playing an active or a passive rôle in the formation of urine. Observations on the anæsthetized animal or the isolated kidney are slowly solving some of the difficulties, but even when we have reached agreement on the vexed question as to the degree to which the properties of filtration, active re-absorption and specific secretion can be ascribed to the kidney epithelium we are only at the beginning of our troubles, for we have still to ascertain how these different potentialities may be brought into play to account for the normal behaviour of the kidney. Observations on man have already done much to show the surprising delicacy with which the kidney responds to alterations in the composition of the blood, and to throw suspicion on the justice of conclusions based on experimental alterations of so gross a character that they could have no counterpart in normal life. The kidney is not acting as a simple drain; it is playing a perfectly definite part in helping to maintain the composition of the blood normal, and experiments on human subjects have thrown into strong relief the interdependence of the kidney and other organs in maintaining this normality.

The physiological regulation of the hydrogen ion concentration of the blood and tissues, a problem to which so much attention has been directed in recent years, affords an instance of the interaction of the organs in

promoting the normal working of the body. We cannot restrict ourselves here to a consideration only of the physico-chemical properties of the blood and tissue fluids, for the initiation of any alteration in the hydrogen ion concentration of the blood will at once result in a change in the activity of the respiratory, circulatory and excretory organs, the net effect of which will be to render the actual change of hydrogen ion concentration a great deal less than would otherwise be the case. Thus we see that the reactions provoked in response to changed conditions will tend to preserve the functional capacity of the body by limiting the changes in the immediate environment of the tissue cells.

The experimental investigation of man has furnished the clearest evidence of co-ordination of organ activity of this type. The reaction to muscular work is a case in point, for the increased activity of the respiration and circulation, by hastening the elimination of CO_2 from the body, helps to keep within reasonable limits the rise of hydrogen ion concentration in the blood caused by the passage of greatly increased amounts of CO_2 , and even lactic acid, from the active muscles into the blood stream, and at the same time maintains the oxygen supply. The limitation of the changes of hydrogen ion concentration in the blood, which is brought about by simultaneous changes in the activity of the respiratory centre and in the rate of excretion of acid and basic radicals by the kidney, has been demonstrated in man when acid or alkali is temporarily withdrawn from the body during the secretion of the digestive juices just as clearly as when an excess of acid or alkali gains admission to the body owing either to alteration of the diet or to the deliberate ingestion of alkalis, such as sodium bicarbonate, or substances, such as ammonium chloride, which lead to the liberation of acid within the body. There is evidence, too, from experiments on man that in the tissues themselves a still narrower limitation of changes of hydrogen ion concentration than in the arterial blood may be attained by local acceleration or retardation of the circulation.

In the influence of training on a man's capacity for strenuous muscular exertion, and in the process of acclimatization to the reduced oxygen pressure in the atmosphere at high altitudes—a process to which changes in the activity of the respiratory organs and kidneys and in the composition of the blood all contribute—we get further examples of the co-ordinated accommodation of organ activity to alteration in the conditions of life.

The more we examine the normal behaviour of the body the more is it brought home to us that the maintenance of the natural life and integrity of the organism depends on the closest co-ordination of all its different parts; all the organs are interdependent, and can have no real existence save as active components of a corporate whole. Life consists of a delicate balance of all the different functions, a balance that is being continually adjusted so as to ensure the maintenance of the true functional capacity of the organism in its struggle for self-preservation in a constantly varying environment. As an agent in securing this exquisite co-ordination a physico-chemical change in the blood stream may at one moment be prominent, at another moment a nervous reflex. Very frequently both factors co-operate, the physico-chemical change ensuring perhaps strict quantitative co-ordination of activity, the nervous reflex offering

the advantage of speed and simultaneity of response in parts of the body remote from one another. The two factors are not antagonistic; the one is not gradually supplanting the other, but each plays its part in its own peculiar sphere.

When we recognize the exactness of the co-ordination of the different functions in normal life we cannot fail to appreciate the relative crudity of some of the experimental methods we are forced to use in physiology. Methods that interfere with the mutual interdependence of the different organs can only give us a partial insight into the problem of life, and if we use these methods we must correct the impression that we gain by comparison with the true normal.

In attempting to put before you what appear to me the outstanding contributions which we owe to human physiology—the quantitative changes of organ activity associated with normal life, the close functional linkage of the different organs, and the power of adaptation to altered circumstances—I have, as is only natural, dwelt upon those branches of physiology with which I personally have been mainly brought in contact. But the study of human physiology is by no means limited to these fields, and we must not forget that we owe much to work undertaken primarily in the cause of clinical medicine, a debt which we can repay in part as we develop new methods by which we may investigate the physiology of man. Instances of spontaneous derangement of function in man have helped very considerably to elucidate the influence of the ductless glands, and modern methods of clinical examination have amplified our knowledge of the processes of digestion and the movements of the alimentary canal; while the neurologist is widening the field in which we can find scope for the application of the fundamental principles of reflex action which, based originally on the experimental investigation and analysis of the properties of the lower nervous system, have already been extended by the physiologist to embrace some at least of the functions of the cerebral hemispheres in the intact animal.

When we review the development of physiological thought in the last quarter of a century we cannot close our eyes to the fact that investigations on man are becoming of increasing importance, and that the contribution made by human physiology does not involve mere matters of detail. There is something of far more importance than that, for the evidence of balanced interaction of the functions of the different organs with the preservation of the functional integrity of the whole, which is so convincingly brought home to us in experiments on the human subject, has made us appreciate that in physiology the organism as such, be it man or one of the lower animals, is our unit, and that, whatever methods we may employ in our investigations, we must keep that essential fact before us. In the problem of what is meant by life we have set ourselves the most complicated puzzle in existence. I firmly believe that human physiology, limited though our knowledge may as yet be, has already given us a vague glimpse of the final picture which we hope to complete, and has put us in a better position to fit together the individual fragments, the tiny components of the puzzle, which we have been accumulating in such profusion in years past.

The truth is that we cannot confine ourselves exclusively to any one

method in physiological investigation. Unless we deliberately study the normal organism in its entirety I do not see how we can gain any adequate conception about what is really implied by life, but once we have begun to gain that conception we can employ the methods of detailed analysis about which I have spoken earlier with hope of real success. There has been a tendency of late to differentiate the subject of bio-chemistry from physiology, but this distinction, though it may have the merit of administrative convenience, can have no real justification if the ultimate aim of the physiologist and bio-chemist is, as I suppose, the same, namely, the investigation of the nature of living processes. Physiology and bio-chemistry in fact merge into one another, and if we call to our aid the resources of chemistry and physics that need not imply that we are any the less physiologists, but we have to be on our guard that we do not by imperceptible degrees turn from the path of biology into that of pure chemistry and, in so doing, miss the goal that we set out to attain. If an example is needed of the application of chemical and physical methods of investigation to the normal living organism, I would point to the work that has been done on human physiology, for it seems to me that a just claim may be made that in that there is represented at least one aspect of true chemical physiology.

I have now tried to show you something of the part that has already been played by human physiology in the study of the phenomena associated with life, and I want to turn to a different aspect with a view to urging a wider extension of the study of this branch of physiology. In our enthusiasm for research we are apt to overlook the fact that unless our teaching can keep pace with our research the general advance of learning must be seriously impeded. Age must give place to youth, and we must do our best to hand on to those who will succeed us the knowledge which we have inherited and to which we have added in our own generation, so that they may be able to go forward from the point where we are obliged to leave off.

I cannot help feeling that our teaching of physiology would be more satisfactory if human physiology occupied a more prominent position. I am not thinking so much in this connection of advanced teaching, for the number of students who take advanced courses is relatively small and it is fairly easy to arrange suitable work for limited numbers. The great majority of students who take up the study of physiology do so as a preliminary to a medical career, and but few of them in the end pass on to advanced courses, and it is of the elementary teaching of physiology required as a preliminary to the study of clinical medicine, or an antecedent to more advanced honours courses, that I wish to speak.

So far as the theoretical side of physiology is concerned, books enough and to spare are available; and if the student is dissatisfied with his text book or his teachers he can turn, unless he is appalled at the prospect, to the ever-increasing number of monographs, reviews and special volumes which offer to him information on almost every conceivable branch, however obscure, of physiology. It is, I think, the practical instruction in physiology with which we may legitimately find fault. We are, I suppose, in part tied by tradition, in part handicapped in our laboratories by the accumulation of apparatus of bygone days, and it is easy to point

to lack of funds as an excuse for continuing in the same path as those who preceded us. The fact remains that so far as elementary practical physiology, as distinct from bio-chemistry, is concerned, reliance is still largely placed upon an experimental treatment of some of the rudimentary phenomena exhibited by amphibian muscle and nerve. I do not deny that some of these experiments do afford information which is of value to the student, but I am also prepared to maintain that others are merely artificial, and but relics of the past that would be better omitted, and that they in no way represent the standpoint of the present day in this branch of physiology. But though experiments on muscle and nerve still figure largely in the physiological curriculum, it is noticeable that simple experiments illustrating the progress of more recent years are gradually being introduced, and that in some laboratories a far more serious attempt has been made to remodel the curriculum than in others, and to afford an opportunity for gaining acquaintance with some of the facts of human physiology.

Such a change in outlook is very welcome. When dealing with a subject which is so rapidly progressive as physiology I feel that we are bound to reconsider our methods of teaching at intervals, if we are to render those whom we instruct reasonably conversant with the actual state of knowledge at the time; mere addition to the curriculum is of no use, what is needed is reconstruction. Do not think that I say this in any carping spirit. After all, some facts have become so firmly established in the past as to have become axiomatic, and we must be content to accept many of these without constant repetition of their proof if time is to be found to give the student some indication of the experimental developments which have led to alteration and extension of our earlier conceptions. If practical courses of instruction are to play their full part and not to degenerate into simple exercises in skilful manipulation they must be brought into line with current physiological thought; they must, even though the experiments be simple, help to convince the student of the meaning and truth of what he reads. I am certain myself that a serious attempt to incorporate even in elementary courses experiments on human physiology will be amply justified.

I confess frankly that in my own case if I want to understand the facts of physiology I have to think of what they might mean to me in my own person; I cannot think easily in terms of lower animals. I have got to translate the information before I can use it. I do not believe that I am peculiar in this respect. Many a student would, I am sure, acquire a deeper and more real interest in physiology if his attention were directed to some of the essential facts of human physiology at an early stage in his instruction. Show him something of what really happens in himself in the natural course of his daily life, awaken his curiosity about the way in which these events are actually accomplished, and he will then more readily understand the significance of what he learns from other sources. As it is, he runs the risk of being overwhelmed by the literature of the subject that he is studying and of losing himself in details which he cannot place in the right perspective: he too often fails to see the wood for the trees. The quantitative interdependence of function in the body can be well illustrated by simple experiments in

human physiology ; and a more convincing introduction to those quantitative conceptions which must form the basis of physiology, as of other branches of natural science, can be gained, I think, in this way than by, say, a few quantitative bio-chemical analyses which, essential though they may be in themselves, can hardly be more than exercises in method in the early days of a student's career.

These students are for the most part going to follow the profession of medicine, and in the short time available our aim must be to develop their powers of thought and initiative that they may be the better equipped to face the future when they go out into the world ; and if they leave us with only the recollection of a medley of seemingly disconnected facts, it is quite intelligible that they may fail to grasp what physiology really means, and that a gulf, for which there can be no justification, will deepen between physiology and medicine. Physiology is not medicine : the physician sees a side of life which the physiologist does not meet in the cold aloofness of the laboratory. The art of medicine is not based merely on the application of skilled technique ; it demands in addition a full and sympathetic comprehension of human nature with all its hopes and fears, its frailty and courage. And yet the more the physiologist can find out about the characteristics of normal life the greater will be his service to medicine, for a knowledge of the normal cannot but help us to estimate with greater certainty the influence of the abnormal, and the underlying principles of adaptation of organ activity which we as physiologists recognize in the functional changes which exhibit themselves in everyday life, and in the reactions to alterations of environment, have their counterpart in medicine in the natural efforts at compensation for the effects of injury or disease, a compensation which it must be the aim of the physician to encourage and assist.

And there is another field in which scope may be found for human physiology. In the growing complexity of the modern world the improvement of the general standard of life is a matter which appeals to all of us. Physiologists have already played a prominent part in investigations into the means by which conditions may be improved and risk reduced in industrial processes, into the factors which affect the efficiency and welfare of the working classes, and into the influence of diet on health. Problems such as these, whose solution is of direct benefit to the community at large, call for the practical application of physiological principles. We ought not to regard applied physiology as something distinct, as something to be divorced from the more academic study of theoretical physiology ; it should be looked upon as the natural extension of our researches in the laboratory. These practical problems in their turn often suggest new lines of inquiry, new methods of approach, by which the science of physiology may be still further advanced.

The horizon stretching before the physiologist is a wide one, and, no matter whether he intends to adopt an academic career in pure physiology or to follow the path which leads on to medicine or to hygiene in its broadest sense, I am convinced that a study of human physiology will introduce him to some of the fundamental facts of life, and by giving him a guiding line of thought will help him to make his way through a maze of minutiae and speculations in which he might otherwise get overwhelmed.

SECTION J.—PSYCHOLOGY.

MENTAL UNITY
AND MENTAL DISSOCIATION.

ADDRESS BY

WILLIAM BROWN, M.D., D.Sc., M.R.C.P.,

PRESIDENT OF THE SECTION.

It is important to realise that the problem of mental unity and dissociation is in direct relationship to the problem of unity and dissociation in the physical and physiological spheres. The point of view from which we should first approach it is that of biology. The general tendency throughout evolution seems to be towards the building up of totalities or wholes, in which each separate activity takes place in relation to the whole. The general conception is not that of a purely mechanistic scheme in which we begin with particles of matter and consider how they interact with one another to produce a more and more complex system, but one in which there is a guiding unity from the beginning. We may indeed, as metaphysicians, assume that there is a guiding unity of the entire universe. But short of such an ultimate generalisation we find that observation itself reveals this tendency towards a progressive development and multiplication of unities, in relation to which individual activities occur.

In one sense, biology may be regarded as the most fundamental of the sciences, and even the simpler physical and chemical activities occur as parts of systems, which may be likened to organisms in having an environment to which their reactions are adjusted. This biological point of view needs for its completion the psychological point of view, which is not something distinct from the biological, but a continuation of it. Psychology is a completion of biology as a science, and gives further meaning to it. The unity of the organism becomes more intelligible when we think of it as a mental, and in part a conscious, unity. It is a unity in plurality. Physically, the organism is a unity of parts in spatial relation to one another; psychologically, it is a system of mental tendencies in relation to one another. What we find physically is a reaction to an environment in the form of reflex action, simple or conditioned. Psychologically, response to external stimulation is the satisfaction of conation, and, at higher levels, satisfaction of desire, &c. Biologically, it is the struggle for existence, with all that this involves. Psychologically, it is a conscious striving first of all for something that the individual does not know—towards a goal which he gradually realises, gradually learns to understand as he achieves it or fails to achieve it. However helpful the biological concepts of tropisms and conditioned reflexes may be as explanatory factors, the psychological point of view throws further

light upon the situation. The ultimate factor that has to be considered is something that is *purposive*—a general striving—which factor has to be assumed in order that the theory of conditioned reflexes will work.

Unity of mind, then, is something which develops. In its general form it is there from the beginning, but it only exists in relation to a multiplicity. There is a one-and-many relationship from the beginning. Moreover, the individual himself is, to some extent, an abstraction. He belongs to a species. He has a history, and his history is, in part, the history of the entire species. The history of the species is part of the history of organic evolution, and the history of organic evolution is part of the history of the Universe—if, indeed, we may think of the Universe itself as having a history. But within the individual experience there are partial activities that may struggle with one another just as individual members of a species may compete with one another, and in this *nisus* or striving towards more complete unity and greater complexity and more adequate adaptation to environment, the process of dissociation shows itself as essential and normal. Right from the beginning we must realise that dissociation is just as normal and necessary as association. The mind as it grows must be able to reject, and also must be able to segregate one activity from another. Different activities must be insulated from one another to a great extent within the organism, just as in an electrical machine there must be insulation of the wires. This insulation is what is meant by normal dissociation or disjunction. And from the pathological point of view there can be disturbance in both respects—disturbance of association and disturbance of dissociation. Experiences may become associated in such a way as to blur the clearness of vision of the individual as regards appearances and values, just as, more obviously, dissociation may go beyond its proper function and tend to destroy the unity or totality towards which normal striving is directed.

The earlier associationist doctrine of psychology was unsatisfactory because, among other things, it failed to distinguish between the process of experiencing, or the act of experiencing, and the content or object of experience; and its aim seems to have been to describe the mind as a sort of mosaic of contents of experience joined up to one another according to the laws of association by contiguity and similarity. But association is primarily between the acts of experience. These acts of experience are differentiations of the fundamental striving—that which Spinoza called the *conatus in suo esse perseverare*, 'the striving to persist in one's own being.' This striving has an object. There is always an object—the environmental changes which the individual has to face—and corresponding with the complexity of the environment there is a complexity developing within this general striving, forming a complex system of conations. This conation involves the two other well-known aspects of cognition or awareness, and of feeling-tone. Associationist psychology erred in failing to allow due weight to the conative side, and in attempting to range the different kinds of feeling on a level with the different kinds of objective experience. But even according to the associationist scheme, dissociation or disjunction was necessary for a complete explanation of normal mental activity. Side by side with the principles of association by contiguity and similarity, there was the principle of dissociation by

varying concomitance. Only by such a principle could the important processes of discrimination, comparison and abstraction be brought within the circle of associationist doctrine. The general scheme of explanation was wrong, in that it dealt with contents of experience when it should have been dealing with acts of experience; and the general scheme of mental activity which we put in the place of this associationist scheme is that of systems of mental tendencies included within, and in subordination to, a wider system—tendencies towards knowledge and action, and involving feeling. One such system of explanation is that in terms of instinctive-emotional dispositions organised within sentiments, with the sentiments in their turn subordinated to one all-inclusive sentiment or master-interest. A sentiment is an organisation of emotional dispositions centred about the idea of some object. What are organised are not the presentations or representations, not the contents of experience primarily, but the processes or acts of experience. The tendencies of experience, and the activity and organisation of these tendencies, bring with them an organisation of the objects; and so our memories, which are retained and which are used for the retention of past experiences, fall into systems because the acts of experience corresponding to those memories fall into systems. And from that point of view we see that the dissociations of memory—the gaps in the memory continuum, known as amnesias—find their true significance in the segregation of corresponding acts of experience.

The question then arises, if we reject the associationist scheme according to which the mind is built up of presentations and representations cohering together in systems, are we to regard the unity of the mind as an aggregation of mental activities and tendencies? Are we to put in place of our mosaic of mental contents a collection or a colony of mental tendencies? The reply is 'No,' because we do not have these mental tendencies separate from one another—just coming together and cohering, just as we do not have the mental contents coming together and cohering. Both subjectively and objectively, we must assume at the beginning a generalised striving and mental tendency, with a generalised objective—*e.g.* 'the great big buzzing confusion' of which William James speaks as the world of the new-born babe—a continuum of sensation and movement on one side, and a continuum of mental striving on the other. The general mental striving which we assume at the beginning becomes gradually differentiated in relation to the needs of the organism, and the demands made upon the organism by its environment—a differentiation superimposed upon the differentiations accumulating in the history of the race, and handed on from generation to generation in the form of instinctive endowment and inherited aptitudes. The individual inherits not only separate instincts, but also the tendency towards an organisation of those instincts. He inherits the beginnings of sentiments, as well as instincts. He is already a one-and-many unity, with his mind a plurality of part-tendencies and processes, and his task in life is to carry that organisation to a higher stage. The demands made upon him by his environment bring with them movements in two directions—in the direction of greater unity and greater organisation, and also of greater complexity—a greater degree of differentiation and discrimination. Discrimination is necessary

because he has not only to accept, but also to neglect or reject, and this neglecting or rejecting involves dissociation, just as acceptance involves association.

As regards dissociation in pathological cases, the writers of the last generation thought of this in terms of associationist psychology, and in the doctrine of Prof. Pierre Janet one finds that standpoint still apparent. In his description of cases of hysteria and multiple personality, he implies a general background of explanation, according to which personality may be regarded as a synthesis of mental presentations some of which can be split off from the main mass. This view is similar to the colonial view of personality which we find in the writings of Ribot. But if we remind ourselves of the fact that experience involves an act of experiencing, we see that the situation is rather different. The power of recall is an essential aspect of conscious memory. On the other hand, unconscious memories are unconscious or latent mental activities directed towards past events. They are not passive, but involve a certain amount of mental energy. And so we pass from Pierre Janet's theory to the theory of Prof. Sigmund Freud, and we find that the dissociation which is taken as a fact in Janet's theory is explained in Freud's theory in terms of mental conflict and repression. These memories become inaccessible to the individual because the mental tendencies corresponding to them are in conflict with other tendencies of the individual and incompatible with his more fundamental interests. So they are extruded by an active process of repression—they are barred from consciousness.

That process of repression and extrusion, though pathological in these cases, need not be necessarily so. We must not look upon extrusion itself as essentially pathological. It is because we have restricted the word dissociation so much to the pathological side that we find it so incomprehensible to us. It is because we have thought too much in terms of mental unity that cases of multiple personality seem to be inexplicable. Actually the most normal mind is a multiplicity. We are all many selves. We have to face the world from many different angles. We have many different interests. Interests in the most normal mind may conflict and be incompatible with one another. And it is a condition of mental health that such conflict can be resolved by elimination or by a higher synthesis. What makes the dissociation of multiple personality pathological is that the elimination is not complete—that dissociation in normal mental activity is a successful rejection, and that dissociation in a pathological case is unsuccessful—is an incomplete and therefore an unsuccessful rejection. A tendency that is pathologically repressed is, as it were, rejected and accepted at the same time—rejected by clear consciousness, but still clung to by the mind.

It is misleading to look upon the problem of mental dissociation and multiple personality as something standing by itself, as if we understood mental unity and were perplexed by the appearance of multiplicity. Multiplicity is an aspect of the normal mind, just as much as unity is, and unity needs explaining just as much as multiplicity does. Those two problems must be solved together, and kept in relation to one another all through.

Many of the classical cases of multiple personality are fully explained

along these lines. They are cases of alternating personality with reciprocal amnesia, as it is called, in which each personality is unable to recall the experiences of the other. The two individuals A and B alternate with one another. A has his own system of memories and, when he disappears and makes way for B, B has his system of memories distinct from the memories of A. We may explain this in terms of two general systems of interests which are mutually incompatible and in conflict with one another. As a rule, one part of the personality is more fundamental, *i.e.* more stable, than the other. But difficulty arises in cases where one personality is shut up within its own memories and experiences, while the other personality has access to those memories as well as to its own. A may have his system of memories but be quite ignorant of B, except from indirect evidence, whereas B not only has a special set of memories, but also has direct knowledge of A's memories, thoughts and feelings. This is a difficult problem which needs to be faced. We find an analogous, though not identical, situation in most cases of deep hypnosis. When a patient passes into the hypnotic state, he may remain fully aware of his waking consciousness, and may have free access to the memories of his waking self. But on awaking he does not, as a rule, remember his hypnotic experiences. The relation is a one-sided one. The hypnotic personality is acquainted with the waking personality, and all its memories, but the waking personality is not acquainted with the hypnotic personality. The range of the hypnotic personality is wider than the range of the waking personality. This similarity between one-sided multiple personality and the hypnotic personality is significant, when we remember that such cases have been investigated by the hypnotic method. Pierre Janet, Morton Prince and others used the hypnotic method in studying cases of multiple personality, and the criticism has been made against them that in doing so they were manufacturing personalities—that the personalities were artifacts produced by the method. Everyone recognises that these investigators are psychologists of exceptional ability and circumspection and honesty of purpose, thoroughly trained and alive to the possibilities and difficulties of their method. We cannot dismiss their observations as false observations, or as misunderstandings on their part. But we must nevertheless allow for the influence of the process of hypnosis in the result, and as contrasted with that earlier period of investigation—the hypnotic period in psycho-pathology—we find that, now that hypnosis is seldom used and has been replaced by deep analysis, cases of multiple personality are not on record. The psycho-analysts to-day seem to have no such cases to report. Moreover, if we contrast the very large number of cases of severe nervous disturbance caused by the late war with the absence of cases of multiple personality there, we may become still more impressed by the argument that it was the persistent use of the hypnotic method that was mainly responsible for the complexity of most of the earlier cases reported.¹

¹ Cases of extensive amnesia, fugues, &c., were numerous during the war; but the first aim of the army doctors in the battle areas was to remove these amnesias and reassociate the patients as quickly as possible, so that the latter might be either returned to the line or sent down to the base with the minimum of delay.

The movement of thought is always towards system and unity. Thought abhors hard-and-fast distinctions. Thought is baffled by cases of multiple personality because they are so different from the ordinary cases of everyday life. If we can build a bridge between one group of cases and the other, then we may feel that we are likely to have not only a more satisfying but a true explanation of the situation.

We must therefore approach the question of dissociation from the normal side—as manifested in a relatively normal mind. No mind is completely normal, since no mind completely solves its problems from day to day, and it is the failure to solve mental problems which is one of the general causes of the symptoms of psycho-neurosis and mental disease. Dissociation and multiple personality are not to be contrasted with association and mental unity. Pathological dissociation should be contrasted with the dissociationist processes of the normal mind. It should be regarded as a failure of the normal process of dissociation.

The unity of the normal mind, although it is there from the beginning, is a striving towards a more and more complete association; it constitutes an urge to a greater and greater degree of completeness of systematisation and inclusiveness, but it is never really complete. In the most normal mind there is a falling away from complete unity. There is in the activity of this unitary mind not only a normal process of disjunction or dissociation, but also a certain degree of abnormal dissociation. In cases of multiple personality this abnormal dissociation has become so pronounced as to be apparent to the whole world. The process of deep analysis or psycho-analysis fails to reveal cases of thorough-going multiplicity, and the reason is that the process itself is a process of unification. As the individual is being analysed, the failures of adaptation in his past life are cleared up, so that his mind is enabled to work more and more normally. Analysis is not a good term for this process. It is more than analysis, it is a process of self-revelation or *autognosis*. The individual learns to know himself better, and in the process of analysis there is actual development of the mind going on. There is a development in the direction of the normal and the unitary. Any dissociation that is encouraged by the method is a normal dissociation, not an abnormal dissociation. It is only another expression of the same truth when we say that repressions are overcome in the process of analysis, because repressions are pathological dissociations—dissociations that are not complete and not thorough going.

In contrast with this process of autognosis, the process of hypnotic investigation carries with it a tendency to abnormal dissociation. A person who is easily hypnotised is a person who is already, to some extent, dissociated; in hypnotising him we take a wedge, as it were, and drive it into his mind and split him up still more. No wonder the results give us an appearance of dissociation; but it would be very dangerous for us to take these results at their face value and draw inferences from them as to the structure of the normal mind, or even of the mind of the person we have been experimenting with. This general line of criticism seems valid as against such a theory as that of Prof. W. McDougall in the last chapter of his 'Outline of Abnormal Psychology,' in which he works out a theory of the Self as a system of monads which form a hierarchy, in which there is one dominant monad, the conscious self, and a whole

number of subsidiary monads that are, in a normal mind, adequately subordinated to the chief monad and are in relation to the chief monad through telepathy²; but in a case of multiple personality one of these subsidiary monads may break loose and become insubordinate. This is an ingenious theory, and it may be true, but in the present state of our knowledge it would seem to be a case of explaining *obscurum per obscurius*. Telepathy may be a fact, but it is something about whose *conditions* we know next to nothing, and therefore not very suitable to take as a fundamental factor in an explanation of the working of the mind.

The mind can act at different levels on different occasions and under different circumstances. In many of the classical cases of multiple personality, the subsidiary personalities represent a regression to more juvenile forms of behaviour and of ethical valuation. This is clearly apparent in 'Sally Beauchamp' of the Miss Beauchamp case, and in the 'B' personality of the 'B.C.A.' case (Morton Prince). Such manifestations are not accurately described as 'split-off' personalities. Indeed, any spatial metaphor is inappropriate. In other cases the tendency to dramatisation, natural to the human mind, may play an important part. Mutually incompatible ideas of character may be simultaneously or alternately aimed at, and identifications in early life, based on love and admiration for relatives, &c., may introduce incompatibilities which reveal themselves under circumstances of stress in later years as the grounds of pathological dissociation.

As regards the problem of the *removal* of pathological mental dissociation in hysterical patients, much was learnt from the wide range of cases dealt with during the war. While treating shell-shock cases in the field in France, I found that a large proportion of the cases showed a more or less extensive amnesia for events that had occurred immediately after the shell explosion. These patients were easily hypnotised, and under light hypnosis the lost memories could be immediately restored. But I soon discovered that if I recalled at the same time the terrifying emotion that had originally belonged to these experiences, there was a tendency for the accompanying hysterical symptoms—deafness, mutism, tremors, paralysis, contractures, &c.—to disappear spontaneously, without the necessity of giving explicit suggestions to this end. The more complete I made the working-off of the emotion, or the 'ab-reaction,' to use Breuer's original term, the more complete was the recovery. In cases seen by me previously in England, I had also restored lost memories by light hypnosis, but had not produced intense emotional revival and had not seen collateral symptoms disappear. But again, towards the end of the war, I was seeing more chronic cases in Scotland, and then found that amnesias of longer standing could be cleared up with accompanying ab-reaction of the emotion of fear; and that with the ab-reaction there was observable that tendency for the collateral symptoms to disappear at the same time, such as I had observed so frequently in France.

These are observed facts, and I endeavoured to show in a paper in the *British Medical Journal* some years ago³ that they could be explained in terms of a theory of reassociation. The amnesic patients fresh from

² Unlike the monads of Leibniz, which 'have no windows,' and are in a relation of pre-established harmony.

³ 'Hypnotism, Suggestion, and Dissociation,' *British Medical Journal*, June 14, 1919.

the trenches showed a two-fold dissociation, namely (1) a dissociation of the memory of events immediately following upon the shell explosion from memories of earlier and later parts of the patient's life; and (2) a dissociation of these memories, as mere intellectual awareness, from the accompanying emotional reaction of fear—tremors, sweating, mutism, paralysis, &c.—which are of a physiological nature. The physical reaction of fear, thus dissociated from its psychical counterpart, had become relatively permanent instead of being transitory. The patient no longer felt the emotion of fear—at least, of just that fear which the shell explosion had aroused—but did show its physical manifestations in the form of hysterical symptoms. By re-arousing the whole of the lost experience in all its emotional vividness I overcame *both* dissociations. The physical manifestations became linked up with their psychical counterpart, and this in its turn was linked up with earlier and later memories of the patient's life. In this way the mind was completely resynthesised, and the physical symptoms came once more under the sway of the entire mind (the complete personality) and could disappear.

In addition to ab-reaction, I advocate the thorough thinking out of the whole psychological situation by the patient, so that he may be brought eventually to understand himself adequately. This is the process of autognosis, or self-knowledge. The patient is encouraged to obtain as objective a view of his entire mental condition as is possible.

C. G. Jung⁴ has explained the beneficial effects of ab-reaction in terms of 'transference.' By transference is meant the emotional rapport (conscious and unconscious) which springs up between patient and physician, and which enables the patient to live again, in the course of an analysis, through earlier experiences of his life in relation to the physician, and thus become freed from their harmful effects. The following case illustrates how ab-reaction can bring benefit without the factor of transference coming in. It is a case of a man of considerable education, who had for some years suffered from obsessive fear, the origin of which he could not fathom. He would wake up in the morning with this fear weighing upon his mind. After reading about the method of ab-reaction, as used in treating shell-shock patients, he thought that he would try to cure himself by a similar method. He endeavoured to recall earlier and earlier memories of his past life, using the method of concentration—to all intents and purposes producing a light degree of self-hypnosis. At length he seemed to get this memory: it was half a memory, half a waking vision. He seemed to be in a sort of native compound in India. He experienced intense heat, such heat as he never remembered experiencing in his life before, and seemed to see a black kid lying on the ground with its throat cut and blood pouring out of the wound. He felt intense terror as he went through this experience. This terror grew and grew 'like a bubble.' It got bigger and bigger and at last burst, and all at once the fear began to subside again and eventually disappeared, and he remained free of it afterwards. So far as one could make out—he came and told me of it afterwards; I had not treated him at the time—he had cured himself of the fear by bringing up this memory. He could

⁴ He writes: 'It must, above all, be emphasised that it is not merely the rehearsal of experience that possesses an unconditional curative effect, but the rehearsal of experience *in the presence of the physician.*'—*Brit. Journ. Med. Psych.*, vol. ii, 1921.

not be certain that the memory was a real memory, but thought that it probably was, because he had lived in India up to the age of two, when he left for England and had not returned since. It was thus probable that it was a real experience; if not so in all its details, the central kernel of the experience was probably real, and its recall was effective in curing him. It will be noticed that he did not ab-react this experience in relation to another person. He was not in a doctor's consulting-room, telling the doctor what he could remember. He was by himself. He had not even gone to a doctor beforehand, so that it could not be described as a transference towards the doctor in the latter's absence. He had not applied to any doctor for treatment at that time. He came on to me afterwards, simply to talk the matter out still further, and to learn whether he had been working on the right lines, and how he should proceed in order to ensure that the fearsome experience should not return. An example like this is a refutation of the view that the only beneficial effect of ab-reaction is the transference. Transference is indeed often the chief factor of cure, and in many ab-reaction cases transference is an additional factor. But an example like this shows that ab-reaction by itself has therapeutic value, in contradiction to Jung's view.⁵

Ab-reaction of repressed emotion sweeps away the repression, and so frees energy which had been previously needed to hold the repressed memories apart from the rest of the mind and away from clear consciousness. This freed energy is thus put once more at the general disposal of the personality. The previous 'fixation' of this repressing energy and its deviation from the common fund of energy of the personality probably explains, to some extent, the feeling of fatigue that generally accompanies a psycho-neurosis.

The unitary personality, as an organisation of mental activities and mental powers, is not static but dynamic, and is in process of development throughout life. Although it carries with it, as a physical correlate, a unitary working of the brain and of other parts of the body, this does not necessarily involve complete dependence upon the latter for its continued existence. The question of personal survival of bodily death is one which can be intelligibly and scientifically put, and which is in theory answerable along the lines of scientific observation and inference. The investigations carried out by the Society for Psychical Research during the past fifty years are of this nature, and the Society's results and provisional hypotheses can rightly claim a place in modern psychological science. Nevertheless, if due allowance is made for the possible working of such factors as conscious or sub-conscious fraud, telepathy between the living, and chance coincidence, the scientific evidence for personal survival of bodily death is not very strong.

For more convincing reasons (apart from the pronouncements of revealed religion) in support of this belief we still have to turn to philosophy, and in modern philosophical theories of *value* we find arguments that are far from negligible.⁶

NOTE: At the meeting, this paper will be supplemented by descriptions of cases illustrating mental dissociation.

⁵ I record this case in *Talks on Psychotherapy*, University of London Press, Ltd., 1923, pp. 39-41.

⁶ I have set out arguments from theory of value in my *Mind and Personality*, University of London Press, Ltd., 1926, pp. 309-318.

SECTION K.—BOTANY.

SOME ASPECTS OF THE PRESENT-DAY
INVESTIGATION OF PROTOPHYTA.

ADDRESS BY

PROF. F. E. FRITSCH, D.Sc., PH.D.,

PRESIDENT OF THE SECTION.

SINCE the last meeting of the British Association two well-known figures have disappeared from the ranks of British botanists. Reginald William Phillips, after nearly forty years' service in the furtherance of Welsh University education during which he found little time for original investigation, used the years after his retirement to prosecute vigorously the work on marine Algae that had attracted him at the outset of his scientific career. That these promising researches were cut short, so soon after they were begun, is a source of very great regret to his many friends. Moreover, of workers on British marine Algae there are but all too few, and a reduction in their number represents a serious loss to science.

The sudden death of Abercrombie Anstruther Lawson, as a comparatively young man, is a heavy blow to British botany. His exceedingly careful work on the gametophytes and embryos of Gymnosperms will always remain as a model of what such researches should be. Lawson had enjoyed the rather exceptional experience of filling academic posts in three distinct quarters of the world, namely, in the Leland-Stanford University, California, in the University of Glasgow, and in the University of Sydney. At the last he occupied the Chair of Botany from 1912 till the time of his death, and we know enough of his many activities there to extend our sympathy to our colleagues in Australia at the loss they have sustained by his premature demise.

We have also to deplore the death of two well-known botanical artists—John Nugent Fitch, who worked so long for the *Botanical Magazine*, and Miss Matilda Smith, for many years artist at the Royal Botanic Gardens, Kew.

* * * *

In practically confining my address to the Algae, and more particularly to the freshwater groups, I need make no apology, for not only have I been a student of these forms for some twenty-five years, but it appears that the simpler Algae have never before been made the subject of an address to this section. My predecessor in 1925, Prof. Lloyd Williams, it is true dealt with the many points of interest presented by the Phaeophyceae, but my remarks will refer in the main to forms with a much simpler construction than these. Whatever view we may ultimately take as to the relation of the present-day freshwater Algae to the rest of the Vegetable

Kingdom, and I shall have something to say on that point anon, they represent the most elementary types of holophytic plant-life to which we are likely to have access. The probability that such forms will ever be found preserved in the fossil state in sufficient numbers and showing the necessary details of cell-structure to be of any value for comparative morphological study or for the elucidation of the mode of origin of the multicellular plant, appears at the best to be remote. A study of fresh-water Algae is, therefore, one of fundamental importance, not only because they illustrate various stages in the elaboration of a plant-body and afford some rough picture of the early beginnings of plant-life, but because it is in such unspecialised types that many important physiological problems have found and will find solution. From this point of view the absence of adequate facilities in this country for the direct investigation of these forms on the spot is much to be regretted.

The relation of the different types of construction, that can be distinguished among the lower Protophyta, to one another and to the more elaborate parenchymatous soma usual in land-plants must always remain in part a matter of conjecture. There are, however, certain definite facts which emerge from a comparative study of the simpler holophytic organisms and that have an important bearing on these problems. It is with these that I shall more particularly deal in the first place.

Parallel Evolution among Protophyta.

It is now nearly thirty years since the doctrine of the flagellate origin of the Algae became firmly established by the discovery in Sweden of *Chloramoeba* and *Chlorosaccus*. These two simple forms agreed with a number of others, already previously distinguished as Confervales by Borzi¹ and Bohlin², in a series of sharply defined characteristics, namely, the possession of yellow-green, commonly discoid chloroplasts containing an excess of xanthophyll and devoid of pyrenoids, the storage of the products of photosynthesis in the form of oil, and the possession of a motor apparatus consisting of two very unequal cilia attached at the front end. These and other minor characteristics served to separate out from the extensive group of the Chlorophyceae a small set of Algae which became known by Luther's name, Heterokontae.³ The large remainder of the Chlorophyceae were renamed Isokontae, a designation based upon the fact that here the motile stages bear equal cilia (commonly 2 or 4) arising from the anterior end. In the Isokontae the chloroplasts are often large and few in number and are commonly provided with pyrenoids; they contain the same four pigments as do those of the higher plants and, so far as we know, in roughly the same proportions. Most Isokontae, moreover, store their photosynthetic products in the form of starch.

Subsequent to this Blackman and Tansley in 1902⁴ performed a valuable service in issuing a revised classification of the Green Algae in which the two classes, Isokontae and Heterokontae, were clearly distin-

¹ *Stud. algol. Palermo*, II, 1895, p. 99.

² *Bih. K. Sv. Vet.-Akad. Handl.* xxiii, Afd. 3, No. 3, 1897.

³ *Ibid.* xxiv, Afd. 3, No. 13, p. 17, 1899.

⁴ *New Phytol.* i, 1902, p. 17 *et seq.*

guished, and the same course was adopted by G. S. West in the 'British Freshwater Algae' published in 1904 and by most other contemporary authors. Many of these followed Bohlin in regarding the Oedogoniales as a separate class, the Stephanokontae, while the designation Akontae adopted for the Conjugatae by Blackman and Tansley implied, though not quite definitely maintained, a distinct origin also for this group. This practice has been followed by many subsequent writers, although abandoned by Oltmanns in the most recent edition of his great work. He, however, in common with many other authorities, nevertheless segregates the Conjugatae from the remainder of the Green Algae. There can be no doubt that any separation of these two groups from the bulk of the Isokontae obscures affinities and cannot reasonably be defended, although it is true that both Oedogoniales and Conjugatae have developed along very specialised lines.

It is well to realise that the characteristics separating the Green and Yellow-green Algae, like those distinguishing the other great classes of pigmented Protophyta to be mentioned later, are essentially physiological, depending on the colouring matters present in the plastids and the types of metabolism associated with them, as indicated by the nature of the substances stored during photosynthesis. That these diverse classes are also in general characterised by other features, such as the number and arrangement of the cilia in the motile stages, the chemical nature and structure of the cellular envelopes, and sometimes by special peculiarities of the reproductive cells indicates that the physiological distinctions are fundamental and that they go hand in hand with other characters. In separating the Oedogoniales and Conjugatae from the Isokontae we are, however, carrying out a *tour de force*, since in the pigmentation of their chloroplasts, in the possession of pyrenoids with a 'starch-sheath,' in the storage of starch, and in the chemical nature of their cell-walls these two groups are altogether Isokontan. Nor do they stand more isolated from the bulk of the Isokontae than do many other recognised members of this class, such as the Coleochaetaceae and Vaucheriaceae. As regards the fringe of cilia of the Oedogoniaceous swarmer, which is supposed to have been a feature of the flagellate ancestry of the Stephanokontae, ciliary numbers other than the usual 2 or 4 are not unknown among the motile Volvocales, a matter to which I shall return later. One peculiarity of the Conjugatae, viz. the absence of all motile stages, is in no way confined to them, being found for instance in a large number of Chlorococcales,⁵ whilst it is not impossible, as Blackman and Tansley first pointed out,⁶ to relate the conjugation-process to the sexual fusion found in some species of *Chlamydomonas* (e.g. *C. monadina*) in which the gametes are provided with cell-walls. I think there can be no doubt that Isokontae, Stephanokontae, and Akontae all constitute members of the same phylum, however much they may have diverged from one another, and any attempt to separate them must obscure the essence of the present-day concept of the main lines of algal evolution.

It has been suggested to me by various of my colleagues that, having rejected Stephanokontae and Akontae as separate classes, I should abandon

⁵ Protococcales of other authorities.

⁶ *Loc. cit.* p. 168.

the name Isokontae and revert to the old designation Chlorophyceae for the Green Algae. Under this name, however, there were also originally included the Heterokontae and its use might thus prove misleading. In the following I shall therefore continue to use the designation Isokontae for all true Green Algae.

Already at the end of the last century practically every conceivable type of simple plant-body was known in the Green Algae, ranging from the motile or motionless unicell, through manifold colonial forms, to a more or less highly elaborated filament. This extremely varied somatic development corresponds to a remarkable range of habitat and goes hand in hand with a great diversity in reproductive processes. There is in fact no other group of simple organisms showing such a wide scope in all these respects. By contrast the Heterokontae, when first distinguished, included only relatively few forms. By degrees, however, many additional members have been discovered, and in the course of this century it has become increasingly apparent that there exists a far-going parallelism between these two classes, Isokontae and Heterokontae, which are so sharply segregated by their metabolism and other features that the vast majority of algal workers have regarded them as quite separate evolutionary lines, in no way related to one another.

Thus, in each class we have a series of motile unicells, *Chlamydomonas* and its many allies in the Isokontae, *Chloramoeba* and *Heterochloris*? in the Heterokontae, while the palmelloid type, with large numbers of cells embedded in a mass of mucilage, is represented respectively by the Tetrasporales and *Chlorosaccus*, &c. (Heterocapsales). The motionless, often spherical, unicell—we may speak of it as the chlorococcoid (or protococcoid) type of plant-body—is well represented in both classes, and in part the relevant forms are so similar that, prior to the clear recognition of the Heterokontae, they were classed in the same genus. Thus, many species of *Characiopsis* were first included in the Isokontan genus *Characium*, while the type-species of *Chlorobotrys* was first described as a *Chlorococcum*.⁸ The unbranched and the branched filamentous habits are met with in both classes, while the coenocytic *Botrydium* is now clearly established as a siphonous variant of the Heterokontan type analogous to *Protosiphon* among the Isokontae.⁹ On detailed scrutiny it is not difficult to find other points of parallel; thus, in both classes there are colonial forms with an analogous dendroid construction (*Chlorodendron*, *Mischococcus*), while in each the chlorococcoid type is represented by two series of forms, the one reproducing by zoospores and the other (azosporic) in which motility is completely suppressed. We are indebted to Pascher¹⁰ for first drawing attention to this striking degree of parallel.

The Heterokontae do not, however, exhibit anything approaching the multiplicity of forms that are seen among the Isokontae, in particular they do not appear to have evolved in the direction of the motile colony which is so well developed in some of the other classes. Also the filamentous members are few, and the siphonous type is as yet only known

⁷ *Süßwasserflora*, xi, 1925, p. 23.

⁸ *Bih. K. Sv. Vet.-Akad. Handl.* xxvii, 1901, Afd. 3, No. 4, p. 34.

⁹ Kolkwitz, *Ber. Deutsch. Bot. Ges.* xlv, 1926, p. 539.

¹⁰ *Hedwigia*, liii, 1913, p. 6.

to be represented by *Botrydium*. The less vigorous development of the Heterokontae, which is thus manifest, accords with the fact that only a few of the more specialised members of the class exhibit sexual reproduction and that this has not passed beyond the phase of isogamy. The oogamous Vaucheriaceae, at one time referred by some to the Heterokontae, are now by practically common consent regarded as outlying members of the Siphonales among the Green Algae.

The few ciliated members of Heterokontae, that are at present known, without exception show 'flagellate' characteristics; that is to say, they are devoid of a cell-wall, their plasma-membrane (periplast) is more or less rigid but usually admits of some change of shape, multiplication is effected by longitudinal division, the protoplast readily encysts, and sexual reproduction is not known to occur. Some of the palmelloid members (e.g. *Chlorosaccus*), possibly all, also show these features. The many motile and palmelloid types among the Isokontae are, on the other hand, for the most part on a higher plane of organisation and reproduction, being true Algae provided with a firm cell-wall and usually exhibiting sexuality. When, however, the parallelism between the two classes is recognised, the distinction between flagellate and algal organisation loses force, and it is realised that the assumption of 'algal' characteristics has taken place at an earlier stage in the evolution of the one and at a later stage in that of the other.

These conclusions, however, do not apply only to Isokontae and Heterokontae. It is now clear that, in *all* the classes of pigmented Protophyta, an analogous evolutionary sequence has been followed, but that the features associated with what may be called 'algal organisation' have appeared, if at all, at different points in the sequence in the diverse classes. It is no longer feasible to separate the Algae from the holophytic Flagellata as distinct groups of Protophyta. There is reason to believe that every series of holophytic Flagellates could potentially have acquired algal characteristics, although on the present evidence some have failed to do so.

These points are well illustrated by a consideration of Pascher's Chrysophyceae which, until relatively recent times, were only known to include a wealth of flagellate types, the Chrysomonadales, whose members on the whole favour pure waters and seem to attain a maximum development in the cold streams and pools of mountainous tracts. They are not, however, without their marine representatives (Coccolithophoridae) and also appear to play a conspicuous part in certain kinds of salt-marsh.¹¹

The Chrysomonadales are distinguished by a golden-yellow pigmentation of their plastids due to the presence of various accessory pigments, and by storage of the photosynthetic products in the form of oil and of usually rounded lumps of a highly refractive substance known as leucosin, the chemical composition of which is unknown; endogenously formed silicified cysts with a very distinctive structure¹² are also peculiar to this class. The chromatophores are parietal, relatively large, and generally only one or two in number. In the numerous motile individuals the cilia are always borne at the front end, but three distinct series can be

¹¹ Conrad, *Archiv f. Protistenk.* lvi, 1926, p. 167.

¹² Scherffel, *Archiv f. Protistenk.* xxü, 1911, p. 334.

traced throughout the class, one with a single cilium (Chromulinales), another with two equal cilia (Hymenomonadales), and a third with two unequal cilia (Ochromonadales). Each series is represented by motile unicells (e.g. *Chromulina*, *Ochromonas*), by motile colonial types (*Synura*, *Uroglena*, &c.) parallel with the Volvocales among Isokontae, and by an extensive development of sedentary epiphytic forms peculiar to the class and provided with a wide offstanding envelope. The palmelloid type is also well represented, reaching an exceptionally high differentiation in *Hydrurus*, while the dendroid colony is here realised by the planktonic *Dinobryon*. All of these forms are Flagellates, but within the last dozen years quite a considerable number of algal members of this class have been discovered on the continent, and it is clear that the Chrysomonadales too have progressed in the same direction as Isokontae and Heterokontae, but that here the bulk of the forms have remained flagellate and the minority have become algal.

The latter are represented in the first place by chlorococcoid types like *Chryso-sphaera*,¹³ whose spherical cells contain two parietal yellowish-brown chromatophores, harbour masses of leucosin, and are invested by a firm cell-wall; they reproduce by division of the protoplast with the formation of two new individuals and by means of zoospores closely resembling a *Chromulina*. There are also a considerable number of filamentous forms, such as the unbranched *Nematochrysis*¹⁴ and the branched *Thallochrysis*,¹⁵ reproducing by zoospores resembling an *Ochromonas* and *Chromulina* respectively. Here also, according to the most recent investigations,¹⁶ we must refer Lagerheim's *Phaeothamnion*, whose systematic position was long doubtful. In Hansgirg's *Phaeodermatium*,¹⁷ not uncommon attached to stones in cold streams of Central Europe, we have a discoid type parallel with similar forms in other classes. It is not improbable that each of the three series of motile forms previously mentioned has progressed towards the filamentous stage, although at present only representatives of two of them are known. That the balance in the Chrysophyceae is overweighted on the side of the presumably more primitive flagellate types coincides with the fact that sexuality has as yet been very rarely recorded in members of this class, and is only known to be isogamous. The Chrysophyceae exhibit other special developments in the direction of the Rhizopoda, which are of great interest, but lack of time renders their consideration impossible. Of the great diversity of Chrysophyceae, now known from many parts of the continent, only relatively few have so far been observed in this country, and there is a wide field for research in this respect.

The Chrysophyceae show that in an otherwise rather homogeneous class the type of ciliation may be somewhat variable. Some species of *Ochromonas* are very similar to species of *Chromulina* except for this one feature, and the Chromulinales may well have originated from forms of the *Ochromonas*-type by suppression of the second shorter cilium. Only

¹³ Pascher, *Archiv f. Protistenk.* lii, 1925, p. 533.

¹⁴ Pascher, *loc. cit.* p. 511.

¹⁵ Conrad, *Bull. Sci. Acad. Roy. Belgique*, 1920, p. 180.

¹⁶ Pascher, *loc. cit.* p. 498.

¹⁷ Pascher, *loc. cit.* p. 517.

one cilium has so far been recognised in quite a number of the Heterokontae, and here too a suppression of the second is possible.

Variation in number of cilia is also a feature in the Isokontae, where the dikontan and tetrakontan types are traceable throughout the class, and quite recently a uniciliate member (*Chloroceras*) has been described by Schiller¹⁸; this form is particularly interesting because occasional rare individuals show two cilia. Among the Polyblepharidaceae organisms are known with up to eight cilia which presumably result from multiplication. These facts demonstrate the risk of basing a separate class, Stephanokontae, on the occurrence in the Oedogoniales of swimmers with numerous cilia. Moreover, they show that, although ciliary characters are of undoubted value in the distinction of the main classes of Algae, the point must not be stretched too far and must be supported by other features.

The parallel development, evident in Isokontae, Heterokontae, and Chrysophyceae, is recognisable, though not quite so markedly, also in other classes of Protophyta. One further striking instance may be mentioned. The Peridinieae (Dinoflagellata) are a very distinct and rather specialised class of motile forms, abundant in freshwater and marine plankton, though on the whole more strongly represented in the sea. Their most striking characteristic lies in the division of the body of the cell into two usually slightly unequal, apical and antapical, halves by a transverse furrow harbouring one cilium, while the other trails out behind into the water. There are usually numerous discoid chromatophores which are commonly dark yellow or brown; a number of special pigments (peridinin, chlorophyllin, &c.) have been extracted from them. The reserves are stored as starch and oil. The nucleus is usually large and conspicuous, and shows either a granular structure or contains numerous fine threads.

It was in 1912 that Klebs¹⁹ described a number of forms that were clearly algal and chlorococcoid members of this class. His *Hypnodinium* shows the derivation clearly; it consists of large motionless spherical cells provided with a firm membrane and possessed of the chromatophores and nuclei characteristic of the class. When reproduction takes place, the protoplast contracts somewhat and develops the distinctive furrows, but this is followed by division without resort to a motile phase. The two daughter-cells show no traces of furrows until a fresh division is initiated. In *Phytodinium* no such furrow-formation is observed and with it the last indication of the motile phase has disappeared. It is of interest that, among these chlorococcoid Peridinieae, Klebs distinguished one tetrahedral form (*Tetradinium*) recalling in outward shape the genus *Tetraëdron* among the Isokontae and *Pseudotetraëdron* among the Heterokontae. In 1914 Pascher²⁰ briefly described a slightly branched filamentous Alga, *Dinohrix*, which is stated to have the discoid yellow-brown chromatophores and the large nucleus of the Peridinieae and to reproduce by swimmers resembling a *Gymnodinium*, one of the simplest of the motile types. Unfortunately no further description or figure of

¹⁸ *Österr. Bot. Zeitschr.* lxxvi, 1927, p. 1.

¹⁹ *Verhandl. Nat.-Med. Ver. Heidelberg*, xi, 1912, p. 369.

²⁰ *Ber. Deutsch. Bot. Ges.* xxxii, 1914, p. 160.

this form has so far been forthcoming. There is no doubt, however, that in the Peridinieae there have again been diverse 'algal developments,' although the main differentiation of the class centres around the motile unicell.

As an antithesis to classes like the Chrysophyceae and Dinophyceae (as Pascher has styled the whole series of Peridinian forms) we have the Myxophyceae (Cyanophyceae), where motile types are altogether unknown and all the forms exhibit an algal organisation, progressing from the unicellular through the colonial to filamentous types. Even in this very sharply circumscribed class a considerable degree of parallel with those previously considered can be recognised. Other distinct classes of Protophyta exhibiting holophytic nutrition, but of more restricted range and generally showing special development in one direction or another, are the Bacillariales (Diatoms), the Cryptophyceae (including the flagellate Cryptomonadineae and a few little known algal types), the Chloromonadineae, and the Euglenineae. A detailed consideration of these is unnecessary, but in all of them one or other organism can be recognised as parallel with types in the classes that have been previously discussed, although none has evolved the branched filamentous habit so far as at present known. As instances of parallelism one may cite the occurrence of the dendroid colony in the Diatom *Gomphonema* and in *Colacium* among Euglenineae. In the latter class, too, we have the widespread genus *Trachelomonas* in which the motile cell is surrounded by a special rigid envelope separated from the cell proper by a space. This encapsuled type is paralleled in the Isokontae by *Coccomonas* and in the Chrysophyceae by *Chrysococcus*.

To sum up it seems clear that in all the nine classes mentioned evolution has progressed along similar lines and in many cases has led to the production of analogous forms of plant-body. Thus, the motile unicellular individual, the motile colony, the palmelloid type, the dendroid colony, the chlorococcoid type, the simple and the branched filament, the siphonous type, and others are all to be found in two or more of these classes. In five of them, moreover, the stage of the branched filament has been reached.

While occasional indications of relationship are to be found (e.g. between Heterokontae, Chrysophyceae, and Bacillariales),²¹ they are not very marked, and it is probable that all the nine classes represent as many evolutionary series of uncertain origin. We have in them practically all that is left to us of the early evolution of the holophytic organism. It can scarcely be doubted that there were other phyla which have become extinct, nor is it likely that future research will fail to disclose further series than those at present distinguished.

The Relation of the Protophyta to the Higher Plants.

It has been suggested in certain quarters²² that the simple freshwater Algae are reduced from forms which had a more elaborate parenchymatous soma, being in fact 'starvation-forms' resulting from a paucity of nutritive salts. It should be stated in the first place that, although

²¹ Pascher, *Ber. Deutsch. Bot. Ges.* xxxix, 1921, p. 236.

²² Church, *Oxford Bot. Memoirs*, No. 3, 1919, pp. 8, 46.

reduction-series can be recognised in some groups of the Algae, there is no evidence at all to indicate that freshwater Algae as a whole have undergone reduction. It must be remembered too that a large number of similar un specialised forms are found in the sea. Moreover, with the facts of parallel development before one the supposition of a general reduction becomes practically untenable. We have no knowledge of any forms from which the filamentous Heterokontae or Chrysophyceae, for instance, could be derived by reduction, for the relationship between Chrysophyceae and Brown Seaweeds formerly entertained is probably fallacious and now no longer credited by most authorities. Until some real evidence can be adduced that reduction has occurred, it appears more logical to regard the filamentous forms in the different classes as the end-points of an upgrade development. Further facts that lend support to such an interpretation are the wide distribution of the simpler, less specialised, members of each class (very noticeable in the case of many groups of the Isokontae), while the more highly specialised forms are commonly of more restricted distribution. Within the Isokontae too anisogamy or oogamy are associated with the advanced forms and are mainly a feature of the specialised filamentous types, a fact which supports the idea of a progression, rather than of a retrogression. In other classes also sexuality is usually found only in those forms which have the more elaborate organisation.

Among the numerous septate filamentous Isokontae, it is possible to distinguish four separate series, of which the Oedogoniales and Conjugatae have already been recognised as specialised along directions of their own. Of the other two, the Ulotrichales are the simpler and the Chaetophorales the more complex, both possibly originating from a common stock. Many authorities, in fact, fail to distinguish these two groups, but the organisation of the Chaetophorales is so distinct from that of the Ulotrichales that, from the standpoint of comparative morphology, their separation is desirable. Whereas in the Ulotrichales we have a simple or branched filament attached by a more or less elaborate basal cell, the central types among Chaetophorales are distinguished by the possession of a plant-body showing differentiation into a prostrate system of creeping threads serving *inter alia* for attachment to the substratum and a projecting system which is more or less richly branched. This differentiation is seen for instance in many species of *Stigeoclonium*, *Coleochaete*, and *Trentepohlia*, representing three distinct families and three distinct developmental lines within this group. Among its numerous members there is much variation in the relative differentiation of the creeping and projecting systems, and reduction of the latter has led to a whole series of specialised prostrate or discoid types (*Aphanochaete*, *Protoderma*, &c.). It is to be noted, too, that the Chaetophorales exhibit a greater morphological diversity and a capacity for existence under more varied circumstances than any other group of Isokontae, and in the Trentepohliaceae include one of the most vigorous and highly differentiated families of terrestrial Algae.

The type of construction just considered is not encountered in any of the other nine classes of Protophyta previously mentioned, although hinted at in the Chrysophyceae and some Myxophyceae. An analogous differentiation of the filamentous thallus into a creeping and a projecting

system is, however, characteristic of many Ectocarpales (e.g. *Ectocarpus*) and Nemalionales (e.g. *Chantransia*), which include the simplest known members of the Phaeophyceae and Rhodophyceae respectively. In fact it appears that this kind of plant-body represents a definite stage in the evolution of various classes of Protophyta, affording another instance of parallelism. But, whereas in the Isokontae it represents the most advanced type of which we have any knowledge, in the two great marine groups it is seen in the simplest of the present-day forms, since no unicellular or palmelloid members of these classes are certainly known to exist. A consideration of the metabolism and reproductive features of the two groups of Seaweeds, however, clearly supports an origin for each of them distinct from that of any of the classes previously mentioned.

It will be familiar that, of all the holophytic Protophyta, the two classes Phaeophyceae and Rhodophyceae, which are almost confined to the sea, have alone attained to a high degree of morphological and anatomical specialisation, often affording in one feature or another marked instances of parallel with those groups of the Vegetable Kingdom which are now dominant on the land. We owe to Church²³ a clear statement of these points of parallel and a suggestion that many, if not all, the fundamental features of higher land-plants were already realised in a marine environment before a terrestrial flora was evolved. The totally differing metabolism obviously renders impossible, however, any direct derivation of the land-flora from forms belonging to either class of marine Algae.

It will be generally agreed that we must seek the origin of terrestrial plants in organisms possessing the same plastid-pigments and the same essential metabolism as they do. The only representatives of such forms among Protophyta at the present day are afforded by the numerous Green Algae, the Isokontae. These, however, as has previously been pointed out, stop short at a level of morphological differentiation of the thallus, at which the two marine groups commence. Roughly speaking, too, the stature of the most highly differentiated Isokontae is approximately equivalent to that of the simpler Brown and Red Algae. Yet, in sexual differentiation and specialisation of the reproductive machinery, there is little to choose between these three classes, although the Red Algae have in part developed post-fertilisation complexities peculiar to themselves.

We are thus confronted with the situation that in the Isokontae we have a class of great morphological diversity in which almost every conceivable type of simple plant-body has been realised and is still existent at the present day, but which stops short at a massive parenchymatous construction and forms of large stature. In the Brown and Red Algae, on the other hand, where no simple forms of plant-body are certainly known, plants of large size and possessed of a highly developed parenchymatous soma are abundantly represented. It appears improbable that a class like the Isokontae, showing such extreme capacity for morphological elaboration in every direction and for adaptation to very diverse habitats, should have failed to develop further in the direction generally indicated by Phaeophyceae and Rhodophyceae. Moreover, it must be remembered that they possess

²³ *Op. cit.*

the photosynthetic equipment which has evidently proved to be the only successful one on the land, and that practically every group and family of Isokontae has its terrestrial representatives.

What then, it may be asked, has become of the more highly elaborated members of this class? It seems to me that there is every reason to suppose that, approximately at the level of morphological differentiation and stature reached by the Isokontae of the present day, the terrestrial habit was adopted in the remote past, that the more highly elaborated Green Alga became a land-plant, the early forms of which are perhaps yet to be disclosed by palaeontological research. The facts of relative development of the three large algal classes just considered appear to indicate that the first land-plants were probably forms of small stature, although not necessarily quite as simple as the most advanced Isokontae known to us at the present day. In this connection it is not without significance that the oogamous members of this class for the most part occupy a peculiarly isolated position, appearing as outliers well in advance of the rest, although for none of them is there to my thinking any possible connection with the higher land-plants. On the little available evidence it seems possible that oogamy may have been undeveloped or in an incipient stage in the first land-plants.

If one recognises among Phaeophyceae and Rhodophyceae many features of anatomy, life-history, &c., that recall the characteristics of land-plants, I can see in that only a confirmation of the belief that environment has little to do with the broad evolution of the plant-organism and that these features are a natural outcome of the evolutionary trend in the Vegetable Kingdom and not any positive evidence for the view that they must necessarily have originated in a marine environment. The comparative study of the simpler forms of plant-body in the different classes of Protophyta lends great support to such a concept of a general evolutionary trend. Before we adopt the idea of a mythical group of Thalassiophyta as ancestral to the land-flora, the blind termination of the Isokontae must be accounted for. A more intensive investigation of the Chaetophorales, and in particular of the terrestrial Trentepohliaceae, than has hitherto been undertaken may well afford data bearing upon the relation of the Isokontae to higher plants.

It is scarcely possible to touch on the problem of the origin of the latter without some reference to that striking universal phenomenon in the life-history of the land-plant, the two alternating generations. It is just in this respect that the Isokontae are too incompletely known to afford any good points of contact. We know now, thanks to Dr. Knight's researches on *Pylaiella*, that an homologous alternation exists in this simple filamentous Brown Alga, and it is possible that analogous cases are yet to be discovered in the Chaetophorales among Isokontae. In this connection attention may be drawn to certain observations made by Meyer²⁴ on *Trentepohlia umbrina* which appear to indicate a segregation of sporangia and gametangia on distinct individuals, and other like cases are suspected. These merit a fuller investigation. As a matter of fact, except in a few special instances, the cytological features of the life-cycles

²⁴ *Bot. Zeit.* lxxvii, 1909, Abt. 1, p. 26.

of the filamentous Green Algae are practically unknown, and a reinvestigation of *Coleochaete* (and especially of other species than *C. scutata*) from this point of view is advisable. Lambert in 1910 reaffirmed²⁵ the presence in the life-cycle of *Coleochaete* of a succession of small plants that are purely asexual, a feature already emphasised by Pringsheim.²⁶

Klebs' classical investigations²⁷ on the conditions of reproduction in various Algae have generally been regarded as disposing of the possibility of any alternation between asexual and sexual filaments such as Pringsheim postulated, but on closer consideration they afford no absolute proof of its non-existence. In the usual dense tangle of filaments asexual and sexual individuals may easily be intermingled, either remaining purely vegetative until conditions suitable for the formation of reproductive cells are realised. But there are more important considerations than these. With reference to *Ulothrix zonata* Klebs²⁸ especially remarks that it always depended on chance whether he was able to get threads to form gametes or not.²⁹ He also records how at one and the same time threads from one habitat readily formed gametes, while those from another failed to do so. And *Ulothrix* is the only member of Ulotrichales and Chaetophorales in which Klebs deals at all fully with the sexual reproductive process. Yet from this one case conclusions have been drawn for the whole group!

There is, so far as I can see, little positive evidence that asexual and sexual reproduction takes place at all frequently in one and the same filament of these forms, although there is no reason why sexual individuals should not reproduce themselves asexually after the manner of *Pylaiella*. An important matter for investigation is: are there in these filamentous Green Algae threads that can only reproduce asexually and that by no manner of means can be brought to sexual reproduction? This may be more readily established than possible cytological differences, which call for a highly skilled investigator owing to the small size of the nuclei in most of these forms. The fact that in so many Ulotrichales and Chaetophorales the zoospores have four, and the gametes two cilia, is perhaps significant from this point of view.

Even if, however, further investigation should altogether support the present view that there is no alternation between asexual and sexual filaments in the Green Algae, the example afforded by *Pylaiella* serves to show how easily alternation can arise in lowly filamentous types, and in the case of terrestrial plants it may have originated after, rather than before, the adoption of the land-habit. I have elsewhere³⁰ indicated how the dual development of the plant-body in types like the Chaetophorales might readily, in the course of further evolution, afford an upright sporophyte and a prostrate gametophyte. I have nothing to add to this and I do not propose to pursue the topic further.

²⁵ Tufts Coll. Stud., *Scient. Ser.* iii, 1910, p. 61.

²⁶ *Gesammelte Abhandl.* i, 1895, p. 305 (*Jahrb. wiss. Bot.* ii, 1858).

²⁷ *Beding. d. Fortpflanzung*, Jena, 1896.

²⁸ *Op. cit.*, p. 314.

²⁹ *cf. also* Dodel, *Jahrb. wiss. Bot.* x, 1876, p. 539.

³⁰ *New Phytol.* xv, 1916, p. 233.

The Investigation of Freshwater Algae.

The many new freshwater Algae that have become known in the present century and that have contributed so largely to the foundation of the concept of a parallel evolution in the different classes, show how much a study of these forms may still be hoped to reveal. And at present the field of research is restricted to quite a small area of the surface of the globe. Over great parts of the earth the investigation of these forms is only just commencing, and enormous tracts are still altogether unexplored from this point of view, so that it is impossible to say what is yet to come to light. Already in many families of Isokontae it would seem that almost every conceivable variant of the central type has been evolved, and there can be little doubt that the parallelism with which I have dealt in the earlier part of this address will become still more striking, as investigation proceeds and some of the present gaps become filled up. I propose therefore to devote the little remaining time to a few words upon the methods of algal investigation.

The position of England as the centre of a huge empire is responsible for the fact that its few algal workers are inundated with demands for the working out of collections made in its dominions and colonies. G. S. West and his father devoted much time to such work which is very laborious, and I have myself fallen a victim to it. It cannot, however, be sufficiently emphasised that Algae are far better examined in the fresh condition, for however well preserved, in these simple forms where details of cell-structure are all important, much is obscured or becomes unintelligible. It is greatly to be desired that competent botanists should take up freshwater algal investigation in different parts of the empire, and the activities of a number of Indian workers in this direction is a matter for congratulation. The necessary literature is now available in a fairly condensed form, and willing assistance will always be furnished by those in this country.

Moreover, an Alga cannot be said to be properly known until it has been studied at frequent intervals and, if widely distributed, examined in its diverse habitats. In this respect almost everything still remains to be done, even in our own parts of the world. Our cognisance of algal genera and species is still very limited, because they have been mainly studied on the basis of casual collections. True, in many cases (as for example in Oedogoniales and Conjugatae) there are such decided reproductive or vegetative characteristics that species can be broadly distinguished without a full knowledge of their complete range; types with the same essential characteristics at least recur frequently in different habitats and in different parts of the world. But there are many groups and genera, where no such decided characteristics exist, or where possibly they still remain to be discovered, and where every algal worker has again and again experienced the difficulty of a satisfactory determination; this is true, for example, of the majority of the Ulotrichales and Chaetophorales, not to speak of the many difficult genera of Chlorococcales and Myxophyceae. In all such cases we shall never arrive at a satisfactory solution of the problem until a careful study has been made of the range of variation of at least the commoner forms, not only in the course of

their annual cycle but in different habitats. The former is in a sense more important than the latter, since habitat-forms may be expected to represent distinct entities that in their respective environments will often maintain constant differences. Brand's study of the *Cladophoras*³¹ has, however, shown how much an algal species can vary in the different seasons of the year, and analogous studies of species of genera like *Ulothrix*, *Stigeoclonium*, *Trentepohlia*, &c., are urgently required. They will not only lead to some solution of the 'species' difficulty, but may as already indicated afford valuable data in connection with possible points of contact with higher plants. Moreover, they are readily compassed during periodicity studies, such as have already afforded much information as to the conditions determining appearance, abundance, and reproduction of diverse Algae.

An attempt has been made in various quarters to find a solution of the species problem in the method of 'pure culture.' It is well, however, to realise the limitations of the method, and it may be doubted whether, except from the standpoint of physiology, the large amount of labour that has been expended on such work has been justified. Two monographs of the genus *Scenedesmus* based on pure cultures have appeared in recent years, but the authors do not agree in any way as regards the limits of the species. It cannot be denied that, as a supplement to frequent direct observation, pure cultures may be of considerable value and that under certain circumstances (e.g. in the study of subterranean soil-Algae or of endophytes) they are essential. The conditions are, however, for the majority of Algae so artificial and of necessity in certain respects so uniform as compared with those in nature, that the results obtained require to be interpreted with great caution.

Indoor conditions, especially in laboratories, are already as a general rule sufficiently harmful to freshwater Algae, and the occurrence of various bizarre forms in agar-agar or gelatine cultures, while of some interest from the point of view of comparative morphology, cannot be regarded as proving that such forms belong to the normal cycle in nature of the Alga in question. Conversely because, in a pure culture, a given Alga varies only between very narrow limits, that is no proof that these represent the full range of its morphological variation, but merely that under the peculiar circumstances of a pure culture it exhibits this 'habitat-form.' No systematist would be satisfied with a knowledge of a higher plant derived only from specimens grown in a botanic garden, where conditions are by no means as artificial as they often are in an algal culture.

I have offered these comments on the study of Algae in pure cultures, not with any wish to deny the utility of the method in certain directions, but in order to make clear that it can in no way replace direct observation of the Alga in nature. Here alone we have the natural form, subjected to the normal seasonal changes and other meteorological influences, holding its own in competition with the other living members of its environment, and exposed to the influence of the frequent changes in the organic and inorganic content of the water. It is a mistake to suppose that careful periodic observations cannot in most cases lead to the desired goal. The work will be laborious, but the labour will be repaid by the

³¹ *Bot. Centralbl.* lxxix, 1899, p. 145.

results. Immersion of glass slides or cover-glasses in the water will often afford valuable comparative data on the early stages of development.

Since a large number of botanists are professionally occupied in towns, such direct observation of Algae is a matter of some difficulty and in some cases of impossibility. Under these circumstances work with algal cultures is easiest, and this has no doubt been a factor in its rather widespread adoption. It is a matter of regret that practically no facilities exist in this country for the direct study of freshwater Algae and of the many limnological problems that are linked up with it. There are no freshwater biological stations, so far as I am aware, apart from the Experimental Station at Alresford, Hants, of the Ministry of Agriculture and Fisheries. Nor have there been many researches in this country dealing with the biology and ecology of freshwater Algae, although thanks to the Wests and to Dr. Pearsall some very valuable work has been done on the waters of the Lake District; Dr. Griffiths, too, despite the difficulties, has made considerable progress with the study of the freshwater phytoplankton of the lowlands.

It is specially to be deplored that there is no biological station with a permanent staff on the Norfolk Broads, where many problems of general interest could be attacked, and which would be within fairly easy reach of many of our universities. The benefits likely to accrue from the pursuit of investigations at such a station would by no means be confined to the pure aspects of our science, since the study of freshwater Algae is fundamental for the understanding of the general biological features of a piece of water and is intimately related to its productivity in animal life, including the diverse kinds of freshwater fish. Much profitable and important research in this direction emanates from Sweden, Germany, and other European countries, nearly all of which possess several well-equipped and well-staffed freshwater stations, but to this we, as a country with a large area of freshwaters, contribute practically nothing.

THE BROADENING OF THE OUTLOOK IN EDUCATION.

ADDRESS BY

THE DUCHESS OF ATHOLL, D.B.E., M.P., D.C.L., LL.D.,
F.R.C.M.,

PRESIDENT OF THE SECTION.

I FEEL as if I owed this assembly an apology for speaking on a theme which to many may seem well-worn. If I cannot claim any novelty for my subject, neither can I pretend to any expert or first-hand knowledge of the work of the schools. But perhaps you will allow one whose experience of education has been limited to the administrative side to indicate one or two conclusions to which that experience has led. A further reason for my choice of this subject is its intimate connexion with what is generally recognised as the main educational problem of the day—the education of the adolescent. It is because I think we all feel how important a bearing this question has on our social and economic well-being that I venture to bring the subject before you.

The Board of Education's Consultative Committee, in their recent Report on the Education of the Adolescent, have made various recommendations, of which the one that seems to have attracted most attention is that which deals with the raising of the school age to fifteen, as from the year 1932. Important as that question is, important as is the further recommendation that, a great extension of post-primary instruction being desirable, such instruction should be given under a unified scheme of administration, the heart and kernel of the Committee's proposals lies in their recognition of what I conceive to be a fact of fundamental importance—that in a large number of children wide variations of capacity and gifts are to be expected, and that courses of instruction must therefore be varied to suit. 'Equality,' they declare, 'is not identity, and the larger the number of children to be provided for, the more essential it becomes that they should not be pressed into a single mould.' The child of practical ability must be catered for as well as the child of literary or scientific gifts.

These statements may well appear too obvious to need argument. From the day when education began to aim at developing faculties as well as disciplining them, the case for a varied curriculum became overwhelming. If moral and perhaps intellectual discipline may be acquired through the study of uncongenial subjects, intellectual development can surely only come with understanding, or when an appeal is made to some latent faculty for appreciation or creation. A child to whom the use of words is new must have those words related to things seen and realised

in his own experience, or they will be meaningless; once grasped, they awake his reasoning faculties. An appeal, therefore, to a love of colour, or of animals, or to a child's creative instinct, will equally lay the foundations of cultural development. Anything in human or natural creation that arouses interest, that awakes a response, any spark that, in Browning's words, 'disturbs our clod,' must be an agent, and a powerful one, in the great process which we call education.

It would be ungrateful to the many reformers of the past not to recognise how extensive has already been the widening of the curriculum both in school and university. The history of education may indeed be said to be the story of the broadening of the outlook. We have travelled long and far since the cathedral schools of the Middle Ages in which, the purpose being to train boys for the Church's service, whether as choristers or clergy, the instruction was confined to Latin, the language of the Church. Universities, when founded, marked a slight extension of function, inasmuch as they trained men not only for the Church but for medicine and the law. But, as Professor Adamson points out, in the age of chivalry the education of both school and university was felt to be unfitted for the boy who was destined for the more active life of a soldier or an administrator of landed estates, and he received training on entirely different lines, lines that in some respects appear to us to-day as more truly cultural, if somewhat superficial. The Renaissance added Greek to the curriculum of our universities—though do not let us forget that the direct intervention of Henry VIII. was necessary to secure its admission to Oxford—and the 'New Learning' of that time gave a more humanistic outlook to all classical study, but many centuries were to pass before the other studies necessary to a well-balanced curriculum won their rightful place in school or university.

France, from the sixteenth century onwards, had her 'academies' in which modern languages, mathematics and some science were added to the study of the classics. Locke, as early as the end of the seventeenth century, took another long step forward, and stressed the value of manual instruction. He urged that it should form part of the education of everyone who followed what he termed a 'gentleman's calling,' and pointed out the advantage of handwork as a recreation for 'one whose chief business is with books and study.' Rousseau and Pestalozzi alike denounced the prevailing 'bookishness' of the education of their days; Pestalozzi in particular, as we know, laying great emphasis on the value of handwork. English public schools and grammar schools, however, remained dominated by the purely classical tradition until the nineteenth century was far advanced, though the industrial revolution gradually brought into being private schools, with a modern and commercial bias, but for the most part superficial in their work. Such schools were frequented by the sons of manufacturers who regarded the classical curriculum as an unsuitable preparation for a business career. 'Academies' on fairly modern lines were opened in Scotland from the middle of the eighteenth century, but so great was the prestige of the old classical tradition in North as well as South that the Scottish 'academy' often ended by becoming the grammar school on a slightly more modern basis. Mr. Fearon, however, reporting in 1866 to the Schools Inquiry Commission on the principal

'burgh' schools of Scotland, points out that the dependence of these schools on fees and support from public funds tended to make their curriculum broader than that of the English endowed schools, which was too often limited by the wording of trust deeds.

Thring introduced manual work and music into Uppingham in the middle of the nineteenth century, but until mathematics, science, modern languages, and English had won a recognised place in the curriculum, only a limited development could be expected of subjects still further removed from the tradition of the schools.

It may be said that it is only within the last twenty or thirty years that we have succeeded in establishing a fairly balanced secondary curriculum on academic lines. The claims of English, indeed, in secondary schools are hardly yet fully established, and the cultural value of music is only slowly gaining recognition. We are no longer ready to accept the dictum of William of Wykeham that grammar (i.e. Latin) is 'the foundation gate and origin of all other liberal arts, without which arts of this kind cannot be known,' but are we not too ready to give our assent to the view that the study of a foreign language is necessary to culture? It is well to remember that the Committee on the Teaching of Modern Languages expressed the opinion that 'in schools where the majority of pupils do not stay for more than four years it may be advantageous that, after due trial, a certain proportion should be entirely relieved of language study and should concentrate their attention on English and the various other subjects which cannot be neglected in such schools. A pupil may have very useful abilities and yet be incapable of learning any foreign language. In the curriculum of such pupils the study of English might be much more fully developed than it is at present.' It may be added that for these pupils the study of good translations of the best foreign literature, both ancient and modern, should greatly assist the attainment of a broad culture.

Such being the history of the literary and scientific subjects, we need not be surprised that the progress of handwork has been slow. From 1889 onwards, Local Authorities were empowered to give technical instruction, and a generous provision of public money was made for the purpose, but the instruction provided was frequently on too narrow and specialised a basis to have great educational value and therefore lacked popularity. Until the Education Act of 1902 enabled Local Authorities to deal with secondary as well as technical education effective co-ordination of the two was impossible.

It was not, however, until seven years after the passing of the Act that the Consultative Committee were asked by the Board of Education to consider the extent to which education by means of practical work should be developed in secondary schools. In 1912 the Committee reported to the effect that secondary education had been too exclusively concerned with the cultivation of the mind by books and the instruction of the teacher, and recommended that every secondary school should provide for the teaching of some branch of educational handwork. Handwork to-day, therefore, is found in some degree in all secondary schools in England and Wales, but, as the Consultative Committee pointed out, pressure of work often leaves little time for it in the forms preparing

for external examinations. About 1915 a further step was taken, when an alternative course of a practical character was introduced into a boys' grammar school in the West Riding of Yorkshire. The experiment was found so successful in creating fresh interest, and in its reactions on other studies, that it was extended to other schools in the same area. Similar experiments existing to-day elsewhere could be mentioned. It is interesting to find that, in 1926, the Association of County Councils, in giving evidence before the Consultative Committee, advocated the institution of alternative courses in secondary schools. Whether the alternatives should be within the walls of one school or of two seems a point of minor importance from the educational aspect, though it raises important administrative questions. The main desideratum is that wherever there is a secondary school of the usual type, simpler and more practical alternatives should also be available in order that the needs of children of varying types of ability may be met. We must, in fact, begin with the child and make the curriculum suit him. The converse policy has held the field too long in spite of its obvious absurdity.

Even before the passing of the 1902 Act some of the larger School Boards had established higher grade schools, many of which provided manual instruction—a clear indication of the need felt in many quarters for a post-primary school of a more practical type than the purely secondary. In 1895 the Bryce Committee had reported favourably on schools of this kind, pointing out that they corresponded to the third grade of secondary school advocated by the Schools Inquiry Commission in 1868, and recording their opinion that secondary education included technical as well as academic subjects. In 1905 the Board's Consultative Committee also expressed themselves strongly in favour of schools which would combine a general education with some practical instruction in a course extending up to fifteen years of age. But though grant was allowed for higher elementary schools under a minute of 1905, the more immediate necessity was felt to be the development of the secondary school of a purely academic type, with a normal leaving age of not less than sixteen.

By 1911, however, the London County Council had taken the initiative in developing the type of school known as 'central,' aiming at a combination of practical instruction and general culture in a four-years' course from eleven to fifteen. The setting up of similar schools followed in other areas in England and in Wales; and in 1918 the Education Act made it obligatory on Education Authorities to provide 'practical and advanced' instruction either in central schools and central classes, or otherwise.

The Scottish Education Act of that year contained no such provision, but Scotland for some years had had an alternative to 'secondary' education in 'supplementary' courses for children of the age-range of twelve to fourteen, which included practical instruction. In the large centres these were well staffed and equipped, but in rural areas too often both staff and equipment were insufficient, the long survival of the parochial system making it impossible to assemble the older children from various parishes at one centre, as in England. In 1919 the establishment of county Education Authorities brought a great increase of scholars to secondary schools, but too many of these, it was found, left at fourteen and fifteen

without taking any certificate. In 1923, therefore, the Scottish Education Department instituted 'advanced divisions,' as alternatives to the first part of the purely secondary course, but under more exacting conditions of staffing than the old supplementary departments. All courses must have a 'common core' of English subjects—these having the lion's share of the time-table—training in morals and citizenship, mathematics (or, for girls, arithmetic), art and music. At either end of the scale are a number of alternative subjects, academic or practical. A foreign language is not compulsory. A 'higher day school certificate' is to be taken at the end of the course—normally at the age of fifteen. A 'lower day school certificate' is given a year earlier.

While, however, it is obvious from a recital of these facts that some steps have been taken to meet the demand for a wider curriculum, the position as we review it to-day can hardly be considered satisfactory. Too often our aim appears to be to pass on as many children as possible to the ordinary secondary school. Here the curriculum, however admirable an instrument of all-round culture for boys and girls of scholastic ability, if they remain at school until sixteen or later, may be quite unsuited to the boy or girl of another type who will leave school at the age of fourteen or fifteen. Though school life is appreciably lengthening, only one-half of the pupils in secondary schools in England and Wales enter for the first schools examination; only one-third of the pupils pass. Moreover, the Consultative Committee have expressed the opinion that schools or departments of the practical or 'modern' type are needed for the great majority of the children in the country; yet the number of children receiving this type of post-primary instruction, though steadily increasing, is only about one-third of the number in secondary schools. What are the reasons for this comparative failure to supply what I venture to suggest is the most pressing need of our education system as it exists to-day?

One, I think, is to be found in the fact that most persons interested in education have been educated mainly on academic lines, and therefore have found it difficult to realise the need for practical instruction. This, we are told, is why the efforts made many years ago by Sir James Kay-Shuttleworth to increase the practical training in elementary schools met with little success. At a later date the grant system was to blame. 'Payment by results' tended to restrict elementary education to the three R's, and gave a serious set-back to manual training.

Other reasons were the expense of the equipment, the comparative failure of the technical instruction given prior to 1902, the tardy development, outlined above, of the secondary curriculum, and the delay in organising secondary education on a national basis. Matthew Arnold's plea—first uttered in the 'fifties—that secondary education should be organised on a national basis, had fallen on deaf ears. Wales obtained powers for secondary education in 1889, but none were available in England until the Act of 1902. The varying types of higher grade, higher elementary and science schools, which in the years following 1870 were added to the schools of the old grammar school type, may well have made it appear that the first task alike of the Board and of the new authorities set up by the 1902 Act must be to develop a clearly defined

secondary school. In recent years the demand for more secondary schools, the need for dealing with many arrears of improvements or developments left by the war, and the financial difficulties with which Central and Local Authority alike have been beset, have delayed the expansion of practical instruction required by the Fisher Act.

Yet another reason may be given. Secondary schools have had behind them the prestige of the universities, to which their curriculum naturally leads, and central schools in comparison have sometimes been regarded as blind alleys. Universities are the crown of our educational system. It is a laudable aim that the education of all children of scholastic ability should be rounded off there—and, on the other hand, universities of late years have broadened their curriculum to include many technological subjects. But their doors are guarded, and rightly so, by an examination which demands the all-round curriculum of the ordinary secondary school. On the maintenance of an effective entrance test depends to a considerable extent the standard of work of the universities, and on the standard of the universities depends the standard of every school in the country. Do not let us make the mistake of judging the efficiency of our educational system merely by the number of young men and women we send to the universities. Let us judge it rather by the standard of our universities, by the extent to which they are accessible to young people of scholastic ability, irrespective of circumstances, by the adequacy and efficiency of other provision for continued or higher education, and by the extent to which universities and other institutions alike, whole-time or part-time, are ministering to the development of powers of appreciation, thought and varied ability among our people.

Further, I find it difficult to resist the conclusion that our tardy and somewhat grudging recognition of the need for practical instruction has been due partly to a failure to appreciate the psychological issues involved. There are two things which we seem too ready to forget. The first is that not only in the early stages, but also in the later—in adolescence—there will be no intellectual development without interest and understanding. The second is that if a child is not able to take interest in at least some of his lessons, school may be positively harmful to his mental development. ‘An unsuitable course,’ said Sanderson of Oundle, ‘may not only fail to develop, but actually retard progress.’ Yet too many of us, quite unconsciously, seem to be guided by Mr. Dooley’s aphorism that ‘it doesn’t matter what you teach a child so long as he doesn’t want to learn it’!

The value of practical instruction for younger children is now fully admitted, but too often we seem reluctant to recognise what its worth may be higher up in the school. Yet Professor Cyril Burt, to whom I am indebted for some valuable notes on this subject, writes that recent psychological tests have shown that both the range and nature of individual abilities differ increasingly among older children—‘though differences in inborn ability may appear quite early among individual children, the degrees to which they differ become larger and larger, and continue to increase (at any rate up to the age of about fourteen) almost proportionately with increasing age.’ The need for variety of curriculum increases, therefore, with adolescence.

Again, we have been ready to own the worth of practical instruction for the dull and backward, and to understand that one of its special values

may lie in a rapid and desirable increase in self-confidence and self-respect among such children, but we have been slow to grasp the distinction between verbal and non-verbal or practical ability, and to realise how much ability, quite equal to the normal, may fail to show itself in the ordinary lessons of school. We constantly remind ourselves of the many distinguished men who in their school days were held to be of little promise, and yet we hesitate to draw the obvious conclusion that their school life should have been able to do something more to develop their special gifts.

As long ago as 1912 Sanderson of Oundle expressed the opinion that probably the majority of boys thought in things, not words, and described how boys considered dull in class developed intellectually when set to work in shops, laboratories, drawing-office or fields. They gained in self-respect and confidence and returned with good results to subjects which previously had been dropped. Their work in school had a new interest for them, and many such boys had ended by gaining university scholarships.

But Professor Burt goes further still. 'So much of the children's daily work in after-life,' he reminds us, 'will depend upon muscular co-ordination that a training in manual dexterity should form a part of the all-round culture possessed by every human creature. To perfect their accuracy all the muscular mechanisms of the body need specific exercise.'

Manual work, moreover, in its finer form leads to the development of a sixth or 'kinæsthetic' sense, which Sir Charles Sherrington's research has shown to depend on sense-organs embedded in the muscles. On this depends the prowess of the athlete, the highest skill of a masseur or trained mechanic. It probably reaches its greatest perfection in the musician's 'touch.' An organist has this sense developed not only in his hands but in his feet.

Professor Burt is, therefore, I think, right in warning us against the popular and exaggerated antithesis between handwork and brainwork. 'All handwork,' he writes, 'that deserves the name is also brainwork. The reception and appreciation of muscle sensation is as much an intellectual activity as the reception and appreciation of the "higher" sensations that are received by the observing eye or by the listening ear. Handwork, therefore, may claim quite as much "intellectual respectability" as reading, writing or arithmetic.' As the Consultative Committee have done well to remind us, a liberal or humane education is not to be secured through books alone.

Are we not also in some danger of ignoring the importance of purpose in learning? The child is essentially a practical being. His deepest instinct is to create and experiment; his highest ambition to imitate what he sees his elders doing. As adolescence approaches his mind develops new interests and powers that are practical rather than purely intellectual or academic. The sounds of the world reach him through the school doors and lure him with the hope of a life of greater liberty and more definite usefulness. Masters of schools of every type can testify to the number of boys who take a new and living interest in their school work—of whatever kind it may be—from the day that it can be shown to them that it will help to prepare them for their future career. This sense of purpose—this desire to be of use—seems to me one of the finest

instincts to be found in young people. It must be the task of the school to foster it, to direct it to the channels in which it will best bear fruit, and the school in its turn—and in more classrooms than one—will reap the benefit of the new interests aroused.

There is no need to dwell on the æsthetic value of much handwork, especially such as is taught in girls' schools. All indoor handwork bears a relation to the art lesson, and therefore has a definite part to play in the development of culture.

Nor must we forget the importance of practical instruction as an element in character training. It taps fresh sources of energy, brings them under control, and is valuable to neurotic children in giving stability, and to adolescence in preventing overwork. At this stage Professor Burt tells us that more concrete and practical activities even for the supernormal and especially for the bookworm form a wholesome corrective. We know how much juvenile delinquency is due to the overflow of emotional energy and to misapplied manual skill, and how practical activities have proved successful in giving the youthful offender a necessary legitimate outlet for his energies.

It is clear, therefore, on educational grounds that it is at the post-primary stage above all others that we need the greatest variety of courses, and of courses that will include practical instruction.

But educational reasons are reinforced by considerations affecting our social and economic welfare. We can no more afford to forget the need for co-operation between education and industry than to ignore the economic interdependence of the different parts of the Empire. On the one hand, we recognise variety of character and ability as constituting one of the wonders of human nature, and believe that partly owing to our varied racial strain and partly to our love of mental freedom we may claim to possess it to an exceptional degree. On the other hand, we cannot but be conscious of an almost equal need of the country and the Empire in general for service of varied kinds. Only by services of infinite variety demanding every possible exercise of human ingenuity, initiative and industry, can we hope to find employment for our dense and still growing population. In particular we in this country need the greatest possible development in varied ways of productive industry, as the Overseas Dominions need the development of their vast unpeopled territories. Yet even twenty-two years ago the Consultative Committee, in the Report to which I have already referred, hinted that our education inclined to lead boys to desire to be clerks rather than mechanics, and deprecated any encouragement being given to enter a profession already at that date overstocked. In the years that have elapsed the tendency has increased—girls have entered clerical occupations in large numbers, and the crowding in the professions is greater than ever. Possibly this process has been accentuated since the war by industrial depression; but if our productive industries, both rural and urban, are to meet the competition from abroad which now assails them even more fiercely than twenty years ago, they urgently need the best ability of varied kinds. Schools other than those recognised as 'technical' cannot be expected to send out trained workers, nor definitely to prepare boys and girls for life overseas, but schools and departments giving the 'advanced' and practical instruction

required by the Fisher Act will render rare service to the country if they can develop a capacity to handle tools common to a group of occupations, some knowledge of the main principles of our most important industries or of industries peculiar to the locality, a desire to co-operate in their continuance and expansion, the adaptability which will enable a worker if need be to transfer from one occupation to another, and some understanding of the great opportunities which our Overseas Empire offers to the young man or woman of initiative who is trained on practical and realistic lines.

There are some, I know, who feel that the introduction of machinery and the subdivision of labour make it hopeless to expect the factory worker to be interested in his task. Remembering, however, the interest that the average boy is wont to take in the interior economy of clocks and motors, the unwearied delight of the small boy in drawing engines and aeroplanes, I cannot but believe that the great majority of boys could be interested in the machinery of our various industries if they were made to understand its basic principles; and I feel pretty certain that much generous instinct would respond if it were pointed out that the introduction of machinery, though it had deprived the individual worker of the satisfaction of producing a complete article by his own labour, had so cheapened production that millions now could enjoy what in the days of hand labour was procurable only by the few.

The development of repetitive processes, however, has emphasized the need of education for leisure, and, it may be added, has reinforced the argument that the education given should be such as will arouse powers of interest and appreciation. One of the aims of the school must be to instil a love of good literature, music and art, more especially in those whose working hours in after-life may be spent in drab or monotonous surroundings; but do not let us ignore the part that practical activities, such as needlework, carpentering and gardening may play in the enjoyment of leisure, even in the case of men and women to whose daily work it is somewhat akin. Miners, for instance, are notoriously fond of gardening, and it is difficult to imagine an occupation that can better compensate for the limitations under which their work is necessarily carried on.

Another merit of handwork is that it is often co-operative and so teaches the team spirit. That spirit is also being widely inculcated through games and school organisation. Few greater services could be rendered by the schools to industry and to the country generally than that they should teach our young workers to bring with them into factory or office or mine the team spirit learned on the school play-ground or through school life in general.

From these many points of view therefore it seems to me that our policy must inevitably be to develop new forms of post-primary instruction. Here is the opportunity for the 'modern' school. But it must realise its purpose and be true to it; it must not be a mere imitator and rival of the secondary school. The two types must work in closest co-operation; the 'modern' school must, wherever possible, pass on pupils who give evidence of literary or scientific ability; and the two schools to that end must if possible keep a 'common core' of fundamental subjects. If that be done, the fears which have sometimes been expressed that an extension of schools of the 'modern' or 'central' type will damage secondary

schools should be groundless. When the kind of education which I am advocating is available for those whom it suits, the number following the conventional secondary curriculum may be proportionately less, though we have not yet fully met the need for secondary schools in all parts of England and Wales, more especially in the rural areas. But do not let us forget that schools exist for the children, not children for the schools. The duty of the teacher is to ascertain the varying abilities of the children, a process in which the tests devised by psychologists should be of value. The duty of the administrator is to see that, so far as is reasonably possible, every child is given a chance of developing his special ability, as well as of acquiring general culture.

Moreover, once we recognise that variety of gifts as between boy and boy must receive different treatment, we shall no longer hesitate to differentiate so far as may seem desirable between boy and girl. Time was when it was necessary that girls should give proof of their ability to study the more serious subjects hitherto reserved for boys. To-day that claim has been long established. Heads of girls' schools can now afford to adapt their curricula more than formerly to the varying needs of their pupils, intellectual and physical. More especially does it seem desirable that, unless preparation for professional life makes it impossible without overstrain, time should be found for definite training in domestic science. Many new and wider interests are opening up, but home-making must still play an important part in the lives of the vast majority of women.

I have perhaps spoken of the 'central' school as if it offered us the type of school we want. But its development is recent and it is still in the process of evolution, so that the term may connote either a school giving a purely general course, or one with a commercial or an industrial bias, or both. The London County Council, finding that 'central' schools of the commercial type have tended to increase more rapidly than those with an industrial bias, have lately decided that where possible both courses shall be included in one school—a step which seems eminently reasonable, though the practical difficulties of providing a double bias in one school may no doubt be serious. A head master of long experience in a 'central' school has told me that he found further subdivision of these courses necessary in order to secure interest and sense of purpose. His experience showed that the interest aroused by wider variation had more than made up for the lack of special teachers for each group, and, as elsewhere in such schools, had had marked results in lengthening school life.

As the Consultative Committee emphasize, however, whether 'central' or 'modern' schools realise the desired end must mainly depend on the breadth of vision of head master or mistress, and we may add, of the staff in general. Every keen teacher must long to see his pupils interested in the things which appeal to him personally, and to such it may be a considerable mental effort to realise that the interests of some pupils may develop along quite different lines. As we have seen, the inability of educationists generally to realise this has been one of the reasons for the loss of precious time. But a clear lead has lately been given from the presidential chairs both of the National Union of Teachers and of the Association of Education Committees, and we may therefore hope for a general broadening of the outlook among educationists in general.

And what of the parents? Will they, where advisable, accept the simpler and more practical alternative to the usual secondary course? Here we may find a difficulty due to the prestige of the secondary school. But we must have faith in the influence on fathers and mothers of a sane and informed public opinion, if that can be developed; and if teachers in particular will show their belief in this type of curriculum, many parents, I am certain, will be guided by them. As to public opinion, in the political sphere the auguries are favourable. Unionists at the last General Election pledged themselves to the development of 'central' schools and other forms of post-elementary instruction, as well as to the provision of an adequate supply of secondary schools, and this has been the policy pursued since 1924. The Labour Party have published a statement of their policy in which they demand secondary education of a less 'bookish' type than at present, and no one has stated the case I have endeavoured to put with greater emphasis or clarity than Mr. Philip Snowden; while a recent conference of the National Liberal Federation has declared in favour of the provision of such a variety of schools as will secure the full development of ability of brain and hand alike. Political parties are therefore agreed on this all-important matter.

Nor must we imagine that only in these islands is the need for variety of post-primary curricula felt. The United States found alternative courses necessary by the time that seven or eight per thousand of their population had been received into secondary schools; and a feature of the recent Imperial Education Conference was the recognition from many varying parts of the Empire of the urgent need for bringing the schools into closer relation with reality, and of the cultural value of practical training. The provision of the necessary instruction on the scale required will take time; handicraft teachers are all too scarce; many buildings may have to be enlarged; practical equipment is costly; further experience is needed in the evolution of the curriculum. But if we can keep the principle of variety clearly in view, and can frankly recognise practical work as forming part and parcel of a liberal education, our progress will be sure, even if financial difficulties for a time may oblige it to be slow; and if we can make clear to the country as a whole that we are being guided by these principles, we shall, I am certain, rally to our support much opinion which at present is uninterested or sceptical, we shall introduce new and living interests into many lives whose intellectual development might otherwise have been stunted, and we may hope to bring to the service of the community in its varying needs rich contributions of equally varied ability.

SECTION M.—AGRICULTURE.

·AGRICULTURE AND NATIONAL
EDUCATION.

ADDRESS BY
C. G. T. MORISON, M.A.,
PRESIDENT OF THE SECTION.

WHEN the Council of this Association did me the honour to invite me to become the President of the Agricultural Section for this year, I was filled with some consternation and alarm as I recalled the long line of distinguished men who have filled this position in previous years, and the high standard and excellence of their addresses. One of the difficulties that I felt most strongly was that, like many of my predecessors, I was originally a chemist who had fallen under the spell of agriculture, and whose fancy had led him, in the intervals of an otherwise busy life, to work at problems of the soil. Now, engrossing as those problems are, and fundamentally important to the business of agriculture as the results of such investigations can be, I observe that no one, at any rate in the last ten years, who has been President of this section has been brave enough to discuss them in his Presidential Address. The reason of this is perhaps not far to seek. There was a period in the history of agricultural science when chemistry seemed to offer all that was needed for a successful soil study, and when the chemists of the time appeared as the magicians of the piece, at the touch of whose magic wand all secrets were laid bare. Then with increasing knowledge, my colleagues fell under a cloud and a host of other scientists began each to play his part and to add each his fragment to our simple theme, until, at the beginning of this century, there was collected so vast a body of data about the soils of the world that any orderly thinking about the subject became almost impossible. Order is, however, coming again, and coming once more at the hands of chemists, and before many years are past, perhaps one of my successors may be bold enough to try to present our knowledge of soil conditions to this audience in a suitable form. It is a task, however, for the future and not for to-day. What then was there left about which a soil chemist might venture to speak? It has been my fortune to spend most of my life at one of the old Universities, where, like many people at Oxford, much of my time and energy has been devoted to teaching, and it is because of the experience that I have had in teaching agricultural subjects and in organising agricultural curricula, and of my great interest and belief in agricultural education, that I venture to make it the subject of my address to-day.

It is not so very long ago that research and education in agriculture began to be seriously developed in this country, first, on a physical basis which is, and must remain, fundamental, dealing with the technique of

manufacture and with the elimination of waste in the manufacturing process; second, from the business side, so that the producer may have his business carried out successfully and at a profit. From the point of view of vocational training these two aspects are so closely interwoven that any attempt to magnify one at the expense of the other can only lead to disaster, whereas from the purely educational point of view the two are quite distinct, and are better treated as stages in development, leading up gradually from the purely scientific subject of the growth of the plant and animal, through the application of this science to practical requirements, to the business organisation of the fundamental producing units.

The objects of vocational education in Agriculture have been recently described by Sir Daniel Hall,¹ and further by Mr. Dale² in his paper to this section last year, and may be summarised as improvement of farming technique by making the results of recent research more readily and more rapidly available, and improvement in business management resulting from more intimate knowledge of the economic details of the particular farming business and a wider acquaintance with the economic position of the whole industry.

The development of technical education in this country has had for one of its aims the improvement of farming methods by creating a class of farmers who have had the benefit of a training at either a Farm Institute, an Agricultural College, or a University, according as he could spare time and money to pursue his studies. At the conclusion of these studies the presumption is that he will spread the light of his knowledge and his skill in his neighbourhood and, by the strong force of his example, cause an improvement in the methods of his neighbours. Thus would the country benefit from the greater yields per acre which would be grown, and the farmers themselves from their more satisfactory economic position.

Unfortunately for the industry things do not work out quite so simply. The number of those who, on leaving the Universities and Colleges, engage in farming and set the shining example I have mentioned are none too many, and the effect in this way upon farming practice has not been as great as might have been expected. The great landlords too, with certain notable exceptions, have hardly lived up to their eighteenth-century tradition in taking the place which is theirs naturally as leaders of the countryside in agricultural and farming affairs. Even the country clergy, who seem in the eighteenth century to have been knowledgeable in these matters, have apparently lost heart. Thus it appears that, despite all the money which is annually spent on higher education, there is not going forth into the countryside from our Universities and Colleges that stream of well-informed and well-educated young men and young women whose influence would so greatly modify farming practice up and down the land. For let us be quite candid about the situation: British farming at its best as it is carried out by certain individuals and in certain districts—and that there is a greater concentration of these individuals in some districts no one will deny—is second to none all the world over. There are, however, a large number of farmers whose technique is poor, whose methods are slovenly, and whose general standard falls very far

¹ *Scottish Journal of Agriculture*, vol. x, p. 135.

² 'Progress of Agricultural Education in England and Wales.'

below that of the best. I cannot but believe that even in the present difficult and harassing economic situation their position would be better were their standards somewhat higher, and their aim to increase rather than decrease their output.

The improvement in farming technique has been sought by the methods described by Mr. Dale, which consist in affording in all parts of the country access to three types of education, provided by means of University departments and Colleges, by Farm Institutes, and by local classes and lectures. Each of these types has a separate function in the whole scheme and, while the part played by local classes and by the Farm Institutes seems clear enough, the policy of the Colleges and the Universities is often rather vague and indefinite. If it is possible to make a criticism against these bodies in the last years it is this, that, while they one and all would, I imagine, claim that their function was to train their students in the technique of the agricultural business, so that as managers and occupiers of land, land agents, teachers, experts or officials they could raise the standard and status of the industry, they appear to think that the different educational requirements of these various classes can be obtained under the same general scheme of instruction. There are, of course, great difficulties in the way of any one of these institutes definitely adopting a course designed to give the maximum benefit to any one of those classes which I have enumerated, but I think that in some cases at any rate the beaten track has been preferred, and the old methods have been considered good enough to suit conditions that have largely altered. I am convinced that only by taking careful stock of the whole situation, and by being perfectly clear about the result aimed at, can the money which is to-day expended upon agricultural education have the desired effect.

It was pointed out by Mr. Dale in the paper already referred to that, if the case of wage-earners be excluded, the facilities in Universities, Colleges, and Farm Institutes were equal to the demands made, but that if these demands were as great as they should be, then the existing institutions would be overwhelmed. According to Mr. Dale's figures, the Colleges are only two-thirds full, and of this number only one-third are the sons and daughters of farmers. Something is wrong here, and until this is put right, excellent as is the work done by these institutions, it has not the effect upon the industry in this country which its excellence deserves. No doubt a fairly large proportion of these students learning agriculture will have some influence upon the industry in the future, but it is within my own knowledge that there are a considerable number of agricultural students in a University such as Oxford whose connection with agriculture subsequent to their leaving the University is very slight. I do not propose to traverse here already well-trodden ground in attempting to explain why there is not a greater demand for technical training in times of stress like the present. I believe that, while many factors contribute, it is mainly an economic question, and that the ordinary tenant-farmer is to-day in a position in which he can ill afford to spend money, even were he sufficiently farseeing to realise the ultimate benefit that would result. Such then is the main direction in which it appears to me that improvement in higher education is required, and this improvement must be achieved by a greater vision and clearer purpose on the part of

these institutions, and by a greater appreciation on the part of those whom they are designed to serve.

So far in this scheme of vocational training only the actual farmers have been considered; nothing has been done to meet the needs of the manual labourer, and not very much to give the landlord a training suitable to his position as one of the partners in the industry.

The case of the manual worker is one of most urgent need; little or nothing is done to give him or her any kind of vocational training, and this in spite of the fact that the whole position of the industry at the present time, more than ever before, depends upon the efficiency of the labour unit. This aspect of agricultural education was dealt with by Mr. Duncan both at the Oxford Meeting and subsequently in an article contributed to the *Scottish Journal of Agriculture*,³ and it appears from this that no educational effort is being made to make the manual worker more efficient or to enable him to increase the value of his output. Mr. Orwin⁴ has recently stated that the lad who remains on farm work definitely occupies a lower social position than those of his own age and district who seek the more highly remunerated work that can be obtained in the towns. Wireless and the motor-bus have done much to enliven rural conditions, but they really only succeed in emphasising the superficial undesirability of country life, country wages, and a country outlook. As Mr. Duncan has pointed out, until wages are higher, and until the skill of the worker enables him to earn those higher wages, agriculture will always be left with the more inefficient and the less active-minded of the countryside. The difficulties in the way of rendering labour more efficient are very great; the tasks to be carried out are so various, the possibilities of the use of machinery so limited, and the effective over-seeing, which is responsible for much of the success in other industries, is almost impossible. The comparative failure of agricultural trade unions means that there is not the continual pressure for improvement that there is elsewhere. If labour became more efficient the result would be either that the same amount of work could be done in the same time by a smaller number of men, or a larger amount of work done in the same time by the same or a smaller number of men.

Now extensive agriculture in the newer countries is characterised by a large production per man engaged in the work, while in more intensive agriculture in the more settled countries a lower production per man is obtained, although the production per acre may be more than double. The urgent practical problem is to increase production per man while at the same time maintaining or increasing production per acre. All this implies technical skill of no mean order on the part not only of the manager but also of the manual worker, and to my mind it requires something more, something which makes the acquiring of technical skill a comparatively easy matter, and that something consists in a good general and continued cultural education. There is no doubt, I think, that education, cultural education apart from vocational training, is held in greater respect in all those parts of the British Isles which are not English. It is certainly true of Ireland and of Scotland, and, I understand, of Wales.

³ *Scottish Journal of Agriculture*, vol. x, p. 28.

⁴ 'The Transition of Agriculture,' *Journal of the Royal Society of Arts*, May 20, 1927.

England alone stands unconvinced. It is of course difficult to measure the extent to which general education contributes to mental alertness in later years, but there is often among farmers, and among the rural population generally, a certain lack of elasticity, a certain dullness of outlook, which will have to disappear if agriculture is to take its rightful place among the other great industries of the country. The skilled manager, the skilled man, the educated manager, the educated man—if it pays to employ these, and it does appear to do so in other industries, then much more should it be remunerative in agriculture, where the calls on the management are so multifarious, the task so difficult, and the skill demanded of the manual worker so very varied.

Let us now examine how a development of this kind affects the three partners in the agricultural business as we know it to-day—the landlord, the farmer, and the manual worker.

The landlord may, or may not, remain as a permanent partner in the agricultural industry; but while he does remain the power that he possesses of influencing the whole industry is enormous. Those of us who were privileged to hear Lord Bledisloe's address when he was President of this section will well remember his almost passionate appeal to the landowners of to-day to follow the example set them by their illustrious predecessors, and take upon themselves the position of leaders and organisers of the agricultural industry. Some there are of course who, like Lord Bledisloe himself, have taken up this burden, and whose names will be remembered as we remember those of the great leaders of the eighteenth century. 'The agricultural community in Britain to-day,' said Lord Bledisloe at Hull in 1922, 'above all else needs enlightened leadership, just as agriculture needs efficient organisation; and the landowner, if, after due training, he would but take his proper position, should be both leader and chief organiser.' This need for leadership all over the world is as great to-day as it was then, and, while the owners of the soil supply leaders in almost every branch of this country's activities, they undoubtedly do so in smaller numbers in the very industry from which they have derived their position. This leadership is only possible to-day through suitable education, and if it is possible to provide suitable education for any class in the community, it should be possible in this case. The preparatory and public schools of this country, great as their faults may be, do undoubtedly at their best furnish an education which in certain aspects is surpassed by none, and provide a training in citizenship and leadership which it is difficult to equal. Specialisation and vocational training are, however, relegated to the last years of a public-school career, and so far in this country agriculture has been treated as a purely vocational subject, to be dealt with shortly in the secondary school as a preliminary to a fuller course in the subject at a subsequent stage. So the prospective landlord passes from the school stage to the university, where now he may, if he be so minded, spend the whole of his time completing his cultural and technical education and training himself for this occupation of leadership. And if the schools and universities of this country live up to their reputation, and if the latter seriously attend to the provision of the most suitable curricula, the education and training will be sufficient. In Lord Bledisloe's words, 'their traditions are great, but their future

destiny is greater if they have but the vision, the courage, and, above all, the will to press resolutely forward towards the goal to which public duty and material advantage alike point the way.'

What, then, is the actual farmer's position? On him the greater part of the burden falls; how does the education provided help him to support it?

In the case of the larger farmers general education and technical training will be provided by means identical, or nearly so, to those I have already discussed, and they with the landowner must share the burden of leadership, leadership not only in technical skill and administrative ability, but also in the more difficult task of building up a new rural life. In the case of the smaller farmers the facilities are not so complete; the majority of these get their education at the local grammar schools, which usually require that a boy shall enter before the age of twelve and shall stay until the age of sixteen. In this way it should be possible to secure that the general education is satisfactory, and that it should have what is called a rural bias, or at any rate be closely related to environment in country districts. It has been shown by a committee of this Association on Training for Overseas Life that quite a number of grammar and secondary schools have introduced some agricultural work of a kind which may be regarded as semi-vocational, as something which would definitely be of service when the boy leaves school, as he usually does, between the ages of sixteen and seventeen. Definite technical education is subsequently provided by the Agricultural Colleges, by the Farm Institutes, and the activities of the County Council officer in the way of lectures, demonstrations, visits to institutions, discussion groups, and young farmers' clubs. I feel, however, that this is not enough, good though it frequently is and excellent as it may become. Something further is required, some scheme whereby education may be continued in later years and not cut off short at the time when it is perhaps most worth continuing. Is it too much to hope that there may develop in this country something in the nature of a rural university which shall continue education, and shall continue it on university lines? If I am correct, what is needed is not a greater volume of technical instruction but a greater desire for technical instruction and a more educated habit of mind, which I believe can only be obtained in these cases by an improvement in, and a continuation of, general education to a later stage.

It is frequently, though not universally, held that much of the success of modern Danish agricultural organisation is due to the existence of the famous Folk High Schools,⁵ virtually rural universities, providing as they do in a manner which is unique the advantages of a residential university. It would take too long to examine the claim that has been made that without these schools Danish agricultural co-operation and Danish agricultural progress would have been impossible, but even if we make allowances for the enthusiasm of the believers, it is certain that much of the mental alertness and spirit of mutual help so essential to success has been acquired in the High Schools. In Denmark even up to the present day these have been almost entirely a rural development; the towns have

⁵ 'The Folk High Schools of Denmark and the Development of the Farming Community,' by Holger Begtrup, Hans Lund, and Peter Manniche.

been unwilling and slow to support the movement. It must be frankly admitted that it does not appear possible, with the English outlook on education, to transplant the High-school system into this country, but I do believe that in the development of the spirit which led to their foundation lies the greatest hope for the future of rural England. How far is it possible that this work can be carried out through the instrumentality of such organisations as the Extra-mural Delegacies of the Universities, Rural Community Councils, Women's Institutes and other bodies which are interested in the regeneration of the countryside? The success of the Women's Institutes has been very remarkable, and the potentialities of the Extra-mural work of the Universities are as yet hardly explored. If we look at the report of the Extra-mural Delegacy of my own University, we shall see that courses, which have been more or less well attended, have been given in purely rural areas on such subjects as 'Citizenship and How England is Governed,' 'Industrial History,' 'Current Economic Problems,' all of which themes, to mention only a few, might be expected to interest a country audience. Some of the lectures deal specifically with rural affairs and their development, and it is interesting to learn that in the smaller centres, in the more purely agricultural districts, the audience generally consists of the parson, the schoolmaster, village shopkeepers, sometimes farm labourers and their wives, frequently farmers' wives, but practically never the farmers themselves. I do not pretend to know what is the reason for this abstention on the part of the farmers, but it does indicate an attitude of mind that is to be deplored, and which must hinder any attempt to improve rural conditions.

Turning next to the case of the wage-earner in the industry, as has been pointed out by Mr. Duncan, nothing has been attempted so far which will either improve his technical training or prolong his education; the improvement, such as it is, that has been effected in the skill and knowledge of the farmer has only intensified the difference between master and man. One of the real needs of the industry is to keep the best men on the land, not those who for one reason or another get left behind in the race to the towns, and this will only be possible when the employer can pay wages comparable with those which can be obtained in other industries. This he is unable to do, and will continue to be unable to do, until it is possible to increase the value of the worker's output. I would here remark that in other industries employers have found out the value of prolonged education, as well as of vocational training, and the real worth of continuation classes has been clearly demonstrated. Is it too much to hope that something of the same kind may happen in the industry in which we are all interested? Much is being done towards the improvement of elementary education, and many persons are interested in this side of the problem. The development of Senior Country Schools and the possibilities that are to be found in such a scheme of fostering a liking for, and an understanding of, rural affairs are all happy auguries for a brighter future. Any improvement that can be effected, however, in the ordinary schools is likely to be very largely sterile, unless it is possible to continue this education over the critical years that follow the school-leaving age. Is it too much of a dream to look forward to an improvement in the general education and training of those who are engaged in agricultural pursuits,

to a time when farmers up and down the country will feel that there is something worth while in an education and a standard of culture and technical knowledge beyond that to which they have been accustomed, and when they will be prepared adequately to remunerate good men whose output is high, and when the men themselves will realise that only if they have adequate education and training can they expect to earn wages comparable with those paid in urban industries ?

I desire to turn now to two other aspects of agriculture in relation to national education, one of which I regard as having very great significance from the point of view of the industry itself, and the other as being at this stage in the development of the world of paramount importance to every civilised community. It has long been the complaint of persons interested in agriculture that it is very difficult to arouse intelligent interest in the minds of those persons in the country who are not either directly or indirectly concerned with the industry. There have, of course, been times in the history of every country when circumstances such as scarcity of food, or even the possibility of actual starvation, have drawn the attention of the whole population to this question. Under such circumstances governments may have to act precipitately and commit the country to this or that policy without sufficient consideration. Such a course is fraught with much danger, especially when dealing with an industry like agriculture in which changes can only come slowly and gradually. In the present day, when our needs are satisfied by produce from all parts of the world, and when only a small portion of the food consumed both in the towns and in the country is provided by our own soil, is it not time that some effort was made to inform the whole body of consumers, not only of the way in which the food is produced, but of the manner of life of those who produce it, and of the mode of its arrival in their midst ? So smoothly does the machinery of production and distribution appear to work that the consumer is apt to think it automatic, and to take the arrival of these necessaries and luxuries almost as the falling of manna from heaven. Only by education, only by creating an informed opinion about agriculture among both the urban and rural populations in this country, can the mass of the people come to realise the peculiar circumstances of the farming community, and the difficulties with which their business is faced, and the particular problems that affect the countryside as distinct from the towns.

To proceed still further, Sir Daniel Hall, in his Presidential Address last year, emphasised the fact that the continued expansion of the earth's population and of the white races in particular, as representing the highest material standard of living, will demand either a great expansion in the area of land under cultivation, or an intensification of production in the area at present utilised. It is apparent from the papers that have been written in America by Dr. E. D. Ball,⁶ that, even in the United States which has up till recently been a large exporter of food, the question of a national agricultural policy is regarded as most urgent. He asserts that the United States will only maintain her world position and

⁶ Dr. E. D. Ball : ' Shall we have a Policy of Future National Development ? ' ' The Future of Agricultural Research. ' ' The Need of a Food Supply for an Increasing Population. '

her extraordinary development just as long as she can remain a food-exporting nation, and this can only be achieved if the whole energies of her scientific men are devoted to the intensification of production upon land already farmed. The need for this intensification appears then to be as great in America as here, and this calls for continued scientific research, not so much to ensure the benefit of any particular class of the community, however deserving, but because the nation needs it, because it is vital to the life of each and every individual. In Sir Daniel Hall's view the area of suitable undeveloped land available is insufficient to provide the increase of food required, and, in his own concluding words, 'how close at hand the period of pressure may be it is unsafe to prophesy, but it may be agreed that pressure is sooner or later inevitable, and that one of the biggest problems before the world at present is to prevent the pressure developing suddenly and becoming unbearable. The intensification of production is the only remedy, and again the only means of rendering intensification practicable is the continued pursuit of scientific research.'

This intensification of production must come sooner or later in an ever-growing population, and can only be brought about by increasing knowledge and improving technique. Before this intensification can occur, the nations must realise the need for further investigation and research, and this they will only do if and when there exists among the citizens of every civilised community a widespread knowledge of this the most basal of all human activities.

If it be admitted that it is desirable for each boy and girl to know something of the way in which their bread and meat are produced, something of the lives of those who produce it, and something of the sources of the food supply of their country, can the acquisition of this knowledge be justified on general educational grounds, and, if it can, is it practically possible? I assume that few would dispute the statement that the purpose of education is to enable a man to live a fuller and better life and to make a better use of his environment. Education must prepare for life and for the conditions which will be met throughout its course. Dr. Jesse Jones,⁷ in a book published last year, has endeavoured to simplify the problem of general educational policy, and to make us consider anew its fundamental purpose. As a result of his wide observations over three continents, and his experience of many different manners of education, he urges upon us to-day the importance of resisting what he terms 'Education by accretion,' and 'the need for an approach to education that is sufficiently fundamental to be accurate and sufficiently simple to be practical.' He finds the solution of his problem in what he terms the 'vital consciousness of community conditions,' and defines as one of his four fundamental educational elements 'appreciation and use of environment.'

Whether we agree entirely with Dr. Jesse Jones or not, most of us would, I think, agree to this, and most of us would further agree that the most fundamental subject that can be considered in man's environment is the satisfaction of his most urgent bodily need. The Committee of this Association which considered the question of Training for Overseas Life, while quite definitely regarding the question from the vocational angle,

⁷ 'Four Essentials of Education.' Thomas Jesse Jones.

brought to light some very interesting opinions about the possibility of dealing with agriculture as a cultural subject in schools. In the first report of the Committee presented at the Toronto Meeting occur the words: 'the undoubted value of agriculture as an educational instrument has been overlooked in the past.' In various parts of Canada the view has been deliberately taken that the study of agriculture has definitely a cultural as well as a vocational value. In nearly all the newer countries agriculture forms part of the curriculum of the secondary schools, where, however, it is regarded by many as more vocational than cultural, because of course these countries are very largely rural, and depend more directly upon agriculture for their existence. Now, although as I have indicated, the Committee was concerned with the training of boys and girls who definitely propose to go into farming overseas, these interesting opinions about the value of agriculture as an educational subject emerge. One further sentence may be cited. 'Overseas opinion . . . is much better informed and more advanced than in England, with the consequence that in the Overseas Dominions a considerable body of experience has been accumulated, which has led the way to a definite adoption of practical work on the land, wherever possible, for the urban school equally with the rural school.' That is an indication of the lengths to which they are prepared to go in those countries where a considerable, or it may be an overwhelming, number of their pupils go into an agricultural career. The case in this country is, of course, quite different, but nevertheless I would urge that, in spite of the small number of those who take up farming as a profession at home, and in spite of the comparatively small number of those who go abroad and do so in the Dominions or elsewhere, a study of agriculture as a cultural subject is more than worth while because of the basal character of the industry, the fundamental importance of its products, and the particular position of this country with respect to the food supplies of its people. The question naturally arises as to what is meant by the study of agriculture in this connection, and, while it is a question to which it is difficult to give a final answer, it is one to which a reply can best be given by considering how this subject could be developed throughout the schools and Universities. Nature study, illustrated and taught by means of school gardens, forms an integral part of the teaching of most elementary schools, and it is a matter for regret that in many preparatory schools this teaching is not attempted. If this study be properly carried out, I think that it meets the first demand which I would make that, in the elementary stage, children should have some slight acquaintance with the plants and animals with which they are surrounded and which supply them with the necessaries of life. In the next stage, that of the public and secondary schools, formal science is a definite part of the instruction provided and of the syllabus for the school certificate and for admission subsequently to the Universities. In my opinion, much of this science is too formal, too broken up into separate subjects which appear to have little connection with each other, and no connection at all with the facts and problems of everyday life. Certain improvements have been made of late, and the inclusion of General Science as an examination subject in the University Local Examinations and in that of the Oxford and Cambridge Joint Board are all steps in the right direction. Science for

the ordinary pupil seems to me still to suffer from too much formalism, and too great a regard for, and belief in, experimental work in the laboratory. Too much practical work in the laboratory is impossible for the boy or girl to whom science is going to be a profession, but it is fatally easy to attach too much importance to the laboratory if the whole of scientific education is to be limited by what the pupil can illustrate in those laboratory experiments that he has time and ability to perform. May I refer to the Presidential Address given to the Education Section by Sir Richard Gregory at Hull in 1922, in which he says 'the essential mission of school science is to prepare pupils for civilised citizenship by revealing to them something of the beauty and the power of the world in which they live,' and again, 'reading or teaching for interest, or to learn how physical science is daily extending the power of man, receives little attention.' The whole tenor of his address was a plea for the expansion of scientific instruction in this humanising spirit, an end which can, I believe, best be brought about by dealing with elementary science in relation to plant and animal life, to agriculture, and the food supply of the world.

I will not weary you with details of suggestions of what I think school curricula might be. I only want at this stage to make the suggestion that for the average pupil, who will make little or no vocational use of his knowledge later in life, science should be approached from the plant and animal ends, that is, from the point of view of the environment of each of us, and developed into an elementary knowledge of the employment of plant and animal by man for his subsistence, of the means whereby these plants and animals are made to satisfy man's ever-increasing needs, and last, but by no means least, some slight knowledge of how this country obtains its food supply. A development of this kind would not mean the introduction of another subject into a curriculum already overcrowded, if it meant that elementary science for the normal boy consisted of this work. Naturally as the subject developed the applications of science to other industries would find their place, and would form part of a coherent whole, but the central idea would remain.

What now is the part which the Universities must play in a scheme of this sort? They should provide courses which would aim at giving their students, and these will represent the specialists in the subject, a general knowledge of what agriculture has meant in the past, is meaning to-day, and must mean in the future. To accomplish this, as I see it, some knowledge of technical processes is necessary, some contact with the soil is desirable, and some study of practical agricultural methods is essential, but let us be quite clear that this is only a small part of the whole study, which will demand far deeper inquiry and far wider reading than is usual among students of agriculture in the Universities. So far as I know, no University has had an end of this kind in view in framing its agricultural curriculum. The curriculum at Cambridge is largely a modern development of the older methods adapted to suit the needs of that University, and to train men to become managers of land. We, in Oxford, have had that view in mind also, but we have I think gone farther towards developing a course of study along the lines I have indicated. An undergraduate at Oxford may take for his final examination in Agriculture three subjects, (1) Agriculture from the practical and technical side, (2) Economic Theory

and the Economics of Agriculture, and (3) the History of Agriculture in Great Britain and Ireland and Comparative Agriculture, this last signifying a study of current conditions in the more important agricultural areas of the world. A study such as this seems to me to form the foundation of such a curriculum as I have in mind, and to represent more nearly than anything else a non-vocational agricultural education. This study will demand from the student some knowledge of physical science in order that he may understand the technical, that is, the manufacturing, process, for it is impossible to understand even in the most general way the relations of soil and plant, plant and animal without some scientific training, and this student of mine must be able to have an intelligent opinion about present practices and future developments. It is not, however, on the side of physical science that most of his work will lie. The chief development, as I see it, will consist in a wider and deeper study of economic science so that finally his knowledge of agriculture will include not only the history of the industry in this country, but in the world as a whole, and will be a study of economic history and economic geography of the first importance. An interesting new departure has been made by the University of Bristol in introducing the study of Agricultural Economics as an optional subject for the Final Honours Degree in Economics. This is all a move in what I consider the right direction, but for my part I would go still farther and make a study of the economics of British Agriculture not optional, but compulsory, for those taking a degree of this kind.

Such a course as I have tried to indicate would then run side by side with the ordinary vocational and professional course, and would, I hope, in time be taken by a large number of persons who had no intention of engaging in practical agriculture, but who would form a nucleus of informed opinion that could not fail to produce an effect upon the fortunes of the industry and upon the whole of rural life. Thus, even more perhaps than by creating a class of farming landlords who would play to-day the part played by their predecessors of the eighteenth century, would it be possible to recreate the countryside, to build up a new rural order, under the enlightened leadership of those who have studied fully and carefully the problems of country life and the problems of country industry as they have varied throughout the centuries.

I have ventured to put before you what I believe to be the great needs of the agricultural community—greater light in its own ranks and a public better informed of the needs of the industry and of its own requirements in the matter of essential supplies. It may be urged that much of what I have said is unreal and bears little relation to facts as they are, and, above all, offers no immediate help to the farming community in its present need. This last I admit is true. Others with more practical experience are attempting that almost daily. Some indeed would soothe the sufferings of agriculture with drugs which can afford but a temporary relief and, without removing the trouble, lull the sufferer into a false sense of security. I have tried to go beyond this, and in so doing have come to the conclusion that what is most fundamentally vital to the industry and to the whole body corporate is a new attitude of mind towards education and a true realisation of the value of cultural studies as distinct from vocational training, the worth of which all would, I trust,

readily acknowledge. If, and when, this realisation comes to pass there will, I believe, develop all over the English countryside a class of landowners who are informed about country affairs, a class of farmers who are able and willing to pay rates of wages comparable with those which can be obtained in other industries, a class of workmen who by their skill and the value of their output make this rate of wages possible, and a general community which realises the value to itself of a flourishing agriculture, and is capable of thinking intelligently about the future of that industry, and of facing with knowledge the problems of its own food supply. Then, and only then, shall we be able to build up the new rural civilisation of which so many have dreamed.

REPORTS ON THE STATE OF SCIENCE,

ETC.

Seismological Investigations. — *Thirty-first Report of Committee* (Prof. H. H. TURNER, *Chairman*; Mr. J. J. SHAW, *Secretary*; Mr. C. VERNON BOYS, Dr. J. E. CROMBIE, Dr. C. DAVISON, Sir F. W. DYSON, Sir R. T. GLAZEBROOK, Dr. HAROLD JEFFREYS, Prof. H. LAMB, Sir J. LARMOR, Prof. A. E. H. LOVE, Prof. H. M. MACDONALD, Dr. A. CRICHTON MITCHELL, Mr. R. D. OLDHAM, Prof. H. C. PLUMMER, Rev. J. P. ROWLAND, S.J., Prof. R. A. SAMPSON, Sir A. SCHUSTER, Sir NAPIER SHAW, Sir G. T. WALKER, and Mr. F. J. W. WHIPPLE.) [*Drawn up by the Chairman except where otherwise mentioned.*]

General.

THE Milne bequest of £1000 mentioned in the last Report, together with the previous bequest from the late Matthew H. Gray, of Lessness Park, Abbey Wood, has been placed in the hands of the Official Trustee of Charitable Funds, as a British Association Seismological Trust. The income from the Trust will be paid over to the Westminster Bank (Oxford branch), and will be at the disposal of the Chairman for the time being of the British Association Seismology Committee. The arrangements have involved some correspondence and consequent delay, but are on the point of completion.

A memorial stone to John Milne and his wife was, in November 1926, set up at Hakodate, in the graveyard of the Horikawa family, by subscriptions from ninety-seven of Milne's former pupils at Tokyo. Initiative in this matter was taken by Prof. Imamura of Tokyo.

The University of Oxford has now sanctioned the extension of the University Observatory by four rooms to the east of the present buildings, together with a basement below them for the reception of the two Milne-Shaw pendulums, which are at present, by the courtesy of Prof. Lindemann, mounted in the basement of the Clarendon Laboratory. Excavation for the basement has already been made, and it is hoped that the work will now go forward without further delay. (See Report for 1925.)

The salary of Mr. J. S. Hughes has been provided, half by Dr. Crombie and (after six months' interval, during which it fell on the funds of the University Observatory) half by the Royal Society. Under his supervision the current reductions have gone steadily ahead. (See below under Bulletins and Tables.)

The telegrams from Fordham University have ceased to come, probably in consequence of the formation of the Jesuit Seismological Association in the United States; but on one or two important occasions very helpful telegrams have been received from Helwan, from Hyderabad, and from Perth (W. Australia). A conspicuous instance was the great shock of 1927, May 22d, 22h, in Kansu, Western China, which must be put alongside the shocks of 1920, December 16, in the same neighbourhood, and those in Japan in 1923, September 1 and 2, as the four greatest shocks of recent years. Telegrams from Helwan, Hyderabad, and Perth enabled us to fix the epicentre at 35.8° N., 103.4° E., some 2.3° to the west of that of 1920, December 16, and this position was communicated to *The Times* of May 25, with the information that the intensity exceeded that of its predecessor. But conditions in China are so much disturbed that it was not until June 21 that news was received direct from the neighbourhood of this 'terrific earthquake.' A month later, under date July 29, Mgr. Buddenbrook, Vicar-Apostolic in Kansu, reported that the 'city of Kulang has absolutely disappeared. He estimates that the range of the earthquake was seventy miles, and that 100,000 people were killed.' He himself was at the time celebrating Mass at Lanchow (the capital of Kansu) and was hurled from the sanctuary into the open. (*The Times* of July 30.)

Dr. C. Davison has added to our obligations to him by publishing a new work on the *Founders of Seismology* (Camb. Univ. Press, 1927, 12s. 6d. net), in which special appreciation is accorded to the work of three Englishmen, Michell, Mallet and Milne.

At the end of the Oxford Meeting of the British Association, our Secretary, Mr. J. J. Shaw, was attacked by serious illness, and was ultimately ordered abroad.

Fortunately the special treatment suggested has been very successful, and Mr. Shaw was able to attend the meeting of this Committee on July 4, though he is still in the doctor's hands.

International.

The *International Scientific Summary* has been continued as below, by the help of a supplement from the Royal Society, to counteract the effects of the fall in the franc.

The Prague meeting of the Int. Geoph. and Geod. Union has been fixed for September 1-10. The Chairman and Secretary of this Committee have been nominated as delegates.

Instrumental.

(Chiefly from notes by Mr. J. J. Shaw.)

Mr. Shaw completed the repairs to the Christmas Island machine before leaving England; it is now at Colombo, and has been purchased by the Ceylon Government.

As foreshadowed in the last Report, the original Milne-Shaw instrument, set up at Bidston in 1914, July 16, and recently replaced by another with larger magnification, has now been set up at Oxford as a N.S. component. It has the same magnification as the existing E.W. component, and there is a convenience in having the two instruments alike in this respect. When the new basement at present under construction at the University Observatory is completed, the two components will be mounted on the same pier. At present they are mounted on the two separate piers erected in the basement of the Clarendon Laboratory by Mr. C. V. Boys, F.R.S., for his Cavendish experiment in the years 1891-1895. (See *Phil. Trans.* 186 (1895), A. pp. 1-72.). The use of this basement has been courteously allowed by Mr. James Walker in the first instance (October 1918), and by Prof. Lindemann since his appointment in 1919.

On April 11, 1927, a second instrument was sent to Copenhagen for installation in Greenland. Earthquakes in the Arctic regions are occasionally recorded by European instruments and others (for instance, the catalogue of epicentres 1913.0-1920.5, published three years ago, contains ten epicentres with latitudes greater than 63°, of which the most active is that of 72.0° N., 2.8° W., from which six shocks are recorded, none of the other epicentres being credited with more than one); but it is suspected that others escape detection, and a pair of components in Greenland will be very valuable.

The following note is contributed by the Superintendent of Kew Observatory:—

'An event of some importance to British seismology, the transfer by the Meteorological Office of the Galitzin seismographs from Eskdalemuir Observatory to Kew Observatory, should perhaps have been mentioned in last year's Report. The instruments, which were provided in 1910 by the generosity of Prof. (now Sir Arthur) Schuster, were moved in October 1925. The pendulums were installed at Kew Observatory on a massive concrete pillar in the old magnetograph room, accommodation for the photographic recording apparatus being provided in the room formerly occupied by the Milne seismograph. The instruments have been in continuous operation since the beginning of 1926.

'The Observatory now supplies the Air Ministry with information regarding important earthquakes for communication to the Press, and messages in the international seismological code are sent out by the Meteorological Office with telegrams of the daily weather service. At the beginning of 1927 the issue of a monthly bulletin, to take the place of that issued previously from Eskdalemuir, was inaugurated. Fuller details of the seismological records, including measurements of microseisms, are being published in the Observatories' Yearbook of the Meteorological Office.'

Bulletins and Tables.

The *International Seismological Summaries* for October to December 1922, and the whole of 1923, have been printed and distributed. The number for January-March 1924 is passed for press, and the MS. for April-June 1924 is being read with the original records. [It has been the custom, almost from the first, to treat such MS. as printer's proof, so that very few corrections are needed after it is set in type.] During the year the great earthquakes of 1923, September 1 and 2, in Japan, came

under discussion, naturally adding a good deal both to the work of the year and the printing bill.

The discussion of the P and S residuals for the five years 1918-1922 has been completed and published in the *Geoph. Supp. to the Monthly Notices R.A.S.* Copies of the paper will be distributed to the various stations along with the number of the *Summary* for 1924, January-March. One incidental outcome of the discussion is that there seems to be near $\Delta=57^\circ$, a minimum frequency of records both in P and S. The following are the ratios of totals (on an arbitrary scale) to the areas of successive zones of the earth's surface, 5° in width :—

Δ	P	S	Δ	P	S	Δ	P	S	Δ	P	S
°			°			°			°		
2.5	2.2	.92	27.5	.64	.57	52.5	.21	.21	77.5	.31	.31
7.5	1.2	.76	32.5	.43	.40	57.5	.17	.18	82.5	.38	.42
12.5	0.75	.44	37.5	.31	.29	62.5	.19	.20	87.5	.31	.39
17.5	0.71	.56	42.5	.23	.21	67.5	.18	.20	92.5	.15	.15
22.5	0.65	.60	47.5	.24	.24	72.5	.23	.25	97.5	.11	.11

The phenomenon may, of course, be a simple consequence of the particular distributions of epicentres and observatories. The former tend to be near the Philippines, and the latter in Europe, at distances not far from 90° ; and this may cause the rises in the ratio after $\Delta=67.5^\circ$, which might continue to fall with a more uniform distribution. But the point is worth further examination.

The corrections to the adopted tables may be represented as follows :—
 Firstly, if we take the simple maximum of the residuals in P we get

CORRECTIONS TO TABLES OF P.

Δ	Corr.	Δ	Corr.	Δ	Corr.	Δ	Corr.	Δ	Corr.
°	S	°	S	°	S	°	S	°	S
2.5	+2.9	27.5	-1.6	52.5	+0.8	77.5	+ 0.7	102.5	-16.5
7.5	+2.2	32.5	-7.3	57.5	+1.7	82.5	+ 0.2	107.5	-17.8
12.5	+0.6	37.5	-8.8	62.5	+1.9	87.5	- 4.3	—	—
17.5	+1.8	42.5	-1.9	67.5	+1.6	92.5	-10.2	—	—
22.5	-0.6	47.5	-1.4	72.5	+1.8	97.5	-12.8	—	—

It will be seen that besides the well-known negative errors after 85° , there is a considerable error near 35° . But this is accompanied by a curious apparent duplicity in the maximum, which is even more striking in the case of S than of P. The results may, therefore, be presented more fully as follows :—

CORRECTIONS TO ADOPTED TABLES FOR P AND S.

Δ	P		S		Δ	P		S [S]	
°	S	S	S	S	°	S	S	S	S
2.5	+2.9	—	-2	—	57.5	+ 1.7	+ 3	—	—
7.5	+2.2	—	+2	—	62.5	+ 1.9	+ 2	—	—
12.5	+0.6	—	+2	- 6	67.5	+ 1.6	+ 1	—	—
17.5	+1.8	—	+2	-10	72.5	+ 1.8	0	+ 25	—
22.5	+0.5	- 2.5	+0.7	-16.8	77.5	+ 0.7	- 3	+ 12	—
27.5	-1.5	-19.9	+3.0	-17.3	82.5	+ 0.2	- 5	- 11	—
32.5	-6.3	-28.5	-4.8	-28.6	87.5	- 4.3	- 8	- 34	—
37.5	-5.0	-21.0	-7.0	-30.3	92.5	-10.2	-13	- 57	—
42.5	0.0	-18.6	-1.5	-28.2	97.5	-12.8	-22	- 80	—
47.5	-1.4	—	-0.4	-14.0	102.5	-16.5	-30	-103	—
52.5	+0.8	—	+2.5	- 7.0	107.5	-17.8	—	-126	—

It will be seen that the adopted tables are in the main correct with the following exceptions:—

(a) For values of Δ from 20° to 50° there appears to be a double maximum in both P and S. The principal maximum is not far from the tables, though both P and S tables require a small negative correction near $\Delta=35^\circ$. The subsidiary maximum may either be real and distinct, involving a considerable departure from the tables, in which case the question arises which are the true P and S. Or it may be that the duplicity of maximum is spurious, and in that case the correction to tables must lie between the two values, much nearer the numerically smaller.

The most interesting hypothesis is that the weaker and earlier maximum represents the true P and S, or at any rate provided the angles of emergence measured by Galitzin. If that is so, there is no difficulty in explaining why he could not reconcile his values for the angle of emergence with the adopted tables for P, for the corrections indicated above introduce a point of inflexion into the graph of δP .

(b) For values of Δ from 70° to 115° observations of S are liable to be observations of [S] or $S_c P_c S$, Gutenberg's wave which goes through the central core of the earth as P. Attention was drawn to this phenomenon in the last Report.

Various suggestions have been made for the improvement of the existing tables, many of them based on the results for a single earthquake. The present discussion of the results for a large number of earthquakes scattered over the earth during five years suggests that there are several difficult questions to be considered before any change in the adopted tables is made. Any such change is bound to cause confusion, especially if it is made while our knowledge is still imperfect.

Deep Focus.

From the above-mentioned discussion of the large earthquakes in 1918–1922 the cases of abnormal focus were excluded. They represent another fundamental question on which opinion is divided. The cases of abnormal focus are a small percentage of the whole, but are by this time sufficiently numerous to constitute a considerable body of evidence in favour of the hypothesis put forward. The following is a summary of the cases. The four quarters of the year are denoted by I, II, III, IV.

CASES OF ABNORMAL FOCUS.

Year.	High Focus.				Total.	Deep Focus.				Total.
	I.	II.	III.	IV.		I.	II.	III.	IV.	
1916 .	—	—	—	2	2	—	1	1	—	2
1917 .	—	2	—	—	2	—	1	—	—	1
1918 .	—	—	4	—	4	1	3	—	4	8
1919 .	—	3	—	1	4	8	3	3	3	17
1920 .	—	—	—	—	0	6	4	4	2	16
1921 .	1	—	—	—	1	4	2	2	3	11
1922 .	1	—	—	—	1	4	—	4	3	11
1923 .	—	1	—	—	1	1	1	5	5	12
Totals .	2	6	4	3	15	24	15	19	20	78

In many of these cases a full discussion is given (in the *International Summary* itself) of the evidence for the hypothesis. Three principal points are generally examined with care.

(1) The time T_0 is shown to be well determined by the observations at a number of stations near the epicentre.

(2) The time of transmission to stations at the opposite side of the earth, as measured from this T_0 , is shown to differ sensibly from the average time, being less than the average when the focus is deep, greater when the focus is higher than normal.

(3) The observations at stations well distributed in azimuth round the epicentre are all shown to require correction of one sign, applied as corrections to Δ . The equations for correction to the position of the epicentre are usually solved both with and without the corrections to Δ , and it is shown that one solution will work, the other will not.

So far no other hypothesis has been put forward for the explanation of any of these $15+78=93$ anomalous cases. While it is not claimed that all of them are convincing in themselves, it is claimed that a large number require some special hypothesis for an adequate solution; and that when a single hypothesis satisfies them all, the cumulative evidence in favour of it is strong, and can only yield to some alternative which is equally or more successful.

Near Earthquakes.

By Dr. Harold Jeffreys.

When many good seismological stations exist within about 1000 km. of the epicentre of an earthquake their records can be used to give information about the upper layers of the earth's crust. It was discovered by A. Mohorovičić in 1909 that in such cases the records show not only the P and S of ordinary seismology, but also a pair of compressional and distortional waves that have travelled in an upper layer; their velocities are lower, but their amplitudes greater. Further work by Gutenberg, Conrad and the present writer has shown that three layers are really concerned, which probably correspond to the granitic, basaltic, and ultrabasic layers of geologists. The foci in all cases yet investigated have been in the uppermost, or granitic, layer. Two waves travel in this direct from the focus to the observing station; these are denoted by P_g and S_g , and their velocities are about 5.4 and 3.3 km./sec. Others called P^* and S^* seem to be transmitted down into the intermediate layer, travel along in this, and come up again to the surface. Their velocities in the intermediate layer are about 6.3 and 3.7 km./sec. Others go right down into the deepest layer. These are the ordinary P and S. Their velocities are 7.8 and 4.35 km./sec. Thus six distinct pulses are recognisable on the seismograms.

The times of transmission are linear functions of the epicentral distance, but the constant term is different for every wave, owing to the time spent in the upward and downward journey. The differences indicate that the granitic layer is about 10 km. and the intermediate one about 20 km. thick; these estimates agree with those made by other means.

The Jersey and Hereford earthquakes of 1926 have supplied much information in this work. Those used previously were all on the Continent of Europe.

The velocity of compressional waves in the uppermost layer agrees with that inferred for granite by L. H. Adams and E. D. Williamson from laboratory measures of its compressibility and density. That for the intermediate layer agrees with Adams's and Gibson's experimental value for tachylite, or vitreous basalt; and that for the lower layer with that of the same authors for dunite, an ultrabasic rock consisting mainly of olivine. Holmes has suggested the alternative succession granite-diorite-eclogite. The intermediate layer is not crystalline basalt; that would give a velocity of about 6.9 km./sec.

The observed times of the waves are in accordance with the laws of geometrical optics, but theory and observation both indicate that the amplitudes do not follow these laws, and that diffraction plays an important part. It affects the amplitudes but not the times of arrival.

The Palestine Earthquake.

The Palestine earthquake on July 11 must be classed as one of those which excite widespread interest and sympathy rather on account of the nature of the locality than because of special violence. Though undoubtedly disastrous, the intensity of the indications on the Oxford seismograms was far less than that of the China earthquake on May 22, at a far greater distance. The Acting High Commissioner for Palestine reported on July 18 [*The Times* of July 19] that in Palestine 200 people had been killed, 356 seriously injured, and 375 slightly injured. At a rough estimate 1000 houses were seriously damaged. In Transjordan 68 killed, 102 injured.

On July 22 and 23 there followed several shocks, one of them considerable, in Persia.

The British Earthquakes.

On 1926, August 15, one of the comparatively rare British earthquakes occurred near Hereford and Ludlow. On 1927, January 24, there was an earthquake in Scotland, and on 1927, February 17, there was one in Jersey. The Hereford and Jersey earthquakes have been carefully discussed by Dr. Harold Jeffreys as mentioned above.

Calculation of Mathematical Tables.—*Report of Committee* (Prof. J. W. NICHOLSON, *Chairman*; Dr. J. R. AIREY, *Secretary*; Dr. D. WRINCH-NICHOLSON, Mr. T. W. CHAUNDY, Dr. A. T. DOODSON, Prof. L. N. G. FILON, Dr. R. A. FISHER, Profs. E. W. HOBSON, ALFRED LODGE, A. E. H. LOVE, and H. M. MACDONALD).

REFERENCE was made in previous Reports to the desirability of publishing various tables of functions. The tables in this Report include the Confluent Hypergeometric Function, $M(\alpha, \gamma, x)$, $\gamma=1, 2, 3, 4$ and $\alpha=-4$ to $+4$ by 0.5 intervals and further values of the function for $\gamma=\pm\frac{1}{2}, \pm\frac{3}{2}$; the Exponential, Sine and Cosine Integrals, considerably extending the tables calculated by Dr. Glaisher (*Phil. Trans.*, 160, pp. 367-387, 1870); Zeros of Bessel functions of small fractional order and the Ber, Bei and other functions.

For next year it is proposed to publish tables of

(a) The Integral $I_0(x)=\int_x^\infty e^{-t^2} dt$ and functions derived by repeated integration of $I_0(x)$, x from 0.0 to 7.0 by 0.1 intervals to ten decimal places.

(b) The Derivatives of Bessel Functions, $\frac{\delta}{\delta\nu} J_\nu(x)$ and $\frac{\delta}{\delta\nu} J_{-\nu}(x)$, where $\nu = \frac{2n+1}{2}$ x from 0.0 to 10.0 by 0.1 intervals to six places of decimals.

(c) The first derivative of the Zonal Harmonics, $\frac{\delta}{\delta\theta} P_n(\cos\theta)$ for large values of the order, to six places of decimals. A table of $P_n(\cos\theta)$ to $P_{20}(\cos\theta)$ has been calculated by Prof. A. Lodge (*Phil. Trans.*, 203 A, 1904).

(d) The hyperbolic sines and cosines, $\text{Sinh } \pi x$ and $\text{Cosh } \pi x$, x from 0.0 to 4.0 by 0.01 intervals to fifteen places of decimals.

A list has been prepared of the tables which have appeared in the Reports of the Committee. The functions tabulated include the Circular and Hyperbolic functions, Gamma functions, the Exponential, Sine and Cosine Integrals, the Integrals of Fresnel, Zonal Harmonics, Riccati-Bessel functions, Bessel and other functions with real, imaginary and complex arguments, Lommel-Weber functions, and the Confluent Hypergeometric function. In a few cases prefatory notes to the tables give the properties of the functions and their applications to physical and engineering problems. Some tables from other sources are also included in the list. Before publishing in book form it will be necessary to rearrange the tables and remove a number of errors which have been discovered.

The Confluent Hypergeometric Function, $M(\alpha, \gamma, x)$.

In the construction of the tables for $\gamma=\pm\frac{1}{2}, \gamma=\pm\frac{3}{2}$, two calculations were made to ten decimal places for each value of the argument x , $M(-\frac{1}{2}, \frac{1}{2}, x)$ and $M(-\frac{3}{2}, \frac{1}{2}, x)$. Since $M(\frac{1}{2}, \frac{1}{2}, x)=e^x$, the three values could be checked by the recurrence formula,

$$\alpha M(\alpha+1, \gamma, x) = (x+2\alpha-\gamma)M(\alpha, \gamma, x) + (\gamma-\alpha)M(\alpha-1, \gamma, x).$$

The remaining values were obtained from the recurrence formulæ given in the introductory note to the tables published last year.

Similarly, when α is a positive integer, $M(1, \frac{1}{2}, x)$ and $M(1, \frac{3}{2}, x)$ were calculated for each value of x and the results checked by the formula

$$\frac{x}{\gamma} M(\alpha+1, \gamma+1, x) = M(\alpha+1, \gamma, x) - M(\alpha, \gamma, x).$$

The tables are a continuation of those given in last year's Report. Differential equations of the second order which can be solved in terms of the function $M(\alpha, \gamma, x)$ are also set out in the 1926 Report.

$M(\alpha \cdot \frac{1}{2} \cdot x)$

x	$\alpha=1$	$\alpha=2$	$\alpha=3$	$\alpha=4$
0.00	+ 1.00000	+ 1.00000	+ 1.00000	+ 1.00000
0.02	+ 1.04054	+ 1.08162	+ 1.12324	+ 1.16542
0.04	+ 1.08217	+ 1.16654	+ 1.25315	+ 1.34203
0.06	+ 1.12492	+ 1.25487	+ 1.38998	+ 1.53037
0.08	+ 1.16881	+ 1.34672	+ 1.53403	+ 1.73102
0.15	+ 1.33188	+ 1.69760	+ 2.09921	+ 2.53885
0.25	+ 1.59230	+ 2.28652	+ 3.09300	+ 4.02282
0.35	+ 1.88868	+ 2.99405	+ 4.34704	+ 5.98169
0.45	+ 2.22553	+ 3.83978	+ 5.91442	+ 8.53045
0.55	+ 2.60790	+ 4.84620	+ 7.85762	+ 11.8077
0.65	+ 3.04145	+ 6.03911	+ 10.2501	+ 15.9800
0.75	+ 3.53249	+ 7.44809	+ 13.1778	+ 21.2471
0.85	+ 4.08810	+ 9.10703	+ 16.7417	+ 27.8475
0.95	+ 4.71620	+ 11.0547	+ 21.0595	+ 36.0657
1.1	+ 5.81390	+ 14.6161	+ 29.2567	+ 52.1846
1.3	+ 7.62288	+ 20.8441	+ 44.3086	+ 83.0628
1.5	+ 9.91880	+ 29.2564	+ 65.7019	+ 128.924
1.7	+ 12.8255	+ 40.5417	+ 95.7892	+ 196.109
1.9	+ 16.4975	+ 55.5915	+ 137.724	+ 293.393

 $M(\alpha \cdot \frac{1}{2} \cdot x)$

x	$\alpha=-1$	$\alpha=-2$	$\alpha=-3$	$\alpha=-4$
0.00	+ 1.00000	+ 1.00000	+ 1.00000	+ 1.00000
0.02	+ 0.96000	+ 0.92053	+ 0.88160	+ 0.84318
0.04	+ 0.92000	+ 0.84213	+ 0.76637	+ 0.69266
0.06	+ 0.88000	+ 0.76480	+ 0.65428	+ 0.54834
0.08	+ 0.84000	+ 0.68853	+ 0.54533	+ 0.41011
0.15	+ 0.70000	+ 0.43000	+ 0.18820	+ 0.02712
0.25	+ 0.50000	+ 0.08333	- 0.25833	- 0.53274
0.35	+ 0.30000	- 0.23667	- 0.63287	- 0.90918
0.45	+ 0.10000	- 0.53000	- 0.93860	- 1.16815
0.55	- 0.10000	- 0.79667	- 1.17873	- 1.32099
0.65	- 0.30000	- 1.03667	- 1.35647	- 1.37867
0.75	- 0.50000	- 1.25000	- 1.47500	- 1.35179
0.85	- 0.70000	- 1.43667	- 1.53753	- 1.25059
0.95	- 0.90000	- 1.59667	- 1.54727	- 1.08305
1.1	- 1.20000	- 1.78667	- 1.46987	- 0.73637
1.3	- 1.60000	- 1.94667	- 1.21173	- 0.13172
1.5	- 2.00000	- 2.00000	- 0.80000	- 0.57143
1.7	- 2.40000	- 1.94667	- 0.26027	+ 1.31163
1.9	- 2.80000	- 1.78667	- 0.38187	+ 2.03331

M ($\alpha \cdot \frac{1}{2} \cdot x$)

x	$\alpha = \frac{1}{2}$	$\alpha = \frac{3}{2}$	$\alpha = \frac{5}{2}$	$\alpha = \frac{7}{2}$
0.00	+ 1.00000	+ 1.00000	+ 1.00000	+ 1.00000
0.02	+ 1.02020	+ 1.06101	+ 1.10236	+ 1.14426
0.04	+ 1.04081	+ 1.12408	+ 1.20956	+ 1.29730
0.06	+ 1.06184	+ 1.18926	+ 1.32177	+ 1.45951
0.08	+ 1.08329	+ 1.25661	+ 1.43918	+ 1.63129
0.15	+ 1.16183	+ 1.51038	+ 1.89379	+ 2.31414
0.25	+ 1.28403	+ 1.92604	+ 2.67505	+ 3.54177
0.35	+ 1.41907	+ 2.41241	+ 3.63754	+ 5.12690
0.45	+ 1.56831	+ 2.97979	+ 4.81472	+ 7.14931
0.55	+ 1.73325	+ 3.63983	+ 6.24549	+ 9.70402
0.65	+ 1.91554	+ 4.40574	+ 7.97503	+ 12.9040
0.75	+ 2.11700	+ 5.29250	+ 10.0558	+ 16.8831
0.85	+ 2.33965	+ 6.31705	+ 12.5483	+ 21.7997
0.95	+ 2.58571	+ 7.49856	+ 15.5229	+ 27.8410
1.1	+ 3.00417	+ 9.61333	+ 21.0692	+ 39.5044
1.3	+ 3.66930	+ 13.2095	+ 31.0178	+ 61.3937
1.5	+ 4.48169	+ 17.9268	+ 44.8169	+ 93.2191
1.7	+ 5.47395	+ 24.0854	+ 63.7897	+ 138.930
1.9	+ 6.68589	+ 32.0923	+ 89.6801	+ 203.907

M ($\alpha \cdot \frac{1}{2} \cdot x$)

x	$\alpha = -\frac{1}{2}$	$\alpha = -\frac{3}{2}$	$\alpha = -\frac{5}{2}$	$\alpha = -\frac{7}{2}$
0.00	+ 1.00000	+ 1.00000	+ 1.00000	+ 1.00000
0.02	+ 0.97993	+ 0.94020	+ 0.90100	+ 0.86232
0.04	+ 0.95973	+ 0.88080	+ 0.80399	+ 0.72926
0.06	+ 0.93939	+ 0.82181	+ 0.70896	+ 0.60075
0.08	+ 0.91892	+ 0.76322	+ 0.61591	+ 0.47674
0.15	+ 0.84613	+ 0.56136	+ 0.30568	+ 0.07733
0.25	+ 0.73904	+ 0.28179	- 0.09638	- 0.40348
0.35	+ 0.62806	+ 0.01273	- 0.45099	- 0.78481
0.45	+ 0.51295	- 0.24556	- 0.75919	- 1.07334
0.55	+ 0.39344	- 0.49286	- 1.02204	- 1.27566
0.65	+ 0.26925	- 0.72891	- 1.24063	- 1.39826
0.75	+ 0.14006	- 0.95346	- 1.41605	- 1.44753
0.85	+ 0.00554	- 1.16622	- 1.54940	- 1.42972
0.95	- 0.13467	- 1.36692	- 1.64183	- 1.28767
1.1	- 0.35650	- 1.64468	- 1.70625	- 1.13193
1.3	- 0.67606	- 1.96986	- 1.65980	- 0.68217
1.5	- 1.02641	- 2.24084	- 1.47103	- 0.09401
1.7	- 1.41211	- 2.45455	- 1.15002	+ 0.58877
1.9	- 1.83845	- 2.60757	- 0.70722	+ 1.32431

$M(\alpha \cdot \frac{3}{2} \cdot x)$

x	$\alpha=1$	$\alpha=2$	$\alpha=3$	$\alpha=4$
0.00	+ 1.00000	+ 1.00000	+ 1.00000	+ 1.00000
0.02	+ 1.01344	+ 1.02699	+ 1.04065	+ 1.05441
0.04	+ 1.02710	+ 1.05463	+ 1.08261	+ 1.11103
0.06	+ 1.04098	+ 1.08295	+ 1.12593	+ 1.16994
0.08	+ 1.05508	+ 1.11195	+ 1.17064	+ 1.23121
0.15	+ 1.10627	+ 1.21907	+ 1.33871	+ 1.46546
0.25	+ 1.18459	+ 1.38844	+ 1.61296	+ 1.85964
0.35	+ 1.26954	+ 1.57911	+ 1.93284	+ 2.33521
0.45	+ 1.36170	+ 1.79361	+ 2.30515	+ 2.90670
0.55	+ 1.46173	+ 2.03481	+ 2.73766	+ 3.59099
0.65	+ 1.57034	+ 2.30589	+ 3.23920	+ 4.40767
0.75	+ 1.68832	+ 2.61041	+ 3.81983	+ 5.37950
0.85	+ 1.81653	+ 2.95231	+ 4.49100	+ 6.53278
0.95	+ 1.95589	+ 3.33605	+ 5.26571	+ 7.89801
1.1	+ 2.18814	+ 4.00102	+ 6.65480	+ 10.4218
1.3	+ 2.54726	+ 5.08507	+ 9.02482	+ 14.9055
1.5	+ 2.97293	+ 6.44587	+ 12.1485	+ 21.0741
1.7	+ 3.47810	+ 8.15181	+ 16.2493	+ 29.5059
1.9	+ 4.07829	+ 10.2879	+ 21.6138	+ 40.9655

 $M(\alpha \cdot \frac{3}{2} \cdot x)$

x	$\alpha=-1$	$\alpha=-2$	$\alpha=-3$	$\alpha=-4$
0.00	+ 1.00000	+ 1.00000	+ 1.00000	+ 1.00000
0.02	+ 0.98667	+ 0.97344	+ 0.96032	+ 0.94730
0.04	+ 0.97333	+ 0.94709	+ 0.92128	+ 0.89587
0.06	+ 0.96000	+ 0.92096	+ 0.88286	+ 0.84569
0.08	+ 0.94667	+ 0.89504	+ 0.84508	+ 0.79675
0.15	+ 0.90000	+ 0.80600	+ 0.71774	+ 0.63498
0.25	+ 0.83333	+ 0.68333	+ 0.54881	+ 0.42864
0.35	+ 0.76667	+ 0.56600	+ 0.39473	+ 0.24985
0.45	+ 0.70000	+ 0.45400	+ 0.25506	+ 0.09692
0.55	+ 0.63333	+ 0.34733	+ 0.12932	- 0.03182
0.65	+ 0.56667	+ 0.24600	+ 0.01708	- 0.13801
0.75	+ 0.50000	+ 0.15000	- 0.08214	- 0.22321
0.85	+ 0.43333	+ 0.05933	- 0.16879	- 0.28899
0.95	+ 0.36667	- 0.02600	- 0.24432	- 0.33752
1.1	+ 0.26667	- 0.14400	- 0.33341	- 0.37818
1.3	+ 0.13333	- 0.28267	- 0.41539	- 0.38387
1.5	+ 0.00000	- 0.40000	- 0.45714	- 0.34286
1.7	- 0.13333	- 0.49600	- 0.46232	- 0.26522
1.9	- 0.26667	- 0.57067	- 0.43459	- 0.16038

M ($\alpha . \frac{3}{2} . x$)

x	$\alpha = \frac{1}{2}$	$\alpha = \frac{3}{2}$	$\alpha = \frac{5}{2}$	$\alpha = \frac{7}{2}$
0.00	+ 1.00000	+ 1.00000	+ 1.00000	+ 1.00000
0.02	+ 1.00671	+ 1.02020	+ 1.03380	+ 1.04752
0.04	+ 1.01349	+ 1.04081	+ 1.06857	+ 1.09676
0.06	+ 1.02037	+ 1.06184	+ 1.10431	+ 1.14780
0.08	+ 1.02732	+ 1.08329	+ 1.14106	+ 1.20069
0.15	+ 1.05233	+ 1.16183	+ 1.27802	+ 1.40117
0.25	+ 1.08997	+ 1.28403	+ 1.49803	+ 1.73343
0.35	+ 1.13001	+ 1.41907	+ 1.75018	+ 2.12765
0.45	+ 1.17262	+ 1.56831	+ 2.03881	+ 2.59399
0.55	+ 1.21801	+ 1.73325	+ 2.36878	+ 3.14412
0.65	+ 1.26638	+ 1.91554	+ 2.74561	+ 3.79149
0.75	+ 1.31796	+ 2.11700	+ 3.17550	+ 4.55155
0.85	+ 1.37300	+ 2.33965	+ 3.66545	+ 5.44202
0.95	+ 1.43178	+ 2.58571	+ 4.22333	+ 6.48324
1.1	+ 1.52757	+ 3.00417	+ 5.20722	+ 8.37962
1.3	+ 1.67129	+ 3.66930	+ 6.84935	+ 11.6830
1.5	+ 1.83603	+ 4.48169	+ 8.96338	+ 16.1341
1.7	+ 2.02531	+ 5.47395	+ 11.6778	+ 22.1002
1.9	+ 2.24325	+ 6.68589	+ 15.1547	+ 30.0598

M ($\alpha . \frac{3}{2} . x$)

x	$\alpha = -\frac{1}{2}$	$\alpha = -\frac{3}{2}$	$\alpha = -\frac{5}{2}$	$\alpha = -\frac{7}{2}$
0.00	+ 1.00000	+ 1.00000	+ 1.00000	+ 1.00000
0.02	+ 0.99332	+ 0.98004	+ 0.96687	+ 0.95380
0.04	+ 0.98661	+ 0.96016	+ 0.93413	+ 0.90852
0.06	+ 0.97988	+ 0.94036	+ 0.90179	+ 0.86416
0.08	+ 0.97312	+ 0.92064	+ 0.86985	+ 0.82071
0.15	+ 0.94923	+ 0.85227	+ 0.76117	+ 0.67569
0.25	+ 0.91451	+ 0.75633	+ 0.61421	+ 0.48700
0.35	+ 0.87904	+ 0.66246	+ 0.47689	+ 0.31917
0.45	+ 0.84279	+ 0.57070	+ 0.34905	+ 0.17125
0.55	+ 0.80573	+ 0.48108	+ 0.23056	+ 0.04228
0.65	+ 0.76781	+ 0.39363	+ 0.12126	- 0.06868
0.75	+ 0.72901	+ 0.30839	+ 0.02099	- 0.16258
0.85	+ 0.68927	+ 0.22540	- 0.07040	- 0.24032
0.95	+ 0.64856	+ 0.14469	- 0.18640	- 0.32406
1.1	+ 0.58554	+ 0.02798	- 0.26105	- 0.36991
1.3	+ 0.49762	- 0.11925	- 0.37601	- 0.41428
1.5	+ 0.40481	- 0.25660	- 0.45901	- 0.41338
1.7	+ 0.30660	- 0.38369	- 0.51141	- 0.37389
1.9	+ 0.20240	- 0.50009	- 0.53461	- 0.30225

$M(\alpha. - \frac{1}{2}. x)$

x	$\alpha=1$	$\alpha=2$	$\alpha=3$	$\alpha=4$
0.00	+ 1.00000	+ 1.00000	+ 1.00000	+ 1.00000
0.02	+ 0.95838	+ 0.91511	+ 0.87018	+ 0.82357
0.04	+ 0.91343	+ 0.82010	+ 0.71985	+ 0.61249
0.06	+ 0.86501	+ 0.71443	+ 0.54763	+ 0.36398
0.08	+ 0.81299	+ 0.59751	+ 0.35207	+ 0.07511
0.15	+ 0.60044	+ 0.09116	- 0.53861	- 1.30026
0.25	+ 0.20385	- 0.93941	- 2.48591	- 4.49732
0.35	- 0.32207	- 2.41791	- 5.46084	- 9.64802
0.45	- 1.00298	- 4.45878	- 9.78176	- 17.4592
0.55	- 1.86869	- 7.19951	- 15.8429	- 28.8314
0.65	- 2.95388	- 10.8047	- 24.1298	- 44.9039
0.75	- 4.29873	- 15.4709	- 35.2376	- 67.1082
0.85	- 5.94977	- 21.4317	- 49.8927	- 97.2333
0.95	- 7.96078	- 28.9647	- 68.9778	- 137.503
1.1	-11.7906	- 43.9461	-108.311	- 223.117
1.3	-18.8195	- 73.0141	-188.217	- 404.180
1.5	-28.7564	-116.526	-313.631	- 700.403
1.7	-42.6068	-180.448	-506.132	-1172.90
1.9	-61.6905	-272.938	-796.289	-1911.18

$M(\alpha. - \frac{1}{2}. x)$

x	$\alpha=-1$	$\alpha=-2$	$\alpha=-3$	$\alpha=-4$
0.00	+ 1.00000	+ 1.00000	+ 1.00000	+ 1.00000
0.02	+ 1.04000	+ 1.07840	+ 1.11522	+ 1.15049
0.04	+ 1.08000	+ 1.15360	+ 1.22097	+ 1.28228
0.06	+ 1.12000	+ 1.22560	+ 1.31738	+ 1.39589
0.08	+ 1.16000	+ 1.29440	+ 1.40457	+ 1.49182
0.15	+ 1.30000	+ 1.51000	+ 1.63900	+ 1.69546
0.25	+ 1.50000	+ 1.75000	+ 1.79167	+ 1.66250
0.35	+ 1.70000	+ 1.91000	+ 1.74433	+ 1.30133
0.45	+ 1.90000	+ 1.99000	+ 1.51300	+ 0.66826
0.55	+ 2.10000	+ 1.99000	+ 1.11367	- 0.18294
0.65	+ 2.30000	+ 1.91000	+ 0.56233	- 1.20107
0.75	+ 2.50000	+ 1.75000	- 0.12500	- 2.33750
0.85	+ 2.70000	+ 1.51000	- 0.93233	- 3.54614
0.95	+ 2.90000	+ 1.19000	- 1.84367	- 4.78347
1.1	+ 3.20000	+ 0.56000	- 3.37067	- 6.60437
1.3	+ 3.60000	- 0.56000	- 5.62133	- 8.77184
1.5	+ 4.00000	- 2.00000	- 8.00000	-10.4000
1.7	+ 4.40000	- 3.76000	-10.3787	-11.2636
1.9	+ 4.80000	- 5.84000	-12.6293	-11.1782

$M(\alpha . - \frac{1}{2} . x)$

x	$\alpha = \frac{1}{2}$	$\alpha = \frac{3}{2}$	$\alpha = \frac{5}{2}$	$\alpha = \frac{7}{2}$
0.00	+ 1.00000	+ 1.00000	+ 1.00000	+ 1.00000
0.02	+ 0.97939	+ 0.93695	+ 0.89286	+ 0.84709
0.04	+ 0.95755	+ 0.86762	+ 0.77085	+ 0.66707
0.06	+ 0.93442	+ 0.79171	+ 0.63309	+ 0.45795
0.08	+ 0.90996	+ 0.70890	+ 0.47863	+ 0.21763
0.15	+ 0.81328	+ 0.36017	- 0.20797	- 0.90221
0.25	+ 0.64201	- 0.32101	- 1.65853	- 3.42942
0.35	+ 0.42572	- 1.26297	- 3.80925	- 7.39808
0.45	+ 0.15683	- 2.52498	- 6.85823	- 13.2926
0.55	- 0.17333	- 4.17714	- 11.0472	- 21.7216
0.65	- 0.57466	- 6.30213	- 16.6697	- 33.4448
0.75	- 1.05850	- 8.99725	- 24.0809	- 49.4055
0.85	- 1.63775	- 12.3767	- 33.7089	- 70.7684
0.95	- 2.32714	- 16.5744	- 46.0679	- 98.9658
1.1	- 3.60500	- 24.7543	- 71.1066	- 158.016
1.3	- 5.87087	- 40.2155	- 120.862	- 280.485
1.5	- 8.96338	- 62.7436	- 197.194	- 476.852
1.7	- 13.1375	- 95.0277	- 311.913	- 784.276
1.9	- 18.7205	- 140.671	- 481.456	- 1256.30

$M(\alpha . - \frac{1}{2} . x)$

x	$\alpha = -\frac{1}{2}$	$\alpha = -\frac{3}{2}$	$\alpha = -\frac{5}{2}$	$\alpha = -\frac{7}{2}$
0.00	+ 1.00000	+ 1.00000	+ 1.00000	+ 1.00000
0.02	+ 1.02020	+ 1.05940	+ 1.09701	+ 1.13305
0.04	+ 1.04081	+ 1.11759	+ 1.18805	+ 1.25237
0.06	+ 1.06184	+ 1.17456	+ 1.27318	+ 1.35826
0.08	+ 1.08329	+ 1.23031	+ 1.35243	+ 1.45097
0.15	+ 1.16183	+ 1.41567	+ 1.58408	+ 1.67579
0.25	+ 1.28403	+ 1.65354	+ 1.79444	+ 1.74625
0.35	+ 1.41907	+ 1.85871	+ 1.86762	+ 1.55193
0.45	+ 1.56831	+ 2.02997	+ 1.80896	+ 1.12569
0.55	+ 1.73325	+ 2.16604	+ 1.62390	+ 0.49965
0.65	+ 1.91554	+ 2.26556	+ 1.31798	- 0.29484
0.75	+ 2.11700	+ 2.32709	+ 0.89691	- 1.22716
0.85	+ 2.33965	+ 2.34907	+ 0.36649	- 2.26749
0.95	+ 2.58571	+ 2.32985	- 0.26730	- 3.38678
1.1	+ 3.00417	+ 2.21987	- 1.39843	- 5.15217
1.3	+ 3.66930	+ 1.91154	- 3.21009	- 7.52558
1.5	+ 4.48169	+ 1.40245	- 5.32009	- 9.73319
1.7	+ 5.47395	+ 0.67278	- 7.67269	- 11.5828
1.9	+ 6.68589	- 0.30020	- 10.2090	- 12.8964

$M(\alpha . - \frac{1}{2} . x)$

x	$\alpha=1$	$\alpha=2$	$\alpha=3$	$\alpha=4$
0.00	+ 1.00000	+ 1.00000	+ 1.00000	+ 1.00000
0.02	+ 0.98722	+ 0.97502	+ 0.96342	+ 0.95244
0.04	+ 0.97564	+ 0.95377	+ 0.93458	+ 0.91824
0.06	+ 0.96540	+ 0.93682	+ 0.91492	+ 0.90036
0.08	+ 0.95664	+ 0.92477	+ 0.90600	+ 0.90199
0.15	+ 0.93996	+ 0.93084	+ 0.98470	+ 1.11473
0.25	+ 0.96602	+ 1.12259	+ 1.53691	+ 2.28646
0.35	+ 1.07515	+ 1.63933	+ 2.91353	+ 5.16473
0.45	+ 1.30089	+ 2.63853	+ 5.57305	+ 10.8108
0.55	+ 1.68519	+ 4.32501	+ 10.1341	+ 20.7056
0.65	+ 2.28001	+ 6.96206	+ 17.4183	+ 36.8766
0.75	+ 3.14936	+ 10.8848	+ 28.5036	+ 62.0577
0.85	+ 4.37154	+ 16.5162	+ 44.7887	+ 99.8876
0.95	+ 6.04183	+ 24.3861	+ 68.0721	+ 155.157
1.1	+ 9.64643	+ 41.8736	+ 121.301	+ 284.921
1.3	+ 17.3102	+ 80.5891	+ 243.710	+ 593.999
1.5	+ 29.7564	+ 146.282	+ 459.913	+ 1160.32
1.7	+ 49.2877	+ 253.796	+ 827.412	+ 2156.70
1.9	+ 79.1413	+ 424.863	+ 1433.50	+ 3854.33

 $M(\alpha . - \frac{3}{2} . x)$

x	$\alpha=-1$	$\alpha=-2$	$\alpha=-3$	$\alpha=-4$
0.00	+ 1.00000	+ 1.00000	+ 1.00000	+ 1.00000
0.02	+ 1.01333	+ 1.02720	+ 1.04158	+ 1.05645
0.04	+ 1.02667	+ 1.05547	+ 1.08623	+ 1.11879
0.06	+ 1.04000	+ 1.08480	+ 1.13382	+ 1.18652
0.08	+ 1.05333	+ 1.11520	+ 1.18423	+ 1.25914
0.15	+ 1.10000	+ 1.23000	+ 1.38100	+ 1.54490
0.25	+ 1.16667	+ 1.41667	+ 1.70833	+ 2.00694
0.35	+ 1.23333	+ 1.63000	+ 2.07567	+ 2.48268
0.45	+ 1.30000	+ 1.87000	+ 2.46700	+ 2.92090
0.55	+ 1.36667	+ 2.13667	+ 2.86633	+ 3.27468
0.65	+ 1.43333	+ 2.43000	+ 3.25767	+ 3.50134
0.75	+ 1.50000	+ 2.75000	+ 3.62500	+ 3.56250
0.85	+ 1.56667	+ 3.09667	+ 3.95233	+ 3.42401
0.95	+ 1.63333	+ 3.47000	+ 4.22367	+ 3.05601
1.1	+ 1.73333	+ 4.08000	+ 4.49067	+ 2.01884
1.3	+ 1.86667	+ 4.98667	+ 4.50133	- 0.37049
1.5	+ 2.00000	+ 6.00000	+ 4.00000	- 4.00000
1.7	+ 2.13333	+ 7.12000	+ 2.85867	- 8.90382
1.9	+ 2.26667	+ 8.34667	+ 0.94933	- 15.0478

$M(\alpha . - \frac{\alpha}{2} . x)$

x	$\alpha = \frac{1}{2}$	$\alpha = \frac{3}{2}$	$\alpha = \frac{5}{2}$	$\alpha = \frac{7}{2}$
0.00	+ 1.00000	+ 1.00000	+ 1.00000	+ 1.00000
0.02	+ 0.99354	+ 0.98105	+ 0.96914	+ 0.95785
0.04	+ 0.98752	+ 0.96438	+ 0.94383	+ 0.92604
0.06	+ 0.98199	+ 0.95032	+ 0.92499	+ 0.90668
0.08	+ 0.97698	+ 0.93917	+ 0.91365	+ 0.90204
0.15	+ 0.96432	+ 0.92831	+ 0.94910	+ 1.03932
0.25	+ 0.96302	+ 1.01652	+ 1.29294	+ 1.86451
0.35	+ 0.98862	+ 1.28331	+ 2.17213	+ 3.89835
0.45	+ 1.05077	+ 1.80826	+ 3.86573	+ 7.85351
0.55	+ 1.16128	+ 2.69290	+ 6.74353	+ 14.7081
0.65	+ 1.33449	+ 4.06542	+ 11.2889	+ 25.7817
0.75	+ 1.58775	+ 6.08638	+ 18.1268	+ 42.8296
0.85	+ 1.94191	+ 8.95539	+ 28.0571	+ 68.1591
0.95	+ 2.42195	+ 12.9191	+ 42.0954	+ 104.774
1.1	+ 3.44478	+ 21.5980	+ 73.7428	+ 189.621
1.3	+ 5.57733	+ 40.4308	+ 145.178	+ 388.265
1.5	+ 8.96338	+ 71.7070	+ 268.901	+ 745.753
1.7	+ 14.1593	+ 121.857	+ 475.359	+ 1364.20
1.9	+ 21.9297	+ 200.113	+ 809.957	+ 2401.27

$M(\alpha . - \frac{3}{2} . x)$

x	$\alpha = -\frac{1}{2}$	$\alpha = -\frac{3}{2}$	$\alpha = -\frac{5}{2}$	$\alpha = -\frac{7}{2}$
0.00	+ 1.00000	+ 1.00000	+ 1.00000	+ 1.00000
0.02	+ 1.00660	+ 1.02020	+ 1.03433	+ 1.04895
0.04	+ 1.01306	+ 1.04081	+ 1.07061	+ 1.10229
0.06	+ 1.01936	+ 1.06184	+ 1.10882	+ 1.15975
0.08	+ 1.02551	+ 1.08329	+ 1.14890	+ 1.22103
0.15	+ 1.04565	+ 1.16183	+ 1.30340	+ 1.46181
0.25	+ 1.07002	+ 1.28403	+ 1.55962	+ 1.85869
0.35	+ 1.08795	+ 1.41907	+ 1.85277	+ 2.28855
0.45	+ 1.09782	+ 1.56831	+ 2.17730	+ 2.71999
0.55	+ 1.09773	+ 1.73325	+ 2.52747	+ 3.12290
0.65	+ 1.08547	+ 1.91554	+ 2.89729	+ 3.46841
0.75	+ 1.05850	+ 2.11700	+ 3.28054	+ 3.72900
0.85	+ 1.01385	+ 2.33965	+ 3.67079	+ 3.87846
0.95	+ 0.94809	+ 2.58571	+ 4.06128	+ 3.89199
1.1	+ 0.80111	+ 3.00417	+ 4.63207	+ 3.60656
1.3	+ 0.48924	+ 3.66930	+ 5.32597	+ 2.54389
1.5	+ 0.00000	+ 4.48169	+ 5.88414	+ 0.56405
1.7	- 0.72986	+ 5.47395	+ 6.23644	- 2.45928
1.9	- 1.78291	+ 6.68589	+ 6.30564	- 6.62572

To construct the table of $M(\alpha . \gamma . x)$ when α and γ are positive integers, two values of the function for each value of x are required, $M(0 . 1 . x) = 1$ and $M(1 . 1 . x) = e^x$. The remaining entries to ten significant figures were calculated as before from the various recurrence formulæ. When $\alpha = \pm \frac{1}{2}, \pm \frac{3}{2}$, the independent calculations of $M(\frac{1}{2} . 1 . x)$ and $M(-\frac{1}{2} . 1 . x)$ were checked from the tables* of $I_0(x)$ and $I_1(x)$.

* A. Lodge. Reports of the Committee, 1893 and 1896.

* Aldis. Proc. Roy. Society, 64, 1899.

When $\alpha = \frac{\gamma}{2}$, $M(\alpha, \gamma, x)$ can be expressed in terms of these Bessel functions of imaginary argument :

$$M\left(\frac{1}{2}, 1, x\right) = e^x I_0\left(\frac{x}{2}\right) \text{ and}$$

$$M\left(\frac{3}{2}, 3, x\right) = \frac{4}{x} \cdot e^x \cdot I_1\left(\frac{x}{2}\right).$$

$$M(\alpha, 1, x)$$

x	$\alpha=1$		$\alpha=2$		$\alpha=3$		$\alpha=4$	
0.00	+	1.00000	+	1.00000	+	1.00000	+	1.00000
0.02	+	1.02020	+	1.04061	+	1.06121	+	1.08203
0.04	+	1.04081	+	1.08244	+	1.12491	+	1.16822
0.06	+	1.06184	+	1.12555	+	1.19117	+	1.25874
0.08	+	1.08329	+	1.16995	+	1.26008	+	1.35377
0.10	+	1.10517	+	1.21569	+	1.33173	+	1.45348
0.15	+	1.16183	+	1.33611	+	1.52346	+	1.72453
0.20	+	1.22140	+	1.46568	+	1.73439	+	2.02916
0.25	+	1.28403	+	1.60503	+	1.96616	+	2.37077
0.30	+	1.34986	+	1.75482	+	2.22052	+	2.75304
0.35	+	1.41907	+	1.91574	+	2.49933	+	3.17998
0.40	+	1.49182	+	2.08855	+	2.80463	+	3.65597
0.45	+	1.56831	+	2.27405	+	3.13858	+	4.18573
0.50	+	1.64872	+	2.47308	+	3.50353	+	4.77442
0.55	+	1.73325	+	2.68654	+	3.90199	+	5.42765
0.60	+	1.82212	+	2.91539	+	4.33664	+	6.15147
0.65	+	1.91554	+	3.16064	+	4.81040	+	6.95250
0.70	+	2.01375	+	3.42338	+	5.32638	+	7.83786
0.75	+	2.11700	+	3.70475	+	5.88791	+	8.81532
0.80	+	2.22554	+	4.00597	+	6.49858	+	9.89327
0.85	+	2.33965	+	4.32835	+	7.16224	+	11.0808
0.90	+	2.45960	+	4.67325	+	7.88303	+	12.3878
0.95	+	2.58571	+	5.04213	+	8.66536	+	13.8249
1.0	+	2.71828	+	5.43656	+	9.51399	+	15.4036
1.1	+	3.00417	+	6.30875	+	11.4309	+	19.0369
1.2	+	3.32012	+	7.30426	+	13.6789	+	23.4002
1.3	+	3.66930	+	8.43938	+	16.3100	+	28.6248
1.4	+	4.05520	+	9.73248	+	19.3839	+	34.8639
1.5	+	4.48169	+	11.2042	+	22.9687	+	42.2959
1.6	+	4.95303	+	12.8779	+	27.1426	+	51.1285
1.7	+	5.47395	+	14.7797	+	31.9952	+	61.6029
1.8	+	6.04965	+	16.9390	+	37.6288	+	73.9993
1.9	+	6.68589	+	19.3891	+	44.1603	+	88.6427
2.0	+	7.38906	+	22.1672	+	51.7234	+	105.910
2.2	+	9.02501	+	28.8800	+	70.5756	+	150.128
2.4	+	11.0232	+	37.4788	+	95.6812	+	211.028
2.6	+	13.4637	+	48.4695	+	128.983	+	294.443
2.8	+	16.4446	+	62.4897	+	172.998	+	408.134
3.0	+	20.0855	+	80.3421	+	230.984	+	562.395
3.5	+	33.1155	+	149.020	+	467.756	+	1225.96
4.0	+	54.5982	+	272.991	+	928.169	+	2602.51
4.5	+	90.0171	+	495.094	+	1811.59	+	5406.65
5.0	+	148.413	+	890.479	+	3487.71	+	11032.0
5.5	+	244.692	+	1590.50	+	6637.27	+	22170.1
6.0	+	403.429	+	2824.00	+	12506.3	+	43973.7
6.5	+	665.142	+	4988.56	+	23363.1	+	86232.8
7.0	+	1096.63	+	8773.07	+	43317.0	+	167419.3
7.5	+	1808.04	+	15368.4	+	79779.9	+	322170.6
8.0	+	2980.96	+	26828.6	+	146067.0	+	615071.0

M ($\alpha . 1 . x$)

x	$\alpha = -1$	$\alpha = -2$	$\alpha = -3$	$\alpha = -4$
0.00	+ 1.00000	+ 1.00000	+ 1.00000	+ 1.00000
0.02	+ 0.98000	+ 0.96020	+ 0.94060	+ 0.92119
0.04	+ 0.96000	+ 0.92080	+ 0.88239	+ 0.84476
0.06	+ 0.94000	+ 0.88180	+ 0.82536	+ 0.77066
0.08	+ 0.92000	+ 0.84320	+ 0.76951	+ 0.69886
0.10	+ 0.90000	+ 0.80500	+ 0.71483	+ 0.67066
0.15	+ 0.85000	+ 0.71125	+ 0.58319	+ 0.46527
0.20	+ 0.80000	+ 0.62000	+ 0.45867	+ 0.31473
0.25	+ 0.75000	+ 0.53125	+ 0.34415	+ 0.17725
0.30	+ 0.70000	+ 0.44500	+ 0.23050	+ 0.05234
0.35	+ 0.65000	+ 0.36125	+ 0.12660	- 0.06046
0.40	+ 0.60000	+ 0.28000	+ 0.02933	- 0.16160
0.45	+ 0.55000	+ 0.20125	- 0.06144	- 0.25154
0.50	+ 0.50000	+ 0.12500	- 0.14583	- 0.33073
0.55	+ 0.45000	+ 0.05125	- 0.22398	- 0.39960
0.60	+ 0.40000	- 0.02000	- 0.29600	- 0.45860
0.65	+ 0.35000	- 0.08875	- 0.36202	- 0.50815
0.70	+ 0.30000	- 0.15500	- 0.42217	- 0.54866
0.75	+ 0.25000	- 0.21875	- 0.47656	- 0.58057
0.80	+ 0.20000	- 0.28000	- 0.52533	- 0.60427
0.85	+ 0.15000	- 0.33875	- 0.56860	- 0.62017
0.90	+ 0.10000	- 0.39500	- 0.60650	- 0.62866
0.95	+ 0.05000	- 0.44875	- 0.63915	- 0.63015
1.0	- 0.00000	- 0.50000	- 0.66667	- 0.62500
1.1	- 0.10000	- 0.59500	- 0.70683	- 0.59633
1.2	- 0.20000	- 0.68000	- 0.72800	- 0.54560
1.3	- 0.30000	- 0.75500	- 0.73117	- 0.47566
1.4	- 0.40000	- 0.82000	- 0.71733	- 0.38927
1.5	- 0.50000	- 0.87500	- 0.68750	- 0.28906
1.6	- 0.60000	- 0.92000	- 0.64267	- 0.17760
1.7	- 0.70000	- 0.95500	- 0.58383	- 0.05733
1.8	- 0.80000	- 0.98000	- 0.51200	+ 0.06940
1.9	- 0.90000	- 0.99500	- 0.42817	+ 0.20034
2.0	- 1.00000	- 1.00000	- 0.33333	+ 0.33333
2.2	- 1.20000	- 0.98000	- 0.11467	+ 0.59740
2.4	- 1.40000	- 0.92000	+ 0.13600	+ 0.84640
2.6	- 1.60000	- 0.82000	+ 0.41067	+ 1.06673
2.8	- 1.80000	- 0.68000	+ 0.70133	+ 1.24640
3.0	- 2.00000	- 0.50000	+ 1.00000	+ 1.37500
3.5	- 2.50000	+ 0.12500	+ 1.72917	+ 1.41927
4.0	- 3.00000	+ 1.00000	+ 2.33333	+ 1.00000
4.5	- 3.50000	+ 2.12500	+ 2.68750	+ 0.08594
5.0	- 4.00000	+ 3.50000	+ 2.66667	- 1.29167
5.5	- 4.50000	+ 5.12500	+ 2.14583	- 3.03906
6.0	- 5.00000	+ 7.00000	+ 1.00000	- 5.00000
6.5	- 5.50000	+ 9.12500	- 0.89583	- 6.95573
7.0	- 6.00000	+ 11.50000	- 3.66667	- 8.62500
7.5	- 6.50000	+ 14.12500	- 7.43750	- 9.66406
8.0	- 7.00000	+ 17.00000	- 12.33333	- 9.66667

M ($\alpha . 1 . x$)

x	$\alpha = \frac{1}{2}$	$\alpha = \frac{3}{2}$	$\alpha = \frac{5}{2}$	$\alpha = \frac{7}{2}$
0.00	+ 1.00000	+ 1.00000	+ 1.00000	+ 1.00000
0.02	+ 1.01008	+ 1.03038	+ 1.05088	+ 1.07159
0.04	+ 1.02030	+ 1.06152	+ 1.10357	+ 1.14646
0.06	+ 1.03069	+ 1.09346	+ 1.15812	+ 1.22471
0.08	+ 1.04123	+ 1.12619	+ 1.21458	+ 1.30647
0.10	+ 1.05193	+ 1.15975	+ 1.27301	+ 1.39188
0.15	+ 1.07940	+ 1.24738	+ 1.42811	+ 1.62223
0.20	+ 1.10794	+ 1.34059	+ 1.59688	+ 1.87841
0.25	+ 1.13758	+ 1.43971	+ 1.78038	+ 2.16281
0.30	+ 1.16838	+ 1.54511	+ 1.97970	+ 2.47803
0.35	+ 1.20038	+ 1.65714	+ 2.19606	+ 2.82686
0.40	+ 1.23365	+ 1.77621	+ 2.43072	+ 3.21234
0.45	+ 1.26822	+ 1.90272	+ 2.68504	+ 3.63774
0.50	+ 1.30417	+ 2.03713	+ 2.96050	+ 4.10661
0.55	+ 1.34154	+ 2.17989	+ 3.25864	+ 4.62278
0.60	+ 1.38040	+ 2.33150	+ 3.58114	+ 5.19039
0.65	+ 1.42082	+ 2.49248	+ 3.92977	+ 5.81389
0.70	+ 1.46286	+ 2.66337	+ 4.30645	+ 6.49811
0.75	+ 1.50659	+ 2.84477	+ 4.71321	+ 7.24823
0.80	+ 1.55210	+ 3.03727	+ 5.15221	+ 8.06988
0.85	+ 1.59944	+ 3.24154	+ 5.62578	+ 8.96908
0.90	+ 1.64872	+ 3.45826	+ 6.13639	+ 9.95237
0.95	+ 1.70000	+ 3.68814	+ 6.68668	+ 11.0267
1.0	+ 1.75339	+ 3.93197	+ 7.27948	+ 12.1998
1.1	+ 1.86683	+ 4.46473	+ 8.60483	+ 14.8750
1.2	+ 1.98984	+ 5.06357	+ 10.1390	+ 18.0510
1.3	+ 2.12328	+ 5.73635	+ 11.9122	+ 21.8121
1.4	+ 2.26810	+ 6.49185	+ 13.9588	+ 26.2560
1.5	+ 2.42533	+ 7.33986	+ 16.3179	+ 31.4955
1.6	+ 2.59613	+ 8.29130	+ 19.0338	+ 37.6608
1.7	+ 2.78172	+ 9.35836	+ 22.1567	+ 44.9023
1.8	+ 2.98346	+ 10.5546	+ 25.7439	+ 53.3930
1.9	+ 3.20285	+ 11.8952	+ 29.8600	+ 63.3324
2.0	+ 3.44152	+ 13.3971	+ 34.5784	+ 74.9499
2.2	+ 3.98401	+ 16.9621	+ 46.1658	+ 104.314
2.4	+ 4.62733	+ 21.4277	+ 61.3121	+ 144.102
2.6	+ 5.39122	+ 27.0150	+ 81.0490	+ 197.760
2.8	+ 6.29933	+ 33.9986	+ 106.696	+ 269.814
3.0	+ 7.38010	+ 42.7190	+ 139.937	+ 366.191
3.5	+ 11.0791	+ 75.1437	+ 271.834	+ 770.415
4.0	+ 16.8440	+ 131.233	+ 519.318	+ 1583.08
4.5	+ 25.8738	+ 227.865	+ 978.790	+ 3191.17
5.0	+ 40.0784	+ 393.770	+ 1824.23	+ 6330.98
5.5	+ 62.5213	+ 677.927	+ 3368.79	+ 12394.7
6.0	+ 98.0333	+ 1162.67	+ 6168.21	+ 23975.2
6.5	+ 154.467	+ 1988.73	+ 11218.0	+ 45922.4
7.0	+ 244.333	+ 3393.22	+ 20277.9	+ 87186.8
7.5	+ 387.747	+ 5776.96	+ 36458.2	+ 164241.5
8.0	+ 617.064	+ 9816.37	+ 65236.8	+ 307246.6

M ($\alpha . 1 . x$)

x	$\alpha = -\frac{1}{2}$	$\alpha = -\frac{3}{2}$	$\alpha = -\frac{5}{2}$	$\alpha = -\frac{7}{2}$
0.00	+ 1.00000	+ 1.00000	+ 1.00000	+ 1.00000
0.02	+ 0.98997	+ 0.97008	+ 0.95037	+ 0.93087
0.04	+ 0.97990	+ 0.94030	+ 0.90150	+ 0.86348
0.06	+ 0.96977	+ 0.91068	+ 0.85336	+ 0.79780
0.08	+ 0.95959	+ 0.88121	+ 0.80597	+ 0.73381
0.10	+ 0.94936	+ 0.85189	+ 0.75932	+ 0.67151
0.15	+ 0.92356	+ 0.77925	+ 0.64592	+ 0.52299
0.20	+ 0.89741	+ 0.70758	+ 0.53708	+ 0.38460
0.25	+ 0.87092	+ 0.63689	+ 0.43277	+ 0.25607
0.30	+ 0.84408	+ 0.56716	+ 0.33296	+ 0.13712
0.35	+ 0.81687	+ 0.49843	+ 0.23759	+ 0.02751
0.40	+ 0.78929	+ 0.43069	+ 0.14662	- 0.07304
0.45	+ 0.76132	+ 0.36396	+ 0.06003	- 0.16478
0.50	+ 0.73296	+ 0.29824	- 0.02224	- 0.24798
0.55	+ 0.70420	+ 0.23355	- 0.10023	- 0.32288
0.60	+ 0.67502	+ 0.16988	- 0.17397	- 0.38976
0.65	+ 0.64541	+ 0.10727	- 0.24351	- 0.44884
0.70	+ 0.61537	+ 0.04570	- 0.30890	- 0.50040
0.75	+ 0.58487	- 0.01480	- 0.37017	- 0.54468
0.80	+ 0.55392	- 0.07423	- 0.42737	- 0.51892
0.85	+ 0.52248	- 0.13258	- 0.48054	- 0.61238
0.90	+ 0.49056	- 0.18983	- 0.52972	- 0.63629
0.95	+ 0.45814	- 0.24597	- 0.57497	- 0.65390
1.0	+ 0.42520	- 0.30100	- 0.61632	- 0.66545
1.1	+ 0.35770	- 0.40765	- 0.68750	- 0.67132
1.2	+ 0.28796	- 0.50970	- 0.74364	- 0.65578
1.3	+ 0.21583	- 0.60704	- 0.78510	- 0.62068
1.4	+ 0.14118	- 0.69956	- 0.81225	- 0.56785
1.5	+ 0.06386	- 0.78716	- 0.82547	- 0.49907
1.6	- 0.01630	- 0.86972	- 0.82515	- 0.41610
1.7	- 0.09948	- 0.94713	- 0.81168	- 0.32068
1.8	- 0.18585	- 1.01927	- 0.78545	- 0.21449
1.9	- 0.27562	- 1.08599	- 0.74686	- 0.09919
2.0	- 0.36900	- 1.14717	- 0.69634	+ 0.02359
2.2	- 0.56754	- 1.25233	- 0.56116	+ 0.28527
2.4	- 0.78351	- 1.33351	- 0.38334	+ 0.55821
2.6	- 1.01929	- 1.38936	- 0.16647	+ 0.83069
2.8	- 1.27761	- 1.41839	+ 0.08574	+ 1.09152
3.0	- 1.56163	- 1.41895	+ 0.36940	+ 1.33016
3.5	- 2.40973	- 1.28329	+ 1.18918	+ 1.76605
4.0	- 3.51873	- 0.92302	+ 2.11124	+ 1.86572
4.5	- 4.99928	- 0.29246	+ 3.05806	+ 1.51950
5.0	- 7.01438	+ 0.66928	+ 3.94092	+ 0.64792
5.5	- 9.80795	+ 2.04476	+ 4.65791	- 0.79513
6.0	- 13.7333	+ 3.94440	+ 5.08447	- 2.81743
6.5	- 19.3375	+ 6.52363	+ 5.07890	- 5.38529
7.0	- 27.4321	+ 9.99599	+ 4.46405	- 8.41543
7.5	- 39.2484	+ 14.6616	+ 3.02273	- 11.7681
8.0	- 56.6583	+ 20.9451	+ 0.48284	- 15.2367

M ($\alpha . 2 . x$)

x	$\alpha=1$	$\alpha=2$	$\alpha=3$	$\alpha=4$
0.00	+ 1.00000	+ 1.00000	+ 1.00000	+ 1.00000
0.02	+ 1.01007	+ 1.02020	+ 1.03040	+ 1.04067
0.04	+ 1.02027	+ 1.04081	+ 1.06163	+ 1.08272
0.06	+ 1.03061	+ 1.06184	+ 1.09369	+ 1.12618
0.08	+ 1.04109	+ 1.08329	+ 1.12662	+ 1.17111
0.10	+ 1.05171	+ 1.10517	+ 1.16043	+ 1.21753
0.15	+ 1.07889	+ 1.16183	+ 1.24897	+ 1.34047
0.20	+ 1.10701	+ 1.22140	+ 1.34354	+ 1.47383
0.25	+ 1.13610	+ 1.28403	+ 1.44453	+ 1.61841
0.30	+ 1.16620	+ 1.34986	+ 1.55234	+ 1.77506
0.35	+ 1.19734	+ 1.41907	+ 1.66740	+ 1.94471
0.40	+ 1.22956	+ 1.49182	+ 1.79019	+ 2.12834
0.45	+ 1.26292	+ 1.56831	+ 1.92118	+ 2.32698
0.50	+ 1.29744	+ 1.64872	+ 2.06090	+ 2.54178
0.55	+ 1.33319	+ 1.73325	+ 2.20990	+ 2.77393
0.60	+ 1.37020	+ 1.82212	+ 2.36875	+ 3.02472
0.65	+ 1.40852	+ 1.91554	+ 2.53809	+ 3.29553
0.70	+ 1.44822	+ 2.01375	+ 2.71857	+ 3.58784
0.75	+ 1.48933	+ 2.11700	+ 2.91088	+ 3.90322
0.80	+ 1.53193	+ 2.22554	+ 3.11576	+ 4.24336
0.85	+ 1.57606	+ 2.33965	+ 3.33400	+ 4.61008
0.90	+ 1.62178	+ 2.45960	+ 3.56642	+ 5.00529
0.95	+ 1.66917	+ 2.58571	+ 3.81392	+ 5.43107
1.0	+ 1.71828	+ 2.71828	+ 4.07742	+ 5.88961
1.1	+ 1.82197	+ 3.00417	+ 4.65646	+ 6.91459
1.2	+ 1.93343	+ 3.32012	+ 5.31219	+ 8.10109
1.3	+ 2.05331	+ 3.66930	+ 6.05434	+ 9.47290
1.4	+ 2.18229	+ 4.05520	+ 6.89384	+ 11.0572
1.5	+ 2.32113	+ 4.48169	+ 7.84296	+ 12.8849
1.6	+ 2.47065	+ 4.95303	+ 8.91546	+ 14.9912
1.7	+ 2.63173	+ 5.47395	+ 10.1268	+ 17.4163
1.8	+ 2.80536	+ 6.04965	+ 11.4943	+ 20.2058
1.9	+ 2.99258	+ 6.68589	+ 13.0375	+ 23.4118
2.0	+ 3.19453	+ 7.38906	+ 14.7781	+ 27.0932
2.2	+ 3.64773	+ 9.02501	+ 18.9525	+ 36.1602
2.4	+ 4.17632	+ 11.0232	+ 24.2510	+ 48.0610
2.6	+ 4.79375	+ 13.4637	+ 30.9666	+ 63.6386
2.8	+ 5.51595	+ 16.4446	+ 39.4672	+ 83.9773
3.0	+ 6.36185	+ 20.0855	+ 50.2138	+ 110.470
3.5	+ 9.17584	+ 33.1155	+ 91.0675	+ 216.630
4.0	+ 13.3995	+ 54.5982	+ 163.794	+ 418.586
4.5	+ 19.7816	+ 90.0171	+ 292.556	+ 798.902
5.0	+ 29.4826	+ 148.413	+ 519.446	+ 1508.87
5.5	+ 44.3076	+ 244.692	+ 917.595	+ 2824.15
6.0	+ 67.0715	+ 403.429	+ 1613.72	+ 5244.57
6.5	+ 102.176	+ 665.142	+ 2826.85	+ 9672.27
7.0	+ 156.519	+ 1096.63	+ 4934.85	+ 17728.9
7.5	+ 240.939	+ 1808.04	+ 8588.20	+ 32318.8
8.0	+ 372.495	+ 2980.96	+ 14904.8	+ 58625.5

M ($\alpha . 2 . x$)

x	$\alpha = -1$	$\alpha = -2$	$\alpha = -3$	$\alpha = -4$
0.00	+ 1.00000	+ 1.00000	+ 1.00000	+ 1.00000
0.02	+ 0.99000	+ 0.98007	+ 0.97020	+ 0.96040
0.04	+ 0.98000	+ 0.96027	+ 0.94080	+ 0.92159
0.06	+ 0.97000	+ 0.94060	+ 0.91179	+ 0.88356
0.08	+ 0.96000	+ 0.92107	+ 0.88318	+ 0.84632
0.10	+ 0.95000	+ 0.90167	+ 0.85496	+ 0.80983
0.15	+ 0.92500	+ 0.85375	+ 0.78611	+ 0.72194
0.20	+ 0.90000	+ 0.80667	+ 0.71967	+ 0.63868
0.25	+ 0.87500	+ 0.76042	+ 0.65560	+ 0.55993
0.30	+ 0.85000	+ 0.71500	+ 0.59388	+ 0.48557
0.35	+ 0.82500	+ 0.67042	+ 0.53446	+ 0.41548
0.40	+ 0.80000	+ 0.62667	+ 0.47733	+ 0.34955
0.45	+ 0.77500	+ 0.58375	+ 0.42245	+ 0.28765
0.50	+ 0.75000	+ 0.54167	+ 0.36979	+ 0.22969
0.55	+ 0.72500	+ 0.50042	+ 0.31932	+ 0.17553
0.60	+ 0.70000	+ 0.46000	+ 0.27100	+ 0.12508
0.65	+ 0.67500	+ 0.42042	+ 0.22481	+ 0.07822
0.70	+ 0.65000	+ 0.38167	+ 0.18071	+ 0.03483
0.75	+ 0.62500	+ 0.34375	+ 0.13867	- 0.00518
0.80	+ 0.60000	+ 0.30667	+ 0.09867	- 0.04192
0.85	+ 0.57500	+ 0.27042	+ 0.06066	- 0.07550
0.90	+ 0.55000	+ 0.23500	+ 0.02463	- 0.10603
0.95	+ 0.52500	+ 0.20042	- 0.00947	- 0.13361
1.0	+ 0.50000	+ 0.16667	- 0.04167	- 0.15833
1.1	+ 0.45000	+ 0.10167	- 0.10046	- 0.19963
1.2	+ 0.40000	+ 0.04000	- 0.15200	- 0.23072
1.3	+ 0.35000	- 0.01833	- 0.19654	- 0.25237
1.4	+ 0.30000	- 0.07333	- 0.23433	- 0.26532
1.5	+ 0.25000	- 0.12500	- 0.26563	- 0.27031
1.6	+ 0.20000	- 0.17333	- 0.29067	- 0.26805
1.7	+ 0.15000	- 0.21833	- 0.30971	- 0.25923
1.8	+ 0.10000	- 0.26000	- 0.32300	- 0.24452
1.9	+ 0.05000	- 0.29833	- 0.33079	- 0.22457
2.0	+ 0.00000	- 0.33333	- 0.33333	- 0.20000
2.2	- 0.10000	- 0.39333	- 0.32367	- 0.13945
2.4	- 0.20000	- 0.44000	- 0.29600	- 0.06752
2.6	- 0.30000	- 0.47333	- 0.25233	+ 0.01148
2.8	- 0.40000	- 0.49333	- 0.19467	+ 0.09355
3.0	- 0.50000	- 0.50000	- 0.12500	+ 0.17500
3.5	- 0.75000	- 0.45833	+ 0.08854	+ 0.35469
4.0	- 1.00000	- 0.33333	+ 0.33333	+ 0.46667
4.5	- 1.25000	- 0.12500	+ 0.57813	+ 0.47969
5.0	- 1.50000	+ 0.16667	+ 0.79167	+ 0.37500
5.5	- 1.75000	+ 0.54167	+ 0.94271	+ 0.14635
6.0	- 2.00000	+ 1.00000	+ 1.00000	- 0.20000
6.5	- 2.25000	+ 1.54167	+ 0.93229	- 0.64531
7.0	- 2.50000	+ 2.16667	+ 0.70833	- 1.15833
7.5	- 2.75000	+ 2.87500	+ 0.29688	- 1.69531
8.0	- 3.00000	+ 3.66667	- 0.33333	- 2.20000

M($\alpha . 2 . x$)

x	$\alpha = \frac{1}{2}$	$\alpha = \frac{3}{2}$	$\alpha = \frac{5}{2}$	$\alpha = \frac{7}{2}$
0.00	+ 1.00000	+ 1.00000	+ 1.00000	+ 1.00000
0.02	+ 1.00503	+ 1.01513	+ 1.02529	+ 1.03553
0.04	+ 1.01010	+ 1.03051	+ 1.05118	+ 1.07214
0.06	+ 1.01523	+ 1.04614	+ 1.07769	+ 1.10986
0.08	+ 1.02041	+ 1.06205	+ 1.10481	+ 1.14872
0.10	+ 1.02564	+ 1.07822	+ 1.13257	+ 1.18875
0.15	+ 1.03895	+ 1.11985	+ 1.20487	+ 1.29416
0.20	+ 1.05261	+ 1.16326	+ 1.28148	+ 1.40764
0.25	+ 1.06662	+ 1.20854	+ 1.36266	+ 1.52974
0.30	+ 1.08100	+ 1.25576	+ 1.44866	+ 1.66108
0.35	+ 1.09575	+ 1.30502	+ 1.53977	+ 1.80228
0.40	+ 1.11090	+ 1.35640	+ 1.63627	+ 1.95405
0.45	+ 1.12644	+ 1.41000	+ 1.73848	+ 2.11711
0.50	+ 1.14241	+ 1.46593	+ 1.84673	+ 2.29224
0.55	+ 1.15880	+ 1.52428	+ 1.96135	+ 2.48027
0.60	+ 1.17564	+ 1.58517	+ 2.08272	+ 2.68209
0.65	+ 1.19293	+ 1.64871	+ 2.21122	+ 2.89864
0.70	+ 1.21070	+ 1.71502	+ 2.34726	+ 3.13093
0.75	+ 1.22896	+ 1.78423	+ 2.49125	+ 3.38004
0.80	+ 1.24772	+ 1.85647	+ 2.64367	+ 3.64709
0.85	+ 1.26701	+ 1.93188	+ 2.80499	+ 3.93330
0.90	+ 1.28684	+ 2.01060	+ 2.97570	+ 4.23998
0.95	+ 1.30723	+ 2.09278	+ 3.15636	+ 4.56849
1.0	+ 1.32819	+ 2.17858	+ 3.34751	+ 4.92030
1.1	+ 1.37193	+ 2.36173	+ 3.76373	+ 5.70017
1.2	+ 1.41823	+ 2.56144	+ 4.22953	+ 6.59331
1.3	+ 1.46726	+ 2.77929	+ 4.75066	+ 7.61528
1.4	+ 1.51922	+ 3.01697	+ 5.33356	+ 8.78367
1.5	+ 1.57432	+ 3.27635	+ 5.98536	+ 10.1184
1.6	+ 1.63277	+ 3.55949	+ 6.71403	+ 11.6419
1.7	+ 1.69482	+ 3.86861	+ 7.52844	+ 13.3797
1.8	+ 1.76073	+ 4.20620	+ 8.43848	+ 15.3606
1.9	+ 1.83078	+ 4.57493	+ 9.45513	+ 17.6171
2.0	+ 1.90526	+ 4.97779	+ 10.5907	+ 20.1858
2.2	+ 2.06888	+ 5.89913	+ 13.2744	+ 26.4310
2.4	+ 2.25452	+ 7.00015	+ 16.6185	+ 34.4959
2.6	+ 2.46558	+ 8.31685	+ 20.7823	+ 44.8890
2.8	+ 2.70605	+ 9.89261	+ 25.9633	+ 58.2563
3.0	+ 2.98058	+ 11.7796	+ 32.4059	+ 75.4181
3.5	+ 3.85394	+ 18.3042	+ 56.1972	+ 142.452
4.0	+ 5.09068	+ 28.5973	+ 97.0212	+ 265.940
4.5	+ 6.86068	+ 44.8869	+ 166.872	+ 491.639
5.0	+ 9.41857	+ 70.7383	+ 286.093	+ 901.349
5.5	+ 13.1508	+ 111.892	+ 489.248	+ 1641.07
6.0	+ 18.6278	+ 177.439	+ 834.257	+ 2967.84
6.5	+ 26.7392	+ 282.195	+ 1419.89	+ 5339.13
7.0	+ 38.8235	+ 449.842	+ 2412.10	+ 9558.42
7.5	+ 56.9328	+ 718.562	+ 4090.83	+ 17037.8
8.0	+ 84.2153	+ 1149.91	+ 6927.55	+ 30251.2

M ($\alpha . 2 . x$)

x	$\alpha = -\frac{1}{2}$	$\alpha = -\frac{3}{2}$	$\alpha = -\frac{5}{2}$	$\alpha = -\frac{7}{2}$
0-00	+ 1-00000	+ 1-00000	+ 1-00000	+ 1-00000
0-02	+ 0-99499	+ 0-98503	+ 0-97512	+ 0-96529
0-04	+ 0-98997	+ 0-97010	+ 0-95050	+ 0-93116
0-06	+ 0-98492	+ 0-95523	+ 0-92612	+ 0-89761
0-08	+ 0-97987	+ 0-94040	+ 0-90199	+ 0-86462
0-10	+ 0-97479	+ 0-92563	+ 0-87811	+ 0-83220
0-15	+ 0-96202	+ 0-88892	+ 0-81949	+ 0-75360
0-20	+ 0-94915	+ 0-85252	+ 0-76240	+ 0-67844
0-25	+ 0-93616	+ 0-81645	+ 0-70683	+ 0-60666
0-30	+ 0-92305	+ 0-78070	+ 0-65277	+ 0-53818
0-35	+ 0-90983	+ 0-74527	+ 0-60022	+ 0-47295
0-40	+ 0-89649	+ 0-71017	+ 0-54916	+ 0-41089
0-45	+ 0-88303	+ 0-67540	+ 0-49958	+ 0-35194
0-50	+ 0-86944	+ 0-64096	+ 0-45148	+ 0-29604
0-55	+ 0-85573	+ 0-60686	+ 0-40483	+ 0-24312
0-60	+ 0-84189	+ 0-57309	+ 0-35964	+ 0-19311
0-65	+ 0-82792	+ 0-53966	+ 0-31590	+ 0-14595
0-70	+ 0-81381	+ 0-50657	+ 0-27358	+ 0-10158
0-75	+ 0-79957	+ 0-47382	+ 0-23268	+ 0-05993
0-80	+ 0-78519	+ 0-44142	+ 0-19319	+ 0-02095
0-85	+ 0-77066	+ 0-40937	+ 0-15511	- 0-01545
0-90	+ 0-75599	+ 0-37766	+ 0-11841	- 0-04930
0-95	+ 0-74117	+ 0-34631	+ 0-08309	- 0-08069
1-0	+ 0-72619	+ 0-31532	+ 0-04914	- 0-10966
1-1	+ 0-69578	+ 0-25441	- 0-01471	- 0-16062
1-2	+ 0-66472	+ 0-19495	- 0-07322	- 0-20268
1-3	+ 0-63298	+ 0-13697	- 0-12648	- 0-23630
1-4	+ 0-60053	+ 0-08050	- 0-17458	- 0-26197
1-5	+ 0-56735	+ 0-02554	- 0-21760	- 0-28015
1-6	+ 0-53339	- 0-02786	- 0-25566	- 0-29131
1-7	+ 0-49862	- 0-07968	- 0-28882	- 0-29590
1-8	+ 0-46301	- 0-12990	- 0-31720	- 0-29437
1-9	+ 0-42651	- 0-17849	- 0-34088	- 0-28717
2-0	+ 0-38909	- 0-22542	- 0-35997	- 0-27473
2-2	+ 0-31127	- 0-31417	- 0-38474	- 0-23585
2-4	+ 0-22917	- 0-39590	- 0-39231	- 0-18109
2-6	+ 0-14233	- 0-47034	- 0-38352	- 0-11370
2-8	+ 0-05028	- 0-53719	- 0-35921	- 0-03682
3-0	- 0-04756	- 0-59612	- 0-32025	+ 0-04651
3-5	- 0-32184	- 0-70642	- 0-16482	+ 0-26426
4-0	- 0-64893	- 0-75856	+ 0-06138	+ 0-46234
4-5	- 1-04596	- 0-74456	+ 0-34190	+ 0-60359
5-0	- 1-53673	- 0-65433	+ 0-65860	+ 0-65623
5-5	- 2-15504	- 0-47512	+ 0-99146	+ 0-59444
6-0	- 2-94629	- 0-19001	+ 1-31698	+ 0-39822
6-5	- 3-97864	+ 0-22227	+ 1-60988	+ 0-05539
7-0	- 5-34686	+ 0-79028	+ 1-83993	- 0-43904
7-5	- 7-18801	+ 1-55186	+ 1-97211	- 1-08126
8-0	- 9-70042	+ 2-55778	+ 1-96494	- 1-85764

M ($\alpha . 3 . x$)

x	$\alpha=1$	$\alpha=2$	$\alpha=3$	$\alpha=4$
0.00	+ 1.00000	+ 1.00000	+ 1.00000	+ 1.00000
0.02	+ 1.00670	+ 1.01343	+ 1.02020	+ 1.02700
0.04	+ 1.01347	+ 1.02707	+ 1.04081	+ 1.05469
0.06	+ 1.02030	+ 1.04091	+ 1.06184	+ 1.08307
0.08	+ 1.02721	+ 1.05497	+ 1.08329	+ 1.11217
0.10	+ 1.03418	+ 1.06923	+ 1.10517	+ 1.14201
0.15	+ 1.05193	+ 1.10586	+ 1.16183	+ 1.21993
0.20	+ 1.07014	+ 1.14389	+ 1.22140	+ 1.30283
0.25	+ 1.08881	+ 1.18339	+ 1.28403	+ 1.39103
0.30	+ 1.10797	+ 1.22442	+ 1.34986	+ 1.48484
0.35	+ 1.12763	+ 1.26704	+ 1.41907	+ 1.58463
0.40	+ 1.14781	+ 1.31131	+ 1.49182	+ 1.69073
0.45	+ 1.16852	+ 1.35732	+ 1.56831	+ 1.80356
0.50	+ 1.18977	+ 1.40511	+ 1.64872	+ 1.92351
0.55	+ 1.21159	+ 1.45478	+ 1.73325	+ 2.05102
0.60	+ 1.23399	+ 1.50640	+ 1.82212	+ 2.18654
0.65	+ 1.25700	+ 1.56005	+ 1.91554	+ 2.33057
0.70	+ 1.28062	+ 1.61581	+ 2.01375	+ 2.48363
0.75	+ 1.30489	+ 1.67378	+ 2.11700	+ 2.64625
0.80	+ 1.32982	+ 1.73404	+ 2.22554	+ 2.81902
0.85	+ 1.35542	+ 1.79669	+ 2.33965	+ 3.00255
0.90	+ 1.38174	+ 1.86183	+ 2.45960	+ 3.19748
0.95	+ 1.40877	+ 1.92956	+ 2.58571	+ 3.40452
1.0	+ 1.43656	+ 2.00000	+ 2.71828	+ 3.62438
1.1	+ 1.49449	+ 2.14945	+ 3.00417	+ 4.10569
1.2	+ 1.55572	+ 2.31114	+ 3.32012	+ 4.64816
1.3	+ 1.62047	+ 2.48614	+ 3.66930	+ 5.25933
1.4	+ 1.68898	+ 2.67559	+ 4.05520	+ 5.94763
1.5	+ 1.76150	+ 2.88075	+ 4.48169	+ 6.72253
1.6	+ 1.83831	+ 3.10298	+ 4.95303	+ 7.59465
1.7	+ 1.91969	+ 3.34378	+ 5.47395	+ 8.57585
1.8	+ 2.00596	+ 3.60476	+ 6.04965	+ 9.67944
1.9	+ 2.09745	+ 3.88770	+ 6.68589	+ 10.9203
2.0	+ 2.19453	+ 4.19453	+ 7.38906	+ 12.3151
2.2	+ 2.40703	+ 4.88844	+ 9.02501	+ 15.6434
2.4	+ 2.64694	+ 5.70571	+ 11.0232	+ 19.8417
2.6	+ 2.91827	+ 6.66923	+ 13.4637	+ 25.1323
2.8	+ 3.22568	+ 7.80622	+ 16.4446	+ 31.7930
3.0	+ 3.57456	+ 9.14913	+ 20.0855	+ 40.1711
3.5	+ 4.67191	+ 13.6798	+ 33.1155	+ 71.7501
4.0	+ 6.19977	+ 20.5993	+ 54.5982	+ 127.396
4.5	+ 8.34737	+ 31.2158	+ 90.0171	+ 225.043
5.0	+ 11.3931	+ 47.5722	+ 148.413	+ 395.768
5.5	+ 15.7482	+ 72.8670	+ 244.692	+ 693.294
6.0	+ 22.0238	+ 112.119	+ 403.429	+ 1210.29
6.5	+ 31.1310	+ 173.220	+ 665.142	+ 2106.28
7.0	+ 44.4340	+ 268.604	+ 1096.63	+ 3655.44
7.5	+ 63.9837	+ 417.894	+ 1808.04	+ 6328.15
8.0	+ 92.8737	+ 652.116	+ 2980.96	+ 10930.2

M ($\alpha. 3. x$)

x	$\alpha = -1$	$\alpha = -2$	$\alpha = -3$	$\alpha = -4$
0.00	+ 1.00000	+ 1.00000	+ 1.00000	+ 1.00000
0.02	+ 0.99333	+ 0.98670	+ 0.98010	+ 0.97353
0.04	+ 0.98667	+ 0.97347	+ 0.96040	+ 0.94746
0.06	+ 0.98000	+ 0.96030	+ 0.94090	+ 0.92179
0.08	+ 0.97333	+ 0.94720	+ 0.92159	+ 0.89650
0.10	+ 0.96667	+ 0.93417	+ 0.90248	+ 0.87160
0.15	+ 0.95000	+ 0.90188	+ 0.85557	+ 0.81103
0.20	+ 0.93333	+ 0.87000	+ 0.80987	+ 0.75280
0.25	+ 0.91667	+ 0.83854	+ 0.76536	+ 0.69689
0.30	+ 0.90000	+ 0.80750	+ 0.72205	+ 0.64322
0.35	+ 0.88333	+ 0.77688	+ 0.67991	+ 0.59177
0.40	+ 0.86667	+ 0.74667	+ 0.63893	+ 0.54247
0.45	+ 0.85000	+ 0.71688	+ 0.59911	+ 0.49529
0.50	+ 0.83333	+ 0.68750	+ 0.56042	+ 0.45017
0.55	+ 0.81667	+ 0.65854	+ 0.52285	+ 0.40708
0.60	+ 0.80000	+ 0.63000	+ 0.48640	+ 0.36596
0.65	+ 0.78333	+ 0.60188	+ 0.45105	+ 0.32677
0.70	+ 0.76667	+ 0.57417	+ 0.41678	+ 0.28947
0.75	+ 0.75000	+ 0.54688	+ 0.38359	+ 0.25400
0.80	+ 0.73333	+ 0.52000	+ 0.35147	+ 0.22034
0.85	+ 0.71667	+ 0.49354	+ 0.32039	+ 0.18843
0.90	+ 0.70000	+ 0.46750	+ 0.29035	+ 0.15822
0.95	+ 0.68333	+ 0.44188	+ 0.26134	+ 0.12969
1.0	+ 0.66667	+ 0.41667	+ 0.23333	+ 0.10278
1.1	+ 0.63333	+ 0.36750	+ 0.18032	+ 0.05367
1.2	+ 0.60000	+ 0.32000	+ 0.13120	+ 0.01056
1.3	+ 0.56667	+ 0.27417	+ 0.08588	- 0.02687
1.4	+ 0.53333	+ 0.23000	+ 0.04427	- 0.05893
1.5	+ 0.50000	+ 0.18750	+ 0.00625	- 0.08594
1.6	+ 0.46667	+ 0.14667	- 0.02827	- 0.10820
1.7	+ 0.43333	+ 0.10750	- 0.05938	- 0.12600
1.8	+ 0.40000	+ 0.07000	- 0.08720	- 0.13964
1.9	+ 0.36667	+ 0.03417	- 0.11182	- 0.14940
2.0	+ 0.33333	+ 0.00000	- 0.13333	- 0.15556
2.2	+ 0.26667	- 0.06333	- 0.16747	- 0.15813
2.4	+ 0.20000	- 0.12000	- 0.19040	- 0.14944
2.6	+ 0.13333	- 0.17000	- 0.20293	- 0.13146
2.8	+ 0.06667	- 0.21333	- 0.20587	- 0.10606
3.0	+ 0.00000	- 0.25000	- 0.20000	- 0.07500
3.5	- 0.16667	- 0.31250	- 0.15208	+ 0.01684
4.0	- 0.33333	- 0.33333	- 0.06667	+ 0.11111
4.5	- 0.50000	- 0.31250	+ 0.04375	+ 0.18906
5.0	- 0.66667	- 0.25000	+ 0.16667	+ 0.23611
5.5	- 0.83333	- 0.14583	+ 0.28958	+ 0.24184
6.0	- 1.00000	+ 0.00000	+ 0.40000	+ 0.20000
6.5	- 1.16667	+ 0.18750	+ 0.48542	+ 0.10851
7.0	- 1.33333	+ 0.41667	+ 0.53333	- 0.03056
7.5	- 1.50000	+ 0.68750	+ 0.53125	- 0.21094
8.0	- 1.66667	+ 1.00000	+ 0.46667	- 0.42222

M($\alpha . 3 . x$)

x	$\alpha = \frac{1}{2}$	$\alpha = \frac{3}{2}$	$\alpha = \frac{5}{2}$	$\alpha = \frac{7}{2}$
0.00	+ 1.00000	+ 1.00000	+ 1.00000	+ 1.00000
0.02	+ 1.00335	+ 1.01006	+ 1.01681	+ 1.02360
0.04	+ 1.00672	+ 1.02025	+ 1.03392	+ 1.04773
0.06	+ 1.01011	+ 1.03057	+ 1.05134	+ 1.07242
0.08	+ 1.01354	+ 1.04102	+ 1.06906	+ 1.09766
0.10	+ 1.01698	+ 1.05160	+ 1.08709	+ 1.12348
0.15	+ 1.02572	+ 1.07864	+ 1.13359	+ 1.19061
0.20	+ 1.03463	+ 1.10655	+ 1.18217	+ 1.26162
0.25	+ 1.04370	+ 1.13536	+ 1.23293	+ 1.33671
0.30	+ 1.05296	+ 1.16510	+ 1.28598	+ 1.41612
0.35	+ 1.06240	+ 1.19581	+ 1.34142	+ 1.50010
0.40	+ 1.07202	+ 1.22752	+ 1.39936	+ 1.58889
0.45	+ 1.08184	+ 1.26026	+ 1.45992	+ 1.68277
0.50	+ 1.09185	+ 1.29408	+ 1.52321	+ 1.78205
0.55	+ 1.10206	+ 1.32902	+ 1.58937	+ 1.88696
0.60	+ 1.11248	+ 1.36510	+ 1.65852	+ 1.99788
0.65	+ 1.12311	+ 1.40238	+ 1.73081	+ 2.11514
0.70	+ 1.13397	+ 1.44091	+ 1.80639	+ 2.23908
0.75	+ 1.14504	+ 1.48072	+ 1.88540	+ 2.37008
0.80	+ 1.15635	+ 1.52186	+ 1.96801	+ 2.50854
0.85	+ 1.16789	+ 1.56439	+ 2.05437	+ 2.65486
0.90	+ 1.17967	+ 1.60835	+ 2.14468	+ 2.80950
0.95	+ 1.19171	+ 1.65379	+ 2.23911	+ 2.97291
1.0	+ 1.20399	+ 1.70078	+ 2.33785	+ 3.14558
1.1	+ 1.22937	+ 1.79962	+ 2.54909	+ 3.52080
1.2	+ 1.25586	+ 1.90535	+ 2.78014	+ 3.93695
1.3	+ 1.28352	+ 2.01850	+ 3.03288	+ 4.40711
1.4	+ 1.31242	+ 2.13964	+ 3.30941	+ 4.92873
1.5	+ 1.34263	+ 2.26938	+ 3.61201	+ 5.51069
1.6	+ 1.37423	+ 2.40840	+ 3.94318	+ 6.15986
1.7	+ 1.40729	+ 2.55740	+ 4.30568	+ 6.88389
1.8	+ 1.44191	+ 2.71719	+ 4.70253	+ 7.69129
1.9	+ 1.47817	+ 2.88859	+ 5.13705	+ 8.59151
2.0	+ 1.51618	+ 3.07252	+ 5.61287	+ 9.59510
2.2	+ 1.59783	+ 3.48204	+ 6.70482	+ 11.9605
2.4	+ 1.68779	+ 3.95469	+ 8.01530	+ 14.8979
2.6	+ 1.78711	+ 4.50098	+ 9.58881	+ 18.5436
2.8	+ 1.89698	+ 5.13326	+ 11.4791	+ 23.0664
3.0	+ 2.01876	+ 5.86603	+ 13.7508	+ 28.6749
3.5	+ 2.38616	+ 8.25728	+ 21.6531	+ 49.2884
4.0	+ 2.86980	+ 11.7533	+ 34.2119	+ 84.4593
4.5	+ 3.51406	+ 16.9005	+ 54.2157	+ 144.341
5.0	+ 4.38212	+ 24.5279	+ 86.1418	+ 246.103
5.5	+ 5.56575	+ 35.9059	+ 137.221	+ 418.843
6.0	+ 7.19135	+ 52.9370	+ 218.940	+ 711.194
6.5	+ 9.45163	+ 78.6018	+ 350.059	+ 1205.92
7.0	+ 12.6201	+ 117.434	+ 560.644	+ 2041.81
7.5	+ 17.0989	+ 176.434	+ 899.271	+ 3452.52
8.0	+ 23.4789	+ 266.424	+ 1444.41	+ 5830.92

M ($\alpha . 3 . x$)

x	$\alpha = -\frac{1}{2}$	$\alpha = -\frac{3}{2}$	$\alpha = -\frac{5}{2}$	$\alpha = -\frac{7}{2}$
0.00	+ 1.00000	+ 1.00000	+ 1.00000	+ 1.00000
0.02	+ 0.99666	+ 0.99001	+ 0.98340	+ 0.97681
0.04	+ 0.99332	+ 0.98005	+ 0.96692	+ 0.95391
0.06	+ 0.98996	+ 0.97011	+ 0.95056	+ 0.93130
0.08	+ 0.98660	+ 0.96020	+ 0.93433	+ 0.90898
0.10	+ 0.98323	+ 0.95031	+ 0.91822	+ 0.88694
0.15	+ 0.97476	+ 0.92571	+ 0.87850	+ 0.83308
0.20	+ 0.96624	+ 0.90126	+ 0.83954	+ 0.78096
0.25	+ 0.95767	+ 0.87697	+ 0.80135	+ 0.73055
0.30	+ 0.94903	+ 0.85284	+ 0.76392	+ 0.68183
0.35	+ 0.94034	+ 0.82887	+ 0.72725	+ 0.63478
0.40	+ 0.93160	+ 0.80507	+ 0.69133	+ 0.58935
0.45	+ 0.92279	+ 0.78143	+ 0.65616	+ 0.54554
0.50	+ 0.91393	+ 0.75795	+ 0.62174	+ 0.50330
0.55	+ 0.90500	+ 0.73463	+ 0.58806	+ 0.46262
0.60	+ 0.89601	+ 0.71148	+ 0.55511	+ 0.42347
0.65	+ 0.88696	+ 0.68850	+ 0.52290	+ 0.38583
0.70	+ 0.87784	+ 0.66569	+ 0.49142	+ 0.34966
0.75	+ 0.86866	+ 0.64304	+ 0.46066	+ 0.31494
0.80	+ 0.85942	+ 0.62056	+ 0.43062	+ 0.28165
0.85	+ 0.85011	+ 0.59825	+ 0.41030	+ 0.24976
0.90	+ 0.84072	+ 0.57612	+ 0.37269	+ 0.21924
0.95	+ 0.83127	+ 0.55415	+ 0.34479	+ 0.19007
1.0	+ 0.82175	+ 0.53236	+ 0.31759	+ 0.16223
1.1	+ 0.80250	+ 0.48930	+ 0.26530	+ 0.11042
1.2	+ 0.78294	+ 0.44695	+ 0.21576	+ 0.06360
1.3	+ 0.76308	+ 0.40531	+ 0.16896	+ 0.02159
1.4	+ 0.74291	+ 0.36439	+ 0.12485	- 0.01581
1.5	+ 0.72240	+ 0.32420	+ 0.08340	- 0.04880
1.6	+ 0.70156	+ 0.28475	+ 0.04457	- 0.07757
1.7	+ 0.68036	+ 0.24605	+ 0.00833	- 0.10230
1.8	+ 0.65879	+ 0.20811	- 0.02536	- 0.12318
1.9	+ 0.63684	+ 0.17094	- 0.05654	- 0.14040
2.0	+ 0.61450	+ 0.13455	- 0.08524	- 0.15414
2.2	+ 0.56858	+ 0.06415	- 0.13535	- 0.17190
2.4	+ 0.52089	- 0.00299	- 0.17602	- 0.17786
2.6	+ 0.47129	- 0.06679	- 0.20756	- 0.17343
2.8	+ 0.41962	- 0.12713	- 0.23027	- 0.15993
3.0	+ 0.3657	- 0.18391	- 0.24451	- 0.13868
3.5	+ 0.21976	- 0.30949	- 0.24519	- 0.05993
4.0	+ 0.05482	- 0.40997	- 0.20048	+ 0.04054
4.5	- 0.13396	- 0.48287	- 0.11631	+ 0.14547
5.0	- 0.35296	- 0.52517	+ 0.00095	+ 0.23923
5.5	- 0.61088	- 0.53330	+ 0.14437	+ 0.30803
6.0	- 0.91876	- 0.50233	+ 0.30625	+ 0.33970
6.5	- 1.29259	- 0.42696	+ 0.47830	+ 0.32452
7.0	- 1.75347	- 0.29990	+ 0.65113	+ 0.25471
7.5	- 2.33063	- 0.11207	+ 0.81423	+ 0.12496
8.0	- 3.06455	+ 0.14821	+ 0.95565	- 0.06737

M ($\alpha . 4 . x$)

x	$\alpha=1$	$\alpha=2$	$\alpha=3$	$\alpha=4$
0.00	+ 1.00000	+ 1.00000	+ 1.00000	+ 1.00000
0.02	+ 1.00502	+ 1.01006	+ 1.01512	+ 1.02020
0.04	+ 1.01008	+ 1.02024	+ 1.03049	+ 1.04081
0.06	+ 1.01518	+ 1.03055	+ 1.04610	+ 1.06184
0.08	+ 1.02032	+ 1.04098	+ 1.06196	+ 1.08329
0.10	+ 1.02551	+ 1.05153	+ 1.07809	+ 1.10517
0.15	+ 1.03865	+ 1.07849	+ 1.11954	+ 1.16183
0.20	+ 1.05207	+ 1.10628	+ 1.16270	+ 1.22140
0.25	+ 1.06576	+ 1.13492	+ 1.20763	+ 1.28403
0.30	+ 1.07974	+ 1.16445	+ 1.25440	+ 1.34986
0.35	+ 1.09400	+ 1.19490	+ 1.30311	+ 1.41907
0.40	+ 1.10857	+ 1.22630	+ 1.35382	+ 1.49182
0.45	+ 1.12344	+ 1.25867	+ 1.40664	+ 1.56831
0.50	+ 1.13862	+ 1.29207	+ 1.46164	+ 1.64872
0.55	+ 1.15413	+ 1.32651	+ 1.51892	+ 1.73325
0.60	+ 1.16997	+ 1.36205	+ 1.57858	+ 1.82212
0.65	+ 1.18614	+ 1.39870	+ 1.64072	+ 1.91554
0.70	+ 1.20267	+ 1.43653	+ 1.70546	+ 2.01375
0.75	+ 1.21956	+ 1.47556	+ 1.77289	+ 2.11700
0.80	+ 1.23681	+ 1.51583	+ 1.84314	+ 2.22554
0.85	+ 1.25444	+ 1.55740	+ 1.91633	+ 2.33965
0.90	+ 1.27245	+ 1.60030	+ 1.99259	+ 2.45960
0.95	+ 1.29087	+ 1.64459	+ 2.07205	+ 2.58571
1.0	+ 1.30969	+ 1.69031	+ 2.15485	+ 2.71828
1.1	+ 1.34861	+ 1.78625	+ 2.33105	+ 3.00417
1.2	+ 1.38929	+ 1.88856	+ 2.52243	+ 3.32012
1.3	+ 1.43185	+ 1.99770	+ 2.73036	+ 3.66930
1.4	+ 1.47638	+ 2.11417	+ 2.95630	+ 4.05520
1.5	+ 1.52300	+ 2.23850	+ 3.20188	+ 4.48169
1.6	+ 1.57184	+ 2.37127	+ 3.46884	+ 4.95303
1.7	+ 1.62298	+ 2.51311	+ 3.75912	+ 5.47395
1.8	+ 1.67659	+ 2.66468	+ 4.07481	+ 6.04965
1.9	+ 1.73281	+ 2.82672	+ 4.41820	+ 6.68589
2.0	+ 1.79179	+ 3.00000	+ 4.79179	+ 7.38906
2.2	+ 1.91868	+ 3.38374	+ 5.64079	+ 9.02501
2.4	+ 2.05867	+ 3.82347	+ 6.64683	+ 11.0232
2.6	+ 2.21338	+ 4.32803	+ 7.83982	+ 13.4637
2.8	+ 2.38465	+ 4.90772	+ 9.25546	+ 16.4446
3.0	+ 2.57456	+ 5.57456	+ 10.9364	+ 20.0855
3.5	+ 3.14735	+ 7.72103	+ 16.6592	+ 33.1155
4.0	+ 3.89983	+ 10.7997	+ 25.4991	+ 54.5982
4.5	+ 4.89825	+ 15.2456	+ 39.2009	+ 90.0171
5.0	+ 6.23583	+ 21.7075	+ 60.5046	+ 148.413
5.5	+ 8.04449	+ 31.1557	+ 93.7227	+ 244.692
6.0	+ 10.5119	+ 45.0476	+ 145.655	+ 403.429
6.5	+ 13.9066	+ 65.5797	+ 227.041	+ 665.142
7.0	+ 18.6146	+ 96.0729	+ 354.870	+ 1096.63
7.5	+ 25.1935	+ 141.564	+ 556.059	+ 1808.04
8.0	+ 34.4526	+ 209.716	+ 873.316	+ 2980.96

M ($\alpha . 4 . x$)

x	$\alpha = -1$	$\alpha = -2$	$\alpha = -3$	$\alpha = -4$
0.00	+ 1.00000	+ 1.00000	+ 1.00000	+ 1.00000
0.02	+ 0.99500	+ 0.99002	+ 0.98506	+ 0.98012
0.04	+ 0.99000	+ 0.98008	+ 0.97024	+ 0.96048
0.06	+ 0.98500	+ 0.97018	+ 0.95554	+ 0.94107
0.08	+ 0.98000	+ 0.96032	+ 0.94096	+ 0.92190
0.10	+ 0.97500	+ 0.95050	+ 0.92649	+ 0.90297
0.15	+ 0.96250	+ 0.92613	+ 0.89085	+ 0.85664
0.20	+ 0.95000	+ 0.90200	+ 0.85593	+ 0.81174
0.25	+ 0.93750	+ 0.87813	+ 0.82174	+ 0.76823
0.30	+ 0.92500	+ 0.85450	+ 0.78828	+ 0.72611
0.35	+ 0.91250	+ 0.83113	+ 0.75552	+ 0.68534
0.40	+ 0.90000	+ 0.80800	+ 0.72347	+ 0.64590
0.45	+ 0.88750	+ 0.78513	+ 0.69212	+ 0.60776
0.50	+ 0.87500	+ 0.76250	+ 0.66146	+ 0.57091
0.55	+ 0.86250	+ 0.74013	+ 0.63149	+ 0.53531
0.60	+ 0.85000	+ 0.71800	+ 0.60220	+ 0.50095
0.65	+ 0.83750	+ 0.69613	+ 0.57359	+ 0.46781
0.70	+ 0.82500	+ 0.67450	+ 0.54564	+ 0.43585
0.75	+ 0.81250	+ 0.65313	+ 0.51836	+ 0.40506
0.80	+ 0.80000	+ 0.63200	+ 0.49173	+ 0.37542
0.85	+ 0.78750	+ 0.61113	+ 0.46576	+ 0.34690
0.90	+ 0.77500	+ 0.59050	+ 0.44043	+ 0.31948
0.95	+ 0.76250	+ 0.57013	+ 0.41573	+ 0.29314
1.0	+ 0.75000	+ 0.55000	+ 0.39167	+ 0.26786
1.1	+ 0.72500	+ 0.51050	+ 0.34541	+ 0.22080
1.2	+ 0.70000	+ 0.47200	+ 0.30160	+ 0.17687
1.3	+ 0.67500	+ 0.43450	+ 0.26019	+ 0.13717
1.4	+ 0.65000	+ 0.39800	+ 0.22113	+ 0.10111
1.5	+ 0.62500	+ 0.36250	+ 0.18438	+ 0.06853
1.6	+ 0.60000	+ 0.32800	+ 0.14987	+ 0.03927
1.7	+ 0.57500	+ 0.29450	+ 0.11756	+ 0.01318
1.8	+ 0.55000	+ 0.26200	+ 0.08740	- 0.00990
1.9	+ 0.52500	+ 0.23050	+ 0.05934	- 0.03012
2.0	+ 0.50000	+ 0.20000	+ 0.03333	- 0.04762
2.2	+ 0.45000	+ 0.14200	- 0.01273	- 0.07505
2.4	+ 0.40000	+ 0.08800	- 0.05120	- 0.09330
2.6	+ 0.35000	+ 0.03800	- 0.08247	- 0.10346
2.8	+ 0.30000	- 0.00800	- 0.10693	- 0.10656
3.0	+ 0.25000	- 0.05000	- 0.12500	- 0.10357
3.5	+ 0.12500	- 0.13750	- 0.14479	- 0.07552
4.0	+ 0.00000	- 0.20000	- 0.13333	- 0.02857
4.5	- 0.12500	- 0.23750	- 0.09688	+ 0.02567
5.0	- 0.25000	- 0.25000	- 0.04167	+ 0.07738
5.5	- 0.37500	- 0.23750	+ 0.02604	+ 0.11853
6.0	- 0.50000	- 0.20000	+ 0.10000	+ 0.14286
6.5	- 0.62500	- 0.13750	+ 0.17396	+ 0.14591
7.0	- 0.75000	- 0.05000	+ 0.24167	+ 0.12500
7.5	- 0.87500	+ 0.06250	+ 0.29688	+ 0.07924
8.0	- 1.00000	+ 0.20000	+ 0.33333	+ 0.00952

M ($\alpha . 4 . x$)

x	$\alpha = \frac{1}{2}$	$\alpha = \frac{3}{2}$	$\alpha = \frac{5}{2}$	$\alpha = \frac{7}{2}$
0.00	+ 1.00000	+ 1.00000	+ 1.00000	+ 1.00000
0.02	+ 1.00251	+ 1.00754	+ 1.01259	+ 1.01766
0.04	+ 1.00503	+ 1.01515	+ 1.02535	+ 1.03564
0.06	+ 1.00757	+ 1.02284	+ 1.03830	+ 1.05394
0.08	+ 1.01012	+ 1.03061	+ 1.05143	+ 1.07258
0.10	+ 1.01269	+ 1.03846	+ 1.06474	+ 1.09156
0.15	+ 1.01918	+ 1.05842	+ 1.09886	+ 1.14053
0.20	+ 1.02577	+ 1.07890	+ 1.13421	+ 1.19176
0.25	+ 1.03246	+ 1.09991	+ 1.17082	+ 1.24535
0.30	+ 1.03926	+ 1.12145	+ 1.20876	+ 1.30143
0.35	+ 1.04616	+ 1.14356	+ 1.24806	+ 1.36009
0.40	+ 1.05318	+ 1.16625	+ 1.28879	+ 1.42147
0.45	+ 1.06030	+ 1.18952	+ 1.33101	+ 1.48570
0.50	+ 1.06753	+ 1.21341	+ 1.37475	+ 1.55306
0.55	+ 1.07489	+ 1.23793	+ 1.42010	+ 1.62322
0.60	+ 1.08236	+ 1.26310	+ 1.46710	+ 1.69681
0.65	+ 1.08995	+ 1.28894	+ 1.51583	+ 1.77381
0.70	+ 1.09767	+ 1.31547	+ 1.56635	+ 1.85440
0.75	+ 1.10551	+ 1.34271	+ 1.61873	+ 1.93873
0.80	+ 1.11348	+ 1.37068	+ 1.67304	+ 2.02700
0.85	+ 1.12158	+ 1.39941	+ 1.72937	+ 2.11938
0.90	+ 1.12982	+ 1.42892	+ 1.78778	+ 2.21606
0.95	+ 1.13820	+ 1.45923	+ 1.84836	+ 2.31726
1.0	+ 1.14672	+ 1.49037	+ 1.91120	+ 2.42318
1.1	+ 1.16420	+ 1.55524	+ 2.04401	+ 2.65011
1.2	+ 1.18228	+ 1.62374	+ 2.18696	+ 2.89877
1.3	+ 1.20099	+ 1.69612	+ 2.34088	+ 3.17128
1.4	+ 1.22038	+ 1.77262	+ 2.50666	+ 3.46996
1.5	+ 1.24045	+ 1.85351	+ 2.68526	+ 3.79736
1.6	+ 1.26126	+ 1.93907	+ 2.87772	+ 4.15627
1.7	+ 1.28283	+ 2.02961	+ 3.08520	+ 4.54978
1.8	+ 1.30520	+ 2.12546	+ 3.30891	+ 4.98126
1.9	+ 1.32841	+ 2.22697	+ 3.55020	+ 5.45442
2.0	+ 1.35251	+ 2.33452	+ 3.81052	+ 5.97334
2.2	+ 1.40352	+ 2.56938	+ 4.39470	+ 7.16685
2.4	+ 1.45863	+ 2.83362	+ 5.07576	+ 8.60321
2.6	+ 1.51826	+ 3.13139	+ 5.87057	+ 10.3325
2.8	+ 1.58288	+ 3.46744	+ 6.79907	+ 12.4151
3.0	+ 1.65306	+ 3.84727	+ 7.88479	+ 14.9240
3.5	+ 1.85692	+ 5.03239	+ 11.4822	+ 23.6873
4.0	+ 2.11124	+ 6.66263	+ 16.8440	+ 37.6855
4.5	+ 2.43201	+ 8.92432	+ 24.8768	+ 60.0835
5.0	+ 2.84105	+ 12.0875	+ 36.9683	+ 95.9765
5.5	+ 3.36907	+ 16.5491	+ 55.2626	+ 153.612
6.0	+ 4.05506	+ 22.8728	+ 83.0012	+ 246.127
6.5	+ 4.95887	+ 31.9154	+ 125.288	+ 395.013
7.0	+ 6.16010	+ 44.9201	+ 189.947	+ 634.784
7.5	+ 7.77180	+ 63.7342	+ 289.135	+ 1021.30
8.0	+ 9.95380	+ 91.1045	+ 441.744	+ 1644.94

M ($\alpha . 4 . x$)

x	$\alpha = -\frac{1}{2}$	$\alpha = -\frac{3}{2}$	$\alpha = -\frac{5}{2}$	$\alpha = -\frac{7}{2}$
0.00	+ 1.00000	+ 1.00000	+ 1.00000	+ 1.00000
0.02	+ 0.99750	+ 0.99251	+ 0.98754	+ 0.98259
0.04	+ 0.99500	+ 0.98503	+ 0.97515	+ 0.96535
0.06	+ 0.99248	+ 0.97757	+ 0.96284	+ 0.94828
0.08	+ 0.98996	+ 0.97012	+ 0.95060	+ 0.93139
0.10	+ 0.98744	+ 0.96269	+ 0.93843	+ 0.91467
0.15	+ 0.98111	+ 0.94417	+ 0.90835	+ 0.87361
0.20	+ 0.97475	+ 0.92575	+ 0.87873	+ 0.83360
0.25	+ 0.96835	+ 0.90743	+ 0.84957	+ 0.79464
0.30	+ 0.96192	+ 0.88920	+ 0.82087	+ 0.75670
0.35	+ 0.95546	+ 0.87107	+ 0.79262	+ 0.71977
0.40	+ 0.94897	+ 0.85303	+ 0.76483	+ 0.68384
0.45	+ 0.94243	+ 0.83510	+ 0.73750	+ 0.64890
0.50	+ 0.93587	+ 0.81725	+ 0.71061	+ 0.61493
0.55	+ 0.92927	+ 0.79951	+ 0.68417	+ 0.58192
0.60	+ 0.92263	+ 0.78187	+ 0.65818	+ 0.54986
0.65	+ 0.91596	+ 0.76432	+ 0.63264	+ 0.51872
0.70	+ 0.90925	+ 0.74687	+ 0.60753	+ 0.48851
0.75	+ 0.90250	+ 0.72953	+ 0.58287	+ 0.45921
0.80	+ 0.89571	+ 0.71228	+ 0.55865	+ 0.43080
0.85	+ 0.88889	+ 0.69513	+ 0.53486	+ 0.40327
0.90	+ 0.88202	+ 0.67809	+ 0.51151	+ 0.37661
0.95	+ 0.87512	+ 0.66114	+ 0.48859	+ 0.35081
1.0	+ 0.86818	+ 0.64430	+ 0.46610	+ 0.32585
1.1	+ 0.85417	+ 0.61092	+ 0.42240	+ 0.27841
1.2	+ 0.83999	+ 0.57796	+ 0.38040	+ 0.23419
1.3	+ 0.82564	+ 0.54542	+ 0.34008	+ 0.19308
1.4	+ 0.81112	+ 0.51330	+ 0.30142	+ 0.15500
1.5	+ 0.79641	+ 0.48160	+ 0.26440	+ 0.11984
1.6	+ 0.78151	+ 0.45034	+ 0.22901	+ 0.08751
1.7	+ 0.76642	+ 0.41951	+ 0.19523	+ 0.05791
1.8	+ 0.75113	+ 0.38912	+ 0.16304	+ 0.03094
1.9	+ 0.73564	+ 0.35917	+ 0.13242	+ 0.00650
2.0	+ 0.71993	+ 0.32968	+ 0.10336	- 0.01549
2.2	+ 0.68786	+ 0.27205	+ 0.04983	- 0.05251
2.4	+ 0.65485	+ 0.21629	+ 0.00230	- 0.08085
2.6	+ 0.62086	+ 0.16243	- 0.03938	- 0.10125
2.8	+ 0.58580	+ 0.11051	- 0.07537	- 0.11440
3.0	+ 0.54961	+ 0.06060	- 0.10582	- 0.12099
3.5	+ 0.45364	- 0.05511	- 0.15879	- 0.11316
4.0	+ 0.34859	- 0.15712	- 0.18077	- 0.07862
4.5	+ 0.23261	- 0.24438	- 0.17452	- 0.02683
5.0	+ 0.10333	- 0.31567	- 0.14297	+ 0.03343
5.5	- 0.04232	- 0.36964	- 0.08927	+ 0.09410
6.0	- 0.20821	- 0.40429	- 0.01672	+ 0.14778
6.5	- 0.39952	- 0.41781	+ 0.07098	+ 0.18800
7.0	- 0.62296	- 0.40759	+ 0.16990	+ 0.20904
7.5	- 0.88743	- 0.37052	+ 0.27571	+ 0.20613
8.0	- 1.20478	- 0.30279	+ 0.38363	+ 0.17548

The Exponential Integral, $Ei (\pm x)$.

Several tables* of the function $Ei (x) = \int_{-\infty}^{-x} \frac{e^{-u}}{u} du$ for both positive and negative

values of x , and of the Sine and Cosine Integrals, $Si (x) = \int_x^{\infty} \frac{\sin u}{u} du$ and $Ci (x) = -\int_x^{\infty} \frac{\cos u}{u} du$, have been published.

Dr. Glaisher's Tables give 29 values of the functions to 18 places for $x = 0.00$ to 1.00 , to 11 places for $x = 1.0$ to 5.0 by intervals of 0.1 , and for integer values from 5 to 15 ; the Sine and Cosine Integrals are also tabulated to 7 places for a number of integer values of x beyond this range.

The series in descending powers of the argument,

$$\frac{e^x}{x} \left(1 + \frac{1!}{x} + \frac{2!}{x^2} + \frac{3!}{x^3} + \frac{4!}{x^4} + \dots \right)$$

is most suitable and convenient for calculating $Ei (x)$ for large values of x . When x is negative, the signs of the terms are alternately positive and negative; in this case several places of decimals can be added to the result obtained by stopping the calculation at the least term. If $x = n + h$, the divergent part of series can be represented by the product of the least term T and the factor φ_1 , of which the first five terms are

$$\begin{aligned} & \frac{1}{2} - \frac{1}{4n} \left(\frac{1}{2} + h \right) + \frac{1}{8n^2} \left(\frac{1}{4} + \frac{h}{2} + h^2 \right) + \frac{1}{16n^3} \left(\frac{1}{8} + \frac{h}{4} - h^3 \right) \\ & - \frac{1}{32n^4} \left(\frac{13}{16} + \frac{13h}{8} + \frac{7h^2}{4} + h^3 - h^4 \right) + \dots \end{aligned}$$

For example, when $x = 11$, $\varphi_1 = 0.488898908 \dots$ and the least term of the series, $T = 0.000139905948$, the product, 0.000068399865 , is equivalent to the divergent terms. The result is, in this case, improved to the extent of eight or nine places of decimals.

If x is positive and equal to $n + \alpha$, the "converging factor" is

$$\left(\alpha - \frac{4}{3} \right) + \frac{1}{3x} \left(\frac{4}{45} - \alpha + 2\alpha^2 - \alpha^3 \right) + \frac{1}{15x} \left(\frac{8}{189} + \frac{8\alpha}{9} - \frac{47\alpha^2}{9} + \frac{25\alpha^3}{3} - 5\alpha^4 + \alpha^5 \right) + \dots$$

For $\alpha = 0$, i.e. when x is a positive integer, the second least term must be multiplied by

$$-\frac{4}{3} + \frac{4}{135n} + \frac{8}{2835n^2} - \frac{16}{8505n^3} - \dots$$

When $x = 10$, $Ei (10)$ is given to four or five significant figures when the calculation is restricted to the convergent terms of the asymptotic series; by the above method $Ei (10)$ has been computed to twenty places of decimals, giving a result in agreement with the value of the function in Bauschinger's Tables.

*Bauschinger. *Archiv der Math. u. Phys.*, 1843, pp. 28-34.

Bretschneider. *Zeit. für Math. u. Phys.*, vol. 6, 1861, pp. 127-139.

J. W. L. Glaisher. *Phil. Trans.*, vol. 160, 1870, pp. 367-387.

J. P. Gram. *Afhandlingar der Kopenhagener Akad.* (6), vol. 2, 1884, pp. 183-308.

Lord Rayleigh. *Proc. Roy. Soc.*, A, vol. 90, 1914, pp. 318-323, or Collected Papers, vol. 6, p. 228.

x	$Ei(x)$	$-Ei(-x)$
5.0	40.18527 536	0.00114 82955 913
5.1	43.27570 764	0. 102 13001 079
5.2	46.62485 051	0. 90 86216 125
5.3	50.25573 031	0. 80 86083 340
5.4	54.19347 580	0. 71 98044 499
5.5	58.46551 425	0. 64 09260 499
5.6	63.10178 598	0. 57 08401 696
5.7	68.13497 924	0. 50 85464 803
5.8	73.60078 735	0. 45 31612 835
5.9	79.53819 015	0. 40 39035 089
6.0	85.98976 214	0. 36 00824 522
6.1	93.00200 999	0. 32 10870 279
6.2	100.62574 194	0. 28 63763 442
6.3	108.91647 253	0. 25 54714 278
6.4	117.93486 570	0. 22 79479 559
6.5	127.74722 023	0. 20 34298 668
6.6	138.42600 141	0. 18 15837 393
6.7	150.05042 344	0. 16 21138 452
6.8	162.70708 757	0. 14 47577 922
6.9	176.49068 109	0. 12 92826 836
7.0	191.50474 334	0. 11 54817 316
7.1	207.86250 497	0. 10 31712 701
7.2	225.68780 770	0. 9 21881 1690
7.3	245.11611 222	0. 8 23872 4446
7.4	266.29560 282	0. 7 36397 2150
7.5	289.38839 820	0. 6 58308 9327
7.6	314.57187 850	0. 5 88587 7207
7.7	342.04014 009	0. 5 26326 1311
7.8	372.00559 032	0. 4 70716 5377
7.9	404.70069 585	0. 4 21039 9713
8.0	440.37989 954	0. 3 76656 2284
8.1	479.32172 208	0. 3 36995 1046
8.2	521.83106 662	0. 3 01548 6215
8.3	568.24174 579	0. 2 69864 1334
8.4	618.91925 296	0. 2 41538 2105
8.5	674.26380 152	0. 2 16211 2104
8.6	734.71365 808	0. 1 93562 4583
8.7	800.74879 849	0. 1 73305 9664
8.8	872.89491 793	0. 1 55186 6315
8.9	951.72782 971	0. 1 38976 8555
9.0	1037.87829 07	0. 1 24473 5418
9.1	1132.03729 51	0. 1 11495 4242
9.2	1234.96188 18	0. 99880 6919
9.3	1347.48150 67	0. 89484 8755
9.4	1470.50503 39	0. 80178 9673
9.5	1605.02840 66	0. 71847 7469
9.6	1752.14306 55	0. 64388 2915
9.7	1913.04518 55	0. 57708 6483
9.8	2089.04581 35	0. 51726 6533
9.9	2281.58199 33	0. 46368 8776
10.0	2492.22897 62	0. 41569 6893

x	$Ei(x)$	$-Ei(-x)$
10.1	2722.71362 2	0.00000 37270 4173
10.2	2974.92911 0	0. 33418 6054
10.3	3250.95108 4	0. 29967 3477
10.4	3553.05537 6	0. 26874 6958
10.5	3883.73746 5	0. 24103 1296
10.6	4245.73383 7	0. 21619 0858
10.7	4642.04543 3	0. 19392 5368
10.8	5075.96339 4	0. 17396 6147
10.9	5551.09733 5	0. 15607 2762
11.0	6071.40637 4	0. 14003 0030
11.1	6641.23321 8	0. 12564 5346
11.2	7265.34158 5	0. 11274 6289
11.3	7948.95729 5	0. 10117 8495
11.4	8697.81340 3	0. 9080 3751
11.5	9518.19976 0	0. 8149 8288
11.6	10417.01743 9	0. 7315 1262
11.7	11401.83851 9	0. 6566 3397
11.8	12480.97173 8	0. 5894 5763
11.9	13663.53461 7	0. 5291 8695
12.0	14959.53266 6	0. 4751 0818
12.1	16379.94640	0. 4265 8180
12.2	17936.82693	0. 3830 3473
12.3	19643.40095	0. 3439 5340
12.4	21514.18607	0. 3088 7750
12.5	23565.11759	0. 2773 9445
12.6	25813.68767	0. 2491 3443
12.7	28279.09832	0. 2237 6585
12.8	30982.42945	0. 2009 9146
12.9	33946.82354	0. 1805 4472
13.0	37197.68849	0. 1621 8662
13.1	40762.92065	0. 1457 0282
13.2	44673.14972	0. 1309 0110
13.3	48962.00804	0. 1176 0903
13.4	53666.42637	0. 1056 7197
13.5	58826.95908	0. 949 5118
13.6	64488.14140	0. 853 2220
13.7	70698.88214	0. 766 7338
13.8	77512.89528	0. 689 0452
13.9	84989.17431	0. 619 2572
14.0	93192.51363	0. 556 5631
14.1	102194.08162	0. 500 2389
14.2	112072.05053	0. 449 6349
14.3	122912.28891	0. 404 1679
14.4	134809.12276	0. 363 3143
14.5	147866.17221	0. 326 6043
14.6	162197.27131	0. 293 6160
14.7	177927.47920	0. 263 9707
14.8	195194.19178	0. 237 3284
14.9	214148.36378	0. 213 3838
15.0	234955.85249	0. 191 8628

The Sine and Cosine Integrals, Si (x) and Ci (x).

For large values of the argument x , the Sine and Cosine Integrals were calculated from the asymptotic expansions of these functions.

$$\begin{aligned} \text{Si}(x) &= \frac{\pi}{2} - \frac{\cos x}{x} \left(1 - \frac{2!}{x^2} + \frac{4!}{x^4} - \frac{6!}{x^6} + \dots \right) \\ &\quad - \frac{\sin x}{x} \left(\frac{1!}{x} - \frac{3!}{x^3} + \frac{5!}{x^5} - \frac{7!}{x^7} + \dots \right) \\ \text{and Ci}(x) &= \frac{\sin x}{x} \left(1 - \frac{2!}{x^2} + \frac{4!}{x^4} - \frac{6!}{x^6} + \dots \right) \\ &\quad - \frac{\cos x}{x} \left(\frac{1!}{x} - \frac{3!}{x^3} + \frac{5!}{x^5} - \frac{7!}{x^7} + \dots \right) \end{aligned}$$

For the series, $1 - \frac{2!}{x^2} + \frac{4!}{x^4} - \frac{6!}{x^6} + \dots$, when $2x = 2n + \alpha$, the 'converging factor' is

$$\frac{1}{2} + \frac{1}{4n} (1 - 2\alpha) - \frac{1}{8n^2} (1 - 5\alpha) - \frac{1}{16n^3} (3 + 20\alpha - \alpha^2 - 2\alpha^3) \dots$$

and for the series $\frac{1!}{x} - \frac{3!}{x^3} + \frac{5!}{x^5} - \frac{7!}{x^7} + \dots$, when $2x = 2n + \alpha$, $\frac{1}{2} - \frac{1}{4n} (1 + 2\alpha) + \frac{3}{8n^2} (1 + \alpha) - \frac{1}{16n^3} (13 + 4\alpha - 7\alpha^2 - 2\alpha^3) \dots$

The following tables of Si (x) and Ci (x) from $x = 5.0$ to 20.0 have been employed in tabulating derivatives of Bessel functions,* viz.,

$$\begin{aligned} \left[\frac{\delta}{\delta v} J_v(x) \right]_{v=\frac{1}{2}} &= J_{\frac{1}{2}}(x) \text{Ci}(2x) - J_{-\frac{1}{2}}(x) \text{Si}(2x) \\ \text{and } \left[\frac{\delta}{\delta v} J_v(x) \right]_{v=-\frac{1}{2}} &= J_{-\frac{1}{2}}(x) \text{Ci}(2x) + J_{\frac{1}{2}}(x) \text{Si}(2x). \end{aligned}$$

Schafheitlin† also gives an interesting relation between these derivatives and the Sine and Cosine Integrals.

* Ansell and Fisher. "Note on the numerical evaluation of a Bessel function derivative." *Proc. Lond. Math. Soc.*, vol. 24, 1926.

† Schafheitlin. *Sitzungsber. Berlin. Math. Ges.*, vol. 8, 1909, pp. 62-67.

x	$\text{Si}(x)$	$\text{Ci}(x)$
5.0	+ 1.54993 12449	- 0.19002 97497
5.1	+ 1.53125 32047	- 0.18347 62632
5.2	+ 1.51367 09468	- 0.17525 36023
5.3	+ 1.49371 50636	- 0.16550 59586
5.4	+ 1.48230 00826	- 0.15438 59262
5.5	+ 1.46872 40727	- 0.14205 29475
5.6	+ 1.45666 83847	- 0.12867 17494
5.7	+ 1.44619 75285	- 0.11441 07808
5.8	+ 1.43735 91823	- 0.09944 06647
5.9	+ 1.43018 43341	- 0.08393 26741
6.0	+ 1.42468 75513	- 0.06805 72439
6.1	+ 1.42086 73734	- 0.05198 25290
6.2	+ 1.41870 68241	- 0.03587 30193
6.3	+ 1.41817 40348	- 0.01988 82206
6.4	+ 1.41922 29740	- 0.00418 14110
6.5	+ 1.42179 42744	+ 0.01110 15195
6.6	+ 1.42581 61486	+ 0.02582 31381
6.7	+ 1.43120 53853	+ 0.03985 54400
6.8	+ 1.43786 84161	+ 0.05308 07167
6.9	+ 1.44570 24427	+ 0.06539 23140
7.0	+ 1.45459 66142	+ 0.07669 52785
7.1	+ 1.46443 32441	+ 0.08690 68881
7.2	+ 1.47508 90554	+ 0.09595 70643
7.3	+ 1.48643 64451	+ 0.10378 86664
7.4	+ 1.49834 47533	+ 0.11035 76658
7.5	+ 1.51068 15309	+ 0.11563 32032
7.6	+ 1.52331 37914	+ 0.11959 75293
7.7	+ 1.53610 92381	+ 0.12224 58319
7.8	+ 1.54893 74581	+ 0.12358 59542
7.9	+ 1.56167 10702	+ 0.12363 80071
8.0	+ 1.57418 68217	+ 0.12243 38825
8.1	+ 1.58636 66225	+ 0.12001 66733
8.2	+ 1.59809 85106	+ 0.11644 00055
8.3	+ 1.60927 75419	+ 0.11176 72931
8.4	+ 1.61980 65968	+ 0.10607 09196
8.5	+ 1.62959 70996	+ 0.09943 13586
8.6	+ 1.63856 96454	+ 0.09193 62396
8.7	+ 1.64665 45309	+ 0.08367 93696
8.8	+ 1.65379 21860	+ 0.07475 97196
8.9	+ 1.65993 35052	+ 0.06528 03850
9.0	+ 1.66504 00758	+ 0.05534 75313
9.1	+ 1.66908 43056	+ 0.04506 93325
9.2	+ 1.67204 94480	+ 0.03455 49134
9.3	+ 1.67392 95283	+ 0.02391 33045
9.4	+ 1.67472 91725	+ 0.01325 24187
9.5	+ 1.67446 33423	+ 0.00267 80588
9.6	+ 1.67315 69801	- 0.00770 70361
9.7	+ 1.67084 45697	- 0.01780 40977
9.8	+ 1.66756 96169	- 0.02751 91811
9.9	+ 1.66338 40566	- 0.03676 39563
10.0	+ 1.65834 75942	- 0.04545 64330
10.1	+ 1.65252 69863	- 0.05352 16129
10.2	+ 1.64599 52699	- 0.06089 20650
10.3	+ 1.63883 09477	- 0.06750 84193
10.4	+ 1.63111 71372	- 0.07331 97774

x	Si (x)	Ci (x)
10.5	+ 1.62294 06928	- 0.07828 40360
10.6	+ 1.61439 13081	- 0.08236 81222
10.7	+ 1.60556 06086	- 0.08554 81414
10.8	+ 1.59654 12420	- 0.08780 94350
10.9	+ 1.58742 59756	- 0.08914 65523
11.0	+ 1.57830 68070	- 0.08956 31355
11.1	+ 1.56927 40993	- 0.08907 17213
11.2	+ 1.56041 57452	- 0.08769 34631
11.3	+ 1.55181 63692	- 0.08545 77762
11.4	+ 1.54355 65739	- 0.08240 19115
11.5	+ 1.53571 22370	- 0.07857 04624
11.6	+ 1.52835 38648	- 0.07401 48108
11.7	+ 1.52154 60065	- 0.06879 25181
11.8	+ 1.51534 67354	- 0.06296 66674
11.9	+ 1.50980 71987	- 0.05660 51650
12.0	+ 1.50497 12415	- 0.04978 00069
12.1	+ 1.50087 51047	- 0.04256 65182
12.2	+ 1.49754 72009	- 0.03504 25738
12.3	+ 1.49500 79674	- 0.02728 78062
12.4	+ 1.49326 97981	- 0.01938 28102
12.5	+ 1.49233 70523	- 0.01140 83496
12.6	+ 1.49220 61397	- 0.00344 45755
12.7	+ 1.49286 56808	+ 0.00442 97378
12.8	+ 1.49429 67377	+ 0.01213 79323
12.9	+ 1.49647 31146	+ 0.01960 61745
13.0	+ 1.49936 17229	+ 0.02676 41256
13.1	+ 1.50292 30057	+ 0.03354 51517
13.2	+ 1.50711 14191	+ 0.03988 85695
13.3	+ 1.51187 59633	+ 0.04573 80870
13.4	+ 1.51716 07571	+ 0.05104 22716
13.5	+ 1.52290 56528	+ 0.05575 70387
13.6	+ 1.52904 68810	+ 0.05984 43271
13.7	+ 1.53551 77245	+ 0.06327 27908
13.8	+ 1.54224 91979	+ 0.06601 80057
13.9	+ 1.54917 07698	+ 0.06806 26067
14.0	+ 1.55621 10501	+ 0.06939 63559
14.1	+ 1.56329 85047	+ 0.07001 61408
14.2	+ 1.57036 21513	+ 0.06992 59037
14.3	+ 1.57733 22411	+ 0.06913 65055
14.4	+ 1.58414 09199	+ 0.06766 55230
14.5	+ 1.59072 28621	+ 0.06553 69861
14.6	+ 1.59701 58712	+ 0.06278 10551
14.7	+ 1.60296 14427	+ 0.05943 36438
14.8	+ 1.60850 52840	+ 0.05553 59920
14.9	+ 1.61359 77858	+ 0.05113 41927
15.0	+ 1.61819 44437	+ 0.04627 86777
15.1	+ 1.62225 62235	+ 0.04102 36693
15.2	+ 1.62574 98701	+ 0.03542 66015
15.3	+ 1.62864 81558	+ 0.02954 75181
15.4	+ 1.63093 00674	+ 0.02344 84533
15.5	+ 1.63258 09314	+ 0.01719 28004
15.6	+ 1.63359 24753	+ 0.01084 46765
15.7	+ 1.63396 28269	+ 0.00446 82867
15.8	+ 1.63369 64514	- 0.00187 27032
15.9	+ 1.63280 40282	- 0.00811 57823

x	$Si(x)$	$Ci(x)$
16.0	+ 1.63130 22683	- 0.01420 01901
16.1	+ 1.62921 36765	- 0.02006 74889
16.2	+ 1.62656 62595	- 0.02566 21059
16.3	+ 1.62339 31849	- 0.03093 18413
16.4	+ 1.61973 23933	- 0.03582 83375
16.5	+ 1.61562 61697	- 0.04030 75052
16.6	+ 1.61112 06774	- 0.04432 99037
16.7	+ 1.60626 54599	- 0.04786 10702
16.8	+ 1.60111 29152	- 0.05087 17985
16.9	+ 1.59571 77500	- 0.05333 83622
17.0	+ 1.59013 64159	- 0.05524 26823
17.1	+ 1.58442 65368	- 0.05657 24381
17.2	+ 1.57864 63308	- 0.05732 11212
17.3	+ 1.57285 40326	- 0.05748 80314
17.4	+ 1.56710 73231	- 0.05707 82170
17.5	+ 1.56146 27703	- 0.05610 23592
17.6	+ 1.55597 52875	- 0.05457 66039
17.7	+ 1.55069 76135	- 0.05252 23406
17.8	+ 1.54567 98202	- 0.04996 59346
17.9	+ 1.54096 88514	- 0.04693 84117
18.0	+ 1.53660 80969	- 0.04347 51030
18.1	+ 1.53263 70060	- 0.03961 52498
18.2	+ 1.52909 07445	- 0.03540 15759
18.3	+ 1.52599 98956	- 0.03087 98300
18.4	+ 1.52339 02103	- 0.02609 83036
18.5	+ 1.52128 24067	- 0.02110 73295
18.6	+ 1.51969 20207	- 0.01595 87655
18.7	+ 1.51862 93088	- 0.01070 54687
18.8	+ 1.51809 92044	- 0.00540 07658
18.9	+ 1.51810 13248	- 0.00009 79242
19.0	+ 1.51863 00318	+ 0.00515 03710
19.1	+ 1.51967 45419	+ 0.01029 25282
19.2	+ 1.52121 90863	+ 0.01527 85452
19.3	+ 1.52324 31171	+ 0.02006 04841
19.4	+ 1.52572 15595	+ 0.02459 29217
19.5	+ 1.52862 51042	+ 0.02883 33693
19.6	+ 1.53192 05393	+ 0.03274 26615
19.7	+ 1.53557 11167	+ 0.03628 53073
19.8	+ 1.53953 69490	+ 0.03942 98014
19.9	+ 1.54377 54340	+ 0.04214 88951
20.0	+ 1.54824 17010	+ 0.04441 98208

Zeros of Bessel Functions of small fractional order.

The first zero, ρ_1 of $J_\nu(x)$, was calculated from the relation

$$\sum \rho_s^{-10} = \frac{7\nu+19}{2^9(\nu+1)^5(\nu+2)^2(\nu+3)(\nu+4)(\nu+5)}$$

When ν is small, approximate values of ρ_2 and ρ_3 are sufficient to give the value of ρ_1 to five places of decimals. If $\nu = -1 + \alpha$ and α is less than 0.15, then to five places of decimals,

$$\rho_1 = 2\alpha^{\frac{1}{2}} \left(1 + \frac{1}{4}\alpha - \frac{1}{96}\alpha^2 + \frac{49}{1152}\alpha^3 - \dots \right)$$

A short table* of the zeros to four places for the range $\nu = -\frac{1}{2}$ to 1 was published some years ago.

* J. R. Airey. "Bessel functions of small fractional order and their application to problems of Elastic Stability." *Phil. Mag.*, vol. 41, 1921, pp. 200-205.

Zero ρ_1 of the Bessel Function, $J_\nu(x)$.

ν	ρ_1	ν	ρ_1	ν	ρ_1	ν	ρ_1
-1.00	0.00000	-0.50	1.57079 :	+0.00	2.40482 :	+0.50	3.14159 :
-0.99	0.20050	-0.49	1.58926	+0.01	2.42023 :	+0.51	3.15576 :
-0.98	0.28425	-0.48	1.60762	+0.02	2.43561 :	+0.52	3.16992 :
-0.97	0.34898 :	-0.47	1.62587	+0.03	2.45095 :	+0.53	3.18405 :
-0.96	0.40395 :	-0.46	1.64402	+0.04	2.46626 :	+0.54	3.19817 :
-0.95	0.45272 :	-0.45	1.66207 :	+0.05	2.48154 :	+0.55	3.21228 :
-0.94	0.49712	-0.44	1.68003 :	+0.06	2.49679	+0.56	3.22636 :
-0.93	0.53823	-0.43	1.69790	+0.07	2.51200	+0.57	3.24043 :
-0.92	0.57674 :	-0.42	1.71568	+0.08	2.52718	+0.58	3.25449
-0.91	0.61316 :	-0.41	1.73337	+0.09	2.54233	+0.59	3.26852 :
-0.90	0.64783	-0.40	1.75097 :	+0.10	2.55745	+0.60	3.28254 :
-0.89	0.68101 :	-0.39	1.76850	+0.11	2.57254	+0.61	3.29655
-0.88	0.71292 :	-0.38	1.78594 :	+0.12	2.58760	+0.62	3.31053 :
-0.87	0.74372	-0.37	1.80331	+0.13	2.60263	+0.63	3.32451
-0.86	0.77353 :	-0.36	1.82060	+0.14	2.61763 :	+0.64	3.33846 :
-0.85	0.80247 :	-0.35	1.83781 :	+0.15	2.63261	+0.65	3.35241
-0.84	0.83063	-0.34	1.85496	+0.16	2.64755 :	+0.66	3.36633 :
-0.83	0.85808 :	-0.33	1.87203 :	+0.17	2.66247	+0.67	3.38024 :
-0.82	0.88489 :	-0.32	1.88904	+0.18	2.67736 :	+0.68	3.39414 :
-0.81	0.91112	-0.31	1.90598	+0.19	2.69223	+0.69	3.40802 :
-0.80	0.93680 :	-0.30	1.92285 :	+0.20	2.70707	+0.70	3.42189
-0.79	0.96200	-0.29	1.93966	+0.21	2.72188 :	+0.71	3.43574 :
-0.78	0.98673 :	-0.28	1.95641 :	+0.22	2.73667	+0.72	3.44958
-0.77	1.01104 :	-0.27	1.97310	+0.23	2.75143 :	+0.73	3.46340 :
-0.76	1.03496	-0.26	1.98973	+0.24	2.76617 :	+0.74	3.47721 :
-0.75	1.05851	-0.25	2.00630	+0.25	2.78088 :	+0.75	3.49101
-0.74	1.08171	-0.24	2.02281 :	+0.26	2.79557 :	+0.76	3.50479
-0.73	1.10458 :	-0.23	2.03927	+0.27	2.81024	+0.77	3.51855 :
-0.72	1.12716	-0.22	2.05567 :	+0.28	2.82488 :	+0.78	3.53231
-0.71	1.14944	-0.21	2.07202 :	+0.29	2.83950	+0.79	3.54605
-0.70	1.17145 :	-0.20	2.08832 :	+0.30	2.85409 :	+0.80	3.55978

v	ρ ₁	v	ρ ₁	v	ρ ₁	v	ρ ₁
-0.69	1.19321	-0.19	2.10457 :	+0.31	2.86867	+0.81	3.57349 :
-0.68	1.21472	-0.18	2.12077	+0.32	2.88322	+0.82	3.58719 :
-0.67	1.23600	-0.17	2.13692	+0.33	2.89775	+0.83	3.60088 :
-0.66	1.25706	-0.16	2.15302	+0.34	2.91225 :	+0.84	3.61456
-0.65	1.27791 :	-0.15	2.16907 :	+0.35	2.92674	+0.85	3.62822
-0.64	1.29856 :	-0.14	2.18508 :	+0.36	2.94120 :	+0.86	3.64187
-0.63	1.31902 :	-0.13	2.20105	+0.37	2.95564 :	+0.87	3.65551
-0.62	1.33930	-0.12	2.21696 :	+0.38	2.97007	+0.88	3.66913 :
-0.61	1.35940 :	-0.11	2.23284 :	+0.39	2.98447	+0.89	3.68275
-0.60	1.37934	-0.10	2.24867 :	+0.40	2.99885	+0.90	3.69635
-0.59	1.39911 :	-0.09	2.26447	+0.41	3.01321	+0.91	3.70993 :
-0.58	1.41873 :	-0.08	2.28022	+0.42	3.02755	+0.92	3.72351 :
-0.57	1.43820 :	-0.07	2.29593	+0.43	3.04187	+0.93	3.73708
-0.56	1.45753 :	-0.06	2.31160	+0.44	3.05617 :	+0.94	3.75063
-0.55	1.47673	-0.05	2.32723	+0.45	3.07045 :	+0.95	3.76417
-0.54	1.49579	-0.04	2.34282	+0.46	3.08472	+0.96	3.77770
-0.53	1.51472	-0.03	2.35838	+0.47	3.09896 :	+0.97	3.79122
-0.52	1.53353	-0.02	2.37389 :	+0.48	3.11319 :	+0.98	3.80472 :
-0.51	1.55222	-0.01	2.38938	+0.49	3.12740	+0.99	3.81822
-0.50	1.57079 :	-0.00	2.40482 :	+0.50	3.14159 :	+1.00	3.83170 :

Zeros of Ber, Bei, and other Functions.

In series of descending powers of x , Ber x contains the factor $\cos \delta$, where

$$\delta = \frac{x}{\sqrt{2}} - \frac{1}{8x\sqrt{2}} - \frac{1}{16x^2} - \frac{25}{384x^3\sqrt{2}} + \dots$$

If $\delta = \frac{2n-1}{2} \cdot \pi$,

$$x = \left(\frac{2n-1}{2} + \frac{1}{8}\right)\pi\sqrt{2} + \frac{1}{8x} + \frac{\sqrt{2}}{16x^2} + \frac{25}{384x^3} - \dots$$

If $x = \beta + \frac{p}{x} + \frac{q}{x^2} + \frac{r}{x^3} + \frac{s}{x^4} + \dots$, then by Lagrange's Theorem,

$$x = \beta + \frac{p}{\beta} + \frac{q}{\beta^2} + \frac{r-p^2}{\beta^3} + \frac{s-3pq}{\beta^4} + \dots$$

If $\beta = \left(\frac{2n-1}{2} + \frac{1}{8}\right)\pi\sqrt{2}$, the zeros of Ber x are given by

$$\rho_n = \beta + \frac{1}{8\beta} + \frac{\sqrt{2}}{16\beta^2} + \frac{19}{384\beta^3} - \frac{3\sqrt{2}}{128\beta^4} - \frac{3899}{15360\beta^5} - \dots$$

For the zeros of Bei x , $\beta = \left(n + \frac{1}{8}\right)\pi\sqrt{2}$

For Ker x , $\beta = \left(\frac{2n-1}{2} - \frac{1}{8}\right)\pi\sqrt{2}$

and for Kei x , $\beta = \left(n - \frac{1}{8}\right)\pi\sqrt{2}$.

The zeros of the functions Ber' x , Bei' x , etc., are given by

$$\rho_n = \gamma - \frac{3}{8\gamma} - \frac{3\sqrt{2}}{16\gamma^2} - \frac{39}{128\gamma^3} - \frac{27\sqrt{2}}{128\gamma^4} - \frac{621}{5120\gamma^5} + \dots$$

$$\text{For Ber}'x, \gamma = \left(\frac{2n+1}{2} - \frac{1}{8}\right) \pi \sqrt{2}$$

$$\text{Bei}'x, \gamma = \left(n - \frac{1}{8}\right) \pi \sqrt{2}$$

$$\text{Ker}'x, \gamma = \left(\frac{2n-1}{2} + \frac{1}{8}\right) \pi \sqrt{2}$$

$$\text{Kei}'x, \gamma = \left(n + \frac{1}{8}\right) \pi \sqrt{2}$$

These formulæ cannot be usefully employed in the calculation of the smallest zeros of these functions. In the case of Ber x , ρ_1 is found from the relation

$$\sum \rho_s^{-12} = \frac{1857}{2^{106} 1^2}$$

A similar method was adopted in calculating ρ_1 for the other functions.

First ten zeros of

Ber x	Bei x	Ker x	Kei x
2.84891 :	5.02622	1.71854 :	3.91467
7.23883	9.45541	6.12728	8.34422 :
11.67396 :	13.89349	10.56294	12.78256
16.11356 :	18.33398 :	15.00269	17.22314 :
20.55463	22.77544	19.44381 :	21.66464
24.99636 :	27.21737 :	23.88558	26.10660
29.43845	31.65958	28.32768 :	30.54882
33.88075	36.10195 :	32.76999 :	34.99120 :
38.32319	40.54444 :	37.21244	39.43370
42.76572	44.98701 :	41.65498	43.87627 :

First ten zeros of

Ber' x	Bei' x	Ker' x	Kei' x
6.03871	3.77320	2.66584	4.93181
10.51364 :	8.28099	7.17212	9.40405 :
14.96844 :	12.74215	11.63218 :	13.85827
19.41758	17.19343	16.08312	18.30717 :
23.86430 :	21.64114 :	20.53068	22.75379
28.30979 :	26.08716 :	24.97661 :	27.19922
32.75456	30.53225	29.42165 :	31.64395
37.19887	34.97676	33.86613 :	36.08823 :
41.64286 :	39.42090	38.31025 :	40.53221 :
46.08664 :	43.86478	42.75412	44.97598

Investigation of the Upper Atmosphere.—*Report of Committee* (Sir NAPIER SHAW, *Chairman*; Mr. C. J. P. CAVE, *Secretary*; Prof. S. CHAPMAN, Mr. J. S. DINES, Mr. L. H. G. DINES, Mr. W. H. DINES, Dr. G. M. B. DOBSON, Commr. L. G. GARBETT, Sir R. T. GLAZEBROOK, Col. E. GOLD, Dr. H. JEFFREYS, Dr. H. KNOX SHAW, Sir J. LARMOR, Mr. R. G. K. LEMPFERT, Prof. F. A. LINDEMANN, Dr. W. MAKOWER, Mr. J. PATTERSON, Sir J. E. PETAVEL, Sir A. SCHUSTER, Dr. G. C. SIMPSON, Sir G. T. WALKER, Mr. F. J. W. WHIPPLE, Prof. H. H. TURNER).

THE Committee was originally constituted in 1901 to co-operate with the Royal Meteorological Society. It was in abeyance from 1915 until it was reconstituted in 1920. It presented a report at the meeting at Hull in 1922 in which the main principle for the operations of the Committee was 'the desirability of inviting the co-operation and interco-operation not only of Directors of Institutes and Observatories but also of Scientific Academies and Societies in the study of the upper air.'

In its report the Committee mentioned that, at its suggestion, a resolution had been brought before the Meteorological Section of the British National Committee and passed on to the Meteorological Section of the International Union for Geodesy and Geophysics with suggestions as to procedure in the development of the plan. It was thought by the officers of the Committee that the Meteorological Section of the British National Committee might take over the work from the British Association; but the Committee thought otherwise and in June 1923 decided that as the study of the upper air was only a part of meteorology the preferable course was to promote the co-operation of the various voluntary agencies interested therein, namely the Meteorological Section of the National Committee, the Royal Meteorological Society and the British Association in a joint committee for the upper air.

The special objects which the Committee then had in view were a pamphlet of instructions for observers in the use of (1) ballons-sondes at sea, and (2) pilot-balloons of long carry, with a view to observations at sea and in the less frequented parts of the world.

At the meeting of the Meteorological Section of the Union for Geodesy and Geophysics at Rome funds were allocated for the objects which the Committee had recommended, and with them were also joined an international investigation of dust in the atmosphere, the composition of the atmosphere above 20 kilometres, and the problem of solar radiation, all of which are closely interrelated with the more ordinary features of the exploration of the upper air.

Solar and Terrestrial Radiation.

For the last two years the Committee's attention has been directed towards solar and terrestrial radiation, which must always be regarded as the fundamental problem of meteorology and of primary importance for any effective investigation of the upper air.

The Committee was glad to see a résumé by one of its own members of the results of observations of solar radiation at 59 stations in various parts of the globe which formed an Annexe to the report of the meeting of the Meteorological Section of the U.G.G.I. at Madrid. It recognises that a summary of the present state of our knowledge of the subject is much needed and has learned with satisfaction that the Meteorological Section of the British National Committee is taking steps to secure that the issues of the sections of the U.G.G.I. which contain data of the kind indicated may be made more generally accessible for the scientific reader. The Committee is also informed that our knowledge of solar and terrestrial radiation is treated as the basis of the science of meteorology in a Manual by Sir Napier Shaw, now in course of publication. It awaits with interest the development of that part of the subject which deals with the relation of solar and terrestrial radiation in different wave lengths.

In 1925 a grant of £38 was obtained for a self-recording radiometer and in connection therewith the co-operation of the Royal Meteorological Society was revived; the subjects are now under the consideration of a joint committee of the two bodies. The instrument was acquired at a cost of £60, to which £17 was contributed by the Royal Meteorological Society and £5 by a member of the Committee. The cost of

installation at the School of Agriculture at Cambridge was borne by Mr. C. S. Leaf of Trinity College. The Committee is not yet in a position to report on the behaviour of the instrument.

At the meeting of the Association at Oxford in 1926 a grant of £70 was obtained to aid in promoting the study of the relation of solar and terrestrial radiation by making an apparatus designed by Mr. W. H. Dines generally available for that purpose. The price quoted was contingent upon finding purchasers for a number of the instruments to be made at the same time. The Committee, however, have found themselves unable to apply for the grant made at Oxford, and there is no immediate prospect of being able to utilise it in the way proposed.

Investigations by Members of the Committee.

The Committee is, however, of opinion that although organised co-operative work had so far not been found practicable, the progress made by individual members of the Committee was sufficiently encouraging for the endeavour to be continued. At the suggestion of the Committee Mr. L. H. G. Dines has refurnished the Dines meteorograph with a recording pen for humidity. The pamphlet of directions for observations at sea is now available, for ballons-sondes by the translation of the exposé technique of Teisserenc de Bort and Rotch, and for pilot-balloons at sea by a special issue of the Air Ministry. With the assistance of the Hydrographer, Commander L. G. Garbett, Superintendent of Naval Meteorological Services, has secured a considerable extension in the use of pilot-balloons at sea, and is still engaged upon work with ballons-sondes. It is gratifying that H.M.S. *Repulse*, carrying the Prince of Wales, and H.M.S. *Renown*, carrying the Duke and Duchess of York, are enrolled in the list of co-operators in the study of the upper air.

The compilation of the observations of the upper air on the international days of 1923, which is now completed as a specimen volume for the International Commission for the Exploration of the Upper Air, is in itself a voluntary contribution of some importance, especially as, by instruction of the International Commission for the Exploration of the Upper Air, the compilation is expressed in units which bring meteorology into line with other geophysical sciences as part of a common system. The Committee has recorded its congratulations to the editors of the work on its completion.

In the specimen volume referred to is found the first general application of the indicator-diagrams representing the results of observations of pressure and temperature in the upper air by a curve referred to entropy and temperature as co-ordinates and now known as tephigrams. They also form an important contribution to the subject because they add materially to the effective expression of the thermodynamics of the atmosphere. The Committee has watched their development through all its stages. The introduction of the values of geopotential into the diagrams adds materially to their interest.

In other directions also there has been marked progress—the question of the composition of the upper air was raised by a member of the Commission some years ago; upon his contribution was based a resolution of the Meteorological Section of the U.G.G.I to invite the possessors of cryogenic apparatus to examine the atmosphere from time to time to determine whether the hydrogen content was a fixed or variable component. The question has been raised in a new way by the discussion of the origin of the green auroral line and the conclusion of Prof. McLennan that a mixture of nitrogen and oxygen extends far beyond the limit where they were supposed to have been displaced by helium and hydrogen.

Further light is also thrown upon the composition of the levels of the atmosphere beyond the usual meteorological limit by the work of Prof. Lindemann and Dr. G. M. B. Dobson on meteors and by Dr. Dobson's measurements of the amount of ozone.

Among other questions in relation to the upper air (in the meteorological sense) which are of interest to members of the British Association, mention ought to be made of the transmission of sound waves to distances so great as to require the assistance of excessive refraction in the upper layers. Mr. Whipple was the first to propound the idea that this 'abnormal' propagation of sound to great distances was to be explained by postulating a warm layer of air at a considerable height, such as was required for the Lindeman-Dobson theory of meteors, but the layer would have to be lower than those authors required, say at 40 instead of at 60 kilometres.

Mr. Whipple has recently organised observations of the time of passage of air waves from gunfire. His initial success, in January 1926, was in timing the passage of audible sound from Shoeburyness to Grantham. Recently, with the assistance of the British Broadcasting Corporation, the times of firing a gun at Shoeburyness have been broadcast, and the assistance of the public in listening has been invoked. It appears that the occasions when sound can be heard at very great distances are rare and exceptional; observations with hot wire microphones, however, have been very successful. At Birmingham University good results have been obtained at each of three trials. Correlation with meteorological data promises to prove a valuable line of research.

The counting of the dust particles by the Owens dust counter, which was one of the original suggestions of the Committee to the British National Committee, has been warmly taken up in the United States and observations have been made regularly in Australia for the Bureau of Meteorology by Dr. E. Kidson, who has now become Director of the Meteorological Service of New Zealand. In Mr. Hunt's report to the Meteorological Section Dr. Kidson raises the question of the relation of the dust count in the Owens Counter with that in the Aitken Counter, a question of interest and importance. In the United States attention was turned to the dust counts at different levels of the atmosphere as observed in balloons or aeroplanes; but the subject has not been pursued since the death of Mr. C. Le Roy Meisinger while engaged upon that inquiry. No other country has yet contributed information on that subject.

The Interest of Universities and Science Departments of Schools.

It is interesting to note that some of these researches owe much to the Universities. Dr. Dobson's work on ozone was carried out at Oxford, and his collaborators have been students in that University. Yeoman service has been rendered to Mr. Whipple's investigation of the audibility of gunfire by the Physical Departments in the Universities of Birmingham and Bristol, and in University College, Southampton.

The Committee is of opinion that there is still an opening for co-operation on the part of Universities and the Science Departments of Schools for those aspects of the investigation of the upper air which can be worked by the simultaneous action on selected occasions of moderately instructed observers over the country generally, as distinguished from the repetition of regular observations by the trained staff of the official establishments. As an example of an investigation which might be benefited by such co-operation may be cited the investigation of the structure of a typical cyclonic depression by a number of simultaneous soundings with registering balloons, supplemented by a much larger number of what may be called post card balloons.

Such an investigation, however, requires the special attention of some such body as a Committee of the British Association to prepare a detailed programme, arrange for the supply of necessary apparatus and materials, issue instructions and give notice of the selected occasion which would naturally be so chosen as to fit in with the international organisation.

If a suitable scheme could be drawn up in conjunction with the Association of Science Teachers the B.B.C. would probably not refuse its invaluable help in securing volunteers and notifying a suitable occasion.

The Committee has considered the possibility of initiating investigations of this kind.

They have in mind a project of obtaining foreshortened stereoscopic photographs of clouds by which valuable information might be obtained as to the position and dynamical condition of lenticular clouds in relation to their environment. The idea of obtaining foreshortened photographs of clouds was used with success many years ago by Mr. J. Tennant, who has sought various opportunities of developing it. It could easily be brought into general use as a co-operative exercise.

It is also thought that arrangement could be made without great expense for the supply of apparatus and material which would enable those in charge of a school laboratory to fill a balloon, and that schools thus equipped would be willing to co-operate in an inquiry into the structure of the upper air on some occasions which might be notified by broadcasting. Mr. L. F. Richardson has kindly given the Committee assistance in the matter and devised an effective means of supplying apparatus for filling balloons at the cost of two shillings each for the apparatus and a shilling for each turn. A note by Mr. Richardson is appended to this report. The Committee is of opinion that a co-operative investigation of that kind would afford evidence of the structure of the atmosphere in 'dirty weather,' which is much needed in order

to arrive at a reasoned conclusion with regard to the opposed views of the nature of a cyclonic depression.

The Committee accordingly asks for reappointment with the addition of the name of Mr. L. F. Richardson, F.R.S., and for permission to retain the grant of £70 made last year to defray the expenses of a co-operative investigation.

Problem : To find the cheapest way of filling 'Post Card Balloons' simultaneously. One at each of 100 places scattered over the British Isles.

Purity of hydrogen and accuracy of adjustment of lift have been regarded as of secondary importance. The following process has been found to work well.

Apparatus.—Balloon weighing 5.5 grams empty. Tinned-iron can of capacity 580 cm.³ with air-tight lid through which is soldered a brass pipe of external diameter 0.9 cm., so as to project 6 cm. outside the can and 1 cm. inside. Carton cup holding 140 cm.³ (sold for holding preserved cream). Calcium hydride of Messrs. J. J. Griffin's (Kemble St., Kingsway, London, W.C. 2) cheaper quality, 1s. per oz. Bucket of cold water. Teapot or small jug with spout. Post card. Thin cotton string. Balance weighing to 0.1 gram.

Working Instructions.—Slip the neck of the balloon 1 cm. on to the brass pipe and tie in place. Weigh out 12.5 grams of hydride in lumps, rejecting powder, as it so rapidly spoils in damp air. Dry the canister internally and put the hydride into it. Lower the carton cup into place and fill it with water from the jug, taking care not to spill any water on hydride. Press the lid into place. Now slightly tilt the canister so as to spill a little water on the hydride. To prevent a high temperature float the canister in water in the bucket. If the balloon fills lop-sidedly it may often be made symmetrical by squeezing the bloated side. Continue the tilting and shaking until all the water is spilt and no more fizzling can be heard in the canister. The balloon should then be about 30 cm. in diameter, and is ready to be tied at the neck after the manner of a football bladder.

Suggestions for Organisations.

The vendors of the calcium hydride might be persuaded to supply it ready weighed in sealed glass tubes, each containing just enough for one balloon. The canisters and cartons should be got ready by a firm and distributed by the firm to the observers.

Estimate of Cost in Pence.

	1st Ascent.	d.	Subsequent Ascents.
Post card		1½	} 10½d. each.
Balloon		3	
Hydride		6	
Canister		4	
Supplying and soldering pipe		6 ?	
Carton		2 ?	
Carriage		12 ?	
	Total	<u>34½ ?</u>	

Other Methods, Rejected, and the Reasons for Rejecting them.

1. Aluminium and NaOH in the same apparatus. Dangerous, for caustic froth entered balloon, and might be thrown in the operator's eyes if balloon burst. Calcium hydride and water is much less frothy and less caustic.

2. Cycle lamp as generator. Difficult to get the necessary pressure because the water vessel leaked.

3. Purchase of hydrogen gas compressed in cylinders. Conversation at British Oxygen Co.'s office indicated, without commitment, that their smallest size of cylinder contains 10 cubic feet of hydrogen. They have about 50 of these and would lend them free for a fortnight. The hydrogen would cost about 12½d. per cylinder. The charge for carriage is probably more and is difficult to estimate. (Cylinders are class 3 on rail.) For instance, King's Cross to Newcastle-on-Tyne would be 2½ by goods each way. Carriage would be reduced by distributing from Glasgow, Wolverhampton and London, whichever was nearest.

Objections: Carriage; doubt as to whether enough cylinders; rent of cylinders if kept too long.

Photographs of Geological Interest.—*Twenty-third Report of Committee* (Profs. E. J. GARWOOD, *Chairman*, and S. H. REYNOLDS, *Secretary*; Mr. G. BINGLEY, Mr. C. V. CROOK, Mr. A. S. REID, Prof. W. W. WATTS, and Mr. R. WELCH).

In the present report 443 photographs are listed, bringing the number in the Committee's collection to 7623. In the previous report (Oxford 1926) 611 photographs from the Reader series were included. In the present list there are 218 photographs from the Reader series; these are mainly from the Home counties, but include extensive sets from the Lizard and Llangollen areas.

The following have kindly helped with the description of the Reader photographs included in the present list: Mr. G. Barrow, Mr. E. S. Cobbold, Prof. A. Morley Davies, Mr. E. H. Davison, Mr. H. Dewey, Miss M. S. Johnston, Mr. A. L. Leach, Mr. R. W. Pocock, Dr. L. J. Wills, Mr. W. Wright.

The 1926 report included a valuable series of 80 photographs illustrative of the geology of the Isle of Wight taken by Mr. J. F. Jackson, and presented by Miss C. Morey and her late brother, Mr. F. Morey. Miss Morey kindly gives a further series of twenty-two of Mr. Jackson's Isle of Wight photographs. Mr. Jackson further contributes sets from Dorset and Devon; his photographs have a special value from the fullness of detail of the accompanying descriptions.

Important sets of photographs have been received from the following new contributors: Mr. J. Challinor, Mr. G. Macdonald Davies, Mr. J. Ranson, Dr. W. G. Shannon, and Mr. H. W. Turner. Mr. Davies' photographs, which illustrate no less than fourteen counties, are a particularly well-chosen and well-printed series. Dr. Shannon sends a beautiful series of enlargements illustrative of the geology of Torquay. The Welsh series is much strengthened by Mr. Challinor's set from Cardigan and the late Mr. T. W. Reader's from Denbigh.

Among former contributors the Committee have to thank Mr. E. S. Cobbold, Mr. G. G. Lewis and Mr. J. W. Tutchter. Mr. Lewis' varied and well-chosen series includes examples from ten counties.

Mr. T. Sheppard sends two enlargements illustrating coast erosion at Withernsea, and Mr. Harold Preston one of Salcombe Cliff.

Certain photographs by Sir A. Strahan and Mr. A. S. Reid taken many years ago have been added to the collection.

The photographs published by the Committee as prints or lantern slides are obtainable from the Secretary at the following rates:—

				£	s.	d.
1st issue—	22	Bromide Prints, with letterpress, unmounted..	..	1	13	0
"	22	" " " " mounted on cards..	..	2	4	0
"	22	Lantern Slides " " " " " " " " " " " "	..	2	4	0
2nd issue—	25	Bromide Prints " " unmounted..	..	1	18	0
"	25	" " " " mounted on cards..	..	2	10	0
"	25	Lantern Slides " " " " " " " " " " " "	..	2	10	0
3rd issue—	23	Bromide Prints " " unmounted..	..	1	14	6
"	23	" " " " mounted on cards..	..	2	6	0
"	23	Lantern Slides " " " " " " " " " " " "	..	2	6	0

The Reader negatives being the property of the Committee, prints ($\frac{1}{4}$ -plate) may be obtained through the Secretary at 4d. each, lantern slides at 1s. It is hoped before the publication of the next report to publish a fourth series of geological photographs.

The Committee recommend that they be reappointed.

TWENTY-THIRD LIST OF GEOLOGICAL PHOTOGRAPHS.

FROM JUNE 1, 1926, TO JUNE 30, 1927.

List of the geological photographs received and registered by the Secretary of the Committee since the publication of the last report.

Contributors are asked to affix the registered numbers, as given below, to their negatives, for convenience of future reference. Their own numbers are added in

order to enable them to do so. Copies of photographs desired can, in most instances, be obtained from the photographer direct. The cost at which copies may be obtained depends on the size of the print and on local circumstances over which the Committee have no control.

The Committee do not assume the copyright of any photograph included in this list. Inquiries respecting photographs, and applications for permission to reproduce them, should be addressed to the photographers direct.

Copies of photographs should be sent, unmounted, to

Professor S. H. REYNOLDS,
The University, Bristol,

accompanied by descriptions written on a form prepared for the purpose, copies of which may be obtained from him.

The size of the photographs is indicated, as follows:—

L=Lantern size.	1/1=Whole plate.
1/4=Quarter-plate.	10/8=10 inches by 8.
1/2=Half-plate.	12/10=12 inches by 10, &c.
P.C.=post card.	E signifies Enlargement.

ACCESSIONS.

England.

BERKSHIRE.—*Photographed by the late T. W. READER and presented by F. W. READER.* 1/4.

- 7181** (A) Bracknell Brick Works . . Fossiliferous nodule from London Clay. 1911.
7182 (B) Bracknell Brick Works . . Fossiliferous nodule from London Clay. 1911.
7183 (C) Bracknell Brick Works . . Septarian nodules from London Clay. 1911.
7184 (D) Bracknell Brick Works . . Septarian nodules in London Clay. 1911.
7185 (E) Bracknell Brick Works . . Upper part of the London Clay. 1911.

BUCKINGHAMSHIRE.—*Photographed by G. M. DAVIES, M.Sc., 104 Avondale Road, South Croydon.* 1/4.

- 7186** (13-25) Warren Farm, Stewkley . Purbeck Marl on Portland Stone on Portland Sand. 1913.
7187 (13-26) Hedges' Brickfield, Stewkley . Kimmeridge Clay crumpled by ice-pressure. 1913.
7188 (26-43) Hartwell, 2 m. S.W. of Aylesbury . Large ammonites and concretions from Portlands built into wall. 1926.

Photographed by G. G. LEWIS, Ellerslie Road School, London, W. 12. 1/4.

- 7189** (4) Combe Hill, Wendover . . Chiltern escarpment, characteristic Chalk hill curve.

Photographed by the late T. W. READER and presented by F. W. READER. 1/4.

- 7190** (1) Cowcroft, near Chesham . Thrust plane at junction of Chalk and Reading beds. 1915.
7191 (2) Cowcroft, near Chesham . Thrust plane at junction of Chalk and Reading beds. 1915.
7192 (3) Cowcroft, near Chesham . Green-coated flint bed at thrust junction of Chalk and Reading beds.
7193 (4) Cowcroft, near Chesham . Reading pebble drift lying horizontally on inclined Reading beds. 1915.
7194 (5) Cowcroft, near Chesham . Faulted Reading sand overlain by Reading pebble drift. 1915.
7195 (6) Cowcroft, near Chesham . Drift on Reading beds showing erosion by torrential rain. 1915.

- 7196** (7) Cowcroft, near Chesham . . . Erosion hollows in Reading beds filled with pebble drift. 1915.
- 7197** (8) Cowcroft, near Chesham . . . Erosion effect on Reading Sands of a storm. 1915.
- 7198** (9) Cowcroft, near Chesham . . . Erosion effects on Reading Sands of a storm. 1915.
- 7199** Walter's Ash Blocks of Sarsen for repair of Windsor Castle. 1919.
- 7200** Walter's Ash Sarsen workings. 1919.
- 7201** Walter's Ash Sarsens in situ. 1919.
- 7202** Walter's Ash Sarsens in situ. 1919.
- 7203** Hartwell, 2 m. S.W. of Aylesbury . . . Large ammonites and concretions from Portlands built into wall.

Photographed by H. W. TURNER, M.A., The University, Bristol. P.C.

- 7204** (1.24.3) Calvert Brick Works, Method of working Oxford Clay pit. Charndon 1926.

CORNWALL.—*Photographed by G. M. DAVIES, M.Sc., 104 Avondale Road, South Croydon. 1/4.*

- 7205** (8.8) W. of St. Ives 'Greenstone' resisting wave action. 1908.
- 7206** (8.11) Land's End 'Castellated' weathering of granite due to vertical jointing. 1908.
- 7207** (12.25) Marble Cliff, Porthmissen, 2 m. W. of Padstow Alternating limestone and slate (Up. Devonian). 1912.

Photographed by E. H. DAVISON, B.Sc., School of Mines, Camborne. 3 × 2.

- 7208** Pendour Cove, Gurnard's Head, Penzance Granite veins cutting greenstone boulder. 1926.
- 7209** Cullis' Qu., Ponsanooth Vein of pegmatite in granite with selvage of aplite. 1926.
- 7210** Fistral Bay, Newquay Raised Beach with vertical cylindrical pipes.

Photographed by F. ENGLEHEART and presented by E. H. DAVISON, B.Sc., School of Mines, Camborne. P.C.

- 7211** Cullis' Qu., Ponsanooth Pegmatite vein with aplite margin.

Photographed by G. G. LEWIS, Ellerslie Road School, London, W. 12. 1/4.

- 7212** (17) Fistral Bay, near Newquay Raised beach.
- 7213** (20) Pentire Head Differential erosion of vertical Devonians.
- 7214** (21) Perranporth Stages in the production of stacks and inlets.
- 7215** (22) Bedruthan Steps, N. of Newquay Dependence of form of sea stacks on dip.
- 7216** (23) Holywell Sand dunes with marram grass.

Photographed by the late T. W. READER and presented by F. W. READER. 1/4.

- 7217** (90) Baulk Head, Lizard Manaccan Series (L. Devonian). 1913.
- 7218** (91, A) Baulk Head, Lizard Manaccan Series (L. Devonian). 1913.
- 7219** (87) Gunwalloe, Lizard Folded Manaccan beds. 1913.
- 7220** (98) Gunwalloe Contorted Veryan sandstone. 1913.
- 7221** Mullion Cliffs of hornblende schist. 1913.
- 7222** Kynance Formation of arches by marine erosion along joints in serpentine. 1913.
- 7223** Kynance Serpentine coast. 1913.

- 7224 Kynance Serpentine coast. 1913.
 7225 (69) Man of War rocks from Lizard lighthouse Rocks are formed of Man of War gneiss. 1913.
 7226 (69, A) Man of War rocks from Lizard lighthouse Rocks are formed of Man of War gneiss. 1913.
 7227 E. of Lizard Point Cliffs of hornblende gneiss. 1913.
 7228 E. of Lizard Point Cliffs of hornblende gneiss. 1913.
 7229 (75) Polpeor, Lizard Cove due to erosion along dyke. 1913.
 7230 (74) Polpeor, Lizard Contorted hornblende schist. 1913.
 7231 Housel Bay, Lizard Marine erosion of hornblende schists. 1913.
 7232 (67) Cadgwith, Lizard Quarry in hornblende schist. 1913.
 7233 (66a) Cadgwith, Lizard, the Devil's Frying Pan Hollow probably produced by collapse of roof of cave eroded mainly in serpentine. 1913.
 7234 (53) Kennack, Lizard Kennack gneiss intrusive in serpentine. 1913.
 7235 (54) Kennack, Lizard Plexus of Kennack gneiss veins. 1913.
 7236 (55) Kennack, Lizard Bastite serpentine. 1913.
 7237 (59) Kennack, Lizard Block of Kennack gneiss. 1913.
 7238 (62) Kennack, Lizard Brecciated steatitic serpentine. 1913.
 7239 (36a) Spernic Cove, Lizard Serpentine coast. 1913.
 7240 (33) Carrick Luz, Lizard Intrusive gabbro mass. 1913.
 7241 (35) Carrick Luz, Lizard Gabbro showing flow foliation. 1913.
 7242 (36) Carrick Luz, Lizard Gabbro showing flow foliation. 1913.
 7243 (28) Chynhall's Point, Coverack Serpentine coast. 1913.
 7244 (29) Chynhall's Point, Coverack The sea as an eroding agent. 1913.
 7245 (29a) Chynhall's Point, Coverack The sea as an eroding agent. 1913.
 7246 (30) Chynhall's Point, Coverack Fissure weathering of serpentine. 1913.
 7247 (31) Chynhall's Point, Coverack Prismatic weathering of serpentine. 1913.
 7248 (32) Chynhall's Point, Coverack Prismatic weathering of serpentine. 1913.
 7249 (32a) Chynhall's Point, Coverack Prismatic weathering of serpentine. 1913.
 7250 (14) Coverack Weathered serpentine. 1913.
 7251 (9) Coverack Gabbro pegmatite. 1913.
 7252 (13) Coverack Gabbro cutting bastite serpentine. 1913.
 7253 (15) Coverack Basic dykes cutting serpentine. 1913.
 7254 (15a) Coverack Basic dykes cutting serpentine. 1913.
 7255 (16) Coverack Weathered surface of bastite serpentine. 1913.
 7256 (19) Crousa Down, Coverack Residual blocks of gabbro. 1913.
 7257 (20) Crousa Down, Coverack Residual blocks of gabbro. 1913.
 7258 (21) Crousa Down, Coverack Pliocene gravel. 1913.
 7259 (21a) Crousa Down, Coverack Pliocene gravel. 1913.
 7260 (23) Crousa Down, Coverack Pliocene gravel. 1913.
 7261 (5) Lowland Point, near Coverack Broad terrace at foot of cliff is raised beach. 1913.
 7262 (41) Lowland Point, Coverack Raised beach platform from N. 1913.
 7263 (24) St. Keverne, Lizard Weathering of gabbro producing core-boulders or 'niggerheads.' 1913.
 7264 (44a) Nare Head Devonian shales with plant remains. 1913.
 7265 (38) S.W. of Nare Point Head resting on Devonian. 1913.
 7266 (45) Dennis Head, S. of Helford river Portscatho series (Ordovician). 1913.
 7267 (80) Kynance Brecciated steatitic serpentine. 1913.
 7268 (70) Lizard Pebble of steatitic serpentine. 1913.

Photographed by H. W. TURNER, M.A., The University, Bristol. 1/4.

- 7269 (1-9-3) Little Trevisco, near St. Stephens China pit showing sluicing process. 1922.
 7270 (1-18-3) Pen Voose, Lizard Kennack Gneiss. 1924.
 7271 (1-18-2) Chynhall's Point, near Coverack Gabbro dyke cutting serpentine. 1924.

CUMBERLAND.—*Photographed by G. M. DAVIES, M.Sc., 104 Avondale Road, South Croydon. 1/4.*

- 7272** (10·9) Roadside, N. of Rosthwaite, Borrowdale . . . Moraine resting on glaciated rock surface. 1910.

Photographed by B. SMITH, M.A., Sc.D., H.M. Geological Survey, 28 Jermyn Street, London, S.W. 1. 1/4.

- 7273** Corney Hall, near Bootle . . . Dry valley, a marginal glacial drainage channel. 1910.
- 7274** Kinmont dry valley, near Bootle . . . Drainage channel marginal to Irish Sea ice. 1910.
- 7275** Kinmont Beck valley, E. of Low Kinmont, near Bootle . . . Preglacial valley in Eskdale granite. 1910.
- 7276** Near Bank, near Bootle . . . Glacial 'in and out' valley. 1910.

DERBYSHIRE.—*Photographed by G. G. LEWIS, Ellerslie Road School, London, W. 12. 1/4.*

- 7277** (6) Doveholes, near Tissington . . . Wide-mouthed cave in Carboniferous Limestone. 1925.

Photographed by R. O., Chellaston, Derby, and presented by B. SMITH, M.A., Sc.D., H.M. Geological Survey, 28 Jermyn Street, London, S.W. 1. 1/2.

- 7278** Chellaston alabaster quarry . . . Pillar of gypsum.

DEVONSHIRE.—*Photographed by G. M. DAVIES, M.Sc., 104 Avondale Road, South Croydon. 1/4.*

- 7279** (24·10) Pinhay Bay, looking W. . . Lias section with White Lias at base. 1924.
- 7280** (22·1) Path to Samson's Cave, Combe Martin . . . Worm burrows ('fucoids') in Lester series. 1922.
- 7281** (22·19) Wild Pear Beach, Combe Martin . . . Overfolded Hangman grits. 1922.

Photographed by J. F. JACKSON, F.G.S., 2 St. Thomas's Square, Newport, I.W. 1/4.

- 7282** (1) Between Pinhay and Charton Bays, Seaton . . . Landslip. 1927.
- 7283** (2) Between Pinhay and Charton Bays, Seaton . . . Outflow of water from springs rising in the landslip. 1927.
- 7284** (3) Humble Point, Charton Bay, E. of Seaton . . . Surface of nodular Middle Chalk. 1927.
- 7285** (4) Humble Point, Charton Bay, E. of Seaton . . . Base of Middle Chalk with phosphate nodules on Cenomanian. 1927.
- 7286** (5) Humble Point, Charton Bay, Seaton . . . Planed off and bored surface of Upper Greensand. 1927.
- 7287** (6) Charton Bay, E. of Seaton . . . Up. Cretaceous unconformable on L. Lias and Rhaetic. 1927.

Photographed by H. PRESTON, Milton House, Sidmouth. 1/1.

- 7288** Salcombe Cliffs, Sidmouth . . . Erosion of red Trias Marl. 1926.

Photographed by W. G. SHANNON, D.Sc., Beverley Lodge, Torquay. 1/1.

- 7289** Meadfoot, Torquay . . . Shows position of Meadfoot and Daddy Hole—Thatcher thrust plane. 1922.

- 7290** Kilmore Hill, Torquay . . . Infolded Meadfoot grit and thrust plane. 1922.
- 7291** Shannell Cove, Torquay . . . Folding and inversion of Meadfoot beds. 1922.
- 7292** Black Head, Torquay . . . Dolerite on Up. Devonian thrust over schalstein. 1922.
- 7293** Hope's Nose, Torquay . . . Raised beach on folded Devonians. 1922.
- 7294** Hope's Nose, Torquay . . . Overfolding and thrusting of Devonian limestone. 1922.
- 7295** Anstey's Cove, Torquay . . . Relations of dolerite and Devonians. 1922.

Photographed by H. W. TURNER, M.A., The University, Bristol. 1/4.

- 7296** (1·1·2) Redgate beach, Torquay . Slickensided fault face, Mid-Devonian. 1921.
- 7297** (1·2·2) Hope's Nose, Torquay . Raised beach on Mid-Devonian Lst. 1921.
- 7298** (1·3·2) Saltern Cove, Paignton . Crush breccia in Devonian Lst. 1921.
- 7299** (1·4·1) Hunter's Tor, near Lustleigh . Weathering of granite. 1921.
- 7300** (1·4·2) Packsaddle Bridge, Lustleigh . Elvan dyke in Culm. 1921.
- 7301** (1·1·4) West Town, Ide, near Exeter . Interbedded Permian sandstone and lava. 1921.

DORSET.—*Photographed by G. M. DAVIES, M.Sc., 104 Avondale Road, South Croydon. 1/4.*

- 7302** (23·2) Tilly Whim, Swanage . Old workings in Portland Stone. 1923.
- 7303** (13·5) Arishmell, near Lulworth, looking E. . Incipient caves in highly inclined Up. Chalk. 1913.
- 7304** (23·8) Arishmell and Worberrow Bay . Marine erosion in soft Wealdens after breaching of Portland barrier.
- 7305** (23·10) Fossil Forest, Lulworth . Tufa masses round tree stumps in L. Purbeck. 1923.
- 7306** (13·1) Portland A stone quarry. 1913.
- 7307** (13·2) Portland, N.E. of light-house . Raised beach overlain by angular rubble. 1913.
- 7308** (12·8) Bridport, W. cliff . . . Fuller's Earth faulted against Bridport Sand. 1912.
- 7309** (12·5) Burton Bradstock . . . Lane section showing Bridport Sand passing up into Inferior Oolite. 1912.

Photographed by J. F. JACKSON, F.G.S., 2 St. Thomas's Square, Newport, I.W. 1/4.

- 7310** (7) Watton Cliff, Bridport . . . Forest Marble on Fuller's Earth. 1927.
- 7311** (8) Burton Bradstock cliff . . . Inferior Oolite sequence. 1927.
- 7312** (9) Burton Bradstock cliff . . . Inferior Oolite: 'Red Bed' with 'Snuff-box bed' at base. 1927.
- 7313** (10) Burton Bradstock cliff . . . Weathered surface of 'Snuff-box bed' (Inferior Oolite). 1927.
- 7314** (11) Burton Bradstock cliff. . . 'Snuff-box bed' (Inferior Oolite) in section. 1927.
- 7315** (12) Burton Bradstock cliff, W. end . Bridport Sands. 1927.
- 7316** (13) Cliffs W. of Watton Cliff, Bridport . Middle and Upper Lias. 1925.
- 7317** (14) The 'Western cliffs' from Watton Cliff, Bridport . Bathonian in foreground faulted against Lias of distant cliffs. 1927.
- 7318** (15) The 'Western cliffs' from Watton Cliff, Bridport . Succession Middle Lias to Bridport Sands. 1927.

- 7319** (16) Shore below Thorncombe Beacon, Bridport Lias cliffs, doggers on shore. 1927.
- 7320** (17) Thorncombe Beacon, Bridport Lias section showing 'Junction bed.' 1927.
- 7321** (18) E. end Thorncombe Beacon, Bridport Lias section with 'Junction bed.' 1925.
- 7322** (19) Thorncombe Beacon, Bridport 'Junction bed.' 1925.
- 7323** (20) Down Cliff, E. of Seatown . Bedding plane with *spinatum*-zone fossils. 1927.
- 7324** (21) Doghus Cliff, E. of Seatown, nr. Bridport Non-sequence in 'Junction-bed.' 1927.
- 7325** (22) Thorncombe Beacon, Bridport Non-sequence in 'Junction-bed.' 1925.
- 7326** (23) Thorncombe Beacon, Bridport Non-sequence in 'Junction-bed.' 1927.
- 7327** (24) Thorncombe Beacon, Bridport Non-sequence in 'Junction-bed.' 1927.
- 7328** (25) Watton Cliff, Eypemouth, nr. Bridport Position of 'Junction-bed.' 1925.
- 7329** (26) Watton Cliff, Eypemouth, nr. Bridport Cliff before excavation. 1925.
- 7330** (27) Watton Cliff, Eypemouth, nr. Bridport Cliff after excavation. 1925.
- 7331** (28) Watton Cliff, Eypemouth, nr. Bridport Bathonian faulted against Lias; fallen blocks of 'Junction-bed.' 1925.
- 7332** (29) Watton Cliff, Eypemouth, nr. Bridport 'Junction-bed' in situ. 1927.
- 7333** (30) Watton Cliff, Eypemouth, nr. Bridport Blocks of 'Junction-bed' on shore. 1927.
- 7334** (31) Watton Cliff, Eypemouth, nr. Bridport Full sequence of 'Junction-bed.' 1925.
- 7335** (32) Watton Cliff, Eypemouth, nr. Bridport 'Junction-bed' in situ. 1925.
- 7336** (33) Watton Cliff, Eypemouth, nr. Bridport 'Junction-bed' showing weathering of lithographic limestone. 1925.
- 7337** (34) Watton Cliff, Eypemouth, nr. Bridport 'Junction-bed' showing thinning out of layers. 1925.
- 7338** (35) Watton Cliff, Eypemouth, nr. Bridport 'Junction-bed' (Watton Bed) in situ. 1925.
- 7339** (36) Doghus Cliff, E. of Seatown . Dogger from Middle Lias. 1927.
- 7340** (37) Down Cliff, E. of Seatown . Doggers from Middle Lias. 1927.

Photographed by G. G. LEWIS, *Ellerslie Road School, London, W. 12.* 1/4.

- 7341** Portland Bill Undercutting by the sea.
- 7342** (15) Swanage Marine erosion along horizontal bedding plane.

Photographed by H. W. TURNER, M.A., *The University, Bristol.* P.C.

- 7343** (1-21-3) Bacon Hole, Lulworth and Mewp Rocks Top of Portland and Lower Purbeck in Mewp rocks, and Up. Purbeck in cliff. 1925.
- 7344** (1-6-3) Waddon, near Portisham . Chert in Portlands. 1922.
- 7345** (1-7-1) Sandsfoot Castle, Weymouth Blocks of fucoid bed, Sandsfoot grits. 1922.
- 7346** (1-5-3) Foreshore below White Nothe Block of Chloritic Marl with Holasters.

ESSEX.—Photographed by G. G. LEWIS, *Ellerslie Road School, London, W. 12.* 1/4.

- 7347** (19) Dovercourt Submerged Forest.
- 7348** (18) Dovercourt Submerged Forest.

GLoucestershire.—*Photographed by G. G. LEWIS, Eilerslie Road School, London, W. 12. 1/4.*

- 7349** (10) Bisley, near Stroud . . . Passage from solid rock, through subsoil to surface soil.
7350 (9) Robinswood Hill, Gloucester . . . Outlier of Lias capped by base of Oolite.
7351 (8) Cleeve Cloud, Cheltenham . . . Cotteswold escarpment.

Photographed by H. W. TURNER, M.A., The University, Bristol. 1/4.

- 7352** (1·20·3) Portway, Clifton, near foot of Gully Dolomite and shale (C_2). 1924.
7353 (1·20·2) Portway, Clifton (near New Zigzag) Concretionary lower surface (D_1). 1924.
7354 (1·11·2) Portway, between Sea Mills and Shirehampton Dolomitic Conglomerate unconformable on O.R.S. 1923.
7355 (1·5·2) Portway, about $\frac{3}{4}$ m. E. of Shirehampton station Hard sandstone band in Keuper Marl. 1921.

Photographed by J. W. TUTCHER, M.Sc., 57 Berkeley Road, Bishopston, Bristol. 1/1.

- 7356** Hanham Green, near Hanham Abbot *Angulata* and *Bucklandi* beds (L. Lias). 1902.

HAMPSHIRE (ISLE OF WIGHT).—*Photographed by J. F. JACKSON, F.G.S., 2 St. Thomas's Square, Newport, I.W., and presented by Miss C. MOREY. 1/4.*

- 7357** (193) S.W. face of Headon Hill . . . Succession Barton beds to Bembridge Limestone. 1926.
7358 (194) Headon Hill from Alum Bay Pier Barton Sands and Oligocene beds. 1926.
7359 (195) Alum Bay cliffs from the pier Vertical Bagshot and Bracklesham beds. 1926.
7360 (196) By pier, Alum Bay . . . Marine erosion. 1926.
7361 (197) By pier, Alum Bay . . . Marine erosion. 1926.
7362 (198) Alum Bay . . . 'Mud glacier.' 1926.
7363 (199) Mouth of Shepherd's Chine, Atherfield Chine formation in Wealden shales. 1926.
7364 (200) Cowleaze Chine, Atherfield . . . Coast erosion and stream diversion. 1926.
7365 (201) Near Cliff Terrace, Blackgang Wind and rain erosion of Ferruginous Sands. 1926.
7366 (202) Near Cliff Terrace, Blackgang Undercutting by wind-erosion of hard sandstone band. 1926.
7367 (203) Top of Atherfield, High Cliff Wind eroded platform and sand dunes. 1926.
7368 (204) Chale Bay from Atherfield Point Lower Greensand sequence. 1926.
7369 (205) Bouldnor Cliff, Hamstead . . . Upper Hamstead beds. 1926.
7370 (206) Bouldnor Cliff, Hamstead . . . Details, Upper Hamstead beds. 1926.
7371 (207) Bouldnor Cliff, Hamstead . . . Block from shell-band in Upper Hamstead. 1926.
7372 (208) Bouldnor Cliff, Hamstead . . . Part of the great 'mud-glacier.' 1926.
7373 (209) The Needles, from the sea . . . Sea-stacks in highly inclined *mucronata* Chalk. 1926.
7374 (210) Brook Bay and Hanover Point Cliffs of Wealden marls and site of 'Pine raft.' 1927.
7375 (211) Compton Bay . . . Rain channels in soft Ferruginous Sands. 1927.
7376 (212) Compton Bay . . . Sequence of strata Wealden to Lower Chalk. 1927.
7377 (213) Compton Bay . . . Junction Upper Greensand and Chloritic Marl. 1927.

- 7378** (214) Compton Bay Nodule bed at base of Chloritic Marl. 1927.
7379 (215) Between Brook Chine and Hazel-nut gravels on Wealden marls. 1927.
 Hanover Point

Photographed by the late T. W. READER, and presented by F. W. READER. 1/4.

- 7380** High Down and the Needles . Shows the dependence of the shape of the Needles on the dip.
7381 Alum Bay and High Down with Southward decrease in angle of dip.
 the Needles

Photographed by H. W. TURNER, M.A., The University, Bristol. 1/4.

- 7382** (1·10·4) Cowleaze Chine . . . Eroded in horizontally lying Wealden sandstone and shale. 1923.
7383 (1·10·2) Cowleaze Chine . . . Waterfall at head of Chine showing undercutting of sandstone band in Wealden shale. 1923.

HEREFORDSHIRE.—*Photographed by G. G. LEWIS, Ellerslie Road School, London, W. 12. 1/4.*

- 7384** (14) Malvern Hills from British Looking N. to Worcestershire Beacon.
 Camp

HERTFORDSHIRE.—*Photographed by the late T. W. READER, and presented by F. W. READER. 1/4.*

- 7385** (1) Ayot Pocket of glacial gravel driven into disturbed Eocene clay. 1910.
7386 (2) Ayot Reading sands bending down to occupy cavity in Chalk. 1910.
7387 (3) Ayot Reading sands. 1910.
7388 (4) Ayot Current bedded Reading sands. 1910.
7389 (6) Ayot Westleton shingle. 1910.
7390 (7) Letchworth Gravels piping into Chalk. 1910.
7391 (8) Letchworth Gravels capping Chalk. 1910.
7392 (9) Near Letchworth station . . . Glacial gravels. 1910.
7393 (10) Arlesey Section of Chalk Marl. 1910.
7394 (11) Arlesey Section of Chalk Marl. 1910.
7395 (12) Arlesey Totternhoe Stone with over and underlying strata. 1910.

KENT.—*Photographed by the late T. W. READER, and presented by F. W. READER. 1/4.*

- 7396** (1) Rock Pit, Elmstead . . . Blackheath beds. 1914.
7397 (2) Rock Pit, Elmstead . . . Blackheath beds. 1914.
7398 (3) Rock Pit, Elmstead . . . Blackheath beds. 1914.
7399 (4) Rock Pit, Elmstead . . . Blackheath beds. 1914.
7400 Norris' Pit, near Erith . . . Brickearth on Thanet Sands on Chalk. 1912.
7401 Norris' Pit, near Erith . . . Brickearth on Thanet Sands on Chalk. 1912.
7402 (1) Land's End, Sheppey . . . Cliff of London Clay. 1910.
7403 (2) Sheppey Erosion of London Clay cliff. 1910.
7404 (3) Sheppey Downwash from London Clay cliff. 1910.
7405 (4) Land's End, Sheppey . . . Septaria from London Clay. 1910.
7406 (5) Sheppey Sandy top beds of London Clay. 1910.
7407 (6) Leysdown, Sheppey . . . Shell-beach and low cliff of alluvium. 1910.

- 7408** (7) Leysdown, Sheppey . . . Outlying patches of alluvium surrounded by shell-beach. 1910.
- 7409** (8) Leysdown, Sheppey . . . Shell-beach. 1910.
- 7410** (9) Leysdown, Sheppey . . . Shell-beach (detail). 1910.
- 7411** (1) Peters' Quarries, Wouldham . . . Chalk—chiefly *R. cuvieri* and *H. subglobosus* beds.
- 7412** (2) Peters' Quarries, Wouldham . . . Chalk—chiefly *R. cuvieri* and *H. subglobosus* beds.
- 7413** (5) Peters' Quarries, Wouldham . . . Chalk—chiefly *R. cuvieri* and *H. subglobosus* beds.
- 7414** (6) Tingey's Pit, Wouldham . . . Middle Chalk—*T. lata* and *R. cuvieri* zones.
- 7415** (7) Borstal Manor Pit . . . Chalk—upper $\frac{2}{3}$ *M. cor-testudinarium* zone lower $\frac{1}{3}$ *H. planus* zone.
- 7416** (8) Margott's Pit, Burham . . . Chalk—mainly *H. subglobosus* beds.
- 7417** (9) Blue Bell Hill, Burham . . . Chalk—*R. cuvieri* and *H. subglobosus* beds.
- 7418** (10) Blue Bell Hill, Burham . . . Chalk—*S. varians* zone.
- 7419** (11) Blue Bell Hill, Burham, top pit . . . Chalk—mostly *H. planus* zone.
- 7420** (12 a.b.c.) Blue Bell Hill, Burham . . . Chalk—*H. planus* to *H. subglobosus* beds.
- 7421** (13) Burham . . . Chalk—top pit in *T. lata* and *R. cuvieri*, lower in *H. subglobosus* beds.
- 7422** (14) Burham . . . Chalk—top pit in *T. lata* and *R. cuvieri*, lower in *H. subglobosus* beds.
- 7423** (15) Burham . . . Chalk—old pit in *S. varians* beds.
- 7424** Peill's Pit, Bromley South . . . Blackheath pebble beds. 1914.
- 7425** Peill's Pit, Bromley South . . . Blackheath pebble beds. 1914.
- 7426** Peill's Pit, Bromley South . . . Blackheath pebble beds. 1914.
- 7427** Peill's Pit, Bromley South . . . London Clay. 1914.
- 7428** Peill's Pit, Bromley South . . . London Clay on Woolwich and Oldhaven beds. 1914.
- 7429** Charlton . . . Blackheath beds on Woolwich beds on Thanet Sands on Chalk. 1913.
- 7430** Charlton . . . Blackheath beds on Woolwich beds on Thanet Sands. 1913.
- 7431** Charlton . . . Blackheath beds on Woolwich beds on Thanet Sands. 1913.
- 7432** Charlton . . . Blackheath pebble bed on Woolwich beds on Thanet Sand on Chalk. 1913.
- 7433** Charlton . . . Thanet Sands. 1913.
- 7434** Howe Hill Pit, Greenhithe . . . High terrace gravel and loam. 1919.
- 7435** Howe Hill Pit, Greenhithe . . . High terrace gravel and loam. 1919.
- 7436** (1) Barnfield Pit, Swanscombe . . . Middle gravel overlying lower loam of the 100-ft. Thames terrace. 1913.
- 7437** (2) Barnfield Pit, Swanscombe . . . Chalk pit, overlying strata removed. 1913.
- 7438** (3) Barnfield Pit, Swanscombe . . . Gravels of the 100-ft. Thames terrace overlying Chalk. 1913.
- 7439** (4) Barnfield Pit, Swanscombe . . . Solution hollows in Chalk filled with Pleistocene deposits. 1913.
- 7440** (5) Barnfield Pit, Swanscombe . . . Warped Pleistocene deposits in solution hollows in Chalk. 1913.
- 7441** (6) Barnfield Pit, Swanscombe . . . Gravels of 100-ft. Thames terrace resting on Thanet Sand. 1913.
- 7442** (7) Baker's Hole, Southfleet . . . Coombe deposits. 1913.
- Photographed by E. R. MARTIN, 114 Southlands Road, Bromley. $4\frac{1}{2} \times 3\frac{1}{2}$.*
- 7443** Elmstead, near Chiselhurst . . . Blackheath beds. 1920.
- Photographed by A. S. REID, M.A., Greenburn, Balfron, Stirlingshire. 1/4.*
- 7444** (B.38) Elham Valley . . . Infilling of Lenham beds in Chalk.
- 7445** (B.42) Elham Valley . . . Infilling of Lenham beds in Chalk.

- 7446** (B.44) Elham Valley Infilling of Lenham beds in Chalk.
7447 (B.45) Elham Valley Infilling of Lenham beds in Chalk.

LANCASHIRE.—*Photographed by G. M. DAVIES, M.Sc., 104 Avondale Road, South Croydon. 1/4.*

- 7448** (26-16) Quarry 1 m. S. of Huncoat Station Accrington mudstone (Coal Measures). 1926.
7449 (26-15) Worsaw Knoll, 2 m. N.E. of Clitheroe Knoll in Salt Hill Series (S.). 1926.
7450 (26-14) Black Hill, near Whalley Current bedding in L. Coal Measures. 1926.
7451 (26-13) Harper Clough Qu., near Rishton Bedding plane in 3rd grit with *Stigmaria* impressions. 1926.

Photographed by J. RANSON, 174 Willows Lane, Accrington.

- 7452** (1) Worsaw Knoll, 2 m. N.E. of Clitheroe Knoll in Salt Hill Series (S.).
7453 (2) Whalley banks, near Whalley Millstones in Lower Millstone Grit.
7454 (3) Whalley banks, near Whalley Millstones in Lower Millstone Grit.
7455 (4) Close Brow Qu., Rishton, near Blackburn Terminal curvature in Millstone Grit attributed to N.W. ice-sheet.
7456 (5) Wiswell Qu., near Whalley Terminal curvature in Millstone Grit accentuated by 'creep.'
7457 (6) River Calder, near Whalley Block of glacial conglomerate.
7458 (7) Close Brow Qu., Rishton, near Blackburn Haslingden flags.
7459 (8) Close Brow Qu., Rishton, near Blackburn Ripple-marked Haslingden flags.
7460 (9) Close Brow Qu., Rishton, near Blackburn Pitting probably due to worm-borings in Haslingden flags.

MIDDLESEX.—*Photographed by G. M. DAVIES, M.Sc., 104 Avondale Road, South Croydon. 1/4.*

- 7461** (9-1) Harefield, The Great Pit London Clay on Reading beds on Chalk (*M. cor-anguinum* zone). 1909.
7462 (9-2) Harefield, The Great Pit Reading beds on bored surface of Chalk. 1909.

Photographed by the late T. W. READER, and presented by F. W. READER. 1/4.

- 7463** (1) Harefield Flints rounded by 24 hours' grinding in mill. 1913.
7464 (2) Harefield London Clay on Upper Reading mottled clay. 1913.
7465 (3) Harefield Reading beds on Chalk. 1913.
7466 (4) Harefield Current bedded sands at base of Reading beds overlain by Reading Clay. 1913.
7467 (5) Harefield Current bedded sands at base of Reading beds. 1913.
7468 (6) Harefield London Clay. 1913.
7469 (7) Harefield Woolwich and Reading beds. 1913.

NORFOLK.—*Photographed by G. M. DAVIES, M.Sc., 104 Avondale Road, South Croydon. 1/4.*

- 7470** (19-27) Beeston Cliff, E. of Sheringham Cliff chiefly of Contorted drift, Weybourn Crag at base. 1919.
7471 (26-28) Hunstanton, the cliff General view of White Chalk, Red Chalk, and Carstone. 1926.
7472 (26-29) Foreshore, Hunstanton Erosion of Carstone along joints. 1926.

270 REPORTS ON THE STATE OF SCIENCE, ETC.

- 7473** (26-32) Hunstanton, the cliff . . . White Chalk on Red Chalk on Carstone. 1926.
7474 (26-36) Hunstanton, N.E. end of cliff White Chalk on Red Chalk on Carstone. 1926.
7475 (26-33) Ringstead Downs, 1-2 m. S.E. of Hunstanton Glacial overflow-channel in the Chalk. 1926.

Photographed by Sir A. STRAHAN, Fairfield, Goring, Reading. 1/4.

- 7476** Sheringham . . . Cliffs of Contorted Drift.
7477 Trimmingham . . . Chalk mass in Contorted Drift.
7478 Trimmingham . . . Chalk mass in Contorted Drift.

NORTHUMBERLAND.—*Photographed by G. M. DAVIES, M.Sc., 104 Avondale Road, South Croydon. 1/4.*

- 7479** (24-22) Beadnell Point . . . Pot-holed bedding plane of Bernician Limestone. 1924.

SHROPSHIRE.—*Photographed by E. S. COBBOLD, All Stretton, Church Stretton. 1/4 and 1/2.*

- 7480** Caer Caradoc, E. side looking S.W. Rhyolite crag. 1/4.
7481 Caer Caradoc, E. side looking N.E. Rhyolite crag; the Wrekin in the distance. 1/4.
7482 Caer Caradoc . . . Brecciated rhyolite or rhyolite tuff. 1905. 1/2.
7483 Caractacus' Cave, Caer Caradoc . Cave eroded along flow-planes of amygdaloidal rhyolite. 1905. 1/2.

Photographed by the late T. W. READER, and presented by F. W. READER. 1/4.

- 7484** (B) Harley Hill, near Much Wenlock Wenlock Limestone, well-bedded, with clay partings.
7485 (C) Harley Hill, near Much Wenlock Wenlock Limestone.
7486 (D) Blakeway Hollow Lane Qu., near Much Wenlock Jointing in Wenlock Limestone.
7487 (E) Blakeway Hollow Lane Qu., near Much Wenlock Weathering of well-bedded Wenlock Limestone.
7488 (F) Blakeway Hollow Lane Qu., near Much Wenlock Weathering of well-bedded Wenlock Limestone.
7489 (G) Blakeway Hollow Lane Qu., near Much Wenlock Weathering of well-bedded Wenlock Limestone.

SOMERSET.—*Photographed by the late T. W. READER, and presented by F. W. READER. 1/4.*

- 7490** Woolston, near Williton . . . Upper sandstone on Bunter conglomerate. 1914.
7491 Woolston, near Williton . . . Trias section—Upper sandstone on conglomerate. 1914.
7492 Woolston, near Williton . . . Upper sandstone on Bunter conglomerate. 1914.
7493 Woolston, near Williton . . . Bunter conglomerate. 1914.
7494 Woolston, near Williton . . . Bunter conglomerate breaking away along joint-planes. 1914.

SUFFOLK.—*Photographed by G. M. DAVIES, M.Sc., 104 Avondale Road, South Croydon. 1/4.*

- 7495** (13-18) Sudbury, pit near the cemetery Glacial sand, on Crag, on Thanet Sand, on Upper Chalk. 1913.
7496 (13-17) Sudbury, sand pit at Alexandra Brick Works Red Crag covered by Glacial gravel. 1913.

SURREY.—*Photographed by G. M. DAVIES, M.Sc., 104 Avondale Road, South Croydon. 1/4.*

- 7497** (13-13) Tyler's Green, Godstone . Pit in Folkestone Sand. 1913.
7498 (13-23) Limsfield Chart . . Cherty Hythe beds. 1913.
7499 (13-31) Welch's Pit, Claygate . Folded sand and clay (Claygate beds). 1913.
7500 (15-1) Copyhold Farm, E. of Red-hill Aptian-Fullers' Earth overlain by sand and sandstone. 1915.
7501 (15-29) Kennel Wood, Shirley, near Croydon Blackheath beds, current bedded sands and pebbles. 1915.
7502 (15-31) Kennel Wood, Shirley, near Croydon Blackheath beds, sands and pebbles. 1915.

Photographed by G. G. LEWIS, Ellerslie Road School, London, W. 12. 1/4.

- 7503** (12) Box Hill from Ranmoor Chalk escarpment. Common

Photographed by the late T. W. READER, and presented by F. W. READER. 1/4.

- 7504** Chilworth Roadside section of Folkestone Sands. 1911.
7505 Chilworth Roadside section of Folkestone Sands. 1911.
7506 Chilworth Ironstone veins in Folkestone Sands. 1911.
7507 Hayes Common Blackheath pebble beds. 1916.
7508 Hayes Common Blackheath pebble beds. 1916.
7509 Near Hayes Station Gravel pit filled from bourne which appeared after interval of 33 years. 1916.
7510 (1) Albury, near Shere Current bedded Folkestone Sand. 1916.
7511 (2) Albury, near Shere Current bedded Folkestone Sand. 1916.
7512 (3) Newlands Corner, near Shere . Clay-with-flints. 1916.
7513 (4) Newlands Corner, near Shere . Clay-with-flints. 1916.
7514 (5) Newlands Corner, near Shere . Clay-with-flints. 1916.
7515 (7) Newlands Corner, near Shere . Clay-with-flints. 1916.
7516 (6) Albury, near Shere Chalky Drift with pipes. 1916.
7517 (a) N. of Chobham Place, Chobham Common Up. Bagshot Sands, capped by Plateau gravel. 1916.
7518 (b) Rifle Range, Portnall Park, Chobham L. Bagshot Sands. 1916.
7519 (1) Brook Street Pit, Hindhead . Passage loams between Ferruginous Sands and Atherfield Clay. 1914.
7520 (2) Hindhead L. Greensand escarpment. 1914.
7521 (3) Hindhead View over the Weald. 1914.
7522 (4) Devil's Punch Bowl, Hindhead Hollow perhaps due to cutting back by a powerful spring. 1914.
7523 (5) Hindhead Atherfield Clay. 1914.
7524 (6) Brook Street Pit, Hindhead . Lower Ferruginous Sand, on passage loam, on Atherfield Clay. 1914.
7525 (1) Fairmile Park, Oxshott . . Ironstone concretion in Bracklesham beds. 1912.
7526 (2) Fairmile Park, Oxshott . . Bracklesham beds. 1912.
7527 (3) Fairmile Park, Oxshott . . Bracklesham beds. 1912.
7528 (4) Fairmile Park, Oxshott . . Lower Bracklesham beds. 1912.
7529 (5) Claygate Claygate beds on London Clay. 1912.
7530 (6) Claygate Folds due to slipping of beds down dip slope of syncline. 1912.
7531 (7) Claygate Folds in Claygate beds. 1912.
7532 (8) Claygate, Sim's Brickyard Bagshot Sands on Claygate beds. 1912.
7533 (9) Claygate, Sim's Brickyard . Claygate beds on London Clay. 1912.
7534 (1) Beddington Brick Works . Thanet Sand. 1913.
7535 (2) Beddington Brick Works . Thanet Sand. 1913.

- 7536 (3) Beddington Brick Works . Thanet Sand. 1913.
 7537 (4) Beddington Brick Works . Thanet Sand. 1913.
 7538 (1) Gomshall Folkestone beds, ironstained and with thin ironstone bands.
 7539 (2) Gomshall Current bedded Folkestone beds.
 7540 (3) Gomshall Current bedded Folkstone beds.
 7541 (4) Gomshall Concretion of ferruginous sand in Folkstone beds.
 7542 (5) Gomshall Concretion of ferruginous sand in Folkstone beds.
 7543 (6) Gomshall Chalk escarpment of N. Downs.

WORCESTERSHIRE.—*Photographed by G. G. LEWIS, Ellerslie Road School, London, W. 12. 1/4.*

- 7544 (13) E. end of Malvern Tunnel . Faulted Keuper marl. 1925.

YORKSHIRE.—*Photographed by C. M. BRADLEY. 1/4.*

- 7545 Penyghent From Crag Hill, Horton.

Photographed by G. M. DAVIES, M.Sc., 104 Avondale Road, South Croydon. 1/4.

- 7546 (26·11) Penyghent from above Scarps due to grit bands. 1926.
 Horton-in-Ribblesdale
 7547 (26·19) Near Cracoe Reef-knolls. 1926.
 7548 (26·18) Near top of Skelterton *Diphyphyllum* in situ. 1926.
 Knoll, Cracoe

Photographed by G. G. LEWIS, Ellerslie Road School, London, W. 12. 1/4.

- 7549 (16) N. of Filey Capes and bays.
 7550 (3) Filey Brig Differential marine erosion.

Photographed by J. RANSON, 174 Willows Lane, Accrington.

- 7551 (1) Crummaek Dale Syncline in Austwick grits, S. limb.
 7552 (2) Crummaek Dale Syncline in Austwick grits, N. limb.
 7553 (3) Norber, near Clapham . . . Carboniferous Limestone erratic.
 7554 (4) Norber, near Clapham . . . Basement conglomerate of Carboniferous.
 7555 (5) Malham Cove Rock-fall of winter of 1925. 1926.
 7556 (6) Malham Cove Rock-fall of winter of 1925. 1926.
 7557 (7) Malham Cove Rock-fall of winter of 1925. 1926.
 7558 (8) Moughton Scar Grikes in Carboniferous Limestone (D₁).
 7559 (9) Foxley Bank, 3 m. N. of Clitheroe Contorted Carboniferous Limestone.

Photographed by E. STRAKER, 'Eastern Morning News,' Hull, under the direction of T. SHEPPARD, M.Sc. 1/1.

- 7560 Waxholme, near Withernsea . Effect of coast erosion. 1926.
 7561 Waxholme, near Withernsea . Effect of coast erosion, nearer view. 1926.

Wales.

BRECON.—*Photographed by G. G. LEWIS, Ellerslie Road School, London, W. 12. 1/4.*

- 7562 (5) Clydach Valley, Brynmawr . Stream cutting back gorge.
 7563 (7) Under Blorenge, S. of Abergavenny Mud bog in Cwm.

CARDIGAN.—*Photographed by J. CHALLINOR, University College, Aberystwyth. 1/2 E.*

- 7564 (1) Clarach Bay, Aberystwyth, looking S. Drift on folded Aberystwyth grits. 1921.

- 7565** (2) Cormorant Rock, Aberystwyth Shore platform and sea stack of Aberystwyth grits. 1926.
- 7566** (3) Nant-y-golomen ddu Rheidol valley A hanging fall. 1922.
- 7567** (4) Rheidol gorge, $\frac{1}{2}$ m. S. of Pont Erwyd Pot-holes. 1922.
- 7568** (5) $1\frac{1}{2}$ m. N. of Borth . . . Storm beach. 1922.
- 7569** (6) 1 m. N. of Borth . . . Submerged forest. 1923.
- 7570** (7) Sarn Cymfelyn, Wallog . . . Pebble beach of doubtful origin running out to sea. 1922.
- 7571** (8) N. of Clarach Bay, Aberystwyth Sharp folding giving effect of unconformity. 1924.
- 7572** (9) S. of Clarach Bay, Aberystwyth Denudation along a 'smash plane.' 1926.
- 7573** (10) S. of Clarach Bay, Aberystwyth Coincidence of cliff face with bedding plane. 1922.
- 7574** (11) S. of Clarach Bay, Aberystwyth Shore platform with curved strike, dip faults and miniature escarpments. 1922.
- 7575** (12) S. of Clarach Bay, Aberystwyth Marine pot-hole formed at base of cliff by wave action. 1925.
- 7576** (13) Shore about $\frac{1}{2}$ m. N. of Aberystwyth Fault plane and marine erosion along it. 1925.
- 7577** (14) S. of Clarach Bay, Aberystwyth Erosion of cliff along bedding plane. 1922.
- 7578** (15) Shore $\frac{1}{2}$ m. N. of Aberystwyth Pitching anticline. 1925.
- 7579** (16) Shore $\frac{1}{2}$ m. N. of Aberystwyth Pitching anticline. 1925.
- 7580** (17) Shore $\frac{1}{2}$ m. N. of Aberystwyth Pitching anticline. 1925.
- 7581** (18) Shore N. of Aberystwyth . . . Reversed fault and cave formed along it. 1925.
- 7582** (19) Shore about $2\frac{1}{2}$ m. S. of Aberystwyth Cubical blocks resulting from erosion along bedding and joint planes. 1922.
- 7583** (20) Shore about 2 m. S. of Aberystwyth Contorted strata in plan. 1923.
- 7584** (21) Shore about 4 m. S. of Aberystwyth Erosion of boulder clay cliffs. 1926.
- 7585** (22) Shore about 4 m. S. of Aberystwyth Erosion of cliffs of boulder clay showing banding. 1926.
- 7586** (23) N. of Aberarth . . . Boulder clay pillars. 1926.
- 7587** (24) About $\frac{1}{2}$ m. E. of Careg Lydan Stacks and cliffs showing bedding and jointing. 1926.

CARNARVON.—*Photographed by G. M. DAVIES, M.Sc., 104 Avondale Road, South Croydon.* 1/4.

- 7588** (20-10) Porthdinllaen, near Morfa Nevin Precambrian spilite. 1920.
- 7589** (16-5) Porthdinllaen, near Morfa Nevin Precambrian spilite. 1916.
- 7590** (16-7) Porth Wen, near Morfa Nevin Cylindrical concretions of sandy-ironstone in Pleistocene-sand. 1916.

DENBIGH.—*Photographed by the late T. W. READER, and presented by F. W. READER.* 1/4.

- 7591** (8 and 9) Vale of Llangollen. . . Drift-covered Vale and Carb. Limestone fault-scarp. 1919.
- 7592** (10) Castell Dinas Brân (left) and Eglwyseg rocks (right), Llangollen The Aqueduct fault passes between the two hills. 1919.
- 7593** (14) Dee Valley from Castell Dinas Brân, near Llangollen Present and earlier course of the Dee. 1919.
- 7594** (15) Eglwyseg Rocks, Llangollen . Silurian country in foreground, Carb. Limestone fault-scarp on right. 1919.
- 7595** (16) Eglwyseg Rocks, Llangollen. Fault-scarp of Carb. Limestone. 1919.
- 7596** (18) Garth Trevor, near Llangollen Grit of Cefn-y-fedw sandstone series worked for Gannister. 1919.

- 7597** (19) Garth Trevor, near Llangollen Massive grit near top of sandy lst. series (Carb. Lst.).
- 7598** (20) Trevor Rocks, Garth, Llangollen Carb. Lst.; false-bedded sandy oolite underlying massive bed. 1919.
- 7599** (21) Trevor Rocks, Garth, Llangollen Carb. Lst.; false-bedded sandy oolite underlying massive bed. 1919.
- 7600** (22) Trevor Rocks, Garth, Llangollen Qu. in sandy limestone of Carb. Lst. series. 1919.
- 7601** (24) Australia Pit, Trevor . . . Lowest Coal Measures quarried for fire-clay and Gannister. 1919.
- 7602** (25) Australia Pit, Trevor . . . Lowest Coal Measures quarried for fire-clay and Gannister. 1919.
- 7603** (26) Australia Pit, Trevor . . . Aqueduct Grit, Cefn-y-fedw sandstone. 1919.
- 7604** (27) Near Whitehurst Halt and Pen-y-Bont Dee Valley where river enters post-glacial gorge. 1919.
- 7605** (28) Pen-y-Bont, terra-cotta brick works Etruria or Ruabon marls (Up. Coal Measures) capped on left by Glacial Drift. 1919.
- 7606** (31) Horseshoe Pass, Llangollen . Old workings in Pentre-dwfr slates on right. 1919.
- 7607** (33) Horseshoe Pass, Llangollen . Quarries in Pentre-dwfr slates in foreground. 1919.
- 7608** (34) Horseshoe Pass, Llangollen . Carb. Lst. escarpment in distance, Silurian hills midway. 1919.
- 7609** (36) Llangollen, Clogau Slate Qu., near Pentre-dwfr. Highly cleaved and inclined L. Ludlow slates. 1919.
- 7610** (37) Llangollen, Clogau Slate Qu., near Pentre-dwfr. Highly cleaved and inclined L. Ludlow slates. 1919.
- 7611** (38) Llangollen, Clogau Slate Qu., near Pentre-dwfr. Highly inclined and cleaved L. Ludlow slates. 1919.
- 7612** (39) Llangollen, Clogau Slate Qu., near Pentre-dwfr. Bedding and jointing in slates. 1919.
- 7613** (40) Llangollen, Clogau Slate Qu., near Pentre-dwfr. Slates breaking up along bedding planes under influence of weathering. 1919.
- 7614** (46) Pandy, near Glyn Ceiriog . Cleaved coarse Pandy ash (Caradocian). 1919.
- 7615** (47) Glyn Ceiriog . . . Old Qu. in Pen-y-glog slates (base of Wenlock). 1919.
- 7616** (49) Near Berwyn station . . . Highly inclined L. Ludlow beds. 1919.
- 7617** (44) Near Cefn Uchaf, Glyn Ceiriog Qu. in L. Ludlow shale. 1919.

MERIONETH.—*Photographed by G. M. DAVIES, M.Sc., 104 Avondale Road, South Croydon. 1/4.*

- 7618** (15-16) Aberdovey, looking W. down the Dyfi estuary The 'Roman Road.' 1915.
- 7619** (15-15) Aberdovey, looking E. up the Dyfi estuary The 'Roman Road.' 1915.

Photographed by G. G. LEWIS, Ellerslie Road School, London, W. 12. 1/4.

- 7620** (11) Mawddach Estuary . . . Bar or spit across river mouth.

Channel Isles.

ALDERNEY.—*Photographed by the late T. W. READER, and presented by F. W. READER. 1/4.*

- 7621** The Casquets, W. of Alderney . These rocks are composed of grits. 1921.
- 7622** The Casquets, W. of Alderney . These rocks are composed of grits. 1921.

GUERNSEY.—*Photographed by H. W. TURNER, M.A., The University, Bristol. P.C.*

- 7623** (1-8-4) Grand Camp (N. shore of island) Acid veins in diorite. 1922.

Palæozoic Rocks.—*Report of Committee* (Prof. W. W. WATTS, *Chairman*; Prof. W. G. FEARNSIDES, *Secretary*; Mr. W. S. BISAT, Prof. W. S. BOULTON, Mr. E. S. COBBOLD, Mr. E. E. L. DIXON, Dr. GERTRUDE ELLES, Prof. E. J. GARWOOD, Prof. H. L. HAWKINS, Prof. V. C. ILLING, Prof. O. T. JONES, Prof. J. E. MARR, Dr. T. F. SIBLY, Dr. W. K. SPENCER, Dr. A. E. TRUEMAN) *appointed to excavate Critical Sections in the Palæozoic Rocks of England and Wales.*

DURING the year 1926-7, the work of this Committee has been carried forward in three districts—Leintwardine, Herefordshire; Ravenstonedale, Westmorland; and the Church Stretton area, Shropshire.

At Leintwardine during the winter, Prof. Hawkins cleared and excavated, inch by inch, a column of strata three feet square and twelve feet deep at the classic 'Starfish Bed Quarry' on Church Hill. The first results of this work have been presented in a paper by Prof. Hawkins, to be published by the Geological Society of London. The owner of the property (Mr. C. Boughton Knight) has taken great interest in the research, and there are no charges to be defrayed by the Committee. Prof. Hawkins hopes to proceed further at a later date.

At Ravenstonedale, Prof. Garwood and other members of the Committee attempted, at Whitsuntide, 1927, to open up the section below the conglomerate exposed in Pinsky Gill. A trench was cut in the right bank of the stream west of the road bridge, and excavated until it became water-logged some three feet below water-level. Red and variegated shales of Carboniferous type were discovered in or under the conglomerate, but the main result was the proving of the conglomerate exposure as a buried cliff on the western side of a drift filled ravine which does not exactly coincide with the existing stream-course of Pinsky Gill. It is now clear that the exact stratigraphical relationships of the red conglomerate with its rhyolite and other igneous rock pebbles, to the *Spirifer*-bearing dolomites and shales and the Silurian slates below, cannot, at Pinsky Gill, be proved except by boring. The expenses incurred in making the excavation have been mainly defrayed by members attending Prof. Garwood's Whitsuntide excursion.

Mr. E. S. Cobbold writes as follows on his excavations among the Cambrian and associated strata in the Cwms Hollow, east of Caradoc, Church Stretton, his seventh report on his series of excavations:—

Seventh Report on Excavations among the Cambrian Rocks of Comley, Shropshire.

By E. S. COBBOLD, F.G.S.

On p. 118 of the Report of the Committee to the Manchester Meeting (1915) a short note is given of a few small trial holes in 'the Lower Ridge of the Cwms.' At the reading of a paper by the present writer on the stratigraphy of the Comley Cambrian, it seemed desirable that the junction of the Cambrian quartzite with the pre-Cambrian should be exposed if the permission of the present owner of the land, Mr. W. Jarrett, of the Cwms Farm, could be obtained. This he gave very willingly, and the writer wishes to acknowledge with cordial thanks his indebtedness to Mr. Jarrett.

Excavation No. 56. The Lower Ridge in the Cwms.

It will be seen by the section (page 276) that a trench, some 63 feet in length and 6 feet in maximum depth, was made transverse to the strike of the quartzite. It exposed 14 feet of incoherent red sandstone (Torridonian), 25 feet of beds assigned to the Wrekin quartzite and 24 feet of the base of the Lower Comley sandstones.

The strike of the Lower Cambrian beds is 20° west of north, that of the Torridonian, which had to be obtained in a subsidiary excavation, was found to be 20° north of east, and the two formations are separated by a 6-inch layer or vein of yellowish clay that appears to mark a fault hading at a steep angle northwards.

Description of the Section.

	Length of trench occupied.
<i>h.</i> Rubbly beds of greenish grey sandstone, with clayey partings and occasional narrow quartzitic bands	13 feet
<i>g.</i> Glauconitic, coarse-grained quartzite, with a few red grains of felsitic material and becoming at the base almost a rotten-stone	4 feet
<i>f.</i> Sandstones and shaly beds, with one narrow band of quartzite	7 feet
<i>e.</i> Compact, grey quartzite	8 feet
<i>d.</i> Compact, dark grey quartzite, in several beds	10 feet
<i>c.</i> Blocks of the same bed but broken into angular fragments, and with a few referable to higher beds	7 feet
<i>b.</i> A layer or vein of yellow clay (the fault)	—
<i>a.</i> Red, incoherent sandstone	14 feet

Remarks :—The gradual change from quartzite to sandstone is paralleled in excavations 4¹ and 53.²

The bed *g* has almost exactly the characters of bed *b2* of the latter and portions of *a*₂ of the former.

SECTION OF TRENCH IN THE CWMS, COMLEY.

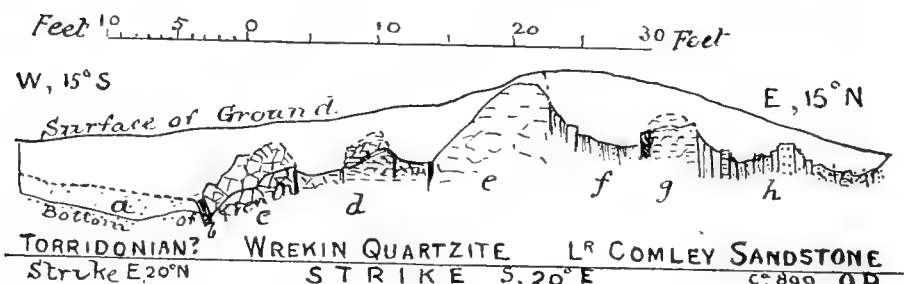

The red incoherent sandstone is strictly comparable with some of the beds of the Torridonian(?) seen in the brook 300 yards W.S.W. of the excavation, and the strike is the same at the two exposures. It seems obvious that though the Cambrian in this section is faulted against the Torridonian(?), the two formations are unconformable one to another, but the absolute base of the Cambrian has not yet been found.

Dolgarrog Dam Disaster.—*Report of Committee* (Dr. E. GREENLY, *Chairman*; Mr. E. MONTAG, *Secretary*; Prof. P. G. H. BOSWELL, Mr. I. S. DOUBLE, Prof. W. G. FEARNSIDES) *appointed to obtain Photographic Records of the Geological Effects of the 'Débâcle' which resulted from the recent bursting of a dam at Dolgarrog, North Wales.*

THE Dolgarrog disaster, as a result of which part of the small village of Porth-llŵyd was destroyed, occurred during the evening of November 2, 1925. Situated on the western side of the Conway Valley some 6½ miles south of Conway, the village lies at the mouth of the gorge of the Afon Porth-llŵyd, one of the small streams draining from the ridge of Carnedd Llewelyn, Foel Fras, and other mountains. The western side of the Conway Valley is hereabouts a steep rock-wall nearly 1,000 feet in height, and above it a mature drift-covered upland rises gently for three or four miles to the mountains, at the foot of which lies Llyn Eigiau at 1,219 feet above O.D. The existence of this lake is determined by a morainic bar which does not lie athwart the valley, but is aligned parallel to the ridge, *i.e.* north and south. The Afon Porth-llŵyd entered and also left the original lake near its southern end. The lake receives the greater part of its water from Cwm Eigiau, the principal eastern cwm of Carnedd

¹ *Rep. Brit. Assoc.* 1908, Dublin, p. 238 (1909); and 1915, Manchester, p. 121 (1916).

² *Idem* 1915, Manchester, p. 118 (1916).

Llewelyn, which lies to the south, but since the Clogwyn-r-Eryr ridge has been pierced by a tunnel, the surplus waters of the Afon Dulyn have been added from the north.

The River Course.

Though the area and level of Llyn Eigiau had, before the disaster, been materially altered by the erection of a dam on the morainic ridge, and the stream-course had been modified by subsidiary dams and leats, yet certain well-marked topographic stages can still be distinguished.

Stage I. *Llyn Eigiau to Pwll-du.*—After leaving the lake, the natural level of which is 1,219 feet above O.D., the Afon Porth-llŵyd meanders over a Drift-covered area for two miles down to the farm of Pwll-du, 1,150 feet above O.D. At this point rejuvenation of the stream begins, and a leat has been constructed to carry the water round a spur of Moel Eilio to Dolgarrog.

Stage II. *Pwll-du to the Low-level Dam.*—From Pwll-du the valley deepens and cliffs in Boulder Clay appear. Half a mile farther downstream, at 850 feet above O.D., the Low-level Dam, 40 feet in height, was constructed to hold up sufficient water for one day's supply for the pipe-line to Dolgarrog which begins here.

Stage III. *The Low-level Dam to the lip of the Rhaiadr Porth-llŵyd.*—For the next three-quarters of a mile of its course the river falls some 200 feet to the 650 feet contour. But above that, at a height of 750 feet above O.D., the solid rock appears in the river bed, and from this point the river flows through a rocky gorge with undercut cliffs of Boulder Clay resting on the rock-shelves.

Stage IV. *The Rhaiadr Porth-llŵyd.*—At the 650 feet level the gradient steepens so suddenly that this part of the stream-course may well be termed a lip. In less than a quarter of a mile the stream falls over bare rock from 650 feet above O.D. to a sloping ledge 350 feet above O.D. From where solid rock first appears (at 750 feet above O.D.) to this point, the stream-bed lies in what is apparently an auto-brecciated basic lava or intrusion. The sloping ledge is a pre-Boulder Clay topographic feature forming the southern bank of a pre-glacial valley which apparently deviates somewhat from the present stream-course and runs towards the north-east. This valley is filled with glacial debris and contains very large boulders. Intensive erosion here has resulted in the undercutting of a cliff of Boulder Drift 100 feet in width and 50 feet in height. This cliff now forms the northern wall of the present stream-course.

Stage V. *Below the Rhaiadr Porth-llŵyd to the Conway.*—From the ledge at 350 feet O.D. to the floor of the main valley, the stream passes through a post-glacial ravine cut in black pyritous shales into which an irregular mass of rhyolite-like rock has been intruded. The ravine has steeply cut sides and is noteworthy for the number of pot-holes both in its floor and at different levels on its flanks. The end of the gorge near to the Conway Valley is cut through black slates overlain by Boulder Clay. Thence the stream reaches the main river across an alluvial plain.

The Effects of the Flood.

Stage I.—A concrete wall, three-quarters of a mile in length, was constructed on the moraine (here overlain by peat) along the eastern side of Llyn Eigiau and the level of the lake was raised thereby from 1,219 feet to 1,239 feet above O.D. Special precautions were taken to strengthen the wall across the southern outlet of the lake, but a shallow saddle crossing the moraine about half a mile to the north of the outlet was not specially safeguarded. In the midst of this potential overflow channel slight seepage of water had apparently long been in progress, and when the heavy rains which preceded the disaster raised the level of Lake Eigiau the seepage increased inordinately. With augmented flow, the seepage developed to a well-defined spring which, bursting close to the wall, soon enlarged itself to a well, or cauldron, 30 feet in width and 20 feet in depth, over which the wall remained standing as a bridge. The spring in bursting lifted the peat bed which covers the Boulder Clay and broke it into rafts; these the waters floated forward or cast outwards to strand on the margins of the flood near by.

Around the cauldron of emergence neither peat nor Boulder Clay are in any way disturbed, and, notwithstanding that 120 million cubic feet of water flowed forth over the moor, there is for the next 100 yards no perceptible water-channel, neither grass nor heather being uprooted. A little way below the cart-track the hollow in the moorland becomes more evident, and the flood, when it found this, confined itself to

a deeper and narrower track. Here, under a very few feet of water, the peat-bed, 4 to 6 feet in thickness, seems to have floated up and, separating itself from the moraine in cakes and strips, often many tens of square yards in extent, allowed the rushing waters to uncover and erode the Boulder Clay. Across the 400 yards of moorland, as far as the main Afon Porth-llŷyd, a new stream-course 50 to 100 feet in width was thus defined. The course was deepened generally by some 6 to 10 feet, with one or more narrow channels locally incised within it to a depth of 20 feet. The finer debris from this new cut was carried forward with the flood, but stones more than six or eight inches in diameter were dropped as a delta at the edge of the main valley. Peat rafts were also moved a little way, but most of them were detached in masses so large and so well loaded with root-clay that the flood could not transport them to any great distance. Many rafts of intermediate size were left stranded in the shallows before the flood-waters reached the course of the main Afon Porth-llŷyd. From the confluence of these streams down to Pwll-du the valley is wide, and its gradient is so low that the velocity of the waters was never considerable. In this reach the banks show no signs of erosion, and even in two pronounced meanders above the farm of Pwll-du the stream-bed was not altered.

Stage II.—Below Pwll-du the banks of Boulder Clay were eroded and undercut at each bend of the stream, the flood again becoming heavily charged with small and large stones and boulders. When it reached the still waters of the storage-basin formed by the Low-level Dam, it spread out and dropped its load of boulders and finer material as a fan at the head and over about one-third of the total extent of the floor of this sheet of water.

Stage III.—The Low-level Dam was an earth-dam with a concrete core, concave towards the upland area. It was made of the local Boulder Clay with its included boulders, and was about 40 feet in height, with a spillway from the leat at the side of its southern end, some 4 feet lower. This leat collects waters from the flanks of Moel Eilio, below the Pwll-du leat, and brings them into the Low-level storage basin. The flood-waters from Llyn Eigiau banked themselves against the dam and increased the flooded area very considerably. Eventually they reached such a height that water overflowed the dam to a reputed height of two feet, and thus began to erode the piled-up Boulder Clay on the downstream side. This overflow in itself was not serious, but two feet of water over the dam gave a height of six feet above the by-wash or the spillway. The by-wash, though it could not accommodate all the flood, did send down a very large quantity of water which, rushing with unaccustomed velocity, cut into the toe of the earth-dam. Thus near the southern end of the dam the concrete core was probably exposed, and after an interval it broke. A gap 120 feet in width was made and a tremendous flood (11 million cubic feet of water) was suddenly released. It met the pipe-line mounted on its concrete pillars, buried that pipe-line in gravel, and was temporarily checked. The obstruction gave way in turn and the flood swept on to the Conway Valley. Sections of the pipe-line went with it, and some of the concrete piers were uprooted. Some of the material soon became stranded, but some made the whole journey to Dolgarrog, where it now forms part of the fan. The flood-water undercut the Boulder Clay on the rocky shelves, and, scouring them clean of all movable material, swept out loose supports and allowed joint-blocks of solid rock to move forward down the gorge. There is definite evidence that some very large blocks of rock were moved even at the top of the gorge. A boulder 15 by 15 by 15 feet, lying near the lip, still has dead vegetation attached to its under side, hanging head downwards. The boulder is trapped against joint-blocks of unmoved rock, and has caught and smashed a slab of slaty ash, which is now held beneath it. While it has not actually been proved that any large mass of the solid formation was carried to the foot of the gorge at Dolgarrog, this is considered possible. As a result of the under-cutting along the stream-course, the gradient has been disturbed and the slope locally made steeper than the angle of rest for joint-blocks; thus certain steeply inclined master-joints behind projecting masses have been given opportunity to open under gravity. During the flood, boulders fell into some of these gaping joints, and these may have acted as wedges. All this is well shown at the 'lip,' where evidence of the mighty power of the flood is particularly impressive.

Stage IV.—From the lip downwards, the most noticeable phenomena are the effects of the blows struck by the boulders which hit the solid rock in their tumble over the waterfall. New fractures, often triangular in form and many square feet in area, can be seen on projecting corners and edges all the way down to the slanting

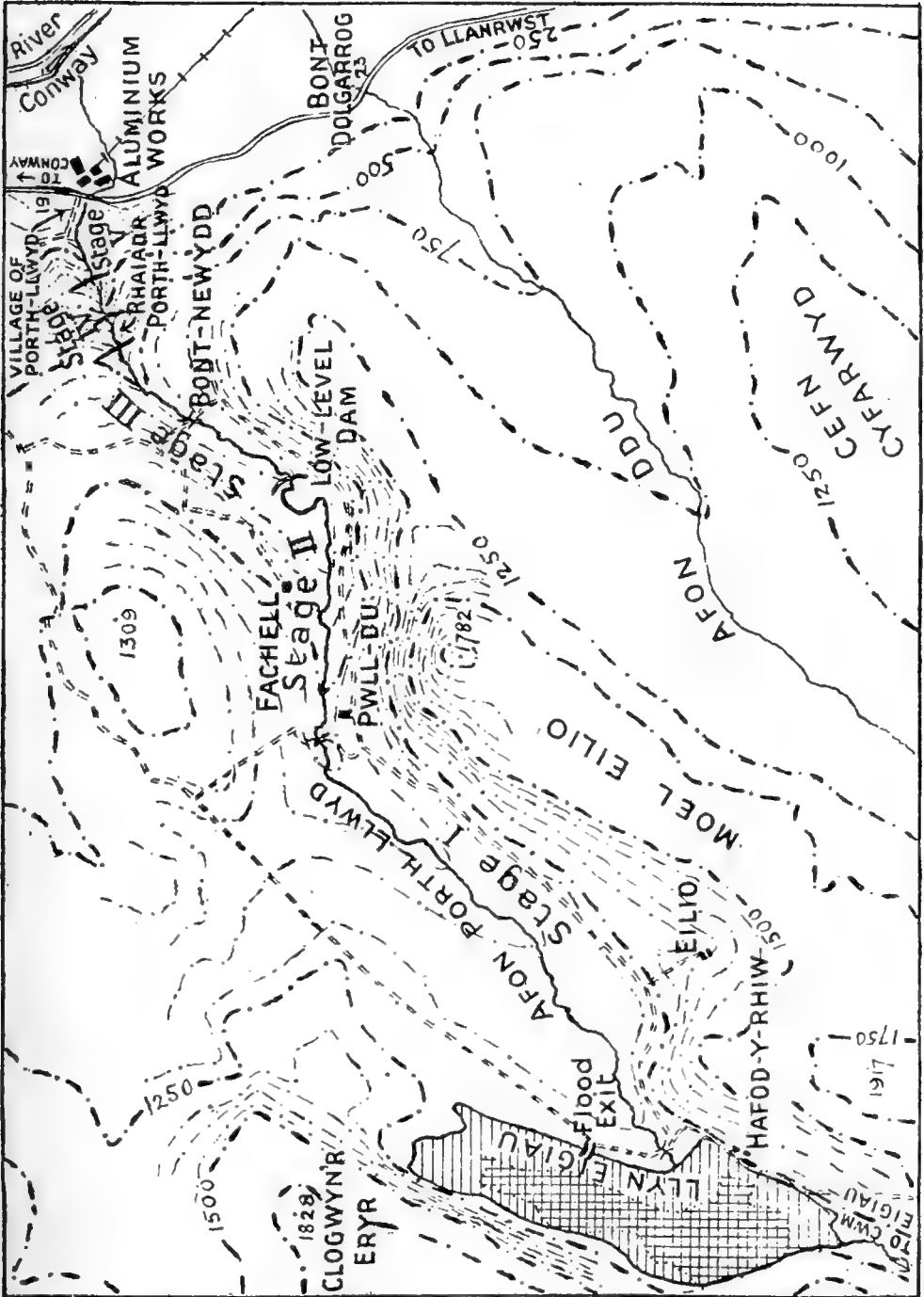

Sketch-map of Llyn Eigiau and Afon Porth-llwyd, Dolgarrog, showing the 'stages' referred to in the Report. Contours at 50-feet intervals on flanks only of valley of Afon Porth-llwyd.

The cross-hatched part of Llyn Eigiau shows the extent of the lake before the upper dam was constructed. It is approximately the present (or post-flood) outline also.

ledge. Many pot-holes drilled by the post-glacial pre-flood stream have had the down-stream lip battered and destroyed. Along this stage the flood met the bank of Boulder Clay infilling the pre-glacial valley and dislodged many very large boulders, which it carried through the steep and narrow ravine of Stage V and left upon the Dolgaŕrog fan. Several big erratics like those which are found in the fan below still project precariously from the Boulder Clay cliff, and two (of which one is estimated to weigh 200 tons) have fallen on to the ledge itself since the disaster.

Stage V.—In Stage V, although the whole of the surface of the upper parts of the gorge have been hammered, it is remarkable how little effect the battering has had on the rhyolite. Only projecting corners have been removed and there is no sign of any corrosion. In the narrow (lower) parts of the gorge the pre-flood surface with all its pot-holes remains practically unaffected. The black slates, on the other hand, gave way along their cleavage-planes, and slabs of moderate size were detached and carried forward in considerable volume. At about 250 feet above O.D., a reinforced concrete wall 10 feet in height and 6 feet in thickness had been erected to maintain a water supply for the village. Of this only a very small part now hangs on the southern bank. A view up the valley at this stage shows that the rocks near the stream-course have been smoothed, but all the higher parts of the ravine are raw and hackled like the face of a quarry from which every loose block has been removed.

The fan below the termination of the ravine is a wilderness of great stones standing at all angles. Many of these consist of the auto-brecciated basic rock which crops out across the upper part of the gorge. Practically all have shapes and surfaces like those of ice-borne boulders, and a few show pot-holes and smoothed water-channels, sufficient to prove that streams of water have flowed over them and to suggest that they have formed part of a river-bed. It is the opinion of the Committee that only the freshly fractured slate slabs and a few of the angular blocks of the 'lip' rocks were quarried by the flood out of the solid beds. The great majority are 'second-hand' boulders and were scoured by the falling waters from the Drift section on the ledge. One of these boulders measures 21 by 21 by 12 feet. It rests upon a smooth boulder of hard dolerite 24 inches in length and 8 inches in thickness, which it has broken into three pieces. At least four others are only slightly inferior to this in size and quite a score of others have more than half that bulk. The fan is rudely triangular in shape and extends across the former main road, where it is rather over 700 feet in width, the newly transported debris being there over 10 feet in thickness. A rough sorting action can be observed. Near the apex lie the biggest boulders. They decrease gradually in size to near the main road, where boulders of 6 to 8 feet in diameter are common. The finer material was spread over the alluvial plain in the direction of the River Conway. The present level of the fan at its apex is 100 feet above O.D. and on the road 26 feet above O.D. Under this large fan lie the remains of the wrecked church and of several houses. Over the position where the church stood, nearly 50 feet of material, including at least one 100-ton boulder, have been accumulated.

The Committee's task was to obtain photographic records of the geological results of the débâcle. Forty-three photographs are herewith submitted, most of which have been specially taken by Mr. W. H. Wilcockson, M.A., F.G.S., to whom the Committee wish to offer sincere and hearty thanks.

Vasoligation, Etc.—*Report of Committee (Dr. F. A. E. CREW, Chairman ; Mr. J. T. CUNNINGHAM, Secretary ; Professor J. S. HUXLEY) for the experimental Investigation of the Effects of Vasoligation, Cryptorchidism, Grafting, etc., on the Seminal Tubules and Interstitial Tissue of the Testes of Mammals.*

THE report submitted last year dealt with artificial Cryptorchidism and ligation of the vas deferens in the rabbit. The present Report contains some more experiments of the same kinds on the rat and cat, but describes chiefly experiments on the ligation of the vasa efferentia in tame rats, mostly of the albino variety.

It was desirable to carry out experiments on the ligation of the vas deferens in some animal in which the testis could not be withdrawn into the abdomen by the animal, either voluntarily or by reflex action, as in rodents, and the cat was selected for the purpose. By this means all doubt whether the result was due to the ligation or to the alteration of the normal relations of the testis to the scrotum, in other words to a partial or complete, temporary or permanent, dislocation of the testis into the abdominal cavity would be eliminated. It is difficult to find in the literature definite descriptions of the condition and relations of the inguinal canal in different mammals, but it is stated in Quain's Anatomy that the canal is actually closed only in the human species, in adaptation to the erect attitude. Dissection of a male cat showed that the cavity of the scrotum is connected with the abdominal cavity by a long narrow canal lined by peritoneum, and passing beneath the skin over the ventral surface of the pelvic girdle. The lumen of the canal was so narrow that only an ordinary seeker or probe could be passed through it, and there was no possibility of the testis passing into it or through it. There was no muscular layer in the wall of the canal, and very little muscle in the wall of the scrotum itself.

Ligation of the vas deferens in the Cat.

Urethane was tried as an anæsthetic for cats, but proved very unsuccessful. One cat injected with this drug died after the operation without recovering consciousness, another died during the operation. A successful operation was carried out by using chloroform and ether as anæsthetic. The scrotum on the right side was opened, the vas deferens ligatured in two places, and a piece between the ligatures cut out. The animal recovered quickly and lived in good health until it was killed with chloroform 104 days after the operation. The end of the vas next to the operated (right) testis was found to be closed, and the spermatic blood vessels uninjured. Abundant active sperms were obtained from the cauda epididymis of the left side. Sections of the operated (right) testis showed perfectly normal spermatogenesis.

The post-operative period stated by Bouin and Ancel to be sufficient to produce complete degeneration of the seminal tubules after ligation and vasectomy in the guinea pig was 102 days. In this experiment on the cat no injurious effect was visible after the lapse of 104 days. The epididymis of the operated side, as in similar experiments on the rabbit carried out last year, was distended with semen, its diameter being twice as great as that of the normal on the unoperated side. The testis and epididymis of the operated side showed slight congestion of the blood vessels, having a darker colour than the normal from this cause. This experiment confirms the evidence of the previous experiments on rabbits, and proves that ligation and resection of the vas deferens does not cause degeneration of the seminal tubules with cessation of spermatogenesis in the cat within a period of more than three months.

No further experiments were made on cats, as it was desired to test the effects of ligation of the vasa efferentia for comparison. For these experiments, as stated above, with one exception, albino rats were used. Complete descriptions of the position and relations of the vasa efferentia in the lower mammals have not been available until quite recently, but for man they are given in standard text-books of anatomy. In most cases (*e.g.* rabbit and cat) the epididymis and testis are so closely attached that the vasa efferentia cannot be distinguished by inspection of the surface, and it did not seem possible to pass a ligature round them with certainty. In the rat, Miss Gertrude van Wagenen, of the University of California (*Anat. Record*, Philadelphia, Vol. 27, 28, 1894, p. 189), has stated that the ducts are sufficiently discrete to permit complete ligation without interfering with the blood supply to the testis. She states

that they consist of twelve to twenty thin walled ducts which pass from the head of the testis to the caput epididymis. Observation in the dead animal showed that the epididymis is connected to the testis by a membrane about $\frac{1}{4}$ in. broad, which is somewhat thickened where it terminates between the free extremity of the caput and the head or anterior end of the testis. It seemed that this was the site of the vasa efferentia indicated by Miss de Wagenen, and experiments were made to test the effect of ligation of this thickened membrane, while at the same time microscopic investigation was made to trace the vasa efferentia completely and certainly.

In the first experiment the rat was killed three weeks after the operation and sections of the testis showed complete disorganisation of the seminal epithelium in the tubules. It seemed therefore that this was the actual position of the vasa efferentia, but this is not the case.

The vasa efferentia in the Rat.

Shortly afterwards the number and course of the vasa in the rat were ascertained by two methods, namely, by making cleared preparations of the whole membrane containing them, from their origin from the testis to their junction with the caput epididymis, and by making serial sections from the anterior end of the caput to the portion of the testis containing the rete and the origin of the vasa. The number of the vasa at their origin was found to be six, not twelve to twenty, as stated by Miss de Wagenen, and at their origin from the rete they are straight. Farther on they become more and more convoluted and form a bundle which increases in thickness, passes dorsal to the epididymis, and joins the caput on its anterior border. The inner end of the caput is, in fact, formed by a continuation of the bundle of the vasa efferentia which bends back on itself and is continued into the body of the epididymis. Where the vasa efferentia join the caput epididymis they are united into a single tube, which is continued in a much convoluted but unbranched condition to form the whole epididymis.

It was afterwards found that these observations are in agreement with those of Dr. Jacques Benoit,¹ of the Faculty of Medicine of Strasburg. Mr. Cunningham also examined the corresponding parts in the mouse where the relations are very similar. In the specimen examined, the number of vasa efferentia was only three; Benoit found four or five in the majority of cases, three in two specimens, and six in one.

The vasa efferentia in the rat leave the testis somewhat behind the anterior extremity, near the point where the spermatic artery and vein enter it, and they pass obliquely forward in the connecting membrane between the epididymis and testis. The operation of ligaturing the vasa offered no great difficulty as they were not closely connected with the vascular cord formed by the spermatic artery and vein.

A number of experiments on ligation of the marginal membrane were made in order to ascertain whether disorganisation of the seminal epithelium, as in the first experiment mentioned above, was a constant result. The following is a list of these experiments:—

Experiments on ligation of marginal membrane.

Marginal membrane in Rat ligatured on right side only.

	Post-operative period.	Result.
1.	21 days.	Seminal epithelium disorganised. Weight of normal, left, testis 2.5 gms., operated right, 1.3 gms.
2.	14 days.	Ligatured testis functional, but larger than the other. In sections a few tubules slightly abnormal, but the great majority showed normal spermatogenesis.
3.	7 days.	Active spermatozoa in vas deferens of operated side. In sections of operated testis normal spermatogenesis, except in a few tubules.

¹ Benoit, Dr. Jacques. 'Voies excretrices du testicule chez les Mammiferes. Strasburg, Imp. Alsacienne, 1925.

Post-operative period.	Result.
4. 14 days.	Normal spermatogenesis in right testis.
5. 17 days.	Seminal epithelium completely disorganised and reduced in right testis. Left, normal.
6. 20 days.	Sperms from right vas deferens dead and motionless. In sections very slight signs of abnormality in a few tubules, otherwise normal spermatogenesis.

Marginal membrane ligatured on left side. Right testis detached from scrotum and fixed to abdominal wall by ligature passing through gubernaculum.

Post-operative period.	Result.
7. 16 days.	Right testis atrophied and degenerate, only about half the size of the other, seminal epithelium completely disorganised. Left testis functional, the ligature loose.

Of the first six experiments, leaving out of consideration that in which the other testis was removed from the scrotum to the abdomen because in that the ligature was found to be loose, there was complete disorganisation of the seminal epithelium in two, the first and fifth; normal spermatogenesis in one, the fourth; and slight traces of disorganisation in a few tubules in three. Careful examination by sections and cleared preparations showed nothing in the marginal membrane but lymphatic channels and small blood-vessels. It is probable that the injurious effects of ligature of this membrane are due to varying degrees of injury to the tubules of the apex of the caput epididymis to which the membrane is attached.

The following is a list of the experiments in which the true vasa efferentia were ligatured:—

Experiments on ligation of vasa efferentia.

Vasa efferentia ligatured on left side, marginal membrane on the right.

Post-operative period.	Result.
1. 6 days.	Testis of each side flaccid and reduced in size. In sections, seminal epithelium in both testes disorganised, no spermatogenesis.

Vasa efferentia ligatured on right side only.

Post-operative period.	Result.
2. 14 days.	Seminal epithelium completely disorganised. Weight of right testis 1.535 gms., left 2.200 gms.
3. 14 days.	Seminal epithelium completely disorganised.
4. 7 days.	Seminal epithelium completely disorganised, but not so much reduced. No spermatogenesis.

These experiments show that closure of the lumen of the vasa efferentia causes complete disorganisation of the seminal epithelium in seven days, or even in six days, assuming that the evidence of the first experiment is valid. In the other three the left testis served as control, and showed perfectly normal spermatogenesis. As there was no interference with the blood circulation in the testis, the effect must be due to increase of pressure within the tubules. It follows therefore that when the vas deferens only is ligatured, the absence of injurious effect is due to the fact that the great space contained in the long coiled tube of the epididymis prevents this increase of pressure in the seminal tubules, the epididymis acts as a reservoir for the semen and becomes greatly distended in consequence. The conclusion is that when the distension and pressure increase to a certain point within the epididymis, absorption of semen is increased, an equilibrium is reached, and no further rise of pressure occurs.

Zoological Bibliography and Publication.—*Report of Committee* (Prof. E. B. POULTON, *Chairman*; Dr. F. A. BATHER, *Secretary*; Dr. W. T. CALMAN, Mr. E. HERON-ALLEN, Dr. P. CHALMERS MITCHELL, Mr. W. L. SCLATER).

DURING the past year inquiries have continued to reach your Committee on various points of detail and have been answered by letter and by sending the relevant report. In particular the Committee was consulted by the Editor of the Journal of the South-Eastern Agricultural College, and he has adopted many of the suggestions made.

The Committee notes with pleasure the publication, by the Oxford University Press in 1925 and 1927, of the *World List of Scientific Periodicals* (1900–1921), and strongly urges that in the making of brief references to literature the contractions used for the titles of periodicals should always be those which have been most carefully drawn up by Dr. A. W. Pollard and Mr. W. A. Smith, and printed in the second volume of that work. Authors and editors should at least make themselves acquainted with the rules and principals of abbreviation explained on pp. ix, x of that volume. To aid them in so doing, we are permitted, by courtesy of the Council of Management of the *World List*, to reproduce those pages as an Appendix to this report.

The Committee also welcomes the establishment of a Committee on Bibliography by the International Institute of Intellectual Co-operation. In the deliberations of the section dealing with the bibliography of the biological sciences Dr. Chalmers Mitchell, a member of your Committee, has already taken part.

Your Committee asks for its reappointment with a grant of £1 for postage of this report.

APPENDIX.

ABBREVIATION OF TITLES OF PERIODICALS.

Reprinted from the *World List of Scientific Periodicals*.

Titles of periodicals have been abridged on a plan which, it is hoped, will enable users of the Index to reconstruct all of any reasonable length. It will be a great satisfaction if for titles using commonly recurring scientific and technical phrasing stable abbreviations have been achieved. For less common technical titles this is hardly to be expected, but even here, it is hoped, some progress has been made towards a consistent usage.

Prepositions and articles are normally omitted. In English titles capitals are used throughout. In other languages nouns have capital, adjectives small, initial letters :

Bull[etin of the] Sci[entific] Soc[iety of] N[ew] Y[ork].
Pub[lications de la] Soc[iété] sci[entifique de l'] Aisne.

The conjunction 'and' (with the corresponding words in other languages) is omitted, except in titles consisting only of two nouns connected by 'and', and where it connects broken compounds :

Coal and Iron.
land- u[nd] forstw[irtschaftliche] Bl[ätter].

Number is not distinguished (Bl.=Blatt and Blätter); nor in English is any distinction attempted between substantive and adjectival forms (Sci.=Science, Sciences, and Scientific). Where possible, cognate words in all languages are reduced to the same form :

Academy, Académie, Academia	> Acad.
Annals, Annales, Annalen, Annali	> Ann.
Science, Scienza, Scienza	> Sci.
Society, Société, Società, Sociedad, Sociedade, Societas, Societate, Societät	> Soc.

Normally the place of imprint is omitted (except when needed to distinguish periodicals with the same title); but when the abbreviated form would leave it uncertain what was the language of the original, the imprint is added for all except the best-known language of those between which confusion could arise, taking the order of familiarity as being : (i) English ; (ii) French ; (iii) German ; (iv) Italian or Spanish.

So :	Progress of Science, London.	> Prog. Sci. (Without imprint.)
	Progrès des sciences, Paris.	> Prog. Sci. Paris.
	Progresso delle scienze, Torino.	> Prog. Sci. Torino.
	Progrès scientifique, Paris.	> Prog. sci. (Without imprint, since there is no confusion with English.)
	Progresso scientifico, Milano.	> Prog. sci. Milano.
	Annales de biologie, Paris.	> Ann. Biol. Paris.
	Annales de chimie, Paris.	> Ann. Chim.
	Annalen der Chemie, Berlin.	> Ann. Chem. Berl.

In the Germanic and Scandinavian languages where long compound words occur freely the different parts of the compound have been abbreviated as if they were distinct. With nouns no hyphen is used between the parts but each part is made to begin with a capital letter :

Entwicklungsmechanik	> EntwMech.
Materialprüfungen	> MatPrüf.
Fiskeritidende	> FiskTid.
Dampfkesselüberwachungsvereine	> DampfkÜberwVer.

Compound adjectives are similarly contracted, but between the parts a hyphen is inserted.

agrikulturrekonomisch	> agrik.-ekon.
technischwissenschaftlich	> tech.-wiss.

It is not considered necessary to give a list of the abbreviations, as most of them are self-explanatory and reference can be made to the full form. Exception is made of the following German forms, some of which differ somewhat from those in common use

Bl.	= Blatt.	Zbl.	= Zentralblatt.	Mschr.	= Monatschrift.
Mbl.	= Monatsblatt.	Mhft.	= Monatsheft.	Wschr.	= Wochenschrift.
Wbl.	= Wochenblatt.	Schr.	= Schrift.	Ztg.	= Zeitung.
		Z.	= Zeitschrift.		

and of the following place-names :

Aberd.	= Aberdeen.	F.M.S.	= Federated Ma-	N.Z.	= New Zealand.
Afr.	= Africa.		lay States.	Nebr.	= Nebraska.
Amer.	= America.	Finl.	= Finland.	Okla.	= Oklahoma.
Amst.	= Amsterdam.	Fr.	= France.	Ont.	= Ontario.
Ariz.	= Arizona.	's-Grav.	= 's-Gravenhage.	Penn.	= Pennsylvania.
Aust.	= Australia.	Ind.	= India.	Philad.	= Philadelphia.
B. Aires.	= Buenos Aires.	Ire.	= Ireland.	Qd.	= Queensland.
B.C.	= British Colum-	Ital.	= Italia.	R.I.	= Rhode Island.
	bia.	Kans.	= Kansas.	Rhod.	= Rhodesia.
Beig.	= Belgique.	Kjøb.	= Kjøbenhavn.	Rio de J.	= Rio de Janeiro.
Berl.	= Berlin.	Krist.	= Kristiania.	St. Petersb.	= Saint Peters-
Bgham.	= Birmingham.	Lond.	= London.		burg.
Brux.	= Bruxelles.	Lpool.	= Liverpool.	Saskatch.	= Saskatchewan.
Buitenz.	= Buitenzorg.	Madr.	= Madrid.	Scot.	= Scotland.
Calif.	= California.	Manchr.	= Manchester.	Stockh.	= Stockholm.
Can.	= Canada.	Mass.	= Massachusetts.	Tasm.	= Tasmania.
Carol.	= Carolina.	Mex.	= Mexico.	Tex.	= Texas.
Colo.	= Colorado.	Mich.	= Michigan.	Transv.	= Transvaal.
Conn.	= Connecticut.	Minn.	= Minnesota.	Trin. Tob.	= Trinidad and
Dak.	= Dakota.	Miss.	= Mississippi.		Tobago.
Deuts.	= Deutschland.	N.S.	= Nova Scotia.	Vict.	= Victoria.
Edinb.	= Edinburgh.	N.S.W.	= New South	Wash.	= Washington.
Engl.	= England.		Wales.	Wisc.	= Wisconsin.
Esp.	= España.	N.Y.	= New York.	Wyom.	= Wyoming.

Biological Measurements.—*Report of Committee* (Prof. J. S. HUXLEY, *Chairman*; Dr. R. A. FISHER, *Secretary*; Dr. W. T. CALMAN, Mr. C. FORSTER-COOPER, Prof. J. W. NICHOLSON, Dr. E. S. PEARSON, Mr. O. W. RICHARDS, Mr. G. C. ROBSON, Dr. J. F. TOCHER) *appointed to draw up recommendations for the taking and presentation of Biological Measurements, and to bring such before persons or bodies concerned.*

THE Committee held six meetings during 1926 and 1927. Preliminary discussions showed that two obstacles ordinarily stood in the way of the satisfactory presentation of numerical data in the biological literature. In the first place editors showed a natural reluctance to printing extensive data in full detail, especially when every advantage had not been taken to arrange such data as compactly as possible; in the second place the methods available for providing a statistical summary, such as is essential wherever the original data are not presented in full, are neither sufficiently well known nor have been sufficiently standardised by accepted conventions for such summaries to have an exact and unambiguous meaning.

The Committee decided that these obstacles could be overcome by action along two lines: (a) by the establishment of centrally placed archives for the reception of original biological data, which were too extensive for complete publication, and (b) by the preparation of a leaflet for the guidance of contributors to biological journals who wish to conform to acceptable modern practice. It is anticipated that this leaflet will require periodical revision as need arises.

Negotiations with the Natural History Museum at South Kensington and with the Royal Society of Edinburgh have resulted in the establishment of the required archives for the reception of biological data, where they will be available to students, and in this sense will have secured effective publication. The thanks of the Committee are due to the authorities of these two institutions for undertaking a function which in the opinion of the Committee will be of increasing value to biological science.

The leaflet prepared by the Committee consists of a foreword illustrating the practical needs of modern biological work, followed by four sections (A) on general considerations in the planning and execution of research by metrical methods, (B) on the methods available for the compact presentation of data, and on the recognised methods by which it can be adequately summarised, (C) on the interpretation of statistical results and on tests of significance, and (D) giving detailed references to text books upon the several types of tests generally required. The leaflet is presented as an appendix to this report.

Seeing that the practical utility both of the archives and of the leaflet will depend on their existence becoming known to biological workers, the Committee have circularised the editors of the chief biological journals published in Great Britain asking for the incorporation of additional clauses in their permanent notices to contributors. The Committee are glad to report that a favourable reply has been given by the editors of a number of important journals.

Recommendations of the British Association Committee on Biological Measurements.

FOREWORD.

Biology is rapidly becoming more and more of a science in which exact mathematical methods are required. In all fields accurate measurements or quantitative data of some kind are being increasingly employed. On the other hand, such data are not infrequently rendered useless, or at least much less useful than they might have been, through neglect of simple precautions, either in the making, the recording, or the analysis of the data. Bearing these facts in mind, Section D of the British Association appointed the present Committee to draw up recommendations upon the presentation of biological measurements.

The chief fields in which statistical data, properly taken and analysed, can be of great service are perhaps the following :—

(a) *Genetics*.—Obviously, here all conclusions based upon ratios are valid only in so far as statistically significant. In the early days of Mendelism much confusion was brought about through lack of proper statistical treatment. It has, however, recently become increasingly realised that a combination of Mendelian and statistical (biometric) methods is in many cases necessary for full analysis. In human genetics the statistical method is the main available weapon.

(b) *Variation*.—Here the achievements of biometrics are too well known to need statement or comment. It should be pointed out, however, that in many cases a technically perfect biometric analysis may tell us less than it ought owing to inadequate selection of material. *E.g.* without experiment, biometric methods cannot tell us how much of a given variation range is genotypic, how much phenotypic. Only properly directed work on variation can give us much needed information as to the differences between different species as regards variability, the reasons for the differences, and the bearing of the facts upon evolutionary theory.

(c) *Systematics*.—With increased delicacy of systematic determination, measurements are becoming more and more important as a criterion of the distinctness of closely related species, sub-species or races.

(d) *Development*.—Only by taking large numbers of measurements will it be possible to discover the laws of relative growth of parts.

(e) *Evolution*.—As more perfect palæontological series are obtained, accurate measurements of absolute and relative sizes of parts may enable us to establish simple laws of evolutionary growth and development comparable to those which are being obtained by similar methods in ontogeny.

Naturally the taking of quantitative data constitutes the essence of much of physiology ; but we have here been concerned mainly with data which may be called statistical.

It may be as well to begin by enumerating a few of the cases in which neglect of simple precautions has made laboriously taken measurements of much less value than they might otherwise have been ; for such examples will serve better than anything else to convince the working zoologist of the need for improvement. The defect may have lain in the failure to take the most suitable measurements, to record them adequately when taken, or to analyse them in the most desirable way.

A. NEGLECT OF BIOMETRIC ANALYSIS. (See also No. 2.)

1. In the preparation of Witherby's 'Handbook of British Birds' (London, 1922) considerable numbers of accurate measurements were made both upon the skins (usually twelve specimens) and eggs (usually 100 specimens) of a large number of species of birds. However, in recording these valuable data only the mean and high and low extreme variants were set down (in the case of skins, the mean was omitted). Presumably the main purpose of such measurements is to give the systematist help in distinguishing between closely related forms (sub-species, races, &c.). Even for this purpose, however, and especially when the ranges of two forms overlap, this method of record is markedly inferior to one giving mean and standard deviation. In addition, the recording of standard deviation would have enabled a wholly different and very interesting problem to be attacked, namely, the suggestion originally made by Darwin ('Origin of Species,' chapter ii) that wide ranging and abundant species and genera are more variable than scarce and local ones.

B. NUMBERS INADEQUATE FOR THE STATISTICAL CONCLUSIONS DRAWN.

2. Examples of the failure to realise the statistical invalidity of small numbers are frequent. *E.g.* Krüger (1920 and 1924, *Zool. Jahrb. (Syst.)*, 42, 289, and 48, 1) distinguishes closely related 'species' of Humble-bees by means of certain relative proportions of parts. Considering, however, that the maximum number of any one species measured is 25, and is often below 10, that the ranges frequently overlap, and that only mean, maximum and minimum are recorded, it may be doubted whether these quantitative results are at all significant.

3. If data are properly taken and recorded, failure to use suitable analyses can be remedied by subsequent workers. Nevertheless, conclusions based on unsatisfactory analysis often, as a matter of fact, become generally accepted, and it is then difficult to correct the error. The most frequent source of error is failure to discount chance

or random sampling. A well-known case of this is afforded by the paper of Pearl and Parshley (1913, *Biol. Bull.* 24, 205), who believed that they had clear evidence that in cattle the relation of time of insemination to the cyclical events of oestrus influenced the sex-ratio. Later investigation of a larger body of material, however, convinced them that their first result had been wholly due to chance (Pearl, 1917, *Maine Agri. Exp. Station Bull.* 261, (3), 130).

C. INCOMPLETE RECORD OF ADEQUATE DATA.

4. Very often the investigator is so much preoccupied with the solution of a particular question that he is content to record his data incompletely, provided that this will suffice for his special problem. He fails to remember that complete record may make it possible for later investigators to use his original data for the solution of quite new problems. A good example of this is afforded by the classical paper of Bateson and Brindley (*Proc. Zool. Soc.* 1892, 285) upon dimorphic organs. The authors were concerned to prove that in the beetle *Xylotrupes*, while the frequency-curve for body-length was of normal type, that for cephalic horn-length was bimodal; but that in the stag-beetle *Lucanus* both body-length and mandible-length showed normal frequency distributions. The frequency distributions of these four characters were therefore given singly. Since, however, two measurements were taken and recorded for each individual, it would have been possible to present not only the information immediately required, but also all information bearing on the correlation between body-length and appendage-length, by means of two-way tables. This information was later required by another investigator: luckily the original data had been preserved, and so new conclusions could be drawn (*J. Genetics*, 1927, 18, 45). A precisely similar failure to record by means of two-way tables is found in the paper by Djakonov (*J. Genetics*, 1925, 15, 201) on the bimodality of forceps-length in male earwigs (*Forficula*). Here again only lucky chance preserved the original data, which were then found to yield new results (*J. Genetics*, 1927, 17, 309).

5. Frequently not merely are data published in an incomplete way, but owing to lack of space or for other reasons are not published at all. The danger of this procedure may be illustrated by the benefits accruing from its converse. Haldane (*J. Genetics*, 1920, 10, 47) was able to demonstrate from Nabour's data on heredity in the grasshopper *Paratettix* (*J. Genetics*, 3, 141, and 7, 1) that two factors which the original investigator had thought to segregate independently were in reality linked. He expressly states that this would not have been possible if it had not been for the exceptional fullness of Nabour's records.

6. Duncker (1903, *Biometrika*, 2, 307) re-analysed the figures of Yerkes (1901, *Proc. Amer. Soc. Arts and Sci.* 36, 417), which involved the careful measurement of a number of characters on eight hundred Fiddler-Crabs (*Gelasimus*). Neither author published the data in full; and since they were utilised only for certain special purposes, the very fundamental growth-relations between the various organs were not brought out. Duncker himself points out that asymmetry of all the organs on the side of the large chela increases with absolute body-size, but does not tabulate the figures by size classes. It is therefore impossible to arrive at the laws of growth underlying the phenomena. Duncker calculates a number of correlation coefficients from which he deduces certain conclusions. The conclusions would have been much more firmly based, however, if the underlying growth-laws had also been established, as only by so doing can we hope to understand the biological, as opposed to the statistical, meaning of the coefficients. This therefore represents a failure not only to publish the data in full, but also to analyse the data sufficiently fully even for the purpose envisaged by the author.

D. FAILURE TO CHOOSE THE MOST SUITABLE MEASUREMENTS OR CONVENTIONS.

7. Sometimes data are less valuable than they should be because the points of reference used in making measurements are chosen arbitrarily instead of conforming to an accepted standard, or of being chosen with reference to their biological significance.

An example of the latter procedure is shown by two recent authors (Nomura, 1926, and Sasaki, 1926, *Sci. Report Tohoku Imp. Univ.* 2, 57 and 197) who have made elaborate measurements of a number of Molluscan shells, with a view to the analysis of relative growth of parts. The results, however, would have been more valuable if measurements had been made of the magnitudes needed for determining the mathematical growth relations of a Molluscan shell, as set forth for instance in D'Arcy Thompson's 'Growth and Form' (Cambridge, 1917), chapters xi and xii.

E. FAILURE TO MAKE THE MOST SUITABLE BIOLOGICAL ANALYSIS. (See also No. 6.)

8. A further example of failure to analyse data in the best way owing to lack of the most suitable preliminary biological method (the statistical method being wholly adequate) is afforded by a paper by Pearl, Gowen and Miner (1919, *Maine Agric. Exp. Sta. Ann. Rep.*), who in calculating the influence of bulls on the milk-production of their female descendants takes as a measure of the bull's performance: daughter's yield minus mother's yield. This clearly gives an undue advantage to bulls mated to cows of low milk-yield. The error here has practical consequences, since the market value of the bulls would be altered in relation to the verdict of the scientist.

9. As Klatt (1919, *Biol. Zentrab.* 39, 406) points out, failure to realise that other relations than that of simple proportionality may, and usually do, hold between the size of an organ and the size of the whole organism vitiates many discussions as to the relative size of organs in different types within one group. The usual plan is to express relative organ-size as a percentage of total size. Since, however, a frequent relation of organ to body is not $y = ax$, but $y = ax^b$, this is of no value. Parrot (1894, *Zool. Jahrb. (Syst.)* 7) had arranged a series of birds in a scale according to their percentage heart-weights. Klatt, having previously found that the heart-weight (h) of warm-blooded vertebrates was related to the body-weight (w) according to the exponential formula $h = a.w^b$ where a varied considerably, but b was always close to 0.83, re-analysed these figures, and was thus enabled to calculate the real relative heart-weight, which is given by the size of the fractional constant a in the above formula. Thus, for instance, the stork has a moderately low percentage heart-weight, but this is due to its large absolute size. When the value of a is calculated by the correct method, its true (physiological) relative heart-weight turns out to be one of the three highest in the list.

10. In general, measurements reveal the fact that in many groups there are no final fixed proportions of parts (*e.g.* many Crustacea), and that the only quantitative constants which are of value are not percentages but exponents. This is true even of certain Mammals ('Monograph of the Voles and Lemmings living and extinct,' M. A. C. Hinton, vol. i, 1926).

D'Arcy Thompson ('Growth and Form,' chapter ii) gives an historical and critical account of many similar cases where absolute size must be taken into consideration in assessing the functional meaning of particular relative sizes of parts.

A. General Considerations.

1. IDENTIFICATION.

The material under investigation should be examined by exact taxonomic methods and care should be taken that the series of specimens dealt with are, so far as possible, correctly identified. The advice of an expert in the group under consideration should be sought if necessary.

2. CHARACTERISTICS OF THE POPULATION SAMPLED.

The examination of a sample only supplies direct information respecting the population *as sampled* by the methods of collection employed, or, in other words, the population from which such a sample may be regarded as fairly drawn at random. This may often differ materially from:—

- (i) the whole population living at the time of capture, owing, for example, to selection of sex, age or size by the methods of capture;
- (ii) the average population ordinarily living in the same habitat, owing, for example, to seasonal or other periodic fluctuations; and
- (iii) the populations of different habitats in the same region.

The results of the examination of a sample should therefore be supplemented with all possible care by information designed to specify the population sampled, even though such specification is undoubtedly often difficult. The aim should be that any significant (see Section D) discrepancies between samples obtained by different investigators should be assignable to their true causes, whether age, sex, local variation, time, season, method of capture, &c.

These should always be specified where possible, but in every investigation special points will need to be considered.

3. CONFORMITY TO PREVIOUS MEASUREMENTS.

Whatever other measurements may be made, the value of the work for comparative purposes will often be much increased by the inclusion of measurements which are comparable, as strictly as possible, with those taken in the same or related species by previous workers.

It is desirable that some quantitative measurements should always be presented with general biological data. Length measurements are the most usual. However, a frequent 'failure to record' is seen in microscopical figures to which no record of magnification is appended. For example, in the article on *Rotifera* in the Cambridge Natural History and in the Encyclopædia Britannica no magnification is given in any of the figures, nor are any measurements given in the text, so that the reader (*inter alia*) will not be told, nor able to find out for himself, the interesting biological fact that the *Rotifera* have the lowest average size and the smallest size range of any considerable Metazoan group.

The most satisfactory way of giving magnifications is to reproduce with the figure some unit of length magnified to the same scale. This obviates the error which frequently creeps in when figures from one source are reproduced in another publication on a different scale, but without altering the statement as to magnification in the legend.

In addition measurements of weight or volume should be made whenever possible as a matter of routine, since they provide the best standard of quantitative comparison between differently shaped organisms or organs.

4. SPECIFICATION OF PRECISE CONVENTIONS.

It is essential to specify the conventions, including any points of reference adopted, by which each measurement is defined. This can often best be done by the aid of a diagram. When satisfactory standard terms, conventions or points of reference already exist they should be adopted whenever possible. The aim should be to ensure that a second observer, working over the identical material, and guided only by such specifications, should normally obtain significantly similar results.

The state of preservation of the material may often affect the measurements, especially in the case of soft parts. Accordingly the method of preservation and the degree of contraction or relaxation of the parts should be noted.

Observations of colour should when possible be referred to one of the standard scales in general use, e.g. 'Nomenclature of colours for naturalists,' R. Ridgeway, U.S. National Museum, 1912; 'Code des couleurs à l'usage des naturalistes, artistes, commerçants et industriels,' P. Klinksieck, Paris, 1908.

5. TESTS OF SIGNIFICANCE.

The critical stages of the statistical examinations of a body of data are reached in the application of what are known as tests of significance. (See Section D, 3-8.) These are essentially tests whether the difference between two (or the variance among several) groups is or is not greater than can with reasonable probability be ascribed to the variability found within each group. The ultimate value of the conclusions to be drawn from any data depends upon the precision and validity with which such tests can be carried out; consequently it is advisable that investigators, whether or not they undertake the work of statistical analysis, should have a general acquaintance with the nature of such tests, and, where the case does not seem clear, should seek the advice or co-operation of a statistician.

B. Presentation of Data.

1. An incomplete specification of a sample is never to be preferred to a complete specification, e.g. greatest, least and mean length is an incomplete specification (see below).

2. SINGLE-VARIATE DATA.

For a single measurement a complete specification of a sample may be given by recording the number of cases observed to fall in successive intervals of magnitude.

Example : Length of cuckoo's egg (after O. H. Latter).

Length class, mm.	19.0	19.5	20.0	20.5	21.0	21.5	22.0	22.5	23.0
Frequency	1	3	33	39	156	152	392	288	286
Length class, mm.	23.5	24.0	24.5	25.0	25.5	26.0	26.5	Total	
Frequency	100	86	21	12	2	0	1	1572	

A series of numbers arranged in this way form what is called the frequency distribution of the sample.

The total of 1572 eggs is distributed in 16 length classes, each with a range of half a millimetre, each class being specified by its central length. Thus the entry under 21.5 mm. indicates that 152 of the eggs measured were judged to lie between the precise limits 21.25 and 21.75 mm. The class range need not be equal to the unit of measurement, but should be (either one unit or) an integral number of such units ; the table above was condensed from a record giving the length to 0.1 mm.

A fruitful source of bias is avoided, at the time the measurements are actually taken, by using length classes bounded by the divisions marked on the measuring instrument used, instead of the more common practice of using length classes centred on visible divisions, and bounded by imaginary ones. The effect of the latter procedure appears to be especially noticeable in micro-measurements. If working with length classes of 1 mm. adopt class boundaries of 0-1, 1-2, 2-3 mm., &c., with class centres at 0.5, 1.5, 2.5 mm., &c. If working with length classes of 0.5 mm. adopt class boundaries of 0-0.5, 0.5-1.0 mm. &c., with class centres at 0.25, 0.75, 1.25 mm., &c.

Measurement groups free from bias, bounded by divisions which can be accurately visualised.

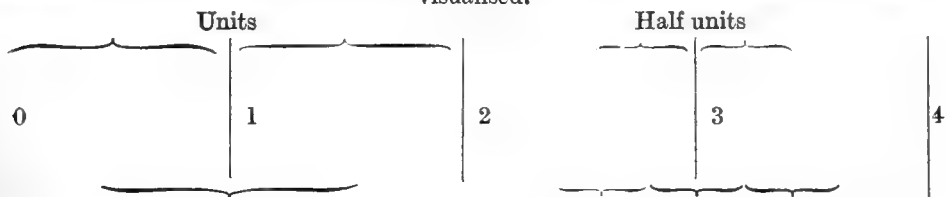

Groups usually employed, centred on divisions which can be accurately visualised, but bounded by imaginary divisions.

The use of small units is less important than accuracy of the class boundaries, and it is above all essential that these boundaries should be clearly indicated. For example, headings such as these are ambiguous :

Age	6 years	7 years	8 years
Frequency	15	38	62

It is impossible to tell whether the 38 individuals were between 7.0 and 8.0, or between 6.5 and 7.5 ; the former interpretation adhering to the popular convention of age, the latter to the scientific convention of specifying the central measurement of each class.

In the choice of the class interval, which should be uniform throughout, little additional information is supplied by a very fine classification ; for material which is apparently homogeneous a class interval equal to a quarter of the Standard Deviation is sufficiently small ; this will usually be provided for by dividing the material into about 20-25 classes. Coarser groupings are by no means valueless. To bring out the peculiarities of heterogeneous material finer grouping will sometimes be required. Small samples should not be grouped more coarsely than large samples. Extreme measurements should never be pooled as, e.g., 'more than 25 mm.' ; since in the statistical treatment the precise determination of these is of particular importance.

3. SUMMARY OF SINGLE MEASUREMENT DATA.

If space does not allow a complete specification of the observations, these may be summarised by means of a few quantities calculated from them ; each of these quantities is technically termed a *statistic*. If this course be taken, great care and some additional knowledge will be needed to make the summary adequate. For instance, the mean and range of the lengths of the individuals of a sample contain only a small

BREADTH OF EGG (CM.).
CENTRAL VALUES OF 13 BREADTH CLASSES.

CORRELATION TABLE.
LENGTH OF EGG (CM.). CENTRAL VALUES OF 23 LENGTH CLASSES.

	1	3	2	8	16	58	114	228	193	213	76	34	10	Totals.
2-675	1													4-675
2-725		2												4-625
2-775			1											4-575
2-825				1										4-525
2-875					1									4-475
2-925						1								4-425
2-975							1							4-375
3-025								1						4-325
3-075									1					4-275
3-125										1				4-225
3-175											1			4-175
3-225												1		4-125
3-275													2	4-075
Totals	1	2	1	1	2	3	4	5	6	7	8	8	5	956

fraction of the information available from the original data, and for this reason, if they be recorded alone, needless inaccuracy is introduced.

For an important class of cases of homogeneous samples, an adequate summary may be given by stating two statistics only; namely, conventional estimates of the mean and the variance of the population sampled.

(a) The *arithmetic mean* of the measurements, defined as the sum of the measurements divided by their number.

(b) An estimate of the variance calculated from the sum of the squares of the deviations from the arithmetic mean by dividing it either by (i) the number of individuals in the sample, n , or by (ii) one less than this number, $n-1$. With large samples it is seldom of importance which divisor is adopted, and the former method has been the more widely employed in biology. Attention is called to the latter method for no other reasons than that: (A) it is somewhat the more accurate in using the Normal probability function of tests 5 (a) and 6 (a) (Section D), if the variance there employed has been estimated from the sample; (B) it is upon this convention that the table of t for tests 5 (b) and 6 (b) has been calculated; (C) it alone should be used when it is desired to average the variance as estimated from several independent samples.

From the variance two other quantities may be calculated: (i) the Standard Deviation is the square root of the variance; (ii) the *sampling variance of the mean* may be estimated by dividing the variance as estimated from the sample by the number in the sample; this measures the amount of variability to be expected among means of different samples of the same size drawn fairly from the same population; its square root provides an estimate of the *Standard Error of the mean*. Large samples, if equally homogeneous, will consequently enable finer distinctions to be drawn than can be detected with confidence in smaller samples.

For samples of the normal form (Section D, 4) the two quantities (a) and (b) provide a complete statistical summary. Such a summary, though often valuable, cannot be regarded as complete when the distribution of the sample is unsymmetrical, or in other ways differs clearly from the normal form.

4. BIVARIATE DATA.

If two measurements are taken on each individual the sample may be *completely specified* in a two-way or correlation table. The arrangement of such a table may be illustrated by the example on page 292.¹ In the table are recorded the measurements of the Length and Breadth in cm. for each egg in a sample of 956 eggs of the common Tern (*Sterna Fluvialis*). The class interval is .05 cm. for each measurement. The table shows, for example, that 18 eggs were found with a breadth between 2.95 and 3.00 cm. and a length between 4.05 and 4.10. The figures in the two margins give the total distributions for length and breadth respectively. The table supplies in a compact and readily available form the whole of the information supplied by this collection respecting (i) the variation in length, (ii) the variation of breadth, and (iii) the co-variation of length and breadth.

It is not necessary, however, that both or either of the variates should be quantities capable of numerical measurement. For instance, observations upon the colouring of eggs in a nest in relation to the type of environment in which the nest has been placed could equally well be recorded in a two-way table. In such a case the grouping in one direction would be based upon a graded colour-scale and that on the other by a series of environmental classes, such as green plants, speckled shingle, brown sand, &c. In the following table, taken from the same source, the two characters considered are (a) 'Value' of ground-colour of one egg from a nest, and (b) 'Value' of ground-colour of a second egg from the same nest.

The .75's, .5's and .25's among the frequencies arise because in cases of uncertainty in classification a half-frequency was assigned to both, or a quarter to all four of the possible groups. The colour-value classes w_2-w_4 were described with the aid of a coloured plate in the Memoir. (The table has been made symmetrical by entering each pair of eggs twice, first with one egg as 'first egg' and the other as 'second egg' and then in reversed order.) In this table there is seen to be a marked clustering of frequencies along a diagonal; for instance, when the 'first egg' falls in

¹ This and the table on page 294 are taken from a paper in *Biometrika*, vol. xv, pp. 294-345.

class w_6 , in the largest number of cases (101.5) the 'second egg' is also in this class, and the next largest numbers are in the neighbouring classes w_5 (95.5) and w_7 (75.75).

'Value' of ground-colour in first egg.

	w_2	w_3	w_4	w_5	w_6	w_7	w_8	Totals
w_2	3	8	2	1.75	1.5	.75	—	17
w_3	8	44	40	19	6	6	—	123
w_4	2	40	135	68	29.5	12	2	288.5
w_5	1.75	19	68	153	95.25	41	9	387
w_6	1.5	6	29.5	95.25	101.5	75.5	13	322.5
w_7	.75	6	12	41	75.75	126.5	28	290
w_8	—	—	2	9	13	28	30	82
	17	123	288.5	387	322.5	290	82	1510

The mere arrangement therefore in the table brings out the similarity in colour-value between eggs in the same clutch.

With pairs of measurements the same considerations as to class interval should be applied, as with single variates, save that with close associations a finer grouping may be required to make the class interval as small as a quarter of the average standard deviation of the *arrays* (separate rows or columns).

5. SUMMARY OF A TWO-WAY TABLE.

In all cases where two characters are considered the results can be displayed most compactly in a two-way table, and this forms a convenient basis for the calculation required if it is wished to study the relationship between them. Where the data are in the form of numerical measurements, as in the first example, and if they conform to what is termed a Normal Correlation distribution, the contents of the table may be described by five quantities. These, in addition to being useful in themselves, will serve as a statistical summary of the data when the two-way table cannot be presented in full. These are (i) and (ii) the means and (iii) and (iv) the variances of the two marginal distributions, and (v) the 'product-moment coefficient' which is calculated like the variance from the deviations from the means, using the products of the deviations of the two variates (having regard to the positive and negative sign of these deviations) instead of the squares of the deviations of a single variate. From the three latter statistics any of the following may be at once obtained, one or other of which will in almost all cases be of importance in the interpretation of the data. Denoting the two variates by x and y ,

(a) the *regression coefficient of y on x* is the ratio of the product moment coefficient to the variance of x ; here x is regarded as the independent variate, and y as dependent upon it;

(b) the *regression coefficient of x on y* is the ratio of the product moment coefficient to the variance of y ;

(c) the *coefficient of correlation* is the geometric mean of the two regressions, and may be found either from them, or by dividing the product moment by the geometric mean of the two variances, or by the product of the standard deviations. (Section D, 2.)

This method of description becomes inadequate if the material differs markedly from Normal in the form of its distribution; in such cases the two-way distribution table should not be replaced by a summary.

6. MORE THAN TWO VARIATES.

There is no compact form for the complete publication of sets of three or more measurements. When the number of individuals is not too great, these may be set out *seriatim*, each occupying a line of the table. If the number of class combinations is sufficiently small, which can only occur if very broad classes are employed, it may happen that the class combinations and the corresponding frequencies of occurrence can be compactly listed. For storage in a form ready for immediate use, cards are recommended, each card representing an individual with its numerical measures

entered in corresponding positions on the different cards. A key card should always be prepared giving the significance and units of the several entries on the individual cards.

An incomplete but valuable record of a large number of individuals measured in more than two characters is provided by the preparation of every possible two-way table. Thus with seven variates, twenty-one tables will specify the simultaneous distribution of the samples for every pair of variates. Such a record, though incomplete (because it does not specify which values of all seven characters were associated together in an individual, but only considers them in pairs), will yet provide a basis for all calculations ordinarily conducted.

7. GRAPHIC METHODS.

Diagrams should be freely used in exploring the character of the relationship between two closely related variates. In plotting two sets of values against each other, we may take absolute values, or the reciprocals of the absolute values of one or both, or the logarithms of one or both, and so forth. If a straight graph is obtained by any one of these methods, it suggests a particular type of mathematical relationship, the recognition of which may facilitate the detection of the biological process or mechanism involved.

Diagrams provide no adequate substitute for the tabular presentation of data, or for the critical tests necessary to examine their conformity with the hypotheses they suggest. In the publication of results their purpose is to illustrate and make plain particular facts selected for emphasis by the author, and not to establish such facts. It is not necessary to publish every diagram which has proved useful in studying the data.

C. The Interpretation of Results and Tests of Significance.

1. In carrying out any statistical analysis it is necessary to bear in mind the distinction between the following :—

- (1) The population which has been sampled.
- (2) The true measurements of the sample available.
- (3) The measurements of these individuals as recorded.

Provided that the specification is adequate and that the errors of measurement are small compared with the real biological variation among the individuals of the sample, it may be assumed that (3) provides no adequate description of (2). The problem that remains is to consider what may be inferred legitimately from the measurements (3) regarding the population (1). It needs little experience to realise that the average measure of some character found in a sample, or the percentage of individuals falling into certain groups, may often differ considerably from the values in the population sampled, and further that two samples will themselves often differ considerably from one another. The problem is therefore to obtain criteria which will enable a judgment to be formed as to whether the variation in a sample is of statistical significance (see Section D, 3-8); or is not more than might be expected to arise from the chance fluctuations of random sampling.

By mathematical analysis it has been found¹ possible to determine the variation due to random sampling of some of the most important descriptive measures or statistics, such as the mean or the standard deviation of a series of observations. A definite measure of probability can therefore be assigned to the occurrence of a particular value of the statistic in a random sample. In general, the procedure is to calculate the ratio of (a); the difference between the statistic and the quantitative character of the population of which it is the estimate or between the corresponding statistics in two samples, to (b), the Standard Error or an estimate of the Standard Error of that difference, and then to obtain the probability from the appropriate table.

The nature of the problem can be indicated most readily by considering two typical examples.

(1) Suppose there to be a population of individuals whose frequency distribution for measurements of a single character is Normal (Section D, No. 4); and that the mean measurement is known to be 22.56 cm. while the standard deviation is 1.54 cm. Then it is possible to state by reference to the appropriate table that only in about two cases out of one thousand should we expect to find a mean of 23.56 cm. or more in a random sample of twenty individuals. Or supposing that the only available

information to be contained in the sample of twenty, with mean of 23.56 cm. and a standard deviation of 1.44 cm. by the use of the appropriate probability table, we can assign a measure of probability of 7 in 1000 for the mean in the population sampled lying outside the range 22.56 cm. to 24.56 cm. (Section D, No. 5b). It follows that, in whichever way the problem is presented, one is justified in concluding that it is most unlikely that the difference between the sample mean (23.56) and the population mean (22.56) can be due to the chance fluctuation of sampling. It is therefore what is termed a significant difference, the cause of which must be sought elsewhere.

(2) Another type of illustration is as follows:—

Suppose that in a Mendelian experiment there are theoretical reasons for expecting ratios of 2 : 1 : 1 in three frequency groups. In a sample of forty the following frequencies are observed : 22, 7, 11. There it is possible to say that a divergence from the 'expected' frequencies of 20, 10, 10 as great or greater than that observed will occur in the long run on fifty-five random samples out of one hundred, or in other words that the divergence is not at all exceptional (Section D, No. 8).

2. THE DISADVANTAGE OF SMALL SAMPLES.

In both the examples that have been given, the samples contained only a small number of observations. If the distribution of the character or characters in the population is known it is possible to obtain a measure of the probability of drawing a given sample, however small that sample may be. But when the sample only is known, the nature of the population can be inferred with far less precision from small than from large samples. The difficulties in interpretation to which this may lead can again be illustrated by the previous examples.

(1) Suppose that in addition to the sample of twenty observations with mean of 23.56 cm. and standard deviation of 1.54 cm., there is a second sample of twenty-five with mean 23.14 cm. and standard deviation 1.61 cm. Then in neither case is it possible to estimate the mean of the population sampled with sufficient precision to conclude that the two samples have been drawn from different populations. The position may be put into exact terms by stating that on the evidence available a difference, one way or the other, between the means as great or greater than the observed 0.42 cm. would occur in thirty-seven cases out of one hundred in the random drawings of two samples from the same population.

If, however, the samples had been each ten times as large, viz. 200 and 250, it would have been possible to obtain a more precise estimate of the populations sampled, and to infer that they had almost certainly different means. This can be expressed by saying that for these larger samples a difference in means of 0.42 cm. or more would be expected to be found in only five cases out of one thousand (Section D, No. 6).

(2) If two possible hypotheses existed as to the Mendelian ratios, viz. either 2 : 1 : 1 or 9 : 3 : 4, the evidence provided by the sample figures 22, 7, 11 would be quite inadequate to distinguish between them. It has been seen that the odds are 55 to 45 in favour of obtaining so great a divergence from the expected numbers on the first hypothesis, and for the second hypothesis the corresponding odds are 925 to 75 in favour. These figures would not justify the acceptance of one hypothesis rather than the other, for the observations are not improbable on either hypothesis.

If, however, the sample had been of 400 and the group frequencies 220, 70, and 110, it is found that samples with as or more divergent frequencies would only occur:

- (a) in 25 cases in 10,000 if hypothesis 2 : 1 : 1 were true;
- (b) in 49 cases in 100 if hypothesis 9 : 3 : 4 were true.

It follows that now the evidence is sufficient to show that the first hypothesis is quite improbable, while the second is still in reasonable accordance with the facts (Section D, No. 8).

The statistical methods available thus allow one to test the validity of various hypotheses in relation both to the nature and to the extent of the data presented. An increase in the number of observations will usually increase the precision of all tests, and may justify conclusions which would otherwise be doubtful. The size of the sample is not, however, always a mere matter of the number of individuals measured. Each unit may be a district, a season, or a complete and lengthy experiment, and for such cases the more exact methods appropriate for small samples will be particularly necessary.

D. Notes on Methods and References.

The greater part of the procedure and methods of analysis indicated below was first given in memoirs which appeared in journals such as *The Philosophical Transactions of the Royal Society*, *The Philosophical Magazine*, *Biometrika*, *The Journal of the Royal Statistical Society*, *Metron*, &c. The fullest collected information is probably contained in the following books, for which detailed page references are given below :—

- (A) A. L. Bowley. 'The Elements of Statistics.' King & Son, London. 1920.
 (B) R. A. Fisher. 'Statistical Methods for Research Workers.' Oliver & Boyd, Edinburgh. 1925.
 (C) T. L. Kelley. 'Statistical Method.' Macmillan, New York. 1923.
 (D) G. U. Yule. 'An Introduction to the Theory of Statistics.' Griffin & Co., London. 1927.

(1) Computation of the Arithmetic Mean, Variance and Standard Deviation.

- (A) pp. 251–255. (B) pp. 48–54. (C) pp. 45–48 ; 77–82.
 (D) pp. 108–113 ; 134–141.

(2) Definition and Computation of the Product Moment, Coefficient of Correlation, and Regression Coefficients.

- (A) pp. 350–355 ; 380–383. (B) pp. 114–125 for regression.
 pp. 146–150 for correlation.
 (C) pp. 161–164. (D) pp. 157–188.

(3) The Standard Error and the Probable Error.

The standard error of a descriptive constant or statistic measures the amount of variability to be expected between the values of that quantity found in different samples of the same size drawn at random from the same material. If σ^2 represent the variance in the population, then σ/\sqrt{N} is the standard error of the arithmetic mean for samples of N individuals. Since in the study of natural variation the variance of the population is unknown, we must use instead the variance as estimated from a sample or group of samples, taking care to employ methods which made due allowance for the sampling errors so introduced.

Owing to the fact that if the distribution of a variate be Normal, 50 per cent. of the observations will lie within the range taken from $\cdot6745 \times$ standard deviation below to a corresponding distance above the mean; this multiple of the standard deviation has been termed the Probable Error. Thus $\pm \cdot6745 \sigma/\sqrt{N}$ is termed the probable error of a mean, by which it is implied that the means in samples of N will as often fall inside as outside limits greater and less than the population mean by $\cdot6745 \frac{\sigma}{\sqrt{N}}$. As it is always necessary to find σ or an estimate of σ before the probable error can be calculated, it is always simpler, and more conformable to modern practice, to measure variation by the standard error rather than the probable error.

(4) Tests for Normality.

The distributions given above of the length of Cuckoo's egg and the length and breadth of Tern's egg may be taken as roughly representing the Normal form. This is typified by a central concentration about the mean and a symmetrical tailing off of the frequency for positive or negative deviations, in accordance with a definite mathematical law.

In dealing with samples containing only a few observations, it is only possible to detect wide deviations from the normal form. The test, which is sensitiv only for large samples, involves the calculation of the third and higher moments followed by a comparison of the values obtained from the sample with those to be expected from a normal distribution having the same variance.

- (B) pp. 54–56 or *Phil. Trans.* vol. 198A, 1902, p. 278.

(5) The Significance of a Mean.

(a) Population variance known, or estimated from a large sample.

The test consists in entering the tables of the Normal Probability Function with the ratio of (a), the deviation of the sample mean from the population mean, to (b), the standard error of the mean.

(A) pp. 415-416. (B) pp. 101-103. (C) pp. 82-83. (D) pp. 344-345.

Tables. 'Tables for Statisticians and Biometricians,' Cambridge University Press. Table II.

(B) Table I. (C) Appendix C.

(b) Sample variance only known.

Here the ratio of (i) the deviation of the sample mean from the population mean to (ii) the *estimated* standard error of the mean is taken, and the tables of the 't'-distribution are used.

For large samples this test becomes the same as (a) for all practical purposes.

(B) pp. 106-108.

Tables: (B) Table IV. *Metron*, vol. v, 3, 1925.

(6) The Significance of the Difference between the Means of Two Samples.

The procedure is to enter the appropriate probability tables with the ratio of the difference between the means to the standard error, or estimated standard error, of that difference.

(a) Test applicable in the case of large samples from two populations in which the variance may differ.

(B) pp. 103-105. (D) pp. 345-346. Tables as for 5 (a).

(b) Test, sensitive for difference between the means, as to whether two samples can be regarded as drawn from the same population, accurate for small samples.

(B) pp. 109-113. Tables as for 5 (b).

(7) The Significance of the Difference between the Variance of Two Samples.

Test whether two samples can be regarded as drawn from populations of equal variance.

(B) pp. 192-200. Table VI., p. 210.

(8) The χ^2 Test for Goodness of Fit.

(a) Comparison of the observed frequencies with those expected theoretically in the corresponding groups or classes.

(A) pp. 426-433. (B) pp. 77-84. (C) pp. 370-387.

Tables. 'Tables for Statisticians and Biometricians,' Table XII.

(B) Table III.

(b) Analogous test of agreement between two or more observed frequency series.

(B) pp. 94-95. *Biometrika*, vol. viii, pp. 250-254.

Tables as for 8 (a).

Geography Teaching.—*Report of Committee* (Prof. T. P. NUNN, *Chairman*; Mr. W. H. BARKER, *Secretary*; Mr. L. BROOKS, Prof. H. J. FLEURE, Mr. O. J. R. HOWARTH, Mr. J. MCFARLANE, Sir H. J. MACKINDER, Prof. J. L. MYRES, Dr. MARION NEWBIGIN, Mr. A. G. OGILVIE, Mr. A. STEVENS, and Prof. J. F. UNSTEAD, *from Section E*; Mr. D. BERRIDGE, Mr. C. E. BROWNE, Sir R. GREGORY, Mr. E. R. THOMAS, Miss O. WRIGHT, *from Section L*) appointed to formulate suggestions for a syllabus for the teaching of Geography both to Matriculation Standard and in Advanced Courses; to report upon the present position of the geographical training of teachers, and to make recommendations thereon; and to report, as occasion arises, to Council through the Organising Committee of Section E, upon the practical working of Regulations issued by the Board of Education and by the Scottish Education Department affecting the position of Geography in Training Colleges and Secondary Schools.

THE Report consists primarily of a statement prepared by the Scottish members of the Committee on the position of geography in the schools of Scotland. The syllabuses and regulations governing the subject in England remain substantially as given in a previous report. The Oxford and Cambridge Schools Examination Board has the whole question of the status of geography under consideration.

In the Oxford Local Examinations the syllabus in the School Certificate Examination of 1927 differs from the corresponding syllabus for 1926 only in one important particular, viz.: in the omission of common Map Projections. The Delegates have come to the conclusion as a result of the 1926 and previous Examinations that it is inadvisable to expect a knowledge of Map Projections from candidates of about sixteen years of age. The Delegates have also endeavoured, while giving adequate choice to all candidates, to limit the range of the Regional Geography. Examiners and many teachers had come to the conclusion that some limitation was essential. For 1927 and future years the Higher School Certificate syllabus has been enlarged by the inclusion of a practical paper in response to a recommendation received from a number of geographers and teachers of geography in schools.

In the Cambridge Local Examinations no change is contemplated in Geography Syllabus in the School Certificate Examinations; in the Higher School Certificate Examination the Syndicate have decided, on the recommendation of the investigators, to introduce a new paper on the geography of France and Germany, which may be taken as a subsidiary subject. A list of books will be printed for the guidance of teacher and candidates, and some of these books will be in French and German. It is thought that such a subsidiary subject will appeal to Group II candidates taking French or German, and possibly also to candidates taking History.

The University of Durham School Examinations Board have made certain modifications in the Syllabus, the subject counting in strict parity with the other subjects of Group C (Science and Mathematics).

The Report of the Scottish members is attached.

Report by Dr. M. I. Newbiggin and Messrs. J. McFarlane, A. G. Ogilvie, and A. Stevens, Scottish Members of the Committee.

Leeds, September 1927.

The Scottish members of the Committee wish to report as follows upon the present position of Geography as a subject of higher study in Scottish schools.

Geography was recognised in the school curriculum by the Scottish Education Department as a subject for the Higher Grade Leaving Certificate in 1914. New regulations were promulgated in 1924, retaining the subject, but resulting in the discouragement of its study.

In Scottish schools the leaving certificate (Group Leaving Certificate) is awarded by the Scottish Education Department as evidence of the satisfactory completion of a 'Secondary Course.' The award is made on the basis of teachers' estimates checked by official examinations, and the certificate covers a number of subjects. The

Secondary Course extends over five or six years from the 'Qualifying Stage,' which is generally reached at the age of twelve or thirteen years. Subjects may be professed on the 'higher standard' or on the 'lower.' The higher standard may be defined as a reasonable standard of attainment in a subject which has been studied continuously throughout the secondary course for about four hours (or five periods each nominally of three-quarters of an hour) per week, and the lower as a similar standard for three years' study, or for a shorter weekly allowance of time. Before 1924, passes on the higher standard were required in three subjects and a pass on the lower standard in one, as the minimum for the issue of the certificate. The choice of subjects was limited and the higher subjects commonly offered were English, a foreign language (classical or modern), mathematics or science. Apart from the paper on Geography which was included under the subject of Lower English as Paper III, Geography on the higher standard could be professed only as an additional subject.

Two important alterations were made in the regulations of 1924. The first was the abolition of the Intermediate Certificate, which was a group certificate on the lower standard, and for which some geography was obligatory. The subject is still obligatory for the first three years, but there is now no official written examination at the end of that period. As a result of the demand for time devoted to those subjects which have a value from the point of view of a school anxious to obtain leaving certificates, it has actually disappeared beyond the third year's curriculum in many secondary schools.

The second alteration of the 1924 regulations is the marshalling of the subjects of a secondary course in four groups. Group II offers a choice between mathematics and science. Science is defined as 'any approved combination of physics, chemistry, botany, zoology, geology, geography.' Since the typical approved combination is physics and chemistry, it may be assumed, as Circular 30 indicates, that the members of a combination are normally two in number.

Prior to 1924, the status of geography in Scottish schools was that of a full individual subject on the higher standard, although the fact of its being regarded as an additional subject prevented it being taken by many candidates. A maximum of 200 candidates can never have been reached in any one year. As the total number of candidates for the leaving certificate is in the neighbourhood of 4,000, less than 5 per cent. offered higher geography. The last candidates under the old regulations were examined in the present year.

While, however, under these regulations the number of candidates taking higher geography was small, the fact that lower-grade geography formed a part of the compulsory subject of English meant that all candidates taking Lower English were required to display at least an elementary knowledge of the subject.

Under the new regulations geography, with at least one other science subject, is alternative to mathematics. Together with another science it ranks as co-ordinate with English, a foreign language, art, music, or domestic science, and can be offered either on the lower or the higher grade. It has, therefore, the status of a half-subject only, with a correspondingly restricted amount of time for its study. In theory geography may be offered in conjunction with physics, botany or geology; but for reasons indicated below such combinations are unlikely in practice.

It is certain that the number of schools and of candidates offering higher geography has greatly declined in the last two years.

In most of the secondary schools physics is taught in conjunction with chemistry. There is very little provision for the teaching of botany, and next to none for geology. It has been suggested that botany and geography form a likely combination in girls' schools. In Scotland, however, girls' schools are comparatively rare; mixed schools constitute the great majority. Moreover, it is illogical to assume that geography is a subject of special interest and value to girls, and it is absurd to regard it as of minor importance for boys. On the contrary, we believe that it is extremely desirable from various points of view that boys should be encouraged to carry the subject on to the end of their school course. This they cannot do, on account of the exacting demands on their time, unless they offer the subject for the leaving certificate. Further, the Sub-Committee feel that geography suffers from this grouping in another way. A course must be an *approved* course, and the approval is presumably in the hands of inspectors whose university training has not included geography, and whose sympathies consequently tend to favour other science.

The position of geography in the school curriculum is directly affected by the

official interpretation of the regulations of the Scottish Universities Entrance Board due to become effective in February 1927. This Board accepts the group leaving certificate as exempting from an entrance examination, provided, *inter alia*, it includes (but not necessarily on the higher standard) a pass in mathematics or an 'approved' science. The regulations, however, exert a distinct preference for the selection of mathematics or a classical language on the higher standard in the leaving certificate. Further bias against geography is introduced by an official note on the regulations, precluding the recognition of a higher pass in science where the combination does not include physics (studied continuously throughout the whole science course); and again by the special regulations where, in the alternative examination conducted by the Board the choice in Group II is restricted to mathematics and *physical science*, defined as physics and chemistry. In illustration of the effects of these regulations, it may be mentioned that the number of candidates at the open bursary competition at the University of Glasgow who have taken geography this year has fallen from 50-60 (in recent years) to 29.

The feeling of the Scottish members of the Committee is that, as a medium of general education and as a contribution to mental equipment, geography, properly taught, is entitled to hold in the school curriculum a position inferior to no other subject, save perhaps English, and that it ought to be regarded in the examination as equivalent to mathematics or to the science combination. It is impossible to judge at present of the likelihood of such a view ultimately finding recognition and adoption in official quarters. It has been claimed that under the new regulations the position of geography has in general not been lowered, but rather, in certain respects, improved. The official attitude to the subject claims to be favourable. Nevertheless, whether on account of limitations of school time, misinterpretation of regulations by officials, or the attitude of the Scottish Universities Entrance Board, the effects of adverse influences on the study of geography in the schools are clearly in evidence.

The Sub-Committee, therefore, conclude that the present position of geography in Scottish schools is highly unsatisfactory, and there is evidence that these are much behind English schools, both as to the standard attained and as to the number of pupils carrying the subject beyond a very elementary stage. There appear to be about 35,000 candidates sitting annually in geography for school certificates in England and Wales; while in Scotland in recent years there have been less than 200 candidates in geography for the leaving certificate. In view of the importance of the subject as affording an introduction to scientific method and logical thought, the Sub-Committee regard this as a disastrous state of affairs. Moreover, geography, along with history, offers the only means whereby pupils can be given that framework of precise facts which must underlie sound judgments of the national and international problems that confront the citizen in the complex modern world.



Derbyshire Caves.—*Interim Report of Committee* (Sir W. BOYD DAWKINS, *Chairman*; Mr. G. A. GARFITT, *Secretary*; Mr. LESLIE ARMSTRONG, Mr. M. BURKITT, Mr. E. N. FALLAIZE, Dr. R. V. FAVELL, Miss D. A. E. GARROD, Mr. WILFRID JACKSON, Dr. R. R. MARETT, Mr. I. S. PALMER, Mr. H. J. E. PEAKE) *appointed to co-operate with a Committee of the Royal Anthropological Institute in the exploration of Caves in the Derbyshire District.*

DURING the current year the work at Creswell Crags has been steadily advanced by Mr. Armstrong, a re-examination of Langwith Cave has been commenced by Miss D. A. E. Garrod, and of Ravencliffe Cave by Mr. W. Storrs Fox. In addition an important series of masked caves have been located in Lathkill Dale, apparently containing Pleistocene levels, one of which has been examined by Major T. Harris.

Reports upon these excavations are as follows:—

Creswell.

Mr. Leslie Armstrong reports that during the current year work has steadily progressed in the Pin Hole Cave, and a further area of 24 superficial feet of the Mother Grundy's Parlour rock shelter has been carefully examined. The latter has yielded

a few further implements of similar type to those already published, and evidence confirming the distribution of fauna observed in the excavations of 1924 and already published.

Excavations in the Pin Hole have now reached a point 60 ft. from the entrance. The narrow passage connecting the outer and inner chamber has been completed and work is in progress on the first section of the inner chamber. The deposits of cave-earth in the length examined since July 1926 totalled an average depth of 14 ft. The sections were dug to an average depth of 15 ft. 6 in., terminating in a narrow fissure. The lowest 18 in. was composed of red sand, introduced by water and sterile of animal or human relics. The observations in each section have confirmed those made in the sections previously examined.

The Upper Cave Earth, an average depth of 6 ft. 6 in., was sealed partly by breccia and partly by stalagmite, broken through and disturbed in places to a depth of 1 ft. 6 in. along the eastern wall. Traces of human occupation were constant throughout the deposit and included definite hearths at several points, artefacts of flint, bone and ivory, and also numerous animal bones burnt and split, including several of Rhinoceros. Implements of flint have not been plentiful, but those recovered are of fine workmanship and include Aurignacian and Proto-Solutrean forms.

Five small fragments of worked ivory found appear to be portions of a javelin, of the classic Magdalenian type discovered in 1924. Two of these fragments form parts of the same implement and have been united; a third bears a similar engraved pattern to that upon the 1924 example and confirms the nature of the object and the fact that the upper level of the Upper Cave Earth is contemporary in time with the Magdalenian period of France. Quartzite implements of Upper Mousterian type occur sparingly at the junction of the Upper and Lower Cave Earth. The Lower Cave Earth includes two definite implementiferous zones, exclusive of the Upper Mousterian layer which surmounts it. These zones are each separated by a stratum of fallen blocks of large size associated with a cold fauna. The two layers of blocks have been constant throughout the whole portion of the cave examined and are believed to be indicative of periods of intense cold. No artefacts have occurred in either of them. The lowest stratum of blocks was in places cemented by breccia and stalagmite.

The implements consist of hand axes and trimmed flakes of quartzite and also split bones and pieces of reindeer antler showing signs of use by man.

The fauna recovered includes bones, teeth and antler of Irish Elk in addition to the fauna already recorded, also skulls of several birds and fragments of four large eggs, one of which is almost a complete specimen and resembles the egg of a goose.

Ravencliff Cave.

A re-examination of this cave, situated in Cressbrook Dale, was undertaken in May by Mr. W. Storrs Fox and is still in progress.

An undisturbed Pleistocene level has been proved and bones of Rhinoceros Tichorinus and Bear recovered, also cut and split bones indicative of man's presence.

Upon the platform outside the cave two flints were found, Upper Palaeolithic in facies and associated with Rhinoceros. A layer of stalagmite three to four feet thick is now in course of removal.

Lathkill Dale.

Early in the year a masked cave was discovered here by Major Harris of Ashford, and, acting on Mr. Armstrong's advice and under his general supervision, Major Harris has carefully excavated it. Cave-earth in two layers was discovered. The lower, a stiff red loamy clay, contained a Pleistocene fauna and flakes of flint bearing signs of use. No typical implements have been recovered, but Prof. the Abbé Breuil, who inspected the cave in May, considers them to be Upper Palaeolithic in facies. Their horizon is at present uncertain.

The Upper Cave Earth yielded well-worked implements of flint, Neolithic or Bronze Age in date. The crags in the vicinity of this cave were reconnoitred by Prof. Breuil and Mr. Armstrong, and further masked caves located, an examination of which will be undertaken in the near future.

As Palaeolithic remains have not previously been recorded from this area of Derbyshire, the results of the work in Lathkill Dale and Cressbrook Dale are important.

The work on the above caves has been assisted by a grant made by the Trustees of the Percy Sladen Memorial Fund.

Report of Excavations at Langwith Cave, Derbyshire:

April 11-27, 1927.

Work was carried out in Langwith Cave for three weeks in April 1927. I first excavated a chamber to the north of the main chamber dug out by Mr. Mullins, and found the following sequence of deposits:—

1. Black loamy earth containing modern bones, about 60 cm. thick.
2. Stiff sandy clay (cave-earth), reddish-yellow in colour, 80 cm.—1 metre thick. This was excavated in three levels, each about 30 cm. thick, and yielded Pleistocene bones, including *Rhinoceros Tichorhinus*, reindeer and hyena.

After the excavation of this subsidiary chamber I began to dig away a bank of cave-earth left in place against the N.W. wall of the main chamber, and uncovered a low archway leading into a part of the cave hitherto unknown. Inside this arch only the cave-earth was present, and it was covered in places by a thin plate of stalagmite. Bones were very abundant, and included reindeer and hyena. It was not possible to finish the excavation of this chamber, which seems to extend a good way in a N.W. direction.

Fragments of flint were found in the upper levels of the cave-earth in both parts of the cave. I obtained in all six finished implements of Upper Aurignacian type, and eight flakes.

Miss D. M. Bate will study the animal bones, and the final disposition of the material is in the hands of the Derbyshire Caves Committee of the British Association.

D. A. E. GARROD.

Kent's Cavern, Torquay.—*Report of Committee appointed to co-operate with the Torquay Natural History Society in investigating Kent's Cavern.* (Sir A. KEITH, *Chairman*; Prof. J. L. MYRES, *Secretary*; Mr. G. A. GARFITT, Prof. W. J. SOLLAS, Mr. MARK L. SYKES.)

The Committee submits the following report from the excavators, and desires to express its grateful acknowledgment of their work, and of the facilities given by the Torquay Natural History Society. The Committee asks to be reappointed, with the balance in hand, and renewal of leave to collect funds from other sources as required.

Second Report on the Excavations in Kent's Cavern, Torquay:

October 1926—June 1927.

The second season's campaign began in October 1926, and has continued to the end of June 1927. Work has been concentrated upon an area 16ft. by 10ft. at the east end of the trench dug last season, which has been extended to a length of 51 ft., while an additional deposit over 13 ft. thick has been removed and sorted.

Remains of all the members of the usual Cave-fauna discovered last season have continued to turn up, and to these must now be added the Mammoth and Man. Three teeth of the latter found at a depth of 10 ft. 6 in. below the Upper or Granular Stalagmite (A) (datum line) have been submitted to Sir Arthur Keith, F.R.S., for examination and are stated by him to be of Upper Palaeolithic age, and to be not distinguishable from the teeth found by Pengelly in 1866 in the lower portion of the Upper Stalagmite (A).

During the course of the season's labours the geological conditions under which this thick deposit of cave-earth was laid down have been clearly revealed. At the E. end of the trench the walls of the cave approach each other to form a bottle-neck between the Vestibule and the N.E. Gallery. A Section 12 ft. deep visible at this point is filled from top to base with a deposit composed of angular, rounded and rolled limestones in a matrix of cave-earth, either loose or in places cemented lightly by stalagmite, and evidently representing a 'jam' of material in the bottle-neck.

At a point 8 ft. below datum line this deposit is interrupted by a Stalagmite floor (B), but reappears beneath and continues to the base of the excavation, at this point 16 ft. below datum. Both above and below the stalagmite floor slabs of broken stalagmite occur here and there in the cave-earth, and it is clear that at least one more

floor of this material had once existed, only to be broken up and dispersed. But it has not been possible to trace its original position more exactly.

The lower Stalagmite floor (B) is itself discontinuous, having been in parts broken up and its place taken by a firmly cemented breccia of angular limestones of no great size, presumably the agents of destruction.

At 16 ft. west of the bottle-neck, at a point where the Stalagmite floor (B) thins out from nearly 1 ft. thick to no more than 2 in., a mass of heavy rock had fallen upon and destroyed it, and then had itself been cemented into a strong breccia by the continued formation of stalagmite. To the base of this breccia slabs of the broken stalagmite adhere. This heavy breccia is known to continue westwards for another 10 ft. at least, and over this distance its lower surface appears as an arch, covering an empty space, from which all deposits have been denuded and whose floor appears to be the natural rock of the cave, descending steeply into a narrow fissure.

But beneath the Stalagmite floor (B), where still intact, and beneath the breccia of smaller stones which sometimes takes its place, and from the bottle-neck to a point 16 ft. to the west, there is no empty space, but the deposit of cave-earth continues downwards. It is in this area that the cave-earth has been excavated to a total depth of over 20 ft. below datum line.

The geological sequence of events appears to have been as follows :—

1. Deposition of 12 ft. (or more) of cave-earth, with large fallen stones.
2. Formation of a Stalagmite floor (B).
3. Partial destruction of this floor by a fall of rock.
4. Continued formation of stalagmite, brecciating the fallen material.
5. Torrential flooding from the direction of the N.E. Gallery, penetrating beneath the Stalagmite floor (B) at the point of fracture, and ravining and carrying away the cave-earth from beneath the heavy breccia.
6. Resumption of the deposit of cave-earth.
7. Formation of a second stalagmite floor.
8. Destruction and dispersal of that by further floods.
9. Resumed deposition of cave-earth.
10. Occupation of the chamber by man with the remains of hearths (the Black Band) in the final Magdalenian period.
11. Formation of a third and final Stalagmite floor (A).

The flint implements discovered this season have been few in number. They do not differ from those found last year. We have been slowly approaching the conclusion that the industry represented may be Upper Aurignacian. This view is based mainly on the high proportion of simple blades. It has since been supported by very high authority. But the position is difficult. Other experts have pronounced the same series to be of Middle Aurignacian provenance. Evidently the series is not very typical—a remark which may perhaps apply equally to a small series of scrapers and a bone pin found in 1866 at 4 ft. below datum, which has also been referred to the Middle Aurignacian. On the whole there does not appear to be sufficient material of good type for satisfactory classification, and it may be wise to regard the implements as Aurignacian without further qualification as to phase until further work may produce datable examples.

It is evident that the geological conditions under which the deposits were formed render highly possible a mixture of artefacts from more than one period. In the course of the season's work only one or two charred bones have come to light. We have not discovered the hearth from which it was derived. The high proportion of broken or frustrated blades suggests the debris of a workshop. But the position of this workshop is as yet unknown. The most prolific level (7 ft. 3 in.) has yielded no more than one flint specimen of any kind to 6 square feet of superficial area—hardly sufficient to denote a Palaeolithic floor of occupation. Further exploration in the direction from which the deposits entered the cavern may result in the finding of more typical flints. But the abundance of teeth and bones of hyena at nearly every level, and of bones gnawed by that animal, suggests that human occupation of this part of the cave must have been temporary and occasional at best.

One may tentatively suggest that man may have been a summer visitor to the neighbourhood, camping out on the plateau above the cave, quite possibly in more than one phase of Aurignacian times, and that floods originating from the melting of heavy snows, on two occasions at least, ravined his deserted camping grounds, sweeping into the cavern, through swallow holes, the artefacts of different periods and depositing them side by side, or even in apparently inverse chronological order.

TABLE OF FINDS FROM EXCAVATIONS IN KENT'S CAVERN, TORQUAY.

Fauna.	G.S. B.B.		Cave Earth with Stones and Stalagmite-slabs.								Cave Earth with fallen rock.										
	1'	2'	3'	4'	5'	6'	7'	8'	9'	10'	11'	12'	13'	14'	15'	16'	17'	18'	19'	20'	21'
<i>Levels in feet below B.B.</i>									9'												
Horse	×	×	×	×	×	×	×	×	×	×	×	×	×	×	×	×	×	×	×	×	×
Bos and Bison	×	×	×	×	×	×	×	×	×	×	×	×	×	×	×	×	×	×	×	×	×
Deer	×	×	×	×	×	×	×	×	×	×	×	×	×	×	×	×	×	×	×	×	×
C. Megaceros	×	×	×	×	×	×	×	×	×	×	×	×	×	×	×	×	×	×	×	×	×
Reindeer	×	×	×	×	×	×	×	×	×	×	×	×	×	×	×	×	×	×	×	×	×
Bear sp. (U. arctos?)	×	×	×	×	×	×	×	×	×	×	×	×	×	×	×	×	×	×	×	×	×
Rhinoceros Tichorhinus	×	×	×	×	×	×	×	×	×	×	×	×	×	×	×	×	×	×	×	×	×
Elephas primigenius	×	×	×	×	×	×	×	×	×	×	×	×	×	×	×	×	×	×	×	×	×
Wolf	×	×	×	×	×	×	×	×	×	×	×	×	×	×	×	×	×	×	×	×	×
Fox	×	×	×	×	×	×	×	×	×	×	×	×	×	×	×	×	×	×	×	×	×
Hyena	×	×	×	×	×	×	×	×	×	×	×	×	×	×	×	×	×	×	×	×	×
Badger	×	×	×	×	×	×	×	×	×	×	×	×	×	×	×	×	×	×	×	×	×
Cave Lion	×	×	×	×	×	×	×	×	×	×	×	×	×	×	×	×	×	×	×	×	×
Eagle	×	×	×	×	×	×	×	×	×	×	×	×	×	×	×	×	×	×	×	×	×
Homo sapiens	×	×	×	×	×	×	×	×	×	×	×	×	×	×	×	×	×	×	×	×	×
Flints : Blades (A)	×	×	×	×	×	×	×	×	×	×	×	×	×	×	×	×	×	×	×	×	×
Scrappers (B)	×	×	×	×	×	×	×	×	×	×	×	×	×	×	×	×	×	×	×	×	×
Harpoons	×	×	×	×	×	×	×	×	×	×	×	×	×	×	×	×	×	×	×	×	×
1865—1881										1926 Feb.-June.											
Penggelly's Excavations throughout the Cavern.										Excavations in Vestibule only.											
1926 Oct.—1927 June.										1926 Oct.—1927 June.											

G.S. = Granular Stalagmite. B.B. = Black Band. Stal. = Lower Stalagmite 2 ft.—1 ft. thick.

Prof. W. J. Sollas, F.R.S., has kindly informed us that, according to a recent re-classification by the Abbé Breuil, the two uniserial harpoons found in 1866 in the first foot level of the cave-earth and in the Black Band (which is incorporated in that level) belong to the final phase of the Magdalenian and are Maglemosian in type. An interesting light is thus thrown on that obscure period which lies at the end of the Palaeolithic Age and precedes the true Neolithic period. One of these harpoons closely resembles the Maglemosian specimen from Bethune. The other and stratigraphically slightly later specimen shows some approach towards the fine, slender examples found in Holderness. But the Devonshire specimens were associated with remains of a late Pleistocene cave-fauna and must lie at the beginning of a series which terminates at Holderness and at various localities on the Baltic.

At the same level in Kent's Cavern we have a flint industry showing Late Aurignacian survivals with an occasional tendency to geometric forms. This tendency is more definitely seen at Aveline's Hole in the Mendips, where it is associated with a later fauna, and with a harpoon which appears to be on a different line of evolution from that of Maglemose. A link seems to be provided by the earliest known appearance in Britain of a brachycephalic folk, represented by skulls at both sites, and one remembers that still farther north, at Creswell, a brachy skull was found many years ago, apparently at a level where a similar mixture of Late Aurignacian flints and Magdalenian bone and horn industries passed definitely into an Azilio-Tardenoisian microlithic industry. It seems that at the end of the Palaeolithic Age in this country, two new factors appear—a brachycephalic people and a geometric tradition in flint working. Are they related as cause and effect?

We desire to express our thanks to Mr. F. Beynon, whose advice and leading on the geological side has been of great value to us; to Mrs. M. M. Currey, Mr. H. J. Norman, and other friends who have helped in the work, and to the proprietor of the cave and his son, who have assisted us in every way possible. Towards the end of the season we had the pleasure of a visit from Prof. J. L. Myres, who inspected the excavations in our company. Sir Arthur Keith, F.R.S., has kindly reported on the human remains which have come to light, and we owe a debt of gratitude to Prof. W. J. Sollas, F.R.S., for his unfailing patience in dealing with the questionings of inexperience.

It is hoped to reopen the campaign next October.

H. G. DOWIE.

A. H. OGILVIE.

Postscript.

Since writing this report one of us has had the opportunity of seeing the flints from Paviland preserved at Oxford, with the following results: (1) One or two straight scrapers from Kent's Cavern resemble closely similar scrapers from the Middle Aurignacian of Paviland. (2) But the blades from Kent's Cavern, both of the pointed and broad truncated types, are not seen in the Paviland Collection, and, on the contrary, have numerous analogies from the Upper Aurignacian of Aveline's Hole and Gough's Cave. (3) Two well-made end-scrapers are the best implements in our series, but they may be of almost any period of the Upper Palaeolithic. (4) Two or three blades are notched, and one has been referred to the Middle Aurignacian, but the notches seem to us to be probably natural. (5) One end-scrapers with opposed tang approaches the type of the carinated scraper. Another, with straight scraping edge, is apparently identical with one illustrated from the Upper Aurignacian of Aveline's Hole.

On the whole, the general facies does not seem to be Middle Aurignacian, and there is an absence of the careful, regular marginal retouch characteristic of that period.

Prof. W. J. Sollas, F.R.S., has kindly offered to submit the series for classification at the hands of the Abbé Breuil. Any further remarks will naturally await his conclusions.

H. G. DOWIE.

Colour Vision. *Report of Committee* (SIR CHARLES SHERRINGTON, *Chairman*; Prof. H. E. ROAF, *Secretary*; Dr. MARY COLLINS, Dr. F. W. EDRIDGE-GREEN) *appointed to report upon Colour Vision, with particular reference to the classification of Colour-blindness.*

1. Defects of colour vision usually consist of a decrease in the perception of colours, therefore hypochromatism or hypochromatopia is a suitable term for defects in colour vision.

2. In order to classify satisfactorily the defects in colour vision, one must know the actual differences in colour discrimination between normal and hypochromatic individuals.

3. Defects in colour discrimination are not always accompanied by decrease in sensitivity to light. Localised decrease in sensitivity to long wave lengths is not infrequent, a similar decrease in sensitivity limited to short wave lengths is also found, but the statement that there are cases with a localised decrease in sensitivity to intermediate wave lengths is not proved.

4. The terms red blindness, violet blindness, &c., are meaningless, except on the basis of a decrease in sensitivity limited to the corresponding portion of the spectrum.

5. Decrease in sensitivity to light such as is mentioned in paragraph 4 will cause change in colour value of all colours which include those wave lengths to which the individual is less sensitive than the normal, but when there is no decreased sensitivity to light the term confusion should be used. Thus red-yellow-green confusion would describe the usual form of hypochromatism in which there is decreased ability for distinguishing colour differences at the longer wave lengths of the spectrum. It would be preferable to indicate the actual wave lengths at which discrimination is defective, as that would indicate the extent of the defect and not merely the qualitative region of the spectrum involved.

6. The nomenclature at present in use is unsatisfactory, and it is recommended that it be discarded. The descriptions of cases are very defective, as one cannot be certain whether they are based on theory or on examination of the cases. By the loss of one system of the Young-Helmholtz hypothesis dichromatic vision would occur, there being only two colours recognisable in the spectrum. Such a loss is implied in the following terms, which should be abolished.

- (a) Protanopia, or scoterythrous vision, has been used to imply a failure to distinguish between red, yellow and green, with a shortening of the long wave length end of the spectrum.
- (b) Deutanopia, or photerythrous vision, has been used to imply a failure to distinguish between red, yellow and green without any shortening of the spectrum.
- (c) Tritanopia has been used to indicate a failure to distinguish between blue and green, not necessarily accompanied by shortening of the short wave length end of the spectrum.

7. The following method of classification is recommended, as it avoids all theoretical views and allows for variation in degree of the defect.

(a) Any marked decrease in sensitivity to a special region of the spectrum should be specified as blindness; thus red blindness indicates decreased sensitivity to long wave lengths, and if one can state the wave lengths involved the description will be more accurate.

Note to 7 (a).—The length of the spectrum for a normal individual will vary with the intensity and quality of the light used, as well as with the characteristics of the optical system. Therefore the best method of showing the defect is to present a curve showing the increase in threshold to light of the region involved. Any spectral apparatus with a shutter for isolating a narrow region of the spectrum can be used to determine the rise in threshold, if the intensity of the light is varied by an episotister or a photometric wedge. Any shift in the region of maximum intensity would be shown by such a method.

(b) Any failure to discriminate colours should be described as confusion, prefixing the colours confused, e.g. yellow-green confusion. The number of distinct colours which are recognised in the spectrum is a rough measure of the degree of colour discrimination; thus Dr. Edridge-Green classifies those with defective colour discrimination as penta-, tetra-, tri-, di-, and mono- or a-chromats. As in 7 (a), it is preferable to have some quantitative statement of the degree of the defect.

Note to 7 (b).—Both normal and hypochromatic individuals use differences in brightness as an aid to colour discrimination, therefore some method should be used in which comparisons are made of lights of unequal brightness. As normal persons have maxima of discrimination, at wave lengths 5850 A° and 4950 A°, and at the same wave lengths differences in intensity do not cause a change in colour, therefore one method of measurement would be to state the maximum mistakes at these regions. A difference of over 50 A° or a range of over 100 A°, if the difference on each side of a fixed wave length is measured, would indicate defective colour discrimination. (See Roaf, *Quart. J. Exper. Physiol.* 1927, vol. 16, pp. 379-392.) The measurement would correspond to a monochromatic patch as measured by Dr. Edridge-Green, if the difference in brightness between different wave lengths of the same spectrum could be eliminated.

(c) All those persons with dichromic vision—*i.e.* who recognise only two colours in the spectrum—possess a neutral region, the position and extent of which should be determined.

University Course in Experimental Psychology.—*Report of Committee* (Dr. J. DREVER, *Chairman*; Dr. MARY COLLINS, *Secretary*; Mr. F. C. BARTLETT, Mr. R. J. BARTLETT, Prof. C. BURT, Dr. SHEPHERD DAWSON, Prof. A. E. HEATH, Dr. LL. WYNN JONES, Prof. T. H. PEAR) *appointed to consider a first-year course in the above.*

1. It is realised that experimental courses must vary in procedure according to circumstances, such as equipment of laboratory and number of students and nature of the general course of study of the students.

2. The aim of the Committee is to lay down fundamental principles which ought to guide the drawing up of any experimental course.

3. Theoretical psychology and practical psychology should go hand in hand from the beginning.

4. Lectures on experimental topics should be included in the general lectures.

5. Sixty hours' laboratory work should represent a reasonable minimum in a first year's course.

6. The aim of the earlier experiments should be to familiarise the student with the experimental method of approach in psychology, and at the same time emphasis should be laid on the importance of introspection.

7. The employment of the psycho-physical methods should come early in the course.

8. A first year's course should include laboratory work on perception, imagery and association, learning and memory, imagination, the special senses, feeling and reaction time, psycho-physical and statistical methods.

Illumination of Plants.—*Report of Committee* (Prof. W. NEILSON JONES, *Chairman*; Dr. E. M. DELF, *Secretary*; Prof. V. H. BLACKMAN) *appointed to make investigations on the effect of duration and nature of illumination on growth and flowering in Arachis hypogæa and Voandzeia subterranea.* (*Drawn up by the Secretary.*)

EXPERIMENTS were carried out under my direction from July to October, 1926, some at the Royal Gardens, Kew, by Miss K. Ritson, B.Sc., with the permission of the Director, and others at the same time by Miss A. Westbrook, M.Sc., in the greenhouse laboratory of Bedford College, by the courtesy of Prof. Neilson Jones. Additional experiments are now in progress at the Royal Botanic Gardens, Regent's Park.

Seeds of *Arachis* and *Voandzeia* were kindly supplied from West Africa by the Director of Agriculture for the Gambia, and were grown successfully to the flowering stage; *Pelargonium* (hybrids) and other pot plants were also used.

The plants were exposed daily for short time intervals (30 seconds to 15 minutes) to the unscreened light of a Hewittic mercury vapour lamp, at distances varying from 2 to 8 feet. With exposures of 1 minute daily or longer, the modifications of growth and structure were similar, and became progressively more marked with the longer exposures. Exposures of 30 seconds daily in November appeared to give no result

with seedlings of *Trifolium subterraneum*, but subsequently a stronger growth appeared ; a somewhat similar after-effect was also seen in the case of a hybrid *Pelargonium*.

Exposures of 2 minutes daily given to plants of *Voandzeia* receiving natural illumination for only 7 or 5 hours daily have a much more serious effect than when given to a plant receiving a 12-hours' day.

The full report of these experiments will appear in the Proceedings of the Society of Experimental Biologists during the course of the present year.

Educational Training for Overseas Life.—*Report of Committee appointed to consider the Educational Training of Boys and Girls in Secondary Schools for Overseas Life* (Sir JOHN RUSSELL, *Chairman* ; Mr. C. E. BROWNE, *Secretary* ; Major A. G. CHURCH, Mr. T. S. DYMOND, Dr. VARGAS EYRE, Mr. G. H. GARRAD, Rev. Dr. H. B. GRAY, Sir RICHARD GREGORY, Mr. O. H. LATTER, Miss McLEAN, Miss RITA OLDHAM, Mr. G. W. OLIVE, Mr. A. A. SOMERVILLE, Dr. G. K. SUTHERLAND, Mrs. GORDON WILSON).

THE special work undertaken by the committee since the last meeting of the Association, viz., the elaboration of schemes of practical work in schools for garden, field, and laboratory, has not been sufficiently developed for publication this year, but it is hoped to issue an interim report in 1928.

In carrying out this project the committee have had in mind the twofold nature of their objective, viz., the introduction of agricultural studies into the curriculum, not only to help forward those who are destined to pursue an agricultural career on leaving school, but also to benefit boys generally whatever avocation they are likely to adopt later on.

1. Agricultural studies have an educational and cultural value which has been fully proved wherever the work has been carefully planned and systematically established. By their means the teaching of History, of Geography, and of Science becomes vitalised and humanised. Such studies lead to a natural growth of knowledge of the basal facts of life ; they afford an inexhaustible supply of projects from which other subjects of the curriculum may draw their inspiration. Ordinary school occupations, to the young, often present no rational sanctions, they suggest no simple purpose linking them to actual living. Agricultural studies and associated activities succeed in supplying these sanctions, and therefore create the interest which bridges the gap between work in school and the course of life outside.

2. Their economic value is equally clear in affording opportunities for a first-hand acquaintance with ' the chief industry of the world.' They open the eyes of a youth to the possibilities of a career on the land overseas, and they afford him sufficient experience to enable him to decide whether he is fitted or unfitted for such a life. To sum up, by supplying land workers for the Oversea Dominions the schools would be helping, in no small measure, to bring about that distribution of population within the Empire so keenly desired by all economists, not only in the interests of the Oversea Dominions and of Great Britain generally, but equally in the interests of the individual.

In connection with the last-named objective, and as a valuable contribution to their inquiry, the committee have included in this report a paper written by Commissioner D. C. Lamb, of the Salvation Army, ' On the importance to the Empire of the transplantation of boys, with some observations anent (a) the benefit of giving them elementary training in agriculture before they leave the Mother Country, and (b) their settlement and after-care in the King's Oversea Dominions.' Though this paper does not refer to secondary schools, it deals with the adolescent stage in life and describes experiences which supply useful information for the guidance of those concerned with the training of boys of every grade between the ages of fourteen and eighteen years.

Transplantation of Boys Overseas.

By Commissioner DAVID C. LAMB.

The density of the population of England and Wales, 649 persons per square mile, is now the highest in the world.

In June 1921 the peak of unemployment in post-war conditions was reached, the

number of unemployed persons on the live registers of the Labour Exchanges in the United Kingdom being 2,580,429, of whom 102,116 were boys aged 18 and under. In 1926, when the total unemployed reached 1,527,751, the unemployed youth was 43,542. The disastrous effect of unemployment upon adults is a serious matter, but in youth the deterioration aggravated by overcrowding is tragic.

It was to do something to arrest this demoralisation of youth that led to the initiation of General Booth's Scheme for Boys, a scheme which provides for giving boys in the United Kingdom of from fourteen to eighteen years of age some elementary agricultural instruction and training before actually taking them overseas and placing them in situations with farmers.

The value to the Empire of this work cannot be over-estimated since the vast vacant spaces in the King's Oversea Dominions are in themselves a challenge, while the proper distribution of the man-power of the Empire is vital to her safety and well-being. The value of the transplantation of youths, however, is much more than a mere distribution of man-power would indicate. Demoralisation is arrested, and the creative faculty is re-born by the process. It is the spirit of adventure, too, rather than the feeling of social and economic pressure, that inspires youths who go overseas. They fit readily into conditions overseas, and they take with them a breath of the Homeland. Men and women often emigrate because of social and economic pressure, their outlook and enterprise being restricted by these circumstances. Not so a boy emigrant, his youthful enterprise is at bursting-point.

These boys are doubly welcome overseas because they engage themselves in the primary productions and do not disturb—except beneficially—existing economic conditions; at the same time, without much additional capital expenditure, they themselves become producers, and relieve for men's work men who have hitherto been uneconomically engaged in boys' work.

General Lines of the Scheme.—The scheme provides for the selection of boys in 'blind alley' occupations, in odd jobs, or unemployed in the United Kingdom, training them on the Army's Farms at Hadleigh, Essex, and transplanting them overseas. It takes cognisance of the boy's whole needs. It complies with the requirements of the respective Governments; provides for efficient after-care, and covers contingencies not recognised by the Governments. Repatriation when necessary is arranged. Suitable outfits are given to each boy before embarkation, and the boys travel overseas in the care of a conductor. The scheme is carried on without respect to creed or nationality, except that imposed by the Empire Settlement Act, 1922. There is no financial qualification or disqualification in the scheme, general fitness being the test.

Period of Training.—The period of training depends upon a boy's ability. It is also influenced by the fitting in of dates of sailings, etc., but training is never less than six weeks, and may extend to three months. The curriculum is designed for short and long periods of training. A boy taking the shorter course is able to cover all the subjects, and if taking the longer course, would not be going over the same ground again. No attempt is made to specialise, but a boy with 'stock' sense will naturally come closer up to 'stock' questions. Elementary knowledge of simple farm operations is acquired in a short course of training, and as soon as a lad is reasonably advanced he goes overseas. If a longer course were given him he would probably have some things to unlearn. The net result of the training may be said to be that the boy has learned that he knows nothing about the business! Boys are taught how to approach a horse, made familiar with the process of milking a cow, taught to tend sheep and pigs, and generally instructed in the attendant duties.

The Farms and their Equipment.—Hadleigh in Essex lies near Southend-on-Sea, forty miles east of London, on the north bank of the Thames (opposite Sheerness), and from the ruins of the old castle one sees the Thames Estuary with the Nore Lightship in the distance, and the ceaseless arrival and departure of the world's shipping. The Training Farms cover 2,000 acres and carry forty head of milking pedigree cattle (Red Lincolns); 200 pedigree pigs (Middle White Yorks); 600 sheep, etc. Some 300 acres are taken up in orchards and market gardens, and there is a brickfield worked on the estate. The property has been in the Army's occupation since 1891, but it was not until August 1923 that it was devoted largely to the training of boys, although prior to that men, women and boys had been trained for overseas settlement. Since the inception of the Boys' scheme over 3,000 boys have been successfully trained there and settled overseas.

Recruitment and Selection of Boys.—Publicity is given by announcements in the Press, lectures in public halls, in schools, etc., and through the Army's offices and periodicals. On receipt of applications from boys some general information is sent,

and if the replies warrant further enquiry, this is made to schoolmasters, clergymen, employers and others. Before being accepted for training, each boy is seen by a Salvation Army officer, and is passed by the family doctor. The Government Medical Inspection takes place after the boy has been on the Training Colony for a few weeks.

The total number of applications received from boys for the years 1925 and 1926 was 20,624.

The number of boys selected and received for training was 1667.

The actual sailings were 1519.

The boys who sailed represented the following proportions of nationalities or districts :—

English, 59 per cent.	Irish, 11 per cent.
Scots, 25 per cent.	Welsh, 5 per cent.

Trades or occupations were represented in the following proportions :—

Trades (i.e., Fitters, Tinsmiths, Woodworkers, Butchers, Hairdressers)	30 per cent.
Occupations (i.e., Errand Boys, Shop Assistants, Lift Boys, Van Boys)	25 per cent.
Unemployed	45 per cent.

Religious denominations of boys transplanted work out to the following percentages :—

Church of England 40	Nonconformists 23
Presbyterian 20	Salvationists 8
Church of Ireland 4	Roman Catholic 5

The ages of boys who actually sailed may be divided as follows :—

14 to 17 years	42 per cent.
17 to 19 years	55 per cent.
Over 19 years	3 per cent.

Total Costs.

The total cost of the transplantation of a youth is on the average about £60, made up as follows :—

	£	s.	d.
Recruitment and selection : medical fees, etc.	4	0	0
Training : 8 weeks at 30s. per week	12	0	0
Railway travelling to training centre and to port of embarkation	1	10	0
Outfit	6	0	0
Ocean passage, including embarkation and disembarkation expenses, and rail overseas	26	10	0
Reception and after-care, covering a period of three years	10	0	0

Cost of ocean passage varies, and there is also considerable differences in overseas rail costs. Governments (Home and Overseas Dominions) co-operate in meeting or assisting to meet the ocean passages, and in some instances in the other expenses.

The net cost to Army funds is about £10, and towards this the boys themselves are expected to assist when they are at work overseas. Contributions from boys before sailing, on the average, amount to a little over £1 per boy. In this connection it might be noted that while the training of a youth by the Army costs 30s. per week, a young man being trained at one of the Government farms costs 50s. a week, and further, that period of training for a youth is two months as against four months for a young man.

Repayments : a Moral Principle.—Before passing from the question of costs, reference must be made to the question of payments and repayments by the boys. It is a fundamental principle that the beneficiaries of the Army's ministrations—spiritual and social—should, according to their ability, make some contribution towards the cost of the services rendered. All that the Salvation Army asks is that the boy should pay or repay what has been spent of Army funds—which on the average is about £10—so that similar work may be continued for others. This system engenders a spirit of independence; it tends to maintain self-respect; it creates a thought for others and helps us to continue the good work. The scheme limits the period over which repayments can be spread to a maximum of two years. During the first year, clothes, and a fairly liberal amount of pocket money, are a first charge

on the boy's earnings, and in the second year—for as long as may be necessary—half his wages. The repayments are invariably paid off long before the end of the second year.

Cost of a Boy.—The average cost to the country of a boy, in food, clothes, shelter, and education, may be taken at £20–£26 a year, so that a lad between fifteen and sixteen years of age has cost the country approximately, say, £350. Surely it is a good investment then to add this £60 for transplantation, and so guarantee a satisfactory return for the expenditure. By neglecting the boy when he completes his education, he becomes a charge on industry and continues to be a consumer when he ought also to become a producer.

Value of a Boy.—The expenditure upon a boy, together with the cost of his emigration, gives a total cost, approximately, of £400 per boy. The Motherland makes a gift of this potential wealth producer to the Oversea Dominions, and looks for no definite or tangible return for the outlay.

Present v. Future Empire Needs.—Statistical information would suggest that in a comparatively short space of time the heavy fall in the birth-rate during the Great War will affect the supply of juvenile labour in Great Britain. It is estimated that in 1933 the number of juveniles (boys and girls) available for employment will be 400,000 less than the number available to-day, which is estimated to be 2,165,000. It may be safely assumed that 50 per cent. of these figures refer to boys. Even if this be so, it is no reason why boys of the present day, having regard to the past seven years' unemployment and the profound world changes affecting all our industries, should be denied the opportunities awaiting them overseas; further, it is contended that the Empire's present needs should outweigh any problematical view of the future. In view of all the circumstances, it would seem to be good business to set about training tens of thousands, instead of a few hundreds.

Demand for Boys.—To those who may have a doubt that, in the event of training schemes being undertaken on a grand scale, boys would find employment overseas, it may be said that the demand overseas for boys is many more times than the supply, and is likely to continue so, because these young fellows will quickly commence farming on their own account.

Arrangements made before arrival Overseas.—What happens to the boys overseas? On arrival, the conductor of the party introduces them to the officers who have already been advised by letter and cable of the actual numbers travelling. These overseas officers have been enquiring into the suitability of the farmers applying for a boy, and no boy is sent to a situation until some experienced person acting under our instructions has seen the farmer, and is satisfied that the conditions are fair and reasonable, and that suitable house accommodation is provided. Thus the boy is sent without delay to a situation—care being taken not to send two boys off the same ship to adjoining farms. Usually a boy goes a month on trial. If the farmer likes the boy, and the boy likes the farmer, twelve months' agreement is then concluded. This ensures the opportunity to the boy of observing a full year's work on the farm, and prevents any town drift in the winter time.

After-care Safeguards.—The boys' distributing centres are set up in country districts—not in large cities—and the officers keep in touch with the boys by visits and correspondence. During the first six months newspapers or magazines are posted regularly every week to the boy, and if a boy wants to run away he knows where he can be assured of a sympathetic understanding and treatment of the malady of homesickness as well as minor ailments which might prevent his continuing at work, but would not require his admission to a hospital. They are not spoon-fed, but rather taught to be manly and self-reliant.

Re-placing Misfits.—Experience has shown that boys settle well, but in the nature of things there are bound to be misfits. Even employers are not always what they might be. There is no possible guarantee that a lad will be comfortably settled in his first situation, and this is where the Army's organisation is particularly effective. Among the boys there are the proverbial 'rolling-stones' as well as a large percentage who want to improve themselves and to see the world. The record of the re-placings of the 594 boys trained and emigrated in 1925, up to the end of December 1926, is a very useful guide to what may be expected after boys have arrived overseas. Re-placings were as follows:—

Number of times re-placed	.	.	.	1	2	3	4	5	6	over 6
Number of boys	.	.	.	141	87	55	28	11	1	5

Percentage still on Farms.—It is worthy of note, however, that of the 594 youths settled overseas in 1925, 86 per cent. were known to be still on farms on December 31, 1926, while but 6½ per cent. were to be found in large cities.

Instance of what a Youth can do.—One instance may be given of many of individual progress made possible by General Booth's scheme for boys. A young miner of eighteen arrived in Australia in January 1925. By December of the same year he repaid to the Army the expenditure incurred on his behalf out of Army funds. Then solely by his earning capacity on an Australian farm he was able to pay the migration costs of his father, mother, brother and sister. He therefore nominated them, and they arrived in Australia on October 21 last. Thus within twenty-two months this young fellow had done remarkably well. A friend who recently returned to this country, and who actually saw him, brought the information that on the arrival of his relatives this young man took a week's holiday, met them, and handed his mother £15 for temporary expenses. The father and brother are now in good situations.

Experimental stage passed.—But this work has long passed the experimental stage, for during the past twenty-five years the Army has happily and successfully transplanted 160,000 folk—men and women, and children—from the British Isles to the King's Oversea Dominions. The failures over all have amounted to less than 1 per cent.

The determining Factor in Migration.—The founder of the Army, the late General Booth, grasped the essential fact that it was the absorbing power of the lands overseas, and not social or economic pressure at home, which must determine the flow of migration. By using the organisation of the Army, with its vast ramifications at home and overseas, and utilising to the full up-to-date methods of communication, the two problems have been paralleled—which incidentally is the means of solving both—of vacant lands overseas and unemployment at home; accomplished much good and useful work, and demonstrated in the unity of control peculiar to the Army's system the essential lines on which the work of transplantation must be carried on. Work has been so arranged that every worker emigrating under the auspices of the Army has sailed with an assurance that work and a welcome have awaited him or her on arrival.

An aid to Creation of Trade.—Trade can be created by agricultural employment, and opportunities of profitable employment exist in so many parts of the Empire that our economic ills could be substantially cured were we to make use of more widely so simple an expedient as training in elementary agriculture for migration overseas. Even if the training of boys for farm work, with which this paper particularly deals, were the only attempt made to turn non-producers into producers, the result, if the work were undertaken on adequate lines, would be largely to improve the Empire's economic outlook. Apart from this important result there would be incalculable benefit to health and moral questions, and the British race would in an increasing degree be regenerated against the present danger of degeneration.

Of course no Empire Schemes for Migration and Settlement of Boys can be entirely satisfactory unless they are followed or accompanied by the migration and settlement of larger numbers of women. It has always been the policy of the Salvation Army to do nothing to *accentuate* the disparity in numbers of the sexes in the Homeland and Overseas, but rather to emigrate more women than men. The recent Census showed approximately two million (2,000,000) more females than males in the British Isles. Overseas in many districts men outnumber women.

Population and Empire go together, and the day when our death-rate exceeds the birth-rate our powers in the councils of the world will begin to decline. I submit, therefore, that the Old Country can engage in nothing more important and nothing more profitable than the transfer of tens of thousands of her young people to the vast undeveloped lands of the King's Overseas Dominions, under such conditions as I have outlined. The task before us is the opposite to that which confronted this country two generations back; then it was the transforming of a rural to an urban population, now it is the transforming of an urban population to a rural one.

Let us begin with the boys. Overseas the presence of these young people will be a strength to the Empire and their successful settlement a bond in commerce. Furthermore, the breath of the Homeland which they will carry, mingling with the freedom of the new lands, will make for the growth and development of a people well calculated to carry high the banner of our Christian civilisation: ever ready to sustain the best British traditions and well able to develop the Great Heritage which, in the good Providence of God, are ours.

SECTIONAL TRANSACTIONS.

SECTION A.—MATHEMATICAL AND PHYSICAL SCIENCES.

Thursday, September 1.

(Communications on Textiles, received at special sessions, will be found on p. 411 *seq.*)

(For references to the publication elsewhere of communications entered in the following list of transactions, see p. 430.)

Prof. R. A. MILLIKAN.—*The Relations between the Spectra emitted by the Atoms of the First Row of the Periodic Table in all Stages of Ionization.*

Mr. A. C. MENZIES.—*Regularities in Fuse Spectra.*

Dr. W. HEISENBERG.—*Recent Progress in Quantum Mechanics.* (Followed by Discussion. Mr. R. H. FOWLER, F.R.S., Dr. H. T. FLINT and others.)

Mr. H. JONES.—*Electron Impacts.*

DEPARTMENT OF MATHEMATICS.

Prof. H. W. TURNBULL.—*Non-commutative Algebra.*

The fundamental laws of algebra which provide axioms of the subject can be dealt with much in the same way as those of geometry. Experience has shown that the surrender of the law $a \times b = b \times a$ for multiplication leads to interesting results, notably in the theory of matrices and of q -numbers. The finite matrix, as discovered by Cayley, is a powerful symbol in discussing such questions as orthogonal transformations and (what is nearly the same thing) those of the restricted relativity in physics. The infinite matrix, which has many properties in common with the finite, introduces other possibilities also, which it shares with the q -number. For example, the formula

$$pq - qp = \text{constant}$$

is impossible for the Cayley matrix, but possible for the infinite matrix if certain tests for divergency are satisfied. Differentiation can be extended in at least two ways to functions of variables in this non-commutative field. Dirac has discovered one type of differentiation which has immediate place in quantum physics. Another type yields results more directly applicable to functions of a finite matrix.

Friday, September 2.

Joint Discussion with Section B on *The Structure and Formation of Colloidal Particles.* (See p. 317.)

Report of Committee on *Seismological Investigations.* (See p. 215.)

Dr. C. R. DAVIDSON.—*The Determination of Stellar Temperatures.*

DEPARTMENT OF MATHEMATICS.

Prof. W. P. MILNE and Mr. F. P. WHITE.—*Noether's Canonical Curves.*

Noether has shown that the general plane curve of genus p can be represented point by point on a curve of degree $2p - 2$ in space of $p - 1$ dimensions. The object of the communications is to describe as far as possible the fundamental properties of the Canonical Curves for $p = 3, 4, 5, 6$.

Monday, September 5.

Presidential Address by Prof. E. T. WHITTAKER, F.R.S., on *The Outstanding Problems of Relativity*. (See p. 16.)

Prof. P. DEBYE.—*The Polar Properties of Molecules*.

Dr. W. KOLHÖRSTER.—*Some Experiments on Penetrating Rays*.

Prof. J. J. NOLAN.—*Ionization in the Lower Atmosphere*.

Afternoon Lecture by Prof. R. WHIDDINGTON, F.R.S.—*Luminous Discharge in Rare Gases*.

DEPARTMENT OF MATHEMATICS.

Prof. S. BRODETSKY.—*The Equations of the Gravitational Field in Two and in Three Dimensions of Space-Time*.

Experience has shown that in order to deduce gravitational fields in fewer than four dimensions of space-time care has to be taken to avoid obtaining what is merely a Galilean field. This question is discussed in regard both to the original equations of the gravitational field and to the modified form recently suggested by Einstein.

Tuesday, September 6.

Prof. C. G. BARKLA, F.R.S.—*The Coherence of X-rays and the J phenomenon*.

Dr. F. W. ASTON, F.R.S.—*A New Mass Spectrograph and the Whole Number Rule*.

Prof. E. N. DA C. ANDRADE.—*Note on a Molecular Theory of Liquid Viscosity*.

Mr. D. BROWN and Dr. E. F. BRETT.—*Secondary Emission from Metallic and Metallic Oxide Targets*.

Reports of Committees on *Tides, Upper Atmosphere* (see p. 255), and *Earth's Gravitational Field*.

DEPARTMENT OF MATHEMATICS.

Prof. W. E. H. BERWICK.—*The Arithmetic of Cubic Number-Fields*.

It was known as far back as Euclid's time that every whole number can be decomposed, in just one way, into a product of prime factors. When a renewed interest began to be taken in mathematics, after the Renaissance, interest was again directed to the science of whole numbers. One of the first steps taken was the enlarging of the conception of the term 'number' by introducing first a root of unity and secondly a quadratic surd into the field of operations. The general stage was reached by considering the system of numbers containing, in any arithmetical combination, an assigned algebraic irrationality. It was soon seen that there was a difficulty in defining the integral elements of such a system of numbers. No definition, in fact, could be constructed permitting every integer of an algebraic field to be uniquely expressed as a product of similar prime factors. The next step was the widening of the conception of the integral elements to render factorisation

into primes again unique, and the general lines on which a solution was ultimately obtained were outlined about a hundred years ago. It was Richard Dedekind who finally consolidated the whole theory some fifty years ago. Dedekind showed that, when the integral elements of a field of algebraic numbers are suitably defined, these integers can be combined (in accordance with rules advanced by him) into 'ideals,' and that every ideal is uniquely expressible as a product of prime ideal factors. These ideals can be arranged in a finite number of classes, the determination of which is one of the fundamental problems connected with the field. In some fields there is only one class of ideals, and every integer can then be factorised uniquely into primes, just as in the case of ordinary integers. A field of algebraic numbers possesses units, integers which divide every integer contained therein, and an important problem is to determine all the units of the field. There exist only three types of number-field in which as yet the class-number and all the units can be infallibly determined in a finite number of arithmetical operations.

MR. B. M. WILSON.—*Ramanujan's Work on Congruence Properties of the Number of Partitions of n .*

By numerical evidence, based upon calculations made by MacMahon, Ramanujan was led to conjecture the truth of the following theorem :

If $\delta = 5 \cdot 7^b 11^c$, $24\lambda \equiv 1 \pmod{\delta}$, and $n \equiv \lambda \pmod{\delta}$, then $p(n) \equiv 0 \pmod{\delta}$.

The truth of this conjecture has been established only in five independent special cases and in the few other special cases which can be deduced immediately from these five. In addition to Ramanujan's own publications on the problem and a memoir posthumously edited for publication by Hardy, there exists a long but very incomplete manuscript of Ramanujan, now in the hands of his editors, which contains the results he had obtained up to his death. He there considers also congruences with moduli 13, 17, 19, 23, 29 and 31.

The paper is a report on the methods and scope of Ramanujan's researches, published and unpublished, on this subject.

MR. A. E. INGHAM.—*The Analytical Method in the Theory of Numbers.*

A general account of the method of Hardy and Littlewood as applied to Waring's problem, including some discussion of the more recent developments based on the analysis of the 'singular series.'

DEPARTMENT OF COSMICAL PHYSICS.

Joint Discussion with Sections C and K on *The Climates of the Past.*
(See p. 386.)

SECTION B.—CHEMISTRY.

(Communications on Textiles, received at special sessions, will be found on p. 411 *seq.*)
(For references to the publication elsewhere of communications entered in the following list of transactions, see p. 430.)

Thursday, September 1.

Presidential Address by Dr. N. V. SIDGWICK, F.R.S., on *Co-ordination Compounds*. Followed by Discussion—Prof. G. T. MORGAN, F.R.S., Prof. C. K. INGOLD, F.R.S., Dr. S. SUGDEN, Dr. F. G. MANN. (For Address, see p. 27.)

Dr. SUGDEN.—The physical reality of residual valencies shown by the optical activity of co-ordinated compounds of beryllium, copper, platinum, &c., is discussed. A definite picture of residual affinity is offered by the singlet linkage. Application of the rules of the extended electron valency theory to (a) acetylacetone and its metallic derivatives, (b) compounds of co-ordination number 6, discussing the isomerides possible on (i) the octahedral theory and on (ii) the singlet theory, (c) odd co-ordination numbers, (d) 'molecular compounds.'

AFTERNOON.

(a) Visit to works of Messrs. Wood Bros. Glass Co., Barnsley.

General manufacture of glass and glassware, including the processes involved in making scientific and laboratory glassware.

Prof. W. E. S. Turner, of the Department of Glass Technology, University of Sheffield, kindly assisted in showing the party round the works and explaining the technical processes.

(b) Visit to the British Research Association for the Woollen and Worsted Industries, Torrington.

Mr. A. T. KING.—*The Chemical Aspect of Wool Research.* (See p. 411.)

Friday, September 2.

Joint Discussion with Section A on *The Structure and Formation of Colloidal Particles.* Sir WILLIAM H. BRAGG, K.B.E., F.R.S., Prof. Dr. H. FREUNDLICH, Prof. R. WHYTLAW GRAY, Dr. F. L. USHER, Mr. B. N. DESAI, Mr. J. EWLES.

Prof. FREUNDLICH.—A distinction between amorphous, crystalline but not orientated, and crystalline with orientation, forms of colloidal particles may be made by employment of the X-ray method of analysis.

The two factors influencing the structure of a colloid particle are the rate of condensation of the molecules and the rate of their orientation in the crystal lattice under the influence of the crystal forces. While the crystal forces are extremely great in metals, thus giving rise to crystalline colloids of the metals, it has been possible to prepare amorphous silver colloid by rapid condensation and freezing.

Some indication of the shape of the particles may be obtained by optical methods, and particles which are pear-, spherical-, and rod-shaped, and in the form of lamellar plates of various materials have been examined, as well as the gradual transition from one form to the other with age.

Prof. R. WHYTLAW GRAY.—*The Process of Coagulation in Smokes and the Structure of the Particles.*

It has been found that these systems are unstable and that the particles are continually coagulating. Consequently, it is difficult to obtain the same degree of dispersion as in liquid sols. The analogy between these two classes is more apparent than real. Recently a reliable method of following coagulation has been worked out, and the results will be described.

The larger smoke particles are of microscopic dimensions and it has been found possible to obtain direct information about their structure.

Dr. F. L. USHER.—The formation and growth of colloidal particles from molecules are considered in systems from which crystalline structure is absent. The formation of nuclei depends only on the degree of supersaturation and the interfacial tension; while the growth of the nuclei, in absence of stabilising factors, depends on the relation between the rate of production of the molecules of the disperse phase and the number of partially grown particles already present. In stable liquid-liquid systems the particles grow only to a limiting size determined by the electrical conditions of their surface. There is independent evidence of a surface condition which should produce a type of distribution of sizes similar to what is observed.

AFTERNOON.

Visit to the works of Messrs. The Yorkshire Coking and Chemical Co., Ltd., and of Messrs. Hickson & Partners, Ltd., Castleford.

The Yorkshire Coking and Chemical Co.—Coke oven and by-product recovery plant, including sulphate of ammonia and benzene recovery. Messrs. Hickson—Manufacture of acids and synthesis of dye-intermediates and some dyestuffs from the crude benzol recovered from the coke ovens. The complete manufacture of certain dyestuffs from the coke ovens to the finished product is thus shown.

Monday, September 5.

Discussion on *The Chemistry of Hormones*. Prof. G. BARGER, F.R.S., Prof. H. S. RAPER, C.B.E., Mr. F. H. CARR, C.B.E., Prof. J. C. DRUMMOND, Prof. E. C. DODDS, Prof. J. MELLANBY.

AFTERNOON.

Visit to the works of Messrs. L. B. Holliday & Co., near Huddersfield.
General manufacture of dyestuffs.

Tuesday, September 6.

Prof. H. M. DAWSON.—*New Developments in the Study of Acid Catalysis*.

Prof. JOHN READ.—*Researches on Menthones, Menthols and Menthylamines*.

Mr. W. A. WIGHTMAN.—*Multipplanar Rings and Some Consequences of Strainless Motion*.

Dr. W. WARDLAW.—*Co-ordination Compounds of Molybdenum*.

Dr. J. A. V. BUTLER.—*The Effect of an Electric Field on the Adsorption of Ions and neutral Molecules at the Interface of Mercury and Aqueous Solutions of Electrolytes*.

AFTERNOON.

Visit to the works of Messrs. Joseph Watson & Sons, Ltd., Whitehall Road, Leeds.

The various processes of soap manufacture, the distillation of glycerine, and the production of caustic soda.

SECTION C.—GEOLOGY.

(For references to the publication elsewhere of communications entered in the following list of transactions, see p. 431.)

Thursday, September 1.

Prof. A. GILLIGAN.—*The Geology of the Leeds District*.

Mr. W. S. BISAT.—*The Correlation of the Carboniferous Beds of Western Europe*.

Thanks to the great exposures of goniaticite-yielding beds in the Pennine area of the North of England, the zonal analysis of the middle portion of the Carboniferous sequence has been carried out to an extent which enables practically all the goniaticite-yielding beds of Western Europe to be correlated easily with some portion of the English sequence.

Such correlations have been obtained in Belgium, Holland, Westphalia, N. of France and Portugal. They also exist farther afield, as in the Sahara and United States.

In Scotland, Northumberland and Silesia the almost complete absence of goniaticites makes correlation more difficult, and to a large extent dependent on the broader floral zones. Also for the main portion of the Lower Carboniferous in all districts we

are still dependent on the coral-brachiopod sequence. Similarly in the Middle and Upper Coal Measures of the Midland Province of England and the equivalent beds abroad we are dependent for zonal analysis mainly on the freshwater mollusca and the flora.

It would, however, appear that, taking the Midland Province of Gibson as a whole, and including in it all the Pennine area south of the Craven Faults, we delimit area extremely suitable for use as a type area. Not only is the sequence approximately complete (including beds not yet recognised elsewhere), but the goniatite-yielding phase is a widespread one, and affords a most delicate index for correlation purposes. Also the exposures at the junction of this phase with the coral-brachiopod phase of the Northern Province are excellent, and offer the most promising avenue yet discernible for a more accurate correlation and explanation of the two great marine facies.

Miss EMILY DIX and Dr. A. E. TRUEMAN.—*Marine Horizons in the Coal Measures of South Wales and the North of England.*

The importance of marine bands as datum planes in the correlation of the Coal Measures has been recognised for some years, and in Nottinghamshire and Yorkshire, and North Staffordshire, several marine bands have been much used in determining the structure of the coalfields. The two most noteworthy are the Mansfield Marine Bed (the Gin or Speedwell band of North Staffordshire) and the First Marine Bed (the Lady Coal band of North Staffordshire). These appear to indicate widespread submergences which affected simultaneously a wide area in the North of England.

In the South Wales Coalfield there has been little information concerning marine horizons, but an examination of cores of recent borings has revealed the existence of several well-marked horizons, two of which may be compared with the Mansfield and First Marine Beds. They agree closely in fauna, and they likewise occur near the top of the *Anthracomya pulchra* Zone. They appear to have been the latest marine episodes in all these areas. Earlier marine horizons are known in South Wales in the *Carbonicola ovalis* Zone and possibly in the *A. modiolaris* Zone.

Mr. W. S. BISAT.—*The Junction of the 'Upper' and 'Lower' Carboniferous Strata.*

The view that the deposition of the Carboniferous beds formed everywhere an unbroken sequence from bottom to top has long since been exploded, but the exact status of such break or breaks as occur in the succession has still to be determined.

It is by no means clear that a twofold division has any physical basis when Western Europe is viewed as a whole.

In Yorkshire a considerable break occurs at the junction of the Mountain Limestone and the basal beds of the Millstone Grit, but this break is associated with, and is probably largely caused by, a median ridge in the Carboniferous geosyncline of Northern England. This ridge, elusive though its character may be, served as an effectual barrier between the Midland Province of Gibson, and a Northern Province which included Garwood's North-western Province and the Northumberland-Durham area.

From the researches of Tonks and Hudson on this break in Yorkshire at the junction of the Yoredale rocks and the Millstone Grits, it would appear that the barrier itself moved northwards in Grit times, and that the Midland Province increased in area at the expense of the Northern Province. Apart from this median ridge with its attendant though obscure phenomena of knoll-reef limestones, breccias and facies-changes, there appears no important break in the North of England succession, except perhaps at the margins of the basins and around the Lake District and the Derbyshire Peak.

In S. Wales and Somerset there is a much more important break at the junction of the Limestone and Grits, and perhaps to a lesser extent the same is true of Westphalia, though here it is difficult to know how much of the apparent non-sequence is due to lack of exposure or barrenness of the strata.

Mr. W. S. BISAT.—*Some Episodes in the 'Millstone Grit' Period.*

Thanks to the detailed zonal analysis of the Millstone Grits, it is now clear that there were several major outwashings of coarse grit into the deltaic area of the Midland Province, with intercalated marine periods of considerable extent. The earliest such grit invasion appears to be that of the Grassington and Pendle Grits, which form

a great thickness of beds extending from North Yorkshire down to Pendle Hill, but are apparently absent farther south. The second such invasion was that of the Kinderscout Grit and associated beds, which are of great thickness in Derbyshire, and dwindle away northwards to a few feet near Clapham. Of less importance and not so clearly defined is the invasion represented by the Third Grit of Lancashire, which has a maximum in the west of Lancashire. Lastly, we have the Rough Rock extending in one unbroken sheet perhaps over the entire Midland Province, and in its regular character showing a marked contrast to the preceding great lenticular masses of grit.

Mr. R. G. HUDSON.—*A Mid-Avonian Unconformity in the Craven Lowlands.*

AFTERNOON.

Excursion to Bell Busk and Skipton.

Friday, September 2.

Prof. P. G. H. BOSWELL.—*The Cleavage-Fan in the Ludlow Rocks of the Denbighshire Moors and Clwydian Range.*

One of the most interesting tectonic features found by Mr. Howel Williams during his investigation of the Snowdon district of North Wales was the presence of a 'cleavage-fan.' A similar fan has been traced in the area of Ludlow rocks forming the Denbighshire Moors and the Clwydian Range (which is separated from the Moors by the down-faulted area of the Vale of Clwyd).

The strike of the cleavage is approximately east-west; in the moorland area it strikes frequently north of east, and in the Clwydian Range it often swings to north of west. Where hard sandstone bands intervene in the muddy Salopian sediments, or where the rocks are disturbed by post-Caledonian faulting, the cleavage-direction varies considerably and may, for the purpose of this discussion, be regarded as anomalous.

In the northern part of the Moors, behind Abergele and Colwyn Bay, the cleavage displays a southerly dip at angles increasing from 45° to 80° as we proceed southwards. Along an east-west belt through Llanefydd, Llanfair-Talhaiarn, and Pentre-Llangerniew, the cleavage becomes vertical or oscillates rapidly, dipping towards the north or south at angles greater than 80° . South of this area, over the greater part of the Moors, the cleavage-planes dip steadily northwards at angles varying from 40° to 80° .

In the northern part of the Clwydian Range the cleavage is southward-dipping. Over the central part it is vertical or rapidly oscillating, and in the southern part it is consistently northward-dipping.

The formation of the fan is attributed to deep-seated movements due to pressure acting from the directions of the northern and southern margins of the geosyncline of Ludlow rocks, and directed towards the centre.

The middle or 'axis' of the cleavage-fan is in places translated by post-Caledonian faulting. Displacement by tear-faulting, as distinct from vertical movement along the fractures, may thus be determined.

Dr. G. SLATER.—*The Structure of the Disturbed Chalk and Diluvium on the East Coast of the Isle of Rügen (Jasmund District), Germany.*

The classical disturbances on the east coast of the Isle of Rügen (Jasmund District) extend from Sassnitz to Stubbenkammer, a distance of five miles. The cliffs are composed of chalk associated with drift. The former belongs to the Upper Senonian Pencil Chalk and is unstratified, the bedding being indicated by flint-bands. A representative fauna was collected from the Sassnitz pits and confirms the opinion of previous workers that this zone is equivalent to the Trimmingham horizon of England. Macroscopic fossils in the cliffs, however, are scarce. The drift belongs to two series:—

- (a) Lower Diluvium, associated with the disturbed chalk. This drift is tripartite, two boulder clays being intercalated with stratified sands of fluvial and fresh-water origin.

- (b) Upper Diluvium, which rests unconformably on the outcrops of the disturbed deposits.

To the south, near Sassnitz, the general strike of the disturbed chalk is NNW-SSE, and there is a general dip of the beds approximately to the south, in the coast sections.

Traced from north to south the structure may be divided into three zones:—

- (1) A 'hörst' of chalk to the north forming the lofty cliffs of Stubbenkammer, bent into a magnificent sigmoid curve at the Königsstuhl bluff.
- (2) A zone of thrust planes, in the central area between Sassnitz and Kolicker Ufer, a distance of three miles. In this zone the Lower Diluvium is repeatedly intercalated in the chalk.

In each case the lower boulder clay rests evenly on the underlying inclined face of the chalk, while a thrust plane is associated with the 'hanging wall' of the overlying chalk, the 'sole' of the thrust transgressing the tripartite succession of the drift, disturbing and, in places, removing either the whole or portions of the upper members. The chalk, between adjacent thrust planes, always assumes the form of a truncated flow-curve or squeezed anticline. All observers agree that the lower boulder clay consists of isolated strips severed from a once continuous sheet; it is therefore a valuable datum-line. This zone proves, in a convincing manner, imbricate or 'schuppenstruktur,' due to ice-action, repetition occurring at least fourteen times.

- (3) The third zone occurs near Sassnitz and is characterised by a peculiar development of 'false-domes,' and 'pseudo-synclines' or drift-lined hollows in the chalk, associated with thrust.

The structure is analogous to that of the Møen area south of the Sommerspir, described at the Oxford Meeting last year.

The cost of this investigation was defrayed by a grant from the Sladen Trustees, 1926, for which I express my thanks.

Dr. G. SLATER.—*The Structure of the Mud Buttes and Tit Hills of Alberta, Canada.*

Examination by O. B. Hopkins of the district in question showed Cretaceous beds surrounding the buttes and hills dipping gently southward, while in the Mud Buttes the sediments, disposed irregularly in miniature folds, prevailingly dip about 30° N.E. The anomalous structure was tentatively explained by Mr. Hopkins as due to pressure of an advancing ice-sheet against an obstructing outcrop which was moved *en masse* with consequent thrusting and folding.

Studies by the writer in 1924 confirm the essential point of Hopkins' view—namely, that the Mud Buttes and Tit Hills owe their origin to ice-action; but the detailed relations observed in the field and described in this paper show that these interesting local topographical features are built up by accretions in the form of *comparatively thin lenticles* of englacial material, the origin being similar to that of deposits investigated at several European localities.

Structurally the Mud Buttes present, from south to north, three zones: (1) bluffs with little compression and no overfolds, this zone being analogous to a 'hörst'; (2) a zone of compression; (3) overfolds forming the highest part of the hills. The structure was built up from south to north, but movement of the beds was in the reverse direction.

The moulding of material forming the southern bluffs has been from below upwards. The material is composite in character and has been moved as individual ledges or lenticles along thrust planes. Against the sigmoid curve and associated thrust plane on the exposed side of the bluffs, which acted as a 'hörst,' the central zone of compressed material has been squeezed, resulting in the formation of folds, and rippling. The upper surface of the central zone finally formed a glide plane for the passage of other material forming zone 3. This material moved in the form of overfolds dissected by thrust planes, the whole having a radiating structure. The exposed or northern flank formed one of the major thrust planes of the area. Although the axes have a general east-west trend, there is a slight southerly deflection on the eastern flank,

and this is associated with the production of a hummocky area. Pressure was greatest in the centre of the area.

This structure is a clear example of glacial tectonics. Lenticles of englacial material became incorporated in ice during its southerly passage over Cretaceous strata, and this material, embracing sandstone, &c., must have been derived from outcrops in the vicinity, the plane of 'gumbo' clay to the north forming a suitable floor for ice movement. The repetition of similar lithological material by thrust produces imbricate or 'schuppenstruktur.' Material between two neighbouring thrust planes may be regarded as being moved *en masse*. The contortions include (a) compression folds due to lateral pressure, and (b) flow curves of subsequent deformation by pressure. They display drag phenomena. The association of thin plastic clays with sand offered a most favourable material for incorporation as englacial material in a moving body of ice. The structure represents the final stages of the deglaciation of the area and belongs to the stagnant glacier type of glacial tectonics.

The cost of this investigation was defrayed by a grant from the Sladen Trustees, 1924, for which I express my thanks.

MR. HERBERT P. LEWIS.—*The Zoning of the Avonian Rocks in the South of the Isle of Man.*

The lower beds (Lower Limestone of Cumming), as developed above the Basal Carboniferous Conglomerate from Cass-ny-Hawin to the east side of Castletown Bay, at Port St. Mary, at Ballasalla and at Ballohot, find their closest parallel in the *Michelinia* and *Productus corrugato-hemisphericus* zones of the N.W. Province as defined by Prof. Garwood.

In the *Michelinia* zone, which in places is oolitic, the lowest persistent fossil band is rich in *Syringothyris cuspidata* var. *exoleta* and contains *Athyris glabistria*, *Cyathophyllum multilamellatum*, &c. Higher in these C₂ beds the *Chonetes carinata* band with *Michelinia grandis*, *Clisiophyllum multiseptatum*, &c., has been traced from Cass-ny-Hawin to the east side of Castletown Bay. The highest *Michelinia* beds at Ronaldsway contain *Punctospirifer glabricosta*, *Zaphrentis* cf. *enniskilleni*, and bryozoa. These and associated fossils occur near the base of the limestone and above beds with *Syringothyris* at Port St. Mary. The same band is found at Ballasalla and Ballohot. At Port St. Mary and Ballasalla, immediately above this band, are beds containing mollusca ('gasteropod beds') which indicate a low horizon in S₁. At Ballohot the presence of *Nematophyllum minus*, *Chonetes papillionacea*, &c., indicates the top of S₂. In the intervening S beds *P. corrugato-hemisphericus* is found, but fossils are not common.

In the coast-section at Strandhall *Nematophyllum* cf. *minus* occurs below D₁ beds which yield *Cyathophyllum murchisoni*; a higher band with *Chonetes* cf. *comoides* is probably near the top of D₁. Beds near the top of this section contain *Zaphrentis costata* and show analogy to the *Cyathaxonia* beds of Scarlet which are near the top of D₁. The Scarlet-Castletown beds with *Prolecanites compressus* (*Merocanites*) pass up into beds with a knoll fauna at Knockrushen.

The knoll limestone (Poolvash Limestone of Cumming) is divisible into two zones: a lower with *Beyrichoceras micronotum* and *B. vesiculifer*, and an upper with *Goniatites crenistria* and *Beyrichoceratoides truncatum*. Near the base of the higher zone is a coral band with *Dibunophyllum* cf. *muirheadi*, &c.

The black limestone (*Posidonomya* Schist of Cumming) yields *Prolecanites serpeninus*, *Goniatites punctatus*, and *G. falcatus* near the base, below the interstratified 'breccia bed' of knolly limestone which contains *Cyathaxonia*, *Emmonsia parasitica*, and small *Michelinias*. Above the 'breccia bed' the black limestone fossils include *Posidonomya becheri*, *G. falcatus*, and goniatites of the *G. striatus* gens. These lower P₁ beds of Bisat are the highest beds exposed. The Poolvash beds are comparable with those of Cracoe.

Wheeler Hind's view that none of the limestone was deposited before D₂ time is therefore considered untenable, as there is evidence of continuous deposition from C₂ until Lower Bowland Shale time. Cutting out of the lower beds between the *Punctospirifer* band and the basal conglomerate at Port St. Mary indicates westward transgression of the C₂—S₁ sea on to a pre-Carboniferous ridge of land which, it is thought, never became wholly submerged in Lower Carboniferous times.

Dr. S. W. WOOLDRIDGE.—*The Denudation Chronology of South-east England.*

This paper attempts to evaluate and to arrange in order of date the several episodes of planation legible in the land-forms of S.E. England (Weald and London Basin). Brief reference is made to the earlier episodes, more particularly the Miocene sub-aerial planation whose work was completed by the Lenhamian sea. The several stages of the post-Lenhamian rejuvenation of the river-system is traced and emphasis laid upon the widespread occurrence of a dissected plain at 200-250 feet O.D. This feature is traced in the several water-gaps of the northern Weald and in the country lying north and south of them. Its occurrence in the London Basin, north of the Thames, is demonstrated and its relation to the glacial deposits discussed. From this and other evidence indications of age are obtained and it is interpreted as a base-level of late Pliocene or early Pleistocene date. Some description is given of the character of the deposits resting on the plain, and attention is drawn to the prevalence of drainage-modifications as evidenced by wind-gaps, on the surface of the plain. The question of wider correlations is broached, though the evidence does not permit of definite conclusions being drawn. Some interest attaches to the regions, notably East Anglia and parts of the southern Weald, where the 200-foot platform cannot be traced and reasons for its absence are suggested.

The Rev. Dr. S. G. BRADE-BIRKS.—*The Bionomics and Affinities of Archipolypoda.*

Scudder (1882)¹ in his study of Archipolypoda from the Carboniferous rocks of the United States suggested a possible aquatic habitat for *Acantherpestes major* on the strength of the anatomical features exhibited by the ventral plates. He interpreted the openings seen on a typical ventral plate as a pair of medioventral branchial cups, a more laterally placed pair of openings for the insertion of the legs and, outside the base of each leg, an oblong-ovate spiracle. Verhoeff (1926)² has compared his own interpretation of like structures in *Acantherpestes gigas* with that of Fritsch (1899).³ Since Jackson and the Brade-Birkeses (1919)⁴ gave their account of *Palaeosoma giganteum*, a new specimen of *Euphoberia ferox* from the Northumberland coal measures has become available for study and for comparison with other specimens of the same species elsewhere, and with the specimen of *Palaeosoma giganteum* preserved in the Manchester Museum.

Recent Colobognatha, Thysanura and Symphyla exhibit some structures worthy of comparison with those of the Archipolypoda. This makes a discussion of the bionomics of a number of species possible and helps to throw light upon the origin of the arthropod land fauna.

The structure and affinities of the genus *Kampecaris* are considered.

Prof. P. G. H. BOSWELL.—*The Source of the Constituents of the Lower Greensand and other Aptian Sediments.*

A review of the palæogeographic features of the British area in Aptian times indicates that the possible land-masses which might have contributed detrital material to the Aptian sediments were (1) the now-buried Palæozoic floor under the east of England, (2) the south-western Hercynian massif, (3) the western and north-western Palæozoic rocks with their fringe of Jurassic and Triassic strata, and (4) smaller masses of ancient rocks partially buried under newer sediments in the Midlands. The peculiar characters of both coarse and fine detrital constituents of the Lower Greensand, as determined by numerous investigators, indicate that no known British sediments can be regarded as their source. Only newly exposed metamorphic rocks (and probably acid igneous rocks) could have yielded the fresh material of the Greensand. Unfortunately, the older Palæozoic rocks known from deep borings under eastern England are not of a type to satisfy the requirements, nor are those of the west and north-west of England

¹ *Mem. Boston (U.S.A.) Soc. Nat. Hist.*, vol. 3, No. 5, p. 155, &c.

² 'Fossile Diplopoden,' in Bronn's *Klassen und Ordnungen des Tier-Reichs*, 2. Abt. 2. Buch, p. 330, &c.

³ *Fauna der Gaskohle . . . Böhmens*.

⁴ *Geol. Mag.*, Dec. 6, vol. 6, p. 406, &c.

and Wales. The south-western provinces (including Devon and Cornwall and Brittany) may have yielded the detrital constituents, but the coarseness, variety and freshness of the heavy minerals of the Aptian of the northern Midlands and Yorkshire appear to demand a source closer to hand and at present unknown to us. The long-standing puzzle of the source of the Aptian deposits must therefore still be regarded as unsolved.

AFTERNOON.

Excursion to the Drifts of the Aire Valley.

Saturday, September 3.

Excursion to examine the Millstone Grits and Lower Coal Measure Rocks of Huddersfield and Blackstone Edge.

Sunday, September 4.

Excursion to South-east Craven.

Monday, September 5.

Presidential Address by Dr. HERBERT H. THOMAS, F.R.S., on *The Tertiary Plutonic Centres of Britain.* (See p. 43.)

Dr. G. W. TYRRELL and Mr. B. H. BARRETT.—*The New Red Sandstone Rocks of Arran.*

The first complete stratigraphical succession of the New Red Sandstone of Arran was established by Prof. J. W. Gregory.¹ At the same time the senior author (G. W. T.) contributed a description of several critical sections;² and the junior author (B. H. B.) has recently described the petrographical characters of the Brodick Breccia, and has traced the provenance of its constituents.³ The present communication confirms

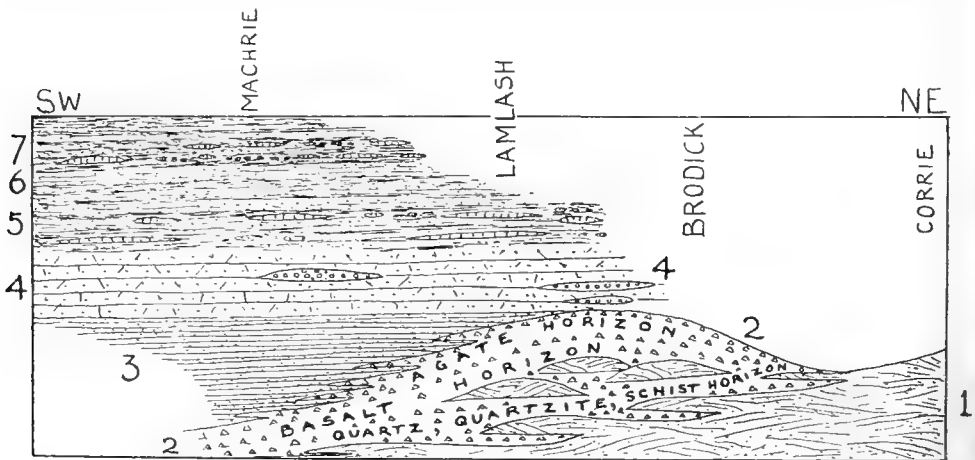

DIAGRAMMATIC SECTION OF NEW RED SANDSTONE ROCKS IN ARRAN.

1. Corrie Sandstone; 2. Brodick Breccia; 3. Lamlash and Machrie Sandstone;
4. Ballymichael and Glen Dubh Sandstone; 5. Lag a Bheith Marls and Cornstones;
6. Auchenhew Sandstone and Shales; 7. Levenacoroch Marls and Cornstones.

¹ 'The Permian and Triassic Rocks of Arran.' *Trans. Geol. Soc. Glasgow*, xv. pt. 2, 1914, pp. 174-87.

Ibid. pp. 188-99.

The Permian Breccia of Arran.' *Ibid.* xvii. pt. 2, 1925, pp. 264-70.

Prof. Gregory's succession while adding to it in many details. A diagrammatic section across the Arran New Red Sandstone from N.E. to S.W. (fig. 1) shows the dune-bedded, round-grained red Corrie Sandstone (Brodick Freestone of Prof. Gregory) thinning toward the south-west and interdigitating with the Brodick Breccia. Isolated masses of dune-bedded sandstone intercalated within the Brodick Breccia, well seen on the Corriegills shore, are interpreted as fossil dunes. The Brodick Breccia is divided into three horizons which have been found to be remarkably persistent. The constituents of the basal parts of the breccia are mainly vein-quartz, quartzite, and schist of Highland provenance, and fragments of this nature are found, although in smaller amount, throughout the breccia. In the central horizons, however, a great number of basalt pebbles come in, sometimes in such quantity and of such sizes as to suggest the near proximity of the distributing volcanoes, although the sites of these vents have not been discovered. The smaller basalt fragments are often well rounded, and one or two large sub-rounded masses even suggest bombs, but most of the larger pebbles are angular. So far as can be recognised the basalts are similar to those of the Permian vulcanicity of the Ayrshire mainland. Good sections of this horizon are to be found in the Glen Dubh Water,⁴ and on the Corriegills shore. Basalt pebbles persist up to the top of the breccia, but here numerous white-weathering agate pebbles appear, and are everywhere characteristic of the upper horizons.

Following upon the Brodick Breccia, and interdigitating with it to some extent, are thin-bedded red sandstones with some pebble beds. These are well exposed at Lamlash and Machrie. Then comes a thick post of white, yellow, and pink, massive calcareous sandstones, with a carious, yet smooth-surfaced, blocky type of weathering. These are best seen on the southern slope of Glen Dubh, Whiting Bay, and Ballymichael Glen. A few lenticles of conglomerate with well-rounded pebbles occur in it.

The upper part of the New Red Sandstone includes three distinct series: the Lag a Bheith Marls and Cornstones, well exposed in the headwaters of the Lag a Bheith (the Birch Glen, S.W. of Brodick); the Auchenhew Sandstones and Shales, with sharp-angled grains and mica flakes; and finally another series of marls and cornstones (the Levenorroch Marls and Cornstones).

The relations of the various horizons are indicated on the diagram, fig. 1. The Corrie Sandstone, Brodick Breccia, and the Lamlash-Machrie Sandstone are believed to be essentially contemporaneous formations.

Prof. G. B. BARBOUR.—*The Tertiary and Quaternary History of North China.*

An attempt is made to reconstruct the record of events by combining data involving the character of the deposits, inferred climatic conditions, faunal associations, migration of strandline, diastrophic movements, and physiographic stages.

After the Middle Mesozoic disturbances which finally fixed the major structures of the region, erosion peneplaned the land-surface; early Tertiary deposits are limited to local warp-basins. At no subsequent time did marine waters much overlap their present confines in North China.

In late Oligocene and early Miocene times, crustal dislocation and vulcanicity produced an irregular surface upon which erosion again took hold. This *T'anghsien* stage (Willis) yielded broad open valleys with residual clays and local gravels: the *Hipparion* (Pontian) fauna and other Pliocene vertebrates point to moderate steppe conditions.

Towards the close of the Pliocene slight movement led to ponding of rivers in the mountain areas. In the Sangkanho basin, Barbour, Licent, and Teilhard recently found a rich mammal fauna showing affinities with both Pliocene and Pleistocene types. The find is of special interest in view of Zdansky's discovery of two human teeth in Ch'ou-K'ou-Tien cave near Peking associated with vertebrate species, several of which appear to be identical with Sangkanho types.

Following on this *Sanmen* fluvio-lacustrine stage, renewed down-cutting by rivers drained the basins. A closely parallel succession of stages seems to have obtained in Central and South China, though the absence of faunal criteria prevents strict correlation.

The onset of colder dry conditions of the *Malan* stage (Anderson) marked a sharp

⁴ J. W. Gregory and G. W. Tyrrell, 'Excursion to Arran.' *Proc. Geol. Assoc.*, xxxv. pt. 4, 1924, p. 414.

contrast, though this change probably set in with varying vigour in different areas: locally basal gravels suggest transitional conditions of moisture, and it is to this horizon that the Ordos Palæolithic culture belongs.

During Pliocene times chemical weathering had penetrated deep into the surface of the Mongolian plain, but the residual decay products remained undisturbed.

In Pleistocene times uplift exposed this material to high winds that swept it over the border into China, depositing it as a blanket of loess as far south as the Yangtze valley. A characteristic fossil is the egg of the ostrich, *Struthio lithus*.

During the fluctuating stage of return to moister conditions, wind and water vied as agents of scour and deposit. The 'Dune-dwellers of Shabarakh' (? Azilian), whose implements were found by the Central Asiatic Expedition, presumably fall within this stage. The various Chinese Neolithic culture stages invariably lie on the upper surface of the main body of the torrential deposits of this *Panch'iao* stage.

The present stage of erosion has been stimulated by slight up-warping of the mountain hinterland. The coast-line of the Yellow Sea shows evidence of emergence only in one locality: elsewhere all points to a continued geosynclinal sinking of the delta area.

Mr. E. H. DAVISON.—*The Variation in the Composition of Cornish Granites and its Relation to the Occurrence of Tin Lodes.*

It has long been recognised that the Cornish tin lodes which occur in the granite are often accompanied by hydrothermal and other alterations of the country rock such as greisenisation, tourmalinisation, kaolinisation, &c. These intense types of alteration are usually confined to the immediate neighbourhood of the lode fissure, though in some cases they spread outwards for a considerable distance and cover large areas. The presence of any of these types of alteration is invariably suggestive of the presence of mineral lodes.

In many of the mining districts, however, the granite is for the greater part not affected by these drastic changes, and the aim of the work described in this paper was to discover if there is any constant difference in composition between the granite in areas free from lodes and that of the granite in areas where lodes are numerous. If any such difference in composition exists it would be of great help in deciding which areas are worth prospecting and which are not.

In order to solve the problem samples of granite were collected from as many localities as possible, including surface exposures in quarries and cliffs as well as underground exposures in mines. From these samples thin sections were cut and examined microscopically, while in many cases the rock was subjected to mechanical analysis to determine the proportions of significant minerals. As a result the granite was found to vary in composition as follows:—

Granite from areas free from mineral lodes.

Muscovite seldom present.

Biotite usually present in an unaltered condition.

Little or no tourmaline.

Fresh feldspars free from kaolinisation or sericitisation; well-formed crystals of feldspar.

Granite from areas with mineral lodes.

Muscovite always present.

Little or no biotite. When present the biotite shows alteration to chlorite.

Tourmaline almost always present.

Feldspars show partial sericitisation and occur in ill-formed crystals.

A further problem was afterwards attacked. It is a common experience to find that lodes vary in value along their strike—that is, they have zones of rich ore alternating with zones of low-grade ore which usually run diagonally down the dip of the lode. An attempt was therefore made to discover if there was an easily recognisable difference in composition between the granite near the poor (low-grade) lode and that near the rich (high-grade) lode.

The aid of the various mine managers was asked for and they kindly arranged for the collection of samples of the granite from near high-grade lodes and also from near low-grade lodes. These samples were treated as described above and the granite was found to vary as follows:—

Granite near rich lode.

Much muscovite, chlorite, and tourmaline.

Felspars much sericitised or kaolinised.

Granite near low-grade lode.

Some biotite, little tourmaline, felspars only slightly altered.

A limited number of copies of a paper giving detailed results are available for those specially interested.

Mr. E. H. DAVISON.—*The Cornish Pegmatites.*

Pegmatites occur in Cornwall both as veins in the granite and also as veins penetrating the overlying altered slates. When in the granite they are most common near the margin of that rock, but are also found well inside the granite mass, an instance being the pegmatite cut in Williams' shaft, Dolcoath Mine, which was cut at a depth of nearly 4,000 feet from the surface of the granite.

They vary much in coarseness of texture, some being exceptionally coarse with felspar crystals up to 18 inches in length and 4 inches square in cross-section, while others are little coarser than the normal Cornish granite.

In composition they also vary considerably. Quartz and orthoclase are invariable components, and a mica is usually present which may be muscovite, zinnwaldite, or gilbertite, biotite being rare. Tourmaline is a common constituent, while fluorite, apatite, pinite, cassiterite, wolfram, and mispickel also occur.

One of the characteristic features of the Cornish Pegmatites is the occurrence of a banded structure, the veins being built up of alternating bands of pegmatite and aplite or having a centre of pegmatite with selvages of aplite or of a much finer grained pegmatite. One dyke of pegmatite (at Trelavour Downs, St. Dennis) shows exceptional banded texture, the margins consisting of medium-grained brown (lithia-bearing) mica and felspar, followed by massive fine mica and then massive coarsely crystallised mica with a centre of coarse mica, felspar and quartz.

Another feature is the manner in which veins of pegmatite in the slate shade off into aplite and in some cases into quartz veins. This can be seen at Porthmeor Cove, Gurnard's Head, and was observed in the Roskear shaft, where veins of pegmatite were seen to pass into aplite, and aplite into quartz veins.

That the temperature was low at the time of solidification of the pegmatite is shown by the fact that pegmatite veins in the slate produce very little alteration in that rock at the contact. At Megilligar Rocks, near Porthleven, the largest vein of pegmatite, some 10 feet wide, alters the slate for a distance of only an inch or two from the margin, while the vein contains slate xenoliths of small and large size which show only an alteration selvage of about half an inch.

The close relation between the intrusion of pegmatite veins and the formation of mineral lodes is also shown by the occurrence of metallic minerals such as cassiterite, wolframite, mispickel, &c., in the veins, and this is supported by the occurrence of mineral lodes with pegmatite-like structure and containing patches of granitic material at points well outside the granite itself.

AFTERNOON.

Prof. W. G. FEARNSIDES.—*Report of the Dolgarrog Committee.* (See p. 276.)

Excursion to Ackton Hall Colliery.

Tuesday, September 6.

Joint Discussion with Sections A (Cosmical Physics Dept.) and K on *The Climates of the Past.* (See p. 386.)

Mr. H. C. VERSEY.—*Post-Carboniferous Movements in the Northumbrian Fault Block.*

By reason of its rigidity this area was unable to fold, and in consequence a large system of fractures originated, and the area was uplifted as a fault block. The

fractures are related to areas of heavy sedimentation in Carboniferous times. A saddle-shaped structure was produced and the thin cover of Carboniferous rocks on the rigid sub-stratum was wrinkled into low 'plis de couverture'—the Cotherstone and Middleton Folds. Relation of this movement to Whin Sill intrusion. The fault block, formed early, acted as a horst to the folds produced in the Pendle trough. Relation of these movements to the deposition of Permo-Trias east and west of Pennines.

AFTERNOON.

Excursion to the Permian Rocks of Harrogate and Knaresborough.

Wednesday, September 7.

Dr. A. R. DWERRYHOUSE and Mr. A. AUSTIN MILLER.—*The Glaciation of Radnorshire and Parts of the Adjoining Counties.*

We wish to place on record some preliminary observations on the district and to indicate the general conclusions at which we have arrived.

The work is being undertaken with the aid of a grant from the Research Board of the University of Reading.

Certain anomalies in the drainage of the country lying to the east of Clun Forest and Radnor Forest first attracted our attention, and it early became evident that the peculiarities were due to the action of ice during the Glacial Period.

The main facts as we see them at present are as follows:—

1. The country lying immediately to the west of Clun Forest, Radnor Forest, and the range of hills extending southwards from the latter to the gorge of the Wye near Builth Wells, was occupied by ice which was continuous with that of the Plinlimon Highlands and which was moving in a southerly direction down the valleys of the Ithon and Wye, and thence by way of Llanwrhyd Wells and Llandovery towards Llandeilo.

2. This ice rose to considerable heights on the western flanks of Radnor Forest and penetrated to some of the valleys on its eastern side.

3. A series of small lakes and Mawn (Peat) Pools mark the limit of this western ice at a stage during its retreat. They occur at heights varying from 1,250 to 1,600 feet from the latitude of Newtown (Montgomery) to that of Builth Wells in the south.

4. Much ice passed eastwards over the area of the Wye gorge and the valley of the Arrow, fanning out when it reached the more open country on the east side of the range.

5. A lobe of this glacier passed north-eastwards past Leominster, laying down a terminal moraine at Orleton, causing the easterly deflection of the River Teme past Tenbury.

6. The River Lugg and its tributaries were also diverted, several lakes and overflow channels resulting from the damming up of their waters by the ice. Of the overflows the Downton gorge and the valleys in the neighbourhood of Mortimer's Cross may be cited as examples, while the lakes which formerly existed at Presteign and in the Vale of Wigmore are typical of the latter.

We acknowledge much valuable information contained in the papers by the Rev. E. Grindley and others published in the Proceedings of the Woolhope Club.

Dr. A. RAISTRICK.—*Periodicity in the Glacial Retreat in West Yorkshire.*

In the valleys of the rivers Aire, Wharfe, Nidd, Ure, and Swale, of West Yorkshire, the earlier stages of the glacial retreat are marked by lakes impounded in the tributary valleys, and a very complex system of overflow channels cut by the lake waters over the lateral spurs of the valleys, sometimes accompanied by lateral moraines on the main valley slopes. These lakes and channels belong to two main periods of retreat, separated by a short period of readvance of the ice. A third stage of the main retreat is marked by numerous terminal moraines left on the main valley floors by the rapidly retreating and dwindling ice tongues of the valley glaciers. This retreat was frequently interrupted by brief periods of moraine formation, and it has been found that six principal pauses, with corresponding moraine belts, can be recognised, and the moraines are practically complete, in all five valleys. Most of the moraines were

breached during the ensuing period of retreat of the ice, and frequently connection can be traced between river terraces and the gorges through the moraines. Comparable terminal moraines in other parts of the Pennines, in Durham and Westmorland, and in parts of Cumberland, suggest that the periodic pause in retreat was due to a climatic periodicity affecting the North of England as a whole.

Mr. RATCLIFFE BARNETT.—*Geological Sections in the Sladen Valley, West Yorkshire.*

This paper gives an account of the method which was adopted to ascertain the nature of the strata in a section of the Sladen Valley, near Haworth, so as to prove whether the sites of two reservoirs were suitable for the construction of the reservoirs which it was proposed to build for the additional supply of water to the town of Keighley.

The sites had been adopted many years previously, but no attempt had been made to test the character of the sub-strata of the sites. These reservoirs were known as 'Bully Trees Reservoir' and 'Lower Laithe Reservoir' respectively.

On the line of the embankment of the proposed 'Bully Trees Reservoir' four trial borings were put down to depths varying from 100 feet to 151 feet from the surface of the ground. Six trial pits were sunk to supplement the bore-holes, the deepest reaching to 70 feet from the surface of the ground. The details of these bore-holes and trial pits are given in tabular form in Appendices Nos. 1 and 2 and in diagrammatic form in Diagram No. 2.

The results of these borings and pits are described in the paper and reasons given for the decision arrived at that the Bully Trees site was quite unsuitable for the construction of a watertight reservoir.

The bore-holes and trial pits which were put down to test the other site, that at 'Lower Laithe Reservoir,' are next described in detail and similarly shown in Appendices Nos. 3, 4 and 5. The results are also shown in diagrammatic form in Diagrams Nos. 7 and 8.

The results of these borings and pits are similarly described in detail and the inferences set forth by which it was concluded that a watertight reservoir was in all probability feasible at the Lower Laithe Reservoir site.

This reservoir has been constructed and has proved to be quite watertight.

The paper is illustrated by lantern slides.

Dr. D. A. WRAY.—*The Carboniferous Succession in the Central Pennine Area, with special reference to the Country between Todmorden, Rochdale and Huddersfield.*

The strata usually described as the millstone grits and lower coal measures are typically developed in the Central Pennine area, on the borders of Lancashire and Yorkshire.

This area was originally surveyed by the officers of the Geological Survey some sixty years ago: a detailed series of subdivisions was instituted, based largely on lithological considerations.

The detailed study of the fossils which occur at numerous horizons was taken up at a much later date, and it was the late Dr. Wheelton Hind who first paid attention to the Goniatites with a view to their establishment as zonal indices. The material then available, however, was insufficient for a thorough study of the group on ontogenetic lines. This has recently been taken up by Mr. W. S. Bisat, who has instituted a zonal sequence based on mutations and species of the genera *Reticuloceras* and *Gastrioceras*.

The present writer has geologically surveyed on the six-inch scale upwards of two hundred square miles of the Central Pennines and has found these zones to have a high stratigraphical value; by their means a complete correlation of the succession on both sides of the Pennine axis can now be confidently instituted, based entirely on palaeontological considerations.

The lower coal measures have also been studied in detail and a modified correlation is now presented. It is further claimed that the Arley Mine, Better Bed, Kilburn and Woodhead coals of Lancashire, Yorkshire, Derbyshire and North Staffordshire, respectively, are of close if not exact contemporaneity, and make a

suitable datum line for the subdivision of the upper Carboniferous (with the exception of the uppermost barren coal measures) into two great groups, viz. (1) a lower group, the *Lancastrian* of Bisat (Lanarkian of Kidston), characterised by massive grits, sandstones, and thin coals; and (2) the *Yorkian* of Watts (Westphalian of Kidston), containing practically all the main productive measures.

Mr. H. L. CHIBBER.—

(a) *The Lamprophyres and Associated Rocks of Mokpalin, Burma.*

(b) *The Volcanic Rocks of the Irrawaddy Delta.*

(c) *Ancient Metallurgy in Burma.*

(Taken as read, in the author's absence.)

Dr. W. F. P. McLINTOCK and Mr. J. PHEMISTER.—*Preliminary Note on a Torsion Balance Survey over the Swynnerton Dyke.*

Dr. FELIX OSWALD.—*A Mud Volcano at Shugo, Western Caucasus.*

SECTION D.—ZOOLOGY.

(Communications on Textiles, received at special sessions, will be found on p. 411.)

(For references to the publication elsewhere of communications entered in the following list of transactions, see p. 431.)

Thursday, September 1.

Presidential Address by Dr. G. P. BIDDER on *The Ancient History of Sponges and Animals*; followed by Discussion. (For Address, see p. 58.)

Mr. H. W. HERVEY.—*The Fertility of the Sea.*

The animal life in the sea is ultimately dependent upon the minute plants suspended in the water for its nourishment. Like plants on land, these require a sufficiency of light and of nutrient salts for profuse growth; the phosphates and nitrates in solution in the sea are at times almost entirely used up by the plants and consequently limit their growth. In general the deep water of the open oceans is rich in these two constituents, but is restrained from coming to the upper layers where plants have light enough to grow owing to the greater density of the deep water. Where however this deep water is brought to the surface by currents, minute plants and animals are abundant. By reflecting the rays of white and yellowish light they give the sea a green hue, whereas the barren areas of the ocean are a deep blue when viewed from above.

In the waters around our coasts, cooling of the surface in winter causes mixing with the bottom water, and as plant life is sparse during these months owing to lack of light the water becomes rich in phosphates and nitrates mostly from the decay of dead organisms lying on the bottom. In March-April, when the daily sunlight reaches about three hours per day, a rich outburst of diatoms utilises these salts in the water, starting from near the surface and proceeding downwards; in the late summer a second outburst of plant life occurs, utilising the nitrates and phosphates regenerated from the corpses of the spring and early summer growth of plants and small animals.

Mr. J. T. SAUNDERS.—*Environment and Behaviour.*

This paper deals with changes in the behaviour of certain ciliate protozoa in response to very small changes in the environment. The diurnal vertical movements of *Spirostomum* in small ponds may be maintained indefinitely in aquaria if the bottom

water is slightly more acid (or less alkaline) than the surface. When the pH of the aquarium water is uniform these movements cease. Aggregations of *Colpidium* and *Paramecium* in cultures can be completely controlled by varying slightly the pH of the culture. Slight changes in the pH of the culture also materially affect the powers of these ciliates to ingest food. If a layer of distilled water be placed over some culture fluid containing *Paramecium* in a test tube the *Paramecium* can be made to rise into the distilled water or not by slightly varying the pH of the culture fluid. If the pH of the culture fluid is adjusted so that the *Paramecium* are just able to rise from it into the distilled water, they can be prevented from rising by adding a trace of Mg (1 in 100,000) to the distilled water. The pH of the culture fluid controls this sensitivity to Mg and other cations.

Prof. W. GARSTANG.—*The Origin of Appendicularians.*

Mr. J. R. BRUCE.—*Physical Factors on the Sandy Beach.*

The complexity of the distributional and other responses of shore-living organisms points to their being the integrated result of many variable factors operating independently. The measurement and recording of such factors is an essential preliminary to a general ecological survey of the littoral fauna and flora.

No region of the seashore—possibly no other region of the entire biosphere—is subject to such frequent and far-reaching fluctuations as the sandy beach, and in this paper an attempt is made to indicate the nature and range of some of the more important factors operative in that region.

The dominant influence is undoubtedly the tidal rhythm, every other factor—temperature, salinity, oxygen-pressure, hydrogen-ion concentration, &c.—undergoing a semidiurnal change with the advance and return of the tidal flow. The effects of this major rhythm may be profoundly modified, however, by variable factors of longer period, both daily and seasonal, including meteorological changes, and the composition of the sea-water itself. In addition to these, numerous non-periodic factors are to be reckoned with, including the effect of fresh-water draining from the land, variations of grain-size or 'grade,' with corresponding differences in retentive and adsorptive capacity, lithological differences in the sand-substance, and the varying proportion of organic detritus due, in most cases, to the very organisms whose physical environment we are studying.

Mr. C. F. HICKLING.—*Dogfish in the Faroe-Shetland Channel.*

In the Faroe-Shetland Channel it was noticed that, in very deep water, all specimens of the dogfish *Acanthias vulgaris* taken in the trawl were males, whereas in shallow water females predominated.

Now the liver in the female dogfish is much larger, proportionately, than that of the male, and is also proportionately lighter; it must therefore tend to act as an organ of flotation, so that a female dogfish will require less effort to maintain its level in the water than a male. If one can assume that, in the dogfish, there are periods of diminished activity, such as after heavy feeding, the males will tend to sink to the bottom more readily than the females, and will therefore tend to predominate in hauls made in deeper water. This theory accords with the fact that pregnant females, which are heavy owing to the large eggs and developing young, are found to a much greater extent in deeper than in shallower water.

It is suggested that in bathypelagic fish, such as the dogfish, the varying sex-ratios found at different depths are due, in part, to a mechanical separation due to differences in specific gravity.

Prof. A. E. CAMERON.—*The Experimental Removal of Graber's Organ in Tabanid Fly Larvæ.*

By reason of its comparatively large size, Graber's organ lends itself admirably to experimental treatment, and as its true function has not been definitely determined it was thought that any modification in the behaviour of the larva following the extirpation of the organ might shed some light on this question. The chitinous, cystoid, pyriform organ is invariably found in the eighth abdominal segment, and contains a variable number of black, pedunculated, globular bodies. It possesses its own system

of muscles, by the contraction of which it is kept in almost continual oscillation in the living larva.

Graber in 1878 attributed to the organ the function of an otocyst, to which it bears a general similarity. Later investigators argued that it was either a gland or a sound-producing organ, but neither of these latter contentions can be readily accepted.

In twenty anæsthetised larvæ belonging to four distinct terrestrial species of *Tabanus*, the organ was successfully excised. On recovering from the effects of the anæsthetic the larvæ fed regularly, moulted and even pupated, producing in two instances perfect adults. In no case was the organ regenerated at a subsequent ecdysis. After the operation the larvæ responded to a variety of stimuli just as readily as they did before the organ was removed, and no lack of co-ordination was discernible. On this evidence Graber's organ is not a mechanism for the regulation of the organism's movements, an attribute commonly associated with otocysts. It may, however, serve to detect disturbances in the surrounding medium, and in this respect would serve a useful purpose both in free-swimming and terrestrial tabanid larvæ.

Friday, September 2.

Miss S. M. MANTON.—*On the Embryology of a Mysid Crustacean.*

Only a few points of more general interest can be considered. The germ layers and genital rudiment are differentiated externally on the germinal disk prior to gastrulation. The spatial relations of the germ layers in the Malacostraca are fundamentally different from the lower Crustacea in both yolky and non-yolky forms.

The mesoderm is formed in three ways. There are preantennular and seventh abdominal somites, and cœlomic cavities appear in most segments. The walls of the preantennular cœlomic sacs form the stomodœal musculature and anterior aorta just as in *Limulus* and Spider. Paired mesodermal bands in the 'naupliar' segments never contain cavities other than the antennal gland end sac. The whole antennal gland is mesodermal. The trunk mesoderm is formed by a row of eight teloblasts. Paired cœlomic cavities occur in all but the maxillary segment. A dorsal vessel is developed from the cœlomic sacs much as in *Estheria*; and a 'cardiac plug' is formed as in *Chirocephalus*. The seventh mesodermal somites lie behind the sixth segment which bears the uropods.

The endoskeletal system is ectodermal, and consists of (1) hollow ectodermal intuckings of the nature of apodemes, and (2) transverse segmental bars which separate from the ectoderm forming median tendons of the mandibular adductor and trunk mesodermal muscles.

Much of the musculature is ectodermal in origin.

Prof. E. W. MACBRIDE, F.R.S.—*On the Heart of the Larva of the Sea-urchin (Echinus miliaris).*

The existence of a pulsating vesicle or 'heart' in Echinoderm larvæ has been asserted ever since the time of Metschnikoff, who described it in the larvæ of Sea-urchins in 1864. It was rediscovered and more exhaustively described by Bury in 1889 and again in 1896.

A similar vesicle was described by Gemmell in the larvæ of starfish in 1912, and subsequently in those of Ophiurids in 1916.

In the course of experiments made with a view to modifying the normal course of development I have reared the larvæ of *Echinus miliaris* through the entire course of their larval development until the conclusion of metamorphosis every spring for the last fifteen years.

The larvæ of this species are peculiarly transparent, and so are well adapted to show their internal structure when living.

The pulsating vesicle can be made out in a larva about a fortnight old; but it is best observed just prior to metamorphosis. It lies above the œsophagus just under the madreporic pore.

The wall of the vesicle is the ventral wall of the dorsal sac; the contents of the vesicle are blastocœlic fluid contained between this wall and œsophageal epithelium.

The 'beating' is a wriggling forwardly directed peristalsis which must drive the contents forward. It is apparently dependent on a good oxygen supply, for if a larva be confined in a hollowed slide under a coverslip peristalsis occurs only at long

intervals (about once a minute), but in a larva taken from a vigorous culture and examined immediately it may occur forty times a minute.

The dorsal sac is derived from the posterior tip of the right anterior cœlomic sac; it has the origin and the position of the so-called pericardium in *Balanoglossus*. The heart of *Balanoglossus* is like that of *Echinus*, a blastocœlic space contained between the ventral wall of the pericardium and the dorsal wall of the œsophagus. Peristalsis, as in *Echinus*, is directed forward. This pulsating vesicle is already developed in the Tomana larva and affords another proof of the homology of the Tomana and Echinoderm larvæ.

Lt.-Col. the Right Hon. Sir MATTHEW NATHAN, P.C., G.C.M.G., Sir T. W. EDGEWORTH DAVID, K.B.E., C.M.G., D.S.O., F.R.S., Mr. F. A. POTTS, and Dr. C. M. YONGE.—*The 1928 Great Barrier Reef Expedition.*

Sir M. NATHAN.—Prior to 1922 inquiries with regard to the reef in its various scientific aspects suffered from want of continuity and of correlation; in that year a committee of Australian scientists was formed to secure continuous and related investigations; under their direction some physiographical and geological work has been done; owing to want of trained biological investigators and to other reasons, biological inquiry of a systematic and comprehensive nature has not yet been started; and the Australian Committee is hoping to get such a start made by British investigators with Australian assistance. The keeping of continuous records of biological interest and possibly even the establishment on a permanent basis of a Marine Biological Station in the south-western Pacific may, it is thought, be the ultimate result of such an expedition.

Sir EDGEWORTH DAVID, in stressing the importance of sending a well-found zoological expedition to work on the Great Barrier Reef of Australia, emphasises (1) the need for determining the existing bathymetric life zones in the present reef for comparison with the zones in the core from the recent diamond drill bore through the reef, near Cairns, in Queensland; (2) the general scientific importance of further exploring the Great Barrier Reef, especially from the point of view of the recently advanced theory of the post-glacial origin of existing coral reefs throughout the world.

Mr. J. GRAY.—*The Evolution of the Vertebrates from an Experimental Point of View.*

The course of evolution must have conformed to the principle of physiological continuity of function as well as to morphological continuity of structure. The bearing of experimental methods on such problems is illustrated by the data derived from the eggs of aquatic and terrestrial vertebrates.

The transition from aquatic to completely terrestrial life can only have occurred in those forms which were physiologically equipped with a mechanism for providing the embryo with an adequate supply of water. One half of the weight of a newly hatched fish consists of water derived from the external environment; more than a half of the water in a newly hatched chick is derived from the albumen. These facts suggest that the Amniota are to be derived from a form whose egg was similar to those of modern Dipriocus or Amphibia in that it possessed a tertiary gelatinous capsule. This capsule was primitively of a protective function, but was utilised as a reservoir of water as soon as the eggs were laid on land. The modern Amphibia provide a series of types whose eggs are physiologically intermediate between those of a typical fish and those of a typical Reptile. The reserve of water in Monotreme eggs is of a different type from that of Reptiles, and in the reduction of the albumen layer the egg foreshadows that of Eutherian mammals.

Mr. C. F. A. PANTIN.—*Movement in Amœba.*

Although Amœbæ may be considered degenerate rather than primitive, yet in their movement they exhibit the most generalised form of contractility to be found. There is a great variety of types of amœboid movement, but they all agree in that, unlike muscle and cilia, the amœboid individual possesses no permanently differentiated contractile structures.

It is important to determine the class of physical phenomena to which amoeboid movement belongs. Crude analogies suggested that a moving amoeba was comparable with a fluid drop in which the surface tension is lowered at one point. Microdissection and other evidence show this view to be untenable, and that movement is associated with the ready changes of state of the protoplasm from a fluid 'sol' to a contractile, solid 'gel' and *vice versa*.

These changes are most easily observed in the 'Limax' type of amoeba, in which it can be seen that each particle of protoplasm undergoes a more or less rhythmic change of state, sol=gel.

A physiological study of the amoeba shows that in the effect of temperature and of salts there is abundant evidence that the mechanism of movement is identical with that in the contracting muscle fibre.

During the course of evolution it seems that fundamental physiological systems such as the processes involved in contractility have remained unchanged, although the structures in which contractility occurs have undergone great morphological changes.

Afternoon Meeting in the Department of Textile Industries in the University of Leeds. Exhibit and papers by Dr. F. W. DRY and Prof. A. F. BARKER. (See p. 414.)

Monday, September 5.

Dr. A. J. GROVE.—*The Passage of the Spermatozoa into the Cocoon in the Brandling Worm, Eisenia foetida (Sav.)*.

In the account which has been given of the process of cocoon deposition in this worm it was shown that the eggs pass back from the apertures of the oviducts to the cocoon while the latter is still surrounding the clitellum, but it could not be determined at that time how the spermatozoa entered.

In sections through the albumen of cocoons fixed some short time after deposition, spermatozoa are found lying in varying positions indicative of a condition of inactivity following upon failure to enter an egg. In the albumen of cocoons dissected from around the clitellum just prior to deposition no spermatozoa could be detected. In freshly deposited cocoons spermatozoa are to be found surrounding the eggs but not actually penetrating the vitelline membrane. The outline of these spermatozoa is sinuous, indicating that they were actively swimming at the time of killing.

The evidence obtained supports the view that, although the eggs are passed back into the cocoon while the latter is still surrounding the clitellum, the spermatozoa enter during the passage of the cocoon over the apertures of the spermathecae. This difference in the method by which the two reproductive elements enter the cocoon is associated with the posterior position of the clitellum so characteristic of the *Lumbricidae*.

Mr. ARTHUR M. BANTA and Mr. L. A. BROWN.—*Sex in Cladocera as controlled by Environment*.

The paper (after a very brief statement of the necessary essential descriptive facts) treats the following topics as relating to *Moina macrocopa*: (1) Occurrence of males in nature. Data showing the production of males in experimental cultures (2) by crowding the mothers (accumulation of excretory products), (3) by low temperatures, (4) by chloretone and other chemical treatments; (5) the lowered rate of development of the mother as associated with these treatments; (6) means of restoring the rate of development to normal and thus preventing male production by mothers whose sisters, without the secondary treatment, produce males; (7) comparison of times of egg-laying of eggs destined to become females and those becoming males; (8) rate of development of embryos of the two sexes; (9) the clear-cut association of male production with lower rate of development and of female production with the normal rate of development; (10) relation of results of this study to other results on sex control.

Dr. F. A. E. CREW.—*Studies on the Thyroid.*

(a) *The Hairless Mouse.*

A new mutation 'hairless' in the mouse is described. This character is a recessive. The coat is developed normally, but is shed when the mouse is about three weeks old. The hairless male is fecund, the hairless female is infecund and her thyroid is definitely abnormal in histological structure. When the hairless female is kept at a temperature of around 30° C., however, she is fecund, and matings yield offspring.

(b) *Thyroidectomy in the Hen-feathered Cock.*

Hen-feathered Campine cocks after the removal of the thyroid become cock-feathered. The bearing of this fact upon the physiology and genetics of plumage characters is discussed.

Mr. D. WARD CUTLER and Mr. L. M. CRUMP.—*The Effect of Food Supply on the Multiplication of Protozoa.*

The effect of both quality and quantity of food upon the organism has been the subject of considerable study in many groups of animals. Among the protozoa it has been shown that in the case of a holozoic ciliate, *Colpidium colpoda*, there is a very definite relation between the number of bacteria supplied to a culture and the rate of production of the Colpidia. Among the Amœbæ the same relation holds good in *Hartmanella hyalina*, and in this case it has also been shown that the variety of bacterium used has a marked influence on growth and reproduction, certain varieties having a high and others a low nutritive value.

Mr. G. P. WELLS.—*The Action of Potassium on Contractile Tissues.*

Although very similar in their chemical properties, Sodium and Potassium have widely different physiological actions. Experiments illustrating the action of Potassium on the tone of muscle-preparations from Gasteropods (*Helix* and *Aplysia*) and Decapod Crustaceans (*Maia* and *Cancer*) are described; in both cases, as in Mammalian plain muscle, there is augmentation of tone if Potassium is either withdrawn or greatly increased above its normal concentration. Certain possible mechanisms of the specific effects of Potassium are discussed. The fact that in *Aplysia* the characteristic effects of Potassium can also be produced by the Ammonium ion suggests that the secret of Potassium specificity lies in a property such as ionic mobility, and excludes radioactivity from being a possible cause.

Prof. R. DOUGLAS LAURIE.—*The Position of Biology in the School Curriculum.*

Some study of biology should be included as an integral part of the education of every boy and girl.

It is of first importance to consider the scope and treatment of the subject for children of the 12–16-year group, the great majority of whom are preparing for citizenship without thought of going through the universities. It should be regarded as thoroughly bad to divorce from each other the study of animals and plants at this stage.

Biology which does not include plants fails to cover adequately the relation of the living to the non-living world; without animals it fails in its human significance as a foundation for hygiene, human physiology, and social science. This has been realised in other countries much more than in our own. The common fallacy that animals lend themselves less readily than plants to simple physiological experiment has been exploded.

It is suggested that in girls' schools botany, now so prevalent, should be converted into biology, and that botanists and zoologists should unite in claiming for biology the place due to it in the time-table of boys' schools. The movement in girls' schools has already begun; it may be anticipated that the slower movement to be expected in boys' schools will not be long delayed. The chief difficulty is the lack of qualified teachers, particularly for boys' schools, a lack to which more than one recent Government report has called attention.

Equipment is a relatively simple affair.

The general principles to be borne in mind in the arrangement of a course of biology for school children from twelve to sixteen years of age, as suggested in a recently published memorandum drawn up by a joint committee of teachers in schools and universities, are brought before the meeting for discussion.

Mr. H. N. RIDLEY.—*Fifteen Years in a Tropical Zoological Garden.*

The menagerie of Singapore Botanic Gardens was based on a small nucleus of animals which the author found there in 1888 when he took charge of the Gardens. These were increased until at various times there was a collection of almost all the most remarkable mammals, birds and reptiles of the Malay region. Not only attractive to visitors, the collection gave an opportunity of observing the habits and life-histories of many animals of which little was known; accounts are given of observations on the most interesting ones. Among these are the Anthropoid Apes, the Mias (*Simia satyrus*) and the Gibbon (*Hylobates agilis*) and its remarkable singing powers; the defence of the feeble Slow Loris (*Nycticebus*) by its poisonous bite; the habits, language and life-history of the smaller monkeys (*Macacus*); the liquid blood requirements of the tiger, the cause of its ferocious attacks on human beings and cattle; the cryptic colouring of the tapir both in young and adult pelage, the feeding of this animal and the rhinoceros and other forest ungulates as of importance in the dispersal of tree-seeds in the forests; and some account of the methods of capture of prey by the larger serpents is also given.

Tuesday, September 6.

Dr. KATHLEEN E. CARPENTER.—*On the Survival of some Ice-age Relics in the Freshwater Fauna of Cardiganshire.*

The Turbellaria-Tricladida of the Aberystwyth area include three species of particular interest: of these, *Planaria albissima* Vejd., hitherto known only from Bohemia, is remarkably abundant in this area. Two others, *Planaria alpina* (Dana) and *Polycelis cornuta* (Johnson), are well known on the European Continent as glacial relicts, surviving on the high Alps and sporadically in the cold stenothermic waters of mountain brooks in the Taunus, Harz, Eifel, &c. Both species occur in Cardiganshire streams as low as the tidal limit, and neither has been found on the high plateau above 1,250 feet. These apparent anomalies are to be understood with reference on the one hand to the geological history of the area, on the other to modifications in physiology and habit whereby the life-cycle is adapted to withstand a temperate climate.

Mr. E. PERCIVAL and Mr. H. WHITEHEAD.—*Methods for the Quantitative Examination of the Fauna of Some Types of Stream Bed.*

Nature of stream bed—stones without plants in rapid current, stones with moss and with filamentous algæ, beds with phanerogams, gravel. Definite areas sampled. The material is sieved, genera and species determined where possible and individuals counted. From the data obtained it is possible to determine the density of the population, the actual and the relative occurrence of species and the constitution of the fauna in each sample. It has been found that the density of the population varies largely with the nature of the substratum. Greater numbers occur with plant growth; smallest numbers are found among stones liable to movement and among bare stones. The presence of fine deposit on stones is correlated with an increase in number and variety of population.

Analyses of samples show the insect fauna in the regions examined generally to constitute more than 50 per cent. of the total. Of these the Diptera, mainly Chironomidae, are the most widely distributed and most abundant organisms. The Trichoptera and Ephemeroptera together equal the Diptera in number. Oligochaeta come next in abundance to the insects, and the Mollusca follow. The main mass of the bottom population is vegetarian.

Mr. J. W. TAYLOR.—*Upon the Geographical Range of the Mollusca and other Organisms and the Causes influencing their Dispersal.*

The dispersion of life over the globe is not an erratic and irregular process, or due to chance, but is governed by laws which are applicable to every form of life. A

study of these laws shows that dispersion is due to the more rapid advancement within the Western Palearctic region of improvements in organisation, this region being the theatre of the highest developments of the various forms of life in the world, and consequently there exists a more or less regular decrease of dominating power and organisation as we proceed therefrom; and confirms the region as that of the greatest evolutionary force, the forms arising there being superior to those of every other region, and therefore of invading and overrunning the neighbouring territories and dispossessing the previous occupant, and this is shown to be equally true not only for the Mollusca but for Mankind, Birds, Earthworms, Spiders, Plants, Fungi, Diatoms, Desmids, &c., and emphasises the improbability of world-diffusion from the Antarctic or other centres as is sometimes advocated.

The routes of dispersal from Europe of the dispossessed species have been determined by the correlation of a large number of facts gleaned from many sources, and are shown to be largely influenced by physical features, and that the areas now occupied, considered in relation to the evolutionary area, form an index to their position in the scale of life, as is confirmed by geological evidence and by the distribution of the Mollusca in time and space and supported by that of Mankind, Birds and other organisms displaying the intimate and indissoluble connection with Evolution and Phylogeny.

Prof. E. E. PRINCE.—*The Pectoral Fin in the Mackerel Sharks; Skeletal Contrasts in Isurus and Lamna.*

Prof. E. E. PRINCE.—*The Canadian Land-locked Salmon or Ouananiche.*

Dr. J. W. MUNRO.—*The Needs of Economic Entomology.*

With increasing specialisation in agricultural and forest entomology there has been a tendency to regard economic entomology as a branch of plant pathology or of agriculture or forestry and its zoological basis has been neglected.

While much can be done to control insect outbreaks by improved methods of cultivation, by selection of immune or relatively immune crop varieties and by such mechanical means as spraying and dusting, there is a real need for work on insects as such. In the solving of many insect problems progress depends on a fuller knowledge of insect morphology and physiology.

What is needed is a fuller recognition both by zoologists and by growers and manufacturers, who suffer from insect depredations, of the vast field still to be explored in economic entomology and of the varied nature of the work to be done. Economic entomology has need both of those who are interested in industry and the application of science to industry and of those who are interested in research. Until both groups of workers work in harmony progress will be slow, but by co-operation both groups of workers will benefit. It is, however, for the zoologists to show the way.

Afternoon Excursion to Washburn Valley.

EXHIBITS.

The Rev. Dr. S. G. BRADE-BIRKS.—*Recent Progress in our Study of British Diplopoda (Millipedes) and Chilopoda (Centipedes).*

Millipedes and Centipedes; especially recent progress in the study of British forms.

The following subjects are included:—

(A) Recent contributions of the continental workers Attems, Brolemann, Lohmander, Schubart, and Verhoeff to our knowledge of groups and forms occurring in the British Isles.

(i) Attems (1926), 'Progoneata. Chilopoda,' in *Handbuch der Zoologie*, IV Band (Berlin and Leipzig: Gruyter), reviews the classification of Diplopoda and Chilopoda. The application of his conclusions to British forms is illustrated by specimens and diagrams.

(ii) Brolemann (1923), 'Blaniulidæ,' *Arch. de Zool. exp. et gén.* **61**, 99–453, includes an account of British forms which are exhibited.

(iii) Lohmander in Sweden and Schubart in Germany have recently thrown light upon certain nomenclatural questions. Their conclusions are illustrated by micro-preparations and other specimens.

(iv) Verhoeff (1926), 'Fossile Diplopoden,' in his account of Diplopoda in Bronn's *Tier-Reichs*, deals with the structure of the sternites in Archipolypoda. British specimens of Archipolypoda are exhibited to illustrate various interpretations of the features observed, and preparations of recent Diplopoda are added for comparison.

(B) The fossil genus *Kampecaris*. A series of specimens and preparations for the comparison of this genus with recent Millipedes.

(C) *Brachydesmus* and *Polydesmus*; *Iulidæ*: comparisons illustrating the principles of elongation and contraction in phylogeny and ontogeny.

(D) The economic status of Millipedes and Centipedes in the British Isles.

DIPLOPODA associated with crops are to be regarded as injurious (e.g. *Brachydesmus superus*, *Blaniulus guttulatus*).

Among CHILOPODA, LITHOBIOMORPHA are to be ranged with the so-called beneficial insects. How far they are beneficial depends upon the habits of their prey; while certain GEOPHILOMORPHA, sometimes carnivorous, may on occasion prove to be a pest to crops.

SECTION E.—GEOGRAPHY.

(For references to the publication elsewhere of communications entered in the following list of transactions, see p. 432.)

Thursday, September 1.

Presidential Address by Dr. R. N. RUDMOSE BROWN, on *Some Problems of Polar Geography*. (See p. 75.)

Mr. J. M. WORDIE.—*Colonisation and Development in East Greenland*.

Attention is directed to the decision of the Danish authorities to establish Eskimo colonies on the east coast of Greenland in Scoresby Sound and northward between 70° and 75° N. lat. The colonies will be recruited from Angmagsalik (66° N.); and the first has already been established. When visited last summer it had just concluded a most successful season; and further developments are now certain.

The new settlements invite comparison with the story of former habitation shown by tent rings and winter houses found over the entire length of the east coast even up to 82° N. These remains indicate a flourishing people at a date prior to 1822. In that year Scoresby made the first landings in East Greenland in Scoresby Sound and on Traill Island, and found more than one village site, but all deserted. The next year Clavering, farther north, met a party of twelve in Gael Hamkes Bay. Apart from the latter discovery, no other living Eskimo are recorded on the east coast, until the discovery of Angmagsalik in 1884; this centre is much farther south, however, and should be described as on the south-east coast. The Eskimo of the more northern part had practically disappeared in Clavering's time, and their connection, if any, with Angmagsalik is doubtful.

Investigation of the remains shows a people living in much the same way as the Cape York or Polar Eskimo (Sir John Ross's Arctic Highlanders). No remains definitely assignable to the earlier Thule culture were found by the Cambridge party. Whether the Eskimo arrived on the east coast by a route round the north or round the south of Greenland is still open to question. The reason for their disappearance may be set down to changes in the distribution of game and behaviour of the pack ice—both ultimately due to changes of climate.

The question is raised whether the modern colonies have a chance to survive when the older natives were unable to do so. In the interval new factors have come in—firearms and the possibility of trading with the outside world—and it is confidently expected that the new development will be a success.

Dr. VAUGHAN CORNISH.—*On the Fixing of Linguistic Boundaries by National Adoption of Christianity between the Beginning of the Sixth and the End of the Fourteenth Centuries*.

The readjustment of political boundaries in Continental Europe following on the Great War has been for the most part in linguistic borderlands. In the course of an

examination of the historical geography of these districts, the author has found that, almost without exception, the present linguistic boundary is within a few miles of a former boundary of Christendom on the eve of the official conversion of the heathen country; an event which occurred as early as the sixth century in Western, and not later than the fourteenth in Eastern, Europe. Thus the boundary of Flemish and German with Walloon occupies the same position as at the time of adoption of Christianity by the Franks; that between German and French in Alsace-Lorraine marks the division between the Christian kingdom of Burgundy and the heathen Alamanns, afterwards converted; the Italian linguistic boundary in Tyrol that between the Christian kingdom of Lombardy and the heathen Bavarians; and in the former Duchy of Friuli approximately that between the Christian Lombards and Slavs before the conversion of the latter. The borderland of Greek language in Macedonia and Thrace marks the southern frontier of the Bulgarian empire at its official adoption of Christianity in the ninth century.

An infiltration of Germans among Czechs has gone on for a long time past, but the borderland of mixed language marks the limit of Bohemia at the time of conversion. There is little trace upon the present map of the former linguistic boundaries of the Slavs who remained heathen until after their conquest by the Germans, as in Brandenburg, but the borderland of mixed Polish and German speech approximately marks the position of the Poles at the time of their conversion in the tenth century. The boundary of Russian language with Polish, Latvian and Estonian occupies the same position as at the time of the adoption of Christianity by the Russians in the reign of Vladimir I (980-1015). Similar results have been worked out for other borderlands of European language where political reconstruction has occurred since the Great War.

The author calls attention to the light thrown upon problems of modern nationality by a study of the dioceses and archiepiscopal provinces of medieval Europe.

Lt.-Col. the Rt. Hon. Sir MATTHEW NATHAN, P.C., G.C.M.G.—*The Great Barrier Reef.*

While Darwin's theory of coral reefs growing up as the foundation on which they rest subsides, so that coral-beds of great thickness can be formed within those depths that are favourable to coral growth, is consistent with recent speculations as to the influence of isostasy and radio-activity in producing a series of earth surface revolutions creating mountain ranges and buckling the ocean bottom, neither these speculations nor Darwin's theory are universally accepted. The bearing on the latter of the results of borings in 1903 at Funa-futi, one of the Ellice Islands in the Pacific, and in 1925 on the Great Barrier Reef itself, are discussed in the paper, which gives a geographical description of the reef and of the neighbouring land and seas, explaining the factors that have limited coral growth to the north and south, and that have produced the high rocky inner and low coral outer islands on either side of the long lagoon that runs by the coast of Queensland. The recently observed crescentic formations and pinnacle growths on the inner reef are described, as well as the manner in which the loose coral growths are gradually compacted by filling and cementing, and the circumstances in which coral branches and masses are broken off, disrupted, and triturated. The paper concludes with some remarks on the zoological aspect of coral reefs in general, and of the Great Barrier Reef in particular, and on the economic results that may flow from a greater knowledge of life on this unique geographical structure.

Dr. BAILEY WILLIS.—*The Palestine Earthquake, July 11, 1927.*

Friday, September 2.

Papers on Studies in the Geography of Leeds, by members of the School of Geography of the University of Leeds:—

Dr. C. B. FAWCETT.—*The Position and Growth of Leeds.*

Leeds is a foothill town at the eastern edge of the Pennine Highland, on the largest of the valleys which open on to the Vale of York. It is also near the western

end of the morainic ridge across the Vale of York, and just within the northern edge of the coalfield. It appears first as an agricultural village in Domesday. Later it became a market town and a manorial borough. But not till the development of the woollen industry was it an important town. The location of this industry was fixed by the presence of the soft-water streams from the highland; and Leeds became its chief commercial focus when the Aire was made navigable up to Leeds Bridge. This waterway has been a primary factor in the growth of the city, and must be further developed if that growth is to be maintained. In land ways it is noted that before the growth of Leeds the trans-Pennine route was along Wharfedale, and the transfer of that route to Airedale is a result, rather than a cause, of the city's importance. The plan of the city is summarised and related to the natural features of the site.

Messrs. G. E. HILL and A. T. WHITAKER.—*Land Utilisation in South Leeds.*

A survey of a segment of the city from Leeds Bridge to the southern boundary shows three well-marked zones: (a) below 150 feet above O.D., on the valley bottom, is an area mainly devoted to heavy industry and transport working, with some slum housing; (b) above this, and extending half a mile beyond it, an area of better-class residences with few industrial buildings; (c) an outer zone of recent and better residential type which has developed only since the tramway made it accessible in 1901 and 1904. The steep slope overlooking Worthy Beck is still unbuilt on and is partly waste.

Mr. R. E. DICKINSON.—*Zones of Influence of Leeds.*

Returns have been obtained indicating the areas served or controlled from Leeds by head offices or Yorkshire district offices for many forms of activities, such as retail and wholesale provision and other merchants, the markets areas, insurance and other finance work. We have also mapped out the zones of accessibility from Leeds by train and bus, taking account of both time and frequency of services. From these and other evidences we map three zones of influence round the city. The outermost is the distinctive Yorkshire region, which extends from the North Sea to the Pennine watershed and has well-marked limits to north and south. To the north we find Cleveland, all the Tees Valley and Swaledale are under the influence of the Tyneside combination and not that of West Yorkshire. To south the frontier between the zones of influence of Leeds and Sheffield lies along the watershed between the Calder and Dearne Valleys. Within this wide region is the smaller area served daily from Leeds and some subdivisions as between Hull, York, Leeds and Bradford.

Mr. E. HEPWORTH.—*Castleford.*

Castleford is now a small urban district ten miles S.E. of Leeds at the confluence of the Aire and Calder. It was a Roman station on the Great North Road, and is now a colliery and manufacturing centre. But its position in the flood plain, and its overshadowing by the mediæval fortress town of Pontefract, only three miles away, and the earlier industrial growth of Leeds, have prevented any considerable growth.

AFTERNOON.

Excursion in the Leeds area.

Saturday, September 3.

Excursion to Middle Wharfedale, Skipton, and Nidderdale.

Monday, September 5.

Dr. JANSMA.—*Land Reclamation in Holland with Special Reference to the Zuiderzee.*

A Frenchman said: 'Dieu créa le monde, excepté les Pays-Bas qui furent créés par les Hollandais.' Indeed, a large part of Holland is so low that it lies below the

level of the sea. In the Middle Ages a considerable amount of land was flooded by the sea; in the seventeenth century the reclamation of 'polders' by means of wind-mills began; a number of lakes were drained. Between 1849 and 1852 Haarlem Lake, the last large one left, of about 44,000 acres, was drained. At the same time schemes of a much larger scope were published, viz. to drain the Zuiderzee. After careful consideration, a scheme proposed by Dr. C. Lely was sanctioned by the Dutch parliament in 1918, and is now being carried out. The result will be the reclamation of about 550,000 acres of excellent soil, or an increase of the arable part of Holland by about 10 per cent.

Sir GEORGE FORDHAM.—*Surveys and Maps of the Elizabethan Period remaining in manuscript—Saxton, Symonson and Norden.*

This paper is an attempt to gather up the work, other than that which has been perpetuated by the engraver's art, of three representative surveyors and cartographers who flourished during the last quarter of the sixteenth and the first of the seventeenth centuries—Christopher Saxton, Philip Symonson, and John Norden.

Saxton's activity in private practice as a surveyor seems to have been confined to a period of ten years, 1596-1606; his atlas of the countries of England and Wales having been completed in 1579, and his large scale map of England and Wales having been published about 1580. He surveyed Manchester in 1596, but this map cannot now be found. In the same year Saxton was a witness in proceedings as to boundaries in Lincolnshire, and in 1599 he was similarly engaged, as he was also in 1601 and 1606 in controversies as to water-rights, in all of which proceedings he prepared and certified plans. These plans are now in the Public Record Office. A plan of Dewsbury and of the River Calder above that town, by Saxton, is in the Dewsbury Free Library, and dated 1600.

Symonson is only known generally by his important map of Kent of 1596. He was superintendent and surveyor of the Rochester Bridge Estates from 1592 until his death in 1598. During his term of office he surveyed and mapped four of the estates, the property of the Bridge Wardens, and three of these maps still exist among the archives of this corporation. In art, appearance and colouring, they resemble closely the work of Saxton.

Norden's work in estate survey is much more instructive from the point of view of the history of cartography in England than that of either of his contemporaries. In 1600-1601 he made an elaborate survey, drawn in twenty-eight large sheets, of the estates of Sir Michael Stanhope in and around Orford, on the coast of Suffolk. These maps are now in two sections, following a division of the original estate, of which one (maps I to X) is in Woodbridge, in the office of Mr. Ernest Wood, solicitor, and the other (maps XI to XXVIII—except XIII, which is missing) is in the Sudbourne Estate Office, at Chillesford Lodge, near Orford. This series is of uniform appearance and detail, and is drawn in bright colours on vellum sheets measuring about 528 mm. in height by 722 mm. in width. It is a work of considerable cartographical importance, and geographically is interesting for the delineation of a long length of coast line, since 1600 subject to alteration and erosion. The total acreage mapped is about 15,000.

Norden's next important work was a survey of the Honor of Windsor, with the Castle and all the forests, walks, parks, &c., and details of the head of deer in each. This is of 1601 and is on seventeen sheets of vellum, drawn in colours and gilded. Two copies are known, that made for the king (James I) is in the British Museum (Harleian MS.), and a duplicate made for Henry, Prince of Wales, has been lately acquired by the Royal Library at Windsor Castle.

A further important work was confided to Norden at this period, that of a complete survey of the manors and property of the Duchy of Cornwall in the West of England, made in the years 1609 to 1616. This also is now at Windsor, having been recently presented to the King by Lord Verulam from the Gorbambury Library. It has, however, but a few sketch maps, and is generally the written record of inquiries relating to the estates, and summaries of the particulars thus obtained, made up into two quarto volumes. It is obviously only of collateral interest in connection with the present subject.

The paper deals fully with the maps and plans enumerated above, which are, especially those of Norden, instructive as illustrating the progress achieved in the reign of Elizabeth in the art and practice of survey and map construction. Few such maps, whatever may have been their original number, have survived to the present

time, and those here described can certainly be regarded as typical of their period. It is possible, and it is hoped, that the publication of this study may lead to the discovery of other similar estate plans of early date now buried in public and private depositories.

Mr. J. H. REYNOLDS.—*Iceland.*

AFTERNOON.

Excursion to Otley Chevin, Lower Wharfedale and Adel.

Tuesday, September 6.

Mr. G. N. HUMPHREYS.—*Ruwenzori.*

The legendary source of the Nile in snow mountains, the rediscovery of such mountains by Stanley and the British Museum Expedition and that of the Duke of the Abruzzi in 1906, brought the Ruwenzori Mountains at that time much to public notice. During the following twenty years, however, no fresh ground was broken in the range and no peak reclaimed. Last year exploration was continued by two expeditions. The former of these climbed some new peaks and crossed the range through the largest unknown area, making the first crossing of the mountains via the snows. Three lakes were discovered, two of them larger than lakes previously found in the range. The latter expedition climbed several new peaks and reclaimed the highest peaks of the four largest snow mountains, including the highest point in the range. Exploration was handicapped during the former expedition by the desertion of the porters and during both expeditions by bad weather, which obtained during the two and a half months spent in the mountains.

Miss A. GARNETT.—*The Capitals of Morocco.*

The major geographical factors underlying the historical and political importance of the present capitals, their relation to lines of expansion and invasion of the Moorish Empire via the Atlas passes and S. Riffian highway.

Marrakesh as an oasis centre; a 'crossroad' and 'storehouse' site for invaders from the west Sahara; a 'forward' position for sixteenth-century expansion southward to the Sudan.

Fez and Mequinez as 'crossroad' sites at the western terminus of the great E.-W. Barbary highway. The early historical importance of this region.

The geographical division of the empire into the dual kingdoms of Fez and Marrakesh when politically weak; and greater domination of Fez when politically strong.

Rabat as the capital of the French Protectorate: its value as a coastal capital in comparison with the inland capitals, in relation to present economic and political conditions.

Dr. S. E. J. BEST.—*Wheat Cultivation in relation to Soil Types on the Yorkshire Wolds.*

The soil above the chalk on the Yorkshire Wolds is generally very thin, often being not more than six inches in depth. A map constructed from the Parish Returns of the Ministry of Agriculture showing the distribution of wheat in the East Riding shows a greater concentration than would be expected on the eastern flanks of the Wolds. When a line is drawn showing the westward limit of this concentration—a 'wheat line'—it is found to be higher up the sides of the Wolds than is the boulder clay mapped by the Geological Survey.

Reference made to Kendall's work on the glaciation of Yorkshire shows that the 'Wheat Line' almost coincides with his probable maximum limit of ice up the eastern sides of the Wolds.

The inference is that there are in this area patches of boulder clay and glacial detritus neither deep nor constant enough to be mapped, but still of sufficient importance to be regarded as constituting a definite and distinctive Soil Region, different

from the chalk area to the west and the boulder clay area to the east. This is corroborated by personal investigation and by work on the distribution of crops and of population.

Wednesday, September 7.

Miss S. HARRIS.—*Village Settlements in the Channel Islands.*

(I) The 'natural' control of settlement in the Channel Islands the same in each island. Human groups moved up valleys to fertile patches on plateaux, focussing round sites of prehistoric importance (later, sites of parish churches).

(II) Meitzen (German school) divides settlements in N.W. Europe into (1) Einzelhöfe, single farms, (2) Dörfer, compact villages; and places the Channel Islands in the former group, with Jersey as a special example. His map is too generalised a statement of facts.

(III) Channel Islands show grouped homesteads, open fields with ownership of scattered strips, communal organisation, banon (rights of stubble pasture), inalienable rights of grazing on the waste, one-field rotation. This is not pure Einzelhof.

(IV) Einzelhöfe of e.g. (a) Westphalia, (b) North Sea coastal lands, were modified by introduction of 'Esch' (common arable); and in (b) a one-field system obtained. Settlers from (b) colonised Kent and introduced tenure by 'gavel-kind.' Settlements in Channel Islands and Kent very similar and probably the same in origin.

Mr. H. KING.—*A Geographical Study of a Yorkshire Manor.*

Mr. R. P. BRADY.—*Rural Settlements in the Middle Trent Valley.*

The relation of the area to the Midlands—its 'confluence' feature. The surface geology and its relation to relief and the main rivers. The distribution and types of village in relation to these. The riverside type—the gravel terrace type—the hillside type—the valley type of the lower Trias.

Examination of the types by characteristic examples. Their sites analysed and their typical developments noted. The riverside villages from Willington to Swarkestone; the gravel villages of Weston and Aston; the spur villages of Mickleover and Littleover; the townships of Repton and Donnington. Some changes in value of the sites due to changing lines of communication.

SECTION F.

ECONOMIC SCIENCE AND STATISTICS.

(Communications on Textiles, received at special sessions, will be found on p. 411.)

(For references to the publication elsewhere of communications entered in the following list of transactions, see p. 432.)

Thursday, September 1.

Mr. T. S. ASHTON.—*The Coalminers of the Eighteenth Century.*

In Scotland, until 1775, the colliers were bound in lifelong servitude; and, before and after emancipation, the family was the labour unit. In the North of England a yearly hiring was general, under bonds made between individual colliers and their employers. South of the Tees the hiring period was much shorter, and the economic unit was a co-operative group of workers represented in bargaining by a leader or charter-master.

Between 1700 and 1780 money wages remained constant, and food prices varied widely with the harvests, and in the industrial disturbances, which commonly occurred in years of shortage, animosity was directed, not against the employers, but against the dealers in grain. After 1780 wages showed more flexibility, and industrial disputes of the modern type took the place of food riots.

Some migration of labour occurred between the coalfields, but there was little recruiting from other industries, and wages were maintained at a relatively high

level. In spite of physical and spiritual isolation the mining population occasionally threw up men of talent. After 1815 an influx of outside labour was perhaps responsible for some fall of economic standards; and too rapid development may explain some of the conditions revealed in the reports of the 'forties.

Presidential Address by Prof. D. H. MACGREGOR on *Rationalisation of Industry*. (See p. 98.)

Friday, September 2.

Prof. J. SCHUMPETER.—*The Instability of our Economic System.*

In what sense can our economic system be said to contain possible causes of instability?

Dr. P. SARGANT FLORENCE.—*Fallacies and Pitfalls of non-Statistical Economics.*

(1) Economics assumes certain 'principles,' such as the principle of substitution and the notion that all incomes except rent are remuneration for real costs in effort and sacrifice, and assumes also certain conditions such as occupational mobility, competition, business acumen, knowledge of trade opportunities and the stationary state.

(2) These assumptions are only gradually and grudgingly modified by a process of 'disabstraction' to approximate to the observed conditions and ways of human behaviour which are variegated, changeable, uncertain and juxtaposed in unexpected combinations. When applied to interpret any particular situation this deductive method, though a corrective of many popular and bourgeois fallacies, is prone to lead to the 'fallacy of accident' and the pitfalls of dogmatism and fatuity.

(3) Strict economic generalisations are blind to the implications of such statistically measurable 'accidents' as the skew distribution of incomes, or the variety of automatic and deliberate methods of fixing price and production, or the variation of opportunity and mentality among actual and potential entrepreneurs, or the vagaries of trade from industry to industry.

(4) Fallacies of *dogmatism* were frequent among the classical economists. To the admitted wage-fund fallacy may be added Senior's theory of output as an exact multiple of hours worked, and the iron law of wages that supposed a positive correlation of income and births per family.

(5) Warned by the positive fallacies of their predecessors, modern economists run in most danger of a fall into the pit of *fatuity*. They claim that their theories are true deductions from fixed principles and conditions 'other (independent) things being equal,' but make little attempt to test the existence of those conditions, to bring their principles into relation with the complicated welter of facts, or to find how far what 'other things' are ever equal or even independent.

(6) Statistical methods have been specially devised for the summary measurement of the variable and composite events displayed in human society. Is it possible to fuse in a 'statistical economics' statistics fidelity to facts with the tried faiths of economic theory? This fusion is certainly in line with the views of Marshall, Cassel and some of the modern American school.

(7) Statistical economics would first attempt (a) to select the units in which such events as an increased supply of 'labour' or increased productivity is to be reckoned, and (b) to define such economic characteristics and principles as specialisation, mobility, localisation, or over-population in measurable terms such as index numbers, ratios or co-efficients. This implies the use of the objective measuring rod of money or quanta as a starting-point rather than vague psychological components such as real costs and utility.

(8) How economic events and characteristics (e.g. rent) are supposed to be determined would be finally (c) set forth step by step as correlation theories or other definitely statistical issues; these issues to be argued, after expert inquiry 'in the field,' by statistical analysis in combination with such economic speculation as has stood the test of time.

Monday, September 5.

Mr. J. WEDGWOOD.—*Some Evidence Concerning the Influence of Inheritance on Distribution.*

Among the questions which require an answer, in assessing the relative importance of inheritance as a factor in distribution, are (1) What is the proportion of the aggregate property derived from inheritance? (2) What degree of correspondence is there between the inheritances and fresh accumulations of individuals? Lack of data on the subject. Inadequacy of official statistics and of millionaires' biographies. Analysis of a large number of individual cases required. Investigation of a sample at the English Probate Registry. An attempt to compare the fortunes of the hundred richest men dying in 1924-25 with those of their predecessors. Difficulties and limitations of the investigation. Results—high proportion of inherited wealth indicated as regards the aggregate; comparatively small proportion of 'self-made' men; correlation between size of fortunes of predecessors and successors. Review of chief trade interests and social status of predecessors. Miscellaneous results—*e.g.* average age at inheritance and length of the generation. Evidence from the Estate Duty statistics. Analysis of the figures relating to four pre-war and three post-war years shows that the relative distribution of property in England is remarkably similar among individuals at different ages, *i.e.* the nature and slope of the curve of distribution is much the same for all age-groups after thirty-five. This observation is significant, in view of the fact that the size of the average estate increases up to the most advanced age, and that the proportion of property acquired by saving must be greater among the relatively old; it indicates that the inherited wealth of individuals is a more important factor than is sometimes supposed in determining the extent of their subsequent accumulations.

Some observations on the question of the proportion of the aggregate capital of the United Kingdom inherited from previous generations.

Discussion on *The Recent Course of Prices* :

(a) Sir ALFRED YARROW.

The price of a commodity is its value measured in gold. The value of gold fluctuates like other commodities, dependent upon the cost of production and the supply and demand. Consequently, the price of a commodity varies with the value of gold and the value of the commodity exchanged for it.

The rapid development of the gold industry in the Transvaal since 1900 has brought into circulation a large increase in the supply of gold, and as much is obtained at the present time from the Transvaal as from all the rest of the world. This great addition in the supply of gold reduces its value, *i.e.* more gold is now required in exchange for the necessities of life and other commodities than formerly. This increase of price is proved by the fact that in 1913 eighty-five sovereigns were required to purchase commodities which in 1896 cost sixty sovereigns.

At the outbreak of war Treasury notes were printed and made legal tender.

When the credit of Great Britain began to decline Treasury notes were not taken at their face value, and in 1920 251 £1 notes were required to purchase what in 1896 cost sixty-one sovereigns. This enormous increase in price was mainly due to, firstly, the supply of gold from the Transvaal; secondly, the shortage of commodities owing to a large section of the population having been drawn away from producing in order to fight; thirdly, the reduced credit of this country. When the funding of the British debt to America was agreed upon the increase of price due to the depreciation of our paper currency gradually disappeared.

The rise in the cost of commodities from 85 in 1913 to 127 in 1926 is mainly due to the increase in the cost of production in this country caused by:—

1. Excessive taxation.
2. Reduced production due to strikes, lock-outs, &c.
3. The restrictions demanded by trade unions which diminish the output per man.
4. Unwise legislation, such as giving doles without work being done in exchange.

(b) Miss M. TAPPAN.—*Prices and Price-Control in Great Britain and the United States.*

Movements in general prices in Great Britain, 1890-1913; secular, seasonal and cyclical variations, with suggestions upon the possible inter-relations of these

movements. The movements of prices (*a*) in the steel industry, and (*b*) in the cotton industry, in relation to those of general prices. Movements in the prices of variable-income shares, and in short-money rates. Customary sequences in the movements of these several classes of prices and alterations in such sequences; their potential explanation.

Comparative movements in strictly similar classes of prices in the United States, 1890-1913, the problem of relative precedence in the movements of prices as between the two countries, and possible interpretations of certain apparent relations.

The movements of general prices in Great Britain and the United States in the post-war period. The extent of their control by central banks, as inferred from the inter-relations of prices in the markets for commodities, for securities and for money.

Tuesday, September 6.

Joint Discussion with Section J on *Innate Differences and Social Status*.

Introduced by (*a*) Dr. MORRIS GINSBERG.

(*b*) Prof. GODFREY THOMSON.

(*c*) Mr. F. C. BARTLETT.

Dr. GINSBERG.—The paper deals with the nature of the social classes and the differences in respect of physical and mental characters existing between them. The problem is to determine to what extent these differences are due to forms of social selection operating upon innate differences, and to what extent they are due to environmental influences. A critical study will be made of the evidence relating to (1) differences in physical characters, such as stature, cranial capacity, brain weight, &c.; (2) differences in intelligence as measured by mental tests and in other ways. The difficulties of disentangling the environmental from the innate factors will be stressed. It will be shown that only very tentative conclusions can be arrived at as yet. Considerable importance will be shown to attach to the problem of the extent of social mobility, and evidence bearing on this will be submitted based on (1) data derived from Prof. Bowley's studies on poverty, (2) a questionnaire specially designed for this purpose. The whole problem will be discussed in the light of what is known with regard to the laws of heredity in man and in the history of social differentiation.

Mr. A. W. ASHBY.—*The Economic Situation of Agriculture*.

Wednesday, September 7.

Mr. C. J. HAMILTON.—*The Theory of Co-partnership*.

(1) The capitalist system has hitherto exhibited certain characteristics which have exposed it to just criticism. Co-partnership is advanced as a remedy for some of these, and its adherent claim that it enables the essential advantages of capitalism to be reconciled with 'a socialised industry.'

(2) The expectations regarding co-partnership entertained fifty years ago have not been realised. It is now often said that the claims of co-partnership are fallacious, or that co-partnership is of very limited application.

(3) The term co-partnership has been used in two senses: a partnership between workers and a partnership between capital and labour. The latter interpretation now predominates.

(4) The supporters of co-partnership have commonly belonged to one of two schools. According to one view co-partnership is founded on the need for economic justice and goodwill. According to the others it is based on the need for a productive stimulus. Both schools have treated profit-sharing as an essential element. The justification for profit-sharing thus needs to be examined.

(5) Profit-sharing as a stimulus to productive effort. The nature of the stimulus differently conceived. This mode of rewarding it implies its partial application. It is said that 'profit-sharing is a form of exploitation.'

(6) Profit-sharing based on surplus. This raises the question of the reality of

surplus. Further, its determination implies that the risk rate is calculable. Finally it may be questioned whether surplus profits should be distributed.

(7) Contributory co-partnership may be distinguished from the two preceding schools. In itself it does not contain a complete theory.

(8) Conclusion as to the place of co-partnership in industry.

SECTION G.—ENGINEERING.

(Communications on Textiles, received at special sessions, will be found on p. 411.)

(For references to the publication elsewhere of communications entered in the following list of transactions, see p. 432.)

Thursday, September 1.

Presidential Address by Prof. Sir JAMES B. HENDERSON on *Invention as a Link in Scientific and Economic Progress*. (See p. 120.)

Papers on Lubrication :—

(a) DR. T. E. STANTON, C.B.E., F.R.S.—*The Lubrication of Surfaces under High Loads and Temperatures*.

The paper deals with experimental investigations carried out at the National Physical Laboratory for the purpose of determining the thickness and arc of contact of the oil film, and the nature of the frictional resistance of a cylindrical bearing when the load is increased up to the seizing point.

Apparatus for the measurement of the attitude and eccentricity of a cylindrical half bearing is described, and the results obtained are compared with those calculated from the theory. It is shown that the discrepancy between the observed and theoretical results for high values of the eccentricity is due to the pressure in the oil film at the extremity of the 'off' side of the bearing becoming negative, as indicated by the theory and the consequent drawing in of air into the space in the neighbourhood of the 'off' side with the result that the arc of contact rapidly diminishes.

This, it is concluded, is the condition which brings about seizure of the surfaces at loads considerably below those which would be expected from the theory.

Apparatus is also described for the determination of the values of the frictional resistance of the bearing as the temperature of the film is increased, and it is shown that for every lubricant there is a well-defined temperature of minimum friction and temperature of seizing.

The results of experiments with various lubricants are discussed, and it is shown that for bearings under very high pressures and temperatures the best performance is not necessarily given by lubricants having the least co-efficient of friction for surfaces in contact, *i.e.* under boundary lubrication conditions.

(b) Sir W. B. HARDY.

Followed by Discussion.

Prof. W. CRAMP.—*A Hydraulic Model illustrating the Behaviour of the Arc*.

The electric discharge, whether in the form of a spark, the current through a neon tube, an ordinary arc, or a vacuum arc lamp, has one characteristic which distinguishes it from conduction of other kinds. No current passes across the arc until a certain maximum pressure has been reached, but after this the current can be maintained by a very much lower p.d. In some cases, the slope of the p.d. current characteristic is negative; in others, as, for instance, the neon tube, it is positive. Special forms of discharge, such as the Poulsen arc, have a characteristic intermediate between that of the neon lamp and that of the ordinary arc. The fact that the discharge p.d. may be much lower after the current has once begun than at the time of breakdown, enables the discharge, in its various forms, to produce surges and oscillations, provided

that appropriate apparatus, such as resistances, condensers, and inductances are included in the circuit.

Since in a circuit consisting of a tube containing liquid resistance may be represented to some extent by fluid friction, inductance by mass, and capacity by storage, it follows that, if such a tube can be provided with apparatus which will allow of the free escape of liquid when a certain pressure is reached, and with a continuation of that escape at a lower pressure afterwards, the condition of the electrical discharge circuit may be imitated.

Such an arrangement entails the use of a valve, which will open at a predetermined pressure and remain open until a lower pressure has been reached. This is not easy to provide by mechanical means. It may, however, be arranged by making use of the phenomena of surface tension. If a siphon tube is made of gradually increasing diameter, the potential energy of the meniscus increases as the diameter increases, and consequently there will be a tendency for the meniscus to contract against the gravitational force of the liquid in the tube. If, therefore, the amount of liquid in the tube increases, the meniscus expands until a certain limit is reached, when it allows liquid to escape. This arrangement forms a very perfect automatic valve for the purpose of a model to imitate the electric discharge. Such a model has been made and will be shown. It is possible to imitate the production of electric oscillations by the Duddell arc, the behaviour of the neon lamp when fed from a constant pressure circuit with a resistance in series and condenser in shunt, and the behaviour of certain phases of the Poulsen arc, as confirmed by photographs taken of cathode ray oscillograms.

Friday, September 2.

Papers on Coal :—

(a) Dr. C. H. LANDER.—*Our available Coal Supplies and their Utilisation.*

(b) Prof. J. W. COBB.—*The Utilisation of our Coal Supplies.*

The author considers what are the factors at present limiting the applications of carbonisation or similar processes to the great bulk of our coal supplies, and what is being done or may be done to remove those limitations. Such processes entail a thermal and monetary expenditure. If they are to be justified it must be by the enhancement in value of the products sufficient to cover the cost.

The high thermal efficiency of carbonisation is pointed out, and the enhanced value of the heat unit in gas as compared with that in coal. The expenditure for installing and working plants for carbonisation is high compared with the appliances for the direct burning of coal, because the rate of combustion of coal in air is so very much more rapid than the reactions involved either in carbonisation or gasification. Hence the amount of work which is being done to speed up the working of processes in one way and another.

In carbonisation, apart from new designs of plant, studies are being made of the influence of temperature of working, size of coal, the effect of blending and carbonisation of very fine particles. These are discussed, and also the results obtained, when the behaviour of coal is modified by the introduction of small quantities of inorganic constituents, such as iron oxide, lime and soda. Greatly enhanced rates of gasification are so obtained with steam or carbon dioxide on the laboratory scale—reactions which underlie the processes of making water gas and producer gas on the industrial scale.

(c) Prof. R. V. WHEELER.—*The Chemistry of Coal.*

The materials, all forms of plant structures, that may have contributed to the composition of coal, are numerous and diverse in character. Except for certain specific substances, too small in amount to require consideration here, these materials are, however, substantially the same in chemical nature, though varying widely in form and in the relative quantities present, whatever the type of plant life to which they belong. The relative amounts of the different plant materials that ultimately form coal may be considerably altered by the conditions of their accumulation in the coal-forming beds. There will, for example, be a tendency for the heavier woody matter, containing much lignin and cellulose, to be segregated from the lighter

débris, such as spores and pollens, so that the resulting coal may show local enrichments of such bodies.

Local contributions of different plant materials account for the commonly banded appearance of bituminous coals. The differentiation of such banded coals into physically distinct components—vitrain, clarain, durain and fusain—enables a study to be made of the extent to which local enrichments affect the properties of coals, for these components of banded bituminous coals differ from one another almost entirely because of the different contributions made to them by the various parts of plants. For proper understanding of the character of bituminous coal it is, in fact, essential to study each physically distinct banded component separately.

As a result of numerous researches on banded bituminous coals, it has become increasingly apparent that the great complexity of character of the initial coal-forming materials has not been transmitted to the resulting coal. During the process of coalification and, as it would appear, during the initial stages, those of decay of the vegetable matter, many of the more important components (in quantity) of the accumulated plant-material lose their identity and by extensive alteration and interaction find a common level as 'ulmin compounds.' These ulmins form a definite class of compounds, not necessarily homogeneous, but probably comprising several distinct types, yet sufficiently alike in their chemical constitution and behaviour to justify their being grouped under one head. So far, no separation of the naturally occurring ulmins into markedly different classes of compounds has been obtained experimentally.

The plant materials that contributed to the ulmin group of compounds are the structural portions, the lignin and celluloses of the cellular framework, together with much of the cell-contents, namely, carbohydrates and proteins. These materials formed the bulk of the plants, and the resulting ulmins form the bulk of coal. The predominance of ulmins is already apparent in an accumulation of plant débris after a comparatively short process of decay, *e.g.* in peats, in which alkali-soluble ulmins are found in increasing amounts as the age of the peat increases. The ulmins, as first formed, are not permanent, unchangeable compounds, but are subject to progressive alteration according to the conditions to which they are subjected. Their progressive alteration becomes most apparent in a decrease of solubility in alkalis, partial in the lignites, complete in bituminous coals. Over the whole range of coals, also, the ulmins progressively alter, more particularly as regards their ease of oxidation, as the 'rank' of the coal increases. There is good reason for the belief that the rank of a coal is mainly determined by the change that has taken place (by such factors as pressure, temperature and time) in the ulmins it contains.

The parts of plants which do not undergo decay, with the formation of ulmins, are the protective coverings of plant tissues, such as the coats or exines of spores and the cuticles of stems and leaves, together with certain special plant products such as the resins. These are not readily subject to decay, nor are they readily altered by the conditions attending coalification, so that they are found in coal but slightly modified from their original forms and in quantity greater than corresponds with their original proportions in the plant débris. There are also present in coal small quantities of free hydrocarbons, probably derived from the oils and waxes of the plants during the processes of decay and coalification. These three classes of plant materials, protective tissues, resins and hydrocarbons, though different in character, can conveniently be grouped together as 'resistant plant remains.'

A normal coal can be regarded as essentially a mixture of the two groups of compounds, 'ulmins' and 'resistant plant remains.' It can be confidently anticipated that, as the result of work now in progress, the nature of any coal can be related to (a) the character of its ulmin compounds, and (b) the contents and nature of its resistant plant remains, so that a rational classification can be obtained. There seems to be no possibility of compounding the influence of these two groups of materials, for their effects on the character of the coal composed of them are independent.

At present our knowledge of the extent to which each of these main component groups of compounds affect the behaviour of coal under different conditions is incomplete, but it is possible to relate one or other property broadly to the presence of one or other component. For example, in those reactions of coal which involve its oxidation the ulmin compounds play the major part; while the behaviour of coal on destructive distillation, as regards its yield of tar, is determined mainly by its contents of resistant plant remains. The 'coking-power' of a coal (its ability to yield a commercial coke) depends on too many factors to permit of its being related

so simply to the presence of some 'coking ingredient,' nevertheless, it should be possible to deduce the coking properties of a coal from its chemical constitution. The resins, and to a certain extent the hydrocarbons, appear to play the part of agglutinating materials, but it is clear that the character of the infusible part of the coal is of equal importance.

Followed by Discussion.

Mr. J. I. HODGSON.—*An Examination of the Problem of Utilising the Earth's Internal Heat.*

The paper attempts to collect the essential data and to formulate the principal difficulties which bear upon the problem of utilising the earth's internal heat, and to present these in a form convenient to engineers.

The earth's total reserve of heat, the heat lost by radiation into space, and the amount of heat produced by radio-active materials in rocks are estimated.

The distribution of radio-active materials and their effect on the temperature gradient of rocks is discussed.

Reasons for assuming that the interior of the earth is getting hotter rather than cooler, and is solid rather than liquid, are given.

The rates of heat leakage from a cylindrical bore-hole in the centre of a hot slab of heat-insulated material which (a) does not contain radio-active material, and (b) which does contain radio-active material are calculated, and the 'heat leakage, time' curves are plotted.

The heat yield under steady flow conditions for a deep heat bore-hole is also estimated.

Means for making such deep bore-holes are considered, and details such as the use of cooling suits for the workers and the choice of the most suitable circulating liquid for the bore-holes are briefly discussed.

The probable heat yield from a deep heat bore-hole is compared with the yield of a modern boiler, and the apparently insuperable difficulties introduced by the combination of distance and the low heat conductivities of rocks are emphasised.

The paper closes with an account of what has already been done in utilising the heat available in hot surface rocks, which are usually porous or fractured, and in which heat bore-holes can be put down at frequent intervals without undue expense.

A summary of the data, the formal mathematical proofs, and certain of the technical details are given in the appendices at the end of the paper.

AFTERNOON.

Visits to Textile Works:—

Messrs. Hudson, Sykes & Bousfield, Morley.—Cloth manufacture from spinning to finished piece: modern power plant.

Messrs. Joshua Wilson & Co.—Woollen and worsted goods.

Messrs. William Lupton & Co.—All processes of woollen manufacture (initial stages at Cliff Mills, Pudsey; finishing processes at Leeds).

Messrs. W. E. Yates, Bramley.—All processes of woollen manufacture.

Saturday, September 3.

EXCURSION.

Smeaton's House. Selby. Goole Waterworks overhead tank (capacity, 750,000 gallons, height 155 ft.).

Goole Docks—Inspection and lunch (Lowther Arms Hotel) by invitation of Aire & Calder Navigation Co. Compartment train for coal. The compartments are loaded at the mines, conveyed on bogies to the canal and towed down in trains. At the docks are hydraulic hoists which tip the compartments complete into the steamers. New dock construction; the debouchment of the New River Don.

Ferrybridge Power Station.—The Ferrybridge Super-Power Station of the Yorkshire Electric Power Co. is one of the newest in the country. There are at present installed two 19,000 K.W. generating sets, but the ultimate capacity is 180,000 K.W. In the circulating pump house is the experimental axial flow pump which forms the subject of a paper in Pontefract.

Sharlston Colliery.—The New Sharlston Colliery Co., Ltd., have one of the most modern collieries in the district. Their hydraulic decking plant, new system of spiral separators for cleaning coal, &c., are unique in this country. Their system of economic power production is of exceptional interest. In their office is one of the first pair of Parsons' turbines made. Visit to the coal-face. Tea by invitation of the Company.

Wakefield.

Rothwell Haigh Collieries.—Messrs. J. & C. Charlesworth. Three very old pumping engines, the oldest of which was probably originally of the 'Newcomen' type, erected in 1776, converted to 'Watt' type in 1793. The engine at one time pumped water to work a 'water balance' for winding coal in adjacent shafts. There is a 'horse gin' for raising and lowering men working in the shaft.

Monday, September 5.

Mr. P. DUNSHEATH, O.B.E.—*Super Tension Cables.*

The transmission of large blocks of power by underground cable is a subject of great interest at the present time, and the paper reviews some of the most important features of the problem. The working of cables at higher voltage is necessitated by both technical and economic considerations, and the latter are illustrated by a series of curves in which estimated costs of plant for typical super tension transmission are plotted to show the interdependence of different factors, such as voltage and distance. Time effects in cable failure are briefly discussed, and the characteristics and significance of dielectric loss and power factor explained. In comparing the relative merits of plain three-core and metal-sheathed core cables, it is shown that the latter have decided advantages, and one form, the reinforced S.L., possesses outstanding features. When voltages of 66,000 and above are contemplated, the single core cable becomes a serious rival to the three-core construction, and then eddy current losses in the sheaths have to be guarded against by keeping the three cables as close together as possible and avoiding individual magnetic armouring. The progress already made in cables for 132,000 v. systems is referred to, and the paper closes with a discussion on the difficult, but important, problem, the assessment of cable quality.

Mr. H. W. CLOTHIER.—*Switchgear for Alternating Current.*

After a reference to the comparatively recent rise of the science and industry of switchgear, the paper proceeds to indicate the distinction between Continental, American and British designs, and to state the general tendencies of present-day developments in America and in Great Britain. Future designs will be controlled by the results of research on outstanding problems; and the paper therefore states some of these problems and their lines of solution as an avenue to a forecast of the future. The problems dealt with are those of: (1) Insulation, under the headings (a) general, (b) need for care in manufacture, (c) material for abnormal conditions, and (d) cable insulation; (2) Relief to operators, with special reference to means of ensuring safety and accuracy of operation; (3) The breaking capacity of circuit-breakers; (4) Metal-clad auxiliary apparatus; (5) Measurement of currents in high-voltage circuits; (6) Economy, as influenced by various factors; and (7) The draw-out feature in metal-clad switchgear. The essentials for safety in all electrical plant and devices are: (1) Complete enclosure of all conductors when alive; (2) Effective earthing of all accessible metal which may otherwise become alive by accident; and (3) Easy and safe means of isolation of moving parts for inspection and maintenance; and illustrations are given to show how these fundamental principles are applied to switchgear, ranging in size from a domestic plug up to the very largest circuit breakers for super-power stations. The paper concludes with a reference to possible lines of future development, stressing especially the primary need for absolute freedom from failure in switchgear if it is to fulfil its function of protecting the supply against breakdown or interruption.

Mr. F. MURGATROYD.—*The Mechanical Strength of Metal-Filament Electric Lamps.*

The mechanical strength of metal-filament lamps is a matter of primary importance to many users, some of whom may purchase each year thousands of lamps

which are used under conditions of mechanical shock and vibration. The paper seeks to examine the subject comprehensively; to state the facts now established by research and experiment; and, finally, to define the path of future progress.

Under 'General Considerations,' the subjects of light efficiency, and the use of gas, spirals filaments, and anti-vibration fittings are briefly considered.

A second section on 'The Metal Filament' deals with the subjects of grain growth and grain size, effect of stress on deformation and fracture, effect of vibration, the transition temperatures of tungsten, and the effect of temperature and intensity of vibration. From metallurgical arguments, it is concluded that a filament is always weaker when hot than when cold. Large crystals are desirable in order that crystal growth may be minimised and ductility increased, although it is pointed out that the use of large crystals does not necessarily mean increased strength, owing to fracture being generally intra-crystalline.

In a third section, particulars of practical shock tests of lamps are given, together with a view of the automatic shock-testing machine used. As a result of a large amount of shock testing work on various types of lamps, it was conclusively demonstrated that a lamp is weaker when burning than when cold, the weakness being due to failure of the filament which may fracture, short-circuit, or sag. The chief factor governing mechanical strength is the nature of the filament; and other factors, such as the geometrical arrangement of the filament, the type of mounting, and the general design of the lamp, are secondary. It was found that spirals filaments are not necessarily stronger than straight, and that in a gas-filled lamp any added strength due to the damping effect of the gas is negligible.

The fourth, and final, section states briefly the conclusions and recommendations. It is argued that although high temperature tends to weaken a filament, it is a retrograde step to obtain added strength by lowering the temperature, and therefore the light efficiency. Greater strength must be attained by better filament structure and not by resorting to uneconomic operation. A general adoption of the spiral form of filament is deprecated until the success of the low-consumption gas-filled lamp is established. Until then, the straight filament vacuum type lamp is advocated for low-consumption lamps, and a squat squirrel-cage form of mounting is advisable.

Since the mechanical strength of a lamp largely depends on the nature of the metal filament, the user is essentially concerned with all investigational work having for its object the improvement of the filament. Hitherto he has known little about the filament for which he is paying. It is suggested that advantages might accrue to both the large user and the manufacturer by indicating on the lamp bulb the type of filament used. A method of symbols could be adopted similar to that which works successfully in the carbon-brush industry. Although such a system would not tell the user much about the filament, it would give him an assurance that he is buying a known article, the qualities of which have been determined, or a new article, the qualities of which he may then compare with those already known. The user who wishes to co-operate would, at any rate, be in a position to add his practical experience towards the attainment of the desired ideal.

Dr. J. HARTMANN.—*The Jet Wave Rectifier.*

Mr. F. C. TURNER.—*A Thermionic Valve Type Close Voltage Regulator.*

The paper describes a method of automatically controlling the voltages of D.C. generators within fine limits.

The load on a generator consisting of constant temperature furnaces and fatigue testing machines running for long periods is described, and the effect of changes in the generator voltage considered. It is shown that for his special case the allowable variation is of the order of plus or minus 0.5 volt in 200.

Alternative methods of maintaining constant voltage are discussed, and are shown to generally permit too large a variation and to be comparatively expensive. The evolution of a thermionic valve operated relay is described which gives control of the desired order at a moderate cost. A double element regulator capable of controlling within plus or minus 0.03 volt is explained. A description is given of the design and operation of a heavier time lagged relay and rheostat control, worked by the fine relay.

The behaviour of the complete regulator over a considerable period is dealt with, and possible modifications of control mentioned. The paper is illustrated.

AFTERNOON.

Visits to Works:—

The Leeds Forge Co., Armley and Newlay.—Railway rolling-stock construction.
Well House Foundry, Messrs. Joshua Buckton, Ltd.—Testing machines, heavy machine tools, enveloping worm-gear.

Tuesday, September 6.

Prof. W. T. DAVID.—*The Efficiency of Internal Combustion Engines.*

The suggestions made in this paper are (i) that calculations of the *ideal* efficiencies of internal-combustion engines should be higher than those usually made, and (ii) that they increase with compression ratio at a greater rate than is generally supposed.

(i) Experimental work has been carried out during the last few years at Leeds in conjunction with Messrs. S. G. Richardson, W. Davies, R. A. Smith and B. H. Thorp, upon explosions of inflammable gaseous mixtures contained in closed vessels by means of flame photography and optical indicators. The experiments suggest that the usually accepted values for the specific heats at high temperatures of gases constituting the products of combustion are too high. The reason for this is that specific heat values have been calculated from explosion experiments on the assumption that the whole of the gaseous mixture has been burnt and is in thermal equilibrium by the time that the maximum pressure is reached. The flame photographs, together with pressure measurements in explosions covering a wide range of mixtures in which the proportion of H_2 or CO and O_2 and N_2 were varied, show that this assumption is not justifiable even in the case of those mixtures in which a large excess of the reacting gas is present. The significance of this in connection with internal combustion engines is that the ideal efficiencies calculated on the basis of specific heat values deduced from explosion experiments are too low.

Engine experiments by Mr. H. Ricardo support this view. He finds that the measured thermal efficiency of an engine approaches too closely to the ideal value calculated upon the basis of the generally accepted specific heat values to give one confidence in the latter.

(ii) Closed vessel explosions also show that for a mixture of any given composition, the ratio of the maximum pressure reached on explosion to the initial pressure of the mixture before explosion increases as the initial pressure is increased. I have suggested that the causes responsible for this are (i) more complete combustion with increasing density, and (ii) that the specific heats of CO_2 and water vapour at high temperatures decrease with increasing density.

Engine experiments by Messrs. Tizard and Pye are of interest in this connection. They show that the thermal efficiency of an engine working on a mixture of any given composition increases as the compression ratio increases to a greater extent than that to be expected from their efficiency calculations which are based upon specific heat values assumed to be independent of density. If, as I have suggested, combustion becomes more complete in the early stages of the expansion stroke, and the specific heats of the products of combustion at high temperatures decrease as the density increases, the explanation is clear.

Mr. H. R. LUPTON and Mr. J. H. W. GILL.—*Low-lift Axial Flow and Centrifugal Pumps.*

Mr. R. BORLASE MATTHEWS.—*Transport on the Farm by the Aid of Electricity.*

It is contended that agriculture—the largest industry in every country—must be industrialised if it is to be profitable. To attain this end transport must be done electro-mechanically. In the field wagon loaders should be employed, and at the barn the loads should be removed and transported in single lifts. Any redistribution of the crops should be made by aid of automatic grapple forks. Chain conveyors should supply the threshing machine, and mechanical or pneumatic conveyors should carry away its products to granary, chaff room and straw barn. Thus the complete threshing operation can be carried out with three or four men as compared with the usual round dozen. With every electro-mechanical aid in the cow byres the work

of cleaning, feeding and milking of 150 cows can be accomplished by three men, as against the fifteen normally needed. A central hydro-manure plant to distribute the manure over the farm hydraulically saves a lot of labour, both of men and horses. Over eight tons of produce have to be transported on a farm per arable acre, plus $3\frac{1}{2}$ tons of milk per cow, and at least another nine tons of manure per acre has also to be carried and spread. This means a total of 8,152 tons to be transported annually on a farm with 420 acres of arable land—no mean proposition. Hence the importance of modern electro-mechanical means of transport.

MR. H. W. SWIFT.—*The Transmission of Power by Belts.*

The fundamental principles of the operation of a driving belt are still incompletely understood; in particular, opinion on the mechanism of creep and slip is still divided, and relations obtained by causing a belt to move slowly over a stationary pulley are still applied to running conditions.

Discussion of the transfer of power by an extensible belt shows that so long as the tension ratio (T_1/T_2) is less than that ($e^{\mu\beta}$) corresponding to the limiting co-efficient of friction and angle of embrace, relative motion on either pulley will only occur over the 'active' arc of embrace which extends back from the point of leaving through an angle β where $T_1/T_2 = e^{\mu\beta}$. The successful operation of crowned pulleys and twisted drives depends on this fact. Preliminary experiments demonstrated that 'static' tests do not enable the running characteristics of a belt to be predicted.

A new plant for the testing of belts under running conditions is described, by means of which the speed, power and mean tensions can be controlled and measured and the loss of speed and power determined. Power is obtained from a variable speed motor, and may be returned mechanically by means of a return belt which permits greater powers to be transmitted by the belt under test than can be obtained from the driving motor.

A series of tests carried out under constant mean tensions at a low belt speed (1000 f.o.m.) show that the creep-power characteristic can generally be predicted with some confidence from the known elastic properties of the belting, and that serious bodily slip occurs at a value of the tension ratio which corresponds tolerably well with that obtained from a 'static' test. The characteristics for various classes of leather and fabric belting are compared, and the ratio $\frac{T_1 - T_2}{T_1}$, defined as the 'Co-efficient of Performance,' is proposed as a useful criterion of the effectiveness of a driving belt.

The practical conditions of operation at constant centre distance are discussed; changes in mean tension with power transmitted are examined for horizontal drives and the results of experiments are given to confirm the results obtained.

AFTERNOON.

Visits to works in Hunslet district:—

- (i) AIREDALE FOUNDRY.—Messrs. Kitson & Co., Ltd.
 - (a) A Kitson-Still Locomotive—a combination of an internal combustion and steam engine; as applied to a locomotive this is a new departure.
 - (b) Three engines for Western Australia.
 - (c) Special foundry work in connection with complicated cylinders for locomotives.
 - (d) Surface combustion appliances applied to furnace work, heating, cremation, and cooking.
- (ii) STEAM PLOUGH WORKS.—Messrs. J. Fowler & Co.
 - (a) Cultivating machinery (cable-drawn implements, forest clearing engines, steam and motor tractors).
 - (b) Road transport machinery (steam wagons, traction engines, &c.).
 - (c) Road-making machinery (rollers, sprayers, gritters, scarifiers, &c.).
 - (d) Construction machinery (concrete mixers, &c.).
 - (e) Light railway machinery.
- (iii) HUNSLET ENGINE WORKS.
 - (a) A series of engines for Ceylon.
 - (b) Shunting engines of latest L.M. & S. Rly. type.
- (iv) MIDLAND ENGINE WORKS.—Messrs. J. & H. McLaren.

- (a) Agricultural machinery of many kinds.
 (b) Examples of the new McLaren-Benz high-speed heavy oil engine.
- (v) SUN FOUNDRY.—Messrs. Hathorn Davey.
 (a) Water pumping plant for Ahmedabad.
 (b) Sewage pumping plant for Karachi.
 (c) Large irrigation screw pumps for fen drainage.
- (vi) LEEDS MEADOW LANE GASWORKS.
 Inspection of the old Middleton viaduct, by invitation of the Superintendent.
 The first steam locomotive ran on this viaduct in 1812.

Wednesday, September 7.

Mr. J. GILCHRIST.—*Strength of Reinforced Concrete Beams in Shear.*

1. Results of compressive and tensile tests of concretes used in the beams tested : between 1000 and 5000 lbs. per square inch the compressive strength can be expressed in terms of the tensile strength by the following formula :—

$$C=12(T-1000)$$

where C is the compressive strength of the concrete and T its tensile strength, both in lbs. per square inch. Above a compressive strength of 5000 lbs. per square inch there is not the same increase in the tensile strength for this particular kind of concrete, which was made of varying mixtures of cement fondu and crushed millstone grit to pass through a quarter-inch riddle.

2. Shearing strength of beams of T section, with straight tension reinforcement bars hooked at the ends, with no verticals or shear reinforcement whatever. The following table gives the practical minimum values of the shearing stress at the neutral axis near the end of the beam calculated on the ordinary beam theory from the results of the tests.

C.	T.	C.S.D.C.		C.S.B.L.	
		1% steel.	1½% steel.	1% steel.	1½% steel.
1000	183	160	210	290	350
5000	520	290	420	350	500

C and T are the compressive and tensile strengths of the concrete, C.S.D.C. is the calculated shear stress under the load at which the first crack was seen in the region of greatest shear ; while C.S.B.L. is the calculated shearing stress at the breaking load. All the figures are in lbs. per square inch.

The author had previously stated in a paper published in *Engineering* in 1915 that, for a concrete of about 3000 lbs. per square inch compressive strength, the failing shear stress of a beam would be 275 lbs. per square inch, this being a conclusion from published tests. In the above table the corresponding figure would be the mean of 290 and 350, that is 320 lbs. per square inch.

Mr. H. H. BURNES.—*Large Low Head Conduits.*

Mr. T. M. NAYLOR.—*The Whirling of Shafts.*

Some years ago a discussion took place as to whether there was a disturbance before the whirling speed proper. A further discussion followed as to whether the disturbance occurred at $\frac{1}{2}$ or $\frac{1}{\sqrt{2}}$ of the whirling speed proper.

Before describing his experiments, the author gives a brief summary of the matter published on this point. Then he describes his experiments and gives photographs of the disturbances which occurred when experimenting with an overhung shaft loaded at the end.

The conclusion arrived at is that there is a disturbance at $\frac{1}{2}$ the whirling speed proper.

Report of the Earth Pressure Committee.

SECTION H.—ANTHROPOLOGY.

(For references to the publication elsewhere of communications entered in the following list of transactions, see p. 433.)

Thursday, September 1.

Mr. R. G. COLLINGWOOD.—*Roman Signal Stations on the Yorkshire Coast.*

A considerable number of small Roman forts exist on the Yorkshire coast, all situated on high commanding ground such as Scarborough Castle Hill, Filey Brigg, &c., and each consisting of a stone rampart and ditch enclosing a strong central foundation evidently intended to support a tower. These fortified towers, several of which have been dug in the last 15 or 20 years, are signal-stations of a type evolved by a continuous process from a light wooden signalling-turret used in the early Imperial age; as time went on, the system of signalling developed and the signal-stations became more massive and partook more of the character of miniature forts. These Yorkshire specimens are of unusual interest as evidence of the measures taken in the late fourth century A.D. to secure Britain against the piratical raids of Saxons and other tribes. They belong to the latest phase in the Roman occupation of Britain, and there seem to be references to them in the literature of the period. Five stations have been discovered, reaching from Scarborough to Saltburn; it is highly probable that there were many others, some awaiting discovery, some doubtless destroyed by coastal erosion. In at least one case—Scarborough—the Roman site is curiously complicated by prehistoric remains below it and mediæval above.

Mr. S. N. MILLER.—*Roman York: The excavations of 1925–26.*

Most of the excavation has been done within the east corner of the fortress near Monk Bar. There has been a little supplementary digging in the Museum Gardens, by permission of the Yorkshire Philosophical Society. The total area so far excavated is small, and the conclusions it indicates are therefore to be regarded as provisional.

Remains have been discovered of the clay rampart and wooden barracks of the original legionary fortress, which seems to have been established c. 71–74, in the governorship of Petilius Cerialis. The clay rampart was later replaced by a stone wall with an earth backing, probably c. 104–108, in Trajan's reign, and the first stone tower at the east corner would seem to date to that period. There is evidence to suggest that the tower and wall had to be repaired early in Hadrian's reign as the result of a destruction which may have had some connection with the disappearance of the Ninth Legion and its replacement by the Sixth. This, however, requires confirmation, and here valuable evidence may be given by the series of interval towers, the sites of which can now be laid down round the circuit of the defences as the result of the fortunate discovery of a well-preserved example between the east corner of the fortress and Monk Bar. Whether or not the fortress suffered a disaster towards the end of Trajan's reign, it now seems certain that extensive damage was done in the serious trouble which broke out early in the reign of Commodus and led to the abandonment of Scotland (c. 182). During the lengthy period of restoration that followed the damage done at York was repaired, and the wall and east corner tower as then reconstructed can now be seen near Monk Bar still standing to a height of 15 feet.

The supplementary excavations in the Museum Gardens, besides helping to clear up the interior plan of the Multangular Tower, have proved that that bastion and the adjacent length of wall form one homogeneous structure, dating to the opening years of the fourth century, when Constantius was in Britain. How far this late reconstruction extended backwards from the river front is still to determine. So far there is no proof of any fourth-century occupation within the east corner, and it is just possible that the fortress may have been reduced in size. It is hoped that further excavation will enable the fourth-century defences to be traced, and throw light upon York and kindred fortresses as they existed under the military system represented by the *Notitia Dignitatum*.

Mr. I. A. RICHMOND.—*The Roman Camps at Cawthorn.*

These excavations, reported to the Association at Southampton in 1925, have since been continued for two months, in 1926. The results were the complete recovery of

the plans of the wooden gates of Camp A, and the discovery of traces of a wooden front to the rampart of a type not discovered in Roman Britain before, but represented in various forms in the Rhine-lands. Unfinished earth-ovens of this period were also found, in almost every stage of construction, indicating the short life of such structures and the ease with which they could be excavated in firm subsoil. To the second period of occupation of this camp belong newly discovered rectangular pits covered with wigwam-like roofs, of which the strut-holes were found; these were apparently used for habitation, since they had hearths at their edges. A long narrow and deep pit which occurred near them was of quite different type and seems to have been a latrine-trench, but more examples are wanted. Excavations in Fort D, confined to its northern defences, produced evidence that these defences were never completely dug or finished, thus confirming surface indications on other parts of the circuit.

Much still remains to be done at this interesting site, which continues to fulfil its early promise by producing unique features in an excellent state of preservation.

Mr. L. S. B. LEAKEY and Mr. B. H. NEWSAM.—*Preliminary Report on Excavations in Kenya Colony—The Stone Age in Kenya.*

Mr. Leakey's first year's work was concerned with sites in two areas, one at Lake Nakuru in the Rift Valley, one at Upper Elmenteita. On the Lake Nakuru site evidence was found for two high lake levels, and for falls in connection with these two high levels to a point below the 200-foot level. These are the high levels which are thought to represent pluvial periods to be correlated with the glacial epochs in Europe. This suggestion awaits further examination in the light of evidence furnished by fossil bones and skulls collected from various horizons on the lake deposits. The archaeological site at Nakuru is situated 365 feet above present sea-level, and consists of a deposit along the edge of a cliff. The two upper strata show no sign of submergence, and must be later than the high-water level. In these, through a depth of 13 feet, were found ten burials with hundreds of tools, pottery fragments, &c., as well as stone bowls, these last more numerous in the upper layers. One skeleton was in almost perfect condition. It alone afforded possibility of any detailed measurement. The striking features were the length and width of the face, the depth of the mandible at the symphysis, the height of the vault of the palate and the prominent relatively narrow nose, with a low index of 50.9. The head was very long, in fact ultra-dolichocephalic. The associated industry is essentially microlithic. Beneath this stratum was a small deposit of pebbles and sand which appears to have been subject to water action. In it were a few obsidian tools and fossil bones. It is obviously older than the upper two, and has been submerged by high lake level. The tools for the most part were backed blades.

The second site at Upper Elmenteita is 393 feet above present lake level. It is situated along the edge of a cliff which consists of lava overlying an alluvial deposit, forming one side of a valley cut by a prehistoric river during an interpluvial period, and subsequently filled up by a rise of the lake, most of this later alluvium being washed away in a subsequent fall. In the residue were found remains of twenty-six individuals, scattered about at various depths, in pockets in crevices; obsidian tools and pottery and eggshell were found around with them. It is suggested that they belong to a period previous to the rising of the lake, which deposited them where they were found. All the bones are more or less fossilised and well preserved. The human remains include at least two skull types—a primitive type, Elmenteita A., and a less primitive, but with one or two remarkable features, Elmenteita B. In skull A the remarkable feature is the mandible, which has a very deep bone at the symphysis—41 mm.; the relative height of the ascending part, and the obtuseness of the angle; also the low forehead, the length of face, the bizygomatic width, compared with the breadth of the skull, and the exceptionally long and narrow nose, index 47.4. The skull is very dolichocephalic, the relation of breadth to length being 68.2. Skull B differed from skull A in its greater breadth, index 75; the capacity of the skull exceedingly high, 1680.96; the nose, exceptionally narrow, index 40, and the jaw, exceptionally long. Neither of these types resembles the modern negroes of the country.

The third site, at Upper Elmenteita, is a cave or rock-shelter, on the side of a steep valley 216 feet above stream level, and 594 feet above lake level, and has yielded important stratagraphical evidence: 1, 2 and 3 are modern layers, contain no tools; 4 is a barren layer of alluvial silt; 5, a layer of rock rubble from roof; 6, 3 feet of

hearth earth, containing pottery, tools, &c., and animal bones; 7, rock rubble from roof; 8, layer as 4; 9, layer of rock rubble; 10, layer of hearths with implements and bones; 11, burials. If, as it is argued on the geological evidence, the two alluvial deposits here are deposits of the two high lake levels, the first prehistoric period belongs to the last interpluvial and the second to an earlier one. Of the prehistoric horizons, the first or later belongs to the Neolithic in culture if not in time, resembling the industry of the first Elmenteita site (Mr. Monroe's farm), while the second is much cruder and contains no pottery, but rough flakes with just a very small trace of secondary chippings. Large quantities of small rodent-like animals had been found, but none of the human remains has yet been taken from the burials.

Lastly, a drift across the Enteril River gives a section across the alluvial plain 330 feet above present lake level in the deposits of the last pluvial period, in which appear a number of obsidian tools, chiefly lunates and backed points associated with fossil bones and teeth of some extinct form of hippopotamus.

REV. H. J. DUKINFIELD ASTLEY.—*Cup and Ring Markings.*

The real origin and significance of these mysterious markings are to be found in the endeavour of primitive man to express by signs, the meaning of which was understood by him and his fellows, the ideas which he would convey to them.

It is suggested, therefore, that in these signs or markings we have at once both a primitive form of heraldry and the beginnings of an alphabet; as a primitive form of heraldry they are connected with Totemism. Various theories have been advanced as to the magical or religious significance of the markings; other theories are that they were astronomical, or intended to be maps of the locality in which they were found, and the like. A study of the examples which are to be seen, for instance, at Ilkley will be sufficient to show the baselessness of these theories.

DR. H. M. AMI.—*Recent Discoveries at Combe Capelle.*

The paper deals with the various discoveries made during the last two seasons at Combe Capelle by students of the Canadian School of Prehistory organised under the auspices of the Royal Society of Canada and under the ægis of 'Les Beaux Arts' of France.

Many interesting types of previously unrecorded industries of Monstierian Age are described, and an attempt is made to correlate the discoveries made at Combe Capelle with those of La Micogue, Le Monstier, La Ferrassie and Les Eyzies.

The four beds (or zones de terrain) in which the materials were found offer an interesting succession of objects in stone as well as of bones and teeth of animals of early Quaternary Period, which, when taken together, afford excellent criteria, by means of which the industries of man and the faunas of the period can be determined to advantage.

DR. T. ASHBY.—*Roman Roads in the Valley of the Tiber.*

I pointed out in my Presidential Address to Section H two years ago that one of the principal factors in the growth of the power of Rome was her command of the only permanent crossing of the Tiber in the lower part of its course. The bridge which was established just below the island, within the area of that part of the river bank which was protected by the city wall and by a fort on the Janiculum, was only the successor of a ferry which probably existed long before there was any city on the site of Rome at all, and was used extensively for trading purposes. Another ferry must have been situated at Fidenæ—where there was never a bridge—a few miles up the river from Rome, and its existence explains the continual struggles between Rome and Veii for the possession of that important strategic point.

Like several others higher up, it continued to exist in imperial times; and thus the roads on each bank, which are of very early origin, were kept in communication with one another; for the absence of bridges even above Rome is most striking, while below the city even ferries were entirely lacking, except at Ostia itself. The Via Flaminia, with its two bridges taking it into and out of Etruria, distant respectively 3 and 42 miles from the city, is a purely military highway, and dates only from 220 B.C.: and a theory recently advanced that the first of the two, the Pons Milvius, has taken the place of a very early crossing has little to commend it.

DR. FELIX OSWALD.—*Recent Excavation on the Roman Camp of Margidunum on the Fosse Way.*

Excavation carried on for several years has revealed the fact that the Roman camp of Margidunum, situated on the Fosse Way, halfway between Leicester and Lincoln, was founded in the reign of Claudius, probably by Ostorius Scapula, when (according to Tacitus) he built a series of frontier-forts between the Severn and the Trent (*i.e.* along the Fosse Way) to secure his hold on the country during his advance into Wales. Margidunum is rhomboidal in outline, with an area of about 7 acres, and probably held a garrison of 1,000 men. It was strongly defended by as many as six ditches and a wooden stockade, burnt apparently during the Boudiccan insurrection, when Cerialis and a remnant of cavalry of the Ninth Legion fled to Lincoln after being ambushed. The camp is traversed by three parallel roads, but the headquarters building is in a field not yet available for excavation. Dr. Oswald is at present excavating a large bath-house on the west side of the fort, interrupting the continuity of the ditches. Margidunum ceased to be of military value at the beginning of the second century, and was completely dismantled, even foundations being removed; it became a mere posting-station, mentioned twice in the Antonine Itineraries. In the fourth century, after Theodosius had repelled the invasion of the Picts who had laid waste nearly the whole country, Margidunum was refortified by a stone wall on a concrete foundation, 9 feet thick, and continued to be occupied down to the end of the Roman occupation. The pottery is abundant and remarkably varied, and is of great chronological value when occurring in numerous wells, sealed-up pits and ditches; it belongs to all periods, from pedestalled urns of late Celtic type in Claudian wells to the imitation 'Samian' with 'daisy' pattern of the fourth century.

Friday, September 2.

Presidential Address by Prof. F. G. PARSONS on *The Englishman of the Future.* (See p. 138.)

Sir W. BOYD DAWKINS, F.R.S.—*The Place of Man (Homo sapiens) in the Tertiary Period.*

The study of mankind, formerly confined to history, has now been extended through prehistory far back into the geological record, in which Man (*Homo sapiens*) is the last outcome of the mammalian evolution which characterises the successive stages of the Tertiary Period. In this evolution the Anthropids—universally taken to be intermediates between man and the higher apes—appear in the Late Pliocene or the Early Pleistocene, and apparently become extinct in Europe before the close of the Pleistocene Age.

In Europe and in Palestine they occur in association with rude stone implements of the Chellean, Acheulean and Mousterian groups of the French archæologists, a fact which raises the question as to whether the whole of the Early Palæolithic implements, generally assigned to man, should be referred to one or other of the anthropids. All the reputed cases of their association with *Homo sapiens* which I have examined turn out to be burials in later times. I should therefore answer that question in the affirmative. The anthropids passed into Europe from their centres of evolution in the warmer regions of Africa and Asia along with the animals now living in warm climates, such as the hippopotamus. They ranged as far north as Yorkshire, occupying the same hunting grounds in middle and northern Europe as their successors the artists of the caves. The artist cave-dweller—the earliest representative of *Homo sapiens* in Europe—has left his remains in strata that overlie those containing the implements of the anthropid hunters, and are therefore of later date and proved by the associative remains to belong to the last phase of the Pleistocene. He appears in Europe as an emigrant from Asia—a well-equipped hunter highly developed in brain and body and of the same physique as the Iberic or Mediterranean tribes that form the basis of the present population of Europe. He found his way into Britain when it was part of the Continent and lost his characteristic arts and crafts during the vast period of the slow depression of the Atlantic border, which created the British Isles and forms the hard-and-fast line between the Pleistocene and Holocene periods. He probably was absorbed into the invading Neolithic tribes

that also came in from Asia, bringing with them the domestic animals and the Neolithic culture at the beginning of the Holocene age.

Of the Holocene it only remains to note that prehistory shades into history, so that what is prehistoric in one region is historic in another. The records of Chaldea and Egypt, going back to about 4000 B.C., are the limits to the possibility of fixing a date in years.

While, therefore, we cannot date the arrival of man in Europe, we can be sure of his vast antiquity, and trace him back to the last phase of the period when the British Isles were the uplands of the Pleistocene Continent.

Prof. T. H. BRYCE.—*On a Collection of Human Skeletons from the North of Scotland dating from the Viking Period.*

The bones which form the subject of this note were recovered from a group of graves in Caithness, excavated by Mr. A. J. H. Edwards, of the National Museum of Antiquities, Edinburgh. The graves were of a type not before described, but in some particulars resembling those described long ago by Laing and Huxley. They were discovered during the partial removal of a turf-covered, sandy eminence. The structural detail of the graves varied, but the typical grave was surrounded by a well-formed kerb enclosing a rectangular or circular space some twelve feet across. This was occupied by a rudely built wall which served to enclose an elongated chamber of about 7 to 10 ft. long by 3 ft. 6 in. broad. The upper stratum of the wall was formed of rounded pebbles of white quartzite. The chamber or cist contained two or more skeletons fully extended—the bodies being in some cases separated by flags set upright, in other cases they were enclosed in cists placed at different levels. The orientation was commonly roughly N.W. and S.E., but varied. The head was generally placed at the north, but sometimes at the south end of the grave.

There was a remarkable absence of grave goods, the only relic found being a bronze chain round the neck of the skeleton of a young female. The poverty of the graves distinguishes them from those hitherto recognised as Viking. The kerb differentiates them from graves belonging to the Norse Early Iron Age. They most closely resemble graves in Bornholm and Gothland of various periods of the Early Iron Age. The bronze chain belongs, in the form of its links, &c., to a type found across the North Sea and dating from about 1000 A.D.

The people buried in these graves were of low stature, the average height of the men being 5 ft. 5 in., and that of the women 5 ft. $\frac{1}{2}$ in. This contrasts with the average stature of the Caithness men among Dr. Tocher's recruits, which was 5 ft. 8 in.

In considering these skeletons, another group from an underground building at Renniboster, Orkney, with exactly the same general characters, has been included.

The skull form is dolichocephalic, the average index for the males being 74, and that for the females 75.6. This last figure is unduly high, being raised by the inclusion of one broader skull, the only one in the series which approached the limits of brachycephaly. These indices are lower than any other larger and more modern series. They may be taken to represent the main factor in the population of the north of Scotland in their early days. The type differs little from that prevailing to day.

A typical Viking grave excavated by Mr. Edwards, with iron axe, umbo of a shield, an iron knife, bronze pin, &c., may be given as a contrast. The stature of the man was about 5 ft. 6 $\frac{3}{4}$ in. The skull was brachycephalic with an index of 82, and not of Nordic type.

The chief interest of the skeletons lay in the characters of the leg bones. In the majority the angle of torsion, so called, of the femur was high, sometimes very high, and associated with the forward directed head, the upper part of the shaft of the bone showed a distinct outward twist. The so-called torsion of the tibial shaft was also great in most cases. Further, the outer tibial condyle was generally convex posteriorly, and the border of the talar surface was faceted. In these respects the bones resemble those of certain peoples who habitually adopt the squatting posture, and we may conclude that the same was true of these early northern folk.

Dr. ALFRED A. MUMFORD.—*Body Measurements, Respiratory Tests and School Progress.*

Body measurements and respiratory tests have been taken during school life in order to study (A) Body Growth, (B) Progress in power and endurance, (C) the relation A and B bear to School progress. Some preliminary enquiry has also been made into their relation to subsequent University career.

The measurements usually taken during school life are those of Height and Weight. When considered in relation to each other, as well as to age, such measurements often afford useful indication of the degree of nutrition and the presence of circumstances favourable to general growth among pre-adolescent children. But when we come to consider the physical progress of the adolescent child, other measurements and tests must be added, particularly those connected with the degree of respiratory development, viz., chest girth and vital capacity. If we wish to estimate the value of special kinds of physical training in sports, we need to make additional measurements, e.g. thoracic diameters, shoulder girth in relation to trunk length, upper and lower arm girth, &c. We may also use the endurance test, or power to hold the breath against a definite pressure, or we may study the regional movements of the chest walls.

We gain little by considering body measurements or respiratory tests singly. We must consider them in their mutual relationship. This may be described in the form of 'indices.' Height-Weight indices give us some knowledge of nutrition. Thoracic indices, based on the relation of antero-posterior to lateral diameters, provide information about the shape of the chest and, when combined with shoulder trunk indices, that is the relation of shoulder girth to trunk length, provide information about the development not only of the shoulders and arms, but of the underlying development of the respiratory organs. Further, height, weight and chest girth not only give an index of body build but, combined in the form of a certain index, provide a relevant figure descriptive of the relation of volume to weight, that is the specific gravity or buoyancy of the body.

The terms physical fitness and physical efficiency are frequently used as if there were some uniform standard either of body build or physiological function by which we could measure the vigour of all classes of individuals. It is necessary to take into consideration the special characteristics of the body build and the aptitude for special activities before we assign these terms, for there are probably as many forms of physical fitness and physical efficiency as there are forms of physical activity. Swimming, harriers, sprinting, boxing, wrestling, all make special demands both on body form and method of respiratory action.

Although body measurements and respiratory tests have been principally considered in relation with physical activity, yet full enquiry shows they are also related to mental activity and to the capacity to withstand and recover from mental strain in school life. School work calls for activity of the same organs and tissues, e.g. brain, heart, lungs, and skin, as does bodily exercise, though in a different way and in a different degree. Undue activity of body or mind leads to overstimulation of one and neglect of the other. In either case the complete functions of the body organs are not called out. Early failure follows overstimulation of one aspect and under-stimulation of the other.

Numerous tables, diagrams and charts will be shown to illustrate the above-mentioned points.

Prof. H. S. FLEURE and Miss R. M. FLEMING.—*Demonstration of a new type of Anthropometric Instrument.*

Mr. E. K. TRATMAN.—*The Prehistoric Archæology of the Mendips.*

Nearly all past writers and many present ones on the prehistory of England either completely ignore the Mendip Hills of Somerset as an area of importance in relation to the subject or make but passing reference to such remains as they happen to have heard about. The Ordnance Survey maps too show but comparatively few sites, and one is left with an impression, after studying these maps, that the Mendips were but very sparsely populated during the various prehistoric periods.

Actually the reverse is the case. A survey shows that the caves in which parts of this district abound were, when they were at all suitable for habitation, occupied

in Palæolithic times as well as in many cases in the succeeding prehistoric periods; but as yet the *scientific* excavation of the caves has not proceeded very far and the evidence of occupation is often at present based on more or less haphazard excavations.

The succeeding Neolithic period is so far but poorly represented until we come to the closing phase of the age, but this lack of evidence is almost certainly due to want of excavation, and work now proceeding is beginning to yield a firm basis for further research.

In the Bronze Age the top of the Mendips was densely populated, so densely in fact that it rivals even Wiltshire, but here again much further excavation is needed in order to get a full history of the occupation during this period.

In the Iron Age the population apparently increased still further, for every possible cave yields remains either of the pure Iron Age or of Romano-British times. Man is using every available site for living purposes and is even spreading down into the valleys and low-lying marshy moors.

Thus it is seen that the Mendips were extensively occupied from Palæolithic times onwards through the succeeding ages up to the coming of the Romans, at which point our survey ends.

Mr. HERBERT TAYLOR.—*Excavation of King Arthur's Cave, near Whitchurch, in the Wye Valley.*

Intact portions of the deposits of King Arthur's Cave excavated by the University of Bristol Spelæological Society have yielded a sequence in fauna and industry from Final Aurignacian or Proto-Solutrean to a late phase of the Palæolithic.

In a passage a deposit, probably the Upper Cave Earth of the Rev. W. S. Symonds, lay directly upon the limestone floor and contained a small hearth; a fauna including *Rhinoceros tichorinus*, *Cervus* sps., *Hyæna spelæa*—all very common—*Equus* sp., *Elephas primigenius*, *Bos* sp., *Ursus* sp.; and an Aurignaco-Solutrean industry.

At the mouth, upon yellow clay formerly continuous with the cave contents, was a talus of angular fragments of limestone.

At its base the fauna was similar to the above, at its centre predominantly microtine, and at its surface cervine, including rarely the reindeer. Besides scanty industrial remains throughout the rubble contained two hearth-levels, one near the base, one at the surface beneath about a foot of humus. The industry of the lower approximates to that of the hearth in the passage; that of the upper, characterised by gravette-like pygmy implements and gravette points incompletely retouched and sometimes shouldered, is probably comparable with that of the Base and Lower Middle Zones of Mother Grundy's Parlour.

Monday, September 5.

Dr. J. P. HUTTON.—*The Significance of Head-Hunting in Assam.*

A recently published and authoritative work on Borneo suggests that the origin of head-hunting in that island may be due to a desire for human hair as ornament or for human beings to accompany the dead in the next world. These alternatives suggest that the real significance of head-hunting in the Indonesian area is as yet imperfectly understood, and the practice in Assam may throw light on the whole question.

It can be demonstrated that in the Naga Hills the souls of the dead are regarded as fertilising agents for the soil, for stock and for the human population, and practices connected with head-hunting go to show that this custom also is founded on the same underlying belief as the customs which govern the disposal of the dead.

In order to assist the fertilising powers of the dead, phallic stones are erected either as symbolic abiding places for the soul or, more probably, as actual media for the soul's exercise of its fertilising powers, and similar phallic stones are intimately connected with head-hunting, the soul being apparently transferred from the head to an erect stone as it is in some cases from the head of a deceased relative to a wooden statue of the same.

Head-hunting is a widespread practice, and it is possible that the custom elsewhere has been based on a similar theory of the soul.

Miss W. S. BLACKMAN.—*The Modern Egyptian Medicine Man.*

Mr. G. R. CARLINE.—*Primitive Weaving at Bankfield Museum.*

Primitive weaving implements and the early history of weaving is essentially a suitable subject to illustrate in a museum like Bankfield Museum at Halifax, as that town is in the centre of the weaving trade. It was on this account that the late H. Ling Roth, one of the chief authorities on primitive weaving, decided to exhibit this subject at Bankfield Museum as fully as he could. The collection starts with the usually accepted theory that weaving is probably derived from mat-making and basketry. The chief feature in weaving is the loom, and the evolution of the loom and the distribution of the various types as well as the evolution and distribution of the various accessories is the main purpose of the collection. At present the looms have been divided into those for mat-work, or in other words for unspun filament, and those in which a spun filament is used. Looms again can be divided into vertical, semi-vertical and horizontal, but probably more important than the position is the method of obtaining the 'shed.' The most primitive method is to obtain it by hand, but a great advance was made when the use of a rod was introduced to which the alternate warp threads were attached. This is the rod-heddle. The frame-heddle, which is usually worked by the feet, enabled further advances to be made in devices to accelerate the speed of working.

Mr. H. W. SETON-KARR.—*A Traveller's Impressions of the Physical Superiority of the so-called Uncivilised and Subject Races and its Causes.*

Notwithstanding the unhealthy climates in which certain native tribes and races are living, and in spite of, or perhaps because of, hard conditions of life, the author assumes from their general appearance, apart from medical statistics, that the physique of such people is superior to that of the European city-dweller. He cites some able and distinguished authorities as to cause and cure—breeding from the unfit being one of the former.

Visit to the Bankfield Museum, Halifax.

Tuesday, September 6.

Dr. H. FRANKFORT.—*The Early Prehistoric Painted Pottery of the Near and Middle East.*

The earliest painted pottery of which we know seems to be that of Susa I. At Tepe Khazineh, Tell el Obeid, and Abu Shahrein we find its descendants. But westward of the Persian mountains it appears in the earliest (pre-Sumerian ?) period. It is characteristic, however, for the *Persian-Armenian Highlands*; for in Seistan we find a descendant of the Susa I. pottery, with evidence that it persisted there while in Susa itself the second civilisation with its north-western affinities flourished. And it seems to have extended at least as far north as Rhages. Probably the early pottery from Samarra and that from Tell Zeidan belongs to it, and it may therefore be that originally Mesopotamia, as far north as the Middle Euphrates, has belonged to this culture. But on the whole the 'Fertile Crescent' is culturally opposed to its eastern neighbour. The earliest pottery of Palestine and Syria dated by its exportations into predynastic Egypt is different. This *civilisation of the plains*, which we may call perhaps *North Syrian*, is predominant in Southern Mesopotamia at the time of the earliest appearance of the Sumerians, and precedes these newcomers in Northern Mesopotamia. It is marked by polychrome pottery and theriomorphic vases, and extends from North Syria via Assur and Kish up to Susa II, thus hardly leaving the lowlands. Architectural and other characteristics contrast it with the Sumerian civilisation, and it may well be responsible for the Semitic element in Mesopotamia. Beyond Taurus there is from the beginning a third civilisation, marked first by monochrome black and then by red wares. Whether any connection existed with the civilisation of the Persian-Armenian Highlands earlier than the movements of peoples which mark the opening of the second millennium B.C., we cannot say with certainty, but it seems probable.

The painted pottery discovered in India is partly late, and then connected with Nal in Beluchistan; some of it, however, is similar to that from Tell Kaudeni in the

Zhob Valley, while other cases from Beluchistan resemble in many ways those from Samarra. Thus there is a possibility that the civilisation of the Persian-Armenian Highlands extended farther east. But in connection with *Sumerian origins* it should be remembered that the Sumerians seem in Mesopotamia to use unpainted wares throughout, and that at Mohenjo Daro also the unpainted wares are most common.

The painted pottery found in China can, with one exception, not be brought in relation with either Asiatic or South Russian wares. The exception is formed by a few sherds found at Sha Ching; these seem to resemble wares found at various points within the province of the civilisation typical for the Persian-Armenian Highlands, namely at Tepe Mohammed Djaffar, and at Urmya. The resemblance seems close both as regards technique and style of decoration, and we may perhaps assume that it spread *with the knowledge of copper-working* from a Transcaucasian centre.

Followed by discussion.

Dr. R. C. C. CLAY.—*The Overlap of the Bronze and Iron Ages.*

Recent excavation has shown that cinerary urns of the collared type were the immediate predecessors of those of the barrel-bucket-globular types. It is unquestionable that the latter were the products of invaders. The close similarity in form and decoration between the barrel-bucket-globular types of cinerary urns and the domestic vessels of the first part of the early Iron Age, also the products of invaders, suggests that the two were contemporary—one the funereal and the other the domestic ware of the same peoples. It is probable that in the south of Britain the middle Bronze Age lasted up to the introduction of the knowledge of iron.

Mrs. M. E. CUNNINGTON.—‘*Woodhenge.*’

The excavations described were carried out by Mr. and Mrs. Cunnington on a site in the parish of Durrington, Wilts. A photograph from the air taken in the summer of 1926 revealed a series of pits enclosed within a circular bank and ditch. On excavation these pits have proved to be arranged in a series of six concentric ovals, and to have once held the bases of timber posts or uprights. The pits forming each ring are fairly uniform in size, but they vary in each ring. Thus the outermost ring consists of 60 comparatively small holes; the next of 32 uniformly larger ones; the next of 16 still larger holes; while the holes of the three inner rings are more uniform in character and of a medium size. This difference in the size of the holes clearly indicates that the uprights differed in size and character in each ring. The evidence obtained that the uprights were of timber is believed to be quite definite. The site represents a type of prehistoric monument that appears, so far as is known at present, to be unique. The plan has certain analogies to that of Stonehenge, and it can only be conjectured that this remarkable timber structure was designed for ceremonial purposes of some kind. From bank to bank the outer enclosure is 250 ft. in diameter. The site is a little less than two miles N.E. of Stonehenge.

AFTERNOON.

Prof. T. H. BRYCE.—*The Prehistory of Scotland and the Theory of the Archaic Culture.*

The object of this paper is to examine briefly some points in the prehistory of Scotland in relation to the propositions of the supporters of the theory of the archaic culture. The points are the distribution of chambered cairns in relation to mineral deposits, and to the known rites of ancient mining for gold, silver, and copper; the distribution of interments containing beakers and brachycephalic skulls in relation to that of the chambered cairns; the distribution of stone circles in Scotland and their archæological horizon; the occurrence of terraces in south Scotland and the problems they present; dry-stone building in Scotland.

Dr. A. C. HADDON, F.R.S.—*Geometrical Figures from Malekula and Ambrym, New Hebrides.*

These remarkable figures were discovered by Mr. A. B. Deacon last year. Mr. Deacon was a brilliant young student of the University of Cambridge who, after

taking his degree, went to Malekula for ethnographical investigations. He did a large amount of first-class work during the year or more that he was in the field, and died of blackwater fever as he was waiting for the steamer to take him to Sydney, where he had been appointed to the lectureship in Anthropology in the university. His death is a very grievous loss to the science of Anthropology. From time to time he sent me copies of some of his notes, and from these I have compiled the information that I now present to the section.

There is a very large number of different diagrams or figures, and the method of drawing them is handed down from generation to generation. They are made only by men, but they are not secret, as women may see them. A rectangular area is made level and smooth on the sand or ashes are spread over the surface of the smoothed earth. In drawing them a framework of simple lines, squares or rectangles is first constructed, and then, starting from a certain point, curves, circles or ellipses are described about the framework in a continuous line without lifting the finger from the sand until the original starting-point is reached. So far as possible no line is traced over a second time. The natives have technical terms for certain loops. Some of the figures represent various tubers, shells or turtle, a rat eating a breadfruit, the sun, moon and various objects and persons connected with their mythology or secret ceremonial. Many of the figures have stories about them. A number of the figures have extraordinary functions: one is used in swearing an oath. Another, called 'the path,' is drawn by a spirit in front of a rock, the path lies across the middle of the figure. As each ghost of a dead man comes along the road to the other world the guardian spirit rubs out half the figure on arriving at the rock, the ghost loses his way and wanders about searching for a road to get past the spirit of the rock. If he knows how to complete the rubbed-out half of the figure he does so, and passes along the track or path in the middle. If, however, he does not know the figure, the spirit eats him and so he never reaches the abode of the dead. Several of the figures are definitely connected with a mythical being variously termed *Ambat*, *Kabat*, *Hambut*. Sometimes he is spoken of as the being who made man; others speak of five *Ambat* who are affirmed to have been white men with narrow noses, but their descendants became black. The *Ambat* are associated with very secret fertility ceremonies, the charnel place of the clan, stone tables and upright stones, sacred pottery and other things, including a ritual use of branches of the piper methysticum, the kava tree. Until Mr. Deacon's full notes are available little more can be said about these elaborate drawings, but it is evident that they belong to that rich and distinctive cult which has spread over so wide an area in Western Oceania.

Wednesday, September 7.

Dr. R. A. FISHER.—*Measurements and Degrees of Resemblance in Triplet Children from the King's Bounty Records.*

Unlike most foreign countries, there is in Great Britain no official registration of multiple births; the existence of a Royal Bounty to parents of surviving triplet children does, however, afford a means, of which advantage has hitherto not been taken, of studying triplet cases. Since the conditions of the bounty are very wide, the records of the King's Bounty afford effectively a special registry of triplets born alive. The paper deals with an extract covering three years of these records, with the information supplied by the parents and with measurements of the surviving triplets at 6½ years of age.

Two controversial problems in connection with twins concern (i) the supposed influence of the father, and (ii) the frequency of occurrence of identical twins due to the fission of an original single zygote. Records of births of near relatives of the fathers and mothers of triplets afford decisive evidence of the influence of the father in the case of triplets. The measurements of the children afford measures of the degree of resemblance of triplets of like and unlike sex. Additional points of interest concern the precision of measurements required in such an enquiry and the precision actually attainable; the partial or complete recovery in physical dimensions of children born much undeveloped and with a low chance of survival; and the need of more comprehensive national data upon normal children as a basis for comparison.

MR. ARTHUR DAVIES.—*A Continuation of Prof. Arthur Thomson's and Mr. Dudley Buxton's 'Studies of Nasal Indices in Connection with Climate' for Africa.*

(a) Instead of the Reconstruction formula of Mr. Buxton, which is not capable of general application, it is suggested that the coefficients of temperature and of relative humidity variation can be resolved and graphed and so substituted in the formula $N.I. = \text{Temperature} \times C_T + \text{Relative Humidity} \times C_H + 38$ where C_T is value of temperature coefficient at temperature T and C_H the humidity coefficient at humidity H . This has proved applicable not only to Africa, but over the examples included in *J.R.A.I.* 1923.

(b) *Climatic Standards.*—Instead of taking average conditions of temperature and of relative humidity everywhere it is suggested that we use maximum conditions in hot moist regions (torrid zone); average conditions in temperate regions; average conditions for cold regions, because it is found the cold conditions do not affect N.I. to the extent that hot conditions do. For this reason in extreme climates a standard between average and maximum seems desirable.

(c) *Mathematical evidence and physiological aspect.*—Mathematical evidence: (1) increase of coefficients of temperature and of humidity steadily with rise of temperature and humidity; (2) higher correlation between N.I. and climate in hotter regions; (3) maximum climatic standard in hot regions and average elsewhere; minimum conditions not acceptable, i.e. heat more important than cold.

Nasal organ includes two relevant functions: (1) admission of air to lungs in sufficient quantity; (2) adjustment to temperature and humidity suitable to lung tissue. A wide nose does not interfere with function (1), but as N.I. approaches 60 the volume of air admissible rapidly decreases and interferes with function (1). A nose can widen freely, the more so because devices for cooling are less numerous and effective than devices for conserving heat. Under cooler conditions narrowing proceeds to a stage beyond which it is dangerous for function (1); henceforth the onus of adjustment to cold conditions is thrown on other organs and on artificial devices, e.g. wearing furs over mouth to form an outer warming chamber. This physiological aspect emphasises the effect of heat on N.I. and minimises the effect of colder conditions. Narrow nose and medium nose adjust to climatic changes far more readily than the broad nose. Section C suggests the physiological explanation that the broad nose is a more definite specialisation than the others.

(d) *Conclusions (tentative).*—Broad nose, i.e. high N.I., has considerable racial persistence even when environment militates against it. The broad nose, a specialisation little affected by climate, retains its significance as a test of distinction between races but not as a test of relationship of two groups unless the climates of these two groups differ.

MR. E. G. BOWEN.—*An Interpretative Map of Dr. Bryn's Anthropological Observations in Mid-Norway.*

The main object of this paper is to summarise the results obtained by re-examining the anthropological record given by Dr. Halfdan Bryn in his 'Trøndelagens Antropologi,' published in 1920. An attempt has been made to translate Dr. Bryn's records, individual by individual, into the scheme adopted by Prof. H. J. Fleure, and to make a large-scale map of the new data. An examination of the map illustrates many new points of interest, such as the mixture of other elements without marked Nordic characteristics in a region believed to be a great Nordic stronghold. Then there is evidence of a substratum in the population of the survivals of Upper Palæolithic Man and further evidence that red-haired people have a peculiar distribution. Survivals of Upper Palæolithic Man are noticed for Sweden by Ekholm and other contributors to the recent book on 'The Racial Characters of the Swedish Nation.'

MR. J. E. DANIEL.—*Distribution of Religious Denominations in Wales in its relation to Racial and Social Factors.*

(1) The Anglican Church with its emphasis on outward decorum failed to take the place of Roman Catholicism in the districts inhabited chiefly by dark long-heads.

Anglicanism took root in English centres, e.g. county towns, market towns, castle towns, among a Nordic type.

(2) Puritanism owed much to Continental weaver refugees settling in wool-producing areas, e.g. Radnorshire, Quakers and Baptists; and parts of Montgomeryshire, Independents (Llanbrynmair, &c.). Baptist and Independent movements also in towns along the coastal plain of S. Wales. Independence or Congregationalism especially in Towy Valley among Alpine folk—note present co-operative schemes of farming. The Strict Baptist (Particular) creed survived opposition in such retreats as the Vale of Olchon, and western outposts like Rhydwylym. Subsequent movement westwards (root crops and seafaring commerce) to N.W. Pembrokeshire. The coincidence of Baptists and dark broad-headed men in this area, studied in the light of the characteristics of the latter and the tenets of the former, indicates a possible relation between the two in Wales.

(3) The dark long-headed stock-breeders of the remoter parts, untouched by Puritanism, were opposed to the Church of the Nordic squire and found expression through the Welsh language in the eighteenth century in the Calvinistic Methodist Movement. In mining areas Cornish miners exerted an influence for Wesleyanism.

(4) In South Cardiganshire, in a rural area, with a hyperdolichocephalic dark population, Unitarianism has dominated almost to the exclusion of all other faiths.

Miss M. McINNES.—*An Ethnological Survey of Sheffield and the Surrounding District.*

A few years ago, in making an economic survey of Sheffield and the district around, a cursory glance at the workers seemed to offer material for an ethnological study. This was undertaken with interesting results.

Investigations on hair and eye colour of 2,200 school children in the outlying districts of South-West Yorks and North-East Derbyshire, and of 6,300 children in Sheffield itself, were recorded in the manner recommended by Beddoe. The methods for obtaining the Index of Nigrescence advocated by Parsons were preferably followed. The conclusions drawn were:—

1. That the Nordic types predominated throughout the area.
2. That the darkest children were found in the poorest and most congested industrial areas of the city.
3. That the farther away from the city the fairer the children became, both of hair and of eye.
4. That 'nests' of dark children remained here and there in the outlying districts, especially on the higher gritstone moorlands of the Don Valley headstreams.
5. That mixed types, also, were found oftenest in the crowded city areas, though they occurred throughout the city in greater numbers than in the outlying districts.

Investigations on adults confirmed these conclusions and, in the variations found, gave interesting points for future study.

Head and body measurements on adult town workers showed two types. The lighter cutlery and silver-plating trades employed, on the whole, a fairer, taller type than the heavy iron and steel works. The workers in the latter were stunted, longer of body, shorter of leg and darker of colour than those in the former. Both fell far below the average of the more leisured classes, where the tall, muscular, well-proportioned Nordic type was in the majority.

SECTION I.—PHYSIOLOGY.

(For references to the publication elsewhere of communications entered in the following list of transactions, see p. 433.)

Thursday, September 1.

Prof. B. A. McSWINEY.—*Observations on the Elasticity of Arteries.*

The velocity of the pulse wave has been measured with accuracy in man by the use of the hot wire sphygmograph and the relative extensibility of the arteries calculated from a simple formula. To determine how far differences of diastolic pressure

may be responsible for observed variations in the velocity of the pulse wave, a simple device was adopted. A bandage of known width was applied to a limb and the pressure of the bandage raised to p mm. of Hg; the effective pressure inside the artery was then not P , the blood pressure as usually observed, but $P-p$. The pulse velocity can then be measured at varying effective pressures. A curve has been drawn relating the effective pressure to the arterial extensibility.

Mr. C. J. BOND, C.M.G.—*On the Effect of Certain Radiated Lipoids on the Cellular Constituents of the Blood.*

When blood is incubated in a closed cell on an ergosterol film, half of which has been exposed to U.V. rays from a mercury vapour lamp, the red blood corpuscles in the radiated area undergo hæmolysis, while leucocytic emigration is also stimulated, and the leucocytes show marked changes.

This agglutinative and hæmolytic effect on the red cells can be used as a test for the presence of radiated fatty substances in smears or extracts from organs and tissues, in blood serum and in other materials.

Thus, while lanolin and some other fats give a similar result to ergosterol, extracts and smears from the cells of some animal organs give an opposite effect, and show the hæmolytic change in the non-radiated area of the film. Of the organs so far examined, smears from liver cells give the most marked results.

Radiated Blood Serum.

Some blood serum (C.J.B.) was evaporated to dryness in the cell of a hollow-ground slide. Half the film of this desiccated serum was then exposed to the U.V. rays from a mercury vapour lamp for half-an-hour. The whole cell was then filled with a suspension of washed native red cells in normal saline, and sealed with a cover glass.

On standing, the red cells undergo agglutination over the whole film, but much more so in the radiated part.

Blood serum so treated by concentration and radiation thus acquires the property of agglutinating native red cells.

Further experiments show that, by concentration in air and by subsequent radiation, the blood serum of an individual belonging to one blood group can be converted (as regards agglutinating capacity) into that of another group.

This change in the blood serum can also be brought about by repeated agitation in a test tube, in contact with air.

In the same way blood serum which has been evaporated to dryness in the air retains its increased agglutinative capacity when redissolved in serum or in N.S.

By the use of concentrated and radiated blood serum, it is possible to show on the same film the presence of rouleaux-formation, agglutination, and hæmolysis. Light is thereby thrown on the nature of hæmagglutination.

Prof. H. S. RAPER, C.B.E.—*The Direct and Indirect Oxydases.*

Recent investigations on the action of tyrosinase have shown that from the phenols and allied substances on which it acts ortho-quinones are produced. In certain instances these turn guaiacum tincture blue without addition of hydrogen peroxide. Since a similar production of ortho-quinones may take place in plants under the action of tyrosinase, which itself does not turn guaiacum blue, the guaiacum reaction is not a correct indicator of the presence of 'direct oxydases.' The classification of oxidising enzymes based on the guaiacum reaction is, therefore, fallacious.

A study of other reactions which may be used to distinguish these aerobic oxidising enzymes leads to the conclusion that up to the present only two have been shown to exist, namely, tyrosinase and peroxydase. The direct blueing of guaiacum shows only the presence of certain peroxides or an oxidation system that can produce them in presence of air.

Prof. J. W. McLEOD.—*Variations in Respiratory Mechanism amongst Bacteria.*

Dr. E. R. DAWSON.—*The Action of Pancreatic Lipase, I.*

The effect of phosphates on the hydrolysis of esters by pancreatic lipase varies according to the method of preparation of the enzyme. In some circumstances a simple relationship is observed between the activity of the enzyme and the concentration of phosphate ions.

Mr. B. S. PLATT.—*The Action of Pancreatic Lipase, II.*

An attempt has been made to define the conditions for synthesis of esters by pancreatic lipase. The methods used to estimate the amount of synthesis will be described. The state of the preparation appears to modify the behaviour of the enzyme when water-soluble esters are being synthesised. The synthesis of true fats presents some differences which may bear on the question of re-synthesis in the body of the products of fat digestion.

Miss MARION HIRST and Dr. C. G. IMRIE.—*Some Observations on the Excretion of Creatine.*

Dr. E. J. WAYNE.—*A Contribution to the Study of the Oxidation of Fatty Acids in the Body.*

For several reasons it was considered possible that fatty acids might be oxidised in part by some mechanism other than by a series of β -oxidations, and a quantitative examination of the fate of a series of normal phenyl fatty acids has, therefore, been carried out. Those containing an odd number of carbon atoms in the side chain appear in the urine exclusively as benzoic acid, those containing an even number as phenylacetic acid. The amounts obtained indicate quantitative β -oxidation among the lower members with the possibility of some additional mechanism among the higher members of the series.

Mr. E. N. WILLMER.—*The Influence of the Medium on the Multiplication of Cells growing in vitro.*

Friday, September 2.

Presidential Address by Dr. C. G. DOUGLAS, C.M.G., F.R.S., on *The Development of Human Physiology.* (See p. 155.)

Discussion on *Circulation Rate.*

(a) Dr. H. WHITRIDGE DAVIES.

(b) Prof. B. A. McSWINEY.

(c) Mr. H. BARCROFT.

Dr. W. CRAMER.—*The Requirements of the Population in Milk-fat (Vitamin A) and the available Supply.*

AFTERNOON.

Excursion to Harrogate.

Monday, September 5

Dr. A. D. MACDONALD.—*The Influence of Anæsthetics on the Action of Drugs.*

Dr. H. WHITRIDGE DAVIES.—*Some Observations on Hæmophilia.*

Investigation of the acid-base balance of the blood in a number of cases of hæmophilia revealed an appreciable degree of flattening of the carbon dioxide

dissociation curve. In other words, for a given increase in carbon dioxide pressure, the carbon dioxide content of the blood increased to a lesser extent than in the bloods of normal individuals. This indicated a deficiency of the buffering power of the blood, which, on further investigation, appeared to be due to an alteration of the normal ionic interchange between plasma and corpuscles. In addition, it was found that the clotting deficiency in hæmophilics seems to be due partly to an alteration in the permeability of the blood cells.

Prof. R. J. S. McDOWALL.—*The Effect of Mental Stress on Man.*

Of recent years a large amount of evidence has been accumulated regarding the effect of mental stress on man. Briefly, it may be stated that the general effect of such stress appears to be identical with that produced by exercise, and appears to be associated with general increased sympathetic activity which is specially well seen in the modification of the activity of the circulation and of the alimentary canal. In relation to the former, it becomes evident that there is an increased rate of the heart and vasomotor tone which together bring about a great increase in blood pressure. Small degrees of mental effort which even to the individual may appear insignificant can be shown to cause definite constriction of the blood vessels of the skin, and all degrees are found between this and the rapid cardiac action of which the individual is conscious.

In physical or mental stress there is now definite evidence that alimentary activity in general is reduced. Salivary and gastric secretion is markedly reduced, while there is marked delay in the emptying of the stomach. There is good reason to believe that such conditions may be largely responsible for many alimentary ailments, and may in part be responsible for undue strain on the circulation.

Dr. R. H. THOULESS.—*The Physics of the Psycho-Galvanic-Reflex Phenomenon.*

The electrical changes in the body which result from the physiological concomitants of emotion have been stated to be :—

- (a) A change in resistance.
- (b) A change in the back E.M.F. of polarisation.
- (c) A change in the difference between the potential of the skin at the two points to which electrodes are applied.

There has been a tendency for physiological investigators (Gildemeister, Prideaux, Sidis, &c.) to assume that only one of these changes really takes place, and that other investigators' reports of other changes are due to carelessness in interpretation of results or even to 'errors in logic' (Sidis).

Experimentation under different conditions of circuit shows that all three changes take place. The change in resistance is an increase immediately after the stimulus, followed by a larger decrease after a latent period of about 1.8 seconds. The change (c) has two forms. Sometimes it is a simple increase of the somatic current. At other times a very small increase is followed by a larger decrease, which is followed again by a still larger increase with very slow recovery. There is also a change in the polarisation produced by an external current, but this may simply be the secondary effect of the change in bodily resistance.

The electrical changes in the body produced by emotion are thus more complex than has generally been recognised by those who have proposed physiological explanations of them. An adequate physiological explanation of the phenomena must take into account the three changes in the somatic current which correspond probably to three different physiological events.

Prof. H. E. ROAF.—*The Effect of one Coloured Light on another with reference to Theories of Colour-vision.*

Dr. F. W. EDRIDGE-GREEN, C.B.E.—*The First Recorded Cases of Colour-Blindness.*

It is usually stated that the first definite record we possess of a case of colour-blindness is Huddart's account of the shoemaker, Harris, in 1777, but that great genius, Robert Boyle, in his 'Some Uncommon Observations about Vitiated Sight,' 1688, gives an account of two cases. The first case is that of a girl of about eighteen

or twenty years old. She stated that about five years previously, after having blisters applied to her neck and other parts, she was quite deprived of her sight. Robert Boyle continues 'that sometime after she began to perceive the light, but nothing by the help of it: That then she could see a Window without discerning the Panes or the Barrs: That afterwards she grew able to distinguish the Shapes of Bodies, and some of their Colours: And that at last she came to be able to see the Minutest Object.' After giving some further details, Robert Boyle continues:—'But the other, which is more Strange and Singular, is this, that she can distinguish some Colours, as Black and White, but is not able to distinguish others, especially Red and Green: And when I brought her a Bag of a fine and glossie Red, with Tufts of Sky-Colour'd Silk; she look'd attentively upon it, but told me, that to her it did not seem Red, but of another Colour, which one would guess by her Description to be a Dark or Dirty one: and the Tufts of Silk that were finely Colour'd, she took in her Hand, and told me they seem'd to be a Light-colour, but could not tell me which; only she compar'd it to the Colour of the Silken Stuff of the Lac'd Peticcoat of a Lady that brought her to me; and indeed the Blews were very much alike. And when I ask'd her, whether in the Evenings, when she went abroad to walk in the Fields, which she much delighted to do, the Meadows did not appear to her Cloathed in Green? She told me they did not, but seemed to be of an odd Darkish Colour; and added, that when she had a mind to gather Violets, tho' she kneel'd in that Place where they grew, she was not able to distinguish them by the Colour from the neighbouring Grass, but only by the Shape, or by feeling them. And the Lady that was with her, took thence occasion to tell me, that when she looks upon a Turkey Carpet, she cannot distinguish the Colours, unless of those parts that are White or Black.'

The second case is that of a mathematician eminent for his skill in optics who found, 'that there are some Colours he constantly sees amiss,' but no colours are mentioned by names, though an instance is given of a mistake.

Tuesday, September 6.

Miss W. J. WADGE and Mr. W. H. NEWTON.—*Rapid Colorimetric Method for Measurement of pH.*

The method consists of the neutralisation of British Drug Houses' 'Universal Buffer' with sodium hydroxide until its colour exactly matches that of the unknown solution, when the two are treated with equal volumes of a given indicator and examined in a colorimeter. A measured quantity of indicator is added to 1 cc. of 'Universal Buffer,' to which is added N/10 NaOH from a burette to the nearest 0.1 cc. before the colour matches that of the unknown. N/50 NaOH is added in the same way until the colours exactly match. The pH of the unknown is then read from a composite graph which shows the hydrogen-ion concentration of 'Universal Buffer' when given amounts of both N/10 and N/50 NaOH have been added. The range of the method is from pH 3.1 to pH 11.4.

Mr. A. WORMALL.—*Some Properties of Complement.*

The complement system consists of four factors, all of which are necessary for the hæmolysis of sensitised red cells. Two of these factors are heat labile and are destroyed at 56°C. in half an hour, while the other two are relatively heat-stable. The destruction of complement by yeast, ammonia, pancreatic extracts, acids and alkalis and ultra-violet rays, is due to the inactivation of one or more of these components, and the inactivated serum can be reactivated fully by the addition of the missing component or components. The properties of the separate components and the relationship, if any, between complement and the opsonic system of serum, are being investigated.

Demonstrations:—

- (a) Mr. G. WILKINSON.—*Model of Cochlea.*
- (b) Prof. B. A. McSWINEY and Dr. BERENBLOOM.—*Apparatus for regulating pH of Solutions for Smooth Muscle Experiments.*
- (c) Miss W. J. WADGE.—*Methods for determining H-ion Concentration.*
- (d) Dr. H. W. DAVIES.—*Apparatus for Oxygen and CO₂ Administration.*

SECTION J.—PSYCHOLOGY.

(For references to the publication elsewhere of communications entered in the following list of transactions, see p. 434.)

Thursday, September 1.

Joint Discussion with Section L on *The Psychology of Special Scholastic Disabilities*. Miss G. HUME, Miss E. WHEELER, and Miss A. H. McALLISTER.

MISS G. HUME.—*Disability in Reading*.

The Complexity of the Reading Process.—Reading is a highly complex activity, involving the acquisition of skill in the mechanics of the process and also the ability to comprehend meaning. Acquisition of the mechanics of reading depends upon the ability to perceive and synthesise the contributions received from the eye, the ear and the muscles. Ability to comprehend what is read involves the apprehension of the right relations between the various elements of the sentence.

Ability to acquire the mechanics appears to be more loosely correlated with intelligence than ability to comprehend meaning.

An Investigation into Backwardness in Reading among Elementary School Children in London.—Selection of cases; definition of reading ability; below 85 per cent. of mental age; method of study, intelligence tests, educational tests, trait rating schedule, personal history. Analysis of results obtained: (a) frequency of cases, 2·3 per cent.; (b) causes, (1) extrinsic 50 per cent. of the cases—*e.g.* irregular attendance, low culture or poor vocabulary at home, physical defect in early childhood, inappropriate teaching methods, emotional disturbance, *e.g.* shock or fright; (2) intrinsic, *e.g.* (a) weak specific ability, *i.e.* weakness of immediate or long-distance memory for verbal symbols, inability to discriminate between simple letter and word forms, &c.; (b) innate emotional instability.

Disability, however, is not a simple but a complex condition, and is commonly due to a plurality of causes.

Illustrations from individual cases.

Conclusions and suggestions for pedagogical treatment.

MISS E. WHEELER.—*Backwardness in Arithmetic*.

An investigation into backwardness in arithmetic was carried out in sixteen elementary schools. In twelve of these schools cases of special backwardness in arithmetic were selected by the head teachers; in the remaining four schools cases of backwardness were determined by means of tests of intelligence, and educational attainments, given to the whole school. Certain selected cases were studied with a view to discovering the causes of backwardness.

They are classified as follows:—

1. Conditions in the child's environment as they affect not only his background of experience, but also his emotional life.

2. Physical conditions—physical defect—nervous conditions, &c.

3. School conditions—defective school organisation—teaching methods unadjusted to needs of exceptional individuals.

4. Intellectual disabilities—defects of 'attention,' memory, &c.

5. Temperamental difficulties—emotional instability—general apathy.

General conclusion—emotional factors seem to be most potent in producing and maintaining a condition of backwardness.

MISS A. H. McALLISTER.—*Speech Disabilities*.

An investigation into the speech of 21,000 school children, made for the purpose of finding the frequency of speech disabilities and their effect upon educational progress, showed that 5·6 per cent. were suffering from some form of speech disability, and that of these 70 per cent. fell below the class average in scholastic attainment. There was a distinctly greater proportion of disability at ages six to seven and eleven

to twelve years, and it was about twice as frequent among boys as among girls at all ages. All speech defects, except stammering, were less frequent at the higher ages; the proportion of stammerers among the seniors (age eleven years) was twice as great as among the infants (age six), and it was twice as great among boys as among girls.

Clinical records suggest that speech disability is as frequently the cause as the effect of mental disorder. The defects which call for special attention in this connection are imitated defects, which are most difficult to cure and emotionally most disturbing, and defects due to organic malformation or to delayed development which rouse feelings of inferiority as soon as the individual becomes aware of them. The most common causes of stammering and stuttering among young children appear to be fear, anxiety, jealousy—*e.g.* of a younger brother or sister—thwarted desire and bad teaching.

Among the many causes of indistinct and badly articulated speech must be reckoned low sensitivity to pitch differences. An investigation of the speech of 200 women revealed a correlation of 0.73 between sensitivity to pitch and amount of improvement in speech.

Dr. J. DREVER.—*Meaning.*

Dr. LL. WYNN-JONES.—*The Appreciation of Wit.*

The distinction between the psychology of the wit and that of the appreciator of wit in others may sometimes profitably be made. The divergence of views regarding the former is well known, *cf.* Locke, Hazlitt, Bergson, Freud, &c. But even with regard to the latter, which is the subject of this paper, various beliefs are current. Most, however, would agree that one characteristic of witty, as distinct from humorous, stories is the pause of varying length during which the point of the story becomes manifest.

Two series, each of eighteen paragraphs, involving sound-wit, play on words, caricature, characterisation wit, repartee and incongruities were shown to elementary school children (Standards 5 and 7), to secondary school children (Form 5), and to university graduates. The stories were short, for not only is brevity the soul of wit, but the exigencies of experimentation also demand it.

It is sometimes held that wit is relative, not only to class, but also to locality; but a preliminary survey seems to indicate that locality as such plays an insignificant part, if any, in comparison with the paramount factor of 'g.' Lack of comprehension of written words and phrases makes it very difficult for children in Standard 5 to appreciate the majority of witty stories.

A characteristic of all groups is that when the point of a story is not manifest there is an active search for a clue and an irrelevant solution is often accepted. In many cases, however, these solutions are highly ingenious.

The marking of such tests is not so rapid or 'fool-proof' as in most group tests, but a counterbalance is the greater insight into personality. Greater still is this insight when they are used as individual tests.

Mr. E. FARMER.—*Certain Psychological Aspects of Accident Causation.*

The statistical work of Yule, Greenwood, and Newbold has shown that the distribution of industrial accidents among individuals exposed to the same risk is not such as can be explained by chance. The typical curve of accident distribution is U-shaped, with a large number in the group having relatively few accidents and a small proportion having an undue number. The hypothesis that best explains this distribution is that each person has a given degree of accident proneness that will determine to a large extent the number of accidents he will sustain in a given period of exposure.

Tests have been carried out by the Industrial Fatigue Research Board with the object of determining what are the personal qualities connected with a high accident rate. Several hundred subjects have been tested and the preliminary results published. These indicate that subjects who do badly in certain sensory-motor tests also tend to have a larger number of accidents in a given period of equal exposure than those who do well in the tests. The difference in accident rate between those above and below the mean for the 600 subjects tested during the investigation was 48 per cent. This

group of sensory-motor tests has been called 'æsthetokinetic tests,' because they intercorrelate among themselves in a small degree and also have the common factor of requiring a visual, auditory or tactual stimulus to be reacted to by a movement requiring rapid and accurate co-ordination.

Certain tests connected with temperamental instability have also shown a relationship to accident incidence, but on account of certain difficulties in scoring they were not included in the final weighted score. Their use will probably be greatest in deciding cases left doubtful by the other tests.

No relation has up to the present been established between intelligence and accident rate, but the data on which this conclusion is founded are not so extensive as that yielded by the æsthetokinetic tests, and further research is being carried out to elucidate this particular aspect of the problem.

The conclusions arrived at by the Industrial Fatigue Research Board are admittedly preliminary, and much further work needs to be done before results obtained by this method can be regarded as of practical value. Sufficient, however, has been done to show that inequality in accident rate is a personal measurable quality, and future research must be directed towards determining to what extent it can be measured and by what tests the best measures can be obtained. The Industrial Fatigue Research Board is at present engaged in an extensive research along these lines, but several years must elapse before the results can be properly appraised.

Friday, September 2.

MR. R. J. BARTLETT.—*Feeling and the Psychogalvanic Reflex.*

The 'emotion' theory of the 'reflex' has been challenged by a 'conation' theory. The experimental basis of neither theory is fully conclusive. Attempts have been made to secure under experimental conditions mental states in which, unequivocally, 'feeling' should be the dominant factor in experience. Experiments will be described and results submitted to demonstrate that the 'reflex' follows a variety of complex mental states, some at least of which include a phase that would ordinarily be described as 'feeling,' and that differences in the form of tachogram record provide an objective basis for classification of these complex experiences.

DR. R. H. THOULESS.—*Fechner's Law.*

Fechner's law is a valid method of measuring sensation over the range for which Weber's law is true. His central step of treating just noticeable differences of sensation as equal is, however, to be regarded as a convention of measurement.

DR. D. N. BUCHANAN.—*The Psychological Effects of Flickering Light.*

DR. F. W. EDRIDGE-GREEN, C.B.E.—*The Classification of the Colour-blind.*

There are probably no subjects in science in which there are more misstatements than in vision and colour vision. A classification of the colour-blind should, therefore, be made only on facts; this classification can easily be made with the aid of my spectrometer, with which any portion of the spectrum can be isolated.

Cases of colour-blindness may be divided into four distinct classes, each of which may occur separately or they may be combined. These classes are (1) Defective hue discrimination, (2) Defective light perception, (3) Defective perception of colour through the foveal or central region of the retina not being normal, or supplied normally, (4) In this class, while there is no defect in colour discrimination or defective light perception, one or more colours do not occupy the normal position. For instance, the position of pure yellow instead of being at .585, as in the normal sighted, is in the yellow-green or orange-yellow. These cases can hardly be called colour-blind, but are really colour different, but have to be taken into consideration in testing colour-blindness for a practical object.

Defective hue discrimination may be classified according to the number of colours which are seen in the spectrum, check examinations being made to prove that the examinee sees as described by him. One man will declare that there is no difference in colour over the whole spectrum but simply variations in brightness; another will

say that the spectrum is tinged with red at one end and violet at the other, the central portion of the spectrum being colourless; another that the spectrum consists of two colours, red and violet, with a small colourless interval; another that the spectrum contains three colours, namely, red, green, and violet, the orange and yellow regions being designated red-green and the blue region green-violet. Another will say that he sees four definite colours, others five or six and a few seven. It will be seen that our colour sensations are very limited, the person having the most acute colour perception only having seven definite colour sensations. We can, therefore, classify the colour perception of individuals as achromic, dichromic, trichromic, tetrachromic, pentachromic, hexachromic, and heptachromic.

The term 'dichromic' is applied to those who have only two definite colour sensations and white. When examined with a bright spectrum, they say that they see only two colours there. In the same way the designations trichromic, tetrachromic, pentachromic, hexachromic, and heptachromic, are applied to those who see in the bright spectrum three, four, five, six or seven colours. Those examined behave in every way as if they possessed the number of colour sensations indicated.

All Dichromics are not equally Colour-Blind.

A fact that seems to have been generally overlooked is that colour-blindness found in dichromic vision is a defect of hue perception, and that it is this defect of hue perception which causes the characteristic symptoms of colour-blindness.

The colour perception of the dichromic varies from those who have a colour perception bordering on the trichromic to those who are almost totally colour-blind. It is obvious that a man who cannot see the least difference between the colour of the red and that of the green signal on the railway line, except when one is changed to the other, has a colour perception which is more defective than that of the ordinary dichromic. Though I have never found a dichromic who had a hue perception equal to that of the trichromic, I have examined many who possessed a hue perception which was nearly equal.

Trichromic vision is quite distinct from the so-called anomalous trichromatism, ninety per cent. of the colour-blind agree with the normal equation.

Abnormalities and defects of light perception may be subdivided as follows:—

1. Increase or diminution in the visible range of the spectrum.
2. Defective sensibility for certain wave-lengths.
3. Increased sensitiveness for certain wave-lengths.
4. Variations in the maximum of the luminosity curve.
5. Increase or defects in the power of dark adaptation.

(a) Very rapid or slow dark adaptation.

(b) Very complete or imperfect dark adaptation.

It will be seen that the terms used in previous classifications are quite meaningless; for instance, a so-called typical red-blind is a dichromic with a considerable shortening of the red end of the spectrum, but this shortening may be associated with normal hue differentiation, and scarcely two cases agree in the amount of shortening.

Mr. C. A. MACE.—*Factors Determining 'Natural' Rates of Mental and Physical Work.*

The specific questions from which an extended course of investigations has arisen were (1) To what extent is the ratio of 'natural' to maximum rates of working constant? and (2) Is the natural rate of working more efficient than any prescribed rate?

Provisional answers, limited in application, have been obtained. (1) The ratio is far from constant, but at natural rates of working the individual's measure is sometimes more constant, and individual differences more marked. Hence it is desirable that more mental tests should be standardised for both rates. (2) The greater efficiency sometimes observed with subjectively preferred rates of working is a transient phenomenon disappearing with practice. In general a law of inverse variation between speed and accuracy appears to hold over a wider range than has been supposed.

On the more general questions which arose suggestive observations were made in the course of the inquiry. On the basis of these observations further investigations have been opened up which promise to elucidate the distinction between abilities proper and temperamental traits.

Mr. D. KENNEDY-FRASER.—*The Use of the Elements of School Instruction in Psychological Investigation.*

A scheme is being devised whereby the elements of number work and reading may be used in making psychological investigations under school conditions and for diagnosing specific school disabilities. A series of tests is being formed in which both the stimulus and the response involve either number or reading elements in such a way as to discover any peculiar difficulties in forming associations between different sensory categories. Illustrations from the results so far obtained indicate some hitherto unsuspected sources of difficulty in the learning of number and reading and point to some probably fruitful lines of further psychological and educational research. This method may also form the basis of a number or reading 'profile' for beginners or those who are experiencing difficulty in acquiring these forms of skill.

Miss M. M. MACTAGGART.—*Some Causes of Backwardness.*

This paper is based on the results of an examination of backward children of ages eleven to twelve (the Scottish Qualifying Stage). The aim of the investigation was to find the percentage of pupils whose retardation in school work was the result of unsuitability of curriculum rather than of low intelligence.

The procedure was to find the Mental Age, Intelligence Quotient, Educational Age, and Accomplishment Quotient of each retarded pupil. The accomplishment quotient, which is the ratio of the educational age to the mental age, ought to be 100 if the child is working up to his innate ability. It was considered satisfactory if it was over 95.

Fifty-eight per cent. of the backward children had accomplishment quotients of 95 or more; they were, therefore, working at or above their innate ability. Their scholastic performance, in spite of this, was distinctly inferior to that of normal children of the same age. The cause of their backwardness was, therefore, low intelligence.

Of the remainder 8 per cent. were backward for other reasons, *e.g.* weakness in a specific subject, poor home circumstances, bad health. The remaining 34 per cent. were mainly of normal intelligence or only slightly retarded; some were even of superior intelligence. To find whether their weak educational ability was compensated by non-scholastic ability and out-of-school interests, they were examined by three sets of non-scholastic tests specially constructed for this purpose—technical information tests, picture tests, and a practical test. The performance of 27 per cent. of them in at least one of the special tests was superior to their educational performance: while they did not respond to the ordinary school curriculum, they were keenly interested in practical, technical, and mechanical subjects. The cause of their retardation in school was apparently unsuitability of curriculum.

Mr. H. LOWERY.—*The Musical Ability of School Children.*

Music appears to be, *par excellence*, that subject in which tests of native ability should be most successful, since the possession of musical gifts is usually regarded as a special endowment.

It is desirable that tests of musical ability should draw upon music for their material, and, in the framing of such tests, it is important to distinguish between the technical and interpretative sides of musical performance.

The test of 'musical memory' now presented consists of fifty examples made up from variations of ten musical themes in ways suggested by the compositions of the classical composers, together with musical phrases having no connection with these themes. Judgments are to be given as to whether or not the examples in the test seem to the subjects to be founded on the ten original themes.

The following distribution was obtained with thirty-six girls (twelve to fourteen years of age):—

Number having	80% to 100% correct (highest mark 90%)	. . .	2
"	" 70% " 79% "	. . .	9
"	" 60% " 69% "	. . .	17
"	" 50% " 59% "	. . .	7
"	" less than 50% correct (lowest mark 48%)	. . .	1

The votes for the individual examples of the test afford material for remarks on transposition, augmentation, diminution, ornamentation, and other elements which contribute to the development of a musical composition.

Monday, September 5.

Presidential Address by Dr. W. BROWN on *Mental Unity and Mental Dissociation*. (See p. 167.)

Dr. H. RUTGERS MARSHALL (the late).—*Self-consciousness and the Self*.

(I) We speak of our conscious experiences as presentations to the Self of the moment of apprehension, and we accept Ward's conception of the presentation-continuum. The Self is part of the consciousness of the moment, but being that part to which the mental items are presented, cannot itself be part of that presentation. Its nature can only be known by indirection. But it would seem likely to prove to be a continuum. But in our experiences of *self-consciousness* the mental item presented consists of an Ego to which a presentation is given—a complex presentation given to the Self. This Ego being part of the presentation cannot be the Self, although commonly spoken of as such. Furthermore, this Ego appears to be an empirical thing. That we commonly call it the Self suggests that it may be a simulacrum of the Self.

This empirical Ego is evidently a changeable thing, and if it is a simulacrum of the Self, the Self must be a changeable thing. Objective evidence favours this view, as a man's character is known to change as he develops, and his Self is an essential part of his character.

(II) Further light is gained if we consider the nature of the neural activities that are found to correspond with changes in consciousness. The neururgic system is all active, in each moment being a complex pulse of activity. A 'special activity' in a part is rather an emphasis of activity in that part. It appears as an increment in contrast with the whole mass of undifferentiable parts of the total neururgic pulse, which is changed by each increment. When a presentation occurs it corresponds with a neururgic increment; a presentation, therefore, may be looked upon as a psychic emphasis within a whole psychic pulse, which pulse appears as an increment in contrast with the whole mass of undifferentiable psychic parts. But the Self is a psychic somewhat to which the presentation accrues as an increment. Hence the Self of any moment would appear to be this whole mass of undifferentiable psychic parts.

This indicates that the Self, while a continuum, is not a persistent entity. As presentations change, so must the whole psychic mass—presentations *plus* the Self—change. The Self of each moment is a new Self. The empirical Ego then appears as a simulacrum of the Self.

(III) In cases of choice we are dealing with the comparison of two diverse empirical Egos, either of which, if it prevailed, would act in a determined manner, and yet be free to act in accord with its essential nature. Right conduct is then dependent upon the nature of the prevailing Ego—in the end upon knowledge. There is no such thing as voluntary unreasonable action; no such thing as sinning. What we have is recognition that we have sinned or might sin; have acted or might act as the prevailing empirical Ego would not act. And this is of the essence of ethical advance.

Dr. T. W. MITCHELL.—*Phenomena of Mediumistic Trance*.

Dr. G. H. MILES.—*Time and Motion Study as Employed by the Industrial Psychologist*.

The Industrial Psychologist attempts to evaluate the physical and mental demands on the worker at each stage of the operations which he is timing. He also studies the movements made and endeavours to reduce the strain by simplifying these. Thus to the psychologist the effect on the individual is of more significance than the time value of an operation or a pause during that lapse of time. A pause in an operation is, from a pure time-study point of view, a waste of time, and if the human being

were a machine, it would be necessary to eliminate or reduce this unproductive time. The psychologist, however, must consider whether this pause is, or is not, serving some useful purpose in giving adequate rest to the workers' efforts.

A time study directs attention successively to important features in a cycle of operations, and the completed study gives a picture of such a cycle. It is essential to estimate from the picture so obtained what points are of fundamental importance before proceeding with a detailed study of a portion of the cycle. Thus it may be important first to reduce the strain which may be imposed on a worker owing to unnecessarily divided attention, or to the faulty supply of material, and then proceed to a more detailed study of, for example, finger movements.

During movement study it is important to determine what movements are unnecessary. From a mechanical point of view many movements which a worker makes appear to be quite unnecessary. Yet from a psychological and physiological point of view these movements may be useful to give relaxation, to assist in the blood flow, or to fill in some portion of a rhythm or cycle of movements. Instances occur in which fatigue may be lessened by actually increasing the number of movements made.

In order to ascertain whether the increased rate of working produced as a result of movement study is likely to be beneficial to the worker in the long run and is not a mere temporary speeding up, the Industrial Psychologist time-studies the altered method of working, and from the work curve obtained he estimates the true value of the new method.

Time studies of a group working on a series of operations often indicate inequalities of effort. One or more members of the group may be unduly pressed and the Industrial Psychologist attempts to equalise the strain by regrouping or subdividing operations and redistributing duties.

Time and movement study enables the Industrial Psychologist to ascertain where human energy is being misapplied and to correct these. It also provides the means of checking the value of alterations which may be introduced to avoid waste and undue fatigue.

Mr. S. WYATT.—*Machine Speeds and Output.*

Mr. J. A. FRASER.—*The Value of Stoppage Analysis with special reference to Weaving.*

Voluntary and Involuntary Stoppages.—The number, duration and distribution of voluntary stoppages may reflect upon working capacity at different times throughout the day, and may also throw light upon the way in which the worker is affected by changes in environmental conditions. A study of involuntary stoppages may give information as to the effect upon efficiency of such factors as method of organisation, type of machinery, quality of material, &c.

The Stoppage Analysis in Weaving.—Here we are dealing mainly with unavoidable loom stoppages. The ability of the weaver is largely dependent upon the speed with which she performs certain standard operations. When loom stoppages occur, a study is made of the nature and duration of each loom stoppage. Thus, in weaving, a stoppage analysis is virtually a 'time-study.' Some stoppages, however, may be due to factors such as carelessness on the part of the weaver, desire for relaxation, &c., and those same causes may be responsible for undue prolongation of loom stoppages. A stoppage analysis in weaving may provide data upon which to base (a) an explanation of variations in efficiency throughout the day; (b) a study of the relative efficiency of different methods adopted by weavers with a view to selecting the most efficient methods and training young weavers accordingly; (c) conclusions as to the special abilities which underlie efficiency in weaving with a view to framing a scheme of selection; (d) conclusions as to the effect upon efficiency of the mechanical factor, quality of the warp and the weft, method of organising supplies; (e) evidence as to the effect upon the worker and upon the yarn of changes in environmental conditions such as temperature and humidity.

Selection and Training.—Classification of abilities necessary to efficiency in weaving. Some principles of method underlying efficiency in weaving. Suggestions as to selection tests. A joint scheme of selection and training.

Tuesday, September 6.

Joint Discussion with Section F on *Innate Differences and Social Status*.

Dr. M. GINSBERG, Prof. GODFREY H. THOMSON, and Mr. F. C. BARTLETT.

Dr. W. R. D. FAIRBAIRN.—*Religion and Fantasy*.

The researches of the psycho-analytic school have led to the theory that religious phenomena are symbolic expressions of primitive instinctual forces to which overt expression has been denied for social and cultural reasons. These primitive forces remain active at unconscious levels, and reach consciousness usually in disguised and sublimated forms, of which the most important are the religious and the artistic. Two main conclusions have been reached regarding the origin of the religious urge in its psychological bearings:—

1. The religious attitude is the sublimated expression in the adult of an infantile attitude toward the parents, who appear to the child as omnipotent.

2. Religious practice is directed towards the removal of a sense of guilt, which has its ultimate origin in the Œdipus Complex, *i.e.* the childish desire to possess the Mother at the expense of the Father.

A study of religious fantasies in the neurotic and insane provides evidence in favour of these theories.

Acceptance of these theories regarding the origin of the religious urge does not involve the discrediting of religious values, for the nature of Truth is a separate question from that of its origins. Further, these theories enhance rather than detract from the importance of the rôle played by religion in the transmutation of man's primitive instinctual forces into higher cultural forms of activity.

Prof. C. W. VALENTINE.—*The Comparative Reliability of Intuitive Judgments of Men and Women*.

Dr. H. R. DE SILVA.—*Experimental Control of Introspection*.

Mr. G. G. CAMPION.—*The Organic Growth of the Concept as one of the Factors in Intelligence*.

SECTION K.—BOTANY.

(For references to the publication elsewhere of communications entered in the following list of transactions, see p. 434.)

Thursday, September 1.

Presidential Address by Prof. F. E. FRITSCH on *Some Aspects of the Present-day Investigations of Protophyta*. (See p. 176.)

Prof. J. LLOYD WILLIAMS.—*Some Parasites of the Phaeophyceae*. (Communicated in title only.)

Miss E. M. REES.—*Observations on the Structure and Reproduction of Bifurcaria tuberculata, Starckh*.

The genus *Bifurcaria* includes three species, all of very restricted range; of these *B. tuberculata* only is British.

The distribution, habitat and habit of *B. tuberculata* are described, and reference is made to the remaining two species, *B. brassicæformis* and *B. levigata*, both of which are South African.

Little is known of the British species since the work of Grüber on the mode of branching of the shoot, and of Nienburg on the development of the conceptacle.

Observations have been made from living plants and from material preserved *in situ* at different times of the year.

The development of the conceptacle from a single initial cell is shown, and the retention of a single basal hair up to the time of formation of antheridia is a conspicuous feature of the young conceptacle. The production of antheridia and oogonia is described, and the formation of 'plugs' at the mouths of old conceptacles reported—a phenomenon similar to that described by Tahara for *Sargassum Horneri*.

The genus as a whole is characterised by marked vegetative activity, new fronds arising from the rhizome and, especially in *B. levigata*, by proliferation from the bases of old stipes. The anatomy of the stipe is described for the three species; in *B. tuberculata* the anatomical relationship to the other genera of the group Cystosiro-Sargassæ is evident, while this is less clear in the two South African species.

MR. W. T. MATHIAS.—*The Cytology of Callithamnion.*

The paper deals primarily with the stages of nuclear division undergone during the development of the tetraspores of *Callithamnion brachiatum*. The resting nucleus is described and the stage where synapsis occurs is indicated. The various steps in division are unlike those described for other red algæ, and the diploid chromosome number is 18-20, in the tetraspore mother cell, this number being reduced to 9-10 in the mature tetraspore.

The development of the spermatia in this species is also described, and the nucleus of the mature spermatium is shown to be a homogeneous hollow band of chromatin encircling the cell, and not a granulated network as it has been described.

The cytology of abnormalities in *Callithamnion tetragonum* is also traced, and shows that tetraspores borne on sexual plants develop and mature, while the carpospores possess the Haploid chromosome number, suggesting cytological instability, and a more complicated alternation of generations.

MR. A. MALINS SMITH.—*The Algæ of a Bog: Five Years' Observations.*

The algæ of a small sphagnum bog have been examined, approximately monthly, for five years. Records of temperature and hydrogen-ion concentration of the water, as well as observations of the weather conditions and of the flow of the water, have been periodically taken. Chemical analyses of the water have also been made. The results shed light upon the specific composition of the alga-flora of such waters, the relative abundance and interdependence of the chief groups of algæ, and the periodicity of the various species. The relation of the alga-flora to the phanerogamic flora is briefly considered, and the status of the upland sphagnum bog as a habitat for a definite algal association is estimated. Comparison is made with the alga-flora of lowland pools and montane lakes.

Prof. N. E. SVEDELIUS.—*The Cytology and Development of Asparagopsis armata.*

The general morphology of this alga has already been described by Conolly. Observations now have been made especially regarding the cytology and the development of the cystocarp. Tetraspores are not known. The carpoconial branch is 3-celled, just as in *Bonnemaisonia*. The carpoconium at an early stage is binucleate, as in most Florideæ. Spermatia are to be seen adhering to the trichogyne and also inside them. Fertilisation thus certainly occurs. The number of chromosomes in the spermatia is at the most ten. Seven to eight have been observed with certainty; but probably there are some more. To determine the number exactly is very difficult owing to the smallness of the nuclei. The haploid chromosome number is then at most ten.

The carpospores are not produced as directly as in *Bonnemaisonia*, since the sporogenous filaments branch and in the first place form an extensive tissue, a so-called 'nucleus,' from which later on the carpospores are formed.

In the mitoses in the young sporogenous filaments a chromosome number of about eight has been observed. Thus the carpospores also must be haploid. *Asparagopsis*, then, is certainly a haplobiontic alga.

This quite naturally explains the absence of tetraspores and tetrasporic plants.

Where the reduction-division occurs is not yet settled with absolute certainty. It either occurs immediately after fertilisation—probably, however, not in the carposporium itself—or else there are a number of divisions of the diploid nucleus, followed eventually by several reduction-divisions. At the moment it has not been settled which of these two possibilities really holds good. This must be decided in the future. It is, however, a fact that *Asparagopsis armata* must be classed among those Florideæ which the author has designated as haplobiontic.

In the opinion of the author the Florideæ should be divided into two main groups:—

I. *Haplobionticæ* or haplobiontic types, and

II. *Diplobionticæ* or diplobiontic types.

To the former belongs with certainty the majority of the group Nemalionales; and it may be that the concept haplobiontic Florideæ coincide with the group Nemalionales.

We must always keep in view the possibility of finding the haplobiontic condition among the remaining Floridean families. If this results from apogamy it is of no systematic value. If, on the other hand, it is primary, depending upon the place of occurrence of the reduction-division, it is of great systematic importance.

It must be emphasised that the Florideæ are remarkable among the members of the vegetable kingdom in the fact that the place of occurrence of the reduction-division—in other plants quite fixed—is different in the different main sub-groups.

It is not impossible that future cytological investigation of the Red Algæ may offer us new types regarding the place of the occurrence of the reduction-division.

However this may be, one thing is certain: the future taxonomy of the Rhodophyceæ will demand cytological investigations to a very high degree.

AFTERNOON.

Excursion to Bramham Park.

Friday, September 2.

Joint Discussion with Section M on *The Control of Plant Diseases*.

Mrs. N. L. ALCOCK.—

(1) *A short review of past measures in the control of Plant Diseases in Great Britain and how far successful.*

The rise of American gooseberry mildew. Prof. Salmon's warning against American gooseberry mildew and wart disease. Prof. Somerville and white pine blister rust. The saving of the situation as regards wart disease by the discovery of the immune varieties. Action that succeeded—methods that have not succeeded.

(2) *The present point of view and present administration of control. The essential factors for success in control are:—*

(a) The convinced and willing co-operation of growers. This implies their share in framing legislation.

To attain this end clearness in exposition and ability to see the point of view of the grower and realisation of the business value of all control measures must go hand in hand with scientific efficiency in administration.

(b) Accurate scientific knowledge on the part of those administering control.

(c) Moderation in policy when framing rules and regulations for ordinary occasions, and brevity and conciseness in all exposition of such rules.

(d) Drastic measures for extraordinary occasions.

(3) *Some questions for the future.*

Plant disease control in *Agriculture*.

Margin of profit here small. Methods must be (a) certain, (b) easy, (c) cheap. Examples—Bunt and Formalin.

Seed-borne Diseases.

Some 70 common diseases carried on seeds. Research needed on treatment.

Horticulture.

Plant disease control more promising in horticulture. Margin of profit higher. More labour available. Plant sanitation essential. Prevention better than cure.

Forestry.

Prevention of disease in nurseries and inspection and control of importation.

Dr. WILLIAM B. BRIERLEY.—

(1) *Scope of Discussion.*

(2) *Research Aspects.*

(A) *Centres of Research.*

(i) Source, training and supply of men. Financing and staffing of laboratory, field and administrative services.

(ii) Types of research centres. Gradation from pure to applied work. Universities, research foundations, crop stations, government and extension services, commercial services. Source of moneys and type of centre in relation to scope of work, integration and administrative control.

(B) *Fields of Research.*

(i) Principles of control. Disease surveys; plant hygiene and sanitation; plant protection; escapement of disease; exclusion of disease. Effectiveness of methods in relation to expense, social, economic and political implications.

(ii) Some primary general issues.

(3) *Applied Aspects.*

(A) *Popularisation of Knowledge.*

Oral instruction, field service, printed matter. Relative values of the several avenues.

(B) *Application of Knowledge.*

Liaison mechanisms; official, commercial, institute and extension, *ad hoc*, personal.

Comparative values of the several mechanisms in relation to types of knowledge and practice. Suggestions regarding organisation.

(4) *Essential problem for discussion is the integration of practice and research.*

MISS E. WELSFORD, Dr. M. WILSON, Dr. W. G. SMITH, Mr. W. A. MILLARD, Dr. STOREY.

Dr. J. P. LOTSY.—*Demonstration (during the above Discussion) of Natural Hybrids between Plants and between Human Races in New Zealand and South Africa.*

Prof. J. McLEAN THOMPSON.—*Sterility and Gigantism in the Lecythideæ.*

An attempt is made to show that in the Lecythidean Myrtles a marked advance in sterility has occurred, and may still be in progress. It has affected in particular the andrœcium which has been transformed progressively into massive and sterile tissue which is in part glandular and in part petaloid. The latter part is marked by pronounced cellular gigantism, the presence of which feature is in some way connected with stamen sterility. The climax of these modifications in the group is the almost complete perversion of the andrœcium. A basis of generic distinction for certain organisms hitherto in doubt is further offered by the study of the floral development.

Dr. H. S. HOLDEN.—*On the Structure of the Endodermis in Alettris farinosa.*

Alettris farinosa is a small liliaceous plant occurring in the United States of America. The endodermis of the root passes through transient primary and secondary phases and, in the tertiary condition, consists of extremely thick-walled cells. The available evidence suggests that the suberin lamella developed in the secondary phase does not present a completely impermeable barrier to the exchange of materials between the endodermal cells and those of the stele and cortex respectively.

AFTERNOON.

Visit to Weetwood Hall.

Saturday, September 3.

Excursion to Bolton Woods.

Sunday, September 4.

Excursion to Malham.

Monday, September 5.**Discussion on the Carpel.**

Miss E. R. SAUNDERS.—

In the hitherto generally accepted interpretation of the *Angiosperm gynæcium*, only one type of carpel is recognised. This is conceived as a leaf member, folded inwards so that it becomes united either along its own margins or with those of its neighbours, and capable of bearing on these sutures *from one to several* rows of ovules. This conception is based mainly on the gross anatomical appearances in the earliest stages of flower development and on the outward aspect of the mature ovary. Neither method of examination is sufficiently refined to furnish critical evidence. Furthermore, certain features in some ovaries can only be brought into line with this *monomorphic* view by distorting the facts. Exceptional cases in which the carpels take on a leafy character have also been cited in support, but here, too, it appears that the evidence has often been misinterpreted.

The monomorphic view entails the acceptance of many morphological inconsistencies and unfounded assumptions. Among these may be mentioned the *commissural* stigma, the solitary *terminal* carpel, *free-central* placentation, false partitions, *supernumerary* styles and stigmas. It offers no explanation of the *obdiplostemonous* condition, of the occurrence of *dimorphic* fruits, of *reversed* orientation in allied forms or of certain modes of fruit dehiscence. In innumerable cases it is at variance with the clear evidence afforded by the vascular system and the stigma form, which has been almost entirely ignored.

On the other hand, the conception of the carpels as *polymorphic* structures offers a satisfactory explanation of all the above features, and accounts besides for many minor anatomical characters which, on the monomorphic interpretation, appear to be without significance. On this view it is held that two main carpellary types have originated in the course of evolution, the *valve* (hollow) type which, so far as appears, *never bears more than a single row of ovules on each margin*, and the *consolidated* (solid and semi-solid) type in which *from one to several rows of ovules may be borne on either side of the midrib*. With this diversity in carpel form there very generally occurs a redistribution of the three carpellary functions (stigmatic, protective, reproductive). When two types of carpel are present in the ovary, one only, as a rule, is fertile. The stigmatic function may similarly be restricted to one or other type, or may be performed by both. This polymorphic condition is found to occur throughout the whole range of Dicotyledons and Monocotyledons.

Dr. H. HAMSHAW THOMAS.—

When a morphologist who has been mainly occupied with the Pteridophyta turns to study the carpel he will be struck with the great neglect of anatomical evidence. Prior to Miss Saunders's, the only general survey of the vascular supply of the carpel was that of Van Tieghem, and he was concerned mainly with the demonstration of the foliar nature of the carpel. He gave the Ranunculaceæ, the Leguminosæ and Epimedium as examples of plants having simple carpels of the primitive type, but in the light of recent work not one of these plants can be regarded as having carpels composed of simple infolded leaves with marginal ovules.

Most authors have cited the megasporophyll of *Cycas* as the type of structure from which the closed Angiosperm carpel was evolved. This view is based only on analogy. The ovary of *Caytonia* deserves as much, if not more, attention, even without postulating any direct relationship between the Caytoniales and the flowering

plants. Here the ovules were borne in two rows near the midrib of the structure. It is quite possible that the megasporophyll of *Caytonia* will supply the clue to the morphology of the carpel of *Aquilegia* and other forms of a similar structure.

Dr. A. B. RENDLE, F.R.S., Dr. T. W. WOODHEAD, Mr. J. PARKIN,
Dr. E. J. SALISBURY, Dr. D. H. SCOTT, F.R.S.; Prof. J. M. McLEAN
THOMPSON.

Dr. J. B. LOTSY.—*Demonstration* (during the above Discussion) of
*Natural Hybrids between Plants and between Human Races in New
Zealand and South Africa.*

Prof. F. O. BOWER, F.R.S.—*Evolutionary Changes in the Superficial Sorus.*

In certain ferns the sorus took a superficial position in Palæozoic time, e.g. *Oligocarpia* and *Ptychocarpus*. Living examples are seen in *Gleichenia*, *Alsophila*, *Woodsia* and *Matteuccia*. Originally the sori were all radial and simple. Transitions followed to the gradate and mixed types, and the origin of a basal indusium accompanied them; the result is seen in *Woodsia*, *Diacalpe* and *Peranema*. The further step to zygomorphy of the sorus in relation to the leaf-margin was taken by *Peranema*; this eventuated in the soral type of *Dryopteris*. The similarity of this to *Lindsaya* and *Nephrolepis* was of homoplastic origin; they are essentially marginal types of Dicksonioid origin.

Dryopterid derivatives are seen in *Polystichum* and *Polybotrya*. A particular interest attaches to the elongated sori of *Didymochlæna*, *Fadyenia* and *Mesochlæna*, for these give the clue to the origin of the sori of *Athyrium*, *Diplazium* and *Asplenium*, which may be held as Dryopteroid derivatives, their indusia representing the remnants of the basal indusium of the Dryopteroid type.

Matteuccia and *Onoclea* are also superficial types, of which the former may be still non-indusiate. By fusion of such naked sori in linear series the cœnosori of the *Blechnum* type originated, covered in by the leaf-margin. These also show the transition from the gradate to the mixed state, together with the innovation of a photosynthetic 'flange.' By convolution and interruption of the cœnosorus upon a widening leaf-surface, as seen in *Blechnum punctulatum* var. *Krebsii*, and in *Campiosorus sibirica*, the condition is arrived at of *Phyllitis scolopendrium* (the Hart's Tongue).

Asplenium and *Phyllitis (Scolopendrium)* have usually been classed together; but if these comparisons be valid their soral similarities are homoplastic. In particular the protective flaps would not be homogenetic but homoplastic. The indusium of *Asplenium* would represent part of the Dryopteroid indusium; it would, in fact, be of true indusial character by descent. But the so-called indusium of the Hart's Tongue would be by descent an isolated portion of the original margin of the leaf-blade, which already in *Blechnum* has assumed an 'indusoid' character.

Prof. T. JOHNSON.—*Irish Fossil Gymnosperms.* (Communicated in title only.)

While Ireland now possesses only two indigenous conifers—*Juniperus* and *Taxus*—it was in the early Tertiary relatively rich. Though a scientific survey of the timbers found in the bogs has never been made, *Pinus sylvestris* is not uncommon, and *P. montana* var. *Mughus* is recorded. The writer has had the opportunity of examining the fossil plants collected by Bailey, Gardner and others in Co. Antrim, and those found in the core of the bore at Washing Bay, Co. Tyrone, in 1916, carried out by the Board of Trade in the search for coal. The paper deals with *Gingko*, *Taxus*, *Podocarpus*, *Pinus*, *Sequoia*, *Cryptomeria*, *Cunninghamia*, *Cupressus*, *Libocedrus* and *Ephedra*.

The deposits are regarded as Oligocene, with connection with those of Mull in Scotland, the plants showing affinities with the flora of East Asia, Pacific North America and the Mediterranean region. *Cunninghamia*, now confined to East Asia, is the most interesting addition.

Mr. JOHN WALTON.—*A Review of the Present Position of Knowledge of Palæozoic Bryophyta, with Descriptions of some New Types.*

Mosses.—There are only two reliable records of fossil-mosses of Palæozoic age—*Muscites polytrichaceus*, Ren. and Zeill., and *Muscites Bertrandi*, Lignier. Both records are from the upper carboniferous of France. The former consists of small shoots with leaves in the form of an incrustation on shale. The habit and the size of the leaves are the only evidence that we have of its Bryophytic affinity. The latter consists of a petrification of a small axis bearing multicellular uniseriate hairs which have oblique cross walls. The centre of the axis is not preserved, and the hairs are attached to the outermost of two or three layers of thick walled cells. The obliquity of the cross walls is very strong evidence for considering them to be rhizoids and for regarding the fossil as a moss stem.

Liverworts.—In addition to the liverworts described from the upper and middle coal measures of this country (Walton, *Ann. Bot.*, vol. xxxix, 1925), another type has been discovered which has a well-defined vascular strand differentiated from the rest of the tissue of the thallus, which was flat and ribbon-like and branched dichotomously. Since we have only vegetative structures to deal with, we cannot draw any certain conclusions about the relation of these fossil liverworts to the main divisions of the living ones. It is of interest to note, however, that as regards thallus organisation they are but little behind the living ones. Of leafy forms there is one representative, *Hepaticites Kidstoni*, Walt., which has almost as sharp a differentiation into axis and leaves as those liverworts which are classed in the *Acrogynæ*. There are several thalloid species, *Hepaticites Langi*, *H. Willsi*, and *H. vascularis* (MS.). The first two have a simple parenchymatous dichotomously branched thallus, while the last has a vascular strand which forks with the forking of the thallus. *Hepaticites lobatus* has a lobed thallus with a slightly differentiated axial region.

There were present, therefore, in Palæozoic times, as at the present day, liverworts with (a) differentiation into axis and leaves, (b) thalloid form with lobed margin, (c) simple dichotomously branched thallus, (d) thalloid form with highly differentiated vascular strand.

Dr. G. W. SCARTH.—*The Regulation of Stomatal Behaviour.*

(i) A brief historical statement.

(ii) A summary of the principal findings already published by the writer regarding the relation of stomatal behaviour to the H-ion concentration of the guard cells—studied chiefly by mounting leaf sections in penetrating acid or alkali.

It was found that stomata open both in acid and alkali, and that in the latter there are various intercellular changes which duplicate those associated with normal opening in light. Evidence was also discovered that the pH in the guard cells influences their turgor partly through its effect on the 'swelling' capacity of a colloid in their sap.

(iii) A short account of recent experiments to determine by means of indicators the pH of guard cells, &c., both in sections and entire leaves under various environmental conditions, pointing to the conclusion that the pH and turgidity of the guard cells varies readily with the CO₂ concentration of the leaf as a whole—regulated normally by its photosynthetic *v.* its respiratory activity.

Dr. HAROLD WAGER, F.R.S.—*The Effect of Light on Chlorophyll.*

Dr. F. W. WENT.—*Growth-promoting Substances and the Explanation of Phototropism.*

Small blocks of agar, gelatine and silicate jelly, placed eccentrically upon the cut surface of the coleoptile-stump of *Avena*, fail to induce curvature of the stump for the first two hours. However, if the gel had been in contact with the freshly cut surface of a coleoptile-top (in order to allow the growth-promoting substances to diffuse into the gel), then the stumps will show a curvature such that the block is situated on the convex side. It is possible to prove that the rate of curvature is determined by the concentration of the growth-promoting substances. These substances appear to be a limiting factor for growth (in the sense of Blackman) up to a certain concentration, above which concentration another limiting factor rather suddenly comes into play. The latter factor I assume to be the amount of material used in the cell-extension,

the concentration of which increases from the base towards the top of the coleoptile. This gives a plausible explanation for the specific distribution of the growth-rate over the coleoptile.

Experiments by Dolk (as yet unpublished) show that the absence of growth-promoting substances in the coleoptile of *Avena* causes an almost absolute stagnation in its growth. It follows, therefore, that any curvature must be caused by a one-sided increase or decrease of the growth-promoting substances. From this point of view I have analysed the problem of phototropic curvature; the results already obtained are in good agreement with the above assumptions.

Dr. W. H. PEARSALL.—*Metabolic Effects of Nitrogen.*

Dr. JAMES EWING and Miss E. ROUGHTON.—*The Influence of Hydrogen-ion Concentration on the Swelling of Plant Tissues.*

It has been found by several observers that plant protoplasm in its physico-chemical reactions resembles protein in showing marked amphoteric properties. In some respects plant tissues behave in similar fashion. The differential swelling which potato or beet tissue exhibits when placed in buffered solutions over a range of hydrogen-ion concentration from pH_2 to pH_7 , cannot be wholly explained by osmotic phenomena. While a large part of the swelling is undoubtedly due to osmosis, it is considered that the differences in water absorption at different pH value may be due, either to differences in hydration of the protoplasm or constituent proteins, or to some changed condition in the permeability of the cell membrane.

Tuesday, September 6.

Joint Discussion with Section A (Cosmical Physics Department) and Section C on *The Climates of the Past.*

Prof. A. C. SEWARD, F.R.S.—

Few problems make so strong an appeal to the imagination as those relating to climatic retrospects. It is important, in the first place, to state the nature of the evidence bearing on the problem; to consider whether or not the evidence is such as to bear the conclusions drawn from it. Fossil plants from different geological formations are compared with recent genera or species; it is generally assumed that the conditions under which the existing plants grow may be accepted as criteria of climatic conditions in the past. As examples of fossil floras, which appear to afford evidence of much higher temperatures in Arctic regions than at present, the following are selected for brief description: Upper Devonian; Rhætic; Cretaceous.

It is suggested that too little account has been taken of (I) the fact that closely allied plants have different reactions to climate, or of (II) the possibility of specifically identical plants becoming modified in their power of resistance during lapse of time as senility replaces juvenile vigour. In this connection reference may be made to recent work by Fernald on the persistence of plants in the Gaspé Peninsula during the last glacial period. There is the further consideration, that certain genera (*e.g. Gleichenia*), now mainly tropical in their distribution, are represented by some species which flourish at high altitudes where conditions are much less genial.

In the second place, having formed an estimate of the climatic contrasts between the past and the present, our aim is to discover the most probable explanation of these differences. Does the Wegener hypothesis offer a satisfactory solution? Can we, by altering the distribution of land and water, so far as is consistent with geological data, with its concomitant effects on oceanic and atmospheric circulation, reproduce temperatures believed to be required on palaeobotanical grounds, without having recourse to Wegener's floating continents and shifting poles?

Dr. G. C. SIMPSON, F.R.S., Mr. C. E. P. BROOKS, Dr. D. H. SCOTT, F.R.S.,
Prof. J. W. GREGORY, F.R.S., Dr. H. HAMSHAW THOMAS, Mr. J.
WALTON, Mr. R. J. MATTHEWS, Mr. R. D'O. GOOD.

Dr. ADRIANCE S. FOSTER.—*Nodal Anatomy and the Morphology of Bud-scales in Dicotyledons.*

One might be led to believe, from the confident opinions expressed in many botanical texts, that the morphological nature of bud-scales had been definitely settled, and hence no longer constituted a problem demanding further investigation. However, a careful survey made by the writer of the extensive literature on the subject, especially of the contributions of German and French investigators, indicated that sufficient differences of opinion have prevailed in the past, and indeed still exist, to warrant a complete re-examination of the problem with particular regard to the hitherto neglected evidence furnished by nodal anatomy.

The results and general conclusions drawn from the writer's investigation of the nodal anatomy of the bud-scales of about 130 species of ligneous Dicotyledons may be briefly summarised as follows:—

(1) Nodal anatomy furnishes an important clue to the specific homologies of bud-scales, especially in plants where these organs have been regarded equivalent to modified stipules or to 'fused' leaves.

(2) In the majority of the species investigated, the nodal anatomy of the bud-scales and foliage-leaves is identical.

(3) With few exceptions, the stele of the axillary bud of the scale or leaf is associated with the gap of the median trace, a fact of great assistance in the interpretation of specialised nodal conditions in the bud.

(4) Two types of nodal specialisation have been found, viz.:—

(a) The *reduced* node (confined to tri- and multi-lacunar species), where the scale receives fewer traces than the foliage leaf. Reduction involves either the suppression of one or more of the lateral traces, or, in stipulate leaved species, the suppression of the median trace with the development of the laterals.

(b) The *amplified* node (found in uni-, tri- and multi-lacunar species), where the scale receives more traces than the foliage-leaf through the addition of *accessory lateral* traces.¹

(5) The *reduced node* is frequently (not always) associated with the small outer scales of the bud, while the node of the inner scales usually simulates that of the leaf. The *amplified node* is often found in buds with a small number of well-developed scales, and seems to represent a higher degree of specialisation than the *reduced node*. A study of the comparative ontogeny of scales and leaves may be expected to shed light on the significance of these types of nodal specialisations.

(6) The close parallelism between the node of the bud-scale and foliage-leaf lends no support to the theories that scales are (a) organs *sui generis*, (b) vestiges of the primitive foliar organs of the Angiosperms, or (c) developmental possibilities of 'indifferent leaf-primordia.' On the contrary, the evidence from nodal anatomy, together with corroborative data from ontogeny, experiment, histology, transitional forms and teratology suggest that bud-scales probably represent *the original ontogenetic modifications of foliage-leaf primordia with subsequent evolutionary specialisation.*

(7) The fact that the nodal typography of the scale and leaf tends to be identical in a given species is evidence of the similarity in the early developmental stages of these organs, and emphasises the necessity for a *specific*, rather than a *generalised*, interpretation of the particular homologies of bud-scales.

Mr. A. E. S. McINTOSH.—*Perithecial Development in Nectria Mammoidea.*

The origin of the perithecium cannot be traced to any differentiated archicarp. The perithecium is at first composed of a small knot of twisted hyphae, all of which stain similarly. Later certain cells near the centre become differentiated and stain more deeply, while others disintegrate. This results in the formation of a cavity into which the differentiated cells protrude whip-like extensions. The central cavity enlarges and there arises a differentiation of the deeply staining central cells into an upper and lower group. The cells of the upper group by growth down into the cavity, ultimately reach the foot and intertwine with those of the basal group; these former

¹ Cf. Sinnott, E. W., 'Investigations on the Phylogeny of the Angiosperms,' I. 'The Anatomy of the Node as an aid in the classification of Angiosperms.'—*Amer. Jour. Bot.*, I., 303-322, 1914.

constitute the paraphyses. The lower whip-like cells are at first uninucleate, but on further development become multinucleate. These are the ascogonia, and occupy the lower half of the central cavity under the descending curtain of paraphyses. Each of these ascogonia gives rise to one or more hyphæ. Nuclei pass into these hyphæ from the ascogonia, increase by division, and then associate in pairs while the hyphæ become multicellular by septation. The tips then bend over in preparation for ascus formation. This is the highest developmental point of the ascogonia and the hyphæ produced by them. They disintegrate just as the paraphyses curtain closes down on them from above. The true ascogenous hyphæ arise directly from the vegetative cells at the foot of the cavity. These hyphæ consist of a single cell which is generally binucleate. Fusion takes place between two nuclei to give the definite ascus nucleus, and this nucleus divides three times to give the eight nuclei around which the spores form. The spore nucleus again divides and the spore becomes uniseptate. Meiosis takes place during the first two divisions in the ascus, the third being an ordinary vegetative mitosis.

Prof. Dame H. C. I. GWYNNE-VAUGHAN and Mrs. H. S. WILLIAMSON.—
Germination of Fungal Spores.

Considerable difficulty was experienced in germinating the ascospores of *Lachnea cretea* (Cooke), Phil., and development was first obtained after exposure to bright sunlight. Further experiment showed that the spores are not ripe for germination at ordinary temperatures till eight weeks after they leave the ascus. In younger spores germination can be induced by exposure to heat, the highest temperature and longest exposure being needed for spores newly shed. Ascospores remain viable for four years; conidia die more quickly, but are capable of germination as soon as produced. They are not killed by freezing.

Mr. B. BARNES.—*On Cultural Varieties of Fungi, produced by heating the Spores.*

Spores of *Eurotium herbariorum* derived from a stock which has remained constant in ordinary culture since 1922 have been exposed to high temperatures for a short time before sowing, and have then given rise to a number of variants, differing from normal cultures in colour and in form. Some of the variants have retained their peculiar characters through a number of transfers; others have shown a tendency to revert to the original form; some have died out.

Evidence has been obtained that the pigmentation of the sclerotia of *Botrytis cinerea* may be influenced by similar treatment.

These results have a possible bearing on the phenomenon of saltation in fungi.

Mr. JAMES STIRLING.—*The Occurrence of Monascus on Desiccated Coco-nut.*

The occurrence of this fungus on desiccated coco-nut is noted and its morphological features described. The development of the ascocarp has been followed chiefly in culture in glucose solution, but also in cultures on agar media. The presence of a fusion tube between the antheridium and the trichogyne of the oogonium has been noted, and nuclei have been observed in this tube midway between the two cells. Owing to the minute size of the nuclei and the large number present in the oogonial cell it is impossible to say whether or not fusion of nuclei takes place. Investment by hyphæ follows immediately on the passage of the contents of the antheridium into the oogonium, while at the same time the oogonial cell swells and becomes more or less spherical. Short hyphal protrusions, with aggregations of nuclei in their neighbourhood, are found round the periphery of this cell, and these give rise to the asci. The asci become spherical, growing at the expense of the central cell, which is crushed. The investing hyphæ are at first swollen, and do not completely envelope, but as development proceeds they become flattened and form a thin pellicle round the asci.

Dr. T. WHITEHEAD.—*Phlœm Necrosis and Starch Accumulation in Potato Leaf-roll.*

The phlœm of healthy and leaf-roll material of twenty varieties has been examined, and necrosis found to occur in all diseased specimens and not in healthy ones.

Necrosis was found in stem, petiole and the main veins of the leaf-blade, but not in the finer vein endings. It may consist merely of a swelling of the middle lamella, which eventually more or less obliterates the lumen, or may be followed by the deposition of ligno-celluloses. In many cases the radial walls of the phloem are much elongated.

Phloem necrosis, except in the most extreme cases of leaf-roll, does not occur to a sufficient extent to account for the excess accumulation of starch in the leaves, nor for the external symptoms of the disease; it is, however, possible that necrosis marks the end point of phloem disease and not its inception. Necrosis was not observed in plants affected with 'blackleg' or mechanical 'wilt.'

Starch accumulation in leaf-roll leaves is a reliable method of diagnosis in cases where the external symptoms of leaf-roll are somewhat doubtful, providing that whole leaves are used and that other diseases, which also induce excess accumulation of starch, are known to be absent.

Excess starch accumulation begins prior to rolling of the leaves, but pathological changes of the phloem may occur concurrently. By excluding light for six days, leaf-roll plants have been partially depleted of starch, but in a manner quite different from depletion in healthy plants.

A rough comparison of sugar and starch contents of healthy and leaf-roll leaves has been made at bi-hourly intervals during the night. At midday healthy leaves, which were full of starch, contained little or no reducing sugars. Conversion into such sugars began in the late afternoon, and by 5 a.m. the whole of the starch had been depleted. On the other hand, the leaf-roll leaves contained not only more starch at midday than the healthy ones, but also very much more reducing sugar. Translocation was very slow in diseased plants during the night, and the reserve starch was apparently not drawn upon at all.

MISS MARGARET MARTIN.—*The Influence of Ultra-Violet Light on the Structure of Plants.*

Observations have been made on the growth and structure of plants irradiated with a Hewittic 'Ulviarc' quartz mercury vapour lamp for short periods daily, as described by Miss Westbrook in a previous communication.

Plants of *Arachis* and *Voandzeia* showed definitely harmful effects when irradiated with the unscreened lamp for daily periods of 10, 5, 2 minutes and 1 minute respectively at a distance of three feet, over a period of five weeks. Some of these effects are described, and the reaction to such doses is followed at different stages in these and other plants.

When the daily period of irradiation was reduced to 30 seconds at a distance of 5 or 8 feet, there were indications of a stimulating effect upon plants of *Trifolium* and *Pelargonium*.

Voandzeia, *Pelargonium* and other plants have also been irradiated with the same light filtered through various screens, and the effects of isolated regions of the spectrum have been investigated in this way. The results are discussed in connection with the difficulties of obtaining screened light of comparable intensity.

MISS ALISON WESTBROOK.—*The Influence of Ultra-Violet Radiation on the Growth of Plants.*

Recent physiological research and medical experience have shown repeatedly the value of artificial ultra-violet light in remedial treatment and in maintenance of health. Much less is known of its action on plants, but stunting and other harmful effects have been reported.

Observations have now been made on the growth of plants as influenced by irradiation varying from $\frac{1}{2}$ minute to 15 minutes daily with a Hewittic 'Ulviarc' quartz mercury vapour lamp, the spectrum of which shows lines in the ultra-violet from $\mu\mu 226-400$, together with intense bands in the violet, blue, green and yellow. Distances were chosen such as to avoid local heating at the surface of the plant. In other experiments various screens have also been employed, transmitting only certain parts of the spectrum:—

1. *Clear Vitaglass*: transmitting 90 per cent. of the visible rays and a proportion of ultra-violet rays of 20-30 per cent. in the region of $\mu\mu 290$.
2. *Blue Uviol*: transmitting the blue-violet and ultra-violet rays to about $\mu\mu 290$

3. *Chance's Ultra-violet Glass* : transmitting a little of the violet and ultra-violet rays to at least $\mu\mu 300$, mainly $\mu\mu 3300-3900$.

Various methods have been employed in order to determine the equivalent exposures under these screens. The difficulty of obtaining light of comparable intensity in each case is discussed.

Mr. F. T. BROOKS.—Lecture on *Disease Resistance in Plants*.

Wednesday, September 7.

Prof. F. E. FRITSCH.—*The Genus Sphaeroplea*.

Sphaeroplea has usually been regarded as a septate member of Siphonales of uncertain affinities. Apart from the multinucleate character of its 'cells,' there is, however, nothing in favour of such a relationship. A survey of the features presented by the different species (well represented in South Africa) indicates an affinity with Ulotrichales, on the grounds both of vegetative and reproductive characteristics.

Dr. HAROLD WAGER, F.R.S.—*The White Strip on the Leaf of Crocus*.

Mr. C. V. B. MARQUAND.—*Arctic Alpine Bryophyte Associations in Britain, as compared with those of Western and Central European Mountains*.

Mr. H. DUERDEN.—*The Sporangia of Selaginella*.

In heterophyllous species of *Selaginella* the megasporangia tend to occur in line with the large ventral leaves.

In many cases the number of megaspores in the sporangium is increased. In *Selaginella Watsoni* one case of eight megaspores; *Selaginella Lobbii* eight, twelve, fourteen, sixteen, eighteen and twenty. In *Selaginella Willdenowii* sixteen, thirty-six and forty-two megaspores.

Mr. T. M. HARRIS.—*The Fossil Plants of N.E. Greenland*.

SUB-SECTION K*.—FORESTRY.

Thursday, September 1.

Prof. FRASER STORY.—*World's Timber Supply and Consumption*.

The timber supply problem concerns soft woods principally because, to the extent of over 80 per cent., the world's demands are for timber of this description. The conifers which produce soft woods are found extensively only in temperate regions and are practically confined to North America, Northern Europe and Siberia.

In the United States one district after another has been cut over until nearly all the lumbering activity is centred in the few Western States, the resources of which at the present rate of cutting cannot be expected to hold out for more than twenty to thirty years. Forest exploitation in Canada has followed a remarkably similar course. The once heavily timbered regions of Eastern Canada have been cleared of practically all large-sized timber and the soft woods of smaller dimensions are now seriously threatened owing to the great demands made on them by the paper-pulp industry. According to official statistics, three-quarters of Canada's merchantable timber has already been destroyed or utilised.

Apart from North America, approximately 75 per cent. of the world's soft-wood area is located in Northern Europe and Siberia. In Europe the consumption of soft woods exceeds growth by about 3,000 million cubic feet. Most of the existing coniferous forests are to be found in Northern Russia, but this area cannot be relied upon owing to its inaccessibility and the sparsity of the population. For similar reasons Siberia, although containing vast forests, cannot be economically exploited.

Possibly, as resources diminish, greater care will be exercised in forest protection and timber utilisation. Even so, however, a serious shortage of soft woods is in sight with an accompanying marked rise in prices. Great Britain will be one of the first to suffer because it imports more soft woods than any other country and obtains 90 per cent. of these supplies outside of the Empire.

Mr. R. S. PEARSON.—*Utilisation of Soft Woods, Developments and Improved Methods.*

The paper opens with a paragraph explaining that the subject is a very large one which can be discussed from several viewpoints, and that one of the most important factors governing the situation is the present position held in the market by softwoods of foreign origin. It goes on to discuss the reason why home-grown softwoods are not favoured by architects and builders, citing the primary causes, such as the quality of the timber, the scattered nature of the forests, their individual limited area, and the consequent difficulty in obtaining large supplies of uniform grades.

The position of the import trade is then discussed, and the economic position reviewed with reference to the source of supply and the large quantities available, permitting of grading and a study of market requirements.

The paper goes on to point out that the problem resolves itself into the question of creating large forest areas in this country, and in co-ordinating existing supplies on the one hand and of improving methods of utilisation and in determining what species to plant on the other. The former problem being outside the scope of the paper is not further discussed, and the question of more intense utilisation and what species to plant alone dealt with.

A review follows as to what has been done to solve similar problems in other countries, followed by a more complete analysis of the functions of a Forest Products Research Laboratory in investigating the anatomical structures of wood, its strength factors, seasoning and working qualities, durability, possible uses and its deterioration from fungi and insects.

The paper concludes by giving three definite examples of these classes of investigation, and ends with a plea for discussion.

Mr. WM. DALLIMORE.—*Minor Forest Products.*

This paper directs attention to many of the minor products of forests that occur in various parts of the world. Some of them help very materially towards the financial success of silvicultural undertakings, and they should receive greater attention from forest officers in general. The aim of the writer is not to present an exhaustive treatise upon the subject, but to bring forward suggestions for discussion in order that a better understanding may be arrived at as to the future possibilities of these products. Among the subjects mentioned are oils, resins, tans, dyes, drugs, maple sugar, nuts, &c.

Mr. G. K. FRASER.—*Wood Derivatives.*

Mr. W. R. DAY.—*Forest Mycology.*

There are three chief branches to forest mycology: first, the study of the pathology of trees as related to plant parasites; second, the nutrition of trees as dependent on the soil micro-flora; third, the decay of sawn timber.

Forest pathology is to-day dominantly the pathology of conifers. For an understanding of the present position in forest pathology, there must be a true appreciation of the way in which Britain is becoming reafforested, chiefly with species that are not only exotic but are also of an entirely different type from those indigenous and to which the soils reafforested are not immediately suited or adapted even if the climate is more or less agreeable. This situation is complicated by an incomplete understanding of the requirements of the new species and the introduction with them of exotic parasites of yet largely unknown importance. The pathology of broad-leaved trees is here shortly compared with that of conifers.

Closely related to pathology is the study of the relation of fertility to the micro-flora of the forest soil. It is probably more important when reafforesting a difficult soil to establish a suitable soil micro-flora than to attempt, in the first instance, the growing of an economic crop.

The key to future progress in the prevention of timber decay is, first of all, an appreciation of the preventable economic loss endured in this way and then a wider knowledge among timber users of the rules necessary to limit or prevent the growth of the fungi causing it. This is a matter in which co-operation between the economist and mycologist will bring the most fruitful results.

It may be said generally that there is, at the present time, far too little study of the biologic relationship between the fungus and its host or the substratum on which it grows. Upon the prosecution of this study all future progress depends.

Dr. J. W. MUNRO.—*Forest Entomology.*

Friday, September 2.

Dr. G. W. ROBINSON.—*Forest Soils.*

Mr. E. V. LAING.—*The Living Tree.*

The living tree attains its best development under a definite set of conditions—climatic, edaphic, and biotic—and to save labour and time and to eliminate trial and error methods in planting, a knowledge of the factors operating within the range of any particular species is called for. The question of the living tree and its growth factors is a complex one, but one factor may compensate for another, as, for instance, reduction of light intensity may compensate for poor soil conditions, and good soil may mitigate the effects of exposure and altitude. The limiting factor to a tree's growth may be some element such as nitrogen, potash or magnesia. Frequently the nitrogen exists in a form unsuitable or unavailable to the tree, and in such conditions the presence of a suitable fungus to form Mycorrhiza may become of vital importance. The whole question of the growth factor leads to that of the health of the tree. When the habit and habitat of each species are known, a safe guide is provided regarding the soil and locality best suited for its successful cultivation as a forest crop.

Mr. W. H. GUILLEBAUD.—*Sylvicultural Surveys.*

Saturday, September 3.

Dr. T. F. CHIPP.—*Forestry in Relation to Climate and Erosion.*

The influence of climate on forests is generally recognised; some examples of this aspect are given with references to recent work. Considerable controversy has arisen with regard to any influence forests may have on climate. Many publications on the subject cite evidence from hydrology, 'exsiccation,' or topographic or biotic factors. An examination of the principal climatic factors shows that the presence of a forest mass exerts an influence in its immediate vicinity. The forester's conception of climate is not necessarily that of the climatologist, and it is a matter for consideration whether the forester cannot ascertain the effect of forest better by the aid of phytometers than by the data furnished by meteorological instruments.

Mr. C. E. P. BROOKS.—*The Influence of Forests on Rainfall.*

The possible influence of forests may be general, *i.e.* on the rainfall of the whole district, or local, *i.e.* confined to the actual forested areas. The general influence should depend on the relative amounts of water vapour passed to the air by forests, crop land and bare soil. Three processes are effective, evaporation of rainfall intercepted by foliage, evaporation from soil, and transpiration. The available data suggest that the total is greatest from crop land, least from bare soil. Hence, the replacement of forests by crop land should increase the general rainfall slightly, replacement by bare soil should decrease it. Owing to the variability of rainfall from other causes, it is difficult to find actual examples of these effects.

In dealing with local rainfall, it is necessary to distinguish between the *catch* of rain and the true fall. The excess of rain generally shown by forest clearings over open sites is mainly due to the shelter of the gauges from wind eddies. The true fall

over forests is found to average only one or two per cent. above that in the open; this is due to the increase in the effective height of the ground caused by the forests. Forests are beneficial in conserving the winter snowfall.

Dr. A. W. BORTHWICK.—*Forestry in Relation to Water Catchment Areas.*

AFTERNOON.

Excursion to Fewston Reservoir of Leeds Corporation.

Sunday, September 4.

Excursion to Jervaulx Abbey Woods.

Monday, September 5.

Address by Sir PETER CLUTTERBUCK on *Forestry and the Empire.*

Opening with general remarks on the importance of forests to mankind, the coming timber famine is referred to. This pending calamity has resulted in a revival of interest in forestry in many parts of the Empire. With a view to stimulating sound principles, a system of periodical Empire Forestry Conferences was inaugurated in 1920 in Great Britain, was continued in Canada in 1923, and is to be continued in Australia and New Zealand in 1928, and in South Africa in 1933. Lord Lovat, then Chairman of the Forestry Commission, was the prime mover in this matter. About the same time the Empire Forestry Association was started under Royal Charter, with a view to fostering interest in forestry and to assist in every possible way in developing and encouraging correct principles of forest management.

In order to provide for the future a judicious conservation of existing forests is necessary, while afforestation would have to be undertaken in countries not possessing a sufficient forest area. Timber, resulting from such efforts, will not, however, in most cases grow quickly enough to affect the threatened famine. Every device for mitigating this famine must be sought for and pushed. Such devices are by economising the consumption of soft woods, by persuading consumers wherever possible to use the lighter hard woods available from the more tropical parts of the Empire instead of soft woods, and by fostering the use of materials other than wood for the manufacture of paper-pulp, and thus help to eke out the supply of soft woods.

The forestry position in the various parts of the Empire is then touched upon.

Mr. R. L. ROBINSON.—*British Forest Policy.*

The paper is divided into three parts:—

(1) *Pre-war Policy*, indicating briefly the efforts made by the State to safeguard the supply of shipbuilding timber, for example, after the Civil Wars and the Napoleonic Wars; the period of neglect following on the decline of wooden ships and the free access to abundant supplies of overseas timber to meet the needs of the great industrial expansion; the revival of interest during the twenty years or so preceding the Great War.

(2) *Current Policy*.—The experience of the Great War; the Acland Committee's programme; the Forestry Act, 1919; the Forestry Commission: its constitution, procedure and results achieved; the probable position at the expiration of the Commission's tenth year of existence.

(3) *Future Policy*.—Factors bearing on its determination; the state of British woodlands as disclosed by Census of Woodlands; probable demands for timber; prospective supplies; productivity of and extent of land available for afforestation; forestry and land settlement; responsibility of the State; bases of action, finance and administration.

Mr. A. C. FORBES.—*The Maintenance of Permanent Soft-wood Supplies in North-Western Europe.*

The importance of an adequate supply of soft-wood timber is greatest in those countries in which industrial development is most advanced; building and railway

construction, paper-pulp and packing boxes representing the main purposes for which coniferous soft woods are used. With the exception of Germany and Italy, the industrial countries chiefly relying upon supplies of soft wood imported from Northern Europe are those lying along the north-western seaboard, including Belgium, Denmark, France, Holland, Great Britain and Ireland. These countries have the lowest area of forest per head of population, and would feel most acutely any serious shortage. Their annual imports are, according to Mr. Fraser Story, about 600,000,000 cubic feet, their total consumption nearly 12,000,000 cubic feet. This does not include pulpwood or hardwood. Great Britain takes nearly two-thirds of the total import. The normal increment from 7,500,000 acres of conifers, of which about 66 per cent. are privately owned, is about 300,000,000 cubic feet, so that there is an apparent over-felling or reduction of the capital stock equal to 25 per cent. of the total consumption.

Northern Europe possesses about 300,000,000 acres of coniferous forest capable of producing, under proper management, the whole of the industrial deficit elsewhere in Europe for all reasonable time. Sweden and Finland possess one-fourth of this area, and their forests are conservatively managed. Russia is at present an uncertain quantity. The present exports from Northern Europe of about 800 to 900 million cubic feet could not be greatly increased at present without over-felling.

The chief measures most likely to assure the maintenance of an adequate supply of soft woods are :—

(1) Better protection against fire and more intensive management of the existing forest area.

(2) The conversion of unprofitable hardwood areas into coniferous forest.

(3) The afforestation of land possessing a low agricultural value.

(4) The lowering of the *per capita* consumption of soft-wood timber by substitutes such as ferro-concrete, plywoods, and pulpwood from hardwood timber, &c.

The high percentage of privately owned forest in most parts of Europe suggests a more adequate control of all forest land by the State, leading to more intensive management and the prevention of over-felling. Afforestation of poor land is a State enterprise, and cannot be effected on an adequate scale without legislative measures. The discovery of substitutes for coniferous wood is a matter for research and investigation.

The possibility that population and industrial activity in Europe have reached their maxima, and that present estimates of future timber consumption may be excessive, must not be left out of account.

Dr. J. D. SUTHERLAND.—*The Economic Balance between Agriculture and Forestry.*

Intervention in land utilisation has been forced upon all Governments. The extent depends upon the natural resources of the country, their development, the system of tenure, and upon the recognition of national conservation as a policy. Such a policy implies that a certain balance is regarded as necessary.

In Great Britain the chief protagonists of the hinterlands are agriculture and forestry, with sport as guerillist.

In none of these spheres can the requirements of the country be fully produced, and inquiry is made as to how far the natural balance has been upset, and whether definite economic improvement could be obtained by redistribution.

In this connection the actual and potential contributions of the various classifications of land are considered with a view to determining whether retention in their present categories is nationally economic. The consumption and imports of the country in agricultural and forest produce are also compared, together with the relative costs.

State aid to agriculture has evidently not been ungenerous. The current year's appropriations amount to over £15,000,000 in Great Britain, and analysis of this is contrasted against expenditure upon forests.

The reactions and relationship of Agriculture and Forestry upon and with each other are of vital importance.

Mr. W. B. TURRILL.—*Forests of the Balkan Peninsula.*

Naturally most of the Balkan Peninsula should be forest clad, but owing to the destructive activities of man and his domesticated animals the lowland and hill

zones are now denuded of trees in many parts. The woody vegetation, floristically and ecologically, can be subdivided into three main types: Mediterranean, transitional and Central European, and all of these show very clear altitudinal zonation. Climatic factors are of greater importance than edaphic in limiting the distribution of the various communities. Within the Mediterranean domain the most important communities are those of *Pinus halepensis*, *P. pinca*, oaks, laurels, *Platanus orientalis*, *Cupressus sempervirens*, *Abies cephalonica*, *Taxus baccata*, beech, and *Pinus nigra*. In the transitional areas manna-ash, oak woods, the Strandja woods, limited communities of *Aesculus hippocastanum* and *Ostrya-Fagus orientalis* forest can be distinguished. Within the Central European domain the important forest communities are the oak woods, chestnut woods, *Pinus nigra* association, the *omorika* association, fir and spruce association, and beech association. The composition and successional stages of these are of considerable interest when compared with corresponding features in better-known parts of Europe. The causes of the replacement of forests by various types of brushwood-macchie, pseudomacchie, phrygana and shibljak and the final degeneration to poor grassland or stony ground with a meagre open vegetation are nearly all connected with man.

Tuesday, September 6.

Mr. WM. RAITT.—*Paper Pulp from Bamboo.*

Mr. S. K. MUKERJI.—*The Forests of Kashmir.*

This paper, illustrated by lantern slides, embodies the results of extensive ecological study of the Forest Communities of Kashmir up to an elevation of 14,000 feet. It deals with the geological, climatic, physiographic, edaphic, and biotic factors of the region.

Types of Forests:—

Winter Deciduous Forests: *Populus*, *Aesculus*, *Acers*, *Fraxinus*, *Ulmus*, and *Betula*.

Coniferous Forests: *Pinus excelsa*, *Cedrus Deodara*, *Cupressus torulosa*, *Taxus baccata*, *Picea morinda*, *Abies Pindrow* and *A. Webbiana*.

Undergrowth of forests and their ground flora. Succession of Forest Communities. Striking absence of 'Oak-belt' in Kashmir Himalayas. Limestone rocks in relation to occurrence of special types of Forest Communities. Natural Regeneration of some valuable timber trees. Brushwood of *Parrotia Jacquemontiana* in relation to Regeneration of Deodar and Blue-pine. Effect of grasses on seedling regeneration and afforestation. Exploitation of Forests in Kashmir. Preservation of Forests—'The Rakhs.' Some useful Forest produce of Kashmir.

Vast field for developing scientific farming of important indigenous medicinal and economic plants. Edible mushrooms and morellas.

Suitable field for extensive cultivation of species of *Populus* for wood-pulp.

SECTION L.—EDUCATION.

(For references to the publication elsewhere of communications entered in the following list of transactions, see p. 435.)

Thursday, September 1.

Joint Discussion with Section J on *Psychology of Special Scholastic Disabilities.*

Miss G. HUME, Miss WHEELER, Miss McALLISTER. (See p. 372.)

Overseas Training Committee. Paper by Commissioner D. C. LAMB on *Importance and Value to the Empire of the Transplantation of Boys, &c.* (See p. 309.)

Friday, September 2.

Discussion on *Education in Tropical Africa*. SIR THEODORE MORISON, MR. RIVERS SMITH, MR. NORMAN YOUNG, MAJOR A. G. CHURCH, MISS S. BURSTALL.

SIR THEODORE MORISON.—*An Educational Policy for Tropical Africa*.
(Read by Dr. KIMMINS in the unavoidable absence of the author.)

The official policy in regard to education in Tropical Africa now defined : it is to 'produce a better kind of African, not an inferior imitation of a European.' A sound policy, but a hard one to put into practice. Indian experience shows that English thought is very destructive of indigenous beliefs. In Nigeria, where a considerable proportion of the people are Moslem, it may be possible to avoid 'denationalisation' by drawing upon the rich stores of Islamic learning. In East Africa, where indigenous culture is slight, the task is much harder. The best hope lies in giving education in the vernacular. Do not teach in English at all, even in the University—if ever there is one. Set to work at once to make Swahili the cultural language of East Africa. Enrich it with translations ; hammer out a scientific terminology, form words and phrases to express abstract thought. The object is to make Swahili a fit vehicle for precise ideas. The Governments of East Africa must combine to set up a Translation Bureau, as has been done at the Osmania University of Hyderabad.

This is the most important item of educational policy in East Africa ; the second is to train the hand and eye and teach the simpler arts of rural life, viz. : ploughing, weaving, and the use of the potter's wheel. So direct both education and the administration that it may be clear to the African that his own personal advantage rather lies in developing the economic resources of his country than in becoming a lawyer or a clerk.

MR. RIVERS SMITH.—*The Education of the African Chief*.

The problem of the education of the African Chief is largely an administrative problem, and must be regarded in its special relation to his position as the leader of his people, and the change in that position which has come about as the result of the necessity to make tribal autocracy conform to ordered government under civilised rule.

The best results are to be looked for by the adaptation to the demands of civilised societies, of what can be retained of native social systems ; and so to-day we find a marked tendency to develop systems of indirect rule in which native authorities are encouraged, under the guidance of their European administrators, to accept a larger measure of responsibility for the maintenance of law and order in the tribal unit ; and eventually, through a natural process of evolution, rather than by an undue insistence on Western systems, to enable that unit to find its natural expression in the new social order which must grow as the result of impact with civilisation.

One of the finest characteristics of the pagan African, in addition to his well-developed communal sense, has been his loyalty to constituted authority as recognised in the person of his chief. The successful growth of a system of indirect rule would appear, therefore, to depend on the maintenance of the authority of the hereditary head of the people. The education of the heirs to this authority must therefore fit them to exercise that authority in accordance with the requirements of good government, while maintaining what is best of their own social systems and adapting them, where necessary, to the changed conditions.

The first duty of the school must be to exercise care not to destroy a good African by the inculcation of ideas and tastes which cannot find expression in an African community ; the aim should be to produce perhaps a new but finer conception of the African rather than a spurious imitation of the European.

The young chief will eventually have to exercise judicial functions, and at least those laws which native authorities are competent to administer should form a subject of study. An elementary knowledge of procedure and of the administrative system generally must be taught, and, above all, the pupil must be imbued with a sense of civilised justice. But more important even than his magisterial duties are his social

responsibilities. In the present stage of development he must in a very real sense be the civic leader of his people, and should possess therefore a working knowledge of the social services.

His training should be essentially a practical one, though his general education should be no less thorough than that given to other young men whose responsibilities are less. He should leave school well equipped as an agriculturalist and possessing a sound knowledge of animal husbandry; citizenship and hygiene are of prime importance; and some skill in handicrafts should be encouraged. Recreations and the wise employment of leisure are matters which need to be stressed while the future chief is at school.

Mr. NORMAN YOUNG.—*Problems and Personalities at the Accra Teachers Training College.*

The Training College a Government institution, founded in 1911 and now taken over by Achimota. It and the kindergarten the only departments of Achimota thus far open.

Rediscovery in West Africa of the important commonplace that 'educational problems' largely resolve themselves into the mystery of the personalities of Tom, Dick and Harry—known in our country as Pudjo, Pobbina and Kwami.

Consideration of a few outstanding College Characters.—Attempt to discover a common denominator. After one tour the search leads chiefly to a series of paradoxes. They are frank in feeling and circuitous in thought; self-confident in the adoption of other people's opinions, literal-minded and yet lovers of abstractions; having moral and religious aptitude, yet scant application.

Some Problems in the light of their Characteristics.—The job of the Training College threefold: to develop good scholars, which involves supplementing and correcting the training given in Standards I to VII; to teach them to teach; to train them to take the lead in developing a new West African culture.

Problems in the Making of a Scholar.—*E.g.* rule of thumb tradition in the schools in which they have been trained.

Problems in the Making of a Teacher.—*E.g.* their phenomenal memories, but reluctance to readjust methods to suit particular classes, &c.

Problems in Training them for Leadership.—*E.g.* they are too ready to adopt European ideas, and too slow to adapt them—considerable understanding often shown, but little originality.

Village patriotism strong and natural, but national and racial patriotism stilted and rather self-righteous.

Perhaps the greatest problem is the prevalent conception of education—you buy it as you buy automobiles—'a means of getting on faster.' Everyone wants education, for it appears to spell power.

Major A. G. CHURCH.—

The impact of the alien trader and missionary upon the natives of Africa results in the breakdown of tribal arts and crafts and native customs and social pleasures. This breakdown has been accelerated by the cessation of intertribal warfare consequent upon the introduction of a 'white' administrative system, the encouragement given to native cultivators to produce crops for export, and our interference with their system of shifting cultivation. Village life becomes dull for the ambitious and adventurous male. The flight from the land is the logical outcome of native discontent with his changed environment. Can this be arrested? The task confronting Europeans in Africa is to train natives for new functions they must perform under the changed conditions prevailing. Professional and semi-professional as well as industrial workers are needed. What type of education is necessary for these various classes? Will the problem of the industrial worker be solved by giving him a purely vocational training? What is to be the basis of the training for industry? Can industrial work be given a dignity comparable with that of professional work? A few tentative suggestions are offered in the paper.

Miss S. BURSTALL.—*The Education of the African Woman.*

Demand only just beginning in most of the nine colonies. Coast areas in West Africa, special conditions. Simplicity and difficulty of the problem. The primitive

African woman: her duties in the social organisation. The four H's: Hygiene, Housecraft, Handwork, Horticulture. Infant mortality. Food and gardens. Application of the general principles of the White Paper, March 1925 (Cmd. 2374). Religion. The missionaries must do most of the work. No demand in Islamic areas. The Girl Guide movement. Solution of the problem in a School Village in Northern Rhodesia, by Miss Mabel Shaw (London Missionary Society). Native girls live in their own way, sleep in huts, grow food, &c. Approval by parents, eager to pay fees: bride price above average: girls stay till 17 or 18. Boarding school essential. Tanganyika, U.M.C.A. plan. Recreative subjects: music, dancing. How far should girls learn English? Cf. French in the education of an English girl, or Latin in the Dark Ages of Western Europe.

The African girl in Europeanized families: the West Coast problem. How not to do it. The new Queen's College at Lagos. Demand from Uganda. Difficulty of securing African women teachers, especially for villages. Jeanes School in Kenya. The married woman teacher essential: cf. French methods in their African Colonies. The European married woman in Africa, especially in the official class. Local Boards of Education. Need for good English mistresses, Government or mission. Better education of the European child in Tropical Africa, especially the girls in Kenya. Northern Rhodesia, girls' schools needed.

The text-book problem: vernaculars: the influence of the mother in the home. French text-books. The new International Institute of African Languages and Cultures: standardization and verification of dialects. A great task for to-day: a great hope for the future.

Sir JOHN RUSSELL, F.R.S.—*Report of the Overseas Training Committee.*
(See p. 309.)

Presidential Address by Her Grace the DUCHESS OF ATHOLL, on *The Broadening of the Outlook in Education.* (See p. 191.)

Monday, September 5.

Discussion on *Education and Industry.* Mr. J. WICKHAM MURRAY, Mr. E. WALLS, Mr. J. H. EVERETT, Dr. H. SCHOFIELD, Mr. A. P. M. FLEMING.

Mr. J. WICKHAM MURRAY.—*New Outlooks and Tendencies.*

Preliminary.—It is to be noted that the views expressed in this paper are not necessarily those of the executive or central committees of the Emmott Committee of Inquiry into the Relationship of Technical Education to other Forms of Education and to Industry. Further, the view taken throughout is that in Technical Education is to be found the best link between education and industry. Reasons for this view.

How does Industry regard Technical Education?—Is there any evidence to show that industry recognises the help it receives from education, values that help and desires to contribute help and advice towards reshaping the education system? Can any broad lines of advance, with which industry is in agreement, be set down? The views of industry upon (a) the grouping of educational facilities; (b) content of curricula; (c) supply of staff; (d) research; (e) training of artisan, foreman, manager.

How does Education regard Industry?—Machinery which has been used hitherto, e.g. advisory boards of employers, employers on local education authorities, &c. Informal nature of interest hitherto taken in the possibilities of education as an essential to industry. Sandwich systems. In some cases educationists tend to fear that the influence of the industrialist may take something away from what is regarded as the 'liberal' quality of education; is this a real danger?

Changing Philosophies in Education.—Tendencies which may be observed (a) in the attitude of the Board of Education; (b) in the recently expressed views of teaching bodies; (c) in the reports of committees such as the Malcolm Committee on Education and Industry; (d) the Balfour Committee. The Junior Technical School.

Humanistic Aspects of Technical Education.—Difference between vocational instruction and technical education; the cultural possibilities of the latter. Educational administration should secure unity. Difficulty and necessity of labels such as

'Primary,' 'Secondary,' 'Technical,' 'University.' The present position. Social balance between craftsman and clerk. The dual problem of the 'black-coated' worker and the lack of skilled craftsmen. Dependence of technical education on primary and secondary education. Adult education. Relationships with the universities. Training of teachers for technical education.

Some Suggestions.—Development of the local college. Matriculation conditions. The kind of local and national machinery which might produce definite relationships between education and industry. Advanced classes. Development of day classes. Transfer of pupils in secondary, junior technical and central schools.

Mr. E. WALLS.—*Educational Needs of Industry.*

There is needed a greater co-operation between the schoolmaster and the employer. The ultimate active life of 90 per cent. of the pupils is in industry, and educational plans should have the working life of the pupil in mind from start to finish. This does not mean that education has to be utilitarian. There is needed more grading, by observation rather than by examination, a constant sieving, which almost automatically brings the pupil to his most likely destination in life. In this way the school is the true junior employment bureau. An attempt to place scientific and literary studies in the true relation. The bearing of educational methods on industrial peace.

Mr. J. H. EVERETT.—*The Technical Colleges, their Courses and Problems.*

Aims.

To supply the requirements of industry. To train young persons for their work in life. Not necessarily to give skill, but rather to teach, by practical methods, the principles of the trade in which the apprentice is employed. To give adaptability so that the apprentice can become a fully competent worker or craftsman.

To keep up, and where possible to improve, the standard of the ordinary workman; but also to train selected men for executive or managerial positions. Must be 'education' and not merely 'instruction'; technical education can have some 'cultural' value.

Courses.

In order to meet requirements, courses are either full-time or part-time.

Full-time courses are for those who want good preparation before entering industry, or for those who can make it possible to leave industry for a period in order to undergo special training, which implies that they should be able to return to industry.

Part-time courses are for those who remain in industry and take courses of study concurrently. This work is much better done in the day-time when the mind is (or should be) clearer and more responsive.

Full-time courses are conducted in junior technical, art or commercial schools, and also in senior technical schools and colleges. The junior courses are of a general character, the only bias being towards industry as a whole; the senior courses are arranged to meet the needs of separate industries.

Part-time courses affect by far the larger number of students and present special problems. Such courses usually entail an attendance of three evenings a week over several winter sessions, although where employers are favourably disposed, and trade organisation will allow, apprentices attend one or two half-days in lieu of certain evenings; in such cases the day attendance may continue through the summer term.

The courses are usually graded as junior (two years), senior (two, three or four years), and advanced (one, two or three years). The courses are arranged on the 'group course' system; its educational advantages; difficulties with the allied (or ancillary) subjects.

Three evenings a week, with homework in addition, appears to be too much for at least some students. Is it advisable to institute two evenings a week group courses? Danger of the soft option. Other solution is day attendance.

Major and minor courses with possibility of transfer from one to the other.

All courses involve or should involve practical instruction in some form or other, ranging from the academic type to the craft or trade type. Equipment problems.

All courses should include costings and organisation in the later or advanced stages, but for general information rather than from the professional accountancy standpoint.

Examinations and Certificates.

Object of examinations and value of certificates. Multiplicity and need for co-ordination.

Some problems and difficulties.

The whole system voluntary. Great variation in attainment, ability and needs of students. Overtime and the shift system. Gap from fourteen to sixteen and the summer gap. The teacher, full-time and part-time. Annual leakage of students. Small advanced classes.

Have technical schools the whole-hearted support of Industry? Need for local and national advisory committees. Preparation for trade revival.

Dr. H. SCHOFIELD.—*Engineering Training on Production.*

Although the subject of training the engineer is one full of controversy which does not apparently grow any less as experience proceeds, there is yet one point upon which we have almost complete unanimity, namely, that somewhere in the training of the engineer must come time spent in actual practical experience on productive output. This may precede or follow a University or Higher Technical College training, according to the views held by those responsible for placing students in such institutions. There are difficulties whichever way the course is taken, and it was in an endeavour to get over these difficulties that the scheme of training now in progress at Loughborough College was founded.

Whether we approve or not, in general, the system of Engineering production in this country is tending to change. The mass system of output is slowly but surely gaining ground, and must extend if we are successfully to meet the difficulties of world-wide competition. Consequent upon this system it may be shown that the best boy tends to have the least chance. The mobility allowed to the average young man in our modern works is small, and there is little connection between the manufacturing and the distributing sides.

If we turn to the institutions responsible for the theoretical side of a student's training, we find other difficulties inherent in the system. There is a tendency which will grow alarming, unless carefully checked, for the College or University responsible for technological training to become dissociated from the industry for which it is responsible for training recruits. Many reasons may be given for this, not the least of which is the practical difficulty of teachers keeping in organic contact with industry on its commercial side. University Courses in Engineering and allied Technology are designed, perhaps of necessity, on a mathematical and physical basis, yet for an all-round engineer there are three aspects of training, each of which is equally important:—

1. Its Mathematical and Physical side.
2. The question of Management.
3. The art of Selling, Distributing, and obtaining a Market.

The so-called engineering workshops in our larger technical institutions tend to become laboratories rather than workshops in the real sense of the term.

Various methods of training have been introduced from time to time to deal with the above difficulties; the Faraday House system embodies a very good admixture of the theoretical and the commercially practical; the works productive 'bays' in large firms such as the British Thomson-Houston Company, Limited, of Rugby, and Messrs. W. H. Allen & Company, of Bedford, give an excellent method of keeping the student in touch with production during his years of training; the experiments in America, at Worcester and Cincinnati, should also be quoted as giving a successful method of tackling this problem.

In the productive college the exercise is abolished in every section. Graded production suitably selected giving the maximum variety of experience is substituted from the beginning. Again difficulties occur: the right type of instructor is not easily found; the cost of scrap may prove serious, unless carefully watched; the attitude of interested people may not always be sympathetic, and last, but by no means least, delivery is a formidable trouble. On the other side the advantages are overwhelming. A student is interested, keen, and enthusiastic; he feels that he is working to some purpose, and that his work has a value which can be assessed commercially within his own experience, his practical work is in direct and constant touch with his theory in the lecture room and laboratory. At the end of a fifth-year course he has had a reasonably wide experience for a young man of his age, and he knows something of the relative costs of the application of his theoretical knowledge.

The 'acid test' of any scheme is shown by its results. So far the appreciation of industry of this form of training is interpreted in the fact that students thus trained can be placed without difficulty.

Mr. A. P. M. FLEMING.—*Educational Facilities offered by Industry.*

The portion of the subject assigned to the writer is to indicate how industrial firms themselves have attempted to provide suitable educational facilities for their workers.

The attempts that firms have made to provide educational facilities of a more or less conventional type have, perhaps, led many who are not intimately associated with industry to form an entirely wrong conception of industrial educational needs; and, more particularly, of what those responsible for the conduct of industry believe to be its educational needs. In this paper it is proposed only to touch upon the more conventional facilities, but rather to indicate those which do not fall directly within the recognised scope of education, whereas industrially they are educational efforts of the most vital kind and apply equally to all types of workers, whether manual or mental.

The fundamental factor in industry is personnel, and the educational needs of personnel—industrially and individually—are to fit the worker for his environment, whatever it may be.

Industrial environment is continually changing, and conditions at the present time call for educational effort which will produce an appreciation of the need, to the community, for intensive production; the ability to work effectively in a 'team'; and to exercise independent judgment based on an accurate appreciation of facts; a spirit of fairness towards one's fellows; an instinctive desire to improve the means of productive effort in the service of the community; and all the other attributes that go to the making of a good citizen.

While it is recognised that these qualities, which are essential to fitting a worker for his environment, can, in a general way, be developed through the more conventional educational facilities, the need for the exercise of them cannot be fully appreciated by the juvenile until he enters his working environment, so that it is not until then that the best opportunities for such development occur.

To some extent organisations of the type represented by the Boy Scouts do much to fit the young worker for his industrial environment, but something much more intimately associated with his work is needed. The writer will outline the types of organisations that exist in some of the large industrial concerns in which the juvenile workers are not only given training facilities which enable them to follow effectively their own particular trade or vocation, but which provide the means for training in those aspects of industrial life that involve relationships with their fellows—whether in work, play or in the general communal relations that exist between all sections and classes of workers associated together for industrial production.

Facilities for continuing this form of education in adult years are needed, and the most satisfactory are those which arise from the outworkings of societies and institutions which are identified with a man's work, or with the welfare of himself and his fellows. Thus, in all the healthy industrial concerns in which sports and general and social activities of every kind are being pursued very actively, the real education of fitting a man for his environment is going forward effectively.

To gauge the importance of this type of education, one must bear in mind that in a country like Great Britain, industry is a fundamental necessity to the entire nation, and everything that operates against national prosperity eventually diminishes the well-being of every individual. One of the most lamentable features operating against national prosperity is the unrest and want of agreement that exists between employees and the management of industry. An analysis of conditions shows that many of the factors referred to above are involved, and it would seem that the only way of satisfying the educational requirements they represent lies in making the very best and fullest use of the experience of the worker in his particular sphere.

This 'non-conventional' type of education must necessarily be closely linked with the more conventional training of the worker for his job and in the general, scientific, and economic principles underlying it. In so far as employment is concerned, it should aim at off-setting the general tendency to 'safety first' in any job and create the outlook that industry has all the attractions of adventure. The instruction in economics should enable the worker to appreciate the various factors that govern raw material supply, and should enable him to exercise judgment as to the possibility

offered to him by employment overseas in the development of the vast field of undeveloped resources that is needed to feed the fast-developing manufacturing resources of the home country.

Demonstration of *The Work of the Leeds Schools Music and Drama League*. Address by Sir HENRY HADOW, C.B.E.

Tuesday, September 6.

Discussion on *School Examinations*. Dr. P. B. BALLARD, Dr. J. M. CROFTS, Mr. B. C. WALLIS, Mr. J. H. ARNOLD.

Dr. P. B. BALLARD.—*The Art of Examining Children*.

Examining is measuring, and the very essence of measurement is accuracy. Hence modern efforts at the reform of examinations aim at making the testing objective. An attempt is made to eliminate so far as may be the element of chance. Luck enters largely into the current examination system which tests knowledge by very limited samples, and uses formal English composition almost exclusively as the mode of response. As a result the testing has a low degree of 'reliability,' in the technical sense of that word.

An examination may be diagnostic, or evaluative, or competitive. The purpose of the examination determines its content and its difficulty. It is rare that an examination can adequately serve more than one of the purposes referred to above. Whatever its purpose, however, it should satisfy certain criteria. It should, so far as possible, distinguish between promise and performance; it should be independent of the personality and mood of examiner; it should be reliable in the sense that a similar examination given the same candidates on, say, the following day would yield virtually the same results; and it should cover a reasonably wide field of knowledge and capacity. The modern tendency is towards a large number of brief questions easy to mark, instead of a small number of questions difficult, if not impossible, to mark.

Dr. J. M. CROFTS.—*The First and Second School Certificate Examinations and Standardisation of Results*.

An account is given of the procedure followed by most examining bodies in an endeavour to standardise their results; the procedure affects appointment of examiners, setting papers, and, above all, marking scripts. It is shown that it is comparatively easy for examiners to place a batch of candidates in order of merit, but that there is no certainty of opinion as to where the pass line should be drawn. The chief examiners in a subject review the standard of marking adopted by each assistant examiner, and apply such corrections to his scale of marking as they deem necessary. There is no guarantee, however, that the chief examiners have adopted the right standard; they are always examiners of much experience, and doubtless they are fairly successful in obtaining a satisfactory standard, but they have no absolute unit of measurement to go by, they can give only their personal opinion, and testing of this personal opinion shows a very considerable variation among experienced examiners. It is suggested that where the number of candidates is large, it is fair to assume that approximately the same percentage should pass from year to year. Such an assumption cannot be proved, but it is supported by the constant difference in performance between boys and girls over a series of years as regards standard of work sent in, and in the dispersion of the frequencies of distribution.

For the Higher School Certificate Examination, on which many scholarships are awarded, other considerations enter, as the value of marks in literary subjects has to be balanced against those in scientific or other subjects, and different types of distribution curves are obtained in different groups of subjects. It is suggested that the marks as sent in by the examiners should be modified so that they all conform to the same type of curve, and so equate the chances for scholarships of candidates in different groups.

Mr. B. C. WALLIS.—*The Position of the School Inspector.*

1. Four parties are primarily concerned with external school examinations—the examinees, the teachers, the examiners, and the examining authority. The school inspector represents the teachers and the authority.

2. Theoretically the examiner and the inspector are antagonistic.

3. Bad examination traditions: (a) Examinations require preparation; (b) Examinations should tend to improve teaching. The examiner postulates complete freedom in setting his tests; the inspector limits his activities in the interests of the schools, *i.e.* of the non-examinees.

4. The examiner regards each examination as a unique phenomenon; the inspector considers it as part of a series, part of the machinery of inspecting the schools.

5. The inspector regards the examiner as a potent factor in education and holds that the examiner should say how the examinees have been taught. The examiner replies (a) that similar groups of candidates at an identical examination in London and Birmingham would perform differently; (b) that boys and girls always perform differently, and (c) that he has no grounds for the judgment that either London children or boys are relatively well or badly taught.

6. (i) The good teacher is not necessarily a good examiner; (ii) the specialist teacher is probably a bad examiner; (iii) the inspector deals with averages, the examiner with departures from the average; (iv) examiners should be free from the constraint now imposed by teachers and inspectors; (v) examiners should be specialists in examining, with sure appointments over long periods in order to have time for the necessary research into the conditions and consequences of their labours.

Mr. J. H. ARNOLD.—*First School Examinations in Secondary Schools.*

A. *General Function*: To test results of courses of general education (teaching) in a particular class of schools forming part of a national system of education.

B. *Specific Functions*: *Legitimate*—to test actual knowledge, ability to marshal facts, and ability to apply facts, by simple processes of induction and deduction, to the solution of ordinary problems—to act as an incentive in secondary school work—to furnish schools with an independent estimate of the results of that work. *Illegitimate*—unnecessarily to limit curricula and subject syllabuses—to attempt to guide, or to criticise, the work of the schools.

C. *Standard (pass)*—such as may be fairly expected of pupils of reasonable industry and ordinary intelligence—complication through intrusion of University Entrance standards (credits).

D. *Equality of Standard*—necessary because of a national system of education (A above); complications through multiplicity of examining bodies.

E. *Two methods of Equalisation*—(1) reliance upon (a) attempted standardisation of difficulty of papers set, and (b) impressionism by examiners; (2) assumption that average standard of large number of candidates does not vary greatly from year to year. *Second method far preferable*—not based wholly on theory of probabilities—gives a *relative*, not a merely *arbitrary*, standard by connecting credits with numbers of candidates—not absolutely accurate but fairer than ‘impressionism’ which results in anomalies and injustice. The ‘don’t cheapen the examination’ bogey.

F. *Curricula*: Examining bodies’ duty to examine on curricula followed by schools and approved by Board of Education—no limitation to subjects that can be taught only ‘academically’—via media—‘a reasonable demand.’

G. *Syllabuses*: Attempts to ‘lead’ schools or encourage particular teaching methods are unwarrantable interference—need to minimise so far as possible the unavoidable effects of working to ‘outside’ syllabuses—handicap on new, and experimental, teaching methods.

H. *Papers*: Easy questions and strict marking—stern discouragement of ‘cram’ questions—phrasing; that of the ‘adolescent,’ not that of the ‘cultured adult.’

J. *Publicity*: Publication of general methods of marking and, in particular, of percentages of ‘credits’ in individual subjects essential—fears of trivial and carping criticisms groundless—secrecy breeds suspicion.

K. *Co-operation*: Examining bodies must know what the schools are doing; otherwise examination not a fair test—appreciation by schools of real co-operation—no attempt to ‘run’ examinations.

L. Conclusion: Commercialisation of 'results' through advertisement; school authorities, not examiners, to blame; what examinations cannot do; overwork; examinations should be recognised for what they are—a partial test of one aspect only of education.

SECTION M.—AGRICULTURE.

(For references to the publication elsewhere of communications entered in the following list of transactions, see p. 435.)

Thursday, September 1.

Mr. J. STRACHAN.—*Arable Dairy Farming*. Followed by Discussion: Sir JOHN RUSSELL, F.R.S.; Mr. W. R. PEEL; Mr. J. H. HELLIER.

Presidential Address by Mr. C. G. T. MORISON on *Agriculture and National Education*. (See p. 202.) Followed by Discussion: Mr. J. L. HOLLAND; Mr. H. W. COUSINS.

AFTERNOON.

Visit to Laboratories of the British Research Association for the Woollen and Worsted Industries, Torrington. (See page 411.)

Friday, September 2.

Joint Discussion with Section K on *Control of Plant Diseases*. Mrs. ALCOCK; Dr. W. B. BRIERLEY; Mr. W. A. MILLARD.

Prof. J. SEBELIEN.—*Study and Development of Agricultural Science in Norway*.

It is stated in this paper that, in spite of the unproductiveness of 71 per cent. of the Norwegian area, and in spite of the fact that Norway is the most pronounced small-farming country of the world, agriculture and forestry are of considerable importance. The output of the small but intensively manured plots has always been fairly large, and Norway grows still more grain on the same area than most of the better situated countries of Europe.

Since the establishment of the first agricultural school in 1812, there have grown up a number of such schools in every county, subsidised partly by the State, partly by the counties. Besides these, the Royal Agricultural College at Aas, established in 1859, has been the centre for the more scientific education for practical farmers and for teachers and other public functionaries, also for scientific research and experimental work on behalf of agriculture. The institution is, after its thorough reorganisation in 1898, working on five lines: agriculture, forestry, horticulture, dairying and surveying. The teaching staff consists of 32 professors and lecturers and about 16 assistants. The course is for 2½ years, but the students have, before admission, to guarantee their fully practical education and acquaintance with the manual labour of their profession, besides the necessary previous theoretical knowledge. The yearly subsidy from the State to the college has in this century varied from about £8,000 to £77,300.

Of the problems discussed and worked upon in the different departments of the college are mentioned:

The experiments for plant culture and plant breeding. These have resulted in a lot of new sorts of fodder plants, potatoes and grasses, furnishing the different parts of Norway with sorts of greater economical value than those of former days.

The same may be said of the researches in horticulture, not only about new breeds of vegetables, but also about the substitution of horse-manure in hot beds with electrical heating. This is shown to be not only very economical in Norway, but it has a good influence on the quality of the crop.

The researches in electroculture in different ways have given results which are shortly reported.

In the department of forestry a number of extended investigations are going on about different systems for utilising the forest, and other experiments with trees and seeds of different sorts.

The investigations in feeding domestic animals are mentioned, especially the results with feeding milk-cows and pigs with herrings, herring meal, cod-liver meal and whale meal.

It is mentioned that the Norwegian experiments on the heredity of lethal achondroplasia are in collaboration with the parallel experiments of Dr. Crew at Edinburgh.

Regarding the geological and soil science there are mentioned the researches of the composition and the acidity of soils from different parts of Norway, as also the nitrification in Norwegian soils.

Experiments with fertilizers and manure have been executed in different parts of the country by a number of investigators. The pot-experiments, hitherto mostly from the chemical laboratory of the College at Aas, are described.

Finally are mentioned the experiments belonging to analytical and pure chemistry, botany and dairy-researches, also the institute for trying new machinery for agricultural purposes.

It is stated that agriculturalists and foresters in Norway on the whole have utilized the instructions and scientific results presented to them, and it is hoped that their good fund of knowledge, being on the whole at a level with the most progressive nations of Europe, will help them through the bad times ruling Norway as well as most nations of Europe.

Capt. C. W. HUME.—*The Slaughtering of Animals for Food.*

An ideal system of slaughtering must be (a) humane, no pain or fear being inflicted; (b) hygiene, the carcasses being adequately bled, prepared in clean conditions, and uniformly inspected for disease, and (c) commercially profitable, so as to enable home-killed meat to compete on favourable terms with imported meat.

Humane Considerations.—The knocking-down box should be installed in every slaughter-house, as it enables beasts to be positioned for slaughter without preliminary struggling. Slaughter-men should be trained and licensed on a nationally controlled system. Public abattoirs would facilitate supervision for humane purposes.

The poll-axe (used for stunning animals which are large enough to give trouble) is less accurate than the captive bolt which can be made practically infallible. Sheep and lambs are not stunned, as they do not offer much resistance.

Pigs are hoisted by one leg and stuck: in cases where squealing is an objection they are stunned with a hammer. In Great Britain the old-fashioned methods are used for about 15 million animals per annum, while the pistol is used for about one million. Great Britain and America are less humane in this respect than the Teutonic countries of the Continent.

The Jewish (ritual) method of slaughtering is particularly open to criticism as regards the methods employed for casting large beasts. The Weinberg Casting Pen is believed to offer a solution of this difficulty.

Hygienic Considerations.—Slaughtering should be centralised in large (e.g. public) abattoirs, but in England it is impossible to make the butchers use these when they have been built, and the abolition of the competing private slaughter-houses is opposed by vested interests.

The persistent prejudice to the effect that the use of the mechanical poll-axe (pistol) hinders bleeding and causes 'splashed' pork has been finally refuted by the City of London inquiry.

Bleeding depends on a number of factors—the time elapsing between stunning and bleeding, fatigue, the nature and condition of the animal, and the skill of the slaughterman.

Commercial Considerations.—It is suggested that if home-killed meat could be certified as hygienic and humanely killed, and advertised as such, the effect on the market would be favourable. The City of London report has refuted trade objections to the humane pistol, except that in the case of sheep and lambs its use involves slightly more trouble, and that the inquiry did not extend to bacon pigs.

General Situation.—The Ministry of Health recommends the use of the pistol (Model By-law 9b), but in view of opposition from the Meat Traders' Federation the

Government does not enforce this nationally. It throws the onus of decision on the local authorities, and the City of London and other local authorities throw the onus on the Ministry of Health, on the ground that the by-law works unfairly unless nationally enforced. An impasse has therefore been reached.

Conclusion.—It is suggested that the British Association should appoint a committee to inquire into the available evidence as to the desirability of (a) the national as distinct from local regulation of methods of slaughter; (b) control of the training and licensing of slaughtermen; (c) abolition of unsuitable slaughter-houses when central slaughter-houses are available.

Prof. N. M. COMBER.—*The Teaching and Research Work on Soil Chemistry.*

Mr. W. A. MILLARD.—*Demonstration Work on Scab of Potatoes.*

Mr. S. BARR.—*Internal Rust Spot.*

Mr. T. H. TAYLOR.—*Potato Eel Worm.*

Mr. W. D. D. JARDINE.—*Warping* (illustrated by cinematograph films).

Mr. C. V. DAWE.—*A Yorkshire Township: Its enclosure and subsequent agricultural development.*

Saturday, September 3.

Pedological excursion to Horsforth, Lawnswood, Otley Chevin, Dunkswick, Harlow Quarry, Hook Moor, Halton, Templenewsam Park.

Monday, September 5.

Discussion on the *Production and Distribution of Milk*. Speakers: Dr. A. G. RUSTON; Mr. J. A. VENN; Mr. J. WYLLIE; Mr. V. LIVERSAGE.

Mr. J. A. McMILLAN.—*Winter Feeding of Sheep at Garforth.*

This paper deals with feeding trials carried out at the Leeds University Farm during the winters of 1925-26 and 1926-27.

The chief objects of the trials were to compare rations of:—

- (a) Roots alone; roots and hay; roots, hay and concentrated foods.
- (b) Concentrated foods of high, moderate, and low protein content.
- (c) Concentrated foods of high protein content (including and excluding linseed cake).

There were twenty hogs in each lot in the 1925-26 trial, and twenty-five in each lot in the 1926-27 trial. Roots and hay were allowed *ad lib.* in each case.

The results of the two tests show that the high protein rations produced the best live weight increase, and that the sheep receiving these rations also fattened more quickly. The health of the sheep did not appear to be affected adversely by any of the rations.

Mr. C. G. A. ROBERTSON.—*Farming in the Industrial Area of the West Riding.*

The soils of the area are briefly described, and some of the problems connected with the management of both arable and grass land discussed. The farming practice and its relation to the conditions, also the stock and their management, are described. Brief reference is made to rhubarb farming, which is a feature of the Leeds area.

AFTERNOON.

Excursion to the works of Messrs. John Fowler & Co., Leeds (Steam Plough and Locomotive Works).

Tuesday, September 6.

MORNING.

Discussion on *Soil Surveys.* Sir JOHN RUSSELL, F.R.S. ; Prof. G. W. ROBINSON ; Prof. J. HENDRICK ; Prof. N. M. COMBER ; Dr. W. G. OGG ; Mr. W. MORLEY DAVIES.

Sir JOHN RUSSELL, F.R.S.—Soil surveys are an old activity of British agricultural experts, the first having been made at the end of the eighteenth century by the simple method of inspection ; the purpose was to obtain information as to the existing state of agriculture and to offer suggestions for improvement. No other general survey was made until after 1894, when the present system of agricultural education came in ; it was then conducted on wholly different lines. The Rothamsted experiments had emphasised the importance, for crop production, of nitrogen, potassium and phosphorus ; chemists had developed methods for estimating the amounts of these in the soil, and for forming an estimate of the probable response of the crop to fertilisers. The staffs of the Colleges carried out fertiliser experiments which met with considerable success ; the idea developed of making soil surveys which would help the farmer in his fertiliser practice and soil management generally. Thus, the British surveys were from the outset intended to describe the soil as a medium for crop production ; the analytical work was directed to the discovery of the amount of plant nutrients present and the depth of sampling was fixed at 0"-9" for the surface layer, and 9"-18" for the lower layer, these being regarded as average root ranges for shallow and deep-rooting crops respectively. The American surveys were on essentially the same lines : they were started in 1860 to afford guidance for the development and improvement of agriculture and they were based on the view that the soil was a prime agent in crop production. Through the influence of Milton Whitney, and probably resulting from his early interest in the tobacco crop, which is profoundly affected by soil type, the American workers attached more importance to mechanical analysis than to the estimation of plant nutrients. Hall and Russell combined both methods and studied soil type as well as chemical composition.

Meanwhile the Russian workers were studying the soil quite apart from its crop-producing power. They, like the British workers, had laid out fertiliser experiments which were under the charge of Mendeléeff, then in his youth ; but these experiments, unlike the British, had given negative results, so that they were given up and Mendeléeff returned to pure chemistry, to discover the Periodic Law. But they had shown the importance of soil types, and the Free Economic Society which had fostered them invited Dokuchaiev to study the chernozem. He ignored agricultural considerations entirely and studied the soil simply as a distinct natural object, restricting himself also to its morphology, with results now known through the writings of Glinka. He was followed by a number of Russian workers who have made soil morphology essentially a Russian subject ; their work has had considerable influence in Britain and America.

The British workers had long recognised that soil analysis could at best only afford comparisons of one soil with another, and they had studied numerous methods of describing the soil. They had, however, retained the two depths, 0"-9" and 9"-18". The Russian workers frankly discarded any connection with crop producing power, and showed that inspection of the profile gave a much more rational indication for the depth of sampling.

In practice the soil surveyor in Britain is compelled to cover a moderately large area of land and the soils do not as a rule fit in with any of the Russian groups ; they are influenced more by the nature of the parent material than by the climate. Consequently the geological map affords the best basis of surveying, especially for all formations down to the Devonian, though for the lower ones it appears less useful. The boundaries do not quite agree with those of the geologist because of local slipping or drifting, and in regions of much drift the geological basis may lose much of its significance. The surveyor records the general nature of the ground, its configuration, stoniness and state of drainage, also the colour, texture and reaction of the soil ; these particulars are recorded for the various layers down to the underlying rock. Soils of similar appearance are mapped similarly, but in practice mapping is often a difficult operation. Useful guidance may be obtained from a study of the vegetation of the different areas.

For small areas, such as an experimental farm, where the parent material may be the same throughout, and where configuration and micro relief are very important, the dynamometer affords a useful method of surveying the soil.

Continents give the widest scope for the surveyor, for here all groups of soil are found; the great climatic zones form the first great groups, within these come divisions based on the nature of the parent material, and within these again the smaller divisions based on local sorting out of soil materials resulting from configuration of the land; finally, there come the subdivisions due to the micro relief.

Prof. G. W. ROBINSON.—From the standpoint of the practical soil surveyor, the present question dates from the pioneer work of Sir A. D. Hall and Sir E. J. Russell in Kent, Surrey and Sussex. In their survey, soils were classified according to their parent geological formation. The geological map, with certain adjustments, was also the soil map. Various soil surveys have been executed since the publication of Hall and Russell's work, and it has been found that the geological classification of soils is not always applicable. Considerable interest has been aroused in the Russian work on soil classification, but although we have learnt the importance of profile studies, we cannot entirely adopt the Russian system as applicable to this country. For the present, our task is to collect important data such as surface, relief, texture, water conditions, colour and stoniness. Above all, profile descriptions are required. While a soil map based on profile would be very valuable, since profile is the summation of the effect of a number of factors each of which can operate in a number of different ways, the number of kinds of profiles is likely to be too large for practicable mapping. It might be better in generalising from the 6" field maps, on which all data are recorded, to make more than one 1" map. For example, one map might show the nature of the parent material, another the texture of the surface soil, and a third the character of the drainage conditions. For the present, our task is to collect data and to generalise from these data in such a way as to bring together into classes those soils which are most nearly alike, leaving for the future the work of synthesising those regional classifications into a more comprehensive scheme.

Prof. J. HENDRICK.—There are at present considerable differences of opinion in this country as to the methods of soil survey and mapping. The importance of uniformity was emphasised. The soil maps of a country should all be prepared on a uniform system or else their usefulness is greatly diminished.

There are three great factors on which the nature of a soil depends: (1) the materials from which it is derived, the rocks and organic materials from which it has been formed; (2) the climate in which it was formed; and (3) the topography of the place where it was formed. The vegetation does not form an independent factor, as it depends on the other three and in turn reacts upon the nature of the soil. All of these factors have long been recognised, but we have in recent times made much advance in our knowledge of their action, and have in particular learnt much about the climatic factor. We have also learnt that the resultant of all these factors is expressed in the soil profile. The modern views of soil profile are only a development of the earlier division of the subject into soil and subsoil. As the profile expresses the result of all the soil-forming agencies, the best method of mapping soils is in terms of profiles. We require to get busy and collect and tabulate accurately the facts as to soil profiles; when we have collected a sufficient body of facts they will require to be classified and the result expressed by means of soil maps. As knowledge accumulates, the value of such maps will ever increase.

Prof. N. M. COMBER.—Surveying and mapping soils on the basis of the soil profile has two important characteristics.

(1) *It considers the soil as a whole.*—No other process of classification does this. It is frequently said, referring to a particular area, that the soil has a certain mechanical composition, which statement implies that the mechanical analysis of the soil is uniform throughout its depth. Except in the case of certain new warp soils this is probably never true. The study of the profile differentiates between the texture factors of different horizons. The same consideration applies to any other characteristic which may be studied separately in each horizon.

(2) *It takes cognisance of the soil-formation processes.*—The processes going on in a soil effect removals, leachings and depositions and the soil profile reflects these processes. The importance of this cannot be exaggerated, for it is a philosophical necessity that one cannot claim a scientific knowledge of soil without a knowledge and understanding of what has gone on in its formation, and what is still going on

within it. Hitherto there has been too great a tendency to consider the soil statically, and to try to visualise its constitution as a fixed thing.

Immature, Cultivated and Sedimentary-rock Soils.—In soils which are immature and in which the soil processes have not had full play, some of the characteristics of the parent material still obtain. The characterisation of such soils involves a combination of the two considerations, namely, the parent material and the processes acting upon it.

In cultivated soils the upper part of the natural profile is disturbed by cultivation processes which prevent the formation of horizons within the depth of their influence, and tend to make the soils uniform. This disturbance of the upper horizon or horizons may have considerable effect upon the lower horizons.

Soils which are formed from sedimentary rocks such as the clays and sands of this country will not, under uniform weathering conditions, ultimately become alike in all respects. The rocks from which they are formed are the results of a sorting-out process in which the larger particles have been approximately separated from the smaller ones.

It may be thought that the considerations underlying the genetic classification of soils are of less importance in all these cases and, therefore, of less importance in this country. There is, however, a sense in which those considerations are of *greater* importance in the study of such soils. Crudely speaking, the soil processes have gone on to the utmost in the mature soils, and the processes are easily discovered by the examination of the soil. In the immature and cultivated soils the processes are going on and the soil itself does not so clearly indicate what these processes are. But the knowledge of these processes is equally important; indeed, it is fundamentally important. The study of the soil-formation processes is much *more* difficult in a country of immature and cultivated soils than in a country of mature soils, but it cannot possibly be less important.

Dr. W. G. OGG.—*The Soil Profile as a Basis for Intensive Soil Surveying.*

It is now generally agreed that the broader grouping of soils is most satisfactorily based on climatic factors. These find expression in the soil profile and boundaries between the great climatic types can be decided by an examination of the profile.

There is not, however, the same consensus of opinion on the question of intensive surveys.

Minor modifications of the profile occur within each of the broad climatic types. These may be due to the parent material (origin, method of deposition, &c.), topography, drainage, and other causes. There appears to be no reason why these minor profile differences should not be used in field mapping, and there seems to be every likelihood that a system which takes account of the whole profile will yield more useful results than those which take account of a single character or a single layer. Vegetation differences have been found to be closely linked up with differences in the profile and without changing the basis of mapping, the vegetation may be used to facilitate the fixing of profile boundaries.

It is probably too soon to attempt to evolve a scheme of classification for intensive work. Mapping, however, can be carried out and the profile differences found should be described with explanations, where possible, of the features observed. The amount of detail will, of course, depend on the scale of mapping.

There is urgent need at present for the definition of texture and colour and standards to be employed in field work, and also for the clearer definition of such terms as soil 'type,' 'variety,' &c.

Mr. W. MORLEY DAVIES.—I feel that the remarks of Prof. Hendrick are of considerable importance. In an area as small as Britain, with similar climatic and agricultural conditions, concordance as to method seems to be essential. Furthermore, I agree with Mr. Morison that the practical side of the question cannot be totally disregarded. The needs of the agriculturist, standing as they do at present, necessitate that this interest should be in the mind of the surveyor when deciding on a scheme of survey.

It would be a pity if the meeting obtained the opinion that the methods suggested were all at variance. As a matter of fact, considerable uniformity holds, everyone is agreed as to the essential data to be collected. It is in the fashion that this data should be presented where a difference of opinion is apparent. It is probable that this difference will gradually disappear when co-ordinated work brings the individuals involved together, with an opportunity for discussion in the field, as distinct from the conference room.

Discussion on *Plot Technique*. Dr. R. A. FISHER; Mr. T. EDEN;
Dr. E. S. BEAVEN; Mr. A. MILLAR.

Dr. R. A. FISHER.—The development of modern methods of plot arrangement is intimately connected with the development of an exact statistical technique for examining the results obtained. This goes back to 'Student's' paper of 1908. A compact arithmetical procedure is now in use, called the Analysis of Variance, which embodies the exact treatment developed from 'Student's' method. The essence of this method of analysis lies in dividing the total amount of variation observed between the plot yields into separate portions, some representing experimental effects to be utilised, others, perhaps, experimental effects to be eliminated, while at least one portion represents the experimental errors to which the results are liable. To each portion is assigned a definite number representing the degrees of freedom, and these numbers depend on the structure of the experimental design; the analysis into degrees of freedom is useful, not only in guiding the arithmetical procedure in the analysis of the results, but in determining to what questions a given experiment could give definite answers, and how many independent comparisons would be available to answer each such question.

The first step towards the development of a sound field technique was taken in the uniformity trials, such as those of Wood and Stratton and of Mercer and Hall in 1910. These showed unmistakably that by far the greater part of the errors of field experimentation were due to soil heterogeneity, and only much smaller errors were introduced in the measurement of the land, the separation and weighing of produce, &c. The errors due to soil heterogeneity can be reduced by (1) replication, or assigning to each treatment or variety a number of plots, and (2) the elimination of certain components of the soil heterogeneity which, as the uniformity trials also show, is best done by eliminating the differences in fertility between whole areas, rows, columns or blocks containing a number of adjacent plots. When such elimination is effected in the field it is essential that it shall also be done in the statistical procedure by which the experimental error is estimated; equally it is important that the portion of the soil heterogeneity which is not eliminated shall be deliberately randomised, in order that the estimated error shall correspond to the real errors affecting the results. Personal judgment of a fair distribution of plots is not a satisfactory substitute for actual randomisation. Slides were exhibited illustrating the lessons of uniformity trials, and some of the field arrangements adopted this year at Rothamsted based upon these principles of experimental design.

Dr. E. S. BEAVEN said that he had been conducting replicated experiments with cereals for the last twenty years, but only for comparisons of yield of different varieties, and he would refer only to such trials. Seven years ago he designed the half-drill strip method for field experiments (*Jrl. Min. Agr.*, Nos. 4 and 5, 1922), and this had been adopted by the National Institute of Agricultural Botany at their stations in various parts of England for the past five years. Replication was the first essential, and the question whether the arrangement of the plots should be systematic or 'randomised' was of comparatively minor moment. A diagram which was exhibited showed that the same number of replications could be obtained on the same area in the case of yield trials of varieties by this method as by Dr. Fisher's method, and it might be strongly contended that the small increase of accuracy, if any, obtained by the 'Latin Square' method was of much less moment than its practicability under field conditions. The 'Latin Square' method was impossible, or at least extremely difficult, of execution in trials of varieties with the customary implements of husbandry. In an agricultural section it was hardly necessary to say that it was not possible to lift and transport drills and reaping machines from plot to plot by aeroplanes. It was necessary to use horses or tractors—which could be done easily in the half-drill-strip system—but would present extraordinary difficulties in field plots laid out on the 'Latin Square' system. It was very necessary in the design of such trials not only to know the mathematical theory of probability applicable to such experiments, but also to have a knowledge of the material under investigation, and of agricultural practice.

A previous application of Dr. Fisher's theories of 'analysis of variance' and 'degrees of freedom' to an experiment in 1923 on 'Manurial response of different varieties of Potatoes' led to the conclusion that 'there is no significant variation in the response of different varieties to manure.' This appeared to be contrary to common sense. It was a well-established general proposition that races of the same

species *do* differ in their response to soil conditions; and manuring was obviously a method of varying soil condition. There was, in fact, abundant evidence to disprove Dr. Fisher's conclusion.

The statement that the error in field experiments was 'almost wholly' due to differences in soil fertility was far too sweeping. They also had to deal with weeds of all kinds, wireworm and numerous other insect pests, fungoid diseases of many kinds, also with rabbits, birds and field-mice. The list of causes of error might, in fact, be increased almost *ad infinitum*. As the diagram showed, some of these were more or less systematically, but most of them quite erratically, distributed.

In conclusion, the Lawes Agricultural Trust was to be congratulated on having at last, after so many years, accepted the principle of the desirability of replicating plots on different areas.

SPECIAL SESSIONS FOR TEXTILE SUBJECTS.

(For references to the publication elsewhere of communications entered in the following list of transactions, see p. 435.)

Thursday, September 1.

Dr. S. G. BARKER.—*Fading of Dyestuffs.*

Investigation of fading of dyestuffs shows that atmospheric influences and the conditions under which the exposures are made have a considerable effect on the amount of fading. Artificial light sources are compared with sunlight as regards constitution and fading power. It is shown that the carbon arc is the best artificial light for use as a fading agency. The influence of glass screens is discussed and experimental results quoted to show the influence of shop window glass on fading, &c. An outdoor fading cabinet and a new type of fading lamp giving controlled conditions of humidity, temperature and illumination at the surface of the pattern under test are described. The effect of tropical sunlight is compared with that of sunlight in England. Methods of measurement of the amount of fading, &c., are discussed.

Dr. J. J. HEDGES.—*Moisture Relations of Colloidal Fibres.*

Textile fibres are hygroscopic colloids, and their physical properties vary considerably with the amount of absorbed water. In the case of wool fibre the whole of the absorbed water is not removed by heating alone; the last $\frac{1}{2}$ per cent. of water being held very tenaciously.

During the absorption of moisture there is an evolution of heat, and for dry wool the amount is quite considerable (24.1 calories per gram). The amount of heat evolved by the textile fibres during absorption is given by a form of the Kirchoff equation for the heat of dilution of a solution.

Wool and its absorbed water behave like a two-phase system in which a little water is absorbed by the colloidal particles while the bulk is held in a system of pores. This hypothesis accounts for the lowering of vapour pressure of the water, the large apparent compression of the latter, the peculiar rate of evaporation curves, the change in length of a fibre under tension with change in moisture content, &c. The heat of absorption can also be accounted for in such a system by surface energy considerations. Under certain conditions, pores can be observed in textile fibres under the microscope.

The moisture content has a very definite effect on the electrical and thermal conductivity. This has been investigated by a number of observers, and their results are discussed in the paper.

The amount of water held also affects the fastness to light of absorbed dyes. With increasing moisture content, the dyes become more fugitive.

Visit to Laboratories of the British Research Association for the Woollen and Worsted Industries, Torrington. Papers:—

Mr. A. T. KING.—*The Chemical Aspect of Wool Research.*

This paper gives in the first place a general indication of the wide scope of chemical research in relation to wool and wool processes, and touches upon some of its more

outstanding points of contact, from the raw wool down to the finished products of manufacture, mainly in regard to practical considerations.

It then deals with underlying theoretical considerations imposed by the amphotene characteristic of wool substance exhibited in its sorptive capacity for acids and bases, especially in relation to sorption of alkali in scouring, together with the after-effects of sorbed alkali, and the method devised of locating the distribution of alkali and of demonstrating the origin of alkali faults.

A discussion follows of the present knowledge of the chemical nature of wool viewed simply as a natural organic product, and of its variability in composition as shown by the sulphur content, and also of the relation of the latter to differences in the physical structure of the fibre, and to biological considerations.

Further, the significance is discussed of the presence of the cystine nucleus in wool keratin, as applied to changes in the properties of wool on incipient hydrolysis and on exposure.

In conclusion, the promotion of pure research not directly on wool is instanced by a study of the bisulphite compounds of azo-dyestuffs, demanded by the encountering in practice of unexpected divergences from the accepted standards of fastness to stoving (bleaching with sulphur dioxide).

Mr. H. R. HIRST.—*Use of Ultra-violet Radiation in Textile Analysis.*

Radiation from a mercury vapour lamp, after passing through a Chance's Uviolet screen, is filtered, leaving rays of 4046 to 3022 A units; when allowed to fall upon a number of substances, gives rise to fluorescence. This fluorescence may appear as an ordinary colour or as an apparently self-luminous object. Examination of fibres of wool, cotton, silk, and artificial silks give distinctive colour impressions. Oils may be differentiated by their fluorescence into groups and the effect of oxidation is readily seen. Saturated and unsaturated hydrocarbons show marked difference. Esters of the indigoid type of dyes are fluorescent, and incomplete oxidation or hydrolysis can be detected with accuracy. This can be used as check on the dyeing process, so that more permanent colours can be obtained with certainty.

The effect of sunlight and atmosphere on dyed fabrics in some cases produces fluorescent compounds, whereby small amounts of fading, invisible by ordinary visual observation, are made evident.

Mr. H. PRIESTMAN and Mr. A. W. STEVENSON.—*Higher Drafts in Worsted Spinning.*

Drafting.—In worsted spinning, the 'top,' the product of combing and associated processes, is reduced to the size required for yarn formation by a series of drawing or drafting processes, about ten for the finer wools. As a matter of convenience, the material at each stage is wound on a bobbin and unwound for the next stage, the fibres thus approaching the rollers in a reverse direction compared with the previous process. From a convenience this reversal has come to be a trade axiom, and two drafts without reversal are believed to be impossible. The authors have developed an efficient spinning frame which makes two successive drafts.

The early attempts had just enough intermittent success to be encouraging, but fibres too frequently strayed and lapped on the various rollers, particularly the carriers. Only when the usual mechanism was abandoned and false twist introduced in the second draft did the experiments begin to be reliably successful. Merino roving, usually drafted six, is drafted thirty-six with ease. Crossbred wools have been dealt with in similar fashion with two false twist tubes in series, but it is quite probable that a single tube will be devised.

These experiments on successive drafting, while on the one hand foreshadowing possibilities in the elimination of machines and processes, on the other throw considerable light on what really happens in existing machinery.

Spinning.—Spinning mechanism of the cap type has been studied from various points of view. The first essential for such work was a stroboscope, and as none at the time on the market was suitable, one was developed. A revolving mirror produces intermittent illumination from an arc lamp beam, the instrument being robust in construction and giving an image of great brilliancy and precision. Peculiarities in the behaviour of the balloon such as 'cap licking' have been explained, and previously unsuspected variations in spindle speed noted and measured in the

laboratory and in the mills. Instruments have been devised for measuring the tension or 'drag' in the yarn (of the order of ten grams), not only as it leaves the front roller, but as it winds on the bobbin, the latter instrument revolving at 6000 r.p.m., and being used in conjunction with the stroboscope.

Mr. J. A. FRASER ROBERTS.—*The Inheritance of Some Colours and Patterns in Sheep.*

During the past four years the University College of North Wales, in association with the Animal Breeding Research Department, University of Edinburgh, has been conducting breeding experiments to determine the mode of inheritance of certain colours and patterns in sheep.

The following characters have been investigated :—

1. A dominant black in the Black Welsh breed.
2. A dominant black in the Piebald breed.
3. A brown modification of black.
4. The recessive black known in several breeds.
5. A highly characteristic pattern that has been called 'badger-face' and which is recessive to white.
6. Reversed badger-face pattern, in which the colours of the above pattern are exactly reversed; also recessive to white.
7. Piebald pattern, found to depend on a recessive factor that only acts on sheep that possess the constitution for self-colour.

The interrelations of the factors responsible for the production of these colours and patterns are in some cases curious and interesting. Badger-face pattern, reversed badger-face pattern, and recessive black appear to form with white a series of multiple allelomorphs. White crossed to the other three gives white; badger-face crossed to reversed badger-face and recessive black gives badger-face; the cross reversed badger-face \times recessive black has yet to be made. Dominant black segregates independently of badger-face pattern and is, therefore, presumably independent as regards the reversed pattern and recessive black also. The reversal of pigmentation in the case of badger-face and the reversed patterns is very striking. The form of the pattern is identical down to the smallest details, but those areas that are white in the badger-face are black in the reversed badger-face, and *vice versa*. This in conjunction with the probable existence of the multiple allelomorphic series already mentioned presents an unusual and interesting phenomenon. The modifications of colour, especially of black to grey and brown, would be of interest in connection with any attempt to develop coloured fleeces for the production of undyed fabrics.

Mr. J. E. NICHOLS.—*Coloured Fibres in the Fleece.*

Coloured fibres present one of the most serious objections to British wools from the point of view of the manufacturer, and also, in many breeds of sheep, of the breeder. But the presence of pigmented areas on the head and legs is considered highly desirable by the butcher in many localities; it is a matter of common observation that where the extremities are pigmented there is a tendency towards an admixture of pigmented fibres in the fleece. The problem of the elimination of these admixed coloured fibres is the most important if the clip is considered as a whole, and observations show that the solution of the problem lies in breeding and selection but is complicated by the influence of external conditions.

It may be considered that the basic coloration of the animals is determined by genetic factors, and the degree to which the colour is expressed is likewise conditioned. Observations have been made on the Suffolk breed where the darkness of extremities is most marked, and the great problem of the breeder is to limit definitely the pigmented areas. A study of the early coat of the lamb indicates that the first development of all kinds of fibres in this breed is accompanied by and includes deposition of pigment in the fibres; the lambs are born more or less dark in appearance, and the changes in coloration which follow as the lambs age take place in two directions and at different rates according to individuals. The extremities become darker, while the body area appears to become lighter in general appearance, because, in the latter case, of the gradual shedding of the coarser wholly pigmented fibres, and the lengthening of the finer fibres without further inclusion of pigment. It is possible to estimate the rates of change of gross coloration of extremities and body, and certain bases for selection for the ultimate freedom of the fleece from coloured fibres according to the changes in early life have been obtained.

Friday, September 2.

Visit to the Department of Textile Industries, University of Leeds.
Papers:—

Dr. F. W. DRY.—*Mendelian Breeding with Wensleydale Sheep.* (Preceded by exhibition of sheep illustrative of the paper.)

The main features in colour inheritance in the Wensleydale breed of sheep follow simple Mendelian lines. The occurrence of black lambs in white flocks therefore offers a favourable opportunity for applying Mendelism to a breeding problem in a large domestic animal. The successive steps in this undertaking are described, and certain practical considerations discussed. An attempt is now being made by the University of Leeds to build up a flock of pure whites.

Prof. A. F. BARKER.—*Race and Environment as affecting the Type of Sheep and the Wool Supplies of the World.*

Three fairly distinct lines of adjustment of race to environment may still be noted in making a survey of the sheep of the world. The first line is the most natural, that in which man has played no part, Nature only having taken the adjustment in hand. In the second line of adjustment, man has accidentally or incidentally interfered with Nature, but has consciously taken no part in deciding the line of evolution. In the third line, man has consciously and deliberately adjusted the race of sheep to the environment, and in some few cases has actually created the environment necessary for the evolution of a required type of animal.

If extent of distribution is some sort of a measure of the antiquity of a given type,¹ then it may be taken that the wild double-coated sheep of the Moufflon-Urial type is our primitive sheep, having representatives, more or less adjusted to the environment, in Asia, Europe and America.

It is, however, exceedingly difficult to find any large number of sheep in a perfectly open country which have not been interfered with by man—even the Soay and the Shetland sheep, although very near to the wild type, show traces of such interference. But the best example of the second line of adjustment is that now in evidence in Peru. The Spanish merino and the Spanish Park sheep (piebald) have there been introduced, as incidental to conquest, and for hundreds of years have been adjusting themselves to the table-lands some 12,000 to 14,000 feet up the Andes, with characteristic results which the wool manufacturer knows how to utilise in the production of his fabrics.

The third line of adjustment is practically in evidence in every wool-producing country in the world: New South Wales may be selected as a typical example. Here four zones, from the coast to the plains beyond the Blue Mountains, are to be noted, and for each of these zones the sheep-breeder has evolved a particular type of sheep yielding the best return possible in wool and mutton.

The conditions under which the several types of sheep have been reared are still reflected in the 'make-up' of particular breeds. Thus, the merino, accustomed to 'follow-my-leader' in the narrow valleys of Spain, still retains this character and often will not spread out over quite open pasture lands; while the English sheep—probably descended from a sheep brought across the central plain of Europe by nomadic tribes—naturally spreads out and forages to advantage. Merino ewes when grouped together hold their heads down in a characteristic fashion, and may transmit this peculiarity to their crossbred offspring. These and other characteristics are being observed in sheep and, properly understood, may enable the sheep-breeder to make the best possible adjustment of race to environment.

The Australian, South African, and other sheep breeders, acting on the lines of mass selection, have attempted to evolve the type of sheep best fitted to the environments with which they have to deal and, upon the whole, have been wonderfully successful. It is now being recognised that Mendelian characters, which so far have been the despair of the unscientific breeder, may now be reshuffled or readjusted, frequently just on the lines desired, and thus the required type of sheep produced. Type of coat, the casting of the outer hair (kemp), and retaining of the under coat

¹ Dr. Willis and Mr. G. Udny Yule on *The Plants of Ceylon*.

(wool), colour, horns, length of ears and of tail, and other less defined characters—sometimes probably linked together—may now often be treated as characters subject to normal Mendelian inheritance and, consequently, by suitable breeding procedure, a most useful adjustment of race to environment ensured.

MR. J. B. SPEAKMAN.—*The Intracellular Structure of the Wool Fibre.*

The gel structure of the wool fibre has found elucidation through a study of the stress-strain relationships of single fibres under varying rates of loading at various temperatures and humidities.

The relative positions of the constituent cells remain unchanged during the extension of single fibres so that the behaviour of the fibre as a whole is that of the single cell. The fibrillar structure within this cell is not arranged haphazardly, for the extension-load curves show a sharp bend towards the load axis at 30 per cent. extensions with finite rates of loading. There is, therefore, a tendency for the fibrillæ to lie along the axis of the fibre.

Fibres extended in water at 18° C. remain perfectly elastic even up to 70 per cent. extension, but such once-extended fibres are permanently more extensible at low tension. The point of incidence of permanent alteration of single fibres depends on the rate of loading, a fact which suggests plastic flow of fibrillæ under stress. This hypothesis has been confirmed in several independent ways. The permanent alteration of wool fibres by extension is due, therefore, to the rupture and plastic flow of fibrillæ. Perfect recovery is governed by the elastic cell wall and elastic fibrillæ; these draw back those fibrillæ which have taken permanent set and cause them to fold up within the cell.

Increasing humidity at constant temperature and increasing temperature at constant humidity both produce increased solvation of the wool substance. With increasing solvation, more and more fibrillæ become capable of showing plastic flow until the fibre as a whole is able to acquire permanent set. If extended wool fibres are cooled in the stretched position after immersion in water at a temperature above 60° C., they fail to return to their original length. The permanent set realised in this way is not due to a solution and redeposition of fibrillæ, but to plastic flow of all parts of the constituent cells, including the cell wall. Re-immersion of the *released* fibres in hot water invariably causes contraction. Even at 100° C. this contraction occurs to a marked degree, but the return to the original length is incomplete. In all cases contraction is due to a species of recrystallisation *within the fibrillæ*.

A comparative study of different wools, mohair, and human hair, showed that they differ considerably in plasticity. These differences have been measured and serve to explain the ease of manufacture of yarns and fabrics from merino as opposed to the coarser crossbred wools. The elastic strains imposed on fibres during manufacture are readily converted to plastic flow in the case of merino wools, whereas they persist in the case of crossbred wools, making them more wiry and difficult to control. The ability of wool fibres to dissipate elastic forces by plastic flow *at constant length* in the way here described has not hitherto been contemplated.

Monday, September 5.

DR. T. OLIVER.—*Predetermination of Wool Cloth Prices.*

Predetermination of cloth price must be based upon reliable costs. To fix a price on the basis that our competitors are likely to quote a certain figure is out of date. Without true costs the stability of a business must be uncertain. A manufacturer, with sound costing system, will never be afraid to quote a bed-rock price. Lowest cost per yard is no longer associated with lowest wages. A satisfied worker has a high economic value. Although estimates of cost cannot be absolutely exact, yet past experience will enable us to predetermine cost within narrow limits of error. A price-fixing system should be simple, not burdened with detail. Convenient to divide costs into (a) inanimate materials, (b) animate labour, (c) dead charges. Costs of materials and piece-work are easily ascertained. Manufacturing charges vary as (1) weight, (2) sett, (3) length, (4) value.

Initial processes (sorting, scouring, carbonising, dyeing, teasing, scribbling, combing) and wool oil entail pure weight charges; condensing, mixed weight-length charge; spinning-twisting introduce pure length variables.

Cost of yarn-making per finished ounce of cloth = $a + bc$.

(Where a and b are constants, c = yarn number.)

Cost of yarn-making per yard = $aw + bcw$.

But $w = he/c$, or $cw = he$, where h is a constant, e = sett, w = weight per yard.

Substituting, the cost of yarn-making per yard = $aw + bhe$, *i.e.* the sum of a weight charge and of a sett charge.

Warping, healding, sleying, winding, and weaving are mainly proportional to sett. For fancy cloths, a small constant term is usually added to the statement to make-up for extra work on coarse setts,

\therefore cost of weaving department, per yard = $f + ge$.

The mending department should be paid a percentage of the weaver's wages (say 70-75 per cent.). Cloth scouring, milling, finishing, and warehousing entail mixed length-weight costs. Scouring materials, water, steam, packing, carriage are costs proportional to weight. Commercial charges (selling, commission, patterns, interest on working capital, discount, insurance of stock, claims, &c.) are mainly relative to value.

So net price of cloth per yard = $Aw + Be + C$.

But usually $w = q/e$ (A, B, C, q , are constants).

Substituting and differentiating, we find that when $w = \sqrt{qB \div A}$ will be found the cheapest cloth, in the range of weights of a quality.

Example of Synthesis of a Selling Price Formula.

Cost of yarn per lb.	=	50	+ $\frac{2}{3}c$
„ „ oz. fin. cloth	=	3.5	+ $.046c$
„ „ yd. „	=	3.5w	+ $.046cw$
„ „ yd. „	=	3.5w	+ $.21e$
„ cloth manufacturing .	=		$.25e$
„ dyeing-finishng	=	.6w	+ 6
Net mill cost	=	4.1w	+ $.46e + 6$
Selling price	=	4.4w	+ $.6e + 6.5$
$(w = 4.6e/c, 14.4 \text{ oz. fin. per lb. yarn. Price} = \text{Mill cost} + 7\frac{1}{2} \text{ per cent.} + .1e \text{ profit})$			

Manufacturing profit is a variable circumscribed by very wide limits, because the factors assumed to control it seldom do. The usual way of assessing profit is by percentage on cost, which tends to make high-priced cloths too dear, and lower-priced cloths under cost. The best method of basing profit is on 'the productive hour,' because time is the chief controlling factor in business. A manufacturer has more to sell than his visible product. He places technical ability at his customer's disposal, *i.e.* service in the highest sense of the word.

Mr. E. E. CANNEY.—*Cotton-growing Policy: the Influence of Climate on Staple Quality.*

The finest cotton crops ever produced were grown in the islands off the coast of S. Carolina under singularly equable and genial climatic conditions during an abnormally long season. Taking these as the optimum conditions for cotton staple production as a whole, and examining the conditions under which other types of commercial importance are grown, gradients of severity down to excessively wet, dry, cold and cloudy margins and to variability extremes are clearly discernible. Parallel with them run varietal adaptations from the most delicately nurtured Sea Island variety to the distinct hardy varieties, producing corresponding ranges of staple quality from the finest Sea Island down to the coarse staples of poorest spinning quality. The harsher the conditions, *i.e.* in divergence from the old Sea Island optimum, the harder the appropriate type and the lower the staple quality appear the universal rule.

Neglect of this law largely explains the disappointingly slow rate of cotton-growing expansion in the new areas, where a bias for long staple production, irrespective of environmental considerations, has been consistently shown. Such a policy would be obviously inadvisable for the U.S.A. cotton belt, for instance, where it is plain that the disproportionately great loss in yield, in grade and crop security that excessive-staple policy invariably entails, would be to the advantage of neither the Lancashire spinner nor the growers. Yet the American cotton belt is much more

favourably situated, with respect to climatic conditions for cotton growing, than the majority of the new areas, where the penalty for the long-staple bias is the more serious.

The long-staple bias has hitherto had the support of the scientific plant breeders, who have held that staple quality is independent of climatic limitations and that, given the necessary experimental facilities in hybridisation and selection, the finer staples are producible in any area. After many hundreds of experiments the world over, and covering over twenty years of work, the results do not uphold their contention; and it is apparent that they are subject to the same climatic limitations that restricted the possible lines of development to the old plant breeders.

A change in staple policy to one that is sensitive to natural limitations is, therefore, urged as conducive to the best interests of the cotton trade and to the security of the growers in the new areas.

Dr. BARR and Miss HADFIELD.—*Nature of the Action of Sunlight on Cotton.*

Mr. F. T. PEIRCE.—*Problems of Textile Testing: (a) Variability; (b) Time Effects.*

Tuesday, September 6.

Mr. A. L. WYKES.—*Quantitative Determination of the Physical Properties of Artificial Silk and their Relationship to Textile Manufacture.*

After outlining the method of making artificial silk, it is shown that success in weaving, knitting, and braiding depends on a proper understanding of the physical properties of the yarn concerned. In the main, the numerous troubles met with in the manufacture of fabrics are due to the treating of artificial silk as if it were a simple substance, while, in fact, it is a complex of two substances with different physical properties. The two are described in this paper as 'locked' cellulose and 'dispersed' cellulose, and the general properties with load-extension and elasticity curves are described for each form. It is pointed out that these two substances are contained in ordinary viscose artificial silk in varying proportions, and that it is easy to convert one form into the other with consequent modification of the characteristics of the yarn. The effect of friction on an artificial silk thread is shown.

Common weaving and knitting faults are explained with reference to the theory advanced. Finally, recent improvements of commercial artificial silk are noted, and suggestions are made for its future development.

Mr. J. A. MATTHEW.—*Extensibility of Flax Yarns.*

A review is made of the work which has been done on the extensibility of flax yarns. The different experimental methods are described, and compared. The characteristics of stretch-load diagrams for flax yarns are described, and the methods of quantitative expression of these characteristics used by New and by the author are detailed and compared. The latter are concluded to be preferable since they cover the former with a fewer number of figures, the behaviour over the whole diagram is represented and the results from yarns of different sizes are directly comparable.

A method of analysis is described, based on the detection of irregular manufacturing conditions by means of the value of the ratio $\frac{\text{Total stretch } (yt)}{\text{Permanent stretch } yp}$. The characteristics of the diagram are expressed by the values $\frac{y_t}{y_p}$; Young's Modulus of Elasticity of the yarn (E); the equation to the total stretch-load curve $y_t = a_t x + \frac{1}{b_t} \log_{10} \frac{x_t}{x_i}$ where y_t = total stretch recorded on the diagram due to a load x ounces.

x_i = initial tension on the yarn in ounces.

$x_t = x + x_i$; and a factor K which may be determined by measurement whence E may be calculated for any desired conditions from the relation

$$E = \frac{16A}{K} \frac{(K-1) K (a_t + \frac{1}{b_t} \frac{1}{x} \log x_t)}{y_p} \frac{x_t}{y_p} \text{ where } \frac{K}{y_p} = \frac{y_t}{y_p}.$$

The ratio $\frac{y_t}{y_p}$ is a measure of the effects of tensions experienced by the yarn before testing, and the effect on the

stretch-load diagram is shown by the relation $b = k \left(\frac{y_t - 1}{y_p} \right)$ which is used to correct the experimental measurements for irregularities in manufacture.

The relations between the equation constants and the size of yarn, twist, length of specimen and rate of loading have been worked out. These may be used for correction of the effects of variants in yarn structure and so allow the effects of different kinds of fibre on the characteristics of the stretch-load diagrams to be determined. The constant b , is definitely shown to measure the effect due to slip of the fibre in the yarn, and large differences in this respect are shown to exist between different kinds of flax and hemp.

The general conclusion is that the longitudinal extension of flax yarns is a combination of several effects, the chief of which are indicated as a tightening up of the fibre strands on one another, the slip of the fibres past one another, elastic stretch of the fibre, and possibly permanent elongation of the fibre. The diagrams are similar in type for all kinds of flax yarns tested in the air dry condition, and there is no evidence of an increased rate of extension before breakage, so it is inferred that yarn breakage is mainly attributable to rupture of the fibre and fibre bundles and not excessive slippage. The conclusions drawn from tests employing a low constant rate of loading are confirmed by tests in which repeated applications of small stresses were employed. The bearing of these conclusions on the investigation of important practical problems is discussed.

REFERENCES.

G. F. NEW, *J. Text. Inst.*, 1922, 13, No. 2; 1926, 17, No. 9.

G. F. NEW and A. L. GREGSON, *J. Text. Inst.*, 1923, 14, No. 11.

J. A. MATTHEW, *J. Text. Inst.*, 1922, 13, No. 2; 1926, 17, No. 3; 1927, 18, No. 6.

DR. EZER GRIFFITHS, F.R.S.—‘Air Conditioning’ Experiments, and some Special Forms of Hygrometers.

An account is given of various researches bearing on ‘air conditioning.’ One problem was to devise means of controlling the humidity in rooms for the storage of fruit and eggs when the temperature was below normal atmospheric. The system employed was to circulate the air through brine spray and, since the density of the brine solution determined the vapour pressure, an automatic arrangement was devised to maintain the concentration within narrow limits.

Another investigation was concerned with the study of the cooling effect obtained with ducts placed on the external wall of a fruit stores: the air being circulated through the ducts either by natural convection or by forced air circulation. A duct whose surface was covered with moistened cloth gave a fourfold cooling effect compared with an uncovered duct. Ducts of various sections were also investigated.

Since the control element in several types of air-conditioning appliances is a material whose length varies with changes of humidity, a convenient form of apparatus has been devised for testing ten specimens simultaneously, and the results of tests are given in the paper.

A number of hygrometers are described which have been devised to meet special requirements. (a) The ‘fog formation’ hygrometer is based on the principle that fog forms in an atmosphere which is adiabatically expanded: the amount of expansion necessary for a fog which is just visible is a function of the humidity. (b) The resistance thermometer form of wet and dry bulb hygrometer described has an extremely small time lag. Cotton-covered wire carried on a glass frame is periodically dipped in water. The difference in temperature between wet and dry bulb is recorded by a string galvanometer. (c) The portable dew-point apparatus is a differential air thermometer, one bulb of which is so designed that it can be cooled by a stream of cold CO₂; the dew is observed on a polished portion of the bulb surface. (d) The ‘cellophane’ hygrometer is based on the change in weight with humidity of thin cellophane sheet. (e) The hygrometer for timber seasoning kilns is a wet and dry bulb hygrometer employing mercury in steel thermometers with both pointers indicating on the same dial. Arrangements are made for drawing air past the bulbs and for maintaining the covering over the wet bulb saturated with water.

The appendix to the paper contains a description of some typical air-conditioning installations of the water spray type.

DR. L. L. LLOYD.—Rancidification and Oxidation of Olive Oil.

CONFERENCE OF DELEGATES OF CORRESPONDING SOCIETIES.

ADDRESS BY

SIR FRANCIS G. OGILVIE, C.B., LL.D.,

PRESIDENT OF THE CONFERENCE.

I AM not qualified to speak with authority on any one of the specialist studies to which individual members of the Corresponding Societies give ardent and continued attention. I am among those who maintain an outsider's acquaintance with some of these studies, and who find, even in that, a source of many pleasures in daily life. We outsiders enjoy the byways of science. Your active members tread the highways and secondary roads from and to which the byways lead. The Corresponding Societies include members of all shades as to interest in science—from keen investigators who render frequent service in the advancement of science to those who merely toy with a hobby.

Yet all of us feel that these societies are a valuable national asset, and we wish to see a good annual return from that asset. Our aim is to promote life within our societies. Each wishes to promote his own society's usefulness to its members, its growth and its influence in its home area. In addressing you to-day I propose to discuss some matters that affect success in these aims.

Team Work.

My predecessor in this chair, Sir John Russell, addressed you on 'Regional Surveys,' and most matters of general interest to the Corresponding Societies of to-day are pertinent, directly or indirectly, to regional surveys. Indeed the aim of these surveys is to bring together in compact form and in reasoned relation considerations which emerge in the work of these societies. Thus the co-operation of every society, however specialised its aims, is most desirable for the progress and value of a regional survey.

Regional Survey is a fine field for team work, and within our several local societies team work is widespread—even if the 'team' has but two or three members. Group working is of the essence of our constitutions. In all the subjects in which we take interest comparative records are generally the result of the grouping of observations. For ready application this calls for, at least, a general agreement as to *matter* and *method*.

Vegetation Surveys.

Let us consider this in one particular matter of study. The preparation of a *Vegetation Survey* of an area gives added interest to the observations of members who make themselves responsible for individual sections of the work.

As a matter of fact the pioneer work in this matter—so far as the British Isles are concerned—has been carried out by single observers or by pairs, and it may be useful to remind you of some of these:—

1900.—R. Smith, then of University College, Dundee, published vegetation maps on a scale of 2 miles to 1 inch for—

- I. The Edinburgh district; and
- II. North Perthshire.¹

Continued in 1904 by—

- III. Forfar; and
- IV. Fife.

1903.—Mr. C. E. Moss, of Leeds University, with Mr. W. M. Rankine, dealt similarly with—

- I. Leeds and Halifax; and
- II. Harrogate and Skipton.²

Mr. Moss also wrote a separate paper on 'The Peat Moors of the Pennines',³ and in 1913 he published 'The Vegetation of the Peak District.'⁴

1906.—Marcel Hardy carried out a general Botanical Survey of the Highlands of Scotland, recorded on maps on the scale of 2 miles to 1 inch, copies of which are deposited for reference in 'Outlook Tower,' Edinburgh. His account of this survey was published in the *Scottish Geographical Magazine*.

1911.—Sir Daniel Hall and Sir John Russell published their survey of Kent, Surrey and Sussex.

All these publications are replete with interest, and there are now not a few more which deal with other sections of the country. Each of those which I have seen is the work of one or two observers. Most of these observers have been in a position to devote continuous attention to it. I see, however, no reason why a group of men who concert as to method and record should not carry out such work in successive shorter or longer periods of 'spare-time study.'

To judge by publications, 'vegetation' mapping has made but little progress since the war. The Ecological Society has published many valuable papers, so that, all in all, there is no lack of well-informed guidance available for any local society setting itself to explore the matter with definite relation to its own area. Geologist and entomologist members might take part in the preparation of a particular local study; each would find fresh interests in relating their own particular observations to those of their botanical confrères. A study of this kind might concern quite a small area—even but a single field or wood; it might deal with conditions at different seasons of the year, and if so the meteorological conditions of the year and of the season should be noted; these affect many aspects of the area—not least the life and influence of insects, helpful or harmful.

¹ *Scottish Geographical Magazine*, vol. xvi, 1900; xx, 1904; xxi, 1905.

² *Geographical Journal*, vols. xxi. and xxii., 1903.

³ *Geographical Journal*, 1904, vol. xxiv.

⁴ Cambridge University Press.

⁵ *Scottish Geographical Magazine*, 1906, vol. xxii.

Such considerations as arise in local studies of the types suggested afford examples of the special value that attaches to co-operative records made by groups of observers working on concerted or well-recognised lines.

Maps and Plans.

Not only in studies of the types I have been discussing, but in many other departments of science that come under review here, maps and plans play a part—in some a large part. In many sections of field work it happens that the record of an observation is—to say the least of it—greatly facilitated by the use of a map or by making a rough sketch of a position with well-marked points of reference. Again, a good map can give a great deal of information to one who can read it fully. There are, however, many who understand the map in a general way, but have stopped their understanding of it just short of the point at which they could get from the map all the assistance it can give. The progress in map-reading required for this is really a very small thing. I therefore suggest that it would be worth while for a society to arrange to give guidance in map-reading to any of its members who wish to have it. I can say with confidence that a small measure of help would go a long way to fit a man to mark on the map exactly the point on which he stands, and to read accurately what the map can tell of his immediate surroundings. Once so equipped he could, if he wished, advance rapidly in map work.

With or without such a start I suggest that every active member of a scientific society should *possess* at least one 'quarter sheet' of the '6 inches to a mile' Ordnance Survey Map of a part of his area with which he is familiar. The possession of that single small sheet would be a pleasure, its study on the ground a delight, and the amount of clearness and interest with which it clothed his previous general idea a revelation. I would press upon those who really know maps that they have an opportunity of being real benefactors to others who have only a nodding acquaintance with them, or, let us say, have used them only in an elementary way for motoring.

Records.

I wish to draw attention to the keeping of local society records, and as I have been speaking of maps I may point out that some categories of records ought, as a matter of course, to be registered on the appropriate '6 inches to a mile map.' Of this kind are observations which are or may become of use on any question of precise locality, as for local distribution maps—for instance: botanical maps; old habitations, ruins, foundations, lines of track, and indeed any object of antiquarian interest; local photographic records, noting, in the case of these, the position of the camera and the direction of view—these records should also include local phenomena of interest, whether they are fleeting, recurring or continuing.

I am aware that the importance of such local photographic records is now generally appreciated, but it is left for local societies to make sure that some central list of them is maintained with a set of record copies.

After all, when one speaks of the records of a scientific society, the reference is generally to written and printed records. This reference at once brings on the stage that great bugbear—the cost of printing. This

I am afraid, will long be with us, and we must help ourselves, so far as we can, by cultivating some skill in the writing of summaries. It behoves every contributor to the paper harvest of a society to see to the preparation of a fair summary statement of his paper in as compact a form as possible. Even a brief summary, available for reference, will suffice to bring the work to the knowledge of others working on the same subject or on one for which the investigation detailed may be helpful. It will thus have its chance of bringing together workers who may be mutually helpful.

Preservation of Records.

Whether printed or only recorded in MS., 'minutes' and other filed documents, the records of local scientific societies ought to be scrupulously preserved. It is not always easy to secure the preparation of good records, but these *can* be secured if the secretary or the editor is sufficiently persistent. Some of the difficult members may be landed by the bait of a draft which is obviously—it may be knowingly—inadequate. Once secured, records must be preserved intact.

Preservation of Examples.

The preservation of valuable or interesting specimens is no less important than that of documents. In the case of specimens it is of course desirable to secure their early or ultimate deposit in a permanent institution, where they will be effectively preserved, while continuing to be available for reference or other study. In any event, alike for specimens and for documents, provision for preservation should take account of the possibility of temporary or permanent discontinuance of a society or—and this applies particularly to material examples—death or lapse of care of interested holders.

One case of such lapse of care is worth mentioning as a warning. Many interesting examples of work of prehistoric man had been diligently collected by an able collector resident in an area of special interest in this respect. The owner of the land took much interest in the collection and erected on the margin of a loch which was the centre of the area a delightful, small permanent museum for the preservation and exhibition of the collection. The collector died. The estate was sold, and with it the museum and all it contained. The museum building was put to other uses, and of the objects collected part only were passed to safe custody.

The List of Papers.

We all regret extremely that the publication of the 'List of Papers' prepared under the auspices of the Corresponding Societies Committee has been interrupted. This publication is of very definite national value. It is in effect a general index to a mass of good, honest work by a great body of enthusiastic devotees of science, many of whom have both exceptional opportunities and great ability. Collectively their interests include many diverse subjects of study. In effect they form an army of voluntary workers whose services throughout the field outlined by the Corresponding Societies have a high potential value.

Now what is necessary to secure this value for science? Obviously, first, a record of the additions to knowledge obtained by their work, and secondly, an accessible announcement of that record. This is the minimum of publication required. The *first* of these requirements has to be met locally. For a large proportion of the investigators concerned the local society is the only obvious avenue of publication, and the possibility of publication is a very definite incentive to accuracy of investigation and to definiteness in statement. The *second* requirement cannot be met more effectively than by the continued publication of the 'List of Papers.'

Succinct records in the Reports of Local Societies and clear national lists are both essential. The obstacle in the way in the case of each is the cost of printing. We are doing our best to grapple with it locally; but this is no easy task, and we hope that its difficulty will not be increased. In particular we hope that a way will be found to ward off the threatened charge of income-tax on our Society funds. These are meagre indeed, and so serious a reduction would be practically prohibitive of due publication.

"The Locality" in School Work.

In addressing you from this chair two years ago Sir Daniel Hall made an admirable appeal for the enrichment of the education provided in our schools—Elementary Schools and Grammar Schools. Now, as it has happened, a great part of my work has been concerned with the extension of the use of science as an element in education. Therefore I am fain to hope that you will not grudge me a few minutes to put to you one small suggestion in this connection.

Sir Daniel put in the forefront of his address the value of using as a definite element in the education provided in a school the lessons suggested by a knowledge of its environment. He spoke especially with reference to country schools. Now I believe that both teachers in towns and those in the country *do* recognise this value and aim at using the local environment to good purpose. Many of them have valued highly the suggestions made in that address. We know, however, that subjects of study are numerous, and that among teachers, as among other men and women, tastes differ. Many teachers—schoolmasters and schoolmistresses—have the geographical outlook well developed, and those are no doubt interested and very helpful members of local scientific societies. Obviously, however, there must be many whose personal leanings are not in this direction.

Might not some individual members of our societies make a start in this matter, say, by presenting to a school maps or other things that would help to make instructive those of the elements in the make-up of the locality that are more obvious to young people? Even as a beginning, at any rate, a copy of the 6-inches-to-a-mile quarter sheet, suitably coloured for roads, streams, houses, woods, etc., and with any well-defined slopes indicated by shading. I feel sure that there is many a school where the home map is not now thus exhibited. I believe that such a present would not be declined; and that, with it on the schoolroom wall, the head of the school would soon wish for more. I should like to see in every school and public reading-room *several* local maps representing aspects of the environment bearing on its most marked interests. In thinking out

these, and in taking part in their preparation, active members of local societies would find an attractive sphere of interest.

They would, however, be doing better than that—they would be lending a useful hand in encouraging studies that would inevitably extend interest in ‘natural knowledge’ generally. They would help to increase the number who would find their lives enriched by such studies, and who might in after years become working members of a local scientific society.

The Conference of Delegates of Corresponding Societies met at Leeds on Thursday, September 1, at 2 p.m. The delegates present were forty-four in number, representing fifty-nine societies. Two representatives were also present from Section K (Botany).

The President of the Conference, Sir Francis Ogilvie, C.B., LL.D., delivered an address, which is printed above. Mr. T. Sheppard (Vice-Chairman) proposed a cordial vote of thanks to the President, which was carried by acclamation.

A proposal that the delegates should lunch together before the adjourned session was not adopted. It was recommended, on the motion of Sir George Fordham (Hertfordshire Natural History Society) that agenda of the Conference should be circulated in advance to delegates.

The report of the Corresponding Societies Committee was submitted, dealing with (1) the liability of scientific societies to income-tax, which is the subject of test cases selected by agreement between the British Association, the Society of Antiquaries and the Treasury, and now *sub judice*; (2) the liability of scientific and educational films to import duty, as to which the Treasury is not willing to make any concession; (3) the revision of the Register of Corresponding Societies, which the Council of the British Association had postponed until after the Leeds meeting. Out of a total of 161 societies, only from 35 to 50 have sent delegates to recent Conferences; and in 1923 the Committee recommended to the Council that any society which does not send a delegate to the Conference during five successive years should be deemed, unless there is reason to the contrary, to have ceased to be a Corresponding Society.

Sir George Fordham (Herts N.H.S.) addressed the Conference on the Preservation of British Wild Flowers, and moved ‘that it is desirable that information should be obtained as to the number of Local Government areas in the United Kingdom and the Irish Free State, in which bylaws, relating to the destruction of wild flowers and plants, at present exist; as to the terms of such bylaws; and as to the prosecutions which have taken place thereunder.’ After discussion this recommendation was adopted; but a motion recommending the circulation of a descriptive list of rare plants was rejected, on the ground that such a list would draw undesirable attention to the rarity of such plants, and accelerate their disappearance. A motion proposed by Dr. E. M. Delf (Section K, Botany) was adopted: ‘That it is desirable to approach educational and other public bodies with a view to securing their co-operation in the protection of wild flowers and forest or woodland trees from fire or other damage.’

Prof. E. I. Hawkins (Geologists’ Association) addressed the Conference on the preservation and scientific record of geological sections, of historical

interest, and the protection of natural features, as well as ancient buildings under an amended 'Ancient Monuments Act.' It was explained that the Council of the Association already had this matter under consideration.

At the adjourned meeting on Tuesday, September 6, Mr. T. Sheppard, in the Chair, a letter from the Director of the International Institute of Intellectual Co-operation was read, calling attention to the drawbacks of 'mixed' scientific publications by societies, etc. This letter, which had been referred to the Conference by the Council of the Association, was received without comment. Its discussion led to reference by Sir George Fordham and Dr. C. Tierney to the question of the size of scientific societies' publications, but it was decided that no further action should at present be taken on this matter.

Mr. T. Sheppard, Vice-Chairman of the Corresponding Societies Committee, opened a discussion on Natural Reserves with the following communication :—

Nature Reserves in Yorkshire.

CERTAINLY no county in the British Isles has such an extraordinary variety of scenery and conditions for the preservation of animal and plant life as has the Broad-acred Shire. On the east is the sea coast, with its wealth of cliffs, bays and promontories; immediately to the west are the Cleveland Hills and the Yorkshire Wolds; then the great Central Valley of York, and beyond that the Pennine Chain, with its variety of mountain, mere and marsh. Each of these areas is suitable for bird life in one form or another, and fortunately Yorkshire still possesses broad-minded landowners who are interested in the preservation of our fauna and flora.

In some parts of England we hear much of the fact that certain districts have been set apart as sanctuaries, but in Yorkshire for generations different landowners have given strict instructions that the animals and plants on their properties shall be preserved. Even quite close to Leeds and the centre of the county, where apparently collieries and factories are contaminating the atmosphere, quite a large number of well-wooded districts exist in which the birds, mammals and the wild flowers receive shelter and freedom. While these areas may be looked upon as sanctuaries, they are to a certain extent unofficial, but fortunately Yorkshire possesses on its eastern side three distinct sanctuaries in which the fauna and flora are well represented and at present well preserved. These are Spurn Point, Hornsea Mere, and Flamborough Headland.

The well-known precipitous cliffs of Bempton and Flamborough harbour Guillemots, Razorbills, Puffins, and birds which usually lay one egg on a ledge and hatch the young one therefrom. In the south-east corner of the county is the magnificent sand tract of Spurn Point, where a totally different aspect of sea-bird life, which bring its young up in nests made in holes in the sand, thrives.

Between the two is Hornsea Mere, where the secluded woods and the protection afforded by the landowner entice certain Grebes and other interesting species to breed.

Thus, in the three sanctuaries, quite a large proportion of the important birds of the British Isles may be seen at one time or another.

The Yorkshire Wild Birds and Eggs Protection Committee contributes funds for the payment in each of these areas of watchers who, during the breeding season, do their best to prevent wanton destruction among the birds and their eggs.

Unfortunately, we cannot claim absolute sanctuary for the birds in either of these areas, each of them is visited by trippers and others, who do harm more by thoughtlessness than by mischief; but by the aid of our watchers the damage is considerably lessened.

Spurn Point.

Perhaps the most interesting of the areas is Spurn Point, which has been a bird paradise for a considerable time, possibly aided by the powerful lighthouse, the beams from which attract great quantities of migrating species. The isolated sandbank at

Spurn has produced an enormous number of rare forms at one time or another. Birds arriving in this country in the spring migration, or departing from it in the autumn, assemble at Spurn.

The lighthouse is an attraction—a powerful light at night seems to have a fascination for birds of passage, some even dashing themselves against the glass in their anxiety to get near the light, many being killed in this way. In recent years, however, through the efforts of the Royal Society for the Protection of Birds, the lighthouse has had placed upon it a number of perches upon which the birds can rest.

Unfortunately, during the war, many drastic changes had to be made in this otherwise secluded region, and species which ordinarily bred there in great numbers were disturbed, and in some instances disappeared. However, the district is still one of the few breeding colonies of the beautiful Sea-Swallow, or Lesser Tern, the Ringed Dotterel, and other rare birds, while occasionally the Oyster-Catcher and similar interesting forms are known to nest here.

Formerly, great destruction occurred among the eggs by trippers from Grimsby and other places, who deliberately threw them about or threw stones at them, and in addition harm was done by indiscriminate collectors who gathered the eggs in large numbers for sale. Now the watcher does his best to prevent this destruction, and the eggs are marked with indelible ink, so that they cannot very well be sold.

Probably in no part of England is the question of protective coloration, as applied to both birds and their eggs, so pronounced as on the Spurn Peninsula. I have seen within a small area twenty or thirty different clutches of eggs of the Lesser Tern, and yet a stranger unfamiliar with the eggs would probably not see one; in fact, I have been with parties when members have actually stepped upon the eggs before realising what they were doing. The bird does not make any nest, as usually known, but merely scoops a slight hollow in the sand.

But an even more striking example occurs in the young birds themselves. So soon as they are hatched they resemble little balls of fluff, again spotted and streaked like sand. The last time I was at Spurn I walked along the sands to the Point, and I pointed out a single chick of a Lesser Tern to a friend. This was running about on the sands some distance away, but on a warning note from the parent birds flying above it immediately flattened itself at full length and remained absolutely motionless. My friend could not see it. We walked slowly towards it. I very quietly stooped down and picked the bird up in my hand, it making no attempt to get away. It was, of course, immediately released, and we left it to be joined by its parents.

Quite apart from the ordinary species which one meets with in a place of this character, occasional rare forms arrive, even Flamingoes, Great Bustards and other semi-tropical birds being recorded, and, I much regret to say, frequently have been shot. However, in recent years, there has been a great change among naturalists with regard to our wild birds. Formerly a naturalist was more after the manner of a collector, and delighted in surrounding his walls with all the rare species he could possibly shoot. To-day he takes more interest in watching the birds through a telescope, or in photographing them.

Hornsea Mere.

With the help of the owner of the Mere, and a paid watcher, the interesting species of birds breeding in this vicinity are not showing any decrease. There is a heronry at the Mere, and the herons can often be seen perched on stumps round the water keeping a look-out for the fish upon which they live. The Mere is generally known to ornithologists, however, as the breeding ground of the Great Crested Grebe, a species which only has a few breeding grounds in the British Isles. Other Grebes, various forms of ducks, etc., occur, and the woods surrounding the Mere shelter an enormous number of our most interesting songsters. While water-bird life is common, the birds of prey—the Owls, Hawks, Buzzards, etc.—also are present.

Among the other interesting visitors to Hornsea Mere may be mentioned the Cormorant (a species which for many years nested on the wreck of the *Beaconsfield*, a ship which was stranded off the shore at Aldbrough); Purple Heron, Bittern, Glossy Ibis, Golden Eye, Spotted Crake, Stone Curlew, and others.

Hornsea Mere is the last of many meres and marshes which once existed in East Yorkshire, and doubtless at one time gave it the appearance of the Norfolk Broads, which are so well known for the quantity of birds living there to-day. One of the most beautiful and interesting of the birds of Norfolk is the Bearded Titmouse, a species which builds its nest among the reeds, the male bird having curious dark

patches on the sides of its face, somewhat resembling the old 'Dundreary' whiskers of years ago, hence the name 'bearded' Titmouse.

A few years ago some pairs of these species were brought to Hornsea Mere and let loose among the reeds in the hope that they would establish themselves, and give an added charm to the fauna of the district. From reports which were received it seemed clear that for a year or two they did actually survive and nest around the Mere, but their numbers grew fewer and fewer, and eventually the species disappeared altogether.

The third sanctuary to which I refer is that of the famous

Flamborough Headland.

Standing on the high cliffs at Bempton one can see, to the north Filey, snugly sheltered in Filey Bay, with the treacherous Brig to the right; and on a fine day Scarborough, with its castle-crowned hill, appears on the sky-line beyond Filey cliffs. Immediately to the south are the Flamborough Lighthouse and the cave-worn cliffs; beyond, Bridlington Bay and Bridlington; and in the dim distance can be seen the low cliffs of the interesting district of Holderness. In front is the North Sea, the brilliant blue waters of which are washing the cliff foot, over 400 feet below; in some places the sea never recedes from it. Quite apart from their charming surroundings, the cliffs themselves cannot but strike the visitor with awe and wonder. At Bempton and Speeton they rise in a perpendicular wall: indeed, in some parts are overhanging, to a height of nearly 450 feet. They consist of pure chalk, the brilliant whiteness of which is softened by time, and the whole effect is enhanced by the appearance, here and there, of streaks of green, where vegetation has found a footing.

But apart from the sea, the scenery and the surroundings, the birds of Bempton cliffs are world-famous.

The ledges and crannies on that great wall of rock are crowded with myriads of sea-fowl. These can easily be seen, particularly with the aid of a field-glass, their dark colour contrasting well with the background formed by the chalk. An enormous multitude, row upon row, tier upon tier, can be identified. In addition to those on the ledges, which are occupied in domestic affairs, the air is alive with the croaking and screeching of tens of thousands of them; and the surface of the water deep down below is dotted with floating birds. At times the sound made by this whirl of feathered life is almost deafening.

Here at Flamborough we have one of the principal breeding grounds of sea-fowl in the British Isles; and every visitor to the cliffs must be impressed by the extraordinary profusion of bird life which occurs. The chief occupant is the Guillemot, a quaint bird in brown and white, harlequin fashion; the Razorbill and Puffin also occur in numbers, while more rarely the Kittiwake, Herring Gull and Cormorant can be identified. In recent years the Fulmar Petrel has joined the throng: Kestrels, Carrion Crows and Jackdaws are there also, and, as might be expected, thrive well. Among smaller birds, the Stock Dove, Rock Dove, Pipit, and House Martin share with their larger confrères the hospitality which these cliffs afford.

The Guillemot is unquestionably the main item in the calendar on Flamborough Headland. It arrives on the cliffs in May, and soon after begins to take its place on the ledges and lay its eggs and bring forth its young, finally quitting the neighbourhood about the end of August. Only one egg is laid by each bird, and it is remarkable for being almost the largest egg, in comparison with the size of the bird, that is known, weighing on an average a quarter of a pound, or one-eighth of the weight of the bird. This egg is markedly pear-shaped, and its inability to roll prevents it from falling off the cliffs, being placed, as so many of them are, on exceedingly narrow ledges, many of which slope seawards. But the shape of the egg is of little moment compared with its colouring and decoration. In no other area is such a variety of marking to be met with as in the Guillemots' eggs on Flamborough Headland. They can be obtained in almost every possible shade of green, blue, red, purple, or brown, and they are marked by blotches, streaks, pencillings, or in other ways, to a degree which can only be appreciated by an examination of the specimens themselves. No two eggs are exactly the same, consequently here of all places can the question of variation be investigated. There are definite types of eggs, most of which can be secured at a very small cost. Collectors, however, in order to add uncommon forms to their series, contest for any unusual colouring or marking, and an exceptionally 'good' egg consequently realises a high price.

One collector has made a special point of securing eggs of unusual shapes and sizes, irrespective of their ornament, and in this way has obtained a series, varying in size from a double-yolked Guillemot egg weighing 6 oz. to a small example the size of the egg of a blackbird. In shape he has specimens assuming extraordinary outlines, resembling sausages, bottles, and other unusual forms.

To obtain the eggs it is necessary to climb the cliffs by means of ropes. This is accomplished by gangs of 'climbers,' and their operations are a sight not soon forgotten. There are four or five gangs, consisting of four men each, and a gang restricts its operations to a definite part of the cliffs. The outfit of the climber consists of two stout hemp ropes, two hempen loops or 'breeches,' an iron spike surmounted by a pulley, two linen bags which are hung from the sides of the climber and crossed over to the opposite shoulder, and last, but not least, a good hat, which is stuffed with hay or other padding. This latter item, which formerly took the form of a 'billy-cock,' a superannuated top-hat, or a soldier's helmet, since the war has given place to a 'tin hat,' is a very important item in the 'rig' of a climber, who knows no fear beyond that of falling pieces of chalk, which sometimes are dislodged and drop upon him. Broken Head, a name given to one part of the cliffs, indicates the spot where the padding was not sufficiently effective. Accidents, however, are of exceedingly rare occurrence; in fact, by no means so common as they are in what might be looked upon as much safer occupations.

The method of climbing is as follows:—The climber places his legs through the two loops fastened to the end of a lowering rope, which is inserted in an iron pulley stuck in the ground near the cliff edge. His mates sit on the grass above with their heels firmly implanted in the soil, and with the rope wrapped round them, a broad leather belt preventing the sliding rope from doing harm. The climber backs towards the cliff edge, slides over, and is lowered. A second or guide rope hangs down by means of which he can signal and inform those above whether he wishes to be pulled up or lowered. His hands are filled with grass as a protection from the chafing of the rope, and as he descends or ascends he collects the eggs from the ledges and places them in the bags at his sides, a hooked stick enabling him to reach any awkward positions. The dexterous manner in which the climber can seize the eggs and skip along the ledges is the result of years of practice, and viewed from the cliff top the sight of a mere speck of humanity, swaying to and fro as he throws himself from ledge to ledge, is memorable. In one part, where the cliffs considerably overhang, a steel rope has been secured to the face, by means of which the operator is able to draw himself under until loaded, when he swings back to the perpendicular. When his linen bags are fairly full of eggs a signal is given, one hears the command 'Oop,' and hand over hand the rope is hauled in, until the head of the climber appears over the ledge of the cliff. He is then able to take his weight from the rope and assist himself up the slope. The eggs are placed in a basket, unusually 'pretty' or rarely marked eggs being put on one side, the remainder being sold at twopence or threepence each.

The season commences in the third week in May, and finishes at the end of June, or, at the latest, the first week in July, during which period, according to Mr. E. W. Wade's calculations, each gang collects from 300 to 400 eggs daily, or, allowing for wet weather, an average of 130,000 eggs per season. These are sold to collectors, and are also made use of in other ways. Notwithstanding this enormous draw upon the eggs, there appears to be no diminution in the numbers of the birds; in fact, according to some authorities, they increase annually.

The Peregrine Falcon within recent years made its appearance on these cliffs, selecting its nesting place near Danes' Dyke in 1907 and 1908, and subsequently near Raincliffe (Buckton), where the cliff rises to 436 feet, the highest point of the Flamborough range. It was hoped that this magnificent bird would continue to nest here. It was strictly protected by the Yorkshire Naturalists' Union, but it only remained for a few years.

As a contrast between the conditions which prevailed at Flamborough about a hundred and fifty years ago and those which now obtain, I quote an account of a visit to Flamborough on July 3, 1769. It is extracted from Pennant's 'A Tour in Scotland,' which was printed in Cheshire in 1771. Pennant visited Scotland *via* the East Coast, and called at Flamborough on his way.

'Went to Flamborough Head. The town is on the north side, consists of about one hundred and fifty small houses, entirely inhabited by fishermen, few of whom, as is said, die in their beds, but meet their fate in the element they are conversant in. Put myself under the direction of William Camidge, Cicerone of the place, who

conducted me to a little creek at that time covered with fish, a fleet of cobbles having just put in. Went in one of these little boats to view the Head, coasting it for upwards of two miles. The cliffs are of a tremendous height, and amazing grandeur: beneath are several vast caverns, some closed at one end, others are pervious, formed with a natural arch, giving a romantic passage to the boat, different from that we entered. In some places the rocks are insulated, are of a pyramidical figure, and soar up to a vast height; the bases of most are solid, but in some pierced thro' and arched: the colour of all these rocks is white, from the dung of the innumerable flocks of migratory birds, which quite cover the face of them, filling every little projection, every little hole that will give them leave to rest; multitudes were swimming about, others swarmed in the air, and almost stunned us with the variety of their croaks and screams; I observed amongst them Cormorants, Shags in small flocks, Guillemots, a few black Guillemots very shy and wild, Auks, Puffins, Kittiwakes, and Herring Gulls. Landed at the same place, but before our return to Flamborough, visited Robin Leith's hole, a vast cavern to which there is a narrow passage from the land side; it suddenly rises to a great height, the roof is finely arched, and the bottom is for a long way formed in broad steps, resembling a great, but easy, staircase; the mouth opens to the sea, and gives light to the whole.'

The discussion was continued by Prof. F. W. Oliver, F.R.S., who dealt particularly with nature reserves in East Anglia, and by other speakers.

Votes of thanks to Mr. Sheppard and Prof. Oliver concluded an interesting session.

REFERENCES TO PUBLICATION OF COMMUNICATIONS TO THE SECTIONS

AND OTHER REFERENCES SUPPLIED BY AUTHORS.

The names of readers of papers in the Sections (pp. 314-418), as to which publication notes have been supplied, are given below in alphabetical order under each Section.

References indicated by 'cf.' are to appropriate works quoted by the authors of papers, not to the papers themselves.

General reference may be made to the issues of *Nature* (weekly) during and subsequent to the meeting, in which summaries of the work of the Sections are furnished.

SECTION A.

Aston, Dr. F. W.—Cf. Bakerian Lecture, 'A new Mass-spectrograph of the Whole-number Rule,' *Proc. Roy. Soc. A* **115**, p. 487; 'The Constitution of Ordinary Lead,' *Nature* **120**, p. 224.

Barkla, Prof. C. G.—Cf. series in *Phil. Mag.*, May 1925-Oct. 1927; further papers to appear.

Berwick, Prof. W. E. H.—'The Arithmetic of Quadratic Number-Fields,' to appear in *Math. Gaz.* Cf. 'The Classification of Ideal Numbers that depend on a Cubic Irrationality,' *Proc. London Math. Soc.* ser. 2, **12**, pp. 393-429; *Integral Bases* (Cambridge Univ. Press, 1927).

Davidson, Dr. C. R.—Cf. Greaves and Davidson, 'Preliminary Note on the Determination of Effective Stellar Temperatures,' *Monthly Notices R.A.S.*, Nov. 1925; Greaves, Davidson, and Martin, 'The Relative Effective Temperatures of Twenty-two Stars of early Type,' *ibid.* March 1927.

Heisenberg, Dr. W.—'Ueber den anschentlichen Inhalt der quantentheoretischen Kinematik und Mechanik,' *Zeitsch. f. Physik* **43**, 172 (1927).

Kolhörster, Dr. W.—Cf. *Phys. Zs.* **14**, 1066, 1153 (1913); *Abh. d. Naturf. Gesellschaft zu Halle a.S.*, Neue Folge Nr. 4 (1914); *Verh. d. Dt. Phys. Ges.* **16**, 719 (1914); *Jahrbuch d. Hamb. wiss. Anstalten Beiheft* (1914/5), Seite 323; *Die Naturwissenschaften* **7**, 412 (1919); *Zs. für Phys.* **5**, 107 (1921), **11**, 379 (1922); *Berliner Bericht* **34**, 366 (1923); *Die durchdringende Strahlung in der Atmosphäre* (Hamburg 1924); *Zs. für Instrumentenkunde* **44**, 333, 494 (1924); *Berliner Bericht* **7**, 120 (1925); *Phys. Zs.* **26**, 654 (1925), **27**, 62 (1926); *Die Naturwissenschaften* **14**, 290, 313 (1926); *Zs. für Phys.* **36**, 147 (1926); *Berliner Bericht* **11**, 92 (1927); *Zs. für Phys.* **44**, 754 (1927).

Menzies, A.—Probably to be dealt with in *Proc. Roy. Soc.*

Milne, Prof. W. P.—Cf. 'Sextactic Cones and Tritangent Planes of the same System of a Quadri-cubic Curve,' *Proc. London Math. Soc.* ser. 2, **21**, pt. 5; 'The Tritangent Planes of the same System of the Curve of Intersection of a Cubic Surface and a Quadric Cone,' *ibid.* **25**, pt. 3; 'The 7-tangent Quadrics of the same System of the C_5^2 ,' *ibid.* **26**, pt. 2; 'The 5-tangent Conics of the Plane Quintic Curve,' *J. London Math. Soc.* **2**, pt. 2.

Nolan, Prof. J. J.—Cf. Nolan, R. K. Brylan, and G. P. de Lachy, in *Proc. Roy. Irish Acad.* **37**, p. 1 (1925); Nolan and de Lachy, *ibid.* **37**, p. 71 (1927).

Turnbull, Dr. H. W.—Offered to *Math. Gaz.* Cf. 'On differentiating a Matrix,' *Proc. Edinburgh Math. Soc.* ser. 2, **1** (1927-8); 'The Matrix Square and Cube Roots of Unity,' *Journ. London. Math. Soc.* **2** (1927).

Wilson, B. M.—Cf. *Collected Papers of Srinivasa Ramanujan*, ed. G. H. Hardy, P. V. Seshu Aiyar, and B. M. Wilson (Cambridge Univ. Press, shortly).

SECTION B.

Dawson, Prof. H. M.—*Chemistry and Industry*, 1927, p. 897. Cf. 'Acid and Salt Effects in Catalysed Reactions,' by H. M. Dawson and J. S. Carter, *Journ. Chem. Soc.*,

1926, 2282; 'The Minimum Reaction Velocities for Acid-salt Mixtures,' by H. M. Dawson and N. C. Dean, *Journ. Chem. Soc.*, 1926, 2872; 'Dependence of the Characteristics of the Minimum-velocity Mixture on the Concentration of the Acid and the Application of Minimum Velocity to the Determination of Catalytic and Ionisation Constants,' by H. M. Dawson and C. R. Hoskins, *Journ. Chem. Soc.*, 1926, 3166; 'Derivation of a General Equation for the Catalytic Activity of Acids: the General Catalytic Catenary,' by H. M. Dawson, *Journ. Chem. Soc.*, 1927, 213; 'Isohydric Solutions and the Velocity of Chemical Change,' by H. M. Dawson and C. R. Hoskins, *Proc. Leeds Phil. Soc.*, 1926, 1, 108; 'The Early Stages of an Autocatalysed Reaction: Generalised form of the simple Autocatalytic Catenary,' by H. M. Dawson, *Journ. Chem. Soc.*, 1927, 458; 'The Tridimensional Co-ordination of Catalytic Variables: Relations between the Data for pure Acids and the corresponding Minimum-velocity Mixtures,' by H. M. Dawson, *Journ. Chem. Soc.*, 1927, 756; 'The Determination of Hydrolytic Velocity Coefficients from Isocatalytic Data: Reaction Velocities in Buffer Solutions and Compound Catalytic Catenaries,' by H. M. Dawson, *Journ. Chem. Soc.*, 1927, 1146; 'A General Kinetic Method for the Determination of the degree of Dissociation of Water,' by H. M. Dawson, *Journ. Chem. Soc.*, 1927, 1290; 'The Significance of Iso-Catalytic Data and the so-called Proton Theory of Chemical Reactivity,' by H. M. Dawson, *Journ. Physical Chemistry*, 1927, 31, 1400; 'The Hydrolysis of Ethyl Acetate with Acetic Acid as Catalyst,' by H. M. Dawson and W. Lowson, *Journ. Chem. Soc.*, 1927, 2107.

Read, Prof. J.—*Journ. Soc. Chem. Ind.* 46, no. 39.

Wardlaw, Dr. W.—Cf. Wardlaw and Wormall, *Journ. Chem. Soc.* (1927), 130, 1087; Bucknall, Carter and Wardlaw, *ibid.* (1927), 512; James and Wardlaw, *ibid.* (1927), 2145.

Wightman, W. A.—Cf. *Journ. Chem. Soc.* (1925), p. 1421; (1926), p. 2541.

SECTION C.

Davison, E. H. (Cornish Granites and Tin Lodes).—*Trans. Roy. Geol. Soc. Cornwall* 15, pt. viii, p. 576.

Davison, E. H. (Cornish Pegmatites).—*Geol. Mag.*, May 1924, pp. 225-7.

Slater, Dr. G.—Cf. following papers which form connected series under general title of the first: 'Glacial tectonics as reflected in disturbed drift deposits,' *Proc. Geol. Assoc.* 37, pp. 392-400 (1926); 'The structure of the disturbed deposits in the lower part of the Gipping valley near Ipswich,' *ibid.* 38, pp. 157-182 (1927); 'The structure of the disturbed deposits of the Hadleigh Road area, Ipswich,' *ibid.* 38, pp. 183-216 (1927); 'Glacial observations in the Wallasey district,' *Proc. Liverpool Geol. Soc.* 14, pp. 143-157 (1925); 'A new section in the upper drift deposits of Toronto,' *Trans. Roy. Soc. Canada*, sec. iv (1927); 'The structure of the disturbed deposits of Möens Klint, Denmark,' *Trans. Roy. Soc. Edin.* 55, pt. ii, no. 12 (1927); 'The disturbed glacial deposits in the neighbourhood of Lönstrup, near Hjörring, north Denmark,' *ibid.* no. 13 (1927); 'The structure of the Mud Buttes of Alberta, Canada,' *Bul. Geol. Soc. Am.* pt. iv (1927); 'The structure of the drumlins on the south shore of Lake Ontario, Canada,' *Bul. N.Y. State Museum* (1927); 'Observations on the Nordenskiöld and neighbouring glaciers of Spitsbergen (Oxford U. Exped. to S., 1921), *Journ. of Geol.* 33, no. 4 (1925).

Trueman, Dr. A. E.—Probably to be published in *Proc. S. Wales Inst. Engineers*. Cf. J. H. Davies and Trueman, 'A Revision of the non-marine Lamellibranchs of the Coal Measures, and a Discussion of their Zonal Sequence,' *Q.J. Geol. Soc.* 83, pt. ii, pp. 244, 259 (1927).

Tyrrell, Dr. G. W., and B. H. Barrett.—To appear in *Trans. Glasgow Geol. Soc.*

SECTION D.

Bruce, J. R.—To appear in *Journ. Marine Biol. Assoc.*

Cutler, D. Ward.—To be published in *Journ. Exper. Biol.* 3, no. 2.

Grove, Dr. A. J.—To appear in *Q. Journ. Microsc. Sci.*

- Manton, Miss S. M.—To appear in *Phil. Trans. Roy. Soc. B.*
- Pantin, C. F. A.—Cf. 'On the physiology of amoeboid movement,' in *Journ. Marine Biol. Assoc.* **13**, 1 (1923); *Brit. Journ. Exper. Biol.* **1** (1924), **3** (1926); further work to be published in *B.J.E.B.*
- Ridley, H. N.—Cf. (on the voices of apes) *Illustrated London News*, Sept. 17.
- Taylor, J. W.—Cf. 'The Geographical Distribution of Mollusca,' *Monograph of British Land and Freshwater Mollusca of the British Isles* **1**, pt. 7 (Aug. 1900); 'Dominancy in Nature,' *Trans. Yorks. Nat. H.*, 1913, pp. 1-40; 'Geographical Distribution and Dominance in relation to Evolution and Phylogeny,' *Trans. Second Entomol. Congress*, 1912, pp. 271-294; also *Journ. Conchology*, passim.
- Wells, G. P.—To be included in paper for *Brit. Journ. Exper. Biol.*

SECTION E.

- Fordham, Sir G.—To appear in *Geog. Journ.*
- Garnett, Miss A.—To appear in *Scot. Geog. Mag.*
- Harris, Miss S.—For section of paper dealing with Alderney, see *Sociol. Rev.*, Oct. 1926, pp. 265-278; to appear more fully in *Rep. and Trans. Soc. Guernesaise.*
- Nathan, Sir M.—To be published in *Geog. Journ.* Cf. presidential addresses, 1923-25, to Roy. Geog. Soc. of Australasia (Queensland branch).
- Reynolds, J. H.—Cf. 'Iceland in 1872 and 1926,' *Geog. Journ.*, July 1927.

SECTION F.

- Florence, P. Sargant.—To appear in *Archiv für Sozial-Politik* (Bonn). Cf. *Economics and Human Behaviour* (Kegan Paul, 1927).
- Yarrow, Sir A.—*The Times*, Sept. 6.

SECTION G.

- Bulleid, Prof. C. H.—Expected to appear in *Engineering*. Cf. *ibid.*, Oct. 1, 1926.
- Burness, H. H.—To appear in *Engineering*.
- Clothier, H. W.—*Electrical Review*, Sept. 9, 16; *Engineering*, Oct. 7. Cf. 'The Design of Electrical Plant, Control Gear, and Connections for Protection against Shock, Fire, and Faults,' *Journ. Inst. Elec. Eng.* **63**, nos. 341, 346 (1925); 'L'Appareillage Cuirasse et l'Elimination des Defauts d'Isolement du Reseau,' *Report Paris High-tension Conf.*, 1925.
- Cobb, Prof. J. W.—*Engineering*, Sept. 9, and elsewhere. Cf. Gas Research Fellowship reports, 1925-6-7, and Reports of Joint Gas Research Sub-committee of Univ. of Leeds and Inst. Gas Engineers, 1926-27, in *Trans. Inst. Gas Eng.*
- Cramp, Prof. W.—*Engineering*, Sept. 2, 9.
- David, Prof. W. T.—*Engineering*, Sept. 16.
- Dunsheath, P.—*Engineering*, Oct. 14. Cf. 'Dielectric Problems in High-voltage Cables,' *Journ. Inst. Elec. Eng.* **64**, p. 97 (1926); '33 KV. Cables with metal-sheathed Cores, with special reference to the S.L. Type,' *ibid.* **65**, p. 469 (1927).
- Gilchrist, J.—To appear in *Engineering*.
- Hartmann, J.—*Engineering*, Sept. 9, 16. Cf. *Nye Ensrettere og periodiske Afbrydere* (Gjellerup, Copenhagen, 1918).
- Lander, Dr. C. H.—*Engineering*, Sept. 9.
- Lupton, H. R., and J. H. W. Gill.—*Water and Water Engineering*, Oct. 1927. Cf. Gill-'*Helivane*' and *Helivane Pumps*, Hathorn Davey & Co., Leeds; Patent specifications 268037, 210841, 163178, 142713, 140985, 257111.
- Matthews, R. Borlase.—*Engineering*, Sept. 16; *Electro-Farming Journ.*, Nov. 1927.

- Murgatroyd, F.—*The Electrician*, Sept. 16; *Electrical Review*, Sept. 30; to be published in full in *Engineering*.
- Naylor, T. M.—*Engineering*, Oct. 7. Cf. 'Whirling and Vibrating Speeds of Loaded and Unloaded Shafts,' *Inst. Civ. Eng.* selected engineering papers, no. 36.
- Stanton, Dr. T. E.—*Engineering*, Sept. 2.
- Swift, H. W.—*Engineering*, Sept. 30.
- Turner, F. C.—*Engineering*, Sept. 16; to be published in full in the same.
- Wheeler, R. V.—*Engineering*, Sept. 9. Cf. *Journ. Chem. Soc.* **97**, 1917; **99**, 649; **105**, 131; **109**, 707; **121**, 2345; **127**, 1412, 2236; (1926) 1410; (1927) 700.

SECTION H.

- Ashby, Dr. T.—Cf. Ashby, *Roman Campagna in Classical Times*; further material to appear in Platner & Ashby, *Topographical Dictionary of Ancient Rome* (Oxford, 1928), and intended to appear in *Bulletino Comunale* (Rome, 1928).
- Bryce, Prof. T. H. (On Bones from the North of Scotland).—Cf. *Proc. Soc. Antiq. Scot.* **60** (1925-26), **61** (1926-27).
- Carline, G. R.—To form basis of a forthcoming issue of *Bankfield Museum Notes*.
- Cunnington, Mrs.—*Wiltshire Gaz.*, Sept. 8; *Antiquity*, Mar. 1927, p. 92.
- Daniel, J. E.—*Man*, Oct. 1927.
- Fisher, Dr. R. A.—Intended for publication by Roy. Soc.
- Frankfort, Dr. H.—To be published in *The Antiquaries' Journal*, April, 1928. Cf. 'Studies in Early Pottery of the Near East: Pt. I, Mesopotamia, Syria, and Egypt and their earliest Interrelations' (1924); 'Pt. II, Asia, Europe, and the Aegean and their earliest Interrelations' (1927), *Roy. Anthropol. Inst. Occas. Papers* 6 and 8.
- Hutton, J. H.—Expected to appear in *Journ. Roy. Anthropol. Inst.* Cf. J. P. Miles, *The Ao Nagas*, note 3, p. 200, and note 2, p. 225.
- Mumford, Dr. A. A.—See *Healthy Growth* (Oxf. Univ. Press, 1927).
- Watman, E. K.—Cf. *Proc. Univ. Bristol Spelaeol. Soc.* **2**, iii; **3**, 1.

SECTION I.

- Bond, C. J.—*Brit. Med. Journ.*, Oct. 8.
- Cramer, Dr. W.—*The Lancet*, Oct. 8, p. 774.
- Dawson, Dr. E. R.—To be incorporated in paper by Dawson and Platt for submission to *Journ. General Physiol.*
- Edridge-Green, Dr. F. W.—*Colour-Blindness and Colour Perception, 1891-1909. Physiology of Vision* (Bell & Sons), 1920.
- Hirst, Miss M., and Dr. C. G. Imrie.—Cf. 'Nitrogenous Metabolism in Post-Encephalitis Rigidity,' *Journ. Physiol.* **62**, i (1926); also *Q. Journ. Med.*, Oct. 1927.
- McLeod, Prof. J. W.—Part expected to appear in *Journ. Pathol. and Bact.* Cf. McLeod and Gordon in *Biochem. Journ.* **16**, p. 499 (1922); *Journ. Pathol. and Bact.* **26**, p. 322 (1923), **28**, p. 155 (1925).
- Platt, B. S.—To be submitted to *Biochem. Journ.* (E. Phillis and Platt). Cf. Platt and Dawson, 'Factors influencing the action of Pancreatic Lipase,' *Biochem. Journ.* **19**, p. 860 (1925).
- Raper, Prof. H. S. (and Miss C. E. M. Pugh).—To appear in *Biochem. Journ.*
- Roaf, Prof. H. E.—To appear in *Journ. Exper. Physiol.*
- Wadge, Miss W. J.—Expected to appear in *Journ. Physiol.*
- Wayne, Dr. E. J.—To appear, under authorship of H. S. Raper and Wayne, in *Biochem. Journ.*
- Wormall, Dr. A.—Cf. papers by Wormall, Whitehead, and Gordon, in *Journ. Immunol.* **10**, 587 (1925), **13**, 439, 451 (1927); *Biochem. Journ.* **19**, 618 (1925), **20**, 1028, 1036, 1044 (1926).

SECTION J.

Bartlett, R. J.—Probably to appear in *Brit. Journ. Psychol.* Cf. 'Does the Psychogalvanic Phenomenon indicate Evition,' *Brit. Journ. Psychol.* **18**, pt. 1 (July 1927).

Drever, Dr. J.—To appear in *Brit. Journ. Philosoph. Studies.*

Farmer, E.—*Journ. Nat. Inst. Indust. Psychol.* **3**, no. 8 (Oct. 1927).

Lowery, H.—Cf. 'Cadence and Phrase Tests in Music,' *Brit. Journ. Psychol.* **17**, pt. ii, Oct. 1926.

MacTaggart, Miss M. M.—Cf. 'Non-scholastic Tests for Backward Pupils,' *Forum of Education*, June 1927.

Mitchell, Dr. T. W.—To appear in *Hibbert Journ.* Cf. Presidential Address, *Proc. Soc. Psychological Res.* **33**, part lxxxv.

SECTION K.

Bower, Prof. F. O.—To be incorporated in chap. xlii, *Ferns*, vol. III, expected to appear in 1928.

Brooks, F. T.—To appear in *New Phytologist* early in 1928.

Foster, Dr. A. S.—Thesis for doctorate, Harvard Univ. library.

Fritsch, Prof. F. E.—Probably to appear in *Ann. Bot.* Cf. 'Contributions to our Knowledge of the Freshwater Algae of Africa,' no. 7, *Trans. Roy. Soc. S. Af.*, 1928.

Gwynne-Vaughan, Dame H. C. I., and Mrs. H. S. Williamson.—Cf. 'Germination in *Lachnea cretea*,' *Ann. Bot.* **41**, p. 489.

Harris, T. M.—Expected to appear in *Meddelelser om Grönland* (Copenhagen); cf. *ibid.* **68** (1926).

Holden, Dr. H. S.—Intended for submission to *New Phytologist*.

Lotsy, Dr. J. P.—Material to be published as supplementary volumes to *Journ. Genetica* (Martinus Nijhoff, The Hague).

Mathias, W. T.—*Pubns. Hartley Botan. Lab. Liverpool*, no. v (Nov. 1927).

Smith, A. Malins.—Expected to appear in *Journ. Linnean Soc.* Cf. 'New Yorkshire Algae,' *Naturalist* (1927).

Stirling, J.—*Pubns. Hartley Botan. Lab. Liverpool*, no. v (Nov. 1927).

Thompson, Prof. J. McL.—*Pubns. Hartley Botan. Lab. Liverpool*, no. iv (Nov. 1927).

Walton, J.—Cf. 'Carboniferous Bryophyta,' *Ann. Bot.* **39** (July 1925); Do., II, to be submitted to the same.

Westbrook, Miss A.—Cf. Delf, Ritson, and Westbrook, 'The Effects of Radiations from a Quartz Mercury Vapour Lamp on Plants,' *Journ. Exper. Biol.*, Dec. 1927.

SUB-SECTION K* (FORESTRY).

Brooks, Dr. C. E. P.—To appear in *Empire Forestry Journ.*; full summary in *Water and Water Engineering*, Sept. 20.

Chipp, Dr. T. F.—Expected to appear in *Timber Trades Journ.*

Clutterbuck, Sir P.—*Empire Forestry Journ.* **6**, pt. ii (1927).

Dallimore, W.—To appear in *Empire Forestry Journ.*

Mukerji, S. K.—To appear in *Empire Forestry Journ.* early in 1928.

Pearson, R. S.—*Timber Trades Journ.*, Sept. 3, p. 695.

Robinson, G. W.—Expected to appear in *Empire Forestry Journ.*

Sutherland, J.—To appear in *Trans. Roy. Scot. Arboric. Soc.* Cf. *Rep. Brit. Assoc.* 1921, p. 451.

Turrill, W. B.—To be incorporated in *The Phytogeography of the Balkan Peninsula* (Oxf. Univ. Press).

SECTION L.

Arnold, J. H.—*Education*, Sept. 23. Cf. *Reforms needed in First School Examinations* (Inc. Assoc. of Asst. Masters in Secondary Schools, Jan. 1927); correspondence in *Journ. of Education*, July-Sept. 1927.

Discussion on Education in Tropical Africa.—See, generally, *West Africa*, Sept. 10, 1927; for Major Church's paper, *East Africa*, Sept. 15, &c.

Schofield, H.—To appear in *Education*.

Watts, E.—*Education*, Sept. 23.

SECTION M.

Fisher, Dr. R. A.—Cf. 'The Arrangement of Field Experiments,' *Journ. Min. Agric.* 33, pp. 503-513.

McMillan, J. A.—To be published as a bulletin of Dept. of Agriculture, Univ. of Leeds.

Sebelien, Prof. J.—Part to appear in *Journ. Min. Agric.*; see also *Norsk Landmandsblad*, Oslo, Sept. 9, 16.

Taylor, T. H.—*Bulletin Agric. Dept. Leeds Univ.*, to be published. Cf. J. Strachan and T. H. Taylor, 'Potato Eelworm,' *Journ. Min. Agric.*, Jan. 1926.

PAPERS GIVEN AT SPECIAL SESSIONS ON TEXTILES.

These were published in special issue of *Journal of the Textile Institute*, Manchester, Sept. 1927.

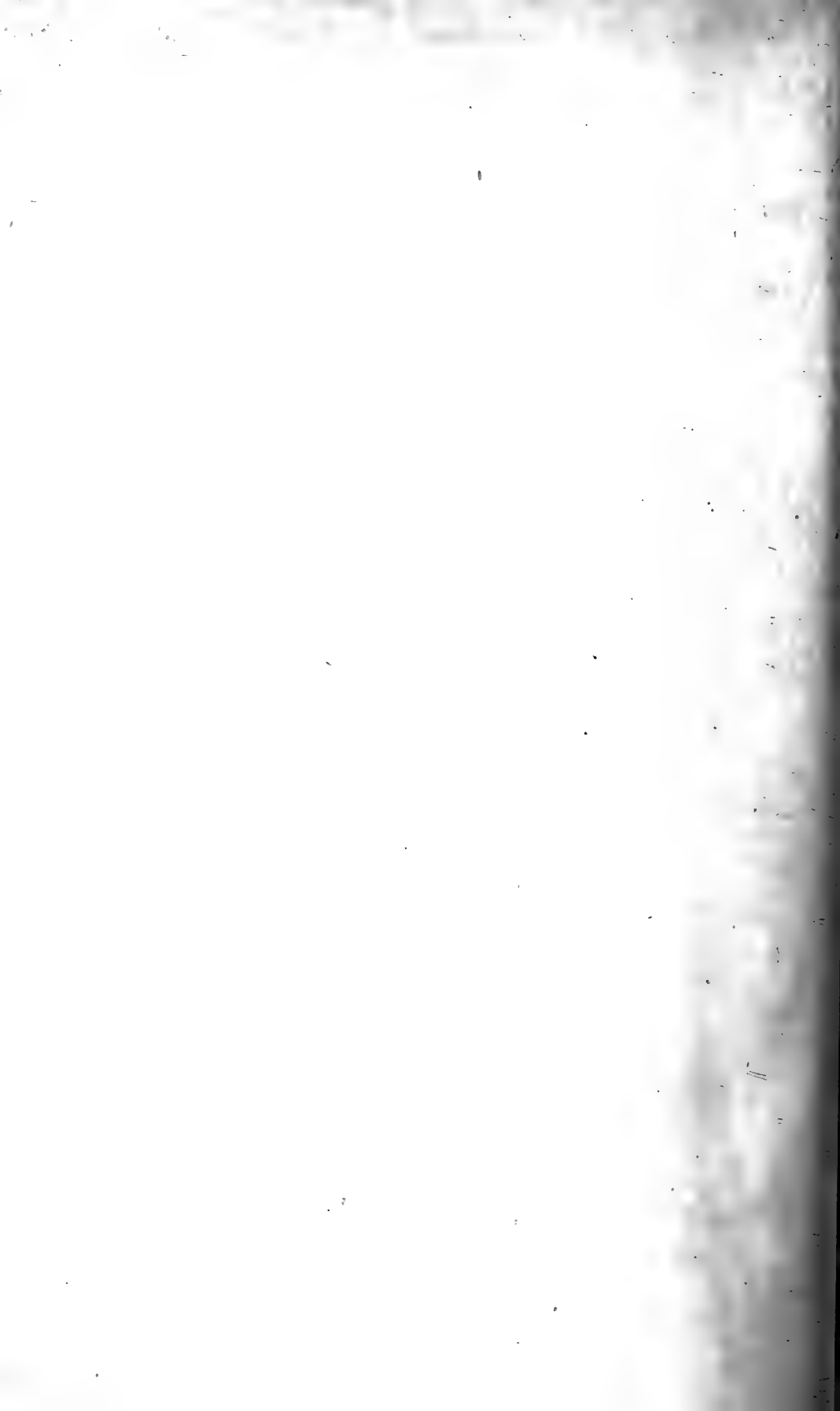

INDEX.

References to addresses, reports, and papers printed in extended form are given in italics.

** Indicates that the title only of a communication is given.*

When two references to a paper are given, the second is to a note of its publication elsewhere, or to a note of other publications by the author on the same subject.

- Acid catalysis, . . . , by Prof. H. M. Dawson, 318*, 430.
- Action of potassium on contractile tissues, by G. P. Wells, 335, 432.
- Address by the President, Sir A. Keith, 1. Agriculture and national education, by C. G. T. Morison, 202.*
- 'Air conditioning' experiments . . . , by Dr. E. Griffiths, 418, 435.
- AIREY, Dr. J. R., *on mathematical tables*, 220.
- ALCOCK, Mrs. N. L., *on control of plant diseases*, 381.
- Algæ of a bog . . . , by A. Malins Smith, 380, 434.
- AMI, Dr. H. M., *Recent discoveries at Combe Capelle*, 358.
- Analytical method in the theory of numbers, by A. E. Ingham, 316.
- Ancient metallurgy in Burma, by H. L. Chhibber, 330*.
- ANDRADE, Prof. E. N. da C., *Molecular theory of liquid viscosity*, 315*.
- Anthropometric instrument, *Demonstration of . . .*, by Prof. H. J. Fleure and Miss R. M. Fleming, 361*.
- Apparatus for oxygen and CO₂ administration, by Dr. H. W. Davies, 371*.
- Apparatus for regulating pH of solutions for smooth muscle experiments, by Prof. B. A. McSwiney and Dr. Berenbloom, 371*.
- Appendicularians, *Origin of*, by Prof. W. Garstang, 331*.
- Appreciation of wit, by Dr. Ll. Wynn-Jones, 373.
- Arable dairy farming, by J. Strachan, 404*.
- Arctic Alpine Bryophyte associations in Britain . . . , by C. V. B. Marquand, 390*.
- Arithmetic of cubic number-fields, by Prof. W. E. H. Berwick, 315, 430.
- ARNOLD, J. H., *First school examinations in secondary schools*, 403, 435.
- ASHBY, A. W., *Economic situation of agriculture*, 346*.
- ASHBY, Dr. T., *Roman roads in the valley of the Tiber*, 358, 433.
- ASHTON, T. S., *Coalminers of the 18th century*, 343.
- ASTLEY, Rev. H. J. D., *Cup and ring markings*, 358.
- ASTON, Dr. F. W., *New mass spectrograph and the whole number rule*, 315*, 430.
- ATHOLL, Duchess of, *Broadening of the outlook in education*, 191.
- Backwardness, . . . , by Miss M. M. MacTaggart, 376, 434.
- Backwardness in arithmetic, by Miss E. Wheeler, 372.
- BALLARD, Dr. P. B., *Art of examining children*, 402.
- BANTA, A. M., and L. A. BROWN, *Sex in Cladocera . . .*, 334.
- BARBOUR, Prof. G. B., *Tertiary and Quaternary history of North China*, 325.
- BARKER, Prof. A. F., *Race and environment as affecting type of sheep and wool supplies of the world*, 414, 435.
- BARKER, Dr. S. G., *Fading of dye-stuffs*, 411, 435.
- BARKER, W. H., *on geography teaching*, 299.
- BARKLA, Prof. C. G., *Coherence of X-rays and the J phenomenon*, 315*, 430.
- BARNES, B., *Cultural varieties of fungi . . .*, 388.
- BARNETT, R., *Geological sections in Sladen valley*, 329.
- BARR, Dr., and Miss HADFIELD, *Nature of action of sunlight on cotton*, 417*, 435.
- BARR, S., *Internal rust spot*, 406*.
- BARTLETT, R. J., *Feeling and psychogalvanic reflex*, 374, 434.
- BATHER, Dr. F. A., *on zoological bibliography and publication*, 284.
- BEAVEN, Dr. E. S., *on plot technique*, 410.

- BERWICK, Prof. W. E. H., Arithmetic of cubic number-fields, 315, 430.
- BEST, Dr. S. E. J., Wheat cultivation in relation to soil types on the Yorkshire Wolds, 342.
- BIDDER, Dr. G. P., *Ancient history of sponges and animals*, 58.
- Biological measurements, Report of Committee on*, 286.
- Biology in the school curriculum, by Prof. R. D. Laurie, 335.
- Bionomics and affinities of Archipolypoda, by Rev. Dr. Brade-Birks, 323.
- BISAT, W. S., Correlation of carboniferous beds of Western Europe, 318.
- *Episodes in the 'Millstone Grit' period*, 319.
- *Junction of 'upper' and 'lower' carboniferous strata*, 319.
- BLACKMAN, Miss W. S., *Modern Egyptian medicine man*, 362*.
- Body measurements, respiratory tests, and school progress, by Dr. A. A. Mumford, 361, 433.
- BOND, C. J., Effect of certain radiated lipoids . . ., 368, 433.
- BORTHWICK, Dr. A. W., Forestry in relation to water catchment areas, 393*.
- BOSWELL, Prof. P. G. H., Cleavage-fan in Ludlow rocks of Denbighshire moors and Clwydian range, 320.
- *Source of constituents of Lower Greensand and other Aptian sediments*, 323.
- BOWEN, E. G., Interpretative map of Dr. Bryn's anthropological observations in mid-Norway, 366.
- BOWER, Prof. F. O., Evolutionary changes in the superficial sorus, 384, 434.
- BRADÉ-BIRKS, Rev. Dr., Bionomics and affinities of Archipolypoda, 323.
- *British Diplopoda and Chilopoda*, 337.
- BRADY, R. P., Rural settlements in the middle Trent valley, 343.
- BRIERLEY, Dr. W. B., on control of plant diseases, 382.
- British Diplopoda and Chilopoda, by Rev. Dr. Brade-Birks, 337.
- British forest policy, by R. L. Robinson, 393, 434.
- Broadening of the outlook in education*, by the Duchess of Atholl, 191.
- BRODETSKY, Prof. S., Equations of the gravitational field . . ., 315.
- BROOKS, C. E. P., Influence of forests on rainfall, 392, 434.
- BROOKS, F. T., Disease resistance in plants, 390*, 434.
- BROWN, D., and Dr. E. F. BRETT, Secondary emission from metallic and metallic oxide targets, 315*.
- BROWN, Dr. R. N. RUDMOSE, *Some problems of polar geography*, 75.
- BROWN, Dr. W., *Mental unity and mental dissociation*, 167.
- BROWNE, C. E., *on educational training for overseas life*, 309.
- BRUCE, J. R., Physical factors on the sandy beach, 331, 431.
- BRYCE, Prof. T. H., Prehistory of Scotland . . ., 364, 433.
- *Human skeletons from the north of Scotland . . .*, 360, 433.
- BUCHANAN, Dr. D. N., Psychological effects of flickering light, 374*.
- BURNES, H., Large low head conduits, 355*, 432.
- BURSTALL, Miss S., *Education of the African woman*, 397.
- BUTLER, Dr. J. A. V., Effect of Electric field on adsorption of ions and neutral molecules . . ., 318*.
- CAMERON, Prof. A. E., Experimental removal of Graber's organ in Tabanid fly larvae, 331.
- CAMPION, G. G., Organic growth of the concept . . ., 379*.
- Canadian land-locked salmon, by Prof. E. E. Prince, 337*.
- CANVEY, E. E., Cotton-growing policy . . ., 416, 435.
- Carboniferous succession in central Pennine area . . ., by D. A. Wray, 329.
- CARLINE, G. R., Primitive Weaving at Bankfield Museum, 363, 433.
- Carpel, Discussion on the, 383.
- CARPENTER, Dr. KATHLEEN E., Survival of some ice-age relics in freshwater fauna of Cardiganshire, 336.
- Castleford, by E. Hepworth, 340.
- CAVE, C. J. P., *on upper atmosphere*, 255.
- Chemical aspect of wool research, by A. T. King, 411, 435.
- Chemistry of coal, by Prof. R. V. Wheeler, 349, 433.
- CHIBBER, H. L., Ancient metallurgy in Burma, 330*.
- *Lampophyres and associated rocks of Mokpalin, Burma*, 330*.
- *Volcanic rocks of Irrawaddy delta*, 330*.
- CHIPP, Dr. T. F., Forestry in relation to climate and erosion, 392, 434.
- CHURCH, Major A. G., on education in tropical Africa, 397, 435.
- Circulation rate, Discussion on, 369*.
- Classification of the colour-blind, by Dr. F. W. Edridge-Green, 374.
- CLAY, Dr. R. C. C., Overlap of the bronze and iron ages, 364.

- Cleavage-fan in Ludlow rocks of Denbighshire moors and Clwydian range, by Prof. P. G. H. Boswell, 320.
- Climates of the past, Discussion on, 386.
- Close voltage rectifier, by F. C. Turner, 352, 433.
- CLOTHIER, H. W., Switchgear for alternating current, 351, 432.
- CLUTTERBUCK, Sir P., Forestry and the Empire, 393, 434.
- Coalminers of the 18th century, by T. S. Ashton, 343.
- Coal supplies and their utilisation, Our available, by Dr. C. H. Lander, 348*, 432.
- Coal supplies, Utilisation of our, by Prof. J. W. Cobb, 348, 432.
- COBB, Prof. J. W., Utilisation of our coal supplies, 348, 432.
- Cochlea, Model of, by G. Wilkinson, 371*.
- Coherence of X-rays and the J phenomenon, by Prof. C. G. Barkla, 315*, 430.
- COLLINGWOOD, R. G., Roman signal stations on the Yorkshire coast, 356.
- COLLINS, DR. MARY, *University course in experimental psychology*, 308.
- Colloidal particles, Discussion on structure and formation of, 317.
- Colonisation and development in East Greenland, by J. M. Wordie, 338.
- Colour-blindness, First recorded cases of, by Dr. F. W. Edridge-Green, 370, 433.
- Coloured fibres in the fleece, by J. E. Nichols, 413, 435.
- Colour Vision, Report of Committee on*, 307.
- Combe Capelle, Recent discoveries at, by Dr. H. M. Ami, 358.
- COMBER, Prof. N. M., on soil surveys, 408.
- Teaching and research work on soil chemistry, 406*.
- Comparative reliability of intuitive judgments of men and women, by Prof. C. W. Valentine, 379*.
- Complement, Some properties of, by A. Wormald, 371, 433.
- Conference of Delegates, Report of, 419.
- Continuation of Prof. Arthur Thomson's and Mr. Dudley Buxton's 'Studies of nasal indices in connection with climate' for Africa, by A. Davies, 366.
- Control of plant diseases, Discussion on, 381.
- Co-ordination compounds*, by Dr. N. V. Sidgwick, 27.
- Co-ordination compounds, Dr. S. Sugden on, 316.
- Co-ordination compounds of molybdenum, by Dr. W. Wardlaw, 318*, 431.
- CORNISH, DR. VAUGHAN, Fixing of linguistic boundaries by national adoption of Christianity . . . , 338.
- Cornish pegmatites, by E. H. Davison, 327, 431.
- Correlation of carboniferous beds of Western Europe, by W. S. Bisat, 318.
- Cotton-growing policy . . . , by E. E. Canney, 416, 435.
- CRAMER, Dr. W., Requirements of the population in milk-fat . . . , 369*, 433.
- CRAMP, Prof. W., Hydraulic model illustrating behaviour of the arc, 347, 432.
- Creatine, Some observations on excretion of, by Miss M. Hirst and Dr. C. G. Imrie, 369*, 433.
- CREW, Dr. F. A. E., *on vasoligation, etc.*, 281.
- Studies on the thyroid, 335.
- CROFTS, Dr. J. M., First and second School Certificate Examinations . . . , 402.
- Cultural varieties of fungi . . . , by B. Barnes, 388.
- CUNNINGHAM, J. T., *on vasoligation, etc.*, 281.
- CUNNINGTON, MIS. M. E., 'Woodhenge', 364, 433.
- Cup and ring markings, by Rev. H. J. D. Astley, 358.
- CUTLER, D. WARD, and L. M. CRUMP, Effect of food-supply on multiplication of protozoa, 335, 431.
- Cytology and development of *Asparagopsis armata*, by Prof. N. E. Svedelius, 380.
- Cytology of Callithamnion, by W. T. Mathias, 380, 434.
- DALLIMORE, W., Minor forest products, 391, 434.
- DANIELL, J. E., Distribution of religious denominations in Wales . . . , 366, 433.
- Darwin's theory of man's descent as it stands to-day*, by Sir A. Keith, 1.
- DAVID, Prof. W. T., Efficiency of internal combustion engines, 353, 432.
- DAVIDSON, Dr. C. R., Stellar temperatures, 314*, 430.
- DAVIES, A., Continuation of Prof. Arthur Thomson's and Mr. Dudley Buxton's 'Studies of nasal indices in connection with climate' for Africa, 366.
- DAVIES, Dr. H. W., Apparatus for oxygen and CO₂ administration, 371*.
- . . . Hæmophilia, 369.
- DAVIES, W. M., on soil surveys, 409.
- DAVISON, E. H., Cornish pegmatites, 327, 431.
- Variation in composition of Cornish granites . . . , 326, 431.
- DAWE, C. V., A Yorkshire township . . . , 406*.

- DAWKINS, Sir W. BOYD, *on Derbyshire caves*, 301.
 — Place of man in the Tertiary period, 359.
- DAWSON, Dr. E. R., Pancreatic lipase I, 369, 433.
- DAWSON, Prof. H. M., . . . Acid catalysis, 318*, 430.
- DAY, W. R., Forest mycology, 391.
- DEBYE, Prof. P., Polar properties of molecules, 315*.
- DELF, Dr. E. M., *on illumination of plants*, 308.
- Demonstration work on scab of potatoes, by W. A. Millard, 406*.
- Denudation chronology of south-east England, by Dr. S. W. Wooldridge, 323.
- Derbyshire Caves, Report of Committee on*, 301.
- Development of human physiology*, by Dr. C. G. Douglas, 155.
- DICKINSON, R. E., Zones of influence in Leeds, 340.
- Direct and indirect oxydases, by Prof. H. S. Raper, 368, 433.
- Disability in reading, by Miss G. Hume, 372.
- Disease resistance in plants, by F. T. Brooks, 390*, 434.
- Distribution of religious denominations in Wales . . . , by J. E. Daniell, 366, 433.
- DIX, Miss E., and Dr. A. E. TRUEMAN, Marine horizons in coal measures of South Wales and the north of England, 319, 431.
- Dogfish in Faroe-Shetland channel, by C. F. Hickling, 331.
- Dolgarrog dam disaster, Report of committee on, 276.
- DOUGLAS, Dr. C. G., *The development of human physiology*, 155.
- DREVER, Dr. J., Meaning, 373*, 434.
 — *on university course in experimental psychology*, 308.
- DRY, Dr. F. W., Mendelian breeding with Wensleydale sheep, 414, 435.
- DUERDEN, H., Sporangia of Selaginella, 390.
- DUNSHEATH, P., Super tension cables, 351, 432.
- DWERRYHOUSE, Dr. A. R., and A. A. MILLER, Glaciation of Radnorshire . . . , 328.
- Early prehistoric painted pottery of Near and Middle East, by Dr. H. Frankfort, 363, 433.
- Earth's internal heat, . . . Utilising the, by J. L. Hodgson, 350.
- Economic balance between agriculture and forestry, by Dr. J. D. Sutherland, 394, 434.
- Economic situation of agriculture, by A. W. Ashby, 346*.
- EDRIDGE-GREEN, Dr. F. W., Classification of the colour-blind, 374.
 — First recorded cases of colour-blindness, 370, 433.
- Education and industry, Discussion on, 398.
- Education in tropical Africa, Discussion on, 396, 435.
- Effect of certain radiated lipoids . . . , by C. J. Bond, 368, 433.
- Effect of food-supply on multiplication of protozoa, by D. Ward Cutler and L. M. Crump, 335, 431.
- Effect of light on chlorophyll, by Dr. H. Wager, 385*.
- Effect of mental stress on man, by Prof. R. J. S. McDowall, 370.
- Effect of one coloured light on another with reference to theories of colour-vision, by Prof. H. E. Roaf, 370*, 433.
- Efficiency of internal combustion engines, by Prof. W. T. David, 353, 432.
- Electric field on adsorption of ions and neutral molecules . . . , Effect of, by Dr. J. A. V. Butler, 318*.
- Electron impacts, by H. Jones, 314*.
- Embryology of a Mysid crustacean, by Miss S. M. Manton, 332, 432.
- Englishman of the future, The*, by Prof. F. G. Parsons, 138.
- Environment and behaviour, by J. T. Saunders, 330.
- Episodes in the 'Millstone Grit' period, by W. S. Bisat, 319.
- Equations of the gravitational field . . . , by Prof. S. Brodetsky, 315.
- Ethnological survey of Sheffield and surrounding district, by Miss M. McInnes, 367.
- EVERETT, J. H., Technical colleges . . . , 399.
- Evolutionary changes in the superficial sorus, by Prof. F. O. Bower, 384, 434.
- Evolution of vertebrates . . . , by J. Gray, 333.
- EWING, Dr. J., and Miss E. ROUGHTON, Influence of Hydrogen-ion concentration on swelling of plant tissues, 386.
- Experimental control of introspection, by Dr. H. R. de Silva, 379*.
- Experimental removal of Graber's organ in Tabanid fly larvæ, by Prof. A. E. Cameron, 331.
- Extensibility of flax yarns, by J. A. Matthew, 417, 435.
- Factors determining 'natural' rates of mental and physical work, by C. A. Mace, 375.

- Fading of dye-stuffs, by Dr. S. G. Barker, 411, 435.
- FAIRBAIRN, Dr. W. R. D., Religion and fantasy, 379.
- Fallacies and pitfalls of non-statistical economics, by Dr. P. S. Florence, 344, 432.
- FARMER, E., Psychological aspects of accident causation, 373, 434.
- Farming in industrial area of West Riding, by C. G. A. Robertson, 406.
- FAWCETT, Dr. C. B., Position and growth of Leeds, 339.
- FEARNSIDES, Prof. W. G., on critical sections in palæozoic rocks of England and Wales, 275.
- Fechner's Law, by Dr. R. H. Thouless, 374.
- Feeling and psychogalvanic reflex, by R. J. Bartlett, 374, 434.
- Fertility of the sea, by H. W. Hervey, 330.
- Fifteen years in a tropical zoological garden, by H. N. Ridley, 336, 432.
- FISHER, Dr. R. A., Measurements . . . in triplet children . . ., 365, 433.
— on biological measurements, 286.
— on plot technique, 410, 435.
- Fixing of linguistic boundaries by national adoption of Christianity . . ., by Dr. Vaughan Cornish, 338.
- FLEMING, A. P. M., Educational facilities offered by industry, 401.
- FLEURE, Prof. H. S., and Miss R. M. FLEMING, Demonstration of . . . Anthropometric instrument, 361*.
- FLORENCE, Dr. P. S., Fallacies and pitfalls of non-statistical economics, 344, 432.
- FORBES, A. C., Maintenance of permanent soft-wood supplies in north-western Europe, 393.
- FORDHAM, Sir G., Surveys and maps of the Elizabethan period . . ., 341, 432.
- Forest entomology, by Dr. J. W. Munro, 392*.
- Forest mycology, by W. R. Day, 391.
- Forestry and the Empire, by Sir P. Clutterbuck, 393, 434.
- Forestry in relation to climate and erosion, by Dr. T. F. Chipp, 392, 434.
- Forestry in relation to water catchment areas, by Dr. A. W. Borthwick, 393*.
- Forests of Kashmir, by S. K. Mukerji, 395, 434.
- Forests of the Balkan peninsula, by W. B. Turrill, 394, 434.
- Fossil plants of N.E. Greenland, by T. M. Harris, 390*, 434.
- FOSTER, Dr. A. S., Nodal anatomy and morphology of bud-scales in Dicotyledons, 387, 434.
- FRANKFORT, Dr. H., Early prehistoric painted pottery of Near and Middle East, 363, 433.
- FRASER, G. K., Wood derivatives, 391*.
- FRASER, J. A., Value of stoppage analysis with special reference to weaving, 378.
- FREUNDLICH, Prof. H., on structure and formation of colloidal particles, 317.
- FRICTS, Prof. F. E., Genus Sphæroplea, 390, 434.
— . . . *Present-day investigation of Protophyta*, 176.
- GARFITT, G. A., on *Derbyshire caves*, 301.
- GARNETT, Miss A., Capitals of Morocco, 342, 432.
- GARSTANG, Prof. W., Origin of Appendicularians, 331*.
- GARWOOD, Prof. E. J., on *geological photographs*, 259.
- Genus Sphæroplea, by Prof. F. E. Fritsch, 390, 434.
- Geographical range of mollusca . . ., by J. W. Taylor, 336, 432.
- Geographical study of a Yorkshire manor, by H. King, 343*.
- Geography teaching, Report of Committee on*, 299.
- Geological photographs, Report of Committee on*, 259.
- Geological sections in Sladen valley, by R. Barnett, 329.
- Geology of Leeds District, by Prof. A. Gilligan, 318*.
- Geometrical figures from Malekula and Ambrym, by Dr. A. C. Haddon, 364.
- Germination of fungal spores, by Dame H. Gwynne-Vaughan and Mrs. H. S. Williamson, 388, 434.
- GILCHRIST, J., Strength of reinforced concrete beams in shear, 355, 432.
- GILLIGAN, Prof. A., Geology of Leeds District, 318*.
- GINSBERG, Dr. M., on innate differences and social status, 346.
- Glaciation of Radnorshire . . ., by Dr. A. R. Derryhouse and A. A. Miller, 328.
- GRAY, J., Evolution of vertebrates . . ., 333.
- GRAY, Prof. R. WHYTLAW, on structure and formation of colloidal particles, 317.
- Great Barrier Reef, by Rt. Hon. Sir M. Nathan, 339, 432.
- Great Barrier Reef expedition, 1928, by Rt. Hon. Sir M. Nathan and others, 333.
- GREENLY, Dr. E., on *Dolgarrog dam disaster*, 276.

- GRIFFITHS, Dr. E., 'Air conditioning' experiments . . . , 418, 435.
 GROVE, Dr. A. J., Passage of spermatozoa into cocoon in the Brandling worm, 334, 431.
 Growth-promoting substances . . . , by Dr. F. W. Went, 385.
 GULLEBAUD, W. H., Sylvicultural surveys, 392*.
 GWYNNE-VAUGHAN, Dame H., and Mrs. H. S. WILLIAMSON, Germination of fungal spores, 388, 434.

 HADDON, Dr. A. C., Geometrical figures from Malekula and Ambrym, 364.
 HADOW, Sir H., on work of Leeds School of Music and Drama League, 402*.
 Hæmophilia, . . . , by Dr. H. W. Davies, 369.
 HAMILTON, C. J., Theory of co-partnership, 346.
 HARRIS, Miss S., Village Settlements in the Channel Islands, 343, 432.
 HARRIS, T. M., Fossil plants of N.E. Greenland, 390*, 434.
 HARTMANN, Dr. J., Jet wave rectifier, 352*, 432.
 Head-hunting in Assam, . . . , by Dr. J. P. Hutton, 362, 433.
 Heart of the larva of the sea-urchin, by Prof. E. W. MacBride, 332.
 HEDGES, Dr. J. J., Moisture relations of colloidal fibres, 411, 435.
 HEISENBERG, Dr. W., . . . Quantum mechanics, 314*, 430.
 HENDERSON, Sir J. B., *Invention as a link in scientific and economic progress*, 120.
 HENDRICK, Prof. J., on soil surveys, 408.
 HERFORTH, E., Castleford, 340.
 HERVEY, H. W., Fertility of the sea, 330.
 HICKLING, C. F., Dogfish in Faroe-Shetland channel, 331.
 Higher drafts in worsted spinning, by H. Priestman and A. W. Stevenson, 412, 435.
 HILL, G. E., and A. T. WHITAKER, Land utilisation in South Leeds, 340.
 HIRST, H. R., Use of ultra-violet radiation in textile analysis, 412.
 HIRST, Miss M., and Dr. C. G. IMRIE, Some observations on excretion of creatine, 369*, 433.
 HODGSON, J. L., . . . Utilising the earth's internal heat, 350.
 HOLDEN, Dr. H. S., Structure of the endodermis in *Aletris farinosa*, 382, 434.
 Hormones, Discussion on chemistry of, 318*.
 HUDSON, R. G., Mid-Avonian unconformity in the Craven Lowlands, 320*.
 Human skeletons from the north of Scotland . . . , by Prof. T. H. Bryce, 360, 433.
 HUME, Capt. C. W., Slaughtering of animals for food, 405.
 HUME, Miss G., Disability in reading, 372.
 HUMPHREYS, G. N., Ruwenzori, 342.
 HUTTON, Dr. J. P., Head-hunting in Assam, 362, 433.
 HUXLEY, Prof. J. S., *on biological measurements*, 286.
 Hydraulic model illustrating behaviour of the arc, by Prof. W. Cramp, 347, 432.

 Iceland, by J. H. Reynolds, 342*, 432.
Illumination of plants, Report of Committee on, 308.
 Influence of anæsthetics on action of drugs, by Dr. A. D. MacDonald, 369*.
 Influence of forests on rainfall, by C. E. P. Brooks, 392, 434.
 Influence of Hydrogen-ion concentration on swelling of plant tissues, by Dr. J. Ewing and Miss E. Roughton, 386.
 Influence of medium on multiplication of cells growing in vitro, by E. N. Willmer, 369*.
 Influence of ultra-violet light on structure of plants, by Miss M. Martin, 389.
 Influence of ultra-violet radiation on growth of plants, by Miss A. Westbrook, 389, 434.
 INGHAM, A. E., Analytical method in the theory of numbers, 316.
 Inheritance of some colours and patterns in sheep, by J. A. F. Roberts, 413, 435.
 Inheritance on distribution, . . . Influence of, by J. Wedgwood, 345.
 Innate differences and social status, Discussion on, 346.
 Instability of our economic system, by Prof. J. Schumpeter, 344.
 Internal rust spot, by S. Barr, 406*.
 Interpretative map of Dr. Bryn's anthropological observations in mid-Norway, by E. G. Bowen, 366.
 Intracellular structure of wool fibre, by J. B. Speakman, 415, 435.
Invention as a link in scientific and economic progress, by Sir J. B. Henderson, 120.
 Ionization in the lower atmosphere, by Prof. J. J. Nolan, 315*, 430.
 Irish fossil gymnosperms, by Prof. T. Johnson, 384.

 JANSMA, Dr., Land reclamation in Holland . . . , 340.
 JARDINE, W. D. D., Warming, 406*.

- Jet wave rectifier, by Dr. J. Hartmann, 352*, 432.
- JOHNSON, Prof. T., Irish fossil gymnosperms, 384.
- JONES, H., Electron impacts, 314*.
- JONES, Prof. W. Neilson, *on illumination of plants*, 308.
- Junction of 'upper' and 'lower' carboniferous strata, by W. S. Bisat, 319.
- KEITH, Sir A., *Darwin's theory of man's descent as it stands to-day*, 1.
— *on Kent's Cavern*, 303.
- KENNEDY-FRASER, D., Use of elements of school-instruction in psychological investigation, 376.
- Kent's Cavern, Report of Committee on*, 303.
- Kenya Colony . . . , Excavations in, by L. S. B. Leakey and B. H. Newsam, 357.
- KING, A. T., Chemical aspect of wool research, 411, 435.
- KING, H., Geographical study of a Yorkshire manor, 343*.
- King Arthur's cave . . . , by H. Taylor, 362.
- KOLHÖRSTER, Dr. W., . . . , Penetrating rays, 315*, 430.
- LAING, E. V., The living tree, 392.
- LAMB, Commissioner D. C., *Transplantation of boys overseas*, 309.
- Lamprophyres and associated rocks of Mokpalin, Burma, by H. L. Chhibber, 330*.
- LANDER, Dr. C. H., Our available coal supplies and their utilisation, 348*, 432.
- Land reclamation in Holland . . . , by Dr. Jansma, 340.
- Land utilisation in South Leeds, by G. E. Hill and A. T. Whitaker, 340.
- Large low head conduits, by H. Burness, 355*, 432.
- LAURIE, Prof. R. D., Biology in the school curriculum, 335.
- LEAKEY, L. S. B., and B. H. NEWSAM, . . . , Excavations in Kenya Colony, 357.
- Leeds, Position and growth of, by Dr. C. B. Fawcett, 339.
- Leeds School of Music and Drama League, Demonstration, 402*.
- LEWIS, H. P., Zoning of Avonian rocks in south of Isle of Man, 322.
- Living tree, The, by E. V. Laing, 392.
- LLOYD, Dr. L. L., Rancidification and oxidation of olive oil, 418*, 435.
- LOTSY, Dr. J. P., Natural hybrids, 382*, 434.
- LOWERY, H., Musical ability of school-children, 376, 434.
- Low-lift axial flow and centrifugal pumps, by H. R. Lupton and J. H. W. Gill, 353*, 432.
- Lubrication of surfaces under high loads and temperatures, by Dr. T. E. Stanton, 347, 433.
- Luminous discharge in rare gases, by Prof. R. Whiddington, 315*.
- LUPTON, H. R., and J. H. W. GILL, Low-lift axial flow and centrifugal pumps, 353*, 432.
- MCALLISTER, Miss A. H., Speech disabilities, 372.
- MACBRIDE, Prof. E. W., Heart of the larva of the sea-urchin, 332.
- MACDONALD, Dr. A. D., Influence of anaesthetics on action of drugs, 369*.
- MCDOWALL, Prof. R. J. S., Effect of mental stress on man, 370.
- MACE, C. A., Factors determining 'natural' rates of mental and physical work, 375.
- MACGREGOR, Prof. D. H., *Rationalisation of industry*, 98.
- Machine speeds and output, by S. Wyatt, 378*.
- MCINNES, Miss M., Ethnological survey of Sheffield and surrounding district, 367.
- MCINTOSH, A. E. S., Perithecial development in *Nectria mammoidea*, 387.
- MCLEOD, Prof. J. W., Variations in respiratory mechanism amongst bacteria, 368*, 433.
- MCINTOCK, Dr. W. F. P., and J. PHEMISTER, Torsion balance survey over Swinnerton Dyke, 330*.
- MCMILLAN, J. A., Winter feeding of sheep at Garforth, 406, 435.
- MC SWINEY, Prof. B. A., and Dr. BERENBLOOM, Apparatus for regulating pH of solutions for smooth muscle experiments, 371*.
— Observations on the elasticity of arteries, 367.
- MACTAGGART, Miss M. M., . . . Backwardness, 376, 434.
- Maintenance of permanent soft-wood supplies in north-western Europe, by A. C. Forbes, 393.
- MANTON, Miss S. M., Embryology of a Mysid crustacean, 332, 432.
- Marine horizons in coal measures of South Wales and the north of England, by Miss E. Dix and Dr. A. E. Trueman, 319, 431.
- MARQUAND, C. V. B., Arctic Alpine Bryophyte associations in Britain . . . , 390*.

- MARSHALL, Dr. H. Rutgers, Self-consciousness and the self, 377.
- MARTEN, Miss M., Influence of ultra-violet light on structure of plants, 389.
- Mathematical tables, Report of Committee on calculation of*, 220.
- MATHIAS, W. T., Cytology of Callithamnion, 380, 434.
- MATTHEW, J. A., Extensibility of flax yarns, 417, 435.
- MATTHEWS, R. B., Transport on the farm by the aid of electricity, 353, 432.
- Meaning, by Dr. J. Drever, 373*, 434.
- Measurements . . . in triplet children . . ., by Dr. R. A. Fisher, 365, 433.
- Mechanical strength of metal-filament electric lamps, by F. Murgatroyd, 351, 433.
- Mendelian breeding with Wensleydale sheep, by Dr. F. W. Dry, 414, 435.
- Mental unity and mental dissociation*, by Dr. W. Brown, 167.
- Menthones, Menthols and Menthylamines, by Prof. J. Read, 318*, 431.
- MENZIES, Dr. A. C., Regularities in fuse spectra, 314*, 430.
- Metabolic effects of nitrogen, by Dr. W. H. Pearsall, 386*.
- Methods for determining H-ion concentration, by Miss W. J. Wadge, 371*.
- Mid-Avonian unconformity in the Craven lowlands, by R. G. Hudson, 320*.
- MILES, Dr. G. H., Time and motion study as employed by the industrial psychologist, 377.
- Milk production and distribution, Discussion on, 406*.
- MILLARD, W. A., Demonstration work on scab of potatoes, 406*.
- MILLER, S. N., Roman York: the excavations of 1925-26, 356.
- MILLIKAN, Prof. R. A., Relations between Spectra . . ., 314*.
- MILNE, Prof. W. P., and F. P. WHITE, Noether's canonical curves, 314, 430.
- Minor forest products, by W. Dallimore, 391, 434.
- MITCHELL, Dr. T. W., Phenomena of mediumistic trance, 377*, 434.
- Modern Egyptian medicine man, by Miss W. S. Blackman, 362*.
- Moisture relations of colloidal fibres, by Dr. J. J. Hedges, 411, 435.
- Molecular theory of liquid viscosity, by Prof. E. N. da C. Andrade, 315*.
- MONTAG, E., on *Dolgarrog dam disaster*, 276.
- MORISON, C. G. T., *Agriculture and national education*, 202.
- MORISON, Sir T., Educational policy for tropical Africa, 396.
- Morocco, Capitals of, by Miss A. Garnett, 342, 432.
- Movement in Amoeba, by C. F. A. Pantin, 333, 432.
- Mud volcano at Shugo, by Dr. F. Oswald, 330*.
- MUKERJI, S. K., Forests of Kashmir, 395, 434.
- Multiplanar rings . . ., by W. A. Wightman, 318*, 431.
- MUMFORD, Dr. A. A., Body measurements, respiratory tests, and school progress, 361, 433.
- MUNRO, Dr. J. W., Forest entomology, 392*.
- Needs of economic entomology, 337.
- MURGATROYD, F., Mechanical strength of metal-filament electric lamps, 351, 433.
- MURRAY, J. W., New outlooks and tendencies, 398.
- Musical ability of school-children, by H. Lowery, 376, 434.
- MYRES, Prof. J. L., on *Kent's Cavern*, 303.
- NATHAN, Rt. Hon. Sir M., Great Barrier Reef, 339, 432.
- and others, Great Barrier Reef expedition, 1928, 333.
- Natural hybrids, demonstration by Dr. J. P. Lotsy, 382*, 434.
- Nature of action of sunlight on cotton, by Dr. Barr and Miss Hadfield, 417*, 435.
- Nature reserves in Yorkshire*, by T. Sheppard, 425.
- NAYLOR, T. M., Whirling of shafts, 355, 433.
- Needs of economic entomology, by Dr. J. W. Munro, 337.
- New mass spectrograph and the whole number rule, by Dr. F. W. Aston, 315*, 430.
- New Red Sandstone rocks of Arran, by Dr. G. W. Tyrrell and B. H. Barrett, 324, 431.
- NICHOLS, J. E., Coloured fibres in the fleece, 413, 435.
- NICHOLSON, Prof. J. W., on *mathematical tables*, 220.
- Nodal anatomy and morphology of bud-scales in Dicotyledons, by Dr. A. S. Foster, 387, 434.
- Noether's canonical curves, by Prof. W. P. Milne and F. P. White, 314, 430.
- NOLAN, Prof. J. J., Ionization in the lower atmosphere, 315*, 430.
- Non-commutative algebra, by Prof. H. W. Turnbull, 314, 430.
- NUNN, Prof. T. P., on *geography teaching*, 299.

- Observations on *Bifurcaria tuberculata*, by Miss E. M. Rees, 379.
- Observations on elasticity of arteries, by Prof. B. A. McSwiney, 367.
- Occurrence of monascus on desiccated coconut, by J. Stirling, 388, 434.
- OGG, Dr. W. G., Soil profile as basis for intensive soil surveying, 409.
- OGILVIE, Sir F. G., *Address to Conference of Delegates*, 419.
- OLIVER, Dr. T., Predetermination of wool cloth prices, 415, 435.
- Organic growth of the concept . . ., by G. G. Champion, 379*.
- OSWALD, Dr. F., Mud volcano at Shugo, 330*.
- Roman camp of Margidunum . . ., 359.
- Overlap of the bronze and iron ages, by Dr. R. C. C. Clay, 364.
- Overseas life, Report of Committee on educational training for*, 309.
- Oxidation of fatty acids in the body, by Dr. E. J. Wayne, 369, 433.
- Palæozoic Bryophyta . . ., by J. Walton, 385, 434.
- Palæozoic rocks of England and Wales, Report of Committee on critical sections in*, 275.
- Palestine earthquake, 1927, by Dr. B. Willis, 339*.
- Pancreatic lipase I, by Dr. E. R. Dawson, 369, 433.
- Pancreatic lipase II, by Dr. B. S. Platt, 369, 433.
- PANTIN, C. F. A., Movement in *Amœba*, 333, 432.
- Paper pulp from bamboo, by W. Raitt, 395*.
- Parasites of the Phœophyceæ, by Prof. J. Lloyd Williams, 379*.
- PARSONS, Prof. F. G., *The Englishman of the future*, 138.
- Passage of spermatozoa into cocoon in the Brandling worm, by Dr. A. J. Grove, 334, 431.
- PEARSALL, Dr. W. H., Metabolic effects of nitrogen, 386*.
- PEARSON, R. S., Utilisation of soft woods . . ., 391, 434.
- Pectoral fin in mackerel sharks . . ., by Prof. E. E. Prince, 337*.
- PEIRCE, F. T., Problems of textile testing . . ., 417*, 435.
- Penetrating rays, by Dr. W. Kolhörster, 315*, 430.
- PERCIVAL, E., and H. WHITEHEAD, Quantitative examination of fauna of some types of stream bed, 336.
- Perithecial development in *Nectria mammoidea*, by A. E. S. McIntosh, 387.
- Phenomena of mediumistic trance, by Dr. T. W. Mitchell, 377*, 434.
- Phlœem necrosis and starch accumulation in potato leaf-roll, by Dr. T. Whitehead, 388.
- Physical factors on the sandy beach, by J. R. Bruce, 331, 431.
- Physics of psycho-galvanic-reflex phenomenon, by Dr. R. H. Thouless, 370.
- Place of man in the Tertiary period, by Sir W. Boyd Dawkins, 359.
- PLATT, B. S., Pancreatic lipase II, 369, 433.
- Plot technique, Discussion on, 410.
- Polar geography, Some problems of*, by Dr. R. N. Rudmose Brown, 75.
- Polar properties of molecules, by Prof. P. Debye, 315*.
- Post-carboniferous movements in the Northumbrian fault block, by H. C. Versey, 327.
- Potato eel worm, by T. H. Taylor, 406*, 435.
- POULTON, Prof. E. B., *on zoological bibliography and publication*, 284.
- Predetermination of wool cloth prices, by Dr. T. Oliver, 415, 435.
- Prehistoric archæology of the Mendips, by E. K. Tratman, 361.
- Prehistory of Scotland . . ., by Prof. T. H. Bryce, 364, 433.
- Prices and price-control in Great Britain and the United States, by Miss M. Tappan, 345.
- PRIESTMAN, H., and A. W. STEVENSON, Higher drafts in worsted spinning, 412, 435.
- Primitive weaving at Bankfield Museum, by G. R. Carline, 363, 433.
- PRINCE, Prof. E. E., Canadian land-locked salmon, 337*.
- Pectoral fin in mackerel sharks . . ., 337*.
- PRINCE OF WALES, H.R.H. THE, *Message from*, xviii.
- Problems of textile testing . . ., by F. T. Peirce, 417, 435.
- Protophyta . . ., present-day investigations of*, by Prof. F. E. Fritsch, 176.
- Psychological aspects of accident causation, by E. Farmer, 373, 434.
- Psychological effects of flickering light, by Dr. D. N. Buchanan, 374*.
- Psychology of special scholastic disabilities, Discussion on, 372.
- Quantitative determination of physical properties of artificial silk . . ., by A. L. Wykes, 417, 435.

- Quantitative examination of fauna of some types of stream bed, by E. Percival and H. Whitehead, 336.
- Quantum mechanics, by Dr. W. Heisenberg, 314*, 430.
- Race and environment as affecting type of sheep and wool supplies of the world, by Prof. A. F. Barker, 414, 435.
- RAITT, W., Paper pulp from bamboo, 395*.
- Ramanujan's work on congruence properties of the number of partitions of n , by B. M. Wilson, 316, 430.
- Rancidification and oxidation of olive oil, by Dr. L. L. Lloyd, 418*, 435.
- RAPER, Prof. H. S., Direct and indirect oxydases, 368, 433.
- Rapid colorimetric method for measurement of pH, by Miss W. J. Wadge and W. H. Newton, 371, 433.
- Rationalisation of industry*, by Prof. D. H. Macgregor, 98.
- READ, Prof. J., Menthones, Menthols, and Menthylamines, 318*, 431.
- Recent course of prices, by Sir A. Yarrow, 345, 432.
- REES, Miss E. M., Observations on . . . *Bifurcaria tuberculata*, 379.
- Regularities in first spectra, by Dr. A. C. Menzies, 314*, 430.
- Regulation of stomatal behaviour, by Dr. G. W. Scarth, 385.
- Relations between Spectra . . . , by Prof. R. A. Millikan, 314*.
- Relativity, Outstanding problems of*, by Prof. E. T. Whittaker, 16.
- Religion and fantasy, by Dr. W. R. D. Fairbairn, 379.
- Requirements of the population in milk-fat . . . , by Dr. W. Cramer, 369*, 433.
- REYNOLDS, J. H., Iceland, 342*, 432.
- REYNOLDS, Prof. S. H., *on geological photographs*, 259.
- RICHMOND, I. A., Roman camps at Cawthorn, 356.
- RIDLEY, H. N., Fifteen years in a tropical zoological garden, 336, 432.
- ROAF, Prof. H. E., Effect of one coloured light on another with reference to theories of colour-vision, 370*, 433.
- *on colour vision*, 307.
- ROBERTS, J. A. F., Inheritance of some colours and patterns in sheep, 413, 435.
- ROBERTSON, C. G. A., Farming in industrial area of West Riding, 406.
- ROBINSON, Prof. G. W., *on soil surveys*, 408.
- ROBINSON, R. L., British forest policy, 393, 434.
- Roman camp of Margidunum . . . , by Dr. F. Oswald, 359.
- Roman camps at Cawthorn, by I. A. Richmond, 356.
- Roman roads in the valley of the Tiber, by Dr. T. Ashby, 358, 433.
- Roman signal stations on the Yorkshire coast, by R. G. Collingwood, 356.
- Roman York: the excavations of 1925-26, by S. N. Miller, 356.
- Rural settlements in the middle Trent valley, by R. P. Brady, 343.
- RUSSELL, Sir J., *on educational training for overseas life*, 309.
- *on soil surveys*, 407.
- Ruwenzori, by G. N. Humphreys, 342.
- SAUNDERS, Miss E. R., *on the Carpel*, 383.
- SAUNDERS, J. T., Environment and behaviour, 330.
- SCARTH, Dr. G. W., Regulation of stomatal behaviour, 385.
- SCHOFIELD, Dr. H., Engineering training on production, 400, 435.
- School examinations, Discussion on, 402.
- SCHUMPETER, Prof. J., Instability of our economic system, 344.
- SEBELIEN, Prof. J., Study and development of agricultural science in Norway, 404, 435.
- Secondary emission from metallic and metallic oxide targets, by D. Brown and Dr. E. F. Brett, 315*.
- Seismological investigations, Report of Committee on*, 215.
- Self-consciousness and the self, by Dr. H. Rutgers Marshall, 377.
- SETON-KARR, H. W., Traveller's impressions of physical superiority of so-called uncivilised and subject races and its causes, 363.
- SEWARD, Prof. A. C., *on climates of the past*, 386.
- Sex in Cladocera . . . , by A. M. Banta and L. A. Brown, 334.
- SHAW, J. J., *on seismological investigations*, 215.
- SHAW, Sir N., *on upper atmosphere*, 255.
- SHEPPARD, T., *Nature reserves in Yorkshire*, 425.
- SHERRINGTON, Sir C., *on colour vision*, 307.
- SIDGWICK, Dr. N. V., *Co-ordination compounds*, 27.
- SILVA, Dr. H. R. de, Experimental control of introspection, 379*.
- SLATER, Dr. G., Structure of disturbed chalk and diluvium on east coast of Rügen, 320, 431.
- Structure of Mud Buttes and Tit Hills of Alberta, 321, 431.

- Slaughtering of animals for food, by Capt. C. W. Hume, 405.
- SMITH, A. Malins, Algæ of a bog . . ., 380, 434.
- SMITH, RIVERS, Education of the African chief, 396.
- Soil surveys, Discussion on, 407.
- Source of constituents of Lower Greensand and other Aptian sediments, by Prof. P. G. H. Boswell, 323.
- SPEAKMAN, J. B., Intracellular structure of wool fibre, 415, 435.
- Speech disabilities, by Miss A. H. McAllister, 372.
- Sponges and animals, Ancient history of*, by Dr. G. P. Bidder, 58.
- Sporangia of Selaginella, by H. Duerden, 390.
- STANTON, Dr. T. E., Lubrication of surfaces under high loads and temperatures, 347, 433.
- Stellar temperatures, by Dr. C. R. Davidson, 314*.
- Sterility and gigantism in the Lecythidæ, by Prof. J. McLean Thompson, 382, 434.
- STIRLING, J., Occurrence of monascus on desiccated coconut, 388, 434.
- STORY, Prof. F., World's timber supply and consumption, 390.
- STRACHAN, J., Arable dairy farming, 404*.
- Strength of reinforced concrete beams in shear, by J. Gilchrist, 355, 432.
- Structure of disturbed chalk and diluvium on east coast of Rügen, by Dr. G. Slater, 320, 431.
- Structure of endodermis in *Aletris farinosa*, by Dr. H. S. Holden, 382, 434.
- Structure of Mud Buttes and Tit Hills of Alberta, by Dr. G. Slater, 321, 431.
- Studies on the thyroid, by Dr. F. A. E. Crew, 335.
- Study and development of agricultural science in Norway, by Prof. J. Sebelien, 404, 435.
- SUGDEN, Dr. S., on co-ordination compounds, 316.
- Super tension cables, by P. Dunsheath, 351, 432.
- Surveys and maps of the Elizabethan period . . ., by Sir G. Fordham, 341, 432.
- Survival of some ice-age relics in freshwater fauna of Cardiganshire, by Dr. Kathleen E. Carpenter, 336.
- SUTHERLAND, Dr. J. D., Economic balance between agriculture and forestry, 394, 434.
- SVEDELIUS, Prof. N. E., Cytology and development of *Asparagopsis armata*, 380.
- SWIFT, H. W., Transmission of power by belts, 354, 433.
- Switchgear for alternating current, by H. W. Clothier, 351, 432.
- Sylvicultural surveys, by W. H. Guillebaud, 392*.
- TAPPAN, Miss M., Prices and price-control in Great Britain and the United States, 345.
- TAYLOR, H., King Arthur's cave . . ., 362.
- TAYLOR, J. W., Geographical range of mollusca . . ., 336, 432.
- TAYLOR, T. H., Potato eel worm, 406*, 435.
- Teaching and research work on soil chemistry, by Prof. N. M. Comber, 406*.
- Tertiary and Quaternary history of North China, by Prof. G. B. Barbour, 325.
- Tertiary Plutonic centres of Britain*, by Dr. Herbert H. Thomas, 43.
- Theory of co-partnership, by C. J. Hamilton, 346.
- THOMAS, Dr. H. Hamshaw, on the Carpel, 383.
- THOMAS, Dr. Herbert H., Tertiary Plutonic centres of Britain, 43.
- THOMPSON, Prof. J. McLean, Sterility and gigantism in the Lecythidæ, 382, 434.
- THOULESS, Dr. R. H., Fechner's Law, 374.
- Physics of psycho-galvanic-reflex phenomenon, 370.
- Time and motion study as employed by the industrial psychologist, by Dr. G. H. Miles, 377.
- Torsion balance survey over Swinnerton Dyke, by Dr. W. F. P. McLintock and J. Phemister, 330*.
- Transmission of power by belts, by H. W. Swift, 354, 433.
- Transplantation of boys overseas*, by Commissioner D. C. Lamb, 309.
- Transport on the farm by the aid of electricity, by R. B. Matthews, 353, 432.
- TRATMAN, E. K., Prehistoric archæology of the Mendips, 361.
- Traveller's impressions of physical superiority of so-called uncivilised and subject races and its causes, by H. W. Seton-Karr, 363.
- TURNBULL, Prof. H. W., Non-commutative algebra, 314, 430.
- TURNER, F. C., Close voltage rectifier, 352, 433.
- TURNER, Prof. H. H., *on seismological investigations*, 215.

- TURRILL, W. B., Forests of the Balkan peninsula, 394, 434.
- TYRRELL, Dr. G. W., and B. H. BARRETT, New Red Sandstone rocks of Arran, 324, 431.
- University course in experimental psychology, Report of Committee on*, 308.
- Upper atmosphere, Report of Committee on investigation of*, 255.
- Use of elements of school-instruction in psychological investigation, by D. Kennedy-Fraser, 376.
- Use of ultra-violet radiation in textile analysis, by H. R. Hirst, 412, 435.
- USHER, Dr. F. L., on structure and formation of colloidal particles, 317.
- Utilisation of soft woods . . . , by R. S. Pearson, 391, 434.
- VALENTINE, Prof. C. W., Comparative reliability of intuitive judgments of men and women, 379*.
- Value of stoppage analysis with special reference to weaving, by J. A. Fraser, 378.
- Variation in composition of Cornish granites . . . , by E. H. Davison, 326, 431.
- Variations in respiratory mechanism amongst bacteria, by Prof. J. W. McLeod, 368*, 433.
- Vasoligation, etc., Report of Committee on*, 281.
- VERSEY, H. C., Post-carboniferous movements in the Northumbrian fault block, 327.
- Village Settlements in the Channel Islands, by Miss S. Harris, 343, 432.
- Volcanic rocks of Irrawaddy delta, by H. L. Chhibber, 330*.
- WADGE, Miss W. J., Methods for determining H-ion concentration, 371*.
- and W. H. NEWTON, Rapid colorimetric method for measurement of pH, 371, 433.
- WAGER, Dr. H., Effect of light on chlorophyll, 385*.
- White strip on leaf of Crocus, 390*.
- WALLIS, B. C., Position of the school inspector, 403.
- WALLS, E., Educational needs of industry, 399, 435.
- WALTON, J., Palæozoic Bryophyta . . . , 385, 434.
- WARDLAW, Dr. W., Co-ordination compounds of molybdenum, 318*, 431.
- Warping, by W. D. D. Jardine, 406*.
- WATTS, Prof. W. W., *on critical sections in palæozoic rocks of England and Wales*, 275.
- WAYNE, Dr. E. J., Oxidation of fatty acids in the body, 369, 433.
- WEDGWOOD, J., . . . Influence of inheritance on distribution, 345.
- WELLS, G. P., Action of potassium on contractile tissues, 335, 432.
- WENT, Dr. F. W., Growth-promoting substances . . . , 385.
- WESTBROOK, Miss A., Influence of ultra-violet radiation on growth of plants, 389, 434.
- Wheat cultivation in relation to soil types on the Yorkshire Wolds, by Dr. S. E. J. Best, 342.
- WHEELER, Miss E., Backwardness in arithmetic, 372.
- WHEELER, Prof. R. V., Chemistry of coal, 349, 433.
- WHIDDINGTON, Prof. R., Luminous discharge in rare gases, 315*.
- Whirling of shafts, by T. M. Naylor, 355, 433.
- WHITEHEAD, Dr. T., Phloem necrosis and starch accumulation in potato leaf-roll, 388.
- White strip on leaf of Crocus, by Dr. H. Wager, 390*.
- WHITTAKER, Prof. E. T., *Outstanding Problems of Relativity*, 16.
- WIGHTMAN, W. A., Multiplanar rings . . . , 318*, 431.
- WILKINSON, G., Model of Cochlea, 371*.
- WILLIAMS, Prof. J. LLOYD, Parasites of the Phaeophyceæ, 379*.
- WILLIS, Dr. B., Palestine earthquake, 1927, 339*.
- WILLMER, E. N., Influence of medium on multiplication of cells growing in vitro, 369*.
- WILSON, B. M., Ramanujan's work on congruence properties of the number of partitions of n , 316, 430.
- Winter feeding of sheep at Garforth, by J. A. McMillan, 406, 435.
- Wood derivatives, by G. K. Fraser, 391*.
- 'Woodhenge,' by Mrs. M. E. Cunnington, 364, 433.
- WOOLDRIDGE, Dr. S. W., Denudation chronology of south-east England, 323.
- WORDIE, J. M., Colonisation and development in east Greenland, 338.
- World's timber supply and consumption, by Prof. F. Story, 390.
- WORMALL, A., Some properties of complement, 371, 433.
- WRAY, D. A., Carboniferous succession in central Pennine area . . . , 329.

- WYATT, S., Machine speeds and output, 378*.
- WYKES, A. L., Quantitative determination of physical properties of artificial silk . . ., 417, 435.
- WYNN-JONES, Dr. Ll., Appreciation of wit, 373.
- YARROW, Sir A., Recent course of prices, 345, 432.
- Yorkshire township, A, . . ., by C. V. Dawe, 406*.
- YOUNG, N., Problems and personalities at the Accra Teachers' Training College, 397.
- Zones of influence in Leeds, by R. E. Dickinson, 340.
- Zoning of Avonian rocks in south of Isle of Man, by H. P. Lewis, 322.
- Zoological bibliography and publication, Report of Committee on*, 284.



BRITISH ASSOCIATION FOR THE ADVANCEMENT OF SCIENCE

PUBLICATIONS

ON SALE AT THE OFFICE OF THE ASSOCIATION
BURLINGTON HOUSE, PICCADILLY, LONDON, W.1

THE ANNUAL REPORT, containing the Presidential Address and Sectional Addresses, Reports of Research Committees, summary sectional transactions and references to the publication, in the technical press and elsewhere, of individual papers read at the Annual Meeting. 1877 to 1912, 24s. each; from 1921, 25s. each. (The price of any Annual Report from 1831 to 1876 will be quoted on application to the office of the Association. Reports for certain years are out of print).

THE JOURNAL issued at the Annual Meeting, containing short abstracts of many of the papers read, 1s. 6d.

THE ADVANCEMENT OF SCIENCE (published annually since 1920), containing the Presidential Address and Sectional Addresses (thirteen sections). 1922, 1924, 1925, 1926, 1927, 6s. each.

The President's Address and Sectional Addresses, bound together, for 1888, 1889, 1890, 1893, 1895, 1896, 1899, 1900, 1901, 1902, 1909, 1910 (*paper*), each 1s., 1913, 1914, 1915 (*cloth*), 2s.

Addresses by the *Presidents of the Association* are obtainable (*separately*) for several years after 1862, and for all years 1901-1916 (except 1906), each 3d.; for 1919, 6d.; for 1920, 1921, 1922, 1s.; 1923, 1924, 1s. 6d.; 1925 and after, 1s.

Many of the *Sectional Presidents' Addresses* are obtainable separately for years since 1864 down to 1919, each 3d.; for 1919, each 6d.; for 1920 and until further notice, each 1s.

INDEX to the Annual Reports, 1831-60, 12s.; 1861-90, 15s.

THE BRITISH ASSOCIATION: A RETROSPECT, 1831-1921.

By O. J. R. Howarth, Secretary.

Published by the
British Association, Burlington House, London, W.1.

Pp. viii + 318, with 15 plates in half-tone

7s. 6d. (by post, 8s.)

The following LIST OF PUBLICATIONS

refers mainly to those issued since 1900. A new series of "BRITISH ASSOCIATION REPRINTS" was begun in 1922, in standard paper covers; these are indicated by heavy type. Enquiries for earlier Reports, etc., and for shorter papers for recent years not included in the following list, should be addressed to the office.

Lalande's Catalogue of Stars, £1 1s.

Stellar Distribution and Movements, by A. S. Eddington, M.Sc., 1911, 3d.

Seismology, 1900, 1s.; 1904, 1s.; 1905, 1s.; 1907, 6d.; 1908, 1s.; 1910, 1s.; 1912, 1s.; 1913, 1s.; 1914, 1s.; 1915, 1s.; 1918, 6d.; 1922, 1s.; 1923, 6d.; 1924, 6d.; 1925, 6d.; 1926, 6d.; 1927, 6d.

Catalogue of Destructive Earthquakes, A.D. 7 to A.D. 1899, by Dr. J. Milne, F.R.S., 1912, 5s.

Investigation of the Upper Atmosphere, 1927, 6d.

Bibliography of Spectroscopy, in continuation of 1894 Report, 1898, 1s. 6d.; 1901, 1s. 6d.

Note sur l'Unité de Pression, par le Dr. C. E. Guillaume, 1901, 3d.

Note on the Variation of the Specific Heat of Water, by Prof. H. L. Callendar, 1901, 4d.

On Threefold Emission Spectra of Solid Aromatic Compounds, by Prof. E. Goldstein, 1909, 3d.

Anode Rays and their Spectra, by Dr. Otto Reichenheim, 1909, 3d.

Report on the Determination of Gravity at Sea, 1916, 1s. 6d.; 1919, 1s. 6d.

Report on Tides, 1921, 1s.; 1923, 1s.

The History and Present State of the Theory of Integral Equations, by H. Bateman, 1910, 1s. 6d.

Calculation of Mathematical Tables, 1922, 1923, 1924, 1925, 1926, 1927, 1s. each.

Wave-lengths, 1899, 1s.; 1900, with Index to Tables from 1884 to 1900, 1s.; 1901, 1s.

Chemical Compounds contained in Alloys, by F. H. Neville, F.R.S., 1900, 6d.

The Constitution of Camphor, by A. Lapworth, D.Sc., 1900, 1s.

Absorption Spectra and Chemical Constitution of Organic Compounds, 1922 (B.A. Reprints, n.s., No. 12), 1s. 6d.

The Methods for the Determination of Hydrolytic Dissociation of Salt Solutions, by R. C. Farmer, 1901, 6d.

The Application of the Equilibrium Law to the Separation of Crystals from Complex Solutions and to the Formation of Oceanic Salt Deposits, by Dr. E. Frankland Armstrong, 1901, 1s.

Our Present Knowledge of Aromatic Diazo-compounds, by Dr. Gilbert Thomas Morgan, 1902, 6d.

The Present Position of the Chemistry of Rubber, by S. S. Pickles, 1906, 6d.

The Present Position of the Chemistry of Gums, by H. Robinson, 1906, 3d.

Diffusion in Solids, by Dr. C. H. Desch, 1912, 3d.

Solubility, by J. Vargas Eyre, Ph.D. Part I., 1910, 1s.; Part II., 1913, 1s.

Fuel Economy, 1916, 6d.; 1919, 6d.; 1922, 1s.

The Structure of Molecules (Discussion), (B.A. Reprints, n.s., No. 2), 1921, 9d.

The Nitrogen Industry (Discussion), (B.A. Reprints, n.s., No. 14), 1922, 9d.

The Botanical and Chemical Characters of the Eucalypts and their Correlation, 1915, 1s.

Non-aromatic Diazonium Salts, 1921, 6d.

Changes in the Sea Coast, 1903, 1s.

Life-zones in the British Carboniferous Rocks, 1901, 6d. ; 1902, 6d. ; 1904, 6d.

The Formation of "Rostro-Carinate" Flints, by Professor W. J. Sollas, F.R.S., 1913, 3d.

Lower Carboniferous Zonal Nomenclature, 1925, 1s.

A List of Characteristic Fossils (B.A. Reprints, n.s., No. 18), 1924, 1s.

Rules of Zoological Nomenclature, 1s.

Digest of Observations on the Migration of Birds, made at Lighthouses, by W. Eagle Clarke, 1896, 6d.

Migratory Habits of the Song-thrush and the White Wagtail, by W. Eagle Clarke, 1900, 6d.

Migratory Habits of the Skylark and the Swallow, by W. Eagle Clarke, 1901, 6d.

Migratory Habits of the Fieldfare and the Lapwing, by W. Eagle Clarke, 1902, 6d. ; 1903, 6d.

Melanism in Yorkshire Lepidoptera, by G. T. Porritt, 1906, 6d.

Biological Problems incidental to the Belmullet Whaling Station, 1912, 3d. ; 1914, 1s.

On the Phylogeny of the Carapace, and on the Affinities of the Leathery Turtle, *Dermochelys coriacea*, by Dr. J. Versluys, 1913, 6d.

Zoology Organization, 1921, 3d.

Biological Measurements, 1927, 6d.

Amount and Distribution of Income (other than Wages) below the Income-tax Exemption Limit in the United Kingdom, 1910, 6d.

Effects of the War on Credit, Currency, and Finance, 1915, 6d. ; 1921 (B.A. Reprints, n.s., No. 3), 1s. 6d. ; 1922 (B.A. Reprints, n.s., No. 15), 6d.

The Question of Fatigue from the Economic Standpoint, 1915, 6d. ; 1916, 6d.

Second Report on a Gauge for Small Screws, 1884, reprinted 1895, 6d.

Report on giving practical effect to the Introduction of the British Association Screw Gauge, 1896, 6d. ; 1901, 6d. ; 1903, 6d.

Report on Proposed Modification of the Thread of the B.A. Screw, 1900, 6d.

Resistance of Road Vehicles to Traction, 1901, 3d.

The Road Problem, by Sir J. H. A. Macdonald, 1912, 3d.

Standardisation in British Engineering Practice, by Sir John Wolfe-Barry, K.C.B., 1906, 3d.

The Proper Utilisation of Coal, and Fuels derived therefrom (Discussion), 1913, 6d.

Liquid, Solid, and Gaseous Fuels for Power Production, by Professor F. W. Burstall, 1913, 3d.

The Standardisation of Impact Tests, 1918, 9d.

Stress Distributions in Engineering Materials, 1914, 1s. ; 1921 (B.A. Reprints, n.s., No. 4), 3s. 6d. ; 1923 (B.A. Reprints, n.s., No. 17), 3s.

Aeronautical Problems of the Past and of the Future, by R. V. Southwell, F.R.S. (B.A. Reprints, n.s., No. 19), 1925, 1s. 6d.

Progress of Anthropological Teaching, 1923, 6*d.*
Ethnological Survey of Canada, 1899, 1*s.* 6*d.* ; 1900, 1*s.* 6*d.* ; 1902, 1*s.*
Artificial Islands in the Lochs of the Highlands of Scotland, 1912, 3*d.*
Physical Characters of the Ancient Egyptians, 1914, 6*d.*
The Age of Stone Circles, 1922, 1*s.*

The Claim of Sir Charles Bell to the Discovery of Motor and Sensory Nerve Channels (an Examination of the Original Documents of 1811-1830), by Dr. A. D. Waller, F.R.S., 1911, 6*d.*
Heat Coagulation of Proteins, by Dr. Chick and Dr. Martin, 1911, 3*d.*

Curricula of Secondary Schools, 1907, 3*d.*
Mental and Physical Factors involved in Education, 1910, 3*d.*
The Influence of School Books upon Eyesight, 1913 (Second Edition, revised), 4*d.*
The Teaching of Botany in Schools, 1903, 3*d.*
Report on Atlas, Textual, and Wall Maps for School and University use, 1915, 6*d.*
Report on Popular Science Lectures, 1916, 6*d.*
Science Teaching in Secondary Schools, 1917, 2*s.* 6*d.*
The "Free Place" System in Secondary Education, 1918, 6*d.*
Museums in relation to Education, 1920, each 6*d.*, or for 6 or more copies, 2*d.*
Training in Citizenship, 1920, 1*s.* (9*s.* per doz.); 1921, 6*d.* (5*s.* per doz.); 1922, 6*d.* (4*s.* per doz.). (B.A. Reprints, n.s., Nos. 8, 9, 11.)
Imperial Citizenship, by the Rt. Hon. Lord Meston, 1922 (B.A. Reprints, n.s., No. 13), 9*d.* (6*s.* per doz.).
Science and Ethics, by Dr. E. H. Griffiths, F.R.S. (B.A. Reprints, n.s., No. 1), 1921, 9*d.*
Charts and Pictures for use in Schools (B.A. Reprints, n.s., No. 5), 1921, 1*s.*
An International Auxiliary Language (B.A. Reprints, n.s., No. 6), 1921, 1*s.*
Geography Teaching (B.A. Reprints, n.s., No. 16), 1*s.* (10*s.* per doz., £4 per 100).
Educational Training for Overseas Life, 1924, 1925, 1927, 6*d.* each.

The Development of Wheat Culture in North America, by Professor A. P. Brigham, 1909, 3*d.*

BRITISH ASSOCIATION REPORTS

PUBLISHED ELSEWHERE. (*Not obtainable from the Association Office.*)

BRITISH ASSOCIATION REPORTS ON ELECTRICAL STANDARDS, Cambridge University Press, 1913, 12*s.* 6*d.*

BRITISH FINANCE, 1914-21, edited by Professor A. W. Kirkaldy, Pitman & Sons, 1921, 10*s.* 6*d.*

BRITISH LABOUR, 1914-21, edited by Professor A. W. Kirkaldy, Pitman & Sons, 1921, 10*s.* 6*d.*

First Second, Fourth and Fifth REPORTS ON COLLOID CHEMISTRY, published by H.M. Stationery Office (prices on application thereto).

Printed by
SPOTTISWOODE, BALLANTYNE & Co. LTD.
London, Colchester & Fton

