



This is a digital copy of a book that was preserved for generations on library shelves before it was carefully scanned by Google as part of a project to make the world's books discoverable online.

It has survived long enough for the copyright to expire and the book to enter the public domain. A public domain book is one that was never subject to copyright or whose legal copyright term has expired. Whether a book is in the public domain may vary country to country. Public domain books are our gateways to the past, representing a wealth of history, culture and knowledge that's often difficult to discover.

Marks, notations and other marginalia present in the original volume will appear in this file - a reminder of this book's long journey from the publisher to a library and finally to you.

Usage guidelines

Google is proud to partner with libraries to digitize public domain materials and make them widely accessible. Public domain books belong to the public and we are merely their custodians. Nevertheless, this work is expensive, so in order to keep providing this resource, we have taken steps to prevent abuse by commercial parties, including placing technical restrictions on automated querying.

We also ask that you:

- + *Make non-commercial use of the files* We designed Google Book Search for use by individuals, and we request that you use these files for personal, non-commercial purposes.
- + *Refrain from automated querying* Do not send automated queries of any sort to Google's system: If you are conducting research on machine translation, optical character recognition or other areas where access to a large amount of text is helpful, please contact us. We encourage the use of public domain materials for these purposes and may be able to help.
- + *Maintain attribution* The Google "watermark" you see on each file is essential for informing people about this project and helping them find additional materials through Google Book Search. Please do not remove it.
- + *Keep it legal* Whatever your use, remember that you are responsible for ensuring that what you are doing is legal. Do not assume that just because we believe a book is in the public domain for users in the United States, that the work is also in the public domain for users in other countries. Whether a book is still in copyright varies from country to country, and we can't offer guidance on whether any specific use of any specific book is allowed. Please do not assume that a book's appearance in Google Book Search means it can be used in any manner anywhere in the world. Copyright infringement liability can be quite severe.

About Google Book Search

Google's mission is to organize the world's information and to make it universally accessible and useful. Google Book Search helps readers discover the world's books while helping authors and publishers reach new audiences. You can search through the full text of this book on the web at <http://books.google.com/>

34.62.110

War 4398.56

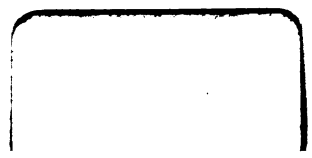









REPORTS OF EXPERIMENTS

WITH

SMALL ARMS

FOR

THE MILITARY SERVICE,

BY

OFFICERS OF THE ORDNANCE DEPARTMENT,

U. S. ARMY.

United States - Bureau of Ordnance.

PUBLISHED BY AUTHORITY OF THE SECRETARY OF WAR.

WASHINGTON:
A. O. P. NICHOLSON, PUBLIC PRINTER.
1856.

War 4398.56

1863. May 2.

Copy of
the Ordnance Dept.
through

Gen. James W. Ripley
Chief of Ordnance.

ORDNANCE OFFICE,
Washington, May 27, 1856.

SIR: In previous reports I have mentioned, that the superiority in range and accuracy of fire of elongated balls, fired from grooved barrels, had induced investigations in relation both to the most advantageous shape of the ball, and the best mode of grooving the arm; that some experiments in regard to both these points had then been made, which it was intended to prosecute further; that they were believed to be of sufficient value and interest to warrant their publication for general distribution; and that they would be prepared and presented with that view. These experiments, including many interesting points in relation to small arms of different kinds, have been completed, and reports of the same prepared, the character of which is indicated by the enclosed table of contents.

* * * * *

I recommend that the work be printed for the use of the army, and for distribution to the militia, not doubting that it will afford information useful and interesting to both.

Respectfully, your obedient servant,

H. K. CRAIG,
Colonel of Ordnance.

Hon. JEFFERSON DAVIS,
Secretary of War.

Approved.—May 31, 1856.

JEFFERSON DAVIS,
Secretary of War.

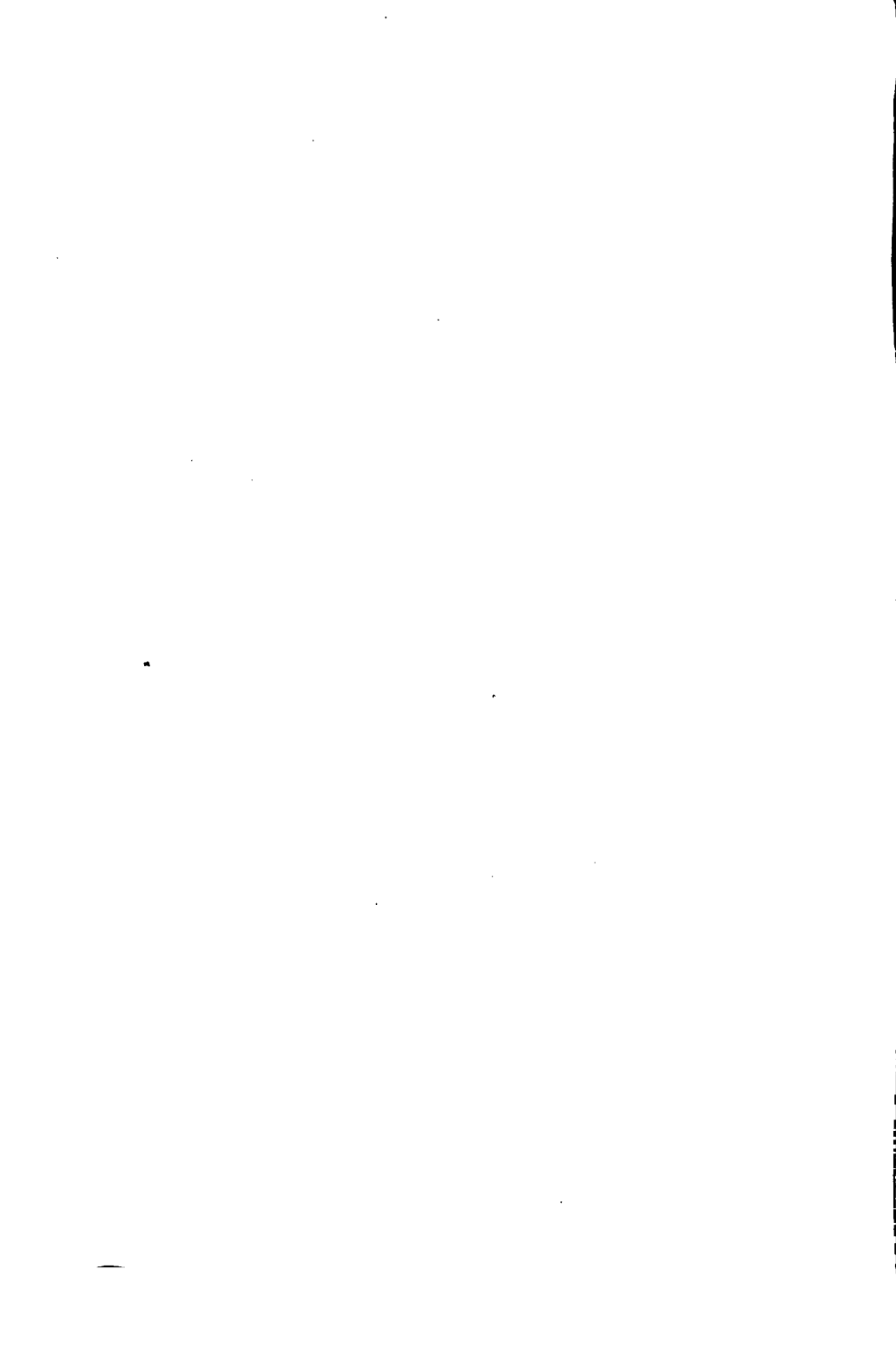

CONTENTS.

PART I.

Col. Huger's report of experiments made at Harper's Ferry Armory, 1853-'54.

Rifles à tige, }
Regulation rifles, }
Regulation musket. }
Grooves of increasing depth.
Grooves of increasing twist.
Ball à tige.
Minié ball.
Expanding balls, compound.
Expanding balls, simple.
Service balls, round.
Tables of firing with the above.
Tables of firing with Sharp's carbine.
Drawings of balls.

PART II.

Extract from Lieut. Benton's report of experiments made at Harper's Ferry Armory in the fall of 1854, with various kinds of grooves for the regulation rifle.

Harper's Ferry ball.
Pritchett ball,
Round ball.
Tables of firings.
Drawings of balls and grooves.

PART III.

Report of Lieut. Benton's experiments made at Springfield Amory in 1855, for the purpose of revising and improving the entire system of small arms.

Description of experimental arms, with drawings of grooves.

Description of experimental projectiles, with plate.

Description of firing machine, with plate.

Mode of conducting experiments

Tables showing positions of centres of impact.

Table of mean drift.

Tables of mean deviations for experimental arms.

Tables of comparative mean deviations for various arms.

Conclusions as regards—

Calibre,

Length of barrel,

Grooves,

Projectiles, &c.

PART IV.

Nomenclature and list of arms established.

Table of principal dimensions, weights, &c.

Tables of mean deviations.

New rifle-musket. (Fired from fixed rest.)

Altered rifle. (Fired from fixed rest.)

Altered musket. (Fired from fixed rest.)

Pistol-carbine. (Fired from shoulder and rest.)

Table of elevations.

Heights of rear sights.

Table of penetrations.

Points of trajectories.

Firing rifled barrels with increased charges.

Mean deviations. New rifled-musket, when fired from a shoulder and rest.

Drawings of balls adapted for new arms.

APPENDIX.

PART I.

Extracts from a work on rifles, by L. Panôt, instructor at Vincennes, France.

Rotary motion of ball.

Grooves.

Form of elongated ball.

Gaining twist.

Variations in depth of grooves.

Carabine à tige.

Comparative penetrations of wall piece and carabine à tige.

Theory of flight of cylindro-conical ball.

Theory of "dérivation," or drift.

Times of flight.

Tables of mean deviations.

Comparison of infantry musket and musket altered à tige.

Penetration " " " "

Mean deviations " " " "

Minié ball.

Self-expanding ball of Captain Fauconpret.

Rear sight.

Mode of determining graduations.

Mode of determining trajectories.

Causes of deviations in firing.

PART II.

Extract from a report of experiments with small arms, made at Enfield, England, by Colonel Gordon, 1853.

Mr. Purdy's musket and projectile.

Mr. Lovell's " "

Mr. Greener's " "

Mr. Richards's " "

Mr. Lancaster's " "

Mr. Wilkinson's " "

Mr. Pritchett's projectile.

New Enfield musket.

Practice at Hythe.

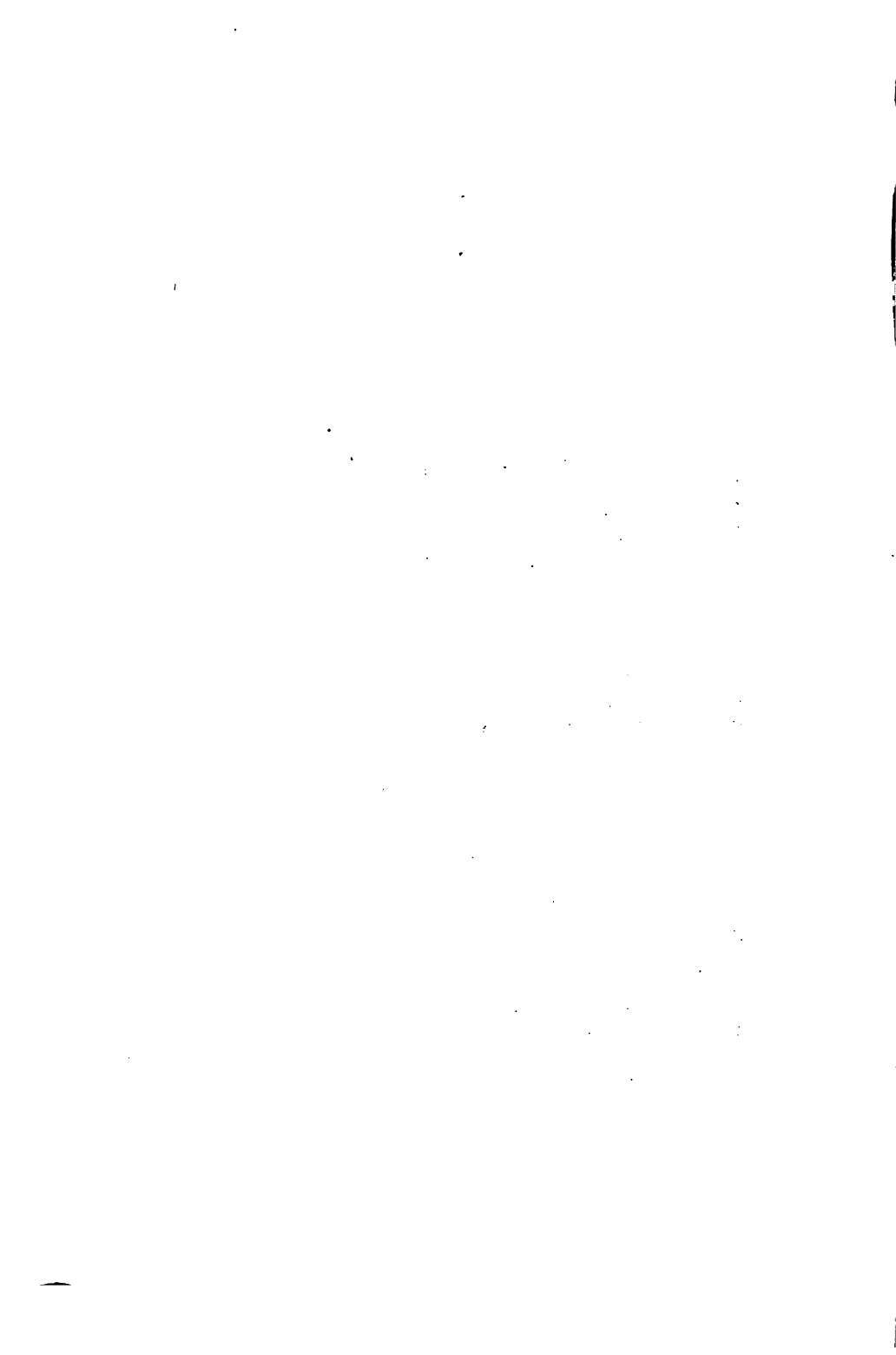

PART I.

REPORT
OF
EXPERIMENTS WITH THE RIFLE À TIGE;
ALSO, WITH
THE MINIE BULLETS, AND A NEW EXPANDING BULLET,
ADAPTED TO THE REGULATION RIFLE,
MADE AT THE
U. S. ARMORY, HARPER'S FERRY.
1853-'4.

NOTE.

For information concerning terms used, and the principles connected with the flight of elongated projectiles, see extracts from the work of M. Panôt, appended hereto.

REPORT.

The Colonel of Ordnance having authorized experiments to be made at the Armory with rifles, firing elongated bullets, on the “*tige*” and Minié principles, seven rifles of musket calibre were made. The length of barrel for all was 33 inches. The annexed table, No. 1, gives a description of these guns.

Nos. 1, 2, 3, and 4, were musket barrels cut to this length; *two*, Nos. 8 and 9, were special barrels, a little heavier, each weighing nearly one pound more than the others; and *one*, No. 5, was a cast steel rifle barrel, reamed up to the musket calibre, and weighed $4\frac{1}{2}$ ounces more than the first mentioned. *Two*, Nos. 6 and 7, were rifle barrels, also prepared for experiment.

Gun No. 10, of the table, is a *regulation rifle* barrel, without any alteration in its construction. Guns 6 and 7, rifle calibre, were very little used. They were not tried with the “*tige*” (stem;) and the original Minié bullet, and the first modification made of it, (see figure 7,) did not answer with this calibre; they, therefore, do not appear in the table of experiments.

It will be seen that *five* grooves has been adopted as a suitable number.

With expanding bullets, there should be an odd number of grooves in the bore of the barrel, in which case, a *groove* will be opposite a *land*; for when the ball is forced, each land tends to push the opposite part of the ball into a groove, consequently the ball is less deformed than where

the number of grooves is even, when a *land* would be opposite a *land*, and a *groove* opposite a *groove*.

The results of the experiments are very similar, and compare favorably with those recorded as the mean of many trials in M. Panôt's work. (See Appendix.)

The conclusion arrived at from observing the effects of the different degrees of *twist* to the grooves, as described in table No. 1, is, that a greater twist than one turn in *six* feet, increased the "*dérivation*"—a term applied by the French writers to a lateral deviation of the ball, which occurs in the direction of the grooves of the rifle. If the grooves cause the ball to rotate from *left* to *right*, the ball will go to the right of the point aimed at; whereas, if it revolves from *right* to *left*, it will go to the left. (See Appendix.) This deviation is variable, increasing in a greater ratio than the distance fired, and it is greater as the rotary motion of the ball is more rapid; in the guns giving a twist of *one* turn in *four* and *five* feet, it was found necessary to re-adjust the sights for long distances.

Therefore, a greater twist than one turn in *six* feet is not necessary nor advantageous.

In the experiments with the regulation rifle (twist of grooves, one turn in six feet,) with the expanding balls, the "*dérivation*" was not appreciable at 500 yards range.

The "*gaining twist*" did not show any advantages in these experiments.

The grooves are more difficult to cut, and for elongated balls are not applicable, for, the portion of the cylindrical part which fills the grooves is constantly changing its shape, in its course through the grooves.

The "*tige*," or stem of steel, although answering well for the purpose of expanding the ball, is inconvenient in cleaning the arm, and requires a nicety in loading, which

is difficult for the soldier to attain, viz: the ball must not be rammed too much nor too little.

In the French rifle, it projects into the barrel 1.49 inch ; is screwed into the breech pin for 0.4 inch ; and its diameter is 0.35 inch.

The plan proposed by Captain Minié, of loading with a ball which goes in free, and is forced into the grooves at the instant of discharge by the action of the gas upon it, has been preferred, as being more simple.

The balls of this kind, made according to the description of those used in France, did not succeed in our experiments. (See figure 2.) The cup was often driven so forcibly into the ball as to cause the ball to break. Mr. Burton, the acting master armorer, who conducted the experiments, contrived a different method of expanding the ball by a plug of hard metal. (See figure 3.) This plug answered the purpose, and the firing at 200 yards was very good. (See table 3.) The plug was *cast* of a mixture of lead and tin, and was easily made. The objections to it were, that this piece fell out after a short flight, and might do injury in firing *over* our own men ; it required a little greater elevation than with the "tige" at the same distances ; and the paper of the cartridge around the bottom, forming the patch to the ball, was nipped by the plug being driven up suddenly. Efforts were made to find a better form of plug, and this bullet was not tried at ranges exceeding 200 yards.

The compound bullet, shown by figure 5, was then contrived. This was made up in the cartridge like the others, and when the ball was down upon the powder, one blow with the rod caused the projecting point to settle down upon the shoulder on the upper part of the ball, and the lower part was expanded into the grooves. The practice with this bullet at 200 yards shows that it answers the purpose—the

firing being as good as with the same gun, and the tige. (See Table 4.) The objections to this ball are, its being in two parts; and the ramming, which will cause the powder to cake. Although this made no difference in the experiments where the gun was fired at once, it might be objectionable in service where the arm is liable to remain loaded for a long time.

All these experiments were made with cartridges, as in service, and the guns were all fired from the shoulder and a rest.

There are objections to using the elongated bullet in any form with the musket calibre—0.69 inch, viz:

1st. The great weight of the ball, which, for the "tige," weighs $1\frac{3}{4}$ oz. This makes the weight of the ammunition to be carried by the soldier quite burdensome, and the transportation of sufficient supplies over our extended frontiers would be very expensive.

2d. With this weight of ball, the charge of powder must be limited by the recoil the men can bear. With the French rifle it is about one-eleventh the weight of the ball, and with our rifles of musket calibre we could not exceed this amount.

Some of the modified Minié bullets could be fired with a charge of powder equal to one-tenth the weight of the ball. In our experiments with the rifle calibre, one-eighth the weight of the ball was found the most efficient charge.

Considering that it would be very advantageous to use our present regulation rifle (diameter of bore 0.54 inch) with the elongated bullet, and trials with the first balls proposed, (the original Minié, and the hard metal plug having failed,) efforts were made to contrive a modified Minié bullet that would answer for this smaller calibre. After several trials to contrive a *plug* that would act with certainty, Mr. Burton

hit upon the expedient of hollowing out the bottom of the bullet, and making the edges thin enough to be forced outwards by the action of the gas at the instant of the explosion of the charge, thus causing it to fill the grooves and receive its rotary motion.

The bullet was used *naked*, without paper, or patch of any kind. (See fig. 4.) It was found by experiment that this bullet, which weighed 310 grains, would not bear a charge of more than 38 grains, and, although the practice at 200 yards was very good, (see table No. 5,) it was found not to hold up well at longer ranges. In these trials it was found that musket powder answered better with this ball than *rifle* powder; and the gun did not foul near so rapidly. The bullet fits the bore very snugly, and the cylindrical part, and the grooves being dipped in melted grease, it lubricates the bore and keeps it clean. Fifty rounds have been fired without wiping out; and twenty-five rounds were always fired without any cleaning whatever.

At this stage of the trials "the report of experiments made in England in 1852" was first seen; extracts from which are appended hereto, (See Appendix.)

It will be seen that these experiments are very similar to ours, and the conclusion arrived at, on important points, are the same, viz:

1. The reduced diameter of the bore. The proposed English rifle is 0.577 in diameter bore; our rifle is 0.540 inch.

2. To make the ball fit the bore snugly without patch of any kind, and to hollow its base out in such a manner that it shall be expanded into the grooves by the action of the charge.

3. That the coarse grained powder (musket) is most advantageous; it acts more regularly on the ball, and fouls less in the gun.

To render this bullet with the cavity more efficient at long ranges, its weight was increased by making it longer. (See figure 6.) It weighs 400 grains and the charge of powder is 50 grains, making the proportion one-eighth. Trials at different distances, up to 450 yards, are given in table No. 6. It will be seen that the practice was closer up to this distance with this ball than with any of the preceding; and it would no doubt be equal to the "tige" at longer distances.

This result appears very favorable; and two rifles, arranged for using this new bullet, with a supply of ammunition, were ordered to be sent to the Washington Arsenal for further experiments. If, on more extended trials, they are found to answer, the range and efficiency of our rifle can be more than doubled at once, and at a trifling expense. It will only be necessary to make new ramrods and breech-sights, (guides,) which can be made at the armory, and sent and applied to the arms whenever they may be wanted. The old rods can be returned and altered. These two items, and a supply of ammunition, are all that is required.

To give the spherical ball, heretofore used, a fair trial on equal terms, as Sir Charles Napier recommended, a new musket of the exact calibre was fitted with the same breech-sight or guide used on the rifles "á tige," and fired from the same rest, and with every precaution necessary to insure accuracy.

The annexed table of the firing, (see table No. 7,) shows that, at 300 yards, the musket is not as accurate as the new rifle bullet at double the distance; and at 400 yards, the fire of the musket is so uncertain as to be useless.

To compare the spherical ball with the new elongated ball in the rifle, a supply of rifle cartridges was procured from the Washington Arsenal, and fired from the same rifle used in the trials with the elongated ball. The annexed

table, No. 8, gives the results of these trials, which show that the limit of accuracy with the spherical ball is between 200 and 300 yards ; over this latter distance it fails entirely.

* * * * *

With the rifle ammunition proposed, when the ball is to be used without a patch, the pinched end of the cartridge is bitten off and the powder poured in, in the usual manner, the cylinder is broken off and the wrapper torn from the ball, which is inserted in the bore and pushed home with the ramrod ; a single light blow of the rod causes it to expand sufficiently against the sides of the bore to prevent its falling out, if the muzzle is held downwards and jarred.

Rifles with new ramrods and breech-sights arranged for 150, 300, and 450 yards range, with a supply of cartridges and extra bullets, are submitted for examination and further trials. By direction of the Colonel of Ordnance, a rifle is also submitted with a sword bayonet attached ; the sword to be worn habitually as a side arm, and in case of need it can be promptly and firmly attached by a very simple lock to the muzzle of the rifle, and used as a bayonet.

BENJ. HUGER,
Bvt. Col. U. S. A.

PIKESVILLE ARSENAL,
March 18, 1854.

TABLE No 1.—NUMBER AND DESCRIPTION OF ARMS MADE.

Nos. on guns.	Diameter of bore.		Diameter of barrel.		Length of barrel.	Total length of arm.	Weight of barrel.	Weight of arm complete.	No. of grooves in barrel.	Width of grooves.	Depth of grooves.		REMARKS.
	Inch.		Inch.	At muzzle.							Inch.	At breech.	
1	.69		1.25	.87	33.	48.8	3.13	8.11½	5	.22	.02	.0125	Twist of grooves.—Gaining twist, ending at muzzle, with one turn in four feet.
2	.69		1.25	.87	33.	48.8	3.13	8.11½	5	.22	.02	.0125	Twist of grooves.—Gaining twist, half the length of the barrel from breech regular six-foot twist, ending with one turn in four feet.
3	.69		1.25	.87	33.	48.8	3.13	8.11½	5	.22	.02	.0125	Twist of grooves.—Regular twist, one one turn in four feet.
4	.69		1.25	.87	33.	48.8	3.13	8.11½	5	.22	.02	.0125	Twist of grooves.—Regular twist, one turn in six feet.
5	.69		1.15	.90	33.	48.8	4.1½	8.10½	5	.22	.02	.0125	Twist of grooves.—Regular twist, one turn in five feet.
6	.54		1.15	.90	33.	48.8	5.5	9.15½	5	.12	.02	.0125	Twist of grooves.—Regular twist, one turn in four feet.
7	.54		1.15	.90	33.	48.8	5.5	9.15½	5	.12	.02	.0125	Twist of grooves.—Gaining twist, half the length of the barrel from the breech regular six-foot twist, ending with one turn in four feet.
8	.69		1.25	.94	33.	48.8	4.11½	9.6½	5	.22	.02	.0125	Twist of grooves.—Gaining twist, half the length of the barrel from the breech regular six-foot twist, ending with one turn in four feet.
9	.60		1.25	.94	33.	48.8	4.11½	9.6½	5	.22	.02	.0125	Twist of grooves.—Regular twist, one turn in four feet.
10	.54		1.15	.90	33.	48.8	5.5	9.10½	7	.11	.02	.02	Twist of grooves.—Regular twist, one turn in six feet; regulation rifle.

TABLE No. 2.—*Target practice at 200 yards.—Rifle “à tige.”*

(For bullet, see Plate, fig. 1.)

Number of gun fired.	Size of target.	No. shots fired.	Mean perpendicular deviation.	Mean horizontal deviation.	Mean absolute deviation.
	Feet.		Inches.	Inches.	Inches.
Gun No. 1 - - - - -	5 by 10	25	8.83	4.97	11.57
Gun No. 2 - - - - -	“	“	7.02	6.93	10.96
Gun No. 3 - - - - -	“	“	6.28	6.76	10.38
Gun No. 4 - - - - -	“	“	8.13	7.77	12.90
Gun No. 5 - - - - -	“	“	13.23	9.27	17.48
Gun No. 8 - - - - -	“	“	16.50	10.68	20.86
Gun No. 9 - - - - -	“	“	8.33	5.29	10.70

Weight of bullet used in this practice 796 grains.

Charge of powder 68 grains.

NOTE.—The deviations are referred to the centre of the target—the centre of impact being made to coincide as nearly as possible with this point.

Target practice at 300 yards.—Rifle “à tige.”

Number of gun fired.	Size of target.	No. shots fired.	Mean perpendicular deviation.	Mean horizontal deviation.	Mean absolute deviation.
	Feet.		Inches.	Inches.	Inches.
Gun No. 1 - - - - -	10 by 10	25	21.48	8.25	24.24
Gun No. 2 - - - - -	“	“	23.54	14.67	29.72
Gun No. 3 - - - - -	“	“	14.39	10.17	18.74
Gun No. 4 - - - - -	“	“	14.71	14.44	23.88
Gun No. 5 - - - - -	“	“	9.37	13.57	18.50
Gun No. 8 - - - - -	“	“	25.79	14.13	31.70
Gun No. 9 - - - - -	“	“	15.40	9.82	19.73

TABLE No. 2.—Target practice at 400 yards.—Rifle "à tige."

No. of gun fired.	Size of target.	No. of shots fired.	Mean perpendicular deviation.	Mean horizontal deviation.	Mean absolute deviation.	Remarks.
	Feet.		Inches.	Inches.	Inches.	
Gun No. 1	8 by 16	25	19.01	10.36	25.04	12 per cent. missed target.
Gun No. 2	"	"	16.67	19.74	27.74	4 " " "
Gun No. 3	"	"	15.17	27.10	34.02	12 " " "
Gun No. 4	"	"	18.25	22.95	32.25	4 " " "
Gun No. 5	"	"	19.75	17.66	29.88	All hit "
Gun No. 8	"	"	21.62	17.16	31.81	20 per cent. missed "
Gun No. 9	"	"	25.05	15.45	31.91	4 " " "

Target practice at 500 yards.—Rifle "à tige."

No. of gun fired.	Size of target.	No. of shots fired.	Mean perpendicular deviation.	Mean horizontal deviation.	Mean absolute deviation.	Remarks.
	Feet.		Inches.	Inches.	Inches.	
Gun No. 1	8 by 16	25	17.04	40.10	45.6	20 per cent. missed target.
Gun No. 2	"	"	24.32	48.	56.6	12 " " "
Gun No. 3	"	"	18.30	26.68	35.3	24 " " "
Gun No. 4	"	"	25.33	14.95	31.5	52 " " "
Gun No. 5	"	"	22.26	18.85	31.9	12 " " "
Gun No. 8	"	"	22.05	27.22	38.7	20 " " "
Gun No. 9	"	"	21.43	13.76	28.2	20 " " "

TABLE No. 2.—*Target practice at 600 yards.—Rifle "à tige."*

No. of gun fired.	Size of target.		No. of shots fired.	Mean perpendicular deviation.	Mean horizontal deviation.	Mean absolute deviation.	Remarks.
	Feet.	Inches.					
Gun No. 1	8 by 16	25	18.03	43.78	51.3	28 per cent. missed target.	
Gun No. 2	"	"	23.51	50.32	58.54	40 " " "	
Gun No. 3	"	"	29.08	23.21	41.94	60 " " "	
Gun No. 4	"	"	28.64	38.55	48.84	40 " " "	
Gun No. 5	"	"	23.16	16.87	31.89	36 " " "	
Gun No. 8	"	"	21.85	40.75	52.75	36 " " "	
Gun No. 9	"	"	25.70	46.23	56.79	48 " " "	

Target practice at 880 yards (half mile).—Rifle "à tige."

No. of gun fired.	Size of target.		No. of shots fired.	Mean perpendicular deviation.	Mean horizontal deviation.	Mean absolute deviation.	Remarks.
	Feet.	Inches.					
Gun No. 1	30 by 15	50	46.48	41.12	69.38	22 per cent. missed target.	
Gun No. 3	"	50	38.29	35.92	57.29	18 " " "	

TABLE No. 3.—*Target practice with new bullet.—Rifle of musket calibre.*

(See Plate, fig. 3.)

No. of gun fired.	Size of target.		No. of shots fired.	Mean perpendicular deviation.	Mean horizontal deviation.	Mean absolute deviation.	Remarks.
	Distance to target.	Feet.					
Gun No. 3	Yards. 200	8 by 8	50	Inches. 6.41	Inches. 6.54	Inches. 11.61	Dec. 6, 1852.
Gun No. 3	200	8 by 8	50	8.56	7.04	12.35	Dec. 10, 1852.

TABLE NO. 4.—*Target practice with new compound bullet.—Rifle of musket calibre.*

(See Plate, fig. 5.)

No. of gun fired.	Distance to target.	Size of target.	No. of shots fired.	Mean perpendicular deviation.	Mean horizontal deviation.	Mean absolute deviation.	Remarks.
	Yards.	Feet.		Inches.	Inches.	Inches.	
Gun No. 3	200	8 by 8	50	6.54	6.84	10.95	Jan. 13, 1854.
Gun No. 3	200	"	50	6.68	5.59	9.90	" "

TABLE 5.—*Target practice with Regulation rifle.—Expanding bullet.—No patch.*

(See Plate, fig. 5.)

Distance to target.	Size of target.	No. of shots fired.	Mean perpendicular deviation.	Mean horizontal deviation.	Mean absolute deviation.	Remarks.
Yards.	Feet.		Inches.	Inches.	Inches.	
200	8 by 4	50	6.21	4.15	8.45	Feb'y 2, 1854.
200	"	75	5.82	5.32	8.60	" "

Weight of bullet - - - - - 310 grains.

Charge of powder, (musket) - - - - - 38 "

TABLE No. 6.—*Target practice with Regulation rifle.—Long expanding bullet.—No patch.*

(See Plate, fig. 6.)

Distance to target.	Size of target.	No. of shots fired.	Mean perpendicular deviation.	Mean horizontal deviation.	Mean absolute deviation.	Remarks.
Yards.	Feet.		Inches.	Inches.	Inches.	
150	8 by 8	25	4.63	3.93	6.46	{ February 14, 1854. 12 shots in bull's eye.
200	"	25	6.28	5.64	9.71	{ February 11, 1854. 5 shots in bull's eye.
300	"	25	10.72	10.76	16.75	{ February 11, 1854. 5 shots in bull's eye.
400	"	50	14.07	11.80	20.45	{ February 11, 1854. 5 shots in bull's eye.
450	"	25	16.64	10.03	21.63	{ March 8, 1854. 4 shots in bull's eye.

Weight of bullet - - - - - 400 grains.

Charge of powder, (musket) - - - - - 50 "

TABLE No. 7.—*Target practice at 300 yards.—Percussion musket.—Service charge.*

Size of target.	No. of shots fired.	Mean perpendicular deviation.	Mean horizontal deviation.	Mean absolute deviation.	Remarks.
Feet.		Inches.	Inches.	Inches.	
30 by 15	25	42.04	70.75	87.06	12 per cent. missed target.

TABLE No. 7.—*Target practice at 400 yards.—Percussion musket.*

Size of target.	No. of shots fired.	Mean perpendicular deviation.	Mean horizontal deviation.	Mean absolute deviation.	Remarks.
Feet.		Inches.	Inches.	Inches.	
30 by 15	25	51.90	51.50	68.20	80 per cent. missed target.

TABLE No. 8.—*Target practice with Regulation Rifle.—Regulation service cartridge.—Spherical bullets.*

	Distance to target.	Size of target.	No. of shots fired.	Mean perpendicular deviation.	Mean horizontal deviation.	Mean absolute deviation.	Remarks.
	Yards.	Feet.		Inches	Inches.	Inches	
Feb. 14, 1854	150	8 by 8	25	7.24	6.16	10.53	7 shots in bull's eye.
Feb. 3, 1854	200	"	25	12.13	13.27	19.67	{ 3 shots missed target. 1 shot in bull's eye.
Mar. 1, 1854	300	"	25	15.58	32.03	39.	{ 19 shots missed target. 76 per cent.

Target practice with Sharpe's carbine.—Table of Mean Deviations.—Target 8 by 8 feet.

Distance.	Number of shots.	Vertical.	Horizontal.	Absolute.	Shots missed target.	Date.
Yards.	Inches.	Inches.	Inches.	Inches.		
150	25	10.12	7.71	13.78	1	Feb. 14, 1854.
200	20	15.08	9.15	19.95	1	March 6, 1854.
300	20	23.96	7.94	27.29	4	March 9, 1854.

REMARKS.

The bullets are too large for the diameter of chamber of barrel. After being fired four or five rounds, it was found impossible to force the cartridge in, without bursting it and spilling the powder. The firing was continued by resorting to the expedient of separating the bullet from the cartridge, forcing it into the chamber with a stick, and afterwards pouring in the powder. The slide frequently became very difficult to move. When the arm was taken into the shop to be cleaned, after the firing was concluded, the slide could not be moved at all, until thoroughly soaked in oil, to soften the dirt around it. The paper of the cartridge is always left behind in the chamber after each shot, and is frequently on fire when the succeeding cartridge is inserted. To remove all likelihood of danger from this, the paper remaining in the chamber after each shot was removed before inserting another cartridge.

BALLS USED IN COL. HUGER'S EXPERIMENTS.

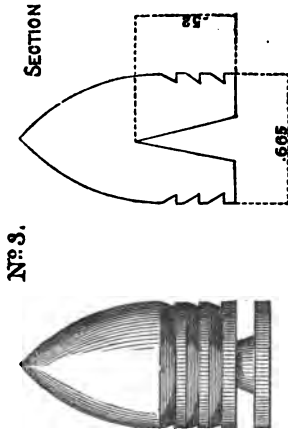

No. 3.

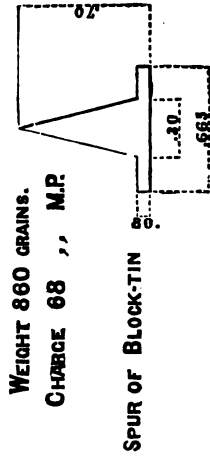
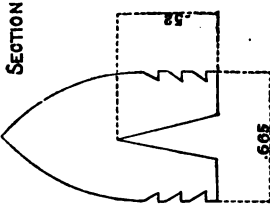

WEIGHT 860 GRAINS.
CHARGE 68 , M.P.

SPUR OF BLOCK-TIN

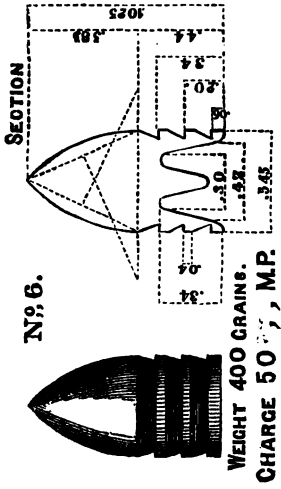
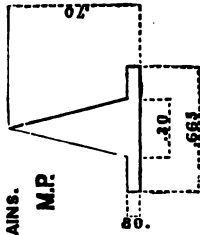

No. 6.

WEIGHT 400 GRAINS.
CHARGE 50 , M.P.

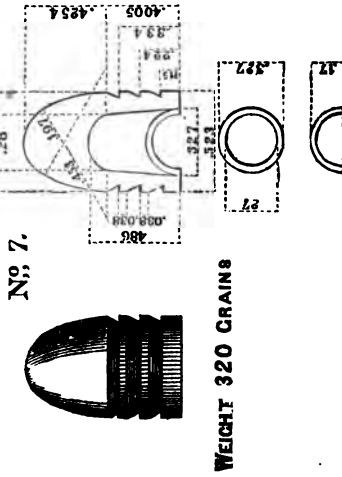
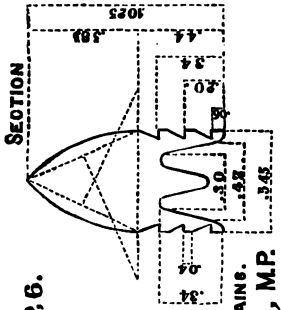

No. 7.

WEIGHT 320 GRAINS

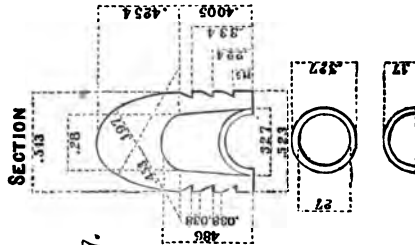

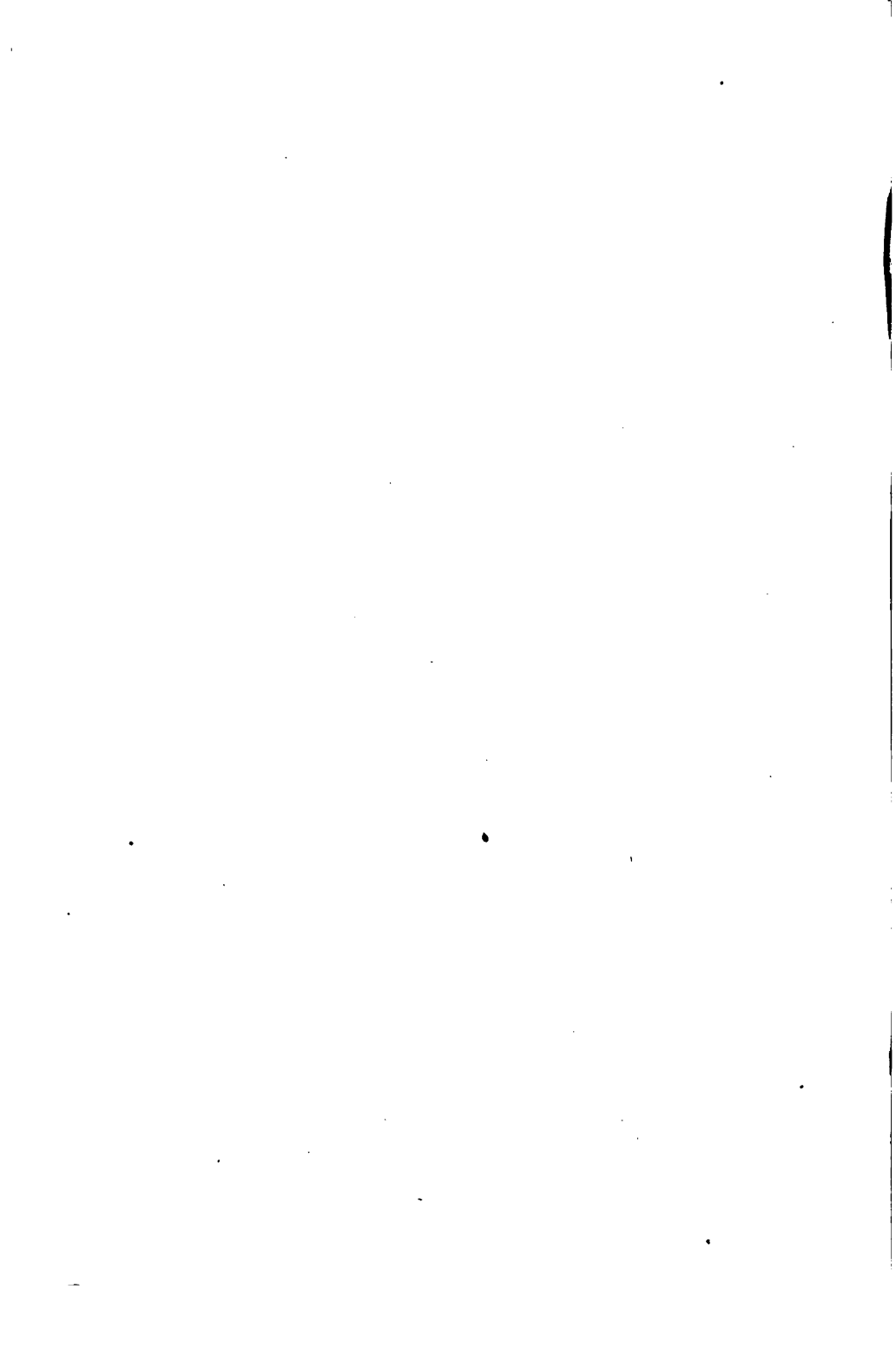

PART II.

EXPERIMENTS

WITH

THE REGULATION RIFLE, &c.,

MADE AT

THE HARPER'S FERRY ARMORY,

OCTOBER, 1854.

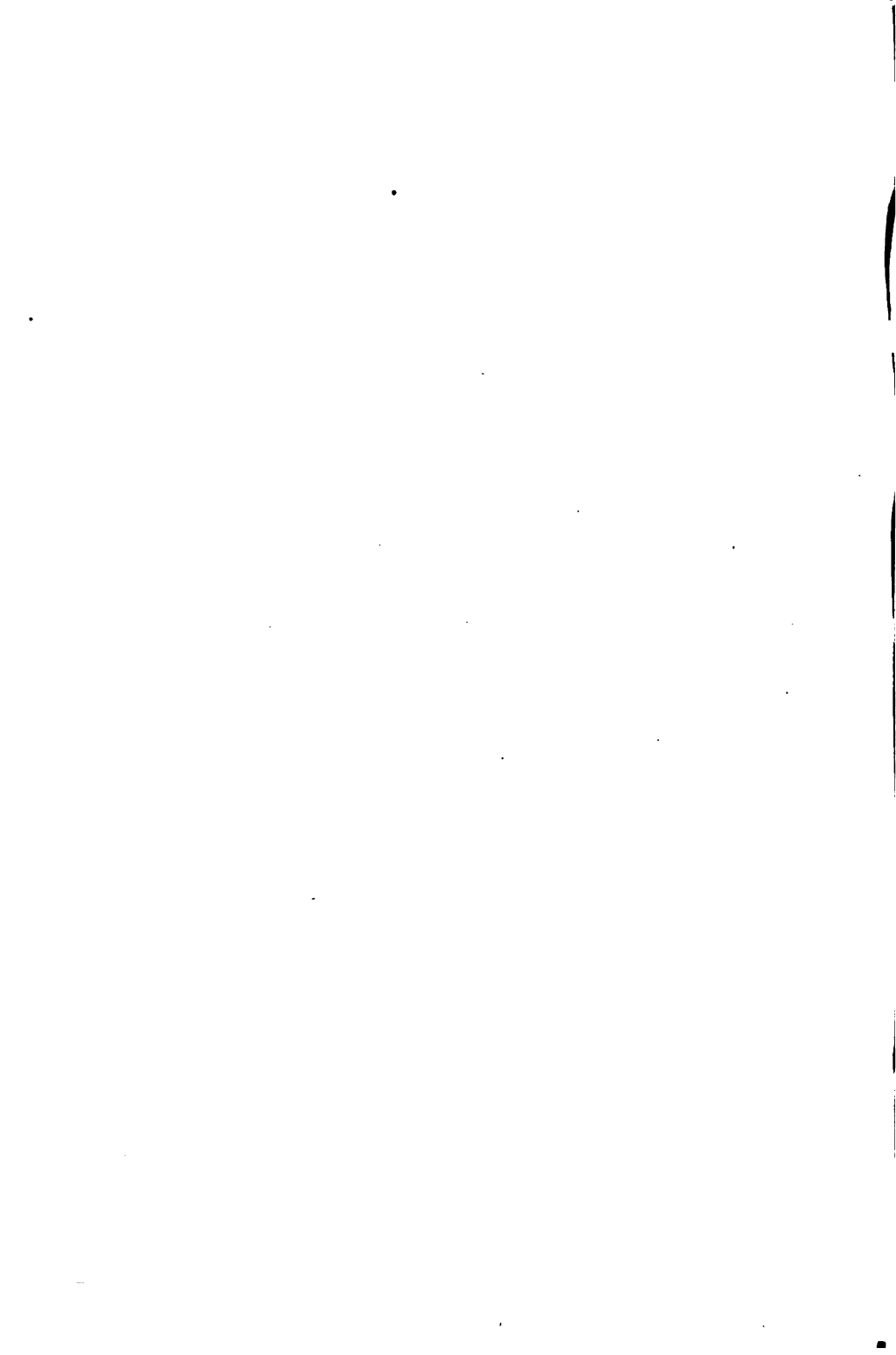

EXTRACT.

The annexed table of firings is taken from a report of a series of experiments made by Lieutenant J. G. Benton, Ordnance Department, at the Harper's Armory, in the month of October, 1854, for the purpose of determining the relative merits of certain projectiles for small arms, and the most suitable number of grooves for the regulation rifle.

The projectiles tried were the round ball, the elongated expanding ball, devised by Mr. Pritchett for the British service, and the French cylindro-ogee ball, converted into a self-expanding ball by Mr. Burton, master armorer at Harper's Ferry. A drawing, showing the shape of the elongated balls, and the grooves of the rifles, is appended.

With the exception of a few of the Pritchett balls, all the elongated were made to fit the bores of the guns very accurately, and were loaded without paper or patch of any kind. The few referred to had their diameters reduced sufficiently to admit of a patch of cartridge paper, in order that they might be tried as in the English service. The round balls were used with patches of cotton cloth; and all the balls were greased with a composition of beeswax and tallow.

Each gun was fired from a fixed rest, devised by Major Bell, of the Ordnance Department.

The size of the target (eight feet square) was not sufficient to catch all the balls, especially those fired at the greatest distances. As the mean deviations could not, therefore, be accurately determined, the per-centage of the number of

which hit the target at the various distances, is taken as a measure of the merits of the different guns and projectiles.

To render all the circumstances under which the firings were made, as uniform as possible, twenty of each of the different kinds of balls, were fired at the same target before removing the gun from the machine, and the bore of each barrel was carefully wiped out at every change of ball.

It will be seen from an examination of the following table, that, with one or two exceptions, the Harper's Ferry ball proved itself uniformly superior to the Pritchett ball reduced to the calibre of our present regulation rifle, (.54); and that the round ball was decidedly inferior to both. At 400 yards, the flight of the round ball was so wild that all further practice with it was suspended. In consequence of cutting away the lead around the cylindrical part of the Harper's Ferry ball, for the purpose of forming the grooves, the loading of this ball was found to be easier than that of the Pritchett ball. The grooves were also found to be very convenient for the purpose of holding the grease necessary to lubricate the bore of the barrel after each discharge.

Without determining the precise number of grooves most suitable for the regulation rifle, it is thought that the experiments demonstrated conclusively, that the number may be reduced from that at present in use, if the width of each groove be increased, and its depth diminished. Instead of *seven*, therefore, it is thought that either *three* or *five* grooves would answer a better purpose, provided that the lands and grooves be made of equal width. The gun designated as "5 grooves, No. 2," had very broad grooves and narrow lands—the latter being .02 inch in width. The practice with this gun was nearly as good as the best; but it is thought that the lands are too narrow and delicate for a service weapon. In consequence of the greater area of

the cross section of these grooves, the balls left the barrel more expanded than from the other guns, which produced a perceptible increase to the "drop" at long distances.

All the grooves tried were circular in shape, and of uniform depth from breech to muzzle.

To make the experiments with grooves more complete, trials should be made with barrels rifled, on the elliptical smooth-bored plan, as the simplicity of this plan strongly recommends it for the military service.

Three of the guns were fired upwards of a thousand times each, without producing any injurious effect whatever on the bore.

Musket powder was found to answer much better than the service rifle powder, even for the round balls. The latter not only failed to give as great accuracy as the former to the flight of the ball, but it frequently clogged the vent so effectually as to require a drift to be passed through it. Nothing of this kind ever occurred with the musket powder.

BALLS.

PRITCHETT.

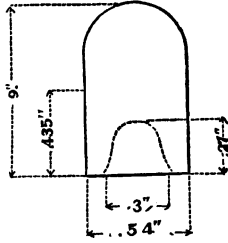

HARPER'S FERRY.

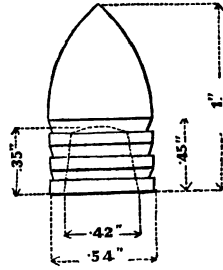

5 GROOVES.

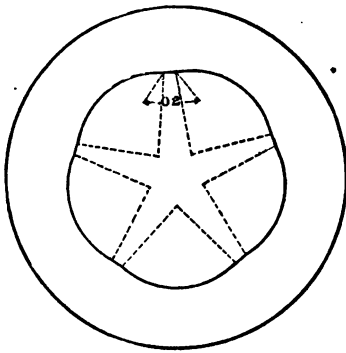

3 GROOVES.

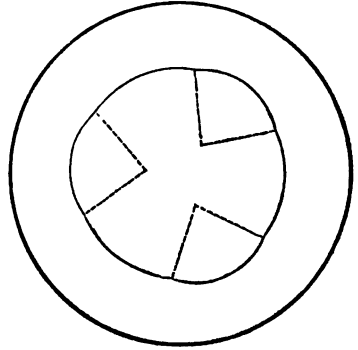
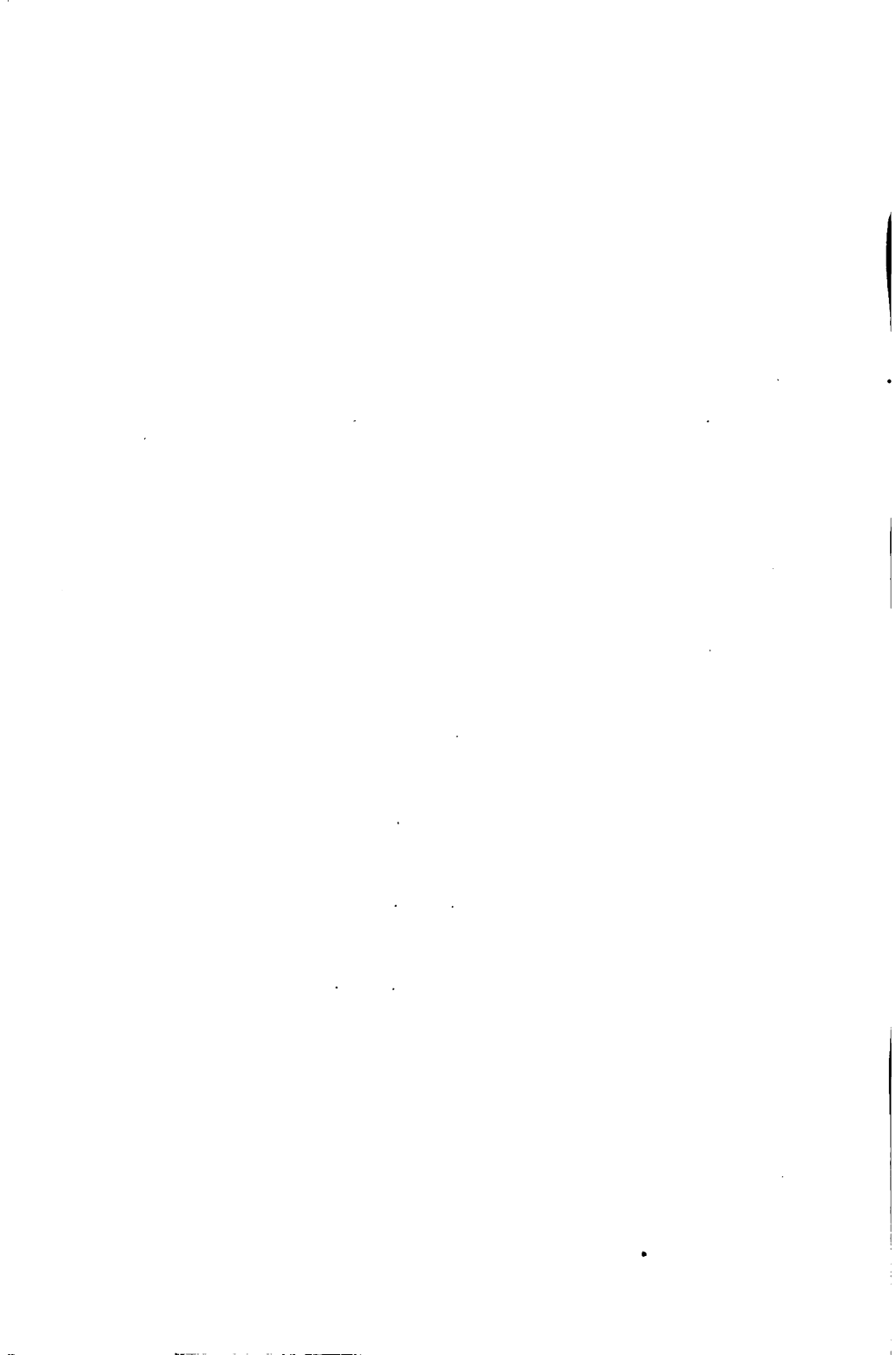

Table showing the per-centage of balls in a target eight feet square.
(Number of balls fired from each gun at each station, twenty.)

Depth of grooves.	Number of grooves.	Kind of ball.	200 yards.	300 yards.	400 yards.	500 yards.	600 yards.	700 yards.
.01 inch	7	Round75	.90	.45
		Pritchett...	.80	.85	.70	.50	.10	.25
		H. Ferry...	100	100	.90	.95	.45	.25
	5	Round90	.70	.35
		Pritchett...	100	.90	.70	.30	.45	.20
		H. Ferry...	.95	100	100	.75	.65	.45
	3	Round75	.70	.30
		Pritchett...	.95	.85	.55	.15	.05
		H. Ferry...	100	100	.90	.65	.60	.15
.015 inch.	7	Round85	.40	.20
		Pritchett...	100	.90	.70	.35	.30	.10
		H. Ferry...	.95	100	.90	.65	.60	.10
	5	Round95	.65	.35
		Pritchett...	100	.95	.80	.35	.30	.20
		H. Ferry...	100	100	.90	.95	.60	.35
	3	Round70	.25	.15
		Pritchett...	.85	.75	.30	.60	.10
		H. Ferry...	100	100	100	.90	.95	.65
.02 inch.	7	Round85	.45	.10
		Pritchett...	.95	.85	.85	.35	.30
		H. Ferry...	100	100	100	.70	.30	.05
	5	Round95	.50	.20
		Pritchett...	100	100	.90	.45	.50	.30
		H. Ferry...	100	100	100	100	.95	.55
	3	Round85	.65	.10
		Pritchett...	.95	.70	.70	.45	.30	.05
		H. Ferry...	100	100	100	.95	.75	.10
.015 in.	5, No. 2.	100	100	100	100	.85	.60
.02 in.	5, No. 2.	100	100	100	.85	.60	.20



PART III.

EXPERIMENTS WITH SMALL ARMS,

MADE AT

THE SPRINGFIELD ARMORY.

1855.

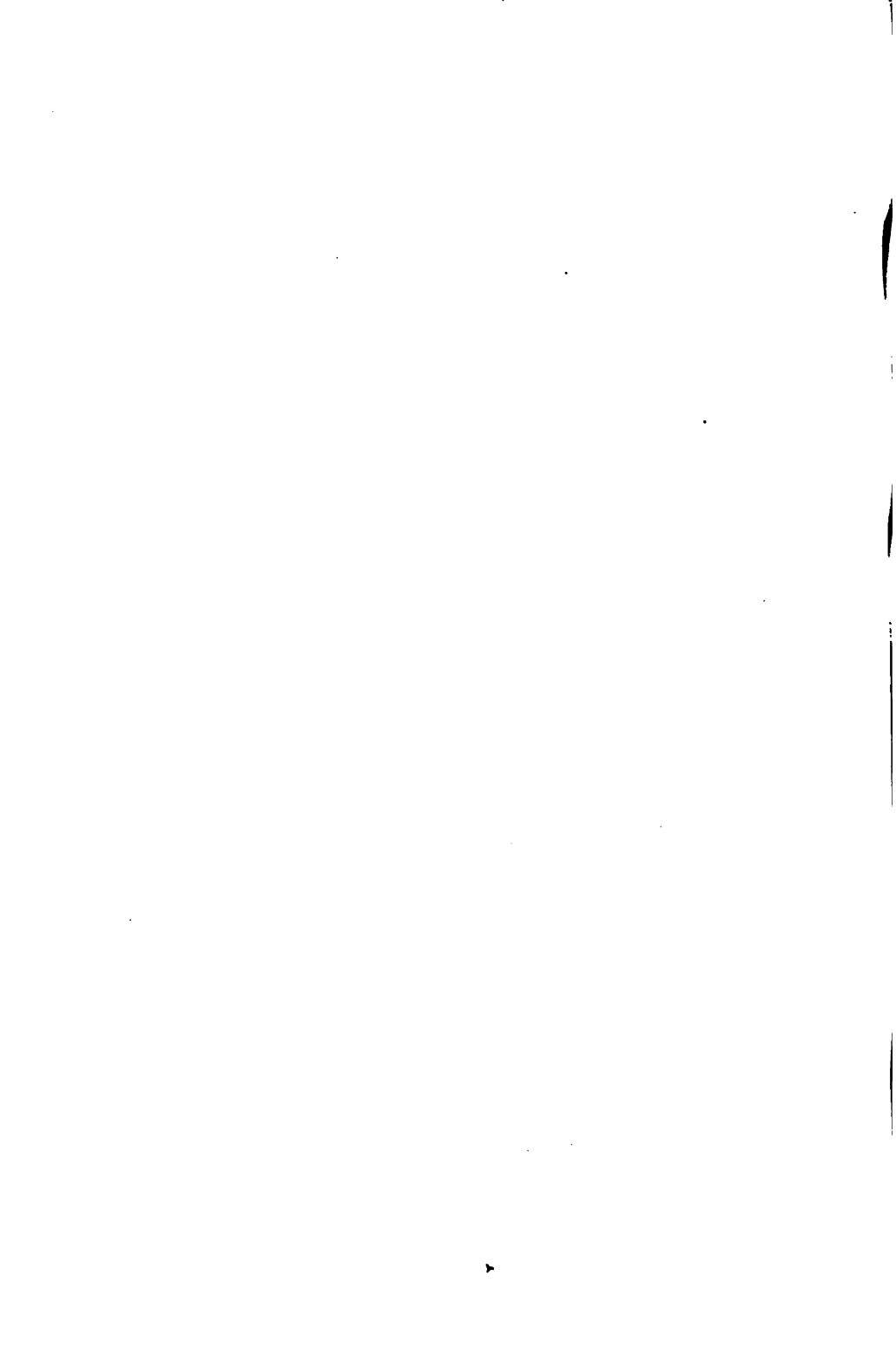

REPORT.

The following is a report of a series of experiments made at the Springfield Armory, during the spring of 1855, by Lieutenant J. G. Benton, agreeably to a programme drawn up by the Ordnance Board, under instructions from the Colonel of Ordnance.

Appended to this report, will be found tables showing the dimensions, weights, &c., of the new arms, together with a statement of the results obtained from extensive trials with them, during the fall of the present year. (See Part IV.)

The object of these experiments was to ascertain the most effective mode of applying the principles of the rifle, and the elongated expanding ball, to *all* the small arms of our military service; the experience of the French service, confirmed by experiments in our own, having shown that the application of these principles would be attended with very beneficial results.

The principal points of inquiry were :

1st. To determine the best mode of rifling the smooth bored arms already made.

2d. To ascertain if the present musket calibre (.69 in.) cannot be advantageously reduced for such arms as may be made hereafter.

3d. To ascertain if this reduced calibre cannot be made uniform for all small arms.

4th. To determine the best form of cavity for the Harper's Ferry ball.

To solve these points in a satisfactory manner, it was thought necessary to prepare for trial a variety of arms, differing in their calibres, and in the number, size, and shape of their grooves. A few barrels had been rifled by Mr. Buckland, the master machinist at Springfield, previously to the commencement of the experiments, which, with others that were prepared to carry out suggestions that arose during the progress of the experiments, increased the whole number tried considerably beyond the number originally proposed.

A detailed description of each gun will be found in the following tables.

DESCRIPTION OF TRIAL BARRELS.

(PERCUSSION MUSKET—MODEL 1842.)

Number.	Calibre.	Depth of grooves.		No. of grooves.	Twist, in feet.	Shape of grooves.	Remarks.
		Breech.	Muzzle.				
	In.	Inch.	Inch.				
1	.69	.015	.01	3	6	Circular.	Lands and grooves equal.
2	.69	.02	.01	3	6	Circular.	Lands and grooves equal.
3	.69	.015	.01	5	6	Circular.	Lands and grooves equal.
4	.69	.02	.01	5	6	Circular.	Lands and grooves equal.
5	.69	.015	.01	7	6	Circular.	Lands and grooves equal.
6	.69	.02	.01	7	6	Circular.	Lands and grooves equal.
7	.69	.0075	.0075	7	6	Rounded.	Lands .04 in. wider than grooves.
8	.69	.01	.01	3	6	Rounded.	Lands .12 in. wider than grooves.
9	.69	.01	.01	3	7	Rounded.	Lands .12 in. wider than grooves.
10	.69	.0075	.0075	7	7	Rounded.	Lands .03 in. wider than grooves.
11	.69	.01	.01	7	6	Circular.	Made at Harper's Ferry; lands and grooves equal.
12	.69	.015	.015	7	6	Rounded.	Lands .03 in. wider than grooves.
13	.69	.02	.005	5	6	Rounded.	Lands and grooves equal.
14	.69	.015	.005	5	6	Rounded.	Lands and grooves equal.
15	.69	.015	.005	3	6	Rounded.	Grooved with a five-groove cutter.
16	.69	.015	.005	3	6	Rounded.	Lands and grooves equal.
17	.69	.015	.005	3	8	Rounded.	Lands and grooves equal.
18	.69	.0175	.0175	7	0	Rounded.	Increasing twist, ending one turn in two feet. Lands .045 inch wider than grooves.
19	.69	.0125	.0125	7	0	Rounded.	Increasing twist, beginning with one turn in six feet, and ending with one turn in three ft. Lands .04 inch wider than grooves.

DESCRIPTION OF TRIAL BARRELS.
(NEW ARMS.)

Number.	Calibre.	Depth of grooves.		No. of grooves.	Twist, in feet.	Shape of grooves.	Remarks.
		Breech.	Muzzle.				
	Inch.	Inch.	Inch.				
Number 1.	1 .6	.015	.005	3	6	Rounded.	Lands and grooves equal.
	2 .6	.015	.005	3	6	Circular.	Do. do.
	3 .6	.015	.005	5	6	Rounded.	Do. do.
	4 .6	.015	.005	5	6	Circular.	Do. do.
	5 .6	.02	.01	3	6	Circular.	Do. do.
	6 .6	.02	.01	5	6	Circular.	Do. do.
Number 2.	1 .54	.015	.005	3	6	Circular.	Do. do.
	2 .54	.015	.005	3	6	Rounded.	Do. do.
	3 .54	.015	.005	5	6	Circular.	Do. do.
	4 .54	.015	.005	5	6	Rounded.	Do. do.
Carbine.	1 .54	.015	.005	3	6	Rounded.	Do. do.
	2 .54	.015	.005	3	6	Circular.	Do. do.
	3 .54	.015	.005	5	6	Rounded.	Do. do.
	4 .54	.015	.005	5	6	Circular.	Do. do.
Cadet	.54	.015	.005	3	6	Rounded.	Do. do.
Pistol.	1 .546	.0075	.005	3	6	Rounded.	8 inches in length. Lands and grooves equal.
	2 .546	.0075	.005	3	4	Rounded.	8 inches in length. Lands and grooves equal.
	3 .58	.0075	.005	3	4	Rounded.	10 inches in length. Lands and grooves equal.
	4 .58	.0075	.005	3	4	Rounded.	12 inches in length. Lands and grooves equal.

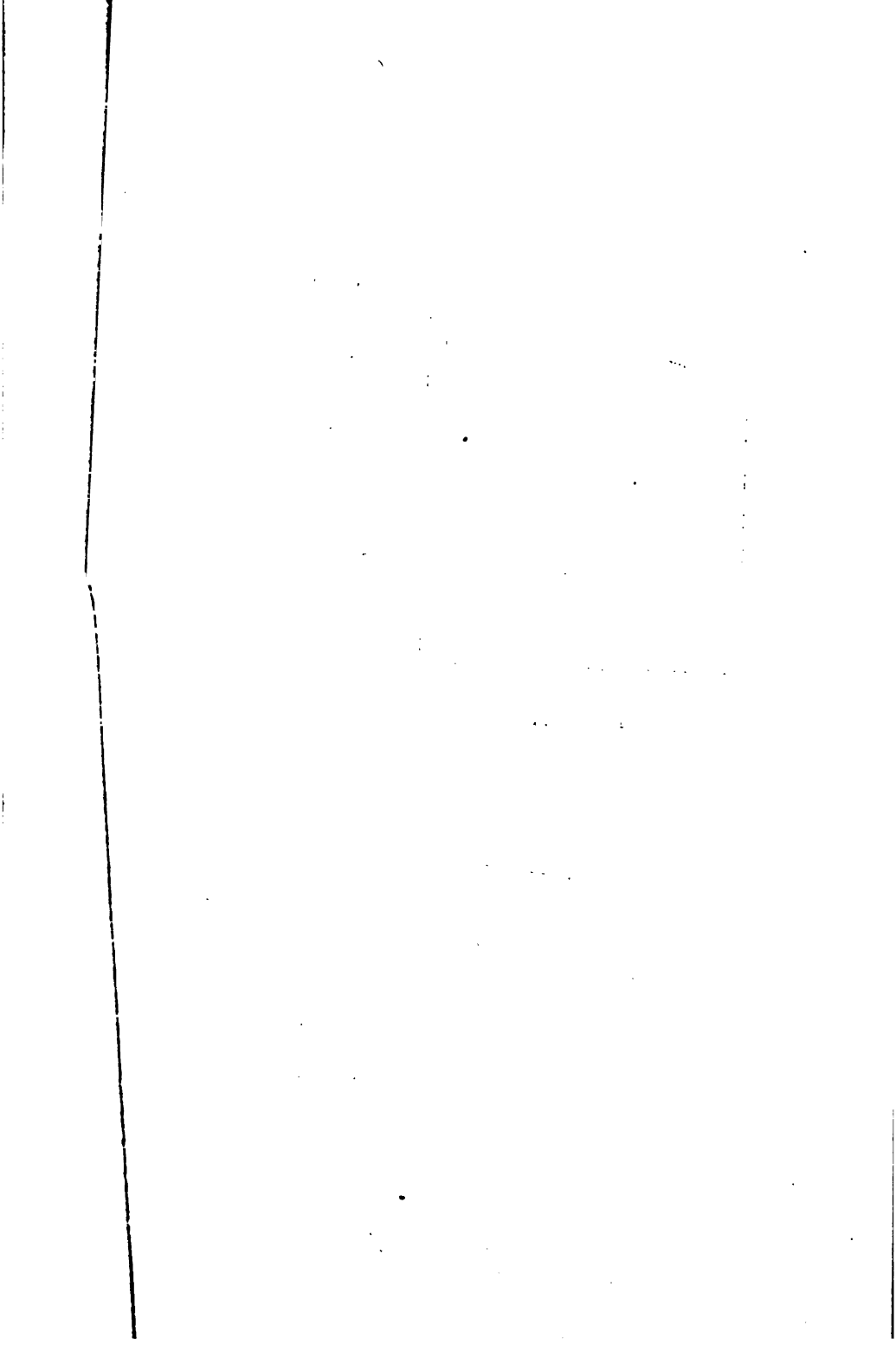

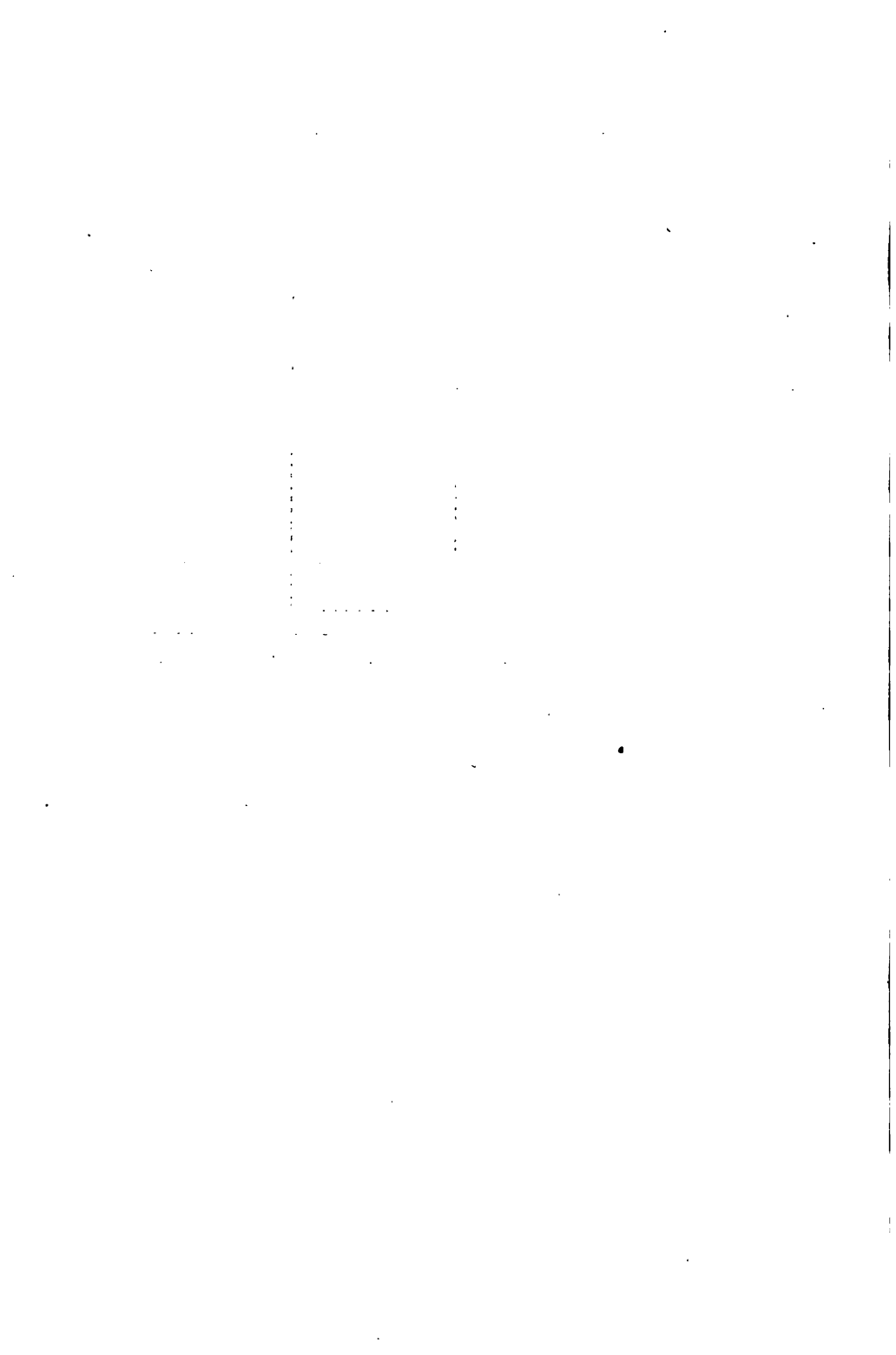

Table of weights and principal dimensions of trial barrels.

Arm.	Length.	Diameter of muzzle.	Diameter of breech.	Thickness of muzzle.	Thickness of breech.	Calibre.	Weight.
	Inch.	Inch.	Inch.	Inch.	Inch.	Inch.	Lbs.
Altered musket - - - - -	42	.843	1.25	.076	.28	.69	4.36
Trial gun No. 1 - - - - -	40	.843	1.25	.121	.32	.6	5.21
Trial gun No. 2 - - - - -	40	.78	1.1	.12	.28	.54	4.81
Trial carbine - - - - -	22	.75	1.1	.105	.28	.54	2.96
Cadet musket - - - - -	40	.71	1.1	.085	.28	.54	4.03
Pistol - - - - -	8	.82	1.	.14	.23	.546	1.03

NOTE.—The true calibre of the cadet musket in service is .57 inch.

Weights of finished arms, complete.

Arm.	Pounds.		Pounds.
Altered musket* - - - - -	10.87	Weight of old bayonet - - -	.68
Trial gun No. 1 - - - - -	11.19	Weight of new bayonet - - -	.78
Trial gun No. 2 - - - - -	9.75	Weight of sword bayonet - -	1.97
Trial carbine - - - - -	6.62	Rear sight (musket) - - - -	.12
Pistol - - - - -	2.73		

* The lock attached to the altered musket was self-priming.

PROJECTILE.

The balls used in the trials were simple in their structure—expanding by the direct action of the charge, in a cavity at the base.

The exterior shape was similar to that of the cylindro-ogee ball, with three grooves, or “cannelures,” as used in the French service. The superior merits of the simple expanding balls with grooves, over a large variety of other

balls, mostly compound in their structure, had been fully established by extensive experiments made at Harper's Ferry, in 1854.

The general rule observed was to load the balls without paper or patch of any kind. The composition of beeswax and tallow, with which the cylindrical portion of each ball was covered, was found under all circumstances of temperature, &c., sufficient to render the loading easy. Twenty-five rounds were usually fired before the barrel was cleaned. On one occasion, as many as two hundred shots were fired from the same gun without cleaning. In this case no trouble was found at any time in driving the ball to its place.

EXPANDING BALLS FOR RIFLE MUSKETS.

ALTERED MUSKET.

Heavy, wt. 730 grs.

Light, wt. 650 grs.

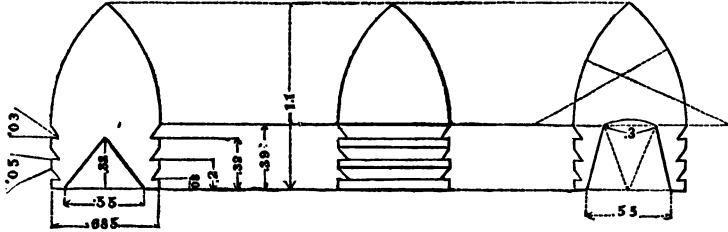

TRIAL GUN NO. 1.

Heavy, wt. 550 grs.

Light, wt. 500 grs.

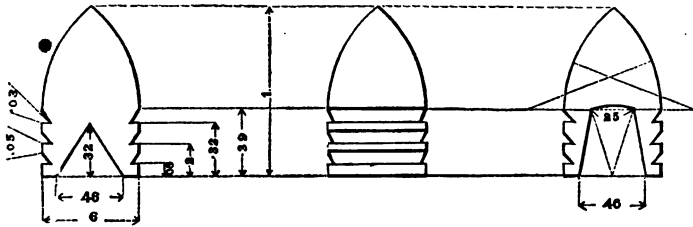

TRIAL GUN NO. 2.

Heavy, wt. 417 grs.

Light, wt. 390 grs.

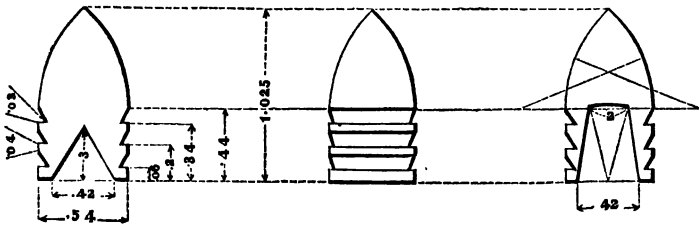

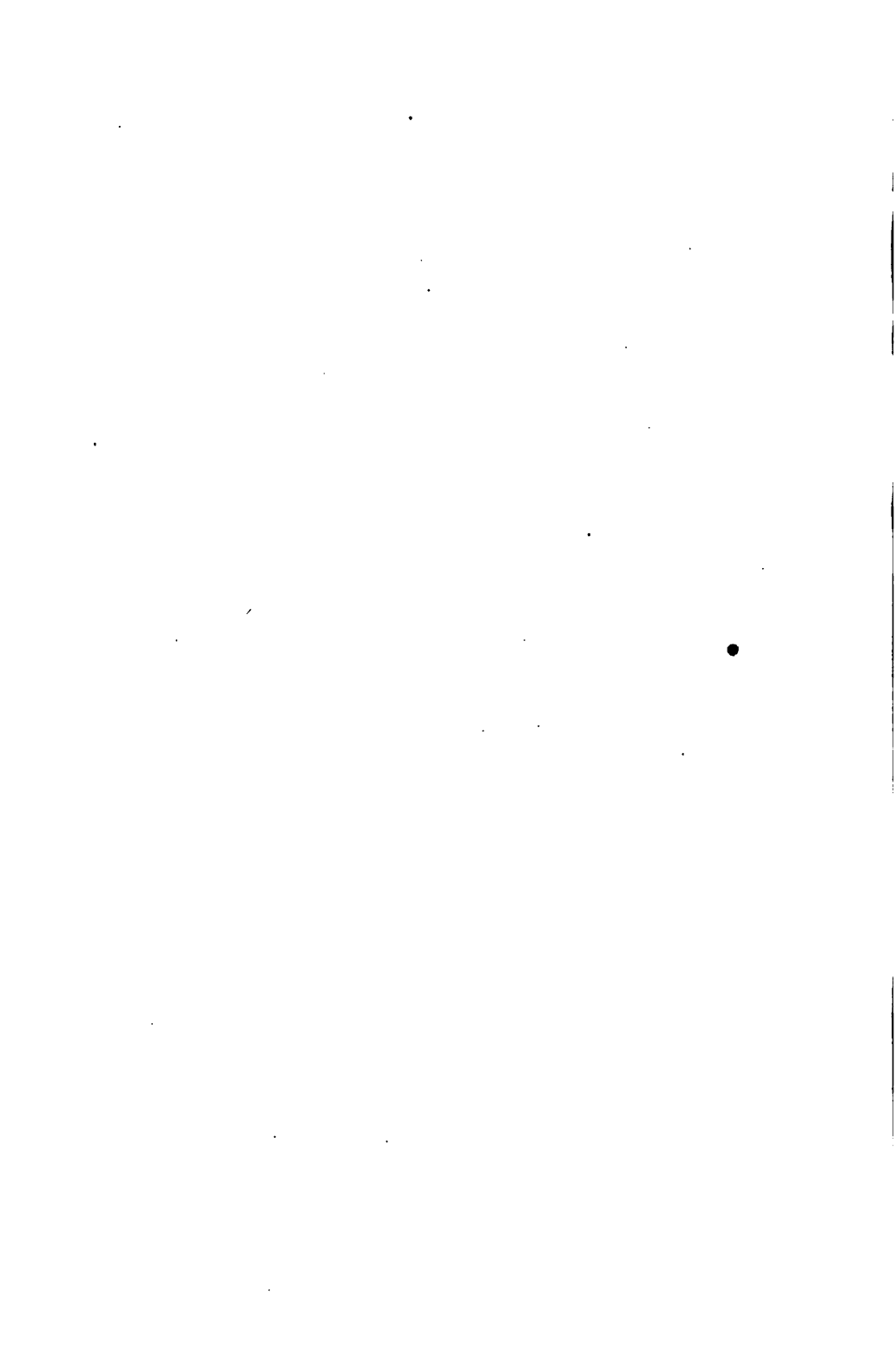

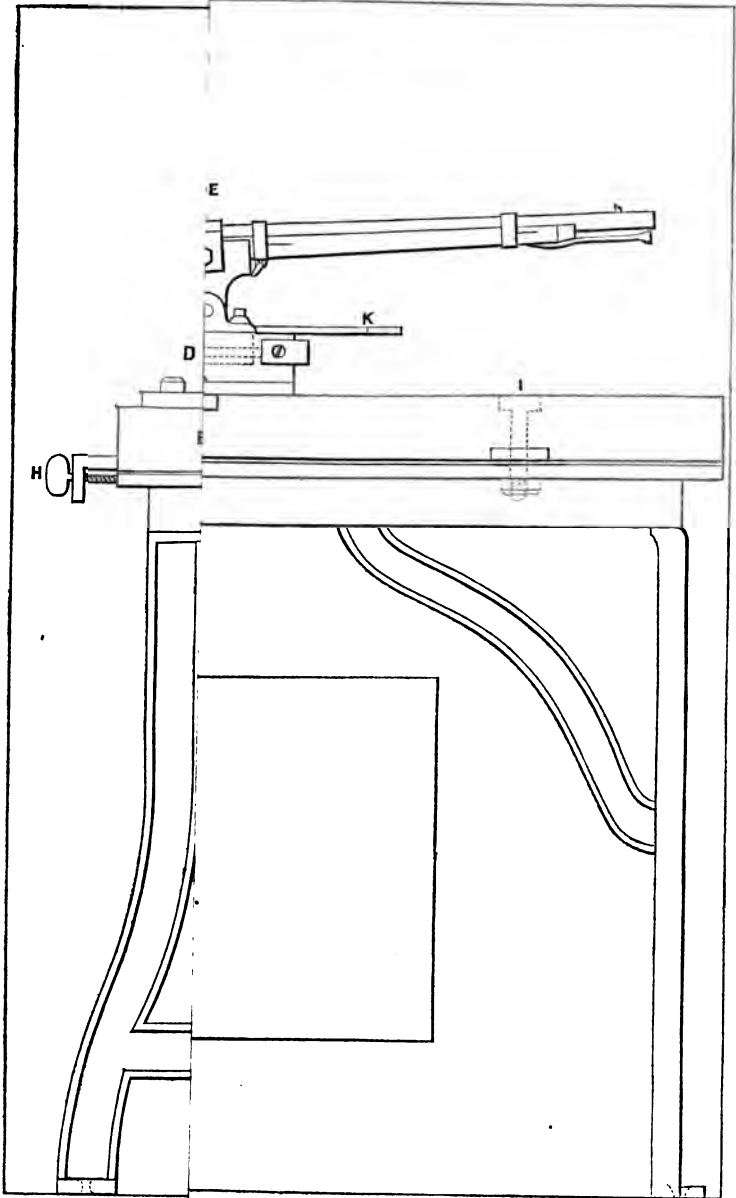

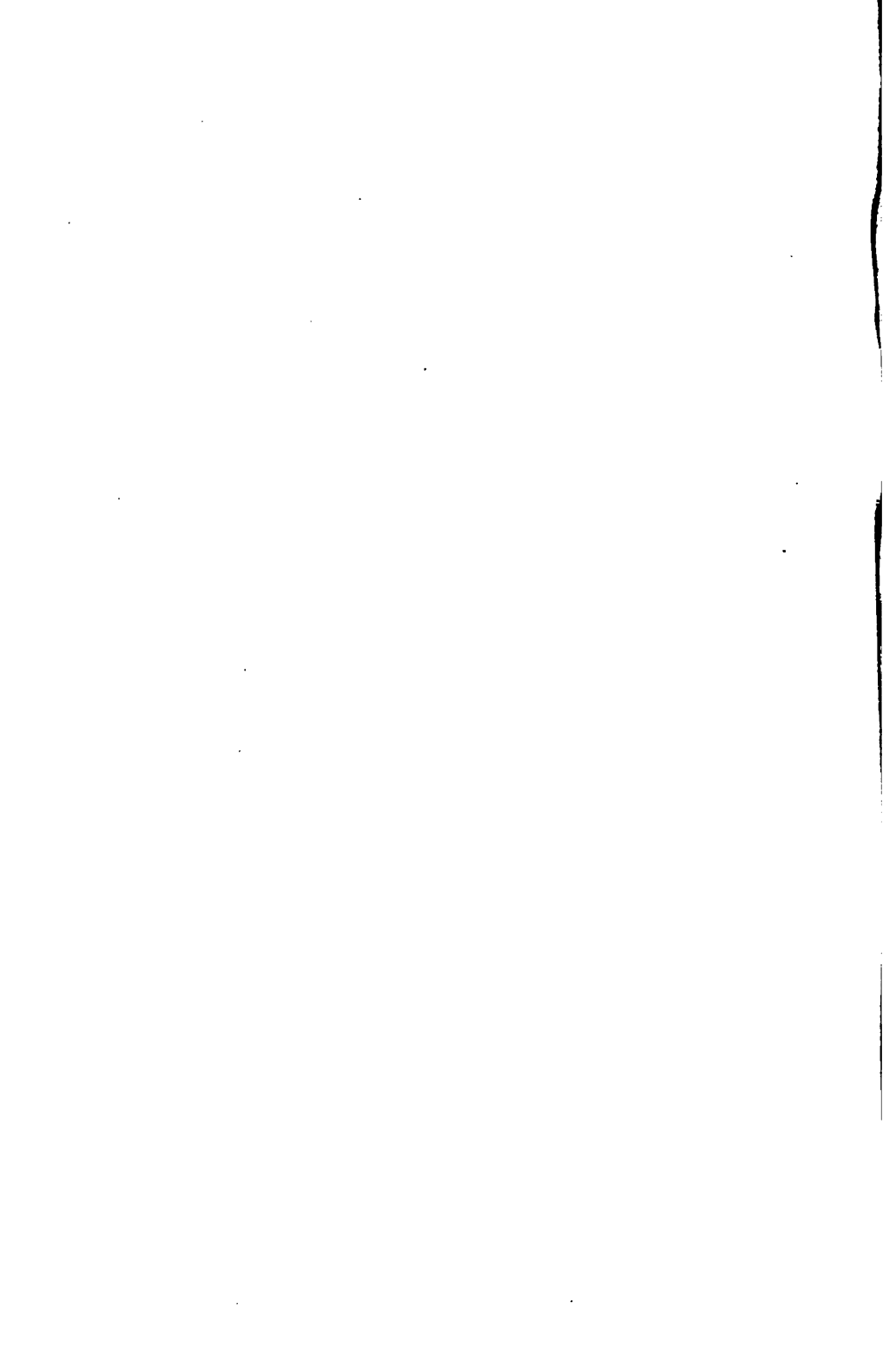

FIRING MACHINE.

To facilitate as much as possible the operations of loading, aiming, and firing, a machine was constructed to hold the barrels during the trials. The principal parts of this machine were a cast iron stand, a chassis, and a movable carriage. (See accompanying sketch.) The chassis (B) was composed of a stout piece of well-seasoned oak plank, and two cast iron guide pieces (D, D,) bolted to it. It was fastened to the stand by a pintle (I) around which it could be moved, and held firmly in any position required, by the two set screws (H, H.) The top carriage (C) was also made of cast iron, and so shaped as to receive the gun, and hold it firmly at the butt and near the middle band; at the butt by two screws (F F) let into the plate, and at the middle band by a strap and bolt, represented at (E.)

The top carriage was supported by two flanges projecting into grooves cut in, the whole length of the guide pieces, and by a slot cut in the head of the elevating screw (G) in such a way as to allow the carriage to be moved backwards and forwards—from, or to, battery.

To prevent the contraction of the oak plank from affecting the free motion of the movable carriage, two stout iron straps were let into the wood, cross-wise of the plank, and fastened by passing the guide-piece bolts through them.

After the machine had been leveled, it was screwed down to a heavy foundation of timber, embedded in the earth below the reach of the frost and other disturbing causes.

To load the piece (after it had been properly placed in the machine) the operator seized it by the small of the stock, drew it back as far as the stop (K) permitted, and then depressed the butt, when the muzzle was brought into the position to receive the charge.

To fire it, the operator raised the butt, pushed the carriage to battery, and pulled the trigger.

The muzzle was raised or depressed by means of the elevating screw (G) which had a clamp-nut attached, to secure it in any required position.

The angles were measured by a gunner's quadrant and spirit level. The long branch of the quadrant was shaped to fit the bore of the piece.

One man could load and fire, with ease and accuracy, a gun placed in this machine, at the rate of two shots per minute.

MANNER OF CONDUCTING TRIALS.

The manner of conducting the trials was to place each barrel, in succession, in the machine, and fire it a certain number of rounds, generally twenty-five, at targets placed at the distances of two hundred, five hundred, and one thousand yards, and record the measurement of each shot-hole from the centre of the target, or point aimed at. The merits of the different barrels were determined by comparing the *mean deviations* of each series of fires, first for the same distance, and then for the different distances, with each other.

To obtain these mean deviations with perfect accuracy, it became necessary to refer the position of each shot-hole from the centre of the target to the centre of impact as a new origin of co-ordinates. Besides the tables of mean deviation, there will be found others showing the position of the centre of impact of each series of fires. It is thought that these may be useful in considering the subject of *drift*, the effect of wind, and other atmospheric effects, on the general direction of the balls.

The targets were made of light wooden frames covered

with coarse cotton cloth, and were of the following dimensions, viz: 200 yards, 12 feet high, 16 feet long; 500 yards, 12 feet high, 24 feet long; 1,000 yards, 12 feet high and 32 feet long. The centre of each was on a level with the gun.

The services of three men were required at the target to perform its duties with celerity—one to measure, one to record, and one to patch up the shot-holes.

A copy of the record of a series of fires, and a sketch of the target, are appended for the purpose of showing, more fully, the method of keeping the record, and calculating the position of the centre of impact and mean vertical and horizontal deviations.

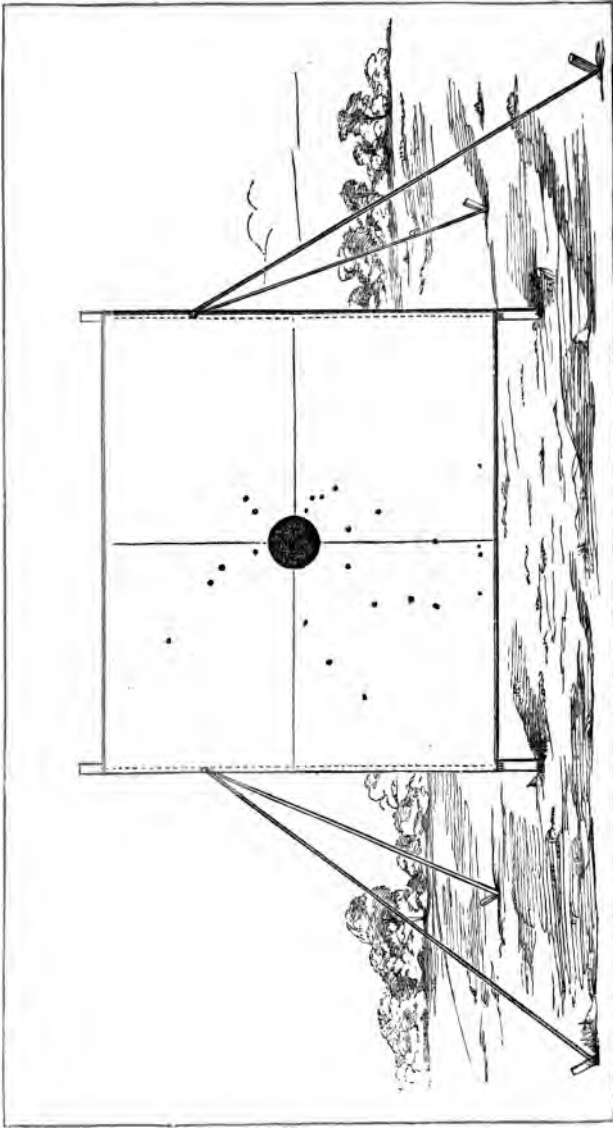

Size of target, 20 by 24 feet; distance, 1,000 yards. Number of shots in target, 24; whole number fired, 25.

TARGET RECORD. (Target 20 by 24 feet.)

New rifled musket; Nov. 15, 1855; 1000 yards; ball, 500 grs.; powder, 60 grs.; wind strong left.

No. shots.	Referred to centre of target.				Referred to centre of impact.				Remarks.
	Above.	Below.	Right.	Left.	Above.	Below.	Right.	Left.	
	Feet.	Feet.	Feet.	Feet.	Feet.	Feet.	Feet.	Feet.	
1	----	.5	1.3	----	2.6	----	2.4	----	One ball missed the target and struck the ground about 20 feet in front of it. Owing to the wind the piece was pointed to the left of the target.
2	----	.6	----	4.3	2.5	----	----	3.2	
3	----	1.8	----	6.4	1.3	----	----	5.3	
4	6.6	----	----	5.2	9.7	----	----	4.1	
5	----	4.4	----	3.3	----	1.3	----	2.2	
6	----	6.2	----	3.1	----	3.1	----	2.	
7	----	10.	----	.7	----	6.9	.4	----	
8	----	2.9	.5	----	.2	----	1.6	----	
9	----	7.5	----	3.5	----	4.4	----	2.4	
10	----	1.5	2.	----	1.6	----	3.1	----	
11	----	7.3	----	----	----	4.2	1.1	----	
12	----	10.	----	2.9	----	6.9	----	1.8	
13	----	3.1	----	1.3	----	----	----	.2	
14	----	4.	----	8.2	----	.9	----	7.1	
15	----	9.	.9	----	----	5.9	2.	----	
16	----	10.	3.9	----	----	6.9	5.	----	
17	----	1.3	2.	----	1.8	----	3.1	----	
18	----	2.2	2.7	----	.9	----	3.8	----	
19	1.9	----	1.4	----	5.	----	2.5	----	
20	2.3	----	----	2.1	5.4	----	----	1.	
21	----	4.7	1.3	----	----	1.6	2.4	----	
22	4.2	----	----	2.	7.3	----	----	.9	
23	1.7	----	----	.6	4.8	----	.5	----	
24	3.7	----	1.2	----	6.8	----	2.3	----	
25	----	10.	----	.6	----	6.9	.5	----	
	20.4	97.	17.2	44.2	49.9	49.	30.7	30.2	

Position centre of impact, 3.1 feet below. Mean vertical deviation . . . 47.5 in.
 1.1 feet left. Mean horizontal deviation . . . 29.1 in.

Table of co-ordinates of centres of impact for the altered muskets.

Distance, 200 yards; weight of powder, 70 grains; weight of ball, 658 grains;
diameter of ball, .685 inch.

No. of gun.	No. of shots.	Elevation.	Vertical distance.		Horizontal distance.		Date.	Weather, &c.
			Above.	Below.	Right.	Left.		
		° /	Inches.	Inches.	Inches.	Ins.		
1	25	----	14.3	----	5.	..	Mar. 19	Slight wind rear.
1	25	30	----	36.	13.2	..	Mar. 31	Wind left.
2	25	30	----	3.4	11.2	..	Mar. 19	Wind left.
2	25	30	----	19.2	3.6	..	Mar. 31	Strong wind right and rear.
3	25	30	----	26.	28.	..	Mar. 20	Strong wind left.
3	25	30	2.4	----	13.2	..	Mar. 31	Strong wind right and rear.
4	25	30	21.	----	18.	..	Mar. 16	Wind left.
4	25	20	----	38.	31.	..	Mar. 20	Strong wind left.
4	25	30	3.6	----	18.	..	Mar. 31	Calm.
5	25	25	----	21.3	29.	..	Mar. 21	Strong wind left.
6	25	30	----	1.5	26.7	..	Mar. 20	Strong wind left.
6	25	25	----	11.	20.	..	Mar. 15	Light wind left.
6	25	30	----	9.6	16.8	..	Mar. 31	Strong wind right and rear.
7	25	30	6.	----	20.	..	Mar. 21	Strong wind left.
7	25	30	----	21.6	16.8	..	Apl. 13	Light wind left.
8	25	30	10.4	----	4.	..	Mar. 19	Calm.
8	25	30	----	8.4	12.	..	Apl. 13	Light wind left.
9	25	30	6.5	----	18.	..	Mar. 19	Light wind left.
9	25	30	10.8	----	8.4	..	Apl. 13	Light wind left.
10	25	30	19.	----	11.	..	Mar. 19	Light wind left and rear.
10	25	30	----	1.2	18.	..	Apl. 13	Light wind left.

Table of co-ordinates of centres, &c.—Continued.

No. of gun.	No. of shots.	Elevation.	Vertical distance.		Horizontal distance.		Date.	Weather, &c.
			Above.	Below.	Right.	Left.		
		° /	Inches.	Inches.	Inches.	Ins.		
11	25	30	.6	2.4	..	Apl. 14	Calm.
12	25	30	10.2	4.5	Mar. 19	Calm.
12	25	40	7.2	26.4	..	Apl. 14	Calm.
13	25	15.6	30.	..	Mar. 26	Strong wind left.
13	25	45	26.4	9.6	..	Apl. 14	Calm.
14	25	30	7.2	27.6	..	Mar. 28	Strong wind left.
14	25	30	31.2	15.6	..	Mar. 31	Wind left.
15	25	30	1.2	12.	..	Mar. 31	Wind left.
15	25	30	6.	4.8	..	Apl. 14	Calm.
16	25	30	8.4	9.6	..	Mar. 31	Wind left.
16	25	30	19.2	20.8	..	Apl. 13	Light wind left.

Table of co-ordinates of centres of impact for the altered muskets.

Distance, 500 yards; weight of powder, 70 gra.; weight of ball, 658 gra.; diameter of ball, .685 in.

No. of gun.	No. of shots.	Elevation.	Vertical distance.		Horizontal distance.		Date.	Weather, &c.
			Above.	Below.	Right.	Left.		
		° /	Inches.	Inches.	Inches.	Inches.		
1	25	1 45	12.	74.4	Mar. 22	Light wind left.
1	25	1 45	42.6	133.2	Mar. 30	Strong wind left.
1	23	1 45	14.4	85.2	Apl. 6	Strong wind rear and left.
2	25	2	30.7	137.	Mar. 31	Strong wind left.
2	19	1 45	37.2	75.6	Apl. 6	Strong wind rear and left.

Table of co-ordinates of centres, &c.—Continued.

No. of gun.	No. of shots.	Elevation. ° /	Vertical distance.		Horizontal distance.		Date.	Weather, &c.
			Above.	Below.	Right.	Left.		
			Inches.	Inches.	Inches.	Inches.		
3	25	1 45	42.	98.4	Mar. 22	Light wind left.
3	25	1 40	58.8	136.8	Apl. 7	Strong wind left.
4	15	1 45	102.	Mar. 23	Strong wind rear.
4	20	1 45	3.6	132.	Apl. 7	Strong wind left.
5	23	1 55	8.4	113.	Mar. 22	Light wind left.
5	22	1 50	4.8	98.4	Apl. 7	Strong wind left.
5	25	1 45	25.2	32.4	Apl. 10	Calm.
6	24	16.8	80.4	Mar. 22	Light wind left.
6	22	1 50	34.8	138.	Apl. 7	Strong wind left.
6	25	1 45	4.8	56.4	Apl. 10	Calm.
7	26	1 45	27.6	44.4	Apl. 10	Calm.
7	25	1 45	67.2	120.	Apl. 7	Strong wind left.
8	25	1 45	27.6	84.	Apl. 10	Calm.
8	25	1 35	39.6	88.8	Apl. 7	Strong wind left.
9	25	1 45	13.2	34.6	Apl. 7	Strong wind rear.
9	25	1 40	1.5	102.	Mar. 23	Strong wind rear..
10	25	1 20	49.2	48.	Apl. 9	Strong wind rear.
10	25	1 45	7.2	43.2	Apl. 7	Strong wind rear.
11	23	1 30	15.3	9.6	Apl. 9	Strong wind rear.
11	25	1 45	14.4	16.8	Apl. 10	Strong wind rear.
12	25	1 45	36.	44.4	Apl. 10	Strong wind rear.
12	25	1 45	7.2	93.6	Apl. 13	Light wind left.
13	25	1 45	56.4	93.4	Apl. 13	Light wind left.
13	25	1 503	51.	Mar. 23	Strong wind rear.
14	23	1 45	22.8	96.	Apl. 6	Strong wind rear and left.
14	25	1 45	20.4	114.	Mar. 30	Strong wind left.
15	25	1 45	40.8	75.6	Apl. 13	Strong wind left.

Table of co-ordinates of centres, &c.—Continued.

No. of gun.	No. of shots.	Elevation. ° /	Vertical distance.		Horizontal distance.		Date.	Weather, &c.
			Above. Inches.	Below. Inches.	Right. Inches.	Left. Inches.		
15	25	1 45	60.	49.2	May 11	Strong wind left.
16	21	1 45	3.6	118.8	Apl. 6	Strong wind rear and left.
18	25	1 55	20.8	48.	Nov. 10	Calm.
19	25	2	7.2	67.	Nov. 10	Calm.
16	25	1 55	16.8	32.4	May 18	Strong wind front.
17	25	1 55	1.2	22.8	May 18	Strong wind front.

Table of co-ordinates of the centres of impact for the altered muskets.

Distance, 1000 yards; weight of powder, 70 grs; weight of ball, 658 grs.

No. of gun.	No. of shots.	Elevation. ° /	Vertical distance.		Horizontal distance.		Date.	Weather, &c.
			Above. Inches.	Below. Inches.	Right. Inches.	Left. Inches.		
1	25	4 45	24.	487.	Apl. 16	Wind left; 13 missed.
7	25	4 45	24.	590.	Apl. 16	Wind left; 13 missed.
14	25	4 45	30.	577.	Apl. 16	Wind left; 19 missed.
16	26	4 45	14.4	516.	Apl. 16	Wind left; 16 missed.
16	25	4 45	4.8	289.2	May 12	Strong wind rear; 16 missed.
17	25	4 45	3.6	228.	May 12	Strong wind rear; 13 missed.

The varying condition of the atmosphere, as regards temperature and moisture; the difficulty of expressing the exact direction and force of the wind during each series of fires; and the imperfections of the instrument for measuring the elevations, which only read to tenths of degrees, may

explain some of the discrepancies which appear in these tables, showing the positions of the centres of impact. As an instance of the variation of the centre of impact in a vertical direction, an altered Haper's Ferry rifle was fired, from a shoulder and rest, ten times, at each of the three distances of 100, 200, and 300 hundred yards, on two successive days. The first day was bright and clear, with a slight wind favoring the flight of the ball; the second was damp and slightly rainy, with scarcely any wind, either to favor or retard the ball. The result was, that with the same sights the centres of impact for the second day fell below their positions on the first, 6.4 inches for 100, 12.5 inches for 200, and 17.9 inches for 300 yards.

Less elevation of the barrel was required to send the ball a certain distance, when it was fired in the machine, than when it was fired from the shoulder. This was determined by taking the gun from the machine and firing it from the shoulder, and aiming at the same point with the same elevation of sight. It was found that at 300 yards the centre of impact would fall 2.5 feet, at 400 yards 3.5 feet, and at 500 yards about 4.5 feet. This was supposed to be due to the diminished recoil of the piece at the moment of explosion, arising from the weight of the machinery attached to it, and the consequent reaction upon the ball. A fixed rest should not, therefore, be used in determining the graduation of the sight of a piece intended to be fired from the shoulder.

Table of co-ordinates of centres of impact for new trial arms.

Distance 200 yards.

Guns.	No. of shots.	Elevation.	Vertical distance.		Horizontal distance.		Date.	Weather.	Weight of balls.	
			Above.	Below.	Right.	Left.				
No.		° /	Inches.	Inches.	Inches.	Inches.			Grains.	
Trial gun No. 1.	1	12	30	6.8	----	5.1	----	Apl. 16	Calm.	557
	1	13	30	19.2	----	8.4	----	Apl. 16	Calm.	500
	2	12	30	7.2	----	.6	----	Apl. 16	Calm.	557
	2	12	30	13.2	----	13.2	----	Apl. 16	Calm.	500
	3	25	30	----	12.	2.4	----	Apl. 16	Calm.	557
	4	25	30	----	.6	----	----	Apl. 16	Calm.	557
	1	25	30	----	9.6	----	2.4	Apl. 18	Calm.	557
	2	25	30	4.8	----	----	6.	Apl. 18	Calm.	557
Trial gun No. 2.	3	25	30	----	3.6	----	----	Apl. 18	Calm.	557
	4	24	30	----	8.4	----	----	Apl. 18	Calm.	557
	1	25	35	----	14.4	3.6	----	Apl. 21	Calm.	417
	2	25	40	----	14.4	----	4.8	Apl. 21	Calm.	417
	3	25	35	----	.7	----	7.2	Apl. 21	Calm.	417
	4	25	40	----	4.8	12.	----	Apl. 21	Calm.	417
	1	25	----	----	16.8	----	7.2	Apl. 24	} Strong wind right & rear.	517
	2	25	1	----	31.2	----	9.6	Apl. 24		517
3	25	1	----	34.8	----	3.6	Apl. 24	517		
4	25	1	----	27.6	----	2.4	Apl. 24	517		

Table of co-ordinates of centres of impact for the new trial arms.

Distance 500 yards.

Guns.	No. of shots.	Elevation.	Vertical distance.		Horizontal distance.		Date.	Weather, &c.	
			Above.	Below.	Right.	Left.			
	No.	° /	Inches.	Inches.	Inches.	Inches.			
Trial gun No. 1.	1	25	1 30	27.6	25.2	Apl. 17	Strong wind rear.
	2	25	1 30	6.	25.2	Apl. 17	Strong wind rear.
	3	25	1 30	1.2	25.2	Apl. 17	Strong wind rear.
	4	25	1 30	13.2	Apl. 17	Strong wind rear.
	1	25	1 50	24.	1.2	May 2	Wind variable.
	5	25	2	8.4	May 2	Wind variable.
Trial gun No. 2.	3	25	1 50	7.2	13.2	May 2	Wind variable.
	6	25	2	31.2	8.4	May 2	Wind variable.
	1	25	1 45	30.	33.6	Apl. 23	Slight wind right.
	2	25	1 45	2.4	30.	Apl. 23	Slight wind right.
	3	25	1 45	4.8	12.	Apl. 23	Slight wind right.
	4	25	1 45	1.2	6.	Apl. 23	Slight wind right.
Carbine.	1	25	1 45	15.6	14.4	May 11	Calm.
	2	25	1 45	26.4	25.2	May 11	Slight wind variable.
	3	25	1 30	6.	7.2	May 11	Slight wind variable.
	4	25	1 30	7.2	8.4	May 11	Slight wind variable.
Carbine.	1	25	2 05	55.7	May 7	Strong wind variable.
	2	25	2 20	24.	18.	May 7	Strong wind variable.
	3	25	2 20	24.4	38.4	May 7	Strong wind variable.
	4	25	2 20	2.4	28.8	May 7	Strong wind variable.

Table of co-ordinates of centres of impact for the new trial arms.

Distance 1000 yards.

Guns.	No. of shots.	Elevation.	Vertical distance:		Horizontal distance.		Date.	Weather, &c.	
			Above.	Below.	Right.	Left.			
No.		' °	Inches.	Inches.	Inches.	Inches.			
Trial gun No. 1.	1	16	4 20	9.6	132.	Apl. 18	Calm; 4 balls missed target.
	2	25	4 20	20.4	81.6	Apl. 18	Calm; 13 balls missed target.
	3	25	4 20	25.	Apl. 18	Calm; 16 balls missed target.
	4	25	4 20	18.	43.2	Apl. 18	Calm; 13 balls missed target.
	5	25	4 20	30.	276.	May 17	Strong wind left and front; 10 balls missed target.
	6	25	4 30	7.2	408.	May 17	Strong wind left and front; 9 balls missed target.
Trial gun No. 2.	1	25	4 20	10.8	115.2	May 11	Wind left; 11 balls missed target.
	2	24	4 40	9.6	30.	May 11	Calm; 9 balls missed target.
	3	25	4 10	30.	48.	May 11	Calm; 16 balls missed target.
	4	25	4 15	21.6	69.6	May 11	Calm; 16 balls missed target.
Carbine.	1	25	5 10	20.4	16.8	May 12	Strong wind rear; 15 balls missed target.
	2	25	5 10	16.8	79.2	May 12	Strong wind rear; 8 balls missed target.
	4	25	5 5	19.2	57.6	May 12	Strong wind rear; 11 balls missed target.
Cadet.	20	4 20	32.4	8.4	May 12	Strong wind rear; 11 balls missed target.	

Table of co-ordinates of centres of impact for the altered musket.

Distance 200 yards; weight of powder 70 grs.; weight of ball 600 grs.; diameter of ball .68 inch.

No. of gun.	No. of shots.	Elevation. ° /	Vertical distance.		Horizontal distance.		Date.	Weather, &c.
			Above. Inches.	Below. Inches.	Right. Inches.	Left. Inches.		
1	25	30	7.2	28.8	May 27	Strong wind left.
2	25	30	38.4	24.	May 27	Strong wind left.
3	25	30	14.4	28.8	May 27	Strong wind left.
4	25	30	14.4	24.	May 27	Strong wind left.
5	25	30	12.	28.8	May 27	Strong wind left.
6	25	30	36.	31.2	May 27	Strong wind left.
7	25	30	6.	24.	May 27	Strong wind left
14	25	30	16.8	27.6	May 27	Strong wind left.
Distance 500 yards; weight of powder 70 grs.; weight of ball 722 grs.; diameter of ball .685.								
1	25	1 40	6.	40.8	April 17	Strong wind rear.
7	25	1 40	7.2	12.	April 17	Strong wind rear.
14	25	1 40	8.4	39.6	April 17	Strong wind rear.
16	25	1 40	18.	16.8	April 17	Strong wind rear.

Table of co-ordinates of centres of impact for the altered musket.

Distances, 200, 500, and 1000 yards; weight of powder, 70 grs.; weight of ball, 756 grs.; diameter of ball, .69 inch.

No. of gun.	No. of shots.	Elevation.	Vertical distance.		Horizontal distance.		Date.	Weather, &c.
			Above.	Below.	Right.	Left.		
		° /	Inches.	Inches.	Inches.	Inches.		
7	25	30	18.	1.2	Apl. 19	Calm.
8	25	30	15.6	Apl. 19	Calm.
9	25	30	1.2	1.2	Apl. 19	Calm.
10	25	30	2.4	2.4	Apl. 19	Calm.
500 yards.								
7	25	1 40	39.6	30.	Apl. 19	Calm.
8	25	1 50	12.	51.6	Apl. 19	Calm; 3 missed.
9	25	1 45	31.2	Apl. 19	Calm.
10	25	1 45	31.2	14.4	Apl. 19	Calm.
1,000 yards.								
7	25	4 40	4.8	136.8	Apl. 23	Strong wind rear; 12 missed.
8	25	4 40	38.4	180.	Apl. 23	Strong wind rear; 12 missed.
9	25	4 40	15.6	144.	Apl. 23	Strong wind rear; 12 missed.
10	25	4 40	32.4	140.	Apl. 23	Strong wind rear; 17 missed.

Table of mean drift.

Distance.	.54 calibre.		.6 calibre.		.69 calibre.		Remarks.
	Ball417 grs. Powder.. 50 grs.		Ball.550 grs. Powder.. 60 grs.		Ball650 grs. Powder.. 70 grs.		
Yards)	No. of shots.	Inches to the right.	No. of shots.	Inches to the right.	No. of shots.	Inches to the right.	
200	100	.9	200	1.3	275	10.1	All the barrels were grooved from left to right, with a six- foot twist.
500	25	14.4	*100	22.2	100	54.3	
1,000	75	29.2	100	57.9	†100	562.	

* These shots were fired with a strong wind blowing towards the target.

† These shots were fired with a light wind blowing from the left of the target.

The above is taken from the foregoing tables of co-ordinates of the centres of impact, and, with the exceptions noted, embraces all the shots fired in calm weather. From this it will be seen that the "drift," or tendency of the ball to deviate from the plane of fire, is in the direction of the twist of the grooves, and increases with the inclination of the grooves, and the distance passed over by the ball.

It is not considered that the experiments were made under sufficiently favorable circumstances to enable us to verify, with accuracy, the laws which govern this peculiar deviation, but it is thought that they confirm the fact that a deviation, dependant on the normal rotation of the ball, does exist.

Table of mean deviations for the altered musket.

Distance, 200 yards; target, 12 by 16 feet.

No. of gun.	Vertical deviation.	Horizontal deviation.	No. of shots.	Shots missed.	Remarks.
	Inches.	Inches.			
16	5.1	5.1	50	----	Weight of powder, 70 gra. Weight of ball, 658 gra. Diameter of ball, .685 inch.
14	4.9	5.4	50	----	
1	8.9	5.8	50	----	
3	7.8	7.7	50	----	
2	8.7	8.3	50	----	
7	9.2	9.2	50	----	
12	11.8	9.2	50	----	
8	11.7	10.	50	----	
15	10.1	6.4	50	----	
4	7.1	9.	50	----	
10	7.6	9.	50	----	
13	11.6	12.1	50	1	
9	11.8	10.3	50	----	
11	9.	6.	25	----	
5	10.1	15.4	50	1	
6	10.4	9.7	50	1	

Table of mean deviations for the altered musket.

Distance, 500 yards; target, 12 by 24 feet.

No. of gun.	Vertical deviation.	Horizontal deviation.	No. of shots.	Shots missed.	Remarks.
	Inches.	Inches.			
16	16.	15.7	50	----	} Weight of powder, 70 gra. Weight of ball, 658 gra. Diameter of ball, .685 inch.
14	19.5	14.	50	----	
7	16.3	17.5	50	----	
2	19.3	15.4	50	----	
1	24.	17.7	50	----	
3	22.6	23.1	50	----	
8	19.7	22.7	50	----	
12	29.4	17.5	50	----	
11	23.4	19.8	50	2	
15	24.2	26.5	50	2	
10	24.2	16.5	50	3	
4	19.8	19.6	50	3	
5	17.4	17.	50	6	
9	22.3	24.9	50	7	
6	17.5	21.4	50	12	
13	28.3	25.3	50	3	

Table of mean deviations for the altered musket.

Distance, 1000 yards; target, 12 by 32 feet.

No. of gun.	Vertical distance.	Horizontal distance.	No. of shots.	Shots missed.	Remarks.
	Inches.	Inches.			
16	33.6	61.2	26	16	} Weight of powder, 70 grs. Weight of ball, 658 grs. Diameter of ball, .685 inch.
14	49.	14.4	25	19	
7	36.	36.	25	13	
1	27.6	55.2	25	13	

Nearly every shot that missed, either passed over or fell short of the target. The length of the target was more than sufficient to embrace all the side deviations of the balls.

Table of mean deviations for the new trial arms.

Distance, 200 yards; target, 12 by 16 feet.

Gun.	Barrel.	Vertical.	Horizontal.	No. of shots.	Shots missed.	Remarks.
		Inches.	Inches.			
No. 1 (.6)	No. 1	3.2	2.4	25	} Weight of powder, 60 grs. Weight of ball, 557 grs.
Do.	No. 2	4.8	3.	25	
Do.	No. 3	5.4	4.3	25	
Do.	No. 4	5.7	4.8	25	
Do.	No. 5	3.2	4.8	25	
Do.	No. 6	3.8	2.6	25	
No. 2 (.54)	No. 1	9.2	4.4	25	2	} Weight of powder, 50 grs. Weight of ball, 417 grs.
Do.	No. 2	2.7	2.8	25	
Do.	No. 3	3.6	3.7	25	
Do.	No. 4	5.5	4.8	25	
Carbine.	No. 1	9.9	9.6	25	} Weight of powder, 50 grs. Weight of ball, 390 grs.
Do.	No. 2	6.4	3.8	25	
Do.	No. 3	4.5	4.3	25	
Do.	No. 4	4.2	7.2	25	
Cadet bar'l	4.8	5.2	26	

Table of mean deviations for the new trial arms.

Distance, 500 yards; target, 12 by 24 feet.

Gun.	Barrel.	Vertical.	Horizontal.	No. of shots.	Shots missed.	Remarks.
		Inches.	Inches.			
No. 1 (.6)	No. 1	14.	12.9	25	----	} Weight of powder, 60 grs. Weight of ball, 557 grs.
Do.	No. 2	12.7	7.6	25	----	
Do.	No. 3	14.6	11.7	25	----	
Do.	No. 4	10.8	14.	25	----	
Do.	No. 5	13.2	9.6	25	----	
Do.	No. 6	20.4	6.3	25	----	
No. 2 (.54)	No. 1	14.4	7.3	25	2	} Weight of powder, 50 grs. Weight of ball, 417 grs.
Do.	No. 2	14.2	16.	25	----	
Do.	No. 3	14.5	10.3	25	----	
Do.	No. 4	17.5	14.4	25	----	
Carbine.	No. 1	11.7	15.8	25	----	} Weight of powder, 50 grs. Weight of ball, 390 grs.
Do.	No. 2	20.6	13.8	25	----	
Do.	No. 3	18.4	18.9	25	----	
Do.	No. 4	14.2	19.2	25	----	
Cadet bar'l	13.5	12.9	25	----	

Table of mean deviations for the new trial arms.

Distance, 1000 yards; target, 12 by 32 feet.

Guns.	Barrel.	Vertical.	Horizontal.		No. of shots.	Shots missed.	Remarks.
		Inches.	Inches.				
No. 1 (6)	No. 1	24.	36.	*24	25	10	} Weight of powder, 60 grains. Weight of ball, 557 grains.
Do.	No. 2	33.5	24.	..	25	13	
Do.	No. 3	26.4	16.8	..	25	16	
Do.	No. 4	36.	24.	..	25	13	
Do.	No. 5	38.4	51.6	24	25	9	
Do.	No. 6	36.	66.	13	25	17	
No. 2 (.54)	No. 1	24.	42.	20	25	11	} Weight of powder, 50 grains. Weight of ball, 417 grains.
Do.	No. 2	45.6	20.4	16	24	9	
Do.	No. 3	20.4	33.6	13	25	16	
Do.	No. 4	46.8	31.2	13	25	16	
Carbine.	No. 1	45.6	68.4	17	25	15	} Weight of powder, 50 grains. Weight of ball, 390 grains.
Do.	No. 2	43.2	55.2	20	25	8	
Do.	No. 4	40.8	43.2	16	25	11	
Cadet bar'l	30.	20.4	11	20	11	

*The numbers in this column include the shots that struck the ground in front, as well as those that struck the target. The horizontal deviations of these shots were measured, and are included in the column of "mean deviations." This will explain why the mean horizontal deviations are found, in some instances, to be greater than the corresponding vertical ones. As a general rule the latter deviations were found to increase with the distance much faster than the former.

DEVIATIONS OF DIFFERENT ARMS.

The three following tables are given for the purpose of comparing the results with the trial arms with the results obtained from the new arms lately introduced into the English and French services. The figures placed opposite the different trial arms represent the mean of the deviations of all the different arms of each kind. The English musket was fired from the machine at the same time, and under the same circumstances, as the trial carbines.

For information concerning the mode of firing the French arms, see Extracts from the work of L. Panôt, appended to the report of Col. Huger's experiments, from which the deviations are taken.

Table of mean deviations for different arms.

Distance, 200 yards; target, 12 by 16 feet.

Guns.	Vertical.	Horizontal.	No. of shots.	Shots missed	Remarks.
	In.	In.			
Trial gun No. 1 - - - - -	4.8	4.5	100	.	Ball, 557 grs. ; powder, 60 grs.
Trial gun No. 2 - - - - -	5.2	3.9	100	.	Ball, 417 grs. ; powder, 50 grs.
Trial carbine - - - - -	6.2	6.2	100	.	Ball, 390 grs. ; powder, 50 grs.
Altered musket - - - - -	6.6	5.8	100	.	Ball, 650 grs. ; powder, 70 grs.
Cadet musket - - - - -	4.8	5.2	25	.	Ball, 417 grs. ; powder, 50 grs.
Enfield musket (English)	7.	11.3	25	.	Pritchett ball ; powder, 60 grs.
Carabine à tige - - - - -	6.7	6.3	}	..	See Panôt.
Musket à tige (French)	8.	7.6			
Swiss rifle (Basle) - - -	5.3	4.3	10	.	

The Swiss rifle was fired with ammunition furnished by the maker, and without the aid of the fixed rest. All the other guns were fired from a fixed rest.

Table of mean deviations for different guns.

Distance 500 yards; target 12 by 24 feet.

Guns.	Vertical.	Horizontal.	No. of shots.	Shots missed.	Remarks.
	Inches.	Inches.			
Trial gun, No. 1	13.	11.5	100	Ball 557 grs.; powder 60 grs.
Trial gun, No. 2	15.	12.	100	Ball 417 grs.; powder 50 grs.
Trial carbine ...	16.2	16.9	100	Ball 390 grs.; powder 50 grs.
Altered musket.	20.5	17.6	100	Ball 650 grs.; powder 70 grs.
Cadet musket...	13.5	12.9	25	Ball 417 grs.; powder 50 grs.
Enfield musket..	20.4	19.2	25	Ball 530 grs.; powder 60 grs.
Carbine á tige..	15.7	14.9	See Panôt.
Musket á tige...	18.5	17.1			

* *[Table of mean deviations for different guns.*

Distance 1000 yards; target 12 by 32 feet.

Guns.	Vertical.	Horizontal.	No. of shots.	Shots missed.	Remarks.
	Inches.	Inches.			
Trial gun, No. 1	31.5	20.1	100	50	Ball 550 grs.; powder 60 grs.
Trial gun, No. 2	34.2	31.8	100	52	Ball 417 grs.; powder 50 grs.
Trial carbine...	43.2	55.6	75	34	Ball 390 grs.; powder 50 grs.
Altered musket.	36.5	49.2	100	61	Ball 650 grs.; powder 70 grs.
Cadet musket...	30.	20.4	20	11	Ball 417 grs.; powder 50 grs.
Enfield musket..	42.	52.8	25	10	Ball 530 grs.; powder 60 grs.
Carabine á tige.	59.5	37.4	} See Distance 874 yards } Panôt.
Musket á tige...	47.2	37.4	

CAVALRY PISTOL.

The first attempt to use the elongated expanding ball in a rifled cavalry pistol was unsuccessful, owing to the windage of the ball and the mode of rifling with broad grooves of uniform depth, leaving very narrow lands. These conditions seemed to require more expansion of the ball than the reduced charge could communicate to it, to enable it to take hold on the grooves, and receive from them the rotary motion necessary to make it go point foremost.

As the construction of the firing machine did not allow of the use of barrels of this size, they were all fired from a shoulder and rest.

Table of mean deviations for the cavalry pistol fired from the shoulder and at a rest.

Powder 30 grains.—Ball 390 grains.

Barrel.	Vertical.	Horizontal.	No of shots.	Shots missed.	Distance.	Target.
	Inches.	Inches.			Yards.	
No. 1	6.4	4.3	25	----	100	Target 8 by 8 feet.
No. 2	4.5	2.6	26	----	100	do do
No. 1	12.	12.	25	----	200	do do
No. 2	12.	5.7	25	----	200	do do
No. 2	25.2	13.2	25	----	300	do do
No. 2	33.6	22.8	23	5	400	Target 12 by 24 feet.
No. 2	31.2	21.6	16	5	500	do do

The superiority of the 4 feet over the 6 feet twist, as shown in barrels Nos. 1 and 2, for the distances of 100 and 200 yards, was so great, that all further practice with barrel No. 1 was suspended.

INCREASING TWIST.

Table of mean deviations obtained from barrels grooved with uniform and increasing twists.

Target, 16 by 24 feet.

Gun.	Distance.	Mean deviations		No. of shots.	No. of shots missed.	Remarks.
		Vertical.	Horizontal.			
	Yards.	Inches.	Inches.			
No. 16	200	5.7	4.7	50	} Weight of ball, 720 grs. Weight of powder, 70 grs.
No. 18	200	7.2	5.	25	2	
No. 19	200	19.2	13.2	25	
No. 16	500	13.8	13.2	50	
No. 18	500	27.6	25.2	25	4	
No. 19	500	32.4	19.2	25	2	

Barrels No. 18 and No. 19 were rifled at a private establishment. Their inferior execution, as compared to No. 16, is thought to be mainly due to the narrow size, and the too great terminal twist of their grooves. Owing to these defects, the grooves became so foul, after a few fires, as to exert but little influence on the balls. This was shown by the irregular flight, and the appearance of the surfaces of the balls after they had been fired. From 10 to 15 minutes more elevation was required to attain the same distance with these two barrels than with those with a regular 6 feet twist.

For these reasons it is not considered that these barrels offer fair examples of the principle of the increasing twist.

BALLS OF DIFFERENT SIZES AND WEIGHTS.

Table of results with balls of different sizes and weights for the altered musket and trial gun No. 1.

Distance, 200 yards; target, 12 by 16 feet. Distance, 500 yards; target, 12 by 24 feet.

Diameter of balls.	Weight of balls.	Distance.	Mean deviations.		No. of shots fired.	No. of shots missed.	Guns used in the trials.
			Vertical.	Horizontal.			
Inch.	Grains.	Yards.	Inches.	Inches.			
.69	752	200	4.7	4.7	100	----	7, 8, 9, 10.
.685	658	200	8.5	9.	100	----	7, 8, 9, 10.
.69	752	500	15.5	15.9	100	*3	7, 8, 9, 10.
.685	658	500	18.4	18.3	100	----	7, 8, 9, 10.
.685	658	200	8.1	9.2	175	----	1, 2, 3, 4, 5, 6, 7.
.68	593	200	9.4	8.9	175	2	1, 2, 3, 4, 5, 6, 7.
.685	720	500	16.2	16.1	100	----	1, 7, 14, 16.
.685	658	500	19.5	15.2	100	----	1, 7, 14, 16.
.595	557	200	3.8	2.4	25	----	1, 2 (.6).
.595	503	200	4.6	6.4	25	----	1 2 (6).

* Missed from gun No. 8.

Table showing the results obtained by lengthening the cylindrical part of the .54 inch calibre ball, and giving it four instead of three grooves.

No. of grooves.	Dis- tance.	Vertical deviation.	Horizontal deviation.	No. of shots.	No. missed.	Weight of—
	Yards.	Inches.	Inches.			
3 grooves	200	5.2	3.9	100	..	Ball 417 grs.; powder 50 grs.
4 grooves	200	6.2	5.1	100	..	Ball 517 grs.; powder 50 grs.
3 grooves	500	15.	12.	100	..	Ball 417 grs.; powder 50 grs.
4 grooves	500	18.9	16.2	100	13	Ball 517 grs.; powder 60 grs.

The two foregoing tables show that the windage of the ball should be reduced as much as possible, consistent with a proper facility of loading; and that the cavity should be no larger than is necessary to give sufficient expansion to cause it to take a firm hold on the grooves of the barrel. It would also appear that lengthening, or altering the proportions, of the present shaped ball would result in a loss of accuracy, especially if it be fired from guns of the service calibre, and rifled with a six-foot twist.

PENETRATIONS.

Table of penetrations in a target made of seasoned white pine boards one inch thick, and placed one and a half inches apart.

Guns.	Distance.	Weight of powder.	Weight of ball.	Diameter of ball.	No. of boards.
	Yards.	Grains.	Grains.	Inch.	
Trial gun No. 1 -----	60	557	.6	13½
Trial gun No. 2 -----	50	390	.54	11½
Altered musket -----	70	658	.685	11½
Do do -----	70	722	.685	12
Do do -----	70	756	.69	13
Trial carbine -----	50	390	.54	..
Trial pistol -----	30	390	.546	6½
Trial gun No. 1 -----	100	60	557	.6	11
Trial gun No. 2 -----	100	50	390	.54	9½
Altered musket -----	100	70	658	.685	10
Do do -----	100	70	722	.685	11
Do do -----	100	70	756	.69	12
Trial carbine -----	100	50	390	.54	9½
Trial pistol -----	100	30	390	.546	4½
Do do -----	200	30	390	.546	4
Do do -----	300	30	390	.546	3½
Do do -----	400	30	390	.546	3¼
Do do -----	500	30	390	.546	1½

Table of penetrations.—Continued.

Guns.	Distance.	Weight of powder.	Weight of ball.	Diameter of ball.	No. of boards.
	Yards.	Grains.	Grains.	Inch.	
Trial gun No. 1 -----	500	60	557	.6	7½
Trial gun No. 2 -----	500	50	390	.54	5
Altered musket-----	500	70	658	.685	6½
Trial carbine-----	500	50	390	.54	4½
Trial gun No. 1 -----	1,000	60	557	.6	None made
Trial gun No. 2 -----	1,000	50	390	.54	3
Altered musket-----	1,000	70	658	.685	4
Trial carbine -----	1,000	50	390	.54	2½

LENGTH OF PISTOL BARREL.

The following experiments were made subsequently to the action of the Ordnance board, which had established a uniform calibre of .58 inch for all small arms.

Table of mean deviations for the 10 and 12 inch pistol barrels fired from a shoulder and rest.

Calibre, .58 inch; ball, 430 grs.; powder, 30 grs.; target, 12 by 12 feet.

Barrels—length.	Distance.	Mean deviations.		No. of shots.	No. of shots missed.	Remarks.
		Vertical.	Horizontal.			
Inches.	Yards.	Inches.	Inches.			
12	100	3.8	3.9	40	These trials were made to determine the comparative merits of two pistol barrels, one 10 and the other 12 inches in length.
10	100	4.1	3.6	40	
12	200	7.3	6.8	40	
10	200	15.8	7.1	40	
12	300	15.9	14.	40	2	
10	300	28.2	14.4	40	9	
12	400	32.4	16.8	20	5	
10	400	36.	19.8	20	10	

Table of penetrations in a target made of seasoned white pine plank one inch thick, and placed one and a half inches apart.

Distance.	10-inch.	12-inch.
100	3½	4½
200	3	4
300	2	2½
400	----	----

CONCLUSIONS.

CALIBRES.

An inspection of the foregoing tables will show, that the results obtained with the new trial arms (calibres .54 and .6 inch) are superior to those obtained with the altered percussion musket, (calibre .69 inch.)

This difference is undoubtedly due to the fact, that the last named arm is too light, and its bore too large, to admit of the use of a properly proportioned ball and charge of powder, without too much recoil, and spring of the barrel. Trial gun No. 1, with a calibre of .6 inch, having a thicker and heavier barrel, gave, in the main, better results than trial gun No. 2, with a calibre of .54 inch. It is not thought, however, that this increased accuracy is sufficient to compensate for the increased weight, as this arm weighs nearly one pound and a half more than the present percussion musket.

It is shown that the principles of the rifle and expanding ball can be applied to the common cavalry pistol, whose barrel is only 8 inches in length, so as to increase its efficiency from 100 to 500 yards: thus making it a serviceable arm for mounted troops and foot artillery.

To obviate the too great recoil, which might arise from

the use of the elongated ball in so light an arm, the calibre should be kept as small as possible.

All the facts, therefore, adduced from these experiments, show, that while a very efficient and serviceable rifled-musket can be made by the alteration of those now on hand in our arsenals, a weapon, lighter in weight of piece and ammunition—one possessing less recoil, and greater penetration and accuracy—can be had by reducing the calibre to either .54 or .6 of an inch. A size between these two, it is thought, would be most suitable for a uniform calibre.

LENGTH OF BARREL.

By comparing the tables of elevation, penetration, and mean deviation for the new rifle-musket, and the altered Harper's Ferry rifle, it will be seen that while the former gun communicates a greater velocity to the projectile, the latter sends it to its destination with the greater accuracy—the calibre, grooves, ball, and charge of powder, being the same in both instances.

The length of the new rifle-musket barrel is 40 inches, and its weight is 4.28 lbs.; the length of the altered rifle barrel is 33 inches, and its weight 5.17 lbs.; it follows, therefore, that while the greater force of the former is due to its superior length, the greater accuracy of the other is due to its superior weight, or thickness of metal. This difference of accuracy is too slight to be of much practical importance, and would hardly compensate for the increased weight of the barrel. A greater difference as regards force will be found between the results with the trial carbines and trial gun No. 2 of the same calibre.

Pistol barrels 8, 10 and 12 inches in length were tried. The mean of a large number of shots fired from each, shows, that the accuracy, as well as the force, increases with the

length of the barrel. As the 12-inch barrel was not found inconvenient to handle, when mounted as a pistol, this length is recommended for the service, in view of its superior efficiency in all other respects.

GROOVES.

Of the twenty-three varieties of grooves tried, in all, that of gun No. 16 was found to give uniformly the best results with the altered muskets, while it was found to be fully equal to any, for the new trial arms with smaller calibres. These grooves were the broadest and shallowest of any submitted to experiment. The general tendency of the results seems to confirm this conclusion, as it was found, in almost every instance, that the broader and shallower grooves gave the better practice, other things being equal.

Such grooves have the additional advantage of being easier to keep clean, and cheaper to make; at the same time, they expose fewer corners of lands to the marring influence of the head of the ramrod. Gun No. 16 was on one occasion fired two hundred times, without cleaning the bore or vent. Notwithstanding a thick accumulation of dirt at the bottom of the bore, the gun did not fail once to explode; and but little difficulty was found in ramming the ball to its place. The same gun was fired upwards of a thousand times in all, without producing any perceptible injurious effect on the lands.

The effect of breadth on grooves may be seen by comparing the practice made with guns 15 and 16. The grooves of these guns were alike in every particular, except in width—those of No. 15 being about .15 inch narrower than No. 16.

The effect of depth is best shown by comparing the results obtained with guns 7 and 12—the former having

grooves .0075 inch in depth, and the latter .015 inch; in all other respects these grooves were alike.

The superiority of the decreasing over the uniform depth for grooves is confirmed. It was generally found that a slope of groove commencing at the muzzle with a depth of .005 inch, and ending at the breech with .015 inch, gave less deviation, and less "drop" of the ball, than a slope commencing at the muzzle with a depth of .005 inch, and ending at the breech with .02.

The "rounded" grooves seemed to take a firmer hold on the ball, with the same depth of cut, than the circular ones, and, for this reason, generally gave better practice. The difference in the modes of constructing these grooves is shown by a sketch appended to the descriptive list of the barrels.

The effect of increasing the twist is to increase the *drift*, and reduce the deviations. This supposes, of course, that the twist is not increased so much as to prevent the ball from following the grooves, as was the case in guns 18 and 19, after their bores became foul. Owing to the reduced velocity of the pistol ball a greater twist was found to answer better for this arm than the ordinary one of six feet.

It is therefore recommended, that the grooves of all small arms be *three* in number, *equal* to the lands in width, and *rounded* in shape; that the twist be a uniform spiral, one turn in six feet for the long, or musket barrels, and one turn in four feet for the short, or pistol barrels; and that the depths of all the grooves be cut uniformly decreasing, commencing in the musket at the breech with .015 inch, and ending at the muzzle with .005 inch; and in the pistol, at the breech with .008 inch, and ending at the muzzle with .005 inch; or, in other words, that the *slope* of the grooves of all small arms shall be the same, commencing at the muzzle with .005 inch in depth.

PROJECTILES.

The only modification of the exterior of the ball consisted in lengthening the cylindrical portion, for the purpose of giving it four instead of three grooves ; the results of the practice, however, were not as satisfactory as in the first instance, and no change is proposed for this part of the ball.

By reducing the size of the cavity and making it a perfect cone in shape, the tendency to rupture, or burst, by the force of the discharge was entirely obviated; the centre of gravity was thrown forward; the weight of the ball was increased without increasing its exterior size, and, as a consequence, the accuracy of its flight was considerably improved. By this change, the ball is also made stronger and stiffer, thereby rendering it better able to resist the effects of rough handling and transportation.

Owing to the reduced charge of powder and length of barrel of the pistol, the small cavity does not seem to answer well for this arm. That expansion does not take place sufficiently to enable the ball to hold firmly to the grooves of the barrel, is shown by the fact, that about 25 per cent. failed to go point foremost, while those with larger cavities, and thinner sides, seldom failed to fly accurately. This fact will make it necessary to have two different balls—one for the musket, and another for the pistol, differing in the size of their cavities.

The exteriors, however, being the same, each ball may be used in both arms should an emergency require it. The difference in the charges of powder for these two arms, will render separate cartridges necessary; it is thought, therefore, that no serious inconvenience will arise from having two distinct balls, and that the advantage gained, in point of accuracy, will justify it.

When paper is used as a wrapper or patch to the ball, fragments of it are nipped in the grooves at the moment of expansion and are found adhering to it after its flight. As might be supposed, this impairs the accuracy of its flight to a certain extent. When used as a wad between the powder and ball, it is not so objectionable. If paper be not used, the windage should be reduced as low as possible; *.0025 inch* for the smaller calibres, and *.005 inch* for the larger, or musket calibre, were found to be amply sufficient for all practical purposes, provided, that cast balls be properly swaged. Balls with *.01 inch* windage, used without paper, would not keep their places in the bore of the gun under all the circumstances of the service, even if the barrels were all made of the true calibre.

Drawings are appended, showing the weight, shape, and dimensions of the different balls used in the trials.

With the new musket and altered rifle, a charge of 60 grains of musket powder was found to answer better than one of 70 for the distances of 200 and 700 yards, the only distances at which comparisons were made.

With this charge of powder, and a ball weighing 500 grains, these guns have but little recoil. The altered musket, with a charge of 70 grains of powder and a ball weighing 730 grains, gives more recoil than the arms with the smaller calibres, yet experience shows that it is not inconveniently great, if the soldier be careful to hold the butt of his piece firmly against his shoulder.

Musket powder is recommended for all small arms. Du-pont's canister powder, of very fine grain, was tried in the pistol, but not with the same success as with the musket powder; the force of the ball was increased, but its accuracy was much diminished. The musket powder used in the trials was generally of a low proof range, varying from 60 to 280 yards range with the mortar eprouvette.

It is essential, not only to the snug fit of the ball, but to the accuracy of fire of the arm, that the bore should be as near the true calibre, as possible; it is, therefore, recommended that a reduction be made in the regulation limit allowed for the variation in the size of the bore. The present variation is .01 inch above the true calibre, but it is thought that this may be safely reduced to .0025 inch, or one-fourth of this amount.

Great credit is due to the mechanics of the Springfield Armory for the excellent workmanship exhibited in the different trial and model arms; to Mr. Allin, the master armorer, and to Mr. Buckland, the master machinist, for their valuable aid in carrying out the details of the various parts of the model arms; and to all persons connected with the armory for the zeal and interest manifested in the progress and results of the experiments.

The preparation of the model rifle was entrusted to the workmen of the Harper's Ferry Armory, but being dependent on the lock of the new rifle-musket, which was not finished at Springfield until quite late in the winter, the completion of this model has been somewhat delayed; the progress, however, which has been made on it, reflects equal credit on the mechanics of this establishment.

J. G. BENTON,
First Lieut. Ordnance.



PART IV.

EXPERIMENTS WITH NEW RIFLED ARMS,

&c., &c., &c.,

MADE AT

THE SPRINGFIELD ARMORY.

DECEMBER, 1855.

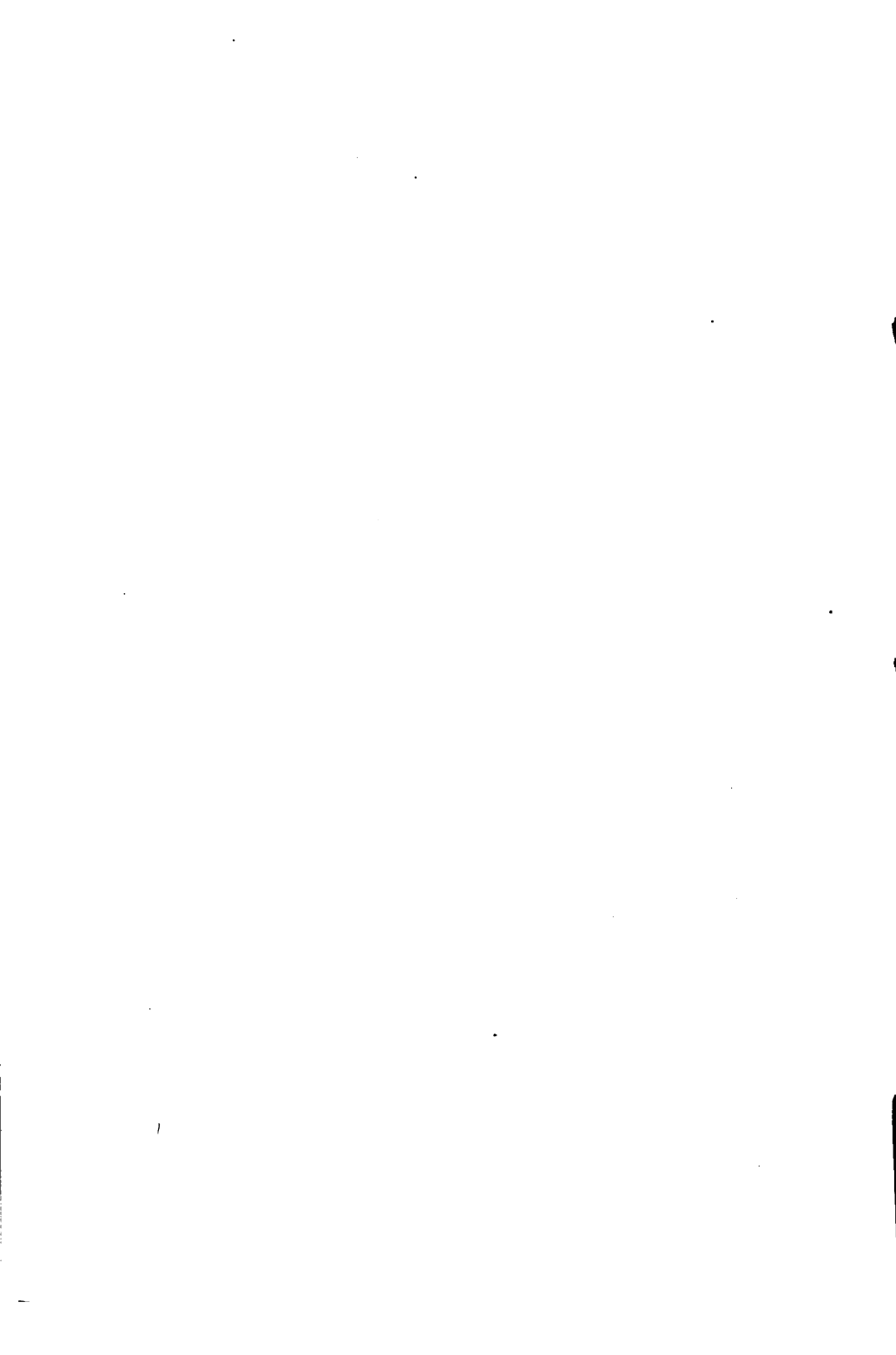

SUMMARY STATEMENT

OF THE

ACTION OF THE ORDNANCE BOARD IN RELATION TO NEW
MODELS FOR SMALL ARMS, &c.

ORDNANCE OFFICE,
Washington, June 26, 1855.

SIR: I have the honor to submit the report of the proceedings and recommendations of the Ordnance Board, in regard to the establishment of new models for the small arms for our military service. For reasons assigned by the board, which I think conclusive, a smaller calibre than that of our present musket, but greater than that of our rifle, viz: .58 inch, is proposed for all our small arms; 40 inches is recommended as the length of the musket barrel; 26 inches as that of the sapper's musketoön, which will be provided with a sword bayonet, and 10 inches for the barrel of the pistol, which barrel, being also provided with a suitable stock, will answer for a dragoon or artillery carbine, for which a range of 500 yards fits it. One lock, with magazine for 50 Maynard primers, will answer for either musket or musketoön, a smaller lock, with magazine for 25 primers, will serve for either the pistol or artillery carbine. All the barrels of .58 inch calibre to be rifled with three grooves, decreasing depth; the musket and musketoön to have a six-foot twist, and the carbine and pistol barrel a twist of four feet; in other words, the grooves to make a revolution in a length of six feet for the two first, and in a length of four feet for the last. It is recommended by the board, that our present rifles be enlarged in calibre to .58 inch, but no proposition has been made for a new model of this particular

arm, in the belief, it is supposed, that the sapper's musketoon may be substituted for it. Concurring as I do with the board in its other recommendations with regard to a new model, and the details which I submit for your sanction, I cannot agree with it in opinion as to the propriety of ceasing the fabrication of the arm now called the rifle. To arrange a new model of this arm in accordance with the main features of the other arms, it will only be necessary to enlarge the calibre from .54 to .58, and arrange the stock for the Maynard musket lock, the other points remaining nearly as at present. For such an arm we have a factory and extensive machinery capable of turning out at least 3,000 per annum. I cannot, therefore, recommend the omission of this arm in our future fabrication.

* * * * *

Very respectfully, your obedient servant,

H. K. CRAIG,

Colonel of Ordnance.

Hon. JEFFERSON DAVIS,

Secretary of War.

JULY 5, 1855.

The calibre of .58 of an inch for all small arms, the length of 40 inches for the musket barrel, and of 10 inches for the pistol barrel, with the details of the lock and other component parts, are approved as recommended * * *.

The present rifle, modified by the adoption of the new calibre and primer lock, will be continued, and will be issued to the sappers instead of the musketoon, the manufacture of which will be discontinued.

The pistol will be provided with a movable stock, by the application of which, it may be used as a carbine by light artillery and mounted troops.

JEFF'N DAVIS,

Secretary of War.

SMALL ARMS.

(ESTABLISHED IN 1855.)

Calibres.

- .69 inch—rifle-musket, model 1822, (altered.)
- .69 inch—rifle-musket, model 1842, (altered.)
- .58 inch—rifle-musket, model 1855, (new.)
- .58 inch—rifle, model 1841, (altered.)
- .58 inch—rifle, model 1855, (new.)
- .58 inch—pistol-carbine, model 1855, (new.)

NOMENCLATURE.

RIFLE-MUSKET, (1855.)

Barrel: Muzzle—*bayonet stud and front sight*, breech, flats, bevels and oval, cone seat, vent, vent screw, cone screw thread, vent screw thread, rear sight mortice, rear sight screw hole, bore, grooves, lands. The exterior shape of this barrel tapers with a gentle re-entering curve from the breech to the muzzle. That portion of the flat in rear of the cone seat is parallel to the axis of the bore.

Breech screw: Plug with threads (16 to the inch,) tenon, shoulders, tang, tang screw hole, bevel.

Rear sight: *Base*—fence, offsets, ears, slot and groove for spring, screw hole, tenon, groove for barrel: *Spring*—blade, screw hole: *Leaf*—frame, slot, tongue, rivet, rivet hole, sight notches, graduation marks: *Slide*—back piece, grooves, rivet holes, handles, spring, sight notch, rivets.

Tang screw: Shoulder.

Cone: Screw thread, shoulder, square, nipple, vent.

Bayonet: *Blade*—point, face flute, back flutes, edges of back and blade, bevels, elbow, neck: *Socket*—muzzle end, bridge end, bridge, mortice, shoulder for clasp, stop pin: *Clasp*—body, studs, bridge, groove, stop, clasp screw.

Lock—(Maynard primer:) *Lock plate*—front and rear ends, sides, cone seat notch, bolster, main spring notch, chamfer, bevel, magazine, (mouth, throat and body,) 5 holes for the pivots of the main spring and bridle of the tumbler, cover catch, and cover hinge stud, 7 screw holes, 3 mortices for sear spring stud and cover hinge, 1 slot for feeding finger: *Hammer*—body, crook, head, comb, checking, countersink, cutter, slit, tumbler hole: *Tumbler*—body, friction shoulder, arbor, square, pivot, swivel arm, swivel slot and pin holes, half cock notch, cock notch, screw hole: *Bridle*—body, eye, pivot, 3 holes for tumbler pivot, sear screw, and bridle screw: *Bridle screw*: *Sear*: body, eye, nose, tang, screw hole. *Sear screw*: *Sear spring*: blade, (upper and lower branch and elbow,) eye, stud screw hole: *Sear spring screw*: *Main spring*: blade, (upper and lower branch and elbow,) hook, pivot, tang: *Swivel*—body, axis, 2 holes for tumbler pin and finger pivot. *Tumbler and swivel pin*: *Feeding finger*: eye pivot, crook, curve, point: *Finger spring*—eye, long and short branch, elbow.

Magazine cover: Body, hinge, jaws, rivet, rivet holes, chamfer, thumb nail notch and catch notch. *Stud*—head rivet hole, stem, and countersink rivet, (hexagonal in shape.) *Cover catch*—head, notch, foot, screw hole. *Cover catch screw*.

Two side screws.

In all the screws the parts are—the stem, the head, the slit, and the thread.

The bottom of the slit of the larger screws is concave; the base screw of the rear sight has two holes in the head instead of a slot, in order that it may not be removed by the ordinary screw driver.

Mountings: *Upper and lower bands*—body, creases, letter U, to designate the upper from the lower edge. *Middle*

band—body, creases, letter U, stud, hole for swivel rivet. *Middle band swivel*—wire, eyes, rivet. *Band springs*—stem, wire, shoulder. *Side screw washers*—countersink, hole for screw. *Guard*: *guard plate*—body, bolsters, trigger stud, 2 holes for guard bow, 2 for wood screws, and 1 for trigger screw: *Guard bow*—body, pillars, stems with their screw threads, swivel stud, piece and hole, 2 *nuts* for stems, swivel, and rivet: *Trigger*—blade, tang or finger piece, hole for screw: *Trigger screw*—two wood screws for guard plate. *Butt plate*—body, toe, heel, hollow, corners, tang and screw holes. Two wood screws for butt plate.

Ramrod: Stem, swell, head, cup, screw. *Stop* for rod.

Stock: *Butt*—comb, handle, head, facings, first and second reinforce, chase, shoulders for bands and tip; *grooves* for barrel and ramrod; *beds* for tang and tenon, lock, washers, guard plate, nuts for guard bow and trigger stud, butt plate, and band springs and tip; *mortices* for the trigger, and stop; *rod holes* for the rod, the side screws, tang screws, guard screws, butt plate screws, band springs and tip rivet.

Tip: Recess for stock, groove for rod, rivet hole, and shoulder.

Materials of which the parts are made.

Steel.—Tumbler, lock swivel, feeding finger, finger spring, cover catch, sear, sear spring, main spring, band springs, ramrod, blade of bayonet, all of the rear sight with the exception of the screw, screw driver, wiper, and ball screw, cone.

Brass.—Tip.

Wood.—Stock (black walnut.)

Iron.—Socket of bayonet, and all other parts not enumerated under the three preceding heads.

RIFLE-MUSKET, (1842.)

This arm differs from the original model in the following particulars: 1st. The bore is grooved. 2d. It has a *rear sight* similar to that for the new musket, and a *front sight* of iron attached to the upper strap of the upper band. To prevent the band from moving sideways, a short stud is attached to the under side of the strap, which fits into a groove in the barrel. 3d. The head of the ramrod is reamed out to fit the pointed end of the ball. 4th. The lock is altered to the Maynard principle, differing from the one described for the new rifle-musket of 1855, by its size, the absence of the swivel, and the facts, that the main spring is fastened by a screw, and the finger spring by a pin. 5th. To adapt the cone seat to this modified lock, a portion of the breech of the barrel is cut off, and a new breech piece with cone seat attached, is screwed on in its place. *Breech piece*: body, shoulder, screw thread, chamber, (conical,) tang, tenon, tang screw hole, chamfer, notch for side screw, cone seat, vent, vent screw, vent screw thread, cone thread.

RIFLE-MUSKET, (1822.)

The bayonet of this arm has no clasp, or ramrod spring; in all other respects the nomenclature is the same as that of the rifle-musket, (1842.)

PERCUSSION-RIFLE, (1841.)

The bore of this arm is reamed up and re-rifled; it also has a rear sight similar to the rifle-musket of 1855, and a stud and guide attached for a sword bayonet.

RIFLE, (1855.)

The exterior size of the barrel is nearly the same as that of the model of 1841. The barrel has a stud and guide for attaching a sword bayonet. The breech and cone seat are finished like the same parts of the new rifle-musket.

Lock: Identical with that of the new rifle-musket.

Rear sight: Similar to that of the new rifle-musket.

Mountings: Similar to those of the new rifle-musket, with the addition of a catch box, smaller than the one on the rifle of 1841.

Ramrod: Similar to the new rifle-musket.

Sword bayonet: *Blade*—shoulder, back, edge, bevel, point, curvature, groove, *tang* riveting, rivet hole, rivet.

Hilt: *Gripe*—ridges, back, beak, slot for stud, slot for guide, hole for finger piece, hole for spring screw, hole for rivet (*tang*,) mortice for *tang*: *Finger piece*—head, notch.

Finger piece spring—blade, screw hole, boss: *Guard*—long and short branch, knobs, muzzle socket.

Scabbard: Black leather, with brass band and tip.

Materials.

Steel.—Tumbler, lock swivel, feeding finger, cover catch, sear, all the springs, ramrod, blade of sword bayonet, finger piece, rear sight, except screw, cone, screw driver, ball screw and wiper.

Brass.—Sword bayonet handle, front sight, and all the mountings.

Wood.—Stock, (black walnut.)

Iron.—All the remaining parts.

PISTOL-CARBINE, (1855.)

Barrel: Muzzle, front sight, breech, breech pin threads, flats, bevels and oval, cone seat, vent, vent screw, bore, grooves, lands. This barrel tapers with a straight line from breech to muzzle. The portion of the flat in rear of the cone seat is parallel to the axis of the bore.

Breech screw: Plug, with threads (16 to the inch,) tenon, shoulders, tang, tang screw hole, bevel sight mortice.

Cone: Same as for musket.

Rear sight: Base, ears, joint screw, screw hole, 1st, 2d, and 3d leaves, 4 sight notches, eye joint, screw holes.

Tang screw: Shoulder.

Lock: Same as for rifle-musket, 1855, except in size, which is reduced to conform to a magazine capable of holding one half a strip of primers.

Mountings: *Band, swivel, and spring*, correspond to the middle band, swivel, and spring of the new musket.

Guard plate: *Butt cup*—screw hole, tang. *Butt strap*—holes for catch spring and hook, tang, strap, and guard plate screws, shoulders for breech screw tang, and butt cup tang, reinforces for hook, and catch spring. *Cup screw*—head, eye. *Swivel ring*. The remaining mountings are similar to the corresponding parts of the new rifle-musket.

Ramrod: Head (riveted on), cup, foot with a female screw.

Ramrod swivel: Two side bars, screw, cross bar, riveted into the side bars.

Stock: Butt, handle, curve, facings, reinforce, chase; *shoulders* for band and tip, *grooves* for barrel and ramrod; *beds* for tang and tenon, lock, washers, guard plate, nuts for guard bow and trigger stud, butt plate, band spring, tip, butt cup and strap, butt piece cap, and catch spring, hook nut; *mortices* for trigger, hook, and catch spring; *holes* for rod, tip rivet, band spring, side screws, tang screw, cup screw, strap screw, butt plate screws, and cap screws.

Butt piece: *Plate*—2 wood screws; *cap*, hollow, upper and lower tang, screw holes, two wood screws, cavity for pistol handle, hook, stem, nut; *spring catch*, screw, head, blade; *finger piece*, loop for spring, screw thread, rivet and nut.

Materials.

Steel.—Cone, tumbler, lock swivel, finger, sear, lock springs, band springs, ramrod, except the head, rear sight

except screw, spring catch, screw driver, wiper and ball screw.

Brass.—Butt plate, butt cup, cup, guard plate and bow, band, and tip.

Wood.—Stock and butt piece.

Iron.—Head of ramrod, and remaining parts.

PRINCIPAL DIMENSIONS, WEIGHTS, ETC., OF SMALL ARMS.

Dimensions.	Rifle muskets.			Rifles.		Pistol carbine.
	1832.	1840.	1855.	1841.	1855.	1855.
	Inches.	Inches.	Inches.	Inches.	Inches.	Inches.
<i>Barrel.</i> {	Diameter of bore	0.69	0.69	0.58	0.58	0.58
	Variation allowed, more.....	0.015	0.015	0.0025	0.0025	0.0025
	Diameter at muzzle.....	0.82	0.85	0.78	0.90	0.90
	Diam'r at breech between flats.	1.25	1.25	1.14	1.15	1.14
	Length without breech screw.	42.	42.	40.	33.	33.
<i>Bayonet.</i> —Length of blade.....	18.	18.	18.	21.7	21.7
<i>Ramrod.</i> —Length.....	41.96	41.70	39.60	33.00	33.00	12.
<i>Arm complete.</i> {	Length without bayonet.....	57.64	57.80	55.85	48.8	49.3
	With bayonet fixed.....	73.64	75.80	73.85	71.3	71.8
	With butt-piece.....
<i>Grooves</i> {	Number.....	3	3	3	3	3
	Twist	6.	6.	6.	6.	6.
	Width	0.36	0.36	0.30	0.30	0.30
	Depth at muzzle.....	.005	.005	.005	.005	.005
	Depth at breech.....	.015	.015	.015	.013	.013
WEIGHTS.						
<i>Barrel,</i> without breech screw.....	Lbs.	Lbs.	Lbs.	Lbs.	Lbs.	Lbs.
<i>Lock,</i> with side screws.....	4.	4.19	4.28	4.8	4.8	1.4
<i>Lock,</i> with side screws.....	* .95	.95	.81	.55	.81	.6
<i>Bayonet</i>	0.73	0.64	.72	3.05	3.05
<i>Arm complete.</i> {	Without bayonet.....	9.06	9.51	9.18	9.68	9.93
	With bayonet.....	9.82	10.15	9.90	12.72	12.98
	With butt-piece.....
						5.09

* Maynard primer.

Table of mean deviations for the new Rifle-Musket fired from a fixed rest.

Weight of ball, 500 grains; weight of powder, 60 grains.

Distance.	No. of shots.	Mean deviations.		Aggregate mean deviations.		
		Vertical.	Horizontal.	Shots.	Vertical.	Horizontal.
Yards.		Inches.	Inches.		Inches.	Inches.
200	25	4.9	3.6	50	4.4	3.4
200	25	3.9	3.3			
300	25	8.4	8.6	50	9.	7.3
300	25	9.7	6.			
400	25	10.4	9.6	50	11.2	9.4
400	25	12.	9.2			
500	25	19.2	16.8	50	17.4	14.4
500	25	15.6	12.			
600	25	25.2	14.4	50	24.6	13.8
600	25	24.	13.2			
700	25	30.	20.6	50	28.8	19.9
700	25	27.6	19.2			
800	25	34.9	19.2	53	37.1	18.9
800	28	39.4	18.5			
900	40	58.8	27.6	84	52.8	24.8
900	24	50.4	21.6			
900	20	49.2	25.2			
1000	27	60.	25.2	120	55.9	25.5
1000	20	70.8	19.2			
1000	25	48.	29.8			
1000	23	61.2	26.4			
1000	25	39.6	21.6			

Table of mean deviations for the Altered Rifle fired from a fixed rest.

Weight of ball, 500 grains; weight of powder, 60 grains.

Distance.	No. of shots.	Mean deviations.		Aggregate mean deviations.		
		Vertical	Horizontal.	Shots.	Vertical.	Horizontal.
Yards.		Inches.	Inches.		Inches.	Inches.
200	25	4.3	3.7	50	3.9	3.7
200	25	3.6	3.8			
300	25	7.3	6.	50	7.9	7.
300	25	8.6	8.1			
400	25	10.5	9.9	50	11.8	11.
400	25	13.2	12.			
500	25	13.2	15.6	50	15.	12.7
500	25	16.8	9.8			
600	26	22.8	13.2	50	18.6	14.4
600	24	14.4	15.6			
700	24	22.8	19.2	48	25.2	16.2
700	24	27.6	13.2			
800	21	39.6	20.4	49	37.8	17.4
800	28	36.	14.4			
900	32	55.2	20.4	86	52.4	20.
900	23	43.2	19.2			
900	31	58.8	20.4			
1000	28	66.	21.6	120	58.	25.2
1000	32	52.8	34.8			
1000	24	61.	25.2			
1000	21	64.8	14.4			
1000	25	45.6	30.			

Table of mean deviations for the Altered Musket fired from a fixed rest.

Weight of ball, 730 grains; weight of powder, 70 grains.

Distance.	No. of shots.	Mean deviations.		Aggregate mean deviations.		
		Vertical.	Horizontal.	Shots.	Vertical.	Horizontal.
Yards.		Inches.	Inches.		Inches.	Inches.
200	25	5.7	6.9	50	5.7	5.2
200	25	5.7	3.6			
300	25	3.7	4.8	50	4.9	4.6
300	25	6.2	4.5			
400	25	18.	14.4	50	15.6	12.7
400	25	13.2	11.			
500	25	16.8	10.5	50	15.6	11.9
500	25	14.4	13.2			
600	25	24.	18.	50	24.6	16.
600	25	25.2	14.			
700	25	27.6	19.2	50	28.8	15.6
700	25	30.	12.			
800	25	34.9	19.2	50	35.4	27.5
800	25	36.	34.8			
900	25	51.6	28.8	50	55.2	29.4
900	25	58.8	30.			
1000	25	42.	34.8	50	61.2	26.4
1000	25	80.4	18.			

Table of mean deviations for the Pistol-Carbine fired from shoulder and rest.

Weight of ball, 450 grains; weight of powder, 40 grains.

Distance.	No. of shots.	Mean deviations.		Aggregate mean deviations.		
		Vertical.	Horizontal.	Shots.	Vertical.	Horizontal.
Yards.		Inches.	Inches.		Inches.	Inches.
100	25	4.	3.1	50	3.6	3.2
100	25	3.3	3.3			
200	25	6.8	5.7	50	7.6	6.4
200	25	8.4	7.2			
300	25	13.4	9.4	50	19.9	10.7
300	25	26.4	12.			
400	25	36.	15.6	50	30.	13.2
400	25	24.	10.8			
500	25	29.2	18.	50	32.6	18.6
500	25	36.	19.2			

At a distance of 600 yards 23 out of 52 shots struck the target, which was 16 feet high and 24 feet long.

ANGLES OF ELEVATION.

Table of angles of elevation for new rifled arms, obtained by means of the firing machine.

Distance.	New Rifle musket.	Altered Rifle.	Altered Musket.	Remarks.
	Weight of ball, 500 grains. Weight of powder, 60 grains.	Weight of ball, 500 grains. Weight of powder, 60 grains.	Weight of ball, 730 grains. Weight of powder, 70 grains.	
Yards.	° /	° /	° /	Each angle is the mean of 50 shots.
200	0 20	0 25	0 30	
300	0 40	0 50	1 00	
400	1 05	1 10	1 30	
500	1 30	1 45	1 50	
600	2 00	2 10	2 15	
700	2 20	2 35	2 50	
800	2 50	3 00	3 15	
900	3 30	3 40	4 10	
1000	4 15	4 30	4 50	

HEIGHTS OF HAUSSE, ETC.

Table of approximate heights for rear sights of new arms, measured from the line of metal of the barrel. Pieces fired from the shoulder and rest.

Distance.	New Rifle-musket.	Rifle-musket (altered.)	Remarks.
	Weight of ball, 500 grs. Weight of powder, 60 grs.	Weight of ball, 730 grs. Weight of powder, 70 grs.	
Yards.	Inches.	Inches.	
100	.40	.42	The top of the front sight is seen "fine" through the notch of the rear sight.
200	.54	.62	
300	.70	.82	
400	.88	1.08	
500	1.10	1.34	
600	1.35	1.65	
700	1.63	1.96	
800	1.94	2.28	
900	2.28	2.61	
1000	2.63	2.94	

Position of front and rear sights.

	Rifle musket, (new.)	Rifle, (new and altered.)	Rifle musket, (altered.)	Pistol carbine, (new.)
	Inches.	Inches.	Inches.	Inches.
Distance between sights - - - - -	32.5	29.	33.9	12.35
Height of front sights - - - - -	.25	.30	.30	.20
Diameter of barrel at rear sight - -	1.025	1.10	1.11	*.88
Diameter of barrel at front sight - -	.787	.90	.87	.82

* This sight is affixed to the tang.

Table of mean deviations for new rifle-musket fired from a shoulder and rest.

Target, 16 by 24 feet.

Distance.	No. of shots.	Mean deviations.		Aggregate mean deviations.			No. missed.	Date.
		Vertical.	Horizon- tal.	Shots.	Vertical.	Horizon- tal.		
Yards.		Inches.	Inches.		Inches.	Inches.		
100	10	1.8	1.1	20	1.9	1.5	Oct. 5
100	10	2.1	2.					Oct. 6
200	10	5.2	4.4	40	4.4	3.8	Oct. 5
200	10	3.9	4.3					Oct. 6
200	10	4.2	3.2					Oct. 8
200	10	4.3	2.7					Dec. 5
300	10	5.1	5.2	30	5.5	5.1	Oct. 6
300	10	4.3	6.8					Oct. 8
300	10	7.2	3.6					Dec. 5
400	10	11.2	6.4	40	9.1	8.8	Oct. 6
400	20	10.	10.6					Oct. 8
400	10	6.1	9.6	20	13.6	17.1	Dec. 6
500	10	8.	10.2					Dec. 5
500	10	19.2	24.	20	22.2	14.6	Dec. 17
600	10	20.4	8.4					Dec. 5
600	10	24.	10.8	20	30.6	14.4	Dec. 17
700	10	21.6	13.2					Dec. 15
700	10	39.6	15.6	20	39.6	21.	Dec. 17
800	10	46.8	26.4					Dec. 5
800	10	32.4	15.6	20	34.8	21.4	Dec. 17
900	10	19.2	14.					Dec. 5
900	10	50.4	28.8	20	34.8	21.4	Dec. 5
900	10	50.4	28.8					Dec. 17

These shots were fired at different times for the purpose of determining the graduations of the rear sight. The results are nearly equal to those obtained by firing the same gun from the fixed rest or machine.

PENETRATIONS.

Table of penetrations in a target made of seasoned white pine plank one inch thick, and placed one and a half inches apart.

Arm.	Weight of ball.	Weight of powder.	Diameter of ball.	Planks penetrated.	Distance.
	Grains.	Grains.	Inch.	Number.	Yards.
Altered rifle - - - -	500	60	.5775	9½	200
Altered musket - - - -	730	70	.685	10½	200
New rifle-musket - - - -	500	60	.5775	11	200
Pistol-carbine - - - -	450	40	.5775	5¾	200
Altered rifle - - - -	500	60	.5775	5¾	600
Altered musket - - - -	730	70	.685	6½	600
New rifle-musket - - - -	500	60	.5775	6½	600
Pistol-carbine - - - -	450	40	.5775	3	500
Altered musket - - - -	730	70	.685	3½	1000
Altered rifle - - - -	500	60	.5775	3	1000
New rifle-musket - - - -	500	60	.5775	3½	1000

At 1,000 yards a ball from the new rifle-musket passed completely through the frame of the target, which was made of solid white pine three inches thick.

POINTS OF TRAJECTORY OF NEW RIFLE-MUSKET.

Distance, 200 yards; weight of ball, 500 grains; weight of powder, 60 grains.

Height (inches) - - -	14.5	17.7	19.3	19.6	16.	10.
Distance (yards) - -	50	75	100	125	150	175

POINTS OF TRAJECTORY OF ALTERED MUSKET.

Distance, 200 yards; weight of ball, 730 grains; weight of powder, 70 grains.

Height (inches) - - -	16.2	18.8	19.7	20.9	17.5	10.4
Distance (yards) - -	50	75	100	125	150	175

POINTS OF TRAJECTORY OF HARPER'S FERRY RIFLE.

Distance, 500 yards; weight of ball, 400 grains; weight of powder, 50 grains.

Height (inches) - - -	85.	141.	145.	150.	97.	0.
Distance (yards) - -	100	200	250	300	400	500

The last trajectory was determined by Major Mordecai, Ordnance Department, at the Washington arsenal, in 1854.

The highest point of the 100 yards trajectory for the pistol-carbine, is 12 inches; and the highest point of the 300 yards trajectory for the rifle-musket, is 40 inches.

The elongated musket balls do not cease to ricochet on level ground, at the distance of 1,000 yards.

A strong wind blowing perpendicularly to the direction of the rifle-musket ball, will deflect it from its course 12 feet in 1,000 yards, about 3 feet in 500 yards, and about $\frac{1}{2}$ foot in 200 yards.

The effect of wind on the pistol-carbine balls is somewhat greater, for the same distance.

When two oblong balls are fired from the new rifle-musket, or altered rifle, with the ordinary service charge of 60 grains, they separate from each other and from the plane of fire about 4 feet in a distance of 200 yards. If the piece be held firmly against the shoulder, no serious inconvenience will be felt in firing this increased charge; the only precaution necessary to be observed in aiming, is to give the barrel greater elevation than for the single ball, in the proportion of 6 feet for 200 yards.

In cases of emergency, firing with two balls might be effectively employed against masses of infantry and cavalry, if the distance does not exceed 300 yards.

STRENGTH OF RIFLE BARRELS.

In order to test the strength of the different barrels of the service small arms, one of each was taken indiscriminately from a pile of finished arms, and fired with an increasing number of service charges, placed one above the other, with results as stated in the following table :

Kind of gun.	Number of increasing charges which passed out of the barrel.	Number of charges that remained in the barrel at the last fire.	Remarks.
Rifle-musket (new) -	4	5	All the balls were found in the barrel at 5th fire, the lower one partially melted. Two charges of powder were burned.
Harper's Ferry rifle (reamed up to .58 in.)	5	6	At the 6th fire all the balls remained in the barrel except the upper one, and that was thrown out of the barrel. Two charges of powder were burned.
Altered musket - - - (model of 1842.)	9	10	At the 10th fire all the balls remained in the barrel about half-way from the muzzle, except the upper one, and that was thrown out of the barrel. One charge of powder was burned.

At the last fire with each barrel, the entire force of the powder escaped through the vent with a prolonged sound resembling steam of high pressure. Although all the barrels were rifled, and were morticed and tapped for the sight base, they passed through the firings uninjured.

The rifle barrel was made of steel, the others of iron.

INITIAL VELOCITIES.

*Initial velocities of elongated expanding balls, as determined by the
Musket Ballistic Pendulum at the Washington Arsenal.*

No. of fire.	Kind of gun.	Weight of powder.		Weight of ball.	Point of impact.	Vibration of pendulum.		Velocity. Feet.	Date, &c.
		Gr.	Gr.	Inches.	°	'			
1	Altered Harper's Ferry rifle, 1856.	60	510	79.	5	42	826	} July 11, 1856.	
2	" "	60	510	78.75	6	10	896		
3	" "	60	510	78.5	6	26	937		
4	" "	60	510	78.75	6	14	905		
5	" "	60	510	79.	6	35	951		
6	" "	60	510	78.75	6	20	920		
7	" "	60	510	79.	6	26	932		
8	" "	60	510	78.87	6	24	929		
9	" "	60	510	79.	6	28	936		
Mean velocity, or feet per second --								914	
1	New rifle-musket, 1856.	60	510	80.	6	00	858	} July 24.	
2	" "	60	510	78.87	6	36	957		
3	" "	60	510	79.	6	42	970		
4	" "	60	510	79.12	6	42	967		
5	" "	60	510	79.	6	49	989		
6	" "	60	510	79.	6	49	989		
7	" "	60	510	79.	6	33	945		
8	" "	60	510	79.	6	42	970		
9	" "	60	510	79.	6	52	994		
10	" "	60	510	79.	6	50	989		
Mean velocity -----								963	

Initial velocities—Continued.

No. of fire.	Kind of gun.	Weight of powder.		Point of im- pact.	Vibration of pendulum.	Velocity.	Date, &c.
		Gr.	Gr.				
1	Altered rifle-musket, Harper's Ferry, 1856.	70	740	79.75	8 8	809	July 11.
2	" "	70	740	79.25	9 00	901	July 11.
3	" "	70	740	79.25	8 46	878	July 11.
6	" "	70	740	79.25	8 51	884	July 23; gun cool.
7	" "	70	740	79.5	8 28	850	Do. do.
8	" "	70	740	79.	8 43	873	July 23.
9	" "	70	740	79.	9 15	927	July 23.
10	" "	70	740	79.	9 24	943	July 23.
Mean velocity -----						863	
1	Altered rifle-musket, Springfield, 1856.	70	740	79.75	8 17	822	} July 11.
	" "	70	740	79.62	8 18	827	
3	" "	70	740	79.	8 41	870	
4	" "	70	740	79.62	8 58	900	
5	" "	70	740	79.	8 56	897	
6	" "	70	740	79.	9 10	920	
7	" "	70	740	79.	9 6	914	
Mean velocity -----						879	
8	Smooth-bored percus- sion musket.	70	740	79.62	9 33	949	} July 23; gun warm, had been fired seven times previous to the com- mencement of this series of fires.
9	" "	70	740	79.37	9 42	969	
10	" "	70	740	79.5	9 18	928	
11	" "	70	740	79.5	9 33	951	
12	" "	70	740	79.5	9 45	971	
Mean velocity -----						954	

Initial velocities—Continued.

No. of fire.	Kind of gun.	Weight of		Point of im- pact.	Vibration of pendulum.	Velocity.	Date, &c.	
		powder.	of ball.					
		Gr.	Gr.	Inches.	° /	Feet.		
1	Pistol-carbine, 1856.	40	468	79.37	3 23	533	} July 24	
2	" "	40	468	75.62	3 25	544		
3	" "	40	468	78.75	3 27	548		
4	" "	40	468	78.37	3 46	598		
5	" "	40	468	78.37	3 40	582		
6	" "	40	468	78.87	3 55	616		
7	" "	40	468	78.75	4 28	706		
8	" "	40	468	79.37	4 20	680		
9	" "	40	468	78.62	3 53	617		Ball struck wooden block sidewise, and fell to the ground.
10	" "	40	468	79.	3 51	610		July 24.
Mean velocity - - - - -						603	July 24.	

In these experiments for obtaining the initial velocities of the elongated expanding balls, used in rifled small arms, great care was observed to obtain uniform results by weighing each charge of powder and ball, and to make them correspond to the practice of the service, by not wiping out the bores until the firings had been completed.

By an inspection of the tables, it will be perceived that the first few shots of each series of fires were, in general, less than the succeeding ones. The exceptional cases are where the same gun had been fired several times before the record was commenced, as in the case of the smooth-bored musket. It is thought that this increase of velocity is due, for the most part, to the increase in the temperature of the

barrels, as they were discharged as fast as they could be loaded : to produce uniform results, therefore, in a series of fires, (so far as this source of error is concerned,) such intervals of time should be observed as will bring the barrel to a uniform degree of temperature.

The loss of velocity due to the rifling of the barrels of .69 inch calibre is about 30 feet ; and the loss of velocity due to reducing the length of a barrel, the calibre of which is .58 inch, from 40 to 33 inches, is about 50 feet.

The initial velocities of the round balls under the old system, obtained from the same pendulum, by the experiments of Maj. Mordecai, in 1844, are as follows, viz :

	Powder.
Musket.....1,500 feet.....	110 grains.
Rifle.....1,750 feet.....	70 “
Pistol..... 947 feet.....	35 “

RECOIL.

The following table is given to show the relative force of recoil of the different kinds of small arms now adopted into our service. The figures are obtained by multiplying the weight of the ball by its initial velocity, and dividing the product by the weight of the gun from which it was fired ; the result is the space over which the gun would pass in a second of time, were it free to move :

Altered Harper's Ferry rifle.....	6.88 feet.
New rifle-musket.....	7.08 “
Pistol-carbine	8.06 “
Altered rifle-musket.....	9.36 “
Percussion musket, round ball and 110 grains of powder.....	8.83 “

BALL FOR ALTERED MUSKET.

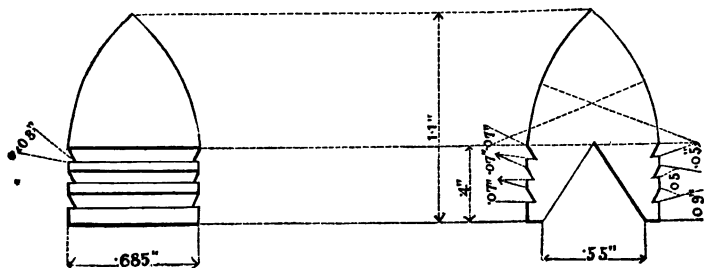

Weight of ball, 730 grains; weight of powder, 70 grains.

BALLS FOR NEW RIFLE-MUSKET AND PISTOL-CARBINE.

No. 1.

No. 2.

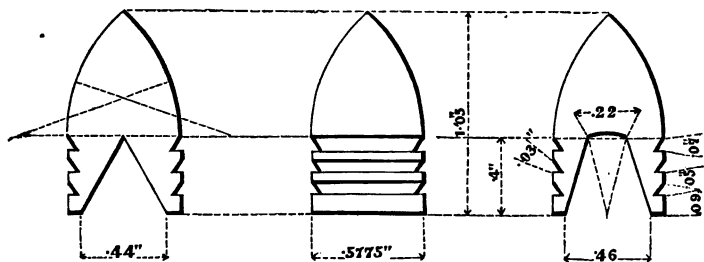

Weight of No. 1, 500 grains. Weight of No. 2, 450 grains.
 Weight of powder, 60 grains. Weight of powder, 40 grains.

No. 1, section of musket ball.

No. 2, section of pistol-carbine ball.

Both balls have the same exterior.

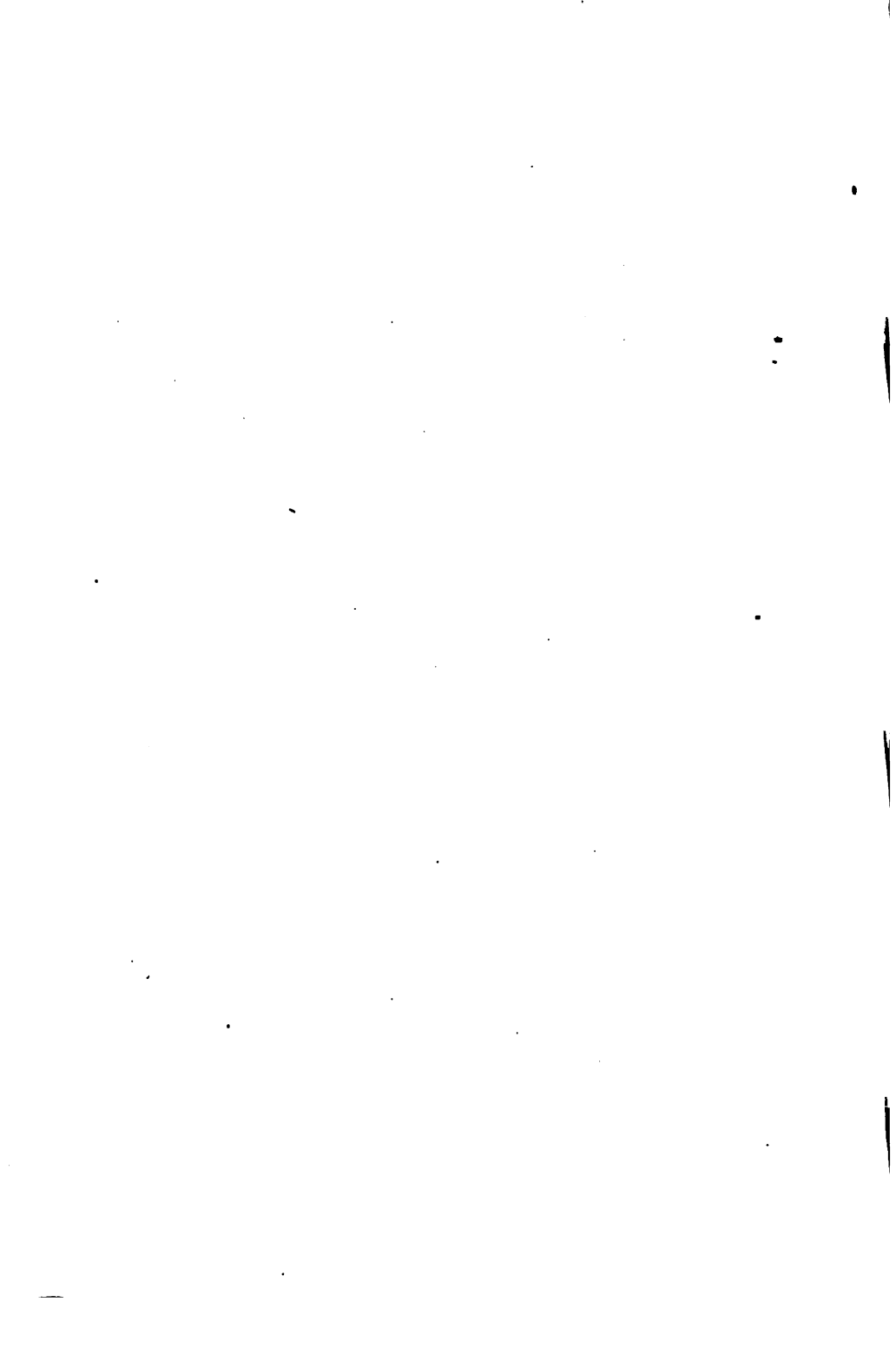

SUPPLEMENTARY TRIALS

WITH

THE NEW ARMS.

FIRE OF THREE BALLS.

The fire of two round balls in the smooth-bored musket has been considered to possess great advantages, when used against masses of troops at short distances; but its practical application has been very much restricted in warfare by the large size of the bores of military arms, requiring the use of a charge which was too severe in its effects on the soldier, and very injurious to the arms themselves. The reduced calibre of the new rifle-musket, and the increased weight of its barrel entirely remove these objections.

A few trials were lately made at the Washington Arsenal to test the effects of firing two and three round balls at a time from the new rifle-musket, and were attended with very satisfactory results; in fact, they demonstrated that the ordinary muzzle-loading musket possesses all desirable power of throwing round balls accurately and rapidly to a distance of 200 yards—beyond which the trials did not extend.

The round balls selected for trial were those used in the old rifle, having a diameter of .525 inch, and giving a windage of .027 inch when used in the new musket. It was found that this windage was sufficient to allow the balls to



drop readily and certainly into their places, when used without a paper wrapper; the loss of time, therefore, in drawing and returning the ramrod in loading was dispensed with. With the service charge of 60 grains of powder, the round balls were too much dispersed to be effective. With a charge of 100 grains and three balls, the dispersion was reduced within effective limits, with a moderate recoil of the piece.

In the preliminary trials, it was found that so far as the deviations of the balls from each other were concerned, there was but little difference between the fire of two and the fire of three balls, or, in other words, that the number of balls placed in a target whose height was that of a soldier in ranks, was in proportion to the number of balls used, or two to three.

The following are the results of firing at the distances of 100, 150, and 200 yards—five shots of three balls each being fired at each distance, from a shoulder and rest. At 100 yards, 15 balls were placed in the target, within a space of five feet square. At 150 yards, 14 balls were placed in the target in a space of five and a half feet high and six and a half feet long. At 200 yards, 13 balls were placed in the target in a space of six feet high and eleven feet long. For the 100 yards distance, the piece was aimed with the usual sight; for 150 yards, with the 200 yards sight; and for 200 yards, the 300 yards sight was used and the gun pointed three feet below the centre of the target. As the ricochet of the round ball on ordinary ground is very regular, many balls may be made to hit the object by aiming low, as was the case in the trials. In a trial to test the rapidity of loading, by dropping the balls into their places, it was found that the piece could be loaded and discharged five times in one minute. The piece was fired off-hand at a



target 100 yards distant; the whole of the fifteen balls were found in the target in a space five feet and a half high and seven feet long; the centre of the cluster being near the point aimed at.

No "leading" of the grooves was observed during the firings; the bore, however, became coated with the hard, dry residuum of the burnt powder, which it was necessary to remove, by softening with oil, or water, before the piece could be easily loaded again with the close fitting expanding ball.

CARTRIDGES.

CARTRIDGE FOR EXPANDING BALLS.

FULL SIZE FOR NEW MUSKET.

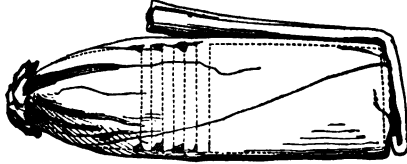

OUTER WRAPPER.

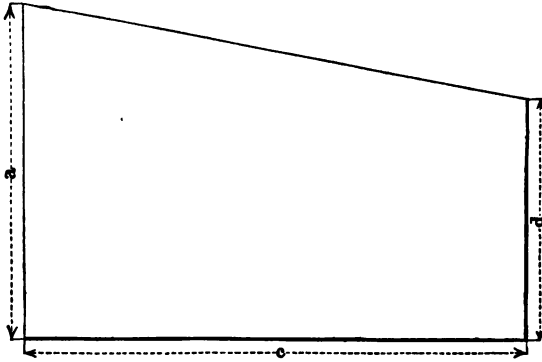

CYLINDER CASE

CYLINDER WRAPPER

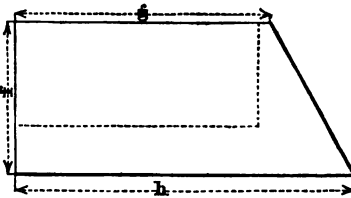
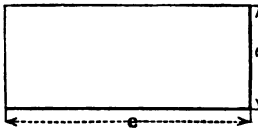

Table of dimensions for formers for making cartridges with elongated expanding balls. (The dimensions are referred to the plate by means of the letters placed opposite to them.)

	Altered musket.	New rifle musket.	Pistol carbine.	
	Inches,	Inches.	Inches.	
<i>a</i>	3.5	3.5	3.5	} Outer wrapper.
<i>d</i>	2.5	2.25	2.25	
<i>c</i>	5.25	4.25	4.25	
<i>a</i>	1.1	1.	.8	} Cylinder case.
<i>e</i>	2.75	2.	2.	
<i>f</i>	1.5	1.3	1.1	} Cylinder wrapper.
<i>g</i>	2.75	2.2	2.2	
<i>h</i>	3.75	3.	3.	

The diameters of the round sticks on which the powder cases are formed should be .69 inch for the old, and .58 inch for the new calibre. This will make the exterior diameter of the case somewhat larger than the ball, and will prevent the outer wrapper from binding around its base when the cartridge is broken.

The outer wrapper should not be made of too strong paper: that prescribed in the Ordnance Manual for blank cartridges, and designated as No. 3, will answer a better purpose for these cartridges than that designated as No. 1. The cylinder case should be made of stiff rocket paper, No. 4; and its wrapper may be made of paper No. 1, 2, or 3.

Before enveloping the balls in the cartridges, their cylindrical parts should be covered with a melted composition of one part beeswax and three parts tallow. It should be applied hot, in which case the superfluous part would run off; care, should be taken to remove all of the grease from the

bottom of the ball, lest by coming in contact with the bottom of the case, it penetrate the paper and injure the powder.

The balls being thus prepared, and the grease allowed to cool, the cartridges are made up as follows, viz: place the rectangular piece of rocket paper, called the cylinder case, on the trapezoidal piece, called the cylinder wrapper, as shown by the broken lines of the plate, and roll them tightly around the former stick, allowing a portion of the wrapper to project beyond both case and stick. Close the end of the case by folding in this projecting part of the wrapper. To prevent the powder from sifting through the bottom, paste the folds, and press them on to the end of the stick, which is made slightly concave to give the bottom a form of greater strength and stiffness.

After the paste is allowed to dry, the former stick is inserted in the case, and laid upon the outer wrapper (the oblique edge from the operative, and the longer vertical edge towards his left hand) and snugly rolled up. The ball is then inserted in the open end of the cartridge, the base resting on the cylinder case, the paper neatly choaked around the point of the ball, and fastened by two half hitches of cartridge thread.

The former stick is then withdrawn, the powder is poured into the case, and the mouth of the cartridge is "pinched" or folded in the usual way.

To use this cartridge, tear the fold and pour out the powder; then seize the ball end firmly between the thumb and fore finger of the right hand, and strike the cylinder a smart blow across the muzzle of the piece; this breaks the cartridge and exposes the bottom of the ball; a slight pressure of the thumb and fore finger forces the ball into the bore clear of all cartridge paper. In striking the

cartridge the cylinder should be held square across, or at right angles to the muzzle ; otherwise, a blow given in an oblique direction would only bend the cartridge without rupturing it.

Cartridges constructed on these principles present a neat and convenient form for carrying the powder and ball attached to each other, and they obviate two important defects of the elongated ball cartridges in common use, viz : the reversed position of the ball in the cartridge, and the use of the paper wrapper as a patch. So far as they have been tried in the hands of the troops, they have been found to answer a good purpose.

ERRATA.

Page 25—Instead of "Remarks," read *Remarks on Sharpe's carbine.*

Page 31—Add the word *balls* at the end of last line.

Page 56—For "Haper's Ferry," read *Harper's Ferry.*

Page 80—In last line, instead of "60," read 260.

Page 94—Weight of rifle sword bayonet should be 2.15 lbs. instead of "3.05 lbs.;" consequently, the weights of rifles of 1841 and 1855 should be 11.83 and 12.03 lbs., respectively.

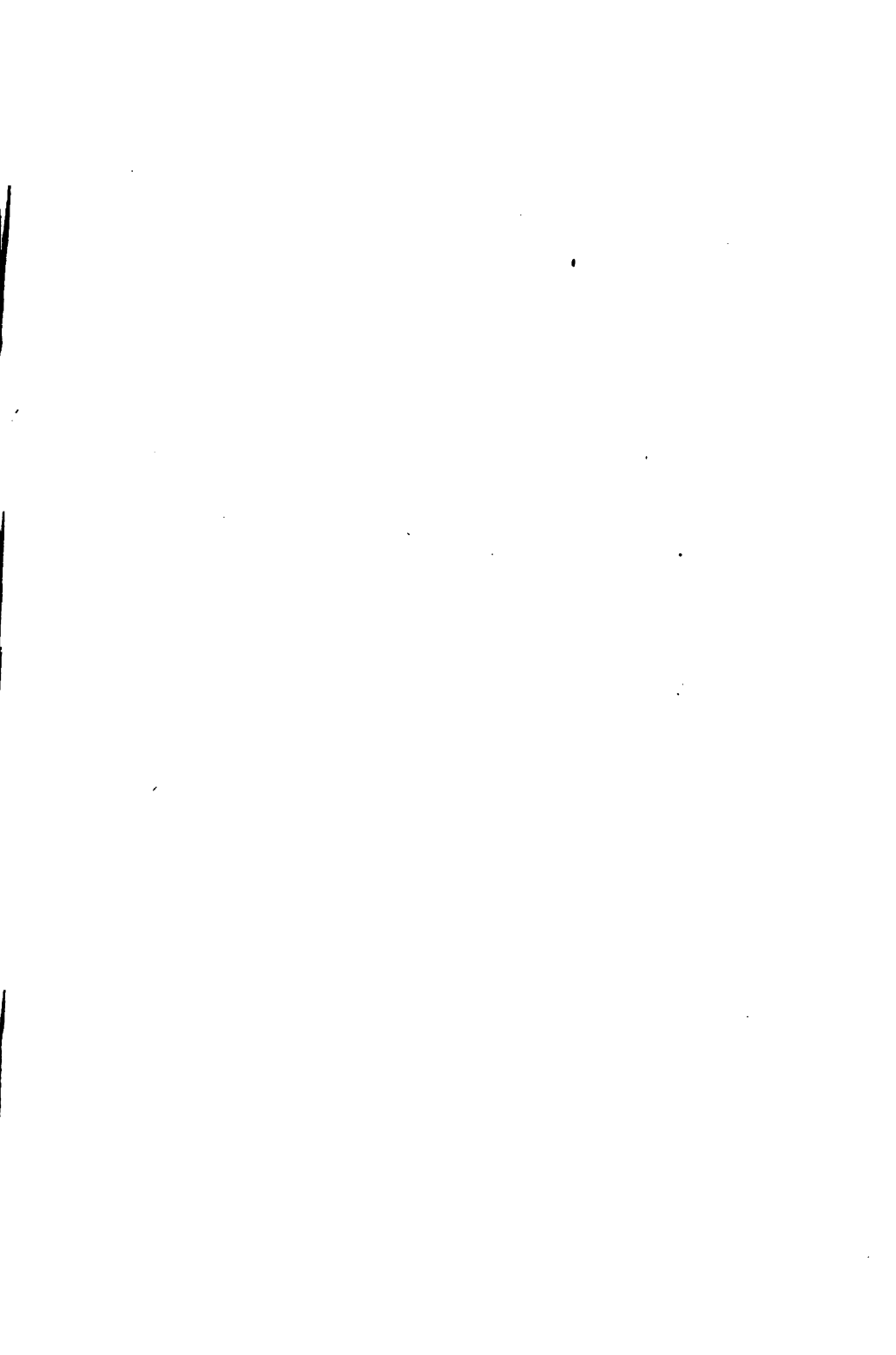



APPENDIX.

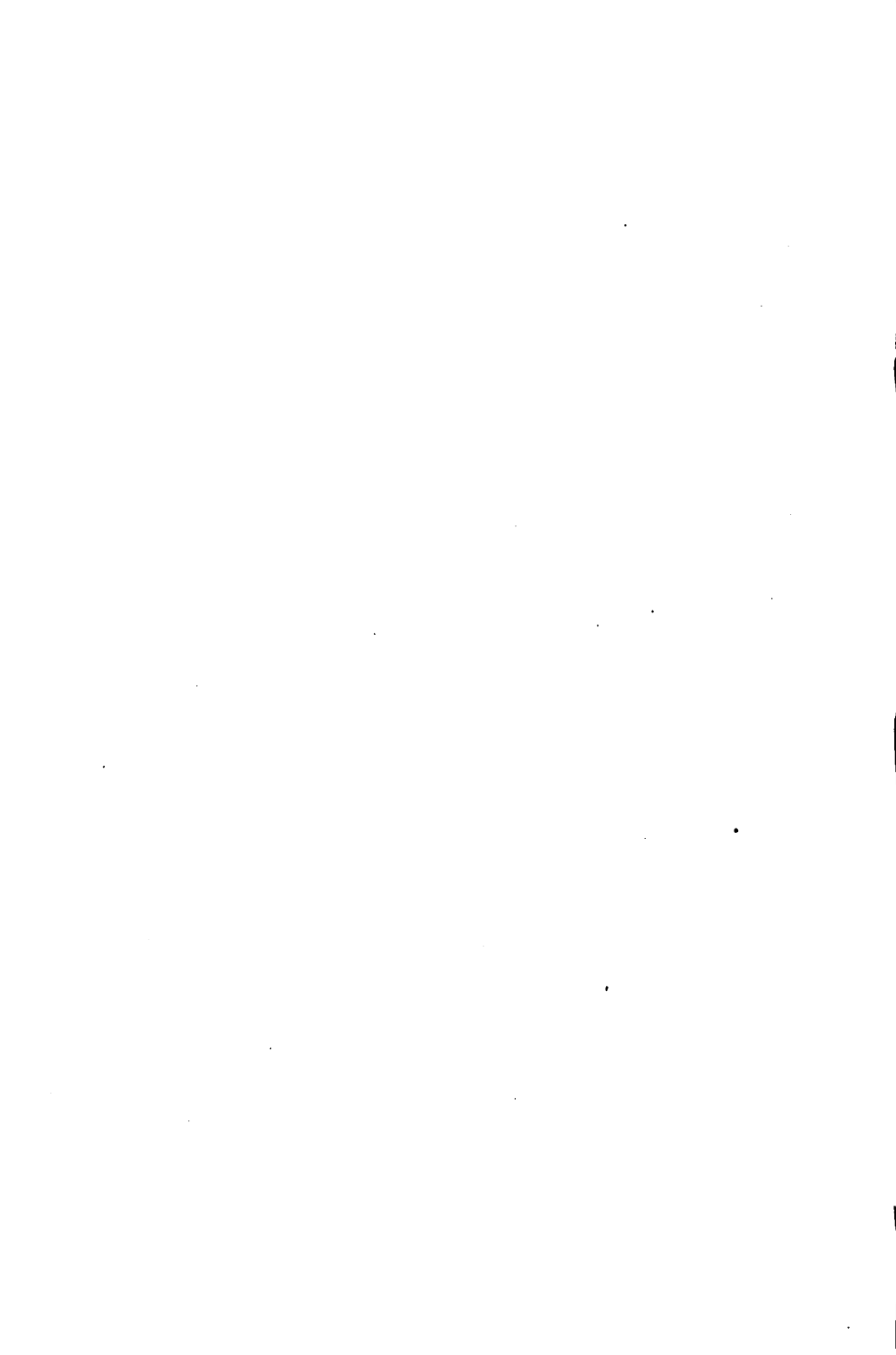

APPENDIX I.

EXTRACTS FROM THE WORK OF L. PANÔT, PARIS, 1851.

ON RIFLES.

One cause of the deviation of balls is the *windage*. By having no windage this cause is removed; and by giving, at the same time, a rotary motion to the bullet in the bore of the gun, which motion is retained during its flight, the accuracy of fire is much increased. Guns constructed to give a rotary motion to the projectile are known by the name of *rifles*.

METHODS OF DESTROYING WINDAGE.

1. *By loading at the breech.* This method was the *first* employed. Its first trials were made long since, and efforts are still making to perfect it, but not hitherto with success for weapons of war. The necessity of having a joint at the point of explosion of the charge has been a difficulty that mechanical ingenuity has not overcome.

2. *By loading at the muzzle, with the ball, without windage, and forcing it with a mallet.* This operation is too slow and inconvenient for service.

3. *By using a somewhat smaller ball, and filling the space between it and the bore with a patch.* This is the method that has been generally used with the most success; but still the loading is too slow and difficult to allow the rifle to be used to any great extent.

4. *M. Delvigné's plan of loading at the muzzle with a ball which enters free.* The powder is first placed in a chamber smaller than the bore, and the shoulder which joins the chamber to the bore supports the ball, which is struck with a heavy rammer, so as to enlarge it, and cause it to fill the bore.

5. *Captain Thouvenin improved upon Delvigné's plan by inserting a stem of steel, screwed into the middle of the breech-pin, around which the charge of powder is placed.* The ball enters free, and rests upon the top of the pin, which is tempered, and a few blows with a heavy ramrod forces it to fill the grooves.

6. *Captain Minié, to overcome the inconvenience of the stem projecting in the barrel, which renders the cleaning of the arm difficult, and is otherwise somewhat objectionable, has invented a bullet which is forced to fill the grooves by the action of the charge itself at the instant of its explosion.*

ON THE ROTARY MOTION OF THE BALL.

The rotary motion is given to the projectile by means of spiral grooves in the bore of the gun. A rifle has several of these grooves, and the ball being forced, fits into them, and at the discharge it is driven along them—thus receiving a rotary motion around its axis, which coincides with the axis of the bore. The barrel serves as the *nut* to which the ball acts as the *screw*.

The three principal points to be observed in the use and construction of rifles, and which must bear a proper relation to each other, are—

1. The charge of powder.
2. The inclination of the grooves.
3. The diameter and form of the ball.

The charge of powder is determined by experiment. It varies according to the calibre of the bore. If the charge is heavy, and the grooves have a great inclination, the ball being of a soft metal, will not follow the grooves, but will be forced across them, (or will *strip*,) and will leave the bore deformed in shape and without the rotary motion. If the grooves are not sufficiently inclined, the rotary motion would not be sufficiently strong to overcome the causes of deviation. With light charges, though the ball would follow the grooves, it would not have sufficient velocity to produce effect, especially with the spherical ball. The elongated or picket ball, in consequence of its form and weight, produces a greater effect.

There is then a relation between the strength of the charge and the inclination of the grooves. In proportion as the charge is large, the inclination should be slight; and as the charge is reduced, the inclination should be increased.

OF THE GROOVES.

1. Number of grooves. It is absolutely necessary to have two grooves—a single one would give a wrong direction. Some rifles are made with thirty-three grooves; others with even more; but experience has not determined exactly what is the best number.

2. Width of the grooves. The width must, to a certain extent, limit the number of the grooves. If there are many, they must be very narrow; if wide, there must be fewer. The small grooves are the most difficult to clean. It is found that, for small arms, the openings—that is, the sum of the grooves—should about equal that of the lands.

3. Depth of the grooves. This is only determined by experiment. If they are very deep, and the ball forced strongly into them, its surface would have projections upon it, which would form obstructions to its passage through the air, and produce an injurious effect. The grooves would cut away more than necessary of the barrel, and it would be very difficult to make the ball fill them.

The depth established in France is half a millimetre, (0.02 inches.)

4. Form of the grooves. A great many experiments have been made on this point, and have caused the rounded groove to be adopted. It has the advantage of not leaving such angular marks on the surface of the ball after being forced, and is not easily injured by the metallic head of the ramrod. They are, besides, more easily cleaned than square ones.

OF THE DIAMETER AND FORM OF THE BALL.

The windage should be as small as possible. It has been fixed at half a millimetre, (0.02 inch.) Knowing the diameter of the bore, that of the ball is given.

When spherical balls are used in rifles, only a very small part of the surface enters the grooves; and it is therefore more likely to *strip* under the same circumstances than the elongated or picket ball, a much larger surface of which is held by the grooves.

CONCERNING THE NUMBER OF GROOVES.

If, in a rifle barrel, there are an *even* number of grooves, the *spaces* are opposite to each other. When the ball is forced by being struck with the ramrod, it spreads and enters the grooves so as to fill them completely; and supposing the windage to be 0.02 inch, and each groove 0.02 inch deep, the ball will have to spread the amount of the windage and the depth of each groove, thereby increasing its diameter 0.06 inch.

If the number of grooves is *odd*, the lands are opposite the *spaces*. The ball, when rammed, will be forced by the land into the opposite groove; and with the windage of 0.02 inch, and depth of groove the same, it will have to spread only 0.04 inch to fill it. It thus appears an advantage to have the grooves an *odd* number.

ON THE INCREASED OR GAINING TWIST.

Rifles have been made with grooves that have *none*, or only a very slight inclination at the breech, and the twist is increased regularly until it reaches the muzzle. This is known as the *gaining twist*, and appears to be advantageous.

At the instant of discharge, when the ball, from a state of rest, is instantly given a high velocity, it would seem most likely to be pushed across the grooves, especially if the latter have a great inclination.

To avoid this shock at the instant of the discharge, the inclination of the grooves has been made nothing, or very slight at the breech, and increasing gradually towards the muzzle, at which point they are sufficiently inclined to give the necessary rotary motion.

It is doubtful whether this form of groove gives, in practice, the advantages we should expect. This may be owing to the change of form the ball must receive in its passage through the bore, which change may increase its liability to *strip*.

VARIATIONS IN THE DEPTHS OF THE GROOVES.

In order that the present muskets might be converted into rifles, Captain Tamisier proposed to vary the depths of the grooves, making them 0.02 inch deep at the breech, and decreasing gradually towards the muzzle, where it is 0.004 inch. Grooves thus made were found to have the great advantage of keeping the ball perfectly tight as it left the bore, and destroying all windage at the muzzle, besides not cutting away the metal at this thinnest part of the barrel.

OF THE RIFLE WITH THE STEM ("CARABINE Á TIGE") AND ELONGATED BULLETS.

The chamber of the Delvigné rifle of 1842 was omitted, and a plain breech-pin substituted, into the middle of which a cylindrical stem was screwed. When the breech-pin is in its place, this stem should be in the axis of the barrel.

This stem was made at first 1.417 inch in length; it projected into the barrel, and was screwed into the breech-pin 0.4 inch, and its diameter was 0.34 inch. The upper part, on which the ball rested, was flat. The grooves were four in number, and did not differ from those of the carabine of 1842, except in the length of twist. This was proposed to be one turn in 4.664 feet. The calibre was 0.689 inch.

The shape of the elongated ball required that the head of the ramrod should be reamed out to fit over it. The cavity was so made that when the ramrod was on the ball, the point of the latter touched the bottom of the countersink, the edges of which, and the head of the rod, were rounded off.

The hausse (breech sight) was graduated up to 1,421 yards. Without the bayonet, the weight of the arm was 10.15 pounds. The dimensions of the elongated ball are given in the drawings.* Its weight is about 1.65 ounce, and its diameter 0.676 inch. The length of the ball is reduced 0.085 inch by the operation of ramming to force it into the grooves. The charge of powder was 64.8 grains. Experiments prove that the cylindro-conical balls preserve their rotary motion during the length of their flight; even up to 1,421 yards they strike the target point first.

The initial velocity of the ball of the infantry musket is.	1,576.36 feet.
Wall piece, model 1840.....	1,240.00 "
Carabine á tige.....	1,023.60 "

*See plate attached to Part I.

This difference of initial velocity is caused by the different weights of the projectile and charge. The time of flight of the cylindro-conical ball for 1,421 yards is 7.70 seconds.

The "carabine á tige" fired with the conical balls combines, in a high degree, the two essential requisites of length of range and accuracy. It far excels all arms heretofore tried. The following table will give an idea of the great superiority of this arm over the wall piece of 1840, as to accuracy and penetration:

Comparative penetration of the Wall Piece of 1840 and the Carabine á tige, fired into targets of poplar plank 0.86 inch thick; the targets ranged one behind the other at 20 inches interval.

	Carabine á tige.					Wall Piece, 1840.				
Distance from the muzzle of the gun to the first target.	628 yards.					628 yards.				
Size of target	13 feet wide by 6½					13 feet wide by 6½.				
Number of shots fired.....	300					300				
Ranges of targets.....	1	2	3	4	5	1	2	3	4	5
No. of balls passed through.	124	109	89	73	33	10
No. of balls lodged	3	5	4	3	2	2	2
No. of balls indented.....	6	12	13	34	21	6
No. of balls that struck target	127					33				
The per cent. is.....	42.3					11.0				

At 1,421 yards the conical ball passed through two of these targets and indented the third. The velocity preserved by the elongated balls is the cause of their great penetration, and gives them great advantages at long ranges.

For cleaning this arm a wiper is required which will straddle the stem, and allow of being screwed to the end of the ramrod. To test the strength of the stem, one piece was loaded and the ball forced upon the same stem 4,800 times. A ball placed upon it was then struck one thousand blows with the ramrod by five men, each striking two hundred with their whole force. The stem received no injury.

The commission charged with experimenting with these arms proposed several modifications, which have been adopted.

The calibre was changed to 0.7 inch, and the twist changed from one turn in 4.664 feet to one turn in 6.56 feet.

The grooves, which had an uniform depth, were decreased in depth towards the muzzle. They were made 0.275 inch wide. The length of the tige was made 1.496 inch, and its diameter 0.354. The charge of powder was increased to 69.43 grains.

The ball was made with grooves, and was 0.676 diameter, and weighed about 1.65 ounce.

THEORY OF THE FLIGHT OF THE CYLINDRO-CONICAL BALL.

This elongated ball meets less resistance in its passage through the air than the spherical ball of the same calibre, especially when the latter has been flattened by being *forced*. This advantage is due to its pointed form.

The elongated balls being superior in weight to the spherical when fired from the same piece, do not lose their velocity as rapidly, and consequently, though their initial velocity be less, after a short flight their absolute velocity is greater than that of the spherical ball at that distance, which gives the elongated ball a greater penetration. This penetration is also increased by the pointed form of the front part of the bullet. It has been stated previously that the inclination of the grooves should be in proportion to the charge of the piece. The charge cannot be increased beyond a certain amount without loss of accuracy, as too large a charge would cause the ball to strip.

We know also that it is necessary to give the rifle bullet a rapid rotary motion as well as great velocity, which two motions cannot be carried to the same extent with the spherical as with the elongated bullet.

The elongated bullet does not decrease its velocity during its flight near so rapidly as the spherical, therefore it may have less initial velocity, and consequently may be given a greater rotary motion; besides, from the form of the cylindrical part of the ball a larger portion enters the grooves, and it is thus held more firmly in them and is not so likely to strip when these grooves have much inclination.

The elongated bullet first experimented upon had a groove around the bottom or cylindrical part. This groove was designed to attach the cartridge to, and to hold a greased ligature to act as a patch. A change having been made in the manner of attaching the cartridge to the ball, this groove was omitted as useless. The accuracy of fire was found to be diminished. The groove was replaced, and it was found by experiments that the slightest changes in its shape or position had much influence on the accuracy of fire. Not only any change of this groove,

but any alteration of the shape of the ball altered the results of the fire. This caused new examinations of the theory of its flight, all the effects of which it is yet impossible to appreciate.

M. Tamisier made experiments with a ball, the point of which, instead of being curved, was a cone, and the rest a cylinder; he varied the lengths of each part, and determined that these variations always produced variations in the accuracy of fire. These researches brought him to results of great importance.

The bullet during its flight describes a trajectory, which is a curve in a vertical plane, and the curvature of which is constantly changing. In order that the elongated ball should always have its point foremost, it must, as the curvature of the trajectory changes, change the position of its axis also, so as to coincide with a tangent to the trajectory.

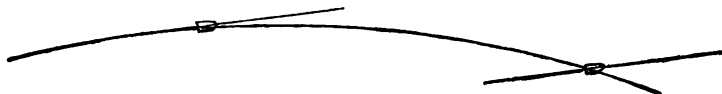

If the ball did not change its direction, but retained that in which it was projected, or in other words, if its axis remained parallel at the different parts of its flight to the position of the axis as it left the piece, the angle formed by its axis with the elements of the trajectory—that is, with the direction of motion—would change continually. The amount of the resistance of the air would vary with the amount of surface offered to it by the ball. The direction of this force would not always pass through its centre of gravity; it would therefore have a different rotary motion from that it had received from the grooves of the barrel. It is therefore necessary so to arrange the projectile, that the resistance it meets in passing through the air shall tend to keep it constantly on the curve of the trajectory.

M. Tamisier setting out upon the principle, that the greater the cause which tends to keep the axis of the projectile on a line with an element of the curve of its flight, the greater the accuracy, he came to a conclusion which gives a new aspect to the theory of projectiles.

He concluded, that to increase the accuracy of the elongated bullets, it was necessary to cause the greatest resistance from the air to act as far as possible behind the centre of gravity. He at first tried to carry this centre as far forward as possible, but in so doing, made the front part of the bullet too round, which caused an increased resistance to its passage through the air. Further researches caused him to employ another method to preserve the proper position, of the ball at each instant of its flight. This was to cause greater resistance of the air on the hind part of the ball whenever its axis did not coincide with the

direction of its motion. He made on the cylindrical part, instead of the single groove, heretofore used, as many grooves of 0.276 inch depth, as possible. The accuracy of fire was much increased.

Numerous experiments brought him to the conclusion, that it was proper to make the hind part of these grooves as sharp as possible.

The effect of the resistance of the air is illustrated by the spinning of a top, and the flight of an arrow. When a top is spun, its axis, though at first greatly inclined while it has a rapid rotary motion, raises itself by degrees, and ends by turning on its point, its axis vertical, and apparently standing still. The top is prevented from falling, and kept in an upright position, by the resistance of the air caused by its rapid rotary motion. The bullet, in its flight, has, in addition to the rotary motion of the top, a rapid forward motion.

The arrow has only a forward motion. Its greatest weight being nearest its head, the centre of gravity approaches that end. On the opposite end, feathers are placed, which, being very light, vary but little the position of the centre of gravity, but offer resistance to the air and prevent the arrow from descending, as it is impelled, by the force of gravity.

The feathers also prevent any rotary motion in a direction perpendicular to its axis, and keep the arrow in the direction of its flight, thereby causing the curve of the trajectory to be more flattened than it would be without them. The arrow being made long does not oppose a large surface, in proportion to its weight, to the resistance of the air. The grooves upon the elongated ball of M. Tamisier act, in preserving the direction of the bullet, in a manner in which we have shown the air to act in regard to the top and the arrow.

In the forward motion of the bullet, the grooves on its hind part have something of the effect of the feathers on the arrow, as the action of the air upon them tends to keep the ball from varying from its line of direction; and in the rotary motion, these grooves, like those upon the top, serve to increase the surface upon which the air acts. There is a particular motion in the elongated ball which is not yet perfectly explained, but of which we should give an account. The top, when first spun, revolves rapidly, with its axis greatly inclined, and does not raise itself immediately with an oscillating motion in a plane, but its axis describes a kind of spiral, while it becomes nearer and nearer the vertical. This may induce us to believe that the axis of the elongated rifle ball, which should change its direction at each instant, so as to coincide with the tangent of its trajectory, may have a corresponding motion to that observed in the axis of the top.

However rapid the motion of rotation, or spinning motion, which has the advantage of compensating for any irregularity in the form of the ball, and rendering it symmetrical around its axis, we can decompose this motion.

If the ball turns from left to right, the resistance of the air will be greater on

its right during its first half-revolution, and is irregular for the instant of time until it is equalized by the greater resistance on the left side during the other half-revolution.

The ball from this cause may, by the rotary motion, be made to describe a cone, and we may draw the conclusion that from the action of the air on it, while it has a rapid forward motion, it is probable, that the ball, instead of describing the plane curve known as its trajectory, describes a spiral around that curve without coinciding exactly with it.

OF THE "DÉRIVATION," OR DRIFT.

A constant and regular deviation was observed, which, for a long time, was attributed to windage, or the motion of the marksman's shoulder, which deviation M. Tamisier distinguished as the "dérivation."

It was found, at Vincennes, when it was perfectly calm, that with the first ball, (single grooved,) at distances over 328 yards, the shot struck to the right when the grooves of the barrel were from left to right; and the balls struck to the left when the barrels were grooved from right to left. The reduced twist, (one turn in 6.56 feet,) and the improved ball, having three grooves, adopted in 1846, decreased exceedingly the "dérivation," or it would have been necessary to adjust the sight to meet it.

The following table gives the "dérivation" at different distances with the rifle of 1842, with a twist equal to one turn in 4.37 feet, and single groove in the ball:

Distances, in yards. }	218		328		437		546		656		765		874		984		1093		1319		1421	
	ft.	in.	ft.	in.	ft.	in.	ft.	in.	ft.	in.	ft.	in.	ft.	in.	ft.	in.	ft.	in.	ft.	in.	ft.	in.
"Dérivations"...	0	4.75	1	1	1	9.25	2	0.25	4	9.50	7	6	11	6	16	1	21	11	38	4	50	6

In the rifle of 1846, with a twist of one turn in 6.56 feet, and the present ball, the "dérivation" is small, because the rotary motion is not so great as in the rifle of 1842.

What was the explanation of this phenomenon? The action of the wind is often the cause of lateral deviation, or the barrel being turned so that the breech sight inclines to the right or the left, causes the shot to strike on one side. The lateral deviations, which always occurred, were attributed at first to one or the other of these causes. But the same result was observed when it was perfectly calm, and when every care was taken to keep the sights in a vertical plane. Efforts were then made to discover the true cause.

An instrument having been so constructed as to determine the vertical plane of fire, it was found that these deviations always occurred in the direction of the

grooves. It was observed that they increased with the distance, not in a regular proportion, but in an increasing one, and they increased more as the inclination of the grooves, and, consequently, the rotary motion of the bullet was greater; and for the same distance with the same barrel they increased as the charge, or the initial velocity, was less.

The deviations could not arise from any motion of the piece, as it was fired from a rest which did not permit it to move, and, besides, if these deviations were caused by any inclination of the barrel, or incorrect pointing, they would have increased in proportion to the distance, and not in a greater proportion, as remarked.

These deviations must be caused by the rotary motion of the ball. But how are they caused? While the ball keeps point foremost the resistance of the air to its rotary motion is equal on all sides, and causes no "deviation;" but in the course of the trajectory, the ball, from its tendency to maintain its original direction, will vary from the curve described by its centre of gravity—the point will remain above and the larger portion of the ball below the curve of the trajectory. The forward motion of the ball causes a pressure of the air against it, which resists the rotary motion on its front or forward part. Now, if the ball in this situation revolves around its axis from left to right, there will be a greater resistance to the rotary motion on the part below the axis of motion than above it. This lower part will yield to the greater resistance, and the direction of the ball will incline to the right. When the grooves give a rotary motion to the left, the ball will go to the left.

This theory agrees with the practice which showed that the deviations corresponded with the direction of the grooves. The deviations arising from this cause have been distinguished by the term "*dérivation*," or drift.

The following is the result of trials made during a calm day, when no lateral deviation could be caused by the wind. The direction of the plane of fire was determined by an instrument made for the purpose; and the time of flight marked by a pendulum giving tenths of seconds. The single grooved ball was used:

Distances.	Mean dérivation.	Mean time of flight.
Yards.	Ft. in.	s.
546	2 9	1.86
765	9 9	2.97
874	11 6	3.67

The grooves added to the ball have the effect of counteracting the "dérivation," but do not entirely overcome it. They tend to bring back the axis of the ball upon the element of the trajectory, but it is by the resistance of the air on the lower part of the ball that it is thus brought back, and for the moment that the resistance of the air is not equal above and below, dérivation occurs. This dérivation is much less than with the single grooved ball, and need not be taken into account in practice. At 874 yards, with the single grooved ball, the dérivation is shown to be 11 feet 6 inches. With the grooved ball the dérivation at the same distance is not appreciable. It is observed that the dérivation is greater with small than with large charges: the time of flight is longer, and the ball is longer exposed to the disturbing force.

BALLS OF INCREASED LENGTH.

After M. Tamisier found that the grooves of the bullet had somewhat the effect of the feathers of an arrow, he tried balls of increased length, and found that he could fire with considerable accuracy, at long distances, balls longer than had been previously considered possible. M. Tamisier fired with accuracy balls of seven calibres in length. With the present rifle this equals 4.96 inches.

As these long balls do not increase the resistance of the air, they preserve their velocity, and reach great distances with accuracy, without having a great initial velocity, which allows us to give them a rapid rotary motion. The recoil and the strength of the barrel are the only limits to the length of the projectile. Rifles of a smaller calibre than the one adopted have certain advantages: they may have greater thickness and strength of barrel, without being too heavy; and, on account of this greater strength of barrel, they can fire a ball of greater length, and give it a rapid rotary motion. In these long bullets, the height of the cone may vary from 0.4 to 0.6 inch without seriously affecting the accuracy of fire. The depth of the countersink in the rammer head has been fixed at 0.47 inch. The point of the ball and the bottom of the countersink have both been rounded slightly. By this means the ball is not so apt to be deformed by forcing; the hollow in the head of the ramrod is more easily cleaned; and the ball-screw gets a better hold upon the forced ball.

Balls with one and two grooves have been experimented upon, and also balls with different depths of grooves; but all these experiments have shown that the ball now adopted is best.

ON THE VARYING DEPTH OF THE GROOVES OF THE RIFLE.

Two of these rifles, having four grooves each, were tried under exactly the same circumstances. Both were fired from a rest, at a target 656 yards distant. In one of them, the depth of grooves decreased from breech towards the muzzle; in the other, the depth of grooves was the same throughout.

	Grooves of decreased depth.	Grooves same depth.
	inch.	Inch.
Mean vertical deviation - - - -	17. 7	29. 13
Mean horizontal deviation - - -	17. 7	27. 55
Mean absolute deviation - - - -	27. 55	39. 76
Mean height of breech sight - -	1. 53	1. 45

The difference in the elevation of the sights may be attributed to the greater friction of the bullets in the barrel with grooves of decreasing depth. There is one disadvantage of the rifle á tige and ball, as now adopted, which should be noticed. This is the increased *weight of the ammunition*, owing to that of the ball. The men cannot carry as great a number of rounds in their cartridge boxes as formerly with the spherical ball.

TIMES OF FLIGHT.

The following table, showing the comparative velocities, at different distances, of the carabine of 1842, the wall piece of 1842, and the carabine á tige of 1846, gives us an exact idea of the superiority of this last arm over the others, although the initial velocity of the elongated ball is much less than that of the spherical ball fired from the other pieces:

Range.	TIME OF FLIGHT.			Range.	TIME OF FLIGHT.		
	Rifle 1842.	Wall piece 1842.	Rifle á tige.		Rifle 1842.	Wall piece 1842.	Rifle á tige.
Yards.	s.	s.	s.	Yards.	s.	s.	s.
165	0. 42	0. 46	0. 50	765	2. 97
218	0. 74	0. 75	0. 69	874	3. 67
328	1. 29	1. 37	1. 13	984	4. 35
437	1. 75	1. 73	1. 44	1, 093	5. 07
546	2. 64	2. 53	1. 86	1, 202	5. 81
656	4. 40	2. 37	1, 312	6. 71

We see that although the time of flight for 165 yards is less for the other two rifles than for the "á tige," yet at 218 yards, the ball of the latter gun retains a higher velocity, and this superiority goes on increasing rapidly for all the greater distances.

"BREACH SIGHT."

The breach sight (hausse) with sliding piece is of great advantage, as it can be adjusted to all distances, and it allows the marksman to correct the elevation whenever circumstances require it; but it has also the inconvenience of obliging him to move it whenever the distance varies, and consequently his line of sight is not adjusted for firing instantly. It is not suitable for firing in ranks. It increases the time required for preparing to fire, and adds a somewhat complicated piece to the arm.

The fixed sights of any fire-arm should be such, that, at short distances, the ball would strike the height of a man, aiming directly at his middle. The lowest sight has been fixed, therefore, to give a range of 165 yards. By turning down the sliding hausse, its base forms this sight, and a high projecting piece on the barrel is avoided.

It is difficult to adjust the hausses of different arms, so that their range shall correspond with the graduation of the hausse; these irregularities must be corrected by setting the sliding part as circumstances may require. As the hausse is more elevated, it becomes more necessary to hold the arm in such a manner that the sight shall incline neither to the right nor to the left, but shall be in the vertical plane passing through the centre of the barrel; for, should it incline to the left, the ball would go to a point to the left of the mark, and when inclined to the right, to the right of the mark. The range in both cases would be diminished.

MEAN DEVIATIONS OF CARABINE Á TIGE.

The annexed table gives the mean results of many trials made at Vincennes. The piece was loaded with as great regularity and care as possible, and was fired from a stand which held it at each discharge in exactly the same direction

Distances of the target.	Mean horizontal variation.	Mean vertical variation.	Distances of the target.	Mean horizontal variation.	Mean vertical variation.
Yards.	Inches.	Inches.	Yards.	Inches.	Inches.
165	4.72	5.11	656	21.26	22.04
218	7.87	8.26	765	24.40	29.52
328	11.02	11.81	874	29.52	39.37
437	12.59	13.77	984	37.40	59.51
546	17.32	17.71	1,093	49.21	82.67

The following effects have been observed in the practice of the troops armed with the "tige" arms, (Chasseurs à pied:)

1. The accuracy of firing depends much upon the manner of forcing the ball. It must be rammed sufficiently hard to cause it to fill the grooves. If rammed too hard the ball will be deformed in shape, and the range and accuracy will be diminished.

2. The "tige" renders the arm difficult to clean; in this operation the men should be practically instructed, as well as to extract the bullet with the ball screw.

3. The state of the atmosphere has an influence on the range, consequently the same mark on the breech sight will not always give the corresponding range. It has been observed from numerous experiments, made at Vincennes, that at distances over 547 yards, during damp and cold weather, the sights did not give the full range, but required to be raised a little.

4. The sliding part of the sight will sometimes not hold its place.

This may be often remedied without re-tempering it, by taking it apart and striking a number of light blows with a hammer on the inside to increase its curvature. This should never be done without taking it apart.

Cartridges for this arm are made in a particular manner; but it may happen that, in the absence of these special cartridges, it may become necessary to use musket ammunition, in which case the arm is loaded precisely as the musket. The ball is pushed home on the powder, *without ramming*, with the small end of the ramrod.

Up to 165 yards, aim directly at the object.

At 219 yards, aim at the object with sight for 273 yards.

At 328 " " " " " 437 "

At 437 " " " " " 601 "

The elongated ball has been tried with rifles having a smaller bore than the service rifle. Barrels were made having calibres of 0.55 inch, 0.51 inch, and 0.47 inch, and projectiles fired from them of lengths varying from $3\frac{1}{2}$ to 4 calibers long. The results differed but slightly from those obtained from the large rifle calibre used in service.

As the calibre is less, the inclination of the grooves should be increased, and the weight of the charge and projectile diminished.

ALTERATION OF SMOOTH-BORED ARMS.

The application of the tige allows the infantry musket, and all smooth-bored guns, to be easily changed into these rifles. It is but a few years since all the barrels of our small arms were reamed up so that they would carry the spherical ball of 0.669 inch diameter, instead of 0.641 inch. It is now to be regretted

that this was done, for there is every reason to believe that the cylindro-conical ball with grooves will be used for all small arms. To prevent weakening the barrels now reamed up to the calibre of 0.708 inch, M. Tamisier proposed, as before stated, to vary the depth of the grooves, making them deeper at the breech than at the muzzle: this has been found to increase the accuracy of fire, and has been adopted for all rifled arms.

Trials were made to test the strength of the musket barrel thus grooved. It was fired with the oblong ball and charge of 69.448 grains. It was then fired with 2, 3, 4, 5, 6, 7, and 8 cartridges placed one above the other. With 5 cartridges the hammer was raised to the safety notch, with 8 cartridges to the half-cock. The barrel was then washed and examined, and found to have received no injury. The firing was continued with 9, 10, 11, 12, 13, 14, and 15 cartridges, when the charge had not sufficient force to drive all the cartridges out of the barrel. The charge escaped out of the cone, and ten balls and ten charges of powder remained in the barrel. No part of the barrel or the tige was injured. It therefore appears that the musket barrel is sufficiently strong to be thus grooved, and there is no danger of its bursting in the hands of the soldier if he puts in several charges. The recoil alone would warn him of his error.

Numerous experiments were made at Vincennes with the infantry musket and "fusil à tige." The results of these experiments establish, in the most perfect manner, the superior range and accuracy of the "fusil à tige" over the musket.

Comparison of the infantry musket and musket altered "à tige."

Distances to and dimensions of target.		Infantry musket.	Infantry musket altered to the rifle & tige.	
164 yards.	}	Number of marksmen - - - - -	15	15
6 ft. 6 in.		Number of balls fired - - - - -	60	60
by		" " that struck target - -	18	37
1 ft. 10½ in.		Per cent. - - - - -	30.0	61.7
218 yards.	}	Number of marksmen - - - - -	15	15
6 ft. 6 in.		Number of balls fired - - - - -	60	60
by		" " that struck target - -	21	45
4 ft. 8.7 in.		Per cent. - - - - -	35.0	75.0
437 yards.	}	Number of marksmen - - - - -	15	15
6 ft. 6 in.		Number of balls fired - - - - -	60	60
by		" " that struck target - -	3	31
6 ft. 6 in.		Per cent. - - - - -	5.0	51.7
656 yards.	}	Number of marksmen - - - - -	..	15
6 ft. 6 in.		Number of balls fired - - - - -	..	60
by		" " that struck target - -	..	25
13 ft.		Per cent. - - - - -	..	41.7
874 yards.	}	Number of marksmen - - - - -	..	15
6 ft. 6 in.		Number of balls fired - - - - -	..	60
by		" " that struck target - -	..	14
19 ft.		Per cent. - - - - -	..	23.3

EXPERIMENTS ON PENETRATION.

The penetration was measured by firing through poplar plank targets placed one behind the other. The targets were one inch thick and twenty inches apart.

		Number of targets . .	1	2	3	4	5	6	7	8
437 yards. Infantry musket with spherical ball. 120 shots fired.	Balls which went through .		2	1						
	“ lodged . . .		2	0						
	“ indented . .		0	1						
	“ touched . .		4	2						
437 yards. Musket altered to á tíge rifle; oblong ball. 120 shots fired.	Balls which went through .		63	55	52	43	32	17	3	1
	“ lodged . . .		0	3	0	2	4	1	0	0
	“ indented . .		0	5	3	6	7	12	7	0
	“ touched . .		63	63	55	51	43	27	10	1
656 yards. Altered musket as above.	Balls which went through .		20	16	9	7	2	2		
	“ lodged . . .		0	1	1	0	0	0		
	“ indented . .		0	3	6	2	5	0		
	“ touched . .		20	20	16	9	7	2		
874 yards. Altered musket as above.	Balls which went through .		11	7	7	1	0			
	“ lodged . . .		1	1	0	0	0			
	“ indented . .		1	3	0	6	1			
	“ touched . .		13	11	7	7	1			

MEAN DEVIATION OF MUSKET ALTERED TO RIFLE Á TÍGE.

Experiments at Vincennes.—The ball rammed with as great care and regularity as was possible, and the piece fired from a rest.

Ranges.	Mean horizontal deviation.	Mean vertical deviation.	Ranges.	Mean horizontal deviation.	Mean vertical deviation.
Yards.	Inches.	Inches.	Yards.	Inches.	Inches.
164	5.90	6.30	546	19.29	20.86
279	9.44	9.84	656	24.40	26.37
382	13.00	13.77	765	30.31	35.43
437	14.96	16.14	874	37.40	47.24

OF THE MINIÉ BULLET (BALLES À OULOT.)

The rifle à tige, as a weapon, seemed brought to perfection, or in other words, the range, accuracy, and simplicity of this arm seemed as perfect as possible, when a new invention by Captain Minié gives us, not a greater range or accuracy, but greater simplicity in the construction and in the loading.

M. Minié, having often remarked the irregularity in forcing the ball in the "à tige" arms, notwithstanding all the precautions taken to prevent it, and that the cleaning of these arms required time and care; and, moreover, that in altering the musket the head of the ramrod had to be reamed out very much, or the rod replaced by a new one, conceived the idea of forcing the ball, by the action of the powder, at the instant of explosion. The bottom of the bullet is hollowed out, the opening having the form of a frustrum of a cone, and into this opening is inserted a piece of sheet iron, formed to act as a wedge, and spread the ball. The breech-pin is plain: the ball goes down free and rests upon the powder. When the charge is fired, the action of the gas on the sheet iron bottom forces it into the hollow of the ball, and spreads it into the grooves.

The ball is fired from the same rifle, the "à tige" being removed. For the calibre of 0.7 inch, with a charge of 76.15 grains, the cartridge is made in the same manner as for the "à tige" ball. The ramrod of the infantry musket answers to set the ball home. The hausse (guide) is similar to that of the "fusil à tige," and is graduated to suit the ranges.

In the month of June, 1849, these new balls were thoroughly experimented upon at Vincennes. All the comparative trials of this bullet and the elongated one with the "à tige" rifle were made firing off-hand at different distances.

The following table gives the results:

	Distances in yards.							
	164	273	382	437	546	656	765	874
	Mean variations referred to the mean point of impact of 100 shots fired.							
	Inches.	Inches.	Inches.	Inches.	Inches.	Inches.	Inches.	Inches.
Minié - - - - -	94.40	33.87	46.37	47.63	59.44	104.74	109.44	129.11
À tige - - - - -	94.80	38.90	59.37	48.03	69.68	115.35	137.40	137.40

The results show a superiority in all cases in favor of the Minié bullet, and this superiority increases with the distance, which may be caused by the ball being forced evenly by the pressure of the gas, independent of the care and skill of the marksman.

The graduation of the hausse for the Minié rifle was not quite as high, for the same distances, as for the "á tige."

The relative penetration of the two balls was tried by firing at targets of 1 inch stuff, with a space of 20 inches between them, at distances of 437, 546, 656, 765, and 874 yards. The mean results of the two varied but little, so that the penetrations may be considered as about the same.

To ascertain whether the ball, which is not forced into the grooves until the piece is fired, would remain in position and not be shaken out of the bore, the commission who tested it caused a platoon armed with the Minié rifle to use it in all the cases likely to occur in service.

They marched in double quick time over all kinds of ground; jumping ditches, climbing over walls, &c., and it was found that the ball did not move. The grease around the envelope at the lower end of the ball assists in keeping the latter in its place. They also found that the charge of powder was secure from wet and rain.

During these experiments, Captain Fanconpret, of the artillery, submitted to the commission a hollow ball without the sheet iron wedge. Although it was found that this ball was forced into the grooves, and was fired with some accuracy, it was far inferior to the ball with a sheet iron bottom.

ON THE HAUSSE (GUIDE OR BREECH SIGHT.)

The hausse, or breech sight, is a graduated piece attached to the barrel near the breech, which has a sliding piece retained in its place by a thumb screw, or by the spring of the slider itself. This slider should have an opening through which the gun can be conveniently aimed; and is raised to such a height as we think will give the necessary elevation for the distance.

To determine the height of this sight for a given distance, say 280 yards, the first shot is fired at a target placed at this distance. Upon this target draw two

lines through its middle, one horizontal and the other vertical. The point where these lines cross is the point aimed at. If the first shot is too high, or too low, lower or raise the slide, and continue to try until after some 8 or 10 shots are fired about the proper height, and all the balls are placed around the point B, and within a limited distance from it. Then remove the trial marks on the target, and try a certain number of shots, say twenty. Then measure off from

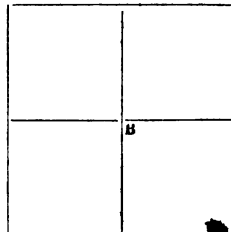

the target and note the vertical deviations, and we can determine the position of the mean vertical point of impact. If this position is 0. the height of the breech sight is correct, and need not be altered; if it should be found to be 7 inches above and 15 inches below, the breech sight is not high enough.

Suppose the vertical position of the mean point of impact of 20 shots fired is 15 inches below, and we will see how the breech sight should be altered.

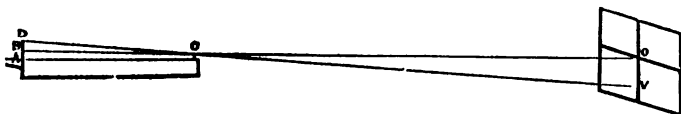

Let o be the point aimed at; AB height of breech-sight, obtained by experiment, as above; ov distance the ball falls, which we have supposed equal to 15 inches. Join the points o and v , prolonging the line ov until it meets the continuation of AB ; we then have $oo : BC :: ov : BD$. We measure on the barrel the distance from the front sight to the rear part of the breech sight, (hausse.) We find this length to be, say, 3 feet; we have 840 feet, (280 yards,) : 3 feet :: 15 inches : x .

$$x = \frac{3 \text{ ft.} \times 1 \text{ ft.} \cdot 25 \text{ in.}}{840} = 0.00446 = 0.05352 = \text{distance } BD, \text{ by which the}$$

height AB must be increased. If we know the fall of the ball in a given distance, the height to which the breech sight must be raised for any distance beyond a known one may be calculated in the same manner.

Knowing the dimensions of the gun, and of the height of its hausse for a certain distance, to determine the angle of sight for this distance:

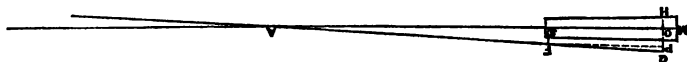

Suppose the line of sight passed through the hausse from the top of the sight F ; draw FF parallel to the line of fire, (i. e. axis of the bore,) the angle $GFF = G \Delta K$. Measure FF & GF from top of sight to rear part of hausse.

$$\text{Tan. } GFF = \frac{GF}{FF} \quad (\text{See table of natural lines, \&c.})$$

FF is measured on the barrel, $GF = GH - FH = GO - FS$; which are known or can be measured, from whence we determine GO .

Knowing either the angles of elevation, or the height of hausse, (tangent to the angles,) the trajectory of the projectile of this piece can be traced.

In the construction given, the line of fire is considered as the parallel to the axis of the bore drawn through the highest point of the sight:

1st From the angles of elevation.

For the carabine á tige, the angle of elevation for 219 yards is $57'$: for 328 yards, it is $1^{\circ} 28' 42''$.

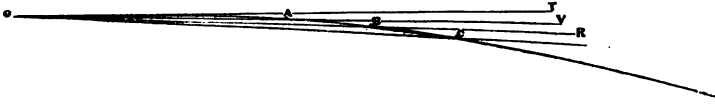

Draw the horizontal line $o\tau$, representing the line of fire. Make the angle $\tau o v = 57'$; and upon the line $o v$, take $o a = 219$ yards. The point a will be a point of the trajectory. From the point o draw $o r$, making the angle $\tau o r = 1^{\circ} 28' 42''$, and lay off $o b = 328$ yards. b , will be a second point of the trajectory. We proceed in a like manner for the other angles, until we have a sufficient number of points to trace the curve, making it tangent to $o\tau$ at o .

2d. Knowing the elevation of the hausse.

Instead of calculating the angles as explained, page 22, figure 2, we can lay them down. To facilitate our operation, we will multiply each side of the triangle $r o p$, by the same number, say 100.

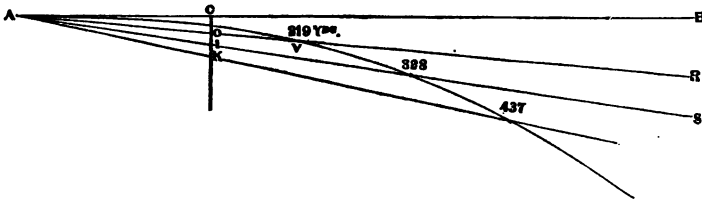

Draw ΔB , representing the line of fire. Take $\Delta c =$ to the distance from the hausse to the front sight, or a multiple of that distance.

At the point c , draw a perpendicular to ΔB , upon which lay off $c o =$ height of the hausse for 219 yards, or a multiple of that height. Draw Δo to r . From Δ lay off on $\Delta r =$ to 219 yards, and the point v thus obtained is one of the points of the trajectory. In a similar way we find the points for the distances of 328, 437, 547 yards, &c., in sufficient numbers to enable us to draw the curve.

CAUSES OF DEVIATION IN FIRING.

- | | | |
|--|---|---|
| (1.) From the construction of the arm. | { Causes which can be corrected.
{ Which cannot be corrected. | { Wrong position of the sight.
{ Calibre not exact.
{ Barrel imperfect.
{ Too hard on the trigger.
{ Windage.
{ The recoil.
{ Vibrations of the barrel, (spring of barrel.) |
| (2.) From the charge powder. | { Not exact measure.
{ Form of grain and variable quality of powder.
{ Its deterioration from dampness in transportation, &c.
{ More or less ramming.
{ Sticking along the bore, from becoming foul and damp.
{ Getting foul or dirty. | |
| (3.) From the ball. | { Not being of the exact weight and calibre.
{ More or less deformed in loading, or on leaving the barrel.
{ Not having the centre of gravity in the centre of the figure, (spherical ball.) | |
| (4.) From the atmosphere. | { The effect of wind.
{ The temperature; moisture in, and density of the air.
{ The position of the sun.
{ Difference of level between the target and gun. | |

APPENDIX II.

EXTRACT FROM REPORT OF EXPERIMENTS WITH SMALL ARMS, CARRIED ON AT ENFIELD, (ENGLAND,) 1852,

By the Hon. A. Gordon, Lieutenant Colonel. Published London, 1853.

These experiments were ordered by the Master General of Ordnance, (Viscount Hardinge.)

The following, principal gun-makers offered arms, which, as well as the Minié rifle, adopted in 1851, and the regulation two-grooved rifle, were experimented on, being fired from a frame arranged for the purpose. All the makers proposed bores and bullets as follows:

	lbs.	oz.	drs.
Mr. Purdey, 0.650 inch bore, or 17			
Mr. Lovell, .625 " 18			
Mr. Greener, .621 " 19			
Mr. Richards, .577 " 24			
Mr. Lancaster, .540 " 30			
Mr. Wilkinson, .530 " 31			

} balls to the pound.

WEIGHT OF DIFFERENT ARMS, AND THEIR AMMUNITION.

	lbs.	oz.	drs.
Regulation musket, including bayonet and scabbard - - - - -	11	11	0
Sixty rounds of ammunition - - - - -	5	7	7
	17	2	7
Brunswick, (two-grooved rifle,) bayonet and scabbard - - - - -	11	15	8
Sixty rounds of ammunition - - - - -	5	9	9½
	17	9	1½
Regulation Minié, bayonet and scabbard, (1851) - - - - -	10	13	12
Sixty rounds of ammunition - - - - -	6	12	2
	17	9	14
Mr. Wilkinson's new rifle, bayonet and scabbard - - - - -	9	9	4
Sixty rounds of ammunition - - - - -	4	15	12
	14	9	0

Distances to first graze when these rifles were fired, bores perfectly horizontal, and elevated 4 feet 7½ inches above the place on which they struck; or distances in which the balls fell 4 feet 7½ inches:

	yds.	ft.	ins.		yds.	ft.	ins.
Lancaster - - - - -	194	0	11	Regulation Minié - - - - -	177	1	7
Lovell, (heavy ball) - - -	190	0	5	Lovell, (light ball) - - -	176	1	6½
Wilkinson, (naked ball) 185	0	3	¾	Brunswick rifle - - - - -	173	0	2½
Purdey, (plug ball) - - -	180	2	4	Wilkinson, (cartridge) -	172	1	5½

REGULATION MINIÉ.—Weight with bayonet, 10 pounds 8¾ ounces.

Barrel.—4 pounds 10 ounces; length, 3 feet 3 inches; diameter, .702 inch.

Grooves.—No. 4; twist once in 6 feet 6 inches.

Charge.—Powder 2½ drachms F. G.

Bullet.—Minié, diameter, .690 inch; length, 1.03 inch; weight, 680 grains.

Angles of elevation, for 100 yards, 0° 14'; 500 yards, 1° 51'.

for 200 yards, 0 39; 600 yards, 2 23.

for 300 yards, 0 53; 700 yards, 3 05.

for 400 yards, 1 22; 800 yards, 3 25.

The first bullet was conical; a new bullet, cylindro-conoidal, was tried in 1852, and found much superior.

The question of the number of grooves has been carefully considered, and three grooves have been found superior to *four*, both as regards accuracy of shooting and horizontal trajectory. An odd number of grooves is preferable; for when a groove is opposite a land instead of opposite a groove, the ball is more easily expanded with less disturbance of the lead.

Grooves with only one side have been tried, but the experiments have not been sufficiently extensive to allow a decided opinion on them being given.

The present bayonet spring is defective. The "locking ring" like the French seems better.

The objection to the ramrod spring is, the wearing out of the threads of the screw on end of ramrod. A swell on rod eight inches from the head is proposed. The round-head rod seemed to be used altogether, and the bullets are all rounded on the top, though not near as sharp as the French "*à la tige*." The use of bands instead of loops and pins is proposed. The "swivel lock" is adopted, and is a great advantage over the "hook lock" so long retained in the British service.

WILKINSON'S RIFLE.—Weight with bayonet, 9 pounds 5 ounces.

Barrel.—Weight, 4 pounds 1 ounce; length, 3 feet 3 inches.

Bore.—Diameter at muzzle, 0.530 inch; at breech, 0.531 inch.

Grooves.—Five; twist one turn in 6 feet 6 inches.

Charge.—Powder, 2½ drachms F. G. = 68 grains.

Bullet.—Solid expanding; diameter, .537 inch; length, 1.075 inch; weight, 500 grains.

Angles of elevation, for 100 yards, $1^{\circ} 14'$; 600 yards, $2^{\circ} 00'$.
 for 200 yards, $0^{\circ} 28'$; 700 yards, $2^{\circ} 29'$.
 for 300 yards, $0^{\circ} 47'$; 800 yards, $2^{\circ} 44'$.
 for 400 yards, $1^{\circ} 05'$.
 for 500 yards, $1^{\circ} 25'$; 1,000 yds., $4^{\circ} 31'$.

This ball is intended to be used without patch or paper, the grooves being filled with grease.

The cartridge containing the powder is put into the barrel before the ball is taken out of the ball pouch. The muzzle of the barrel is countersunk, which is a great convenience in loading. The balls are heavier, but 60 rounds of ammunition (as above) weigh less than 60 rounds percussion musket ammunition.

The accoutrements are to be arranged to carry the cartridges in a pouch separate from the balls. If the military authorities are satisfied with the system, that has been in use in our rifle brigades for the last fifteen years, viz: that of having the powder cartridge separate from the bullet, it is recommended to give this arm a further trial in the rifle regiments.

There was no difficulty in the loading. On a very hot day, thermometer at 130° in the sun, in 30 minutes, the following number of rounds were fired with balls:

Wilkinson 65; Lancaster 65; Regulation Minié 60; Purdey 56. None became foul, though too hot to be handled conveniently.

At another time, during a heavy rain, Wilkinson's and Lancaster's rifles were fired 100 rounds in 36 minutes, the hundredth round being loaded as easily as the first.

The grease on the bullets makes rather dirty work for the hands; but this is no objection.*

* NOTE.—A few trials were made at the Washington arsenal for the purpose of comparing the accuracy of fire of the Wilkinson ball with that adopted into our own service; both balls were fired from the same gun, an altered Harper's Ferry rifle, under circumstances as nearly alike as possible. The Wilkinson ball tried in these experiments was a solid expanding ball, weighing 690 grains; charge of powder 60 grains; target 10 by 10 feet; fired from a shoulder and rest.

No. of shots.	Distance.	Mean vertical deviation.	Mean horizontal deviation.	Balls missed target.		Date.
	Yards.	Inches.	Inches.			1856.
10	200	7.3	10.	Wilkinson ball.	July 23
10	200	7.1	8.2	1	Wilkinson ball.	July 24
20	Mean..	7.2	9.1			
10	200	5.	4.1	American ball.	July 23
10	200	6.7	6.9	American ball.	July 24
20	Mean..	5.8	5.5			

LANCASTER'S RIFLE.—Weight with bayonet, 9 pounds 9 ounces.

Barrel.—Weight, 4 pounds 14 ounces; length, 3 feet 3 inches.

Bore.—Smooth and elliptical.

Major axis, .550 inch diameter at muzzle; .557 inch at breech.

Minor axis, .540 inch diameter at muzzle; .543 inch at breech.

Grooves.—Elliptical, having an increasing spiral.

Charge.— $2\frac{1}{2}$ drachms F. G.

Bullet.—Expanding by a plug; diameter, 0.532 inch; length, 1.125 inch; weight, 542 grains.

Angle of elevation, for 100 yards, $0^{\circ} 11'$; 500 yards, $1^{\circ} 34'$.

for 200 yards, 0 26; 600 yards, 2 02.

for 300 yards, 0 49; 700 yards, 2 32.

for 400 yards, 1 09; 800 yards, 3 01.

The peculiarity of this gun is having the bore elliptical, which thus answers as grooves.

Mr. Lancaster has adopted the American plan of a "gaining twist," or "increasing spiral," and applied it to his smooth bored barrels with elongated projectiles.

The author discusses the merits and disadvantages of the gaining twist, and concludes *against* it, especially for elongated projectiles, and says: "The spherical ball, or conical picket, used by the Americans with their gaining twist, is not so likely to be deformed by the change of twist as elongated projectiles. In fact, a smooth bored rifle, (on Lancaster's eccentric plan,) made with a regular twist, was found to shoot better than Mr. Lancaster's with the gaining twist, although the barrel of the former was 0.3 inch (.03 inch?) larger, and the bullet 50 grains lighter than his.

The plug bullet used by Mr. Lancaster does not appear suitable for military service. The paper of the cartridge gets between the plug and bottom of ball, and the plugs do not in all cases remain firmly attached to the bullet. The advantages of this method of grooving over the ordinary do not appear of any consequence.

The plug bullets are objected to: if the plug should be driven in too far, the bullet would not go down, which makes it very desirable that a bullet intended for military service should be of a simple form of solid lead, requiring neither cap or plug.

An objection is made to bores of the size of Mr. Lancaster's and Mr. Wilkin-son's, that the powder and bullet cannot be connected in a cartridge, as it is feared from its shape that it would not stand the wear and tear of carriage in the men's pouches, without injury. The length is $3\frac{1}{4}$ inches and the diameter only $\frac{1}{16}$ inch; consequently, the leverage of a bullet weighing 542 grains, as the end of so slender

a cartridge, will, it is imagined, be such as to loosen and break the paper at the neck, causing the powder to get in between the cases, or to escape. In fact, all the cartridges made up as at present in order to reverse as for the Minié or other expanding bullets, some powder was generally found to have made its way out of the paper case, and sometimes it was found in the outer wrapper of the whole bundle, although this ammunition had only been subjected to transportation from Woolwich to Enfield. For these balls, there should be great exactness both in the charge, and in the dimensions of the ball. This question, however, of the durability of the cartridge, can only be satisfactorily ascertained by being carried in wagons, and in the pouches of the men of a marching regiment, for two or three months.

Another defect in using cartridges in a hurry, is, in biting off the end, the paper closes, and all the powder is not poured out into the barrel. This occurred in trials of rapidity of fire.*

PURDEY'S RIFLE.—Weight with bayonet, 9 pounds 1½ ounce.

Barrel.—Weight, 3 pounds 15½ ounces; length, 3 feet 3 inches.

Bore.—Diameter, 0.650 inch.

Grooves.—Four; gaining twist, commencing with one turn in 6 feet, and ending with one in 4 feet 6 inches.

Charge.—2½ drachms F. G.

Bullets :—

	Minié.	Plug.
Diameter,	0.643 inch;	0.643 inch.
Length,	.910 inch;	1.050 inch.
Weight,	487 grains;	610 grains.

Angles of elevation for plug bullet,	{	for 100 yards, 0° 15'; 500 yards, 1° 47'.
		for 200 yards, 0 40; 600 yards, 2 21.
		for 300 yards, 0 57; 700 yards, 2 58.
		for 400 yards, 1 17; 800 yards, 3 41.

This is a very beautifully constructed arm—a light weapon, with a *large* bore and light projectile. The bullet being lighter, the trajectory was higher than with the other bullets; but, notwithstanding, it made very accurate shooting. There appears no advantage in making the plug of hard metal; it seems best when made of lead. This plug answers better than Lancaster's, as from the form it does not nip the paper. The remarks already made on the gaining twist apply here.

LOVELL'S MINIÉ RIFLE.—Weight, with bayonet, 9 pounds 1½ ounce.

Barrel.—Weight, 4 pounds 1½ ounce; length, 3 feet 3 inches.

* NOTE.—I think cartridges can be made to overcome these objections.—B. H.

Bore.—Diameter, .635 inch.

Grooves.—Four; one turn in 6 feet 6 inches.

Charge.— $2\frac{1}{2}$ drachms F. G.

Bullets.—Minié; two patterns—

Diameter, No. 1, .630 inch; No. 2, .628 inch.

Length, No. 1, 1.145 inch; No. 2, .948 inch.

Weight, No. 1, 686 grains; No. 2, 562 grains.

	Heavy ball.	Light ball.
Angles of elevation, for 100 yards,	0° 11'	0° 14'
200 "	0 26	0 26
300 "	0 49	0 52
400 "	1 09	1 18
500 "	1 34	1 47
600 "	2 02	} Too wild to give a correct angle.
700 "	2 32	
800 "	2 50	
1,000 "	4 16	

This is the same pattern gun as the regulation Minié, but of smaller dimensions.

The heavy ball made excellent shooting at all distances, but the difficulty of loading and the great weight of this ball render it quite unfit for troops of the line. It was difficult to load sometimes with a strong wooden rammer.

The light ball, at times, made very good shooting up to 400 yards; but after firing a dozen shots, it sometimes became wild and uncertain. The difficulty of loading was the same as with the heavy ball.

Two new bullets were afterwards prepared, which loaded easier; but the heaviest, weighing 360 grains, is the best.

THE BRUNSWICK RIFLE.—Weight, with bayonet, 11 pounds $5\frac{1}{2}$ ounces.

Barrel.—Weight, 3 pounds 14 ounces; length, 2 feet 6 inches.

Bore.—Diameter, 0.704 inch.

Grooves.—Two; one turn in 2 feet 6 inches.

Charge.— $2\frac{1}{2}$ drachms R. A.

Bullet.—Spherical; belted; diameter, .696 inch; weight 557 grains.

Angles of elevation, for 100 yards,	0° 08'
200 "	0 34
300 "	0 54
400 "	1 26
500 "	} Too wild to give a correct angle.
600 "	
700 "	
800 "	

This rifle has shown itself to be very much inferior in point of range to every arm hitherto noticed.

The loading of this rifle is so difficult, that it is wonderful how the rifle regiments can have continued to use it so long, the force required to ram down the ball being so great as to render a man's hand much too unsteady for accurate shooting.

MR. GREENER'S RIFLE.—Several were submitted, with seven different projectiles; but they did not answer to his expectation.

NEW ENFIELD MUSQUET (RIFLE.)—Weight, with bayonet, 9 pounds 3 ounces.

Barrel.—Weight, 4 pounds 2 ounces; length, 3 feet 3 inches.

Bore.—Diameter, 0.577 inch.

Grooves.—Three; one turn in 6 feet 6 inches; width, 0.262 inch; depth, 0.014 inch.

Charge.—Powder, $2\frac{1}{2}$ drachms, F. G. = $61\frac{1}{2}$ grains.

Bullet.—Solid expanding; diameter, 0.568 inch; length, 0.960 inch; weight, 520 grains.

	lbs.	ozs.	drs.
Weight of rifle, including bayonet - - - - -	9	3	0
Sixty rounds ammunition - - - - -	5	3	11
	14	6	11
Add for bayonet scabbard - - - - -	0	4	8
	14	11	3

Trajectory of the Enfield rifle at one hundred yards—

Distance from muzzle - - - - -	50	75	100	yds.
Height of bullet* - - - - -	9	$6\frac{1}{2}$	0	ins.

Two hundred yards—

Distance from muzzle - - - - -	50	75	100	125	150	175	200	yds.
Height of bullet* - - - - -	$11\frac{1}{2}$	$14\frac{1}{2}$	19	21	$20\frac{1}{2}$	$10\frac{1}{2}$	0	ins.

Three hundred yards—

Distance -	50	75	100	125	150	175	200	225	250	275	300	yds.
Height* -	$17\frac{1}{2}$	$26\frac{1}{2}$	33	$40\frac{1}{2}$	$42\frac{1}{2}$	43	39	32	24	14	0	ins.

When the experiments were finished, in August, 1852, two "musquets" were made at the Royal manufactory at Enfield, in which were embodied the improvements and alterations suggested by the experience obtained during the course of the trials with the experimental arms, and which, it was hoped, would possess the

* The lower lines of figures indicate the height of the bullet above the line of aim, at the distance from the muzzle given in the upper lines.

necessary requirements for a military weapon on the Minié system. The weight and description are already given; the barrel to be fastened to the stock by three bands; the ramrod to have a swell near the head; the bayonet to be fixed by means of the locking ring; the lock to be made with a swivel; one arm to be made with a block-sight for 100 yards, and two leaves for 100 and 200 yards, in addition to the block-sight. This is proposed for troops of the line, militia, &c.

The other, with a block-sight (as before,) and a modification of Mr. W. Richards' sight, calculated for use up to 800 yards, is recommended. It can turn either way and lay flat on the barrel; and is not likely to be injured by transportation, as one always projecting. This is proposed for the rifles and picked men of other corps.

Gunpowder for the expanding balls appears to be best when its explosion is not too instantaneous. The size of the grain appears to be of importance; better shooting being generally obtained with large than with fine grained powder. The larger grain is in other respects most advantageous. It has been generally found that the ordinary government F. G. powder, which can be made for sale at an expense of 10d. per pound, is quite as well suited for accurate shooting with expanding bullets as that which is sold for 2s. 6d. per pound with fancy names, as "Diamond," "Glass," &c.

Mr. Pritchett, a gun-maker of London, was requested to adapt to the bore of this "musquet" a projectile, without cup or plug, which he had been recently trying with great success.

The shooting of these "musquets," with this bullet, at distances up to 800 yards, was found to be superior to any that had yet been tried, when loaded according to the usual Minié style, with greased cartridges, reversing the bullet. They were also tried with the same bullet as before, made up into cartridges, loading without reversing, like the old spherical ball. The shooting was tolerably good, but the barrels fouled immediately above the powder for about two inches.

In conclusion, it is to be observed, that the experiments alluded to in the foregoing remarks were ordered by Lord Hardinge, for the purpose of obtaining, if possible, a lighter and a better "musquet" than that in use by the army when he became major general of the ordnance in 1851. His predecessors at the horse guards and the ordnance office, having previously sanctioned the change of system from that of a smooth bore with spherical balls to that of Captain Minié's, viz: one of rifled barrels with greased expanding bullets, and reversing the cartridge, making, however, with this change, no abatement of the weight to be carried by the soldier, but, on the contrary, a slight addition; for although the weight of the "musquet" itself was slightly reduced, the increased weight of the Minié bullet caused an increase of about half a pound in the total weight of "musquet" and sixty rounds of ammunition.

The only way here suggested for reducing the weight, was by reducing the number of rounds; but this was objectionable, as that number has been found necessary and expedient.

This, being the design of the major general, was the object attempted to be attained; and the author is of opinion that the object has been successfully attained, for a new rifled "musquet" has been produced which possesses the following advantages:

1. A saving in weight of about three pounds for every soldier has been effected, although the new bullet itself is thirty grains heavier than the old spherical ball.
2. The sixty rounds for each man have been retained.
3. The strength of the musquet has been very much increased.
4. The accuracy of shooting of a musquet which only costs (without bayonet) about £2 10s., has been improved; so that, at the distance of 300 yards, a good marksman can generally hit a bull's eye with a six-inch radius.
5. The manufacture of the projectile has been very much simplified; the Minié bullet, originally adopted with the Minié musquets, having been altered from an inconvenient form, and a compound of lead and iron, requiring great care in the preparation, to a simple form of lead only.
6. An indirect advantage of the new rifled musket is, that any of the improvements, that are constantly being made in the form and composition of elongated projectiles, will be more easily adapted to a barrel of this diameter than to one of the former size.

This being the state of the case, it now rests with the military authorities to decide how far the Minié system can with safety be adopted by the army.

The improvements which have been suggested in the pattern of the "musquet," viz: the swivel lock, locking ring for the bayonet, bands instead of loops, and pins, &c., are, if found to be advantageous, equally applicable to the old smooth bore musquet, as to those made for the new Minié system.

The accompanying extract is taken from General Sir Howard Douglas's Treatise on Naval Gunnery, 1855, viz:

The following table, kindly communicated by Colonel Hay, on the subject of rifle practice at Hythe, shows the comparative accuracy of shooting at different distances, with the common percussion musket of 1842, and the rifle musket of 1851; the former carrying a spherical bullet, and the latter the regulation Minié shot, (a cylindro-conical projectile.)

Twenty men fired ten rounds each, five in file and five volley firing, against a target 6 feet high and 20 feet broad, equal in front to 11 file of infantry, or 22 men. The muskets were 4 feet 6 inches from the ground:

PERCUSSION MUSKET, 1842.

Distances.	Number of hits in the—			Hits.	
	Bull's eye.	Centre.	Outer.	Total.	Per cent.
Yards.					
100	7	48	94	149	74.5
200	3	20	62	85	42.5
300	4	9	17	32	16.
400	2	..	7	9	4.5
MINIÉ RIFLE MUSKET, 1851.					
Distances.	Number of hits in the—			Hits.	
	Bull's eye.	Centre.	Outer.	Total.	Per cent.
Yards.					
100	10	68	111	189	94.5
200	9	47	104	160	80.
300	6	32	72	110	55.
400	5	29	71	105	52.5

Colonel Hay remarks, that the shot from the common musket which missed the target, fell from 20 to 50 feet wide of it; whereas the Minié shot which missed fell within two or three feet only of the target. The same officer, in a letter to the author, observes that, with careful training, soldiers of the line may be made to put half their shot into such a target at 400 yards, and two-thirds at 300 yards.

September 17, 1853, at Hythe, practice was made with the regulation Minié musket by four men, each of whom fired ten rounds, at distances from the target varying from 700 to 200 yards. The target was 16 feet long and 6 feet high.

The men advanced in skirmishing order, according to regulation; fired kneeling, and exercised their own judgment respecting their distances from the object. Of the 40 rounds fired, 8 hits took place in the bull's eye; 16 in the central part (a circle 6 feet in diameter) and four feet beyond, but very near the central part; in all, 28 hits, and 12 misses. Of the hits, 18 were below the centre, and 10 above; 16 were on the right, and 12 on the left. The wind was blowing strongly,

and the atmosphere was cloudy. The same day similar practice was made by four men with the musket having an elliptical bore, at the same distances from the target, the men advancing in skirmishing order and kneeling. Of 40 rounds fired, 6 hits took place in the bull's eye; 22 in the centre circle, and 6 beyond it; six shots only missed the target. Of the hits, 25 were below the centre, and 9 above; 15 on the right, and 19 on the left.

* * * * *

On comparing the shooting from a rest with that from the shoulder, it was found, 100 rounds being fired in each of the two ways, that a column of men consisting of 13 files in front, would receive 79 hits from the rests, and 54 from the shoulder.



APPENDIX III.

A set of the small arms lately introduced into the Austrian service, consisting of two rifle muskets for the infantry of the line, and two carbines with sword bayonets for the chasseurs, was lately brought home by a board of army officers. A few trials were made at the Washington arsenal with one of these arms, an infantry musket; the results of which are given in the accompanying table.

The calibres of all the arms are the same, viz: .55 inch—nearly that of our late regulation rifle. The length of the musket barrel is 37.5 inches; it weighs about 4.25 pounds, and is rifled with four grooves of uniform depth and twist. The gun, with its bayonet, entire, weighs about 10.25 pounds.

The ball was a solid expanding one, similar in its construction to that of Mr. Wilkinson's, and weighed 450 grains; the charge of powder weighed 62 grain. Both ball and powder were put up in the form of a cartridge with the position of the ball reversed; the paper of the ball end of the cartridge was saturated in grease, and accompanied the ball into the gun, serving as a patch.

No. of fires.	Distance.	Mean vertical deviation.	Mean horizontal deviation.	No. of shots missed.	Target 10 by 10 feet.
	Yards.	Inches.	Inches.		
23	300	15.5	12.1	6	July 10, 1856



