

RESEARCHES  
INTO INDUCED  
CELL-REPRODUCTION  
IN AMŒBÆ

VOL. IV.

THE MCFADDEN RESEARCHES

shulov

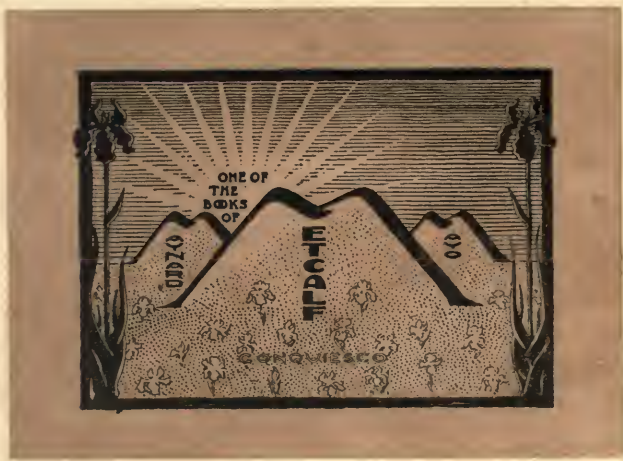

MBL/WHOI



0 0301 0015820 0



RESEARCHES INTO INDUCED  
CELL-REPRODUCTION IN AMŒBÆ

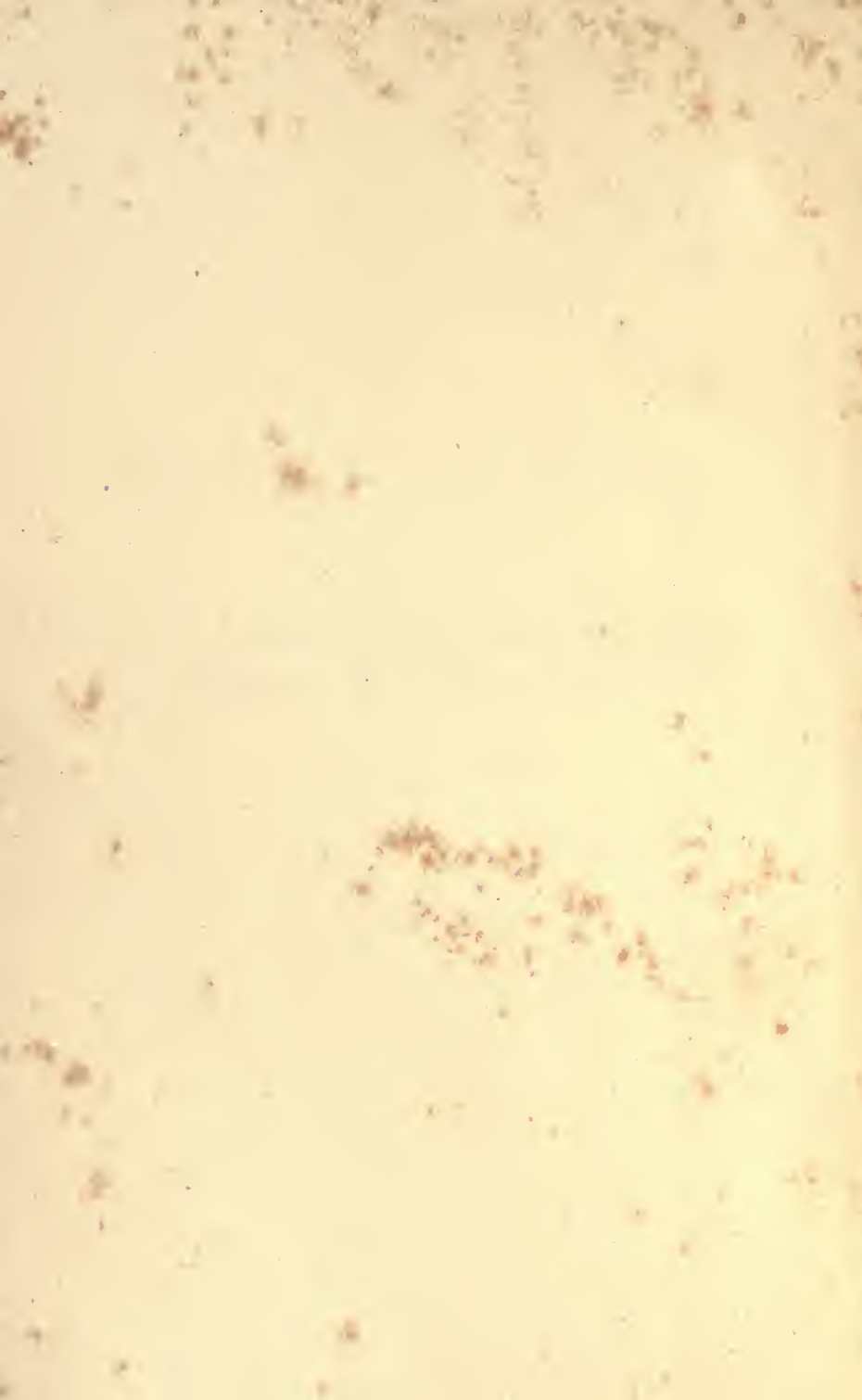





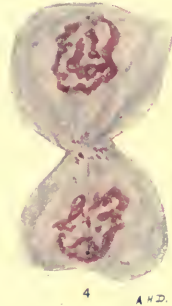
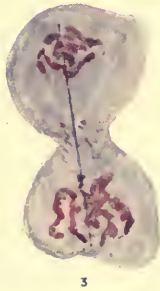
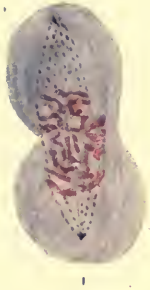



# MEMOIRS OF THE LIFE OF JOHN DEWEY

BY  
ALICE DEWEY

NEW YORK: HOUGHTON MIFFLIN COMPANY, 1915.

MADE IN U.S.A.

LONDON:

HOUGHTON MIFFLIN COMPANY, 25 ABINGDON STREET, E.C. 4.

1915.

PRINTED BY

Successive stages of nuclear division seen in one living amœba which was stained by the jelly method when actually alive and about to divide. The nucleus only is represented ; it was drawn from life by the camera-lucida. Amœbæ differ from any other cells yet tested in that they will continue to live for a few minutes with the nuclear chromatin stained. It is believed that these figures are the first that have been seen of a nucleus of a living cell passing through the stages of division with the parts stained artificially.

The amœba came from a strain different to *A. ostrea* ; it has a coefficient of diffusion of about 16, and seems more resistant to stain. It had been growing on jelly containing the auxetic tyrosine, and it was immediately after its transference from that jelly to one containing stain (polychrome methylene blue) that these figures were seen. The blue coloration of the spindle is exaggerated in the drawing ; in the living cell it was very faint.

5 15.11  
C 88

# RESEARCHES INTO INDUCED CELL-REPRO- DUCTION IN AMŒBÆ

BY

JOHN WESTRAY CROPPER, M.B., M.Sc.  
LIVERPOOL, M.R.C.S. ENG., L.R.C.P. LOND.

AND

AUBREY HOWARD DREW

WITH ILLUSTRATIONS

THE JOHN HOWARD  
McFADDEN RESEARCHES

VOL. IV

LONDON  
JOHN MURRAY, ALBEMARLE STREET, W.,  
APRIL 1914

ALL RIGHTS RESERVED

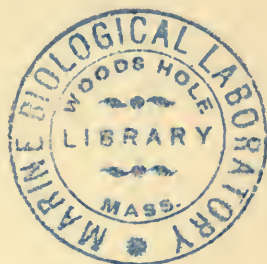

## PREFACE

THE experiments described in the following papers were begun in January 1913, and they form part of the general researches of the John Howard McFadden Research Fund into the causation of cancer and other forms of cell-proliferation. These researches have already been described in detail in the preceding volumes. They include a working hypothesis that normal cell-reproduction and benign tumours are caused by certain chemical agents, called auxetics, such as tyrosin, creatin, etc.; and that cancerous tumours are caused by a mixture of auxetics with another group of substances, called kinetics or augmentors, such as choline and cadaverine. Auxetics are produced in the body by cell-death as the result of injury; kinetics are decomposition products produced by the action of bacteria and other organisms. The former volumes contain many experiments made in the endeavour to prove this hypothesis, but those experiments were mostly made with human and other animal cells; in the present volume, however, we have not touched on the immediate cancer

problem, but have dealt almost entirely with amœbæ, our object being to determine if possible the way in which auxetics and kinetics are capable of exciting reproduction in these cells, and how they are produced in nature so as to have this action. The amœba was selected for this purpose as a type of individual cell which can readily be cultivated and in which the common vital phenomena of movement, nutrition, and particularly reproduction can be watched with comparative ease, and the influence of chemical agents on these processes can be tested with a certain amount of precision. But a more important point for our purpose is the fact that amœbæ depend for their existence under natural conditions on the growth of accompanying bacteria, and, as auxetics and kinetics are prominent among the products of bacterial activity, the effects of these substances can be studied as they are actually being produced. As side issues in the investigation, we have examined the influence of environment on morphology and life-history from a chemical point of view, as the factors concerned in the production of cell variation are still so little understood. As a subject for experimentation, however, when compared with tissue and other cells, amœbæ have one disadvantage in that they periodically exhibit the remarkable phenomena of encystment and excystation. We had previously been able to induce divisions in the resting spores of *Polytoma* (*P. granulosa*) by various combinations of auxetics and



kinetics (*e.g.* suprarenal extract, cadaverine, etc.), and, from the fact that the induced division forms had been seen to leave the spores as free-swimming flagellates, the possibility was suggested that encystment and excystation might depend on some chemical action brought about or assisted by the auxetics and kinetics present. For these reasons we have therefore investigated the chemical factors which play a part in one of the most prominent features in the life of an amoeba, namely, the formation of resting or protective cysts. The volume is divided for convenience into four parts; in the first, the characters of the amoeba under natural and artificial conditions are described and compared, special methods of examination are shown, and the action of auxetics and kinetics is considered. In the second part, a detailed account of the phenomena of encystment and excystation is given. The third chapter deals with the preparation of pure mixed cultures; and, in the fourth, a description of a parasite of amoebæ is given. We desire to express our grateful appreciation to the governing body of the Lister Institute of Preventive Medicine, which has for the time being placed some laboratories at our disposal. Most of the illustrations were kindly drawn for us by Miss M. Rhodes.

J. W. CROPPER.

A. H. DREW

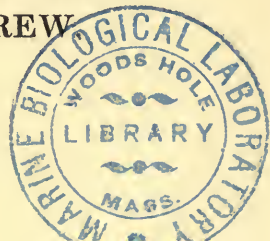





## PREVIOUS PUBLICATIONS

### ON THE WORK OF THE JOHN HOWARD McFADDEN RESEARCHES

ON THE DETERMINATION OF A COEFFICIENT BY WHICH THE RATE OF DIFFUSION OF STAIN AND OTHER SUBSTANCES INTO LIVING CELLS CAN BE MEASURED. *The Proceedings of the Royal Society*, B, Vol. 81, April 1909, contains the preliminary description of the jelly method of staining living cells, together with the principles of estimating the coefficient of diffusion, by which the subsequent researches were made.

INDUCED CELL-REPRODUCTION AND CANCER. London, John Murray; and Philadelphia, P. Blakeston's Sons & Co., December 1910. This volume gives, in its first part, a full description of the jelly method, with many photographs and examples of its application; in the second part it describes the action of chemical agents on the stained living cells, and introduces the study of the action of auxetics in causing the cell-division of human white blood cells. The third part of the volume contains the details of a working hypothesis regarding the cause of cancer and other tumours based on the action of auxetics.

RESEARCHES INTO INDUCED CELL-REPRODUCTION AND CANCER, Vol. I. London, John Murray; and Philadelphia, P. Blakeston's Sons & Co., September 1911. Gives the chemical isolation of auxetics and a complete list of them; a method of fixing cells after they have been stained alive with the jelly method; a preliminary note on the researches made into the question of pitch cancer; and some work done on granular red-blood corpuscles.

RESEARCHES INTO INDUCED CELL-REPRODUCTION AND CANCER, Vol. II. London, John Murray; and Philadelphia, P. Blakeston's Sons & Co., April 1912. A continuation of the researches with auxetics by inoculation into animals with the artificial production of benign tumours. There is a discussion about the division-figures induced by auxetics, and a description of the action of the latter on certain ova. The question of pitch cancer is further described, with a review of the first official inquiry on the subject. The first work with the jellies on protozoa is mentioned with the discovery of *Lymphocytosoon cobayæ*.

RESEARCHES INTO INDUCED CELL-REPRODUCTION AND CANCER, Vol. III. London, John Murray; and Philadelphia, P. Blakeston's Sons & Co., April 1913. This volume brings the researches on pitch cancer up to the date of the second official inquiry. The demonstration of the action of auxetics on leucocytes by precise methods is described, and the production of adenomata in goat's breasts mentioned. There is a suggestion for the treatment of wounds by auxetics. The second part of the volume deals with the continuation of researches into protozoology by the jelly method, and a demonstration of what appear to be intracellular parasites in syphilis, scarlet fever, and measles.



# CONTENTS

## I

	PAGE
THE INFLUENCE OF ENVIRONMENT AND THE ACTION OF AUXETICS AND KIN- ETICS ON AMŒBA . . . . .	15

## II

EXPERIMENTS ON THE CAUSES OF ENCYST- MENT AND EXCYSTATION OF AMŒBA . . . . .	46
---	----

## III

THE PREPARATION OF "PURE MIXED CULTURES" OF AMŒBA . . . . .	77
--	----

## IV

A PARASITE OF AMŒBA . . . . .	102
BIBLIOGRAPHY . . . . .	107
INDEX . . . . .	111



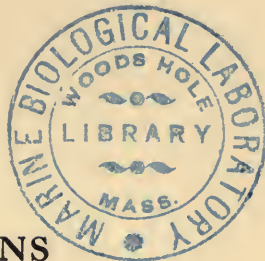

## LIST OF ILLUSTRATIONS

	SUCCESSIVE STAGES OF NUCLEAR DIVISION SEEN IN ONE LIVING AMEBÆ . . . . .	<i>Frontispiece</i>
FIG.		FACING PAGE
	1. SUCCESSIVE CHANGES IN SHAPE OF AMEBÆ EXAMINED IN TAP WATER ON A "LIVE SLIDE" . . . . .	18
PLATE		
	I. SPECIAL METHOD DEvised FOR THE CONTINUOUS OBSERVATION OF AMEBÆ . . . . .	20
	II. LIVE SLIDE FOR THE PROLONGED EXAMINATION OF AMEBÆ IN SOLUTIONS OF CONSTANT STRENGTH . . . . .	20
	III. CULTIVATION OF AMEBÆ BY THE "MOIST AIR CHAMBER" METHOD . . . . .	22
FIG.		
	2. ISOLATION OF A SINGLE CYST OR A GROUP OF CYSTS . . . . .	22
	3. PHOTOMICROGRAPH OF GROUPS OF CYSTS (LOW POWER) . . . . .	22
	4. APPARATUS FOR TESTING THE ACTION OF GASES ON AMEBÆ OR AMEBÆ CYSTS . . . . .	22
	5. AMEBÆ EXAMINED BY THE JELLY METHOD . . . . .	22
	6. STAGES OF NUCLEAR DIVISION SEEN BY THE JELLY METHOD . . . . .	24
	7. CHANGES IN THE NUCLEUS OF A LIVING AMEBÆ OB- SERVED BY THE JELLY METHOD . . . . .	24
	8. COARSELY GRANULAR VARIETY OF THE AMEBÆ . . . . .	24
PLATE		
	IV. STAGES OF NUCLEAR DIVISION OF AMEBÆ SHOWN BY THE JELLY METHOD OF STAINING . . . . .	26
	V. <i>In-vitro</i> STAINING OF AMEBÆ BY THE JELLY METHOD . . . . .	26
	VI. AMEBÆ CYSTS STAINED BY THE JELLY METHOD . . . . .	26
	VII. SOME WELL-KNOWN TYPES OF AMEBÆ . . . . .	28
FIG.		
	9. AN ACCUMULATION OF SPHERICAL GRANULES IN AMEBÆ WHICH OFTEN PRECEDES ENCYSTMENT . . . . .	32
	10. APPEARANCE ASSUMED BY AMEBÆ WHEN DYING . . . . .	32
	11. BINARY FISSION OF MULTINUCLEATE FORMS OF THE AMEBÆ . . . . .	32

FIG.	FACING PAGE
12. BUDDING IN AMCEBA . . . . .	32
13. MINUTE AMCEBULÆ AND A VERY SMALL AMCEBA CYST	32
PLATE	
VIII. BINARY FISSION OF AMCEBA . . . . .	34
IX. CONJUGATION OF AMCEBÆ . . . . .	34
FIG.	
14 and 15. LONG, SLENDER FORMS OF THE AMCEBA . . . . .	38
16. PHOTOMICROGRAPH OF A LONG, SLENDER FORM OF THE AMCEBA . . . . .	38
17. LARGE MULTINUCLEATE FORM OF THE AMCEBA ON A TYROSIN MEDIUM . . . . .	40
18. INDUCED DIVISIONS IN <i>Polytoma granulosa</i> . . . . .	40
19. PHOTOMICROGRAPH OF AMCEBA CYSTS . . . . .	40
20. RADIOSE (TYPE 1) FORM OF THE AMCEBA . . . . .	44
21. RADIOSE (TYPE 2) FORMS OF THE AMCEBA . . . . .	44
22. EFFECTS OF STARVATION ON AMCEBA . . . . .	52
23. QUIESCENT FORMS OF THE AMCEBA . . . . .	52
24. AMCEBA CYSTS FREE FROM LIVING BACTERIA . . . . .	52
25. AN AMCEBA-LIKE ORGANISM WHICH INFECTED SOME OF THE CULTURES . . . . .	52
26. PHOTOMICROGRAPH OF AMCEBA IN "PURE MIXED CUL- TURE" WITH <i>Bacillus fluorescens non-liquefaciens</i> . . . . .	84
27. PHOTOMICROGRAPH OF AMCEBA CYSTS ADHERING TO A COLONY OF BACTERIA . . . . .	84
28. PHOTOMICROGRAPH OF A PURE CULTURE OF <i>Bacillus flavo coriaceus</i> . . . . .	96
29. PHOTOMICROGRAPH OF A PURE CULTURE OF <i>Bacillus fluorescens liquefaciens</i> . . . . .	96
30. PHOTOMICROGRAPH OF <i>Bacillus proteus vulgaris</i> . . . . .	102
31. A PARASITE OF THE AMCEBA . . . . .	102
32. PHOTOMICROGRAPH OF AMCEBÆ INFECTED WITH A PARASITE . . . . .	104
33. PHOTOMICROGRAPH OF A PURE CULTURE OF THE AMCEBA PARASITE . . . . .	104



# RESEARCHES INTO INDUCED CELL-REPRODUCTION IN AMŒBÆ

## I

### THE INFLUENCE OF ENVIRONMENT AND THE ACTION OF AUXETICS AND KINETICS ON AMŒBA

*Introduction.*—For the benefit of those who are not acquainted with the nature of experiments on individual cells, we think it advisable to give a short general description of an amœba, so that the kind of cell on which the researches have been carried out will be better understood. An amœba is a unicellular organism belonging to the group of those low forms of animal life which are known as protozoa. It has a widespread distribution and may be found in a variety of situations such as water, damp earth, etc., and in the bodies (usually the intestinal tract) of many animals and of man. In the latter situations certain varieties of amœba may produce disease, but the large majority of the known species appear to be harmless. From the fact that distinct differences in structure and life-history can be made out between many of the individual amœbæ, it has been possible to establish

a genus for the whole group, and to distinguish its members by subdivision into species.

Amœbæ are of minute size, only the larger varieties being visible to the naked eye; and they are suitable objects for examination with the microscope, as they can be watched continuously while discharging the functions which are characteristic of a living cell. The body of each individual amœba consists of a mass of protoplasm which in some species is regarded as almost naked and in others is undoubtedly invested by a distinct cuticle, the density of which may limit the movements of the cell very considerably. Imbedded in the cytoplasm is the nuclear matter or chromatin, which may exhibit an extraordinary diversity of distribution in different circumstances, ranging from a solid-looking mass (nucleus) to a large number of almost imperceptible granules (chromidia). Under natural conditions amœbæ will only live in the presence of living bacteria, and this association has often been regarded as an example of "symbiosis," but quite erroneously, as there is no mutual benefit. The bacteria are utilised as food by the amœba, and it is generally understood that the nutrition of this cell is dependent on the ingestion of solid particles whose chemical composition is of a protein nature, as amœbæ appear to be unable to build up their protoplasm from simpler substances. This characteristic of the amœba is of importance to these researches, as it will be shown later that the influence of food can be discriminated from the action of auxetics and kinetics in exciting cell-division.

It is essential for the continued existence of

living cells that reproduction shall take place at some time or other, and in the amœba this phenomenon presents a large variety of methods which in some instances appear to depend on the presence of particular chemical agents in the environment.

Lastly, amœbæ are able to protect themselves from harmful conditions of their surroundings by forming a resistant envelope round their delicate contents, the process being termed "encystment," and the bodies so formed being called "cysts."

Under the influence of certain altered conditions the amœbæ are enabled to escape from the cysts, and this phenomenon is described as "excystation."

*Type of Amœba employed.*—The particular amœba on which the following experiments have been carried out was found growing in a sodium citrate and sodium chloride solution (3 per cent. and 1 per cent. respectively) which had been left lying exposed to the air of the laboratory for some months. At the outset it was found difficult to classify it with any of the better-known species of amœba; at any rate it was difficult to do so upon the characters of its body-form and movements. Its presence also, and active multiplication in a mixture of such a high degree of saline concentration suggested the possibility that, even if it was not a new species, a modification of type had in some way taken place. As subsequent results have shown that the appearance of amœbæ, on which their classification is to some extent based, is subject to the environment to which they are exposed, a differentiation into species based on morphology alone is of little real importance. In our opinion it is only by gross differences in habits, life-cycle, and



type of nuclear division that the probability of specific distinction can be inferred. The more advanced the knowledge of these organisms becomes, the more difficult it is to determine the characters on which subdivision into species should be made, and in all probability the species gradually merge into each other. The amœba under consideration exhibits minor differences in several respects from types already described in the literature of the subject, and, in order to distinguish it, the name *Amœba ostrea* is provisionally suggested for this variety, from the fact that its common form when in a resting condition resembles that of an oyster (fig. 1). In general appearance and common mode of nuclear division, which is a form of promitosis, this amœba most nearly resembles a new species discovered by Swellengrebel and named by him *Amœba salteti*. It appears to be a fresh-water species belonging to the genus *Vahlkampfia*, and is non-pathogenic to guinea-pigs, dogs, and man.

*Special Methods of Examination.*—A description is given in detail of the technique employed in the routine examination of amœbæ and their cysts, under different conditions of environment, in the hope that it may be of use to those who wish to take up the jelly method in the study of other protozoa. At the outset we discarded the employment of slope cultures in test-tubes as we were not always able to recognise and to recover amœbæ from them under the artificial conditions to which they were often subjected. We found small Petri dishes (two inches in diameter) preferable to the larger ones, as they are more easily handled and can



I.



II.



III.



IV.



V.



VI.

FIG. 1, I.-VI.—Successive changes in shape of Amoeba (*A. ostrea*, n. sp.). Examined in tap water on a "live slide."



be applied to a microscope fitted with a mechanical stage. The methods used for different purposes may be classified as follows :

**METHOD A.—EXAMINATION IN A SOLUTION OF CONSTANT STRENGTH**

It was not so easy as at first expected to keep amœbæ or their cysts in a solution of constant strength under conditions suitable for continuous observation under the microscope, because the layer of liquid plus the thickness of the cover-glass must not be so great as to prevent the use of high-power objectives. The cover-glass must not rest on the preparations, as amœbæ are thereby gradually killed and cysts will not excyst under the pressure. Again, the stagnation which occurs in the usual forms of live cells on microscope slides is harmful to amœbæ, as they appear to require more oxygen than they can then obtain. These difficulties were obviated in two different ways, viz. :

*Method A, 1.*—A sheet of thin glass about three inches long by two inches wide is placed on the microscope stage, and over this is spread a piece of very thin fine-meshed muslin (chiffon). On moistening this it will spread out quite flat. Amœbæ or amœba-cysts are dropped on to the cloth, and can be seen with the microscope lying between the meshes on the surface of the glass plate (Pl. I., A). One end of the muslin falls into a bottle containing water or the solution to be tested, in the latter case evaporation being prevented by covering the whole apparatus over with a shallow dish. It was noticed that, if a cover-glass be placed over the cysts,



excystation will not take place unless there is a constant slow stream of fluid beneath it. For example, if the muslin is made to dip into the solution all round, no excystation occurs, since there is a condition of stagnation, and a deficiency of bacterial growth under the cover slip; whereas cysts placed on the slide external to the cover-glass excyst in about twenty-four to forty-eight hours (Pl. I., B). If the circulation beneath the cover-slip is made more rapid by tilting the slide, no excystation again takes place, as the products of bacterial action which effect this are washed away. A thin film of jelly can be spread on the glass slide, and this in its turn covered with the muslin, and, by this method, excystation can be observed on a jelly surface.

*Method A, 2.*—The principle of the above method was adopted and an improvement made by using thicker cloth (calico) which had a circular hole cut in the centre slightly larger than the diameter of the cover-slip—the latter being prevented from pressing on the amœbæ by interposition of strips of paper. This apparatus has been very useful for the prolonged examination of amœbæ exposed to the action of auxetics and kinetics, as it enables continuous observations to be carried out indefinitely with very little trouble, and is more satisfactory than many of those which have been employed. A short description of such a “live slide” may be given here:

*Live Slide* (Pl. II., A and B).—A plate of thin glass about three inches long and two inches wide has a narrow glass arm cemented to it along the short end, forming a projection upon which a small

B

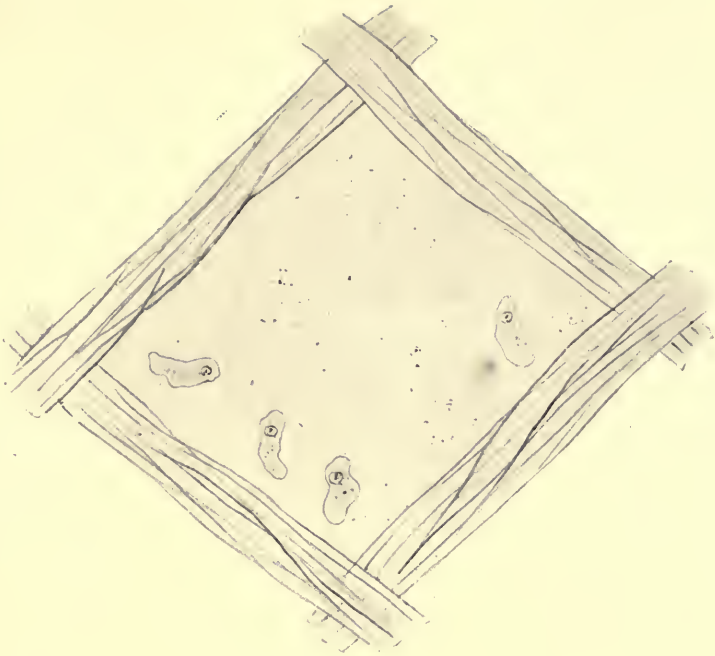

Amoebae which have escaped from the cysts.

A

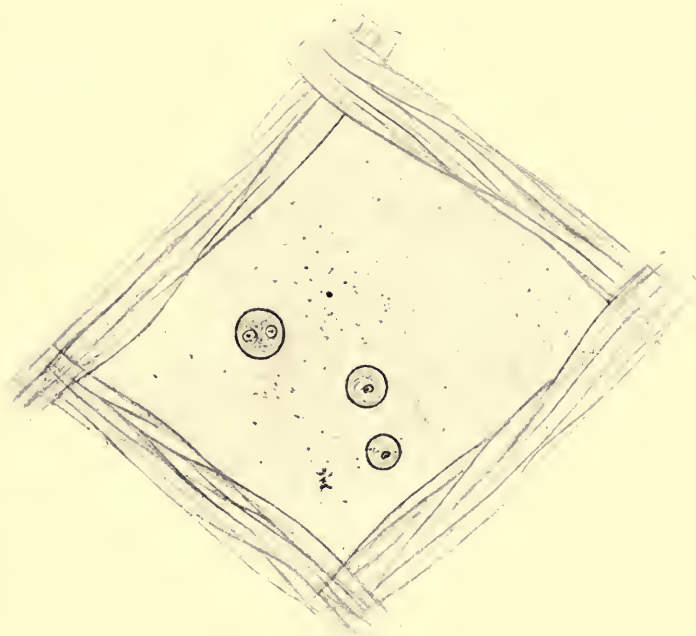

Amoeba cysts lying between the meshes of a piece of thin muslin spread on a glass plate. They are, under conditions which are suitable for the continuous observation of amoebae with high powers of the microscope.



A

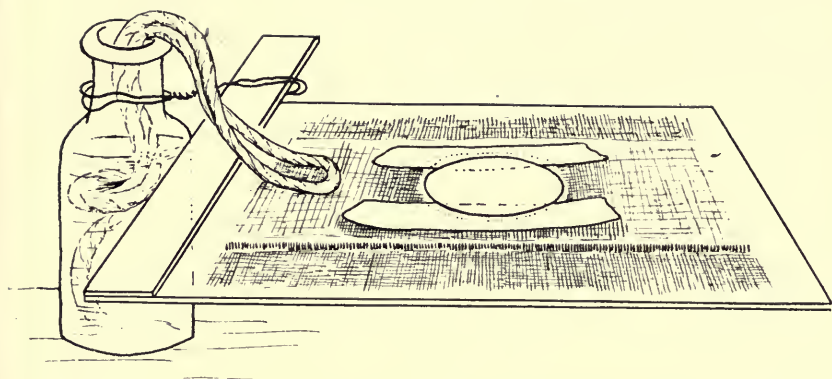

Live slide for the continuous observation of amoebae in solutions of constant strength. The amoebae are placed on the cover-slip, which is prevented from pressing on the glass plate underneath by the interposition of two strips of thin paper. The solution slowly circulates from the bottle along the wick to a piece of linen on the glass plate and prevents the preparation from drying up.

B

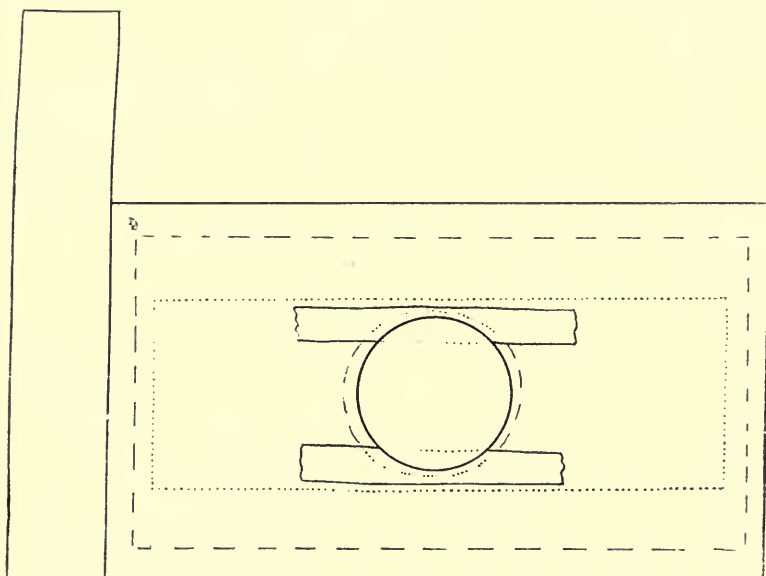

Upper surface of the above "live slide."



bottle can be hung by means of a piece of wire. The plate is covered over with a sheet of fine calico having a circular hole in the centre just large enough to permit of a cover-glass resting on the plate with its edges almost touching the cloth all round. Two narrow strips of cigarette paper are placed on opposite sides of the aperture under the cover-glass to prevent this from actually pressing on the slide. This support is absolutely necessary when examining amœbæ, but can be dispensed with in the case of smaller bodies such as flagellates, etc. Water or the solution to be employed is placed in the bottle, and is slowly conveyed by capillarity along a piece of lampwick to the cloth, which is in this way kept continually moist. The amœbæ (free forms or cysts) are put into a drop of the solution on the cover-slip, which is then inverted and allowed to rest on the slide in the way described. This apparatus has been in constant use for weeks without drying up of the cloth or of the solution under the cover-glass, all that is necessary being to put a little fresh solution in the bottle every few days. Either free amœbæ or cysts may be examined in this way, and when required, a jelly may be interposed between the slide and the cover-glass as described above.

#### METHOD B.—EXAMINATION ON A JELLY SURFACE

This is an adaptation of the principle employed in slope cultures in test-tubes with water of condensation, but has the advantages that the amœbæ can be examined at any time without interference and there is no danger of drying up. This “moist-



air-chamber method" is as follows: A jelly film is allowed to set in the bottom of a small two-inch Petri dish. Cysts are then placed on one or more spots on the surface and the dish is inverted over water in a larger vessel (Pl. III., A). Thus there is a moist air space between the water and the jelly, and evaporation is prevented. By this means a more abundant growth is obtained than if a Petri dish in the ordinary upright position is used, and it is the best way of maintaining a constant stock of the culture. By the continuous supply of moisture and air combined with emigration of the amœbæ from the original site of the inoculation, growth continues almost indefinitely until the whole surface of the jelly is nearly a solid mass of cysts. Again, the amœbæ which have wandered from the central spot tend to run together into clusters (fig. 2), and by this means groups of cysts, which may contain any number up to a hundred or so, can be picked off almost bacteria free in a capillary tube and employed in the preparation of pure cultures (fig. 3).

A modification of this method, which has been found useful for various purposes, and which can be kept sterile for some time, is to use a jelly film on a microscope slide which is then inverted, resting on corks, over water in a large Petri dish (Pl. III., B). A cover-slip may then be employed, and does not press on the amœbæ. For continuous observations extending over a few days, a live cell made of molten paraffin wax has occasionally been used in the following way: A thin film of jelly on a cover-glass is smeared with cysts and inverted quickly over a layer of soft wax (which has a hole in it), a



A

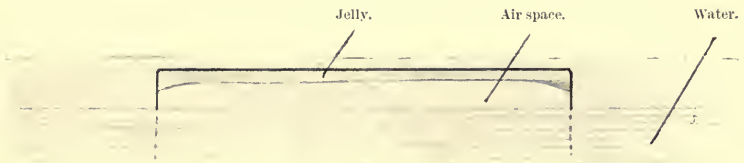

Cultivation of amœbæ by the "moist-air-chamber" method. The most rapid growth of amœbæ is obtained on a jelly surface which is over (not in contact with) water. The diagram shows a culture in a small Petri dish over water in a larger dish. Auxetics and augmentors can be added to the jelly and their action on the amœbæ observed

B

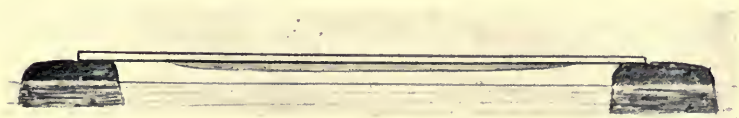

A modification of the above method. The jelly film is on a microscope slide, which is inverted (resting on corks) over the water.



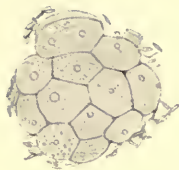

FIG. 2.—A single amœba cyst and a cluster of cysts; suitable for preparation of "pure mixed cultures."



FIG. 3.—Photomicrograph of groups of cysts.

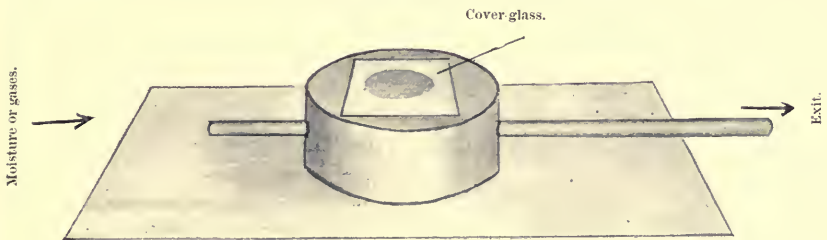

FIG. 4.—Apparatus for the continuous observation of amœbæ by the jelly method under varied conditions of environment.

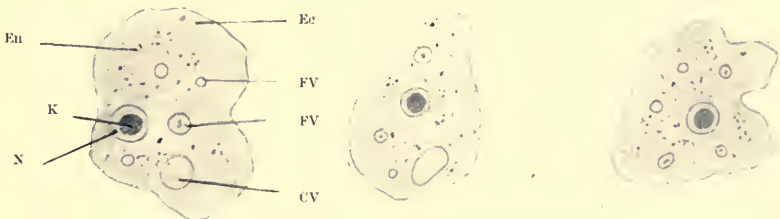

FIG. 5.—Successive form changes in an amœbæ examined by the jelly method. N, nucleus; K, karyosome; CV, contractile vacuole; FV, food vacuoles; Ec, ectoplasm; En, endoplasm.



few drops of water being placed at the bottom of the hole, and the complete cell then sealed with molten wax and vaseline. In addition to these methods, an apparatus was constructed for testing the effect of gases (fig. 4). Lastly, for the continuous examination of amœbæ or amœba-cysts by the jelly method under sterile conditions and with high powers of the microscope, a Petri dish has been made of brass with circular holes cut in the top and bottom—thin cover-slips being then fixed over these with Canada balsam. The inner surface of each half of the dish is provided with a flange, so that jelly can be poured into one half and water into the other. The whole dish is applied to the microscope stage, and, if the jelly film is made very thin, amœbæ can be kept under observation for days in the absence of any bacterial growth.

*Advantages of the Jelly Method.*—When an amœba is examined in a solution it is free to protrude its pseudopodia in any direction, and the consequent changes in appearance are so rapid and varied as to interfere with an accurate examination of the influence of chemical and physical agencies. On the other hand, on the surface of a jelly movement is limited to one plane and the amœba is more spread out, rendering modifications obvious which might otherwise escape notice (fig. 5). For example, the processes of encystment and excystation can be more closely watched and the rate of diffusion of stain and various chemical substances into the living cell can be observed, and controlled by altering the reaction and temperature of the medium, etc. It is essential in carrying out any routine work on the influence of external factors to

select some method for permanent use, and the jelly method gives the most satisfactory results. One special advantage of this method is that the nucleus is always in view, and changes can be seen taking place in it in the living unstained cell (fig. 6).

*Choice of Media for Cultures.*—For ordinary stock-cultures a 2-per-cent. agar jelly made with distilled water only is used; the addition of salts is of no advantage, as there is an ample growth of bacteria to supply the amœbæ with food without them. Nutrient media are quite unsuitable under ordinary circumstances, as the over-abundant bacterial growth which they bring about is deleterious to amœbæ; they may, however, be employed with certain pure strains of slow-growing bacteria, or of those which do not produce poisonous substances which are injurious to the amœbæ. We have not found agar strained through egg-white an advantage over that filtered through paper or cotton-wool, although Wherry is inclined to think that the ovo-mucoid extracted by the first-named method is favourable to the growth of amœbæ. Gelatin media are no use for impure cultures, but with non-liquefying bacteria they serve as a useful test of purity. At last, when we were able to cultivate the amœbæ in the absence of living bacteria, we employed a jelly consisting of 2-per-cent. agar two parts and 12-per-cent. gelatin one part, because in addition to this being very transparent and sterilisable by boiling, it showed any bacterial contamination, for the bacteria caused the gelatin to liquefy.

*In-vitro Staining by the Jelly Method.*—This consists in placing the amœbæ or their cysts on a

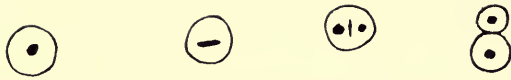

FIG 6.—Jelly method. Some stages of nuclear division in the unstained living amoeba. The nucleus only is shown.

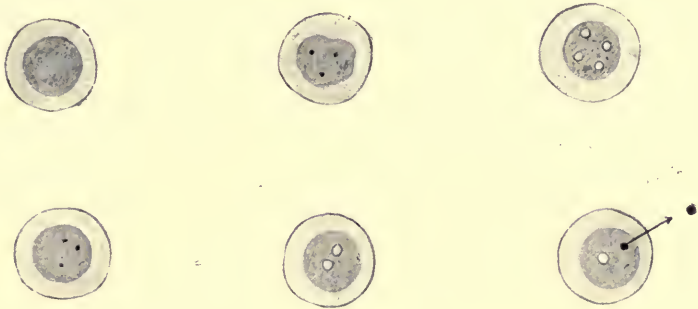

FIG. 7.—Jelly method. Successive changes in appearance of the nucleus of an amoeba during a period of ten minutes. Finally a spherical granule was discharged into the endoplasm.



FIG. 8.—Coarsely granular variety of the amoeba.





jelly film which contains the stain in solution. To 5 cc. of 2-per-cent. agar jelly (with or without the addition of salts) stain and alkali to the required amount are added, and the total bulk is made up to 10 cc. with distilled water. This is melted and poured on a microscope slide, where it sets when cold. A platinum loopful of amœbæ is smeared on a cover-glass, which is then inverted and allowed to fall on the jelly film, when the stain diffuses into the cell while it is still alive. The coefficient of diffusion of this amœba is very low, viz. with 0·2 cc. of 5-per-cent. sodium bicarbonate (alkali) and 0·1 cc. of Unna's polychrome methylene blue (stain) the nucleus stains a pale purple colour in ten minutes at 20° C. The coefficient of diffusion (cf) is therefore:

$$Cf = \begin{matrix} \text{Stain} \\ (1\ s) \end{matrix} + \begin{matrix} \text{Alkali} \\ 4\ a \end{matrix} + \begin{matrix} \text{Heat} \\ 3\ h \end{matrix} + \begin{matrix} \text{Time} \\ 1\ t \end{matrix} = 9$$

Stages of nuclear division are shown by the jelly method with ease (Pl. IV.), and the degree of staining can be regulated by means of the alkali while the specimen is under observation. Staining of the granules does not cause death of the amœba, and it may even move for some minutes after the nucleus stains, but it then rapidly dies and becomes spherical (Pl. V.). Amœbæ may be fixed before or after staining by means of formalin, absolute alcohol, or Schaudinn's fluid. In the preparation of fixed films from test-tube cultures, it is unsatisfactory simply to make cover-slip smears which are then immediately fixed and stained, because the amœbæ have shrunk from the shock of the removal and their contents are massed together.

If, however, the smear is first dropped on to a film of 2-per-cent. agar jelly, and allowed to remain there for about an hour, the cover-glass can then be lifted off quickly and dropped on to a second jelly which contains the fixative. It can then be removed at leisure and stained by the jelly method, the cover-glass being removed from the jelly and mounted in balsam when the required degree of staining is obtained. To stain the cysts (Pl. VI.) we found the use of a highly diffusible alkali (*e.g.* di-ethylamine) combined with a minimum quantity of stain (Azur II.) most effective. The drawback in staining bodies such as cysts, which have thick envelopes, is that the latter become highly coloured before the contents, which are therefore obscured. With the jelly method, using excess of alkali, the stain is forced in rapidly before the dilute solution of stain has time to saturate the wall. The main features of the stained cysts are as follows: The ectocyst selects the red portion of the polychrome dye and stains only faintly; the cyst contents, including the nucleus, take on a blue or purple colour according to the amount of alkali present in the jelly. The most striking bodies are the "corpuscles chromatoides," which appear at first comma-shaped but later become solid-looking spheres (*vide* Pl. VI. 6-8). The cysts are acid-fast and are not decolourised even by pure hydrochloric acid. With an excess of stain the endocyst becomes a deep blue colour and its contents cannot be recognised.

It is better to select young cysts for staining purposes, as old ones are so resistant. The nucleus is usually single and concentric, but two of them

Stages of nuclear division of amoeba shown by the jelly method of *in-vitro* staining with Unna's polychrome methylene blue.

1, 2. The so-called "resting" nucleus.

3-8. Some stages in the division of the nucleus.

9. An equatorial plate can occasionally be distinguished.

10, 11. The nucleus breaking up into smaller portions.

12. A dividing nucleus which has been liberated from the amoeba by treatment with alkali.



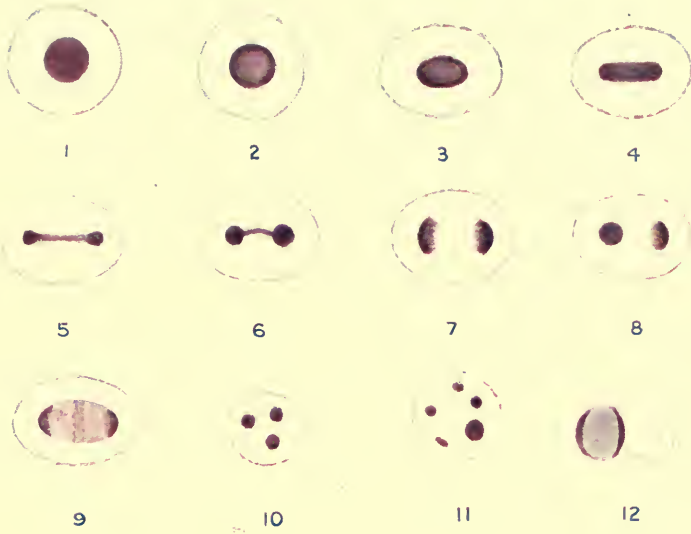

1. The first of these is the fact that the  
2. second is the fact that the  
3. third is the fact that the  
4. fourth is the fact that the  
5. fifth is the fact that the  
6. sixth is the fact that the  
7. seventh is the fact that the  
8. eighth is the fact that the  
9. ninth is the fact that the  
10. tenth is the fact that the



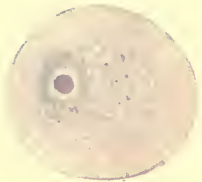

1

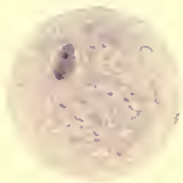

2

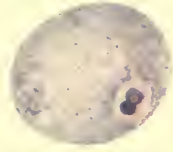

3

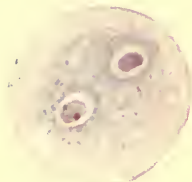

4

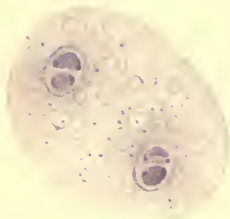

5

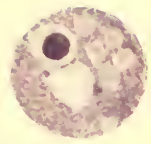

6

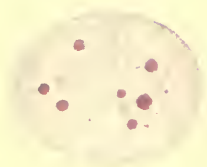

7



8



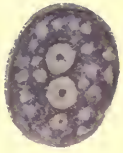

4



3



1



6

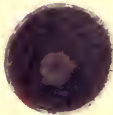

5

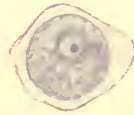

2

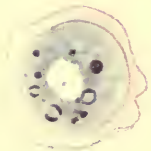

7

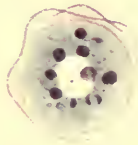

8

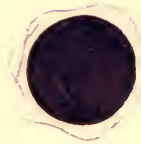

9

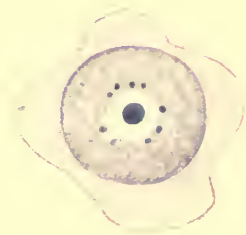

10

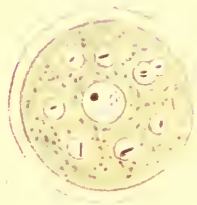

11



are fairly common, and as many as four may be present.

*Characters of the Amœba.*—The average diameter of the body of the organism is about 20  $\mu$ . It consists of a finely granular endoplasm surrounded by a very narrow layer of clear ectoplasm which is increased in amount in one direction, presenting an appearance of the granular portion having shrunk away from one side. The endoplasm contains the usual contractile vacuole, food vacuoles, ingested bacteria, moulds, and débris of all kinds, and a vesicular nucleus showing a distinct karyosome. The movements are fairly active, the pseudopodia being lobose in type, and progression is by crawling. In comparison with *Amœba proteus* it is less active, much smaller, and imports its food rather than seizes it. It has not, however, the rolling motion of *A. verrucosa* nor the slug-like crawl of a typical limax amœba (Pl. VII.). The nucleus is usually single, sometimes double, and occasionally multiple, the greatest number yet seen in a single cell being six. The size of the amœba is no indication of the number of nuclei, one of the largest observed being mononuclear, and some quite small ones having been seen containing as many as four nuclei. The nucleus occupies a changeable position in the endoplasm, and is subject to considerable alterations in shape owing to the movements in the surrounding protoplasm. A centriole, possibly a centrosome or nucleolus, may often be seen either in the unstained condition or when stained by the jelly method (Pl. V.). In large nuclei small circular spots can be observed alternately light

and dark, suggestive of internal movements (the nucleus being stationary and always in focus), and on one occasion a spherical granule was noticed to leave the nucleus, and was lost to view in the cytoplasm (fig. 7).<sup>1</sup> The nuclei of the cysts are also usually single, but there may be two, three, or even four present. The contractile vacuole is a prominent feature in every cell and completes a pulsation once in about forty seconds when the amœba is in an active, healthy condition. The food vacuoles are of no particular interest; they contain bacteria, etc., in all states of digestion, and may be scanty or so numerous as to occupy almost the whole of the cell. The granules of the endoplasm are usually small, but in some cultures many of the amœbæ contained large ones only (fig. 8). These are distinguishable by their faint staining reaction with polychrome methylene blue from the volutin granules which accumulate in many amœbæ prior to encystment, and which take up an intense blue colour with the dye. The amœbæ encyst at intervals to protect themselves from so-called adverse conditions of the surroundings.

During cultivation through several generations it is interesting to observe that the characters of the amœba have changed slightly from those which were present in the original growth in the citrate solution. The pseudopodia were then markedly lobose; when the cells moved, the ectoplasm, followed by a small portion of the granular part, sluggishly flowed round the main body of the organism, another portion of the periphery subsequently resuming and continuing

<sup>1</sup> Intranuclear changes in the so-called resting nucleus have also been observed by Léger and Duboscq, and others in various organisms.



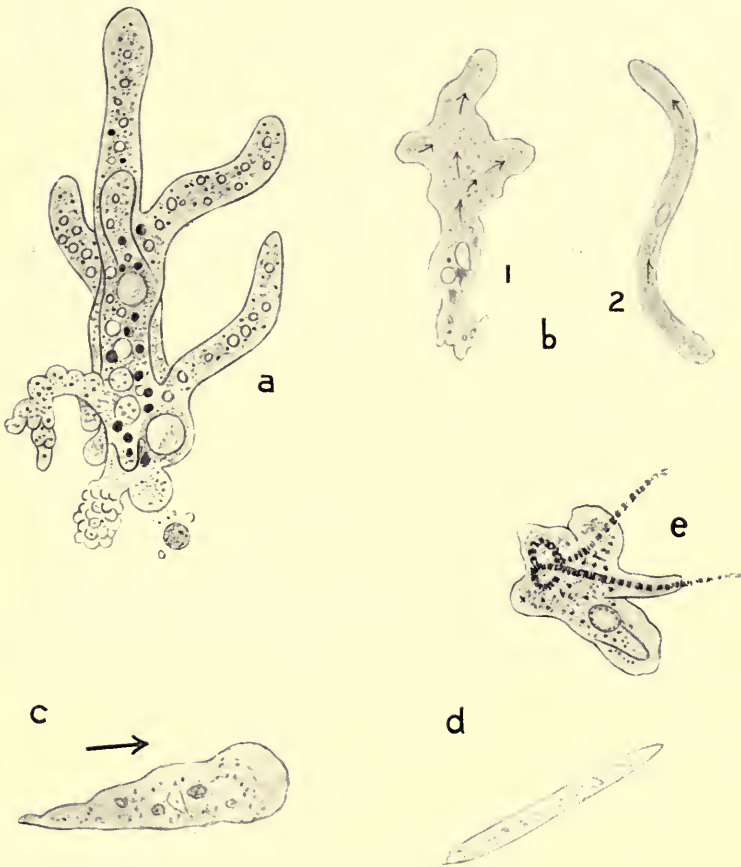

Some of the common types of Amœba

- a. *A. proteus* (after Leidy)  $\times 200$ .  
 b. Wanderform von *A. proteus* (after Grüber).  
 1. Gewöhnliche. 2. Wurmformige.  
 c. *A. limax*.  
 d. *A. gracilis* (after Penard).  
 e. *A. verrucosa* (after Rhumbler).



this movement. Actual projections from the surface were only occasional and never marked, and progression was very slow. The amœba has also become smaller on the average, a similar diminution in size being found to take place in a large pond amœba after cultivation for some time in tap water. Possibly the comparative absence of salts has something to do with this modification, as Wherry noticed a similar influence on the species of amœba with which he worked. The peculiar type of movement first observed was found to alter after cultivation on salt-free agar media, and has not been regained, although, on jellies containing a high percentage of sodium citrate, there is a distinct increase in size of the whole cell.<sup>1</sup>

*Movement.*—As far as we now know, the character of the movements of an individual amœba is determined both by the chemical and the physical condition of its environment. The same amœba exhibits different types of motion according to the circumstances under which it is examined. In a hanging-drop preparation, motion is unrestrained and the body turns over and over, rapidly exposing different aspects to the view of the observer, and progression takes place partly by means of this rotation. Resting on a smooth surface (such as glass), progression becomes more of a crawling character. On the surface of a firm jelly the movement is slower, the pseudopodia are

<sup>1</sup> Minchin in "An Introduction to the Study of the Protozoa, 1912," p. 198, refers to the effect of environment, viz.: "These experiments . . . raise the suspicion that many species of marine Protozoa may be only different forms, due to change of medium, of fresh-water species, or *vice versa*."

blunter in form, and the whole cell travels backwards and forwards in any direction. On a soft jelly the rapidity of movement is still further diminished, and consists in the main of a bulging out of one side of the body, the portion left behind flowing into this protrusion. These characters apply to the adult amœba. Young forms are much more active, while conversely, under unsuitable conditions of cultivation as regards quantity and quality of bacterial growth, movements become slower and finally cease. A violent disturbance of the medium causes the body of the amœba to shrink into a more or less spherical shape from which it takes a few minutes to recover. Short, thin pseudopodia are then protruded, and the body gradually resumes its original shape. Movement is slower after ten minutes' exposure at 37° C. than at the room temperature of 20° C. Subsequent reference will be made to the production of a long, thin, rigid type of amœba, and of a radiose type by changes in the chemical composition of the medium.

*Absorption and digestion of food.*—These can be watched with accuracy by the jelly method. Amœbæ have been seen to ingest bacteria and their spores, moulds, flagellates, red blood corpuscles, and even cysts and young ones of their own species. Motile bacteria approaching an amœba as a rule suddenly turn and reverse their direction, but occasionally one adheres to the amœba and turns so as to lie alongside it; its movement then rapidly ceases, and it may or may not be absorbed. Motile bacteria may even pass directly into the amœba without the latter

forming any pseudopodia. After ingestion a vacuole is rapidly formed round the bacterium, and in this the latter enters into violent agitation, spinning round with the greatest rapidity, and eventually coming to rest and assuming a typical shaking Brownian movement, slowly becoming digested and disappearing—the whole process occupying less than five minutes. Large bodies are taken in by the process of “invagination,” and are usually soon expelled, but small yeasts and spores may be retained for some time. Stained by the jelly method, using polychrome methylene blue, the contents of the food vacuoles become an intense blue colour, while with pyronin they turn red in contrast with the yellow endoplasm. Bacteria boiled with litmus until blue, on ingestion turn red. These reactions are suggestive of acidity. Food vacuoles as a rule disappear during encystment, but on the other hand there may be an accumulation of spherical granules in vacuoles within the living amœba (fig. 9) which can be distinguished in the cyst even if unstained (the so-called “corpuscles chromatoides.”) The contractile vacuole is a prominent colourless sac (regarded by some as a rudimentary kidney) which rhythmically contracts and expands, and at intervals bursts and expels its contents to the exterior. It occasionally breaks up into several smaller vacuoles, and these may persist for a time, or may quickly re-form into a single one. During life the contents of the vacuole are invisible, but after death a number of highly refractile granules appear, possibly being a precipitate due to some change in the character of the fluid in the vacuole. The



rate of pulsation is diminished at 37° C. and the vacuole is then larger than at the room temperature. On death of the amœba, the vacuole attains its maximum size and remains motionless. In this condition it may occupy as much as half the bulk of the cell. At the same time, liquefaction of the cytoplasm causes the amœba to become spherical with an apparent increase of the ectoplasm, due to uniform bulging out of the periphery, and granular matter may collect together into masses (fig. 10).

*Life-history.*—A variety of methods of multiplication has been described among the different species of amœbæ, and it is advisable briefly to summarise these, particularly as the type on which we are working appears to constitute a new species.

(A) *Binary Fission.* In the free state, division of the nucleus with or without karyokinesis is followed by division of the amœba into two approximately equal portions. This is the common mode of reproduction which occurs when the amœbæ are under conditions suitable for their continued growth. Rarer occurrences described as taking place in various species are: (B) *Multiple Fission*, the amœbæ breaking up into several smaller ones. (C) *Resolution of the nucleus into chromidia* which form secondary nuclei, these in their turn giving rise to internal buds which become discharged as amœbulæ. (D) *Simple Budding or Gemmation*, a small portion of the body containing nuclear matter being liberated. (E) *Conjugation*, and, under special circumstances, the amœbæ may encyst and various changes take place within the cysts, the nature of which has in many cases served as a basis of classification. Thus (a) *Encystment*



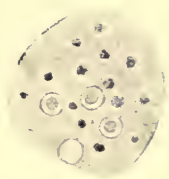

FIG. 9.—Accumulation of spherical granules within vacuoles, previous to encystment.

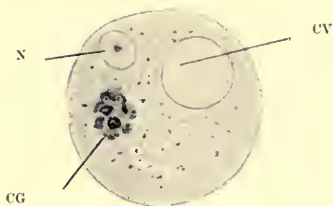

FIG. 10.—Gradual death of amoeba. N, nucleus; CV, contractile vacuole; CG, collection of granular debris.

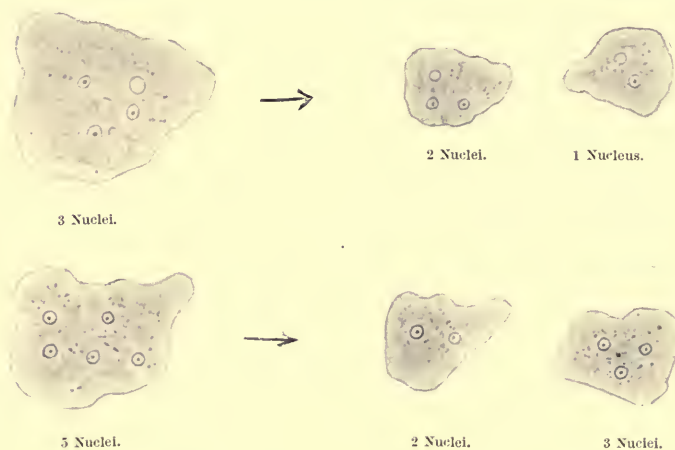

FIG. 11.—Binary fission of multinucleate forms of the amoeba. Note the unequal distribution of the nuclei in the daughter cells.



FIG. 12.—Budding of amoeba observed by the jelly method.

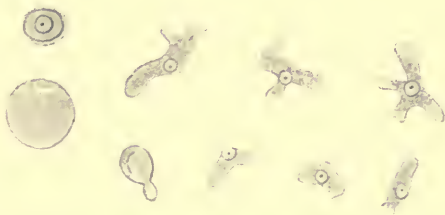

FIG. 13.—Minute amoebulae and a small cyst. Yeast and red blood corpuscle for scale.



followed by autogamy, one zygote leaving the cyst e.g. *A. albida*. This, according to Nägler, is characteristic of the limax type. (b) Encystment with internal changes resulting in the liberation of amœbulæ as described by Popoff. (c) Encystment of multinucleate forms, and the production of secondary nuclei, which eventually develop into amœbulæ after passing through an intermediate flagellate stage. Possibly *A. proteus* multiplies in this way. (d) Flagellate stages have been described in *Paramœba eilhardi*, and by Metcalf in small amœbæ of the proteus type. (e) In *A. diploidea* and *A. binucleata*, reproduction of a complicated character has been described.

In the species under consideration, however, we have so far observed only binary fission, multiple fission, budding, and conjugation. No flagellate stage has been observed during four months' work with cultures with sterile precautions, although, previously to this, various flagellates and mastigamœbæ had appeared frequently. While encystation has been watched some hundreds of times, only one amœba has been seen to escape from a single cyst on each occasion.

*Binary Fission* (Pl. VIII.).—The complete cycle has been watched on many occasions and is by far the commonest mode of reproduction. The division is not always into two individuals of equal size, there being every gradation between this and the process of budding. By the jelly method the nucleus is always in view and can be seen to become first ovoid and then elongated, the centre snapping either before or as the body of the amœba separates. Preparations containing dividing forms

can be stained alive on a jelly, the coloured plate showing the stages observed by this means. The specimens can be fixed, but the stain appears to fade from the nucleus more than from other parts of the cell. Division of the body does not necessarily follow division of the nucleus, and in this way multinucleate forms may be produced. Dividing amœbæ placed on a jelly containing alkali or on a firm jelly subjected to the pressure of a cover-glass may be ruptured, and the free nuclei retain the stage of division they were in while within the cell, and can be readily stained to show this. A multinucleate amœba may divide by binary fission into portions containing unequal numbers of nuclei (fig. 11).

*Multiple Fission.*—This has been observed on several occasions, and each time a multinucleate amœba was seen splitting up into from three to five portions, each with usually a single nucleus. This mode of division is particularly common on media containing tyrosin.

*Budding* has been seen once, four small amœbulæ being extruded in about half an hour (fig. 12).

*Conjugation*<sup>1</sup> (Pl. IX.)—This takes place evidently at rare intervals; and as the forms in which we observed it had been growing in augmented auxetic for many days and consequently with extreme rapidity of multiplication, it seems as if conjugation occurs when the reproductive powers of the organism have been called upon to their utmost extent for some time. This fact has of

<sup>1</sup> We employ this term in a liberal sense as meaning the fusion of two individuals which results in the production of a number of smaller ones of the same species.

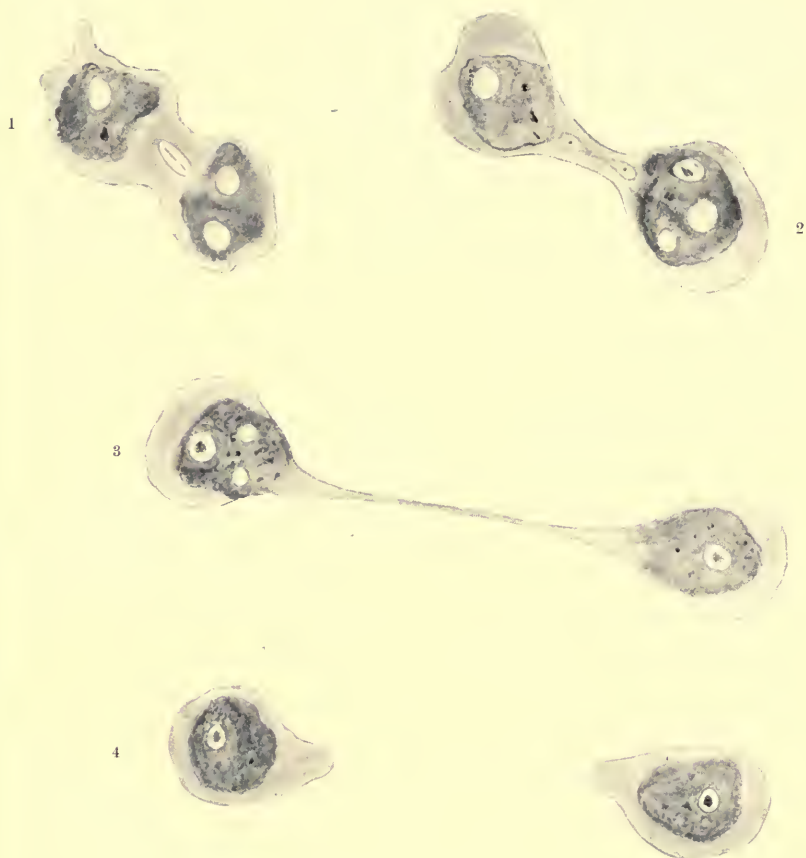

1-4.—Binary fission of amoeba in a mixture of equal volumes of 0·2-per-cent. creatine (auxetic) and 0·2-per-cent. choline hydrochloride (augmentor).





9:15 A.M.

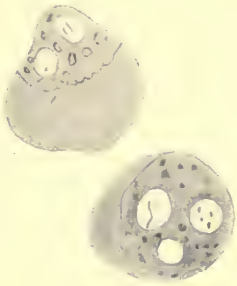

9:32



9:50

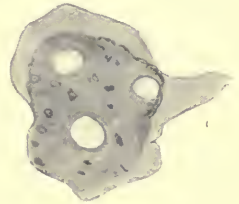

10:18

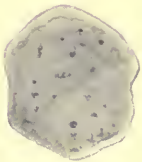

10:36

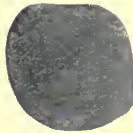

9:57 P.M.



11:3

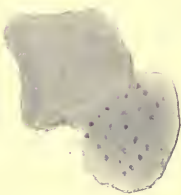

12:14



3:33



Conjugation of amoebæ. The process was watched almost continuously from the time when the amoebæ fused together until the minute amoebule were distinctly formed.



course become quite familiar through the classical experiments on *Paramœcium*, but its occurrence following on the artificial stimulation we have employed emphasises the influence which auxetics undoubtedly have upon the chromatin of the living cell. We have observed the presence of minute amœbulæ, similar to those we have seen produced by conjugation, on some twenty occasions during nine months, and they occur almost invariably, if not always, in cultures in which simple repeated divisions of the amœba do not appear adequate to maintain the species. The process of conjugation is as follows: Two amœbæ in which we were unable to distinguish any difference in size or morphology, gradually came into contact and adhered. In course of time they merged into each other, forming a sac, which we call a "conjugation cyst," and which is difficult to distinguish from the ordinary resting cysts, although it is somewhat larger and the wall is thinner, and the appearance gives one the impression of a bladder full of fluid. The sac formed in this way remains perfectly quiescent for many hours, and then bursts quite suddenly, liberating a glairy, faintly yellow, liquid. If this is watched carefully for a considerable time with a high power and perfectly central illumination, innumerable minute granules gradually appear. These slowly grow larger and begin to exhibit vacuoles and pseudopodia, eventually becoming typical, very active, small amœbulæ. We were unable to distinguish the nuclei in the gametes and think that they had broken up into chromatin masses. The phenomenon which we observed was obviously not due to agglomeration,

and as the amœbæ were not degenerate, we see no reason for attributing it to plastogamic fusion. At the same time, we have no direct evidence of any sexual changes being involved.

#### THE ACTION OF ALKALIES AND ACIDS ON AMŒBÆ

*Alkalies.*—Free amœbæ placed on a jelly containing 0·1 per cent. sodium bicarbonate show diminished movements, and their general body form becomes more rounded, but they are not killed. With 0·5-per-cent.  $\text{NaHCO}_3$ , the amœba exhibits a perfectly circular contour, and the ectoplasm bulges out as the amœba dies and liquefaction of the cytoplasm takes place. With 1-per-cent.  $\text{NaHCO}_3$ , the amœba dies almost instantly, and swells and bursts before it can be properly examined. By cultivation on alkaline media so strong as partially to inhibit bacterial growth, very minute forms appeared which persisted in this condition and ultimately formed small cysts. It has often been noticed that amœbæ on alkaline jellies assume a more rounded type of form, while on acid media they tend to become lengthened out; the significance of this is unknown. Alkalies hasten the diffusion of stains into living amœbæ or their cysts.

The cysts are very tolerant to alkalies and are thereby rendered more resistant; after exposure to 5-per-cent. caustic soda or ammonia vapour for twenty-four hours, free amœbæ will still escape from such treated cysts, but only after several days when transferred to a suitable fresh medium.

*Acids.*—The free forms are very readily affected by citric acid, 0·05 per cent. being sufficient to kill and disorganise them. Amœbæ will, however, excyst on jellies containing as much as 0·2 per cent. HCl. The cysts will tolerate 2-per-cent. HCl (31·8-per-cent. HCl) and 3-per-cent. lactic acid for at least a week. Acids delay the diffusion of stain into the living cell.

### EXPERIMENTS WITH AUXETICS AND KINETICS

*Asparagin (auxetic).*—This was the first auxetic selected, because its ready solubility in water permits of a larger range of concentration being examined than most of the other known auxetics. The moist-chamber method (Method B) was used. On a 1-per-cent. asparagin<sup>1</sup> jelly excystation took place after twenty-four hours, bacteria, yeasts, and moulds growing profusely, particularly the last two. On a 3-per-cent. jelly (boiled for five minutes, slightly acid) excystation took place on the second day, with a slow development of moulds, bacterial growth being almost arrested. On the third day the whole medium was swarming with minute, very active, free forms of the amœba (fig. 13). They were very difficult to distinguish, and it was only their movement which attracted attention to them. It was impossible to follow their changes in shape owing to their extreme motility. A few very small cysts were also present. This culture was closely watched, the growth of moulds continuing

<sup>1</sup> Added to the jelly when cool ; unboiled solutions of asparagin are faintly acid to litmus, while boiled solutions are distinctly acid owing to hydrolysis and formation of aspartic acid.



fairly rapidly, that of bacteria being nearly at a standstill. Observed day by day, the amœbulæ did not increase much in size, as they would on an ordinary medium, but showed a tendency to lengthen out (fig. 14). This increased to such an extent that the amœbæ after twelve days had quite altered their type, becoming very long and slender (fig. 15).

Unlike the young forms, these long, slender adult amœbæ move slowly, like a snail, a small quantity of clear protoplasm being protruded at one end and the rest of the body gliding after this. Short lateral pseudopodia sometimes appear, and the body occasionally rounds up, but always soon recovers its length. The appearance of a similar type has been described by Grüber in cultures of *Amœba proteus* (Pl. VII. B), without, however, any mention as to its mode of origin; and the *A. gracilis* of Penard (Pl. VII. D) resembles it closely. We were at first inclined to attribute the variation to the asparagin, especially as these forms were particularly abundant in the neighbourhood of two small crystals of that substance which had appeared on the surface of the jelly; but neither they nor the minute amœbulæ appeared when the experiment was repeated several times. Transferred to a plain 2-per-cent. agar jelly, these long forms maintain their appearance for about ten days, in gradually decreasing proportion to the ordinary rounded forms which are also present. Placed on a fresh 3-per-cent. asparagin jelly, they at once shrivelled up, and most of them were killed; a few, however, survived and finally became encysted. Their cysts, planted on a plain jelly, gave rise to the





FIG. 14.—Minute amoebulae growing and becoming narrow and elongated.



FIG. 15.—Long, slender forms of the amoeba, comparable to *A. gracilis* (Penard) and form changes seen by Grüber in *A. proteus*.



FIG. 16.—Photomicrograph of a single long form of the amoeba separated from its fellows by the method described in Chapter III., of "placing it" on a jelly surface. The nucleus of the amoeba can just be distinguished.



ordinary round type. In a 0·1-per-cent. citric-acid solution, the long forms were killed outright. This type has since occurred on about half a dozen occasions, always accompanied by the minute amœbulæ already mentioned, and always under conditions adverse to growth, such as deficient bacterial growth on excessively acid or alkaline media, lack of moisture, etc. They have appeared in cultures made from a single cyst kept under sterile conditions, so they are obviously not adventitious forms which have contaminated the cultures. By the method of isolation described later, on eight occasions one of them has been planted on a jelly medium along with bacteria, but has never multiplied (fig. 16). The interpretation we put on their origin is that they are derived from amœbulæ, which under the adverse conditions present are unable to develop into the typical adult form. It is interesting to note that in various organisms deficiency of food has been shown to predispose to the formation of the male sex of a species, and it is possible that here we have an example of an attempt at a differentiation of sex.

*Tyrosin* (auxetic).—Cysts placed on a jelly film saturated with tyrosin (3-per-cent.) produce free forms in twenty-four hours, which become larger, and contain more multinucleate types (fig. 17) than on an ordinary plain 2-per-cent. agar medium. It is interesting that tyrosin has a somewhat similar effect on certain bacteria, as a pure culture of *Bacillus fluorescens liquefaciens* on media containing this auxetic exhibited very large forms of the individual

bacilli, and even grew into long chains, a phenomenon which is unusual in this species. Tyrosin had already been employed by H. B. Fantham in his experiments with *Entamoeba coli*. He found that this substance reduced the period of the life-cycle of the amœba and hastened the division of the nucleus (within the cyst) into eight daughter nuclei. It was found by Wherry, during his experiments with amœbæ, that reduced oxygen tension predisposes to amitosis and the production of multinucleate forms, and conversely a free supply of oxygen favours mitosis and division of the cytoplasm. We regard this as an important discovery, and the effect of tyrosin can be correlated with this view. The tyrosin is readily oxidisable, as is shown by the culture media rapidly turning black, and this would obviously diminish the amount of oxidising substances produced by the bacteria, which are available for the amœba, and would reduce the efficiency of oxidation processes which may play some part during division of the cell.

*Creatine (auxetic) and Choline (kinetic and augmentor)*.—In the first place three live slides were made simultaneously from the same culture of amœba. One acted as control, using tap water, and the others contained 0·005-per-cent. solutions of creatine and choline respectively. The multiplication was so marked in the latter compared with the control that it was decided to repeat this and make an actual count of the numbers of amœbæ present. The creatine caused some increase, but not to the same extent as the choline. Three live slides (A, B, C) were

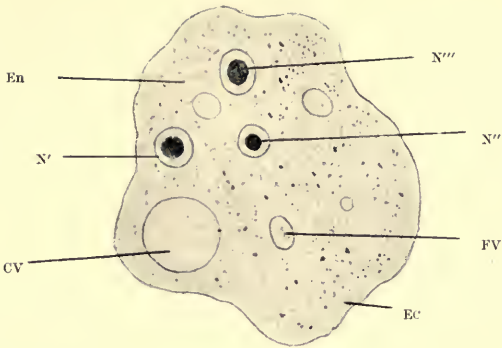

FIG. 17.—Jelly method. Large multinucleate form of the amoeba. Letters as in Fig. 5.



FIG. 18.—Divisions induced in the resting winter spores of *Polytoma granulosa* by auxetics (after Drew).

- A. Control and division in suprarenal extract and cadaverine.
- B. Free forms from induced divisions.

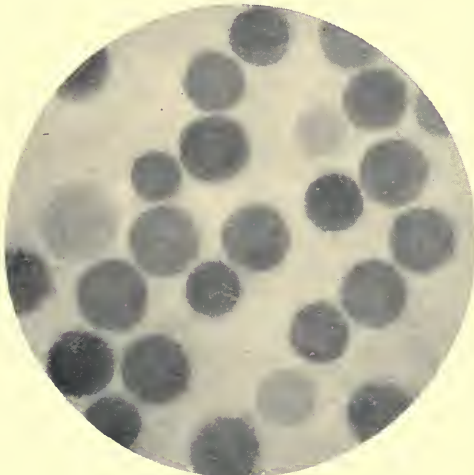

FIG. 19.—Photomicrograph of amoeba cysts.





again prepared, the solutions in this case being as follows:

A contained 0.005-per-cent. choline.

B contained 0.2-per-cent. choline.

C contained distilled water.

The average number of amœbæ in 50 fields at the beginning of the experiment was—in A 5, in B 7, in C 5 amœbæ per field. Recounts were made after twenty-four hours, and gave:

A. 13 amœbæ per field.

B. 18     "     "     "

C. 6     "     "     "

Recounts after three days gave:

A. 25 amœbæ per field.

B. 42     "     "     "

C. 10     "     "     "



Judging from these figures the choline stimulates multiplication very rapidly. In both A and B the average number of amœbæ per field was more than doubled in the first twenty-four hours, and about doubled again in the following two days. In the control scarcely any increase took place in the first twenty-four hours, and subsequently two days were taken before the numbers were doubled. It will be observed that 0.005-per-cent. choline was nearly as effective as 0.2-per-cent. Partly with the object of repeating the above experiment, it was decided to make an absolute count of all the amœbæ on the live slide. A uniform suspension of amœbæ was made in 5 cc. of distilled water. Two very small cover-glasses were then taken, and an

equal volume of this mixture placed on each. The cover-slips were then applied to live slides, in the one case (A) containing 0·2-per-cent. choline, and in the other case (B) distilled water. Counts were then made of the number of amœbæ on each slide, and were as follows, A 34 and B 26. After three days a recount was made, and gave A 207 and B 88. It is important to note that when a certain strength of these auxetics and kinetics is exceeded the amœbæ are poisoned and multiplication is retarded. There is thus an optimum dose for each substance. Without making actual counts it appears to us that the most effective mixture to employ as an auxetic for amœbæ is 0·4-per-cent. creatine with 0·4-per-cent. choline. An apparent increase was found with cadaverine and asparagin, but possibly the best strength to employ has yet to be found. With tyrosin there is a great increase, the best strength to employ being a 0·01-per-cent. solution, and the effect is further increased if an equal volume of 0·02-per-cent. choline is added to it. Tyrosin seems to take some time before much increase is apparent, and this may be explicable by the abundance of binucleate forms produced by the auxetic, and by the fact, already mentioned, that the amœbæ under the influence of tyrosin become on the average very much larger than normal, many indeed being describable as giant forms of the species.

Thus, auxetics, and especially augmented auxetics, undoubtedly in certain strengths cause great proliferation of amœbæ.

*Radiosa types.*—During prolonged work with this amœba, it was noticed that if the normal

forms were grown on live slides with augmented auxetics a gradual change in appearance took place. Employing two live slides, No. 1 containing equal volumes of 0·2-per-cent. creatine and choline, and No. 2 equal volumes of 0·5-per-cent. solutions of these substances, two distinct types of amœba were obtained, which are called for convenience *Radiosa* types 1 and 2. Type 1 (fig. 20) was obtained with the weaker auxetic, and shows a central body composed of granular protoplasm, with long, blunt pseudopodia radiating irregularly from the centre. Progression is by a kind of rolling motion, and changes in the form of the pseudopodia are very sluggish. This type was very persistent, and was cultivated for weeks. Commencing with only the normal forms, the majority of amœbæ had assumed this form in about ten days. Type 2 (fig. 21) was of rarer occurrence, and chiefly differed from type 1 in the pseudopodia being very much longer, and thinned out to very fine filaments at their distal ends, and alterations in the shape of the pseudopodia were much more rapid than in type 1. By the jelly method, it was found that these forms are more difficult to stain than the ordinary forms, thus showing that their coefficient of diffusion has been raised during their morphological changes. Although the solutions in which they were obtained were slightly alkaline, the effect must be attributed to the auxetics and kinetics present, as they could not be cultivated in pure alkaline solutions of various strengths, and have been grown for some generations on a neutral 2-per-cent. agar jelly containing 0·2-per-cent. creatine only, and

found to be very persistent. The species described as *A. radiosa* has been said to show neither nucleus nor contractile vacuole, and although, in our case, a single nucleus was occasionally visible, it was more usual to find a number of spots which could be stained, suggesting that the nucleus had broken up into chromidia. The first type described above appears to resemble the species described as *Amœba polypodia*.

The act of mechanical transference of a loopful of amœbæ to a fresh medium often produces a temporary condition similar to the second type, which is maintained for about ten minutes, the typical form of the amœba being then gradually resumed. This condition may also appear when a culture of amœbæ is exposed to a faradic current, a few of the cells assuming this form as the contact is made or broken, so that in about five minutes nearly all the amœbæ have become altered. Young cultures are more liable to these changes than old ones, and they may be produced on acid or alkaline media. Doflein has described a similar change in *A. vespertilio*, and Verworn describes it as produced by caustic potash. On jellies containing excessive amounts of salts, the amœbæ often project tentacles with bulbous ends, which are waved about, and may become detached or fragmented.

It is possible that the mechanical interference produces a certain amount of cell-death, which in its turn sets free auxetics and kinetics, and thus the appearance of these types of amœbæ can be explained.



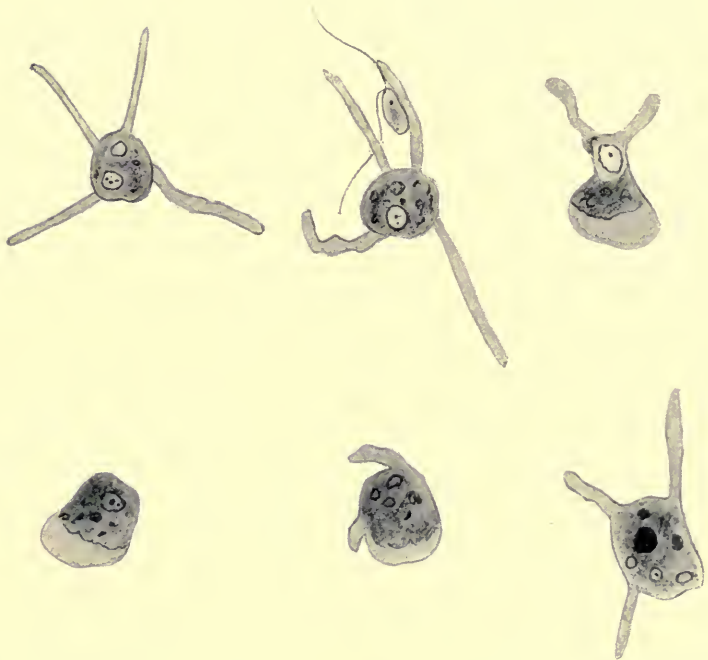

FIG. 20.—Radiosa type No. 1, showing ingestion of a flagellate and assumption of ordinary form. Equal volumes of 0.2-per-cent. creatin and 0.2-per-cent. choline hydrochloride.







FIG. 21.—Radiosa type No. 2 after eight days in a mixture of equal volumes of creatine (0.5 per cent.) and choline (0.5 per cent.).



## SUMMARY

A brief general note on amœbæ is given, and the characters of the type we have employed are described.

Special methods of examination suitable for the study of the action of chemical agents on amœbæ are shown.

The advantages of the jelly method are pointed out, and *in-vitro* staining of the amœba while it is alive is explained.

The stages of nuclear division of the amœba are shown by the jelly method of staining.

The characters of the movements, and the modes of nutrition of the amœba are described in detail.

The methods of reproduction of this amœba, so far as they have been observed, are compared with those which have already been described in other species.

The process of conjugation has been watched, and results in the production of numerous minute amœbulæ.

The occurrence of a long, slender variety of the amœba has been observed, and its possible significance has been touched on.

The action of auxetics and kinetics in hastening multiplication has been demonstrated, and the effect of one of the former (tyrosin) in producing multinucleate forms is explained.

The so-called "radiosa" types of amœba have been produced by the action of auxetics and kinetics.

## II

# EXPERIMENTS ON THE CAUSES OF ENCYSTMENT AND EXCYSTATION OF AMŒBA

### THE PHENOMENON OF "ENCYSTMENT"

*Introduction.*—It is well known that amœbæ, in common with many other protozoa, have the property of assuming a resting stage under conditions of environment which have been somewhat vaguely described as "adverse to their welfare." This process consists in the formation of a resistant envelope to the delicate protoplasmic contents of the organism, and is termed "encystment." The species of amœba under consideration is no exception to the rule, and the cysts formed in this way are a prominent feature in all methods of artificial cultivation. We believe that this cyst formation should not be regarded as a phase in the true life-cycle of the amœba, but should be considered merely as a temporary condition, which is assumed to protect the organism until the surroundings are again suitable for its existence in the free living form. We are not aware that the actual causes of this phenomenon have hitherto been thoroughly investigated from a

chemical point of view, it having been usually attributed to such agencies as drought, lack of food, etc., the amœba being endowed with a sort of intelligence which enables it to defend itself against these injurious conditions. Our contention at the outset was that the amœba is actually compelled to protect itself by the action of soluble substances in the environment, which are of the nature of poisons, and which are produced under natural conditions by those bacteria that are invariably associated with the growth of amœbæ.

After confinement for a variable length of time within the walls of the cyst the amœba is enabled to escape, and the series of changes which take place during this process are known as "excystation." On *à priori* grounds, and from our previous experience with *Polytoma* (fig. 18), we were inclined to think that the causes of these changes must also be looked for among bacterial products, which act on the cyst walls from without, and that the possible influence of any causes of excystation acting from within the cyst were only of a secondary nature. The experiments described in this chapter indicate the preliminary steps undertaken to elucidate these problems.

*The Cysts.*—The typical "dauer" cysts in this species are spherical refractile bodies about 10–12  $\mu$  in diameter (fig. 19). In cultures on jelly media, however, their shape is liable to be modified by mutual pressure, and they may be kidney-shaped or otherwise irregular. Their size also varies considerably, and many may be twice or even four times as large as others. They may be described as consisting of a central dense mass of protoplasm, containing



one or more nuclei and occasionally a few vacuoles, in which bacteria may sometimes be seen. Investing this closely is a thin layer, the "endocyst," and in cysts which have only recently been formed there may be nothing more visible. Gradually, however, the "ectocyst" expands, and the protoplasmic contents, with the endocyst encircling them, contract. Thus in older cysts we find, starting from the periphery, first the ectocyst, which is of considerable thickness and is usually rather irregular in outline, then a clear space, and finally the endocyst, a resistant membrane which closely invests the amœba within. By means of the live slide previously described, one can study the process of encystment induced by choline, etc., and the changes observed appear to throw considerable light on its cause. The amœba becomes more sluggish and globular, and a clear halo of ectoplasm becomes visible at the periphery. Changes which appear to be of a degenerative nature gradually occur in the ectoplasm, and the endoplasm contracts and gets markedly denser, its outer margin forming the resistant endocyst. Subsequently the thick irregular ectoplasmic layer contracts and becomes more hyaline, till it forms an almost invisible layer closely investing the endocyst. There appears to be a loss of water in this process, as the resulting cysts are considerably smaller than the amœbæ; but we have no evidence that it actually passes out of the cell, and osmosis does not appear to us to play an essential part in the process. Possibly the water is used up in some chemical synthesis and is restored when excystation occurs. From our experiments it appears that



encystment is due to a gradual poisoning of the amœba causing changes to occur in the ectoplasm, which finally becomes an almost impermeable wall and thus prevents the further absorption of toxic substances.

In the process of excystation the ectocyst swells up and becomes fainter in outline; soon a series of minute vacuoles develop in the amœba just within the endocyst, and protrusions of the contained protoplasm are seen to pass through weakened spots in this membrane. In course of time the endocyst gradually disappears, and finally the ectocyst ruptures and the amœba escapes and leaves the empty cyst wall behind. On two occasions we have been able to compare the "dauer" cysts with what we have already termed "conjugation cysts," and the following differences were noted: the latter exhibit neither ectocyst nor endocyst, but merely consist of fluid or semi-fluid contents invested by a cuticle; indeed, they give one the impression of a minute globular bladder with a faintly yellowish tint. While experimenting with a kinetic jelly containing atropine, cysts having the characters above described were seen to burst, while the "dauer" cysts were unaffected, the conjugation cysts thus appearing to be more permeable and more easily killed.

*Influence of Drought.*—It should be made clear at once that it is not actual deficiency of moisture which could be supposed to cause the encystment of an amœba. It is incredible to us that, under any circumstances, the deprivation of water during the drying up, say, of a pond, could be so gradual as to allow the amœba time to encyst. On the other

hand, amœbæ do not stand rapid drying; they maintain their appearance unchanged so long as there is the least possible quantity of moisture adhering to them, and then suddenly assume a globular shape and rapidly die. We had already formed the opinion that it is probably the concentration of injurious bacterial products in solution during drought which is the primary cause of encystment, and it will be shown that amœbæ can be made to encyst on a live slide by means of such a substance as choline. To determine if encystment will occur on gradual drying in the absence of such bacterial products, cultures were made by the moist-chamber method, and when sufficient amœbæ had wandered from the site of inoculation, the Petri dishes were exposed to the air, so that the jelly film could slowly dry up. It was then found that only those amœbæ near the centre of the growth encysted, while those far distant, which were comparatively bacteria free, persisted in the free state until the whole of the jelly had dried up, when they rounded up and burst, liberating their nuclei, which remained visible for several days. Therefore encystment is evidently not due to gradual drying. It may be pointed out that amœbæ can also encyst when water is abundant and bacterial products are apparently dilute, but we think this is explicable by the fact that the condition of the medium in which an amœba is found is no indication of the nature of the immediate environment of an individual, since the bottom layers of a solution which contains amœbæ and multiplying bacteria are not measurable by the average condition of the whole medium. Again,

the idea that cyst formation may be due to an increase of saline content, caused by the concentration during drought, resulting in osmotic-pressure effects, is contra-indicated by the fact that both free amœbæ and cysts may exist together either in distilled water or in salt solutions of considerable strength.

*Effect of Starvation.*—This condition can be experimentally brought about by washing away the bacteria (which constitute the natural food of the amœbæ) from a culture with these organisms on a jelly film. Cysts are first planted on the jelly, and the amœbæ which escape are allowed to multiply for a few days. The moist-chamber method is employed, using the modification in which the jelly film is made on a microscope slide, which is then inverted, resting on corks over water. Full-grown amœbæ will then be found at a considerable distance from the original site of inoculation. After washing off most of the bacteria with a gentle stream of water, the amœbæ, which adhere firmly to the jelly, gradually lose their characteristic appearance, the granular contents accumulate at one end and the clear cytoplasm at the other. The movements become sluggish, the food vacuoles scanty, and the contractile vacuole becomes slow (fig. 22). This condition is maintained for days unchanged, and, on the addition of bacteria, the normal type is gradually assumed. There is no attempt at encystment, as bacterial products are absent. The amœbæ which have been obtained in this way may be said to exhibit one of the "depression periods" to which protozoa are at times subject.

*Quiescent Type of Amœba.*—Cysts were placed



on a plain 2-per-cent. agar jelly made faintly acid with citric acid, and covered with a shallow layer of distilled water containing a little litmus which turned red. The acid water was poured off daily and the cysts examined. Free amœbæ were observed on the fourth day, bacteria growing very slowly, and the medium remaining acid throughout. Sluggishly moving amœbæ and cysts were present together for about a week, the relative proportion altering very little, whereas under normal conditions one usually finds a rapid increase in the number of cysts in the same period. After ten days the preparation was allowed to concentrate slowly, and it was noticed that the amœbæ did not encyst, but simply became more or less rounded and motionless (fig. 23). This resting condition without encystment has also been produced on alkaline media, where the alkalinity reduced bacterial growth to a minimum. The appearance of these quiescent amœbæ is quite distinct from that of cysts, as they have no definite wall and their shape is more irregular. They cannot be mistaken for dead amœbæ, which are usually quite spherical. They are probably forms which are unable to encyst as the bacterial products to which they are exposed are too dilute to effect this.

*Influence of Bacterial Products.*—The next experiments were undertaken to obtain more positive evidence as to what the conditions are which cause encystment, and if possible their mode of action. The first point noticed was that amœbæ are influenced greatly in this respect by the amount of bacterial growth present: for instance, those

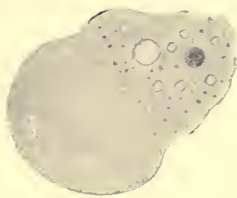

FIG. 22.—Amoeba showing the effects of starvation. Note the bulging out of the ectoplasm.

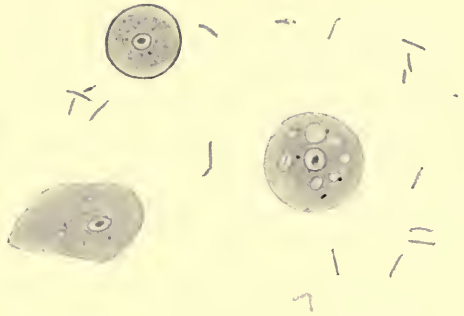

FIG. 23.—Quiescent forms of the amoeba. One cyst for comparison. Note the few bacteria.

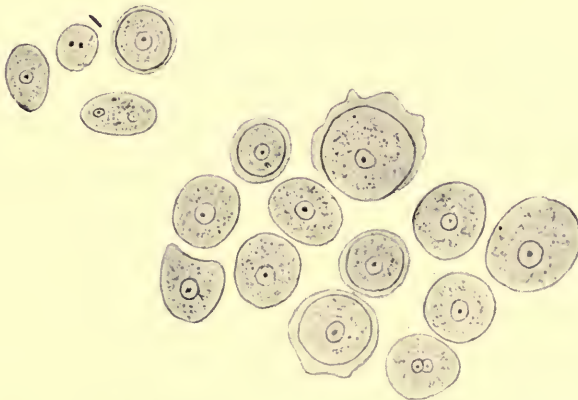

FIG. 24.—A group of cysts separated from living bacteria by 3-per-cent. formalin. Preparation of "pure mixed cultures."

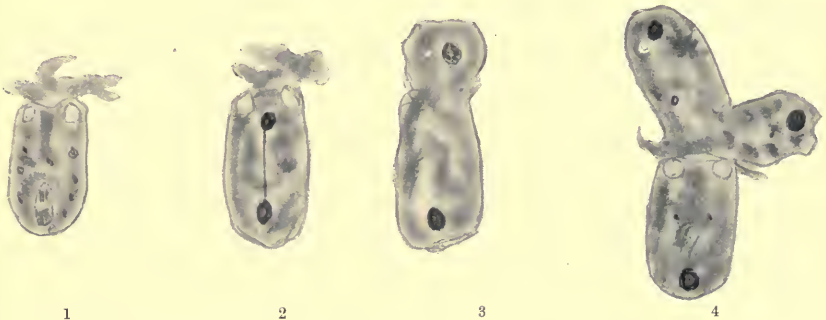

FIG. 25.—1-4, Division of an amoeba-like organism which, infected some of the cultures.





amœbæ usually encyst first which are surrounded by dense masses of bacteria. We have been asked frequently how long the free amœbæ live before they encyst again. This appears to depend entirely on the dose of bacterial products, such as choline, etc., to which they are subjected. Under certain conditions, such as starvation and drying, they will not encyst at all, as already pointed out; and recently, by means of cultures without living bacteria, amœbæ can be compelled to leave their cysts, and grow and multiply for weeks without encysting. On the other hand, living amœbæ placed in old infected cultures are killed outright. In ordinary circumstances the poisoning of the amœbæ by bacterial products is a gradual process, and they are thereby allowed sufficient time to encyst. On the live slide already described the greatest difficulty we had to contend with was the inability to make the amœbæ encyst, as the slow current beneath the cover-glass removed most of the bacteria and their products from the sphere of action. A little tilting of the slide increased this effect, and the amœbæ lived for weeks in the free state. It is, however, possible to make them encyst at will by means of choline, cadaverine, or a mixture of the products of growth of *Staphylococcus albus* grown in Dunham's peptone water for a week at 37° C. The strength of substances necessary to cause encystment are, as nearly as we can ascertain, choline 1 per cent. (it is more powerful if it is old, containing neurine) and cadaverine between 0·8 per cent. and 1 per cent. The method we use is as follows: amœbæ are first grown vigorously on the live slide by means of

a mixture of creatine and choline 0·2 per cent. (equal volumes). This is then replaced by the pure choline or cadaverine 0·2 per cent. for 24 hours, then 0·4 per cent. for 12 hours, and then 0·8 per cent., when some will encyst, and many are preparing to do so. A 1-per-cent. solution is finally employed, and in from 12 to 24 hours all amœbæ will encyst. As a general rule, if amœbæ are placed directly into 1-per-cent. cadaverine or choline they are poisoned too quickly to encyst. From these experiments we conclude that the process of encystment is to protect the amœbæ from bacterial products in excess, and that limited cell-death occurs at the periphery, and the products of this protoplasmic degeneration form a cyst wall.

*Summary and Conclusions.*—From the results of these experiments it will be seen that an amœba is able to protect itself against poisoning and death brought about by certain bacterial products in its environment. The nature of two of these products is known, namely, choline and cadaverine. These substances have been shown in the first chapter of this volume to be capable of accelerating the multiplication of the amœbæ. We have thus an example of totally different effects (viz. reproduction and poisoning leading to self-protection) being brought about by the same substance according to the dose in which it is employed. We think an analogy may be drawn between the action of a kinetic such as choline on an isolated cell such as an amœba, and the effect of the chemical substances which are liberated during “chronic irritation” of the tissues of the higher animals.

The irritation produces injury and death of some of the cells, and the broken-down products (auxetics and kinetics) may, if sufficiently concentrated, act deleteriously on the neighbouring living cells, and, by causing degeneration of the outer layers of their protoplasm, may render them more resistant, and prevent further absorption of the injurious substances. For this to take place, however, a sufficient dose of these chemical agents will be necessary, as the first effect of the liberation of auxetics and kinetics is to cause proliferation of the neighbouring cells. It appears then that the effect of auxetics and kinetics depends on their concentration; in small doses they act as excitors of cell-reproduction, while in larger doses they (or at any rate the kinetics) act as cell-poisons. The influence of certain poisonous substances such as alcohol, uric acid, the toxins (?) of syphilis, etc., in producing sclerosis of tissues is well known, and it appears probable that the auxetics and kinetics liberated by cell-death may be effective in the same way. These experiments have considerable bearing on the theory propounded and developed by this Research Fund (see the former volumes) that cancerous tumours are due to excessive cell-proliferation brought about by the action of auxetics and kinetics. If the accumulation of these substances becomes excessive they may now act as poisons to some of the cells of the growth while promoting excessive cell-division in other parts; and in this way might destroy part of the tumour and cause ulceration, at the same time giving rise to infiltration in other parts of the tissue. There is in fact in a rapidly growing



malignant tumour a sort of balance, just as in the case of an amœba in relation to the bacterial products to which it is exposed, and the chemical conditions present as regards the quantity and quality of auxetics and kinetics may possibly determine the question as to whether the tumour will continue to grow, or will break down and ulcerate.

### THE PHENOMENON OF "EXCYSTATION"

The experiments on this subject were undertaken to find out the nature of the substances produced by bacteria in the environment of amœba cysts, which we believed to be responsible for the dissolution of the cyst wall and the liberation of the free amœba.

*Theoretical Considerations.*—Various suggestions have been made from time to time to explain why an encysted organism, such as an amœba, develops into the free living form on transferring it to a fresh medium. The popular expression is that the amœba escapes when conditions are again suitable for its existence in the free form, in which case the employment of such a phrase obviously implies that these conditions must form the starting-point in the process, whatever may be the actual changes taking place within the cyst. The expression "suitable conditions" is capable of two interpretations as follows: Firstly, it may be said that the amœba has been removed from the presence of those substances which have brought about the encystment, and that excystation will accordingly now take place. If one were to accept

such a view it would be necessary to assume that a cyst would develop when placed in pure water only, in which case the escaping organism would either die of starvation, or, if this theory were correct, would encyst again. We now know by actual experiment that neither of these events takes place (see later). Excystation does not take place without the influence of certain bacterial products (the nature of which we have to some extent been able to ascertain) acting on the cyst from without, nor does encystment occur in the absence of other products, which appear to be of a poisonous nature. Secondly, the excystation may be attributed to the fact that the term "suitable conditions" really means the addition of a fresh supply of food or something which was absent in the old medium. In other words, it is now the presence of some added stimulus in contrast to the absence of harmful substances which was expressed by the first view. We find from our experiments, however, that there is no question some added stimulus is essential for excystation to take place; and although we have not adduced any positive evidence that removal of injurious products is necessary, it can safely be assumed that excystation could not occur in the presence of a sufficient degree of concentration of those substances which cause the encystment. As a matter of fact, we find that it *is* the presence of food, namely bacteria, which acts as the stimulus to excystation; but its action is not due to its mere existence in the neighbourhood of the cysts, but is felt through the production of chemical substances which are capable of weakening the cyst

wall. It will be shown later that these substances are probably of the nature of ferments, and that their action is increased by the presence of kinetics which are also produced by the bacterial growth.

As regards the two main processes which have hitherto been suggested by others to be responsible for the phenomenon in question, namely, the action of an internal ferment and the influence of alterations of osmotic pressure, we have no proof that either of these plays any part; but we think that, if they have any influence, it is only a secondary one, and that they are unable to act on the cyst without the assistance of other factors.

*Rate of excystation dependent on the concentration of dissolved substances in the surrounding medium.*—The first indication of this fact was the observation that excystation invariably takes place sooner on a jelly surface than in a solution. In the former case the immediate surroundings of the cysts are more constant than in a solution in which physical processes are continually at work removing the bacterial products. For the same reason, excystation is more rapid if the jelly is merely saturated with moisture than if it is covered with a layer of liquid. Again, salts, which have been shown to delay the diffusion of soluble substances into living cells, have a similar effect in delaying excystation, although their effect is not marked. For example, cysts selected from the same stock, so that their age and resistance could be regarded as uniform, were found to discharge their contents in tap water quicker than in solutions of sodium chloride or sodium citrate. The complexity of the factors involved in the process, such as the nature



of the bacteria present, their rate of growth, and the resistance of the cysts, etc., makes precise figures of no value, but from general observations we feel convinced that a balance exists between the amœbæ and accompanying bacteria which is more than that of a mere food supply. Thus, peptone broth has been found useless for ordinary cultural purposes, as the bacterial growth is so rapid that the amœbæ either do not excyst at all or are rapidly killed after they have done so. With 0·1-per-cent. peptone water, however, cultures with a mixture of bacteria can be maintained.

*Age and resistance of cysts and the time factor in excystation.*—It is most important to recognise that in any culture of amœbæ the cysts vary in age. Those amœbæ surrounded by a dense bacterial growth may encyst long before those which are comparatively free from bacteria. For this reason it is of no value to select an individual cyst or even a dozen or so in any attempt to discover the cause of excystation. As pointed out by Musgrave and Clegg, the resistance of cysts increases with their age, and younger cysts will therefore develop more rapidly than old ones. In order to minimise the error of random sampling, it is necessary to select some hundreds of cysts for each experiment, and, by choosing young ones (*e.g.* from cultures only a few days old), one can avoid the tedious waiting which the choice of older ones involves. Living cysts can be recovered from old cultures which have been exposed to considerable ill-treatment, *e.g.* a temperature of 56° C. for half an hour, or 4-per-cent. solution of hydrochloric acid (31·8 per cent. HCl) for three days, or 5-per-

cent. solution of caustic soda for a week; they will stand severe pressure under a cover-glass, exposure to free hydrogen, oxygen, or ammonia for twenty-four hours, and some will stand 3-per-cent. formalin for a week. They can also be dried over sulphuric acid or phosphoric pentoxide for six weeks, and they can be left on agar slopes for six months without obvious deterioration.

*Effect of alkalinity of the medium on excystation.*—Early in the work it was suggested to us that variations in the reaction of the medium might play an important part in the processes of encystment and excystation, and to determine this point a solution of caustic soda was used, from the fact that in low degrees of concentration this substance will inhibit bacterial growth. It was thought that, by this means, excystation might be effected in the absence of the products of the growth of living bacteria, and this was attained by the use of a 0.1-per-cent. solution as follows: To each of six test tubes was added 2 cc. of nutrient peptone broth (faintly alkaline). Each of these was rendered alkaline to a different degree by the addition of caustic soda (2.5 per cent.), and the balance was made up to 5 cc. in the following way:

AMOUNT OF ALKALI IN TUBES

No. of tube	No. of cc. peptone broth	No. of cc. dist. water	No. of cc. caustic soda (2.5 per cent.)	Per cent. NaOH
1	2	2.98	0.02	0.01
2	2	2.90	0.10	0.05
3	2	2.80	0.20	0.10
4	2	2.50	0.50	0.25
5	2	2.00	1.00	0.50
6	2	1.00	2.00	1.00

TABLE I.—THE INFLUENCE OF CAUSTIC SODA ON BACTERIAL GROWTH IN RELATION TO EXCYSTATION OF AMOEBAE.

No. of tube	Per cent. NaOH	First day	Second day	Third day	Fourth day	Fifth day	Bacteria
1	0·01	Growing	Abundant	Abundant	Abundant	Abundant	Bacteria
		No	A few	Abundant	Abundant cysts	More cysts than amoebae	Amoebae
2	0·05	Slight growth	Growing	Fairly numerous	Numerous	Numerous	Bacteria
		No	No	A few	Many	Cysts and amoebae	Amoebae
3	0·10	None	None	None	None	None	Bacteria
		No	No	No	A few	A few	Amoebae
4	0·25	None	None	None	None	Sixth day None	Bacteria
		No	No	No	No	Sixth day A few	Amoebae
5	0·50	None	None	None	None	None	Bacteria
		No	No	No	No	No	Amoebae
6	1·00	None	None	None	None	None	Bacteria
		No	No	No	No	No	Amoebae

Cysts from the same stock were placed into each of these solutions, and each sample examined daily with special reference to excystation in relation to abundance of bacterial growth. See Table I., p. 61.

In sample No. 3, although there was no apparent bacterial multiplication at the end of four days, excystation had taken place, and the culture also contained a number of minute, very active amœbulæ (diam. about  $0.5\mu$ ). Two days later similar small amœbæ appeared in No. 4. These preparations were observed for a fortnight, the small forms persisting in this condition, possibly through lack of food. The tendency of amœbæ to remain in the free state in the absence of bacterial products was very noticeable. There were at least six amœbæ to every cyst at the end of the fourteen days, under ordinary circumstances the ratio being at least in the opposite direction. In samples 1 and 2, with obvious bacterial growth, encystment began after four or five days, and at the end of a week there were more cysts than amœbæ. The cysts in the stronger alkali solutions appeared to be uninjured, and those from sample 6 excysted on a fresh medium.

From these results it is clear that it is not the alkalinity of the medium which initiates the excystation, because, if so, one would then expect increasing strengths of alkali to hasten the process, whereas the converse is the case. Also cysts will excyst on an acid medium (citric or hydrochloric acid). It is probably some extract of the bodies of the bacteria (which were added to the solution along with the cysts) which is the effective agent,



and it seems to act best when the alkalinity is about 0·01 per cent.

*Excystation hastened by choline (hydrochloride).*—Some experiments have already been carried out by other authors with the object of artificially producing excystation in the absence of living bacteria with various tissue extracts and ferments, although without much success. The following data indicate that among bacterial products which hasten the process of excystation, even if they do not originate it, dilute solutions of choline (which is a kinetic) are effective.

Three live slides were prepared, and a number of cysts from the same culture placed on each. Solutions were employed as follows, and the results observed at the end of twenty-four hours.

(1) Distilled water.

(2) Sodium chloride, 0·2 per cent.

(3) Choline (old, containing neurine), 0·2 per cent.

After twenty-four hours :

In (1) very few have excysted.

In (2) none have excysted.

In (3) many have excysted.

The experiment was then modified as follows, again using three slides at the same time :

(1) Distilled water.

(2) 0·5-per-cent. sodium bicarbonate.

(3) Equal volumes of 0·5-per-cent. creatine and 0·2-per-cent. choline, the mixture being made alkaline with soda bicarb. to 0·25 per cent.

After twenty-four hours :

In (1) none have excysted.

In (2) a few have excysted.

In (3) a large number have excysted, and vast numbers of amœbulæ have appeared, resembling the forms derived from conjugation.

*Excystation induced by products of bacterial growth.*—The next steps were carried out with cysts which had been freed from living bacteria. Before we could prove the action of bacterial products on the cysts, it was obviously necessary to obtain a culture of cysts which were free from organisms. Then, having accomplished this, it only remained to add various forms of bacteria deliberately to the cysts and watch the results. In order to free the cysts from bacteria, in the first place a large quantity of cysts from an impure culture was exposed to formalin (3 per cent.) for a week, the reagent being subsequently thoroughly washed away. After many failures for various reasons cysts were obtained apparently free from all living bacteria (fig. 24), no growth of the latter taking place when plated on a sterile nutrient jelly. No excystation of the cysts, however, occurred on plain 2-per-cent. agar jellies, but when transferred from these to live slides with tap water and bacteria the amœbæ were set free again on the third day. A culture of *Staphylococcus albus* was then made in 1-per-cent. peptone water containing 0·5-per-cent. sodium chloride, and after a week's growth the solution was passed through a Chamberland filter. A 2-per-cent. plain agar slope was smeared thickly over with the sterile peptone culture, and the formalised cysts as prepared above planted on it. After two days the tube was examined, and many free amœbæ had escaped, there being no sign of bacterial growth. The



products of growth of *S. albus* were less effective on a live slide than on a jelly medium. A similar experiment carried out with a mixture of the common bacteria found in tap water gave the same result, excystation taking place in response to some stimulus from the soluble products of bacterial growth.

While the preceding experiments were in progress, we had been endeavouring to find a more reliable means of separating the amœba cysts from living bacteria, which would be available as a routine process, and having by this time been able to accomplish this, and to obtain cultures of amœbæ with pure strains of bacteria, we were in a better position to test the working hypothesis, *i.e.* that excystation is due to bacterial products—on which the former experiments were based. The details of the stages in the separation of amœbæ from living bacteria were of a complicated nature, and they are, for convenience, described later in a separate chapter (Chap. III.). It is only necessary to point out that, from this time onwards, all the experiments were carried out with amœbæ which were in culture either with a pure strain of a bacterium or with no living bacteria at all.

*The effect of gelatin liquefying and non-liquefying bacteria on excystation.*—While trying the effect of gelatin media on the growth of amœbæ in impure cultures it occurred to us that by employing pure cultures with bacteria which liquefy gelatin and with those which do not, some difference in the rate of excystation might be made out. With this object a series of pure mixed cultures with a variety of non-liquefying bacteria was made, em-

ploying cysts which had been freed from living bacteria by means of hydrochloric acid (2 per cent.). The cysts were taken from the same culture, and in every case excystation was later than in controls made with liquefying bacteria, and in some of the former, which grew slowly, very few living amoebæ could be seen at the end of a week. These results at least indicate that some of the bacterial products necessary for excystation may be of the nature of ferments similar to those which are capable of liquefying gelatin.

*Excystation induced by the soluble remains of the dead bodies of bacteria.*—To determine if excystation occurred in the absence of any stimulus from without, cysts in pure mixed culture with *B. fluorescens liquefaciens* on an agar slope were treated with 2-per-cent. HCl for twenty-four hours, which kills the bacteria, and were then washed thoroughly with sterile water, the cysts, plus dead bacteria, being placed on fresh plain 2-per-cent. agar media. After a few days a few living amoebæ were found, but only in places where they were surrounded by dense masses of dead bacteria. The vast majority of cysts were quite unaffected. In order to find if the accompanying dead bodies were responsible for the excystation that occurred among the few cysts, three live slides were prepared as follows:

In (A) pure water was circulated through the slide. In this way the dilution of soluble products was so great that no excystation took place during the whole period of observation (one week). In (B) a solution of 0.1-per-cent. choline hydrochloride. No excystation took place, and no difference from A was detected. In (C) a sterile

solution containing the products of growth of *B. fluorescens liq.* in nutrient gelatin, the bacteria having been killed by means of chloroform.<sup>1</sup> In twenty-four hours the majority had excysted, but it was observed that they did not multiply appreciably, and gradually died out through lack of nourishment. They did not encyst again. These experiments were carried out with a jelly on the slide, and in A and B no living bacteria were at any time visible, and only appeared in C after three days. We think the experiment is conclusive that excystation will not take place in pure water or in water in which the soluble products of bacteria are diluted to such an extent as to be negligible. Organically pure ammonia-free water was used in these experiments.

*Excystation brought about by bacterial extracts and ferments.*—The next experiment was to try the “chloroformed solution” of the products of growth of *B. fluorescens liq.* on cysts which had been freed from living bacteria by hydrochloric acid in the usual way. This time it was smeared over the surface of a plain 2-per-cent. agar slope, a control tube being made with distilled water. Examined in the course of twenty-four to forty-eight hours, the control showed a few scattered amœbæ in those areas thick with dead bacteria, while in the tube with the bacterial extract the jelly was covered with living forms. Watching this culture,

<sup>1</sup> A nutrient gelatin stab of the selected bacillus is made, and after a few days the liquefied mass is treated with pure chloroform shaken well and allowed to stand. The upper layer consists of an aqueous solution of the bacterial products, and can be easily removed and filtered through a Chamberland filter. For convenience we shall subsequently refer to this solution as the “chloroformed solution.”



it was seen that the amœbæ did not appear to multiply, in fact they gradually died out. This invariably happens when their only food supply consists of dead bacteria killed by hydrochloric acid. It is interesting to note that encystment did not take place in the absence of injurious bacterial products. The amœbæ therefore have in fact been made to excyst by artificial means, *i.e.* by the chloroformed extract of bacteria, but they are unable to encyst again to avoid death by starvation, a fact which confirms our previous experiments. A similar result was obtained by incorporating the chloroformed solution in the jelly medium (1 cc. in 5 cc.), the mixing being done at 40° C. in order that the enzymes might be unaffected. The amœbæ excysted in three hours, lived precariously on the dead bodies of the bacteria, and then gradually died.

The chloroformed solution was then boiled, and found to be ineffective in hastening excystation either in solution or when mixed in a jelly.

The amœbæ excysting in the absence of living bacteria are all characterised by a transparent, faintly granular appearance; their karyosome is small, movement is sluggish, growth in size is slow, and multiplication appears to be absent. The food vacuoles under these conditions were almost entirely absent.

Suspecting the action of a ferment from the fact that boiled extract was of no use, we then tried pepsin (0.4 per cent.) and HCl (0.2 per cent.) in the jelly, and inadvertently boiled the pepsin to sterilise it. No excystation occurred. Unboiled pepsin was, however, effective, excystation taking

place fairly rapidly, and living amoebæ were fairly abundant all over the medium, but gradually died out in the course of a week. Nutrient agar subcultures of these amoebæ showed the conditions to be bacteriologically sterile in all the tubes except one, and in this the amoebæ encysted again in a few days. The effect of the pepsin was striking, as, although not all the cysts excysted, they all exhibited swelling of the ectoplasm, which is the first stage visible in the process, and many of the enclosed amoebæ were noticed moving within the cyst walls. This internal movement is comparable to the rotation found by Goodey to take place in the cysts of *Colpoda cucullus* during excystation.

*Cultures of amoeba with dead bacteria.*—Hitherto the difficulty had been to maintain the existence of those amoebæ which had been made to excyst. Bacteria killed by hydrochloric acid did not appear to be adequate food. No better results were obtained by using boiled bacteria, and recourse was had to other means. A luxurious growth of *Bacillus fluorescens liquefaciens* on nutrient agar was exposed to ether vapour at 37° C. for twenty-four hours, the ether being then evaporated off until the agar was free from odour. A jelly was prepared as follows: 2-per-cent. agar jelly 5 cc., chloroformed solution of dead *B. f. liq.* 3 cc., and creatine added to 0·5 per cent. ; total 8 cc. This was made into a slope, smeared thickly over with etherised bacteria, bacteria-free cysts placed on it, and the tube incubated at 37° C. Excystation took place as usual, but no obvious multiplication. A similar jelly was then made, but with the addition of 0·1-per-cent. choline, and on this medium rapid



multiplication took place, the amœbæ looked more natural, and divisions were watched. The culture was kept going for five days, when it was obvious that reproduction had ceased. The amœbæ did not, however, encyst at once, but persisted in their free condition for a fortnight (although many appeared to die from lack of food), when encystment took place, although no living bacteria were present in the tube. We think this may possibly be due to the fact that the choline becomes slowly oxidised to neurine, which is an intensely toxic substance. We should mention that, if there is any bacterial contamination of these preparations, its presence is shown by a visible extension of the bacteria from the part where the tube is inoculated to the edges, together with a cloudiness of the medium, and also by the fact that encystment always occurs rapidly when a tube becomes infected. As a further precaution, if there is any doubt about accidental infection, subcultures are made on nutrient agar.

We were at a loss to explain why the amœbæ had ceased to multiply except on the assumption that they were short of something, or that their own products of metabolism were injuring them. A subculture was therefore made on a jelly containing creatine and choline as before, but without the chloroformed solution, which had only been employed in the first case to get the amœbæ out of the cysts. Very little growth occurred and something still appeared to be lacking which was necessary for their continued reproduction. A second subculture was then made, this time with the addition of 1 cc. of the chloroformed extract, and

on this medium the amœbæ thrived and multiplied all over the tube. It is thus apparent from these experiments that the amœba requires, for its satisfactory cultivation without living bacteria, the presence of some soluble substances which are formed by bacteria and which are destroyed by boiling but not by chloroform (*vide infra*). Under natural conditions these substances are provided by the growth of the living bacteria. It was suggested by Liston that some products of living bacteria are essential for the continued reproduction of amœbæ, and we believe that these substances are of an extracellular nature and can be applied to the amœbæ in the form of an aqueous solution which contains the products of bacterial growth.

*Pure cultures of amœba.*—We are in some doubt as to what is generally understood by this expression. We have been able to grow amœbæ in the absence of living bacteria, and it appears to us that a definition of the term “pure culture” should be satisfied by these conditions. The dead bacteria, killed by boiling, which we have employed, have no more significance to us than if they were particles, regarded merely as dead food. At the same time the amœba does require more than this before it will multiply continuously, namely, some substances produced by bacteria which are destroyed by boiling, but not by chloroform. It also requires auxetics or kinetics (preferably both of these) to enable these substances (which appear to be of the nature of ferments) to act on the cell. If, however, by the term “pure culture” is meant one in which the amœba is able to multiply on a medium which has been boiled and contains no solid particles,

such as an ordinary nutrient agar jelly, our experience leads us to believe that this is not possible. It is our intention to make further investigations as to whether amœbæ can live on sterile liquid food, which has not been boiled, and, as a preliminary test, a few experiments have been carried out with normal sterile horse serum. This was selected for two reasons, viz., firstly, because it contains ferments, which, we thought, might be capable of causing excystation; and secondly, because it contains proteins in a soluble (colloidal) form, which might possibly be utilised as food by the amœbæ.

*The effect of tyrosin and choline on reproduction of amœbæ in pure culture.*—Six test-tubes were obtained, each containing 5 cc. of 2-per-cent. agar jelly. Each of these was then prepared in a particular way (*vide* Table II., p. 74), by adding an auxetic or a kinetic or both to the jelly, and the tubes were labelled A to F. These were then sterilised and sloped. Dead bacteria (*B. fluorescens liquefaciens*, which had been killed by boiling) were smeared over the surface of each of the slopes and a few drops of horse serum were placed on those labelled A—D. Cysts<sup>1</sup> (free from living bacteria) were then placed on each slope. The tubes were examined at intervals of every few hours to see if excystation had taken place, and they were subsequently inspected every day for a week to find out if there was any multiplication of those amœbæ which had escaped from the cysts. The results of these observations are tabulated under the respec-

<sup>1</sup> The cysts were selected from the cultures on choline jellies, in which encystment had occurred after a fortnight's growth in the absence of living bacteria.



tive headings of Excystation and Reproduction (series A). The latter results appeared to be of such importance that the experiment was repeated (with some slight modifications of technique) as follows :

An identical series of six test-tubes was made as before (*vide* Table II., A—F). Jelly films were made from each of these on microscope slides, which were then inverted, resting on corks, over water in Petri dishes, sterile precautions being taken throughout. Dead boiled bacteria were smeared on all the films, and a few drops of normal horse serum were placed on A to D, the films thus corresponding exactly to the slopes employed in the former experiment. On this occasion, however, living amœbæ (obtained from cultures which were free from living bacteria) were placed on each jelly film instead of cysts, and a cover-slip was dropped over each preparation. As already described in Chapter I., the cover-slip does not press on the amœbæ when the slide is in the inverted position which we have employed, and its use is advisable, since it enables the preparations to be more readily examined. The specimens were examined twice a day for several days and the degree of multiplication is tabulated under the heading Reproduction (series B).

It has thus been possible to reduce the food supply of the amœbæ to a uniform condition, namely dead bacteria and horse serum, and to show the influence of tyrosin in exciting reproduction (tube C) and its increased effect (tube D) when an augmentor (kinetic) such as choline is present.

At the end of a week, horse serum was smeared

## 74 ENCYSTMENT AND EXCYSTATION OF AMŒBA

on one of the tubes (E), in which no excystation had taken place, and the amœbæ excysted within twenty-four hours.

All the tubes were tested for sterility by means of agar slopes and gelatine stabs, and, as a further precaution, the slopes employed in the experiments contained one-third part of gelatin, which showed no signs of liquefaction.

TABLE II.—THE ACTION OF NORMAL HORSE SERUM IN CAUSING EXCYSTATION OF AMŒBA CYSTS, AND THE EFFECT OF AUXETICS AND KINETICS IN INDUCING REPRODUCTION OF AMŒBÆ

Tube	Dead boiled bacteria	Horse serum	0·1-per-cent. choline (kinetic)	0·1-per-cent. tyrosin (auxetic)	Excystation	Reproduction (Series A)	Reproduction (Series B)
A	yes	yes	no	no	yes	none	none
B	yes	yes	yes	no	yes	none	a little
C	yes	yes	no	yes	yes	some	some
D	yes	yes	yes	yes	yes	yes (very great)	marked
E	yes	no	yes	no	no	no free amœbæ	none
F	yes	no	no	yes	no	no free amœbæ	none

*Cultures of amœba on liquid food in the presence of auxetics and kinetics.*—The next steps were carried out without any dead bacteria as follows: To 5 cc. of sterile 2-per-cent. agar jelly in a test-



tube 0·1-per-cent. tyrosin and 0·1-per-cent. choline hydrochloride were added, and the surface smeared with sterile horse serum. Cysts with only a few accompanying dead bacteria were placed on this and allowed to grow for a week, when the living amœbæ were transferred to a second slope made in exactly the same way. This subculture was again removed after a week to a third similar slope and the amœbæ on examination were found to look fairly healthy, although rather pale and transparent. No bacteria, living or dead, could be distinguished and the cultures were sterile when tested in the usual way. On the third day the culture became contaminated, upon which the amœbæ rapidly encysted. Simultaneously with this experiment, a similar tube was prepared, but in this case the "chloroformed solution" already described was employed instead of horse serum, and although perhaps not quite so effective we were able to maintain the culture for about a fortnight. It is thus possible to grow amœbæ for a short time even in the absence of dead bacteria, but the growth is never so abundant as when living bacteria are present, and this could hardly be expected under the conditions of artificial feeding and induced reproduction to which they have been subjected.

#### SUMMARY AND CONCLUSIONS

*Excystation.*—Amœba cysts which have been freed from accompanying bacteria (living and dead), and from soluble bacterial products, do not produce free amœbæ when placed in pure water. Excystation will, however, take place in the presence either

of the dead bodies of bacteria or of certain soluble products of the growth of living bacteria.

These products are probably of the nature of ferments, as they are destroyed by boiling but not by chloroform.

The action of these substances is increased if an augmentor such as choline is present.

Unboiled pepsin solutions will produce excystation in a limited number of the cysts, while boiled solutions are ineffective. Normal horse serum contains substances which will cause excystation.

*Growth and reproduction.*—The food of an amœba under natural conditions consists of living bacteria. These can be replaced in artificial cultures by dead bacteria provided there are present in addition certain substances which are destroyed by boiling and which are probably of the nature of ferments.

Multiplication does not, however, take place unless an auxetic such as tyrosin or creatine is present, and we think this may act by enabling the ferment to influence the chromatin of the cell in some manner not yet understood.

The “augmenting” action of a kinetic may then be due to the activation of the process originated by the combined action of the auxetic and the ferment.

The results of the above experiments on amœbæ have prompted us to undertake an investigation into the action of ferments, in the presence of various combinations of auxetics and kinetics, on the reproduction of individual human and other cells.

### III

## THE PREPARATION OF "PURE MIXED CULTURES" OF AMŒBA

*Definition.*—By the term "pure mixed culture" of amœba is meant the cultivation together of a single species of amœba with a pure strain of a bacterium. This must be carefully distinguished from the expression "pure culture," which involves the cultivation of the amœba without any living bacteria at all.

*Introduction.*—In the course of our previous experiments we had always been faced with the difficulty that an organism requires food for its existence to be maintained, and that when testing the action of auxetics and kinetics in exciting reproduction through more than one generation the possible influence of substances produced by the breaking down of the food, which are themselves auxetics and kinetics, has had to be borne in mind. By reducing the nature of the food to a uniform condition we hoped to be able to compare the rate of growth in cases where auxetics and kinetics were deliberately added with those in which these substances were absent. The object, then, of the preparation of "pure mixed cultures" was to eliminate from the environment of the amœbæ the

complex mixture of chemical substances produced by the accompanying growth of a large variety of different bacteria in the same culture, and subsequently to isolate the amœbæ or their cysts from the presence of all other living organisms.

At the outset we were aware of the difficult nature of the task from reference to the extensive literature on the subject. Many observers are stated to have obtained pure mixed cultures by various means, but so far as we are aware the result has not always been verified by a bacteriological analysis, and in our opinion no culture could be accepted as pure without this precautionary measure. The preparation of a pure mixed culture involves two distinct processes, viz. (1) the separation from its fellows of a single individual amœba, and (2) its subsequent cultivation with a pure strain of a bacterium. The former is a simple matter and can be carried out in ten minutes; the latter is most difficult and has occupied our attention for four months. The two stages will be described separately.

#### 1. THE SEPARATION FROM ITS FELLOWS OF A SINGLE AMŒBA CYST OR LIVING AMŒBA

We have found it possible to pick off a single amœba cyst from a culture by means of a fine capillary tube, and to place it on the surface of a sterile agar plate. This has been done on three occasions, but only on one of them was the amœba cyst free from all bacteria. At other times, although apparently only one cyst was drawn into the tube, it could not be recovered, probably



through adhering firmly to the glass. The manipulation of a single cyst in this way is most laborious and uncertain, and in view of the fact that there is a better method the net result is simply a waste of time. The alternative method we have employed is as follows :

Take a glass capillary tube about 12 cm. long and 1 mm. diameter. Flame the centre and draw out quickly to the fineness of a hair. Break into two equal portions, and reduce each of these to a length of 6 cm., so that you have two short tubes each consisting of a wider part and a very fine portion. Now select a culture rich in cysts and moisten with a drop of water, scraping gently, so as to loosen the cysts from the jelly surface. Allow a minute portion of the liquid to run into the fine end of the capillary tube, and then run water into the tube until about 1 cm. of the broad end is filled. Mix up the contents of the tube by vigorous rotation. Next prepare a small 2-per-cent. agar jelly film on a microscope slide, and focus the upper surface with a low-power objective. Tap out on to blotting-paper some of the liquid in the capillary tube, and then, while looking through the microscope, gently touch the film with the fine end of the tube. A small volume of the suspension of cysts will run on to the jelly and will spread out in an area which is distinctly visible, and which occupies only a small portion of the field. If no cyst is present or if there are more than one, place another small drop on a fresh film and repeat this until you have placed one cyst only on the jelly film. If the suspension is too rich in cysts, dilute it until a



suitable concentration is obtained. This method is quite simple, and with a little practice one can make half a dozen cultures (each from a single cyst) within an hour. The cysts are easily recognised with a low power, and to make sure that only one is present the whole field can be traversed with a high power. In the same way individual living amœbæ can be planted out, but are not always distinguishable from débris, etc., and one might overlook the presence of a very small form. We have also by this means isolated various flagellates, fungi, etc., from other organisms which might lead to confusion in impure cultures. The necessity for separating a single amœba was made still more evident to us by the appearance, in some of the cultures, of an organism (fig. 25) which was at first mistaken for the amœba, and which gave us considerable trouble for some time until it was removed. When showing this method to others we have taken the opportunity to make repeated subcultures from the progeny of a single cyst, so that the risk of contamination by other amœbæ is reduced to a minimum.

But although these methods enable single amœbæ or cysts to be separated from their fellows, they do not supply us with the individuals free from bacteria.

## 2. PREPARATION OF AMŒBÆ WITH PURE BACTERIAL STRAINS

*Preliminary Remarks.*—An impure culture of amœba will as a rule be found to contain bacteria

of various kinds—yeasts, fungi, possibly flagellates (such as Bodos), paramecia, and other ciliates, and any of the numerous organisms which may infect ordinary tap water, or which float about in the dust of a room. There is little trouble, by selecting suitable areas of a culture, in freeing amoeba cysts from everything but bacteria, although small moulds and minute flagellates will persistently appear in cultures which are not made with strict sterile precautions. A point of the greatest importance is the necessity for the removal of spore-bearing bacteria, which were constantly present in every culture we examined, and which have proved to be by far the greatest difficulty we have had to contend with. We know of no germicide which will certainly destroy spores without killing amoeba cysts, and the separation must be carried out entirely by mechanical means. After many failures, through the employment of methods which have already been described, we undertook the preparation independently by two different methods, one of which has been successful and the other partially so.

METHOD 1.—RESULT: PURE MIXED CULTURES OF AMOEBA WITH *B. fluorescens non-liquefaciens* AND WITH *B. brunneum*

Beginning with the most impure culture we could obtain, several subcultures were made on 2-per-cent. agar jelly in small Petri dishes inverted over water. By this method of cultivation a more rapid development of the amoeba is

obtained, and they wander from the site of inoculation to a much greater extent than in Petri-dish cultures kept upright to which only a little water has been added. After several days' growth, areas were selected in which the amœbæ (which had by this time encysted) looked as free as possible from bacteria, etc., and subcultures were made. Selected loopfuls were again taken, this time with the object of avoiding springing bacteria, which can occasionally be recognised by their forming long filaments. Subcultures with strictly aseptic precautions were then made, and single cysts isolated on to sterile plates by the method recently described. In this way one is able to obtain cultures with a limited variety of bacteria with the probability of having eliminated springing forms. To determine this in a particular culture an abundant scraping was taken from all parts of the surface and heated at 80° C. for a quarter of an hour. No growth occurred on inoculation of nutrient agar slopes at room temperature and 37° C., and no spores were visible in stained films made from the mixture.

There now only remained to select a method of removing the few remaining bacteria without killing the cysts, and for this purpose formalin was chosen, as we had previously found that a culture could be exposed even to a 3-per-cent. solution for a week and living cysts could be recovered. Petri-plate cultures were therefore covered with formalin for forty-eight hours, washed thoroughly with sterile water, and loopfuls tested on sterile nutrient agar slopes. They were then found to be free from living bacteria. Cysts thus



treated by formalin were then placed with a small quantity of a pure culture of *B. fluorescens liq.* (which had been isolated from the tap water) on a sterile 2-per-cent. agar slope, and, after a few days, amœbæ had escaped from the cysts and were actively multiplying. This might reasonably have been regarded as a "pure mixed culture," as the bacteria in fixed films looked morphologically pure, but to remove any doubt the culture was plated out both by pouring and spreading, and to our surprise three types of colony appeared. Petri-dish cultures were therefore made to see if a loopful of cysts could be picked off with one of these types alone, but the subsequent analysis showed that only one of them had been eliminated, namely *B. flavo coriaceus*. This bacillus grows very slowly, forming minute pin-head colonies, which may easily be overlooked. Recourse was again had to formalin, but this time no cysts could be recovered which would grow when placed with pure cultures of different bacteria. Even if only washed with the formalin for half an hour, and the reagent removed with repeated washings, no cultures could be obtained. The uncertainty with formalin is due to the fact that it is impossible to say whether you have killed the cysts or merely rendered them so resistant that the bacterial products which cause excystation are unable to produce this effect, and if excystation is delayed too long it will not occur at all.

Mercuric chloride was then tried in various strengths (0.005 to 1 per cent.), and from one plate cysts were placed in culture with *B. f. liq.*, but again the supposed pure culture consisted of the

two bacteria present in the treated plates. Benzoic acid, quinine sulphate, strychnine hydrochloride, caustic soda, hydrochloric acid, heat, and drying were then employed on slopes, plates, and suspensions of the cysts in water. Of these substances only hydrochloric acid and the action of drying were successful (but the former is the best for practical purposes), and it is only necessary to state here that cysts were readily freed from the two particular bacteria mentioned above by exposure to 2-per-cent. HCl for forty-eight hours. The culture made from these was found to be bacteriologically pure with *Bacillus fluorescens non-liquefaciens* (fig. 26). The strongest evidence we are able to submit of having obtained pure mixed cultures of amœba is that the above mixture of two bacteria rapidly liquefies a gelatin medium, whereas the cysts after treatment with the HCl, when mixed with a pure strain of a non-liquefying bacillus on a 12-per-cent. gelatin slope, develop into living amœbæ and encyst again, there being no liquefaction of the gelatin at the end of a fortnight's growth. When once one has obtained a pure mixed culture with a particular bacillus reliance must be placed on facts known to bacteriology as regards the kind and quantity of germicide to employ, as it is obviously impossible to make a complete analysis of cultures with every bacterium with which you place the cysts.

If, for example, one obtains a culture with *Bacillus fluorescens liquefaciens*, which is readily destroyed by HCl, this can be used as a routine method and an indefinite number of pure mixed cultures made from it. This is the method we at



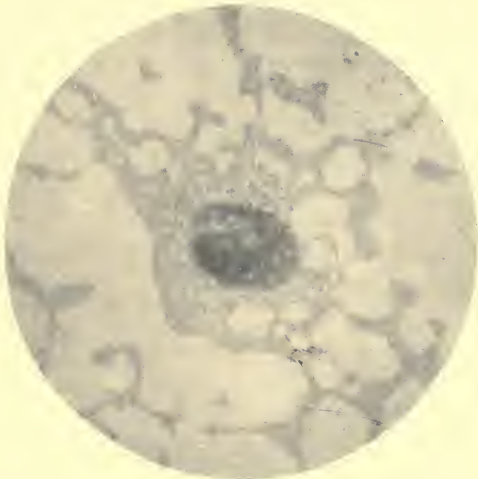

FIG. 26.—Photomicrograph of amoeba in "pure mixed culture" with *Bacillus fluorescens non-liquefaciens*.

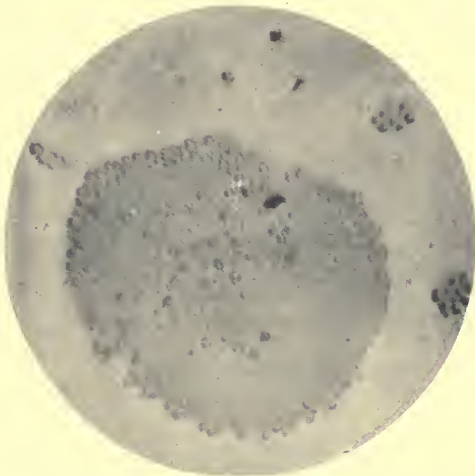

FIG. 27.—Photomicrograph of amoeba cysts adhering to a colony of bacteria.



present adopt whenever a culture with a different bacillus is required or when cysts are wanted free from all bacteria. The acid apparently does very little harm to the cysts, as excystation of treated cysts is not noticeably slower than in untreated ones. The acid can be washed away with sterile water, but except for special purposes the dilution in a fresh medium is sufficient, as amœbæ will excyst in an acid medium.

**METHOD 2.—RESULT: CULTURE OF AMŒBA (INFECTED WITH A PARASITE) WITH TWO BACILLI**

This method was adopted as a possible means of preparing pure mixed cultures when our experience with germicides seemed so little hopeful. It depends entirely on the mechanical isolation of cysts with a particular bacillus by a succession of platings out in colonies, sterile precautions being taken throughout and no chemical agent being employed. As in Method 1, a most impure culture was used in order to see if this plan would be available under the most adverse circumstances. One cyst was easily placed on a sterile jelly with a few bacteria only, as described in the beginning of this chapter, and a culture rich in cysts obtained. Areas distant from the site of inoculation were scraped, and the cysts and bacteria so removed were washed many times in a beaker with large volumes of water. The cysts fall to the bottom more rapidly than the bacteria, and repeated washings reduce the relative number of the bacteria considerably. This is necessary, as one must deal with a large number of cysts, and how-

ever carefully they may be picked off from a plate, the excessive number of bacteria present does not allow of plating out colonies sufficiently far apart to enable a single colony of bacteria to be picked off along with adherent cysts. The washing requires care, the upper layers being siphoned off, leaving most of the cysts at the bottom of the vessel. The washed cysts are centrifugalised, Petri-dish cultures made, and after a few days colonies are found with abundant cysts either on them or more often collected round their edges. One suitable colony was picked off with a platinum loop, cultures prepared as before, and the whole process of washing and plating out repeated. Finally an agar slope culture was submitted to analysis, and found to be almost pure *B. f. liq.* with a slight admixture of *B. proteus vulgaris*. In the preparation of this slope for analysis it was observed that the amœbæ were in the free-living condition, and, while the analysis was in progress, they were expected to encyst, but they did not do so,<sup>1</sup> although every effort was made to bring this about. It was clear that no useful object would be attained if the separation was continued, because a pure mixed culture of amœbæ which do not encyst is of no value in the preparation of cultures with other bacteria.

However, the method is shown to be a practicable one, as spores had been eliminated; the two bacteria present are easily killed; and the culture was almost pure. In connection with this plating-out method, two points must be borne in mind: Under the comparatively dry conditions in which

<sup>1</sup> Because of the presence of an amœba parasite.

it is only possible to obtain scattered colonies, amœbæ do not multiply rapidly enough to make the method of any use; and, on the other hand, the addition of water tends to make the colonies coalesce. On this account, it is necessary to plate out several times instead of only once or twice. The second point is that amœbæ avoid the actual colonies of bacteria, and the cysts are most abundant round their edges and in between them (fig. 27). This method was only partially successful, but it shows that amœbæ can be separated by it without resorting to germicides.

After these experiences, we give the following suggestions as to the steps which might be taken by others in the preparation of pure mixed cultures of amœbæ, because we think the principles would be useful in the case of other organisms which form resistant cysts, and much time would be saved if the experimenter had some information to guide him in the subject. No definite plan can be laid down as a hard-and-fast rule for every case, and discretion may be used as to the order of proceeding, and as to what stages may be omitted, viz. :

Separate a single cyst by the method of placing it on a jelly, as described at the beginning of the chapter. Do not waste time in trying to pick one off the culture, but be careful to place only one cyst on to the jelly. Eliminate spore-forming bacteria by selecting areas from cultures as free as possible from all bacteria, especially from those which grow into long filaments.

Before using germicides, test for the absence of spores. At this stage, treat the cultures with a germicide such as 2-per-cent. HCl for two or three



days, and, if all bacteria are killed, wash away the acid, and plant the cysts under sterile precautions with a pure culture of the particular bacillus you select.

If any difficulty occurs at this point, an analysis may be necessary to determine what bacteria have escaped the action of the germicide, so that by plating out it may be removed. To decide if the culture is pure, treat amœba cysts in culture with a gelatin-liquefying bacillus with the germicide, and transfer to a pure culture of a non-liquefying organism.

*Some Notes on Various Means employed by Other Authors and Ourselves in the Separation of Amœbæ or their Cysts from Accompanying Bacteria in the Preparation of Pure Mixed Cultures.*

A. MECHANICAL MEANS

(1) "*Picking off*" a single cyst.—It is possible to accomplish this free from all living bacteria, but its success is largely dependent on good fortune, and pure cultures made in this way should be carefully examined. One cannot say that, because a cyst looks free from bacteria, it really is so; as we have many times examined such cysts by the jelly method of staining, and found bacteria, which were invisible when unstained, closely adhering to the edges and to the surface of the cyst.

The difficulty in separating a single cyst by picking it off is due to the fact that, if the jelly surface is dry, the cyst is firmly adherent (in old cultures almost imbedded), and will not enter the

tube, while, if the surface is wet, the introduction of the tube sets up a disturbance which is likely to attract bacteria from a distance as the tube is withdrawn. The most practical plan is to use a dry jelly, and touch the neighbourhood of the cyst with the fine, wet end of the tube, and then move it about gently. If the far end of the tube is then lowered sufficiently, the cyst may rush in by the action of gravity, the whole proceeding being carried out under a low power of the microscope. This principle is of use in the separation of cysts from moulds, flagellates, etc., or for removing a clump of cysts as the first stage in the purification of cultures, but may be simplified, as it is only necessary to touch the jelly surface with the fine, wet point of a glass tube, when many cysts will adhere, and can be transferred to a fresh medium. We have failed to isolate cysts with bristles coated with vaseline, etc., and we have had no experience with the Barber pipette. We have not been able to pick off a single free living amoeba and recover it from the tube into which it was drawn.

(2) *Methods depending on migration of amoebæ from the site of inoculation.*—In some cultures where the amount of water present is limited, amoebæ may wander away apparently free from all bacteria; but we have not succeeded in removing them without contamination, although thin slices have been taken off the jelly and portions have been cut out with a tube attached to the objective. A method has been described, based on this principle, in which a series of walls consisting of a pure strain of bacteria were drawn around the site of inoculation, so that wandering amoebæ

might pass through them and leave the mass of mixed bacteria behind. On one occasion an amœba was found beyond the second wall, but it could not be recovered. When the amœbæ reached the first wall, they either encysted or degenerated, and formed a solid-looking mass. Having noticed that amœbæ crawl along the hyphæ of moulds growing in the medium, fine hairs and glass tubes were set radiating from the centre, but water collects round them and there are more bacteria there than at other parts. With fine radiating grooves in the jelly no particular advantage could be seen. Lastly, amœbæ are said to have been isolated by the principle of geotropism, and by electrical methods (Mouton).

(3) *Heat*.—The possibility of this means being useful to destroy bacteria without injuring the cysts was suggested by a reference to an article by Musgrave and Clegg, in which the method was mentioned as worthy of a trial. This appealed to us, as we thought that by employing some method of intermittent sterilisation at say 65° C. it might be possible to remove even sporing bacteria. Old cysts were used, as they were expected to be more resistant than young ones. A number of cultures were exposed respectively to temperatures ranging from 60° C. to 80° C. for half an hour on four consecutive days. No amœbæ could be recovered from any of the cysts, the contents of which in fact looked disorganised. We have, since this, more accurately determined the thermal death-point of amœbæ cysts, and find that, although some will stand 58° C. for half an hour, none of them will live at 60° C. As most water bacteria require at least 55° C. to destroy them, we think that the



margin is too small to render this method of any service in isolating cysts from a mixture of bacteria.

(4) *Drying*.—As a preliminary test cysts in an impure culture were smeared over the inside of test-tubes which were plugged with wool and placed in a closed vessel over concentrated sulphuric acid. After three weeks cultures were made, and excystation readily occurred with two varieties of sporing bacteria which had withstood the action of the drying; all non-sporing forms being apparently killed. A series of similar tubes of cysts with *B. f. liq.* and *B. brunneum* have since this been desiccated over phosphoric pentoxide for six weeks, and on examination all the bacteria have been found to be killed, and, although a few of the cysts look degenerate, the majority appear quite normal and a pure mixed culture was made from them with *B. subtilis*. If cysts are dried with pure strains of bacteria, which are known to be destroyed in this way, one can obtain a stock of cysts free from all living bacteria, which are not open to the objection that the use of a germicide might injure the cysts and so interfere with experiments carried out with them. But, as remarked above, the HCl method is more practicable.

## B. CHEMICAL METHODS: THE USE OF GERMICIDES

(1) *Formalin*.—The employment of this substance has given us considerable trouble and we are not yet sure of its action on the amœba cyst itself. Cultures of old cysts have been exposed to its action both in solutions and on jelly media in 1-per-

cent. to 3-per-cent. solution and as vapour, the time having been varied from simple washing to a period of a week. On only a few occasions have cysts been recovered which would excyst after the formalin has been washed away. As living bacteria have also been got from the surface of culture media, exposed to 2-per-cent. formalin for a week, we are inclined to think that those cysts which escape have not been exposed to the full effect of the chemical. There is thus the danger of examining pure mixed cultures of amœba made in this way and finding them morphologically pure, whereas they may be contaminated with the few bacteria carried over with the unaffected cysts. It is interesting to note that the cysts do not look abnormal (*e.g.* as under the influence of heat), and it is impossible to say whether they are alive or dead, and whether their subsequent failure to develop is due to coagulation of the ectocyst which will protect the contents, or to death.

(2) *Mercuric Chloride*.—This substance was employed because, having a high molecular weight, it might be possible to kill the bacteria with it before it diffused through the dense cyst walls and destroyed the enclosed amœba. On one occasion only were living cysts recovered after this treatment, but the culture made from them was impure on plating out colonies. The same remarks apply here as in the case of formalin, and we should not use either of these again in the preparation of pure cultures. It appears as if strong solutions of germicides which coagulate albumen rapidly cannot be relied on to destroy all bacteria on the surface of a culture medium.



(3) *Hydrochloric Acid* (2 per cent. of B.P. pure 31·8-per-cent. HCl).—As described before, this is the most useful germicide for separating amœba cysts from living bacteria provided that the bacteria are found by actual experiment to be killed by it. It has been of no use when applied directly to impure cultures in which the nature of the bacteria was unknown. We first employed it on a culture of *B. f. liq.* and *B. brunneum*, both of which were totally destroyed on jelly media, and in solution by 2-per-cent. HCl in twenty-four hours. The acid was originally washed away eight times with sterile water, but this is unnecessary, for amœbæ will excyst on media containing at least 0·2 per cent. HCl.

(4) Among numerous other substances employed by different authors we need only mention alkalis, to which there seems to be no objection, as cysts will stand exposure to 5-per-cent. caustic soda for at least a week. Sodium bicarbonate has been used, and if spores are absent we think it might be adequate.

#### SUMMARY

By means of various mechanical devices and the use of germicides, cultures of amœbæ with a limited variety of bacteria were obtained, and these, when subjected to the action of 2-per-cent. hydrochloric acid for twenty-four hours, or to thorough drying for six weeks, were found to be free from living bacteria, while the cysts were still alive and have been employed in making pure mixed cultures, the results being tabulated briefly as follows :



94 "PURE MIXED CULTURES" OF AMŒBA

NAME OF BACTERIUM	REMARKS
<i>B. fluorescens liquefaciens</i> .	{ Excystation rapid. Growth profuse.
<i>B. fluorescens non-liquefaciens</i> .	{ Excystation fairly rapid. Good growth.
<i>B. prodigiosus</i> . . . .	} Good growth.
<i>B. megatherium</i> . . . .	
<i>B. subtilis</i> . . . .	
<i>B. flavo coriaceus</i> . . . .	{ Excystation slow. Good growth.
<i>B. brunneum</i> . . . .	{ Fair growth. Encyst rapidly.
<i>B. proteus vulgaris</i> . . . .	} Excystation fairly rapid. Growth not good. Amœbæ encyst soon.
<i>B. coli</i> . . . .	
<i>Möeller's mist. B.</i> . . . .	} Acid-fast non-liqu- efying bacteria. Excystation very slow and growth of amœbæ poor even on nutrient agar media.
<i>B. rabinowitch</i> . . . .	
<i>B. nabaro 3</i> . . . .	
<i>B. nabaro 5</i> . . . .	
<i>B. Timothy grass</i> . . . .	
<i>B. pyocyaneus</i> . . . .	{ Good growth, but encyst soon.
<i>B. diphtheriæ</i> . . . .	} Not suitable.
<i>Pneumococcus</i> . . . .	} Excystation readily, but en- cystment is slow as the cocci rapidly die.
<i>S. pyogenes albus</i> . . . .	

NAME OF BACTERIUM	REMARKS
Amœba parasite . . . . .	<span style="font-size: 3em; vertical-align: middle;">{</span> <span style="display: inline-block; vertical-align: middle;"> <b>E</b>xystation                      occurs, but the                      amœbæ rapidly                      degenerate.                 </span>

From a general survey of these results we find that the most suitable bacteria with which to cultivate amœbæ are those that naturally occur in water. The pathogenic bacteria, and those which produce toxic substances (*e.g.* neurine) and foul gases, such as *B. coli*, *B. brunneum*, etc., are not good, for, although cultures can be obtained with them, the amœbæ do not thrive and encyst before much multiplication takes place.

It should be mentioned that spirilla-like bodies often appear in pure cultures with motile bacteria, particularly *B. f. liquefaciens*. They are motionless and often show knobbed or frayed-out ends, and are probably the cast-off flagellæ of the bacilli as described by Gauducheau.

### APPENDIX

#### BACTERIOLOGICAL ANALYSES DURING THE PREPARATION OF "PURE MIXED CULTURES" OF AMŒBA.

THESE were undertaken at a stage when cysts had been obtained in apparently pure culture after treatment of an impure culture with 2-per-cent. formalin for a week. *Bacillus fluorescens liquefaciens* had already been isolated, and the formalised cysts were mixed with some of these, and the

resulting culture plated out. Three types of colonies were obtained, and from each of these nutrient agar slope cultures were prepared, and an analysis of each of these was carried out. The three bacteria isolated in this way were *B. fluorescens liquefaciens*, *B. brunneum*, and *B. flavo coriaceus* (fig. 28). The colonies of the liquefying fluorescens were not recognised as different from those of the non-liquefying variety. The last of these bacteria is very slow-growing on plain 2-per-cent. agar at the room temperature, and in subcultures was quickly crowded out by the other two. These were difficult to get rid of until hydrochloric acid was tried. Slope cultures treated with this reagent (2 per cent.) for forty-eight hours, and thoroughly washed, were found sterile to nutrient agar slopes at the room temperature and 37° C. The cysts were put into pure culture with *B. fluorescens liquefaciens*, cultures of this being treated again with HCl, and the cysts transferred to a culture of the non-liquefying variety on a gelatin medium.

The second series of analyses was carried out on a supposed pure mixed culture prepared by the plating-out method, and showed the presence of two bacteria, namely, *B. fluorescens liquefaciens* (fig. 29) and *B. proteus vulgaris* (fig. 30). The necessity for a complete analysis is indicated by the fact that the differentiation of these was only finally made out by means of a nutrient broth culture, for although two types of colonies appeared on the plates, their morphology and reactions were very similar. The full report is subjoined :

Plates were prepared by pouring, and two types of colony were obtained, A and B, viz. :



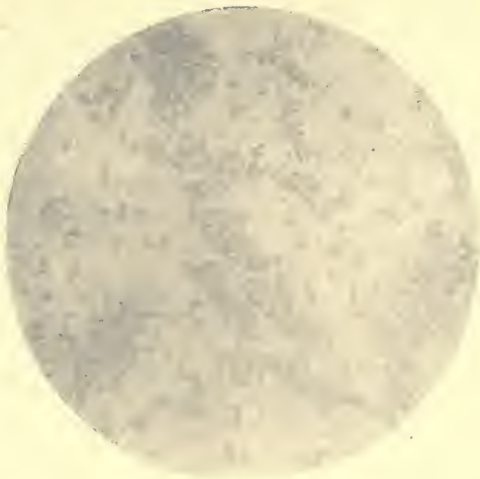

FIG. 28.—Photomicrograph of a pure culture of *Bacillus flavo coriaceus* which was isolated from an *impure* culture of the amoeba.



FIG. 29.—Photomicrograph of a pure culture of *Bacillus fluorescens liquefaciens* which was isolated from the amoeba cultures.





(A) Round colonies, edges entire and oleaginous. Surface flat, central portion finely granular.

(B) Round colonies, edges oleaginous and undulate. Surface effused, form amœboid. Colonies show a central growth, brownish in colour, with feathery processes extending into a very clear border. These later developed amœboid processes which grew rapidly, and sometimes became detached from the parent colony. Cultures were made from each type, and stained films showed bacilli somewhat similar in appearance. As type B colonies were very scanty and crowded in by type A, it was considered advisable to prepare a further plate from a small portion of the first one. Two types of colonies were again obtained (C and D), which were obviously reproductions of A and B. As the types were very well separated on this plate, slope cultures were made from them, and analysed (*vide* chart). On the fourth day a third type appeared on the plate similar to A, but darker in colour and smaller. A slope culture of this was taken (E) and found to be identical with A, E being only a deep-seated A type.

In addition to the above principal analyses, several other bacteria have been separated from the impure cultures, viz. :

*B. prodigiosus*, three sporing bacilli, namely, *B. megatherium*, bacillus of malignant œdema, and a third, a variety of the anthrax group but not yet identified with certainty (possibly *B. mesentericus vulgatus*). The amœba parasite has been obtained in pure culture, and its description will be found in the chart. Later still, a fourth bacillus with a terminal spore, whose identity is not known, was isolated.

A. BACTERIOLOGICAL ANALYSES. THREE BACILLI IN CULTURE WITH AMCEBA

Description .	Small bacilli, usually in pairs about 1.5 to 2 $\mu$ in length	Very small round-ended bacilli in pairs. Often very like diplococci	An extremely minute bacillus difficult to distinguish from cocci. Usually arranged in masses
Motility .	Very actively motile, flagellated	Actively motile	Non-motile
Thermal death-point	Near 58° C.	Between 53° and 60° C.	Between 58° and 60° C.
Ærobe or anaerobe	Facultative anaerobe	Facultative anaerobe	Facultative anaerobe
Staining reactions	C.M.B. } very well A.G.V. } C.F. }	C.M.B. } very well A.G.V. } C.F. } Safranin poor	C.M.B. fairly well, rather faint A.G.V. fairly well C.F. well
Gram . . .	Negative	Negative	Negative
Pleomorphism .	Some longer forms, especially in old broth cultures	None observed	None observed
Agar stroke 37° C.	Raised, moist, yellowish-white growth, very rapid. Agar develops a bright fluorescent green colour	Thick, raised, moist growth, light brown in colour, spreads over surface. Foul odour	Vigorous, raised, shining lemon-yellow growth. Does not spread very much.
Gelatin stab 20° C.	Spreads over surface and good growth in needle track. Fluorescent green colour diffuses into medium. No liquefaction	Liquefaction in wide funnel. Turbid and masses of growth at bottom	Greyish growth all along line. No gas and slow liquefaction. Does not spread on surface
Broth 37° C. .	Universal turbidity	Clear. Turbid at bottom and deposit on sides	Clear. Deposit on sides and at bottom
Colonies . .	Circular, edges well defined and lighter in colour than central portion. Colour creamy yellow, finely granular	Yellowish circular pin-head. Colonies raised and smooth. Edges sharply defined	Pin-head, circular, convex. Colonies brownish yellow. Edges sharply defined
Remarks . .	Forms no spores	Forms no spores	Forms no spores
Name . . .	<i>B. fluorescens non-liquefaciens</i>	<i>B. brunneum</i>	<i>B. flavo cortaceus</i>

## B. BACTERIOLOGICAL ANALYSES. TWO BACILLI IN CULTURE WITH AMŒBA

Description . . . . .	Short, round-ended, oval, plump bacilli, usually in pairs	Bacilli round-ended, sometimes in pairs
Motility . . . . .	Very actively motile	Very actively motile
Thermal death-point . . . . .	Very near 56° C.	Between 55° C. and 58° C.
Ærobie or anaerobe . . . . .	Facultative anaerobe	Facultative anaerobe
Staining reactions . . . . .	C.M.B. } well A.G.V. } C.F. }	C.M.B. } well A.G.V. } C.F. }
Gram . . . . .	Negative	Negative
Pleomorphism . . . . .	None in young 48-hour cultures, a few longer forms in old ones, especially broth	Very little in 24-hour old cultures. Longer forms after some days. Long forms common in broth cultures
Agar stroke 37° C. . . . .	Profuse, moist, yellowish-white, raised growth. Very rapid. Agar develops a green fluorescence	Raised, very moist, profuse growth, spreads over entire surface
Gelatin stab 20° C. . . . .	Rapid liquefaction of medium in wide funnel and formation of a slight green fluorescence	Rapid liquefaction in wide funnel
Broth 37° C. . . . .	Universal turbidity, no scum on surface	Scum on surface and universal turbidity
Colonies . . . . .	Circular raised white colonies Edges well defined and lighter in colour than central portion, edges very transparent	Very irregular, showing amœboid processes not so dense as B.F.L., whitish in colour, edges sinuous and very transparent
Remarks . . . . .	Forms no spores	Long forms found in broth cultures Forms no spores
Name . . . . .	<i>B. fluorescens liquefaciens</i>	<i>B. proteus vulgaris</i>



## C.—BACTERIOLOGICAL ANALYSES. THREE BACILLI ISOLATED FROM IMPURE CULTURES

Description . . . . .	A very minute bacillus, almost like a coccus	A large motile bacillus 6 to 10 $\mu$ in length	A slender, round-ended bacillus. About 4 to 6 $\mu$ in length
Motility . . . . .	Non-motile	Actively motile	Non-motile
Thermal death-point	Not determined	Not determined	Not determined
Ærobe or anaerobe	Facultative anaerobe	Facultative anaerobe	Anaerobe, but a certain amount of growth takes place aerobically
Staining reactions	C.M.B. well A.G.V. well C.F. well	C.M.B. well A.G.V. well C.F. well	C.M.B. well A.G.V. well C.F. well
Gram . . . . .	Negative	Positive ; stains very well	Positive, but does not stain well by this method
Pleomorphism . . . . .	Practically none seen	Shows long filaments, especially in broth	Shows some longer forms
Agar stroke 37° C.	Moist confluent growth, very pale pinkish white in colour. Blood-red growth when grown at 20° C.	Raised, moist, confluent growth	Greyish-white growth ; thin and moist ; dies off very soon
Gelatin stab 20° C.	Good growth, gelatin rapidly liquefied	Small funnel formed at top of stab. Gelatin liquefied rather rapidly in a medium-sized funnel	No surface growth, but slow growth in deeper part of needle track ; no gas and no liquefaction
Broth 37° C.	Turbid, good growth, no pigment	Universal turbidity ; many long bacilli	No growth observed under aerobic conditions
Colonies . . . . .	Small, circular, pink-white colonies, later blood red	Circular, greyish-white, rapidly liquefying colonies	Not observed
Remarks . . . . .	Brilliant blood-red growth on potato. Bacilli themselves are colourless. No spores	Forms spores. Shape oval, usually at end of bacillus, but not absolutely terminal.	Grows very well in deep glucose agar stabs at 37° C. Forms oval spores, usually in centre of bacillus
Name . . . . .	<i>B. prodigiosus</i>	<i>B. megatherium</i>	Not identified



D. BACTERIOLOGICAL ANALYSIS. *BACILLUS* WITH TERMINAL SPORES

Description . . .	Large round-ended bacilli about 3 to 8 $\mu$ in length and 0.5 to 0.8 $\mu$ in breadth. Arranged singly and in masses. Bacilli generally slightly curved
Motility . . .	Non-motile
Thermal death-point	Bacilli without spores near 60° C. for 10 minutes Spores stand 80° C. for half an hour, and 100° C. for 5 minutes
Ærobe or anærobe .	Facultative anærobe.
Staining reactions .	C.M.B. fairly well C.F. very well A.G.V. well
Gram . . .	Negative
Pleomorphism . .	None in young 24-48-hour cultures. Some longer forms in old cultures and also in broth
Agar stroke 37° C. .	Thin, moist, greyish growth, not very vigorous Growth often has a tendency to show numbers of isolated colonies like dewdrops
Gelatin stab 20 C.° .	Surface growth does not spread much No gas and no liquefaction
Broth 37° C. . .	Clear. No scum. Slight deposit on sides and at bottom
Colonies . . .	Edges entire and oleaginous Colonies at first resemble minute dewdrops
Remarks . . .	Forms large, oval, absolutely terminal spores which give the bacilli a drumstick appearance. Glucose agar stab 37° C. Good growth, no gas
Name . . .	Unknown

## IV

### A PARASITE OF AMŒBA

WHILE examining some amœba cultures, one of us (A.H.D.), noticed a peculiar black-looking, diamond-shaped body with a central dot (fig. 31), moving sluggishly about in the endoplasm of one of the amœbæ. Similar bodies, usually round and often in pairs, were found in other amœbæ from the same culture, and a single one was occasionally seen dividing and separating into two. These bodies were rather scanty, and could not be recognised with certainty in the medium outside the amœba. Subcultures of amœbæ which contained these bodies did not thrive on 2-per-cent. agar as they usually do, many in fact dying out completely, and others degenerating, becoming sluggish, highly vacuolated, and the contractile vacuole motionless (fig. 32). Many of the food vacuoles were enormously distended, and contained large numbers of granular bodies which were in a state of violent agitation. The outstanding feature, however, was the absence of any attempt of the amœbæ to encyst, in spite of the fact that they were being destroyed wholesale. The persistence of this morbid condition in every culture interfered with our experimental progress



FIG. 30.—Photomicrograph of *Bacillus proteus vulgaris*.

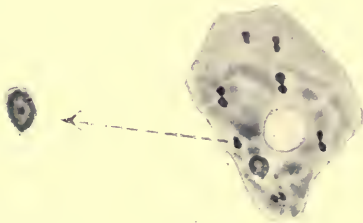

FIG. 31.—A parasite of the amoeba.



to such an extent that the whole stock was purposely destroyed, and everything sterilised, the experiments being continued with a fresh culture. No trouble of this nature recurred for some months, until one of us (J.W.C.), while preparing pure mixed cultures, selected an area from a plate consisting of free amoebæ and a few bacteria; the subcultures from this did not appear to be doing well, and on examination the same unusual-looking bodies were found as before. Efforts were made by diluting the cultures with water to get the amoebæ to encyst, so that the parasite could be destroyed with some germicide, but this measure had the opposite effect and all the amoebæ were killed. Eventually the almost pure culture which we were so near obtaining had to be discarded.

In a large number of cultures of amoeba infected with this body we had not hitherto seen a single cyst, but it has been found recently that encystment may occur after several weeks. By this time the parasite has also ceased to grow, and those amoebæ which have so far escaped are able to recover, and subsequently to multiply and encyst. On transferring such cysts to a fresh medium, the amoebæ which escape, however, do not look quite normal. In most of them the nucleus has broken up into chromidia, and it is a most striking fact that they now very frequently multiply by budding into as many as a dozen small amoebulæ, the dividing amoebæ exhibiting a rosette-like appearance which is quite characteristic.

The "bodies" under consideration were not easy



to demonstrate, as they could not be stained within the amœbæ sufficiently well to differentiate them from broken-down bacteria, etc., and we have found that the parasite itself readily breaks up into granules and rapidly loses its stain. Although we were able to infect healthy cultures with a loopful of material from an infected tube, the evidence for the existence of a parasite was not yet conclusive. Fortunately while examining some films containing infected amœbæ by the jelly method, a zooglœa mass was noticed composed of large cocci-like bodies, and, since these had not occurred during the bacteriological analyses of healthy cultures, it was decided to isolate them. Colonies on plates were accordingly prepared, and a pure culture (fig. 33) made on a nutrient agar slope. With this pure culture of the parasite we have been able to infect healthy pure mixed cultures of the amœba, and find the usual appearances of degeneration and death and comparative absence of encystment as in the original tubes. Steps are now being taken to try to infect with this parasite a culture of amœba from dysenteric stools kindly sent to us by Dr. J. W. Stephens, of Liverpool, and it is also proposed to find out if the parasite will destroy other protozoa, particularly the pathogenic varieties.<sup>1</sup>

<sup>1</sup> While this volume was in the press we have been able to infect, with the parasite, cultures of an amœba obtained from pond water and apparently also cultures of two flagellates, namely, *Polytoma granulosa* and *Bodo grandis*. *Bodo saltans* appears to be unaffected by it. We think the injurious effect of the parasite is due to some intracellular poisonous substances, since the parasite will only destroy those organisms which actually ingest it. We have so far been unable to kill the amœbæ with extracellular products.



FIG. 32.—Photomicrograph of amoebæ which are in a culture infected with the parasite.



FIG. 33.—Photomicrograph of a pure culture of the amoeba parasite.



Parasites have already been described by others in various protozoa, particularly in those which by degenerating have become susceptible to infection. The one we have isolated appears very similar to that described by Nägler as a facultative parasitic micrococcus of amoeba. Dr. E. H. Ross has examined the parasite by the jelly method of staining, and informs us that it is probably a large micrococcus, containing one or more large masses of chromatin surrounded by a layer of clear cytoplasm, in which a variable number of scarlet-staining granules can readily be distinguished. He was also able to make out details of structure closely resembling those described by Mencl in *Micrococcus ochraceus*. An analysis showing the cultural and other characters of the parasite is appended.

## E.—PARASITE OF AMŒBA

Description . . .	A large coccus about 1.5 to 2 $\mu$ in diameter arranged in tetrads and as diplococci
Motility . . .	Non motile
Thermal death-point	Near 60° C. (for 10 minutes)
Ærobie or anærobie .	Facultative anærobie
Staining reactions .	C.M.B. fairly well A.G.V. well C.F. well
Gram . . . .	Negative It is very easily decolourised when stained by any stain
Pleomorphism .	None
Agar stroke 37° C. .	Thick, moist, raised, yellowish-white growth, very vigorous; is inclined to become lemon-yellow in colour in old cultures
Gelatin stab 20° C. .	Good growth, rather nail-like in character, marked surface growth, heaped up. No liquefaction
Broth 37° C. . . .	Clear, no scum, deposit at bottom and on sides of tube
Colonies . . . .	Circular, very minute, hyaline Look like extremely small drops of dew
Remarks . . . .	Was originally isolated from a tube of amœbæ which were in a very abnormal state. No spores. No acid production on litmus glucose agar
Name . . . . .	Parasitic micrococcus of amœba Not identified



## BIBLIOGRAPHY

- ALEXEIEFF, A.: "Sur la division nucléaire et l'enkystement chez quelques Amibes du groupe *limax*," *C.R.S.B.*, LXX., 1911.
- AWERINZEW, S.: "Teilung von *Amœba proteus*," *Z.A.*, XXVII., 1904.
- CALKINS, GARY N.: "Evidences of a Sexual Cycle in *Amœba proteus*," *A.P.K.*, V., 1904.
- "Fertilization of *Amœba proteus*," *B.B.*, XIII., 1907.
- "Regeneration and Cell-division in *Uronychia*," *J.E.Z.*, X., 1911.
- "Effects of Mutilations by Cutting, on *Paramœcium*," *B.B.*, XXI., 1911.
- CALKINS, GARY N. AND CULL, SARA W.: "The Conjugation of *Paramœcium aurelia (caudatum)*," *A.P.K.*, X., 1907.
- CHATTON, E.: "La structure du Noyau et la Mitose chez les Amœbiens," *A.Z.E.*, V., 1910.
- CRAIG, C.F.: "The Amœbæ in the Intestine of Man," *Journ. Infect. Diseases*, V., 1908.
- DOBELL, C. C.: "Physiological Degeneration and Death in *Entamœba ranarum*," *Q.J.M.S.*, LIII., 1909.
- DOFLEIN, F.: "Amöbenstudien," *A.P.K.*, Suppl. i., 1907.
- DREW, A. H.: "Auxetic Action on the Spores of a New Species of *Polytoma*," *Knowledge*, March 1913.
- FANTHAM, H. B.: "The Amœbæ Parasitic in the Human Intestine," *A.T.M.P.*, V., 1911.
- GAUDUCHEAU, A.: "Formation de Corps spirillaire dans une Culture d'Amibe (*Entamœba phagocytoïdes*)," *C.R.S.B.*, LXIV., 1908.
- GLASER, H.: "Untersuchungen über die Teilung einiger Amöben, etc.," *A.P.K.*, XXV., 1912.

- GOODEY, T.: "The Excystation of *Colpoda cucullus* from its Resting Cysts, and the Nature and Properties of the Cyst Membranes," *Proc. Roy. Soc., B.*, LXXXVI., 1913.
- GROSSE-ALLERMANN, W.: "*Amæba terricola*," *A.P.K.*, XVII., 1909.
- GRÜBER, K.: "Eigenartige Körperformen von *Amæba proteus*," *A.P.K.*, XXIII., 1911.
- "Biologische und experimentelle Untersuchungen an *Amæba proteus*," *A.P.K.*, XXV., 1912.
- HARTMANN, M.: "Die Dysenterie-Amöben" in a "Handbuch der Pathogenen Protozoen," by Prowazek, S.V., and others, 1911.
- HERTWIG, R.: "Die Protozoen und die Zelltheorie," *A.P.K.*, I., 1902.
- JENNINGS, H. S.: "What Conditions induce Conjugation in *Paramœcium*?" *J.E.Z.*, IX., 1910.
- LÉGER, L., AND DUBOSQ, O.: "Deux grégarines des Crustacés," *A.Z.E.*, 1911.
- LIPSKA, L.: "L'influence de l'Inanition chez *Paramœcium caudatum*," *Rev. Suisse. Zool.*, XVIII., 1910.
- LISTON, W. GLEN, AND MARTIN, C. H.: "Contributions to the Study of Pathogenic *Amæbæ* from Bombay," *Q.J.M.S.*, LVII., 1911.
- MENCL, E.: "Über den Kern und seine Teilung bei *Sarcinen* und *Micrococcus ochraceus (butyricus)*," *A.P.K.*, XIX., 1910.
- MERCIER, L.: "L'amibe de la Blatte (*Entamæba blattæ*)," *J.E.Z.*, IX., 1910.
- METCALF, M. M.: "Studies upon *Amæba*," *J.E.Z.*, IX., 1910.
- MINCHIN, E. A.: "An Introduction to the Study of the Protozoa," London, Edward Arnold, 1912.
- MOUTON, H.: "Recherches sur la degestion chez les Amibes, et sur leur diastase intracellulaire," *Annales de L'Institut Pasteur*, t. XVI., 1902.
- MUSGRAVE, W. E., AND CLEGG, M. T.: "Amœbas, their Cultivation and Etiologic Significance." Manila, *Dept. of the Interior, Bureau of Govt. Laboratories Biol. Lab.*, XVIII., 1904.

- NÄGLER, K.: "Fakultativ parasitische Micrococcen in Amöben," *A.P.K.*, XIX., 1910.
- "Entwicklungs geschichtliche Studien über Amöben," *A.P.K.*, XV., 1909.
- NOWIKOFF, M.: "Die Wirkung des Schilddrüsenextrakts auf Ciliaten," *A.P.K.*, XI., 1908.
- PENARD, E.: "Observations sur les Amibes à pellicule," *A.P.K.*, VI., 1905.
- POPOFF, M.: "Über den Entwicklungscyclus von *Amœba minuta*," n. sp., etc., *A.P.K.*, XXII., 1911.
- PROWAZEK, S. VON: "Beitrag sur Entamœba-Frage," *A.P.K.*, XXII., 1911.
- RHUMBLER, L.: "Die Oberflächenkräfte der Amöben," *Z.W.Z.*, LXXXIII., 1905.
- ROSS, H. C.: "On the Determination of a Coefficient by which the Rate of Diffusion of Substances into Living Cells can be ascertained," *Proc. Roy. Soc.*, B., Vol. LXXXI., 1909.
- "On the Death of Leucocytes," *Journal of Physiology*, XXXVII., 1908.
- "On the Vacuolation of Leucocytes and the Liquefaction of their Cytoplasm," *Journal of Physiology*, XXXVII., 1908.
- ROSS, H. C., AND CROPPER, J. W.: "Induced Cell-reproduction and Cancer," London, John Murray, 1910. Also "Further Researches into Induced Cell-reproduction and Cancer," Vol. I., 1911; Vol. II., 1912; Vol. III., 1913. London, John Murray.
- SWELLENGREBEL, N. H.: "Notiz über eine neue freilebende Amöbe," *Amœba salteti*, n. sp., *A.P.K.*, XIX., 1910.
- THOMAS, —?: "The Action of Chemical Agents on *Amœba*," Manila, *Bureau of Govt. Labs.*, 1905.
- VAHLKAMPF, E.: "Biologie und Entwicklungs-geschichte von *Amœba limax*," *A.P.K.*, V., 1905.
- VERWORN, M.: "Biologische Protisten-Studien," *Z.W.Z.*, XLVI., 1888.
- WALKER, E. L.: "*Amœbæ* in the Manila Water Supply," etc., *Philippine Journ. Sci.*, VI. (B), 1911.

- WHERRY, W. B.: "Studies on the Biology of an Amœba of the Limax Group," *Vahlkampfia* sp. No. 1, *A.P.K.*, XXXI., 1913.
- WHITMORE, E.: "Kulturamöben aus Manila," *A.P.K.*, XXIII., 1911.
- WOODRUFF, L. L.: "Evidence on the Adaptation of *Paramœcia* to Different Environments," *B.B.*, XXII., 1911.
- "The Effect of Excretion Products of *Paramœcium* on its Rate of Reproduction," *J.E.Z.*, XI., 1911.
- WOODRUFF, L. L., AND BAITSELL, G. A.: "The Reproduction of *Paramœcium aurelia* in a 'Constant' Culture Medium of Beef Extract," *J.E.Z.*, XI., 1911.
- — "The Temperature-coefficient of the Rate of Reproduction of *Paramœcium aurelia*," *Amer. J. Physiol.*, XXIX., 1911.
- WÜLKER, G.: "Die Technik der Amöbenzucht," *Centralbl. Bakt. Jena*, Abt. I., 50; Ref. 1911.

## ABBREVIATIONS

- A.P.K.* Archiv für Protistenkunde (Jena).
- A.T.M.P.* Annals of Tropical Medicine and Parasitology (Liverpool).
- A.Z.E.* Archives de Zoologie expérimentale et générale (Paris).
- B.B.* Biological Bulletin (Woods Holl., Mass.).
- C.R.S.B.* Comptes-rendus hebdomadaires des Séances et Mémoires de la Société de Biologie (Paris).
- J.E.Z.* Journal of Experimental Zoology (Philadelphia).
- Q.J.M.S.* Quarterly Journal of Microscopical Science (London).
- Z.A.* Zoologischer Anzeiger (Leipzig).
- Z.W.Z.* Zeitschrift für wissenschaftliche Zoologie (Leipzig).

The Bibliography has been written with the aid of the Records of Works on Protozoa compiled by Dr. H. M. Woodcock.



## INDEX

- Acids, action of, 37  
 Alkalies, action of, 36  
 — effect of, on excystation, 60 *et seq.*  
 Amœba, general description of, 15  
 — life-history of, 32  
 — relation of bacteria to, 16  
 — type of, employed, 17  
 — variation in size of, 29  
*Amœba ostrea*, 18  
 — — a parasite of, 102 *et seq.*  
 — — characters of, 27, 28  
 — — cultivation of, 18 *et seq.*  
 — — ingestion of food by, 30  
 — — life-history of, 33 *et seq.*  
 — — long, slender form of, 38, 39  
 — — movements of, 29  
 — — pure cultures of, 71 *et seq.*  
 — — mixed cultures of, 77 *et seq.*  
 — — quiescent type of, 51  
 — — *radiosa*, types of, 42  
 Amœbulæ, 35, 37, 39  
 Asparagin (auxetic), 37  
 Auxetics, 7, 8, 34, 37 *et seq.*, 55, 74, 76  
 Bacterial products, effect of, on amœbæ, 47, 52, 54, 57, 59, 62, 66 *et seq.*, 71 etc.  
*B. brunneum*, 83, 91  
*B. flavo coriaceus*, 83  
*B. fluorescens liquefaciens*, 67, 69, 72, etc.  
 — — *non-liquefaciens*, 84  
*B. proteus vulgaris*, 86  
*B. subtilis*, 91  
 Bacteriological analysis, 95 *seq.*  
 Binary fission, 33, 34  
*Bodo*, 81, 104  
 Brownian movement, 31  
 Budding, 34  
 Cadaverine (kinetic and augmentor), 53, 54  
 Cancerous tumours, 55  
 Centriole (nucleolus or centrosome), 27  
 “Chloroformed solution” of bacterial products, 67, 75, etc.  
 Choline hydrochloride (kinetic and augmentor), effect of, on excystation, 63  
 — — effect of, on reproduction, 41, 69, 72, 73  
 Chronic irritation, 54, 55  
 Coefficient of diffusion, 25  
 Conjugation of amœbæ, 35  
 Contractile vacuole, 28, 31  
*Corpuscles chromatoides*, 26, 31  
 Creatine (auxetic), 40, 69  
 Cysts, 17, etc.  
 — action of drying on, 60, 84, 91  
 — age of, 59  
 — conjugation, 35, 49  
 — *dauer*, 47 *et seq.*  
 — isolation of a single, 78, 79, 87, 88, 89  
 — new method of staining, 26



- Cysts, resistance of, 59  
 Cytoplasmic granules, 28
- Depression periods, 51  
 Drought, influence of, 49 *et seq.*
- Encystment, 17, 47 *et seq.*  
 Environment, effect of, 17, 29, 56, etc.  
 — adverse conditions of, 28, 46  
 — suitable conditions of, 56, 57  
 Excystation, 17, 49, 56 *et seq.*, 76  
 — action of choline on, 63  
 — effect of alkalinity on, 60  
 — ferments, the cause of, 58, 68, 71, 76  
 — food, the stimulus to, 57  
 — influence of bacterial products on, 64  
 — rate of, 58
- Ferments, the cause of excystation, 58, 68, 71, 76  
 — possible action of, in reproduction, 71, 72, 74, 75, 76  
 Fixation, new method of, 26  
 Food, 38 *et seq.*, 68, 69, 73  
 Formalin, 91
- Gases, apparatus for testing effect of, 23  
 Gelatin-liquefying bacteria, 65  
 Germicides, 91 *et seq.*
- Heat, action of, on cysts, 84, 90  
 Hydrochloric acid, 66, 84, 85, 93
- Jelly method, advantages of, 23  
 — — staining by the, 24
- Karyosome, 27, 68
- Kinetics, 37 *et seq.*, 55, 74, 76, 78, etc.
- Live slide, 20
- Media for cultures, 24  
 Mercuric chloride, action of, on cysts, 83, 92  
 Methods of examination, 18 *et seq.*  
 Migration of amœbæ, 89  
 “Moist-air-chamber” method, 21  
 Multiple fission, 34
- Neurine, 70  
 Nucleus, 24, 25, 28
- Osmosis, 48, 51, 58
- Paraffin wax cell, 22  
 Parasite of amœba, 102 *et seq.*  
 Pepsin, 68  
 Petri dish, brass, for special observations of amœbæ, 23  
*Polytoma granulosa*, 8, 47  
 “Pure cultures” of amœba, 71, 77  
 “Pure mixed cultures” of amœbæ, 77 *et seq.*
- Radiosa types, 42
- Salts, action of, 29, 58  
 Serum, normal horse, 72, 74  
 Sex, possible differentiation of, 39  
 Sporing bacteria, removal of, 81  
 Staining, jelly method of, 24  
 Starvation, 51
- Tyrosin (auxetic), 39, 40, 72, 73, etc.
- Volutin granules, 28







