

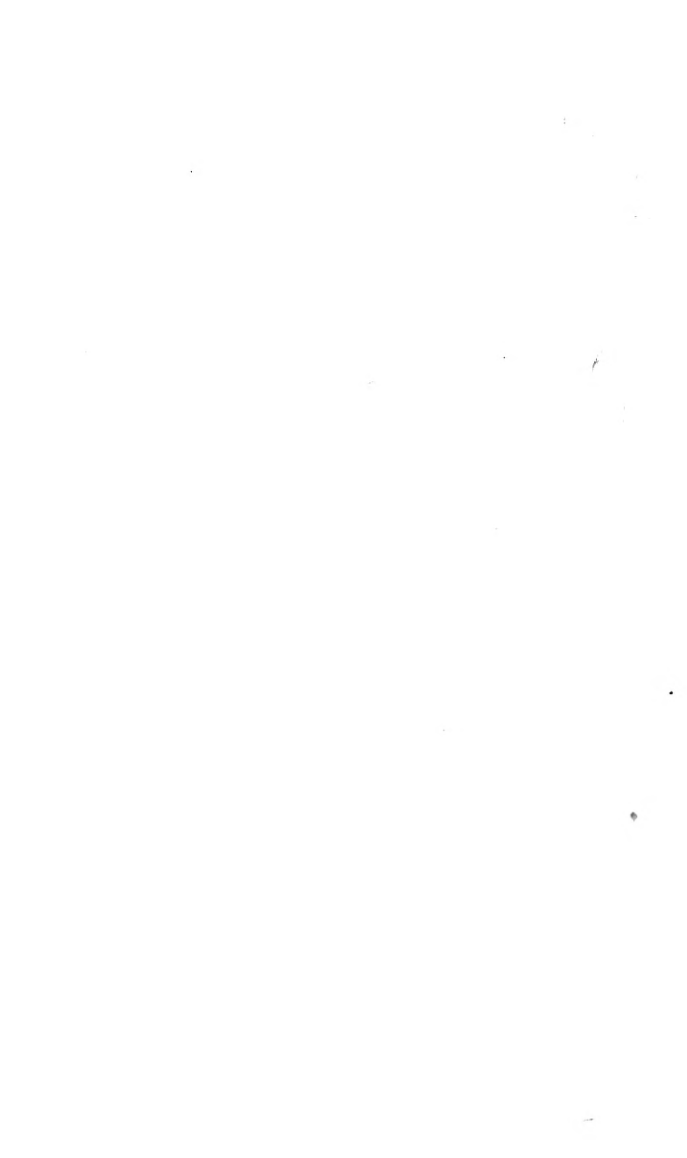

UNIVERSITY of CALIFORNIA  
AT  
LOS ANGELES  
LIBRARY









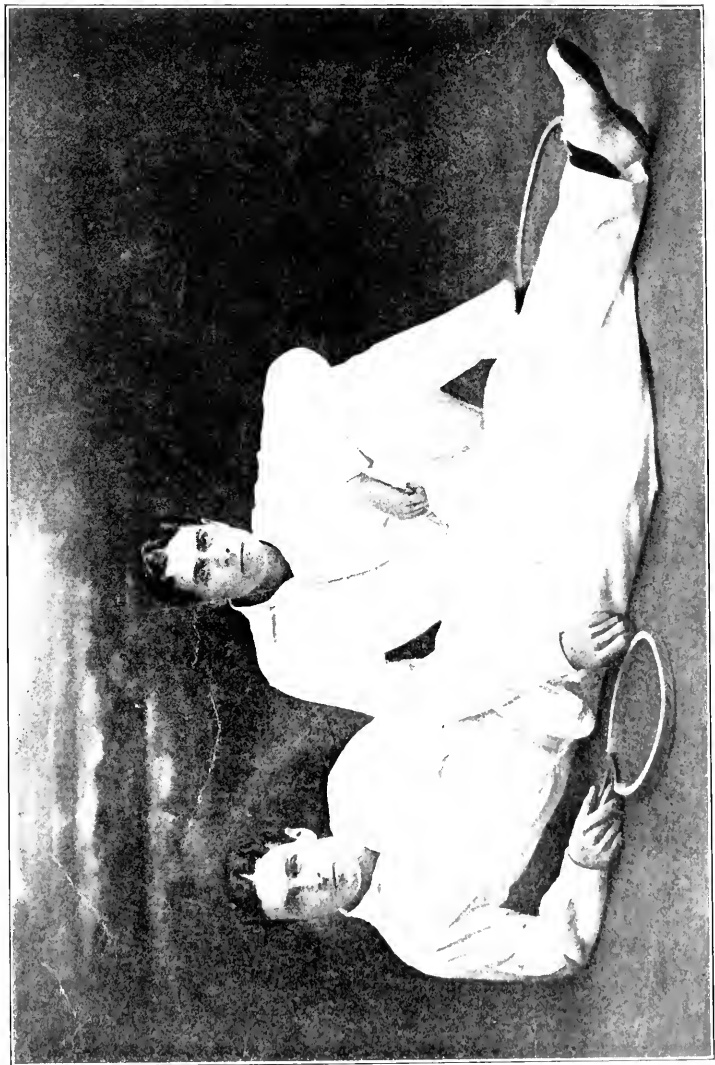

MR. R. F. AND H. L. DOHERTY.



R. F. & H. L. DOHERTY

ON

L A W N T E N N I S

---

NEW YORK: THE BAKER & TAYLOR COMPANY  
33-37 EAST SEVENTEENTH STREET, UNION SQUARE, NORTH

40908

Copyright, 1903,

BY

THE BAKER & TAYLOR COMPANY.

Entered at Stationers' Hall, London.

---

*Published August, 1903.*

AMERICAN PRINTING HOUSE,  
318-320 E. 23d STREET.

THIS BOOK IS DEDICATED TO



HER IMPERIAL HIGHNESS

THE GRAND DUCHESS ANASTASIE

OF MECKLENBURG-SCHWERIN,

WHO HAS DONE SO MUCH TO PROMOTE  
THE GAME ABROAD



## PREFACE.

OUR object in writing this book has been to give beginners a brief and simple and pictorial guide to improvement at our favourite game, so that they may enjoy it far more than they do now. For we believe the commonest mistakes of the average player to be so large and yet so few that when once he is told what they are he will be able to correct them quite easily and add wonderfully to his success. At present he is not giving himself a fair chance if he is holding his racket wrongly, stopping his stroke sharply instead of following it through, and so on.

The illustrations (take, for instance, those which illustrate the racket being held and the stroke being followed through) are meant to show beginners what we do, not because it is quite certainly best for all,

Dem. 1021

but because it may very probably be good for many. That is the spirit in which we offer these pages trying to give hints, as full and clear as we can make them, as hints and suggestions, not as rules and laws. In fact, we have included a number of different features from the play of many experts in America as well as in England, after our delightful visit to the States.

But, though English and American players vary in style from one another and among themselves, yet constant play against all sorts of opponents in all sorts of places under all conditions—on courts of grass, wood, gravel, sand, asphalt, concrete; in weather dull, rainy, bright, burning—has made us sure that there are some instructions which can have very few exceptions. On these general principles we have laid great stress, and in order to impress them upon the reader we have purposely left out a great deal about the history of the game, &c.

Among the instructions for all ordinary play are the following. Concentrate your whole mind on the game and never slack off; get ready and

in position in good time before you have to make your stroke; when once your opponent has made his stroke, keep your eye on the ball up to the last possible fraction of a second (this is especially hard if he has run up to the net, in which case you must simply forget that he is there); put weight into the stroke (this means partly the turn of the body on the hips, and partly the shoulder-movement, as well as the wrist overturn); follow through; after the stroke, recover the balance of the body and the place in the court as quickly as you can. In service, begin with the right shoulder back and down, and the head back, and throw the ball high. In Singles, play against many different opponents, and practise your weak points except during matches. In Doubles, remember which balls you should be responsible for; keep or get parallel with your partner, as a rule; and keep or get your regular distance from him. These are the points on which we have ventured to insist with some conviction.

We do not believe that the Lawn Tennis public is inclined to enter deeply into elaborate theories as to the strokes and tactics; we have described

all that the Lawn Tennis public is likely to require and to use for ordinary purposes. If we have omitted anything, this is not because we want to keep it back: we have told all our "secrets," and some of them seem to us almost too obvious to need mention; but we have been often assured that players do really want to know just these very things. If there are other things on which information is needed, we shall be grateful to hear of them, so that we may explain them to the best of our ability in case a second edition of the book is called for. For fresh information up to date we may safely refer readers to the paper "Lawn Tennis," the official organ of the Lawn Tennis Association.

We take the opportunity of thanking those who have helped us in the preparation of the work.

R. F. & H. L. DOHERTY.

4 ALBERT HALL MANSIONS, LONDON, S. W.



# CONTENTS.

CHAPTER	PAGE
I. THE STROKES . . . . .	17
II. SINGLES . . . . .	70
III. DOUBLES AND MIXED DOUBLES:	
I. DOUBLES . . . . .	82
II. MIXED DOUBLES . . . . .	94
IV. HINTS ON PRACTICE, TRAINING, AND MATCH PLAY:	
I. PRACTICE AND TRAINING . . . . .	102
II. MATCH PLAY . . . . .	105
V. BRIEF NOTES FOR BEGINNERS, WITH A LIST OF COMMON FAULTS . . . . .	108
VI. OUR IMPRESSIONS OF PLAY AND PLAYERS IN AMERICA . . . . .	116
VII. LADIES' PLAY (BY MISS TOUPIE LOW- THER) . . . . .	132
VIII. SOME HINTS ON THE CONSTRUCTION AND CARE OF GRASS COURTS (BY MR. GEO. W. HILLYARD) . . . . .	141
IX. HOW LAWN TENNIS COMPARES WITH SOME OTHER GAMES (BY EUSTACE MILES. . . . .	151

CHAPTER	PAGE
X. LISTS OF CHAMPIONS, RULES AND REGULATIONS, ETC.:	
I. COVERED COURT CHAMPIONSHIPS . . . . .	157
OXFORD <i>v.</i> CAMBRIDGE . . . . .	161
II. LIST OF CHAMPIONS . . . . .	164
HOW TO MARK OUT A COURT (WITH DIAGRAM) . . . . .	184
REGULATIONS FOR THE INTERNATIONAL LAWN TENNIS CHAMPIONSHIP . . . . .	187
REGULATIONS FOR THE MANAGEMENT OF LAWN TENNIS PRIZE-MEETINGS . . . . .	194
RECOMMENDATIONS . . . . .	215
LAWS OF THE GAME (WITH PLANS OF COURTS) . . . . .	217
KNOTTY POINTS . . . . .	232

# ILLUSTRATIONS.

NO.	R. F. & H. L. DOHERTY . . . . .	<i>Frontispiece</i>
	HER IMPERIAL HIGHNESS THE GRAND DUCHESS ANASTASIE OF MECKLENBURG- SCHWERIN . . . . .	PAGE vii
1.	GRIP FOR FOREHAND . . . . .	19
2.	GRIP FOR BACKHAND . . . . .	23
3.	SERVING: THE BALL HAS JUST BEEN THROWN UP . . . . .	27
4.	FINISH OF SERVICE . . . . .	31
5.	THE START OF AN AMERICAN SERVICE, AS WARD DOES IT . . . . .	35
6.	HALF-WAY THROUGH THE AMERICAN SERV- ICE . . . . .	39
7.	WHERE THE RACKET COMES AT THE FINISH OF THE AMERICAN SERVICE . . . . .	43
8.	THE BEGINNING OF THE AMERICAN "RE- VERSE" SERVICE . . . . .	47
9.	HALF-WAY THROUGH THE AMERICAN "RE- VERSE" SERVICE . . . . .	51
10.	THE RACKET AT THE BEGINNING OF THE SWING, AS ONE WAITS FOR A SMASH . . . . .	55
11.	BEFORE SMASHING A BALL . . . . .	59
12.	POSITION OF THE FEET FOR A FOREHAND DRIVE . . . . .	63
13.	THE SWING BACK FOR A FOREHAND DRIVE	67

NO.	PAGE
14. STEPPING INTO THE BACKHAND POSITION . . . . .	71
15. POSITION OF THE FEET FOR A BACKHAND DRIVE . . . . .	75
16. BACKHAND DRIVE, TOP HAVING BEEN PUT ON THE BALL . . . . .	79
17. FINISH OF BACKHAND DRIVE . . . . .	85
18. THE FINISH OF A BACKHAND DRIVE ACROSS THE COURT . . . . .	91
19. POSITION AS ONE WAITS FOR A VOLLEY AT THE NET . . . . .	97
20. LOW FOREHAND VOLLEY . . . . .	103
21. LOW BACKHAND VOLLEY . . . . .	109
22. W. A. LARNED, CHAMPION OF THE UNITED STATES 1901, 1902 . . . . .	117
23. M. D. WHITMAN, CHAMPION OF THE UNITED STATES 1898, 1899, 1900 . . . . .	121
24. D. F. DAVIS AND H. WARD, THE AMERICAN TEAM THAT PLAYED AGAINST ENGLAND IN DOUBLES, 1900 . . . . .	127
25. ROBERT D. WRENN . . . . .	129
26. CENTRE COURT AT WIMBLEDON WHERE THE ALL-ENGLAND MATCHES ARE PLAYED . . . . .	143
27. THE CHAMPIONSHIP COURT AT NEWPORT, WHERE THE UNITED STATES MATCHES ARE PLAYED . . . . .	149

## DIAGRAMS IN THE TEXT

HOW TO MARK OUT A COURT . . . . .	184
PLAN OF COURTS . . . . .	231

R. F. & H. L. DOHERTY  
ON  
LAWN TENNIS



R. F. & H. L. DOHERTY  
ON  
LAWN TENNIS.

CHAPTER I.

THE STROKES.

IN this chapter and all through the book we wish to describe what we find it best to do (or attempt to do) in Lawn Tennis rather than what everyone should do. Each player should find out for himself his best positions and strokes; they may be like ours, or they may not. When he has found them, he should practise them and try to come as near to them as he can in actual play. He will not always have time to get the very best during a quick game; in that case he must be content with something as like it as possible. Even the most successful players are taken unawares now and then, and must just use whatever device is ready to hand.

## THE GRIP AND POSITION OF THE RACKET.

The grip of the racket is a most important matter. It need not necessarily be the same as ours, but we offer ours for what they are worth. Very nearly every first-class player has almost the same grip as ours. Little description is needed if the reader studies the illustrations carefully.

Should one change one's grip for the fore-hand and backhand strokes? Many players do so, even if they are not aware of it; probably all American players do. Of ourselves R. F. changes his grip less than H. L., because he grips slightly differently. There is no doubt that it is better to change the grip a little at Lawn Tennis. Both Renshaws did; so do Pim, Chayton, Mahony, Meers, Hillyard, Riseley, &c. We might, however, say that at the beginning the less change the better, so that the learner may not have too many things to attend to. The Baddeleys never changed their grip at all, and it seems to have been partly owing to this that their backhand



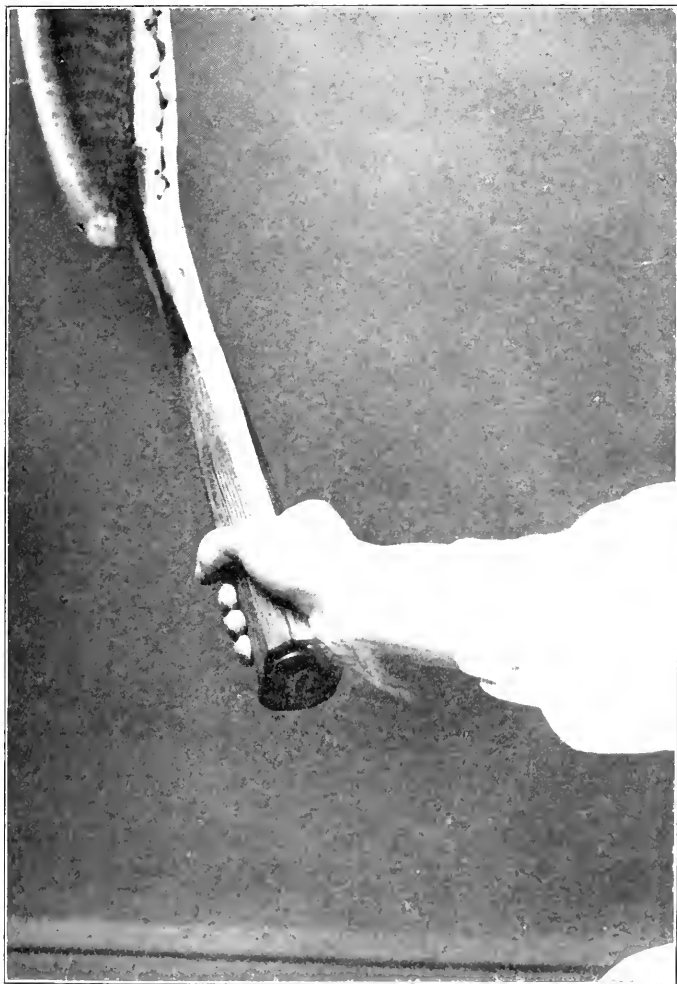

No. 1—GRIP FOR FOREHAND.



strokes were their weakest. The best grip for a forehand stroke cannot well be exactly the best grip for a backhand stroke also.

Anyhow, the handle should be held firmly. Most people find a big handle easier to grip than a small one. The fingers should be spread out, though for a backhand grip they may be somewhat closer. Ought the thumb to be used to support the racket during a backhand stroke? Burke, Pim, Eaves, and nearly all the good players use the thumb in this way, keeping it not straight up the handle but rather across the handle. For a backhand smash, however, the thumb should always be up the handle.

We keep the head of the racket above the wrist whenever we can, and always on the volley; and we also keep the hand back—that is to say, bent back (toward the shoulder) at the wrist—so that the ball may not go outside the side-lines.

Between the strokes we think it best to support the racket by resting the splice upon the left hand. This is the common habit of Americans and nearly all good players, and helps consider-

ably, especially when there is to be a quick volley at the net.

#### WHILE WAITING.

The grip of the racket should be firm but not tight. Of the position of the racket (which nearly every player supports with his left hand) we have just spoken. The right waiting-position here, as at Cricket, is the position from which one can most easily and quickly pass into the right position for one or another stroke. But there is this difference between Lawn Tennis and Cricket or Racquets or Tennis. In these games one runs forward or backward in the sideways position—that is, in the position in which one will make the strokes. In Lawn Tennis one seldom has time to do this: the distance to be covered is too great. One must be content to run backwards and forwards in the ordinary way, and then to form the position. It is important to be able to run back well, especially for lobs; and to recover quickly so as to have one's balance, and to be able to use one's body-weight and power. Many players

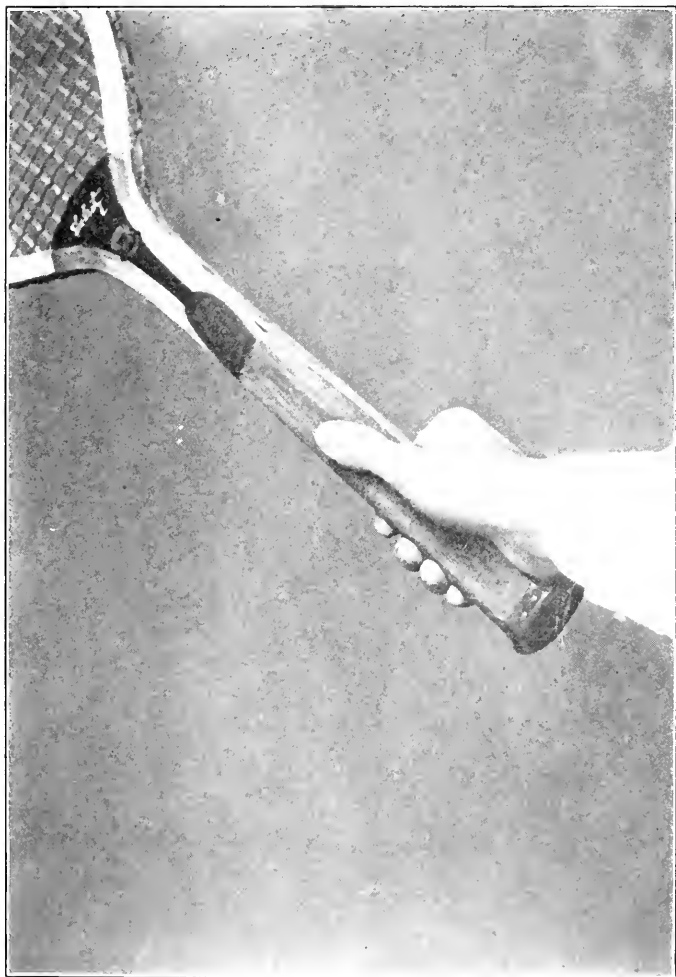

No. 2,—GRIP FOR BACKHAND.



after they have made their stroke stand still until the ball is already returned, and then they rush at it. It is far better not to wait but to anticipate, and to be already in the right place in good time; then one can wait quietly.

#### THE ORDINARY STROKE.

What should be the right distance of the ball from the ground and from one's bat when one takes it? As to the height at which one can drive a ball well from the back of the court, it should certainly be above the knee, and H. L. prefers it to be above the waist. We both think it best to drive the ball at the top of the bound or a little later. R. F. thinks that one should take the ball as high as one can, yet not so high that one cannot get well over it, in order to put top on the ball. To get over the ball enables one to hit it harder and to keep it in. Lewis's backhand stroke, which was one of the best and most severe ever seen, got well over the ball; although a considerable pace can be put on when it is allowed nearly to fall, as at Racquets. Hobart makes his

strokes in this way. Few players can rely upon hitting a rising ball accurately; W. Renshaw could, and so can Caridia, but the ground must be especially good.

As to the distance of the ball from the player, it is a good general rule to keep away from the ball.

Another good piece of advice is to meet the ball squarely, to meet it and not to let it meet you—that is to say, to attack and not merely to stop.

Then there is the rule to follow through with the racket towards the spot to which one wants to hit the ball.

But most important of all is the rule to keep one's eye on the ball altogether if one can. The hardest occasion is when one's opponent is running up to the net. One must simply forget him altogether, as Smith does. In returning the service this rule is of the greatest importance, and especially in returning the American service. One may have a dim idea where one's opponent is, but the eye must be glued upon the ball.

The next question is how to add pace. Some players take a step forward in some of their



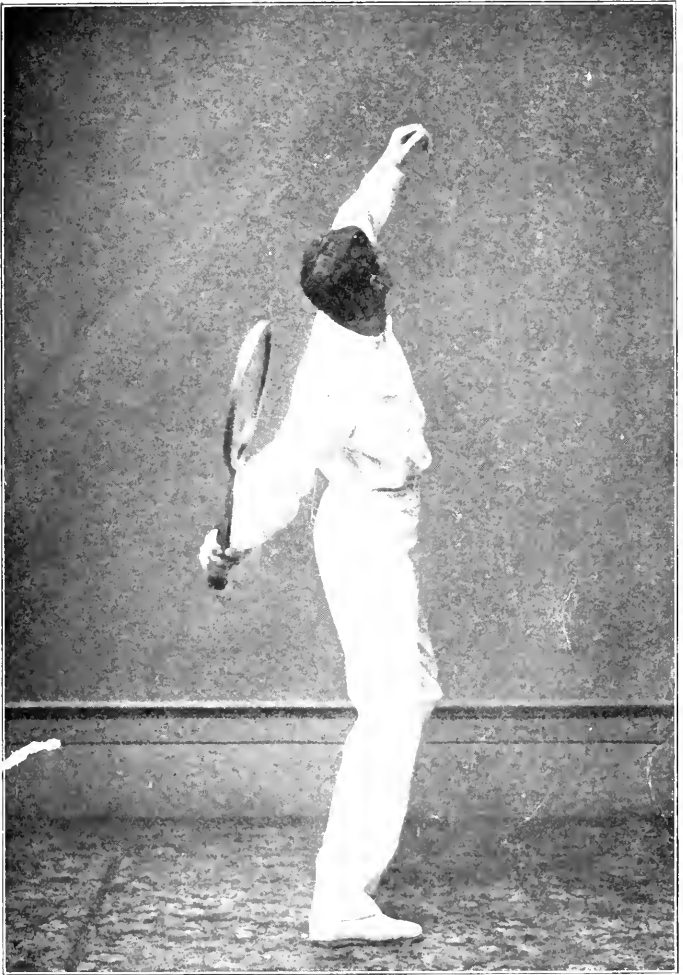

No. 3.—SERVING: THE BALL HAS JUST BEEN THROWN UP.



strokes. The best means, however, of adding pace is to use the body-swing, and follow through with the racket. People often imagine that pace is given by the wrist; but Smith's forehand drive, which is one of the fastest strokes we know, is given when the wrist is firm as a vise. Yet the wrist and the forearm can play a part in adding pace; they can and should help to give that top at the last moment, bringing the racket above the ball, and lending the ball a spin, the reverse of the cut at real Tennis. Besides this, there is some movement of the shoulder.

Pace, however, depends largely, as in Cricket, upon the correct timing of the ball.

#### SERVICE.

You should serve the ball, as a rule, not into the middle of the opponent's court, but to either side; generally it is better to serve to his backhand, for place is important as well as pace.

The hardest hit service is not always the best. Too great pace and severity in the first service is a common fault of beginners. Besides the fact

that it involves very much risk, there is this, that a slowly hit service gives the server time to get up to the net. This is of the greatest importance in a Double. In a Single, also, to-day it is usual to run in on a service, especially in America, partly owing to the fact that umpires do not call the foot-faults. The pace of your service should depend largely on whether you mean to run in on it or not. The general rule is to use the greatest pace which you can combine with the smallest number of faults. But too great a pace will take it out of you for the rally and the whole game. Besides this, you should vary your pace as a cricketer varies the pace of his bowling. After a number of hard services a slower one will be effective. The unexpected is valuable. Another variety, an unexpected variety, is to send the second service as hard as the first service. Your opponent generally advances a yard or so nearer to the net if your first is a fault, anticipating a slow second serve. It should be easy to send the second serve fast, because you ought to remember the mistake which you made in the first and correct it.

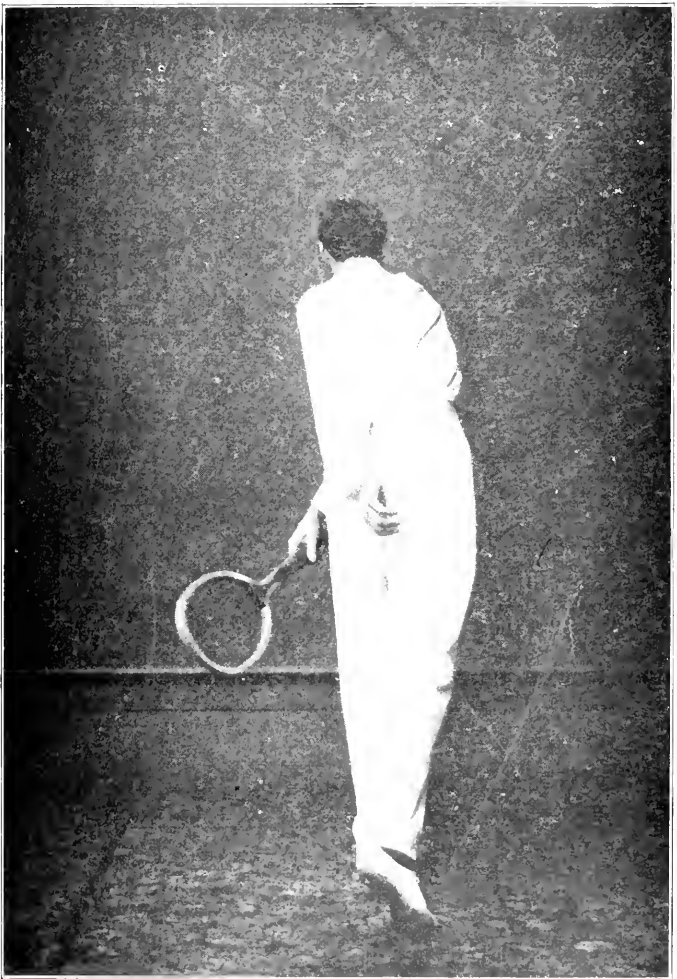

No. 4.—FINISH OF SERVICE.



Occasionally it may pay to send an underhand service. E. Renshaw once beat Lawford entirely through changing his overhead service to an underhand twist, and in a recent match on an American covered court Paret found a hard overhead service quite ineffective against Grant. By adopting a soft underhand service, however, he won the match.

Besides varying the pace one should also vary the place to which one serves. You must decide where to send the service, and perhaps keep that spot in your mind's eye. But then, when you have once thrown the ball up, you must not take the eye off it. In this, Lawn Tennis resembles Golf, only that in Lawn Tennis the player does not have the ball lying ready for him; he has to throw it up correctly with his left hand. One main reason why players serve so badly is that they take their eye off the ball.

Another reason is that they throw the ball up too much in front of them. The effect of this is that they hit it when it is too low, or else perhaps their body is wrongly posed, or wrongly used, or not used enough.

The body should not face the net, but should rather be at right angles to the net, so that it may get more power. For additional power the trunk should be bent far back, and the right shoulder should be well down. The whole art is to make the body work with the arms, and to direct the swing properly so as to get the full pace at the right moment.

When you are in the right position—that is to say, with the body at right angles to the net—bend well back from the hips, and, with the right shoulder well down, throw the ball straight up above the head and slightly above the right shoulder rather than the left, and somewhat behind rather than in front, so that you do not lose power. The eye must be kept steadily on the ball, and the ball must be hit directly it comes within reach. The higher you hit the ball the easier it is to keep it within the court. The racket should follow through and just miss the left knee. Some players occasionally hit their left knee with their racket, which is a good sign, but unpleasant. The position after the service is seen in illustration No. 4.



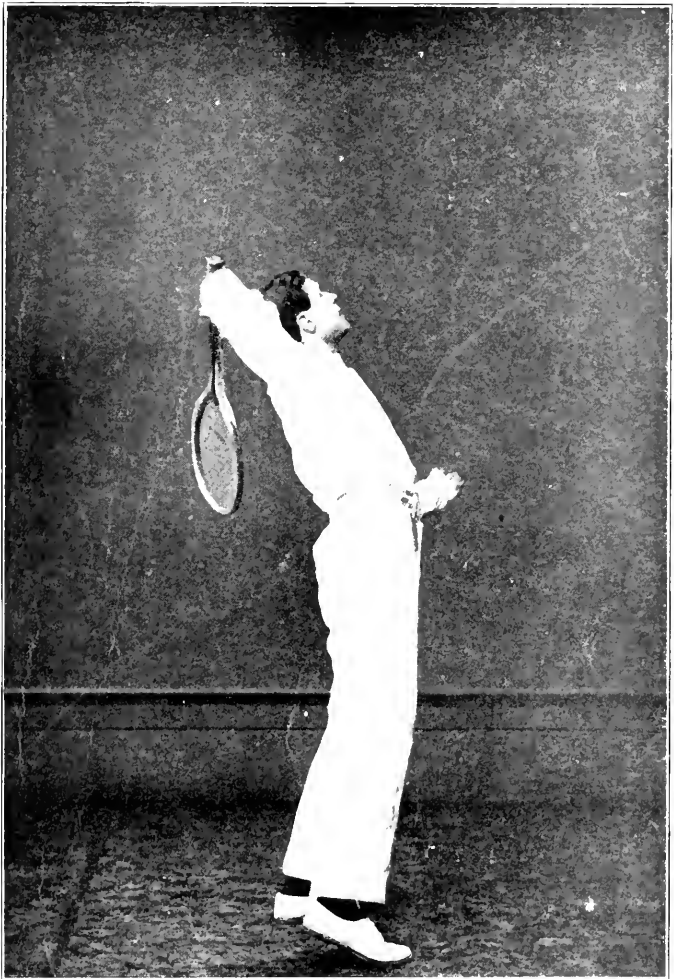

No. 5.—THE START OF AN AMERICAN SERVICE, AS WARD DOES IT



Of course this position should not be kept. The balance should be recovered, especially if one is going to run in on the service. When you run in, you must not sprint too hard, because thus you may be taken off your balance, or else surprised by a lob. Yet, on the other hand, it does not do to run in and get no further than the service-line. The service-line, or rather just behind it, is one of the worst places at which to take a return. If the return is a very good lob that you can only just reach, then do not try to kill it at once, but send it back with a good-length stroke at a fair pace. A lob or an easy ball will come back: then you can smash to the one side or the other, or now and then down the middle.

#### NOTES ON THE AMERICAN SERVICE.

The great number of players have not understood the chief advantage of the American service. For them it consists in the spin and the curious way in which the ball comes off the ground. This, of course, is puzzling at first, but one soon gets used to it. The chief advantage of the service is that it enables the server to get in

close to the net. The service of Whitman and Clothier drags considerably in the air and off the ground. The server gets up to the net sooner. Besides this, one has to return the service later—that is to say, when it is nearer the end of its flight—because of the spin on the ball. This same spin makes the placing of the ball less safe.

It is a question, however, to what extent this service spoils not only the game in general, but also the ordinary stroke of the man who has served it. The effects of the similar service in real Tennis have been to spoil the stroke not only of the opponent, but also of the server himself. After serving in this way it is almost impossible to recover the correct cut-stroke immediately.

The illustrations Nos. 5, 6, and 7 will best show the method of serving. One of them (No. 5) gives us the racket starting from behind the left shoulder and ending up beyond the right shoulder; going, in fact, right across. The ball travels on the racket itself from the wood at one side right to the wood at the other side. There is no service or stroke in which the ball touches so much of the gut of the racket.

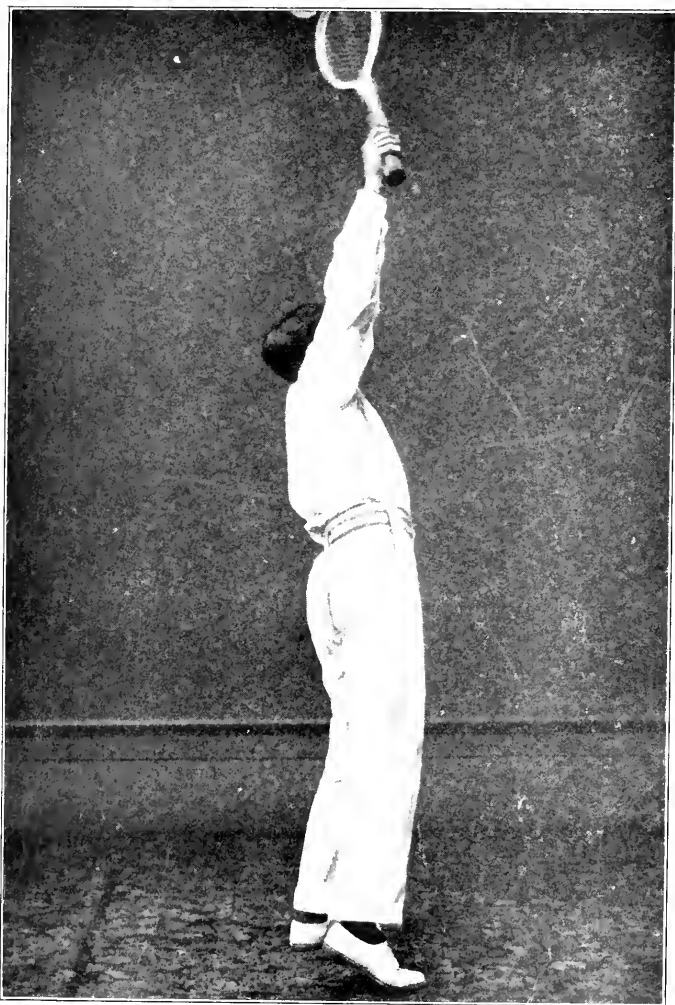

No. 6.—HALF-WAY THROUGH THE AMERICAN SERVICE.



## THE SMASH.

To smash well from any part of the court (and there is no reason why anyone who can hit the ball overhead at all should not be able to do this), one must know in what part of the court one is while taking the ball, and especially how far from the net. This is most important, as, the further one is away from the net, the higher one must hit the ball; one cannot hit the ball down so much, or it will go into the net. One must know how far one is to the right or left of the court, in order to be able to tell how much room one has to the left or right in which to place the ball. Good length is important when one is smashing, except when one gets a very short weak lob to kill; this one can hit very hard on to the ground, so that it bounds over the opponent's head.

The smash is very like the service, except that it is not from a defined position deliberately chosen. The player must be good on his feet, and especially good at running back. Instead of tak-

ing up his position carefully and throwing the ball precisely where he wants it to be, he has to take up his position quickly and be content with the ball which is hit to him.

He should not run back with his racket up in the air, though a few players, like Mahony, can do this and yet keep their poise. It is better (as in illustration No. 10) to keep the head of the racket down when he is running and moving, and not to start to swing till he is in position. Certainly he should never take his eye off the ball when he is smashing; that is the reason why so many smashes are missed.

The body should be not facing the net, but nearly sideways, and its weight and force should be used. At the beginning of the stroke, as in the service, the right shoulder should be down and the body and shoulder bent back. The head also should be thrown back. The racket must be swung well round behind the back. The weight of the body when one is taking the ball is first on the right foot and then is changed to the left, but sometimes the feet are in the air at the moment of striking. The stroke itself is rather like the



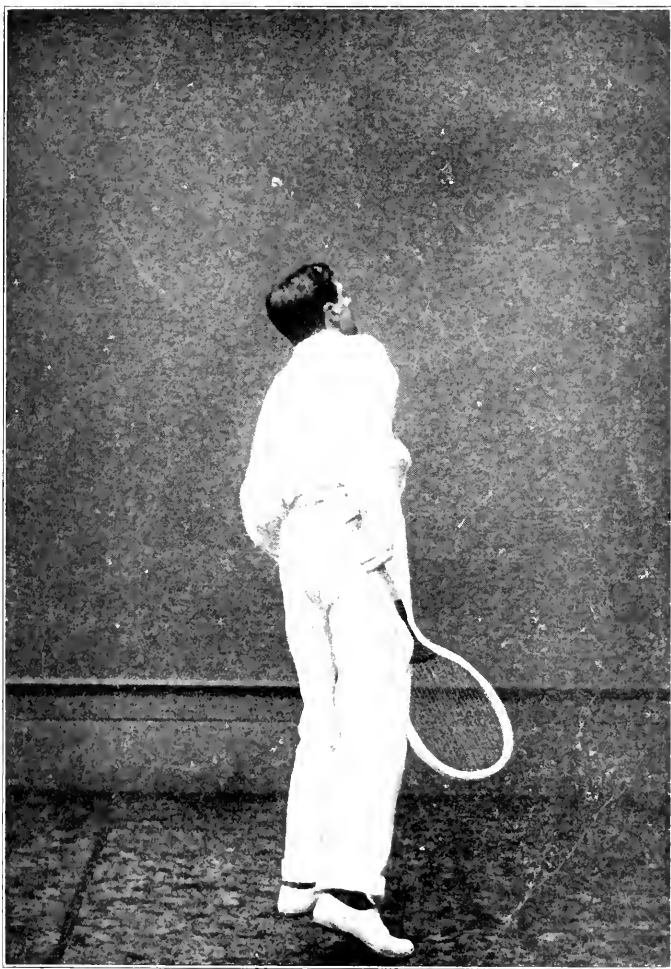

No. 7.—WHERE THE RACKET COMES AT THE FINISH OF THE AMERICAN SERVICE.



action of throwing, except that the arm must not be allowed to go far from the ear, and the racket follows through and down very much as in the service.

To be good overhead is the sign of a first-class player, even if a few have managed to get on without it. Gore rarely comes to the net, so rarely takes overhead balls. The aim should be certainty rather than severity, though the American aim is severity rather than certainty. We should advise most players not always to try to kill very good lobs, but to secure a good length and fair pace, and wait till the ball can be killed finally down one side or the other, or across, or now and then down the middle. Good length is a great requisite in killing. It does not pay always to smash to the same side. But in placing the ball, let us repeat, the eye must not be taken off even for the hundredth part of a second; it is by taking the eye off the ball to look at the place at which they are aiming, or to look where their opponents are, that nine out of ten players fail to smash well.

## THE BACKHAND SMASH.

In this stroke the thumb is made to go up along the handle in order to give power behind the stroke; but even with this support the backhand smash should only be played when the forehand smash is impossible, since it is one of the hardest strokes to do really well. Mahony does it to perfection. It is, of course, easiest to make across the court to one's opponent's backhand; sometimes, however, it should be made down the line.

The body faces sideways, as for the backhand stroke, and the weight of the body at the beginning of the stroke is on the left leg, whence it passes on to the right leg. The racket follows through as in the ordinary stroke.

## THE FOREHAND STROKE.

Although there will be times when one has come out of position, yet one should try to get as near to one's best stroke as possible; and one of the chief things to aim at is not to come too near

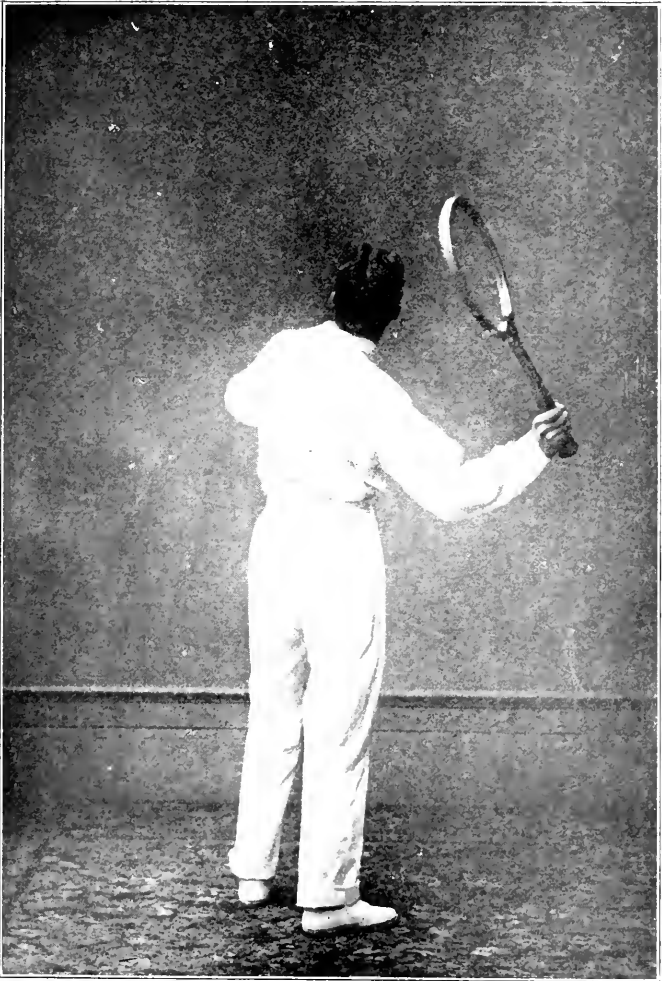

No. 8.—THE BEGINNING OF THE AMERICAN "REVERSE" SERVICE.



to the ball. First of all, one must not get too directly in its line, but should be rather to the left side of the line. Then, unless one is going to volley, one should be well behind the ball. It is better to have to run forwards (for this will add pace to the stroke) than either to run back, which will lose pace, or else to hit a rising ball, which will be risky.

There are two kinds of drives. The first is the drive when the ball is at the top of its bound, or just a little later. For this the head of the racket is up higher than the wrist. Then there is the drive off the lower ball, which certainly gives one more time to see what the ball is going to do. The advantage of the first kind is that one need not stand so far out of the court, nor give one's opponent so much time to get into position, nor put on so much pace for oneself, nor lift the ball so much. It is certainly far harder to volley a falling ball than a rising ball. The following remarks will apply to both these kinds of drives.

Get round—that is to say, face sideways—as much as you can. The feet should be in the position shown in diagram No. 12, though this will

differ according to the line in which the ball is approaching. The body should be facing the direction in which the ball will come; the knees should be slightly bent. The left leg will serve as the pivot. The weight of the body at the beginning of the stroke should be on the right leg, and should be transferred thence so that at the end of the stroke it is on the left leg. The left arm should hang loosely, and should come round with the body. The wrist of the right hand should be firm, but not stiff; the elbow should be a little bent. Before the stroke the racket should be swung well back with the right shoulder, which during the stroke comes round with the arm and then follows the ball through, the head of the racket moving right away in the direction intended, as if it were pointing and saying, "That's the spot where I was aiming."

We cannot repeat too often that you must not take your eye off the ball to see the spot to which you mean to hit the ball, or to see where your opponent is. First get in your mind's eye where he is or where you think he is; then get in your mind's eye where you mean to hit the ball, where



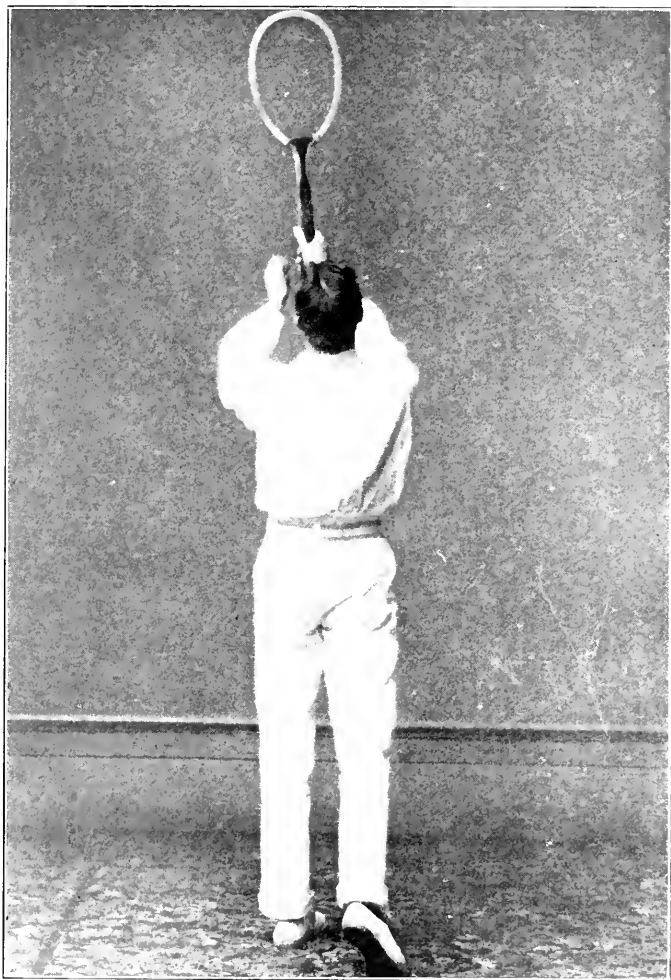

No. 9.—HALF-WAY THROUGH THE AMERICAN "REVERSE" SERVICE.



the net is, where the lines are, allowing a slight margin on the safety side for the height of the net and for the side and back lines; then keep your eye on the ball, as if you were a golfer.

### THE BACKHAND STROKE.

Here, again, practise and acquire the best stroke you can, and in play come as near to it as you can, though sometimes you will be caught out of position and unready.

The remarks already made as to the grip and as to the eye on the ball will apply here, and here also one must try to get above the ball, as in a forehand stroke, so that one may hit it harder; but this is far more difficult than in the forehand stroke, since if the ball rises above a certain height it cannot be got over and has to be cut. In that case a roll may be put upon the ball from underneath it. Many Americans can do this well.

As to the distance of the player from the ball that differs. Most bad players get too near to the ball; most good players get well away from

it, and keep their arm well away from their body as Mahony does. If, however, one exaggerates this at all, there is a loss of power. R. F. keeps his elbow near his right side, in fact touching his right side.

The position of the feet (see diagram No. 15) is further away from the forward-facing position than in the forehand stroke. The right foot is well forward with the weight on it, though R. F. sometimes makes a backhand stroke with the weight on his left foot. Sometimes, also, the drive with full body-weight lifts up both of the feet.

In order to show how far one draws the racket back before the stroke, we sometimes notice that we hit our left ear as we swing the racket back. We also follow well through, finishing up with the racket high above the right shoulder, the weight being on the right foot.

#### THE HALF-VOLLEY.

The half-volley is a pretty stroke, useful in emergencies, and is apt to catch the opponent unprepared; every now and then an expert like



No. 10.—THE RACKET AT THE BEGINNING OF THE SWING, AS ONE  
WAITS FOR A SMASH.



Caridia uses it effectively. But safe placing is, as a rule, beyond the power of an ordinary player, nor is the half-volley itself safe unless the ground be true (as in the covered courts). In a word, it is a good stroke as an occasional friend, but (like many occasional friends) it is not to be relied on. It is to be avoided when one can make either a ground stroke or a full volley instead. In order to make it successfully, one should turn the body sideways (as for an ordinary stroke), hold the racket firmly, then bring its head through in an upward direction, getting an over-spin on the ball. The weight of the body should be on the right leg when the backhand stroke finishes, on the left leg when the forehand stroke finishes.

#### THE VOLLEY.

It is probable that most players when they get near the net alter their grip, especially in taking a sharp return. All, whether they hold the racket nearer to its face or not, hold it firm and put on less pace, inasmuch as the ball itself has

more pace of its own already. The volley at the net is often a push-stroke rather than a free swing.

Another characteristic of it is that it should be a stroke played down, and not lifted. Therefore the player should be near the net, and not, as many are, just behind the service-line, before the ball begins to fall, for the ball often begins to fall there; and he who stands there is hitting a falling ball—that is to say, is hitting it up to his opponent at the net.

A third point is that the head of the racket should be kept above the level of the wrist, well supported. The Americans are usually weak at the ordinary low volley because they try to take it with the head of the racket below the level of the wrist, instead of stooping with their bodies. (See illustrations Nos. 20 and 21.) One must bend and get well down to the ball. Of course the handle should be held very firmly.

In case the volley is a fairly high one, about the level of one's shoulder, the arm should not be straight, but should be bent at the elbow. For, if the arm is straight, the stroke will be a kind



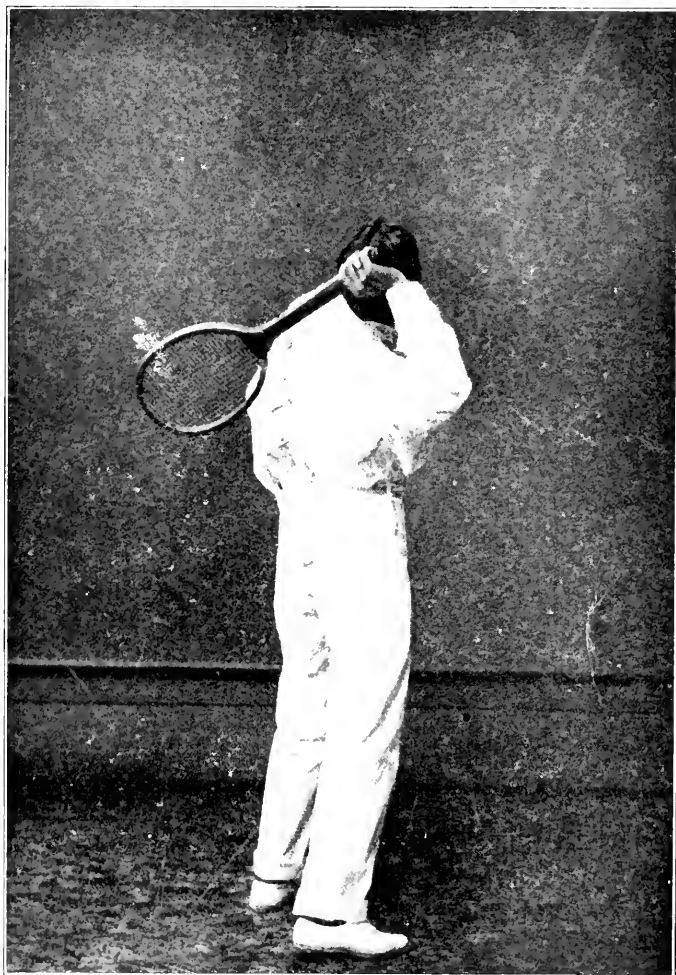

NO. II.—BEFORE SMASHING A BALL.



of round-arm stroke, one which cannot be placed with any accuracy.

In volleying, try to get a good length and some pace on the ball, and do not simply pat it softly back. The length and pace are of importance both in a Single and in a Double.

With regard to the difference between a forehand and backhand volley, although you wait in the same way for each of them (namely, facing the net, with the knees bent, as in illustration No. 19, feet fairly wide apart so that you may move and bend easily, and on the balls of the feet, and with the racket held across the body), when once you know whether it will be a forehand or a backhand volley you must stand differently. For a forehand volley bring the right foot back a little and turn the body slightly sideways, with the weight on the right leg at the beginning of the stroke, but brought on to the left as you come through and bring the weight with your arm. For a backhand volley bring the left foot back a little. The grip for the forehand and backhand will be just as it is for ordinary ground-strokes.

Otherwise the forehand and backhand volleys are very similar: the right position in the court (close to the net), the head of the racket above the wrist (the body stooping, if necessary), the arm bent, the grip firm, an attempt to get some pace and good length—these are the points to be kept in mind, except in the smash, of which we shall speak directly.

#### THE LOB-VOLLEY.

This is a more useful stroke in a Double than in a Single, especially if all four players are up at the net, and you can lob-volley over your opponents' heads. In that case, if you do it well, you generally win the point. But the stroke is a dangerous one, as it must go out of their reach or else it is a certain kill for them. For this stroke hold the racket firmly and with an especially strong wrist; in fact, in this respect treat the stroke like an ordinary volley, but remember that it is better to hit the ball out than to hit it short.

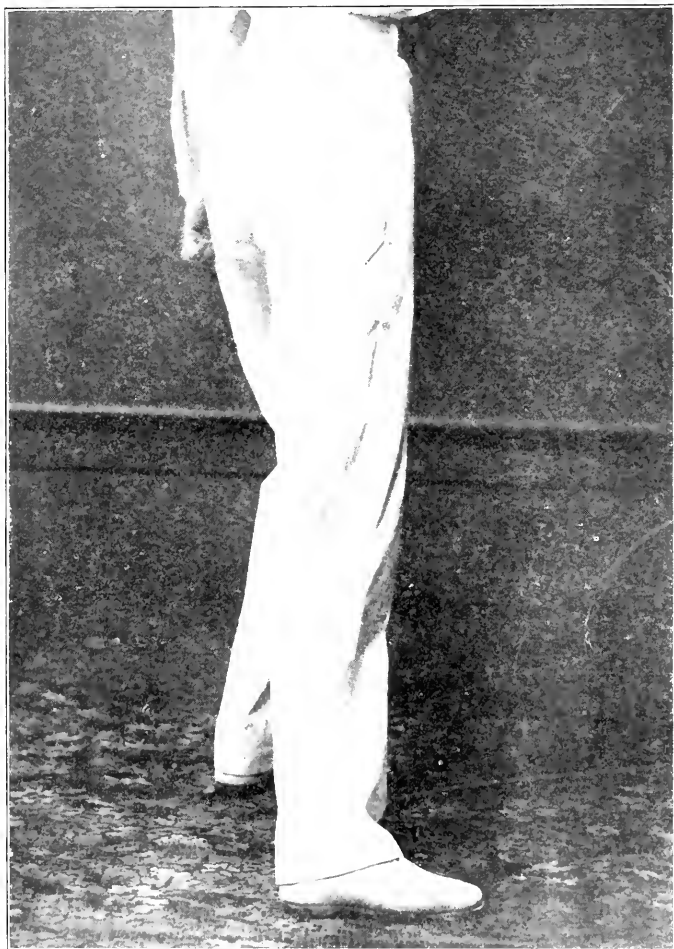

No. 12.—POSITION OF THE FEET FOR A FOREHAND DRIVE.



## THE LOB.

Excessive lobbing spoils the game, but it is not so easy as many imagine. The Americans have studied it carefully. Players like the Wrenns get the length to within a couple of yards, and also the height. Ernest Renshaw was excellent at lobbing.

There are two kinds of lobs. First, that which has to go just over the opponent's head so that he cannot quite touch it. This kind is most useful when he expects to be passed down the side. The second kind goes very high, when you are trying to recover position. The Americans lob far higher than English players.

The low lob, only just high enough to be out of your opponent's reach, must fall within a yard or so of the base-line. It should be used only when the opponent is quite close to the net and expects you to drive the ball past him and not lob, or when he has run to the net for a short ball and cannot get back. It is a hard stroke for him to return by running back, as it bounces

away from him, and not straight up as the high lob does.

The very high lob is among the most useful strokes. It should fall within a yard or so of the base-line. It is best when you are in difficulties, and when you have to return a very hard service in a Double. It gives you time to get out of the difficulty, and to recover your place in the court. It is harder to kill by a smash, for killing is largely a matter of timing and, therefore, of nerve. The higher a ball goes, the harder it is to kill, because there is longer waiting and more chance of nervousness. Besides, the ball falls faster and is more difficult to time.

In making either lob, try to hit it as close to the base-line as is safe. Watch the ball the whole time, as it is essential to strike it with the middle of your racket. The racket does not drive equally all over, and here one must hit hard in order to get the height.

The lob is usually made not with a short and jerked stroke so much as with a back cut, which makes the ball rise faster at first and come down straighter afterwards; but it is better not to rely



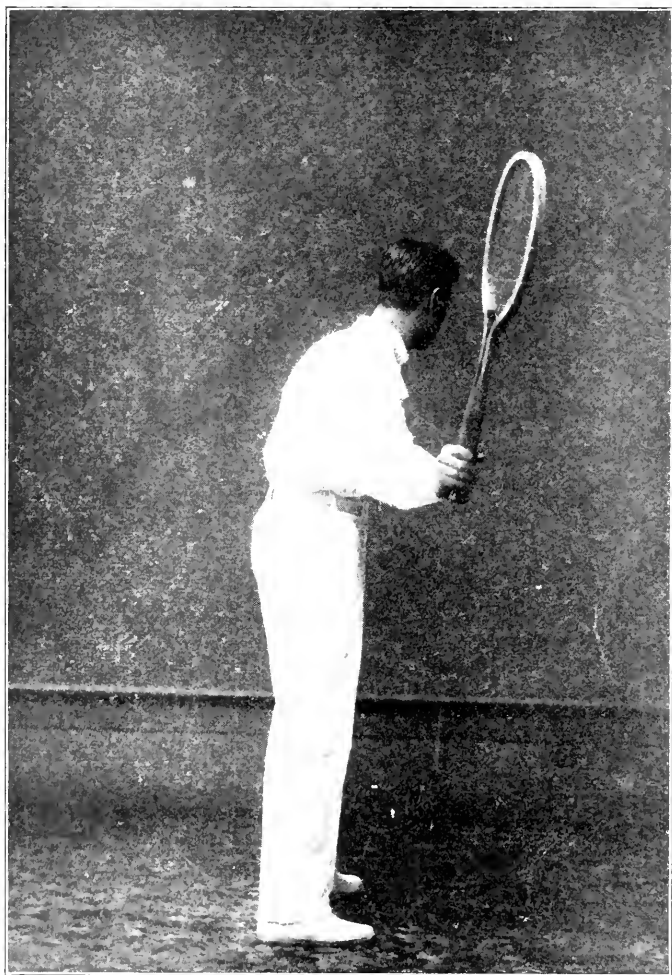

No. 13.—THE SWING BACK FOR A FOREHAND DRIVE.



only on this back cut, but to aim also at good length.

In a Single you should lob to a man's backhand. If he runs round to take it forehand, then he is out of position. In Doubles it is often useful to lob down the middle, or rather to the left of the middle, as your opponents, unless they are accustomed to playing together, will not know which of them should take it.

## CHAPTER II.

## SINGLES.

LET us suppose the strokes to have been mastered, and the habit of keeping the eye on the ball to have been mastered also, so that you can forget the man already at the net or the man running up to the net. Now glue your mind on the game, and forget the score, especially if it is against you. Play up hard for each stroke.

Do not, however, play to kill each ball straight out. A very good lob, for example, you should not try to kill right out of reach, but you should return it by a stroke with fair pace and length, relying on your chance of killing the ball eventually.

There are three ways of playing Singles, differing according to your position in the court.

The first is play from behind the base-line. In

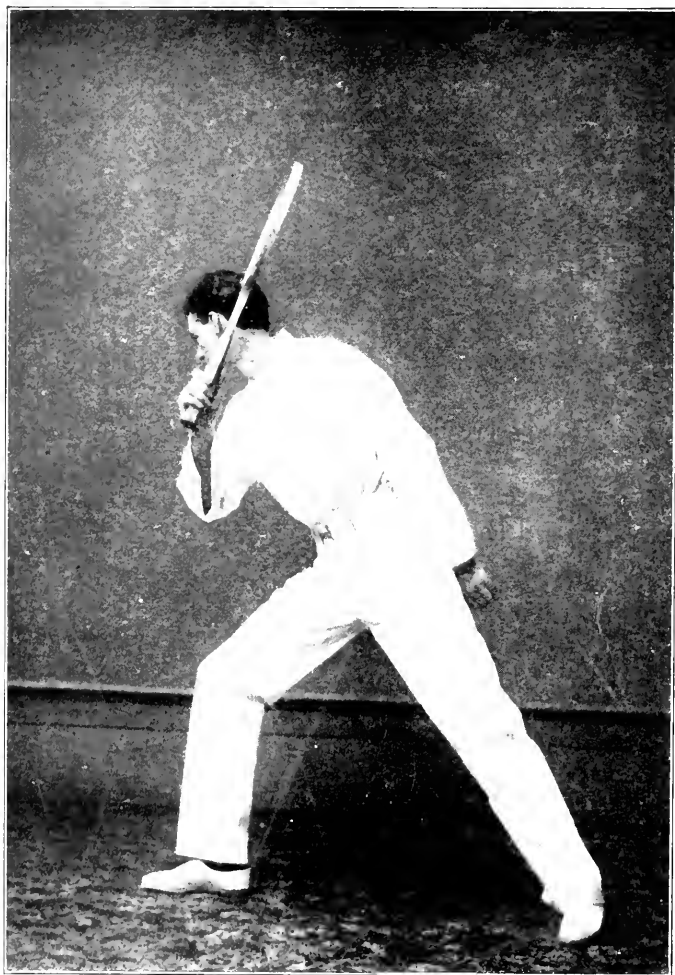

No. 14.—STEPPING INTO THE BACKHAND POSITION



this case, like A. W. Gore, you scarcely ever volley at all.

The second is to run in on your service, and to volley everything. Campbell started this game in America, and the Americans in general adopt it.

The third plan is to play from just behind the base-line until you get your opponent out of position, then to go right up on a good-length drive and volley at the net.

But in all three cases there is this rule, to return to one of the two positions directly after every stroke, the back position being just behind the centre of the base-line, and the forward position being 2 to 4 yards away from the net, but along the centre-line from the net.

There is a third position, which may be called the anticipating position, when your opponent's stroke is practically confined to one or two possibilities.

But anyhow, you must begin to get into position for a stroke in good time, and you must begin to recover from a stroke and get ready for the next in good time also. There are too many players who wait for a long while before they re-

cover themselves and prepare for the return, and so, instead of being quite ready in position when the ball comes, they are still moving into position. If they are moving backwards, their stroke is usually both hurried and weak.

#### THE SERVICE.

As to the service in the Single, little need be added to what we have said about the service in general. If you are not running in, then as a rule it is better to serve right out to the side, so as to get your man out of position. This is not always a good plan when you are running in, as it gives him more room to pass you. The pace of your service will depend largely upon whether you mean to run in or not. If you mean to run in, then it will probably be better to serve slower and higher and with more drag.

#### THE RETURN OF THE SERVICE.

There are several ways of returning the service. You can drive down the side-line, or make a stroke down the middle line, or a stroke across the court. The lob should be used very seldom as



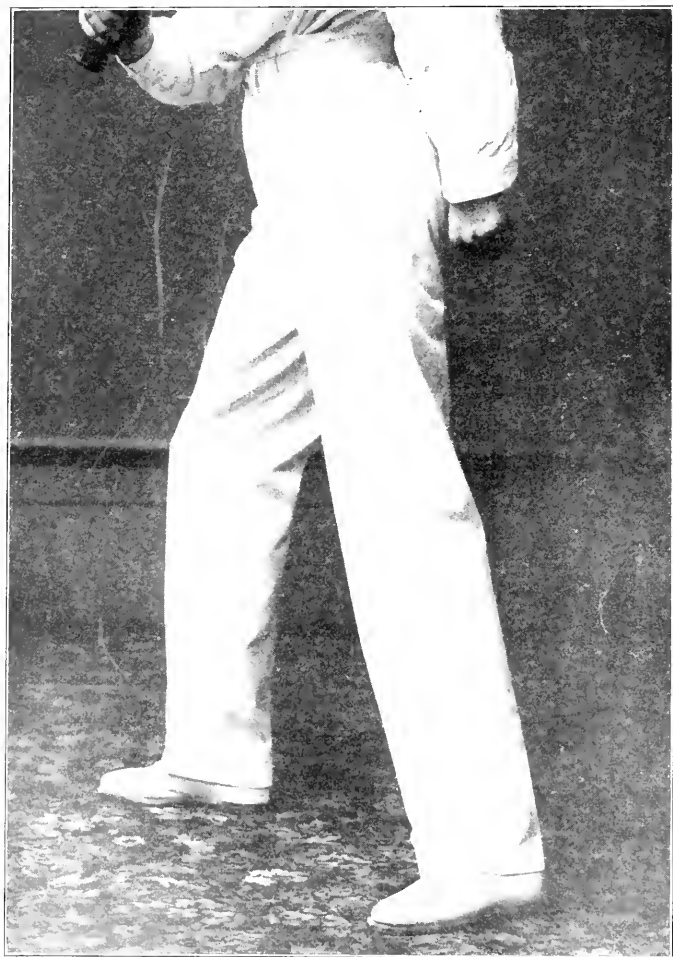

No. 15.—POSITION OF THE FEET FOR A BACKHAND DRIVE.



a return in the Single. In the Single, moreover, it is not so necessary to hit the ball as low as you should in a Double, unless your opponent is running in, and even then it is not necessary to hit so low if you can place well; good length is far more important.

If you are playing from the right court, the most effective return is to drive down the side-line to your opponent's backhand. Then you can come up to volley his return. But it is a great thing to vary your direction and pace, &c.

If you are playing from the left court, the most effective return is a drive across the court, not too short, but a good-length stroke near the side-line. If the man runs in on his service it often pays better to play a slow return low over the net, either down the line or across, than to try to hit the ball hard past him, for he will have to take your slow return while it is dropping, and therefore hit it up in the air, in which case you will often be able to pass him. But while taking the service keep your eye on the ball, and utterly ignore the man who is running up to the net.

## PLACING AND PASSING.

This same rule applies to all occasions during the rally. You must not look to see where your opponent is.

The return should be varied, just as the service should be varied, with respect to pace and place. The unexpected is invaluable. As to placing, the Americans study accuracy of length rather than accuracy of direction; and on the whole their length is better than ours, while our direction is better than theirs. But some day they will probably add the direction also, for they are studying every item of play and tactics most carefully and thoroughly.

## THE LOB.

Here, again, little need be added to what we have said about the lob in general. It is useful when you are in difficulties, and especially when your opponent is at the net. In that case it is safest to lob, and lob high; for it is harder for your opponent to kill a high lob or overhead vol-



No. 16.—BACKHAND DRIVE, TOP HAVING BEEN PUT ON THE BALL.



ley by a smash, and you have more time to recover your position. A good low lob is useful if you can send it just over his head when he is very close to the net and not expecting to be lobbed over. In the case of both kinds, the lob to the backhand is more effective than to the forehand, because it is harder to kill.

#### VOLLEYING.

Here we need only repeat that in a Single it is a great mistake to volley short, unless you volley right across the court. You should rather try to get a good length and some pace. If you simply pat you will probably be passed. All the general rules given for volleying (see Chapter I.) apply here.

## CHAPTER III.

## DOUBLES AND MIXED DOUBLES.

## (1) DOUBLES.

## GENERAL REMARKS.

DOUBLES are not like Singles. In Doubles you are no longer a unit playing for yourself against one opponent; you are only half a unit against two partners or would-be partners, with a gap between them—a weak middle.

Quite apart from the mental difference, the larger number of things to watch, there is the difference of strokes, most noticeable of which is the stroke down the middle, and, more generally speaking, into the intervals between the opposing pair. Besides this, the Double needs lower hitting over the net than the Single does, and needs considerably more lobbing. If you get a good



length high lob, and your opponents are not good at killing, both you and your partner should run up to the net.

In the Doubles there is considerably more volleying, and it might be asked whether you should alter the grip of your racket because of this extra play near to the net. All the best players do, except one or two; but the Baddeleys never did. You should not grip the racket nearer the face in volleying than in making the ordinary strokes; you should never grip the racket higher up than an inch from the end.

#### THE TWO AS A PAIR.

The two players should learn to work together, or at least should have some clear understanding as to which is to take this or that kind of ball. Yet part of the skill of Lawn Tennis is to adapt oneself not only to a new opponent but also to a new partner.

When both you and your partner are at the net, you should be parallel and work as one great wide man, but as a man of the same width consistently, not like a concertina, now wider and

now narrower. If you are driven to the left, your partner should move to the left also, so that he may cover you, or else he will leave too large a space between himself and you, down which the ball may be hit.

When a lob has been sent by your opponents, do not let it drop if you can help it, unless you think it is going out. But, if you must let it bounce, then it is best to lob it back again and to lob it very high. Meanwhile your partner, directly he sees that you will let it drop, should get to the back of the court.

If you have returned the lob without letting it bounce, get to the net again as soon as you can, with your partner; in fact, generally try to work up towards the net, and to put your opponents on the defensive. Make your opponents volley up; be yourself always in the position to hit down.

#### LOBBING.

Enough has been said already about lobbing. Here we need only remark that the higher it is the better, so long as the length is good.

When you are taking a lob, if it is a very good



No. 17.—FINISH OF BACKHAND DRIVE.



one, hit it to the man who is further from the net; if it is any other than a good one, hit to the man nearer to the net.

And now as to the players considered as (1) the server; (2) the server's partner; (3) the receiver; (4) the receiver's partner.

(1) THE SERVER.—Many of the general remarks about serving will apply here. After serving, the player should run to the net always and get as near as possible to it without actually sprinting. If he sprints he is not so well-balanced and is not so steady, and therefore cannot make so good a stroke and will sometimes get lobbed over. Whereas in a Single he cannot always decide whether he had better run up to the net or not, in a Double he should always run up after his service.

You as the server should take all balls that come down the centre or across the court, and all lobs over your own head, but not those over your partner's—that is to say, if he understands the game—for these he should get for himself.

(2) THE SERVER'S PARTNER should stand about 4 feet from the net, though rather further off if the server's second service be weak. He should stand a little nearer to the side-line than to the centre-line.

While one's partner is serving, what should one look out for, what strokes should one try to take? The server's partner should not look round at the server when he is serving. First of all, there are the strokes directly down his own side-line; then there are easy strokes near the centre of the net. These he should be prepared to step across and kill. But he must not be too eager to jump across in this way—the weaker the player is, the more eager he seems to jump across for the return of the service which his partner could take just as well—lest he should be unready for a stroke down his own side-line or a lob over his head. He may run a greater risk if his partner has a hard service.

Anyhow, you should take all lobs that come on your side and not leave them for your partner. You must get them if you can before they drop, for it is usually fatal to let them drop when play-

ing against a good pair; and therefore you must be able to run back well. If you leave them to the server, he will not dare to run up to the net; he will be hesitating between guarding his own side and taking the lobs which you leave alone.

(3) THE RECEIVER OF THE SERVICE should try to return the ball low over the net, or else lob. Then—this is one of the hardest parts of the Double, and one of the reasons why the server has such an advantage—he should work up towards the net as soon as possible.

As to his low return, it should be down the side, especially if the service be hit to the side and bound out of court. This stroke, however, is dangerous if it is not well placed, and if it is hit rather high. But it is a good one to use occasionally so as to keep the partner from guarding the centre too well and coming across out of his own court.

But the stroke down the centre of the court is easiest, and when low is very paying.

Another paying stroke is the stroke across the court quite low down, to drop near to the side-

line. This is the best, but perhaps the hardest, because the server can only just reach it, and is forced to hit it up. It is hard for him to pass the receiver's partner down the side, and he is almost bound to make a cross-return. Then the receiver's partner should step across and kill that cross-return.

If the service be very hard, however, the lob may be best.

When you have returned this service (say out of the right court) low across the court or down the middle, and the server has, as he usually does, volleyed it back to you with a fairly good length, a very paying stroke for you now to make will be a drive right short across the court; but it must always be kept low. This stroke is an excellent one to make two or three times at the beginning of a match and every now and then during it, for it makes the server or man who served be prepared for your passing him across, and he is not so ready to get back if lobbed, and he also leaves more room down the middle, which, if his partner tries to cover it, must leave his sideline more at your mercy than otherwise would



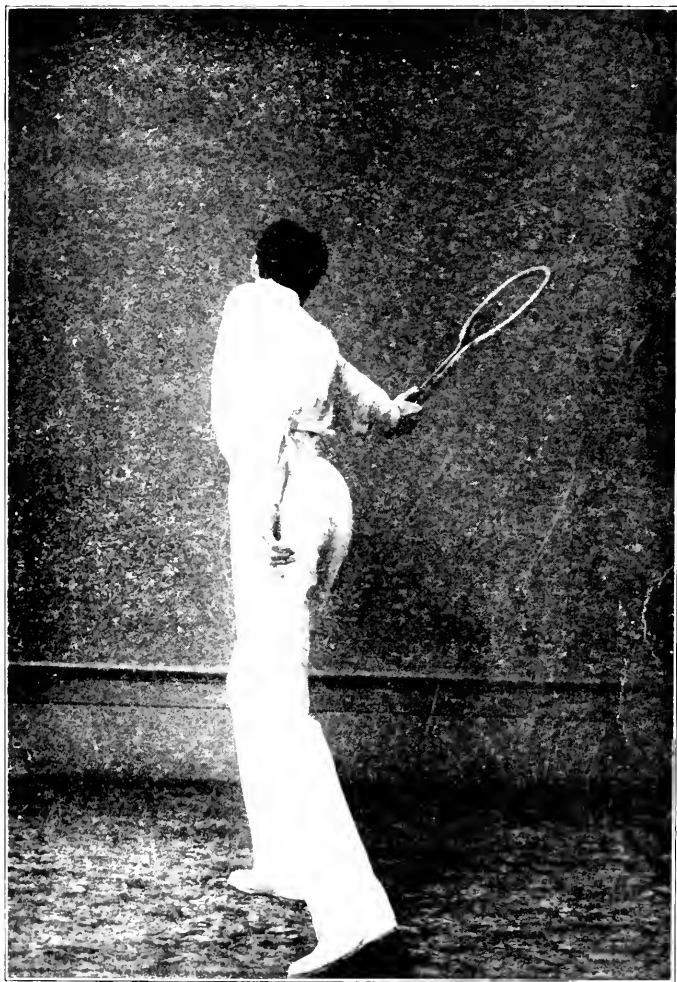

NO. 18.—THE FINISH OF A BACKHAND DRIVE ACROSS  
THE COURT.



be the case. (We think it is a good stroke to go for, even if it does not come off.) If the server volleys your return back with a very good length the best thing to do is to lob. (The cross-stroke applies to the left court as to the right.) The Americans nearly always return the service thus in the Double. You should not try to hit just over a man's head off a hard service, as it is too difficult, but you should hit a high and good-length stroke. As a rule, the higher the lob the better.

But variety is vital, and occasionally one should hit a slow service straight at the man at the net.

(4) THE RECEIVER'S PARTNER.—It is a question where the receiver's partner should stand when the service is being sent. Much depends on the nature of the service which the other has to take. If the service is fairly hard and, indeed, for all second services, he should stand between the net and the service-line. If, however, the server has a very hard service, he should stand about a yard behind the base-line.

If he is up, and if his partner makes a good low return, then he may be able to kill the next stroke. If he is back, as the Americans usually are, and if his partner makes a weak high return, he will have more time and chance to get it; whereas, if he were at the net it would probably be hit down at his feet.

Two more general remarks on Double play may be of use.

When all four players are at the net and your partner is volleying backwards and forwards, do not watch him, but the ball, as if it were yourself who had volleyed, and then you will be ready if the ball is suddenly hit at you.

Never get cross with your partner, but if he is "off" and playing badly, cheer him up, as it may be only want of nerve that is putting him off, and if he sees that you are annoyed it will make him worse.

## (2) MIXED DOUBLES.

Mixed doubles are perhaps more beloved by ladies than by men, partly because one man hates to hit so many balls to the opposing lady and the

other man hates so many balls to be hit to his partner-lady. Yet in a match a man must not mind sending a good many returns to the lady, if only we except smashes, since he is in honour bound to try to win for his partner's sake.

Apart from the American type, in which the woman stands at the net and the man jumps around, there are two important classes of Mixed Doubles. In the first, both players volley, somewhat as in men's Doubles; in the second, the girl is at the base-line while her partner dodges about, usually near the net, trying to kill as many returns as possible. A variety of play is seen when both players are standing back. This game may be dismissed at once with the advice that the man should take balls when there is doubt.

The first game, in which both players volley at the net, is the prettier game and also the pleasanter to play. But very few girls can volley well enough to be safe up at the net, and unless they are really good volleyers they are much better at the back of the court, leaving their partners to do the net-work. We shall say most about this game

here, because least has been said about it in other books.

When the man is serving, the girl, his partner, stands close up to the net, the closer the better, and the man follows up his service. The girl should content herself with taking all balls hit down her side-line, or straight at her, or over her head if they are weak lobs. The man must take all the middle balls, all balls straight across, and most of the lobs.

When the girl is serving, her partner should stand up at the net ready to run across in case he gets a chance of killing a return. He may come back if the man-opponent has a very hard return of the service, but as a rule he should be up at the net. The girl should not run in on her service, unless she is a very good volleyer.

Where the girl should stand when her partner is receiving the service depends on many things. If the opponent has a hard first service, she had better stand behind the base-line. She should stand here also if her partner has rather a weak return. Otherwise she should be at the net when the girl is returning the service. Where the man

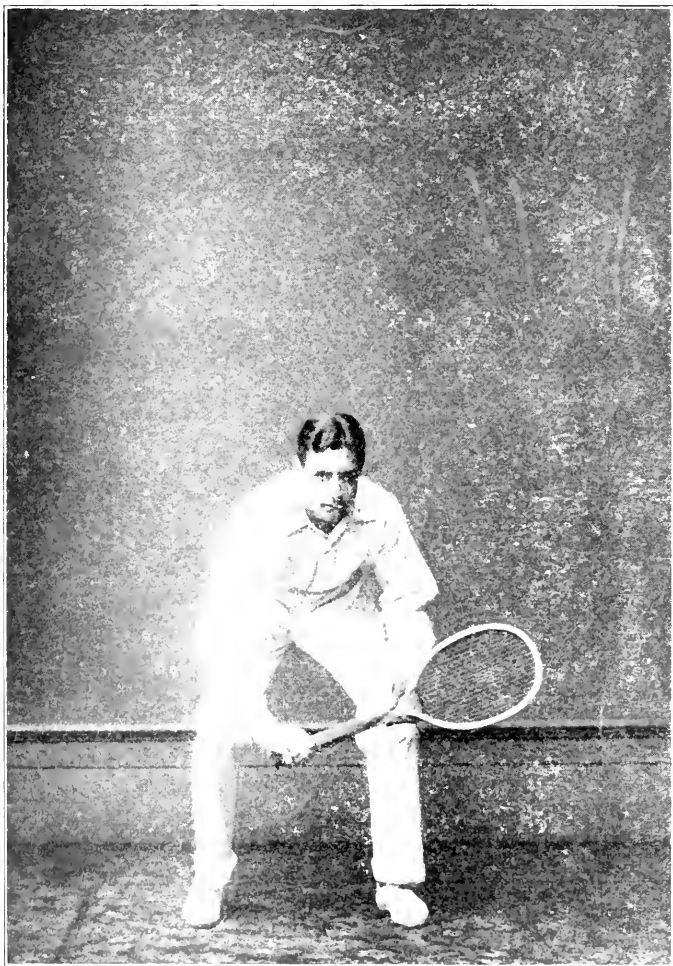

No 19.—POSITION AS ONE WAITS FOR A VOLLEY AT THE NET.





should stand depends on his partner's power of return. If she is weak, he had better be back; otherwise he should stand just inside the service-line.

When both the girl and the man are up at the net volleying, the girl ought to be closer to the net than the man is, as the man must be ready to run back and smash the lobs. Also, if the girl is further away than the man, or even level with him, she will get more work. If she is close up they will not hit at her so much, in case she may kill the ball. We notice how, in men's Doubles, the man further from the net generally gets more work than his partner. When both the man and the girl are up, the girl should be from 1 to 2 or  $2\frac{1}{2}$  yards, the man from 4 to  $4\frac{1}{2}$  yards from the net.

As to the second kind of Mixed Doubles, when the man is serving from the right court his partner should stand just outside the base-line, well to the left of centre of the left court, so as to cover her backhand, which is nearly always the weak stroke of girls. The man should as a rule follow up his service.

When the girl is serving, the man should al-

ways stay up at the net if the girl-opponent is returning the service, and he should be ready to run across if he gets a chance of killing the return. If the man-opponent has a hard return, he may sometimes be wise to stand back.

The other positions should be as in the first kind of Mixed Doubles, only the girl should always be back. The man should every now and then run across and volley, especially the girl's returns, partly because it is so much easier to tell where the girl is placing her stroke than where the man is placing his. His girl-partner must not mind if he does miss a few or get passed, but he should not risk too much. It may baulk a girl if her opponent is always dodging about at the net, because girls when they are going to hit the ball generally take their eye off the ball to look where the man is, and what he is doing; hence they either miss the ball or hit it straight at the man. If the man-opponent is getting too near to the net and is running across a great deal, his girl-partner should lob, and should not mind risking hitting a few out.

The lob is one of the most important strokes

for the girl to be good at in Mixed Doubles, and indeed in Singles also; in fact, a girl cannot really be good at Mixed Doubles unless she can lob.

## CHAPTER IV.

## HINTS ON PRACTICE, TRAINING, AND MATCH PLAY.

## (1) PRACTICE AND TRAINING.

SOME players are content with a couple of weeks' practice. W. Renshaw was one of these. Smith requires two months, and so do players like the Allens. Among the best kinds of practice is the tournament, for it helps you to observe that vital law of practice—never to play slackly.

The test of when you should stop practice is the interest and keenness on the play. Staleness is to a great extent due to play when one is slack.

A few exercises for beginners may be of use :

The beginner should learn to be quick on his feet : for example, to run back quickly in order to smash a ball.

For the smash, as well as for the service, he should get his right shoulder well down, his trunk

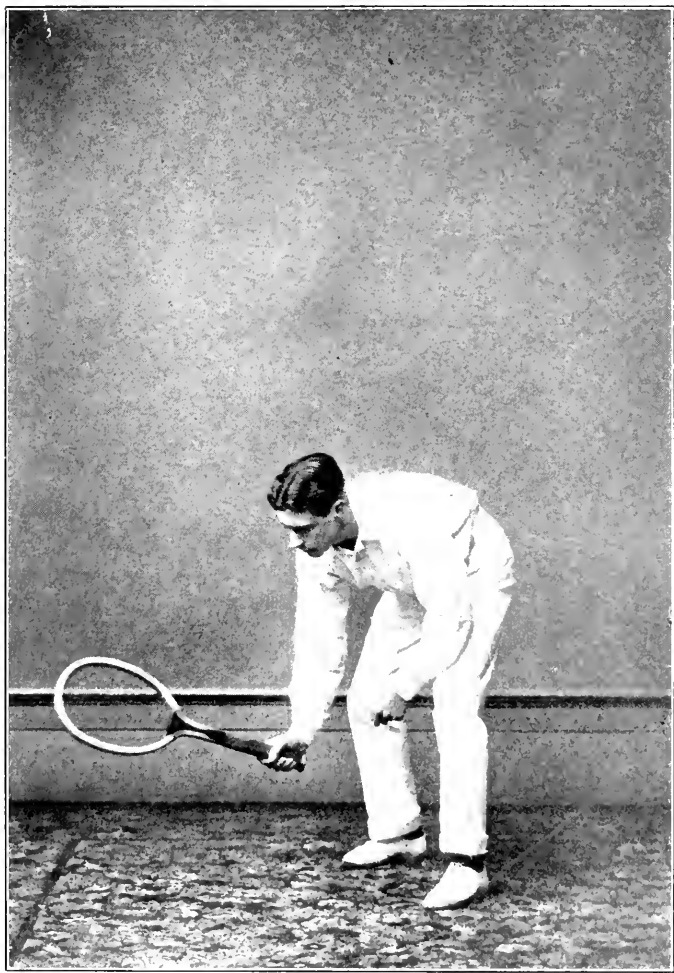

No. 20.—LOW FOREHAND VOLLEY.



bent back, and his head up, with his eye on the ball. Then he should give a full swing with the body and carry through his racket so that it ends up near his left knee. He should not lose his poise, but after his service he should be prepared to run in immediately.

From the waiting position, which is shown in the illustration, he should be able to pass easily into the forehand position, make a free swinging stroke with a full follow-through in this position, then recover himself and return to the waiting position. From the waiting position he may pass to the backhand position similarly.

With regard to details, he should familiarize himself with the correct grip and the change of grip. He should strengthen his wrist; he should, if he has the opportunity, practise the commonest strokes up against a wall, taking care to face sideways, for this is one of the great secrets of a good swinging stroke.

## (2) MATCH PLAY.

It is well to knock up for a few minutes before a match, so as to get your eye in. The Americans

generally practise for ten minutes. This is right if you are a bad starter.

But when once the match has begun, then you must go as hard as you can from start to finish. You should never slack off if you are ahead, else, especially after playing your hardest, you are most likely to go to pieces and be unable to play up again when you wish to. But, on the other hand, when you are behind, you should never give up; you should ignore the score and try for every stroke as it comes. Remember that hundreds of matches have been won after coming within a single point of being lost. Play your best game, whatever the score may be. The man who sticks to it, and tries for every single point, will often beat a player who is otherwise half-fifteen better.

Above all, never let the mistakes of an umpire or linesman put you off. Think of nothing but the game; no one can play satisfactorily except with his whole mind on the game. Let there be no hurry and no flurry.

If you lose the first few games, do not get frightened and play softly, as a number of players do. This panic is one of the reasons why so many



play better in practice than in matches. There is as great a difference between a Single practice game and a Single match as there is between a Single and a Double. People should play practice games with the same keenness with which they play matches; they should play matches with the same calmness with which they play practice games. This applies only to the spirit of calmness, and not to the general tactics. In a match you should use your head, and try to find out your opponent's weak points and play to these. You should try to avoid your own weak points. In practice this would be bad advice. Here you should try to strengthen your own weak points.

Before you play a match, do not think about it. While you are playing it, unless you are dry and the weather is very hot, do not drink. If you must drink, take some simple drink like oatmeal-water or tea.

## CHAPTER V.

BRIEF NOTES FOR BEGINNERS, WITH A LIST OF COMMON FAULTS.

ANYONE who is starting to play the game should get a good racket, balls, boots or shoes, etc. It never pays to get cheap things at a bazaar; it is far better to go to a good place and incur a little more expense at the beginning by getting the best bats, balls, and so on, and thus start under good conditions. The clothing should, of course, be such as will not in any way cramp free running and hitting.

Then the player should learn how to hold the racket. This is most important. For if he starts, as many do, by holding it in some manner which seems ordinary to him but is extraordinary to one who wishes to succeed and who knows the

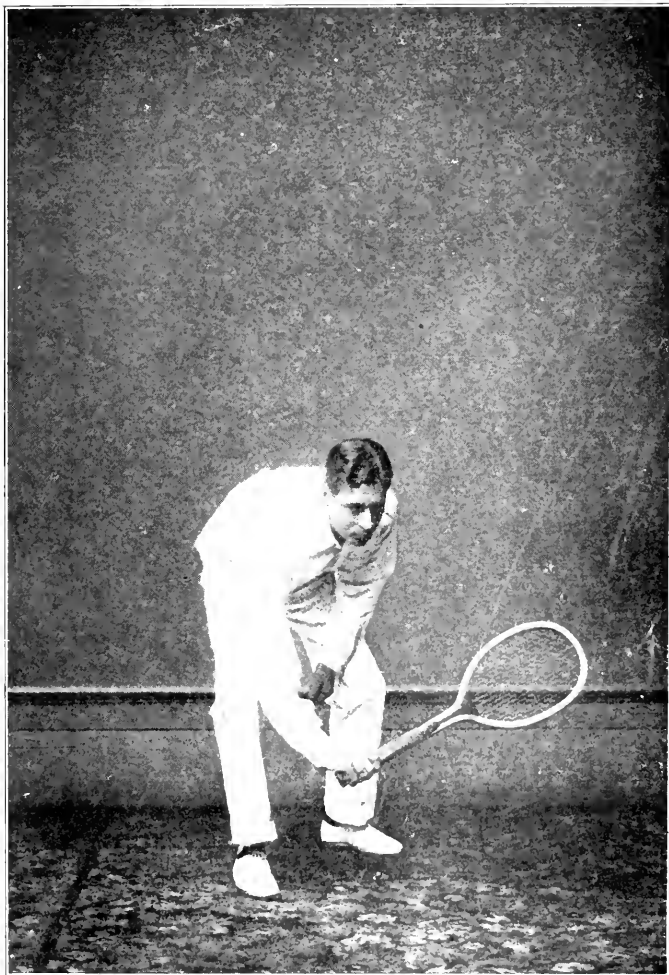

No. 21.—LOW BACKHAND VOLLEY.



reasons for things, he will get a bad style. Style, which was once defined as "the easiest way of doing a given thing successfully," depends a great deal upon how the racket is held. Besides, if one starts with the wrong grip, it will take some time to get out of the habit. Players who have played for years, and who have reached a certain standard, chiefly by sheer practice, and who hold their racket in the wrong way, would do well to learn a better way and then practise it. Of course at first they will play much worse when holding it correctly than they did when holding it in the old familiar way, but having once become used to the new grip they will rapidly improve.

Begin as early as you can to master this and other essentials of style.

Beginners should be content with playing off the ground at first, and should not try to volley. They should not try to hit very hard either, but should aim at a good length and accurate direction. After every stroke they should return to a spot a yard behind the base-line. It may encourage them to know that R. F. is not quick at

actual running, but is quick at returning to his proper position.

Beginners should try to judge where the ball will strike the ground, and then where it will be when it is at its proper height for their stroke, so that they may be at the right distance from it. It is better for them to be too far from it than too near to it, as it is easier to run forwards than backwards, and it is also easier to make a good stroke when one is running forwards than when one is running backwards.

Though we tell the beginner to aim at good length and accurate direction before he hits as hard as he can, yet it is a mistake for him merely to pat the ball. He should always meet the ball instead of letting it meet him, and he should bring the head of the racket right through.

Practise the ideal strokes, whatever they are, and in games and matches get as near to them as you can. Part of the ideal stroke is to have the body well round, and not facing forwards; to play with the body, and not only with the wrist; to keep away from the ball but not too far away; to make a stroke that meets the ball squarely so

as to add pace, a stroke that meets the ball and does not let it meet the racket, a stroke that gets over the ball, and follows through in the direction in which one wishes to hit the ball—these are some of the golden rules for the general stroke.

As to service, get a moderately good first serve as nearly a certainty rather than a very fast first serve as a mere possibility. Make your opponent move to take your service; try to get him out of position.

This is the secret of tactics, to get your opponent out of position, while you yourself return to position as soon as possible after your stroke.

Try to make your opponent hit the ball up so that you may kill it by hitting it down.

When you are in difficulties lob high.

Anticipate your opponent's stroke if you can safely do so. Much depends on observation of what most players usually do, and much on a certain innate genius.

In the Double, keep on a level with your partner or else return to the level, and with him work up gradually towards the net.

## SOME COMMON FAULTS.

The commonest fault is to start wrongly and get a bad habit. We shall here omit details with which we have dealt before. For instance, you should avoid too severe a first service; you should try a new service occasionally, since it may suit you. Leaving out such points, we must come to the fundamentals, and the first of these is the one mentioned just now—the grip.

It is probable that a grip which is good for a forehand stroke may be bad for a backhand stroke. It is probable that most players will find a change of grip advisable. A bad grip is by itself a sufficient cause for an unsatisfactory stroke.

Then there is the wrong position of the feet, and especially the position when they face the net too much, instead of facing the side to which the ball is coming. Or a player may be getting too near to the ball so that he loses power, or he may fail to return to his proper waiting position after the stroke. He may be content with having made the stroke, forgetting that



another is to follow immediately. This may be due to sleepiness of mind or to stiffness of body, or to loss of poise.

Not only is the position of the body often at fault, but the position in the court itself is responsible for a number of mistakes. A stroke which would be easy if the player were down the centre-line, either near the net or outside the base-line, becomes hard if the player is caught between the service-line and the base-line, the very worst position for most players.

Another common fault is to take the eye off the ball, and particularly to let the eye fall on the opponent if he is at the net.

It is a mistake not to have a variety of play; one should not practise too much with the same player, unless he is very good all round.

As to the double game, out of all the faults we have included in the above remarks we may take out this one in particular—that a player very often fails to understand how much ground he should cover, and is apt to get too near to his partner or too far from him or else out of the parallel line.

## CHAPTER VI.

OUR IMPRESSIONS OF PLAY AND PLAYERS IN  
AMERICA.

LADIES do not play at any of the big tournaments in America, but in small garden-tournaments they play Mixed Doubles and Ladies' Singles, and also have a championship tournament of their own. This seems a better arrangement than for the two sexes to play at the same tournaments. Mixed Doubles are not much liked, or perhaps it would be safer to say they are not taken very seriously by the American men players. Ladies at Lawn Tennis there are looked on as Englishwomen at Cricket here. Bigger crowds go to see matches, and are ever so much keener about the game.

The play of American men is quite unlike ours, though equal to ours in point of skill. If the

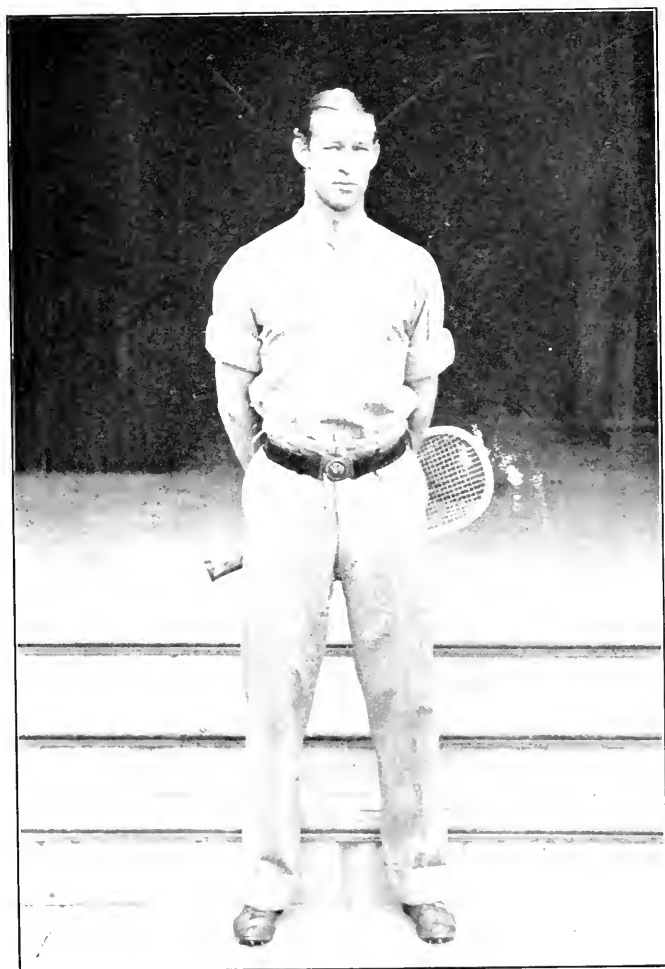

No. 22.—W. A. LARNED, CHAMPION OF THE UNITED STATES  
1901—1902.



twelve best players of one country played against the twelve best players of the other, it would be very hard indeed to say which would win. The American conditions, except for the great heat, are quite up to ours; and one could not wish to have better courts than those at Brookline near Boston, or at Newport, on which the championships were played, or at the Athletic Club, Bay Ridge, near New York, on which the International matches were played, and which are quite perfect. The courts at Southampton were better than the ordinary courts which one gets at an English seaside resort. Moreover, all the Americans we played against were delightful men to meet and oppose, and thorough sportsmen; and the gallery, taken as a whole, were sportsmanlike also, and ready to applaud good strokes, whether they were made by Englishmen or Americans.

But the umpires and linesmen are not nearly severe enough to people who foot-fault. They rarely call "fault" at all when a server steps into the court while serving a ball. They will call "fault" at once when anyone's left toe touches the line; this is, of course, not nearly so important.

The Americans themselves say that the excessive running in on the service rather spoils the game, and that the server has too great an advantage. The advantage would be much smaller if every time a foot-fault were made it were called. And this applies to both first and second services. The linesman will often fault a man on his first service, but he does not like to do it on the second as it will lose him the point. A good law, and one worth considering by those in authority, would be that if a man made a foot-fault at all he should lose the whole stroke, whether the foot-fault were made on the first or second service.

The ideas of most English people about American players are based chiefly on what they have seen of Davis and Ward. Now Davis and Ward are exceptional. There are no other two players like them in America. The two Wrenns, for example, play quite a different game, going in for safety and lobbing the return of the service. But still, perhaps, one might decide that on the whole the Americans were more brilliant in one sense. What strikes one first of all in their play is that it is very ingenious. The American may be said to

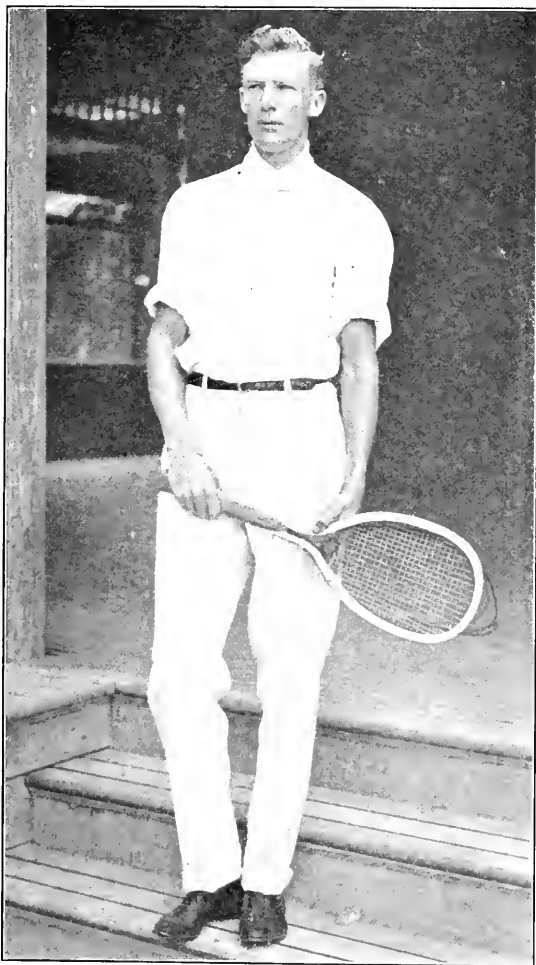

No. 23.—M. D. WHITMAN, CHAMPION OF THE UNITED STATES 1898, 1899 1900.





make it almost his entire aim to win. He does not care much how the stroke is accomplished so long as it scores, and who shall say this is not correct?

Certainly the American game is, if not more brilliant, at any rate more aggressive than ours; even the lob is often used for attack and not merely for defence. There is in the American stroke a greater show of pace. We may doubt whether there is more real pace, and whether most of it is not apparent rather than real; but certainly the players get rather more top on their drives.

Even the most obvious exception, the service, which is slower, has as its object to enable the server to get to the net by running in on everything. The server usually serves down the centre-line, so as not to give his opponent too much room to pass him. When at the back of the court the American is very good at getting to the net after his drive; indeed, while we repeat that we doubt whether his stroke itself has more pace than ours, we can hardly doubt that he is quicker at running up after he has made his drive. Americans one and all, with perhaps a

single exception (Stevens), make it their supreme object to get in as close to the net as they can. If we can speak of such a thing as American tactics in general, we must include this.

And certainly the plan pays, because the Americans volley so well overhead. On the whole, they are better at smashing lobs than the English are.

In fact, they have brought to great perfection at least three points: first, the run in on the service, and the kind of service on which one can run in, so that they manage to get in close before the ball has returned; secondly, overhead play; and, thirdly, lobbing. On the whole, they lob higher than we do.

On the other hand, the Americans, except Beals Wright, are bad on the low volley, especially in Doubles. They are less accurate in direction, though not in length; they have less "follow-through"; they have less gracefulness of style.

But they have more seriousness in this as in everything that they do. Perhaps they do not practise so much more than we do, but they take more interest in their practice and in their play.

The game is played more at the 'Varsities; the players train more thoroughly.

If anyone had seen a great deal both of English and of American play, he might say that the first-class players in America reached greater heights and also occasionally touched lower depths than the first-class players in England.

Coming now to individuals, in Singles we should without hesitation say that the two best players are Whitman and Larned, though we might doubt which of the two would win. Perhaps Whitman would win more consistently and oftener, though it is possible that Larned might beat him quite easily on his day.

*Whitman* is very safe everywhere, and has not a weak point. We believe he has only been beaten once in the last five years. Perhaps his backhand is almost as good as his forehand. He plays the volleying game, as nearly all the Americans do, and gets up to the net on every possible occasion, and when at the net is very hard to pass. He is wonderfully sure on his volley and, besides, has an enormous reach, and is very active and severe overhead. Off the ground he plays

rather a soft but still an accurate game, and gets more pace on the ball than he seems to. His length is always excellent. He hits the ball rather low, and passes well. And he has that supreme merit—that he rarely misses easy strokes. His weakest point is the weakest point of nearly all Americans—the low volley. His twist service is a little puzzling, though not really as difficult as that of either Davis or Ward. It is good for running in on, and its reverse twist makes it hang in the air, and also makes it very hard for the opponent to place. Whitman uses his head all the time, and his game is carefully thought out.

*Larned*, when on his game, is very fine indeed and very brilliant. His is a good style and pleasant to watch. Throughout he hits hard, and goes for his stroke. With very little effort Larned gets great pace on the ball. His forehand is distinctly stronger than his backhand, but he puts top on both, hitting nearly at the height of the bound. Among his strongest points are his forehand volley, which is very hard indeed, and his service, which is a capital one of the ordinary

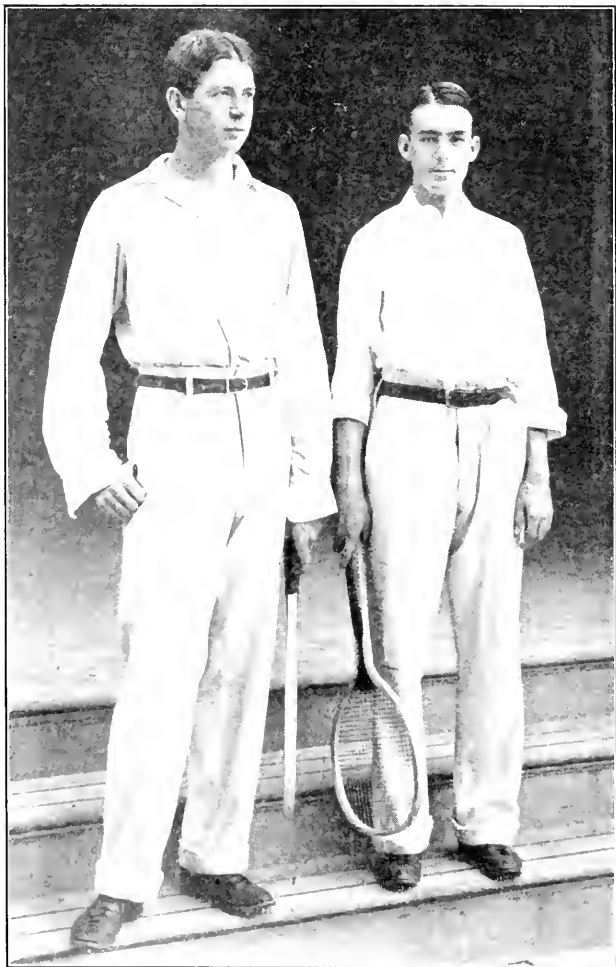

No. 21.—D. F. DAVIS AND H. WARD.

The American Team that Played Against England in Doubles, 1900.



straight kind, and which he, as a rule, follows up to the net. He is quick at reaching the net after a good length drive, and he can drive the ball while he is on the run. He is good at the volley, but erratic at times in his return of the service. He has really only one fault—namely, that he varies at times; he has his off-days.

*Beals Wright* is certainly the best in America at low volleys, and is very good overhead. His volleying is distinctly superior to his ground strokes, and his forehand is somewhat stronger than his backhand. He has a good service, which he follows up to the net.

*Clothier* has copied Whitman, but is not so good. His twist service is much the same as Whitman's, and he always follows it up to the net. He volleys well, and is especially severe overhead. His volleying is considerably superior to his ground strokes.

*Ware* is a very pretty player, an all-round player with a good style. His forehand, backhand, and volley are all good. He should improve a great deal with practice.

In *Doubles* there are two very fine pairs, Davis

and Ward and the Wrenns. It is hard to say which is the stronger pair, though perhaps the verdict might be given for Davis and Ward. In style no two pairs could be more different, Davis and Ward being unlike any other pair anywhere, if only because of their extraordinary severity; the Wrenns being more like the Baddeleys, wonderfully safe, and missing very few easy strokes.

The *Wrenns* lob the service oftener than the *Baddeleys* did. Their own service is not severe, but they get in on it very close to the net, and are good at close volleying. Their strongest point is their lobbing; they lob very high and with splendid length. Overhead they are safe, though not severe. One does not get any change by lobbing to them. They have any amount of return, and are very active as well as patient.

*Davis* and *Ward*, as we have said, play a game quite their own. Both serve the American twist service, and serve it better than anyone else. They sometimes stand in the same court: when *Ward* is serving out of the right court, *Davis* also stands in the right court up at the net. *Ward's* service curves in the air to the right, and when it



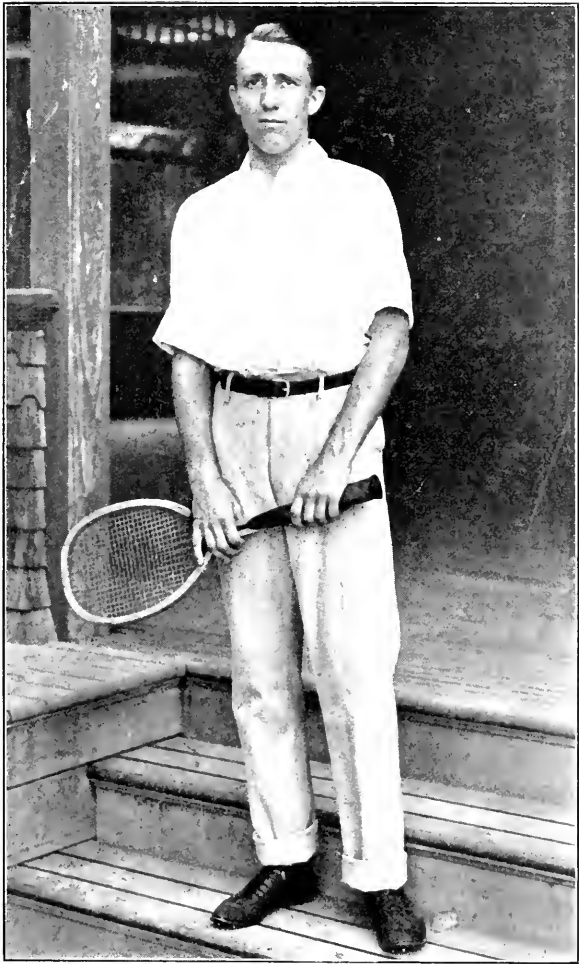

No. 25.—ROBT. D. WRENN.



strikes the ground bounds to the left. (Davis is left-handed, so his service does just the reverse.) Ward's service has so much twist on it that if one tries to hit down the line to Ward as he runs in on it, the ball will go across the court to Davis who is there waiting to kill it. They both lob very frequently while returning the service, varying this stroke, however, by hard drives across the court. Their lob is like the Wrenns'—high and good. Both are brilliant, and go for their stroke nearly every time, especially Davis, who kills lobs harder than anyone else who has ever played the game. Their volley is altogether very severe.

## CHAPTER VII.

## LADIES' PLAY.

BY MISS TOUPIE LOWTHER.

IT is curious to note what a marked inferiority there is in the ladies' game as compared to the men's, if one takes the best representatives of both sexes. Allowing a handicap of even as much as 15 for skirts and ladies' dress in general, still men's greater strength and activity will ever give them a very decided superiority over any woman.

As regards this question of dress, I think it is a pity a regulation costume in keeping with the game is not enforced. A lady's modesty does not prevent her from doing gymnastics, for instance, before a large audience, dressed in garments befitting the occasion; and yet she will appear on a tennis court in skirts very often so long that she

is in danger of falling over them and injuring herself, not to speak of losing the stroke, or game or match. I do not propose that ladies should adopt what I believe is called the "rational costume," but surely there is a just medium in all things, and there is no reason why they should not wear short skirts, well above ankles, unless (but this is between the readers of this chapter and myself) the ankles of some of them happen to be unusually large; which special cases might be brought before the committee with a view to special permission to keep to the "trailing garments"!

Apart from the unworkmanlike and clumsy appearance of too long a skirt, it tells against the player, not only by impeding her movements while in the act of running for a stroke, but by causing fatigue unnecessarily; and that is serious in a game which, perhaps more than any other, requires staying power.

Ladies have acquired this most necessary quality to a remarkable extent. It sometimes occurs that a man breaks down under the severe mental and physical strain of a five-set match, and re-

tires before the end. The instances on record of a lady doing this are very rare. Though ladies only play the best of three sets as compared to the men's five, yet, if we take into consideration their inferior physical strength, it seems to imply that women, as a rule, expend less nervous energy than do men at the game; or is it that they have more pluck? This is only a suggestion. That recalls to my mind a very plucky game I witnessed in Germany. It was a few years ago at Homburg, when Miss Jones, the American lady champion, met Miss Robb, our late champion, in the Open Singles. Both ladies played a wonderfully strong game; they were one set all, and Miss Jones was leading 5—3 and 40.15 in the final set. She needed a point to win the set and match; but, whereas Miss Robb was comparatively fresh (I say *comparatively*), poor Miss Jones was at her last gasp, having reached that stage of exhaustion when even the sight becomes affected and the limbs seem to have leaden weights attached to them. I knew that Miss Jones had a weak heart, and her appearance made me feel quite nervous; but she would not

give in, though when the last point was called she could scarcely walk off the court. Miss Robb was ultimately victorious by 9 games to 7; but every game was lengthily contested, and only won after tremendous rallies. Miss Jones lost through inferior staying power. She deserved to win, and with a very little luck would have done so.

I must now say a few words about some of our leading lady players. Mrs. Hillyard has played and won more matches than any other lady; the number of trophies she possesses in the shape of cups is almost incredible. She is a most determined player; however nearly she may seem to be losing a match, she will never lose heart, but will play on with the same pluck and energy to the last stroke. Mrs. Hillyard's personal and distinctive stroke is a powerful and wonderfully accurate forehand drive of a perfect length. She is very active, and covers the court better than most ladies. Mrs. Hillyard and Mrs. Sterry share the proud position of being our two best lady players. Mrs. Sterry's game is more varied than that of Mrs. Hillyard; she possesses more strokes, and is an instance of a player with no one weak point.

She is our best volleyer. Another player who may be bracketed with the two above mentioned, with regard to excellence, is Mrs. Greville. In her case it is interesting to note how strong an influence surroundings and locality may have on a player. Mrs. Greville has a most admirable style, a perfect backhand, is a good volleyer, and has a thorough knowledge of the game. Hers is both an intelligent and a pretty game to watch. She has beaten Mrs. Hillyard several times, and I believe I am accurate in stating that she has beaten Mrs. Sterry thirteen times, and has been beaten fifteen times by our ex-lady champion. She held the covered court Championship at Queen's Club for five years. Yet, with all these successes to her credit, she has invariably failed to do herself justice at Wimbledon. She has told me that the courts and surroundings there exercise an influence over her which is most pernicious to her game. I am aware that this does not prevent people from estimating Mrs. Greville at her just value, only for her own satisfaction it seems a pity she should not have been able to do herself justice at our most important tourna-



ment. Nevertheless, Mrs. Greville at her best is a match for any lady in the United Kingdom.

Miss Robb, who wrested the championship from Mrs. Sterry in 1902, is another very fine player; she is a base-line player and possesses the hardest drive of any lady. Miss Robb is undoubtedly a very strong player, and were her volleying and her backhand as good as her ground and forehand strokes, she would certainly be the best lady player living. But her two last-named strokes are not good, and hence the possible risk she incurs of losing the title of champion which she has so meritoriously won; for, though Mrs. Hillyard lacks both these qualities, Miss Robb has not that never-failing steadiness which characterizes the former celebrated player.

I have been asked to say a few words as to what methods, in my opinion, ladies should adopt in order to play *and win*. I start by saying that the question of service is of importance. Personally (though I practise it myself) I do not believe in the overhead service, and for this reason: unless an overhead service is distinctly severe it is ineffective, and if a lady attains this necessary

severity it is generally at the cost of her vital energy. To keep up a hard overhead service during three sets without its being at this cost, requires more strength than the average woman possesses. Again, as a rule a lady's second service (overhead) is very weak and it is often short; consequently it is generally preferable for ladies to serve underhand and to their opponent's backhand, keeping a good length and imparting a slight "cut" to the ball in order to keep it low (to impart this cut you make the racket travel across the body from right to left). Other advantages of the underhand service are the smaller disparity of pace between the first and second service, also the greater facility of getting in the first without a fault. Miss Dod, who was, perhaps, the best lady player there has ever been, practised the underhand service.

As to the methods that should be adopted while playing the game, I am an advocate of volleying. I do not hesitate to say that, provided two ladies are equally matched in point of excellence, the volleyer will win.

This affirmation is easily proven. Always sup-

posing that the two opponents are of equal merit, the volleyer will theoretically win the point every time the latter makes a short stroke, across the court or otherwise, as it is impossible for the base-line player to run back and to get into position in time; and even were she able to do so, her return would be ineffective, and therefore at the next stroke her opponent (the volleyer) would or should have her at her mercy, because she can intercept this weak return at the net and then place it wherever the base-line player cannot get it.

For the same reason that I do not advise ladies to adopt the overhead service—viz., fatigue—neither am I an advocate of their “running in” on their service. Invaluable as it is to a man’s game, I have never seen it done serviceably in a ladies’ Single, though it is necessary in a Mixed when the man’s partner is a volleyer.

Lastly, I come to the backhand. For some reason few ladies find it worth their while to play this stroke in the right style. The best way to practise it is to grip the handle of the racket tightly and, turning the body sideways, to put the thumb along the handle; this will be found a

great help, as it prevents the head of the racket from turning into a slanting position.

I close this chapter on ladies' tennis by saying that good players are increasing in number every year, and that they are quite as assiduous in giving up as much of their time to practise this most difficult game as are the men.

The best among the foreign players is undoubtedly Countess Schulenberg, the German lady champion. She has a good hard underhand service, an excellent forehand and backhand stroke, and plays altogether a very strong game.

CHAPTER VIII.

SOME HINTS ON THE CONSTRUCTION AND CARE OF  
GRASS COURTS.

BY MR. GEORGE W. HILLYARD.

THE paradise of a lawn tennis player, I take it, would be a perfect English summer day; a well-matched Double; and last, but by no means least, a really good grass court.

The latter adjunct, even in this year of grace 1903, is so great a rarity that I verily believe the majority of people have never seen, much less played on one! It is curious this should be the case, as Great Britain, of all countries in the world, is blessed with splendid natural turf and a suitable climate for keeping it in order. There are dozens of fine bowling-greens, and hundreds of true golf-greens scattered throughout the length and breadth of the kingdom, while a good

*grass* lawn tennis court is almost as rare a sight as a dead donkey! So I am reluctantly forced to conclude that the only explanation for bad courts is the want of a little energy and "elbow grease."

A grass court, if it aspires to come within the term "perfection," must first of all be placed the right way for the sun, and, as most people in England play during the afternoon, the court ought to be laid due north and south. We know of courts on which championships are held—"but that is another story"!

While thinking of the points of the compass it is well for us to ascertain that the contemplated site for the court is large enough. There are few more exasperating inflictions for the long-suffering lawn tennis player than a court good in other respects, but with too little room at the sides and ends, so that to reach any decent "length" or well-placed ball one has to risk either breaking one's neck down a bank or dashing one's brains out against a wall! If the court is 124 feet long by 66 feet wide, as it ought to be, any ordinary insurance company will take these as "fair risks." When choosing your site, try if

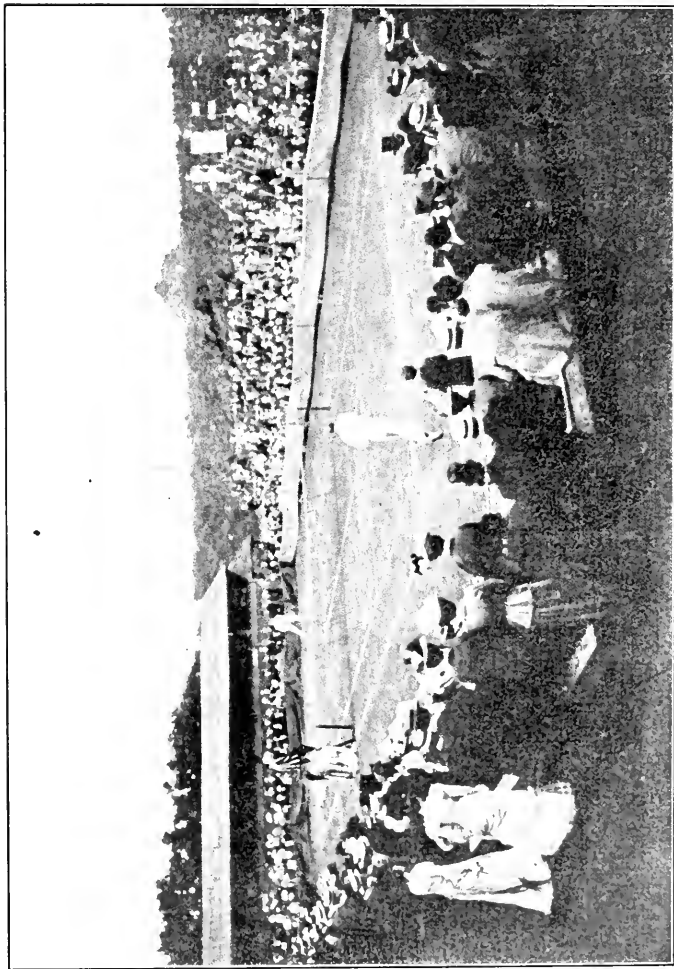

No. 26 THE CENTRE COURT AT WIMBLEDON, WHERE THE ALL-ENGLAND MATCHES ARE PLAYED





possible to take advantage of any natural shelter from the wind, such as a good yew-hedge, or dense mass of shrubs and trees; these will also form a good background. The trees must not be too close to the *west* side of the court, otherwise in the afternoon their shadows will be a nuisance not to be endured.

If you are so situated that no "background" is available, a good plan is to shelter the court all round with a boarded fence, at least 10 feet high, painted a dark green. This will be useful, but, I am afraid, not ornamental. However, if the large-leaved variety of English ivy is planted, the fence will be completely covered in the course of three or four years, and then will be quite the reverse of an eyesore. Of course, if money is no object, a brick wall is still better than boards, as it is a permanency. When a very large amount of digging has to be done before the site of the court can be levelled, the excavated earth may be utilized in throwing up high banks all round, which should be turfed over: this dispenses with any necessity for a fence or wall.

Next comes the all-important point of laying

down the court itself. This we may do in two ways, either by raising the grass from seed or by turfing. If good turf is procurable I should certainly recommend the latter plan, as the court will be ready for play the sooner; but it is no good putting down bad, weedy, clovery turf; it will never give satisfaction, and will be much more bother and expense in the long run. Messrs. Carter, of High Holborn, have dealt so extensively with raising turf from seed, in their excellent little handbook, that here no further reference need be made to that method.

We will assume that good turf is available, and the actual ground has been levelled. Drainage is the next thing to be thought of. The amount will, of course, depend on whether the court is low-lying and wet, or high and naturally well-drained. In the latter event very little will suffice. In the former the ground ought to be thoroughly drained by a system of agricultural pipes laid in a "herring-bone" pattern the whole length of the court, the centre-line, as it were, being the backbone, and the transverse pipes being laid at intervals of about 6 feet, so as to

drain the surface as evenly as possible. Take care that sufficient fall is given the pipes to carry the water away. They will not want to go more than 1 foot into the *solid* ground, as they are only for surface drainage. On top of your solid ground, when the drains have been laid and everything levelled up, you will need at least 1 foot of good loamy soil, which will have to be rolled and raked several times till you get it absolutely level and sufficiently consolidated to allow the delicate operation of turfing to be properly performed. One very important point in the process is to see that the turfs are cut a uniform thickness, otherwise it will be next to impossible to get the surface of the court really true. After the turf is laid it should be well "rammed," and any little inequalities taken out, then rolled with a *light* roller, and again carefully inspected for irregularities. A good plan now is to leave it alone for two or three weeks, to allow the roots of the grass to take hold, and the turfs to settle a bit. It then requires to be well rolled with a *heavy* roller. The best time for turfing is from the end of September until the end of November,

but the earlier the better, as there is less chance of frost interfering with the work, and the turfs have all the longer time to get thoroughly knitted together in readiness for the next season's play. The court ought to be rolled all through the winter (except, of course, during frost) at least once a week with a light roller, and as the spring approaches, say towards the beginning of April, a heavy roller should be substituted.

No hard and fast rule can be laid down for this rolling; it depends entirely upon whether the spring is dry or wet, and must be left to the judgment of the person in charge of the ground. On it will depend in a great measure whether the court is satisfactory or not during the summer.

Never let the grass grow more than 2 inches long at any time of the year. This is a most important point. The only way to obtain a good thick turf is by constant use of the mowing-machine. A great number of people seem to have a vague idea that if the grass is allowed to grow fairly long the court will wear better, but that this notion is a fallacy cannot be too strongly urged. Continual mowing sends strength back

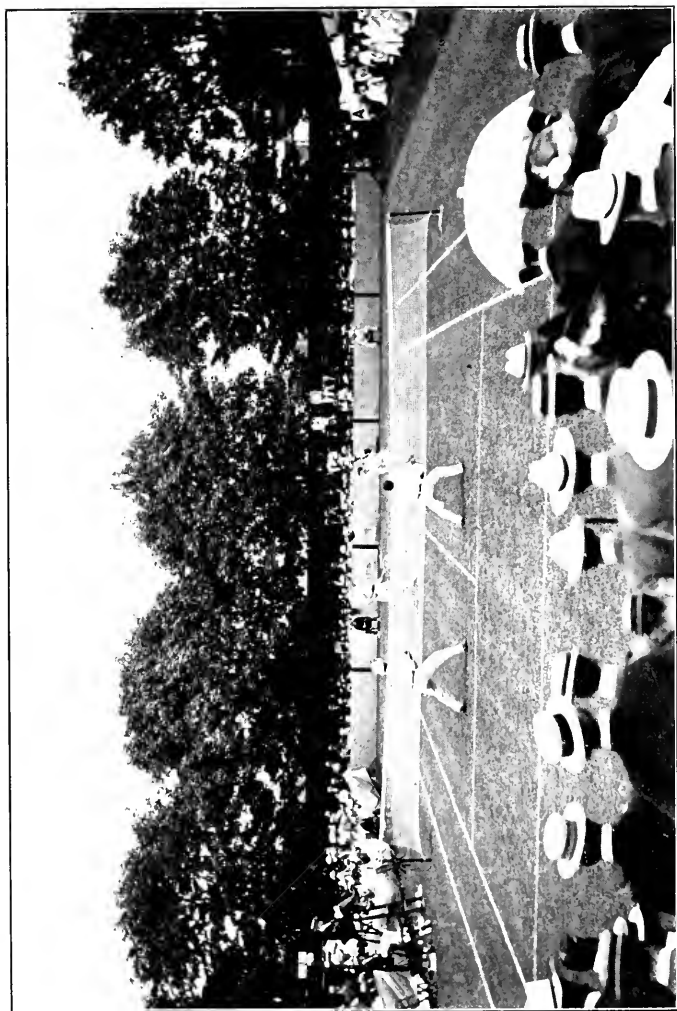

No. 27 THE CHAMPIONSHIP COURT, AT NEWPORT, WHERE THE UNITED STATES MATCHES ARE PLAYED.



into the roots, and forms a close turf, which will not only play far truer, but will wear far better than grass that is allowed to grow 3 or 4 inches long. In fact, during the lawn tennis season the mowing-machine should be set as low as possible without actually scraping the ground.

All weeds must be absolutely rooted out whenever and wherever they appear; if care is taken to make a clean sweep of them at first, it will not be much trouble to keep the court free of them in the future.

During a dry summer the court will need constant watering. This should always be done in the evening when possible, but on dull days any convenient time will do. Personally I find the only way in dry weather to keep a court true on which there is a great deal of play is to water and roll every day. A water-ballast roller weighing about a ton when full, is very handy for this purpose.

At the end of the season you will probably find the base-lines will need returfing, and very likely one or two other spots on the court. The earlier this is done in the autumn the better. This is also

a good time of year to give the court a top dressing; well-rolled short stable or farmyard manure is excellent for this purpose, or, in case this is not easily obtainable, most of our leading seedsmen advertise a special manure.

In conclusion, let me once more point out to all lawn tennis players the absolute necessity of constantly using the roller and mowing-machine if they aspire to play on that most delightful of all courts, perfect turf.



CHAPTER IX.

HOW LAWN TENNIS COMPARES WITH SOME OTHER  
GAMES.

BY EUSTACE MILES.

LAWN TENNIS has sometimes been despised by players of Cricket, as if it were mild pat-ball, suited only for ladies. Perhaps the word "tame" may sum up the condemnation as well as any other word, as implying that Lawn Tennis is easy, gentle, monotonous.

Now, however much our verdict on Lawn Tennis must depend on the way in which it happens to be played, one fact is clear and undeniable, and this is that Lawn Tennis is not easy. I suppose every game looks easy when it is played really well, because every stroke is timed and judged so smoothly and surely: Billiards and

Golf will serve as examples. But when you come to take up a racket and actually try to keep the ball within the side-lines and back-lines, and over the net—just over, or well over by a lob—you are struck by the need of accuracy and of *restraint*. In Racquets, Tennis, Fives, and Squash, there are the side-walls and back-walls to help; in Cricket there are boundaries; but in Lawn Tennis you must keep the ball in. Let anyone who imagines that the play requires no skill, see his opponent, a safe volleyer, up at the net while he himself has to make a backhand stroke from the left-hand corner of the court furthest away from the net. What nicety is required to pass the man at the net! Attempt to pass him down the side or across the court, and you run the risk of hitting the ball out; attempt to lob over his head and you run this same risk or else the risk of giving him a certain smash. So far from calling the stroke easy, you almost call it impossible. And yet it is frequently brought off with success. Pace, direction, length, height, concealment, all are required. The game is not easy.

Is it really gentle? Many spectators tell me

that the modern strokes have lost the pace and severity that the Renshaws used to display. But apart from the fact that there are still some prodigiously hard hitters—Smith in England and Davis in America—one must never lose sight of two points: first, that the modern stroke is faster than it looks and sounds, being often to the bustling hard drive of former years what the express is to the metropolitan engine; secondly, that to-day there is a control of pace, direction (particularly in the cross-court strokes), and length (the latter especially with American players), such as few appreciate who have not personally competed against it. When anyone tells me that the Dohertys hit softly, I know that he judges by the appearance of the stroke, forgetting how much power and pace is imparted by the graceful body-swing and how much pace and spin is imparted by the overturn of the wrist. Lawn Tennis is neither easy nor slow.

Is it monotonous? Some players make it very monotonous, as some players make Cricket very monotonous. But that is not the fault of the game, which allows wonderful variety of net-play

or back-play, of passing or lobbing, and of tactics generally. Success may require patience and endurance, but sameness is not essential to success.

As a social and, in recent years, an international influence Lawn Tennis compares favorably with Golf. All over the world these games bring different people and the two sexes together in the friendliest possible way, forming an incentive to new friendships as well as to travel and exercise. Whereas Cricket, Hockey, and Football require their teams, Lawn Tennis and Golf are content with twos or at the most with fours. And everywhere Lawn Tennis tournament prizes and Golf medals attract players to come and play and talk together. If only Lawn Tennis had used handicaps as regularly and as sensibly as Golf has, there would be less complaint that Lawn Tennis was no longer a game for all, but was becoming more and more a game for a few pot-hunters.

But Lawn Tennis has one very decided advantage over Golf. It demands prompt alertness and rapid recovery of poise. In Golf you can take time before your "stance" and after your

stroke; in Lawn Tennis there is the same sort of choice between this or that stroke as at Golf, but you must decide quickly and act quickly, and again quickly be ready to decide quickly again. There is between the two strokes all the difference between leisurely poise, then the use of force; and rapid poise, then the use of force, then rapid recovery of poise.

But how little of this value, except the social value, is realized by the ordinary player! He or she plays and plays and plays the same old game with the same old faults and follies, utterly ignorant of what is utterly indispensable to style and tactics. I have had the pleasure of reading the manuscript of this book by our two greatest British exponents of style and tactics, and I am delighted to think that there is now no reason why beginners and others should continue in error. The illustrations and explanations allow of no excuse that such and such a point had not been grasped. It seems to me that if the advice offered by the Doherty brothers be carefully read and put into practice, the interest in Lawn Tennis will revive in England as markedly as it has

revived in America, and we as a nation shall profit largely by play which ordinarily demands little time, less strain, no risk, but encourages thought, social intercourse, and healthy outdoor exercise, sufficiently interesting to be worth while for its own sake apart from prizes.

A help towards the spread of Lawn Tennis would be its adoption in Public schools. I cannot believe that it would interfere with Cricket: in American schools like Groton it does not interfere with Baseball. There are too many boys to whom Cricket, as played at present, affords neither pleasure nor exercise. Lawn Tennis, properly taught, would be likely to satisfy both needs.

## CHAPTER X.

## LIST OF CHAMPIONS, RULES AND REGULATIONS, ETC.

## I. COVERED COURT CHAMPIONSHIPS.

*ENGLAND.*

## CHAMPIONS.

1885	H. F. Lawford	1894	H. S. Mahony
1886	E. L. Williams	1895	E. W. Lewis
1887	E. W. Lewis	1896	E. W. Lewis
1888	E. W. Lewis	1897	W. V. Eaves
1889	E. W. Lewis	1898	W. V. Eaves
1890	E. W. Lewis	1899	W. V. Eaves
1891	E. W. Lewis	1900	A. W. Gore
1892	E. G. Meers	1901	H. L. Doherty
1893	H. S. Mahony	1902	H. L. Doherty
	1903		H. L. Doherty

## LADY CHAMPIONS.

1890	Miss Jacks	1892	Miss M. Shackle
1891	Miss M. Shackle	1893	Miss M. Shackle

1894	Miss Austin	1899	Miss Austin
1895	Miss C. Cooper	1900	Miss T. Lowther
1896	Miss Austin	1901	Mrs. Hillyard
1897	Miss Austin	1902	Miss T. Lowther
1898	Miss Austin	1903	Miss T. Lowther

## DOUBLES CHAMPIONS.

1890	G. W. Hillyard and H. S. Scrivener
1891	G. W. Hillyard and H. S. Scrivener
1892	E. G. Meers and H. S. Mahony
1893	E. G. Meers and H. S. Mahony
1894	E. G. Meers and H. S. Mahony
1895	W. V. Eaves and C. H. Martin
1896	W. V. Eaves and C. H. Martin
1897	H. A. Nisbet and G. Greville
1898	R. F. Doherty and H. L. Doherty
1899	R. F. Doherty and H. L. Doherty
1900	R. F. Doherty and H. L. Doherty
1901	R. F. Doherty and H. L. Doherty
1902	R. F. Doherty and H. L. Doherty
1903	R. F. Doherty and H. L. Doherty

## MIXED DOUBLES CHAMPIONS.

1898	R. F. Doherty and Miss C. Cooper
1899	R. F. Doherty and Miss C. Cooper
1900	R. F. Doherty and Miss C. Cooper



- 1901 G. W. Hillyard and Mrs. Hillyard  
 1902 H. L. Doherty and Miss T. Lowther  
 1903 H. L. Doherty and Miss T. Lowther

WALES.

CHAMPIONS.

- |      |                |      |               |
|------|----------------|------|---------------|
| 1893 | J. H. Crispe   | 1898 | H. S. Mahony  |
| 1894 | W. S. N. Heard | 1899 | G. A. Caridia |
| 1895 | R. F. Doherty  | 1900 | G. A. Caridia |
| 1896 | R. F. Doherty  | 1901 | G. A. Caridia |
| 1897 | R. F. Doherty  | 1902 | G. A. Caridia |

LADY CHAMPIONS.

- |      |                |                |                 |
|------|----------------|----------------|-----------------|
| 1896 | Mrs. Pickering | 1899           | Miss M. E. Robb |
| 1897 | Miss Dyas      | 1900           | Miss M. E. Robb |
| 1898 | Miss Dyas      | 1901           | Miss M. E. Robb |
|      | 1902           | Miss L. Clarke |                 |

FRANCE.

CHAMPIONS.

- |      |                |            |                  |
|------|----------------|------------|------------------|
| 1895 | A. Vacherot    | 1899       | M. J. G. Ritchie |
| 1896 | M. F. Goodbody | 1900       | G. A. Caridia    |
| 1897 | M. F. Goodbody | 1901       | G. M. Simond     |
| 1898 | G. M. Simond   | 1902       | M. J. G. Ritchie |
|      | 1903           | M. Decugis |                  |

## LAWN TENNIS.

## LADY CHAMPIONS.

1897 Mlle. Masson | 1898-1903 [No competition]

## DOUBLES CHAMPIONS.

1901 G. M. Simond and G. A. Caridia

1902 G. M. Simond and G. A. Caridia

*UNITED STATES.*

## CHAMPIONS.

1898 L. E. Ware

1899 L. E. Ware

1900 L. E. Ware

1901 H. Ward

1902 J. P. Paret

1903 W. C. Grant

## DOUBLES CHAMPIONS.

1902 W. C. Grant and Le Roy

1903 W. C. Grant and Le Roy

*STOCKHOLM.*

## OPEN

1900 J. M. Flavelle . . .

1901 F. W. Payn . . .

## SWEDES ONLY

1900 G. Settervall

1901 G. Settervall

OXFORD *v.* CAMBRIDGE.

1881	Oxford won by 14 matches to 4
1882	“ 13 “ 5
1883	“ 12 “ 6
1884	Cambridge “ 15 “ 3
1885	“ 12 “ 6
1886	“ 16 “ 2
1887	A draw. Nine matches all
1888	Abandoned after one hour's play
* 1889	A draw { Cambridge 12 matches Oxford 5 “
1890	Cambridge won by 11 matches to 7
* 1891	A draw { Cambridge 11 matches Oxford 7 “
1892	Cambridge won by 17 matches to 1
1893	“ 12 “ 6
1894	“ 12 “ 6
1895	“ 17 “ 1
1896	“ 18 “ 0
1897	“ 13 “ 5
1898	“ 10 “ 8

---

\*These matches were apparently counted as drawn by arrangement. By the ordinary method of scoring in matches, Cambridge won on each occasion.

1899

Played at Queen's Club on June 31 and July 1.

*Singles.*

Oxford won by 6 matches to 3.

TEAMS.—*Oxford*: P. G. Pearson, H. R. Fussell, and A. N. Dudley. *Cambridge*: A. M. Mackay, N. J. Waller, and M. F. Day.

*Doubles.*

Cambridge won by 5 matches to 4.

TEAMS.—*Cambridge*: A. M. Mackay and M. F. Day; N. J. Waller and D. G. Fry; G. C. Glenny and A. C. Hudson. *Oxford*: P. G. Pearson and H. R. Fussell; B. Wood-Hill and W. Horton; A. N. Dudley and G. L. W. Hill.

RESULT.—Oxford won by 10 matches to 8.

1900.

Played at Queen's Club on July 3 and 4.

*Singles.*

Oxford won by 5 matches to 4.

TEAMS.—*Oxford*: P. G. Pearson, H. R. Fussell, and B. Wood-Hill. *Cambridge*: G. C. Glenny, D. G. Fry, and F. Salzmänn.

*Doubles.*

Cambridge won by 5 matches to 4.

TEAMS.—*Cambridge*: G. C. Glenney and D. G. Fry; F. Salzmänn and T. A. Cock; G. E. Sunderland Taylor and S. M. Porter. *Oxford*: P. G. Pearson and B. Wood-Hill; H. R. Fussell and C. F. Ryder; H. Plaskitt and T. D. Rudkin.

RESULT.—A draw; 9 matches all.

1901.

Played at Queen's Club on July 3 and 4.

*Singles.*

Oxford won by 5 matches to 4.

TEAMS.—*Oxford*: P. G. Pearson, W. C. Crawley, and H. Plaskitt. *Cambridge*: D. G. Fry, F. Salzmänn, and F. W. Argyle.

*Doubles.*

Oxford won by 6 matches to 3.

TEAMS.—*Oxford*: P. G. Pearson and H. Plaskitt; W. C. Crawley and P. T. Oyler; B. Wood-Hill and C. F. Ryder. *Cambridge*: D. C. Fry and F. Salzmänn; F. W. Argyle and J. C. Fisher; J. R. L. Nicholls and E. Wells.

RESULT.—Oxford won by 11 matches to 7.

SUMMARY.—Of 21 competitions Cambridge has won 11 and Oxford 5. Four have been drawn, and one (1888) was abandoned after an hour's play. In Singles Cambridge has won 108 matches as against 71 to Oxford, and in Doubles Cambridge has won 117 matches to Oxford's 62. Total matches: Cambridge, 225; Oxford, 133.

---

## II. LIST OF CHAMPIONS.

### ENGLAND.

#### CHAMPIONS.

1877	S. W. Gore	1890	W. J. Hamilton
1878	P. F. Hadow	1891	W. Baddeley
1879	J. T. Hartley	1892	W. Baddeley
1880	J. T. Hartley	1893	J. Pim
1881	W. Renshaw	1894	J. Pim
1882	W. Renshaw	1895	W. Baddeley
1883	W. Renshaw	1896	H. S. Mahony
1884	W. Renshaw	1897	R. F. Doherty
1885	W. Renshaw	1898	R. F. Doherty
1886	W. Renshaw	1899	R. F. Doherty
1887	H. F. Lawford	1900	R. F. Doherty
1888	E. Renshaw	1901	A. W. Gore
1889	W. Renshaw	1902	H. L. Doherty
	1903		H. L. Doherty

## ALL COMERS' SINGLES.

	WINNER		SECOND
1877	S. W. Gore . . .	.	W. Marshall
1878	P. F. Hadow . . .	.	W. Erskine
1879	J. T. Hartley . . .	.	W. "St. Leger"
1880	H. F. Lawford . . .	.	O. E. Woodhouse
1881	W. Renshaw . . .	.	R. T. Richardson
1882	E. Renshaw . . .	.	R. T. Richardson
1883	E. Renshaw . . .	.	D. Stewart
1884	H. F. Lawford . . .	.	C. W. Grinstead
1885	H. F. Lawford . . .	.	E. Renshaw
1886	H. F. Lawford . . .	.	E. W. Lewis
1887	H. F. Lawford . . .	.	E. Renshaw
1888	E. Renshaw . . .	.	E. W. Lewis
1889	W. Renshaw . . .	.	H. S. Barlow
1890	W. J. Hamilton . . .	.	H. S. Barlow
1891	W. Baddeley . . .	.	J. Pim
1892	J. Pim . . .	.	E. W. Lewis
1893	J. Pim . . .	.	H. S. Mahony
1894	W. Baddeley . . .	.	E. W. Lewis
1895	W. Baddeley . . .	.	W. V. Eaves
1896	H. S. Mahony . . .	.	W. V. Eaves
1897	R. F. Doherty . . .	.	W. V. Eaves
1898	H. L. Doherty . . .	.	H. S. Mahony
1899	A. W. Gore . . .	.	S. H. Smith
1900	S. H. Smith . . .	.	A. W. Gore
1901	A. W. Gore . . .	.	C. P. Dickson

ALL COMERS' SINGLES—*Continued.*

1902	H. L. Doherty . . .	M. J. Ritchie
1903	F. L. Riseley . . .	M. J. Ritchie

## LADY CHAMPIONS.

1884	Miss Maud Watson
1885	Miss Maud Watson
1886	Miss Bingley
1887	Miss L. Dod
1888	Miss L. Dod
1889	Mrs. Hillyard
1890	Miss Rice
1891	Miss Dod
1892	Miss Dod
1893	Miss Dod
1894	Mrs. Hillyard
1895	Miss C. Cooper
1896	Miss C. Cooper
1897	Mrs. Hillyard
1898	Miss C. Cooper
1899	Mrs. Hillyard
1900	Mrs. Hillyard
1901	Mrs. Sterry
1902	Miss Robb
1903	Miss Douglass



## DOUBLES CHAMPIONS.

- 1879 L. R. Erskine and H. F. Lawford  
1880 W. Renshaw and E. Renshaw  
1881 W. Renshaw and E. Renshaw  
1882 J. T. Hartley and R. T. Richardson  
1883 C. W. Grinstead and C. D. Weldon  
1884 W. Renshaw and E. Renshaw  
1885 W. Renshaw and E. Renshaw  
1886 W. Renshaw and E. Renshaw  
1887 P. B. Lyon and H. W. W. Wilberforce  
1888 W. Renshaw and E. Renshaw  
1889 W. Renshaw and E. Renshaw  
1890 J. Pim and F. O. Stoker  
1891 W. Baddeley and H. Baddeley  
1893 J. Pim and F. O. Stoker  
1893 J. Pim and F. O. Stoker  
1894 W. Baddeley and H. Baddeley  
1895 W. Baddeley and H. Baddeley  
1896 W. Baddeley and H. Baddeley  
1897 R. F. Doherty and H. L. Doherty  
1898 R. F. Doherty and H. L. Doherty  
1899 R. F. Doherty and H. L. Doherty  
1900 R. F. Doherty and H. L. Doherty  
1901 R. F. Doherty and H. L. Doherty  
1902 S. H. Smith and F. L. Riseley  
1903 R. F. Doherty and H. L. Doherty

## MIXED DOUBLES CHAMPIONS.

- 1888 E. Renshaw and Mrs. Hillyard  
1889 J. C. Kay and Miss L. Dod  
1890 J. Baldwin and Miss K. Hill  
1891 J. C. Kay and Miss Jackson  
1892 A. Dod and Miss Dod  
1893 W. Baddeley and Mrs. Hillyard  
1894 H. S. Mahony and Miss C. Cooper  
1895 H. S. Mahony and Miss C. Cooper  
1896 H. S. Mahony and Miss C. Cooper  
1897 H. S. Mahony and Miss C. Cooper  
1898 H. S. Mahony and Miss C. Cooper  
1899 C. H. L. Cazalet and Miss M. E. Robb  
1900 H. L. Doherty and Miss C. Cooper  
1901 S. H. Smith and Miss Martin  
1902 S. H. Smith and Miss Martin

## LADIES' DOUBLES CHAMPIONS.

- 1885 Mrs. Watts and Miss Bracewell  
1886 Miss L. Dod and Miss M. Langrishe  
1887 Miss L. Dod and Miss M. Langrishe  
1888 Miss L. Dod and Miss M. Langrishe  
1889 Miss M. Steedman and Miss B. Steedman  
1890 Miss M. Steedman and Miss B. Steedman  
1891 Miss L. Marriott and Miss M. Marriott  
1892 Miss Jackson and Miss Crofton

- 1893 Mrs. Hillyard and Miss Steedman  
 1894 Mrs. Hillyard and Miss Steedman  
 1895 Mrs. Hillyard and Miss Steedman  
 1896 Mrs. Hillyard and Miss Steedman  
 1897 Mrs. Hillyard and Mrs. Pickering  
 1898 Miss Steedman and Miss R. Dyas  
 1899 Mrs. Durlacher and Miss Steedman  
 1900 Mrs. Pickering and Miss Robb  
 1901 Mrs. Pickering and Miss Robb  
 1902 Mrs. Pickering and Miss Robb

*IRELAND.*

## GENTLEMEN'S SINGLES.

- |      |                |      |               |
|------|----------------|------|---------------|
| 1879 | V. "St. Leger" | 1891 | E. W. Lewis   |
| 1880 | W. Renshaw     | 1892 | E. Renshaw    |
| 1881 | W. Renshaw     | 1893 | J. Pim        |
| 1882 | W. Renshaw     | 1894 | J. Pim        |
| 1883 | E. Renshaw     | 1895 | J. Pim        |
| 1884 | H. F. Lawford  | 1896 | W. Baddeley   |
| 1885 | H. F. Lawford  | 1897 | W. V. Eaves   |
| 1886 | H. F. Lawford  | 1898 | H. S. Mahony  |
| 1887 | E. Renshaw     | 1899 | R. F. Doherty |
| 1888 | E. Renshaw     | 1900 | R. F. Doherty |
| 1889 | W. J. Hamilton | 1901 | R. F. Doherty |
| 1890 | E. W. Lewis    | 1902 | H. L. Doherty |

## LADIES' SINGLES.

1879	Miss M. Langrishe	1891	Miss Martin
1880	Miss Meldon	1892	Miss Martin
1881	[No competition]	1893	Miss Stanuell
1882	Miss Abercrombie	1894	Mrs. Hillyard
1883	Miss M. Langrishe	1895	Miss C. Cooper
1884	Miss M. Watson	1896	Miss Martin
1885	Miss M. Watson	1897	Mrs. Hillyard
1886	Miss M. Langrishe	1898	Miss C. Cooper
1887	Miss L. Dod	1899	Miss Martin
1888	Mrs. Hillyard	1900	Miss Martin
1889	Miss Martin	1901	Miss Robb
1890	Miss Martin	1902	Miss Martin

## GENTLEMEN'S DOUBLES.

1879	J. Elliott and H. Kellie
1880	H. F. Lawford and A. J. Mulholland
1881	W. Renshaw and E. Renshaw
1882	E. de S. Browne and P. Aungier
1883	W. Renshaw and E. Renshaw
1884	W. Renshaw and E. Renshaw
1885	W. Renshaw and E. Renshaw
1886	W. J. Hamilton and H. K. McKay
1887	W. J. Hamilton and T. S. Champion
1888	W. J. Hamilton and T. S. Champion
1889	E. W. Lewis and G. W. Hillyard

- 1890 J. Pim and F. O. Stoker
- 1891 J. Pim and F. O. Stoker
- 1892 E. W. Lewis and E. G. Meers
- 1893 J. Pim and F. O. Stoker
- 1894 J. Pim and F. O. Stoker
- 1895 J. Pim and F. O. Stoker
- 1896 W. Baddeley and H. Baddeley
- 1897 W. Baddeley and H. Baddeley
- 1898 R. F. Doherty and H. L. Doherty
- 1899 R. F. Doherty and H. L. Doherty
- 1900 R. F. Doherty and H. L. Doherty
- 1901 R. F. Doherty and H. L. Doherty
- 1902 R. F. Doherty and H. L. Doherty

## MIXED DOUBLES.

- 1879 J. Elliott and Miss Costello
- 1880 S. D. Maul and Miss Costello
- 1881 W. Renshaw and Miss Abercrombie
- 1882 E. de S. Browne and Miss Perry
- 1883 E. de S. Browne and Miss M. Langrishe
- 1884 W. Renshaw and Miss M. Watson
- 1885 W. Renshaw and Miss M. Watson
- 1886 E. Chatterton and Miss M. Langrishe
- 1887 E. Renshaw and Miss L. Dod
- 1888 E. W. Lewis and Miss Bracewell
- 1889 W. J. Hamilton and Miss Rice
- 1890 D. G. Chaytor and Miss Martin
- 1891 D. G. Chaytor and Miss Martin

MIXED DOUBLES—*Continued.*

- 1892 D. G. Chaytor and Miss Martin  
 1893 M. F. Goodbody and Miss E. C. Pinckney  
 1894 G. W. Hillyard and Mrs. Hillyard  
 1895 H. S. Mahony and Miss C. Cooper  
 1896 H. S. Mahony and Miss C. Cooper  
 1897 G. Greville and Mrs. Hillyard  
 1898 H. A. Nisbet and Miss R. Dyas  
 1899 R. F. Doherty and Miss C. Cooper  
 1900 R. F. Doherty and Miss C. Cooper  
 1901 H. L. Doherty and Mrs. Durlacher  
 1902 H. L. Doherty and Mrs. Durlacher

## LADIES' DOUBLES.

- 1884 Miss Langrishe and Miss M. Langrishe  
 1885 Miss Watson and Miss M. Watson  
 1886 Miss Butler and Miss L. Martin  
 1887 Miss Martin and Miss Stanuell  
 1888 Miss M. Steedman and Miss B. Steedman  
 1889 Miss Martin and Miss Stanuell  
 1890 Miss Martin and Miss Stanuell  
 1891 Miss Martin and Miss Stanuell  
 1892 Miss Dod and Miss Steedman  
 1893 Miss Corder and Miss Shaw  
 1894 Mrs. Hillyard and Miss Snook  
 1895 Miss Cooper and Miss C. Cooper  
 1896 Mrs. Pickering and Miss Dyas

- 1897 Mrs. Hillyard and Miss C. Cooper  
1898 Miss L. Martin and Miss R. Dyas  
1899 Mrs. Durlacher and Miss Martin  
1900 Miss C. Cooper and Miss E. Cooper  
1901 Mrs. Durlacher and Miss Martin  
1902 Mrs. Durlacher and Miss Hazlett

*SCOTLAND.*

## GENTLEMEN'S SINGLES.

- 1878 J. Patten  
1879 L. M. Balfour  
1880 J. Patten  
1881 J. G. Horn  
1882 J. G. Horn  
1883 J. G. Horn  
1884 R. Gamble  
1885 P. B. Lyon  
1886 P. B. Lyon  
1887 H. Grove  
1888 P. B. Lyon  
1889 E. de S. H. Browne  
1890 E. de S. H. Browne  
1891 E. de S. H. Browne  
1892 A. W. Gore  
1893 A. W. Gore  
1894 R. M. Watson

## LAWN TENNIS.

GENTLEMEN'S SINGLES—*Continued.*

1895	R. F. Doherty
1896	R. F. Doherty
1897	R. F. Doherty
1898	H. L. Doherty
1899	E. D. Black
1900	C. R. D. Pritchett
1901	W. V. Eaves
1902	F. L. Riseley

## LADIES' SINGLES.

1886	Miss Boulton	1894	Miss L. Paterson
1887	Miss Butler	1895	Miss L. Paterson
1888	Miss Butler	1896	Miss L. Paterson
1889	Miss Butler	1897	Miss Hunter
1890	Miss Jackson	1898	Mrs. O'Neill
1891	Miss Jackson	1899	Miss C. Cooper
1892	Miss Jackson	1900	Miss Hunter
1893	Miss Corder	1901	Miss Robb

## GENTLEMEN'S DOUBLES.

1878	A. G. Murray and C. C. Maconochie
1879	A. G. Murray and C. C. Maconochie
1880	A. G. Murray and C. C. Maconochie
1881	J. G. Horn and W. Horn
1882	C. B. Russell and M. G. Lascelles



- 1883 F. A. Fairlie and A. L. Davidson  
1884 P. B. Lyon and H. B. Lyon  
1885 E. W. Lewis and R. M. Watson  
1886 P. B. Lyon and H. B. Lyon  
1887 P. B. Lyon and H. B. Lyon  
1888 P. B. Lyon and H. B. Lyon  
1889 A. Thomson and J. H. Conyers  
1890 E. de S. H. Browne and J. G. Horn  
1891 R. M. Watson and E. B. Fuller  
1892 H. G. Nadin and H. E. Caldecott  
1893 A. W. Gore and R. M. Watson  
1894 R. M. Watson and H. G. Nadin  
1895 C. H. Martin and S. L. Bathurst  
1896 E. R. Allen and C. G. Allen  
1897 R. F. Doherty and H. L. Doherty  
1898 R. F. Doherty and H. L. Doherty  
1899 E. D. Black and C. Hobart  
1900 C. R. D. Pritchett and A. W. McGregor  
1901 W. V. Eaves and E. D. Black  
1902 C. R. D. Pritchett and A. W. McGregor

*WALES.*

## GENTLEMEN'S SINGLES.

- 1886 E. de S. H. Browne  
1887 E. de S. H. Browne  
1888 W. J. Hamilton

GENTLEMEN'S SINGLES—*Continued.*

1889	W. J. Hamilton
1890	W. J. Hamilton
1891	H. S. Barlow
1892	H. S. Barlow
1893	G. Ball-Greene
1894	G. C. Ball-Greene
1895	W. V. Eaves
1896	[No competition]
1897	S. H. Smith
1898	S. H. Smith
1899	S. H. Smith
1900	S. H. Smith
1901	S. H. Smith
1902	S. H. Smith

## LADIES' SINGLES.

1887	Miss M. Watson
1888	Miss Hillyard
1889	Mrs. Pope
1890	[No competition]
1891	Miss Pope
1892	Miss M. Sweet-Escott
1893	Miss Cochrane
1894	Miss Jackson
1895	Miss Corder

- 1896 [No competition]  
 1897 Miss H. Ridding  
 1898 Miss A. E. Parr  
 1899 Miss M. E. Robb  
 1900 Miss C. Hill  
 1901 Miss W. A. Longhurst

*UNITED STATES.*

## GENTLEMEN'S SINGLES.

1881	R. D. Sears	1892	O. S. Campbell
1882	R. D. Sears	1893	R. D. Wrenn
1883	R. D. Sears	1894	R. D. Wrenn
1884	R. D. Sears	1895	F. H. Hovey
1885	R. D. Sears	1896	R. D. Wrenn
1886	R. D. Sears	1897	R. D. Wrenn
1887	R. D. Sears	1898	M. D. Whitman
1888	H. W. Slocum	1899	M. D. Whitman
1889	H. W. Slocum	1900	M. D. Whitman
1890	O. S. Campbell	1901	W. A. Larned
1891	O. S. Campbell	1902	W. A. Larned

## GENTLEMEN'S DOUBLES.

- 1881 C. M. Clark and F. W. Taylor  
 1882 R. D. Sears and James Dwight  
 1883 R. D. Sears and James Dwight

GENTLEMEN'S DOUBLES—*Continued.*

- 1884 R. D. Sears and James Dwight  
 1885 R. D. Sears and J. S. Clark  
 1886 R. D. Sears and James Dwight  
 1887 R. D. Sears and James Dwight  
 1888 O. S. Campbell and V. G. Hall  
 1889 H. W. Slocum and H. A. Taylor  
 1890 V. G. Hall and C. Hobart  
 1891 O. S. Campbell and R. P. Huntingdon, Jr.  
 1892 O. S. Campbell and R. P. Huntingdon, Jr.  
 1893 C. Hobart and F. H. Hovey  
 1894 C. Hobart and F. H. Hovey  
 1895 M. G. Chase and R. D. Wrenn  
 1896 C. B. Neel and S. R. Neel  
 1897 L. E. Ware and G. P. Sheldon  
 1898 L. E. Ware and G. P. Sheldon  
 1899 H. Ward and D. F. Davis  
 1900 H. Ward and D. F. Davis  
 1901 H. Ward and D. F. Davis  
 1902 R. F. Doherty and H. L. Doherty

## LADIES' SINGLES.

- 1887 Miss N. F. Hansell  
 1888 Miss B. Townsend  
 1889 Miss B. Townsend  
 1890 Miss E. C. Roosevelt

1891	Miss M. E. Cahill
1892	Miss M. E. Cahill
1893	Miss A. M. Terry
1894	Miss H. Helwig
1895	Miss J. Atkinson
1896	Miss B. Moore
1897	Miss J. Atkinson
1898	Miss J. Atkinson
1899	Miss Marion Jones
1900	Miss McAteer
1901	Miss B. Moore
1902	Miss M. Jones

*CANADA.*

## CHAMPION.

1897	L. E. Ware		1899	M. D. Whitman
1898	L. E. Ware		1900	M. D. Whitman

## LADY CHAMPION.

1898	Miss J. Atkinson
1899	Miss V. Summerhayes
1900	Miss V. Summerhayes

*VICTORIA.*

CHAMPION.		LADY CHAMPION.	
1897	A. Kearney		
1898	A. Kearney . .	1898	Miss P. Howitt
1898	A. Dunlop . .	1899	Miss P. Howitt
	A. Dunlop . .		
		1902	Miss Gyton

*NEW SOUTH WALES.*

CHAMPION.		LADY CHAMPION.	
1897	C. Curtis	1897	Miss P. Howitt
1898	H. Crossmann	1898	Miss P. Howitt
1899	A. Kearney	1899	Miss P. Howitt
1900	— Rice	1900	Miss Payten
1901	A. Kearney	1901	Miss Payten
1902	W. V. Eaves	1902	Miss Payten

*NATAL.*

CHAMPION.		LADY CHAMPION.	
1896	H. Miller	1896	Miss N. Hickman
1898	C. E. Finlason	1898	Miss N. Hickman
1899	G. C. Collins	1899	Miss N. Hickman
1900	G. C. Collins	1900	Miss N. Hickman
1901	G. C. Collins		
1902	G. C. Collins	1902	Miss N. Hickman

*SOUTH AFRICA.*

CHAMPION.

LADY CHAMPION.

1897	L. Giddy . .	1897	Miss N. Hickman
1899	L. G. Heard .	1899	Miss N. Hickman
1902	C. Heath . . .	1902	Miss N. Hickman

*EUROPE.*

CHAMPION.

1899	H. S. Mahony	1901	M. Decugis
1900	M. J. G. Ritchie	1902	H. L. Doherty

*GERMANY.*

CHAMPION.

LADY CHAMPION.

1897	G. W. Hillyard	1897	Mrs. Hillyard
1898	H. S. Mahony	1898	Miss Lane
1899	C. Hobart	1899	Miss C. Cooper
1900	C. W. Hillyard	1900	Mrs. Hillyard
1901	Max Decugis	1901	Miss T. Lowther
1902	Max Decugis	1902	Miss M. Ross

CHAMPION OF THE GERMANS.

1896	Count V. Voss	1899	Count V. Voss
1897	G. Wantzelius	1900	V. von Muller
1898	Count V. Voss	1901	H. von Schneider

## LAWN TENNIS.

*AUSTRIA.*

CHAMPION.		LADY CHAMPION.	
1896	H. Guy		
1897	H. Dering		
1898	J. André		
1899	H. Dering . .	1899	Frl. B. Kaiser
1900	M. J. G. Ritchie	1900	Frl. B. Kaiser
1901	M. J. G. Ritchie	1901	Miss Lane

*BELGIUM.*

CHAMPION.		LADY CHAMPION.	
1900	H. Roper Barrett	1900	Mme. Trasenter
1901	H. Roper Barrett	1901	Mme. Trasenter

CHAMPION OF THE BELGIANS.		LADY CHAMPION.	
1900	P. de Borman	1901	Mme. Comblen
1901	W. Lemaire de Warzée		
1902	P. de Borman		

*PRUSSIA.*

CHAMPION.			
1896	Dr. W. Bonne	1899	A. von Gordon
1897	Lieut. Bencard	1900	A. W. Schmitz
1898	J. André	1901	A. W. Schmitz



*THE NETHERLANDS.*

## CHAMPION.

1899	K. W. A. Beukema		1900	J. M. Flavelle
			1901	J. M. Flavelle

*SWITZERLAND.*

## CHAMPION.

## LADY CHAMPION.

1898	R. B. Hough			
1899	G. M. Simond .	1899	Miss Brooksmith	
1900	E. K. Harvey .	1900	Miss Brooksmith	
1901	M. Harran . .	1901	Miss Brooksmith	

## CHAMPION OF THE SWISS.

1898	A. Bovet		1900	G. Patry
1899	Dr. de Trey		1901	G. Patry

## HOW TO MARK OUT A COURT

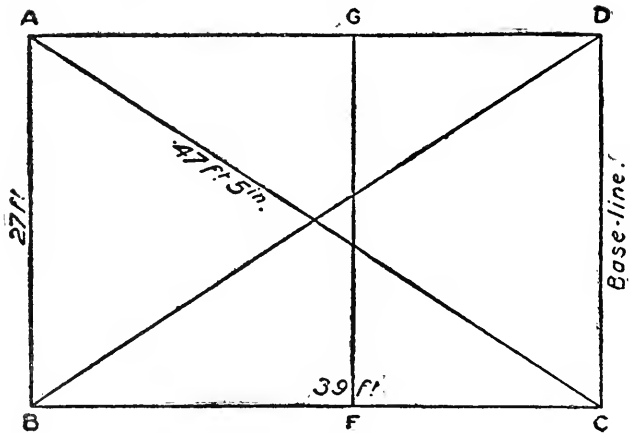

As a double court practically includes every line to be found in a single court, it is best to first take the measurement for the latter. Having determined the position of your net, plant in the ground in the line chosen two pegs, 27 feet apart (at the points A and B in the diagram). Then take two measures and attach their respective ends to the pegs A and B. On

the first, which will measure the diagonal of the court, take a length of 47 feet 5 inches, on the other 39 feet; pull both taut in such directions that at these distances they meet in a point C. This will give one corner of the court. At the point F, 21 feet from B, put in a peg to mark the end of the service-line. The other corner D, and the other end of the service-line G, may be found by interchanging the measures and repeating the process. The same measurements on the other side of the net will complete the exterior boundaries of the court. By prolonging the base-lines 4 feet 6 inches in each direction and joining the four new points thus obtained, we can make the side-lines of a double court. It only remains to make the central-line. This is done by joining the middle points of the service-lines. If a double court alone is required, the interior side-lines need not be prolonged to meet the base-lines. Remember that in all cases the net posts must stand at a distance of 3 feet from the side-lines, and therefore that if a single game is to be played in a double court, the net (unless the posts are shifted

and a single-court net is used) should be stayed up to the right height by means of subsidiary posts placed at a distance of 3 feet from the single court side-lines. Special posts for this purpose, usually known as "single posts," which can be quickly set up and removed, are obtainable from all makers of lawn tennis implements.

REGULATIONS FOR THE INTERNATIONAL LAWN TENNIS CHAMPIONSHIP.

1. The competition shall be called "The International Lawn Tennis Championship," and shall be open to any nation which has a recognized lawn tennis association, and for the purposes of these regulations, Australia with New Zealand, Austria, Belgium, the British Isles, British South Africa, Canada, France, Germany, Holland, India, Sweden and Norway, Switzerland, and the United States of America shall be regarded as separate nations. The competition shall take place in accordance with the following regulations and, except in so far as may be agreed upon by the unanimous consent of the competing nations for their own tie, with the laws and regulations of the game for the time

being sanctioned by the nation in whose country the challenge tie shall from time to time be played.

2. The management of the competition shall be entrusted to a committee appointed annually by the lawn tennis association of the champion nation. When gate-money shall be taken, one-half of the profit shall belong to the visiting nation; or, in the case of a tie being played on neutral ground, one-third each to the visiting nation.

3. For the year 1900 the challenge tie shall be played in the United States of America, but in subsequent years in the country of the champion nation at a date and upon a ground to be agreed upon by common consent. In the event of an agreement not being arrived at, the fixing of the date and the ground shall be submitted to arbitration. Any nation wishing to compete shall give notice to the secretary of the lawn tennis association of the champion nation, so that it shall reach him not later than the first Monday in March of the year in which the competition is to take place. Should more than one nation chal-

## CHAMPIONSHIP REGULATIONS. 189

lenge, they shall compete among themselves for the right to play in the challenge tie, at a date and upon a ground to be agreed upon by common consent.

In the event of an agreement not being arrived at, the preliminary ties shall be played in the country of the champion nation at a date and upon a ground to be fixed upon by the committee of management. Should no challenge be received by the first Monday of March in the year in which the competition is to take place, or if such challenge as may be received by that time be withdrawn, the first challenge received thereafter shall be a good challenge, provided it is received before the first day of May of said year.

4. A player shall be qualified to represent a nation if he shall have been born in that nation, or shall have resided therein for at least two years immediately preceding a tie, providing always that he be a *bona-fide* amateur; but no one shall be entitled to play for more than one nation in this competition during the same year. During the time that a player may be qualifying to play for a nation under the residential quali-

fication, he may play for the nation for which he shall have last previously been qualified.

5. A referee shall be appointed by common consent of the competing sides. He shall have power to appoint umpires, and shall decide any point of law which an umpire may profess himself unable to decide, or which may be referred to him on appeal from the decision of an umpire by the players. He shall decide, if he be called upon to decide by the captain of either side, whether or not a match or matches shall be stopped owing to the state of the courts, the state of the weather, darkness, or other unavoidable hindrance.

6. The players shall be chosen in the Single and Double contests by their respective captains from not more than four players nominated by the lawn tennis associations of the competing nations. Notice of such nomination shall be sent to the secretary of the lawn tennis association of the opposing nation not later than twenty-one days previous to the commencement of a tie, and in such a way that it shall reach him not later than seven days before the commencement



of play. Each tie shall be decided by the combined results of Singles and Doubles, and the side which shall win the majority of matches shall be the winner of a tie. Should four players be nominated, it shall at the same time be stated which are to take part in the Singles and which in the Doubles.

7. The time of cessation of play shall be fixed before the commencement of each day's play by the captains of the opposing sides, or by the referee if they shall disagree. It shall be the duty of the referee to stop play when this time arrives; provided, nevertheless, that he may extend the time with the consent of the captains of the opposing sides. A player shall not be called upon to play more than one match a day, except with the unanimous consent of the captains of the opposing sides and the committee of management.

8. In the Singles each team shall consist of two players who shall play each against each of the opposing team the best of five advantage sets. The order of play shall be decided by lot.

9. In the Doubles each team shall consist of

two players, who shall play against the opposing team the best of five advantage sets.

10. In Singles and Doubles notice of the teams chosen shall be given to the captain of the opposing side not later than twelve hours before the time fixed for the commencement of play in each contest. The order of play, as regards Singles and Doubles respectively, shall be decided by the committee of management and announced not later than twenty-four hours before such notice is due.

11. If any player be absent when called upon to play by the referee, the opposing side shall be entitled to three love sets. Should, however, a player be incapacitated by illness, proved to the satisfaction of the referee, another member of the team can be substituted, provided the captain of the other team gives his consent.

12. The above regulations shall be binding upon the nations concerned, and shall not be altered except with the consent of two-thirds of the associations whose nations shall have from time to time competed and who shall record their votes.

## CHAMPIONSHIP REGULATIONS. 193

*Note.*—In the above regulations, one nation playing against another is regarded as a “tie”; Singles and Doubles are regarded as separate “contests,” and the best of five advantage sets is regarded as a “match.” The players in Singles and Doubles are regarded as separate “teams,” and the players in the combined contests as a “side.”

## REGULATIONS FOR THE MANAGEMENT OF LAWN TENNIS PRIZE-MEETINGS.

1. At prize-meetings promoted by associations or clubs affiliated to the Lawn Tennis Association, the laws of lawn tennis for the time being sanctioned by the Lawn Tennis Association, and the regulations hereinafter contained, shall be observed.

2. All details connected with any prize-meeting shall be settled by the committee of the club holding the meeting, or by a committee specially appointed for the purpose, of whom two, or such larger number as the committee shall determine, shall form a quorum.

3. A circular shall be issued by the committee specifying the conditions of the competition (*see* Recommendation 5).

4. No checks, orders for money, or cash payments in any form shall be given as prizes, and

## PRIZE-MEETING REGULATIONS. 195

the amount actually paid for each prize shall in no case be below the advertised value of the same.

5. The committee shall elect a referee, with power to appoint a substitute to be approved by them.

6. The referee, or such other member or members of the committee as may be selected for the purpose, shall have power to appoint umpires, and the referee shall decide any point of law which an umpire may profess himself unable to decide, or which may be referred to him on appeal from the decision of an umpire.

7. The referee shall, during the meeting, be *ex officio* a member of the committee.

8. The courts shall be allotted to the competitors, and the competitors shall be called upon to play, by a member or members of the committee, to be selected for the purpose, and in case of disagreement the committee shall decide.

9. The committee shall help to keep order on the ground and shall consult and decide on any question arising out of the competition, if summoned for that purpose by the referee or by any two of their number; and they shall have power,

when so convened, the misconduct of a competitor having been reported to them by a member of the committee or an umpire, to disqualify the offender, and further to order him off the ground, should his misconduct appear to them to justify such action, but before such action shall be taken, an opportunity of offering an explanation shall be afforded to the competitor whose misconduct has been reported to them.

10. It is the duty of an umpire—

- (a) To ascertain that the net is at the right height before the commencement of play, and to measure and adjust the net during play, if asked to do so, or if, in his opinion, its height has been altered,
- (b) To call the faults (subject to Regulation 11).
- (c) To call the strokes when won, or when he is asked to call them, and to record them on the umpire's scoring-sheet;
- (d) To call the games and the sets at the end of each, or when asked to call them; and to record them on the umpire's scoring-sheet;

# PRIZE-MEETING REGULATIONS. 197

*Example.*—The strokes are scored by means of pencil marks in the spaces beneath the word “STROKES,” thus:

Game	Initials of player	STROKES												Game won by			
1	AB	I	I		I	I											AB
	CD				I	I	I										
2	CD		I		I	I		I		I	I	I					CD
	AB	I		I			I	I									

The scoring-sheet shows that in the first game the score ran, and would have been called, thus: “15—love, 30—love, 30—15, 40—15, 40—30, game (AB),” in the second game, “love—15, 15 all, 15—30, 30 all, 40—30, deuce, advantage (CD), deuce, advantage (AD), deuce, advantage, (CD), game (CD).”

The score of the server should be called first.

**NOTE.**—At the end of each game the games should be called with the name of the player who is in advance, thus: “two games to one, B wins,” or, “B leads.” If the games are level the score should be called thus, “three games all,” or as the case may be. At the end of each set the sets should be called in like manner.

- (c) To direct competitors to change sides, in accordance with law 23;
- (f) When appealed to during a rest, whether a doubtful ball is "in play" or not, to call "play it out," and at the conclusion of the rest, to give his decision (subject to Regulation 11) or direct the competitors to play the stroke again;
- (g) To decide all doubtful or disputed strokes, and all points of law (subject to Regulations 11 and 12);
- (h) In handicap matches to call the odds at the commencement of each game; [see p. 199.]
- (i) To sign the umpire's scoring-sheets, and to deliver them at the conclusion of the match to such person as the committee may authorize to receive them;

Provided that no omission of any of the foregoing duties on the part of an umpire shall of itself invalidate a game or match.

11. It is the duty of a line-umpire to call faults and to decide strokes relating to the line for



# PRIZE-MEETING REGULATIONS. 199

In scoring handicap matches, the odds received should be marked by crosses on the right of the first perpendicular thick line before the commencement of each game, thus:

Game	Initials of players.	STROKES										Game won by	
1	AB	+											
	CD												
2	CD												
	AB	+	+										
3	AB	+											
	CD												
4	CD												
	AB	+	+										
5	AB	+											
	CD												
6	CD												
	AB	+	+										

[Here A B is receiving 15 and three-sixths of 15.

which he is appointed umpire, and to such line only.

12. The decision of an umpire shall be final



# PRIZE-MEETING REGULATIONS. 201

and crossed off one by one when the player owing wins a stroke, thus:

Game	Initials of Players	STROKES										Game won by	
1	A B	+	+										
	C D												
2	C D												
	A B		+										
3	A B	+	+										
	C D												
4	C D												
	A B		+										
5	A B		+										
	C D												
6	C D												
	A B		+										

Here A B owes 15 and two-sixths of 15.

13. The referee shall not bet on a match nor shall an umpire on a match in which he is acting, and if an objection for this or any other reason be made to a referee or umpire, either before or during the match, by a member of the committee

or a competitor, the match, if begun, shall, if necessary, be at once stopped by the referee or two members of the committee, who shall take the opinion of the committee on the objection, and the committee) shall not be at liberty to vote on pend the referee or umpire so objected to, provided that the decision of the majority of the committee present shall be final, and that the referee or umpire so objected to (if a member of the committee) shall not be at liberty to vote on the question.

14. No competitor may transfer his entry to another player.

15. Competitors shall have a right, by themselves or their deputies, to be present at the draw.

16. The draw shall be conducted in the following manner: Each competitor's name shall be written on a separate card or paper, and these shall be placed in a bowl or hat, drawn out by one at random, and copied on a list in the order in which they have been drawn.

17. When the number of competitors is 4, 8, 16, 32, 64, or any higher power of 2, they shall

# PRIZE-MEETING REGULATIONS. 203

meet in pairs, in accordance with the system shown by the following diagram :

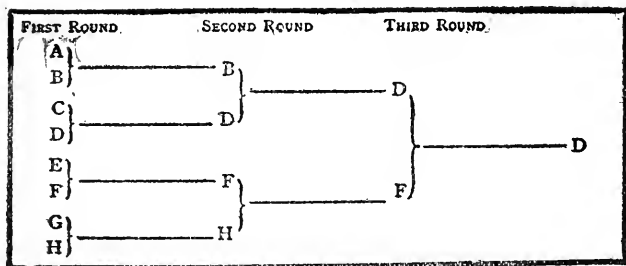

18. When the number of competitors is not a power of 2, there shall be byes in the first round. The number of byes shall be equal to the difference between the number of competitors and the next higher power of 2; and the number of pairs that shall meet in the first round shall be equal to the difference between the number of competitors and the next lower power of 2. The byes, if even in number, shall be divided, as the names are drawn, in equal proportions at the top and bottom of the list, above and below the pairs; if uneven in number, there shall be one more bye at the bottom than at the top. Thus, in

## SERIES 1.

*From 5 to 8 competitors.*

With 5, there will be 1 bye at the top and 2 byes at the bottom of the list, thus :

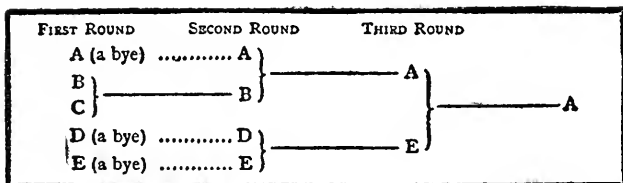

With 6, there will be 1 bye at the top, and 1 bye at the bottom.

With 7, 1 bye at the bottom.

With 8, no byes.

SERIES 2.

*From 9 to 16 competitors.*

With 9, 3 byes at the top, and 4 byes at the bottom, thus:

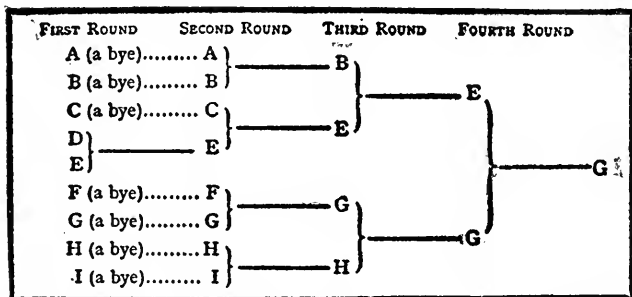

With 10, 3 byes at the top, and 3 byes at the bottom.

With 11, 2 byes at the top, and 3 byes at the bottom.

With 12, 2 byes at the top, and 2 byes at the bottom.

With 13, 1 bye at the top, and 2 byes at the bottom.

With 14, 1 bye at the top and 1 bye at the bottom.

With 15, 1 bye at the bottom.

With 16, no byes.

## SERIES 3.

*From 17 to 32 competitors.*

With 17, 7 byes at the top, and 8 byes at the bottom, thus:

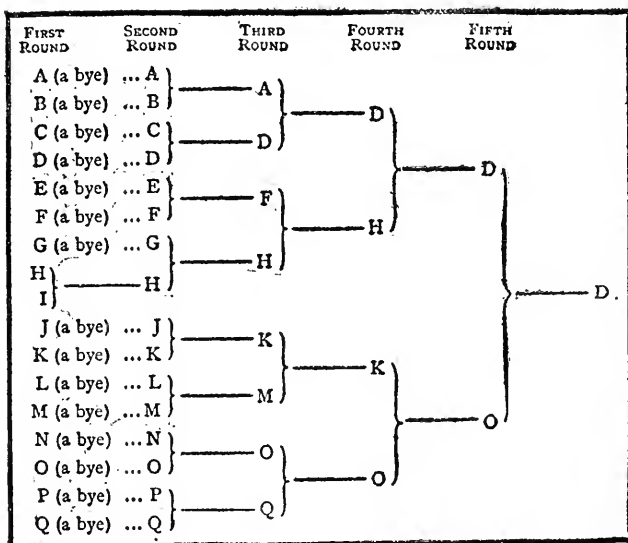

With 18, 7 byes at the top, and 7 byes at the bottom.

With 19, 6 byes at the top, and 7 byes at the bottom.



## PRIZE-MEETING REGULATIONS. 207

With 20, 6 byes at the top, and 6 byes at the bottom.

With 21, 5 byes at the top, and 6 byes at the bottom.

With 22, 5 byes at the top, and 5 byes at the bottom.

With 23, 4 byes at the top, and 5 byes at the bottom.

With 24, 4 byes at the top, and 4 byes at the bottom.

With 25, 3 byes at the top, and 4 byes at the bottom.

With 26, 3 byes at the top, and 3 byes at the bottom.

With 27, 2 byes at the top, and 3 byes at the bottom.

With 28, 2 byes at the top and 2 byes at the bottom.

With 29, 1 bye at the top, and 2 byes at the bottom.

With 30, 1 bye at the top, and 1 bye at the bottom.

With 31, 1 bye at the bottom.

With 32, no byes.

and so on, with larger numbers, in like manner.

19. If a competitor be absent when called on to play, or shall refuse to play, or shall have given previous notice to the referee, or member of the committee that he cannot play in his next round, his adversary shall win in that round.

20. In handicap matches the competitors shall be handicapped by the committee, or by a handicapper appointed by the committee.

21. Where the system of handicapping by sixths is used, the authorized tables of differential odds shall not be in any way altered or departed from, and unless any other principle of handicapping be adopted, the handicap shall be by classes, as below:—

Class 0 scratch.

“	1	receives one-sixth of 15.
“	2	“ two-sixths of 15.
“	3	“ three-sixths of 15.
“	4	“ four-sixths of 15.
“	5	“ five-sixths of 15.
“	6	“ 15.
“	7	“ 15 and one-sixth of 15.

## PRIZE-MEETING REGULATIONS. 209

Class	8	“	15 and two-sixths of 15.
	“	9	“ 15 and three-sixths of 15.
	“	10	“ 15 and four-sixths of 15.
	“	11	“ 15 and five-sixths of 15.
	“	12	“ 30.
	“	13	“ 30 and one-sixth of 15.
	“	14	“ 30 and two-sixths of 15.
	“	15	“ 30 and three-sixths of 15.
	“	16	“ 30 and four-sixths of 15.
	“	17	“ 30 and five-sixths of 15.
	“	18	“ 40.

When two players in different classes below scratch meet, the superior player shall start from scratch, and the odds received by the inferior player are as shown by the annexed table (No. I.). To use the table, find in the diagonal line of figures the number representing the class of the superior player, then travel along the corresponding horizontal column until the vertical column is reached which bears at the top the number of the class of the inferior player. The odds specified at the intersection of the two columns are the odds required.

HANDICAPS. Table No. 1, (Received Odds.)

When two players, both for receipt of odds, meet, the player receiving the smaller odds is put back to scratch. The following table shows the point at which the other should then start. The number at the left of the horizontal columns denotes the player who goes back to scratch, those at the head of the vertical columns the player who still receives odds; and the numbers within the columns show the odds to be received by the player whose number stands at the head of the column.

	1	2	3	4	5	6.	7	8	9	10	11	12	13	14	15	16.	17	18	
1		$\frac{1}{2}$ of 15.	$\frac{1}{2}$ of 15.	$\frac{1}{2}$ of 15.	$\frac{1}{2}$ of 15.	$\frac{1}{2}$ of 15.	$\frac{1}{2}$ of 15.	$\frac{1}{2}$ of 15.	$\frac{1}{2}$ of 15.	$\frac{1}{2}$ of 15.	$\frac{1}{2}$ of 15.	$\frac{1}{2}$ of 15.	$\frac{1}{2}$ of 15.	$\frac{1}{2}$ of 15.	$\frac{1}{2}$ of 15.	$\frac{1}{2}$ of 15.	$\frac{1}{2}$ of 15.	$\frac{1}{2}$ of 15.	
2			$\frac{1}{2}$ of 15.	$\frac{1}{2}$ of 15.	$\frac{1}{2}$ of 15.	$\frac{1}{2}$ of 15.	$\frac{1}{2}$ of 15.	$\frac{1}{2}$ of 15.	$\frac{1}{2}$ of 15.	$\frac{1}{2}$ of 15.	$\frac{1}{2}$ of 15.	$\frac{1}{2}$ of 15.	$\frac{1}{2}$ of 15.	$\frac{1}{2}$ of 15.	$\frac{1}{2}$ of 15.	$\frac{1}{2}$ of 15.	$\frac{1}{2}$ of 15.	$\frac{1}{2}$ of 15.	
3				$\frac{1}{2}$ of 15.	$\frac{1}{2}$ of 15.	$\frac{1}{2}$ of 15.	$\frac{1}{2}$ of 15.	$\frac{1}{2}$ of 15.	$\frac{1}{2}$ of 15.	$\frac{1}{2}$ of 15.	$\frac{1}{2}$ of 15.	$\frac{1}{2}$ of 15.	$\frac{1}{2}$ of 15.	$\frac{1}{2}$ of 15.	$\frac{1}{2}$ of 15.	$\frac{1}{2}$ of 15.	$\frac{1}{2}$ of 15.	$\frac{1}{2}$ of 15.	
4					$\frac{1}{2}$ of 15.	$\frac{1}{2}$ of 15.	$\frac{1}{2}$ of 15.	$\frac{1}{2}$ of 15.	$\frac{1}{2}$ of 15.	$\frac{1}{2}$ of 15.	$\frac{1}{2}$ of 15.	$\frac{1}{2}$ of 15.	$\frac{1}{2}$ of 15.	$\frac{1}{2}$ of 15.	$\frac{1}{2}$ of 15.	$\frac{1}{2}$ of 15.	$\frac{1}{2}$ of 15.	$\frac{1}{2}$ of 15.	
5						$\frac{1}{2}$ of 15.	$\frac{1}{2}$ of 15.	$\frac{1}{2}$ of 15.	$\frac{1}{2}$ of 15.	$\frac{1}{2}$ of 15.	$\frac{1}{2}$ of 15.	$\frac{1}{2}$ of 15.	$\frac{1}{2}$ of 15.	$\frac{1}{2}$ of 15.	$\frac{1}{2}$ of 15.	$\frac{1}{2}$ of 15.	$\frac{1}{2}$ of 15.	$\frac{1}{2}$ of 15.	
6							$\frac{1}{2}$ of 15.	$\frac{1}{2}$ of 15.	$\frac{1}{2}$ of 15.	$\frac{1}{2}$ of 15.	$\frac{1}{2}$ of 15.	$\frac{1}{2}$ of 15.	$\frac{1}{2}$ of 15.	$\frac{1}{2}$ of 15.	$\frac{1}{2}$ of 15.	$\frac{1}{2}$ of 15.	$\frac{1}{2}$ of 15.	$\frac{1}{2}$ of 15.	
7								$\frac{1}{2}$ of 15.	$\frac{1}{2}$ of 15.	$\frac{1}{2}$ of 15.	$\frac{1}{2}$ of 15.	$\frac{1}{2}$ of 15.	$\frac{1}{2}$ of 15.	$\frac{1}{2}$ of 15.	$\frac{1}{2}$ of 15.	$\frac{1}{2}$ of 15.	$\frac{1}{2}$ of 15.	$\frac{1}{2}$ of 15.	
8									$\frac{1}{2}$ of 15.	$\frac{1}{2}$ of 15.	$\frac{1}{2}$ of 15.	$\frac{1}{2}$ of 15.	$\frac{1}{2}$ of 15.	$\frac{1}{2}$ of 15.	$\frac{1}{2}$ of 15.	$\frac{1}{2}$ of 15.	$\frac{1}{2}$ of 15.	$\frac{1}{2}$ of 15.	
9										$\frac{1}{2}$ of 15.	$\frac{1}{2}$ of 15.	$\frac{1}{2}$ of 15.	$\frac{1}{2}$ of 15.	$\frac{1}{2}$ of 15.	$\frac{1}{2}$ of 15.	$\frac{1}{2}$ of 15.	$\frac{1}{2}$ of 15.	$\frac{1}{2}$ of 15.	
10											$\frac{1}{2}$ of 15.	$\frac{1}{2}$ of 15.	$\frac{1}{2}$ of 15.	$\frac{1}{2}$ of 15.	$\frac{1}{2}$ of 15.	$\frac{1}{2}$ of 15.	$\frac{1}{2}$ of 15.	$\frac{1}{2}$ of 15.	
11												$\frac{1}{2}$ of 15.	$\frac{1}{2}$ of 15.	$\frac{1}{2}$ of 15.	$\frac{1}{2}$ of 15.	$\frac{1}{2}$ of 15.	$\frac{1}{2}$ of 15.	$\frac{1}{2}$ of 15.	
12													$\frac{1}{2}$ of 15.	$\frac{1}{2}$ of 15.	$\frac{1}{2}$ of 15.	$\frac{1}{2}$ of 15.	$\frac{1}{2}$ of 15.	$\frac{1}{2}$ of 15.	
13														$\frac{1}{2}$ of 15.	$\frac{1}{2}$ of 15.	$\frac{1}{2}$ of 15.	$\frac{1}{2}$ of 15.	$\frac{1}{2}$ of 15.	
14															$\frac{1}{2}$ of 15.	$\frac{1}{2}$ of 15.	$\frac{1}{2}$ of 15.	$\frac{1}{2}$ of 15.	
15																$\frac{1}{2}$ of 15.	$\frac{1}{2}$ of 15.	$\frac{1}{2}$ of 15.	
16																	$\frac{1}{2}$ of 15.	$\frac{1}{2}$ of 15.	$\frac{1}{2}$ of 15.
17																		$\frac{1}{2}$ of 15.	$\frac{1}{2}$ of 15.
18																			$\frac{1}{2}$ of 15.

This table was calculated upon the following data :—  
In the case of received odds

The average value of  $\frac{1}{2}$  is .2024.  
" " " " is .3552.  
" " " " is .4811.  
" " " " is .6069.  
" " " " is .7841.

" length of a game is 4.6256 strokes.  
" 15:1 means 15 and one-sixth of 15 and so on.

**HANDICAPS. Table No. II. (Owed Odds.)**

When two players meet who are handicapped to *own* odds, the player owing the lesser odds is placed at scratch. This table shows the odds the other will still owe!—

1	2	3	4	5	6	7	8	9	10	11	12	13	14	15	16	17	18
$\frac{1}{2}$ of 15	$\frac{1}{2}$ of 15	$\frac{1}{2}$ of 15	$\frac{1}{2}$ of 15	$\frac{1}{2}$ of 15	15	15.1	15.2	15.3	15.4	15.5	30.	30.1	30.2	30.3	30.4	30.5	40.
1	$\frac{1}{2}$ of 15	$\frac{1}{2}$ of 15	$\frac{1}{2}$ of 15	$\frac{1}{2}$ of 15	$\frac{1}{2}$ of 15	15.	15.1	15.2	15.3	15.4	15.5	30.	30.	30.1	30.2	30.3	30.4
2	$\frac{1}{2}$ of 15	$\frac{1}{2}$ of 15	$\frac{1}{2}$ of 15	$\frac{1}{2}$ of 15	$\frac{1}{2}$ of 15	$\frac{1}{2}$ of 15	15.	15.	15.1	15.2	15.3	15.4	15.5	30.	30.	30.1	30.2
	3	$\frac{1}{2}$ of 15	$\frac{1}{2}$ of 15	$\frac{1}{2}$ of 15	$\frac{1}{2}$ of 15	$\frac{1}{2}$ of 15	$\frac{1}{2}$ of 15	15.	15.	15.1	15.2	15.3	15.4	15.5	30.	30.	30.1
		4	$\frac{1}{2}$ of 15	$\frac{1}{2}$ of 15	$\frac{1}{2}$ of 15	$\frac{1}{2}$ of 15	$\frac{1}{2}$ of 15	$\frac{1}{2}$ of 15	15.	15.	15.1	15.2	15.3	15.4	15.5	30.	30.1
			5	$\frac{1}{2}$ of 15	$\frac{1}{2}$ of 15	$\frac{1}{2}$ of 15	$\frac{1}{2}$ of 15	$\frac{1}{2}$ of 15	$\frac{1}{2}$ of 15	15.	15.	15.1	15.2	15.3	15.4	15.5	30.
				6	$\frac{1}{2}$ of 15	$\frac{1}{2}$ of 15	$\frac{1}{2}$ of 15	$\frac{1}{2}$ of 15	$\frac{1}{2}$ of 15	$\frac{1}{2}$ of 15	15.	15.	15.1	15.2	15.3	15.4	15.5
					7	$\frac{1}{2}$ of 15	$\frac{1}{2}$ of 15	$\frac{1}{2}$ of 15	$\frac{1}{2}$ of 15	$\frac{1}{2}$ of 15	$\frac{1}{2}$ of 15	15.	15.	15.1	15.2	15.3	15.4
						8	$\frac{1}{2}$ of 15	$\frac{1}{2}$ of 15	$\frac{1}{2}$ of 15	$\frac{1}{2}$ of 15	$\frac{1}{2}$ of 15	$\frac{1}{2}$ of 15	15.	15.	15.1	15.2	15.3
							9	$\frac{1}{2}$ of 15	$\frac{1}{2}$ of 15	$\frac{1}{2}$ of 15	$\frac{1}{2}$ of 15	$\frac{1}{2}$ of 15	$\frac{1}{2}$ of 15	$\frac{1}{2}$ of 15	15.	15.1	15.2
								10	$\frac{1}{2}$ of 15	$\frac{1}{2}$ of 15	$\frac{1}{2}$ of 15	$\frac{1}{2}$ of 15	$\frac{1}{2}$ of 15	$\frac{1}{2}$ of 15	$\frac{1}{2}$ of 15	15.	15.1
									11	$\frac{1}{2}$ of 15	$\frac{1}{2}$ of 15	$\frac{1}{2}$ of 15	$\frac{1}{2}$ of 15	$\frac{1}{2}$ of 15	$\frac{1}{2}$ of 15	$\frac{1}{2}$ of 15	15.
										12	$\frac{1}{2}$ of 15	$\frac{1}{2}$ of 15	$\frac{1}{2}$ of 15	$\frac{1}{2}$ of 15	$\frac{1}{2}$ of 15	$\frac{1}{2}$ of 15	15.
											13	$\frac{1}{2}$ of 15	$\frac{1}{2}$ of 15	$\frac{1}{2}$ of 15	$\frac{1}{2}$ of 15	$\frac{1}{2}$ of 15	15.
												14	$\frac{1}{2}$ of 15	$\frac{1}{2}$ of 15	$\frac{1}{2}$ of 15	$\frac{1}{2}$ of 15	15.
													15	$\frac{1}{2}$ of 15	$\frac{1}{2}$ of 15	$\frac{1}{2}$ of 15	15.
														16	$\frac{1}{2}$ of 15	$\frac{1}{2}$ of 15	15.
															17	$\frac{1}{2}$ of 15	15.

This table has been calculated upon the following data:—

- In the case of owed odds
- The average value of  $\frac{1}{2}$  is 2158.
- " " " " is 3229.
- " " " " is 5188.
- " " " " is 6448.
- " " " " is 7975.

Length of a game is 46250 strokes; using this table, supply throughout the word 'one' before the odds specified.

*Example.*—If class 3 has to meet class 9, start from the figure 3 in the diagonal line of figures, and look horizontally until the vertical column is reached headed by the figure 9. The odds given at the point of intersection of the two columns (viz., 15 and one-sixth of 15) are the odds required.

When the difference between the best and worst players is great (say more than 30), it is desirable to handicap the best players at *owed* odds. The players above scratch (*i.e.*, owing odds) should be classified as follows: —

Class 1	owes	one-sixth	of 15.
“ 2	“	two-sixths	of 15.
“ 3	“	three-sixths	of 15.
“ 4	“	four-sixths	of 15.
“ 5	“	five-sixths	of 15.
“ 6	“	15.	
“ 7	“	15 and one-sixth	of 15.
“ 8	“	15 and two-sixths	of 15.
“ 9	“	15 and three-sixths	of 15.
“ 10	“	15 and four-sixths	of 15.
“ 11	“	15 and five-sixths	of 15.

## PRIZE-MEETING REGULATIONS. 213

Class 12 “ 30.

“ 13 “ 30 and one-sixth of 15.

“ 14 “ 30 and two-sixths of 15.

“ 15 “ 30 and three-sixths of 15.

“ 16 “ 30 and four-sixths of 15.

“ 17 “ 30 and five-sixths of 15.

“ 18 “ 40.

When the two players in different classes above scratch meet, the inferior player shall start from scratch, and the odds owed by the superior player are as shown by the annexed table (No. II.).

This table is to be used in the same way as the former, the class of the superior player being looked for in the horizontal line of figures at the top, and the class of the inferior player in the diagonal line of figures.

*Example.*—If class 12 (owe 30) meet class 7 (owe 15 and one-sixth of 15), the former must owe the latter the odds of four-sixths of 15.

22. In championship matches and handicap by classes, as above, advantage-sets shall be played throughout the ties.

23. The committee may, whether appealed to

by any competitor or not, postpone the meeting or any match or part of a match if, in their opinion, the state of the weather or of the light, or condition of the ground, or other circumstances, render it advisable to do so.



## RECOMMENDATIONS.

1. There should be, if possible, a clear margin of at least 12 feet on each side, and 21 feet at each end of the court; or, between adjacent courts, 18 feet on each side; but should the courts be placed end to end, or end to side, there should be spaces of 42 feet or 33 feet respectively and a stop net at least 8 feet high between.

2. Should the referee be a competitor, a substitute should be appointed to act for him while he is playing.

3. If two or more prizes be given, the loser in the final tie should receive the second prize, and where more than two prizes are given, the losers in the last tie but one should receive prizes of equal value.

4. In important matches it is desirable to have seven line-umpires in addition to the scoring

umpire—namely, one for each base-line, one for each service-line, one for the half-court-line, and one for each side-line.

5. The circular issued by the committee should include the following particulars :

- (1) The date, hour, and place of meeting ;
- (2) The events, entrance fees, and value of the prizes ;
- (3) The date, hour, and place of receiving and closing the entries ;
- (4) The time and place of the draw ;
- (5) The maker's name of the balls to be used at the meeting ;
- (6) The shoes to be worn, if there be any restriction in this respect ;
- (7) The number of sets to be played in the various matches, and whether advantage-sets or not.

6. In handicap competitions the handicap should, if possible, be framed before the draw takes place.

## LAWS OF THE GAME.

---

  
THE SINGLE-HANDED GAME.

1. For the single-handed game the court is 27 feet in width and 78 feet in length. It is divided across the middle by a net, the ends of which are attached to the tops of two posts which stand 3 feet outside the court on each side. The height of the net is 3 feet 6 inches at the posts and 3 feet at the centre. At each end of the court parallel with the net and at a distance of 39 feet from it, are drawn the *base-lines*, the extremities of which are connected by the *side-lines*. Half-way between the side-lines, and parallel with them, is drawn the *half-court-line*, dividing the space on each side of the net into two equal parts called the *right* and *left courts*. On each side of the

net, at a distance of 21 feet from it and parallel with it, are drawn the *service-lines*. The marking of the part of the *half-court-line* between the *service-lines* and the *base-lines* may be omitted, with the exception of a small portion at the centre of each *base-line*, as indicated in the plans appended to these laws.

2. The balls shall not be less than  $2\frac{1}{2}$  inches, nor more than  $2\frac{9}{16}$  inches in diameter, and not less than 1 ounce, nor more than 2 ounces in weight.

3. In matches where umpires are appointed, their decision shall be final; but where a referee is appointed, an appeal shall lie to him from the decision of an umpire on a question of law.

4. The choice of sides and the right to be server or striker-out during the first games shall be decided by toss; provided that, if the winner of the toss choose the right to be server or striker-out, the other player shall have the choice of sides, and *vice versa*; and provided that the winner of the toss may, if he prefer it, require the other player to make the first choice.

5. The players shall stand on opposite sides

of the net; the player who first delivers the ball shall be called the *server*, the other the *striker-out*.

6. At the end of the first game the striker-out shall become server, and the server shall become striker-out; and so on alternately in the subsequent games of the set.

7. The server shall serve with both feet behind (*i.e.*, further from the net than) the base-line, and within the limits of the imaginary continuation of the centre service and the side-lines. It is not a fault if one only of the server's feet do not touch the ground at the moment at which the service is delivered. He shall place both feet on the ground immediately before serving and shall not take a running or walking start. He shall deliver the service from the right and left courts alternately, beginning from the right in each of his service games, even though the odds be given or owed.

8. The ball served must drop within the service-line, half-court-line, and side-line of the court which is diagonally opposite to that from which it was served, or upon any such line.

9. It is a *fault* if the service be delivered from the wrong court, or if the server do not stand as directed in Law 7, or if the ball served drop in the net or beyond the service-line, or if it drop out of court or in the wrong court. If the server in attempting to serve miss the ball altogether, it does not count a fault, but if the ball be touched (no matter how slightly) by the racket, a service is thereby delivered and the laws governing the service at once apply.

10. A fault may not be taken.

11. After a fault the server shall serve again from the same court from which he served that fault, unless it was a fault because served from the wrong court.

12. A fault may not be claimed after the next service has been delivered.

13. The service may not be volleyed, *i.e.*, taken before it touches the ground, even though the ball be clearly outside the service-court.

14. The server shall not serve until the striker-out be ready. If the latter attempt to return the service but fail, he loses the stroke. If however the striker-out signify that he is not ready after

the service has been delivered, but before the ball touch the ground, he may not claim a fault because the ball ultimately drops outside the service-court.

15. A ball is *in play* from the moment at which it is delivered in service (unless a fault) until it has been volleyed by the striker-out in his first stroke, or has dropped in the net or out of court, or has touched either of the players or anything that he wears or carries (except his racket in the act of striking), or has been struck by either of the players with his racket more than once consecutively, or has been volleyed before it has passed over the net, or has failed to pass over the net before its first bound (except as provided in Law 17), or has touched the ground twice consecutively on either side of the net, though the second time may be out of court.

16. It is a "let" if the ball served touch the net, provided the service be otherwise good; or if a service or fault be delivered when the striker-out is not ready. In case a player is obstructed by any accident not within his control the ball shall be considered a let; but where a permanent fix-

ture of the court is the cause of the accident the point shall be counted—benches and chairs placed round the court and their occupants and the umpire and linesmen shall be considered permanent fixtures. If however a ball in play strike a permanent fixture of the court (other than the net or posts) before it touches the ground the point is lost; if after it has touched the ground, the point shall be counted. In case of a let, the service or stroke counts for nothing and the server shall serve again. A let does not annul a previous fault.

17. It is a good return :

- (a) If a ball touch the net or post provided that it passes over either and drops into the court ;
- (b) If a ball served or returned drop into the proper court and screw or be blown back over the net and the player whose turn it is to strike reach over the net and play the ball, provided that neither he nor any part of his clothes or racket touch the net and that the stroke be otherwise good ;



- (c) If a ball be returned outside the post either above or below the level of the top of the net, even though it touch the post, provided that it drop into the proper court;
- (d) If a player's racket pass over the net after he has returned the ball, provided the ball pass over the net before being played and be properly returned;
- (e) If a player succeed in returning a ball, served or in play which strikes a ball lying in the court.

18. The server wins a stroke if the striker-out volleyed a service, or failed to return the service or the ball in play (except in the case of a let), or return the service or ball in play so that it drop outside any of the lines which bound his opponent's court, or otherwise lose a stroke, as provided by Law 20.

19. The striker-out wins a stroke if the server serve two consecutive faults, or fail to return the ball in play (except in the case of a let), or return the ball in play so that it drop outside any

of the lines which bound his opponent's court, or otherwise lose a stroke, as provided by Law 20.

20. Either player loses a stroke if the ball in play touch him or anything that he wears or carries, except his racket in the act of striking; or if he volley the ball (unless he thereby makes a good return) no matter whether he is standing within the limits of the court or outside them; or if he touch or strike the ball in play with his racket more than once consecutively; or if he or his racket (in his hand or otherwise) touch the net or any of its supports while the ball is in play; or if he volley the ball before it has passed the net.

21. On either player winning his first stroke, the score is called 15 for that player; on either player winning his second stroke, the score is called 30 for that player; on either player winning his third stroke the score is called 40 for that player; and the fourth stroke won by either player is scored game for that player; except as below:

If both players have won three strokes, the score is called deuce; and the next stroke

won by either player is scored advantage for that player. If the same player win the next stroke, he wins the game; if he lose the next stroke, the score is again called deuce; and so on until either player win the two strokes immediately following the score at deuce, when the game is scored to that player.

22. The player who first wins six games wins a set; except as below:

If both players win five games, the score is called games all; and the next game won by either player is scored advantage-game for that player. If the same player win the next game, he wins the set; if he lose the next game, the score is again called games all; and so on, until either player win the two games immediately following the score of games all, when he wins the set.

NOTE.—Players may agree not to play advantage-sets but to decide the set by one game after arriving at the score of games all.

23. The players shall change sides at the end of the first, third, and every subsequent alternate game of each set, and at the end of each set, un-

less the number of games in such set be even. It shall, however, be open to the players by mutual consent and notification to the umpire before the opening of the second game of the match to change sides instead at the end of every set, until the odd and concluding set, in which they shall change sides at the end of the first, third, and every subsequent alternate game of such set.

24. When a series of sets is played the player who was server in the last game of one set shall be striker-out in the first game of the next.

#### ODDS.

25. In the case of received odds:

- (a) One-sixth of 15 is one stroke given in every six games of a set in the position shown by the annexed table;
- (b) Similarly, two-sixths, three-sixths, four-sixths, and five-sixths of 15 are respectively two, three, four, and five strokes given in every six games of a set in the position shown by the table:

	First Game	Second Game	Third Game	Fourth Game	Fifth Game	Sixth Game
One-sixth of 15 . .	0	15	0	0	0	0
Two-sixths of 15 . .	0	15	0	15	0	0
Three-sixths of 15 . .	0	15	0	15	0	15
Four-sixths of 15 . .	0	15	0	15	15	15
Five-sixths of 15 . .	0	15	15	15	15	15

*Example.*—A player receiving four-sixths of 15 receives nothing in the first and third games, and 15 in the second, fourth, fifth, and sixth games of a set.

*NOTE.*—The table is not carried beyond the sixth game, as in the next and every succeeding six games the odds recur in the same positions.

(c) The above odds may be given in augmentation of other receiving odds;

(d) Fifteen is one stroke given at the beginning of every game of a set;

(e) Thirty is two strokes given at the beginning of every game of a set;

(f) Forty is three strokes given at the beginning of every game of a set;

26. In the case of owed odds:

(a) One-sixth of 15 is one stroke owed in

every six games of a set in the position shown by the annexed table.

(b) Similarly, two-sixths, three-sixths, four-sixths, and five-sixths of 15 are respectively two, three, four, and five strokes owed in every six games of a set in the position shown by the following table :

	First Game	Second Game	Third Game	Fourth Game	Fifth Game	Sixth Game
One-sixth of 15 . .	15	0	0	0	0	0
Two-sixths of 15 . .	15	0	15	0	0	0
Three-sixths of 15 . .	15	0	15	0	15	0
Fourth-sixths of 15 . .	15	0	15	0	15	15
Five-sixths of 15 . .	15	0	15	15	15	15

*Example.*—A player owing two-sixths of 15 would owe 15 in the first and third games, and nothing in the second, fourth, fifth, and sixth games.

*NOTE.*—The table is not carried beyond the sixth game, as in the next and every succeeding six games the odds recur in the same positions.

(c) The above odds may be owed in augmentation of other owed odds;

- (d) Fifteen is one stroke owed at the beginning of every game of a set;
- (e) Thirty is two strokes owed at the beginning of every game of a set;
- (f) Forty is three strokes owed at the beginning of every game of a set.

---

### THE THREE-HANDED AND FOUR-HANDED GAMES.

27. The above laws shall apply to the three-handed and four-handed games except as below:

28. For the three-handed and four-handed games, the court is 36 feet in width. Within the side-lines at a distance of  $4\frac{1}{2}$  feet from them and parallel with them, are drawn the service-side lines. In other respects the court is similar to that which is described in Law 1.

29. In the three-handed game the single player shall serve in every alternate game.

30. In the four-handed game the pair who have the right to serve in the first game may decide which partner shall do so, and the opposing pair may decide similarly for the second game. The partner of the player who served in the first

game shall serve in the third; and the partner of the player who served in the second game shall serve in the fourth, and so on in the same order in all the subsequent games of a set.

31. The players shall take the service alternately throughout each game, no player shall receive or return a service delivered to his partner, and the order of service and of striking-out, once arranged, shall not be altered nor shall the striker-out change courts to receive the service, before the end of the set.

32. The ball served must drop within the service-line half-court-line, and service side-line of the court, which is diagonally opposite to that from which it was served, or upon any such line.

33. It is a *fault* if the ball do not drop as provided in Law 32, or if it touch the server's partner, or anything that he wears or carries. If, however, the ball in service strike either the striker-out or his partner, the server wins the stroke.

34. If a player serve out of his turn, the umpire, as soon as the mistake is discovered by himself or by one of the players, shall direct the



player to serve who ought to have served; but all strokes scored, and any fault served before such discovery shall be reckoned. If a game shall have been completed before such discovery,

PLANS OF COURTS.

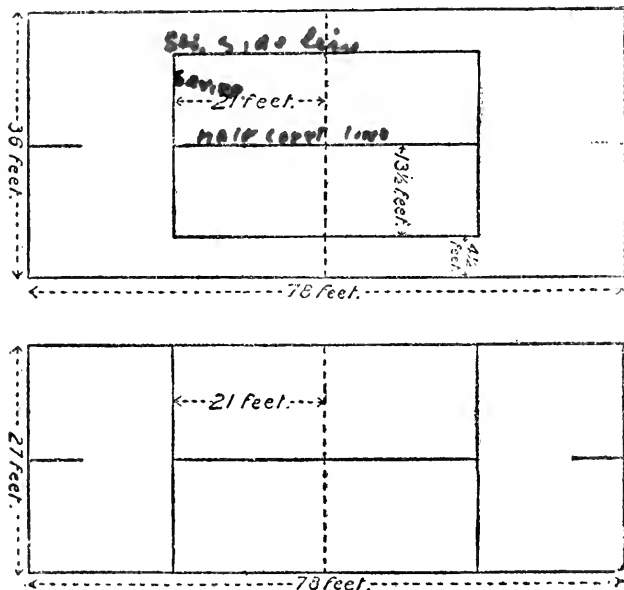

then the service in the next alternate game shall be delivered by the partner of the player who served out of his turn; and so on in regular rotation.

## KNOTTY POINTS.

## ADDENDA TO THE LAWS OF THE GAME.

*Revised and approved by the Council of the  
Lawn Tennis Association.*

1. If a player throws his racket at the ball and so returns the ball into the proper court, he loses the stroke.

2. If a player catches the ball on his racket, walks with it to the net, and, reaching over, drops it into court, he loses the stroke, as such a proceeding cannot be defined as an "act of striking" (*vide* Law 15).

3. If a player, to avoid touching the net, jumps over it while the ball is in play, he loses the stroke.

4. If an umpire erroneously calls "fault," and at once corrects himself and cries "play," and the striker-out fails to return the ball, a "let" must be allowed.

5. If in a Double game the server's service

strikes *either* of his opponents, he wins the stroke.

6. If a match is postponed on account of rain or darkness coming on or for any similar reason, and is continued on the subsequent day, the match shall be resumed from the point where it was discontinued on the previous day. An entirely new commencement may only be made with the consent of the referee.

7. If two players in a handicap play at the wrong odds, the match stands, unless they have been wrongly instructed by the referee, or any person or persons acting under his instructions, in which case the loser may claim to have the match replayed, unless the mistake in the odds has been in his favor. Such claim must be made within a reasonable time.

8. A similar decision must be given if two players neglect to play advantage-sets when one of the conditions of the event in which they are competing is that advantage-sets should be played.









JUL 18 1949

JAN 1934

JAN 10 1947  
APR 28 1947

MAY 12 1947

SEP 8 1929

NOV 23 1934

JUN 6 1947  
JUL 28 1947

JUN 23 1930

MAY 1 1934  
MAY 5 1935

JUL 30 1947

JUN 30

NOV 16 1935

DEC 9 1947

JAN 2 1931

NOV 16 1935

FEB 5 - 1948

MAY 10 1931

JAN 3 1938  
JAN 21 1938

OCT 30 1950

JUN 30

MAY 21 1957

JUN 22 1945

DEC 20 1957

AUG 17 1945

AUG 10 1945  
DEC 10 1945



6c



3 1158 00316 5718

UC SOUTHERN REGIONAL LIBRARY FACILITY



**AA** 001 167 847 1

UNIVERSITY OF CALIFORNIA

AT

LOS ANGELES

LIBRARY

UNIVERSITY OF CALIFORNIA LIBRARY  
Los Angeles  
This book is DUE on the last date stamped below.

LD-URL

LD  
URL

MAR

7 '77

REC'D LD-URL

*LD-URL*  
NOV 03 1988

*April 22*  
*1977*

6c



3 1158 00316 5718

UC SOUTHERN REGIONAL LIBRARY FACILITY



**AA** 001 167 847 1

UNIVERSITY OF CALIFORNIA

LOS ANGELES

LIBRARY

