

3. AL 1
2 B 62

ROENTGENS, *rads,* AND RIDDLES

A Symposium on Supervoltage Radiation Therapy



U. S. FEDERAL
DOCUMENT
Wis. State College Oshkosh
Library AUG 24 1959

UNITED STATES ATOMIC ENERGY COMMISSION
1959

From the collection of the

o P^zreⁿL^minger^a
v Library
t p

San Francisco, California
2007

ROENTGENS,
rads,
AND
RIDDLES

Edited by
MILTON FRIEDMAN, M.D.,
MARSHALL BRUCER, M.D.,
and
ELIZABETH ANDERSON

*Oak Ridge
Institute of Nuclear Studies
Oak Ridge, Tennessee*

U. S. ATOMIC ENERGY COMMISSION

A
Symposium
on Supervoltage
Radiation
Therapy

Held
at the
Medical
Division,
Oak Ridge
Institute
of Nuclear
Studies

July 15, 16, 17,
and
18, 1956

LEGAL NOTICE

This document was prepared under the sponsorship of the U. S. Atomic Energy Commission. Neither the United States, nor the Commission, nor any person acting on behalf of the Commission:

A. Makes any warranty or representation, express or implied, with respect to the accuracy, completeness, or usefulness of the information contained in this document, or that the use of any information, apparatus, method, or process disclosed in this document may not infringe privately owned rights; or

B. Assumes any liabilities with respect to the use of, or for damages resulting from the use of any information, apparatus, method, or process disclosed in this document.

As used in the above, "person acting on behalf of the Commission" includes any employee or contractor of the Commission to the extent that such employee or contractor prepares, handles or distributes, or provides access to, any information pursuant to his employment or contract with the Commission.

PREFACE

In October 1948, even before the Medical Division of the Oak Ridge Institute of Nuclear Studies was officially organized, the subject of supervoltage radiation had been discussed. Our initial interest was stimulated by Leonard G. Grimmett, an English physicist, who foresaw the potentialities of Co^{60} as soon as he heard about the nuclear reactor. Unfortunately Dr. Grimmett died one month before the first supervoltage Co^{60} machine was installed.

Since 1950, Co^{60} supervoltage has been a topic of major interest, but this has not been an independent effort of the staff of the Medical Division. We have been under a constant bombardment of ideas from advisors from almost half the medical schools of the United States, Canada, England, New Zealand, and Australia. Most of the ideas that have been developed at the Medical Division have been the result of this cross-fertilization.

In 1952, the Teletherapy Evaluation Program was organized to help direct the efforts of the Medical Division. Twenty-two medical schools maintained a constant interest and gave generous financial support to the prototype hectocurie Co^{60} unit and the first Cs^{137} unit.

A series of industrial conferences was held on open invitation to all the potential manufacturers of supervoltage equipment in the United States, Canada, and England. These conferences resulted in the adoption in 1953 of a standardized capsule for Co^{60} sources.

In 1955, an informal group of therapists began discussions at ORINS on the use of isotopes in the fertile field of brachytherapy.

By early 1956, the problems of isotope machine design, production of sources, and the beginnings of clinical therapy were well under way. Instead of one or two interested groups, almost every active supervoltage research center was developing its own ideas. From a very small spark of interest, the idea was rapidly developing into a major commercial business. The common thread throughout this entire development was supervoltage therapy. It was felt that it was time to review the entire field.

When the announcement was made in Copenhagen in 1953 that the Eighth International Congress of Radiology would be held in Mexico City, Dr. Milton Friedman of New York said it would be wonderful to have some excuse to have this world-wide gathering of therapists stop by in Oak Ridge en route to Mexico City. This idea grew, and early in 1956 the United States Atomic Energy Commission approved a plan for inviting teletherapists from the rest of the world. Doctors C. B. Braestrup, M. Brucer, M. Friedman, R. Loevinger, and N. Simon met in New York and organized a seminar on supervoltage to be held in Oak Ridge immediately before the Eighth International Congress in Mexico City in July 1956.

The plan was to have a seminar on opinions regarding supervoltage. An attempt was made to invite speakers familiar with as many kinds of supervoltage equipment as were available. Some speakers were invited because they had not used any kind of supervoltage equipment. The seminar was organized as one of the final formal meetings of the Tele-

PREFACE

therapy Evaluation Program. The speakers were specifically advised that we were not particularly interested in new research or in gathering facts but rather in bringing together the opinion of a diverse body of experience.

The proceedings of the seminar were stenotyped; then all the participants were given an opportunity to edit their own transcripts. The volume of talk in four days was tremendous. The manuscript was further edited to reduce its size. Throughout the editing an attempt has been made to keep the flavor of the spoken seminar rather than to emphasize a polished rewriting of statements of fact. Where the repetition of well-known facts interfered with an interesting opinion, the opinion has been given priority.

An appendix has been added which is somewhat factual. This addition has been made because these items were constantly referred to throughout the seminar. Also, we could not resist including a little Cs¹³⁷.

Because of the large number of authors and the demand for a reasonably early publication, it has been impossible for the final copy to be checked by each author. The editors accept responsibility for any errors of fact that have been allowed to persist and for any new ones that may have crept in. We do not recognize that there are such things as errors of opinion because all the authors are mature scientists and well qualified to express themselves.

Since this is a document that stresses opinion rather than fact and since opinion is valuable only when it contains all the spice and flavor of a full article, we have made no attempt to index this volume. The table of contents has been expanded to enable the reader to find who is expressing his opinion where.

The participants in the seminar were instructed not to read a documented formal presentation; therefore no chapter references were required. A bibliography was subsequently constructed by asking each participant to list the documents most important for his students to read.

We are grateful to the United States Atomic Energy Commission for most of the financial support for the Teletherapy Evaluation Program. This book was prepared for publication by the Publishing Branch, Technical Information Service Extension, USAEC, Oak Ridge.

Only another editor can realize how many persons help in preparing a symposium and how impossible it would be to build the book without them. Dr. Friedman's secretaries, Hanne Westergaard and Elissa Zachowitz, retyped much of the material and wrote countless letters. Nelda Edwards and Norma Munsey in the Medical Division office also retyped several chapters and handled a tremendous amount of correspondence.

To save time for the contributors, Joseph Houston, ORINS, photographed hundreds of slides. Louise Markel, Marion Garber, Martha Fletcher, and W. F. Harrison of the ORINS library checked all the references and answered question after question. Ruth Black, X-ray technician at the Medical Division, spent hours with the isodose plotter helping in Dr. Darling's work for Appendix C.

The Editors

LIST OF PARTICIPANTS

Balofsky, Samuel L., M. D. (deceased) 1909-1956

Professor of Radiology (Radiotherapy)
Wayne State University College of Medicine
Detroit, Mich.

Barnhard, Howard J., M.D.

Assistant Professor of Radiology
University of Arkansas Medical Center
Little Rock, Ark.

Beauchamp, Edward E., B.S.

Superintendent, Radioisotope Production Department
Isotopes Division
Oak Ridge National Laboratory
P.O. Box X
Oak Ridge, Tenn.

Benner, Sven, Ph. D.

Senior Lecturer in Medical Radiophysics
Radiophysics Institute
University of Gothenburg
Sahlgrenska Sjukhuset, Gothenburg C, Sweden

Berman, Harry L., M.D.; Col., M.C.

Chief, Radiation Therapy Section
Walter Reed Army Hospital
Officers' Service Center
P.O. Box 30
Washington 12, D. C.

Braestrup, Carl B., P.E.

Director, Physics Service
Francis Delafield Hospital
99 Fort Washington Ave.
New York 32, N. Y.

Brucer, Marshall, M.D.

Chairman, Medical Division
Oak Ridge Institute of Nuclear Studies
P.O. Box 117
Oak Ridge, Tenn.

Carpender, J. W. J., M.D.

Professor of Radiology
The University of Chicago
950 East 59th St.
Chicago 37, Ill.

Carroll, David S., M.D.

Professor of Radiology
University of Tennessee College of Medicine
860 Madison Ave.
Memphis, Tenn.

Chalmers, T. A., Ph. D.

Principal Physicist, Radium Institute Liverpool
Lecturer in Physics Applied to Radiology in the
University of Liverpool
Radium Institute
Liverpool, England

Clark, Stanley H., B.S.

Radiologic Physicist
Martin Company, Nuclear Division
Baltimore 3, Md.
(Formerly: Department of Radiation Therapy, Cedars
of Lebanon Hospital, Los Angeles, Calif.)

Collins, Vincent P., M.D.

Professor of Radiology
Baylor University College of Medicine
1200 M.D. Anderson Blvd.
Houston 25, Tex.

Comas, F., M.D.

Radiotherapist
Oak Ridge Institute of Nuclear Studies
P.O. Box 117
Oak Ridge, Tenn.

Cooley, Robert N., M.D.

Professor and Chairman, Department of Radiology
University of Texas Medical Branch
Galveston, Tex.

LIST OF PARTICIPANTS

Cooper, George, Jr., M.D.

Professor of Radiology
University of Virginia
University P.O. Box 3413
Charlottesville, Va.

Eberhard, Theodore P., M.D.

Radiologist
St. Joseph Mercy Hospital
Ann Arbor, Mich.

Ellis, Frank, M.D., M.Sc., F.F.R., D.M.R.

Director, Department of Radiotherapy
Oxford United Hospitals
Lecturer in Radiotherapy, Radiotherapy Department
Churchill Hospital
Oxford, England

Farmer, Frank T., Ph.D.

Chief Physicist
Royal Victoria Infirmary
Newcastle on Tyne, England

Ferlazzo, G., B.S.

Assistant Professor of Radiology (Physics)
State University of New York
Upstate Medical Center
736 Irving Ave.
Syracuse 10, N. Y.

Freid, Jacob R., M.D.

Chief of the Radiotherapy Department
Montefiore Hospital
1049 Park Ave.
New York 28, N. Y.

Friedman, Milton, M.D.

Professor of Clinical Radiology
New York University College of Medicine
Director of Radiation Therapy
Hospital for Joint Diseases
1016 Fifth Ave.
New York 28, N. Y.

Gillette, J. H., B.S.

Superintendent, Isotopes Sales Department
Isotopes Division
Oak Ridge National Laboratory
P.O. Box X
Oak Ridge, Tenn.

Green, D. T., B.Sc.

Nuclear Products Engineer
Picker X-Ray Corporation, Waite Manufacturing
Division, Inc.
17325 Euclid Ave.
Cleveland 12, Ohio

Griffith, Charles R., M.S.

Radiological Physicist
X-ray Division, Westinghouse Electric Corporation
2519 Wilkens Ave.
Baltimore 3, Md.

Guttman, Ruth J., M.D.

Associate Professor of Radiology, Columbia University
Radiotherapist, Francis Delafield Hospital
99 Fort Washington Ave.
New York 32, N. Y.

Hansen, William L., E.E.

Assistant Director of Sales
Keleket X-Ray Corporation
130 High St.
Boston 10, Mass.

Hayes, Raymond L., Ph. D.

Senior Scientist, Medical Division
Oak Ridge Institute of Nuclear Studies
P.O. Box 117
Oak Ridge, Tenn.

Heacock, Charles H., M.D.

Professor of Radiology
University of Tennessee College of Medicine
955 Madison Ave.
Memphis 4, Tenn.

Hetherington, C. H., B.Sc., M.Sc.; Honours Physicist

Works Manager, Commercial Products Division
Atomic Energy of Canada, Limited
P.O. Box 93
Ottawa, Ontario, Canada

Horowitz, Norman H., M.S.

Physicist
Wayne University College of Medicine
Detroit, Mich.

Hudson, Granville W., M.D.

Associate Professor of Radiology
Vanderbilt University School of Medicine
Vanderbilt University Hospital
Nashville 5, Tenn.

Hummon, Irvin F., M.D.

Director, Department of Radiology
Cook County Hospital
1835 West Harrison St.
Chicago 12, Ill.

Hunt, Howard B., M.D.

Chairman and Professor, Department of Radiology
University of Nebraska College of Medicine
Omaha 5, Nebr.

Isherwood, John A., M.D.

Professor of Radiology, Baylor University Graduate
School
Chief, Radiological Service, Brooke Army Hospital
Brooke Army Medical Center
Fort Sam Houston, Tex.

Jacobs, Melville L., M.D.

Chairman, Department of Radiology
City of Hope Medical Center
1500 East Duarte Rd.
Duarte, Calif.

LIST OF PARTICIPANTS

- Jaffe, Henry L., M.D.**
 Clinical Professor of Radiology (Therapeutic)
 University of Southern California School of Medicine
 Director, Radiation Therapy Department
 Cedars of Lebanon Hospital
 4833 Fountain Ave.
 Los Angeles 29, Calif.
- Kakehi, Hirotake, M.D.**
 Professor of Radiology, Department of Radiology
 Chiba University Hospital
 Chiba, Japan
- Kelly, James F., Jr., M.D.**
 Department of Radiology
 Creighton University
 Omaha, Nebr.
- Kerman, Herbert D., M.D.**
 Radiologist
 Halifax District Hospital
 Daytona Beach, Fla.
- Lalanne, Claude M., M.D.**
 Assistant Radiotherapist
 Institut Gustave Roussy
 16 bis, Avenue Paul-Vaillant-Couturier
 Villejuif (Seine), France
- Loevinger, Robert, Ph.D.**
 Research Associate, Stanford University
 W. W. Hanson Laboratories
 Stanford, Calif.
 (Formerly: The Andre Meyer Department of Physics,
 The Mt. Sinai Hospital, New York, N. Y.)
- Lofstrom, James E., M.D.**
 Chairman and Professor, Department of Radiology
 Wayne State University College of Medicine
 Detroit Memorial Hospital
 1420 St. Antoine St.
 Detroit 26, Mich.
- Martin, Doreen, M.D.**
 Consultant
 Women's Hospital
 Liverpool, England
- Mason, James R., B.E.**
 Project Engineer, Teletherapy
 W. F. and John Barnes Company
 301 South Water St.
 Rockford, Ill.
 (Present address: Division of Licensing and Regulation,
 U. S. Atomic Energy Commission, Washington, D. C.)
- Meschan, I., M.D.**
 Professor and Director, Department of Radiology
 North Carolina Baptist Hospital and the Bowman Gray
 School of Medicine of Wake Forest College
 Winston-Salem 7, N. C.
- Mewissen, D. J., M.D.**
 Visiting Scientist, Oak Ridge Institute of Nuclear Studies,
 Medical Division, 1956
 School of Medicine, University of Liège
 Liège, Belgium
- Mooney, Richard T., M.S.**
 Senior Physicist
 Francis Delafield Hospital
 99 Fort Washington Ave.
 New York 32, N. Y.
- Nurnberger, Carl E., Ph.D.**
 Associate Professor of Radiology
 University of Tennessee College of Medicine
 Department of Radiology
 Baptist Memorial Hospital
 Memphis, Tenn.
- O' Foghludha, Fearghus, Ph.D.**
 Visiting Scientist, Oak Ridge Institute of Nuclear Studies,
 Medical Division, 1956
 St. Luke's Hospital
 Dublin, Ireland
- Oosterkamp, Wybe J., Ph.D.**
 Philips Research Laboratories
 Eindhoven, Netherlands
- Quick, Douglas, M.B. (Toronto)**
 Consulting Surgeon:
 Roosevelt Hospital, Janeway Clinic,
 New York City
 Midtown Hospital, New York City
 Midtown Hospital, Morristown, N. J.
 St. Luke's Hospital, Newburgh, N. Y.
 Attending Surgeon:
 Doctors Hospital, New York City
 Mailing Address:
 350 Park Ave.
 New York 22, N. Y.
 (Formerly: Attending Surgeon to the Roosevelt
 Hospital and Director of the Janeway Clinic of the
 Roosevelt Hospital.)
- Quick, Raymond S., B.Sc.**
 Physicist in Chief, Department of Radiology
 Strong Memorial Hospital
 Rochester 20, N. Y.
- Redd, Bryan L., Jr., M.D.**
 Associate in Radiology
 Emory University School of Medicine
 Box 459, Emory University, Ga.
- Reeves, Robert J., M.D.**
 Professor of Radiology and Chairman of Department
 Duke University Medical Center
 Durham, N. C.
- Ridings, G. Ray, M.D.**
 Professor of Radiology, University of Oklahoma
 Medical School
 University Hospital
 800 Northeast 13th St.
 Oklahoma City 4, Okla.
 (Formerly: Associate Professor, University of
 Mississippi Medical School, University Hospital,
 Jackson, Miss.)
- Riemenschneider, Paul A., M.D.**
 Professor of Radiology
 State University of New York
 Upstate Medical Center
 736 Irving Ave., Syracuse 10, N. Y.

LIST OF PARTICIPANTS

- Roberts, J. Eric, D.Sc.**
 Joel Professor of Physics Applied to Medicine
 University of London
 Bernato Joel Laboratories
 The Middlesex Hoospital
 London W.1, England
- Ross, D. A., M.D., Ph. D.**
 Research Scientiat, Medical Division
 Oak Ridge Institute of Nuclear Studies
 P. O. Box 117, Oak Ridge, Tenn.
- Rubinfeld, Sidney, M.D.**
 Profeseor, Clinical Radiology,
 New York University College of Medicine
 New York University—Bellevue Medical Center
 550 Firat Ave., New York, N. Y.
- Savage, Bernard M., M.D.**
 Instructor in Radiology
 Medical College of Virginia
 Richmond, Va.
- Scott, Wendell G., M.D.**
 Professor of Clinical Radiology
 Chairman, Committee on Radiology, National Research
 Council
 Washington University School of Medicine
 100 North Euclid Ave., St. Louis 8, Mo.
- Sennott, Waldron M., M.D.**
 Chief, Radiology Section
 United States Public Health Service Hospital
 Staten Island 4, New York, N. Y.
- Simon, Norman, M.D.**
 Asaistant Attendant Radiotherapist
 The Mt. Sinai Hospital
 945 Fifth Ave., New York 21, N. Y.
- Smedal, Magnus I., M.D.**
 Chief, X-ray Department, Lahey Clinic
 Chief, X-ray Department, New England Baptist Hospital
 Reaearch Associate, Masaachusetts Institute of
 Technology
 605 Commonwealth Ave.
 Boston 15, Mass.
- Smithers, D. W., M.D., F.R.C.P., F.F.R.**
 Professor of Radiotherapy in the University of London at
 The Royal Marsden Hospital and the Institute of Cancer
 Reaearch
 Royal Cancer Hospital
 The Royal Marsden Hospital
 Fulham Rd.
 London S.W.3, England
- Stein, Stephen**
 Nuclear Engineering, Ltd.
 Greenwich Metal Works
 London S.E.7, England
- Steuer, Malcolm F., M.S.**
 Physicist
 University of Virginia Hospital
 Charlottesville, Va.
- Stober, Eugene**
 Manager, Medical Products
 X-ray Division, Westinghouse Electric Corporation
 2519 Wilkens Ave.
 Baltimore 3, Md.
 (Present Address: R. P. Kincheloe Company,
 2929 Elm St., Dallaa, Tex.)
- Ter-Pogossian, Michel M., Ph. D.**
 Associate Professor
 Washington University
 St. Louis, Mo.
- Tice, Galen M., M.D.**
 Professor of Radiology, Head of Department
 University of Kansas School of Medicine
 39th and Rainbow
 Kanaas City 12, Kans.
- Tubiana, Maurice, M.D.**
 Profesaor Agrégé, Chef du Service des Isotopes
 et des Radiations de Haute Energie
 Institut Gustave Roussy
 Villejuif (Seine), France
- Urquhart, Donald W., M.B.Ch.B., D.D.R., D.T.R.**
 Radiotherapist
 175 Grey St.
 Palmerston North, New Zealand
- Vahjen, H. A.**
 Assiatant Technical Director
 Picker X-Ray Corporation
 25 South Broadway
 White Plains, N. Y.
- Wang, Kuang-chu, M.D.**
 Radiologist, Department of Radiology
 National Taiwan Univeralty Hospital
 Taipei, Taiwan (Formosa)
- Weens, H. S., M.D.**
 Professor of Radiology
 Emory University School of Medicine
 69 Butler St.
 Atlanta 3, Ga.

SUMMARY OF THE SYMPOSIUM

Marshall Brucer and Milton Friedman

It is difficult to summarize the symposium because the symposium was in itself a summary. It was a summary of more than a half century of radiation therapy. Perhaps it would be better to say that it was a summary of more than a half century of attempts at radiation therapy. Most of the people participating in the symposium were born when radiation was very young. They grew up and were educated while radiation was growing up and becoming a science that one could get educated to. Some people may say that the science of radiation matured at about the same time most of the participants in the symposium matured as radiation therapists. Certainly World War II can be used as a historical marker to delineate a sudden change from low voltage and radium to a radiation wonder world of supervoltage machines and a host of radioisotopes. Perhaps the easiest summary of the symposium would be to say that the science of radiology has matured at a greater rate than the art of radiotherapy.

The spirit of the symposium could be expressed in the simple quotation, "Radiation is a two-edged sword." But this phrase was not the result of the symposium; it is the title of an editorial that appeared in the *Archives of the Roentgen Ray* before radiation was 10 years old.

In a sense the symposium was celebrating an anniversary, or rather many anniversaries. The symposium was the 60th anniversary of the discovery of radiation. It was the 50th anniversary of the invention of the roentgen. It was the 40th anniversary of the first war in which the peaceful atom played a part. It was the 30th anniversary of the acceptance of the roentgen. It was the 20th anniversary of supervoltage radiation; but, most important, it was the 10th anniversary of the release of atomic energy from military domination. In the summer of 1946, the first shipment of a few microcuries of C^{14} was made from Oak Ridge to a hospital. In the summer of 1956, almost 100 physicians and physicists met in Oak Ridge to discuss their inadequacies in using kilocuries.

As should have been expected in the rebirth of an old science, radiation therapy during these 10 years had entered a second childhood and was interested in toys. Apparatus, gadgets, and sources occupied much of the conversation. At first glance it seems remarkable that in 10 short years so many different kinds of machines and so many different sources could be assembled for use in radiotherapy. At second glance this is not remarkable. The ideas and the machines had all been invented in the dreams of radiotherapists from 50 years in the past. A constant thread of desire that runs through the history of radiation therapy is for higher energies and even higher energies. The definition of the word "supervoltage" was once 250 kev, then it was 400, then 800, then 1000 kev. After World War II, concurrent with the introduction of isotopes, the energy of any source of radiation was limited only by the pocketbook. The status of the megavoltage machine in 10 short years has changed from one of a research instrument proudly installed in a few fortunate hospitals to one in which Co^{60} radiation has already been called "orthovoltage therapy." But the problems of making and installing machines, the problems of protecting oneself from a source of radiation that could be seriously harmful, and the problems of making and distributing the sources are not yet completely solved.

Much of the symposium time was spent in the discussion of dosimetry, much more than would appear from a glance at the table of contents. Since the very beginning of radiation therapy, it has been recognized that physical dosimetry and biological dose are not comparable, but they must be made compatible. One of the recurring themes throughout the symposium was that the formalized step in the right direction has at last been made. The roentgen has been put in its place. It is a unit of exposure, not a unit of dose. Its importance in the science of radiation is not questioned. The roentgen is the unit of radiation. Feelings concerning the rad are not so easily summarized. The amount of energy that is administered to a piece of tissue to make it change its metabolism is, in the last analysis, a unit, but it is not necessarily the only unit since the tissue may affect the rad just as the rad affects the tissue. Therefore there is left a third unit not yet described and hence called the "riddle." The riddle of clinical radiation dosage is exemplified by the following list of sample doses encountered in clinical practice when newer irradiation techniques, radioisotopes, and rotation are used:

1. 6000 rads: a tumor lethal dose with 250-kv X rays used for many squamous-cell cancers.
2. 7500 rads: a common tumor dose for squamous-cell carcinoma when supervoltage X rays are used.
3. 8500 to 10,000 rads: common tumor doses when rotation is used with supervoltage X rays.
4. 15,000 to 20,000 rads: common tissue doses to the cervix from a radium treatment for carcinoma of the cervix.
5. 12,000 to 24,000 roentgens: exposure doses through a grid, used in radical irradiation of some advanced cancers.
6. 20,000 to 30,000 rads: maximum tumor doses close to a radium needle in an interstitial implant.
7. 15,000 to 50,000 rads: for a 12- to 2-cm-diameter mass, respectively. These are the average tumor doses used with permanent Ir¹⁹² implants.
8. 30,000 to 50,000 rads: calculated tissue doses for ablating a normal thyroid gland with I¹³¹.

The implication of these figures is modified by the over-all time factor, the geometry of the irradiated volume, and the geographic dispersion of internal radioactive sources. Nevertheless, the tolerance dose of normal tissues from a well-studied radiation source, such as 200-kv X rays, falls within the range of 4000 to 8000 rads. On the other hand, doses from other types of radiation sources are alleged to be as high as 50,000 rads. It is evident that in clinical practice radiation dose is still a riddle.

The preoccupation with dosimetry during the seminar was in part a confession of inadequacy. There was no clinical substantiation of the value of supervoltage irradiation in increasing the cure rate of cancer. In hundreds of articles written during the past decade, the word "supervoltage" uniformly evokes certain clichés: skin sparing, greater depth dose, better palliation, bone sparing effects. To some these alleged advantages warrant the purchase price. To those who believe that the high cost of supervoltage irradiation is warranted only by an increased cure rate, it is evident that a complete answer will not be available for many years. In a few tumors, such as cancer of the testis, osteogenic sarcoma, and possibly some advanced cancers of the cervix, supervoltage irradiation has demonstrably increased the cure rate. In others, such as cancer of the lung, esophagus, anterior two-thirds of the tongue, and the parotid, it has been disappointing. The reason for the disappointment with supervoltage irradiation lies in the 60-30-10 law. This restatement of a well-known principle is as follows: The value of the factors that influence irradiation cures are 60 per cent for the nature and extent of the tumor, 30 per cent for the skill and experience of the therapist, and 10 per cent for the modality used. Thus supervoltage may potentially increase the cure rate for cancer only about 10 per cent.

This law was not hypothetically contrived but arose from a study of results. Since it is current lore that 6000 rads cures many cancers and since it is, with supervoltage, easy to administer 6000 rads to almost any part of the body, an early increase in the cure rate was expected. This did not materialize. With increasing experience it became evident that factors other than the modality were far more important in eradicating a tumor. It was also evident that factors other than cure have an importance in assessing the modality. *A reasonable summary of the symposium is that supervoltage is an improved tool for radiotherapy.*

CONTENTS

Preface	iii
List of Participants	v
Summary of the Symposium	ix

PART 1 DOSAGE CONSIDERATIONS

Section A Dosimetry of Radiation

Carl B. Braestrup (presiding)

Chapter 1 Meaning of the Basic Units of Dosage to Tissue	3
Robert Loevinger	
Chapter 2 Distribution of Dose from Beams of Radiation	11
T. A. Chalmers	
Chapter 3 Methods of Calculation and Planning of Tissue Dosage	16
Sven Benner	
Chapter 4 Discussion	23
Opened by J. Eric Roberts	
Maurice Tubiana	

Section B Dosimetry of Moving Fields

Howard B. Hunt (presiding)

Chapter 5 Limiting Factors of Moving-field Dosimetry	29
J. Eric Roberts	
Chapter 6 Classical Isodose Curves for Moving Fields	39
Fearghus O'Foghludha	
Chapter 7 Experiences with Clinical Moving-field Dosimetry	44
Stanley H. Clark	
Chapter 8 Chemical Measurements of Integral Dose	61
Raymond L. Hayes	
Chapter 9 Discussion	69
Opened by Raymond S. Quick	
Carl E. Nurnberger	

PART 2 APPARATUS AND SOURCES**Section C Machine Design**

Marshall Brucer (presiding)

Chapter 10 Picker X-Ray Corporation Co ⁶⁰ Teletherapy Machines	77
D. T. Green	
Chapter 11 Problems Related to the Use of X-ray Equipment	84
Eugene Stober	
Chapter 12 Keleket-Barnes Cobalt Apparatus	86
William L. Hansen	
Chapter 13 Atomic Energy of Canada, Limited, Co ⁶⁰ Teletherapy Units	95
C. H. Hetherington	
Chapter 14 Nuclear Engineering, Limited, Gamma-ray Teletherapy Units	97
Stephen Stein	
Chapter 15 Teletherapy in Japan	108
Hirotake Kakehi	
Chapter 16 City of Hope Teletherapy Unit	114
Melville L. Jacobs	
Chapter 17 Emory University Teletherapy Unit	116
H. S. Weens	
Chapter 18 Discussion	122
Opened by Raymond S. Quick	
Carl B. Braestrup	
Theodore P. Eberhard	

Section D Installation Problems

Galen M. Tice (presiding)

Chapter 19 Problems of Supervoltage Installation and Protection	127
Carl B. Braestrup	
Chapter 20 An Exhibition of the Installation of Co ⁶⁰ Teletherapy Machines	132
Marshall Brucer	
Chapter 21 Discussion	140
Opened by Paul A. Riemenschneider	
G. Ferlazzo	

Section E Sources of Energy

Galen M. Tice (presiding)

Chapter 22 Source Production by Atomic Energy of Canada, Limited	151
C. H. Hetherington	
Chapter 23 Source Production by U. S. Atomic Energy Commission, Oak Ridge	153
J. H. Gillette	
Chapter 24 World Production Estimates	155
Marshall Brucer	
Chapter 25 Discussion	162
Opened by James F. Kelly, Jr.	
John A. Isherwood	

PART 3 PRINCIPLES OF CLINICAL SUPERVOLTAGE IRRADIATION**Section F Moving-field Therapy**

Herbert D. Kerman (presiding)

Chapter 26	Indications for Moving-field Therapy	171
	J. W. J. Carpender	
Chapter 27	Contraindications to Moving-field Therapy	180
	Frank Ellis	
Chapter 28	Clinical Experiences with a Moving-field Machine	189
	Ruth J. Guttman	
Chapter 29	Clinical Experiences with a Rotating-chair Machine	196
	Henry L. Jaffe	
Chapter 30	Discussion	205
	Opened by Jacob R. Freid	
	Galen M. Tice	

Section G Clinical Radiobiology

Robert J. Reeves (presiding)

Chapter 31	Normal Tissue Tolerance	217
	Milton Friedman	
Chapter 32	Radiation Pneumonitis	239
	Harry L. Berman	
Chapter 33	Discussion	253
	Opened by G. Ray Ridings	
Chapter 34	Irradiation of Metastases	255
	Douglas Quick	
Chapter 35	Discussion	267
	Opened by Howard B. Hunt	
Chapter 36	Assessment of the Results of Therapy	269
	Vincent P. Collins	
Chapter 37	Discussion	274
	Opened by George Cooper, Jr.	

Section H Indications and Contraindications

Milton Friedman (presiding)

Chapter 38	Short Source-to-Skin Distance Co ⁶⁰ Teletherapy	277
	Norman Simon	
Chapter 39	Two Million Volt Therapy	283
	Magnus I. Smedal	
Chapter 40	Betatron Therapy	300
	Maurice Tubiana	
Chapter 41	Discussion	312
	Opened by James F. Kelly, Jr.	
	Robert N. Cooley	

Section I Special Techniques for Special Tumors

John A. Isherwood and Vincent P. Collins (presiding)

Chapter 42	The Esophagus	319
	Irvin F. Hummon	
Chapter 43	The Breast	327
	Robert N. Cooley	
Chapter 44	The Cervix	334
	I. Meschan	
Chapter 45	The Brain	350
	Jacob R. Freid	
Chapter 46	The Head and Neck	356
	Melville L. Jacobs	
Chapter 47	The Lung	359
	James E. Lofstrom	

PART 4 DISCUSSION OF CASE PROBLEMS

Section J Clinic on Stationary Fields

David S. Carroll (presiding)

Chapter 48	Carcinoma of the Tongue, Case Report	367
	David S. Carroll	
Chapter 49	Treatment of Carcinoma of the Cervix with Co ⁶⁰ Teletherapy	369
	Irvin F. Hummon	
Chapter 50	Carcinoma of the Lung, Illustrating the Avoidance of the Spinal Cord with Co ⁶⁰ Teletherapy	372
	Norman Simon	
Chapter 51	Carcinoma of the Floor of the Mouth, Case Report	377
	Bryan L. Redd, Jr.	
Chapter 52	Discussion	380

Section K Clinic on Moving Fields

J. W. J. Carpender (presiding)

Chapter 53	Reticulum-cell Sarcoma of Nasal Sinus	387
	J. W. J. Carpender	
Chapter 54	Rhabdomyosarcoma of the Neck; Radiation Myelitis	389
	Magnus I. Smedal	
Chapter 55	Metastatic Carcinoma of the Lung	391
	Ruth J. Guttmann	
Chapter 56	Discussion	395

Section L Clinic on Unusual Cases

James E. Lofstrom (presiding)

Chapter 57	Carcinoma of the Esophagus	399
	Sidney Rubinfeld	
Chapter 58	Lymphangiosarcoma in a Lymphedematous Arm	404
	Granville W. Hudson	

CONTENTS

Chapter 59 Carcinoma of the Urethra 410
Howard J. Barnhard

Chapter 60 Advanced Gastrointestinal Carcinoma 415
Samuel L. Balofsky

Chapter 61 Discussion 418

PART 5 SPECIAL TALKS

Section M General Considerations

Howard B. Hunt and Carl B. Braestrup (presiding)

Chapter 62 Legislative and Professional Controls of the Use of
Radiation 425
Wendell G. Scott

Chapter 63 Discussion 429

Chapter 64 What Needs To Be Done in Radiotherapeutic Research 432
D. W. Smithers

Chapter 65 Discussion 445

Section N Brachytherapy Devices

Marshall Brucer (presiding)

Chapter 66 A Survey of Brachytherapy 449
Marshall Brucer

Chapter 67 Szilard-Chalmers Reaction for the Manufacture of
Brachytherapy Devices 457
T. A. Chalmers

Chapter 68 Use of Tantalum Wires 459
Frank Ellis

Chapter 69 A Bead-handling Device 465
Stanley H. Clark

APPENDIXES

Isodose Curves

Appendix A Cobalt Isodose Patterns for Moving Beams 471
Carl B. Braestrup and Richard T. Mooney

Appendix B Supervoltage Rotation Dosage Patterns for Head and
Neck Cancer 478
Milton Friedman and William H. Ellett

Appendix C The Practicality of Cesium as a Teletherapy Source 485
Donald B. Darling

Bibliography 491

PART

DOSAGE CONSIDERATIONS



Section

A

Dosimetry of Radiation

Carl B. Braestrup
(presiding)

Meaning of the Basic Units of Dosage to Tissue

CHAPTER 1

Robert Loevinger

Andre Meyer Department of Physics*
Mt. Sinai Hospital
New York, New York

Introduction

This talk is addressed to the conscientious radio-therapist and radiobiologist who wishes to be reasonably accurate in his dosimetry but who also may be somewhat puzzled by the parade of units which has passed before him in recent years. The units-of-dose situation appears to have stabilized at last, and this talk attempts to describe what are now considered to be the most meaningful units, not being concerned with the problems of the standardizing laboratory. On the contrary, it is assumed that each of us has access to a competent standardizing laboratory, such as the National Bureau of Standards (NBS) here in the United States.

For the purpose of this talk supervoltage radiation is taken to be electromagnetic radiation of sufficiently high photon energy that photoelectric absorption is negligible in biological materials, i.e., differential bone absorption has disappeared. The general situation is illustrated in Fig. 1. Photons of energy less than about 0.3 Mev show a high dose to bone relative to the dose to soft tissue owing to photoelectric absorption in the high-Z material of the bony matrix. It is convenient to take as the lower edge of the supervoltage region the energy at which this photoelectric absorption becomes negligible, or about 0.3 Mev photon energy. From 0.3 to 3 Mev there is a constant ratio between the absorbed dose to bone and to soft tissue which arises from the fact that only the Compton effect is important in X-ray absorption in this energy region. The subsequent discussion will show that this is the energy region where the roentgen is a useful unit for measuring supervoltage radiation dose. The rising bone absorption for photon energies above 3 Mev is due to the increasing importance of pair

production. It happens that this is just the supervoltage energy region where the roentgen fails as a unit of dose and it becomes necessary to use the rad.

At present there is only one unit of absorbed dose to tissue. That unit is the rad, which represents 100 ergs/g of absorbed energy. For reasons of convenience the roentgen is frequently used to specify tissue dose. This is acceptable when, but only when, there is a reasonably accurate method of converting from roentgens to rads.

Thus we first turn our attention to the roentgen to see the circumstances under which it is to be considered a respectable unit of dose.

The Roentgen

The roentgen is defined in terms of electrostatic units per cubic centimeter of air at standard temperature and pressure (S.T.P.), provided all the ionization from the secondary electrons is included in the measurements.² The consequence of such a definition can be seen with the help of Fig. 2, which illustrates a volume of air exposed to a beam of X rays, indicated by the arrows going from left to right. The ionization in the air is measured in the collecting volume indicated. The secondary electrons will be projected forward into some volume, which is designated "distal volume" in the illustration. Thus the ionization in the collecting volume due to secondaries arising there will fall short of the total ionization required to give true roentgens by the amount of ionization occurring in the distal volume due to electrons originating in the collecting volume. Under some circumstances, however, there will be a mirror-image volume, designated "proximal volume" in Fig. 2, from which secondary electrons reach the collecting volume and provide ionization that just compensates for that lost. Under these circumstances of exact electron compensation, ionization measurements in the collecting volume will give correct roentgens.

* Present address: Stanford University, Stanford, Calif.

[Editors' Note: For a review and clarification of this entire subject, see Report of the International Commission on Radiological Units and Measurements (ICRU), 1956; National Bureau of Standards Handbook 62, for sale by the Superintendent of Documents, U. S. Government Printing Office, Washington 25, D. C., April 1957.]

Another way of describing the situation illustrated by Fig. 2 is to say that in practice (though not in definition) the roentgen is an equilibrium unit of ionization. The energy absorbed from the X-ray beam per

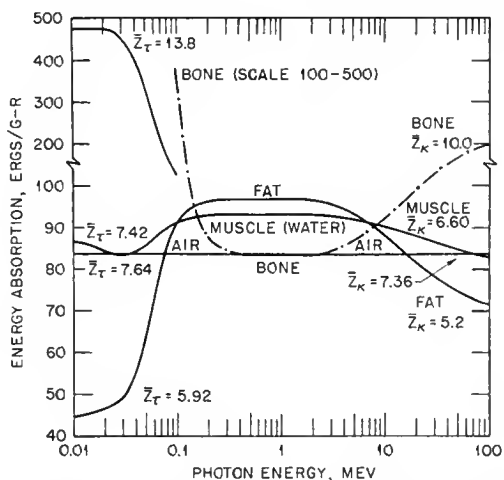

Fig. 1 — Energy absorption in bone, muscle, and fat, relative to energy absorption in air, as a function of photon energy.¹

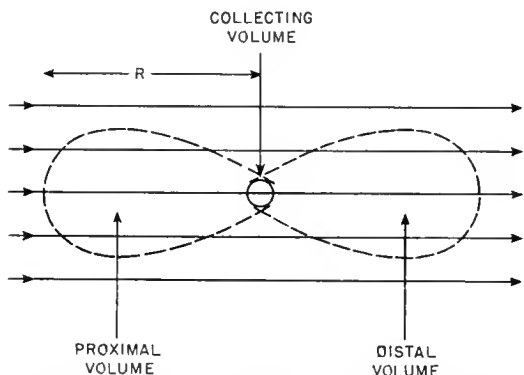

Fig. 2 — Diagrammatic illustration of secondary-electron compensation for measurement in terms of roentgens.

unit volume just equals the energy per unit volume appearing in the form of moving electrons due to the equilibrium that is established between energy projected into the distal volume and energy replaced from the proximal volume.

It seems evident from Fig. 2 that this equilibrium, or electron compensation, can exist only if the X-ray flux is constant in quantity and quality over the distance marked R. If the flux changes appreciably in the distance R, the exact electron compensation is lost, and there exists no simple relation between the energy absorbed from the X-ray beam in the collecting volume and the ionization observed there. Thus R represents the maximum range of the secondary electrons.

The relation between the range of the electrons and the absorption of the X-ray flux is shown in Fig. 3.

The upper part of the figure gives the maximum range of the secondary electrons, R, and the total linear absorption coefficient, μ , for photon energies from 200 kev to 100 Mev. The ordinate scale on the right is in terms of centimeters of air, and that at the left, centimeters of water. Notice that the maximum range of the secondary electrons increases by a factor of almost 10^4 in the illustrated energy interval; whereas the absorption decreases by a factor of 10 only. The lower part of the figure gives $e^{-\mu R}$, which is the fraction of the X-ray flux which is neither absorbed nor scattered in traversing the distance R. Notice that, up to about 1 Mev, $e^{-\mu R}$ is essentially unity. For energies above a few Mev, $e^{-\mu R}$ begins to fall rapidly, reaching about 0.4 at 100 Mev. Herein lies a fundamental difficulty with the use of the roentgen at high photon energies. The absorption of the X-ray flux becomes appreciable in the distance traveled by the secondary electrons, electron compensation is not possible, and the roentgen loses its meaning as a unit of dose.³⁻⁵ The International Commission on Radiological Units (ICRU) has recommended that the roentgen be used up to a photon energy of 3 Mev only,² a recommendation that appears plausible from examination of Fig. 3, in which the curve for R is broken at the highest photon energies to indicate that the concept of maximum range becomes obscured at these energies.

Figure 1 shows that it was just at 3-Mev photon energy that the dose to bone relative to soft tissue began to increase owing to absorption by pair production. This accounts for part, but not all, of the failure of the roentgen as a unit at very high photon ener-

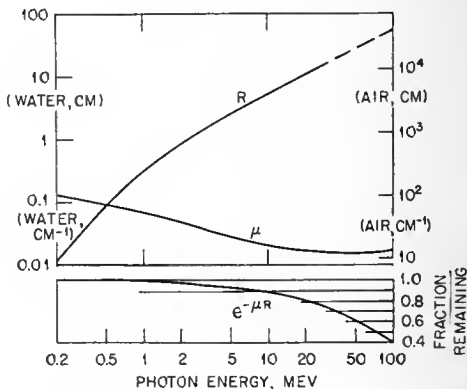

Fig. 3 — Absorption of primary flux in roentgen measurements.

gies. Even if there were no pair production, the absorption coefficient of the radiation would not fall so rapidly as the range of the secondaries increases, and there would be some difficulty in realizing electron compensation for high-energy roentgen measurements.

There are actually many theoretical and practical difficulties in using the roentgen as a unit of dose at high photon energies. From the physics viewpoint, however, this inability to attain electron equilibrium

may be considered the basic difficulty. From the clinical viewpoint there are difficulties of another kind. The maximum range of the secondary electrons, R in Fig. 3, gives the order of magnitude of the thickness of absorbing material required to attain electron equilibrium. When that thickness attains dimensions of clinical significance, the roentgen becomes of limited value, even assuming that it can properly be measured, because it is impossible to use roentgen measurements to obtain information about dose distribution over dimensions smaller than those required to attain electron equilibrium.

Figure 4 illustrates this problem. The lower part of the figure shows diagrammatically how ionization

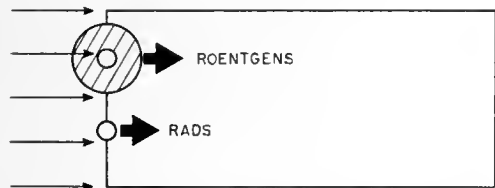
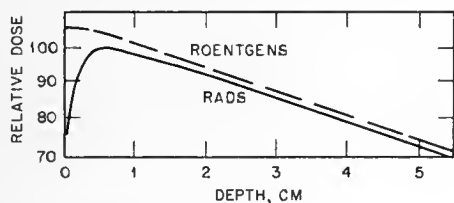

Fig. 4—Hypothetical illustration of the difference between depth-dose measurements in roentgens and in rads for Co^{60} radiation.

measurements would be made in a water phantom to obtain roentgens and rads. Because the roentgen is an equilibrium unit, it would be necessary to use a thick-walled ionization chamber, i.e., all the secondary electrons must arise in the wall of the ion chamber. On the other hand, measurements in rads would be carried out with a thin-walled ion chamber so that most of the secondary electrons would arise in the water phantom. The results of such measurements are shown at the top of the figure, which represents depth-dose measurements from a Co^{60} source. The roentgen measurements give no information about the nonequilibrium depths near the skin. The small percentage of difference between depth dose in roentgens and in rads for depths greater than electron equilibrium represents merely a known conversion constant. If the phantom were heterogeneous to the extent of having a bone in it, roentgen measurements could not be made just behind the bone.

The method of making measurements in roentgens for supervoltage beams is essentially the same as that for ordinary deep-therapy voltages. A reliable commercial thimble chamber is obtained with walls thick enough for use at the highest desired energy. This is calibrated in roentgens for the energy of interest by NBS or other competent standardizing laboratories. It can then be used without special pre-

cautions at the energies for which it has been calibrated. At present the NBS is prepared to calibrate thimble chambers⁶ in roentgens with the gamma rays of Co^{60} . Thimble chambers calibrated in roentgens for a Co^{60} beam could probably be used to measure in roentgens the dose rate of X-ray machines with energies up to 3 Mev.

Table 1—ENERGY ABSORPTION PER ROENTGEN FOR QUANTUM ENERGIES FROM 0.3 TO 3 MEV*

Material	Electron density, electrons/g	Mass density, g/cm ³	Rads per roentgen	Ref.†
Air (S.T.P.)	3.005×10^{23}	0.001293	0.88	7
Bone (dry)	3.00×10^{23}	1.85	0.88	2
Bone (femur)	3.19×10^{23}		0.93	6
Whole mouse	3.31×10^{23}		0.97	7
Water	3.344×10^{23}	1.00	0.98	7
Muscle	3.38×10^{23}	1.00	0.98	2
Muscle (striated)	3.31×10^{23}		0.97	8
Subcutaneous fat	3.48×10^{23}	0.91	1.02	2

* Values are based on $W = 34$ ev/ion pair.⁷

† References give the source of the density values listed.

Although the NBS, as well as the National Physical Laboratory of Britain, will now calibrate thimble chambers for Co^{60} in roentgens, this does not imply that these roentgens are on the same solid basis as are the roentgens based on free-air chambers at the lower quantum energies. There are still some uncertainties, and the possibility exists that the present Co^{60} roentgen might be in error by several per cent. The NBS is now setting up a free-air pressure chamber to make absolute measurements in roentgens for photon energies up to 2 to 3 Mev. Presumably any remaining uncertainties will be resolved when that chamber is completed, which is scheduled for the end⁶ of 1956.

Present usage requires that roentgens be considered an expression of exposure dose, to be distinguished from absorbed dose expressed in rads.⁶

If the exposure dose in roentgens is known, how should the absorbed dose in rads be obtained? The conversion is made by use of the factors given in Table 1. It turns out to be an easy computation for those supervoltage energies for which the roentgen is a valid unit. For photon energies between 0.3 and 3 Mev, only Compton absorption is of importance, and as a result the true mass absorption coefficient is proportional to the number of electrons per gram. Starting with the ionization due to 1 r (1 esu/cm³, by definition) and using the best available estimate of the average energy per ion pair, it is readily computed that the energy absorption per roentgen is about 88 ergs/g in air. From this result and the ratios of the electron densities, there follow the values of the rads per roentgen conversion factor for various substances, as given in Table 1, where it is seen that the best value of the conversion factor from roentgens to rads is unity for soft tissues and photon energies from 0.3 to 3 Mev. For bone the conversion factor is about 12 per cent less than unity.

It should be noted that the conversion factors given in Table 1 are based on an average energy per ion pair of $W = 34$ ev. Although this appears to be the best value at the present time,^{2,7} it is uncertain by at least several per cent.

The present status of the roentgen as a unit of dose can be summarized as follows:

1. For measuring exposure dose rate in air from gamma-ray beams up to Co^{60} energy or X-ray beams up to about 3 Mev, the roentgen is an acceptable unit. It has the advantage that dose rates given in roentgens are free of the uncertainty that still remains in the value of the average energy per ion pair. Still more important is the fact that having a thimble chamber calibrated in roentgens at a standardizing laboratory is a relatively simple, inexpensive, and reliable procedure. In the future there may be many hundreds of Cs^{137} and Co^{60} units used for radiation therapy. It is proper that this simple and reliable method be used for calibrating these sources, i.e., for measuring the exposure dose rate in air at a fixed distance. Such information can be converted to absorbed dose rate in rads per unit time by using Table 1.

2. For making supervoltage depth-dose measurements or for giving supervoltage depth-dose curves, the roentgen is a bad unit. Since dose information is needed for nonequilibrium situations, in such locations as just beneath the skin or just behind bone, it is clear that depth-dose curves must be made in rads.

3. Tissue dose to patients can be given either as exposure dose in roentgens or as absorbed dose in rads. It is common practice in radiotherapy to assume that all patients are perfect and that the perfect patient is made of water. When treatment is made on this assumption, it seems acceptable to express the dose to tissue as exposure dose in roentgens for photon energies up to about 3 Mev. However, the ICRU and many others, including myself, are of the opinion that it is much preferable to give tissue dose in rads. Thus it is concluded here that for this energy region the roentgen is an inferior, but probably acceptable, unit of tissue dose.

The Rad

The rad is defined as 100 ergs/g of absorbed energy. Its virtue lies in the ergs per gram, not in the 100. If someone prefers to use 93, or 83, or 113 ergs/g, it can be ascribed to eccentricity. Ergs per gram, however, is essential in that it offers the best physical quantity for correlation with radiobiological response.

There are many ways of measuring absorbed dose in rads. By far the most common is the ionization chamber, using the Bragg-Gray principle to interpret ionization per unit volume in ergs per gram.⁸ These ion chambers must have thin walls so that the secondary rays will arise mainly in the external absorbing material, usually a plastic or water phantom. They can conveniently be made of arbitrary size and shape, calibrated against a standard of some sort,

and used for routine relative measurements. Equally well, ion chambers can be made to serve as standards, giving results accurate to a few per cent in absolute terms.

Scintillation crystals can also be used for measurement of rads in the supervoltage energy region and under some circumstances are very convenient and sensitive for relative measurements.⁹ However, scintillation crystals cannot be used for absolute measurements.

Under certain special circumstances photographic film can be used conveniently for dose-distribution measurements, ordinarily yielding relative measurements only.¹⁰ The special techniques and care required for photographic dose measurements limit the situations in which they are useful. When applicable, photographic techniques are very convenient, as in studying complicated dose distributions from moving-beam therapy.

Chemical and colorimetric methods can be used for energy-absorption measurements from supervoltage beams.¹¹ The relative insensitivity of these methods and the elaborate specialized laboratory techniques involved have limited their use thus far; development of greater sensitivity and simpler techniques would, of course, change this picture. These methods have the advantage of being a direct measure of absorbed energy and can be used either for routine measurements against some standard or for making absolute measurements. Chemical and colorimetric methods also can be used in any desired volume, an unusual feature, thus furnishing automatically an integral dose over that volume.

Calorimetric methods are probably the only methods unsuitable for routine use under any circumstances. However, direct calorimetric measurement of absorbed energy is a very important method of establishing absolute standards. It has been applied both to total absorption of a beam and to measurement of locally absorbed energy.¹² It has so far served mainly to verify the essential accuracy of the ionization methods. It seems safe to say that calorimetric techniques will be used in only a few research laboratories.

Thus the ionization method still has by far the best combination of convenience, reliability, and sensitivity. It is also the only absolute method readily available to most radiological physics laboratories.¹³

The relation between observed ionization and absorbed dose in rads is shown in Table 2, which presents the results of a theoretical calculation of the number of rads per electrostatic unit per cubic centimeter for various wall materials and photon spectrums based on the Bragg-Gray principle with certain recent modifications.⁷ Because of the method of calculation these numbers apply strictly to a parallel-plate ionization chamber, although the values for plastics and water can probably be used with any Bragg-Gray chamber of these materials. They probably represent the most authoritative conversion factors for Bragg-Gray chambers now available. These figures will be supplemented in the future by a tabulation of the nu-

merical values of the physical parameters entering the Bragg-Gray theory, to be issued by the ICRU.⁶ The ICRU proposes to revise these numbers periodically, and therefore the absolute accuracy of cavity ionization chambers, now of the order of ± 5 per cent, can be expected to improve greatly as time goes on.

Table 2—RADS/(ESU/CM³) FOR VARIOUS WALL MATERIALS AND PHOTON SPECTRUMS*

Photon spectrum	Wall material		
	Lucite and polystyrene	Water	Aluminum
130 to 250 kev (filtered)	1.00	1.02	0.79
1 Mev	1.00	1.02	0.80
Co ⁶⁰ (1.25 Mev)	0.99	1.015	0.81
22.5 Mev	0.94	0.96	0.79

* The factors have been calculated for a plane-parallel ionization chamber with a collecting diameter that is large compared to the air gap, in a beam that is large compared to the collecting diameter, and with an air gap in the range of 0.5 to 1.0 mm at S.T.P.⁷

Two aspects of Table 2 are of particular interest: the factors show only a very small energy dependence for a given wall material, and plastic and water walls differ by only 2 per cent at all energies. This means that ionization measurements made in a water phantom with a small thin-walled plastic ionization chamber can be readily converted into absorbed dose in rads. This applies to a homogeneous or heterogeneous phantom. In other words, Table 2 shows that it is relatively easy to realize the supervoltage rad experimentally.

In addition, Table 2 data show that the absolute value in rads can be obtained from ionization measurements by establishing electrostatic units per cubic centimeter either by direct physical means or indirectly by calibration against a secondary roentgen standard.

The present status of the rad can be summarized as follows: It is the only acceptable unit of absorbed dose and the best unit in which to express tissue dose. It is the only unit in which supervoltage dose distribution can be given for a homogeneous or heterogeneous phantom. It is at present most easily obtained experimentally by ionization techniques, which have an absolute accuracy of about ± 5 per cent.

Interpreting the Rad

Relative Dose in Different Tissues. The dose in bone, muscle, and fat relative to the dose in air over a wide range of photon energies was shown in Fig. 1. When depth-dose curves in rads are used, particularly in the higher energy portion of the supervoltage region, this information relative to air becomes less interesting. The same data are shown in Fig. 5 as the absorbed dose in bone and fat relative to muscle (which is equivalent to water). (The curves in Fig. 5 were computed from data given by Spiers.²) It is interesting to note that there is no important change in

bone dose relative to soft tissue over the entire supervoltage energy region presently available, i.e., from Cs¹³⁷ at 0.66 Mev to a 30-Mev betatron. At very high photon energies, e.g., 50 to 100 Mev, bone absorption may become a problem. At these energies the dose to soft tissue in the cavities of the Haversian system will certainly rise to several times the dose received by soft tissue remote from bone.

Several steps are involved in determining the absorbed energy in tissue in a heterogeneous phantom, i.e., in a patient. The first step is contained in Fig. 5. The next step is to estimate the shadowing effect of tissues other than muscle. Figure 6 illustrates the dose-shadow ratio for bone and fat at the lower supervoltage energies. This ratio gives the dose at a point

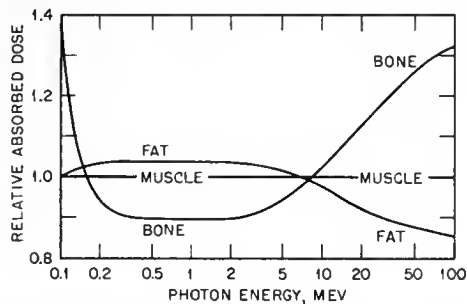

Fig. 5—Absorbed dose in bone and fat, relative to absorbed dose in muscle, as a function of photon energy. Curves computed from data given by Spiers.²

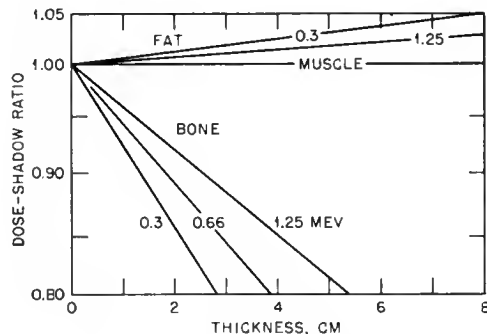

Fig. 6—Dose-shadow ratio for bone and fat at low supervoltage energies.

distal to bone or fat as a fraction of the dose that would exist at that point if the bone or fat were not present. This figure has been computed according to a suggestion of Spiers,¹⁴ with the assumption that the shadowing is an exponential function of the thickness times the difference in the total absorption coefficient. For energies greater than Co⁶⁰ it is probably best to assume that there is no tissue shadowing, i.e., the depth dose need not be modified for a heterogeneous phantom at betatron energies.

Figure 7 shows the application of these notions to a heterogeneous phantom, which is supposed to represent the series of tissues encountered in a lateral pelvic field.¹⁵ This figure shows the relative depth

dose in rads from a Co^{60} beam in a homogeneous water phantom, the depth dose modified for the heterogeneous phantom, and the energy absorbed in the medium. The modification of the depth dose for the bone consists in multiplying the relative depth dose at 9 cm by the shadowing ratio from Fig. 6 to get the

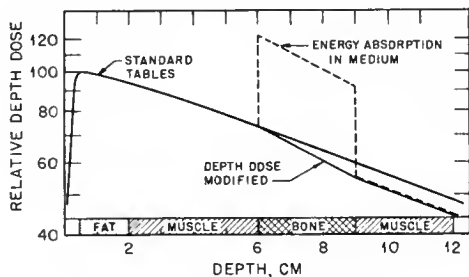

Fig. 7—Relative depth dose in a phantom consisting of layers of skin, fat, muscle, bone, and muscle treated with Co^{60} radiation.¹⁵

new soft-tissue dose at 9 cm depth. The depth-dose curve is then drawn parallel thereafter to its original curve. The modified depth-dose curve is multiplied by the relative absorbed dose from Fig. 5 and then multiplied again by the density (1.85 g/cm^3 for bone) to get the energy absorption in the medium in energy per unit volume. This is presented as the type of analysis that must be made to convert depth-dose curves in rads in a homogeneous phantom into curves giving useful absorbed-dose information in heterogeneous phantoms. [At the time Fig. 6 was made by its original author, the absorbed energy per unit volume was believed to be of some interest. At the present time little interest attaches to it, and as a rule it would not be worth calculating.] Most of the physical information for these calculations is probably not available. When enough biological information is available to make many such curves, depth-dose distributions in rads will become more realistic.

Linear Energy Transfer. The question may be asked whether there are important differences between the radiobiological effect of different supervoltage radiations not evident from depth-dose distributions in rads. The first step in attempting to give an answer is to examine the linear energy transfer (LET) from the secondary electrons set in motion by a supervoltage beam. Figure 8 is a graph of LET to water for a wide range of electron energies. Note that the minimum value of LET occurs at a few million electron volts of energy, where the value is $0.19 \text{ kev}/\mu$. Also shown in Fig. 8 is the approximate spread of electron energies for the secondary electrons of the four photon spectrums indicated. Note that Co^{60} just reaches, whereas the 22-Mev betatron passes, the minimum LET value. Evidently higher energy photon spectrums would show LET values much like those of the 22-Mev betatron. High-energy photons transfer a large fraction of their energy to forward-moving secondary electrons, but low-energy photons transfer a much smaller fraction of their energy to secondary

electrons. The resulting LET distributions in water are shown in Fig. 9. Co^{60} and betatron radiations show a narrow range of LET values, from 0.19 to about $0.25 \text{ kev}/\mu$. Other supervoltage photon spectrums show similar distributions of LET. On the other hand, the 220-kv spectrum shows a broad distribution of LET, from about 0.3 up to at least $10 \text{ kev}/\mu$. All the curves in Fig. 9 are drawn to the same scale and normalized to the same area for purposes of comparison.¹⁵ From these curves it is not surprising that there is a difference between the relative biological effectiveness (RBE) of 220-kv radiation and supervoltage radiation. However, the curves suggest no important difference between the radiobiological effect of Co^{60} and betatron radiation except that which arises from differences in dose distribution as shown by depth-dose curves.

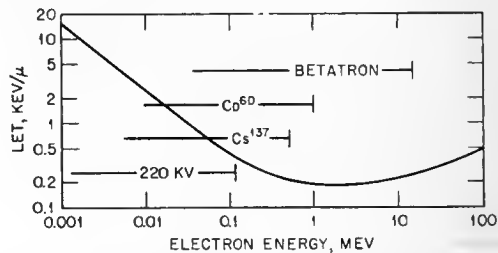

Fig. 8—LET of electrons in water as a function of electron energy and the approximate spreads of the energies of the secondary electrons arising in water from the photon spectrums indicated.

Basic Processes. Stating the absorbed dose in rads at a particular point in tissue is only the beginning of a complicated story. The energy absorbed from a beam of radiation is degraded by a series of atomic processes to individual activations of the order of 10 ev . These activations (ionizations and excitations) start a chain of atomic and molecular processes that disrupt chemical bonds, some of which are in vital molecules. Certainly the real meaning of the rad lies in these basic processes.

The energy absorbed from supervoltage radiations is imparted to secondary electrons, which, in turn, lose energy mainly by a single process, collisions with the outermost atomic electrons. Since the secondary radiations lose energy in a narrow range of LET, it is reasonable to expect that the subsequent basic processes are similar for all supervoltage photon spectrums and for supervoltage electron beams. Thus it can be expected that one supervoltage rad will have a similar radiobiological effect to any other supervoltage rad from less than 1 Mev to 100 Mev .

The fact that a variation in RBE is not expected in the supervoltage energy region does not exclude the possibility that it may exist. There is another aspect of supervoltage accelerators which may be pertinent here. The accelerators deliver pulsed radiation, which may be radiobiologically different from the steady radiation of a supervoltage gamma-ray beam. It is even possible that the RBE of pulsed beams may be a function of the pulse frequency.

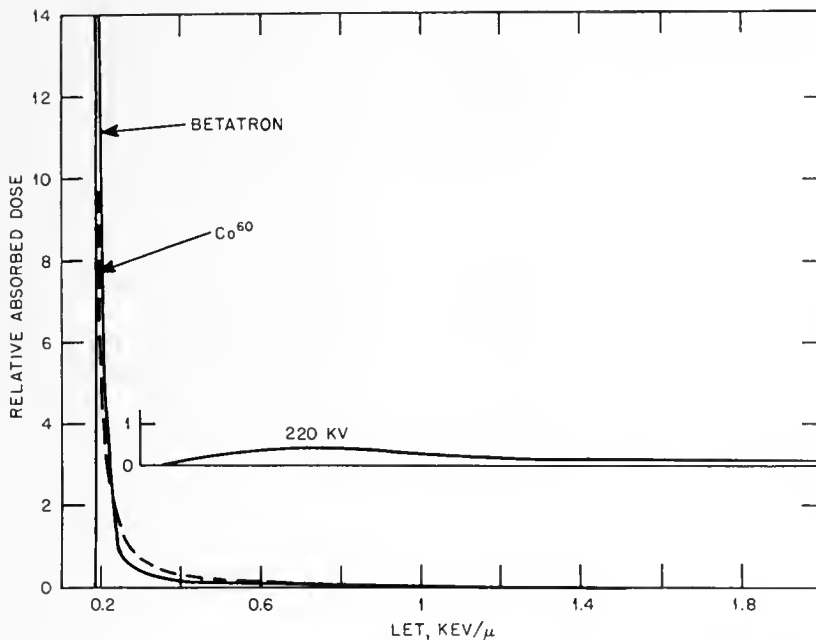

Fig. 9—Distribution of LET for the photon spectrums indicated for secondary electrons in water.

Recommendations

Although much of the confusion in the field of clinical dosimetry has been cleared away, the situation cannot yet be called ideal. In particular, the word roentgen is used in a number of ways, very frequently enclosed in quotation marks to indicate that it does not really mean what it says. The following recommendations are offered with the hope that they will not enhance any present confusion.

For the instrument makers there are two recommendations: (1) Provide a good commercial chamber suitable for measuring the rad at photon energies above 3 Mev. This could be a small thin-walled plastic chamber, the volume of which has been accurately determined by roentgen calibration at Co^{60} energy. Determining the volume of a small ion chamber is difficult for those who do it only once but should be easy to do routinely. (2) Remove the label "roentgen" from the scales of all instruments designed for dose calibration at the therapy level.¹⁶ Use a simple numerical scale. On the outside of the instrument there should be a provision for displaying the scale calibration factor for each beam for which the instrument has been calibrated. This practice would end the erroneous use of the word roentgen as meaning "scale reading" and would probably contribute to the introduction of rational units of tissue dose.

For the radiotherapists there are three recommendations: (1) Start thinking in terms of rads. This means to have a clear conception of the nonequilibrium situations and the differences in density and composition of various tissues. (2) Start using the rad. This means to express the tissue dose in absorbed dose in rads. Its future use is inevitable, so why not

begin now? (3) If you cannot bring yourself to use rads routinely and must use roentgens, use the terminology "exposure dose in roentgens." This is acceptable up to 3 Mev only.

For the radiological physicists there are two recommendations: (1) Calibrate in roentgens per unit time for energies below 3 Mev. Use a good commercial thimble chamber designed for the energy for which it is used and calibrated by a standardizing laboratory at that same energy. Do not use rads for calibrating instruments where roentgens are appropriate. (2) Calibrate in rads per unit time for energies above 3 Mev. Measurements should be made at the peak of the ionization curve in a suitable water or plastic phantom. Use the Bragg-Gray principle to obtain rads from electrostatic units per cubic centimeter. Determine the electrostatic units per cubic centimeter in one or both of the following ways: Make a chamber of known volume and measure the current in absolute units. Calibrate a thimble chamber at Co^{60} energy and assume that 1 r gives 1 esu/cm^3 . These two methods should agree within about 5 per cent.

Conclusion

In conclusion, it seems appropriate to remark that the era of confusion and controversy in supervoltage dosimetry is not yet over, but the end appears to be in sight. This is due to the adoption of the rad as the basic unit of dose to tissue and to the development of reliable and consistent methods of dose measurement. These are mainly ionization measurements based on the Bragg-Gray principle verified by calorimetric standards.

Acknowledgments

Much of the material of this talk is based on discussions with F. H. Attix, J. Dutreix, J. S. Laughlin, H. H. Rossi, and H. O. Wyckoff; these discussions are hereby acknowledged with gratitude.

References

1. H. E. Johns and J. S. Laughlin, Interaction of Radiation with Matter, pp. 50-123, in "Radiation Dosimetry," G. J. Hine and G. L. Brownell, editors, Academic Press, Inc., New York, 1956.
2. F. W. Spiers, Radiation Units and Theory of Ionization Dosimetry, pp. 1-47, in "Radiation Dosimetry," G. J. Hine and G. L. Brownell, editors, Academic Press, Inc., New York, 1956.
3. J. S. Laughlin, "Physical Aspects of Betatron Therapy," Charles C Thomas, Publisher, Springfield, Ill., 1954.
4. L. D. Marinelli and L. S. Taylor, The Measurement of Ionizing Radiations for Biological Purposes, pp. 145-190, in "Radiation Biology," Volume I, Part 1, A. Hollaender, editor, McGraw-Hill Book Company, Inc., New York, 1954.
5. National Bureau of Standards, Handbook 55, Protection Against Betatron-Synchrotron Radiations Up to 100 Million Electron Volts, Superintendent of Documents, U. S. Government Printing Office, Washington 25, D. C., February 1954.
6. H. O. Wyckoff, personal communication, July 1956.
7. M. Danzker, J. S. Laughlin, and A. Liuzzi, Conversion of Roentgens to Rads, Fourth Annual Meeting, Radiation Research Society, Chicago, Ill., May 17-19, 1956 (to be published in Radiation Research).
8. J. W. Boag, Ionization Chambers, pp. 153-212, in "Radiation Dosimetry," G. J. Hine and G. L. Brownell, editors, Academic Press, Inc., New York, 1956.
9. W. J. Ramm, Scintillation Detectors, pp. 246-298, in "Radiation Dosimetry," G. J. Hine and G. L. Brownell, editors, Academic Press, Inc., New York, 1956.
10. R. A. Dudley, Photographic Film Dosimetry, pp. 300-355, in "Radiation Dosimetry," G. J. Hine and G. L. Brownell, editors, Academic Press, Inc., New York, 1956.
11. G. V. Taplin, Chemical and Colorimetric Indicators, pp. 358-410, in "Radiation Dosimetry," G. J. Hine and G. L. Brownell, editors, Academic Press, Inc., New York, 1956.
12. J. S. Laughlin and S. Genna, Calorimetric Methods, pp. 411-452, in "Radiation Dosimetry," G. J. Hine and G. L. Brownell, editors, Academic Press, Inc., New York, 1956.
13. U. Fano, Principles of Radiological Physics, pp. 1-144, in "Radiation Biology," Volume I, Part 1, A. Hollaender, editor, McGraw-Hill Book Company, Inc., New York, 1954.
14. F. W. Spiers, Effective Atomic Number and Energy Absorption in Tissues, Brit. J. Radiol., 19: 52-63 (1946).
15. H. E. Johns, X Rays and Teleisotope Gamma Rays, pp. 532-596, in "Radiation Dosimetry," G. J. Hine and G. L. Brownell, editors, Academic Press, Inc., New York, 1956.
16. J. Dutreix, personal communication, July 1956.

Distribution of Dose from Beams of Radiation

CHAPTER 2

T. A. Chalmers

Radium Institute
Liverpool, England

Abstract

The methods used for the determination of the distribution of dose in a collimated beam from a source of ionizing radiation, which is nearly a point source, as modified in an absorbing and scattering medium are reviewed. The advantages and limitations of the photographic method and of condenser ionization chambers for the determination of spatial distribution in a phantom are discussed. Recent experience with moving-field therapy techniques has indicated that a direct measurement by condenser ionization chambers embedded in a heterogeneous phantom, simulating body tissues in effective atomic number and electron density, appears to offer the most practical solution to the problem of finding the isodose curves for a planned treatment.

For the physical planning of moving-field therapy techniques, a computer based on a novel system, an electronic rotational isodose computer (ERIC), is suggested for a quicker solution of the problems that arise.

Introduction

The spectrum of the radiation used in cancer therapy is very wide and ranges from the 10 kv of the beryllium-window X-ray tube to the 50 million volts from a synchrotron. There is, in addition, a wide range of focal-to-skin distances (FSD), varying from the 1.5 cm from a short-distance therapy tube up to meter distances with some of the applications of the betatron and synchrotron; but the general principles are unchanged. If the radiation is collimated and emitted from a point source, or nearly a point source, there would be, in a nonabsorbing and nonscattering medium, a distribution of radiation diminishing by the inverse-square law. In an absorbing and scattering medium this is decreased by the effective absorption coefficient in the medium. If f is the FSD and d is the distance below the skin, the depth dose is

$$\frac{D_f}{D_0} = \left(\frac{f}{f+d} \right)^2 e^{-\mu d}$$

where μ is the effective absorption coefficient. In the lower energy range, absorption is mainly by the photoelectric effect; in the intermediate range, by the

Compton effect; and in high-energy ranges (above 1 Mev), by a pair-production effect, probably quite small, in the energies from the beam units currently available. At higher energies (above the threshold of the photonuclear disintegration effect), induced radioactivity is considered to contribute less than 1 per cent.

The composition of standard man is approximately 85 per cent water and 15 per cent protein and is of average density unity but ranges from 0.3 for lung tissue to 1.85 for bone. Most of the measurements of isodose curves have been made in the convenient unit-density material, water and simulated tissue, in the form of various loaded waxes. It is important to remember that the conventional depth-dose and isodose charts have been measured in a large homogeneous phantom of soft-tissue-equivalent material. This fact limits their strict application in practice. As will be seen later, for some dose distributions a heterogeneous phantom with varying densities must be constructed.

Advantages and Limitations of the Photographic Method

The photographic method is, of course, extremely wave-length dependent, as may be seen from the classical experiment of the spectrum of X rays from a tungsten target thrown upon a photographic emulsion; there is a definite K absorption edge of the silver atoms at 0.48 A or 26 kv and also a K absorption edge of bromine at 0.92 A or 13.2 kv. A densitometer curve of the photographic density per roentgen plotted against wave-length distribution shows that the sensitivity increases nearly 30 times as the K absorption edges of silver and bromine are reached. Provided we can get energies above 0.5 Mev and the range above the K absorption edges of silver and bromine can be maintained, the photographic method can be used as a first attempt to get the distribution of the beam, with the reservation that the film is calibrated for the quality of the radiation used. The energy

distribution of a collimated beam can be demonstrated simply by radiographs taken with the film edge on to the beam, an example of which shows the penumbra that occurs with a source other than a point source. Radiographs taken in this way can indicate the distribution in air and also in a phantom to demonstrate the scatter outside the geometric edge of the beam. A pinhole picture taken through a lead shield will indicate the effective size of the source and whether the collimation system of the beam was adequate for the size revealed.

One of the earliest attempts to obtain isodose curves for a moving field in rotational-therapy techniques used the photographic method.

Condenser Ionization Chambers

The general principles having been established, some type of small ionization chamber, thin- or thick-walled is needed, but it must be related to a primary calibration at one of the international standardizing laboratories. One of the most practical of these in wide use is a Victoreen dosimeter with a thimble ionization chamber. It has been found that the limiting factor is the effect of high-energy radiation on the insulator. No insulation other than amber appears to stand up to high-energy radiation. Most of the other insulators, polystyrene and polytetrafluoroethylene, show a slight conductivity for days and perhaps weeks after irradiation. It seems essential to use pure amber insulation for the central electrode of the thimble and condenser ionization chambers. The central electrode is charged by some convenient device and the residual charge after irradiation is measured. One of the most convenient instruments for this is the valve electrometer,¹ in which an electrometer triode follows the potential, which is read directly on a meter that can be calibrated in roentgens or rads. The circuit is stable with the negative feedback, and it is a much less fragile instrument than any electrostatic device. It is sometimes necessary to get small cylindrical ionization chambers that can actually be introduced into body cavities, swallowed in the esophagus, and for a direct measurement, if necessary, introduced inside bone. One of these, illustrated in Fig. 1, was made by J. E. Roberts of the Middlesex Hospital, London, and some of the finest ones in use were made at the Physical Laboratory of Radiumhemmet, Stockholm, under the direction of R. M. Sievert.

In the course of the last 20 years, an enormous amount of basic work has been done in determining the energy distribution of radiation in unit-density phantoms. Summaries of the central-axis depth-dose data for qualities of radiation of varying half-value layers have been collected and published, e.g., Supplement No. 5 of the British Journal of Radiology (Scientific Subcommittee of the Hospital Physicists Association, 1953). For any one quality of radiation and FSD, some 60 different applicator and field sizes and, in addition, wedge filters can be used; thus the routine work involved in determining isodose curves for each field is considerable for a busy radiotherapy depart-

ment. Table 1 shows a brief summary of the various methods that have been evolved to solve this problem. Originating with the analysis of Clarkson,² for fields of irregular shape, a number of semiempirical attempts have been made to break down the data. The method of Meredith and Neary³ analyzes the contribution from the primary beam and the addition from scatter

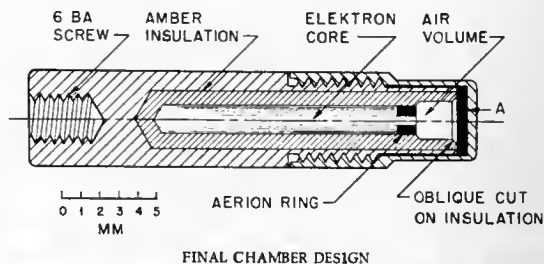

FINISHED CHAMBER

Fig. 1—Intracavitary ionization chamber.

Table 1—METHODS OF PRODUCTION OF ISODOSE CURVES

Method	Authors	Reference to Brit. J. Radiol.
Survey central-axis depth-dose data	W. V. Mayneord and L. F. Lamerton	14: 255 (1941)
Fields of irregular shape	J. R. Clarkson	14: 265 (1941)
Radiographic check of beam width	D. E. A. Jones	15: 178 (1942)
Isodose curves from scatter integrals, eight sectors	W. J. Meredith and G. J. Neary	17: 75 (1944) 17: 126 (1944)
Circular-slide-rule computer	J. H. Martin	19: 343-346 (1946)
Measurements by automatic exploring thimble chamber	L. A. W. Kemp	19: 488-501 (1946)
Isocontribution charts	L. F. Lamerton and M. Winsborough	23: 236-244 (1950)
Optical integrator light-flux comparator	B. M. Wheatley	24: 388 (1951)

integrals from sectors of fields of larger size, and the optical integrator of Wheatley⁴ can compute the data based on this analysis; both have found great application in British radiotherapy centers for computing isodose curves from central-axis depth-dose data.

Direct measurements have also been made by automatic exploring ionization chambers in water phantoms. Kemp⁵ described the prototype of the comparator exploring chambers. In it the ratio between the surface dose to depth dose is set, for example, at 10 per cent. An ingenious mechanism driven by servomotors drives the ionization chamber around the isodose curve. Such exploring mechanisms have been made automatic. At the Oak Ridge Institute of Nuclear Studies one such chamber that can be switched on and left over the week end has been developed.

It might be mentioned that workers in a busy radiotherapy department can minimize their errors. Much of the variation in surface-dose intensity with 250-kv X ray is due to the change in the percentage of backscatter. Supplementary filters can compensate so that the surface dose of all applicators is the same.

For beam teletherapy the potential sources are cesium, iridium, cobalt, and, to a limited extent, tantalum. It is unlikely that the high energy, e.g., 2.7 Mev, from Na²⁴ can be used. High-energy gamma radiation seems to occur only with short-lived isotopes. To be practical, we shall be concerned with the range of 0.67 Mev of cesium to 1.312 Mev of cobalt. When realizing the dose in rads, the higher the energy the closer together becomes the absorption in bone, muscle, and fat in so far as atomic number is concerned. The factor that becomes important is the density of tissues ranging from 0.3 for lung to 1.8 for bone, which produces a distortion of the isodose curves. For this reason we have attempted to construct a heterogeneous phantom.

Heterogeneous Phantom

The choice of materials for the construction of a heterogeneous phantom is conditioned by the fact that the insulation of the condenser ionization chambers is easily ruined by any moisture, and therefore it is desirable that the materials be dry. Table 2 lists some materials that are readily available. For simulating soft tissue, the material⁶ Mix D can be machined, cast, and drilled and has been proved satisfactory in all electron density and absorption tests. Lincolnshire bolus,⁷ consisting of small hard spheres of sucrose and magnesium carbonate about 2 mm in diameter, can be readily poured and used to fill up interstices and holes in the Mix D wax drilled to position the condenser ionization chambers. It has proved to be a useful granular material with radiation-absorbing properties similar to soft tissue. For a lung phantom (assumed density, 0.3 g/cm³), granulated cork, sawdust, or a mixture of granulated cork and a cereal⁸ filled into a plastic shell gives a reasonable substitute for lung tissue.

To prepare phantom bone, we obtained a processed skeleton from an anatomical dealer in London and measured the density. This proved to be too low, in some cases only 0.79 g/cm³. In fact, some bones floated at neutral buoyancy in ethyl alcohol. Obviously the anatomical processing had taken so much from the

skeleton (trabecular bone, not cortical bone) that it had to be replaced. Previously attempts had been made to replace this with paraffin wax, which was found to be too low in density. We therefore attempted to use Mix D (polyethylene, paraffin wax, and magnesium and titanium oxides) for this purpose. It can

Table 2—HETEROGENEOUS PHANTOMS, SUMMARY OF MATERIALS AVAILABLE

Material	Composition	Reference
Tissue phantom:		
Mix D, machined and cast by pouring at 120°C	Paraffin wax, 60.8 wt. % Polyethylene, 30.4 wt. % Magnesium oxide, 6.4 wt. % Titanium oxide, 2.4 wt. %	D. E. A. Jones and H. C. Raine, Brit. J. Radiol., 22: 549 (1949)
Lincolnshire bolus, small hard spheres 2.3 mm in diameter	Sucrose, 87 wt. % Magnesium carbonate, 13 wt. %	D. D. Lindsay and B. E. Stern, Radiology, 60: 355 (1953)
Lung phantom, density, 0.3 g/cm ³	Granulated cork, bulk density, 0.1 Grape Nuts cereal, bulk density, 0.46	M. Cohen, Brit. J. Radiol., 28: 669 (1955)
Bone phantom, density, 1.85 g/cm ³	Plaster of Paris, anatomical skeleton vacuum impregnated with Mix D	R. O. Kornelson, Brit. J. Radiol., 27: 289 (1954); T. A. Chalmers, 1956

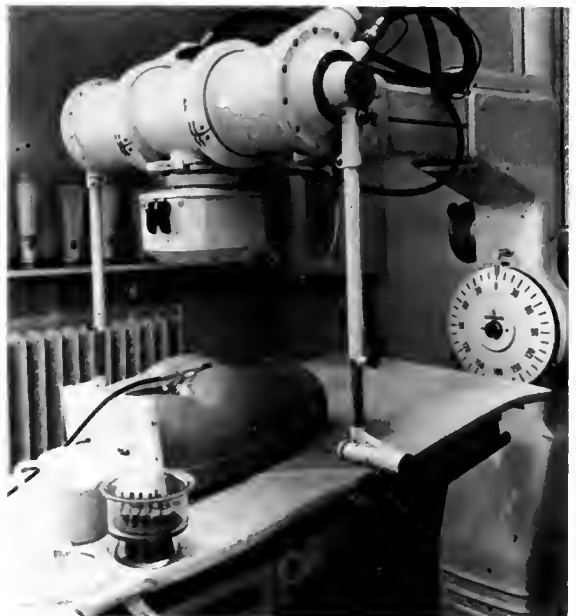

Fig. 2—Heterogeneous phantom containing plasticized skeleton and Lincolnshire bolus.

be done by melting the Mix D in a container under reduced pressure; the bone then becomes plasticized, almost reverting to its natural state. It is quite solid and can be drilled for the insertion of condenser chambers. The density varies from that of relatively coarse cancellous bone of 1.1 g/cm³ to 1.4 g/cm³. Only the hard cortical bone has a density of 1.85 g/cm³. This closely simulates measurements made

on post-mortem specimens of bone. The skeleton is assembled in a plastic shell, care being taken to avoid the use of materials of high atomic number in articulating and mounting the bones. Figure 2 illustrates the pelvic section of a heterogeneous phantom (named "Heterogenea") constructed in this manner. It is being used for the determination of isodose curves from a moving-field therapy unit (Pendulum Therapy X-ray Unit).

Moving-field Therapy

The transfer from a stationary isodose curve to the isodose curves resulting from a moving field has been puzzling workers for the last 10 years because of its extreme complexity. It is not surprising that in an early attempt (and one of the most promising) the photographic method was used, which succeeded as a first intensity distribution with the radiation from a 2-Mev electrostatic generator, as well as a 2-Mev resonant transformer generator. Other workers have attempted to use different methods of automatic computation, the so-called "analogue" computers. One of these used the potentiometer to simulate the dose rate, but in this case a number of assumptions were made: none of the side-scatter from the beam was included, and the isodose curves were assumed to be flat. Much of the work on rotational therapy has been solved by the sector method, i.e., dividing the cross section to be treated into sectors, taking the 360 degrees and dividing 12, 18, or 36 times. This involves a considerable amount of work in computing the distribution from rotation. One ingenious device to achieve this integration has been a disk and wheel computer. A major project has been the transfer of the isodose curves to punch cards on a polar-coordinate system; to summate the data, 36 sectors of 10 degrees each are fed into a punch-card tabulator. I am proposing yet another system, based on a novel principle that will be described later.

The convergent-beam type of rotational therapy appears to be incapable of solution by these computers and must of necessity be measured by condenser ionization chambers fixed in a phantom. Many condenser chambers can be exposed simultaneously and measured individually with an electrometer.

The apparatus assembled for the measurement of these isodose curves is shown in Fig 3. Condenser ionization chambers are inserted in holes drilled in a slab of Mix D and positioned in a polyethylene container. The interstices are filled with Lincolnshire bolus.

In some of the refinements of rotational therapy, the beam can be eclipsed halfway round the circuit in order to achieve crescent-shaped isodose curves. In certain rotating-therapy techniques it is essential to screen off certain sectors with lead shields, e.g., the femoral neck, which could be fractured by the absorption of excessive radiation.

It seemed desirable to attempt the design of a computer to solve these problems. In summing the contribution from multiple fields, the only practical

method [see Chap. 3, Fig. 7a, on page 21] appeared to consist in totaling the figures. A photometric method did not succeed; there were difficulties in stabilizing the light source, and the laws of absorption of light in tinted sheets are geometric and not arith-



Fig. 3—Measurement of isodose curves from a convergent-beam therapy unit.

Table 3—MOVING-FIELD THERAPY, METHODS OF DETERMINING ISODOSE CURVES

Method	Authors	Reference
Photographic comparator method, 2 Mev	J. G. Trump et al.	Am. J. Roentgenol., 72: 302 (1951)
Electrical analogue computer, 2 Mev	W. S. Moos and E. W. Webster	Radiology, 59: 729 (1952)
Tumor-air ratio, 18 × 20 deg sectors, Co ⁶⁰	H. E. Johns et al.	J. Can. Assoc. Radiologists, 4: 1 (1953)
Computer, disk and wheel integration	J. E. O'Connor	Brit. J. Radiol., 26: 453 (1954)
Punch-card tabulator, 36 × 10 deg	K. C. Tsien	Brit. J. Radiol., 28: 432 (1955)
Computer, Dekatron scaler integration of beta-ray thickness gauge	T. A. Chalmers	(1956)

metic. One answer appeared to be to substitute a source of beta rays from a radioactive isotope, use the beta-ray gauging principle, and integrate by a Geiger counter and scaler.

Table 3 lists some of the methods of determining isodose curves in moving-field therapy.

Electronic Rotational Isodose Computer

The absorption of beta rays in matter is solely dependent upon the mass per unit area. This principle is used extensively in manufacturing paper and sheet

metal and in packaging cigarettes in the so-called "beta-ray thickness gauge." A convenient source is the strontium-yttrium beta-ray one with a 20-year half life and an electron energy of about 2.2 Mev. These beta rays are absorbed in about 3 to 5 mm of various light materials, such as plastics, paper, and aluminum foil. The isodose curves, instead of being drawn as lines on a sheet, are translated to a step wedge com-

electronic rotational isodose computer (ERIC).

Conclusion

In summary, we make use of all available data on central depth-dose curves measured in unit-density phantoms. We endeavor to apply this in practice by making direct measurements in heterogeneous phan-

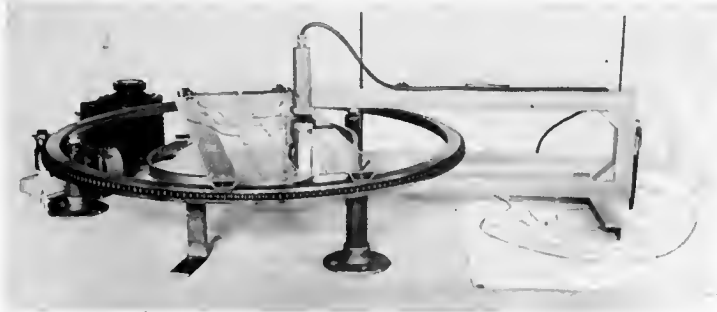

Fig. 4—ERIC, based on the principle of the beta-ray thickness gauge.

posed of sheets of appropriate light material such that the 100 per cent isodose curve transmits 100 per cent of the beta rays, the 10 per cent isodose curve transmits 10 per cent of the beta rays, etc. A prototype computer based on this principle has been constructed; in it the isodose curve is moved in an appropriate manner to intercept the beta rays from the source to the detector connected to an integrating circuit.

A disk 60 cm in diameter, which can be rotated at the rim by an electric motor, carries a radial slide system on which the isodose curve can move freely. The movement of the isodose curve is controlled by a cam that simulates the contour of the cross section of the patient whose treatment is being prescribed. This replica of the body contour is easily made up for each case individually of channeled brass curtain railing. For clarity, in Fig. 4, the opaque screens are removed to show the working principles, but in operation screens exclude transmission outside the beam of radiation. The source of beta rays is collimated to a beam 1 cm in diameter; the detector is an end-window beta-ray Geiger counter, connected to a scaler (Dekatron) of the conventional type, but in a refinement this can be of the printing register type. In operation the rim drive motor is switched on, and, after a complete revolution in about 20 sec, the scaler gives an integrated value of the dose at the point of interest in the body contour. For partial rotation, arc, pendulum, or sector therapy, microswitches on the contour are set to switch off the scaler to simulate the radiotherapy technique. The coupled source and detector are then moved to another point of interest within the body contour, and the integrated dose at that point is also plotted. In this manner, when sufficient points have been obtained, it is possible to transfer a stationary isodose curve to a rotational one in about 20 min.

It is convenient to give a simple name to such a computer, and it seems appropriate to call this one an

toms such as Heterogenea. For the physical planning of complex field setups and moving-field therapy, it is hoped that ERIC can be used as a predictor to plan the treatment schedule (the angle of arcs etc.). ERIC predictions should be checked by direct measurement on the heterogeneous phantom. Finally, if at all possible, a direct measurement on the patient, in any body cavity available, appears desirable. Experience in conventional therapy techniques, e.g., with 250-kv X rays, has shown that the dose in the esophagus can be 40 to 80 per cent greater than that predicted from isodose curves measured in unit-density phantoms. This is due to transmission through lung tissue. Dosages measured in bone can be 40 per cent less than the isodose curves indicate. It is concluded that on all possible occasions direct measurements by condenser ionization chambers in a heterogeneous phantom offer the most practical solution.

References

1. F. T. Farmer, Direct-reading Random Meter for Clinical Purposes, *Brit. J. Radiol.*, 15: 318-319 (1942).
2. J. R. Clarkson, Note on Depth Doses in Fields of Irregular Shape, *Brit. J. Radiol.*, 14: 265-268 (1941).
3. W. J. Meredith and G. J. Neary, Production of Isodose Curves and Calculation of Energy Absorption from Standard Depth Dose Data, *Brit. J. Radiol.*, 17: 75 (March 1944); 17: 126 (April 1944).
4. B. M. Wheatley, Radiotherapeutic Physics. VII. An Instrument for Dosage Estimation with Fields of Any Size and Shape, *Brit. J. Radiol.*, 24: 388-391 (July 1951).
5. L. A. W. Kemp, The Exploration of X-ray Dose Distribution: An Automatic Method, *Brit. J. Radiol.*, 19: 488-501 (1946).
6. D. E. A. Jones and H. C. Raine, correspondence in *Brit. J. Radiol.*, 22: 549-550 (1949).
7. D. D. Lindsay and B. E. Stern, New Tissue-like Material for Use as Bolus, *Radiology*, 60: 355-361 (March 1953).
8. M. Cohen, The Patient and the Roentgen, Part I, *Brit. J. Radiol.*, 28: 669-677 (1955).

Methods of Calculation and Planning of Tissue Dosage

CHAPTER 3

Sven Benner

Sahlgrenska Sjukhuset
Gothenburg, Sweden

Abstract

This chapter gives a general survey of current methods for dose-distribution calculation and dose planning for plane and three-dimensional stationary-field arrangements and for rotation therapy.

Special advantages, from a physical point of view, of gamma-beam and supervoltage radiation, as compared with conventional 200- to 250-kv X rays, are increased relative depth dose; less side-scatter and back-scatter, resulting in reduced skin dose and integral dose; less energy absorbed in bone and cartilage; and less shadowing by bone. The lesser disparity in absorbed dose among different tissues, i.e., lung, fat, muscle, and bone, improves the accuracy of dose calculation. These calculations are usually made with the aid of standard dose-distribution diagrams or tables constructed from measurements in a homogeneous material, usually water. In conventional X-ray therapy uncritical use of such standard diagrams can cause considerable errors, as shown by Fig. 1, which gives the distribution of energy absorption in a neck irradiated with radium gamma rays and 140-kv X rays. Distances are adjusted to give the same distribution in water (curve C). Curve A shows the energy absorption for radium gamma rays, and curve B, for X rays. It is evident that the energy-absorption distribution differs from the standard depth-dose diagram. With hard gamma rays there is a smaller differentiation; in fact, there is less absorption in bone and less shadowing by bone than there is with soft X rays. When lungs or air-filled cavities are in the path of the rays, even larger differences occur, but in the opposite sense to those caused by bone.

This type of dose-distribution calculation should be carried out prior to each treatment on the basis of a choice of radiation quality (in which respect one is, of course, restricted by the equipment available) and other conditions [focal-to-skin distance (FSD), field size, and arrangement of portals]. Choice of the latter factors is determined by experience and by an in-

tuitive feeling for the arrangement that would provide an adequate and reasonably constant dose over the entire tumor area and would give as low a dose as possible to surrounding healthy tissues and skin. Skin tolerance is no longer an important limiting factor in the irradiation techniques now being considered, as in conventional X-ray therapy. Furthermore, the integral dose should be as low as possible.

It will frequently be found that the dose distribution calculated from the treatment plan is not so good as was hoped. One then must vary the different factors and try a new arrangement of fields in an effort to find a better distribution. Several different arrangements should be tried in succession until a satisfactory one is found. This procedure of trial-and-error dose calculation I call the "dose planning." For this purpose an efficient radiotherapy department requires a number of experienced hospital physicists, although much of the routine work can be done by assistants with less technical training.

It is also necessary to have a large number of standard diagrams for various radiation qualities, field sizes and shapes, and treatment distances. In principle, these diagrams should all be in three dimensions. Only in circular fields with a central beam perpendicular to the surface of entry is all relevant information contained in one isodose diagram based on a plane through the central beam. For square fields such a diagram would not lead to serious errors except near the corners. In elongated fields of rectangular, elliptical, or other shape, a practical compromise is achieved with diagrams in two or three different planes.

These diagrams are based on measurements in homogeneous phantoms. Empirical corrections are approximated for bone and air-filled cavities and for the dose deficit near exit surfaces due to the reduced back-scatter. This latter factor is less important in gamma-beam and supervoltage therapy than in conventional X-ray therapy.

For a comprehensive dose calculation dose contributions from different fields to each point in the

radiation area are ascertained and added together. In practice this is done for a limited number of points over the area to be treated. The points need not be so closely spaced when the total dose varies slowly with position as they do in regions where this variation is rapid. Isodoses in different planes can then be

time needed when several different field arrangements are tried, dose calculation and planning has often been limited to cases in which the central rays of each field are in the same plane, and the calculations are usually limited to that plane. It is clear, however, that this can seriously limit the possibilities of find-

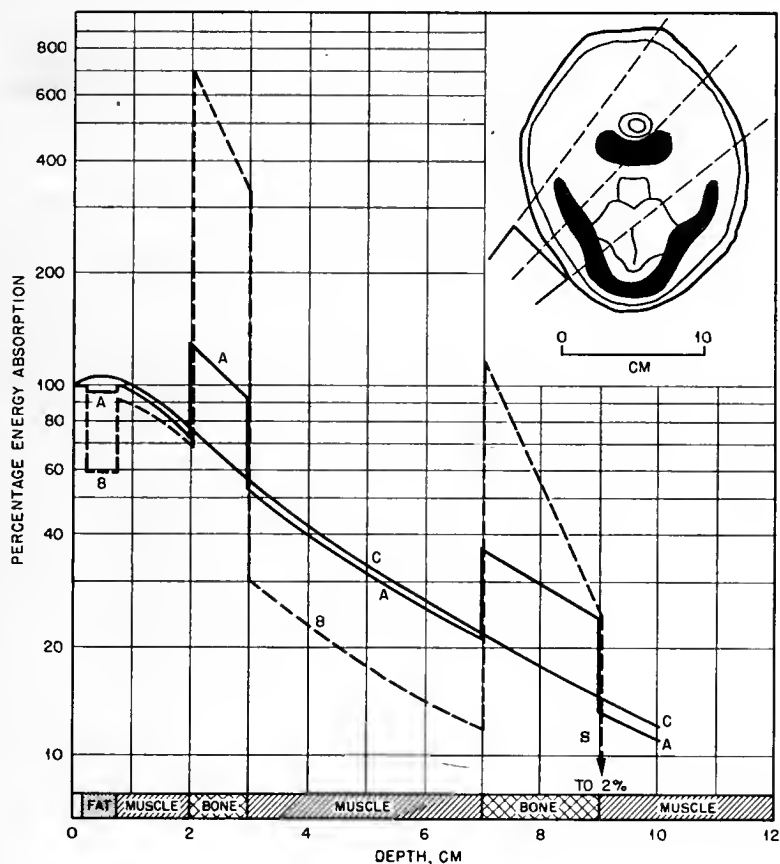

Fig. 1—Energy absorption in different parts of a neck irradiated by radium gamma rays (curve A) or 140-kv X rays (curve B); the distances in both curves are adjusted to give the same formal distribution (curve C). (From H. E. Johns, "The Physics of Radiation Therapy," Charles C Thomas, Publisher, Springfield, Ill., 1953, by courtesy of the author and the publisher.) Percentage energy absorption for a field directed through the lower jaw into the tonsillar region by means of the following techniques:

Technique A, radium-beam unit. Field, 20 cm²; RSD, 5 cm; λ , 800 kev, 15 XU, or 0.015 A; depth dose at 7 cm, 22 per cent.

Technique B, 140-kv X-ray unit. Field, 22 cm²; FSD, 15 cm; λ , 50 kev, 240 XU, or 0.240 A; depth dose at 7 cm, 22 per cent.

Technique C, formal depth-dose tables. Data were taken from work by F. W. Spiers.

drawn for a number of round values of dose, expressed either in roentgens or in rads. (Somebody has suggested the term "riddles" to characterize the present position of the dose-unit question.)

On the other hand, the dose can be given at different points in percentage of maximum dose, tumor-center dose, or some other suitable standard value. These isodoses usually do not pass exactly through the points of calculation, but between them, in a manner found by graphical interpolation.

Because of the time required for a complete dose calculation in three dimensions and the still longer

ing the best possible arrangement of portals and of ascertaining the exact dose distribution.

The first step is to draw the contour of the body section of the patient in the appropriate plane. The contour is obtained by fitting a flexible lead ruler to the patient, making a plaster strip of cast, or some other method. This contour should be made with the patient in the position he is to occupy during actual therapy since the body shape can change considerably in different positions. The central ray of each proposed beam is drawn, and the points of calculation are marked. The appropriate isodose diagram, drawn

on transparent material, is then placed on the paper successively in the different positions. Often it will be necessary to use different diagrams for different fields. Dose contributions to selected points are noted, and the sum for the different points is calculated.

When the plane in question cuts important internal organs, these should be drawn on the same paper either with the aid of radiographs or the standard body sections obtainable. Unfortunately, many patients do not conform to standard cross sections. At the Argonne Cancer Research Hospital in Chicago, I have seen how Dr. Jennings solved this difficulty by modifying the standard section to conform to the patient instead of making the patient conform to the standard section. Standard sections are copied on small lantern

The patient's contour is to be taken with the patient in the treatment position; this also applies to the radiographs that may be taken. With radiographs one must take account of the magnification on the film.

Even with the limitation mentioned, adequate dose calculations and dose plannings occupy much time, and there is need for some kind of automation to speed up the work. Dr. Chalmers told of such a method. At the University of Illinois Research Hospital, I have seen Dr. Moos and his collaborators use isodose diagrams in the form of lantern slides, in which the light transmission in different points is proportionate to the relative depth dose. Slides corresponding to different fields are simultaneously projected onto a paper on which the body section has been drawn. One sees

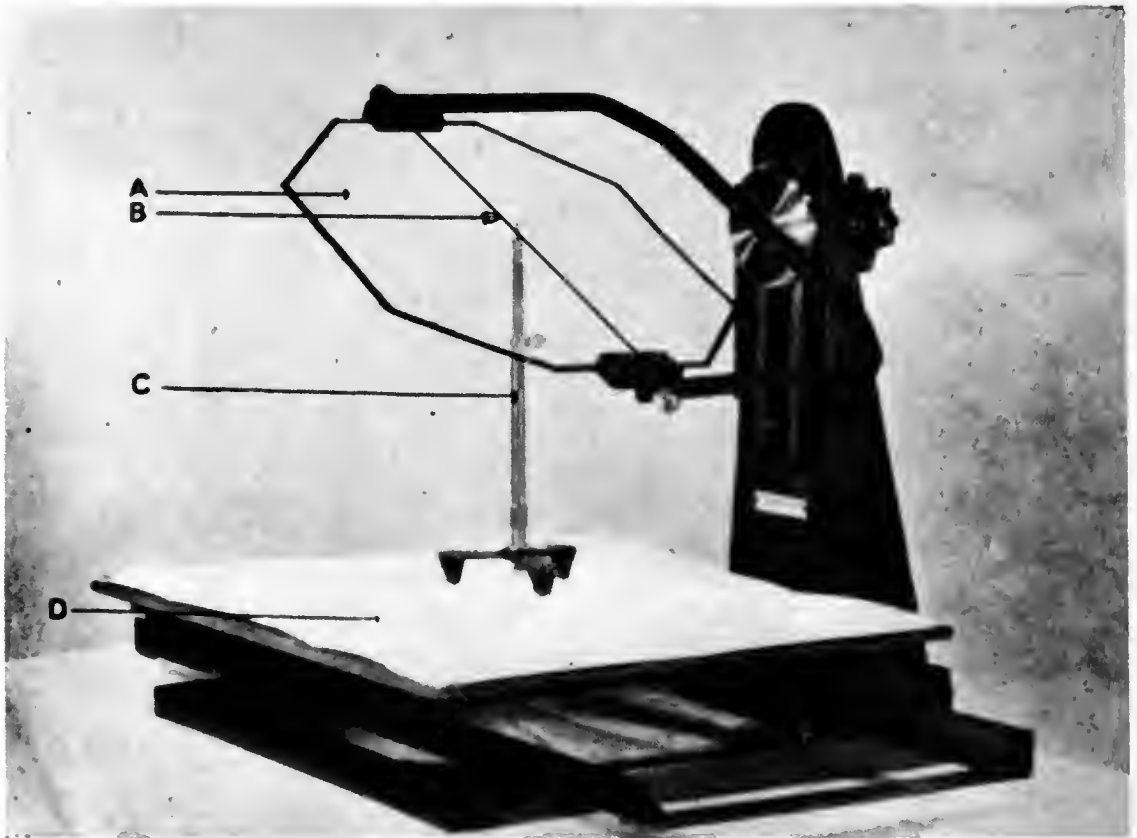

Fig. 2—Mayneord contour projector for the projection of isodose curves from the principal plane that includes the central axis on to any required plane. A, mount for isodose curves. B, axis of rotation for central axis of isodose curve. C, marker. D, drawing board. (By courtesy of W. V. Mayneord, D. W. Smithers, and the British Journal of Radiology.)

slides, which he projects on paper. The distance from the projector to the paper is adjusted until the standard section equals the patient's section in one direction. Then, to fit the standard section to the patient in a direction at right angles to the former, a stainless-steel mirror is bent in the path of the light beam until it assumes a cylindrical shape, concave or convex, with suitable curvature. The difference between the projected standard cross section and the patient's real cross section becomes inconsequential.

an illuminated field in which the light intensity is proportionate to the total depth dose at the several points.

This provides only a qualitative picture to the naked eye. To find the isodoses, one would have to make tedious photometric measurements. Dr. Moos solved this problem by viewing the projected composite image with a television camera and transmitting it to an ordinary television receiver. This would seem to be an unnecessary complication, but it gives an interesting possibility.

Each isodose corresponds in the projected image to a line of equal light intensity, i.e., a certain signal amplitude from the camera tube. From proper setting of a potentiometer, the corresponding points on the receiver screen can be blacked out so that one sees a dark line corresponding to the isodose in question. By employing several potentiometers, several isodoses can be seen simultaneously. This picture is viewed and judged as to whether the isodose pattern is suitable. If the pattern is not suitable, the different projectors are moved to correspond to a different field arrangement, and the resulting isodose pattern is reviewed. This speeds up the trial-and-error method considerably.

To take care of the possibility of giving different skin doses to the different fields, the light powers of the projectors can be adjusted by varying the current to the different projector lamps. This method is, however, still in a preliminary experimental stage.

If we adhere to coplanar fields, the same methods of dose planning are applicable to other planes parallel to the first one, provided the standard isodose diagrams are available for such planes. For circular or near-circular fields, W. V. Mayneord's dose-contour projector (Fig. 2) can be used. The isodose diagram drawn on transparent material is attached to plate A, which can be turned around axis B on a frame. The frame itself can be turned around a horizontal axis in the stand and can be raised and lowered. Marker C is moved around on the paper D, and the diagram is turned and the pointer is moved until its upper point just touches a certain isodose in the diagram. The corresponding point is then marked on the paper. For details I must refer to standard textbooks on radiological physics, e.g., "The Physics of Radiotherapy," by H. E. Johns, Springfield, 1953 and "Radium Therapy—Its Physical Aspects," by C. W. Wilson, London, 1956 [see Bibliography].

This contour projector can also be used for planes inclined to the axis plane and in fields that are not coplanar. However, it takes much time to use it. Several other methods on the same principles have been worked out, especially by British physicists.

One possibility is to visualize the isodose in a given plane with the aid of what one might call a "plane of light." This is a thin long beam of light from a long straight filament lamp with cylindrical lens and a long narrow slit. Isodoses can be constructed as a number of white-painted metal wires attached to a rod which can be made to rotate rapidly around a line corresponding to the central axis. The sections of the isodose surfaces with the plane of light then become visible and can be drawn on paper with the aid of a semitransparent drawing mirror.

At the Institute of Radiophysics, Stockholm, R. Walstam has worked out a method primarily for a short-distance so-called "head-and-neck unit," but it can readily be applicable also to other, larger units.

The apparatus (Figs. 3 to 5) is composed of elements consisting of short stout brass wires to which thinner wires are soldered. They are connected by standard clips and fitted to the patient (Fig. 4), the

numbered brass rods indicating the central rays of the several fields. The unit is then removed from the patient, and rods of different lengths (Fig. 3c) are attached, their free ends indicating points of interest within the patient for which dose calculations are

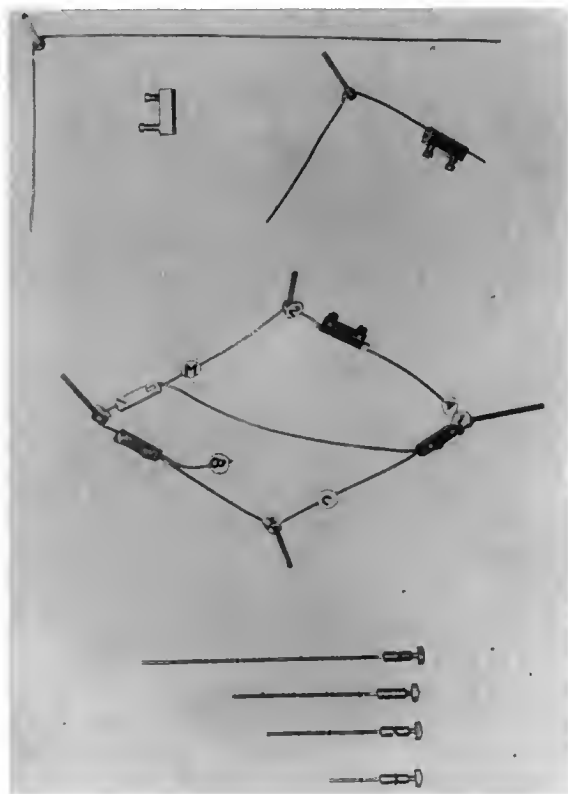

Fig. 3—Head-and-neck unit. (a) Components; (b) components connected to a frame; (c) components.

wanted. A small brass tube to which a flexible isodose diagram is attached is then slid over the brass rods in succession (Fig. 5), the corners are bent when needed, as Fig. 5 shows, and the plane part of the diagram is brought into contact with the several calculation-point indicators. The contribution from each field to these points can then be read. In Fig. 5, for example, 41 per cent contribution from field No. 2 to a calculation point a certain distance below point C on the skin is read.

As to dose calculation and planning in rotational therapy and other types of moving-field therapy, the beam is usually directed in a reproducible manner, as Dr. Chalmers stated, by replacing the continuously moving beam with a suitable number of stationary fields that are equally spaced. Because the FSD varies as the patient rotates, ordinary standard isodoses for fixed distances are less applicable. C. B. Braestrup and R. T. Mooney have solved this difficulty by referring all dose values to the air-axis dose, i.e., the dose that would exist at the axis of rotation if the patient were removed; this dose is, of course, fixed. They have constructed a scale (Fig. 6) giving the



Fig. 4—Frame being fitted to a patient.

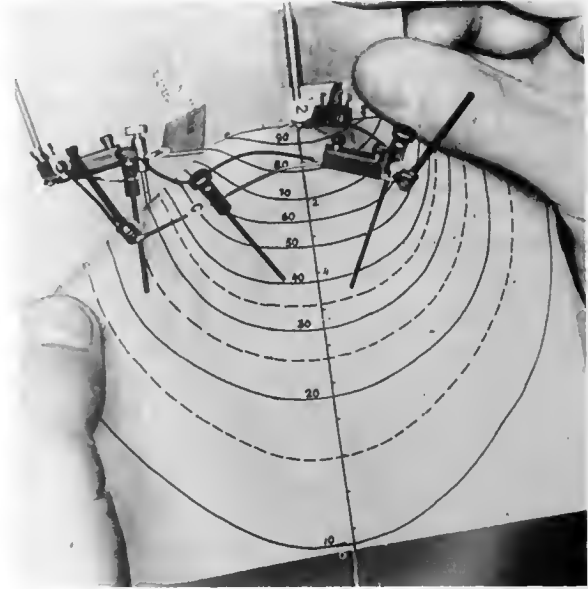

Fig. 5—Dose values being read from the device.

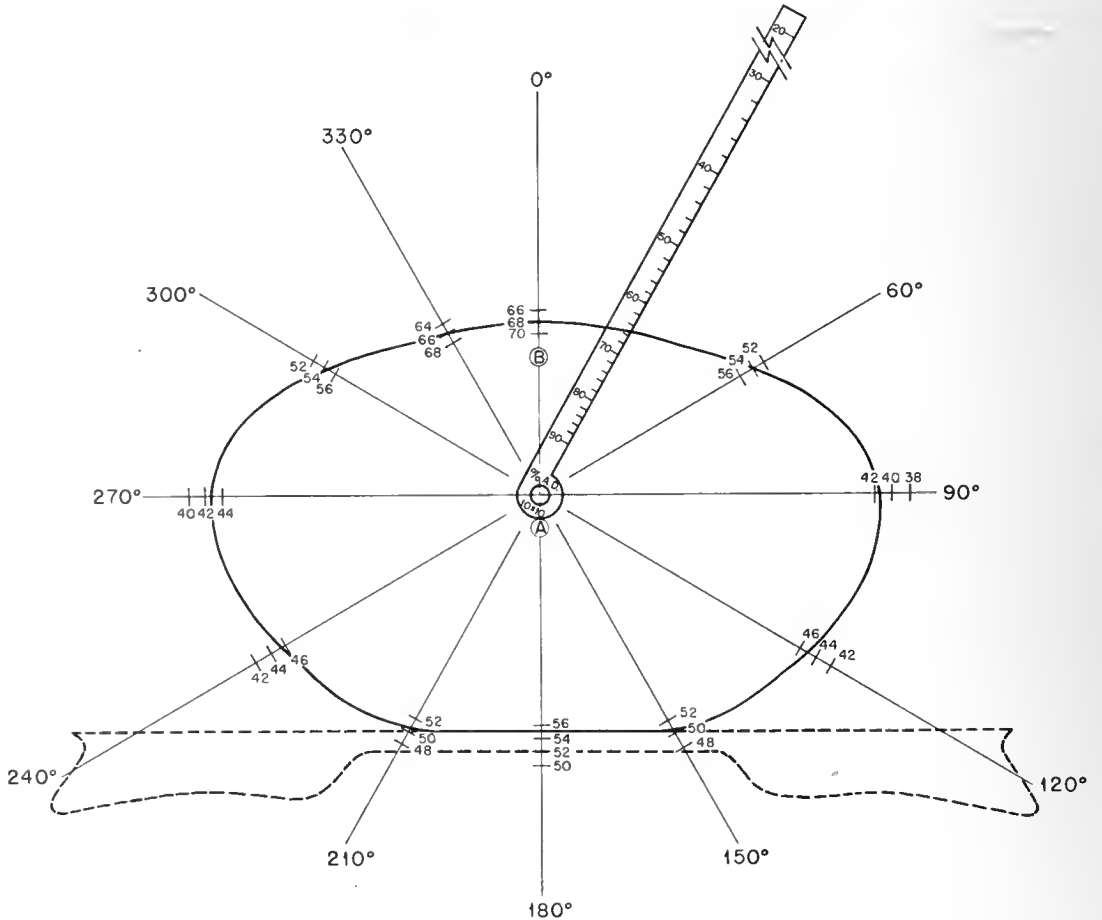

Fig. 6—Use of the Braestrup-Mooney graduated scale for axis dose calculation in rotation therapy. The percentage of center dose rate is determined for each 30-deg interval. - - - -, the tissue-equivalent cross section of the treatment couch.

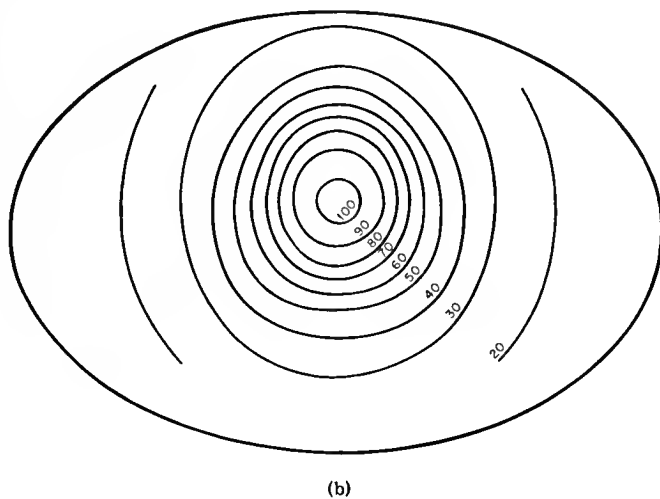
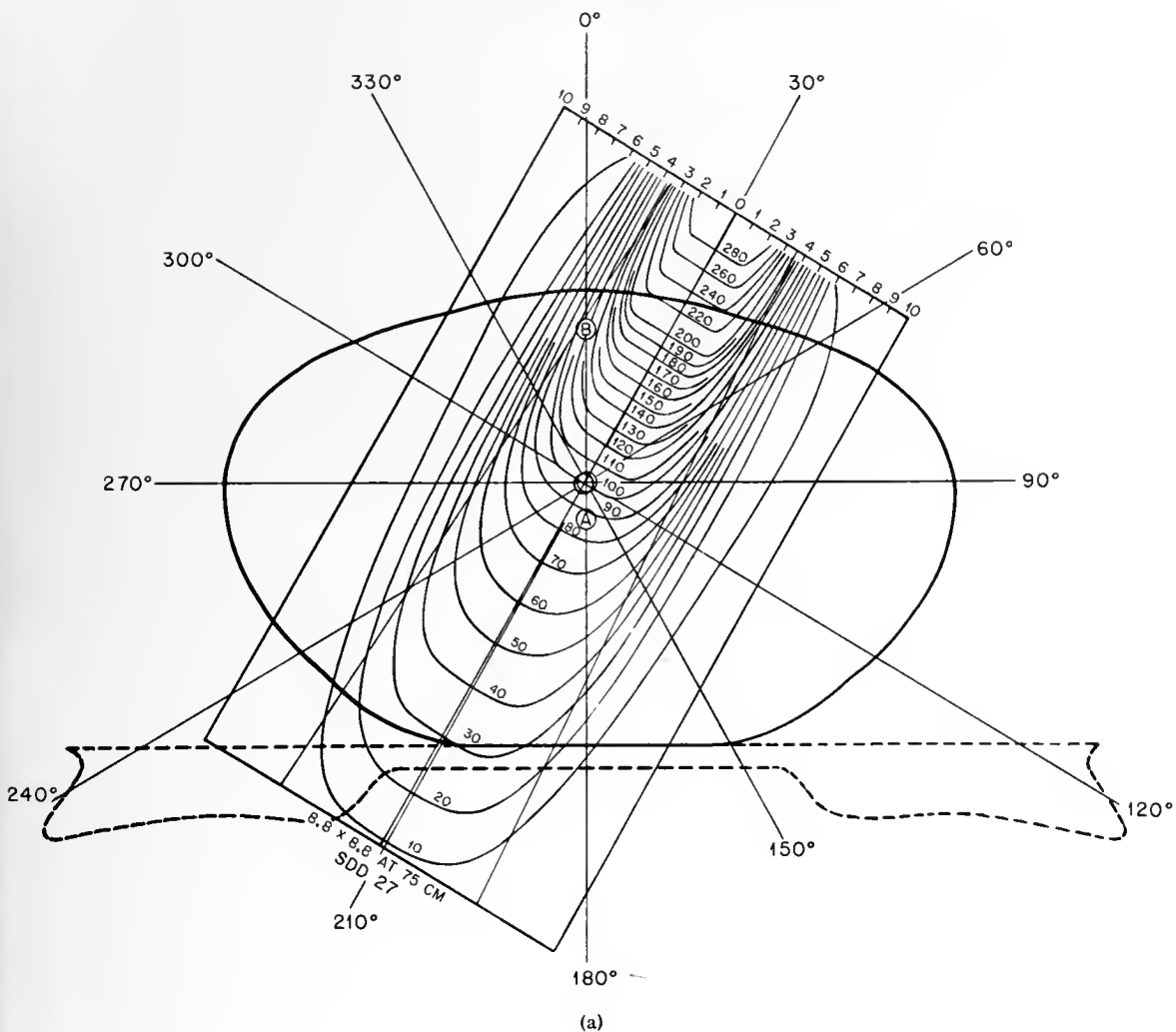

Fig. 7—Calculation of off-axis doses by the method of Braestrup and Mooney. (a) Determination of off-center dose rate, showing the contribution of the radial beam to the dose at points off center. (b) Typical isodose pattern used in the treatment of cancer of the cervix. Co^{60} therapy; 360-deg rotation.

actual axis dose rates as a percentage of the air-axis dose rate. The scale is placed on a body-section drawing and turned along different radii. The contribution for different fields is then read. The broken line corresponds to absorption in the table top, recalculated for tissue equivalents. Thus the reading for 210 deg is 15.8 and not 17.0 as read on the patient's contour surface. Averaging the values from different directions gives the value to be used.

The standard isodoses are then redrawn with the axis dose-rate value set at 100 per cent (Fig. 7). The dose at any other point off the axis (e.g., A or B in Fig. 7a) can be read with this diagram successively for different directions, and the sum can be found. Figure 7b shows a dose distribution calculated in this manner.

K. C. Tsien at the Memorial Hospital, New York,

uses the punch-card method for the calculation, and W. S. Moos and E. W. Webster at Massachusetts Institute of Technology used a combined mechanical-electrical integrator. For inclined-beam rotation P. R. Steed uses the Mayneord contour projector, previously described.

A few words should be added on the integral dose. This is primarily determined by radiation quality, field size, and thickness of the irradiated body part; the FSD is of secondary importance, provided it is relatively long. For an approximate calculation it would thus seem possible to have a set of tables of integral dose per rad of skin dose, maximum dose, rotation-axis dose, or any suitable unit for different values of these parameters. Then one simply adds the integral dose from the several fields in the treatment plan decided upon.

DISCUSSION

CHAPTER 4

Roberts: I have elected the first paper to discuss because it gives me personally an opportunity to refute an accusation that I have "assassinated" the roentgen. The roentgen is still a good unit, but it is not a good unit of clinical dose for radiotherapy. It is an excellent unit for measuring the air-ionizing power of X rays or gamma rays, but the two are not the same thing. It was encouraging to hear Dr. Loevinger's reasoned argument in favor of a unit of absorbed dose because there is a great need for clear thinking about the rad. There has been a lot of paper work on the rad, but perhaps not so much clear thinking.

Fundamentally there is only one method of measuring absorbed dose in rads, and that is a calorimetric method using ergs per gram or calories per gram. It might have been better if the unit had been defined in calories per gram, which is exactly the same thing, and we should have understood it better. Calorimetry is a difficult method, but it will be solved; in fact I have already seen, within the last week, some excellent attempts at radiation calorimetry in this country.

The next best, though rather despised, method of measuring dose in rads is the chemical method, which fundamentally is an indirect calorimetric method. Chemists can do nothing about chemical dosimetry unless they know the thermal chemistry of their reaction, which means that they can measure absorbed dose in ergs or calories.

For routine work we have to use ionization, but we should be careful about calling an ionization measurement in rads an absolute measurement. The conversion of an ionization measurement to an absorbed dose in rads depends on accurate knowledge of parameters, such as the energy per ion pair, the stopping power, and even the fundamental theory of ionization. Any of you who read *Radiation Research* will have seen some rather fearsome papers recently on the fundamental theory of cavity ionization chambers. I do not recommend them strongly to student radiotherapists; they are rather tough.

May I issue a little warning on loose talk about calibration of dosimeters in rads. It is not possible. We can have rads only in some medium, and therefore we have to talk about air rads, water rads, tissue rads, or bone rads, etc. A dosimeter calibrated in rads must have a dozen calibrations in different terms.

The effects of introducing rads into routine radiotherapy will not be very pronounced. Soft-tissue doses will be measured and prescribed in very much the same way as at present, and, if, in Mexico next week [Eighth International Congress of Radiology, Mexico City, July 1956], the values for the parameters for roentgen-to-rad conversions are agreed upon, it is probable that the conversion factor from roentgens to soft-tissue rads will be very near 1. If so, you can forget it.

We should think more clearly about surface dose. When it is measured with a surface dosimeter, we think it is measured in roentgens, but it is not. The main effect, however, should be better thinking about bone dose. It is unlikely that anyone will think seriously about detailed estimation of dose in bone in rads, but the calculation at a few points in bone will probably be made now in rads.

Again, one has to issue a warning about calculating bone dose. It is well to talk about hard bone as having a density of 2-point-something, having so much calcium and phosphorus, and so on. Even as a physicist, I am quite sure the clinician is not interested in the absorption in hard bone. Bone that is already dead cannot be killed.

What you are interested in is the effect of absorbed dose on the soft-tissue inclusions in bone, and these have been treated thoroughly, physically, in the Bragg-Gray cavity principle of having a cavity containing soft tissues surrounded by a wall of hard bone. The mathematics is exactly the same as that for an ionization chamber.

Unfortunately, in practice, these cavities vary in size from 1 to 100 μ or more. I know nothing about the anatomy of the Haversian systems, but it must be

something of that kind. The work of F. W. Spiers and others who have made approximations in order to estimate the absorbed dose to soft-tissue inclusions in bone should be commended. For example, for hard bone the roentgen-to-rad conversion as you go from 250-kv X rays to 2-Mv X rays, changes from 1.5 to about 10; whereas, if the effect on the soft-tissue inclusions in bone is calculated, the factor changes from about 1.2 to 2.5. These will be the factors by which you will have to multiply your ionization roentgens in order to get an idea of the effective absorbed dose in the bone.

I suggest that radiotherapists give more thought to absorbed dose in bone, not with an idea of drawing elaborate isodose distributions in bone. I do not think it can be done. Radiobiologists have time to work out their own absorbed doses in detail, but radiotherapists usually must have a quick answer, and I think it can be obtained if we stoop to approximation.

I do not think the rad is the final answer to all the physical problems of clinical radiotherapy, but it might help.

Tubiana: In radiotherapy we need two different units: a unit of exposure to define the output of the X-ray machine and the X-ray flux at the point of interest and a unit of dose to define the quantity of radiation which is absorbed.

Most of the confusion in clinical dosimetry arises from the use of the roentgen for both exposure dose and absorbed dose. The roentgen should now be used only for exposure dose, and the rad, for dose.

The roentgen characterizes the energy going through a medium; the rad measures the energy absorbed in this medium.

The absorbed dose is difficult to measure. When using the formula $E = WSJ$, it is necessary to know the value of two parameters and to measure the absolute number of ionizations in a small air cavity inside the medium. At present, when an absorbed dose is expressed in rads, the values of the parameters (W and S) and the technique used for ionization measurements must be specified.

Most of the commercially available ionization chambers have a so-called "air-equivalent wall" calibrated against standards at a certain energy. In fact, there is no wall that is air equivalent at all energies. Ignorance of the atomic composition of the wall, its thickness, and the volume of the chamber introduces difficulties in the interpretation of the result. Very thin-walled chambers (not necessarily air equivalent) of accurately known atomic composition and volume are needed.

For an X-ray beam of a given energy, the exposure is proportional to the number of photons. Exposure decreases with distance and absorption just as the flux of photons does. The density of ion pairs is, in first approximation, related to the population of secondary electrons. Ionization at a point C (Fig. 1) results from the interaction with matter of secondary electrons set in motion in each successive layer (dy) located proximal to C. If there were no photon attenua-

tion, the intensity of secondary electron flux would follow curve 1 and would reach a maximum at a depth P_m corresponding to the maximum range of the electron. Ionization would follow this same curve. After this point, exposure in an air-equivalent medium would be equal to ionization per cubic centimeter of air.

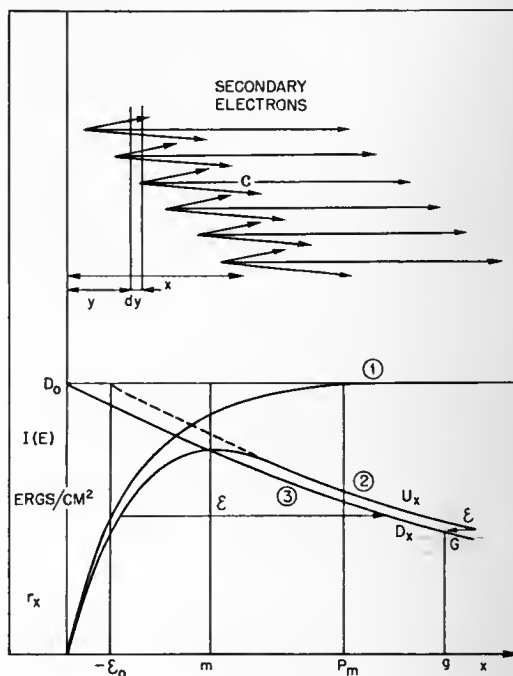

Fig. 1.

However, because of photon attenuation the ionization follows curve 2, and photon flux and exposure attenuate according to curve 3.

Let us consider a point located beyond the maximum. At this point the secondary electron flux and the ionization are higher than exposure because the electrons were set in motion in more superficial layers where the photon flux was higher. On the other hand, if we consider a point located more superficially, the exposure is greater here than ionization because the intensity of the flux of secondary electrons has not yet built up to its maximum value.

Calculations done by J. Dutreix (Ph.D. Thesis, Paris, 1956), assuming curve 2 as a sum of two exponentials, show that the maximum build-up point corresponds to the maximum of the ionization curve. This indicates that measurement of the exposure and use of the roentgen are possible at energies higher than 3 Mev.

Concerning chemical dosimetry I should like to say that the use of chemical measurement for absolute dosimetry is difficult, as Dr. Roberts pointed out. To pass from chemical reaction to absorbed energy, one must know the value of the so-called "G factor," which is estimated by measuring the energy necessary for one chemical reaction through ionization. At present, we find ourselves going round in a circle.

I would say just a word about clinical dosimetry. To estimate accurately a tumor dose, it is necessary (1) to calculate the dose distributed in homogeneous and heterogeneous phantoms; (2) to measure for every part of entry the surface dose in air and to check the dose, including scatter, at the skin or at some other position; and (3) to make sure that during all the treatments the positioning of the patient is always the same and that his immobilization is good. If the patient can move or if his position is not always the same, a factor of inaccuracy which is much greater than any other is introduced.

Friedman: Speaking on behalf, and I am presuming to do so, of the clinical radiotherapists, I want to thank the physicists for calling various features to our attention. The best way we can express our gratitude to them is to reciprocate.

The physicists have described their methods of measuring the roentgen and the rad. The only way we can corroborate this is by the crude device of observing and recording graphically the reactions of the normal mucosa and skin produced by stated doses. Unreliable as these observations may be, they, nevertheless, tell a rather striking story with respect to the absorbed dose of supervoltage radiation, and this story is not consonant with the proffered physical units.

For example, I think every radiotherapist in the room would agree that a skin dose of 8000 r over a period of five to seven weeks should consistently produce at least a second-degree skin reaction. Yet, when supervoltage rotation therapy for cancer of the mouth and cervical nodes is used, wherein the skin receives almost the same dose as the mucous membrane, second- or third-degree skin reaction is expected. Nevertheless, in a group of 50 patients, we have found in only 15 per cent of the cases a mild second-degree skin reaction from 8000 r, and in the other cases, a first-degree skin erythema.

The dosimetry at the Hospital for Joint Diseases, New York, is fairly accurate, Dr. Gerald Hine being the responsible physicist. Allowing for possible errors, there still remains the large discrepancy between exposure dose and absorbed dose, which the rad cannot explain.

No one has mentioned the relative biological effectiveness (RBE). In last December's Chicago symposium an excellent group of experimental papers suggested that the RBE derived from experiments on several biological test objects might be 0.8 or 0.7. Our own clinical observations to date suggest that the RBE for 2-Mv X rays is approximately 0.7. I shall conclude by restating the fact that the rad, though an improvement over the roentgen, does not explain the discrepancies we have observed; and, eager as I am to accept the rad as the ultimate unit of absorbed dose, I would prefer more substantiation.

Loevinger: Perhaps I might make a few comments on the words of each of the discussants. With the comments of Dr. Roberts I have no argument. He emphasized chemical dosimetry a bit more than I did, probably in part owing to his greater familiarity with

the method. No doubt he is correct in that ultimately the chemical methods of dosimetry will be of great importance.

With the remarks of Dr. Tubiana I am in agreement, with one small exception. If I understand him correctly, he uses the word "exposure" as being essentially equivalent to flux, which is energy per square centimeter per second, and he points out that the roentgen can be used as a reasonable measure of flux at all energies. Though I said nothing about flux, I was aware of this fact mentioned by Dr. Tubiana because not long ago I had the benefit of a discussion with one of his distinguished colleagues, Dr. Jean Dutreix. However, in radiological practice we are not interested in flux; the measurement of flux is essentially a problem for the physics laboratory. In radiology we are interested in dose to tissue and in those measurements that lead to information about dose to tissue.

Starting from flux information about a betatron beam, it is very difficult to go to meaningful information about locally absorbed energy in tissue. Thus I decided to ignore altogether the problem of flux in the time allotted to me. When I said that the roentgen should not be used above 3 Mev, I had reference to measurements that would be converted to absorbed tissue dose. I am still of the opinion that the roentgen is not a useful radiological unit at energies above 3 Mev.

There is more to be said about the semantics of the situation. It is my understanding that at Geneva a decision was made by the International Commission on Radiological Units, or some subdivision thereof, that the roentgen would be an expression of exposure and the rad would be an expression of dose. When a member of another international committee heard of this, he pointed out that the literature was full of dose in roentgens. Thus the decision would lead to much confusion and might even require the repeal of some official documents; such a situation is always a little embarrassing. Thus the decision was made that, for the present, we will talk of exposure dose in roentgens and absorbed dose in rads. Under circumstances where it does not make any difference which unit is meant, presumably one just talks of dose. However, if it is important to know whether the unit of dose is roentgens or rads, the appropriate adjective, "exposure" or "absorbed," must be included.

In reference to the comments of Dr. Friedman, I must say frankly that I disagree with the viewpoint expressed. First, I wish to apologize if my slides were not quite clear. Although I did mention RBE, I was talking primarily about linear energy transfer (LET) at the time. I wished merely to point out that, from physical considerations, it is not at all surprising that there is a difference between supervoltage and 220-kv radiation.

It seems to me that to use the word "roentgen" for supervoltages in an offhand way, based on experience with ordinary voltage, is somewhat reminiscent of a farmer who tries to compare the horsepower of his tractor with what his horses can do. There is a semantic confusion here in that the mere similarity of

the words leads one to expect a similarity in effect. The reason for introducing the rad into radiotherapy is that the nature of the distribution of absorbed energy is so different between supervoltage and conventional voltages that the roentgen loses its meaning. Thus glibly to carry the roentgen into the supervoltage energy region is a seeming simplification but an actual self-deception.

The rad is not to be considered as something that the physicists are trying to foist on the radiotherapists for the purpose of making things sound more scientific. Rather it should be viewed as an attempt to establish a rational basis for dosimetry that will apply in practice over a wide range of energies. To get the full advantage of this improvement in our concepts, we must reinterpret in rads the existing experience at ordinary voltages. This being done, there will be some rational basis for going on to the supervoltage region, where the same unit of dose will in fact be applicable.

*[Friedman: Dr. Loevinger differs with my viewpoint. I was not offering a viewpoint but presented some factual observations. These facts suggest that certain observed disparities are not explained by known physical considerations. Although the rad is an improved dosage unit, it clarifies only a portion of the clinical dosimetry problems accompanying the increased use of supervoltage radiation. I hope that subsequent discussions at this seminar will help us clinicians.]

Brucer: Both Dr. Friedman and Dr. Loevinger are suffering from a lack of training in pharmacology. The roentgen therapist is saying, "I have put two teaspoonfuls of sugar in the patient's hands." The rad physicist (Loevinger) is saying, "I have put two teaspoonfuls of sugar in the patient's mouth and saw him swallow it." Dr. Friedman is now bringing up an entirely different point and is saying, "Two teaspoonfuls of sugar swallowed by the patient does not inform us of the patient's metabolism of the sugar. We do not know whether the patient has sprue or diabetes or is just hungry." No simple physical unit such as the

roentgen, the rad, the calorie, or the gram does anything more than measure quantity. The RBE is the kind of unit that can be described only by picturing a pharmacologist observing his patients with a telescope. The LET is a unit that marks the conversion of a physicist to a biophysicist. Over 100 years ago pharmacognosists became pharmacologists when they graduated from high school chemistry to become biochemists. With the rad and the LET, radiotherapists might be approaching high school commencement.]

Chalmers: In this matter I have to be a realist. We have so many therapy machines that we must use the best available method of dosage measurements, the condenser ionization chamber. We would be prepared to use a calorimetric method; we would be quite prepared to use a chemical method. We have, in fact, tried a crystal-conduction counter. We have tried cadmium sulfide counters, but we have abandoned them because of their vast wave-length sensitivity at 6 to 1.

I, myself, have developed a new circuit for the diamond-conduction counter and have found it of use. Unfortunately, the diamonds that are available (and these were made available to us by the Diamond Producers Association of South Africa, who picked out the best crystal-conduction counter diamonds from a hundred thousand) still show signs of fatigue and saturation.

It is a pity because the diamond is almost ideal for atomic number C^6 . But, as to the present state of knowledge of crystal-conduction counters, we have to be realists. There may be better crystals than the diamond or cadmium sulfide for conduction counters.

Therefore, for the moment, I reiterate, we are using standard isodose curves and unit-density phantoms. We transform them to a heterogeneous phantom and make direct measurements in any body cavity wherever possible.

Tubiana: I want to answer Dr. Loevinger. I did not say that exposure was flux. I said that exposure was a way of characterizing flux. The roentgen has to be used as a unit of exposure and not, in any circumstances, as a unit of dose.

* These comments were made after the session had adjourned. The editor has inserted them here.

Section B

Dosimetry of Moving Fields

Howard B. Hunt
(presiding)

Limiting Factors of Moving-field Dosimetry

CHAPTER 5

J. Eric Roberts

Middlesex Hospital
London, England

Abstract

The major limitation in moving-field dosimetry lies in the complexity of the measurements or calculations required to determine a complete dose distribution. This arises from the fact that the dose rate at any point in the irradiated field varies with time in a complex manner, making analytical integration almost impossible.

It has been shown that, for a given beam area with radiation above 1 Mev, attenuation in tissues is very nearly exponential and a constant effective absorption coefficient for each field size can be found. This enables conventional isodose charts to be used to determine dose distributions in rotation therapy, allowance being made for the differences in tissue thickness traversed, by means of the absorption coefficients. A comprehensive scheme for dose-distribution estimation for full rotation and arcing is described, involving comparatively simple computations. In a further simplification the production of standard tables and curves makes possible the elimination of most of the detailed computation from individual treatment plans.

Methods of shaping isodose surfaces by simple physical means are briefly discussed.

Two or three matters of explanation are necessary. First, I make no claim whatever to being an authority on teletherapy or its rotational form. My contacts with the practice of rotational therapy are largely by remote control, and any figures or results I may produce in this talk are entirely due to my colleagues, D. E. A. Jones and C. Gregory at Mount Vernon Hospital, London. If there is any credit, they should have it.

One point, which is not in my notes, was mentioned by Dr. Hunt. Some 25 years ago, when I first went to the Royal Cancer Hospital in London, I was looking about for some bits of apparatus when I came across the spindle and part of a table top of what was obviously a rotational-therapy apparatus. It was, in fact, the original rotation apparatus for therapy used by Robert Knox some 20 years before that.

The title of this talk is not of my own choosing. It was presented to me by post, without comment or explanation, and I have to confess that I still have no clear idea of what was in the minds of the organizers

when they assigned me the title. Having unburdened myself of that confession, I take a look at the title, take it literally, and search for limiting factors in moving-field dosimetry. After all the searching, I can find only one, a big one. It is that in its most detailed form moving-field dosimetry is just too complex and too tedious for any ordinary radiotherapist or physicist. The problem of the physicist is to find some compromise system of dosimetry which will satisfy the needs of the radiotherapist and which, at the same time, will be capable of routine application in everyday work in the radiotherapy departments. Therefore, rather ignoring the official title of the talk, I shall deal with one of many attacks on this fundamental limitation of the complexity of rotation therapy.

The basic problem of radiotherapy remains the same, whether it is carried out by rotation, moving fields, or fixed beams. The radiotherapist determines a relatively inaccessible volume of tissue and prescribes a radiation dose—we should now say an absorbed dose—to which this volume must be subjected with the minimum irradiation of other tissues.

The physical problem is to determine the distribution of dose in and around the so-called "tumor volume" for the radiation technique used. With a fixed-beam treatment this is a comparatively simple matter. When a fixed beam is aimed at a tumor, any one point in the tissues accumulates dose at a fixed rate, and the integration up to the prescribed dose is simply a matter of multiplying the dose rate by the time of irradiation. The dose rate at any fixed point in tissue (neglecting minor variations due to anatomical constitution, geometry, etc.) can be determined in a tissue-equivalent phantom; we have been doing this for a long time. In multiple-field therapy the process may have to be repeated from two to six times, but there are no real computational difficulties that cannot be solved with a simple adding machine.

In any form of rotation therapy, from a physical point of view, at all points within the irradiated medium, the dose rate varies continuously, usually with

a very complex function of time, and any attempt to integrate analytically this dose rate up to the full-treatment dose is almost certainly impossible. The time function, if one can get that concept, of the variation of the dose rate at any point during a rota-

With that complexity in mind I shall outline a method tried at Mount Vernon Hospital for overcoming this fundamental limitation in rotation-therapy dosimetry. It is not the only solution; there are a dozen at least, each one more complex and more dif-

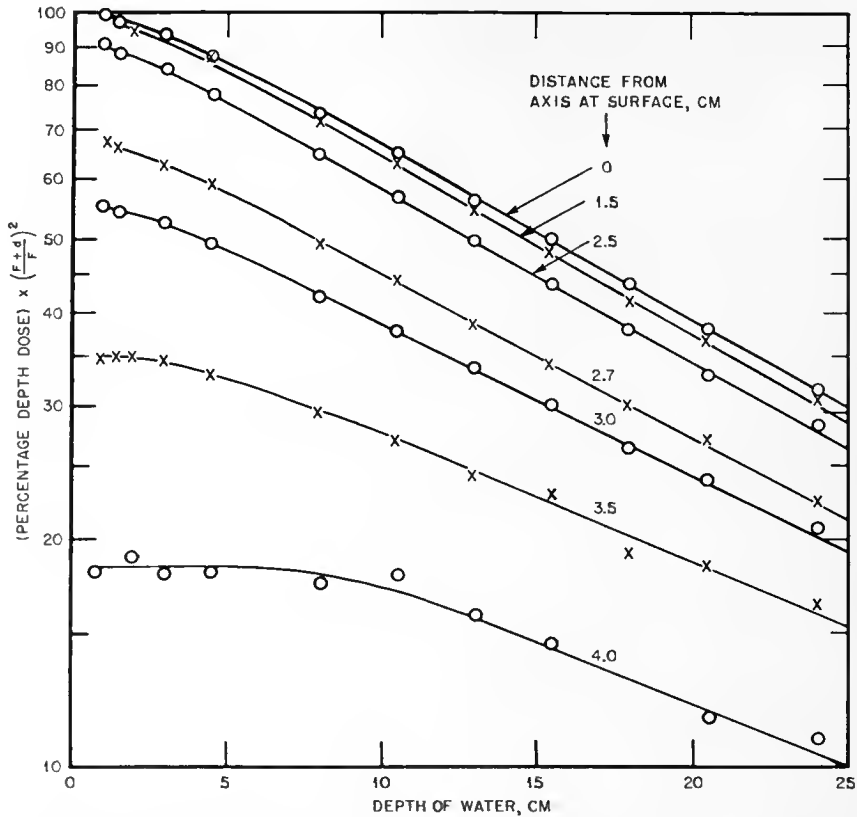

Fig. 1—Percentage depth dose, modified to eliminate inverse-square attenuation, plotted along the rays. Diaphragm, 3.2 by 3.2 cm; SSD, 60 cm; diaphragm-to-skin distance, 33 cm; field area at skin, 7.1 by 7.1 cm.

tional treatment depends on a large number of factors, the most important being the shape and size of the section of the body irradiated and the position and volume of the space of interest in relation to that body section.

We must therefore find a compromise for that impossible integration. We cannot find a simple, unique dose rate at a point, and thus the next best thing is to attempt to determine the dose received at the point in each cycle of rotation or oscillation. Again, for high accuracy this would require a complete integration over the periodic time of the rotation, but in practice we always use a step-by-step integration. An exception may be the method that Dr. Chalmers mentioned, which gives a possibility of a mechanical integration without steps. In some cases we can measure the dose per cycle at various points, at least in a phantom and sometimes in the patient's body cavities, but in routine practice this can be a very cumbersome method, especially if a full distribution is desired.

difficult than the last. We think this method has some advantages in its simplicity.

One of the first things a radiation physicist does when he is confronted with a new piece of radiotherapy equipment is to produce a set of isodose curves for fixed-beam conditions. No matter what is to happen to the apparatus afterwards, he starts there.

Most of the work I shall describe was done with a Theratron 1000-curie unit at Mount Vernon Hospital, although we now believe it is applicable, in general, to the 1- to 10-Mev photon energy range. Lower energies, below 1 Mev, introduce considerable complexities and limitations in rotation-dose estimation. With the Theratron we have produced conventional isodose curves for all the usual field sizes at 60 cm source-to-skin distance (SSD) (not source-to-rotation center) by using a water phantom. In rotation therapy the SSD varies continuously with the skin contour and the plane of rotation. With the Theratron, for example, at 75 cm radius of rotation, the SSD usually varies between 50 and 70 cm.

However, it would be a great advantage and a great simplification if we could derive rotational dose distributions from conventional isodose curves. Many attempts have been made to do this, some of them involving elaborate computations and some even depending on complicated calculating and accounting machines. We think now, as a result of the past two or three years' experience, that nature, rather than machines, can help a little in this matter. As is well known, for a narrow beam of radiation falling on a block of tissue, the dose at a depth d is given by

$$I_d = \frac{F^2}{(F + d)^2} e^{-\mu d}$$

where F is the SSD and μ (if there is a narrow beam) is an absorption coefficient. With wider beams, scattered radiation causes some change in this ratio, but with radiation above 1 Mev this effect of scattered radiation is comparatively small.

Figure 1 shows one consequence of this, and this is where I think nature helps. We take a source and a phantom and consider a series of radii coming out from the source into the tissue. We take points along these radii, multiply the dose at each point by $[(F + d)^2/F^2]$, and so eliminate the effect of the inverse-square law on this dose. In other words, we obtain a curve representing simple absorption of radiation along these lines without the inverse-square law. The result is a strange fact of nature. Apart from the first 2 or 3 cm of depth, all these semi-logarithmic plots are linear and, what is more interesting, nearly parallel. Therefore, from the slopes

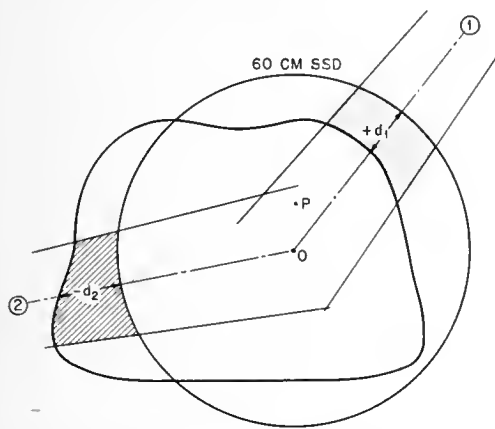

Fig. 2—Examples of tissue deficit d_1 and excess d_2 for two instantaneous positions of an isodose chart rotated around point 0.

of these curves, we can find an effective absorption coefficient that is applicable to any ray coming into the tissues. Similar sets of curves have been obtained for all other beam areas in use. In effect, for any given beam area out of the Theratron or any 1- or 2-Mev machine, there is a simple absorption that the physicist can use.

Having made the calculations for all the diaphragms in use, we have a value of μ , which we place on the side of every diaphragm for future application. For the benefit of the physicists, if we extrapolate the value of μ back to zero field (i.e., for very narrow beams), we get a μ of about 0.066, which is just about right for the true absorption of cobalt gamma rays in water. This constant value for an effective absorption coefficient in tissues with this particular type of radiation gives a clue to a simple method of assessing rotation dose.

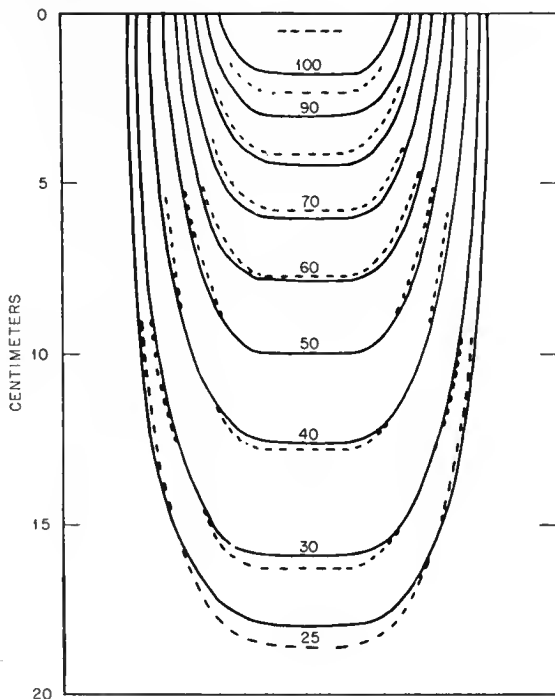

Fig. 3—Comparison between experimental and calculated isodose charts for 60 cm SSD. —, calculated by $\bar{\mu}$ method from experimental 50-cm SSD chart. ----, experimental 60-cm SSD chart.

Figure 2 illustrates the basic principle of the method applied to a body contour. The rotation center is 0, and the circle represents the 60-cm SSD, on which the isodose plot might be placed. Two instantaneous positions of the beam are shown as it is taken around the circle. From a beam placed in position 1, P will receive a higher dose than the chart shows because of the deficit of d_1 cm of tissue. From a beam in position 2, P will receive less than the isodose chart shows because there is excess tissue d_2 there. We can estimate these differences in the dose at P by multiplying the dose on the chart by a factor (which all radiotherapists hate) $e^{-\mu d_1}$ for beam 1 and $e^{-\mu d_2}$ for beam 2. Once we have that one simple figure μ , we can estimate from the conventional 60-cm SSD isodose charts the dose at any point in a phantom or body contour of any shape. It sounds complicated; in practice it is very simple.

Before we tried this in practice, we made a simple test. Using one particular diaphragm size, we prepared two sets of conventional isodose curves by

Returning to the rotation problem, we follow fairly conventional lines. We cannot do a full analytical integration, and therefore we divide the rotation

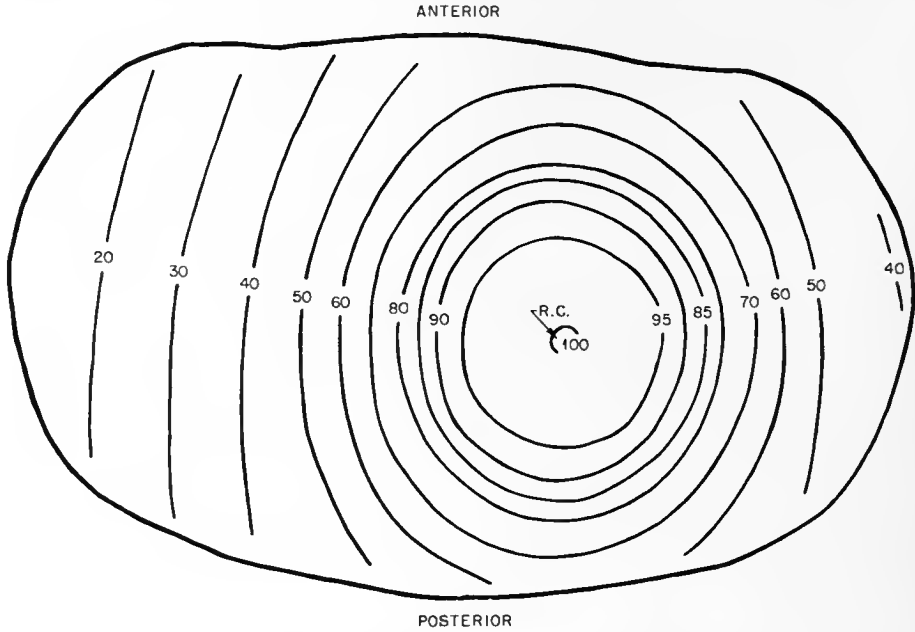

Fig. 4—Full-rotation dose distribution in rotation plane, showing virtually concentric isodoses with only slight displacement from the rotation center (R.C.).

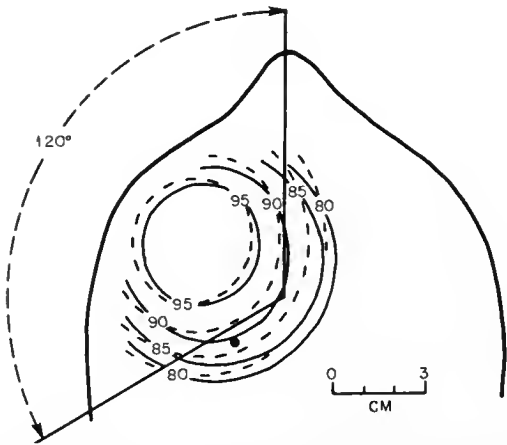

Fig. 5—Isodose distributions derived by the effective μ method, using 70- and 60-cm SSD charts. —, 70 cm SSD. ---, 60 cm SSD. Average SSD, 68.5 cm.

direct measurement in a phantom at 50 and 60 cm SSD. In Fig. 3, the broken curves are the experimental 60-cm SSD isodose curves. Then, from the 50-cm SSD isodose curves, we found a value of our effective absorption coefficient μ and calculated a set of 60-cm SSD isodose curves, using the 50-cm SSD curves as a basis. The unbroken curves in Fig. 3 are the ones we calculated from the "wrong" isodose curves. Apart from a few points near the surface and the bottom, agreement is reasonably good.

circle into 18 intervals of 20 deg each. That is, we use 18 fixed fields to simulate full rotation. The relative dose at any point in the field is given by the sum of 18 doses from 18 fields. This can be represented as

$$\sum_{i=1}^{18} p_i e^{-\mu d}$$

adding up for all fields, where p is the dose read from the standard 60-cm SSD isodose chart and d is

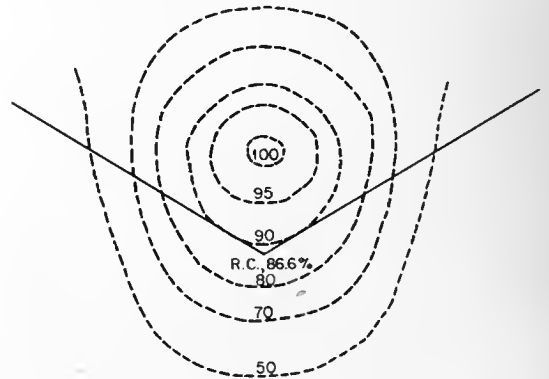

Fig. 6—Derived isodose distribution for 120-deg cycling, using 60-cm SSD charts. Fields are totaled at 20-deg intervals; diaphragm D produces a 7- by 7-cm field at 60 cm SSD; Theratron unit.

the tissue excess or deficit in that particular field. If we want a full dose distribution, we repeat this process for a large number of points in and around the treated volume and interpolate isodose curves. This sounds complicated in print, but, in fact, with previously prepared tables of $e^{\mu d}$, which any high-school boy could make, and a simple adding machine,

relevant points is integrated using the conventional 60-cm SSD isodose charts and the appropriate value of μ for the beam size used.

Figure 5 shows an example of arc therapy calculated in this way. This particular example was deliberately chosen as an extreme case for dose calculation; it is a tumor quite near the surface, and dose

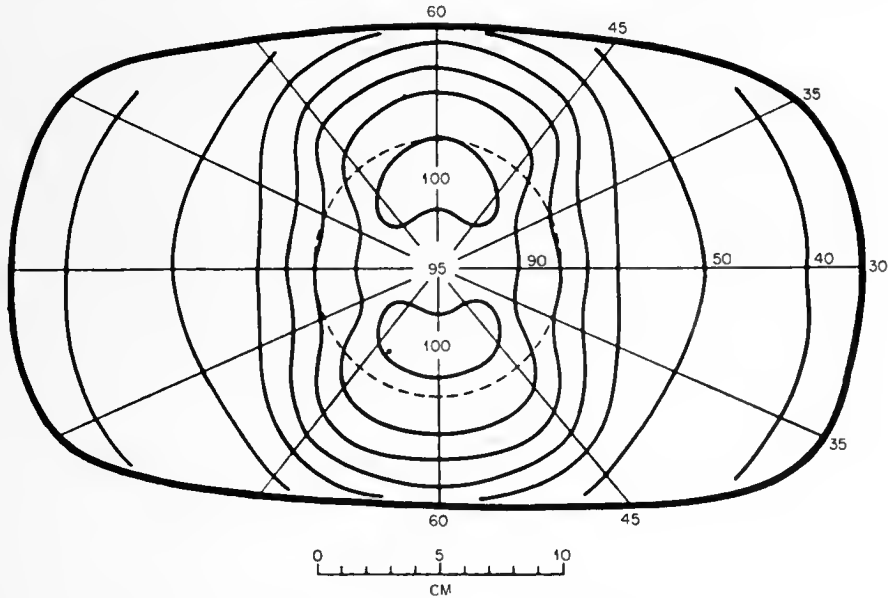

Fig. 7—Isodose (for 250-kv X rays) in homogeneous pelvic phantom, 360-deg rotation, centering in the middle width-of-axis field (---). The ratio of roentgen flux in the tumor to air (D_x/I) is 75.5 per cent.

we can obtain a distribution more than adequate for clinical use in 1 hr or so.

Figure 4 shows a typical full-rotation distribution produced in just this way. Here the rotation center was quite eccentric in the outline, and therefore there were large corrections for tissue excess and deficit from either side. The correction factor varied from $e^{\pm\mu d} = 0.84$ to $e^{\pm\mu d} = 0.139$. Nevertheless (and this is rather surprising), the isodose curves are very nearly circular, and the high dose point is quite near the rotation center in spite of the eccentric tumor and the roughly elliptical body.

Once we have this relative dose distribution, all that is required to fix the dose to the tumor is a measure of the dose per cycle at the rotation center. This can be done by measuring with an ionization chamber in the patient if a place for it can be found. Even if this is not possible, it can be calculated quite accurately from the average radius of the cross section of the patient, which leads to a knowledge of the average tissue deficit; then, from the known value of μ , the dose is estimated.

We can use the same principle exactly for arc therapy. This is used if the tumor volume is situated very eccentrically, cutting down the irradiation of healthy tissues. Again we divide the chosen arc into 20-deg sections, and the relative dose to all the

distribution should not have been calculated by this method. We made two estimates of the dose distribution by this method. One was made using the 60-cm SSD isodose charts, the arcing circle for this distance being shown in the figure. There was a big tissue deficit for all points in the tumor, which meant very large corrections. We did the same thing using 70-cm SSD isodose charts, which meant that the skin surface was traversed, the doses being given with little or no correction. As can be seen, there is very little difference between the two distributions. In fact, anywhere in the volume of interest the difference is never greater than 6 or 7 per cent, which is satisfactory to most people. Here again we get the absolute dose distribution by estimating or measuring the dose at the rotation center or at one point in the tumor.

Before considering some simplifications of this dosage system, it might be of interest to look at another general aspect (I do not think it is quite a limitation, at any rate for high energies) of the problem, which is fairly well known but not always seriously thought about, namely, the position and shape of the isodose distribution in rotation therapy.

Figure 6 illustrates the first well-known point, namely, that in arc therapy the region of maximum dose is always a good deal nearer the skin surface

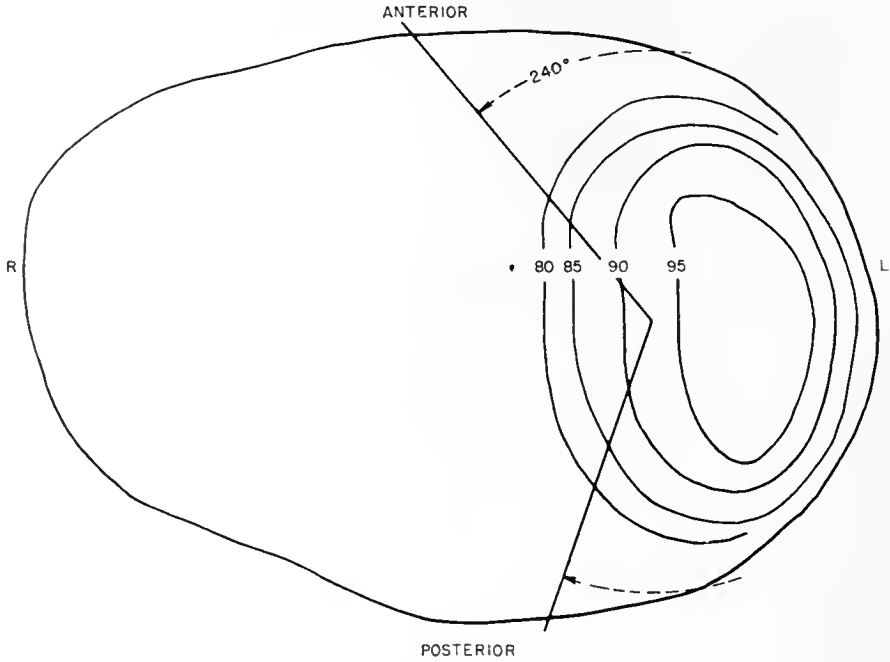

Fig. 8—Oscillation (240-deg arc) showing characteristic elongation of isodose contours.

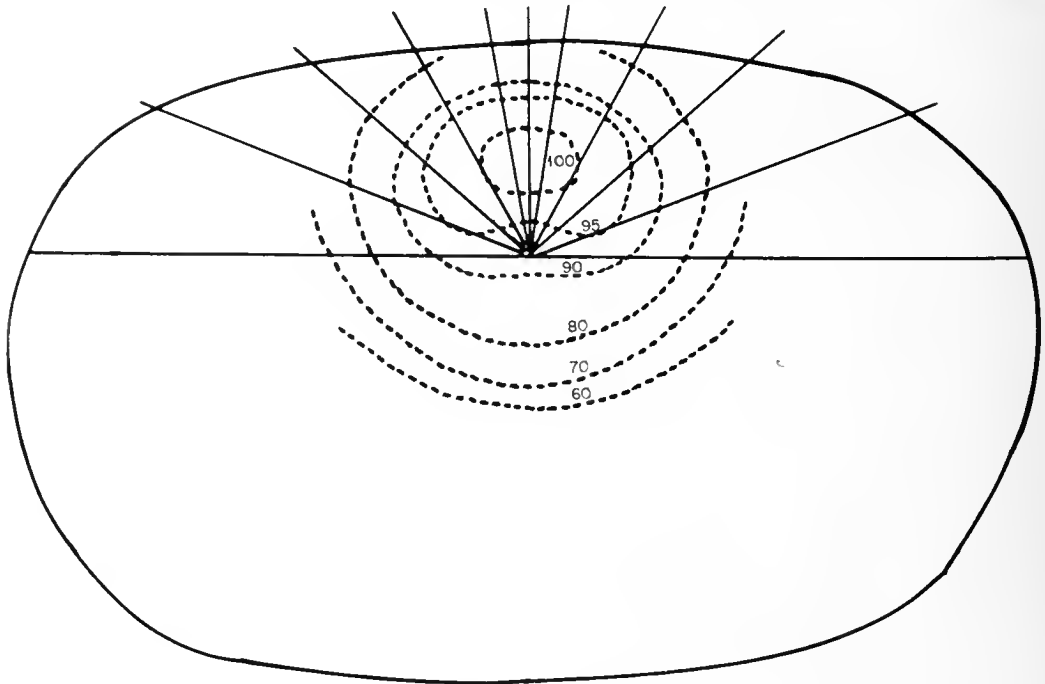

Fig. 9—Oscillation (180-deg arc) in the plane of the short axis for treatment of bladder lesion, showing elongation of isodose contours. Depth of the rotation center, 6.7 cm.

than the rotation center. We have had this situation with fixed-beam therapy for a long time. This displacement must depend clearly on a number of factors such as beam size, arcing angle, and tissue depth.

The other point concerns the shape of the main distribution, i.e., the shape within which we attempt to enclose the tumor volume. As we have seen in Figs. 4 and 5, with 360-deg rotation the isodose surfaces are effectively spherical and are more or less

independent of the body outline. In this we have an essential difference between the high-energy radiations (1 Mev and upward) and conventional 250-kv X rays. With 250-kv X rays, owing to higher absorption effects, a full rotation around the pelvis or chest produces an isodose system elongated along the short axis of the body contour. Figure 7 is an example of this, taken at random from the comprehensive work of Howard Nielsen on this subject. In some circumstances, e.g., in irradiating a pelvis, this can be quite a nuisance, and in such a case there is no simple correction for it other than uneconomical lateral arcing. Arc therapy with high-energy radiations provides an interesting exercise in isodose volume shaping by simple physical means.

An arc of about 120 deg with high-energy radiations produces, perhaps rather surprisingly, an almost spherical isodose distribution, with a considerable displacement of the high dose point toward the skin surface, as in Fig. 5 for irradiation of the antrum. As the arc is increased above 120 deg to about 270 deg, the main isodose system becomes elongated in the direction at right angles to the line bisecting the arc. Figure 8 illustrates this for a 240-deg arc. This unknown patient has a rather peculiar body contour and a lesion in a somewhat surprising position, which makes me think that it is probably a figment of some physicist's imagination. Figure 9 shows an actual case selected at random from our records, with 180-deg rotation, giving a slightly elongated distribution for a bladder irradiation. In some circumstances such a large arc might be undesirable on clinical or physical grounds. The same effect can fortunately be produced by using a smaller arc, irradiating less tissue and cutting out an appropriate section of the middle of the arc by switching off the radiation beam, as can be done with many machines nowadays. One example of this is given in Fig. 10, which shows a nasopharyngeal fibroma treated with 140-deg arcing, but with 60 deg in the middle of the arc cut out by switching off the beam. In this way a very elongated distribution is obtained by simple physical means.

With angles less than 120 deg, the complementary effect occurs, and there is a tendency, though not very pronounced, to elongation along the line bisecting the arc. Figure 11 shows this effect, where we have 100-deg arcing and some elongation along the line bisecting the arc. Thus with a little practice and study it is possible, without using elaborate equipment, to produce isodose surfaces of almost any shape which could fulfill the requirements of the most exacting radiotherapist. This is a subject that might well deserve some further thought.

Now I shall return to the general problem because I know I have given an impression of complexity in this calculation of dose distributions. From our recent experience there seems to be a possibility of further simplification. As we have seen already, the low and almost constant effective absorption coefficient for hard gamma rays leads to a comparatively simple method of assessing dose distributions, in

both full and arc rotations, and also to that rather surprising circular symmetry of the distribution for full rotation. We now find that the relative dose distribution (i.e., the percentage dose distribution referred to the rotation center as 100 per cent) is, to a large extent, independent of the shape and size of the body contour. This applies, within useful limits, to both full-rotation and arcing conditions. It is a little surprising but it seems to offer possibilities.

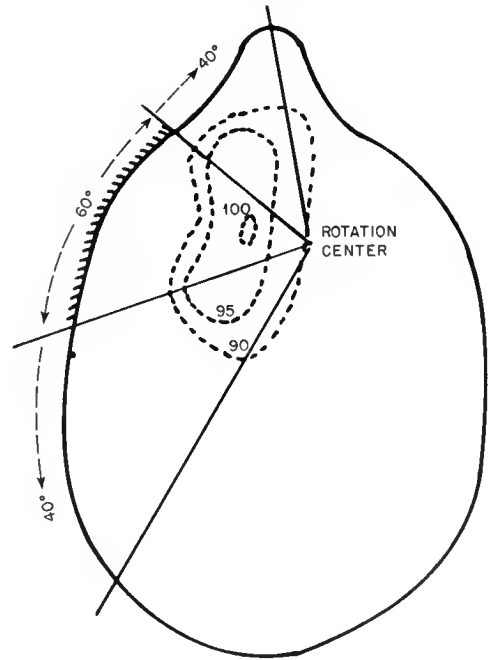

Fig. 10—Isodose distribution in irradiation of a nasopharyngeal fibroma with a Theratron. The total arc is 140 deg. The shutter is closed for the central 60-deg arc, resulting in an elongated irradiated volume (oscillation, 100-deg arc). The elongation is along the line bisecting the arc. Diaphragm, 6 by 9 cm; long axis rotating; transverse section, $2\frac{1}{2}$ cm below infraorbital margin.

Perhaps I can illustrate this simplification by describing briefly the method for a full 360-deg rotation. For practical purposes we now forget the outline of the patient altogether. We treat the patient as a 15-cm-radius cylinder. This is divided into 18 sections, 20 deg apart, the radii being numbered 1 to 18, and, starting from the rotation center 0, points A, B, C, D, etc., are marked 1 cm apart (Fig. 12). For a given beam area the conventional 60-cm SSD isodose chart is placed in turn on radii 1 to 18, and the doses at points A, B, C, etc., are read and tabulated. Figures for one particular beam diaphragm of the Theratron are shown in Table 1. The doses at each radial point are totaled and converted into percentages of the dose at the rotation center. From these percentages we can produce what is, in effect, an inverted percentage depth-dose curve for the radius, with 100 per cent at the center, falling off to the periphery. This is shown in Fig. 13. Since the

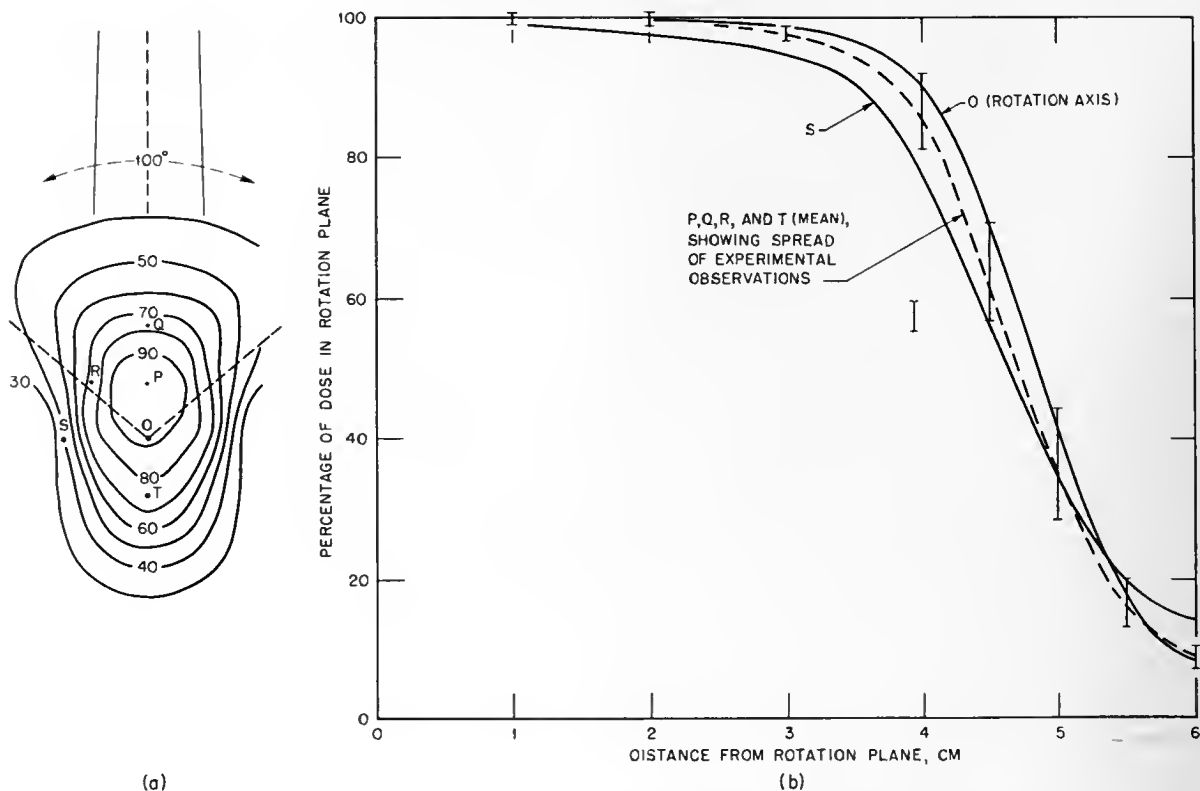

Fig. 11—Co⁶⁰ gamma-ray dose distribution in plane of rotation with a 100-deg arc, showing the elongation along the line bisecting the arc. (a) Field, 9 by 4.5 cm; O, rotation center. (b) Relative dose distributions through P, Q, R, S, and T, parallel to the rotation axis.

Table 1—SUMMATION TABLE FOR A 360-DEG ROTATION DOSE CALCULATION FOR A 10- BY 15-CM FIELD*

Field No.	A	B	C	D	E	F	G	H	I	Rotation center
1	38	42	45	46	53	56	60	65	70	36
2	36	42	44	47	51	54	56	60	60	36
3	37	40	42	43	42	40	34	27	14	36
4	37	36	36	37	31	22	16	8		36
5	37	37	34	30	23	16	10			36
6	35	34	33	26	21	16	10			36
7	34	33	31	27	23	18	15	6		36
8	34	32	30	26	24	21	18	16	11	36
9	33	31	28	27	25	23	21	19	17	36
10	33	30	26	26	24	22	20	16	17	36
11	33	31	26	27	25	23	21	19	17	36
12	34	32	30	26	24	21	16	16	11	36
13	34	33	31	27	23	18	15	6		36
14	35	34	33	28	21	16	10			36
15	37	37	34	30	23	16	10			36
16	37	36	38	37	31	22	16	8		36
17	37	40	42	43	42	40	34	27	14	36
18	36	42	44	47	51	54	56	60	60	36
Total	641	646	633	606	557	468	440	359	291	648
Percentage	99	99.6	97.5	94	86	75.5	66	55.5	45	100

*Short axis rotating 18 fields at 20-deg intervals; diaphragm-to-skin distance, 33 cm; portal, 10 cm.

whole system is symmetrical, the same curve applies to the doses on all the 18 radii, and thus by interpolation we can produce a set of isodose curves

that will be in the form of circles. We have found that, within the normal limits of clinical practice, relative dose distribution is almost independent of body contour. The important thing about these curves is that, once they have been produced for a given beam aperture, the same set of relative dose curves can be used for practically any patient under normal circumstances. In applying the curves to the treatment of a patient by using this beam aperture, it is necessary only to measure or to estimate the dose delivered to the rotation center or to some other point to obtain the absolute dose distribution throughout the treated area. In practice a few days' work will provide relative dose distributions for full rotation with all the beam apertures normally used. After this the planning of an individual treatment involves only the choice of the appropriate chart and the measurement or calculation of a single dose rate.

Figure 14 shows an interesting illustration of the process. We made up an imaginary patient with a 15-cm radius in one half of the body and a 10-cm radius in the other. The unbroken lines show the standard isodose distribution from the 15-cm-radius phantom; whereas the broken lines were produced by the longer method, allowing for the tissue deficit. It can be seen that the two sets of curves are very nearly coincidental, indicating that, within quite wide limits, we can really forget the shape of the patient.

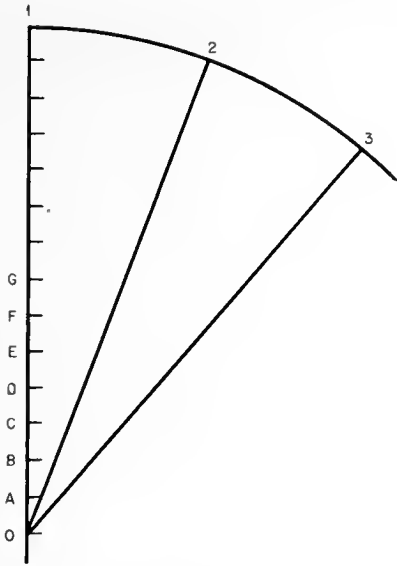

Fig. 12—Radii on a 15-cm-radius phantom.

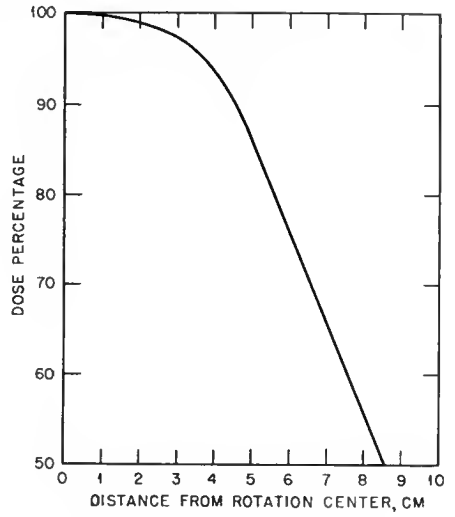

Fig. 13—Summation of 18 fields around a 15-cm-radius cylindrical phantom, using 60-cm SSD isodose curves; 360-deg rotation; 10- by 15-cm field; short axis rotating; Theratron unit.

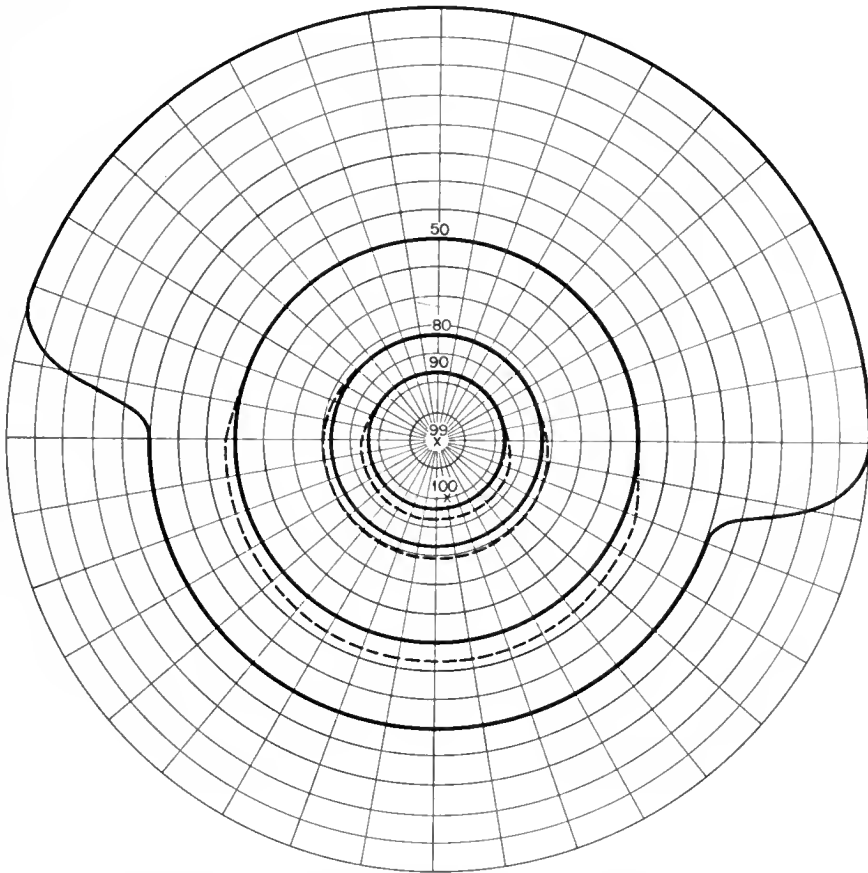

Fig. 14—Calculated isodose distribution (360-deg rotation). The diagram illustrates a composite cylindrical phantom wherein the upper half of the diagram is related to a cylinder of 15 cm radius and the lower half is 10 cm radius. The irradiation field is 7.5 by 15 cm. The distribution shows a slight distortion of the isodose curves due to 5 cm of absent tissue on the lower side.

Although not quite so simple, a similar standardizing process can be developed for arc therapy. I propose only to outline it very briefly here because it will be published in detail in due course by my colleague, C. Gregory. Figure 15 illustrates part of

radii, normalized to 100 per cent at the rotation center; from these curves the full isodose distribution can be determined. Although all the figures for the estimation of the point doses are available for a given beam area in Table 1, much time is eventually saved by tabulating relevant sums such as $\Sigma(1 \dots 6)$, $\Sigma(4 \dots 9)$, etc. Part of such a tabulation for the 10- by 15-cm beam area is given in Table 2.

The whole process, though somewhat tedious, is in practice less so than it appears in writing. Once the summation tables for all the beam sizes in use have been produced, a complete isodose distribution for any arc treatment can be determined in 2 hr or so. What is perhaps even more important is that, because distribution is almost independent of body shape, once the isodoses for, say, a 120-deg arcing treatment with a 10- by 15-cm beam have been produced, they can be used for any other patient, within wide limits, treated under similar conditions. We are accumulating a collection of sets of isodose curves of this kind for various beam apertures and arcing angles. Eventually it should be possible to eliminate

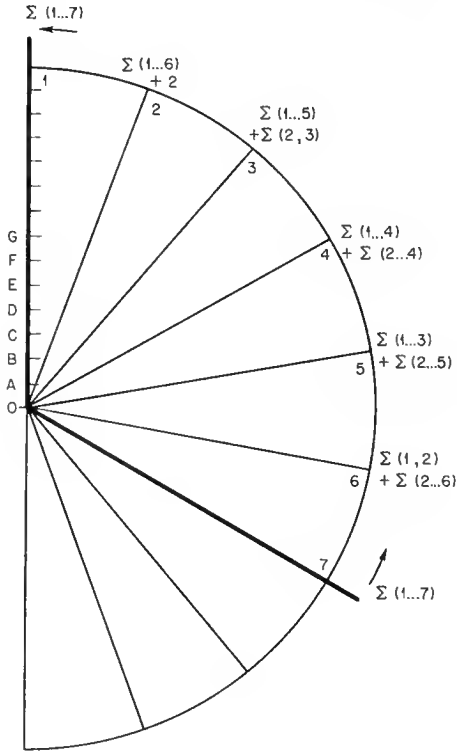

Fig. 15—Examples of summation for arc therapy.

the process for a 120-deg arc. Radius 1 is shown marked off in centimeter points 0, A, B, C, etc. In the full-rotation case the contributions to the dose at the points from all 18 beams, i.e., $\Sigma(1 \dots 18)$, are estimated, and the dose distribution along the radius is determined. Since the system is then symmetrical, no further computation is necessary (the radii being identical), and the isodose curves can be drawn out. In the arcing case (Fig. 15) the contributions to the dose at points A, B, C, etc., on radius 1 come from beams 1 to 7 and can be determined from Table 1, $\Sigma(1 \dots 7)$. Distributions along all the other radii must also be determined individually. Thus the summation for points on radius 3 is $\Sigma(1 \dots 5) + \Sigma(2,3)$, as shown in Fig. 15, and for radius 12 (not shown) it is $\Sigma(6 \dots 10) + \Sigma(8,9)$. The result of these computations is a series of 18 depth-dose curves for the

Table 2—EXAMPLES OF SUMMATIONS FOR ARC THERAPY*

	A	B	C	D	E	F	G	H	I
$\Sigma(1,2)$	76	84	89	95	104	110	118	125	130
$\Sigma(1 \dots 3)$	113	124	131	138	146	150	150	152	144
$\Sigma(1 \dots 4)$	150	162	169	175	177	172	166	160	144
$\Sigma(1 \dots 5)$	187	199	203	205	200	188	176	160	144
$\Sigma(1 \dots 6)$	222	233	236	233	221	204	188	160	144
$\Sigma(1 \dots 7)$	256	266	267	260	244	222	201	188	144
$\Sigma(1 \dots 8)$	290	298	297	288	268	243	219	184	155
$\Sigma(1 \dots 9)$	323	329	325	315	293	266	240	203	172
$\Sigma(1 \dots 10)$	356	359	353	341	317	288	260	221	189
$\Sigma(2,3)$	75	82	86	90	93	94	90	87	74
$\Sigma(2 \dots 4)$	112	120	124	127	124	118	106	95	74
$\Sigma(2 \dots 5)$	149	157	158	157	147	132	116	95	74
$\Sigma(2 \dots 6)$	184	191	191	185	168	148	126	95	74
$\Sigma(2 \dots 7)$	218	224	222	212	191	188	141	103	74
$\Sigma(2 \dots 8)$	252	256	252	240	215	187	159	119	85
$\Sigma(2 \dots 9)$	285	287	280	267	240	210	180	138	102
$\Sigma(2 \dots 10)$	318	317	308	293	264	232	200	156	119

* Derived from Table 1.

a great deal of computation in the planning of individual treatments by choosing the appropriate isodose distribution from the file and making a single dose measurement or calculation. To a physicist or radiologist burdened with much physical treatment planning, this might be an attractive prospect.

I fear I have strayed rather a long way from the subject of limitations of moving-field dosimetry. My only plea is that, if there are limitations, they are there to be overcome, and that is what we have tried to do in the field of dose computations.

Classical Isodose Curves for Moving Fields

CHAPTER 6

Fearghus O'Foghludha

Physics Department
Saint Luke's Hospital*
Dublin, Ireland

Introduction

We are fortunate at Saint Luke's Hospital, Dublin, in having had access to the first commercial models of both the Siemens-Reiniger convergent-beam apparatus and the Müller TU-I rotation machine. I understand that both have since been improved, and therefore the half-value layers (HVL) and other data I shall quote do not necessarily apply to the more recent models. A great deal has been written on the clinical results obtained, and I shall therefore limit my remarks to dosimetry problems and to the operation of the machines themselves.

Siemens-Reiniger Convergent-beam Apparatus

In this machine the X-ray tube follows a spiral tract that is part of a spherical surface. The beam is always directed at the center of the sphere, and, if the tumor is placed at, or near, that point, it will receive a very high dose. Meanwhile the beam sweeps out an extended spiral path on the surface of the skin, and therefore the skin dose per unit area is small.

In our machine the radius of the sphere is 45 cm, and the opening angle of the full conical pattern is 72 deg (Fig. 1). A complete cycle takes 6 min, during which the tube describes 27 turns of the spiral. In normal operation the HVL is slightly more than 1 mm of copper, and the tube output (in air) is 850 rhm, corresponding with 70 r/min at the center of the sphere. Circular fields are used, and their size is fixed by interchangeable stops ranging from 2 to 10 cm in diameter. The smaller fields give enormous depth doses, but in a very limited volume. With larger fields the high-dose volume can accommodate larger tumors, but volume is added at the expense of depth dose. In practice a compromise is struck by using a field that is small enough to give an advantageous depth dose yet big enough to distribute the high dose

over a reasonable volume. In addition to the field stops, applicators are provided by means of which the depth of the sphere center below the surface of the skin can be varied; compression can also be applied. The point of maximum dose always lies above the center of the sphere, and its position with a given applicator depends on the field size. It is therefore necessary to have isodose curves for every proposed combination of field stop and applicator.

The three-dimensional isodose surface obtained by rotation about the axis AA' shown in Fig. 2 is a typical isodose pattern. It resembles a pear with the broad end nearer the skin; the most striking thing about it is the high central dose. Furthermore, the high dose is confined almost entirely to the region between the center of rotation and the skin; the dose deep to the central point is very small, and this considerably reduces the integral dose.

The curves can be produced by calculation or by measurement. Calculation is too involved for day-to-day radiotherapy, and, in any event, the correspondence between clinical reality and the conditions assumed in calculation is too sketchy to warrant the labor. Calculation is difficult because the focal-to-skin distance (FSD) changes as the tube revolves. This causes inverse-square variation, alteration in the surface field area and back-scatter, change of percentage depth dose, etc. It would nevertheless be possible, though tedious, to take account of these variations, as is done in long-axis calculations, if it were not for the added complication that the angle of incidence changes during the cycle. It has been suggested that a hemispherical cap of tissuelike material be placed on the patient's skin to ensure normal incidence at all points in the cycle. This greatly simplifies the calculations; but we have not used this approach, and we measure each isodose pattern as required. Siemens-Reiniger supply an accurate set of (measured) isodose curves for a large number of setups (an ingenious system of factors permits allowance for variations in cycle time and tube output), but

* Operated by the Cancer Association of Ireland.

we cannot use them because our machine no longer duplicates the conditions (number of revolutions, HVL, etc.) used by Siemens-Reiniger in preparing their curves.

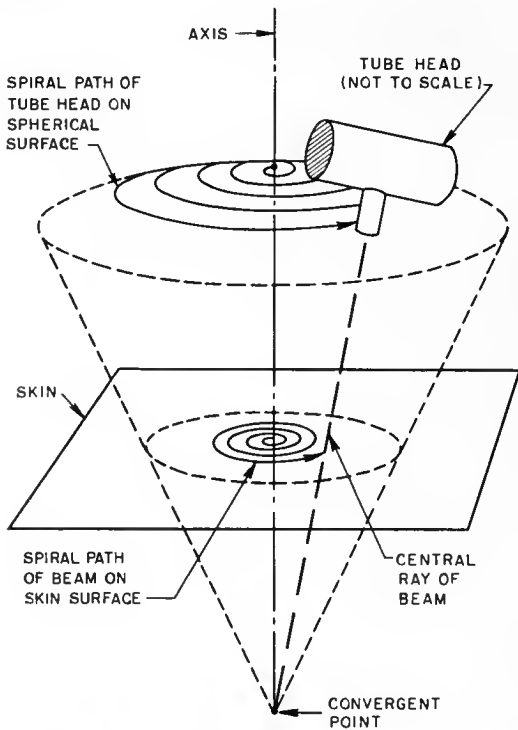

Fig. 1—Diagram of Siemens-Reiniger convergent-beam machine.

For measurement we use a multislab Mix D phantom and Baldwin-Farmer chambers; the procedure is conventional. I want to emphasize, however, that the measurements are laborious because it no longer suffices, as in stationary therapy, to measure the dose rate at a number of points in the phantom. Instead, the dose rate at each point must be integrated over an entire cycle. If measurements are made at several points simultaneously, the array of chambers may upset the radiation distribution, and, if only a few points are selected, many time-consuming runs are required. Siemens-Reiniger, for example, measures the dose at one point per cycle, and measurement alone takes 10 hr per setup. In a busy department a machine cannot be taken out of service for that length of time. Lest I give the impression that production of isodose curves is a serious obstacle to operation of these machines, I must point out that, once measured, calculated, or purchased, the isodose curves can be used again and again, and they are equally satisfactory for all patients because the body cross section affects the isodose pattern very little.

One novel aspect of dosimetry must be mentioned. If the dose distribution corresponding to one of the isodose curves is to be reproduced in a patient, during treatment we must duplicate the conditions (number of revolutions, HVL, applicator, and field-stop) which obtained during preparation of the isodose curve.

The actual dose (not to be confused with the percentage depth dose) delivered by this procedure may, however, be clinically unacceptable, although the shape of the isodoses is quite satisfactory. Although the actual dose is sensitive to all the factors mentioned, it is not permissible to change any of them to get the desired actual dose because doing so would alter the shape of the curves. The only factors that can be adjusted without affecting the shape of the distribution are the tube speed and output. In the Siemens-Reiniger machine the speed is fixed, but the tube output can be easily adjusted to give an acceptable actual dose and a desirable isodose pattern at the same time; if an isotopic source were used, a variable speed would be necessary. An ideal design is fairly easy to achieve in convergent-beam machines using fixed multiple isotopic sources, but the problem would be more difficult in a true moving-beam machine. Variation of dose rate rather than of irradiation time introduces no new principle, but it is sufficiently unusual to merit careful attention in the planning of high-energy convergent-beam machines.

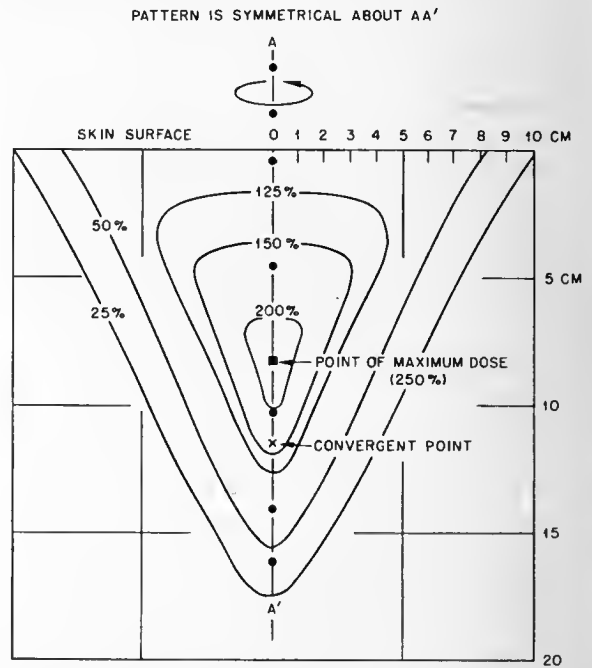

Fig. 2—Sketch of isodose distribution produced by Siemens-Reiniger convergent-beam machine. Percentage values marked on the isodoses refer to a dose of 100 per cent on the skin. The curves shown here approximate results obtained with a 4-cm field stop and an applicator that places the convergent point 11.5 cm below the skin.

We have had some electrical and mechanical troubles, but it is wrong to suppose that these troubles are inherent in the convergent-beam technique or in the Siemens-Reiniger apparatus. It is in fact a tribute to the value of the machine that, rather than lose treatment time by taking it out of service for overhaul, we have been able to allow unimportant mechanical faults to go uncorrected.

The greatest drawback is the low HVL. The technique is especially useful for delivering a high dose to a small volume that lies at no great depth below the skin. This suggests its use in the treatment, for example, of spinal metastases and tumors of the head

greater when the machine was new), and this is enough to accommodate patients of reasonable size; the distance between the X-ray focus and the axis, which we shall call the radius of rotation, is 50 cm and cannot be altered.

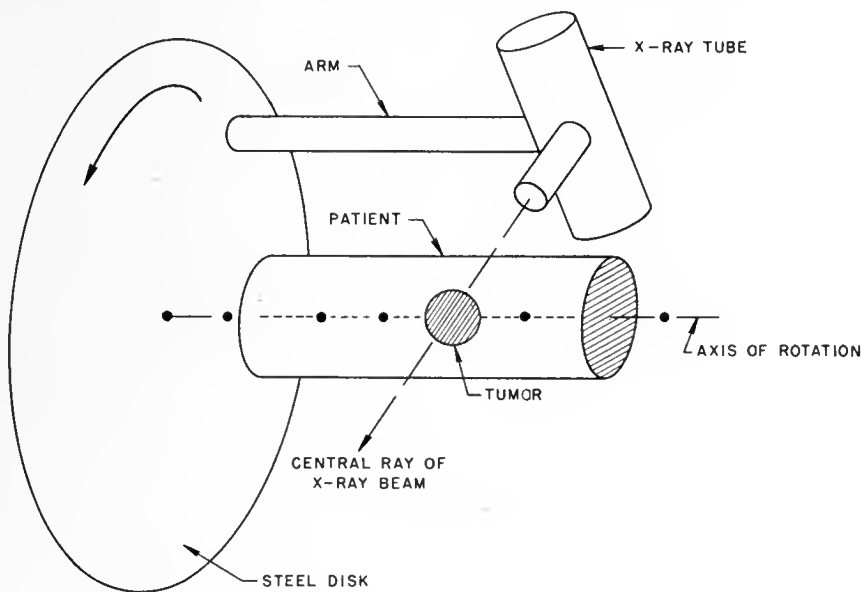

Fig. 3—Diagram of the Müller TU-1 machine.

and neck, but these are precisely the cases in which a low HVL is most disadvantageous because of the bony tissue present. Presence of bone introduces an unknown departure from the radiation distributions measured in a water-equivalent phantom, and whatever departure there is, known or unknown, is to the disadvantage of the bony tissue because of preferential energy absorption. Whether substitution of a medium-energy or high-energy isotope source is feasible and whether it is of advantage if feasible are questions that await further study.

Müller TU-1 Machine

This machine consists essentially of a large steel disk that carries a sturdy arm at a point near its rim (Fig. 3). A 200-kv X-ray tube (HVL, 1.5 mm of copper) is mounted on the end of the arm and is so disposed that the X-ray beam passes, at any chosen angle, through an axis that meets the center of the disk and is perpendicular to its plane. The disk can revolve so that the X-ray tube describes a circular arc about this axis. The arc is adjustable up to a maximum of 330 deg, but the speed of revolution is fixed at 1 rpm. The tumor is placed at the point where the X-ray beam intersects the axis of rotation, and consequently a high dose is delivered to the tumor but the skin dose remains comparatively small. The patient is usually placed so that his long axis is parallel to the axis of rotation. Clearance between the axis and the part of the tube closest to it is 22 cm (the clearance was

As in the convergent-beam machine, the FSD changes when the tube rotates about the patient, and calculation of the dose within the body is tedious by ordinary methods. J. E. O'Connor, chief physicist at Saint Luke's Hospital, has built a simple calculating machine that solves the problem ingeniously. I cannot improve on his elegant description of it in the *British Journal of Radiology*,¹ but, for those who have not seen his papers, I shall give a condensed account of the principles involved.

Dr. O'Connor deals with the actual dose rate rather than with the percentage depth dose. He first considers a beam of the required cross section and calculates the air dose at a large number of points within it for normal tube operating conditions. The skin dose at each of these points is then calculated. To do this, the surface back-scatter factors, elongation factors, etc., must be known for a variety of FSD's; but fortunately the energy region around 1.5 mm of copper is rather well documented, and the required information is easily found by interpolation in existing tables. The dose rates in roentgens per minute at several different depths below the skin are next calculated for each skin position. In this way the dose rate at the skin or at any point below it is known for all likely positions of the skin. The procedure is repeated for every beam size proposed for use. The calculations are not so tedious as they sound, and they can be completed by one man in the space of a few days. Calculations made in Dublin (for an HVL of 1.5 mm of copper only) are available to interested persons.

The calculated results allow one to find the dose rate at any point in the body cross section, but it then is necessary to tabulate them in a convenient way.

The quantity finally sought is the total dose to a given point, and this depends not only on the dose rate but also on the length of time for which the point experiences it. Since the dose rate changes during rotation, some means must be found of integrating it over the whole exposure. One possibility is to use the well-known wheel-and-disk integrator. The number of revolutions made by the wheel depends on the product of the angle turned and the distance of the wheel from the center of the disk. If the latter distance is made proportional to a given dose rate and if the disk is then rotated through an angle proportional to the time for which the dose rate exists, the number of revolutions made by the wheel will be proportional to the product of dose rate and time, i.e., to total dose. The angular velocity of the beam is constant, and the time for which a point is exposed to a given dose rate is proportional to the angular interval during which the dose rate is constant. This makes possible what I think is the most ingenious feature of Dr. O'Connor's machine: the lucite disk carrying the body section is also part of the integrator.

A complete isodose distribution can be plotted in a very short time.

Scattered radiation outside the main beam (at an HVL of 1.5 mm of copper) is appreciable and can be the principal agent in delivering dose to certain points in the body section. By assuming that the scatter dose is proportional to the primary dose at the skin or by using more subtle arguments that he has since developed, Dr. O'Connor calculates the scatter dose rate for a variety of body positions. Values are read and entered on the integrator. In this way effects of scattered radiation are quickly taken into account. The machine is much more difficult to describe than to use, and its main advantages, apart from speed and accuracy, are simplicity of construction and the facility with which an unskilled person can use it after a little practice.

A very attractive feature is that non-water-equivalent tissue can be allowed for easily. The effective thickness (in centimeters of water) is determined by the Newmann-Wachsmann method for several angular positions of the beam. The effective thickness in each position is assumed to lie along the beam and to be equally distributed about the center of rotation. Dr. O'Connor uses less naive assumptions, but the present one will serve for illustration. An effective body cross section is drawn on the lucite disk, and a calculation is carried out with the effective, rather than the true, cross section. In cases where it has been possible to compare calculation with experiment, the agreement is amazingly good even in bodies of complex constitution.

The machine will function equally well for super-voltage and gamma-ray installations; in fact, its application should be easier at the higher energies because scatter outside the beam is considerably reduced.

Integral Dose in Rotation Therapy

We have seen that the isodose distribution in complex rotational patterns can be calculated or measured with quite a high degree of accuracy. What then of integral dose? It is true that, when the isodose distribution is known in its entirety, the integral dose can be obtained from it, but the method is too laborious for everyday use. It is interesting to inquire whether a method exists by which we could calculate the integral dose in a few minutes, even if only approximately. R. L. Hayes of the Oak Ridge Institute of Nuclear Studies has developed an excellent system (based on experiments) by which the integral dose in any setup can be calculated from graphs in a matter of minutes; the following simple theoretical considerations show that the behavior of integral dose should be uncomplicated enough to allow description by a simple factorial system such as Dr. Hayes uses.

The first point worth recalling is that the integral dose imparted to a cylinder in delivering a given dose to a point on its axis is the same whether the field is moving or stationary, provided the axis of rotation and the cylinder axis coincide. This case at first sight appears trivial, but it allows us to see how the cylinder radius, field size, and FSD affect the integral dose and to compare the integral dose at different energies for the same tumor dose. The cylinder, of course, must be homogeneous.

In practical radiotherapy the patient is not usually cylindrical, nor is the center of rotation on the axis. In order not to make things too complicated, we shall deal with only one of these difficulties at a time. Let the patient be cylindrical and let the center of rotation be at a distance h from the cylinder axis. The FSD and the other factors mentioned before change as the tube revolves, and each of them affects the integral dose. Several people (notably Brückmooser and Keller) have, however, pointed out that the integral dose at 200 kv to a certain depth in a beam of fixed solid angle is independent of the FSD. If this is true, the integral dose during eccentric rotation about a cylinder should depend principally on the time of irradiation and should be independent of variations in the FSD.

When the integral doses given by the conventional expressions (Mayneord, Ellis, Wachsmann, Happey) are examined, it is found that the statement of Brückmooser and Keller should be correct within wide limits, not only at 200 kv but up to very much higher energies. Mayneord's expression, for example, gives the integral dose to a depth d in a block of tissue (Fig. 4) irradiated at FSD f cm, as the product of three factors:

$$\sum_d = DA \frac{1 - e^{-\mu d}}{\mu} \Delta \quad (1)$$

where A is the field area on the skin and μ is a quantity similar to, but not identical with, the one mentioned by Professor Roberts. D is the dose to the skin, and Δ is a factor that involves both μ and f . If f is altered, all three terms in Eq. 1 change. DA is the prod-

uct of skin dose and field area, and it remains practically constant. The reason it does so is that it can be expressed in the form

$$AD = AP [1 + S(A)] \tag{2}$$

where P is the primary dose and S(A) is the fractional surface back-scatter for area A. Both P and A

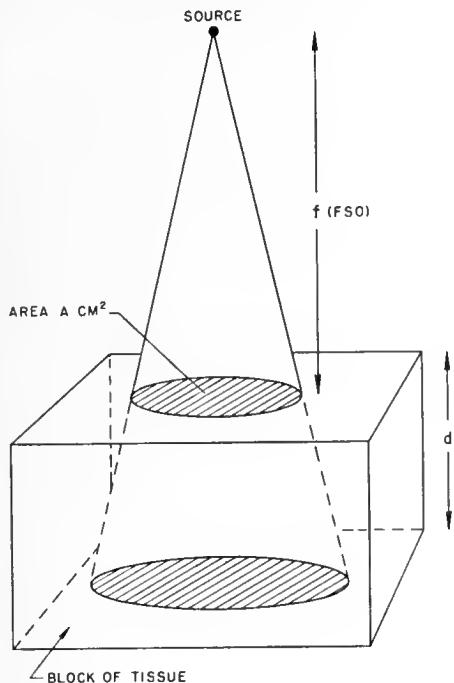

Fig. 4—Quantities used in calculation of integral dose.

vary with the square of the distance, but in opposite directions, and their product is therefore constant. Variations in S(A) are brought about solely by changes in field area occasioned by moving the skin surface within the beam; it is known that S(A) varies slowly with field area, and calculation therefore reveals that changes in the first term of Eq. 1 are small.

The behavior of the remaining terms depends on how μ depends on the FSD in a beam of fixed solid angle. The relation between μ and f is

$$\mu = af^{-b} \tag{3}$$

The constants are such that the second term in Eq. 1 varies little over considerable ranges of f. The term Δ is also largely independent of f. When all three terms are multiplied, it is found that the net variation in Σ_d does not exceed 20 per cent for extreme changes in f, and, for small oscillations about a mean f (such as those encountered in rotation therapy), the expression has, for all practical purposes, a constant value. It would be wrong to attribute any deep theoretical significance to this result; it is a numerical coincidence. It is, however, a fortunate one because it means that, as far as integral dose is concerned, it no longer matters how far the source of radiation

is from the skin surface, provided the solid angle and the time of irradiation do not vary.

One difficulty remains: the body thickness presented to the beam changes as the beam circles the patient. The thickness enters into the expression (Eq. 1) through the factor $e^{-\mu d}$ only; nevertheless, it might seriously affect the integral dose. If we return to the example we first considered, i.e., a cylindrical patient whose axis does not coincide with the axis of rotation, it is possible to calculate the average beam length within the body while the beam completes a revolution or any part of a revolution about the patient. The calculation involves integration of the beam length in a given angular position (as found by geometrical methods) over the required arc and division by the total angle. It turns out that the average beam length deviates little from the diameter of the cylinder for all positions of the axis of rotation between the axis and the edge of the cylinder. The deviation that exists is not sufficient to alter the second term of Eq. 1 significantly. Therefore the integral dose in eccentric rotation about a cylinder can be related simply to the exposure, HVL, and solid angle. (The factors describing these relations are now in process of tabulation.) When the body has an elliptical cross section, it is extremely tedious to calculate the average beam length for all possible positions of the center of rotation; but it is clear that a graphical presentation to cover all likely cases is possible. The procedure envisaged is to find some easily measured characteristics of the ellipse, such as the eccentricity and the length of one axis, and to look up the average beam length and the average FSD in a table that gives these quantities in terms of the measured characteristics. The time necessary to deliver the required tumor dose will be known, and multiplication of this time with a factor derived from graphs yields the integral dose.

This method is identical with the experimental approach by Dr. Hayes. It remains to be seen whether the two systems can be reconciled. Dr. Hayes is working at an energy much higher than 200 keV, and it would therefore be interesting to learn whether the considerations I have spoken of apply also at the higher energy. When the matter is investigated numerically, it is found that the variation with the FSD is slightly less at high energies and the system proposed by Dr. Hayes for Co^{60} and Cs^{137} is therefore likely to give very accurate results. At the present time both theory and experiment are valid for homogeneous bodies only.

In this brief recapitulation of facts, I have tried to show that the evaluation of dose at a point or in a volume can now be tackled for moving-beam patterns of considerable complexity; calculation and experiment are progressing so rapidly that dosimetry at all energies is no longer the bugbear it was when moving-field machines were first introduced.

Reference

1. J. E. O'Connor, A Method of Estimating Doses in Arc Therapy, *Brit. J. Radiol.*, 27: 453-458 (1954).

Experiences with Clinical Moving-field Dosimetry

CHAPTER 7

Stanley H. Clark

Cedars of Lebanon Hospital*
Los Angeles, California

Abstract

In the course of planning for the installation of a 1000-curie cobalt teletherapy unit utilizing rotation therapy, it was decided that the most direct possible methods of measuring tumor dose should be used. In addition, direct means of patient alignment were considered.

A method for measuring tumor dose was selected after trial of a number of materials for construction of patient phantoms. The material currently in use is a thermosetting plastic-cloth combination originally developed by Singer Sewing Machine Co. for making dress-model forms. This material is molded to the patient's body and subsequently used with Lincolnshire bolus beads to study the dose distribution within the body volume. Various types of ionization chambers, rate meters, etc., are used for the actual dose measurements. This technique has proved satisfactory and has been in use as a routine procedure for about two years.

The patient alignment technique selected was a combination of fluoroscopy and television viewing. In practice an X-ray unit, television camera, and image intensifier combination is used for viewing the area undergoing treatment. The technician or radiologist can then adjust the patient from the control panel, by viewing the television screen, so that the rotating tumor volume coincides with the cobalt beam. This technique has proved particularly useful in irradiation of very small fields, such as the pituitary, where pinpoint localization is essential.

Two additional means developed for accurate alignment are described. The first is a long-decay-time phosphor, which allows quick visualization of the actual field distribution. The second utilizes a scintiscanning device to plot automatically isodose patterns from X-ray films.

At the Cedars of Lebanon Hospital, Los Angeles, we have a Keleket-Barnes Co⁶⁰ teletherapy unit containing about 1000 curies.

It was decided in the course of planning for this unit that the most direct possible method of measuring tumor dose should be used. This meant either positioning an ionization chamber in the patient's body or duplicating the structure and X-ray absorption characteristics of the patient's body and then making measurements in this phantom.

Two limitations prevented the use of ionization chambers in the patient's body: the lack of a really dependable small ionization chamber that could be used in a flexible tube and the location of a tumor in an inaccessible region.

Thus the second method was adopted, with only limited augmentation by direct body-cavity measurements. Accuracy, simplicity, and rapidity, in that order, were the primary guiding criteria in establishing this program.

Many phantom materials and body-molding techniques were originally tested or considered and then discarded because they did not adequately meet the criteria. For two years we have been using a body-molding material developed by the Singer Sewing Machine Co., with some modifications in technique of application. This material is relatively cheap, is easily applied by an experienced person, and subjects the patient to little or no discomfort. The time required for molding the average patient is about 10 min. Completion of the phantom for use in dosage studies requires, on the average, an additional $\frac{1}{2}$ hr.

Figure 1 illustrates the techniques for molding the thermoplastic material. The technician applies another piece from the back of the patient and then removes the two parts and staples them together, keeping the body dimensions of the patient recorded on a standard sheet; thus all dimensions are duplicated to within 1 cm or less.

Figure 2 shows a group of model forms. We have nearly 100 of these, catalogued; so we can duplicate dimensions of about 95 per cent of all new patients with existing model forms. Models are sealed on the bottom to contain Lincolnshire bolus beads or water; the latter is used for a scanning type of study of isodose distributions with stationary portals.

Figure 3 demonstrates a typical use of one such form, filled with Lincolnshire bolus with a Phantowax cross section of the body drilled out to duplicate lung density. A number of holes have been drilled in the lung cross-section shape. The dosimeter used for plotting isodose curves in this case was the Landsverk

*Present address: Martin Co., Nuclear Division, Baltimore 3, Md.



Fig. 1—Method used for molding thermoplastic material about the patient, the first step in preparing a patient phantom to be used for dosage studies.



Fig. 2—A variety of patient phantoms made by the technique illustrated in Fig. 1. Phantoms are re-used when dimensions are suitable.

50-r chamber, which is available commercially in this country and is convenient for making a series of measurements. It is economical and reasonably reliable.

Figure 4 shows a close-up of a set of Phantowax cross sections used for studies in a plane through the lung and the chest. We use 12 chambers. The actual air volume of these chambers is small. They are about $\frac{1}{16}$ in. in diameter and about $\frac{1}{8}$ in. long; thus they constitute nearly point-source measurements.

Figure 5 illustrates a more routine clinical measurement technique. With the Victoreen Radocon, a series of measurements is made at the tumor axis, occasionally at other points of interest in the plane of the patient's body, in the plane of the beam in the patient's body, and occasionally outside the plane of the beam.

One of the favorable aspects of using phantom measurements for each patient is that it allows one to make measurements of scattered radiation outside the treatment plane as easily as it does on the axis of rotation or anywhere else in the phantom. The balsa-wood lungs, which simulate lung density, are barely discernible in Fig. 5. The dimensions are derived from a standard cross-section anatomy book.

Figure 6 shows the Victoreen Radocon and the associated recorder. This device is a combined rate meter and integrating meter. We use this not for transmission doses so much as to measure the variation of the tumor dose or axis dose as a function of angular position. In the chart shown in Fig. 6, it can be seen that a recording of such information is visible where the dosage rate at the tumor site varies with body angular position. We also use the integrating part of this meter routinely for recording the tumor dose, spinal dose, cord dose, etc.

Figure 7 illustrates the image tube-television system, which consists of a Kay Lab closed-circuit television system and Phillips image intensifier and a specially designed 1-mm focal-spot X-ray unit that produces 125-kv X rays. This entire unit is rolled into position until the rotating patient is in the region between each unit. Thus we look at the actual volume being treated 90 deg early or 90 deg late, depending on the direction in which the patient rotates.

The plane of the cobalt beam is duplicated by a set of vertically mounted tapes on each unit; therefore all that is necessary is that the X-ray unit and the cobalt unit be set on the same number, thus assuring that the plane of the cobalt beam is in the plane of the tumor.

We have tried to localize accurately very small beams (Fig. 8). Pituitary irradiations have been the most critical and the most demanding in terms of careful beam directing. Also it was necessary to firmly couple the axis of rotation (above the rotating system) with the solid structure of the cobalt unit to prevent wobble of the rotation axis. The rod at the top of Fig. 8 is the axis of rotation and is aligned with the pituitary so that the lead beads (which are barely visible) are lined up with the axis. This is first done with the cobalt beam in the television-image tube sys-

tem and then with the X-ray produced image so that the *sella tursica* is superimposed on the picture viewed. We are thus able to place the 1.5-cm-diameter beam exactly on the pituitary before and during rotation therapy. Further details about the use of this technique will be discussed by Dr. Jaffe.

Figure 9 shows various head phantoms constructed of Singer Sewing Machine Co. thermoplastic material, which can then be filled with Lincolnshire bolus. Also shown is a more conventional head phantom made of laminated pressed wood.

Figure 10 is an illustration of the way the gamma beam is distributed from the pituitary cone in the plane of the pituitary gland. It is about 2 cm wide at the pituitary.

The localization possible with a small field and rotation is shown. It represents a 270-deg rotation with film again in the plane of the pituitary. The film used for this illustration is not of particularly high contrast. The dosage rate in the region outside the pituitary is lowered by a factor of 10 because of the small field size.

Figure 11 shows the bead cross section through the pituitary, with one 1-cm Co^{60} beam, 270-deg rotation, and 70 cm source-to-axis distance (SAD).

The curves in Fig. 12 show the distribution of ionization in a circular polyethylene container filled with Lincolnshire bolus beads. You can see the change in the peak ionization as a function of angle, i.e., how the point of maximum ionization changes position as the rotation angle is increased or decreased. By observing the maximums of each of these curves, it can be seen that the peak ionization follows in a certain order. There is a little asymmetry on the 360-deg curve (Fig. 12) which, if rotating conditions had been ideal, would have been smoothed out. Then it would probably have been a curve with two symmetric humps. These curves were made using a fairly large field size. The field width can be determined by looking at the 360-deg rotation curve and measuring the distance from hump to hump, or, in the case of the 180-deg curve, by measuring the distance from the peak ionization to the rotation axis and then doubling this distance.

These data were then rearranged for clinical use by plotting the distribution of the ionization axis (the point in the plane of rotation where peak ionization occurs) as a function of angle and distance from the anterior side (Fig. 13). Four standard cones were used before we had obtained an adjustable diaphragm, and thus the choice of these particular field sizes are arbitrary in terms of our present available field sizes.

Figure 13 shows that, for 180-deg rotation, the tumor axis should be located about 1 cm in front of the axis of rotation for a 4- by 4-cm field. Notice that for larger fields, such as 13- by 18-cm fields using 180-deg rotation, the peak ionization falls at half the field width. This is always true at 180 deg. At 0-deg rotation we find that the peak ionization is essentially at the surface of the circular phantom, whereas at 360 deg the axis of rotation and the axis of ionization coincide.



Fig. 3—Cobalt unit and a patient phantom simulating an actual patient arrangement. Note the Phantowax lung cross section and Landsverk ionization chambers.

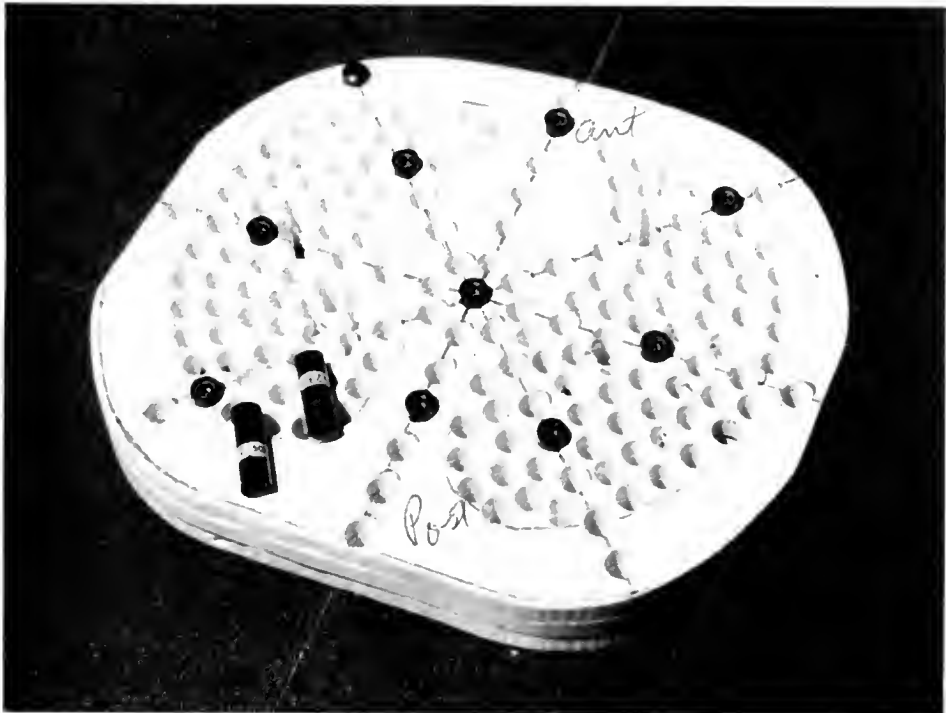

Fig. 4—A close-up of the Phantowax cross sections that are used for studies in a plane through the lung and the chest.



Fig. 5—The Victoreen Radocon is positioned in the chest phantom at the point where the dosage is desired. The phantom is then rotated through the selected arc.



Fig. 6—The Victoreen meter and recorder used for measuring transmission doses and variations of tumor dose as a function of angular position.

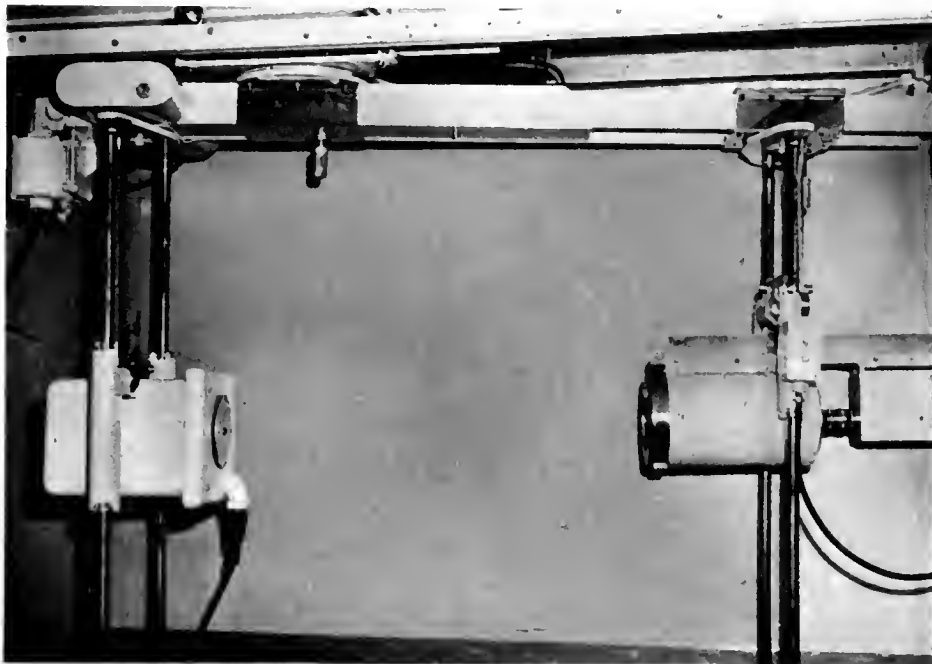

Fig. 7—Overhead mounting showing the image tube—television system (right) and the X-ray machine (left) used in viewing the patient before and during therapy.

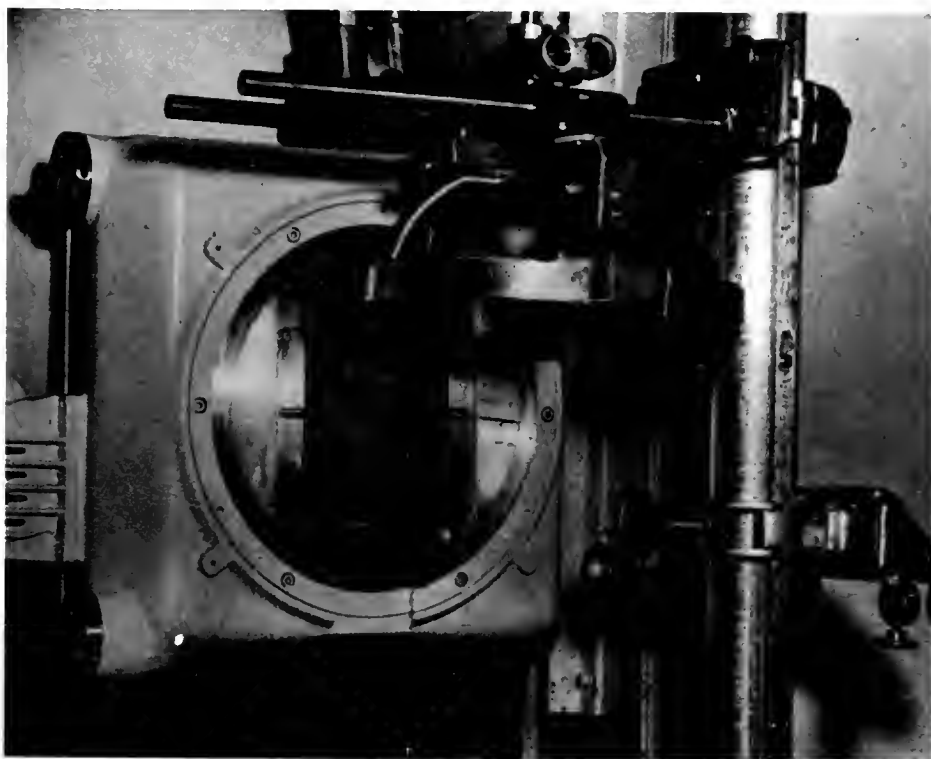

Fig. 8—Head clamp and associated equipment used in rotation therapy of the pituitary. Note the beam aperture, which produces a 1.5-cm-diameter gamma-ray beam.



Fig. 9—Phantoms of heads were made with thermosetting material (left) and bonded pressed wood (right).

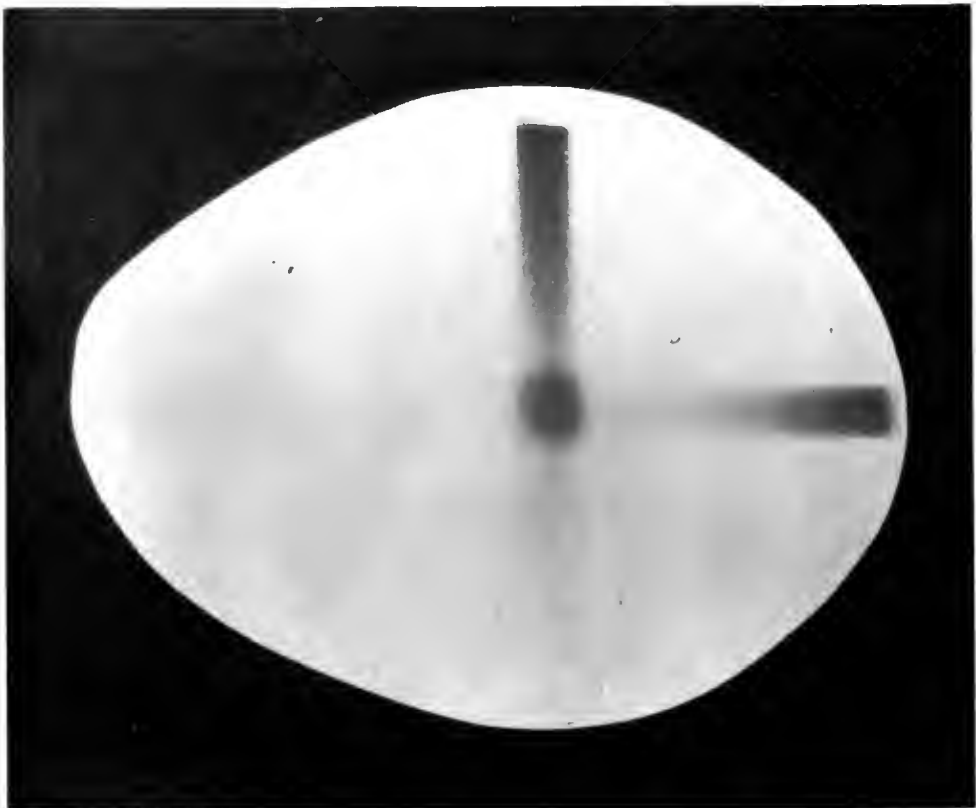

Fig. 10—Head cross section through pituitary. Two 1-cm Co^{60} beams; 70 cm source-to-axis distance.



Fig. 11—Head cross section through pituitary. One 1-cm Co^{60} beam; 270-deg rotation; 70 cm SAD.

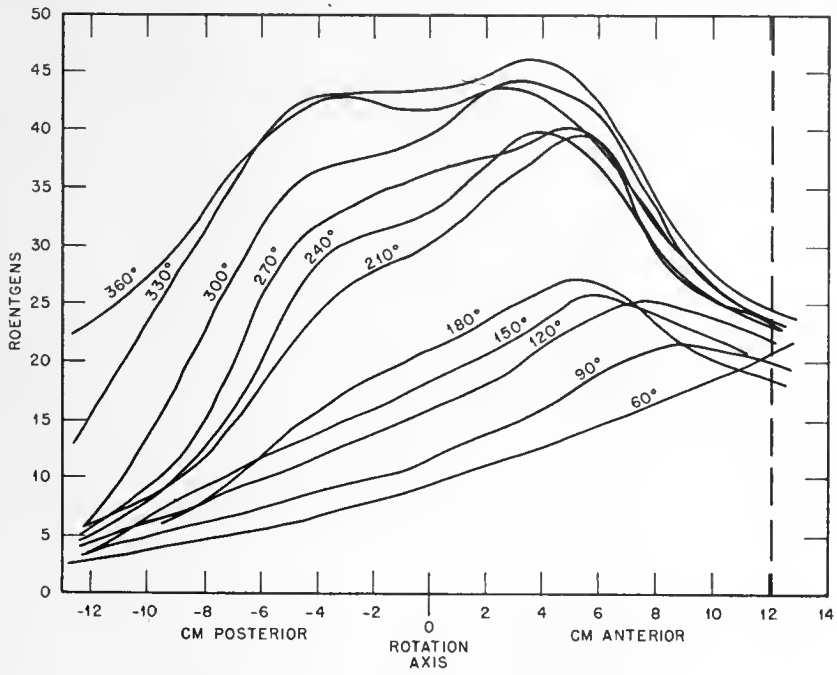

Fig. 12—Posterior-anterior ionization as a function of amount of rotation.

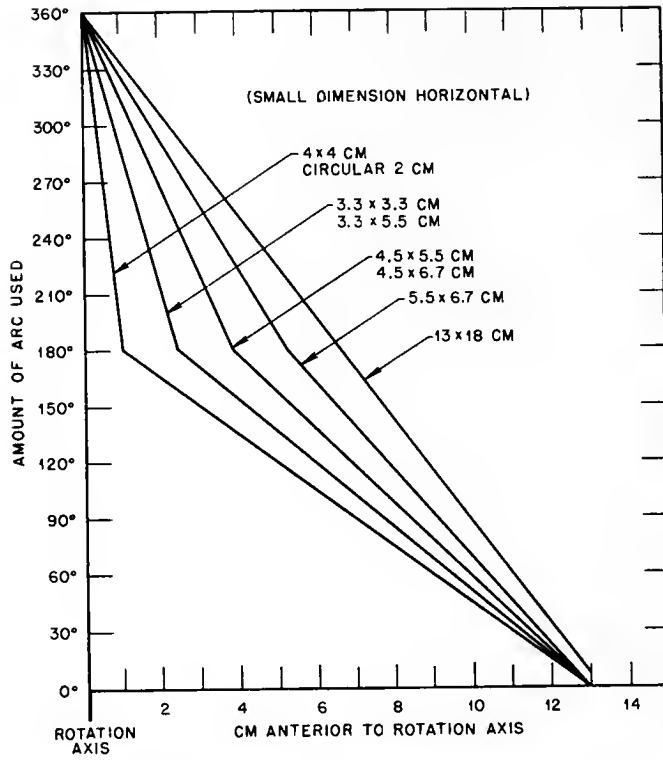

Fig. 13—Tumor axis as a function of total arc and field size at 70 cm from source; 70 cm SAD.

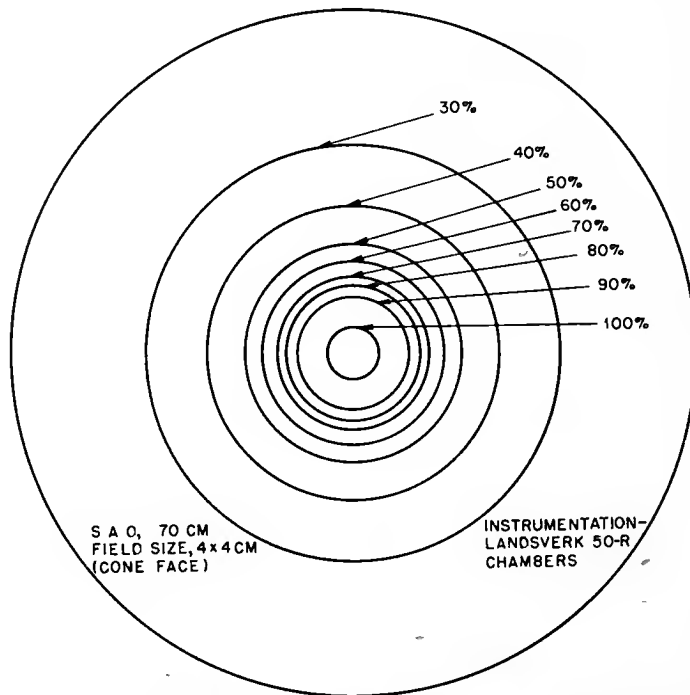

Fig. 14—Isodose pattern for a 360-deg arc; Co⁶⁰ vertical rotation.

This is one of the things Dr. Roberts mentioned earlier. The curves in Fig. 13 are drawn as straight lines. They represent some deviation from the experimental data but are accurate enough for clinical work

isodose lines represent fairly high resolution information. This is such a tedious technique that it forced us to seek simpler measurement techniques, which will be described later.

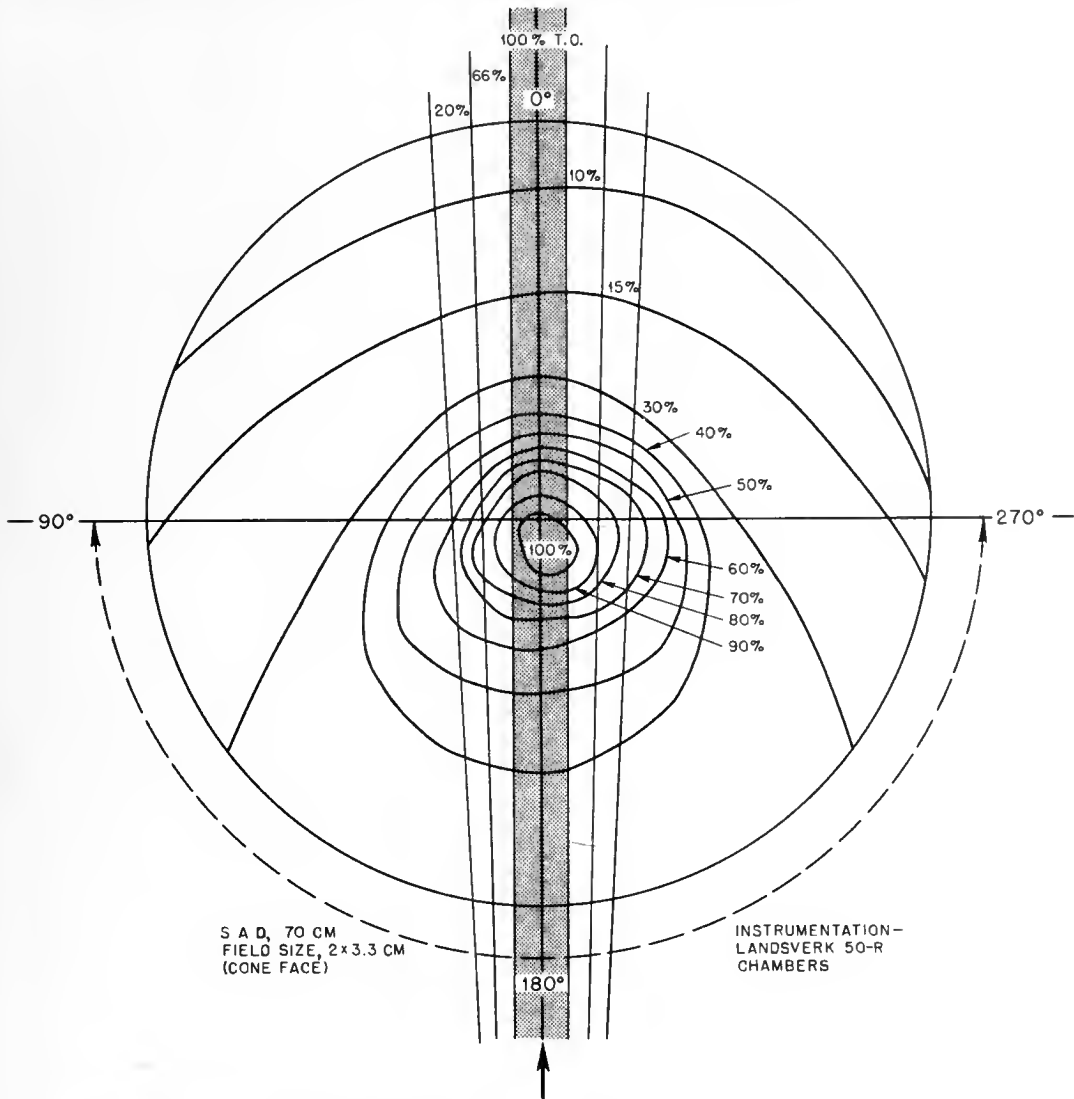

Fig. 15—Isodose pattern for a 180-deg arc; Co^{60} teletherapy; vertical rotation; horizontal beam; circular (13.7 cm radius) polyethylene phantom with Lincolnshire bolus material; axis of rotation, center of cylinder.

in determining where the tumor should be located with respect to the ionization peak (even though patients are not as a rule circular in shape).

Figure 14 is an example of isodose curves made with Landsverk ionization chambers, showing the very large ratios of tumor dose to skin dose which can be obtained in the average body dimensions with a 4- by 4-cm field.

Figure 15 depicts an arc of 180 deg using a small field, 2 by 3.3 cm. Measurements were also made with Landsverk chambers (125 of them in a coordinate system in the cross-section plane), and therefore the

Figure 16 also shows a 180-deg rotation with a much larger field than the preceding one. At the face of the cone the field is 5.5 by 6.7 cm, and at the axis of rotation, 10.5 by 13.3 cm. The skin dose is between 40 and 50 per cent of the tumor dose. Note that, whereas the axis of rotation is at the center of the cylinder, the peak ionization is about 5 cm from it in the direction of the incident beam. One must be sure to take this into cognizance in order to provide optimal ionization distribution in the tumor area.

Figure 17 is taken from a paper to be given in Mexico City (Eighth International Congress of Radi-

ology, July 1956), but it is most pertinent to the discussion here. This study was directed toward evaluating the treatment of a given tumor with a variety of different field conditions. By weighing various factors,

the point of peak ionization, in the center of the tumor, but slightly behind it. This represents a compromise necessitated by the high cord dose if the ionization axis were superimposed on the tumor. It was possible

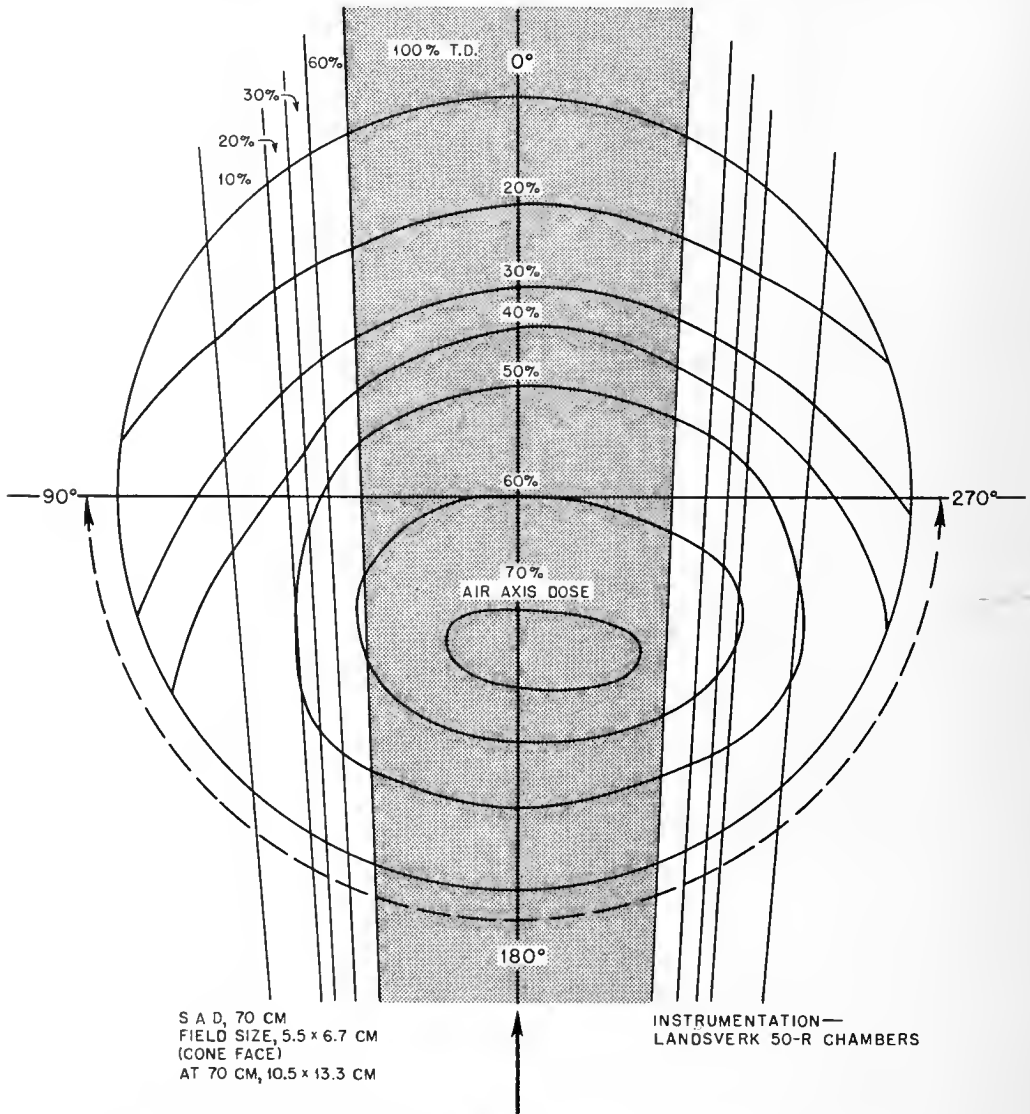

Fig. 16—Isodose pattern for 180-deg arc; Co⁶⁰ teletherapy; vertical rotation; horizontal beam; circular (13.7 cm radius) polyethylene phantom with Lincolnshire bolus material; axis of rotation, center of cylinder.

such as the cord dose, the tumor dose, and the skin dose, we hoped to be able to select the optimal combination of conditions. With the two-field technique the tumor dose is large with respect to the cord dose, but the skin dose is more than three times the tumor dose. One should observe each bar graph with these factors and their ratios in mind. Evaluating these graphs in terms of the optimal treatment, we decided that 180-deg arc, with the axis of rotation not quite on the tumor (note the sixth bar from the top of Fig. 17) but slightly off, gave us better protection for the spinal cord; we did not put the axis of ionization, i.e.,

to decrease the cord dose because of the rapid fall-off of the ionization posteriorly to the tumor.

Figure 18 looks like the reproduction of an X-ray film. In reality it is a contact print made from a slow-decay phosphor screen. We use such screens for quickly determining the field distribution of ionization in any cross section. The phosphor screen is observed in a darkened room within 1 or 2 min after exposure.

Figure 19 shows the appearance of a 270-deg rotation, also a contact print on a slow-decay phosphor screen which can be viewed immediately after rota-

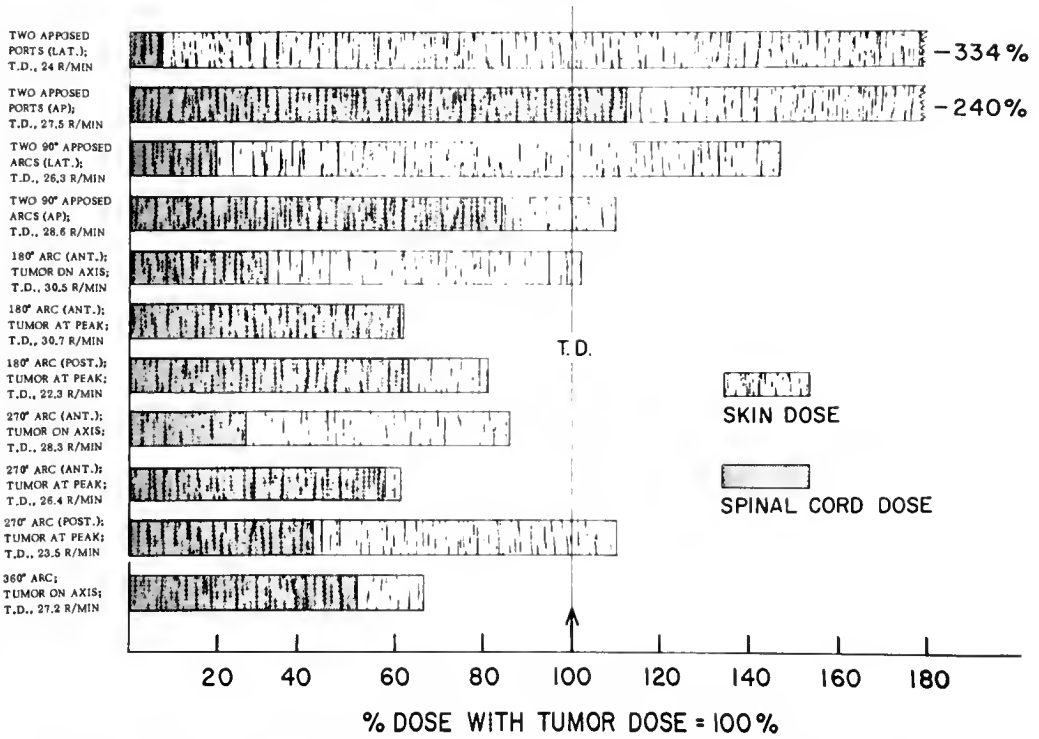

Fig. 17—Evaluation of dosage factors in cobalt rotation therapy. Lateral, 35 cm; anteroposterior, 36 cm; Lincolnshire bolus; irradiation of bladder (cervical) region; field size at axis, 10.5 by 13.3 cm; SAD, 70 cm; instrumentation, Radocon; percentage of values calculated for tumor dose, 100 per cent.



Fig. 18—Contact print made from a slow-decay phosphor screen by first exposing the screen and later placing it in contact with film.

tion. For a permanent record a piece of photographic paper is placed with the phosphor in a cassette and exposed for a few minutes. In this case we used Kodak

These screens were made from a Du Pont phosphor (No. 1305) and a plastic material called "anaerobic permafил" (MPL-monomer-0.006 per cent hydroqui-



Fig. 19—Contact print on a slow-decay phosphor screen; 270-deg Co^{60} rotation; Kodak type K film.

type K film. Sometimes we use high-contrast film or high-speed printing paper.

Figure 20 shows a contact print made of an X-ray film (using light exposure in place of X-rays). In this case I wish to demonstrate the quality of the screens. Notice that the phosphor is light sensitive as well as X-ray sensitive. [At this point a slow-decay phosphor screen was demonstrated by exposing it to light and then darkening the room.] The light intensity obtained here by exposing the phosphor to visible light is about equivalent to that brightness obtained with 3-min exposure in the cobalt beam. You can look at the ionization distribution immediately and, of course, reuse the screens after the light has decayed.

none, American Monomer Corp., Leominster, Mass.). I suspect that Du Pont or other manufacturers could make much better screens than I made.

Finally I shall discuss a simple method of making isodose patterns, particularly in the United States, where a number of people now have scintiscanners for gamma-ray scans of various body areas (Figs. 21 and 22). By mounting a film holder on the end of the arm that normally holds the scintillation counter and then having this frame and film move back and forth through a densitometer, it is possible to scan the entire film. By coupling the densitometer microammeter with another microammeter that digitizes the meter output, it is possible to print as many as 11 different isodose

curves in a single film scan. We are now using a Macbeth-Ansco densitometer because of its ability to measure densities over a greater range.

but now, by first plotting a roentgen vs. density curve and then putting in the actual roentgen values on the isodose curve, we can show the exact roentgen values



Fig. 20—Contact print produced by exposing phosphor to a light source with intervening X-ray film and subsequently contact printing while the phosphor decayed.

It is possible to print isodose curves of any cross-section film in $\frac{1}{2}$ hr. This technique is valid for cobalt radiation, but it is not valid for energies under 400 kv (gamma emitter or 1-Mv X-ray peak energies). Since isodose curves are easy to produce in this manner, we anticipate inclusion in each patient's chart of an actual isodose pattern made by this scanning technique.

In the past we have used the cross-section films qualitatively to determine the ionization distribution;

on the isodose curve. We can show the exact distribution in the cross section we are treating.

Figure 23 shows the first isodose scan that was made with this system. I was the digitizer, clicking the relay every time we passed a given density value; therefore the points are a little more scattered than they would have been if they had been controlled electronically. However, it duplicates, at least qualitatively, the pattern very nicely. [A unique electronic digitizer is now completed for this application (April 1957).]

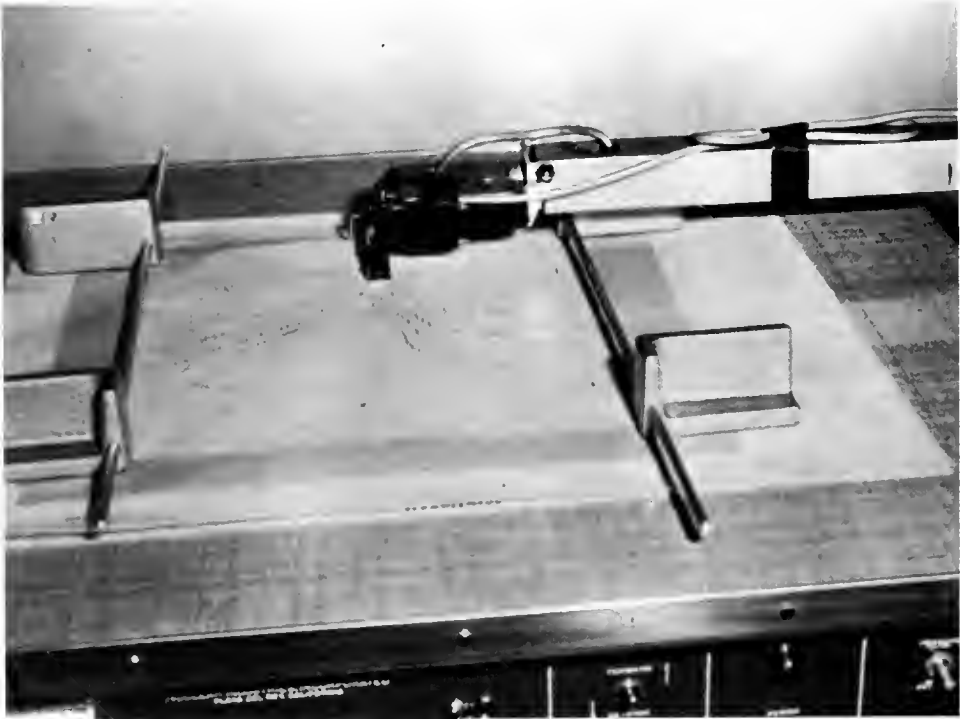
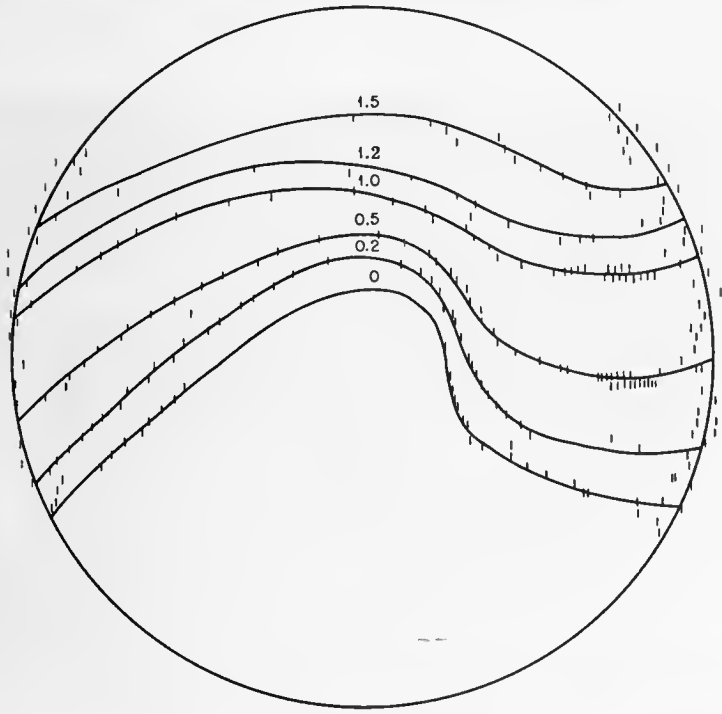

Fig. 21—Automatic isodose plotting device used for scanning X-ray film.



Fig. 22—Scanning arm and densitometer portion of automating film-scanning isodose plotter.



(a)



(b)

Fig. 23—Isodose film scan: 180-deg tangential field. (a) A print from isodose data; (b) the original film.

The field illustrated is a 180-deg tangential field similar to the fields used for breast work; it was made in a circular phantom. I have made a number of

were loaned by the U. S. Naval Research Laboratory for these tests.] It amounts to about 1 half-value layer for Co^{60} gamma rays. Such crystals have been used

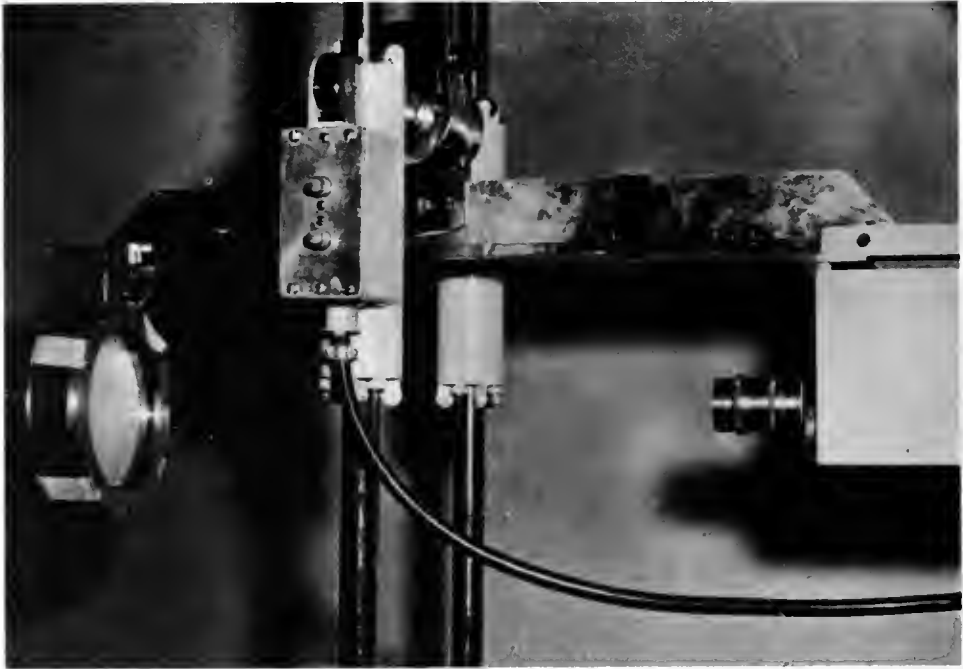

Fig. 24—Experimental viewing with a vidicon television system of a sodium iodide crystal exposed to Co^{60} gamma rays.

similar scans. The one that is shown in place on the machine is different from the one illustrated.

The scanners will scan commercially an area 15 by 20 in., which is large enough to cover any size film that you might wish to scan. This adaptation to the scanner was put into operation in one afternoon; it is a very simple application of a scintiscanner.

Figure 24 shows a 5-in. sodium iodide crystal 1 in. thick being used for image intensification. [These

by the National Bureau of Standards in a similar manner for industrial television fluoroscopy.

A structure in air-cavity regions such as the lungs can be seen much the same as it would appear on a good cobalt film. It is just another possible approach, which is somewhat cheaper than electronic intensification and affords the possibility of viewing a much larger field size than the currently available image intensifiers do. However, we have made only preliminary observations; further studies should be made.

Chemical Measurements of Integral Dose

CHAPTER 8

Raymond L. Hayes

Medical Division
Oak Ridge Institute of Nuclear Studies
Oak Ridge, Tennessee

Some therapists think integral body dose may become a limiting factor in teletherapy treatment of tumors, particularly when complex rotation patterns are involved. Chemical dosimetric techniques, though low in sensitivity, are well suited to the direct determination of integral doses. Chemical dosimetry measurements with a simplified two-compartment phantom have been used to study integral dose as a function of source distance, tumor size, torso size, and position of the tumor in the torso under both stationary and simple rotational conditions. A portion of the data accumulated is presented.

In general, one or more of the following may act as the limiting factor or factors in X- or gamma-ray treatment of cancer by teletherapy devices.

1. Dose to adjacent vital tissue
2. Dose to skin
3. Dose to total body

Limitations imposed by the dose received by vital normal tissue adjacent to the volume under treatment will vary with the individual patient and may well be the limiting factor, regardless of the technique and teletherapy instrument used.

Limitations imposed by the dose received by the skin can, to a large extent, be overcome by an increase in the energy of the radiation used or by the use of multiple ports. In addition, rotation techniques will further decrease the dose to the skin, as well as the dose to any particular volume of normal tissue. However, with rotation treatment, if the problem of dose to vital tissue is excluded, the integral dose or the total energy received by the patient's body will tend to become the limiting factor in any course of treatment. Thus a knowledge of relations between tumor dose and integral dose is potentially important, particularly where complex rotation patterns are involved. Accordingly, we have been interested in the experimental determination of integral dose, particularly under conditions of rotation treatment.

A method that readily adapts itself to this type of measurement is aqueous chemical dosimetry. It is

generally accepted that the action of ionizing radiation on water leads to the production of hydrogen atoms (H) and hydroxyl radicals (OH). These may combine with each other in various ways, or, in the presence of a suitable solute, they may cause a chemical change to occur. If this chemical change is proportional to the energy absorbed over a suitable range of dose, the system constitutes a possible chemical dosimeter.

Dr. Loevinger and Dr. Roberts indicated that chemical dosimetry is useful for integral-dose determinations, but they questioned the applicability of this method at the present time because of the insensitivity of available dosimeter systems. Chemical dosimeter systems at present, it is true, are quite insensitive, but, by using extended exposure times with teletherapy equipment, we have found this technique to be quite useful for measurement of integral dose.

The main advantage of chemical dosimeter systems is that they lend themselves to the direct determination of integral or total-body dose since in effect these systems are self-integrating. This arises from the fact that chemical dosimeter systems may act as their own phantom mediums since, when the system used is an aqueous one, it will approximate tissue. In addition, their yields per unit of energy absorbed are based, at least indirectly and often directly, on calorimetric measurements. This fact allows one to measure the dose directly in rads rather than converting from roentgens to rads as would be done with ion-chamber measurements. Of course the computation can be made in whatever units are desired.

In addition, the phantom can be compartmentalized to any desired extent. Figure 1 shows a compartmentalized phantom that we plan to use in dose determinations with internal as well as external radiation sources. The internal sources used can be either discrete or completely extended, as, for example, when a radioisotope is added directly to the dosimeter solution. Sensitivity is a major problem with this latter type of study.

Perhaps the best known and most investigated chemical dosimeter in use at the present time is the ferrous sulfate system.^{1,2} It is, in general, considerably more sensitive than other available systems, and for these two reasons it was chosen for use in our initial studies.

I understand that at the present time the total mechanism involved has not been completely worked out.

The G factor, or chemical yield, is now generally accepted to be 15.6 Fe(III) ions produced per 100 ev of energy absorbed.⁴ On a molar basis this yield is equivalent to 1.6×10^{-11} mole or $1.1 \times 10^{-3} \mu\text{g}$ of Fe(III)

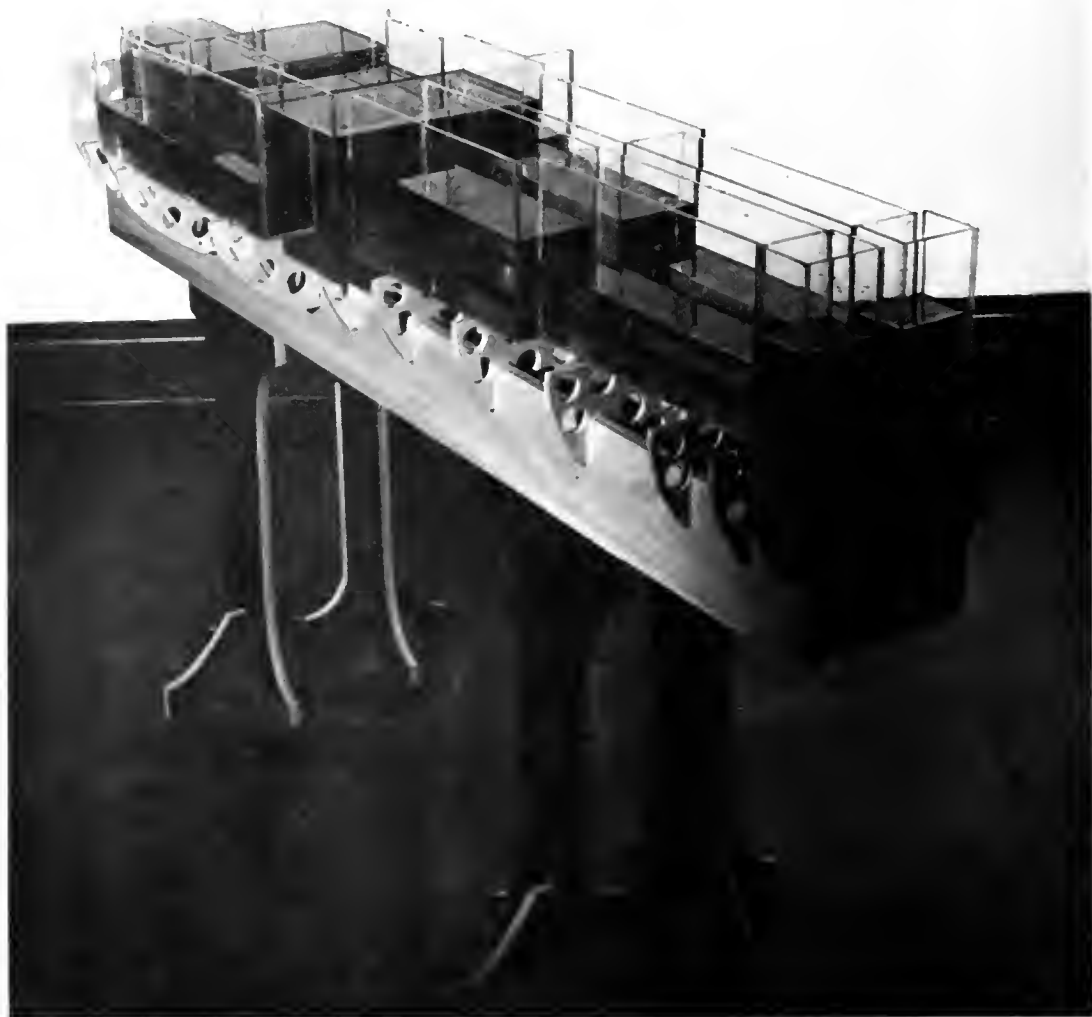

Fig. 1—Compartmentalized standard-man phantom.

The ferrous sulfate system as used in our studies consisted of an approximately 0.001M air-saturated solution of ferrous ammonium sulfate that was 0.8N with respect to sulfuric acid and 0.001M with respect to potassium chloride. The latter halide salt was included to decrease the possible deleterious effects of any slight organic impurities that might have been present in the solution.³

The over-all reaction resulting from the interaction of ionizing radiation with this system is the oxidation of Fe(II) to Fe(III):



produced per rad. This low yield constitutes the main difficulty in applying this chemical method to dose determinations, particularly where low dose rates are involved. It should be stressed that success with the use of this system depends primarily on careful attention to analytical technique.

For air-saturated dosimeter solutions the total yield of Fe(III) is proportional to the dose received up to a dose of approximately 4000 rads; at this point there is an abrupt break in linearity. This break is associated with depletion of oxygen in the solution, resulting in a change in the reaction mechanism and a lowered oxidation rate.

The yield of Fe(III) per unit of energy absorbed is independent of incident photon energy at energies above approximately 200 kev. Measurements made at photon energies of approximately 20 kev show the yield to be approximately 75 per cent of that in the energy-independent region.⁵ Ferrous sulfate phantom

tions in the two compartments were each thoroughly mixed, and the amounts of Fe(III) produced per unit volume were determined spectrophotometrically at 305 m μ . From the known volumes of each compartment, the total energy absorbed in each compartment could then be calculated. The reproducibility of these

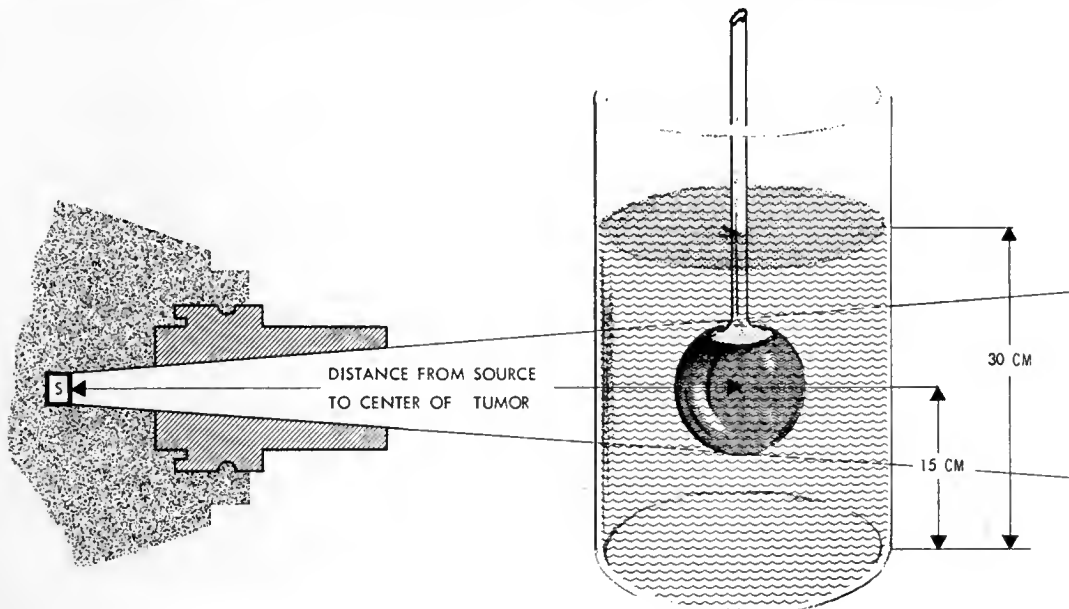

Fig. 2—Diagram of the two-compartment phantom used in this study.

measurements with Co⁶⁰ would not be influenced by this dependence at lower energies.

The yield per unit of energy absorbed is also independent of the ferrous iron concentration down to rather low molarities.⁶ In addition, temperature and pH effects are minimal.

To illustrate the use that can be made of chemical dosimetry in integral-dose determinations, I shall report briefly on a study carried out with the prototype model of the hectocurie Co⁶⁰ unit designed and built under the Teletherapy Evaluation Program (TEP). The results should apply only to this unit or units of similar construction. However, several points that the study brought out may be of general interest.

Figure 2 is a diagram of the two-compartment phantom used in this study. As indicated, the phantom was made up of a cylindrical torso compartment and a spherical tumor compartment. I was pleased to hear that Dr. Roberts thinks models of this particular type are not necessarily oversimplified.

In all measurements the circular collimating cones and the distance from the source to the center of the tumor were such that the geometric field just covered the outer periphery of the tumor. The tumor compartment was in turn centered vertically in the torso.

Measurements were carried out in the following manner. Tumor compartment and torso compartment were filled with ferrous sulfate dosimeter solution, as indicated in Fig. 2. After an appropriate exposure or treatment of a particular phantom setup, the solu-

measurements was usually about ± 2 per cent. On occasion it amounted to as much as 5 per cent.

Most integral-dose measurements made in this study were with stationary beams. But, as has been pointed out, such measurements would also be equivalent to measurements involving rotation of the beam around the vertical axis of the phantom or of the phantom about the vertical axis of the tumor if the tumor is centered in the torso.

Some of the studies were made, however, using rotation of the latter type with the tumor compartment displaced from the center of the torso. Figure 3 shows an eccentric positioning. Figure 4 is a double exposure of the same setup, showing the torso rotated about the central axis of the tumor through 180 deg.

As a means of comparing various techniques of rotation therapy, Dresner⁷ has suggested the use of what he has termed "treatment efficiency." This treatment efficiency, E , which we prefer to call "irradiation efficiency," is given as

$$E = \frac{\text{integral tumor dose}}{\text{integral body dose}} \times 100$$

where the integral body dose is the sum of the integral dose inside and outside the tumor compartment.

Admittedly, the efficiencies for different methods of treatment are certainly far from a complete description of their respective radiotherapeutic effectiveness. Nevertheless, they would seem to be worth

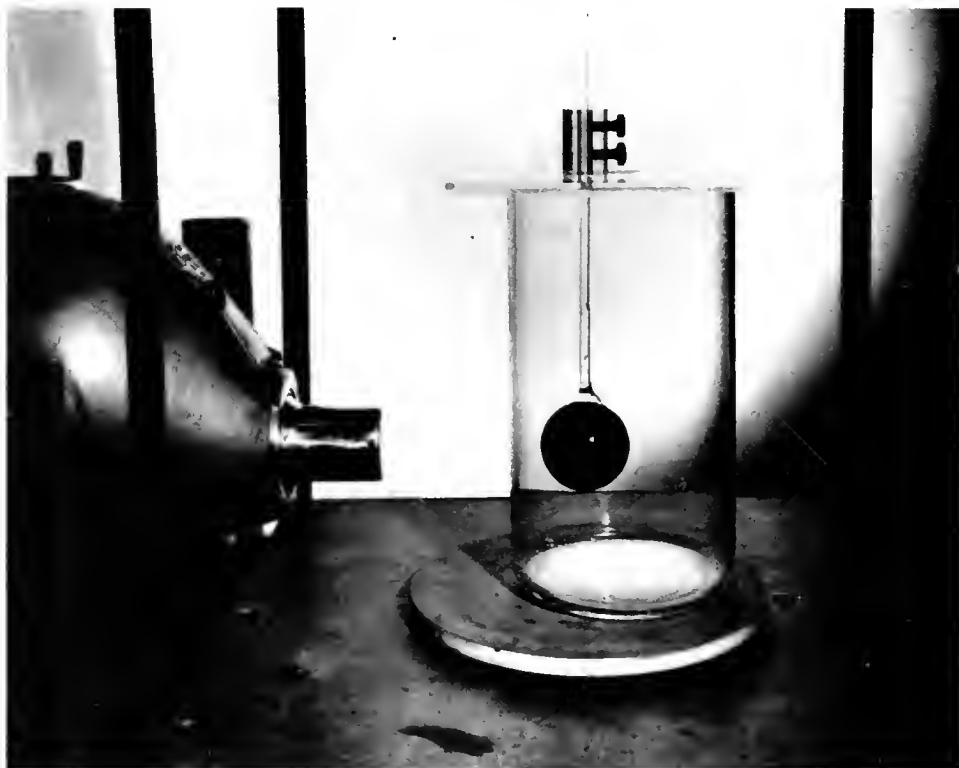

Fig. 3—An eccentric positioning of the tumor compartment.

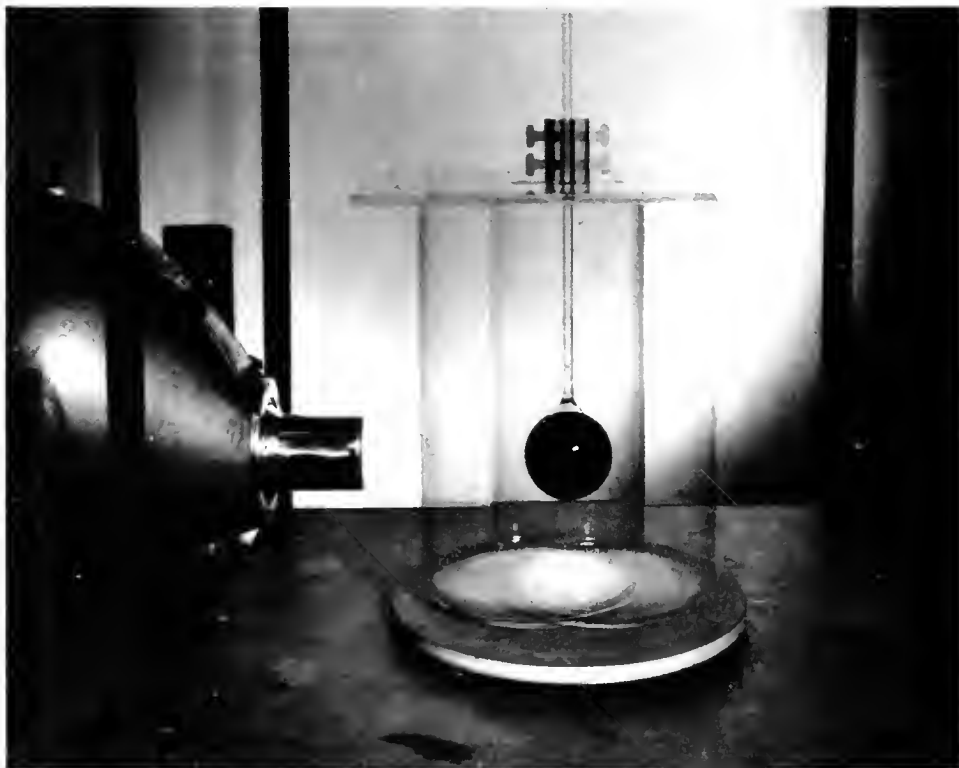

Fig. 4—Rotation of the setup in Fig. 3 shown with the double exposure.

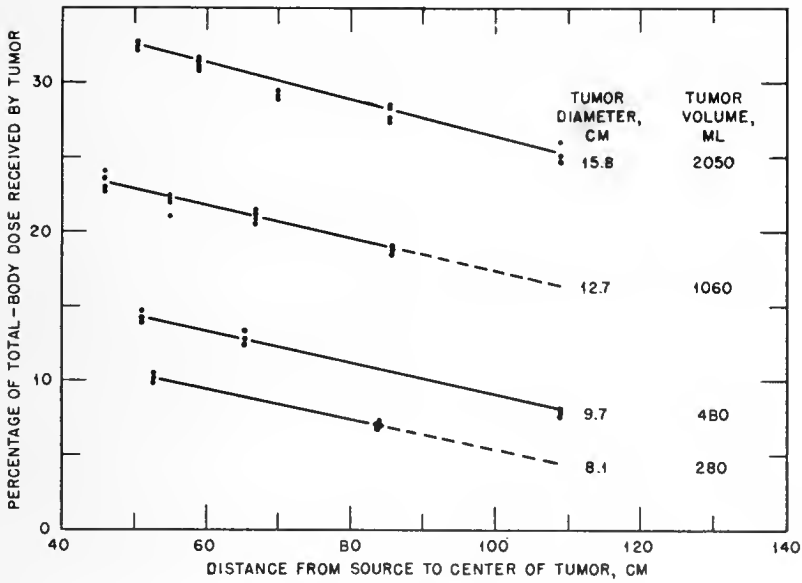

Fig. 5—irradiation efficiency as a function of distance from source (24-cm-diameter torso).

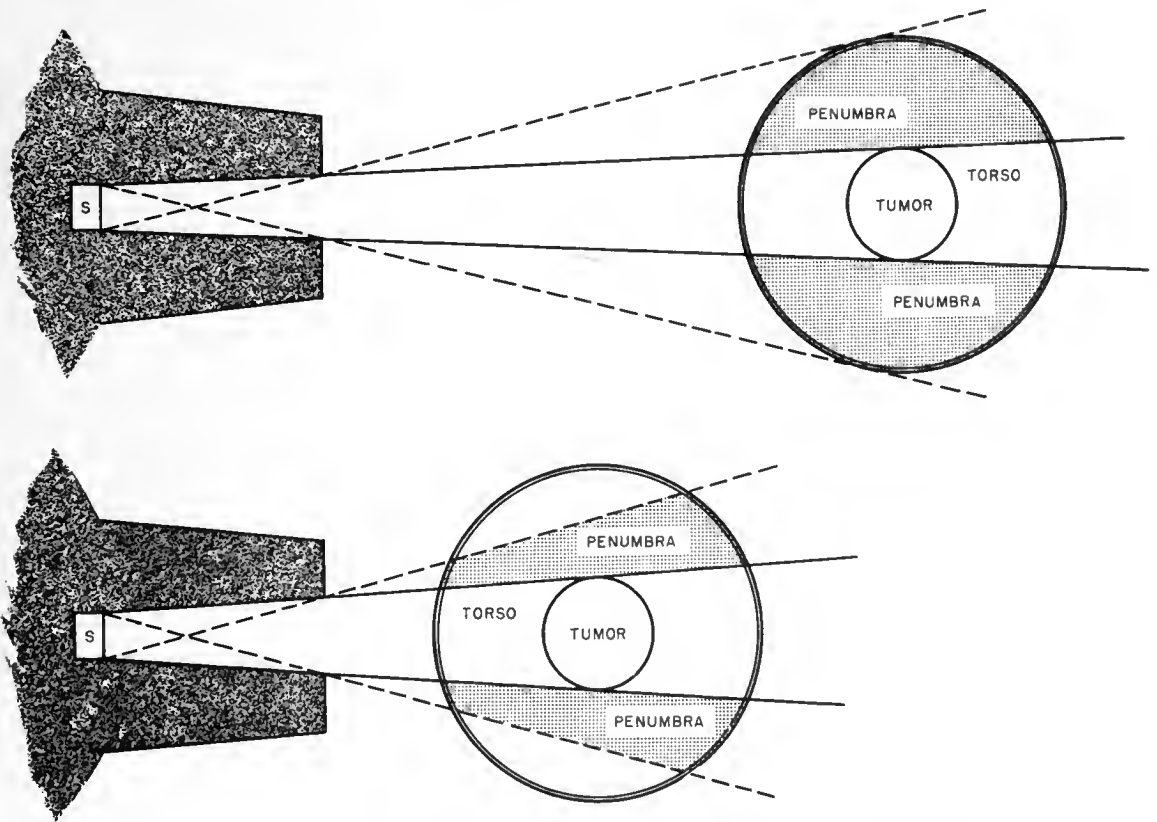

Fig. 6—Diagram showing the increase of penumbra with increasing source-to-tumor distance when the size of the tumor and the distance from the source to diaphragm are held constant.

determining, particularly where treatment is such that the integral dose is tending to act as the limiting factor in the treatment, as might be true with rotation therapy.

The increase of total-body dose associated with the decrease of irradiation efficiency with distance can be mainly ascribed to an increase in penumbral dose. Figure 6 shows a diagram that qualitatively illustrates

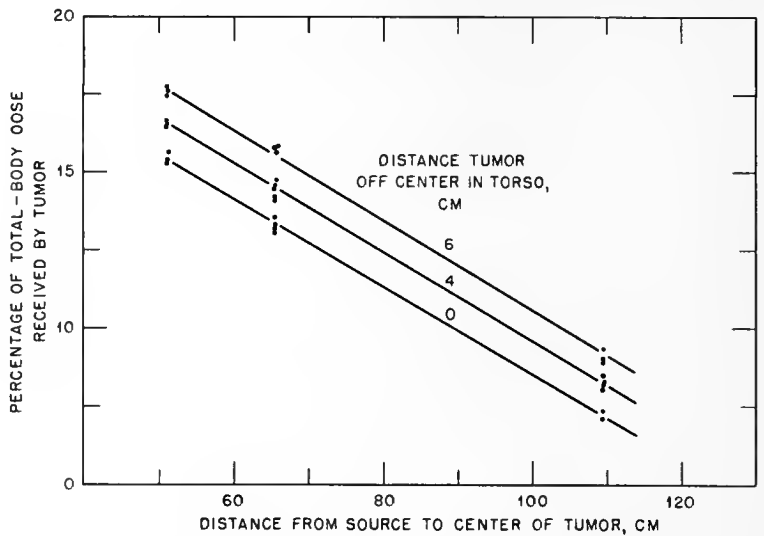

Fig. 7—Irradiation efficiency in rotation treatment as a function of the distance from the source.

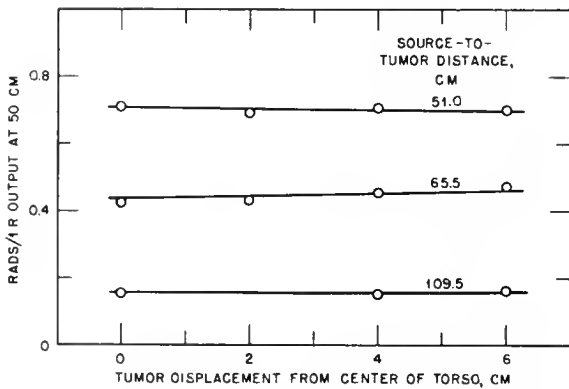

Fig. 8—Energy absorbed per gram of tumor as a function of tumor position in rotation treatment.

Figure 5 shows the results of a study of the irradiation efficiency as a function of the distance from the source to the center of the tumor for different-size tumors. Torso diameter was kept constant. Each of the individual points represents a single determination.

Interesting points of the study were the approximately linear relations that were obtained and the fact that the slopes of the lines were, in general, independent of the diameter of the tumor compartments.

The rather steep drop-off of irradiation efficiency with distance shown in Fig. 5 is to be expected with the hectocurie TEP unit. This will also be true of other teletherapy machines, the magnitude depending on source size and source-to-diaphragm distance.⁸ The source in the prototype unit is 2 cm in diameter and the source-to-diaphragm distance is 30 cm.

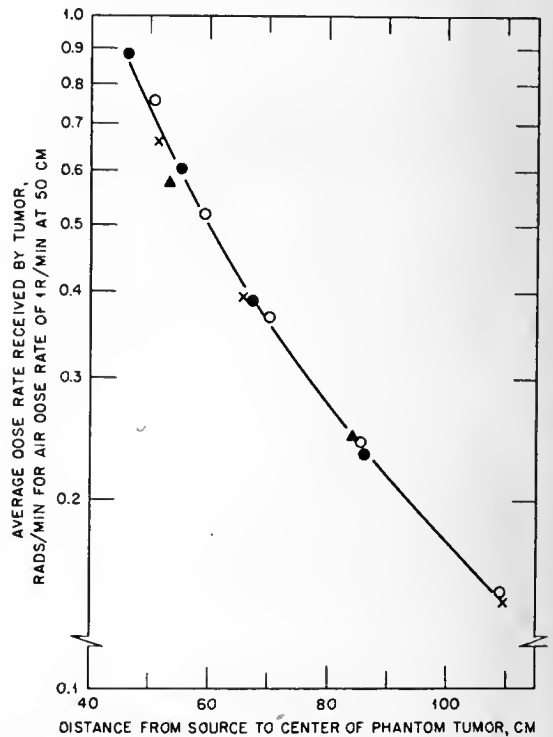

Fig. 9—Average dose rate received by tumor as a function of distance from source (TEP hectocurie Co⁶⁰ unit). Torso size is constant; tumor is centered in the torso; dose rate in air is measured on the central axis of the beam using cone E. O, tumor 15.8 cm in diameter and 2050 ml in volume. ●, tumor 12.7 cm in diameter and 1060 ml in volume. x, tumor 9.7 cm in diameter and 480 ml in volume. ▲, tumor 8.1 cm in diameter and 280 ml in volume.

the situation. The diagram represents treatment of the same-size tumor at two different source-to-tumor distances. Shaded areas represent the penumbral dose regions.

The study shown in Fig. 6 serves to emphasize in general the desirability of a short treatment distance with teletherapy machines of this particular design. It also emphasizes the desirability of longer source-to-diaphragm distances, but, of course, machine cost and output rates enter the picture.

Figure 7 shows the relation of the irradiation efficiency to the distance from the source when the phantom is rotated about the vertical axis of the tumor with the tumor displaced various distances from the center of the torso. Linear relations are again obtained. Furthermore, the slopes of these lines are independent of the distance the tumor is off center in the torso.

Figure 8 shows the average dose to the tumor as a function of tumor displacement in the torso for the rotation study treated in Fig. 7. The average tumor dose is, of course, the integral tumor dose divided by the tumor mass. Clearly the average tumor dose in the distance region studied is independent of the position of the tumor in the torso. Consequently it follows from these data that the increased efficiency observed with off-center rotation was solely a result of a decrease in the integral body dose.

Figure 9 shows a plot of the average tumor dose as a function of the distance from the source to the tumor

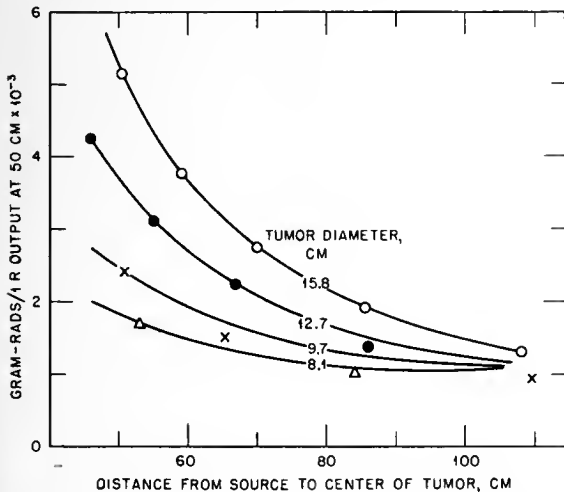

Fig. 10—A comparison of experimental (points) and calculated (curves) doses for integral body dose as a function of distance from source.

for varying tumor sizes. The tumor was centered in the torso, and the torso size was kept constant. As a first approximation the average tumor dose is roughly independent of tumor size. Furthermore, as might be expected, the average tumor dose decreases inversely with the square of the distance.

These are some of the more interesting sections of the data we have obtained using our simplified model. Studies of the effect of distance, tumor size, torso size, and position of the tumor in the torso under both rotational and stationary conditions have been made.

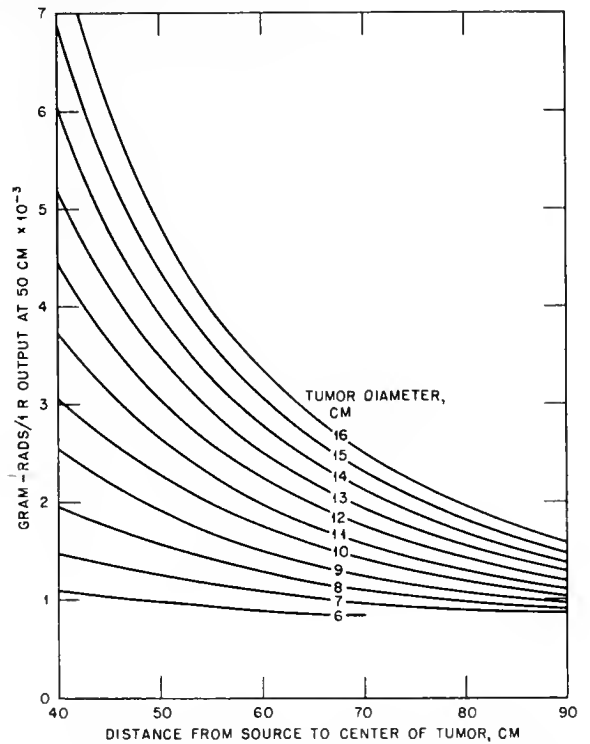

Fig. 11—Integral body dose as a function of distance from source in rotational treatment (TEP hectocurie Co^{60} unit). Torso diameter, 24 cm; tumor displacement, 5 cm from center of torso.

Although it was not the original purpose of these studies, it was found a relatively simple matter after analysis of the accumulated data covering the parameters mentioned to derive an empirical formula for the average tumor dose, the irradiation efficiency, and, indirectly, the integral body dose. The phantom on which the data are based is quite a simplified one. Figure 10 shows a comparison of the experimental and calculated doses for a portion of our data.

We have used these formulas to construct a series of plots with which it is possible to make rapid calculations of the average tumor dose and the integral body dose under varying conditions of torso size, tumor size, distance from source, and position of tumor in the torso with both rotation and stationary treatment. Figure 11 shows one of these plots.

In summary, although chemical dosimetry has a number of shortcomings (the main one being low sensitivity), it is a practical and direct method for measurement of integral dose. It is particularly suited to measurement of dose in rotation therapy.

References

1. N. Miller, Quantitative Studies of Radiation-induced Reactions in Aqueous Solution. 1. Oxidation of Ferrous Sulfate by X and Gamma Radiation, *J. Chem. Phys.*, 18: 79-87 (1950).
2. E. J. Hart, Radiation Chemistry, *Ann. Rev. Phys. Chem.*, 5: 139-162 (1954).
3. H. A. Dewhurst, Effect of Organic Substances on the Gamma-ray Oxidation of Ferrous Sulfate, *J. Chem. Phys.*, 19: 1329 (1951).
4. J. E. Willard, Radiation Chemistry and Hot Atom Chemistry, *Ann. Rev. Phys. Chem.*, 6: 141-170 (1955).
5. T. J. Hardwick, The Effect of the Energy of the Ionizing Electron on the Yield in Irradiated Aqueous Systems, *Discussions Faraday Soc.*, 12: 203-211 (1952).
6. F. H. Krenz and H. A. Dewhurst, The Mechanism of Oxidation of Ferrous Sulfate by Gamma Rays in Aerated Water, *J. Chem. Phys.*, 17: 1337 (1949).
7. J. Dresner, Optimum Physical Factors for Rotation X-ray Therapy, *Brit. J. Radiol.*, 27: 340-343 (1954).
8. J. L. Haybittle, The Effect of Source Size upon Integral Dose in Teletherapy Units, *Acta Radiol.*, 42: 65-74 (1954).

DISCUSSION

CHAPTER 9

Hunt: The discussion on the four preceding papers will be opened by Dr. Raymond Quick, originally of The Middlesex Hospital, London, and currently of the University of Rochester, Rochester, N. Y.

R. Quick: Considering the last paper, that of Dr. Hayes, first, I have seen some curves, similar to those shown, in a previous publication [Am. J. Roentgenol., 75: 49-55 (1956)], and from the efficiency ratio they give the impression that a short distance would be desirable. Another question arising from these curves is whether the change in this ratio is due purely to the penumbra effect or is it related to the relative speed of rotation for different radii of movement.

Now, to go back to the beginning, I think that Dr. Roberts showed not the limiting but the desirable factors of moving-field dosimetry. He has shown something that many physicists realized before, that rotation really makes it, in many ways, a lot easier for us; whether this is also true for the therapist is another matter, and thus, excellent though Dr. Roberts's paper was, I do not consider that he established his subject.

The methods he mentioned for estimating dosage in rotation therapy are similar to some we have been using, but, since we want the residents to do a lot of this work, we have tried to avoid any mention of terms like $e^{-\mu d}$. The method we use is to apply the outline to the standard isodose curves in the usual way. Then, according to the depth of the point below the surface and the distance of the axis below the surface, a correction factor is obtained to apply to the depth-dose reading. Figure 1 gives the correction to be applied to standard 1.0-Mv 100-cm depth doses to allow for the varying target-to-skin distances. This correction factor is calculated from the F factor in the usual way. The figure looks somewhat complicated, but, in practice, it is very easy to use.

Another important point in rotation therapy is the necessity for accurate localization; I do not intend to imply that accuracy is not equally necessary in all other methods of therapy. Although I have had no ex-

perience with cobalt units, Dr. Simon showed some localization films obtained with his cobalt unit. Anyone who has not seen high-voltage films may be interested in Figs. 2 to 4. [These are reproduced, by permission of the author, from Radiographic Technique for Use with 1000-kv Therapy, by D. DiLella, X-Ray Technician, 25: 89-99 (1954).]

Figure 2 is an ordinary diagnostic film, and Fig. 3 is a 1 million volt localization film of the same patient. As can be seen, the localization at this stage is not particularly good, and the positioning will have to be changed to realign the markers on the front and back of the patient more exactly. The value of air in out-lining cavities and for localization at these energies is well known; this is illustrated by Fig. 4.

I think it would be interesting to review some of the things that were said on this subject three years ago (at the time of the Seventh International Congress of Radiology). One comment that seemed quite important was made by H. E. Johns, M. T. Morrison, and T.A. Watson on their experience with the Saskatoon Co⁶⁰ unit and was published in the proceedings after the last International Congress; this was as follows:

Radiation distributions obtainable with rotation are, in general, no better than for multiple fixed-field therapy, since the advantage of a somewhat lower skin dose is counterbalanced by the disadvantage of an increase in volume dose. In certain cases it might be simpler to set up a patient for rotation therapy than using several fixed fields, and under these circumstances rotation therapy might be considered an advantage.

... in most cases it is difficult to see how much advantage can be gained using rotation rather than fixed-field therapy for Co⁶⁰. The high percentage depth dose from Co⁶⁰ makes rotation less necessary than in the 200-kv region.

If one agrees with this, it seems that the only advantage of some of the newer machines will be the tremendous increase in the ease of positioning. I am interested in what other people think about this point.

To the physicist one of the most attractive features of rotation therapy is the fact that, instead of highly

discontinuous distributions, we find fairly smoothly varying functions that ought to be reasonably easy to deal with analytically. Of course, it is easy to do the first stage and to write down an equation for the depth dose at a given point, especially for high-energy radiation, but the integration is something else. Although it

detector mentioned today, namely, the oxidation of ferrous sulfate in aqueous solution. Actually, we measured the transmitted alpha-ray energy through the walls of a glass bulb.

We gave up the method for a number of reasons. First, there was a surface effect. We never knew what

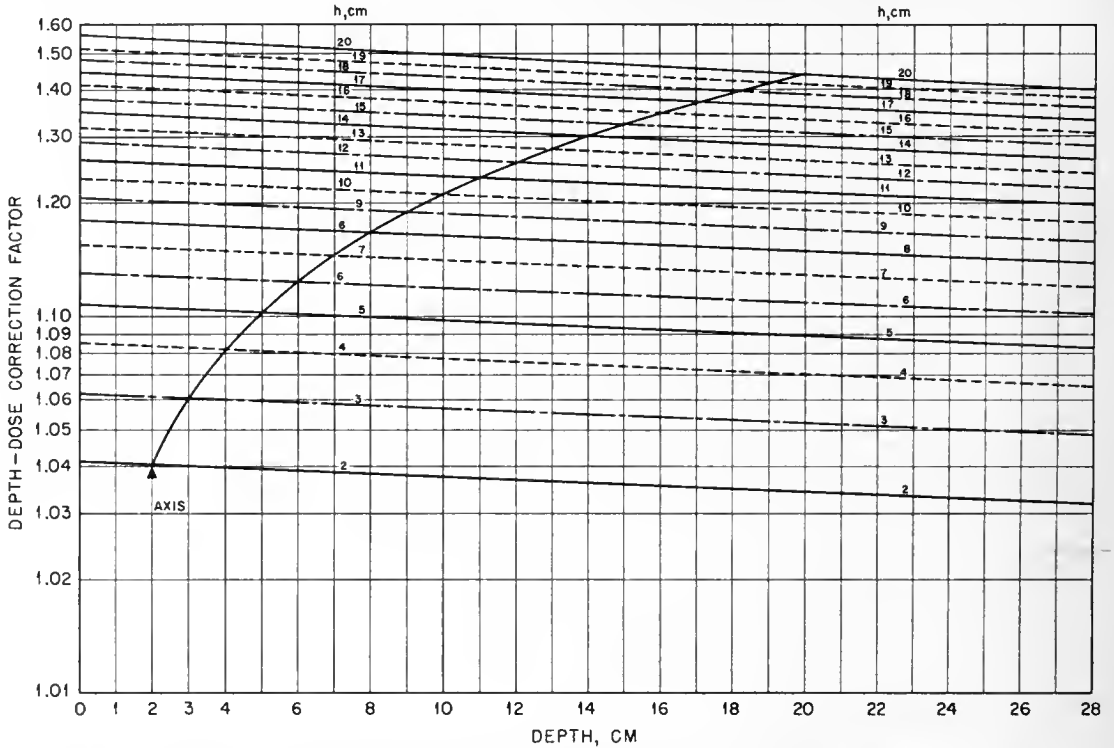

Fig. 1—Depth-dose correction factor for rotation therapy with 1.0-Mv X rays and target-to-axis distance of 100 cm. h , surface-to-axis distance; depth, depth of point below the surface (from point of entry of beam, parallel to the beam axis).

is difficult, if not impossible, to do this mathematically, it should be fairly easy with a simple analogue computer. Unfortunately, even simple analogue computers are expensive, but perhaps Dr. Brucer would be interested if he or his group has not already tackled this problem; I imagine that they have.

In Mr. Clark's results, I am interested to know whether he has any comparison with calculated values. All the results, I think, were measured.

Clark: I have none with me.

R. Quick: You have, no doubt, compared them with the calculated figures.

In one of Dr. Roberts's slides, I wondered—I think he pointed out that this was something that one would not do—what the advantage was of cutting out 60 deg in the middle of 140 deg. Why not use just two ports? It was just an example, I assume.

Roberts: Exactly.

Nurnberger: A word about chemical dosimetry. About 30 years ago, as a graduate student, I attempted to calibrate alpha-ray sources using the same chemical

the surface effect was, but it affected the chemical yield enough to make the method inaccurate.

Other chemical tests that we tried were discarded because some of the dyes changed color with age, perhaps because the solution was too concentrated for ferrous sulfate; the chemical yield was dependent upon the concentration. Furthermore, the oxygen content of the solution, the pH, and the surface condition of the bulb had some effect. I am wondering if Dr. Hayes has encountered these problems.

Broestrup: Dr. Guttman will discuss that question from a clinical point of view later.

I would like to mention that there has been an unfortunate tendency to think in terms of conventional X-ray equipment and X-ray dosage systems when dealing with rotating teletherapy equipment. I think that we should try to forget as much as possible about the design of X-ray machines and realize that we are dealing with an entirely new type of modality.

Dr. Roberts showed his dosage system, and it is almost identical with the one that we use at Delafield Hospital, New York, except that we are using scales instead of graphs.

Dr. Hayes made a statement about the relation between the source-to-skin distance (SSD) and the penumbra, and he pointed out that his statements related only to his particular equipment. I am afraid that some people still may get the idea that the longer the SSD the greater the penumbra.

This, of course, is not necessarily true; it is the ratio of the skin-to-diaphragm distance to the source-to-diaphragm distance that determines the penumbra.

Chalmers: From Professor Roberts and his group at

10 years, but we did show that molecules of β -carotene in hexane (it is almost pure hydrocarbon having low wave-length sensitivity) can be measured photometrically by a spectrophotometer set at 3100 Å. If any keen radiation chemist would care to take it up, he might find it useful for radiation dosimetry.

Loevinger: The first three speakers described three interesting, elegant, and useful methods of computing dose distributions for moving-beam therapy. In all three cases the procedure was to start with the actual



Fig. 2—Conventional chest film at 80 kv.

Middlesex Hospital, London, and from the Dublin group, I shall be incorporating two ideas in regard to the electronic rotational isodose computer (ERIC) Mark II. Professor Roberts does not like the name Eric. This happens to be one of his given names, and it is a very honorable one. Eric was the first Viking explorer of the North American continent, and this ERIC we hope will be an explorer of the fields of complex therapy.

With Dr. Hayes it is quite clear that the ferrous sulfate dosimetry is all right for high-energy radiation, but I am not pleased about the degradation by the Compton effect. When it is degraded below 400 kv by the Compton effect, does not the photoelectric effect come in?

I have done nothing in radiation chemistry for some

size and shape of the patient, decide on a suitable center of rotation, and then make a good computation of the dose distribution. It hardly need be said that the tumor does not respond any better for the dose distribution's having been computed. These procedures will be of value only if the results are available as a guide to the therapist before a final decision is made on the exact method of therapy. If many hours have been devoted to computing a dose distribution, one might anticipate a natural reluctance to decide that it must be scrapped and a new start be made.

The speakers suggested making the computations for patients as they came along and accumulating the dose distributions or casts, or both, for these individual patients. In time, they suggest, one would have on hand

a wide variety of results to serve as a guide for field planning on later patients. Instead of this procedure I would suggest that it might be better to produce systematically an atlas of dose distributions. Starting with a series of body sections for patients of different size, you mark on them positions of likely tumor occurrence

and terminate the SSD that is most practical and most economical. In a hectocurie unit the distance may be 40 to 50 cm. This prevents the use of very large fields, presents problems in providing a sharply collimated beam, and restricts rotation techniques mostly to parts of the body having narrow diameters, such as the head



Fig. 3—Chest film at 1 Mv using therapy tube (same patient as in Fig. 2).

and then compute the isodose curves for various field combinations. Suppose it takes half a working day to do one such distribution; then over a period of six months you would accumulate about 250 such dose distributions. The therapist would decide on the best treatment plan by comparing the patient with this atlas of isodose curves.

Extensive computations are not very useful on individual patients owing to the inaccuracy of the assumption that the perfect patient is made of water and every patient is perfect. The assumption behind the use of an atlas such as I have suggested is a little less extreme. Here the assumption is that the best dose distribution in a perfect water-filled patient is a reasonably good guide to the best dose distribution in a heterogeneous living patient, although the actual dose values are not the same.

Friedman: It will be necessary for us to establish a hectocurie teletherapy principle and a kilocurie principle. These principles will depend on the SSD or the source-to-axis distance (SAD). By the latter I mean that the roentgen flux of the teletherapy unit will de-

termine the SSD that is most practical and most economical. He elected to evaluate the efficiency of an apparatus on the basis of the integral dose. Having worked with the integral dose, I have found it not useful in determining the efficiency of an apparatus.

I wish to suggest the following index of efficiency of a supervoltage apparatus: It should be the distance between the 90 per cent dosage zone to the 50 per cent zone. I shall use the 90 per cent zone because it is often difficult to differentiate between the 100 and the 90 per cent zones.

What is the implication of this? Assume that we deliver a lethal dose of more than 8000 rads for a particular tumor and that the dose within the 90 per cent zone is 8000 rads. The 50 per cent zone would then receive 4000 rads. As we shall show later, 4000 rads is a common tolerance dose for normal tissues.

It is important that the distance wherein the dosage falls off from 8000 rads to 4000 rads be as short as possible so that the fewest possible adjacent normal structures will receive doses that exceed their tolerance. Therefore the quicker the fall-off, i.e., the

shorter the distance between the 90 per cent dosage of 70 to 90 cm and allows larger portals and better collimation and hence more efficient and versatile rotation techniques.

Dr. Hayes's curves have provided a large store of valuable information, and the conclusions derived from them will help us decide on a few standard distances. zone and the 50 per cent dosage zone, the more efficient is the treatment technique.

This index of efficiency, in addition to supplying use-

reasonably accurate dosimetry. This is assumed in a lot of film-badge dosimetry work. I expect to make my own measurements and evaluation soon.

Meschan: I think one has to be very careful about photometric determinations. We encountered some serious discrepancies in trying to relate photometric determinations to actual ionization.

Clark: In our case each film has its own density-roentgen curve. In other words, we place a couple of



Fig. 4—Localization film of larynx at 1 Mv using therapy tube.

ful information, takes into account the quality of radiation, size of portal, area of cross section of the body, integral dose, magnitude of penumbra, and number of portals employed.

The greatest efficiency is obtained with a sharply collimated beam of supervoltage radiation used with the rotation technique.

Meschan: In reference to the photometric determination that Mr. Clark was making, how accurately does it compare with the ionization determination?

Clark: I cannot give a critical answer. I have not made a critical comparison except on the basis of the work of Wilsey, which provides curves on the response of film with respect to different energies. Also, based on other published articles in the last few years, it looks as though cobalt energies are pretty safe for

Landsverk ionization chambers at spots where we also read the density; thus we calibrate each film. We do not have the standardization of development technique that is needed in order to reproduce the same film densities for the same roentgen values.

O'Foghludha: If rotation is limited to selected patients, there is ample time to carry out thorough calculations for each one. If it is used in all patients, some kind of standardization will undoubtedly be necessary; but whatever method is adopted must be capable of taking into account differences in effective (as distinct from true) dimensions, e.g., two patients who have identical outside dimensions may be extremely different inside.

Comas: Dr. Roberts has shown some isodose distributions that look like concentric rings around the center of rotation. Almost all are circular; some are

slightly elliptical in shape. We have plotted isodose distributions for a few patients under treatment. Since we have the time for it, we have tried different arrangements to see which one fits the tumor best.

We have observed — with the cesium machine, where there is considerable penumbra — that the 100 per cent line may be roughly triangular in shape, that there may be a hot spot in the center, and that the lines curve in the periphery. Thus the distribution of radiation in arc rotation, when measured in a water phantom, can have rather odd shapes.

The second point is that, when we plot these distributions, we assume this to be what happens inside the patient, although actually it is not. The danger lies in that we are misled into presuming to know things we do not know.

Lalanne: Dr. Roberts, in 250-kv rotation therapy, does distribution decrease sharply at the edge of the beam? This would not seem to be true with Co^{60} rotation therapy. This difference is due to penumbra. Do you know what the contribution of each of these factors is to the relative flatness of the distribution? In other

words, does elimination of penumbra change this distribution very much?

Roberts: Dr. Quick has special privileges. He had his training in radiological physics at Middlesex Hospital, London, and by tradition he has the right to say what he wants to say about us. I let Dr. Brucer down on the subject of the first paper. He gave me a subject about which I knew nothing. I was honest; I said that the only limitation I knew was that rotation-dose computations were difficult and complex and that the only thing to do about them was to try to simplify them. Concerning Dr. Quick's question on simplification, I can only say that in Great Britain a physicist is cheaper even than a resident.

I deliberately included in my talk one or two phrases that were intended to be provocative. I said once or twice, "We shall forget the patient," and Dr. Nurnberger nearly rose to the bait. I can assure you that in Great Britain, at any rate, the physicists see and investigate most patients along with the radiotherapist and are very conscious that they are not working with chunks of wax or water.

PART

APPARATUS AND SOURCES

2

**Section
C**

Machine Design

Marshall Brucer
(presiding)



Picker X-Ray Corporation Co⁶⁰ Teletherapy Machines

CHAPTER 10

D. T. Green

Picker X-Ray Corporation
Cleveland, Ohio

The Picker X-Ray Corporation has two basic models of therapy machine utilizing Co⁶⁰ sources. One is a machine originally designed to offer wide flexibility for fixed-beam therapy with some limited arc rotation. The other is a machine originally designed for rotational therapy but useful for fixed-beam therapy as well. Both machines use a wheel type shutter. A variety of possible shutters can be designed, each having advantages and disadvantages. Having had some experience with several types, I should probably favor a wheel type shutter, but this is a matter for some argument.

The basic difference between a shutter that fixes the source in the center of the head and a shutter in which the source moves is that, if the source is fixed in the center of the head, in the source-to-skin distance (SSD) you necessarily have some portion of the head; whereas, if the source moves, it is possible to have an arrangement wherein the bulk of the head does not intrude into the SSD.

Obviously, with the wheel type shutter the transmitted leakage when the beam is on would be higher if no provision were made to prevent it; however, there is no real reason why the required amount of shielding cannot be built into the bottom of the head to bring the transmitted leakage down to an acceptable figure.

The bulk of this added protective material will be less than the bulk of half the head since for beam-off leakage we are protecting to a considerably lower level than we need to do for transmitted leakage with the beam on.

Figure 1 is an over-all view of the Picker X-Ray C-3000 machine, "C" representing cobalt, and "3000," the rhm value for which the head is protected. In other words, this head will protect within National Commission on Radiological Protection recommendations a source delivering 3000 rhm.

It is important to keep clearly in mind that to specify that a head will hold so many curies is an incomplete statement; it is necessary to specify the output of the source for which the head is protected because the

output given by a stated number of curies varies considerably with the specific activity of the cobalt.

The C-3000 machine is a rather conventional design, having a vertical support for the head and a horizontal protruding member on which the head is pivoted on an axis situated above the level of the source. The axis of the beam and the axis of the pivot intersect; this arrangement offers some convenience in setting up.

The hanger, or yoke, that supports the head is pivoted about an axis parallel to the floor; this is a motor-driven movement. The entire carriage assembly that supports the head and yoke can be raised and lowered vertically by means of another motor drive. The head can be pivoted in the yoke by a handwheel, and the entire stand can be moved back and forth across a track laid on the floor. Another track built into the wall offers a horizontal movement convenient for fixed therapy and also makes it possible to use the machine as a rotational machine.

The collimator for this machine was designed and built under the supervision of Dr. Johns. Since someone else did it, I can say without prejudice that it is an excellent collimator. It is complete with beam-directing attachments, Manchester type pin and arc, back pointer, plastic compression cones, and distance localizer. The collimator can be rotated about the axis of the beam. It is basically designed for an 80-cm treatment distance, at which distance the field size can be varied infinitely from a square of 4 by 4 cm to one of 20 by 20 cm. Squares and rectangles can be obtained at will within this range.

Two knobs adjust the size of the field, one for each dimension of the field. Each bears a scale that gives the field size for that dimension.

Figure 2 illustrates how this machine is used for limited-arc rotation. The support for the head is coupled onto a rotation attachment situated between the rear of the machine and the wall of the room. This rotation attachment contains a motor-driven arm, which is pivoted at a point 43 in. above the floor; as the arm rotates in a vertical plane, it swings the

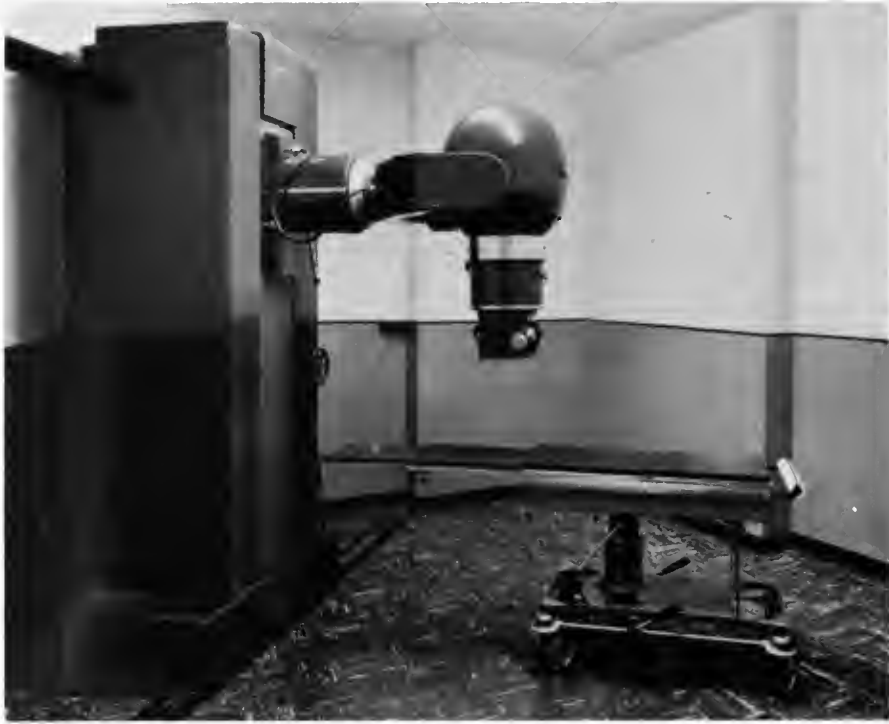

Fig. 1 — Picker C-3000 Co⁶⁰ teletherapy unit for a 3000-rhm source.

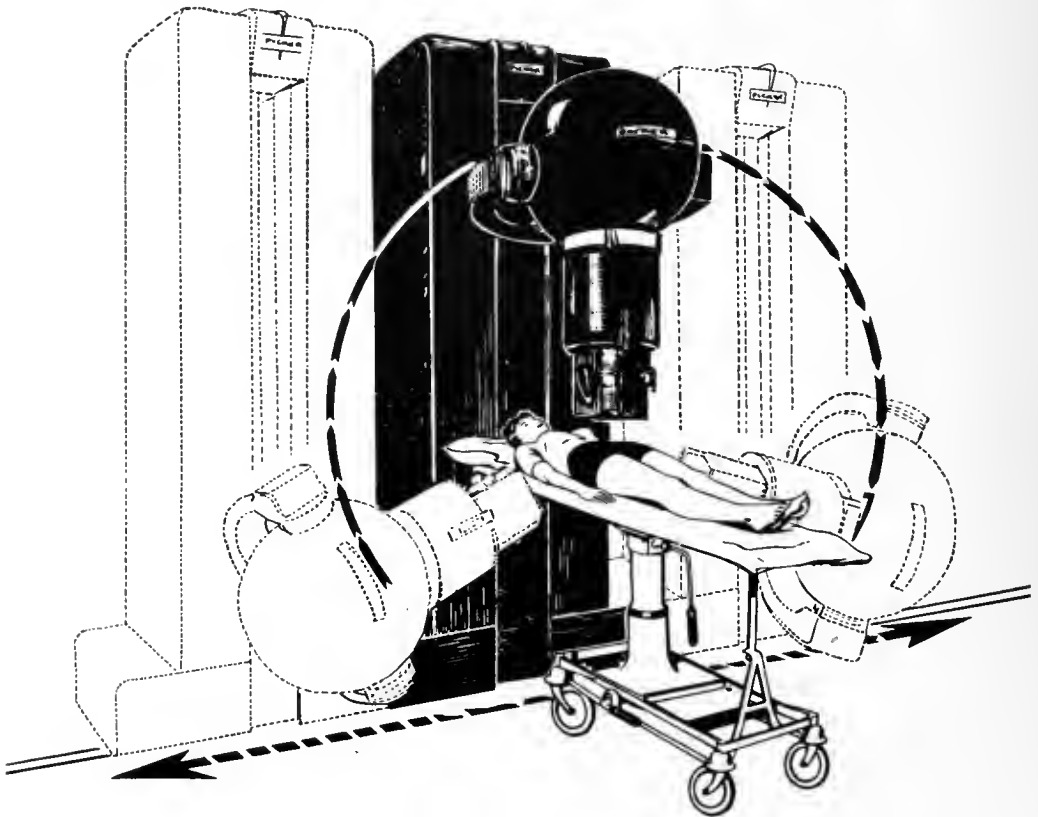

Fig. 2 — Limited arc therapy with the C-3000 unit.

treatment head through an arc, the entire stand moving sideways in the process, the axis of the beam always being directed toward the axis of rotation. We try to make sure that the machine is so adjusted upon installation that the axis of the beam does not deviate from the axis of rotation more than 1 cm. In practice most of them do not deviate more than $\frac{1}{2}$ cm, and thus the maximum error is 1 cm in directing the beam. The maximum arc that can be traversed is 240 deg.

Figure 3 is a sectional diagrammatic view of the collimator. The left side of Fig. 3 shows the collimator adjusted for the maximum field size, and the right side shows the collimator adjusted for the minimum field size. The adjustment is achieved by sliding bars in and out on a horizontal plane. These lie between bars fixed in position so that, when the collimator is fully opened, there is an almost solid lead cone confining the beam. Thus the transmitted penumbra through the collimator is least for large fields, while still remaining very low for small fields (less than 0.01 per cent of primary-beam intensity on the central axis).

The distance-localizing system consists of two lights, one on each side, which send rays of light converging to a point 80 cm distant from the source. This is an accurate system for distance localization and is very convenient.

There is a field illuminator, consisting of a light source and a 45-deg mirror, which projects a beam of light to outline on the patient the treatment field area.

Figure 4 is an over-all view of the other basic model that we produce. This is called the C-1000 machine because the head is designed to accommodate a 1000-rhm source. This amounts to about 1000 curies of Co⁶⁰ in a 2-cm-diameter source with a specific activity of about 26 curies/g.

This machine consists of a treatment head mounted on a yoke. In one model of this machine there is a primary radiation barrier; in another model it is supplanted by a counterweight, which nests in toward the stand and is out of the working area of the machine.

Figure 5 is a close-up view of the treatment head. The treatment head is pivoted on the hangar on a horizontal axis. A system of switches located at the rear of the head can be adjusted so that it is impossible to open the shutter unless the beam is to be directed at either the barrier or an adequately protected portion of the room. This permits the head to be rotated away from the barrier without the risk of accidental overexposure to personnel outside the room and allows the maximum possible versatility of the machine for each particular installation.

The collimator for this machine has a somewhat different construction from that of the Johns collimator. The principal objective was to make a collimator having a distal end as small as possible. We tried to trim down the amount of machinery in the area where the physician is trying to work. This collimator, when set for the smallest field size, is essentially a solid lead cone and therefore should give the least transmitted penumbra for small fields. This is contrary to the Johns collimator.

When the collimator is set for the smallest field, the size of the distal end is 11 by 11 cm. The smallest field is 2.9 by 2.9 at 40 cm treatment distance, and the largest field is 13 by 13 cm at the same distance. The field sizes are proportionately larger at 55 cm.

Figure 6 is a view of the collimator partially open for a larger field, showing a compression cone in place.

Figure 7 is a view looking up into the collimator. It can be seen that it is made up of a stack of lead plates, which interleave with each other as the collimator is opened and closed, adjusted by means of two knobs.

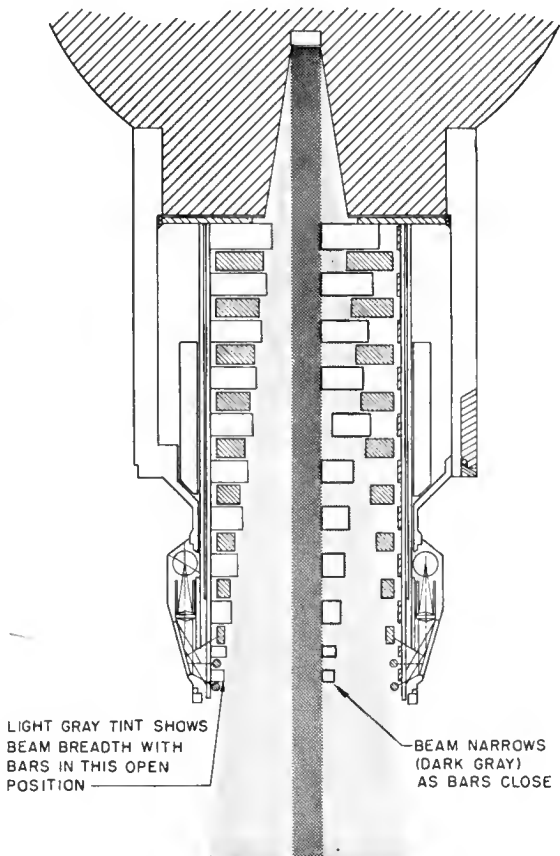

Fig. 3—The Johns-MacKay collimator.

The distance localizer is adjustable for treatment distances from 40 to 60 cm, a rather convenient arrangement. This can be used to measure treatment distance as well as to preset it and means that the machine can be used to plot the contour of the patient about the axis of rotation rather conveniently.

Figure 8 shows the field-localization cross hairs, which define the central axis of the entrance beam; the spot of light from the distance localizer, when centered on the cross hairs, indicates that you are at the distance shown on the scale of the distance localizer.

The effective protection of a given thickness of wall, ceiling, or floor increases in proportion to the angular



Fig. 4—Picker C-1000 teletherapy unit for a 1000-rhm source.



Fig. 5—Treatment head of the C-1000 unit.

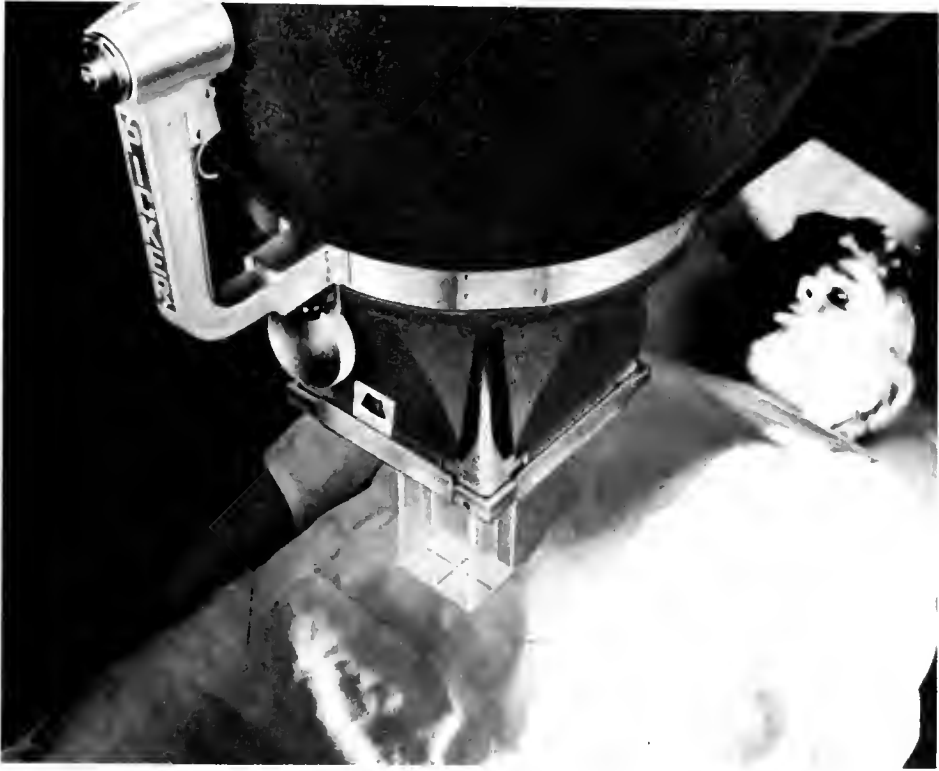

Fig. 6—Collimator with treatment cone of the C-1000 unit.

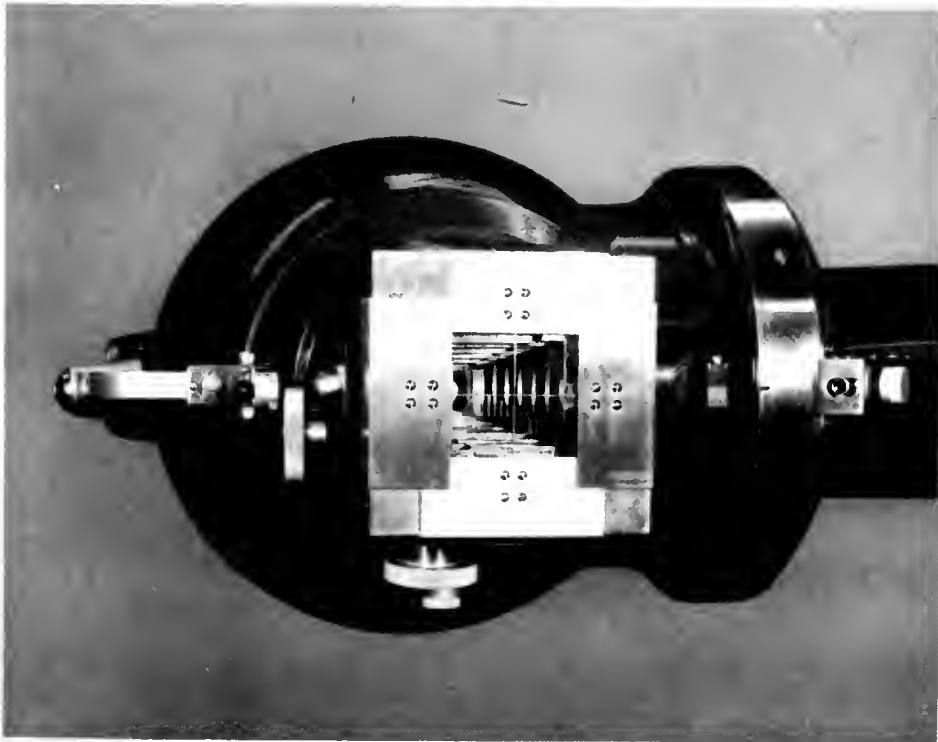

Fig. 7—Bottom view of C-1000 collimator adjusted for largest field size.



Fig. 8—Optical localizing technique with the C-1000 unit.

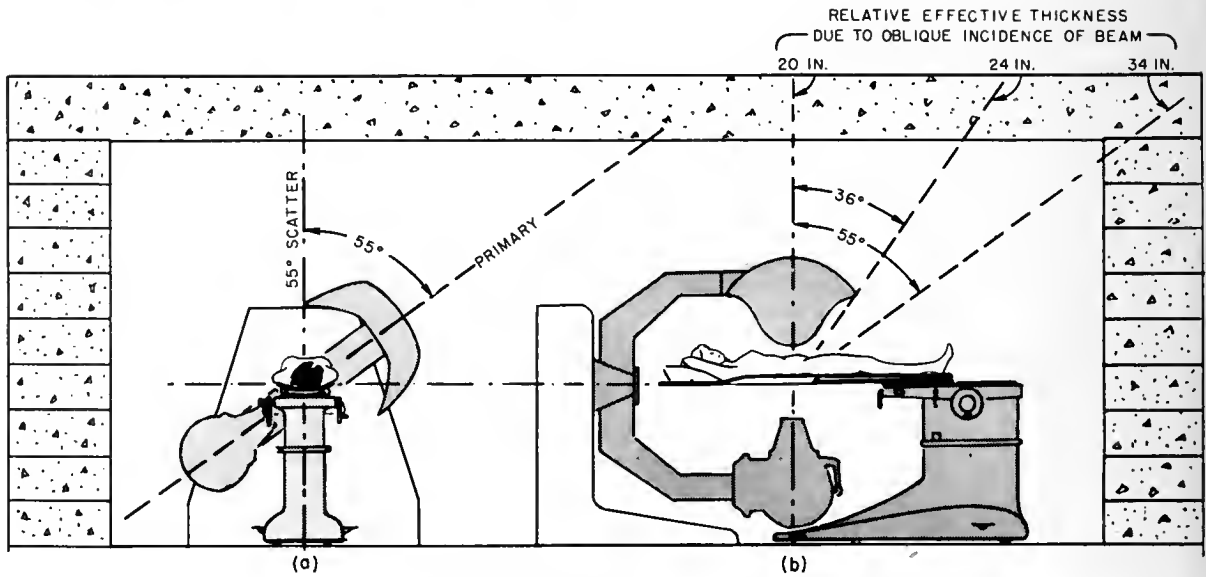

Fig. 9—Diagrams of the C-1000 unit and suggested shielding.

incidence of the impinging radiation beam. Therefore 20 in. of concrete is usually adequate to protect occupants of adjoining rooms. Figure 9 shows that the scattered radiation escaping the front or rear of the barrier always goes through the walls of the room at

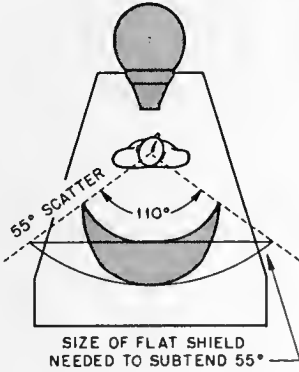

Fig. 10—The Picker Isocontour radiation barrier of the C-1000 unit.

an angle; therefore the length of the barrier is less than the width in order to make it as compact as possible and still give equal protection around the axis of the beam. From the side view of the barrier, it is evident that a 20-in. ceiling would be thicker than necessary for radiation scattered 55 deg in the plane at right angles to the rotation plane (oblique transverse thickness would be 34 in.). Because of this geometry the dimensions of the shield in this plane can be radi-

cally reduced, leaving more room for patient positioning.

The primary-beam absorber is so shaped that it will subtend up to 55 deg of scattered radiation on either side of the patient; yet the over-all width has been kept reasonable. This is achieved by tipping up the ends of the barrier, as shown in Fig. 10. The figure shows the compactness of the barrier compared to the size of a flat shield required to provide the same degree of protection.



Fig. 11—The control for the Picker C-1000 cobalt teletherapy unit.

Figure 11 shows the control that turns the machine on and off, times the treatment, and allows presetting of the speed of rotation for limited arc therapy.

Problems Related to the Use of X-ray Equipment

CHAPTER 11

Eugene Stober

X-ray Division
Westinghouse Electric Corporation
Baltimore, Maryland

Introduction

Since this seminar was scheduled too early for Westinghouse to disclose the details of their new design, I propose to discuss three problems connected with the use of X-ray equipment: (1) emergency procedure, (2) minimizing the hazard of leakage radiation, and (3) the clearance circle.

I will be very brief because recently I changed companies; therefore I must confine my comments to things that concern my own firm.

Under a study contract Westinghouse is exploring, among other problems, the possibilities of cost reduction from a standpoint of what can be accomplished in manufacturing, as well as trying to support room protection of the machine. Other features under study are a complete reevaluation of collimation equipment and the simplification of rotational machine controls. The Westinghouse machine will have two different treatment heads arranged in opposition; therefore the Oak Ridge Institute of Nuclear Studies medical staff can evaluate the advantages of opposed-beam techniques and the economies that may accrue from the use of two less expensive sources.

I shall discuss three relatively unrelated problems, emergency procedure, leakage radiation, and the clearance circle.

Emergency Procedure

In spite of all the safety devices that can be used, it is important to design a standard procedure for emergency action for the technician to follow in case the machine should fail to shut off. Because this situation leaves the patient in the beam, whatever is done to stop irradiation of the patient should be done with reasonable speed. The technician must be trained in advance for three successive emergency steps. It is presupposed that the control panel will be designed in such a way that the technician will have signal lights to show the position of the source or shutter. By re-

maining at the control at the end of treatment, the technician can be reassured that the source is turned off or the shutter has closed. It is important that technicians be taught never to assume that it will shut off but that they should always remain at the control to be sure it has shut off.

In the event the machine does not shut off, the technician's first step is to attempt to initiate turn-off at the control. Most designs have some kind of mechanical energy-storage safety device that will act in the event of an electrical failure. I propose that the technician be trained to kill the power supply by turning off the main switch and then turning it back on so that he has the use of the indicator lights. After this quick action he should be able to know instantly whether that source is going home. If the irradiation has ceased, the technician should not alarm the patient by telling him there has been a failure because it is not necessary that he know.

If step 1 fails, the technician should immediately proceed to step 2, which is to enter the treatment room and make one rapid attempt to move the source or shutter with a manual turn-off mechanism. It is presupposed that the design will have a manual turn-off mechanism that will be self-indicating, easy to reach, and fast. This step should be done very quickly.

If step 2 fails, the technician should immediately proceed to step 3, which is to remove the patient from the room as fast as possible, close the door, reassure the patient, and call the radiologist. From that point there is plenty of time for planning the remainder of the job of restoring the unit to working order.

If we could develop these three things that the technician could do in rapid succession, it would be an excellent emergency procedure.

Leakage Radiation

The second problem is to minimize the hazard of leakage radiation. We are dealing with an unusual type of radiant-energy device. It does not shut itself

off at the end of treatment; it merely hides itself and attenuates down to an acceptable level. Therefore we should train ourselves and all personnel who have occasion to enter or to work in the treatment room to have respect for this condition.

In the off position every machine on the market will comply with the National Bureau of Standards Handbook, but there is still hard radiation escaping at very low energy through the head. Therefore the following regulations should be established:

1. No person should ever enter the room unless he has business there.
2. Before entering, be sure the beam is turned off by looking at the signal on the control panel.
3. The technician, upon entering, should visually check the manual turn-off mechanism. It is presupposed that the manual turn-off mechanism, when the beam is on, will present some kind of red flag or obvious sign that you could quickly see upon entering the room.
4. Never touch the machine except for purposes of use or maintenance. The Handbook requires us to attenuate the radiation to an acceptable level at a certain distance from the source. Therefore the surface of the head is emitting radiation at a level higher than the Handbook permits. This is a function of the diameter of the head. Therefore one should get away from the habit of lounging on this treatment head, as is often done with X-ray equipment.
5. Stand away from the source shield. Distance is safety.
6. Minimize time spent in the room. Talking, thinking, and planning should be done elsewhere.

7. Persons who clean the room should be properly instructed.

8. Visitors should stand at a safe distance. It is rarely necessary to permit a visitor to examine the unit closely. The host should likewise stand at a safe distance. This gives him a better opportunity to describe the virtues of the unit and gives the guests a better view.

The Clearance Circle

The third problem in the design of a rotational machine is the clearance circle described by the end of the collimator. For a very large patient who has a tumor located off center in the body, the clearance circle necessary to provide clearance for 360-degree rotation is large. If such full clearance were provided, the collimator-to-tumor distance would be great, and penumbra would be excessive. It is apparent that isodose considerations save the day because, when a tumor is eccentrically located in a large body, it is best to treat it with a limited beam movement, entering through the thin side. Thus the distance from the distal edge of the collimator to the tumor can be held to as little as approximately 25 cm.

Obviously, all three problems deserve further work, and I hope they will be discussed. Another topic that I hope will be discussed is the trend toward the hectocurie machine. The hectocurie machine, as far as we in America are concerned, was born here at the Oak Ridge Institute of Nuclear Studies. Its success is a matter of record. I would like to hear comments on just how thoroughly it has captured the market.

Keleket-Barnes Cobalt Apparatus

CHAPTER 12

William L. Hansen

Keleket X-Ray Corporation
Boston, Massachusetts

Let us start by referring to Fig. 1, which shows the Keleket-Barnes source shield. The standard source capsule is mounted in a wheel, which is rotated 180 deg from the off position to the on position. This rotation is motor driven against a spring mechanism that turns the wheel to the off position in case of power failure. In addition, there is a shaft extension with an external handle which permits driving the source wheel toward the off position only.

At the bottom of the source shield is a chuck that will take all our collimating devices, the series of cones or the adjustable collimator.

The standard source shield has a 1000-rhm capacity, and, by replacing some of the lead close to the source with tungsten, the capacity is increased to 2400 rhm. The same external dimensions, the same source-wheel drive mechanism, approximately the same weight, and the same chucking arrangement for collimating devices permit standardization of the source shield. This source shield, with capacity of 1000 or 2400 rhm, can be used interchangeably with any of our mechanical supporting structures.

Figure 2 shows the source shield mounted in a fork of one of our supporting structures. Note the collimator mounted in the chucking device. The collimator includes a device for defining the beam by a light. A beta trap is built in.

Figure 3 shows the light source and switch, the two controls for the collimating blocks, and a view of the four interlocking blocks. These collimating blocks are as short as possible in the direction of the primary beam to permit treatment at short distances. They are segments of a sphere and are so interlocked that the beam faces are parallel with the outside edges of the primary beam. This is a unique method of reducing transmitted penumbra, and the design permits placing the patient as close as 34 cm to the source.

The slots cut into the blocks are for mounting extensions, which permit extending the farthest edge of the collimating device to a distance of 50 cm from the source. This reduces penumbra substantially when

treatment is desired at long distances. We call these extensions "Ubangi lips." The collimating surfaces of these extensions remain parallel with the collimating surfaces of the blocks in the collimator proper. Actual films taken show a substantial reduction in penumbra at 80 cm using these extensions.

Figure 4 is a photograph of a cobalt unit with two opposing source shields, each rated at 2400 curies. By means of the wheel-within-a-wheel mechanical structure and a very complex control, it is possible to place the two sources at any point over a large portion of a sphere. The diameter of the sphere can be changed by driving the source shields closer to, or farther from, the center. This device is the Spheray, now operating in the Veterans Administration Cancer Research Hospital, Chicago, under the supervision of Dr. Moss.

We do not anticipate a large demand for this extremely complex and expensive apparatus; however, it was built with the cooperation of the W. F. & John Barnes Co. We have learned much about simplification since this unit was designed, and we are now ready to take additional orders at a price of around \$200,000 each.

Figure 5 illustrates a ceiling-mounted type apparatus. The apparatus are shown in the inverse order of popularity. We have sold just one Spheray, a very few ceiling-mounted units, quite a few Rotarays, and many Floorstands. We expect the Floorstand apparatus to be eventually as common and popular as the present 250-kv X-ray therapy apparatus.

The ceiling-mounted equipment was originally hand driven vertically. Keleket has a policy prohibiting motor drives that move an object toward a patient. Keleket has adhered to this policy over the years and does not intend to change it. Much effort is needed to move the mass of a cobalt source shield and the counterbalancing weights; therefore a study was made to reduce the physical effort required to move the source shield vertically in this ceiling-mounted unit. The solution, which has been adopted for the ceiling-

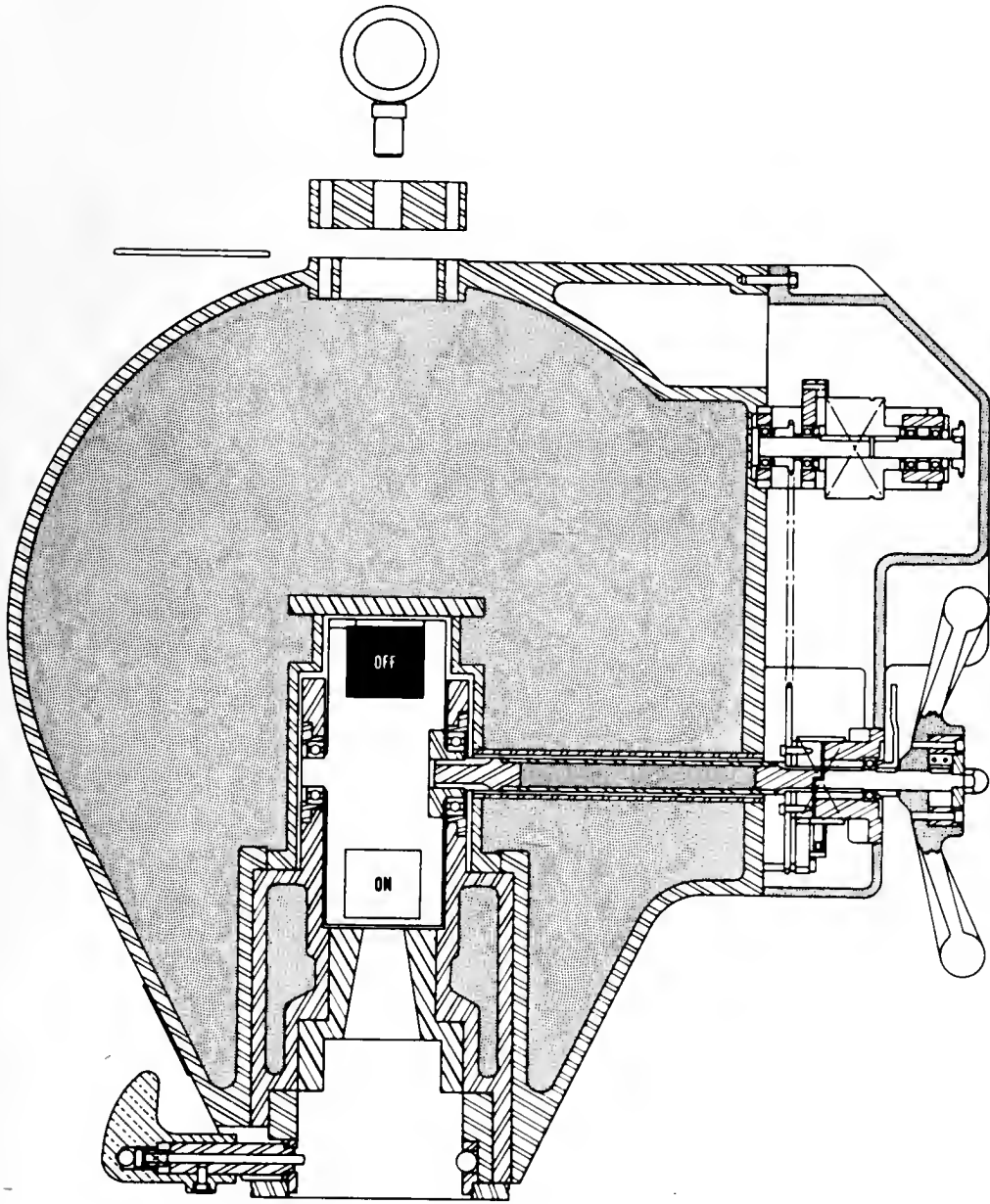

Fig. 1—Keleket-Barnes source shield.

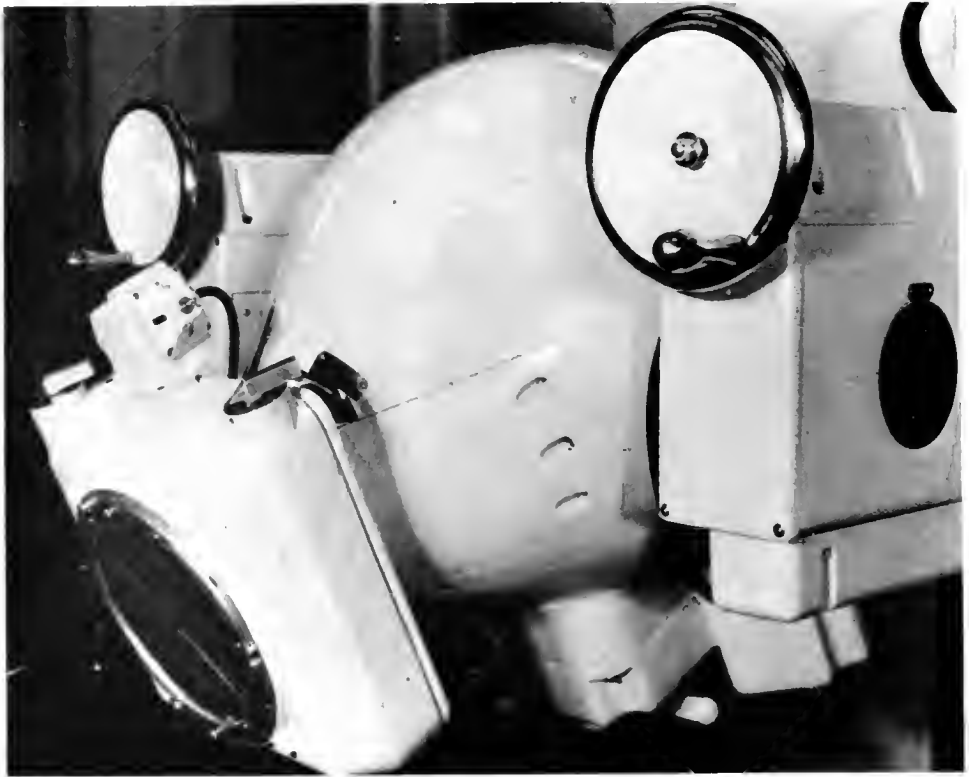

Fig. 2 —Source shield for collimator in yoke.



Fig. 3 — Variable collimator.

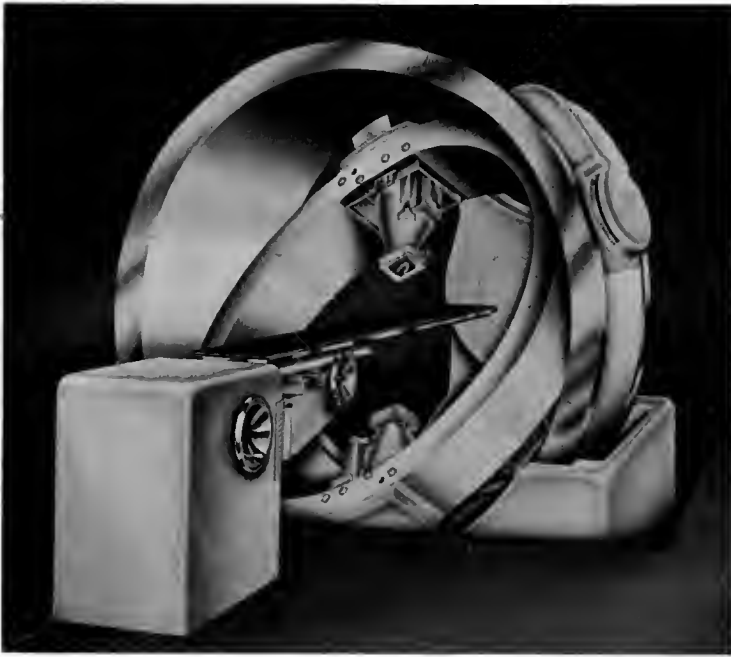

Fig. 4—The Spheray with two source shields.



Fig. 5—Ceiling-mounted cobalt apparatus.

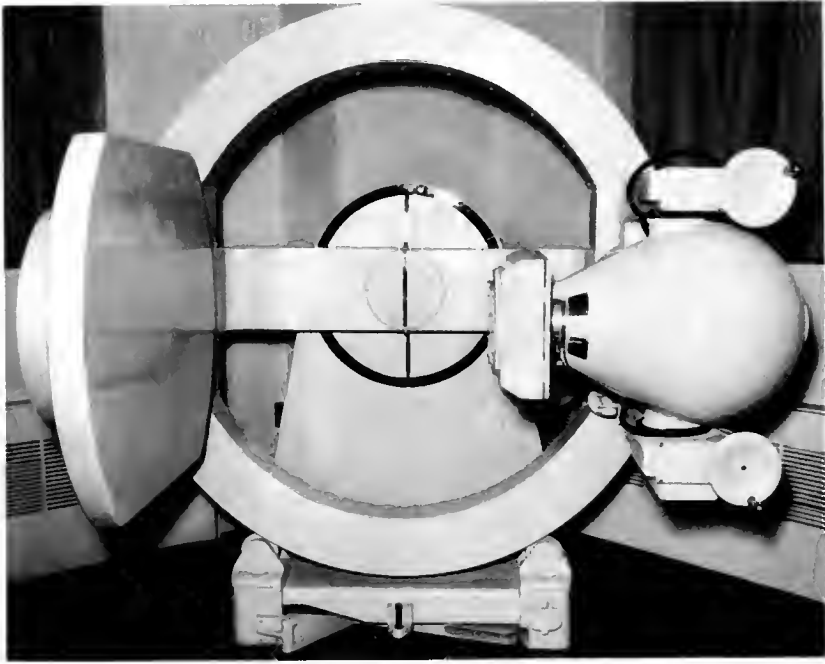

Fig. 6—The Rotaray with the primary beam horizontal.



Fig. 7—The Rotaray with rim counterbalance.

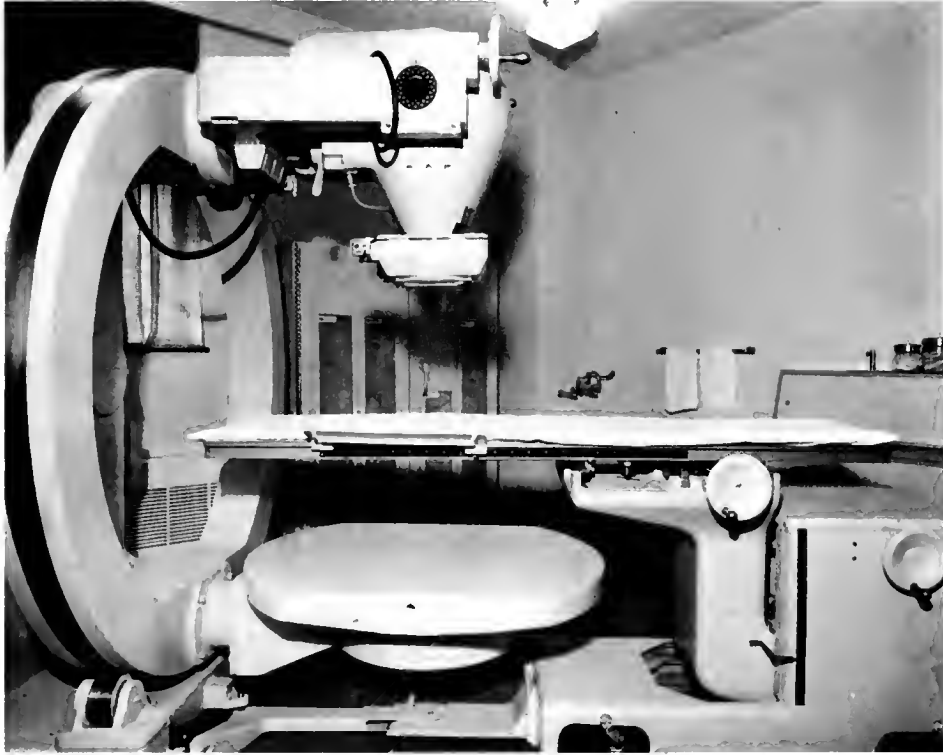

Fig. 8 — The Rotaray with treatment table in position.

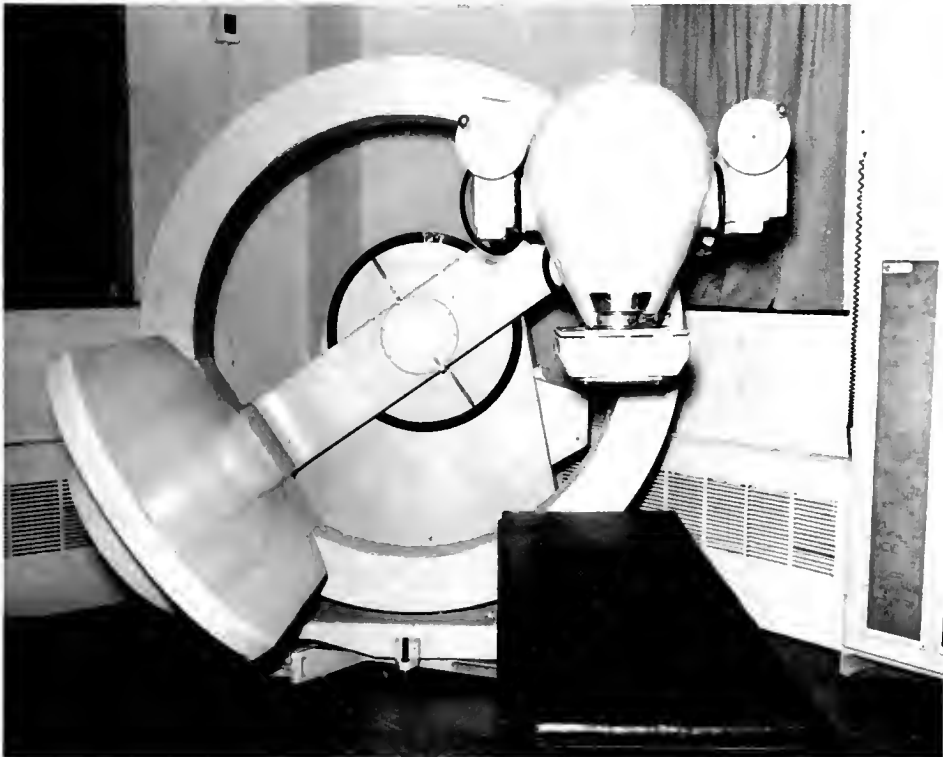

Fig. 9 — The Rotaray showing yoke rotation.



Fig. 10—The Rotary control.



Fig. 11—The Floorstand.



Fig. 12—The Floorstand showing shield angulation.



Fig. 13—The Floorstand showing shield angulation.

mounted apparatus as well as for the Floorstands, is a counterbalancing system that favors moving the source shield downward toward the patient; this is safe since gearing is involved which prevents travel unless induced by rotating the handwheel. A motor drives the source shield away from the patient and does the work of moving the unbalanced load.

We do not expect a great demand for the ceiling-mounted apparatus shown or a more complex ceiling-mounted unit that permits rotation of the ceiling platform. The cost is high because each one must be specially built.

Figure 6 is a head-on view of the Rotaray with the primary beam directed horizontally toward the primary-beam absorber. Where protection is adequate, a rim counterbalance can be used rather than the primary-beam absorber (Fig. 7). This eliminates the mechanical interference inherent with a primary-beam absorber.

Figure 8 shows the Rotaray with the primary beam vertical and the treatment table in position. The table is locked in position in relation to the base, and therefore reproduction of treatment positions can be easily obtained.

Figure 9 shows the rotation of the yoke supporting the source shield on the Rotaray. This yoke can be rotated a full 360 deg; thus it is possible to direct the primary beam in any direction in a plane going through the center of the primary-beam absorber. This is possible regardless of the position of the primary-beam absorber. The source shield can also be ro-

tated within the yoke. As an example, it is possible to rotate the source shield within the yoke so that the primary beam is horizontal with the ring and primary-beam absorber, as shown in Fig. 9. The primary beam would then be horizontal and parallel to the axis of rotation of the entire rotating structure.

Figure 10 shows the Rotaray control. This control permits a variation in rotation speed from 18 to 360 deg/min. Most Rotarays supplied to date have a limit of 720-deg rotation in each direction with automatic reversal. These Rotarays are also provided with means to obtain two arcs of beam interruption in each 360-deg rotation. Any arc treatment desired is also obtainable. Development work to permit continuous rotation and also to simplify our present mechanical structure and electrical circuits is under way.

The apparatus we believe will be the most popular is illustrated in Fig. 11. This is a view of the Floorstand apparatus. The forerunner of this apparatus was built for the Medical Division of the Oak Ridge Institute of Nuclear Studies by the W. F. & John Barnes Co. and is installed and operating at the Medical Division.

There have been a few modifications, mostly directed toward obtaining increased protection since protection requirements have changed.

Figures 12 and 13 illustrate the rotation of the source shield in the yoke. The source shield can be rotated so that the primary beam is directed straight upward.

Atomic Energy of Canada, Limited, Co⁶⁰ Teletherapy Units

CHAPTER 13

C. H. Hetherington

Atomic Energy of Canada, Limited
Ottawa, Ontario, Canada

Problems in Equipment Design

A discussion of the advantages or disadvantages of equipment, in the long run, has to be left to the radiotherapists and the personnel who are using the equipment. We have always made an effort to incorporate the features radiotherapists and physicists desire. We wish that we could design the machine to incorporate economically all the features that all the radiotherapists and physicists desire; however, such an apparatus might well cost a considerable amount of money.

As any manufacturer well knows, to add a special piece of equipment to a unit in production sometimes does not turn out to be too satisfactory because it may not do the job as well as was anticipated. The customer is not satisfied and we are not happy either. Therefore compromises must be made in design.

When design work commenced in 1949 on our first cobalt unit, the Eldorado model, very few data were available on cobalt absorption in lead and other metals, and very little information was available on the cross sections of cobalt metal for the production of Co⁶⁰. Since this was the first machine of its type, we had to get the thoughts of radiotherapists about what they might like. Since there had been no machine before this, it was difficult for them to give us concrete specifications.

We carefully calculated the amount of lead necessary to hold a certain source; we did this probably down to the smallest decimal and then added a half value layer (HVL) just to make sure. We also designed the unit with a radiation tolerance of 6.25 mr/hr on the surface of the machine because this was the permissible tolerance at the time. As a result, when the United States Atomic Energy Commission issued the new regulations of 10 and 2, the Eldorado unit could safely contain a source with as much cobalt as can be put in the International capsule of 100 curies/g of material. In other words, it can hold a source that gives about 150 r/min at 1 meter and still be within these tolerances.

Careful thought was given to a method of loading the source into the head in this original design. This was one of the most difficult problems facing us. We began with the basic assumption that we should not want to move the source once it was placed into the head; we then adopted the drawer system of loading sources through a diametrical hole in the head.

Since this source would have to be replaced, we designed a transfer case with two drawers, which operates in the following fashion: The head has a square hole through it, and the transfer case is similar; it has a two-drawer system, one drawer above the other. With the initial loading of the source, the transfer case is butted up to the head, and the drawer, complete with the source, is shoved into place in the head.

For source replacement the new source is shipped in the transfer case. This time the transfer case is raised until the drawer is in position. The old source is withdrawn, and the new source is pushed in. This can be done quickly and very simply on the site.

Diaphragming System

At the time we were doing this the National Research Council of Canada did some experiments on sloping-side and straight-side diaphragms. We designed the sliding-block type diaphragm based on their experiments. The four sliding blocks with two opposing blocks are operated by means of two handles, which gives an infinite variety of squares and rectangles on this particular unit, from 3 by 3 to 20 by 20 cm at 100 cm.

The Eldorado Unit

The Eldorado unit is floor mounted, and the source can move from 21 to 80 in. above the floor. The head can also rotate from 5 deg back of the vertical to 10 deg above horizontal in that plane.

As mentioned before, the Eldorado unit can hold a large amount of cobalt to give an output of about 100

to 150 r/min at 1 meter if the cobalt is available. At the present time, the highest specific activity available is about 50 curies/g.

The Theratron Unit

In 1949, Dr. Braestrup suggested the design of a straight rotational-beam therapy unit in which the head rotates in a 360-deg vertical plane above the patient. After consultation between our engineers and Dr. Braestrup, it was agreed that flexibility of motion, in both the equipment and the couch, would be most desirable for directing the beam and positioning the patient. It was also believed that it would be desirable to have the couch an integral part of the equipment. To accomplish these objectives of maximum flexibility, the convergent-beam irradiator, the Theratron, was designed. The movement of the source is so controlled that it can be positioned anywhere in the surface of an equatorial band of a sphere having a horizontal axis; the beam is always directed to the center of this sphere, which is the center of rotation of the unit. In this unit, the distance from the source to the center of rotation is 75 cm.

These source movements are accomplished by 360-deg rotation in a vertical circle above the patient; as seen from the side, the machine can rotate at an angle of about 40 deg in this plane, which is at 90 deg to the vertical circle.

The following conventional movements are possible. Straight rotation with varying speeds can be used, and limit switches can be used to reverse the direction of the motion at both ends of a predetermined arc. In other words, the equipment can cycle between two points with the shutter open. A 360-deg rotation with limit switches can be used so that the shutter will open only over a predetermined arc. The oscillation movement can be used to tilt the beam from the vertical to some desired angle, together with any of the above-described types of rotation.

The couch can be adjusted and offers linear motion in three mutually perpendicular axes. The counterweight on the unit is directly opposite the head and acts as a shield for the primary-beam irradiation.

The source housing is a combination of lead and tungsten. In this unit it is desirable to keep the dis-

tance from the source to the bottom of the unit as short as possible in order to keep the clearance from the bed to the base of the equipment, mentioned by Mr. Stober, as great as possible.

The shutter system on the Theratron is a moving-block type, which is pulled back by an air system to expose the source. It opens against a double helical spring, and then, when the air system is shut off, it automatically closes.

The same general type diaphragm used in the Eldorado model is used on the Theratron, but the blocks are made of tungsten because of the clearance problem. Cones of various types can be attached to the base of the diaphragm for different treatments.

The Theratron Junior Unit

The need for a smaller, or hectocurie, unit has been evident for a long time, and the Theratron Junior was designed in an attempt to fill this need. This unit was designed such that the source can be shipped in the head. This, plus the fact that the unit can be plugged into an ordinary outlet, makes installation relatively simple.

The source can be moved through 360 deg about a horizontal axis. The couch is an integral part of the equipment. As seen from above, the couch can rotate through 180 deg in this plane. It can be moved so that it remains parallel to some initial orientation.

Concerning the movements of the source, straight rotation in a vertical circle above the patient or cycled rotation over any preset arc, i.e., back and forth, can be accomplished. For fixed or multiportal therapy various positions of the couch and head can be used in combination. The unit is designed to hold a source that will give approximately 50 r/min at 55 cm, which is the distance from the source to the center of rotation. This requires about 1000 curies of cobalt.

The shutter system is a moving-block type, the same as that on the Theratron; it is actuated by air pressure. The block moves against the spring, which is closed when the unit is turned off. This will give rectangular fields to a maximum of 15 by 15 cm at 55 cm.

Nuclear Engineering, Limited, Gamma-ray Teletherapy Units

CHAPTER 14

Stephen Stein

Nuclear Engineering, Limited
London, England

Introduction

Having had some years of experience in the design and manufacture of equipment utilizing radioactive sources for the purpose of gamma radiography and research in chemical engineering and having assisted in the production of a few of the early simple units used for radiotherapy, we decided that one logical step in the development of the activities of Nuclear Engineering, Ltd., was to consider the design and production of therapy units suitable for use with sources of strengths up to thousands of curies of Co^{60} . In general, two lines of approach were open to us. We could either produce, with the aid of consultants, one or two standard models that would attempt to meet the requirements of a majority of therapists or, alternatively, adopt a policy of building a number of different types of units to individual specifications. A number of reasons led to the latter approach.

From widespread discussions with therapists and physicists in the United Kingdom, Europe, and elsewhere, it is obvious that there is no general unanimity of opinion either on the most desirable type and size of source for any given application or on the salient features of equipment for gamma radiotherapy. There are, however, some points that are in general accord with the ideas of nearly all users and manufacturers. A unit should provide adequate shielding of the source both in the operative and in the nonoperative positions, be robustly constructed, require the minimum of servicing, and permit exchange of source safely and without difficulty. Its operation should be simple and straightforward.

Each of the foregoing points has received careful consideration by all manufacturers, including Nuclear Engineering, Ltd. Our final approach to the problems is somewhat different from that of others.

From the standpoint of protection, we have decided upon a maximum intensity of radiation at a distance of 5 cm from the surface of our units of 6.25 mr/hr measured in air with the source in the shielded position. This value is considerably lower than the level

accepted by many manufacturers, and it has been set by us for two principal reasons: First, certain eminent therapists have indicated that it is a very satisfactory limit to achieve, considered from the protection point of view. It corresponds to a working time of 48 hr/week, ignoring occupancy factors etc., and will result in a very low mean dose rate to medical personnel.

We have looked upon the maximum permissible weekly dose of 300 mr not as a design figure but as something to be avoided by as wide a margin as possible. Second, we have been further influenced by several suggestions received from various quarters that this maximum may be reduced in the future.

The establishment of a limit of intensity of radiation near the surface of the unit when the source is in the operating or exposed position is rather more difficult. For those units in which the source is retained within the main body of the storage head, we have aimed at a maximum dose rate not in excess of 1000 times the fully shielded dose rate. For those units in which the source is propelled into a subsidiary treatment head, the radiation level is closely related to the specified performance of the beam-shaping device, i.e., variable diaphragm, collimator, or applicator.

For the kilocurie units used with a variable diaphragm, the over-all transmission factor of the diaphragm blades has been set at a maximum value of 0.25 per cent. One consideration involved in the fixing of this limit is illustrated in Table 1. Column 1 gives the various values of the percentage of transmission through a variable diaphragm (maximum treatment field, 15 by 15 cm); column 2 gives the percentages of the total integral dose received by a patient outside a treatment beam 5 by 5 cm.

Because of the degree of shielding our therapy units are sometimes considerably heavier than their counterparts produced by other manufacturers. However, since a high standard of workmanship and robustness has been demanded, this is not considered to be a disadvantage. The saving of not more than 10 to 15 per cent in weight does not materially affect the costs

or influence the performance of a piece of equipment custom built with the emphasis on quality.

Table 1

Diaphragm transmission, %	Body dose, %
0.25	2
0.5	4
1	7
2.5	16
5	28
10	44

Concerning the requirement for a minimum of servicing, it would be a great and an unnecessary waste of time to discuss in detail all the design features of each of our units, but one comment may not be out of place here. In general, the amount of servicing required by any mechanism is a function of its complexity; hence simplicity should be the keynote of design. One common source of complexity arises in the gear train usually associated with an electrical drive. In some units, such as the Cobaltron II treatment head, described subsequently, we have eliminated this component by making the moving member carrying the source in the form of a drum that is itself the rotor of an electric motor.

Another particular feature of our equipment is the mounting of the source at the end of a bar of shielding metal that can be extracted from the head into a transport container and vice versa either by means of an auxiliary attachment (Cobaltron II) or by using the exposure mechanism of the head itself (Cobaltron I).

Concerning the mode of operation of radiotherapy units, most manufacturers provide similar basic controls in the form of indicator lights, interlock switches for various purposes, exposure timer, etc., and Nuclear Engineering, Ltd., provides no exception. Exposure of the source in any of our units is by remote electric control only, after closing of all interlocks etc. Before exposure the source is automatically mechanically locked in the shielded position. Power failure merely results in normal shielding of the source by the spring-return mechanism. Failure of the spring mechanism is overcome by provision for reversal of the electrical drive, and, as a final emergency measure, the source can be shielded by a manual-control operation that results in locking the head against further use before inspection.

After these general remarks concerning the background of our activities in the field of radiation therapy, the following descriptions provide an indication of the manner in which we have responded to various requirements.

Our most recent Co⁶⁰ therapy unit is the Cobaltron I. The specification for this arose from the desire of a distinguished European center to have a unit that could be useful at one and the same time for both short-distance and general teletherapy.

Many treatment centers have now had many years' experience with short-distance treatments of tumors

lying not too deeply in the body; they use 10 g or more of radium, and recently some have modified their radium apparatus to work with up to about 50 curies of Co⁶⁰. There is therefore a great deal of useful work that can be carried out with a source of this size, and this consideration led to the request for a two-source unit.

Cobaltron I Storage Head

The degree of protection provided by the Cobaltron I storage head (see Fig. 1) is such that up to 500 curies of Co⁶⁰ or its equivalent can be housed without the intensity of radiation at a distance of 5 cm from the surface of the head exceeding 6.25 mr/hr when the source or sources are in the shielded position.

Two separate sources can be contained in the head, each being attached to a long bar of shielding material. These bars are situated side by side in two channels that pass through the center of the storage head. When not in use, both sources lie close to the center.

Each bar holding a source is attached to a flexible drive actuated by an electrical mechanism situated at the rear of the head. By means of this drive mechanism either source can be pushed out of the shielding provided by the storage head and through a shielded tube into the treatment head. Automatic selection of the source to be used is made by aligning the shielded tube with either source channel by a simple slide movement.

To expose either source, the appropriate disk is rotated electrically through one quarter revolution, and the source is pushed forward by the drive mechanism into the exposure position in the treatment head. Except in emergency, movement of a source is always controlled from a remote-control panel.

Source exchange is effected safely by transferring a source, together with its shielding bar, into or out of a transport container by remote control. To achieve this, a transport container is aligned with the shielding tube, and the source and its shielding bar are pushed into the container by means of the normal exposure drive mechanism.

Treatment Head

The treatment head is a block of heavy metal attached to the storage head by the shielded tube through which a source is pushed when an exposure is made. Two treatment ports are available. The first is directly in line with the source tube and provides a maximum aperture of 8 cm diameter at a source-to-skin distance (SSD) of 10 cm. The second treatment port is at right angles to the source tube and provides a maximum aperture of 7 cm diameter at an SSD of 7 cm. This aperture can be rotated through 360 deg around the source tube.

An advantage of having a detachable treatment head is that an alternative design to suit special requirements can be easily substituted.

Beam shaping is carried out by means of rotatable applicators.

The applicators are so designed that the intensity of radiation outside the useful beam at a given distance

The head is provided with a motorized rotation within the yoke. The yoke itself can be rotated about the vertical axis of the telescopic tube.

Although it is possible to balance the head and yoke

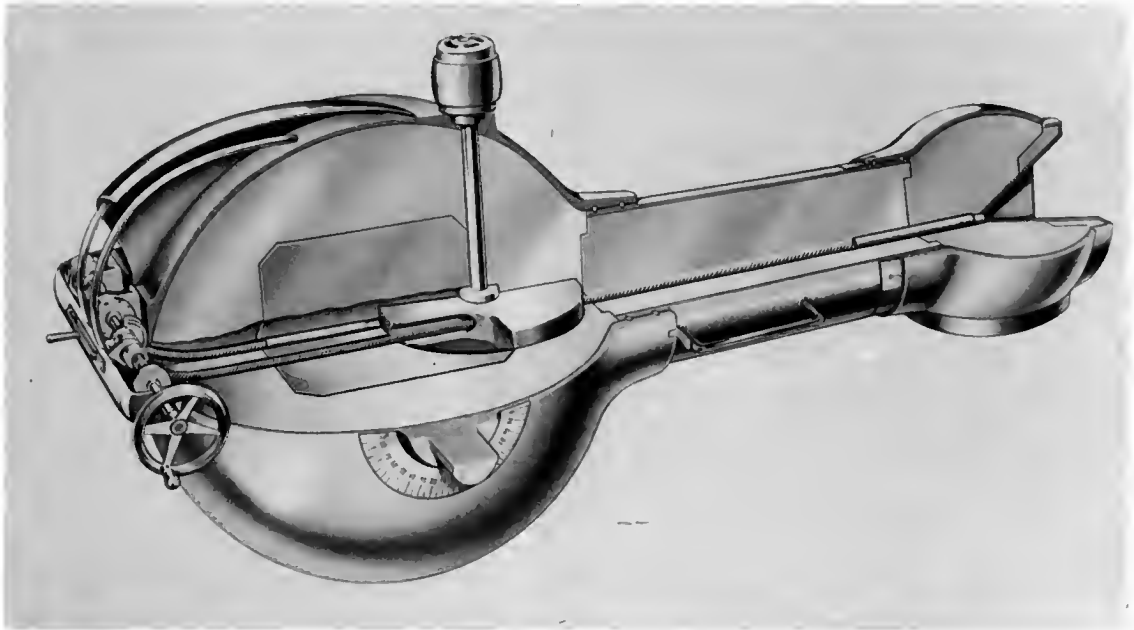

Fig. 1—Schematic sectional view of the Cobaltron I therapy unit.

from the source does not exceed 0.6 per cent of that on the central axis of the beam at the same distance from the source.

In general, with the particular head described the minimum treatment distance would not be less than 10 cm plus any air gap that is considered necessary to reduce skin reaction due to electron contamination.

The inner beam-defining surfaces of the applicators are heavily plated with copper to attenuate secondary-electron emission.

Provision is made for light-beam positioning by a special lamp attachment that can be inserted into the aperture not being used for treatment. The filament of the lamp coincides with the center of the source when in the exposed position, and electrical interlocks are provided so that it is possible to expose a source only when the lamp has been removed and a shielding plug has been inserted into the aperture. Rotating fittings are provided for the attachment of a back pointer or other mechanical device to the treatment head.

Mounting

The storage head is mounted in a yoke carried at the lower end of a telescopic tube. This tube is usually mounted on the ceiling (Fig. 2) and provides motion in the vertical direction. The head and telescopic tubing are supported by a counterweight carried on a chain, and the head is raised or lowered by means of a motor drive on the chain.

sufficiently to allow for manual movement control, we have motorized all the motions because it is desirable, when setting up a patient for close-distance treatment, for the radiologist to be near the treatment head to see clearly what he is doing. Under these circumstances a handle adjacent to the yoke trunnions may be awkward to reach, whereas a small push-button control held in the hand is quite convenient.

Angular scales graduated in degrees are provided for all rotary motions, and adjustable limit switches are also provided to restrict the orientation of the gamma-ray beam for protection purposes, e.g., the presence of an insufficiently shielded space adjacent to the treatment room.

Remote-control Panel

A gamma-ray source can be exposed only from the remote-control panel (Fig. 3), which comprises the usual items, locked power relays, indicator lamps, exposure timer, start button, emergency stop button, audible end of exposure signal, and synchronous clock.

Sets of three colored indicator lamps (green, amber, and red) are provided to show whether the source is shielded, moving, or exposed. These can be repeated wherever required, e.g., on the treatment-room door. Two other lamps indicate which of the sources has been selected for use. The green indicator lamp does not light until all appropriate interlock switches have been closed and the unit is ready for use. Interlocks can be incorporated as required for various purposes.



Fig. 2—Ceiling mounting of the Cobaltron I therapy unit.

One is always provided so that no source movement can be actuated from the remote-control panel while setting up of a patient is being carried out.

Exposures are started by means of a push button and are normally terminated automatically by operation of the time switch. An emergency push-button



Fig. 3—Cobaltron remote-control panel.

Operating Sequence

The patient is positioned and the prescribed treatment beam is set up. All interlock switches, e.g., on the treatment-room door, are closed. The required treatment time is set on the exposure timer. The starting button is then pushed.

control that overrides the timing device and causes immediate return of the source is also provided.

As mentioned previously, an exposed source is automatically returned to the shielding position in the event of breaking of interlock switches, power failure, and switch-off.

A direct-acting manual return is also provided on the treatment head for use in emergency.

Cobaltron II

Head and Diaphragm

The design of the kilocurie Co^{60} therapy head, Cobaltron II, was made to a specification demanding that, in the first instance, its use with a source of the order

Source and Light Pencils

As in the Cobaltron I, the source is contained in a long pencil of heavy metal (Fig. 6), which, instead of being attached to a linear-drive mechanism, is set parallel to the axis of rotation of a cylindrical drum. A similar pencil carrying a small powerful electric lamp is mounted diametrically opposite to that carrying the source. The position of this lamp is so arranged that, on rotation of the cylinder through 180

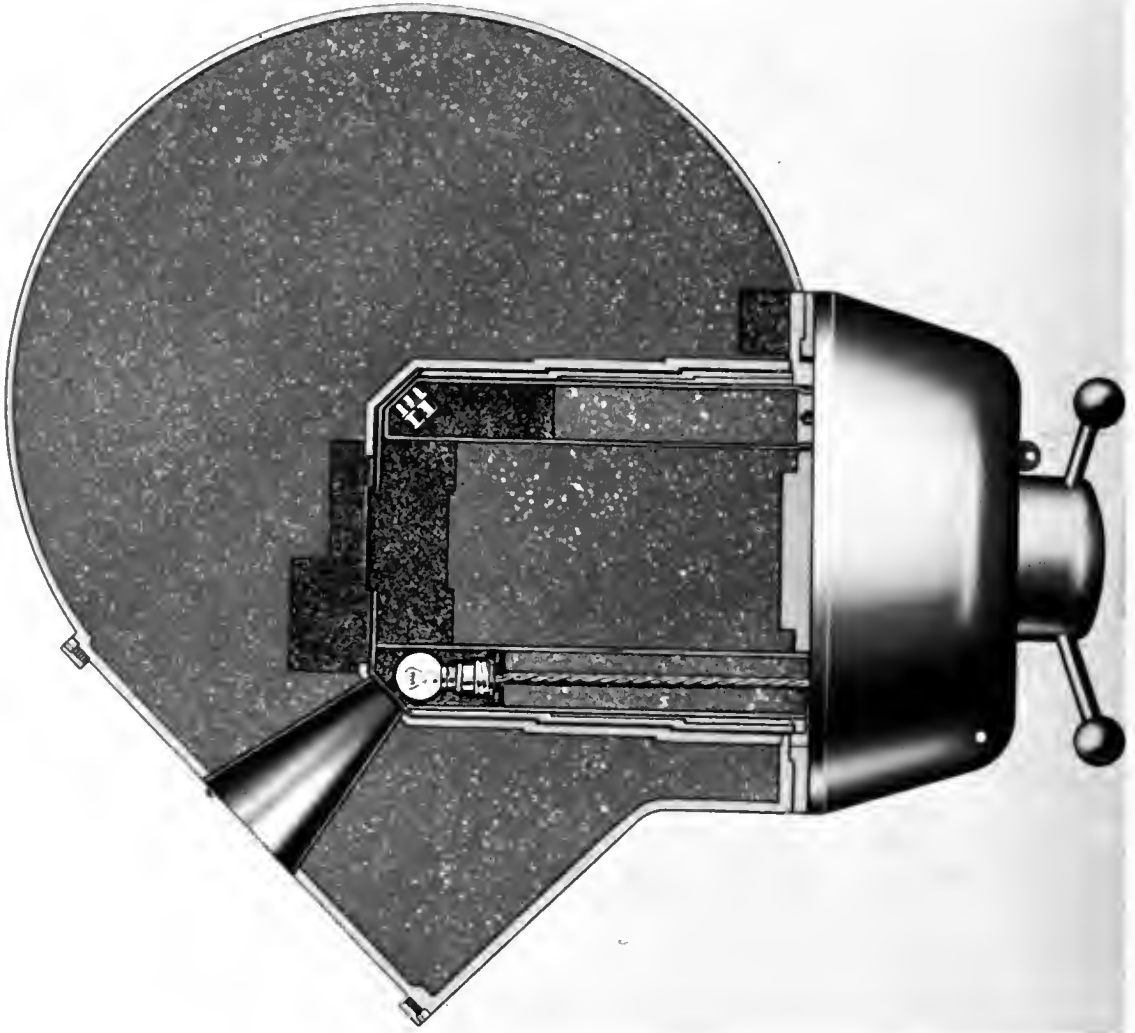

Fig. 4—Sectional diagram of Cobaltron II.

of 300 to 400 curies of Co^{60} be possible and that large fields at an SSD of only 40 cm be possible when a variable diaphragm is used. The protection required, however, was for ultimate use as a 2000-curie unit (Figs. 4 and 5).

The Cobaltron II head can be mounted on the normal upright type of gantry (Stabilatron I) or on a telescopic ceiling mounting (Stabilatron II). Alternatively, it can be used on the familiar rotating floor-mounted stand with a direct-beam shield as counterweight (Mobaaltron).

deg, the small filament takes up the position previously occupied by the center of the source.

Source Exposure, Shielding, and Exposure Termination

To expose the source, it is brought from its shielded position to a point immediately in front of a conical aperture in the head by rotation of the drum through half a revolution. To end an exposure, a reverse half turn is made.

Shielding of the source is achieved by the use of lead and heavy metal encased in steel. The surfaces of all interior moving parts are stepped in the usual

normal operation is by means of a push button and an electric timing switch.

Termination of an exposure is carried out by a



Fig. 5—Cobaltron II head and diaphragm.

manner to minimize the leakage of scattered radiation.

As in Cobaltron I, exposure of the source can be carried out only from the remote-control panel, and

spring mechanism that will also return the source to the shielded position in the event of a power failure or breakage of interlock switches. In an extreme case of failure of both motor and spring-return mechanisms,

the source can be closed by turning a handle situated at the rear of the drum mechanism, in which event the head is automatically locked against further use.

The electric-control circuits incorporate all the features described previously for the two-source unit, Cobaltron I.



Fig. 6—Cobaltron II source and light pencils.

Source Removal and Replacement

To remove or replace a source, a transport container (Fig. 7) is aligned with the head, and the isotope pencil is withdrawn by means of a cable attachment. This operation can be performed by remote control. A movable cylinder of shielding material is so arranged to reduce considerably the flash intensity occurring when the source is in transit between the head and the transport container. A new source is loaded in the same way.

Diaphragm (Model A)

Shaping of the gamma-ray beam emerging from a conical opening in the head is accomplished by a diaphragm consisting of sets of overlapping blocks of heavy metal so arranged that the two dimensions of a rectangular beam can be adjusted independently. This diaphragm (Fig. 8) was designed to provide large treatment fields at relatively short SSD since it was to be used initially with a source of only 350 curies. Rectangular treatment fields in the range 0 by 0 cm to 15 by 20 cm at an SSD of 40 cm are provided (model A). (By using the more compact model B, rectangular fields up to 15 by 15 cm can be obtained at an SSD of 50 cm.)

The entire diaphragm assembly can be easily rotated through 180 deg and locked in any desired orientation. Two built-in dials indicate the dimensions of the aperture, and a large circumferential scale graduated in degrees enables the rotation setting to be read. The size, shape, and center of the gamma-ray beam are indicated on the patient's skin by means of the light beam emerging from the treatment head.

Standardized fittings are provided on the casing of the diaphragm for the attachment of such accessories as the back pointer, pin and arc, filter, and mechanical SSD scale. In conformance with our standard prac-

tice, the design of the treatment head is such that the intensity of gamma radiation at a distance of 5 cm from the surface does not exceed 6.25 mr/hr with a source of 2000 curies of Co^{60} in the closed position.

Outside the useful beam the intensity of radiation at the surface of the diaphragm does not exceed 0.25 per cent of the full beam intensity.

Movement Control

When used in conjunction with a floor-mounted gantry (Stabilatron I), the following typical movements can be controlled either from a mobile pedestal or from a hand grip: vertical rise and fall of not less than 160 cm motorized at 60 cm/min and reversible motorized rotation of the head within the yoke and about the horizontal supporting arm. A manual horizontal movement of 30 cm parallel to the supporting arm can also be provided.



Fig. 7—Cobaltron transport container.

Mobaltron I

The familiar rotating mounting with treatment couch is also available (Mobaltron I, shown in Fig. 9). This incorporates most of the usual characteristics of this type mounting, together with the following two additional features.

The distance from the source to the rotation center can be varied from a minimum of 60 cm to a maximum of 90 cm. The adjustment of this distance is motorized at a speed of about 30 cm/min, and an adjustable interlock is provided so that rotation is possible only at one predetermined distance.

The Cobaltron head can also be rotated within its yoke at a speed of the order of $\frac{1}{8}$ rpm.

Remote-control Panel

A desk type remote-control panel is normally supplied with the Cobaltron II head. This incorporates the

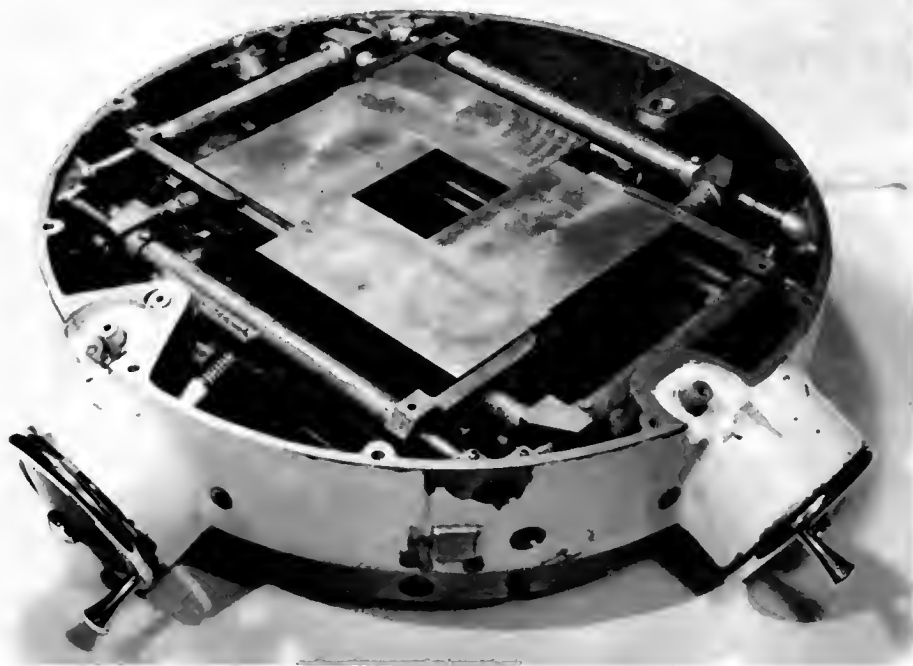

Fig. 8—Cobaltron II diaphragm (model A).

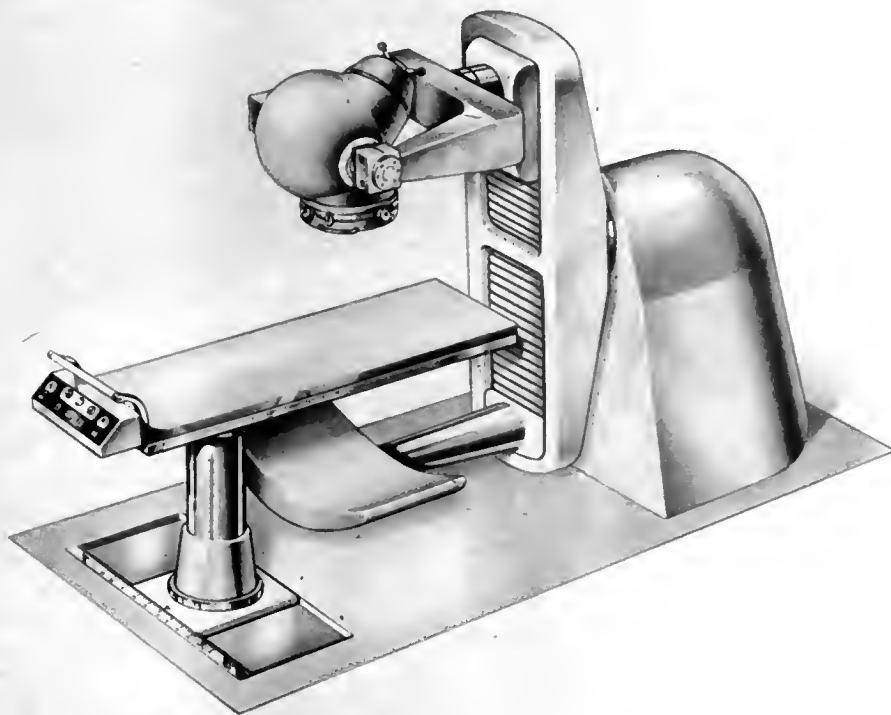

Fig. 9—Mobaltron I.

same features listed previously for the Cobaltron I. With a rotating mounting, extra controls are provided where necessary.

Stabilatron II Ceiling Mount

To meet the requirements of a leading London hospital, which requires a moving-field facility in a very long,



Fig. 10 — Stabilatron II ceiling mounting.

narrow room, an installation is at present in hand which consists of a telescopic ceiling mounting providing horizontal and vertical motion (Fig. 10). These motions will be interlinked with rotation of the treatment head in its yoke in such a way that an arcing motion can be carried out over a maximum angle of about 270 deg. The radius of rotation will be variable between 80 and 110 cm, and the speed of arcing during treatment will be 2 deg./sec.

Convertron I

Use of Cs^{137} is now being seriously considered in radiotherapy, and Nuclear Engineering, Ltd., is actively engaged in this development. Work is in progress on

units for kilocurie strengths and also for smaller sources, e.g., Convertron I (Fig. 11), which is fundamentally similar to Cobaltron I and is intended principally for short-distance treatment, such as treatment of the head and neck.

The unit consists of the storage head, treatment head, mounting, and remote-control panel.

The degree of protection provided by the storage head is such that a source of 50 curies of Cs^{137} or its equivalent can be housed without exceeding the surface dose mentioned previously.

The source capsule is designed to hold single, e.g., 1 by 1 cm, or multiple source pellets and can have an over-all diameter of up to 3 cm. The source characteristics of this unit are therefore very similar to those of a 20-g radium unit. The capsule is attached to a cylindrical bar of shielding material which runs in a channel through the center of the storage head; when not in use, the source is retained close to the center of the head.

The mechanical design features and controls of this unit are basically the same as those for the Cobaltron I but are simplified for use with only one source.

The treatment head is approximately spherical in shape with a diameter of about 23 cm, not including casing and mechanism, and weighs approximately 130 kg.

Source exchange is effected by transferring the source, together with its shielding bar, into or out of a transport container by means of the normal exposure mechanism.

The applicator nozzle consists of a block of heavy metal attached to the storage head by the shielded tube through which the source is pushed when an exposure is made. Two conical treatment ports are provided in the nozzle, one at an angle of 60 deg to the axis of the tube and the other at 30 deg. Alternative angulations of the treatment ports can be provided. The two treatment ports are identical and provide a maximum field of 50 cm² at a distance of 5 cm from the source.

Beam shaping is carried out by means of rotatable clip-in applicators providing rectangular and circular fields of various sizes and at various SSD's up to the previously mentioned maximum size. These are so designed that the intensity of radiation outside the useful beam at a given distance from the source does not exceed 0.6 per cent of that on the central axis of the beam at the same distance from the source.

As in the other units, provision is made for light-beam positioning, and fittings are provided for the attachment of standard types of positioning aids.

The storage head is supported in a large bearing mounted in a yoke that is carried at the lower end of a telescopic tube and allows the head and applicator nozzle to be rotated about the nozzle tube as the axis. The complete unit is supported by a counterweight carried on a chain and is raised or lowered by means of a motor drive on the chain.

The head bearing is provided with manually controlled rotation within the yoke, and the yoke itself rotates about the vertical axis of the telescopic tube.

The storage head and its mounting are sufficiently light and compact to enable them to be mounted on many of the 250-kv X-ray gantries in use at present. Conversion of an X-ray unit to gamma-ray therapy is then relatively simple.

ma radiotherapy. Our present thoughts may be summed up as follows: There is no clearly defined demand for any particular size of source nor for an apparatus having any particular set of characteristics; therefore we are prepared to consider all individual re-

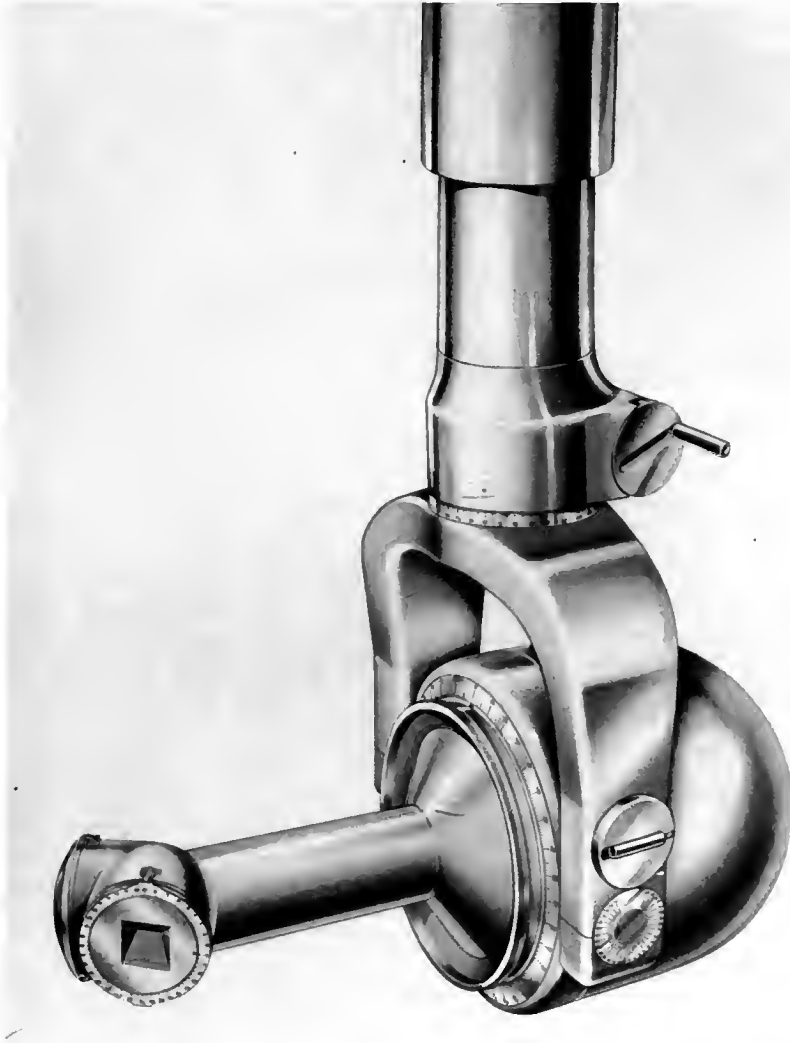

Fig. 11 — Convertron I cesium therapy unit.

Summary

We have attempted in the foregoing remarks to give some indication of our approach to the problems involved in the provision of suitable apparatus for gam-

ma radiotherapy. Our present thoughts may be summed up as follows: There is no clearly defined demand for any particular size of source nor for an apparatus having any particular set of characteristics; therefore we are prepared to consider all individual re-

Teletherapy in Japan

CHAPTER 15

Hirotake Kakehi

Chiba University
Chiba, Japan

For gamma-beam teletherapy we have been using Co^{60} machines for three years in Japan. Recently we have also obtained betatrons, but as yet we have no super-voltage X-ray machine for teletherapy.

I would like to introduce to you some of the Co^{60} machines that are made and used in Japan at present. We have three types: First is the 20-curie machine. It is used chiefly for therapy of the head and neck. The source can be brought into the machine from the lead storage box by using an air-shutter mechanism.

Then there are the 100- to 200-curie machines. Figure 1 shows the outside view of the 100-curie Co^{60} machine of a stationary type. The roentgens per minute at 30 cm from the source is about 20. The leakage of the gamma rays outside the machine at 1 meter from the source is about 10 to 15 mr/hr. The thickness of lead of the head wall is about 15 cm.

Figure 2 shows the same machine as seen from below with a good view of the shutter. The maximum field size at 30 cm source-to-skin distance is 10 by 10 cm.

Figure 3 is a sketch of the inside of the head. The size of the source is 1 cm in diameter and 2 mm in thickness. The capsule is shaped like a clover leaf.

The effective diameter of the source is about 2.3 cm. The sources can be moved between on and off positions by a motor-driven rotating wheel.

Figure 4 shows another 100-curie machine. This is simpler than the preceding one, but the efficiencies are almost the same.

The machines shown in Fig. 5 were also recently made in Japan (Tokyo Shibaura Electric Co., Ltd.). Figure 5a shows the machine used for 200 to 400 curies, and Fig. 5b shows that used for 1000 to 2000 curies, which can be used for rotation therapy. The source size is 2 cm in diameter, and the international capsule is to be used.

In Japan at present more than 10 of these machines are used in the university hospitals or cancer hospitals; generally speaking, the curiage is rather low compared with that of the machines in the United States.

Gamma-beam teletherapy has several advantages, such as less skin reaction, less radiation sickness, and higher depth dose, compared with therapy by conventional 250-kv X-ray machines. Therefore in the near future the Co^{60} machines will be used more in Japan for teletherapy.

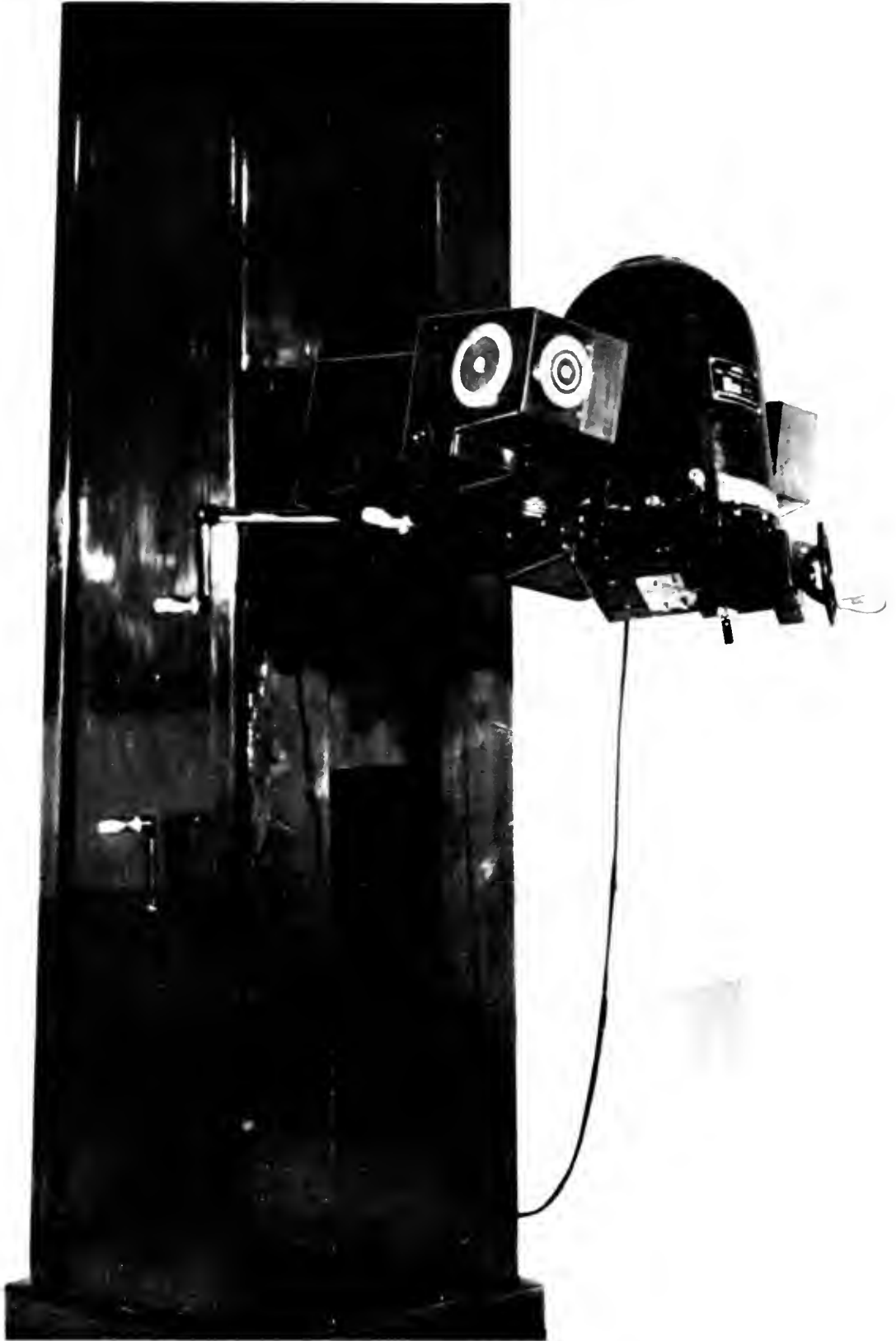

Fig. 1—Stationary type 100-curie Co^{60} machine.



Fig. 2—Stationary type 100-curie Co⁶⁰ machine as seen from below.

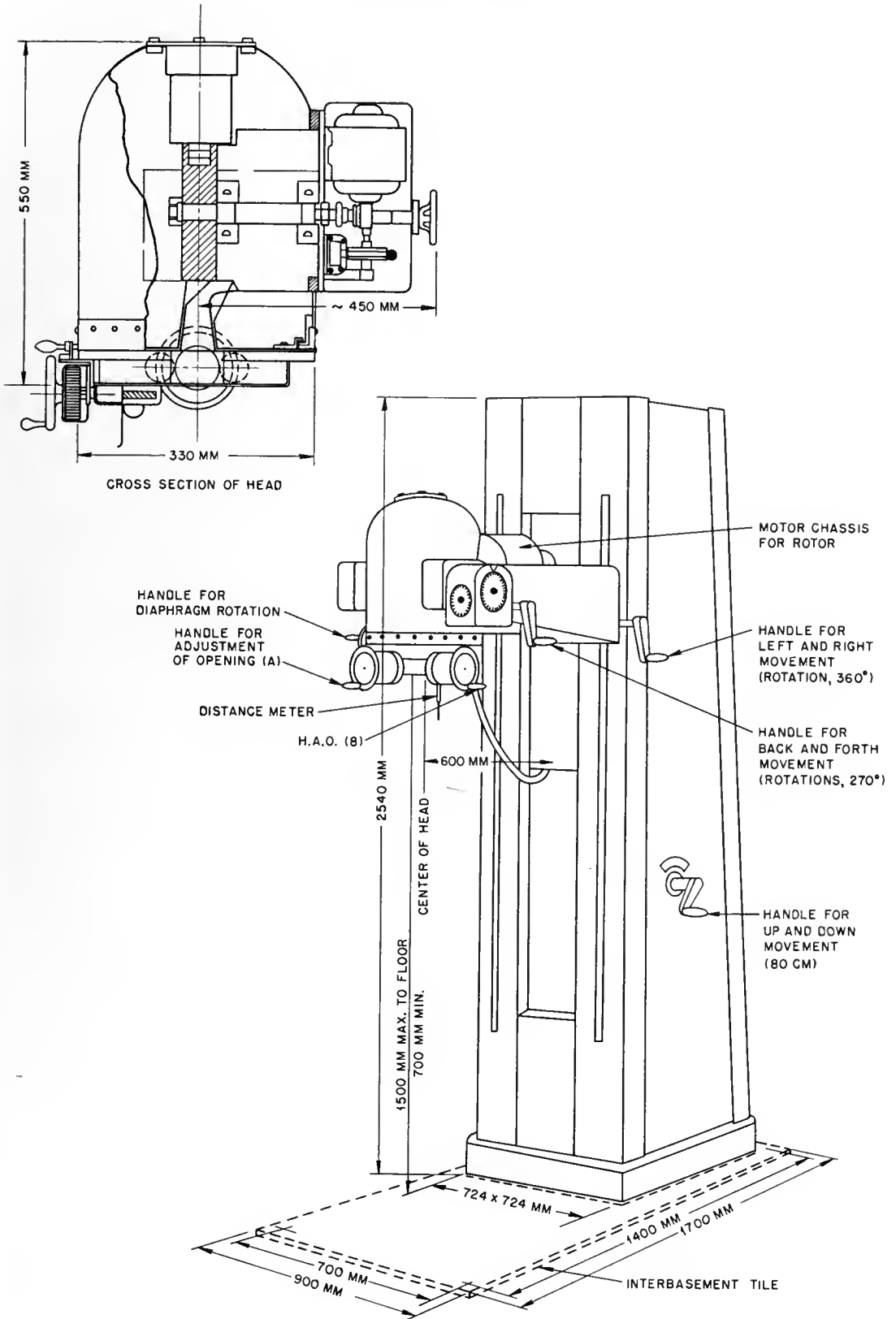

Fig. 3—Sketch of the inside view of the head of the 100-curie Co^{60} machine shown in Figs. 1 and 2.

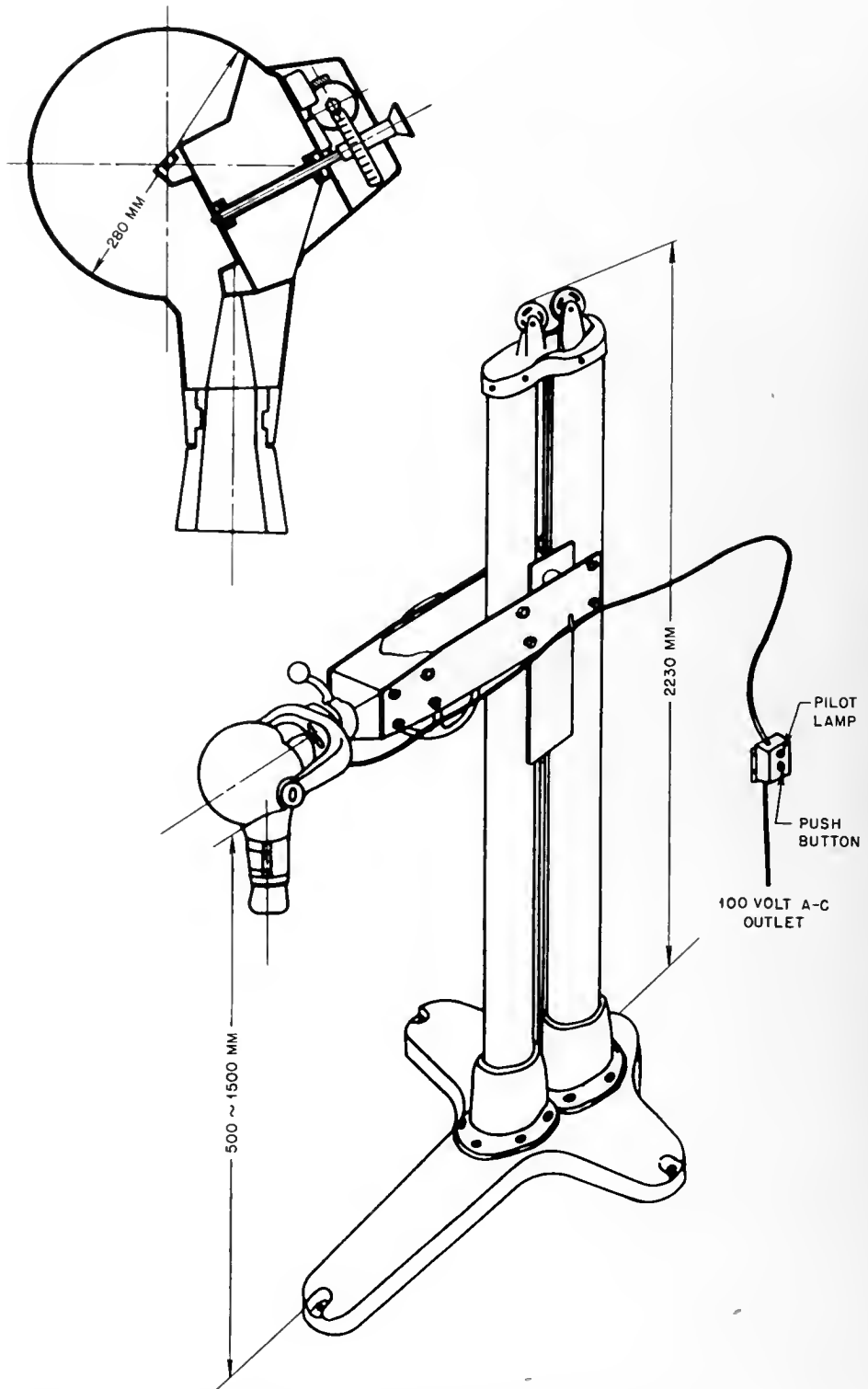
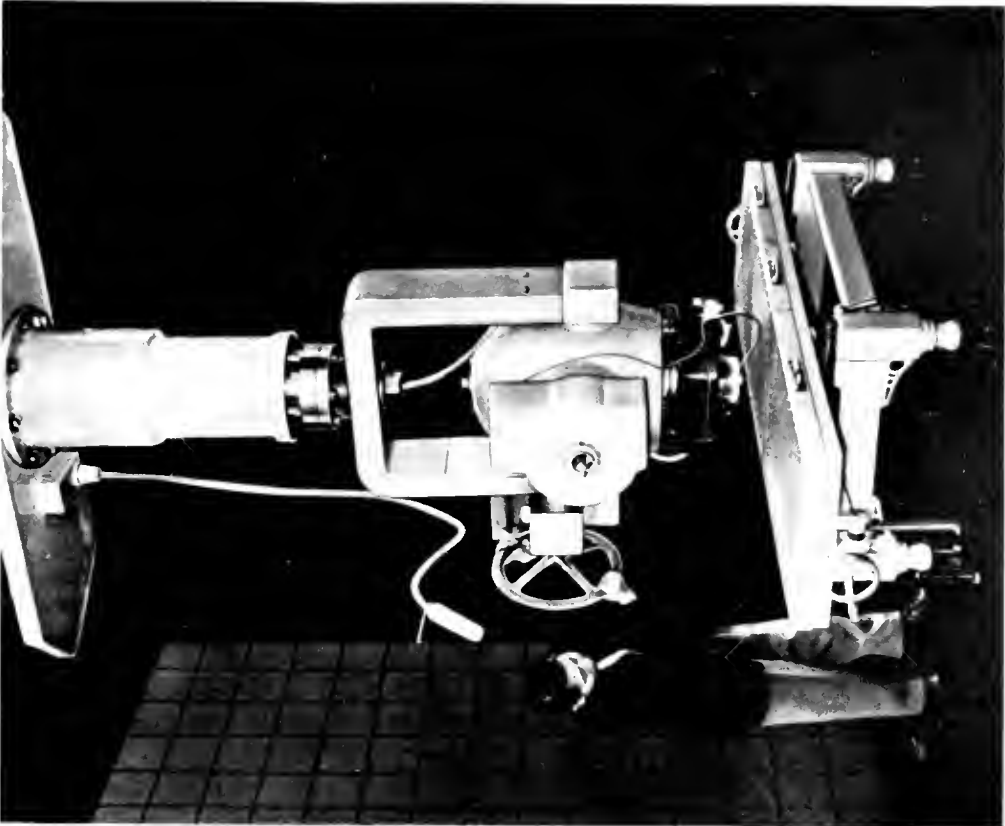
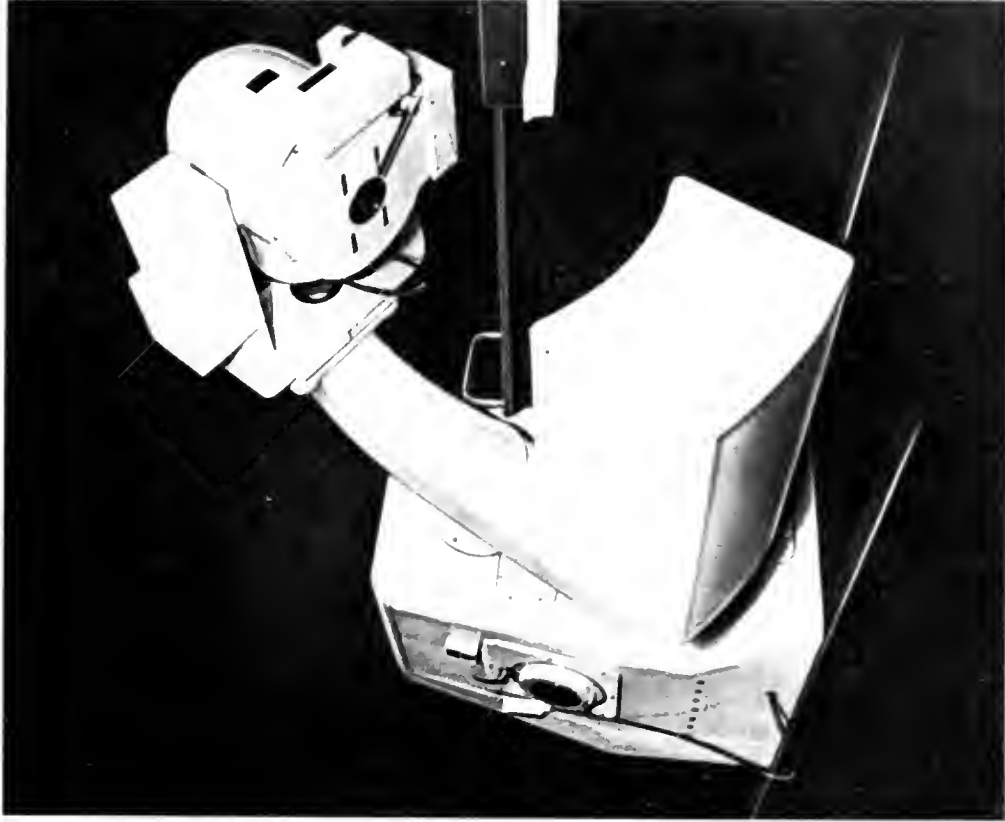

Fig. 4—Another 100-curie machine, somewhat simpler than the one shown in Figs. 1 to 3 but with about the same efficiency.



(a)



(b)

Fig. 5 — Two machines made by the Tokyo Shibaura Co. (a) 200 to 400 curies; (b) 1000 to 2000 curies (can be used for rotation therapy).

City of Hope Teletherapy Unit

CHAPTER 16

Melville L. Jacobs

City of Hope Medical Center
Duarte, California

The machine I shall discuss was designed by a Chinese physicist from the California Institute of Technology who has joined our group.

The unit is a cylinder 8 ft long and 18 in. in diameter. The front, or working end, contains a light localizer, the source, and the exit portal. The head is of cast lead of 4 per cent antimony, through the center of which runs a hollow cylinder 4 in. in diameter. The source, in a uniform source container of tungsten alloy, is wedged between two sections of cast lead. The two lead sections, the source, and the light localizer move horizontally as a unit through a distance of 10 in. from the off position to the on position.

The mid-section houses the pneumatic mechanism that drives the source through its 10 in. of travel. The third, or rear, section consists of a lead cylinder encased in steel, through which a central hollow cylinder, 5 in. in diameter, passes. In this cylinder is a manual connection for pulling the source out of position in case of a power failure.

Figure 1 illustrates the working mechanism. The source moves from its protected position, as seen in the illustration, through 10 in. of horizontal travel to the on position. The light-localizing bulb moves a

similar distance through the horizontal plane. The source is moved by pneumatic pressure, the mechanism for which is housed in the central section.

The unit, as shown in Fig. 2, is mounted on a central pedestal, which is a hydraulic lift mounted on the floor. This unique feature permits considerable flexibility. One of the small cones is shown in place. The cones are made of hand-machined brass, naval brass. We would prefer one of the wedge localizers or variable cones, but we can buy many more cones of the type shown for less than the cost of the variable wedge localizer.

Figure 3 is a diagram of the room that houses the unit. It is built of concrete and has a maze. The wall toward which the beam is usually pointed is concrete 30 in. thick. The outside walls are 12 in. and the wall at the control window is 18 in. of concrete. The viewing window consists of 16 in. of plate glass, and, although it obstructs the light considerably, visibility is still adequate.

The unit has been in use for one year, with nothing having gone wrong with it. It is moderately flexible. Whether it has features superior to the other units that have been demonstrated, I do not know, but we find it easy to use and like it very much.

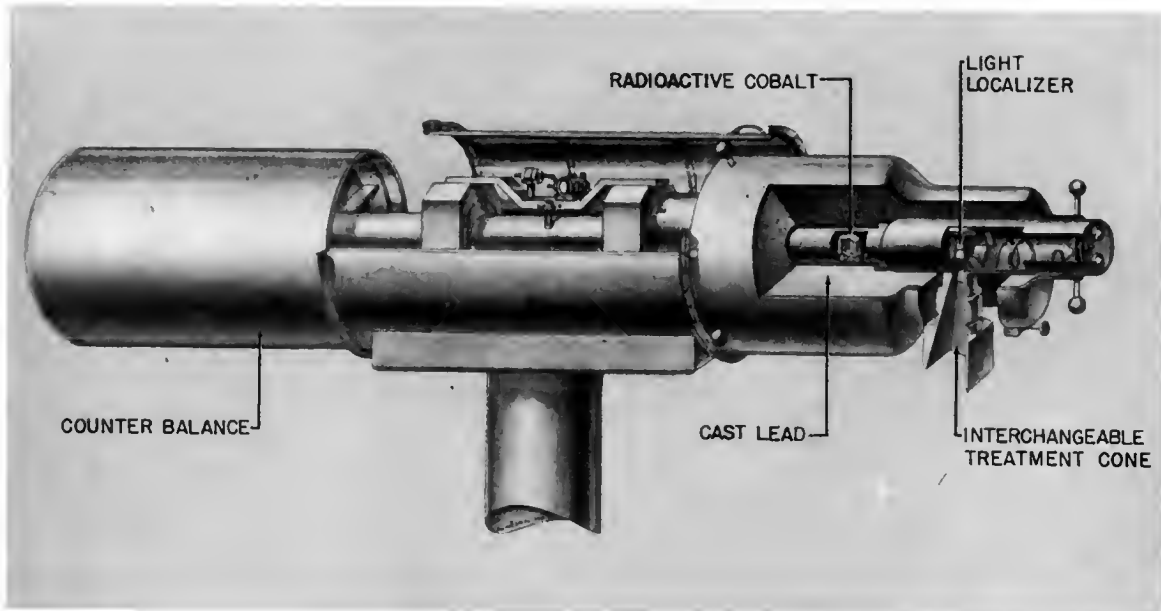

Fig. 1—Cutaway diagram of the working mechanism of the City of Hope teletherapy unit.

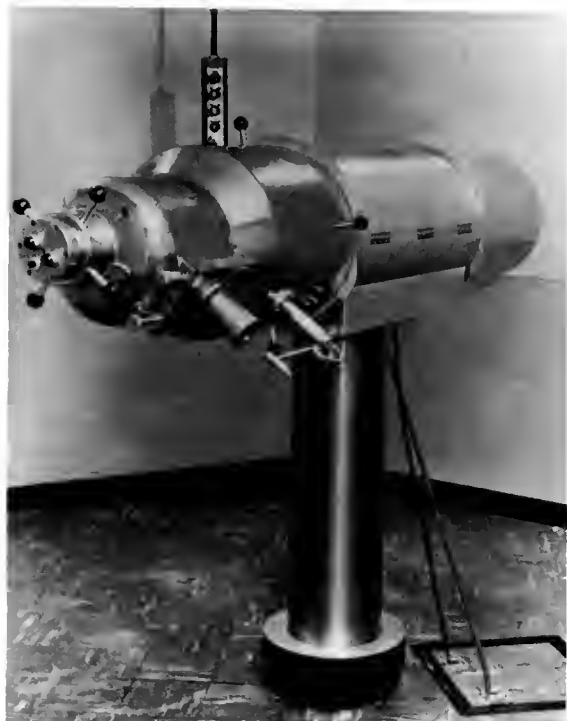

Fig. 2—The City of Hope teletherapy machine mounted on a central pedestal, showing the hydraulic lift mounted in the floor.

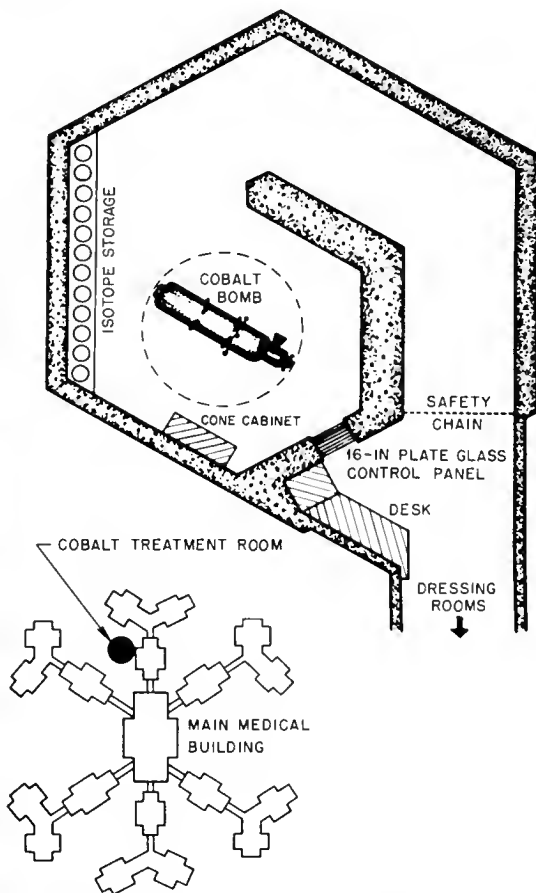

Fig. 3—Diagram of the room that houses the City of Hope teletherapy unit.

Emory University Teletherapy Unit

CHAPTER 17

H. S. Weens

Emory University
Atlanta, Georgia

I am not a representative of a commercial company, and I am certain that you would not wish to purchase the type of unit I shall describe. We became interested in obtaining a cobalt unit late in 1952. We wondered whether it would be simple to develop an inexpensive small cobalt unit containing approximately 200 curies.

In conjunction with our physicist, John Tolan, we proceeded with the development of a unit of this type. The Emory University unit was designed and built by the Research Engineering Station of the Georgia Institute of Technology.

Figure 1 shows the Emory University cobalt therapy unit, which was originally loaded with 295 curies of radioactive cobalt. To keep expenses at a minimum, we used in the construction of this unit a number of items received as gifts. Thus we used an old X-ray tubestand, which proved to be excellent for this particular application.

Figure 2 shows a side view of the unit. A part of the control unit can be seen at the left. This control unit is very small and is mounted under the observation window. The unit has removable cones, each of which weighs about 17 lb.

Figure 3 is a cross section of the unit. It shows a wheel shutter system as used in many other units. This wheel is driven by a pneumatic system. We have heard a great deal about the advantages of other units, but I shall describe some of the disadvantages of our unit. This pneumatic system has not been entirely satisfactory. Although we had no trouble in returning the source to the off position, there was occasional

difficulty in moving the source to the on position, which frequently required adjustment of the valves. Presently this pneumatic system is being replaced by a system driven by an electric motor. This should not prove to be difficult since the entire drive mechanism is outside the unit proper.

A wheel on top of the unit permits mechanical operation of the shutter in case of emergencies. The pneumatic system works against a spring so that, if power fails, the unit will return to the off position.

One of the disadvantages of our unit is that we do not possess a variable diaphragm. Until such a variable diaphragm is designed, we use a somewhat crude variable field-limiting system designed by Dr. Redd of our staff. This system can be attached to our cones (Fig. 4). Figures 5 and 6 show the radiation levels surrounding the unit; they are higher than we desire in the region of the observation unit. The areas of high radiation level, particularly in the region of the dressing room, are well controlled, however. We wish to stress that this is only a temporary location and that this unit will be moved into new facilities with more adequate wall protection (24 in. of concrete), which should amply take care of this particular problem.

In summary, the operation of the unit has been largely satisfactory during two years' operation. Though hand operated, the stand has proved to be satisfactory. At the present time the base of the stand interferes somewhat with the movement of the treatment couch. However, in our new clinical facilities the base of the unit will be recessed into the floor, which should eliminate this problem.



Fig. 1—The Emory University Co⁶⁰ teletherapy unit.

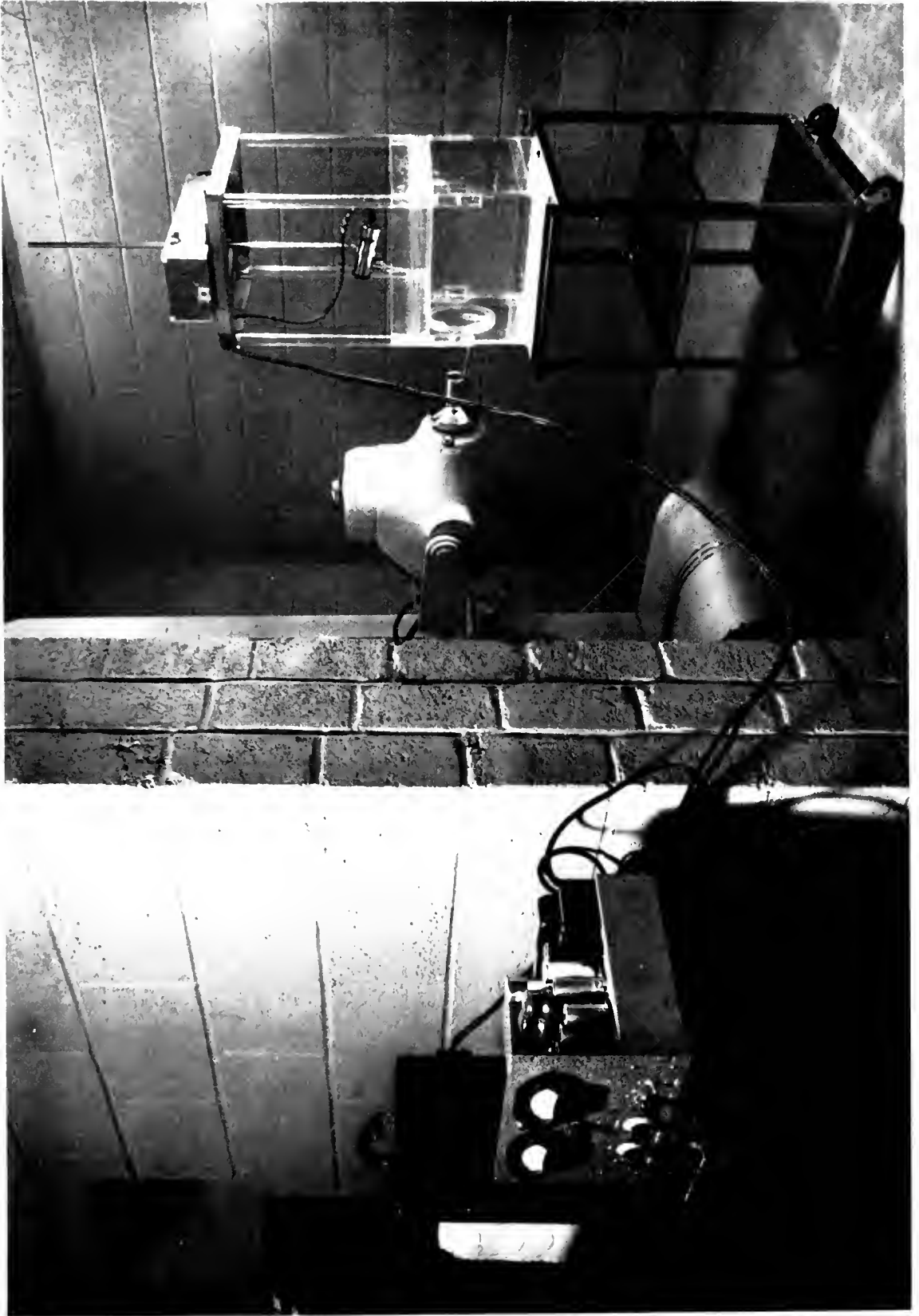

Fig. 2 — Automatic isodose plotter and amplifier with the teletherapy unit.

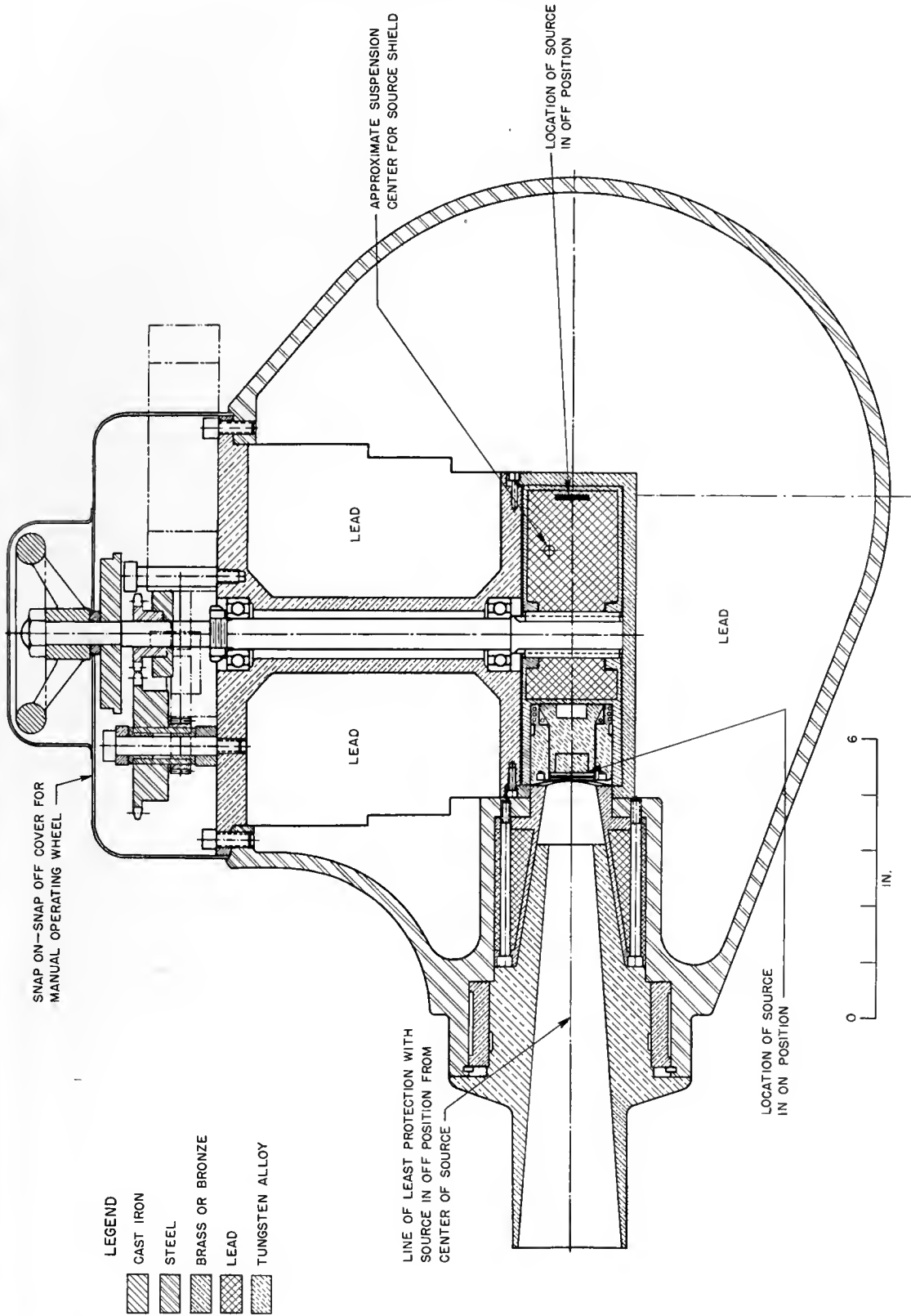

Fig. 3—Cross-sectional diagram of the unit.

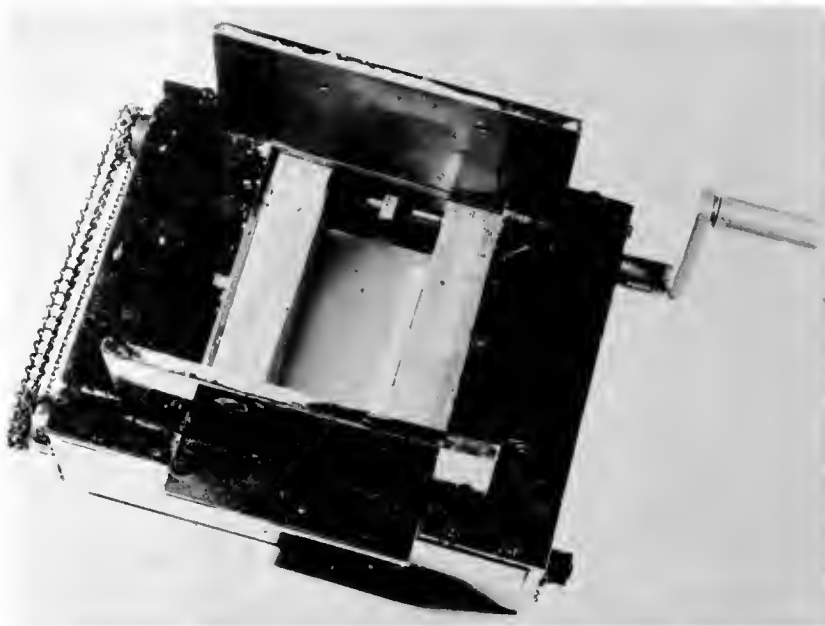

Fig. 4—Variable field-limiting system that can be attached to the cones of the Emory unit.

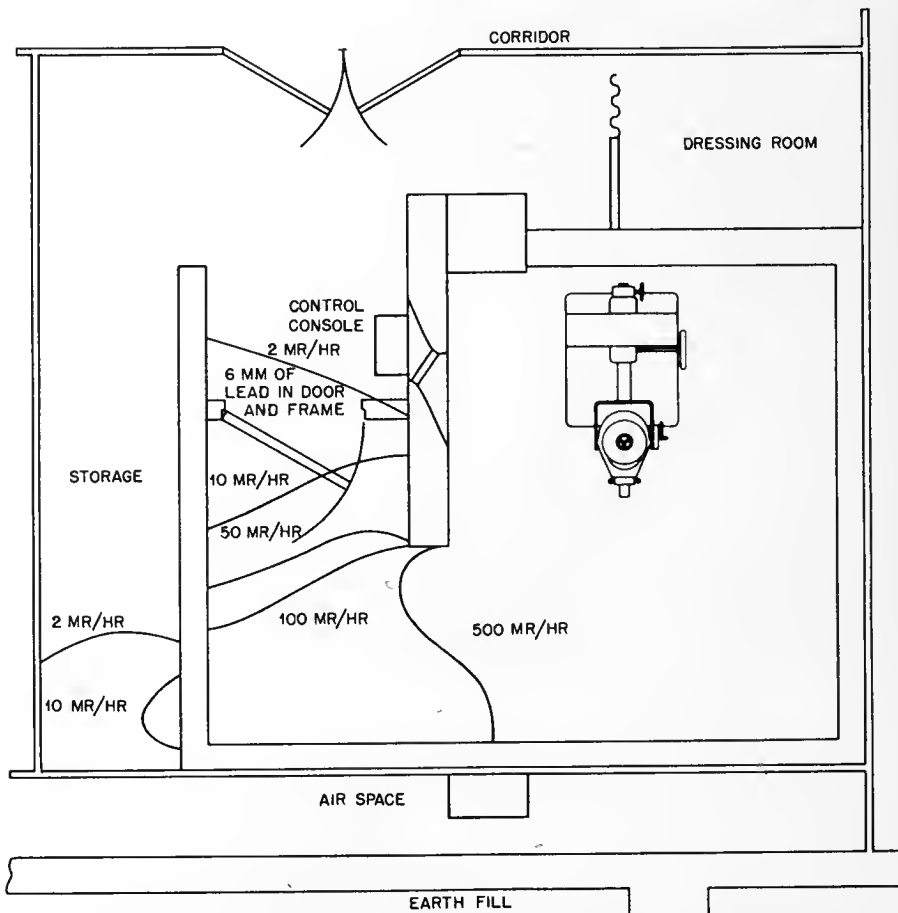

Fig. 5—Radiation levels in a horizontal plane 3 ft from the floor. Beam, horizontal; source, 2 ft 9 in. from floor; rice phantom at 30 cm source-to-skin distance (SSD); door open. (When the door is closed, the 2 and 5 mr/hr lines at the entrance fall within the door.)

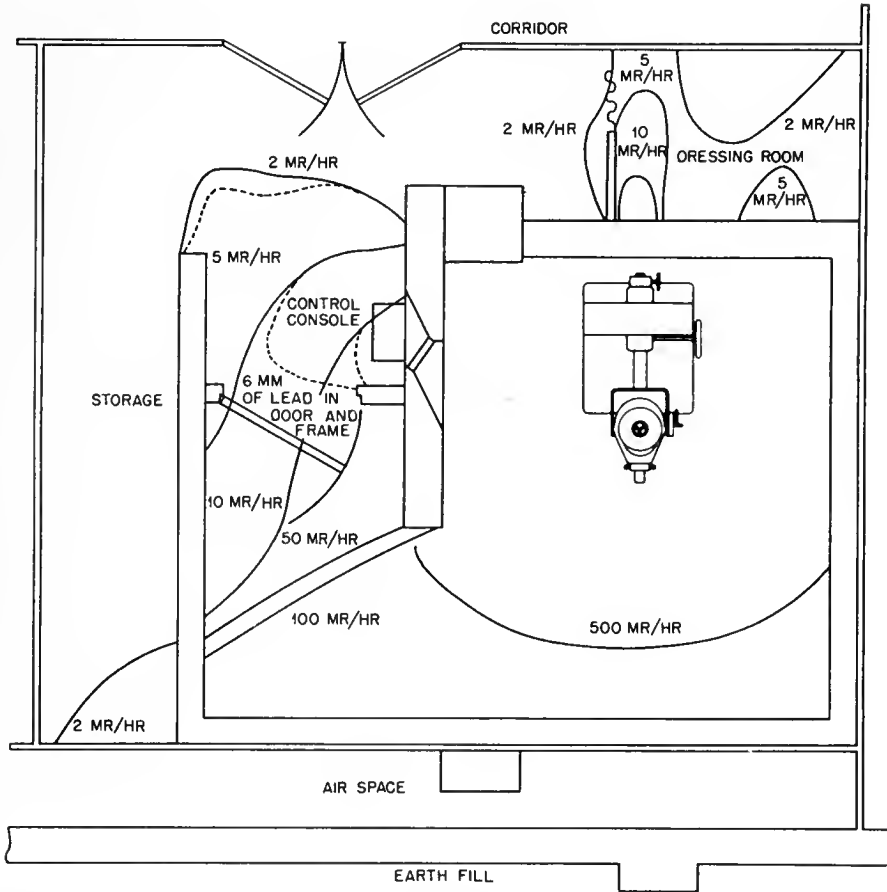

Fig. 6—Radiation levels in a horizontal plane 3 ft from the floor. Beam, vertical down; source, 5 ft 2 in. from floor; rice phantom at 50 cm SSD; door open (—) and door closed (----).

DISCUSSION

CHAPTER 18

R. Quick: For purposes of comparison the commercial units can be divided into three groups. First, there are the Theratron and the Keleket two-headed machines. I had not seen the latter before, and I had planned to say that the Theratron was unique. However, it is not so unique now since there are two of them.

Second, there are the smaller rotational units, the Theratron Junior, the Picker C-1000, and the Keleket-Barnes unit; and, third, the group of stationary non-rotational units, all of which have many similarities. In view of the difficulty of finding any striking differences among these, I shall leave that to the remaining speakers, but I thought it might be useful to list some of the features that should be the main criteria of the designs.

There are, for example, the activity and dimensions of the source. Not much can be said about these factors because they are tied up with the available units. The geometrical size of the source has some effect on penumbra, but I wonder if the penumbra is really quite as important as it is sometimes considered to be. My former colleague, J. L. Haybittle, has suggested that the effect of penumbra on integral dose is not so important as it may have originally seemed to be.

A number of features in the design of the head which are closely interrelated must be considered: the main shielding, the method of exposing the source, and the effect this may have on shielding in the on position. One of the commercial speakers—Mr. Green, I think—brought up this point in the question of the wheel type vs. the more orthodox form of shutter; it is true that with the wheel arrangement there is a danger that the available shielding, if not carefully considered, may be somewhat reduced. Most of the speakers have discussed the methods for operating the closing mechanism in the event of a power failure, but the possibility that the emergency arrangement, the handwheel or whatever is provided, will stick should be recognized. Again, in the Picker unit, is it

correct that the motor always drives against a slipping clutch?

Green: Yes, that is true.

R. Quick: Is that going to involve any possible mechanical problems?

Green: It is an anticurrent type clutch.

R. Quick: Again the design of the exposure mechanism to diminish danger of source sticking in the on position is obviously very important.

Another point was the provision of precautions—and I assume that they are provided for most of the units—to prevent danger to the patient from these massive amounts of lead and tungsten rotating around him if he should suddenly sit up or move about. I know that usually the speed is comparatively low so that he would probably have plenty of time to duck as the head moved in its arc, but I do not think any great stress was placed on provisions of this kind.

The Atomic Energy of Canada, Limited, representative described their method of loading and changing sources; I should be interested to know the methods used by other manufacturers.

The diaphragm collimation system is obviously quite important. The advantage of an adjustable collimator is that it obviates the necessity of moving, heavy, large, lead diaphragms, but it also introduces a fairly complicated mechanical system. Again there is the question of the amount of space available, especially for rotation, between the collimating system or the diaphragm and the patient and whether this distance is cut to rather a small limit or not. It is essential that separate control units be provided inside the treatment room for positioning the rotating head or the unit.

Another factor to be considered, especially for the more complicated designs, is that the market for therapy equipment will consist of a small number of large centers and a larger number of smaller places; the larger centers will have the money to purchase

the large, complicated equipment and presumably will also have the staff necessary to handle and use it properly. The smaller hospitals are unlikely to have the same amount of money and, more important, the available staff to make adequate use of the equipment. From the point of view of local prestige, it should be remembered that elaborate equipment is always much more impressive than extra staff, and it is always possible to buy a large machine for which donations are easily obtainable; but donations for extra physicists are much more difficult to obtain.

Finally, in practice the deciding factor in the choice of a particular unit will often be the same as that for orthodox X-ray equipment, which is the reputation of the various firms in the area for service.

One very important point brought out by Mr. Stober was the training of technicians and staff for emergency, especially the third step, if everything else fails, of removing the patient on the couch. Now what happens with the units that have a fixed couch tied to the machine? You presumably have a loose top and pull the patient in the hope that he hits the floor outside the room.

Braestrup: One of the things we must realize is that there is not such a thing as the ideal cobalt machine. Mr. Green pointed out that any design is a compromise, and I agree one hundred per cent. However, I think there is a limit to the compromise, and it is dangerous to consult too many radiologists and physicists about the design of equipment. The result is likely to be a machine that can do many things, but none of them well.

I believe that the main advantage of the rotating equipment is not so much that you can accomplish rotation therapy; after all, there is less need for rotation with cobalt than there is with conventional X-ray therapy where the skin is the limiting factor. The principal gain is that, once you have positioned the patient so that the center of the tumor is at the axis of rotation, you can easily shift from one field position to another with the assurance that the central beam still passes through the center of the tumor.

I should like to say a few words about the shielding of source housings. Originally it was recommended that the shielding in the off position be 6.25 mr/hr at the surface. This value is simply 300 divided by 48, and it bears no relation to teletherapy. Subcommittee No. 9, in the preparation of National Bureau of Standards Handbook 54, realized that it would be wrong to stick to that figure because, first, you cannot measure to that accuracy and, second, it had no real meaning. We decided on 2 mr/hr at a distance of 1 meter, with a maximum for pinholes etc. of 10 mr/hr; this was also adopted recently in Geneva by the International Commission on Radiological Protection.

In addition, there is very likely to be another limitation, i.e., the radiation level at the surface, so that when you have a very small source housing, there still will be adequate protection. Perhaps of almost equal importance is the shielding in the on position. If shielding is inadequate, both the integral dose to the

patient and the room-protection requirements increase materially. Originally it was specified that the leakage radiation not exceed 1 per cent of the useful beam, but it was recommended that it be reduced to 0.1 per cent. I should like to ask the manufacturers whether they would raise any serious objection to reducing this value still further. This would decrease the protection required in the walls and floors of the room and would provide a higher degree of safety to the patient.

In the table shown by Dr. Roberts, it was not quite clear to me whether it was the leakage radiation of the collimating system.

Mr. Stober mentioned the emergency procedures, and I agree with the items he mentioned. I suggest, however, that the first thing to do is to remove the patient from the room rather than to try to change the position of the beam control by hand; if the beam control does not operate properly, it is probably damaged, and it is better to remove the patient from the room and have the manufacturer repair the beam control. Dr. Quick asked how the couch could be removed when it is an integral part of the equipment. In most designs the couch can be released and slid out. The technician is not likely to get an exposure of more than 50 mr during this procedure. I think the advantages and disadvantages of the different types of beam-control systems have already been pointed out; it is obvious that, if a short treatment distance is desired, the wheel type is the better one. For a higher degree of shielding the shutter type is preferable.

Eberhard: In any discussion such as this, one has to make assumptions. The first assumption, implicit in the very existence of this meeting, is that teletherapy, particularly cobalt, is something desirable. There are people who will argue about this. Perhaps before this meeting is over, we shall become involved in discussions of other isotopes of different energy levels, and by the time we finish our whole idea of machine design may undergo some alterations.

It is impossible to design one machine that will treat every kind of disease for which we attempt to use radiant energy. All the desired protection, the maneuverability, and the flexibility in source-to-skin distance cannot be obtained if the size and the price are to remain reasonable.

The first consideration is safety. These machines must be no more lethal than necessary. The manufacturers are cognizant that shortly there will be many of these machines in the hands of people who are not highly skilled or experienced. It is therefore desirable to lean further backwards than we have so far in making sure that personnel working around these machines cannot be exposed to excessive amounts of irradiation.

I want a machine that requires a minimum of physical labor in handling and one that requires a minimum of "doughnut-twisting" on the part of the patient. The only patient who will really lie still is the one who is lying flat on his back, and I am dubious about some of the designs that are relatively rigid and in which

the patient must be propped up into a queer position.

Field definition also involves work; I have visited some of my teletherapist friends and lifted some of the clip-on removable cones. If someone could devise a good collimator which does not take up too much space, which is thoroughly reliable, and which does not have too much leakage around it, it would be preferable.

Also there is the problem of fixing distance. You can bring a cone down on the patient and know that the machine is at the proper distance. When you are using a collimator and a light localizer, you hope that everything is the way it ought to be, but you cannot be certain. I do not know how far one should go in guarding against these dangers. I prefer a localizer simply because I am too lazy to throw the cones around.

Another interesting thing to me is the discussion concerning penumbra; perhaps by the end of the seminar this problem will be somewhat clarified. I do not see how the manufacturers can possibly make any advances in design when no one will agree about the importance of penumbra. It seems to me that the less penumbra we have, the more efficient is the irradiation.

Brucer: To answer some of Mr. Clark's questions, we should have called upon Dr. Ellis first. He was the first person I heard of who began to think of machines with multiple or extended sources. We should also call upon Dr. Hummon, who has about as extended a source as is possible.

Ellis: I should not call it an extended source. I should call it an extension of the pinpoint source as far as possible. When the specific activity of Harwell cobalt was rather low, to get a high output with not too large a source and to get as small a penumbra as possible, I suggested that we use a ring of sources with the patient in the middle (Proceedings of the Isotope Techniques Conference, Her Majesty's Stationery Office, Oxford, July 1951). When the specific activity of Harwell cobalt improved, there seemed to be no point in pursuing the idea.

However, with cesium, because only a relatively small output for a 1000-curie source (about 3 cm in diameter) can be obtained, it seemed to me that using multiple sources might well be a good arrangement for improving the output, especially since the possibility is that, with further developments, cesium production will be very large.

I have a proposal for a cesium unit with about 20 sources distributed in a ring at a focal-to-skin distance of about 70 cm, which will have an output of about 100 r/min. The difficulty with this multiple-source unit is the diaphragm system, but we have a possible solution.

This method seems to be a form of stationary-rotation therapy, but it is not quite the same because with rotation therapy the part of the patient nearest the source moves most quickly across the beam; whereas, with a fixed patient and a fixed ring of sources, the part of the patient nearest the source stays in the beam just as long as the other parts and so tends to get a larger dose.

Section D

Installation Problems

Galen M. Tice
(presiding)

100

Problems of Supervoltage Installation and Protection

CHAPTER 19

Carl B. Braestrup

Francis Delafield Hospital
New York, New York

Within the next few years a supervoltage installation may be expected to be an essential facility in most radiotherapy departments. It is important, therefore, that in the design of new hospitals consideration be given to these facilities in the early stage of the planning activities.

The increased availability of Co^{60} sources with high specific activities and the wider choice of equipment have stimulated the interest in teletherapy. I shall limit my remarks to gamma-beam installations. Their problems are almost identical with those of supervoltage X-ray installations of the same energy. Beyond 2 or 3 Mev, there is such a big difference among various types of equipment that it is difficult to offer standard rules.

The problems involved in planning teletherapy facilities differ in important aspects from those of 250-kv roentgen therapy. The protection requirements are much greater and vary widely with the type of gamma-beam equipment. The factors affecting the shielding are summarized as follows:

1. Equipment
 - a. Roentgens per hour at 1 meter (or curies)
 - b. Polar plot of leakage radiation of source housing (and built-in primary shield, if any)
 - c. Work load in roentgens per week at 1 meter
 - d. Use factor for walls, floor, and ceiling
2. Maximum radiation levels
 - a. Maximum permissible average weekly exposure for controlled areas
 - b. Maximum permissible milliroentgens in 1 hr (Atomic Energy Commission and state regulations)
 - c. Nonmedical exposure limitations due to nearby storage and processing, isotope counting, etc.
3. Site characteristics
 - a. Materials and thicknesses of floor, ceiling, and walls
 - b. Distance to nearby buildings and other occupied areas

- c. Degree of occupancy of surrounding regions
- d. Other nearby sources of radiation

Primary Protective Barriers

Minimal room shielding is needed for low-curium apparatus with built-in primary shield, but the structural protection requirements are maximum for multi-curium equipment with no primary shield and unrestricted beam orientation. The weight of cobalt teletherapy equipment itself varies greatly, from less than 2 tons to more than 8 tons. The weight of the average 250-kv machine is 3 tons. Weight considerations alone may determine, therefore, the selection of the equipment and its location. The shielding requirements of the extremes differ also by a large factor. This is illustrated in Fig. 1.

An installation with the concrete floor exposed to the useful beam is shown on the left. The full thickness of the floor indicates the shielding required for 2000-curium equipment. It can be seen that a change in curies affects the barrier thickness relatively little. A decrease from 2000 to 500 curies reduces the barrier thickness only about 10 per cent. An installation using equipment with a built-in radiation shield is shown on the right. This usually is designed to attenuate the incident radiation to less than 0.1 per cent; it therefore cuts down the shielding requirements of the floor significantly, i.e., by at least 10 half-value layers (HVL), or by about 27 in. of concrete. Since the required floor thickness is less, a reduction in the curium causes a relatively greater decrease in thickness, about 22 per cent.

In both rooms shielding has been provided to reduce the radiation to 0.25 mr/hr at a height of 6 ft above the floor. The value of 0.25 mr/hr has been selected because an irradiation of 40 hr/week will result in an exposure of 10 mr/week, or the maximum permissible average value outside controlled areas. This is one-tenth of the average maximum permissible dose for

controlled areas. Actually, the exposure of persons on the floor below will be considerably less since, in passing through the patient, the radiation has been reduced to about one-third of its unattenuated value

to limit the lead shielding to this area and to taper it off as the beam passes obliquely through the barrier and the distance to occupied regions increases. This has been discussed in an earlier report.¹

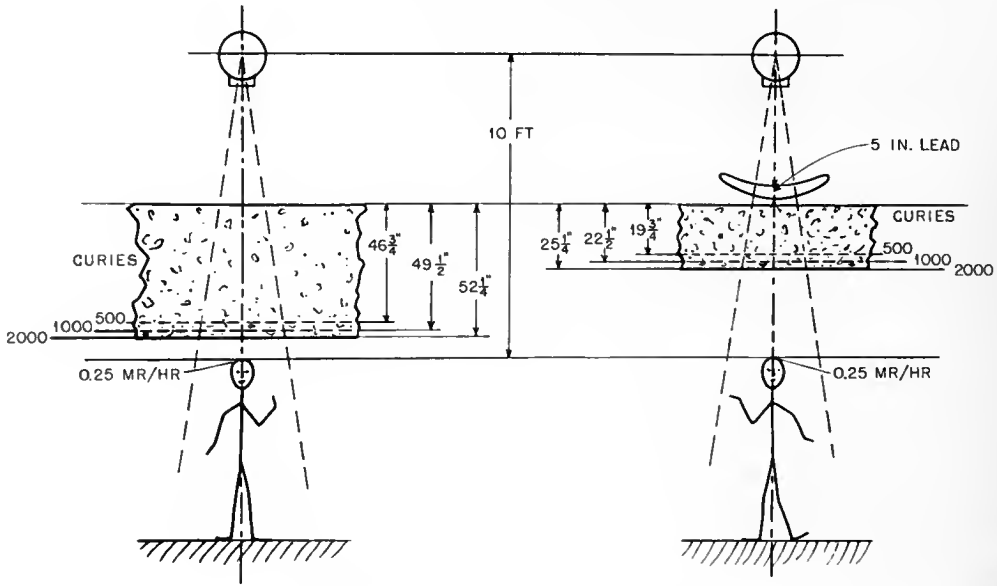

Fig. 1—Primary shielding requirements.

and the total weekly irradiation time is usually less than 40 hr. Furthermore, the critical organs, the gonads, are at a greater distance from the source. There is therefore a high factor of safety as far as health aspects are concerned. It should be realized that sometimes the radiation level must be reduced still further to prevent damage to films or interference with counting equipment.

Figure 1 also illustrates the shielding economy gained by installing teletherapy equipment on the bottom floor of a building, particularly if the equipment has no built-in primary shield. This does not mean, however, that such a location is necessarily the most advantageous. Factors other than shielding require consideration too. Gamma-beam installations preferably should be close to other radiotherapy facilities in order to avoid a divided department since this may require more personnel and less effective supervision. An upper-floor location of cobalt teletherapy installations, therefore, may sometimes be preferred if economically and technically feasible. For such locations equipment with built-in shielding offers particular advantages. Usually it is not practical to provide concrete floors some 4 ft thick since it might interfere with the head room below. The thickness of the floor can be reduced by replacing part of the concrete with lead; this is obviously an expensive construction and is justified only where structural conditions prevent the use of concrete barriers only. The ratio of concrete to lead thickness is about 5.5 for the primary radiation. In most installations only part of the floor is exposed to the useful beam. It is therefore possible

The wall shielding requirements for horizontal-beam orientation toward an adjacent room are similar to those for the floor except that the use factor is generally lower. Unless otherwise indicated, it is usually assumed that the beam is pointed toward the wall only one-fourth of the total irradiation time, i.e., the use factor is 1/4. On upper floors the need for heavy primary barriers in the walls can be eliminated if the beam is directed only toward the outside walls and if there are no nearby buildings or other occupied areas. The distances required to reduce the primary beam to the permissible level are often much greater than realized, and the equipment should be so located that the useful beam cannot be directed toward outside windows if there is any nearby occupancy.

Secondary Protection Barrier

So far we have considered only primary barriers, i.e., those exposed to the useful beam. By limiting the beam orientation, it is possible to reduce the areas that require primary shielding. For equipment with a built-in primary shield, the therapy room needs only secondary barriers, i.e., those exposed to leakage and scattered radiation only.

The leakage radiation includes the rays passing through the source housing and through the primary shield. Leakage radiation varies with the different makes of equipment, but generally it is less than 0.1 per cent of the primary beam. For equipment with shutters for the beam control, the maximum leakage

radiation of the source housing is usually much lower, being only about one-millionth part of the primary beam.

values of Dixon, Garrett, and Morrison.³ Figure 3 shows the attenuation in lead; as might be expected, the angle of scatter is more critical. This can be

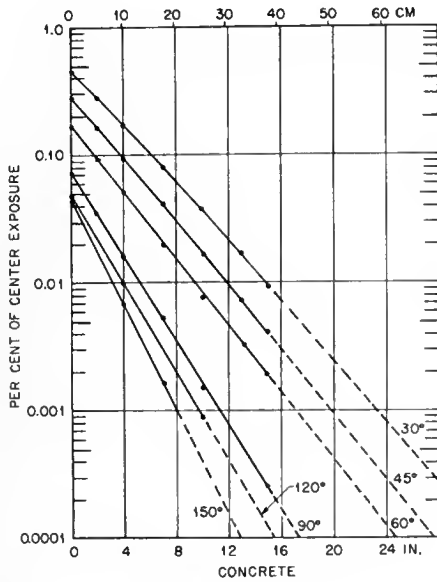

Fig. 2—Attenuation of Co^{60} scattered radiation from cylindrical masonite phantom in concrete.

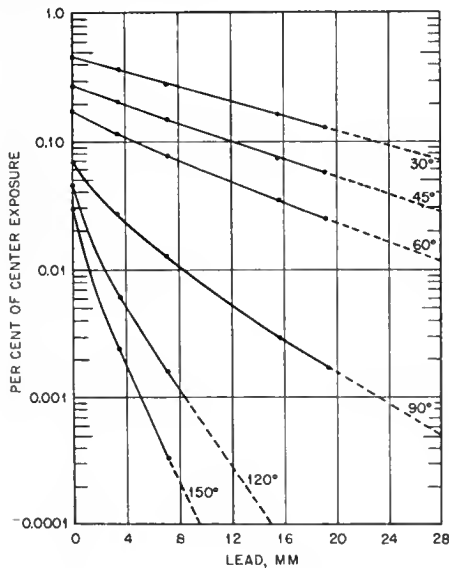

Fig. 3—Attenuation of Co^{60} scattered radiation from cylindrical masonite phantom in lead.

Both the intensity and the energy of the scattered radiation vary widely with the angle of the scatter. In Fig. 2, the attenuation in concrete of the scattered radiation from the patient is shown in percentage of the axis air dose. Our measurements, described in a separate publication,² are in close agreement with the

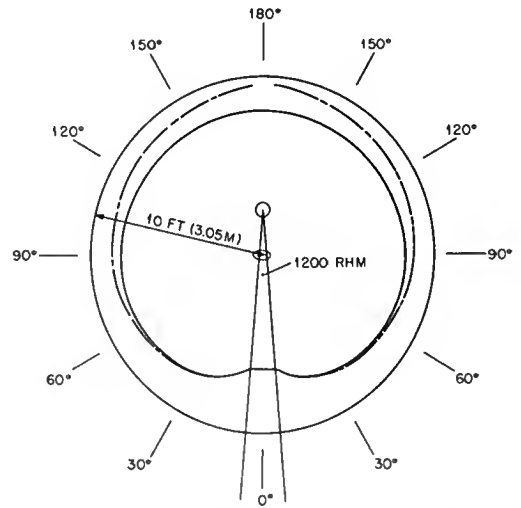

Fig. 4—Schematic diagram showing concrete shielding required to attenuate primary, scattered, and leakage radiation to 1 mr/hr at 10 ft. ———, total concrete-barrier thickness if leakage radiation from source housing is 0.1 per cent of the primary beam. - - - - -, total concrete-barrier thickness if leakage radiation from source housing is 2 mr/hr at 1 meter.

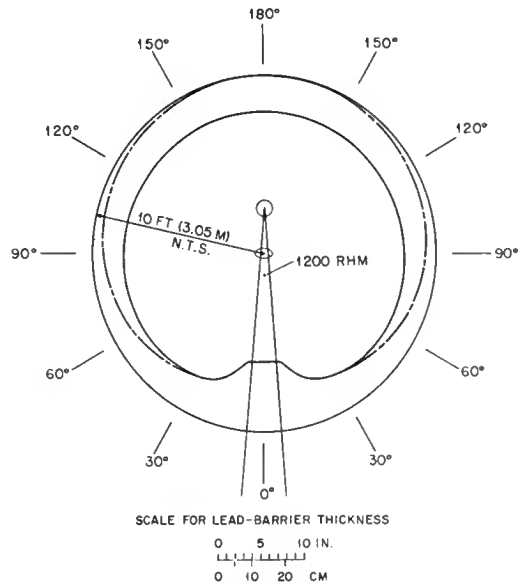

Fig. 5—Schematic diagram showing lead shielding required to attenuate primary, scattered, and leakage radiation to 1 mr/hr at 10 ft. ———, total lead-barrier thickness if leakage radiation from source housing is 0.1 per cent of the primary beam. - - - - -, total lead-barrier thickness if leakage radiation from source housing is 2 mr/hr at 1 meter.

illustrated by considering the barrier thickness required to attenuate the primary and scattered radia-

tion from a kilocurie source to 1 mr/hr at 10 ft. Figure 4 shows graphically the variation in the thickness with angles for concrete. It is obvious that significant shielding economy can be gained by reducing the areas requiring primary protection. This is particularly true where the leakage radiation of the source housing is low. The broken line indicates the barrier thickness for this condition. It is even more evident where the barrier is of lead, as shown in Fig. 5.

Since the leakage radiation is an important factor, it is necessary, therefore, in planning room shielding to consider the attenuation of the source housing and of the primary shield if there is one.

less is the contribution of scattered radiation. The access of equipment, stretchers, and beds, however, is the primary consideration. The thickness of the maze barriers and of the door shielding must be determined by considering both the leakage and the scattered radiation.

The patient should be under constant observation during irradiation; this is particularly urgent where rotating equipment is used since there is a possibility of collision. Since the observation window should provide the same degree of attenuation as that required of the wall in which it is mounted, it is preferable that the window be located so that it is exposed only to

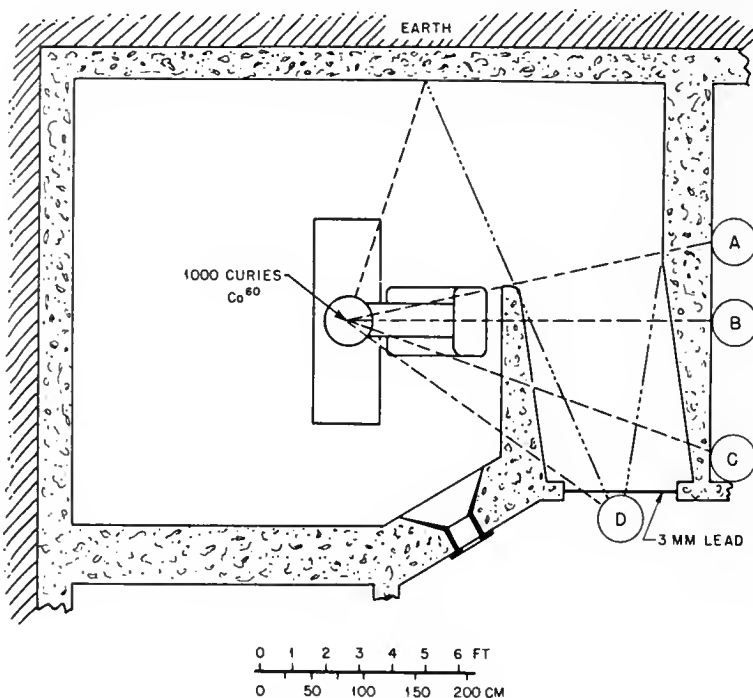

Fig. 6 — Maze design. - - - - -, leakage radiation and scatter from the patient. ·····, radiation scattered from walls.

Doors, Mazes, and Observation Windows

The door to the treatment room should be so located that it is exposed to scattered and leakage radiation only. Otherwise the lead shielding of the door would have to be several inches thick, making it so heavy that it would have to be motorized; the cost of such a door is approximately \$10,000. It is possible to reduce the lead lining to a few millimeters by providing a maze.

A typical maze design is shown in Fig. 6. It can be seen that the door is exposed only to radiation that has been attenuated by the concrete barrier and rays scattered from the walls, floor, and ceiling. It is obvious that the longer and narrower the maze the

leakage radiation and rays scattered at least 90 deg. A corner location has the advantage of providing a more extended view of the treatment room.

Various transparent materials are used for the viewing windows. At present, high density (3.2 to 6.6 g/cm³) lead or tungsten glass is preferred because it affords excellent visibility, requires no maintenance, and is available in adequate thicknesses, eliminating lamination. The lead glass must be mounted in a frame so constructed that it affords the same degree of protection as the window. A closed-circuit television system can be used instead of the window. With television there is the advantage that the control can be located at any convenient place. The cost of the television system is competitive with that of a thick observation window. The main objection is the possibility of electrical breakdowns; therefore provision

should be made for emergency observation. This can be accomplished by indirect viewing through a window in the door and a suitably placed mirror.

Electrical Wiring

In addition to the wiring required by the cobalt equipment, it is desirable that the following items be considered:

1. Two-way communication system between operator and patient.
2. Conduit for ionization-chamber cable to permit measurements of the transmission exposure, etc.
3. Ceiling- and wall-mounted light localizers indicating axis for moving-beam therapy equipment. Lighting of control room should be so arranged that there is minimum reflection at the observation window.
4. All electrical junction boxes should be surface mounted unless shielded by lead at least equal to $\frac{1}{12}$ the thickness of the concrete that the box replaces; they should be so located that they are not exposed to the useful beam.
5. All air-conditioning ducts etc. should pass above the door to the maze so that the maze wall prevents scattering into occupied areas.

Conclusions

It should be emphasized that gamma-beam therapy is still in the developmental stage. Cobalt sources with much higher curiage can be expected to be available in the future. Furthermore, there has been a steady trend toward reducing the maximum permissible dose. Both factors tend to increase the radiation protection requirements. This deserves particular consideration in the planning of installations in new buildings where an increase of a few inches in the thickness of the concrete barriers adds insignificantly to the cost. If possible, provisions should be made also for the conversion of other areas into teletherapy rooms.

References

1. C. B. Braestrup and R. T. Mooney, Cobalt 60 Protection Design, *Radiology*, 65: 884-891 (December 1955).
2. C. B. Braestrup and R. T. Mooney, Attenuation of Scattered Cobalt 60 Radiation in Lead and Building Materials, to be published.
3. W. R. Dixon, C. Garrett, and A. Morrison, Room Protection Measurements for Cobalt 60 Teletherapy Units, *Nucleonics*, 10(3): 42-45 (March 1952).

An Exhibition of the Installation of Co^{60} Teletherapy Machines

CHAPTER 20

Marshall Brucer

Medical Division
Oak Ridge Institute of Nuclear Studies
Oak Ridge, Tennessee

I shall emphasize primarily cost figures rather than protection designs. The physicians who started Co^{60} teletherapy early in the 1950's were taking a big step into the unknown. They did not have the advantages of experience that we now have.

One of the first designs was the installation at Cedars of Lebanon Hospital, Los Angeles, Calif. (Fig. 1). They bought 1400 curies of cobalt at a cost of about \$8800. They paid only \$10,000 for the machine, but this was a highly unusual situation that will not occur again. The manufacturer, in the absence of accounting data, picked a figure out of the sky and later discovered that he had made a gift of the machine to the Cedars of Lebanon Hospital. The cost of the installation was \$42,000, and therefore the cost of the total setup was about \$61,000. This figure must be looked at in the light of what the Cedars of Lebanon Hospital was trying to accomplish. There were two serious problems in the installation. The Co^{60} machine was placed close to a lot of other radioisotope equipment. Protection was a much more complicated problem than the protection of human beings. Scintillation crystals had to be protected. Also, the Cedars of Lebanon Hospital, being in Hollywood, had to have platinum doorknob handles and diamond-encrusted keys for all locks.

There was insufficient room to construct a maze entrance to the teletherapy room. Dr. Jaffe spent hours trying to squeeze a maze into the space that was available but could not do it. Therefore it was necessary to install a very expensive sliding door. This installation, by force of circumstance, became a very expensive one.

Dr. Jaffe's unit was not a routine installation. It was set up as an experimental teletherapy device. Because Dr. Jaffe intended to do experimental work, he hired a physicist. This automatically means that he subjected his hospital to a few hundred thousand dollars' worth of extra equipment that had to be designed and installed. Every three days the physicist had another idea that cost another thousand dollars.

The physicist was probably the most expensive part of the teletherapy machine.

Another early installation was Dr. Simon's unit (Figs. 2 and 3), which was the first teletherapy machine to be placed in a private office. Dr. Simon installed 306 curies at a cost of \$1800, and the machine cost approximately \$20,000. The initial installation cost was about \$10,000, and therefore for the first private-office machine the total cost was about \$32,000. Again, this was not a routine installation in any sense. Dr. Simon put his machine into the smallest closet in New York City. Also it was a closet that was backed up by an apartment house full of little babies. Immediately above the closet, little babies were constantly being born. This is a very unusual place to put a high-energy therapy machine. However, Dr. Simon proved something with his installation. If a cobalt machine could be put in his closet, one can be put anywhere with safety. But Dr. Simon paid for it.

The Emory unit (Fig. 4) in Atlanta, Ga., is another unusual installation. Dr. Weens bought 294 curies of Co^{60} at a cost of \$2800. The machine cost \$10,000, but this again was an unusual purchase. The machine was made at Georgia Institute of Technology. If the machine had been made and purchased privately from a manufacturer who had more respect for the profit motive, it would have cost much more than \$10,000. Dr. Weens's installation cost was \$2000. This installation was also in an unusual location, being in a basement where much of the shielding necessary for a cobalt machine was already in place.

Another installation (Fig. 5) of interest is the 599-curie source at Bellevue Hospital, New York City. The Co^{60} source cost \$4600, the machine cost approximately \$20,000, and the installation was very inexpensive. Dr. Rubinfeld placed his machine in a room already protected for a radium teletherapy device. The Bellevue installation cannot be considered typical.

If we review all the installations (others are shown in Figs. 6 to 13), we shall become very tired and shall still have only one conclusion. The only typical thing

INSTALLATION OF Co^{60} TELETHERAPY MACHINES

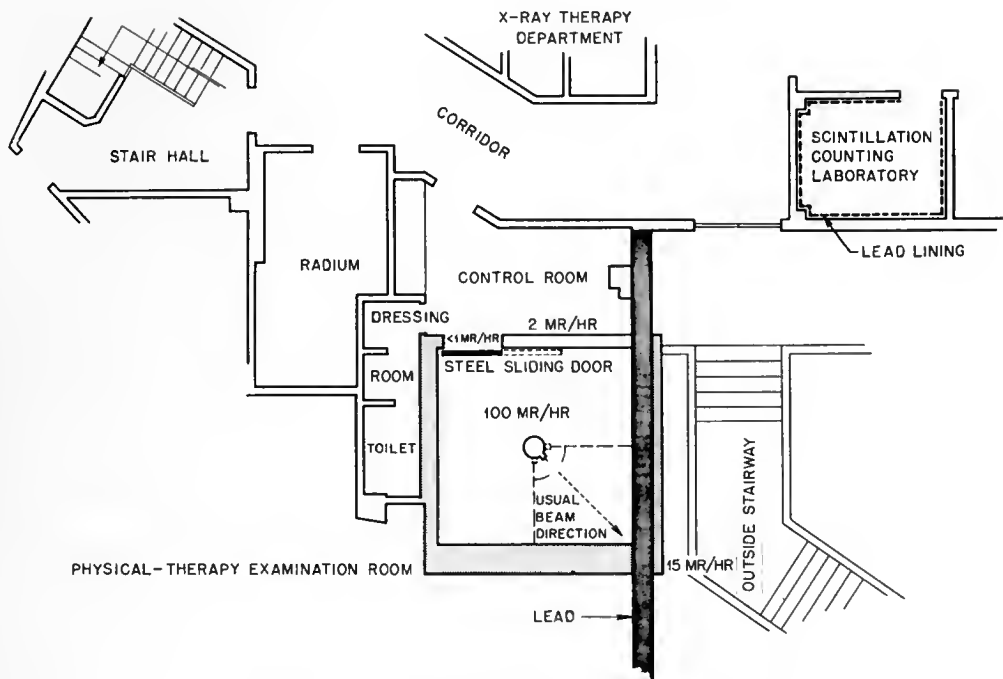

Fig. 1—Cedars of Lebanon Hospital Co^{60} teletherapy laboratory.

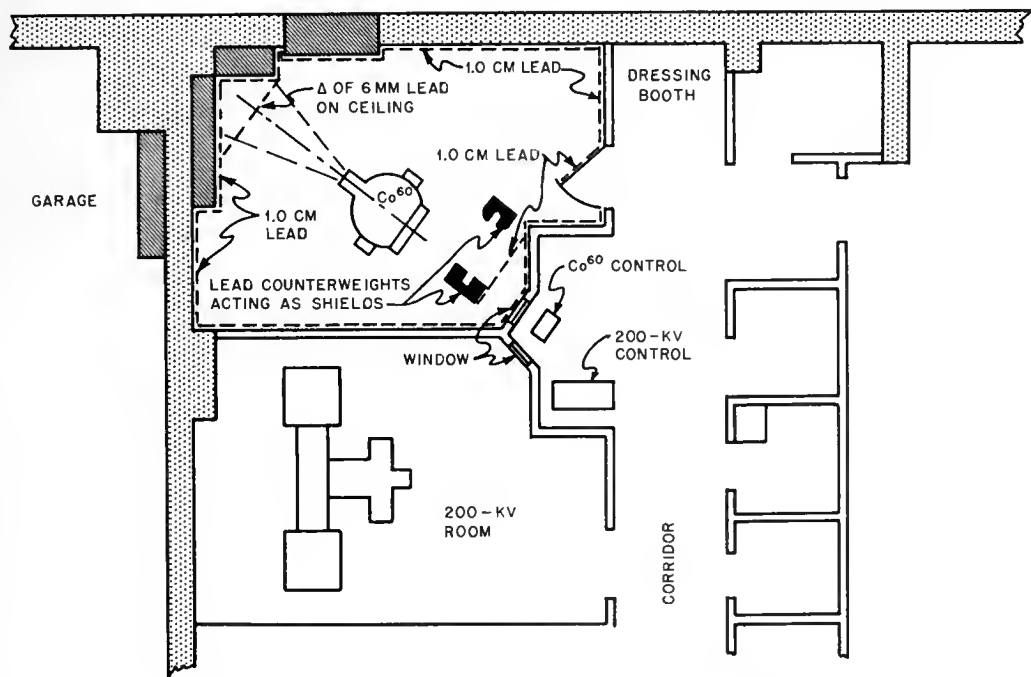

Fig. 2—Plan view of the Silverstone-Simon private-office-unit Co^{60} teletherapy laboratory.

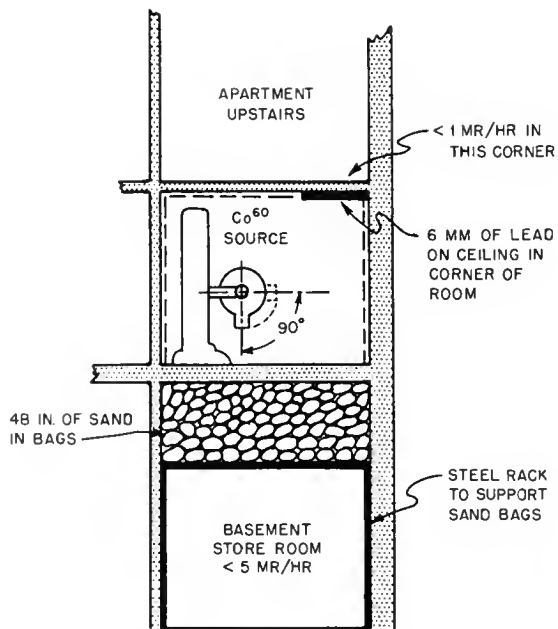

Fig. 3—Elevation plan of the Silverstone-Simon private-office-unit Co^{60} teletherapy laboratory.

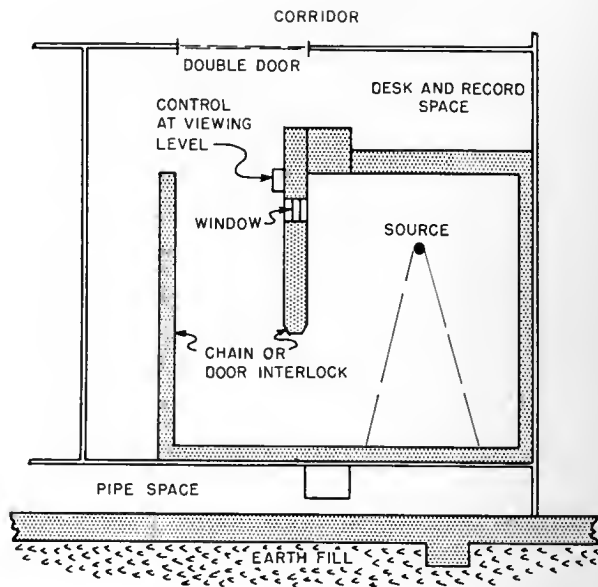

Fig. 4—Emory University Co^{60} teletherapy laboratory.

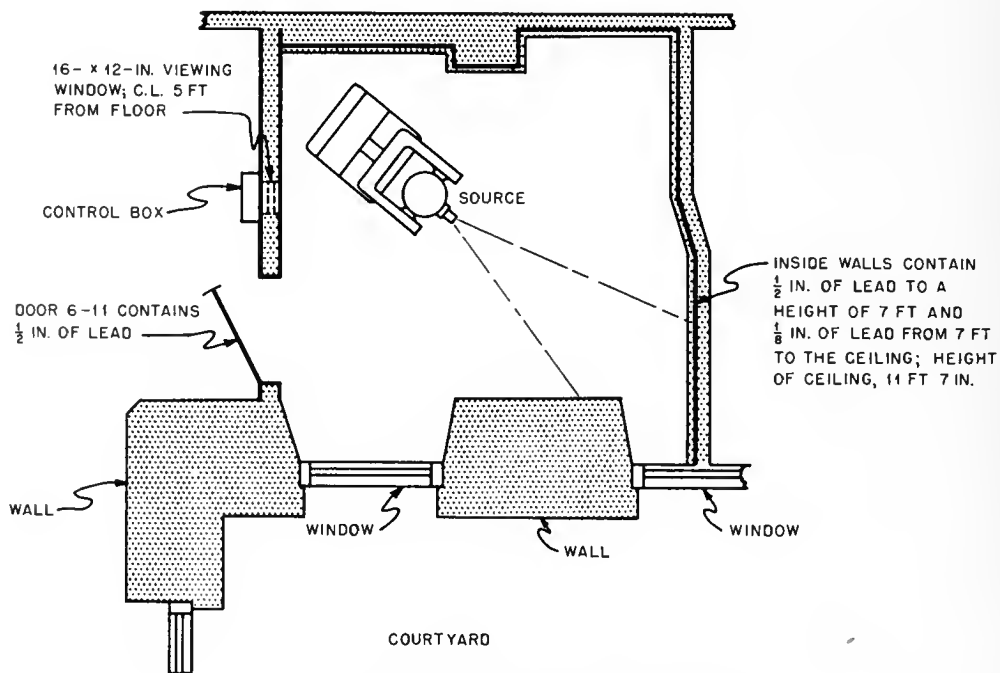

Fig. 5—Bellevue Hospital Co^{60} teletherapy laboratory.

INSTALLATION OF Co^{60} TELETHERAPY MACHINES

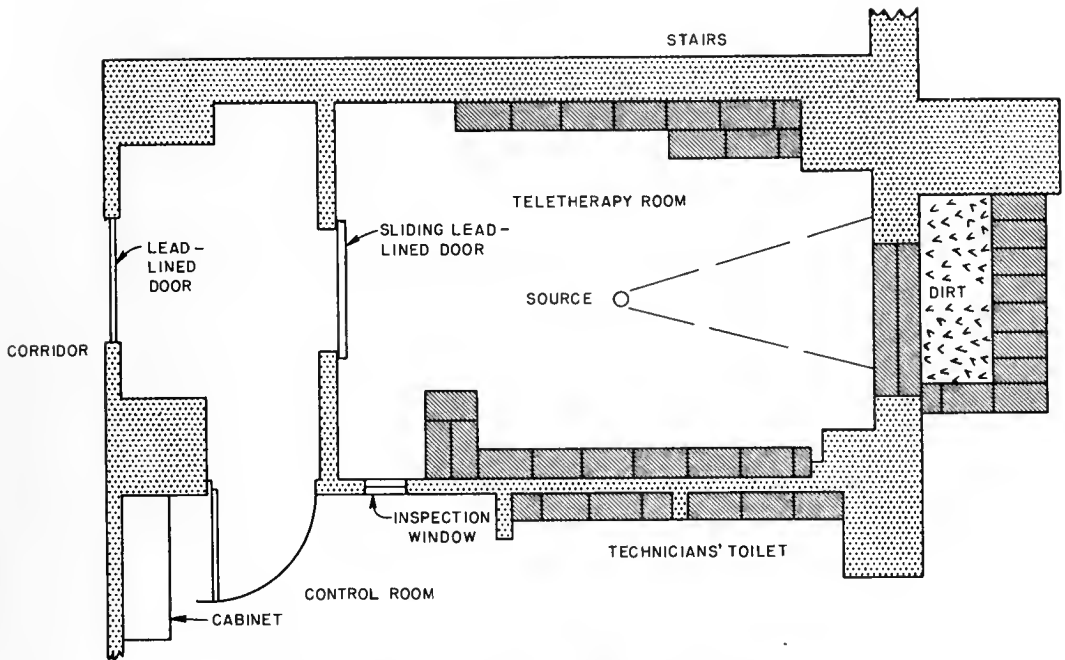

Fig. 6 — University of Arkansas Co^{60} teletherapy laboratory.

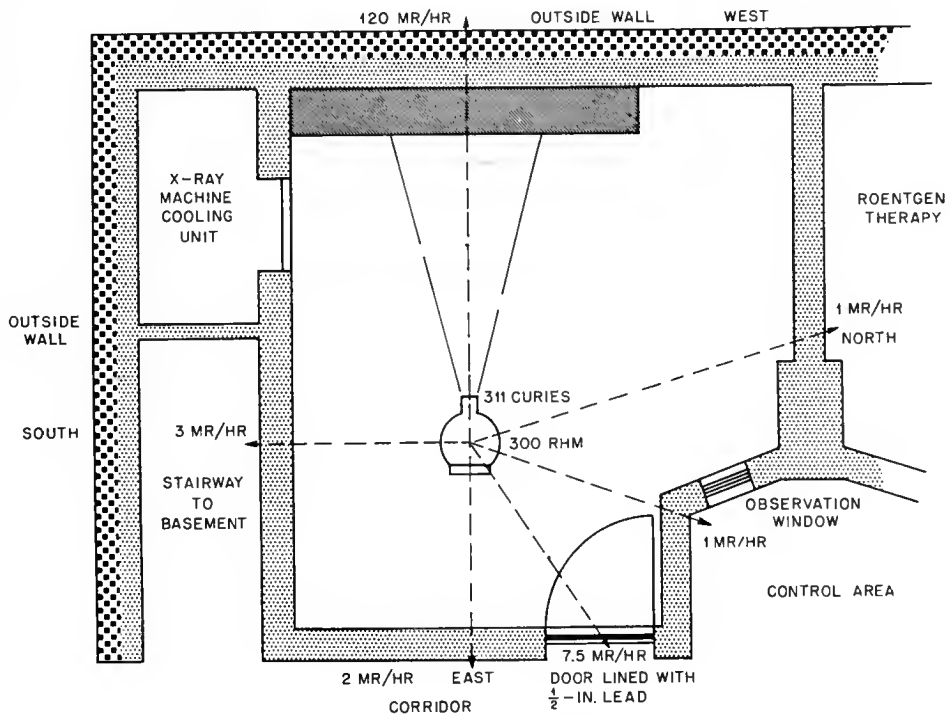

Fig. 7 — Heacock Clinic, Memphis, No. 1 Co^{60} teletherapy laboratory.

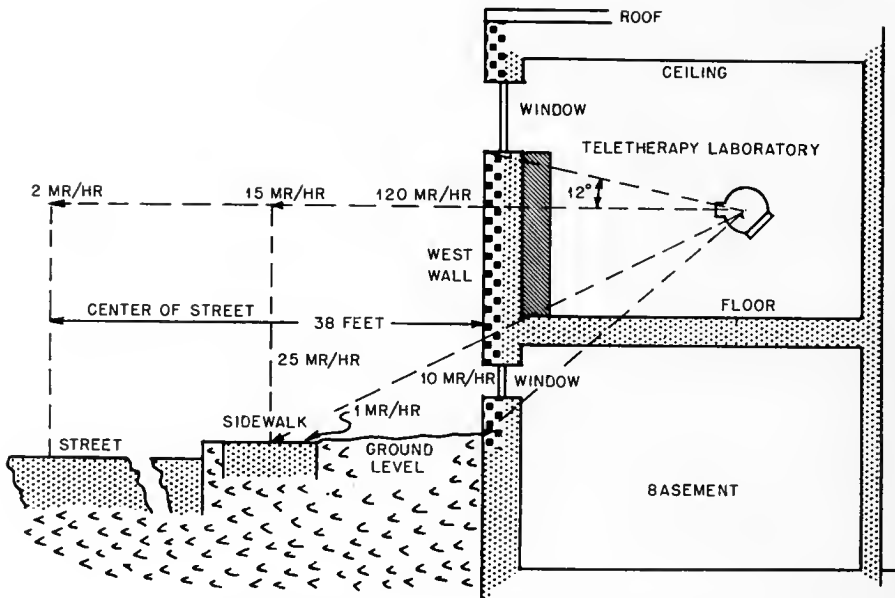

Fig. 8—Heacock Clinic, Memphis, No. 2 Co⁶⁰ teletherapy laboratory.

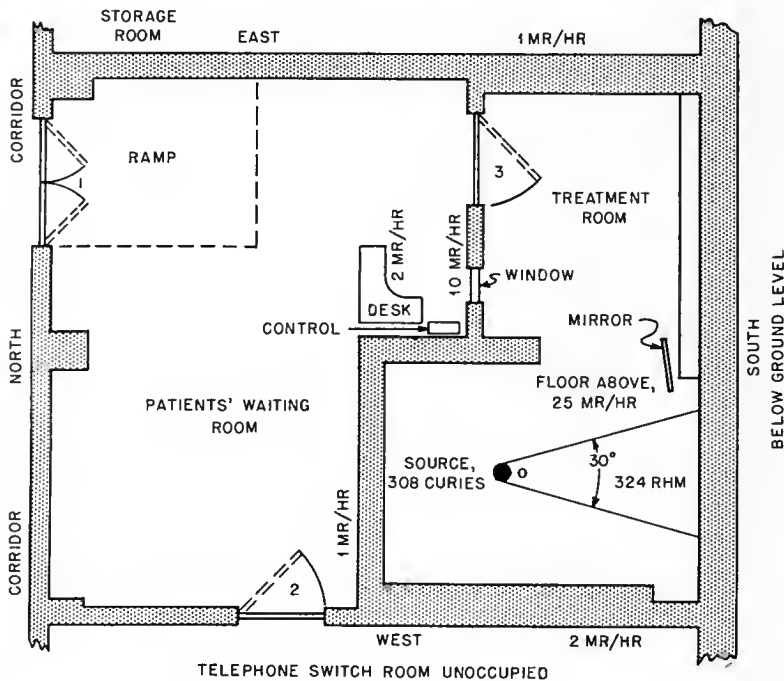

Fig. 9—Gaston Hospital, Memphis, Co⁶⁰ teletherapy laboratory.

INSTALLATION OF Co^{60} TELETHERAPY MACHINES

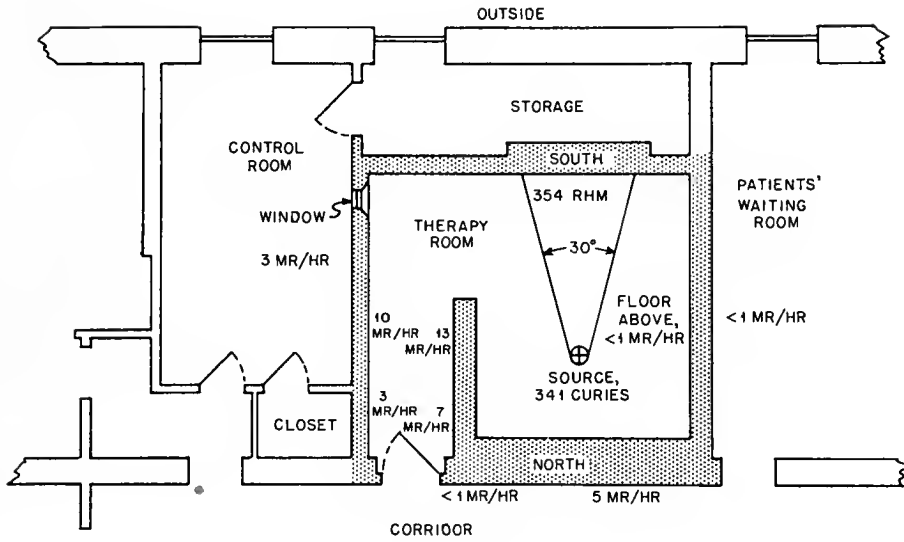

Fig. 10—Detroit Memorial Hospital Co^{60} teletherapy laboratory.

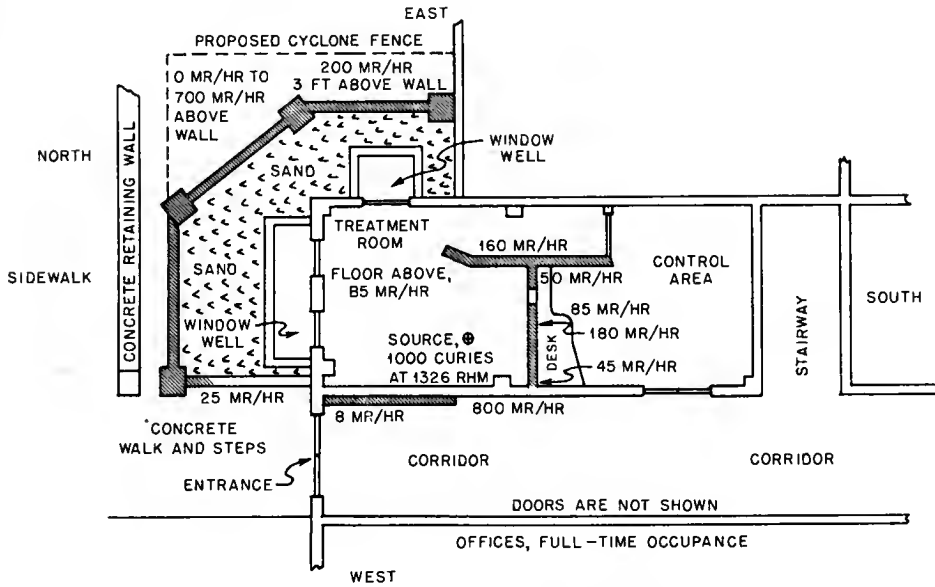

Fig. 11—Louisville General Hospital Co^{60} teletherapy laboratory.

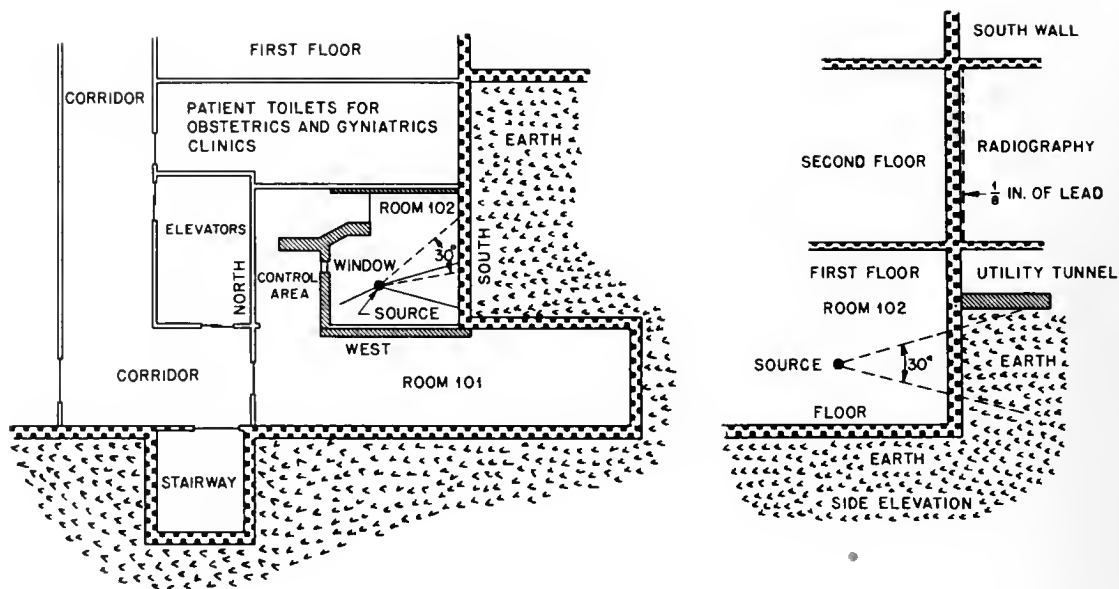

Fig. 12—Vanderbilt University Hospital Co⁶⁰ teletherapy laboratory.

Table 1—SUMMARY OF EARLY Co⁶⁰ INSTALLATIONS

Unit	No. of curies	Rhm	Rhm/curie	Size of treatment room, ft	Cost			Special problems
					Unit	Source	Installation	
Kerman	979	1350	1.4	18 × 16	\$19,700	\$ 8,037	\$ 3,985	Temporary location
Simon	306	420	1.4	9.5 × 13	20,800	1,830	10,000	Densely populated area
Weens	294	360	1.2	10 × 12	10,200	2,800	2,000	Remodeling of large room
Loistrom	341	360	1.1	15 × 19	19,700	2,205	15,905	Complete remodeling of old building
Carroll (1)	311	315	1.0	9 × 18	20,000	2,055	900	Remodeled 250-kv room
Carroll (2)	309	309	1.0	14 × 16	20,000	2,045	450	Changes to new construction
Meschan	1089	1350	1.2	9 × 13	19,700	9,012	717	Remodeled 400-kv room (temporary)
Rubinfeld	599	762	1.3	15 × 15	20,000	4,632	100	Remodeled radium pack room
Jacobs	744	945?	1.3?	12 × 19	32,000	8,200	11,624	New construction
Jaffe	1066	1440	1.4	13 × 13	10,000	8,820	42,000	Special protection for other work
Oak Ridge (1)*	209	232	1.1	14 × 14				
Oak Ridge (2)	963	1160	1.2	14 × 24	26,000	19,000	22,000	
Oak Ridge (3)†	454	360	0.8	14 × 24				

* Experimental source in Oak Ridge unit 2.

† Experimental source in prototype hectocurie machine.

about typical Co⁶⁰ installations is that there is nothing typical about them. The cost of the source of Co⁶⁰ is now standardized and can be calculated before its

additional column of figures for each of these machines, and this is probably the most important item in deciding on the economics of Co⁶⁰ teletherapy. This

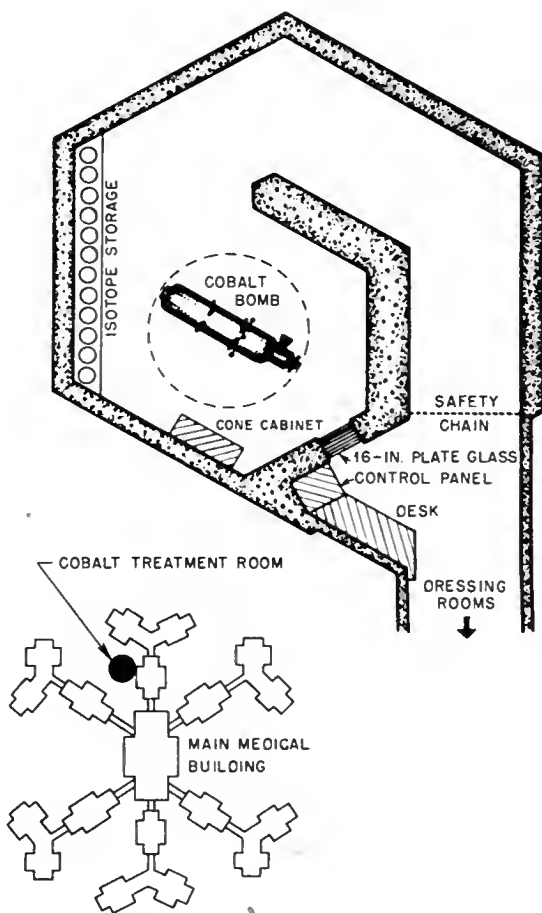

Fig. 13—City of Hope Medical Center radioactive cobalt teletherapy unit at Duarte, Calif.

purchase. (In August 1957, the Atomic Energy Commission reduced the cost for the second time.) The manufacture of the machine is now a commercial item, and its cost can be calculated. However, a very important part of the cost of a teletherapy unit is the installation cost, which we cannot calculate or predict since we have not yet seen a typical installation. Therefore the total cost of a Co⁶⁰ installation is almost completely unrelated to the costs that we can predict in advance. Table 1 summarizes pertinent data of early Co⁶⁰ installations. We should have one

is the maintenance cost of the machine after it is installed. Many therapists who now have Co⁶⁰ machines are collecting actual annual cost figures on this maintenance problem. It would appear from preliminary data that the actual cost of Co⁶⁰ teletherapy is much lower than the cost of any other kind of supervoltage therapy and even lower than the cost of conventional 250-kv X-ray therapy. However, there are still too many unknowns in the formula. In about 10 years we hope to have some idea of how these costs compare with those of conventional installations.

DISCUSSION

CHAPTER 21

Riemenschneider: With the advent of the legal requirements, which Dr. Scott has so ably covered [see Chap. 62], and with the uncertainty about future legal requirements involved in protection, as well as the public scare that has resulted from the report of the National Academy of Science, it is possible that legal requirements have been set below what is recognized as maximum permissible dose today. We must consider adequately the possibility that permissible exposure of nonradiologic personnel may be cut considerably more.

What is the position of the radiologist, and what are his requirements in planning a supervoltage installation? He needs an adequate-sized room and free mobility of the unit. If the unit has a built-in primary protective barrier, it should be possible to use the unit in certain positions without the primary protective barrier. There should be certain safety switches to prevent operation of the unit in positions other than safe ones if the protective barrier is displaced.

In new construction it is better to build underground or at ground level. As Mr. Braestrup has shown, in locations aboveground it is extremely difficult to protect adequately without a built-in primary protective barrier.

Considering potential new developments in equipment, a room should be planned to provide for an increase in output or in the radiation energy. As Mr. Braestrup showed, there is little difference in the primary-protective-barrier requirements with an increase in curiage of the units previously discussed.

One of the biggest difficulties in planning rooms for cobalt teletherapy is that, at the time the room is built, it is built on a minimum scale with minimum protection. The protection is later found to be inadequate. The increased construction necessary to make protection adequate has brought the room below the minimum-size requirement, and construction must begin over again. This is false economy.

In planning a new radiation therapy department, it is wise to plan so that it will be possible in the future to increase the number of supervoltage units without necessarily increasing the original protection. If possible, the design should be such that two rooms

could eventually be turned into one to accommodate new types of equipment such as linear accelerators.

In conclusion, I think that the role of the radiologist in this situation should be—with apologies to Dr. Ellis for adopting his personality and his nickname—to be a “tiger” with regard to the architect, the hospital administrator, the people who are trying to save a dollar here and there, and convince them that a penny saved today is poor economy when it means a dollar spent tomorrow.

Ferlozza: I have seen many radiological installations over the past several years and have been impressed by some; particularly noteworthy are those designed by Mr. Braestrup and by “the Chief,” Dr. Failla.

I wholeheartedly agree with the recommendations of Mr. Braestrup relative to the protection and installation of supervoltage equipment—with everything but the term “supervoltage.” Rather than reiterate what has been said, I shall outline the characteristics of a set of tentative plans for housing a Co^{60} teletherapy apparatus, which seem pertinent to this discussion.

Figure 1 shows the site plan of a proposed building to be added to the Syracuse Memorial Hospital, Syracuse, N. Y. This entire addition is shown crosshatched, with Dr. Riemenschneider’s contemplated department of radiotherapy at the northeast corner. He would utilize two retaining walls and the banks of earth behind them as protective barriers. The approximate location of the intended 1000-rhm Co^{60} teletherapy apparatus is marked “source.”

Figure 2 shows the two therapy rooms in some detail, particularly with respect to protective barriers; the barrier design is based mainly on the following data and assumptions:

A. Teletherapy room

1. Co^{60} source of approximately 1000 rhm in a housing in compliance with the pertinent recommendations of National Bureau of Standards Handbook 54 and further described by the manufacturer as having average leakage in the on position outside the penumbra of the treatment

DISCUSSION

Table 1—ANTICIPATED EXPOSURE IN MILLIROENTGENS

Place (1)	Maximum irradiation, mr/hr					Possible maximum total	
	Useful beam (2)	90-deg scattering (3)	55-deg scattering (4)	On- position leakage (?) (5)	Mr/hr (6)	Mr/week (7)	
Distal side of west wall through:							
Concrete	0.09	0.14	0.5	0.28	0.78 (5 + 4)	16	
3-in. window†	0.68	0.02	0.93	2.2	3.13 (5 + 4)	63	
4-in. window†	0.43	0.0013	0.1	1.4	1.5 (5 + 4)	30	
Roof	0.13	0.15	1.0	0.46	1.46 (5 + 4)	30	
Distal side of south wall							
		0.26	0.024 ?	1.	1.26 (5 + 3)	26	

*Unlikely.

†Made of 55 per cent lead glass.

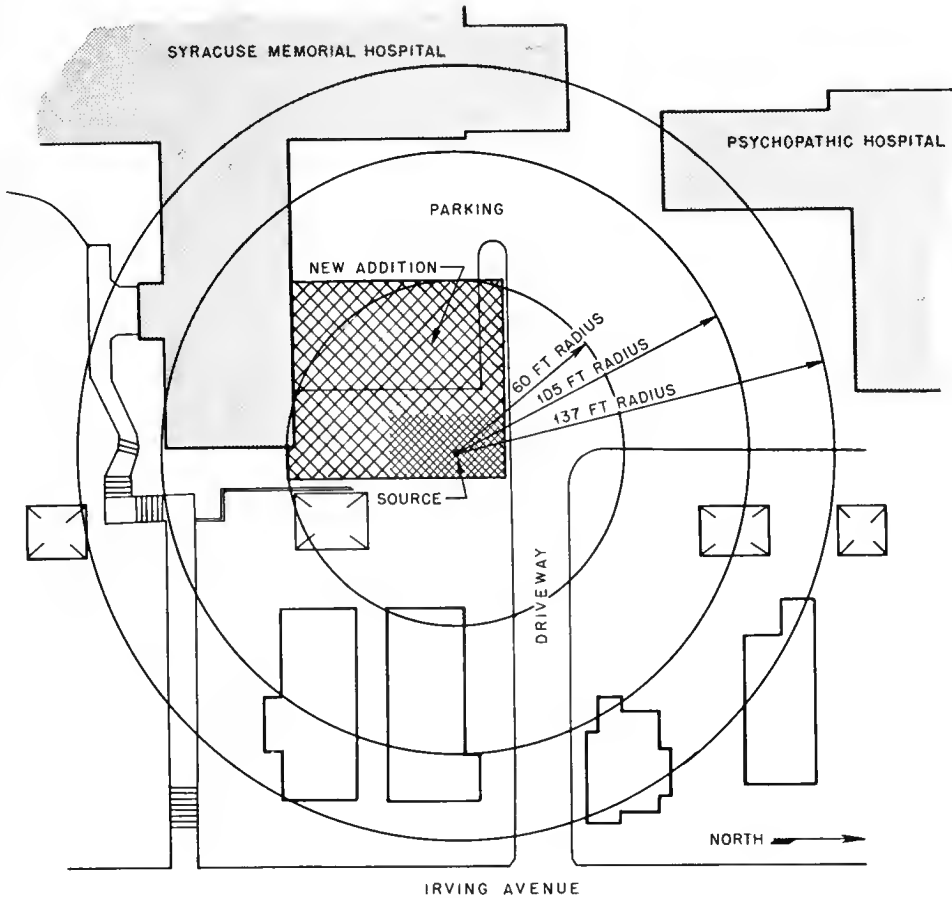

Fig. 1—Site plan of proposed addition to the Syracuse Memorial Hospital.

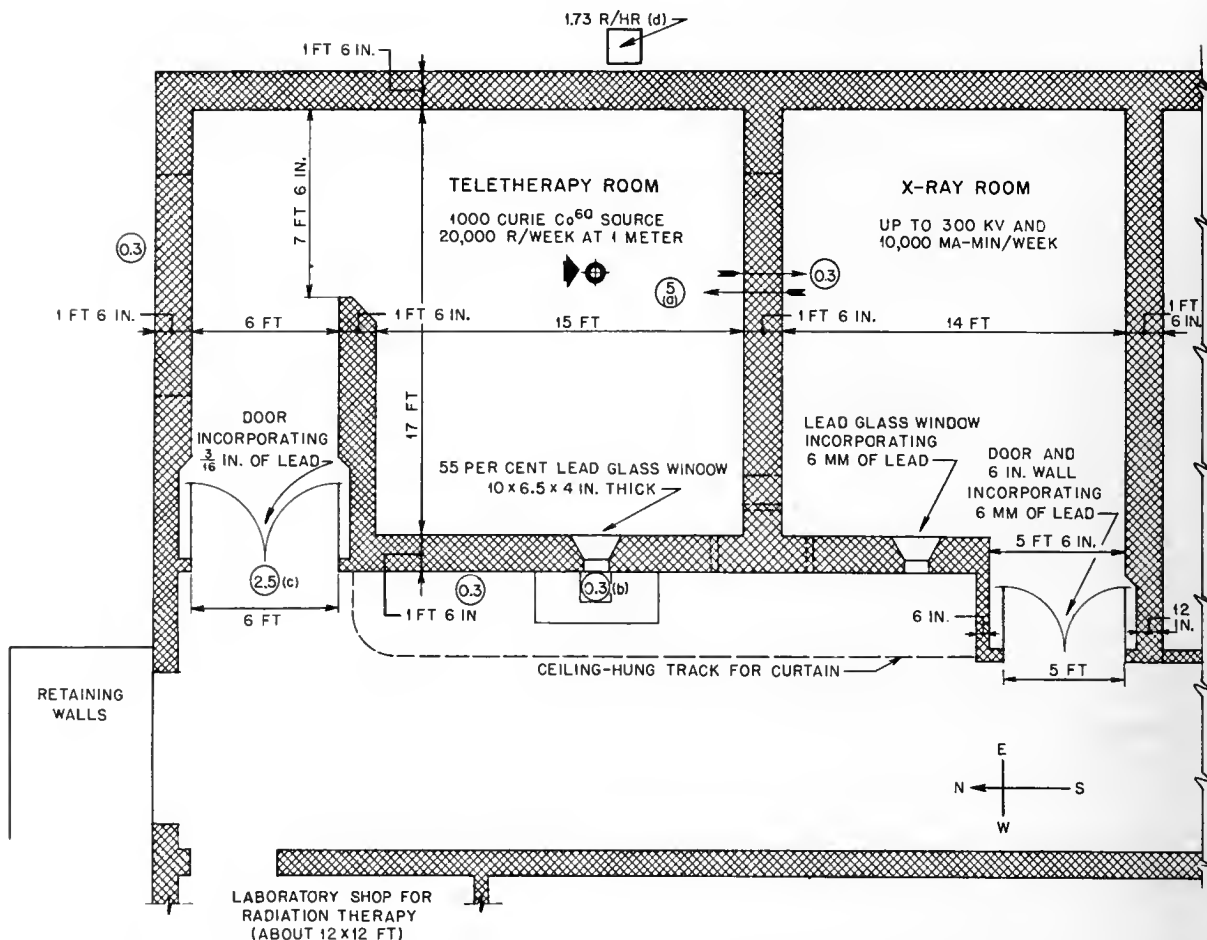

Fig. 2—Tentative plan for radiotherapy rooms at the Syracuse Memorial Hospital. The assumed density of concrete for all walls and roof is 2.35 g/cm^3 (147 lb/cu ft). The roof will be 18 in. thick and will be reinforced to support 70 lb/sq ft in addition to the maximum load otherwise considered. There are to be special conduits and provisions for conjoint use of the teletherapy and the X-ray rooms. The ceiling height will be 11 ft.

- , calculated radiation for the worst conditions, mr/hr.
 - (a) Applies to 300-kv radiation directed toward the common wall (between the teletherapy and the X-ray rooms) from a distance of 8 ft.
 - (b) Applies to 4-in.-thick 55 per cent lead glass window. (For 3-in. thickness, 0.3 mr/hr; for 2-in., 2.1 mr/hr.)
 - (c) Applies to unlikely possibility of the door's being seen by the first scattering of the unattenuated useful beam.
- , calculated radiation for the worst conditions, r/hr.
 - (d) Bank of earth against the east wall and part of the north wall.

field of 0.05 per cent of the useful beam, both measured at the same distance from the source.

2. Work load of approximately 20,000 r/week at 1 meter.
3. Built-in primary barrier of iron with effective thickness of approximately 28 cm for the useful beams; the barrier also catches most of the scattering from the irradiated object within an angle pivoted at the center of the object and varying from 35 to 55 deg around the axis of the useful beam.

4. Apparatus usable apart from built-in barrier only when the useful beam is directed downward and eastward toward the earth banks.
5. Concrete of not less than 147 lb/cu ft.

B. X-ray room

1. No practical limitations up to 250 kv.
2. For 300 kv and 10,000 ma-min/week, the only possible limitations are for the useful beam directed toward the window and the door.
3. With minor changes and a few limitations, the room could be used for hectocurie Co^{60} or the equivalent.

In this figure there are some minor errors. The values that are more likely to be correct are given in Table 1.

Figure 3 is the north elevation showing the slope of the terrain with respect to the retaining walls. At the extreme left of Fig. 3 is a cross section of the main retaining wall running north and south; and the next cross section is that of the parallel retaining wall of the service-emergency entrance and exit.

The results of my preliminary calculation are summarized in Table 1. They are predicated on the data and assumptions already mentioned and on other conditions mentioned earlier and shown in the illustrations.

Column 6 represents the likely level of exposure rate that would be expected under the most unfavorable conditions of irradiation. Column 7 represents the possible level of weekly exposure that would be expected under both most unfavorable conditions and entire work load, approximately 20,000 r/week at 1 meter. Consequently neither the figures in column 6 nor those in column 7 represent concurrent levels of exposure and should be interpreted accordingly.

For comparison, figures for two thicknesses, 3 and 4 in., of the observation window are shown, both of 55 per cent lead glass; however, the 4-in. thickness or its equivalent will probably be used.

So far, any possible economy that might accrue from considerations of occupancy and use factors has not been taken into account because the main purpose is the estimation of the highest exposure rate to be expected, in milliroentgens per hour with the source in the on position, in the areas of interest. Furthermore, there are uncertainties in planning that either outweigh or render some such considerations highly hypothetical, e.g., (1) complete information on the leakage of the housing is not available, (2) the future disposition of the roof and of other areas contiguous to the contemplated installation is still unknown, (3) one can hardly foresee how competitive or otherwise desirable radiation sources other than those herein considered will be a few years hence, and (4) one can only guess probable future changes in radiation protection.

In conclusion, most of Mr. Braestrup's recommendations are incorporated in the plans just outlined.

The radiological designer must (1) understand the problem and the results to be obtained, (2) acquire the necessary data and make supplementary assumptions, (3) decide on the method of attack and derive the desired quantities, (4) check and analyze the results, and (5) make the necessary recommendations and explanatory drawings. In this kind of study he is likely to be concerned with properties and cost of materials, relative cost of labor and materials, degrees of safety, possible future requirements, convenience, and appearance.

The contribution of the radiological designer is appreciably enhanced when he is consulted at the earliest stage of planning. Otherwise he can only

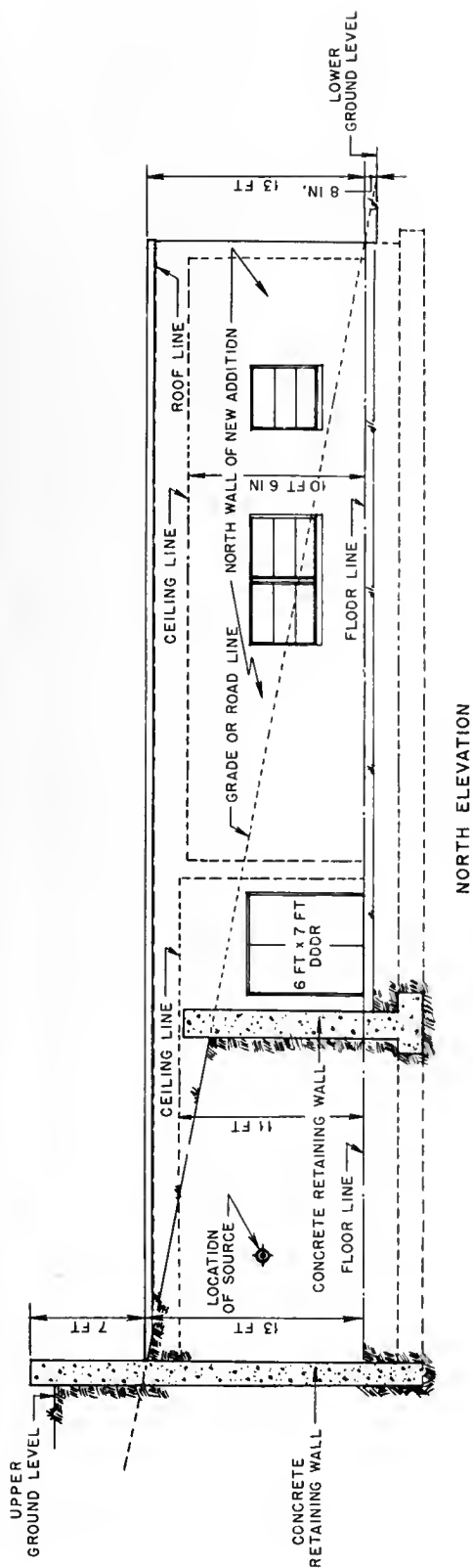
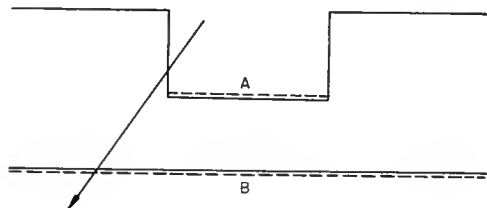

Fig. 3—North elevation of proposed addition to the Syracuse Memorial Hospital.

design protective barriers for conditions that, more often than not, are unnecessarily adverse both functionally and economically.

Benner: Mr. Braestrup has given an admirable survey of all the different factors needed to calculate the protection. I should like to add one detail that may easily be overlooked, the need for overlapping. I shall illustrate this with a junction box set into a wall:



One would be tempted to put the additional lead at A, believing this to be sufficient, but it is not because radiation can penetrate, as indicated by the arrow, and not be sufficiently attenuated. Lead at B, overlapping the full-thickness part of the wall over a width approximately equal to the necessary thickness of the wall, would intercept these rays.

Farmer: I shall discuss briefly the 4 million volt linear accelerator, four of which are now operating in hospitals in England. This machine gives a somewhat harder radiation than Co^{60} but in many respects can be compared; it involves the same kind of building and protection problems as those with which Mr. Braestrup has so ably dealt.

The choice of 4 million volts was based on a decision that the machine would be mounted on a gantry, allowing the source of X rays to be moved in an arc around the patient, always directed to a fixed point in the body. This limited the length of corrugated wave guide to about one meter (Fig. 4). The resulting voltage, though much below the maximum obtainable with linear accelerators, is well in the supervoltage region, and I am personally not convinced that a higher voltage gives any substantial advantage for X-ray therapy.

Figure 5 shows the general layout. The machine is mounted on bearings at opposite ends of the treatment room, and the couch is supported on a single pillar, its horizontal movements in two directions at right angles being provided in the upper platform. This arrangement allows arc therapy by rotation of the gantry or cone therapy by rotation of the couch. The vertical axis of the couch pillar and the horizontal axis of the machine intersect the central ray of the beam at a fixed point in the room, the focal point; this point is 100 cm from the target. The ceiling height for this machine is 14 ft.

I should mention that this arrangement allows an alternative and in my view a more important use of the mounting, namely, ease in setting up fixed fields. For this purpose the focal point is made to coincide with a skin-entry point (not with the tumor), and the subsequent adjustment of gantry angle and couch orientation enables the emergent ray for any given

field to be brought quickly to its appropriate point on the patient by two independent movements. Compared to earlier types of deep-therapy apparatus, the convenience of this form of movement is very great. Figure 6 shows the machine with its entry and emergent ray pointers used in this way. Normally the forward pointer is replaced by a four-beam optical range finder giving centering and distance.

The dose rate at 100 cm focal-to-skin distance (FSD) is 100 r/min, or higher if desired. The focal spot is 5 mm in diameter, and the beam-defining diaphragms (4 in. of lead) are pivoted at target level (Fig. 7); thus their inner surfaces always lie tangential to the beam. This results in an extremely sharp cutoff of radiation, and the penumbra is about 5 mm in width at the skin and only 8 mm at a depth of 15 cm.

I believe the linear accelerator, by virtue of its high output, ease of setting up, sharply defined beam, and inherent safety when the X rays are off, has real advantages over the Co^{60} machine and is likely to become a more widely used machine in the foreseeable future.

Scott: We had several plans drawn for our setup but were wise enough to send them to Mr. Braestrup for his approval, and therefore we gained some very acceptable ideas from him.

I urge you to keep all your measurements within the dose permissible for nonoccupational personnel. Having just undergone the experience of getting a regulation altered, I think it behooves one to lower the dose measurements a little more than the minimum requirements because, as has been pointed out already, they may be changed and it is very difficult to remedy such a situation.

I also urge you to keep the supervoltage and radiation departments on the ground floor or, preferably, below ground. Those in private practice may benefit when a new medical building is being constructed by obtaining a suite on the first floor for diagnostic work and putting the therapy department in the basement; during construction adequate concrete barriers can be built with little additional cost.

We solved our problem in this way. It permitted us to build in our cobalt rooms at an economical figure, and, consequently, we can get along without subsidization. This is a very important consideration in private practice.

Second, I would urge that you provide sufficient protective barriers for several rooms in order that they may accommodate additional facilities for more teletherapy rooms. Whether it will house your old 200-kv machine and whether the adjoining room will contain your superficial therapy unit, all your rooms should be prepared for cobalt. The time is coming when our present source will be weak, and we shall want to obtain a kilocurie source that is down to about our 600-curie level. Our old 600-curie source will be put into a 300-curie source, and we may want to continue down to about a 100-curie source.

Without such provisions, I do not know what you can do with secondhand cobalt as it loses its strength.

DISCUSSION

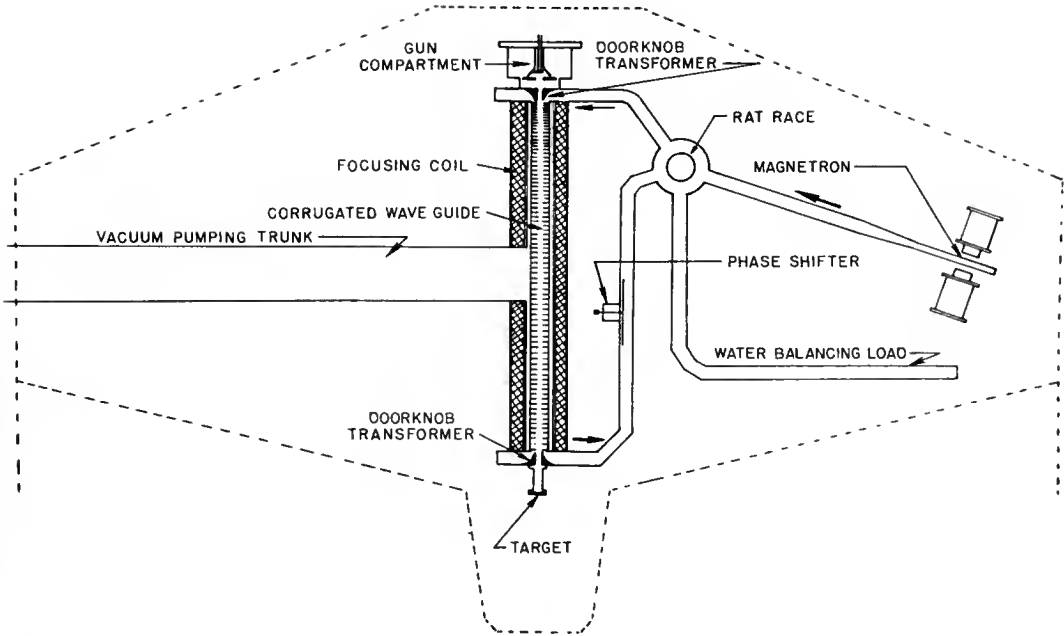

Fig. 4—The 4 million volt linear accelerator at Newcastle on Tyne, England, showing the corrugated wave guide 100 cm long, the power supplies from the magnetron, and the electron gun arrangement.



Fig. 5—The 4 million volt linear accelerator mounted on two main bearings, with its single-pillar couch. The movements are designed to facilitate the setting up of fixed fields (with or without an emergent ray pointer) and to allow rotation of the machine about the tumor.



Fig. 6—The 4 million volt linear accelerator with entry and emergent ray pointers. The entry pointer is normally substituted by a 4-beam optical range finder.

Perhaps it can be returned to Oak Ridge for recharging or perhaps it can be sold. The best solution to this problem is to prepare all three rooms to be used interchangeably.

I would also urge you in the planning of your therapy rooms to give them the dignity of medical treatment rooms and not to decorate them like a parlor or someone's living room. I think that creates a false impression on patients. The rooms can be attractive without window dressing.

I also urge you to supply extra electrical conduits in the walls and in the floor for any accessories that may be developed in the future. It costs so little to put in the conduits during construction, but it costs so much to put them in after the room is finished.

Tice: What is your idea about piped-in music?

Scott: I do not object to piped-in music as long as it is being used elsewhere; but I do not like the idea of having it exclusively in the teletherapy room. One of the great advantages of teletherapy is that it is quiet, and the patient experiences peace and comfort in the therapy setups. There is no roar or hubbub, and it is rather nice to maintain this atmosphere.

Tubiana: To protect an area at a particular distance from a source, a shield of a certain thickness corresponding to a certain number of half-value layers (HVL) is needed. If the shield is put far from the source, it will cost and weigh much more than if

it is put near the source. The nearer the shield is to the source the less weight is needed, although the thickness of the material used is the same. This could be an important consideration when weight is relevant. A shield of lead would weigh less than one of concrete.

I can say a word about our personal experience with a betatron. After the room was built, we found that the protection was not sufficient. Our first idea was to add more concrete to the wall, but before this we tried to improve the primary shielding. We built a wall of X-ray films around the lead primary shielding. (It was a kind of autoradiography of the protecting wall.) We detected in this way a few spots where protection was inadequate. With a few pounds of lead or lead rubber located near the source, it was possible to economize tons of concrete on the walls.

Simon: The problems of protection which had to be answered in our installation were taken care of by Mr. Braestrup, and we are pleased with that aspect. However, one accidental advantage occurred, and I wonder if it has been thought of by the designers and manufacturers of machinery.

For instance, we have the Keleket-Barnes tube-stand machine; the beam is directed into a corner, the observation window for the controls being in the opposite corner. The tube stand contains counterbalances of lead located between the useful beam and the control area, and protection for the control area takes advantage of these lead blocks.

DISCUSSION

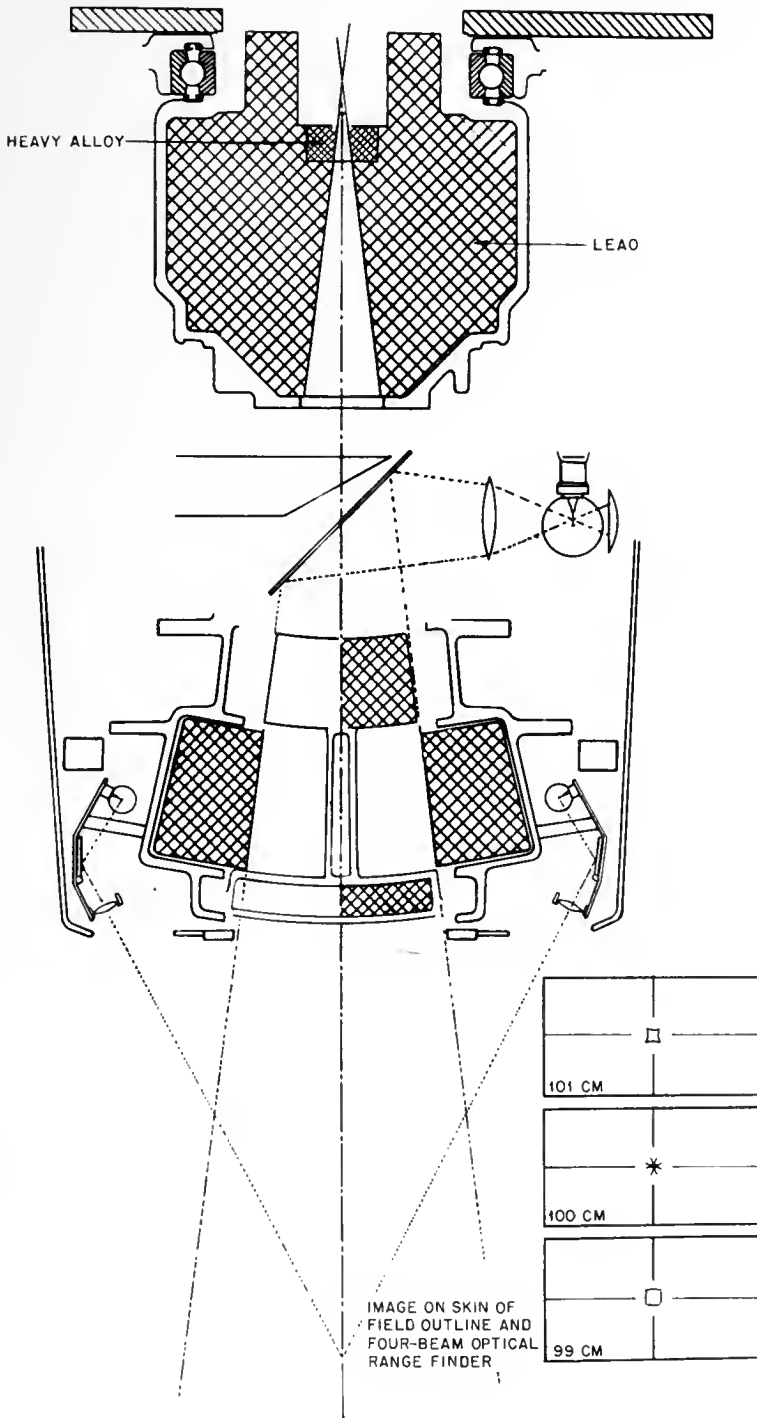

Fig. 7—The 4 million volt X-ray head, showing pivoted diaphragms to minimize penumbra and optical systems to center and outline the beam.

If these lead blocks, which counterbalance the heavy head or source shield, were lead plates instead of blocks they could represent added protection for a critical wall. The lead plates would move up and down with positioning of the source head. The least favorable position of the direct beam for scatter radiation at the walls of a cobalt room is vertical, and, when the beam is vertical, the source head will be in a relatively high position. In this high position of the head, the lead plate counterbalances on the wall will be correspondingly low. When the beam is horizontal and the head is low, the counterbalancing lead plate will be high, but with this position the requirement for added protection of the walls from scatter is lessened.

This use of the counterbalance of lead could serve as added protection for increasing the safety factors in the installation of cobalt.

Stober: One of Mr. Braestrup's first slides showed a stationary unit in an upper story with the full primary-beam concrete barrier right in the floor. I wish he had stated the additional weight that had to be supported in the building. I have been disturbed by the number of tons that must be held up in the air when the full primary shielding is placed in the floor.

This has led to an appreciation of the primary-beam absorber as an extremely efficient device, and I have always given Mr. Braestrup credit for this attachment to a teletherapy machine. Any machine in an upper story should have a primary-beam absorber, and for best efficiency, from a standpoint of both cost and weight to be supported in the building, the beam should be restricted to the primary-beam absorber.

Nurnberger: I have helped install a number of cobalt units and should like to report the results of a survey of personnel working in these units.

I collected data on four of these units. The installations were planned on the basis of a permissible dose of 300 mr/week with a 40-hr total on time for the unit, making a 7.5 mr/hr permissible dose rate. We calculated the barrier thickness on the basis of the National Bureau of Standards Handbook and added 25 per cent to the calculated thickness. In none of these four installations did the maximum exposure to personnel exceed 60 mr/week. In three it was below 40 mr/week, and in one it was about 60 mr/week.

If 300 mr/week calculated on this basis is permissible, then these units have sufficient protection. However, the dose rates have not been decreased to the levels that Mr. Braestrup mentioned.

Loevinger: I suggest that where space is at a premium, we are not justified in making the walls thicker than current regulations plus a reasonable safety factor would require. Where space is short, there is a better method of anticipating future requirements than making walls unnecessarily thick. This is to reinforce the floors so they will support heavier walls than those initially installed. Then concrete brick can be set in at a later time to bring the protection up to later requirements. This comment particularly

applies to a maze for protecting a door, which is a particularly difficult thing to compute. If the floor is properly prepared ahead of time, one can easily install or improve a maze by adding concrete bricks where and as needed.

Supervoltage protection calculations are at the moment by no means as easy as they sound because adequate information is not presently available. The manufacturers are remiss, as has been pointed out, in not having supplied us with a good polar diagram of leakage radiation for each machine. The physicists are remiss in not having provided adequate scattering and attenuation data. Some of the data that are greatly needed I have seen for the first time on the screen at this symposium. Certainly we are most grateful for the work of C. B. Braestrup and R. T. Mooney, who have given us some of the needed data in just the right form, i.e., attenuation data as a function of angle relative to the intensity of the primary beam.

The data presented here are for once-scattered radiation. To calculate measurements for a maze, we need data on multiple scatter for each one of the supervoltage radiations. It is important to set up a protection standard, e.g., 2 mr/hr, but we cannot attain it without adequate basic data.

Much of the literature on supervoltage protection is presented in an awkward fashion. Layouts of existing establishments, with measured radiation levels, are not very useful when it comes to an entirely different layout. It is difficult or impossible to transfer such information to one's own blueprints because of difference in room size, occupancy factor, use factor, number of contiguous treatment rooms, leakage radiation, etc. Only an adequate presentation of the basic scattering and attenuation data will make possible good, economical, and sensible protection calculations. I hereby make a plea for a systematic preparation of such data.

Smithers: I think it is important that there be another column at the end of Dr. Brucer's table [Chap. 20]. Dr. Flanders in England did some useful calculations on this subject. He calculated the cost per thousand roentgens at a depth of 10 cm. Many factors can be added into this. With the higher output machines intensity becomes decreasingly important because the time spent in the change-over of patients sets the pace. In considering economics I think it is important to reckon on the amount of work the machine is able to do. This factor puts the linear accelerator, for instance, in a better economic light.

Scott: I wonder if Dr. Farmer would give us an idea of the cost of their linear accelerator.

Former: The cost in England is approximately 50,000 pounds; convert that to dollars.

Brucer: One hundred fifty thousand dollars.

Freid: We had a quote about a year ago on a 4 million volt linear accelerator from the High Voltage Engineering Corp., Cambridge, Mass., of about one hundred thousand dollars.

Section E

Sources of Energy

Galen M. Tice
(presiding)

Source Production by Atomic Energy of Canada, Limited

CHAPTER 22

C. H. Hetherington

Atomic Energy of Canada, Limited
Ottawa, Ontario, Canada

The cobalt target material we use in our program consists of 1- by 1-mm cobalt pellets. These are cut from 1-mm-diameter wire by the cobalt supplier. We chose these small pellets to get more versatility in the make-up of sources. There are advantages and disadvantages in using them.

These pellets, when received from the supplier, are coated with a thin layer of graphite, which is from the wire-extrusion process. They must be degreased and outgassed before irradiation; otherwise, after irradiation the capsules are seriously bulged and consequently cause handling problems.

After the cobalt has been treated in this manner, it is placed in our standard irradiation containers, which are about $1\frac{3}{4}$ in. high by $\frac{3}{4}$ in. in diameter; we use an annular portion of the capsule in which to place the pellets.

The reason for this is the irradiation efficiency or flux attenuation in the reactor, which is the same general principle as gamma-ray attenuation. In other words, if the capsule were completely loaded with cobalt, the material in the center would be practically inactive owing to neutron attenuation.

In a 3-mm annular-ring configuration, for example, there results about 50 per cent of the activity that we would originally calculate. This is again irradiation efficiency; we get about 50 per cent of the activity one would expect if there were no cobalt there in the first place.

We put about 30 g of pellets in each capsule and place them in what we call calandria-tray rod positions. They are irradiated at a flux of 3 to 6×10^{13} neutrons/cm²/sec, and the specific activity, on the average, increases at about 2 curies/g./month. Therefore, to get 35 curies per gram of material, it takes about 17 to 18 months in our present NRX reactor.

The sealing of these capsules is done by the cold-weld process. There is a lip on the end of the capsule, and an aluminum lid is placed on this end. The capsule is put in a die that exerts pressure to produce a cold-

weld sealing process between the two surfaces. These capsules will stand internal pressures up to 500 psi at normal temperatures.

After the irradiated capsules are removed from the reactor, they are placed in a drawer, which is similar to that in beam therapy units. The drawer is in a large case and is flush with the edge. The transfer case is, in turn, butted against a large cell, where it is loaded into the International Standard Capsule. A vibrator system is used for this, operating so that the pellets can be loaded one at a time, if necessary.

The cobalt is weighed and the capsule is measured as it comes out of the reactor. From this information the amount of cobalt that should be put into the capsule to give a certain output is calculated.

We have adopted the policy of selling our sources on the roentgen-output basis. I think the term roentgen is correct in this instance since it is measured in air. It is therefore necessary to measure the output of each source before shipping it to the purchaser. Originally, when we were using only our own teletherapy machines, there was no particular problem because each source would be measured in the machine, and that was the dose rate the doctor or radiotherapist could use.

Since we now supply sources to many manufacturers and since we have sold a number of units, we have had to adopt a standard measuring apparatus. For the past year we have used an Eldorado unit complete with diaphragm, and all measurements were made by the National Research Council (NRC) of Canada. The source is placed in the Eldorado unit, the measurement is taken, and the roentgen output is established at 1 meter. This is written on the certificate, and the measuring conditions are given.

At the present time we are collaborating with the NRC in the design of a different type of standard measuring facility with which all the measurements will be made automatically. The drawer will be placed into the measuring apparatus, and the equipment will

automatically give the reading. When the source is received, all the conditions of measurement will be written on the certificate.

Nevertheless, it certainly will be necessary for each physicist to remeasure the source in his own equipment because the output will vary owing to different configurations of diaphragm arrangements.

We can give some actual figures on Canadian cobalt production. This year (1956) from NRX, which is the reactor presently operating, we hope to produce 60,000 curies of 25 to 35 curie/g material.

In 1957, from NRX we hope to obtain about 70,000 curies of the same type of material, and from NRU, which is the new reactor that will be in operation in

January of 1957, we hope to produce an additional 60,000 curies of perhaps 50 curie/g material. Thus the total production in 1957 should be 130,000 curies.

From 1958 on, we hope to produce between 300,000 and 400,000 curies of cobalt of up to 100 curie/g material. This is the present outlook. The production from NRU, of course, will depend on the first few months of operation. The reactor physicists are always optimistic, and I hope they are correct.

We have been doing a lot of estimating, or attempting to estimate, of cobalt supplies in the next few years, and we believe that over the next three to five years there will be an adequate, or perhaps even more than adequate, cobalt supply for teletherapy units.

Source Production by U.S. Atomic Energy Commission, Oak Ridge

CHAPTER 23

J. H. Gillette

Oak Ridge National Laboratory
Oak Ridge, Tennessee

At the Oak Ridge National Laboratory (ORNL), we are supplying teletherapy units in the International Standard capsule in two inserts. The only difference between these inserts is that one will take 1-cm-diameter material and the other takes 2-cm-diameter material. The 1-cm-diameter wafers are either 1 or 2 mm thick. The 2-cm-diameter wafers are 1 mm thick.

The clover-leaf, or 1-cm-diameter, insert was originally intended for use with some slugs that were 1- by 1-cm right cylinders. We have since discontinued irradiation of these slugs, and we now use the source holders with the 1-cm-diameter wafers.

Originally we gold-plated all cobalt prior to irradiation. We still have some gold-plated cobalt. Perhaps there is some still to be removed from the reactors. At the present time all cobalt inserted for irradiation is nickel-plated because this will give a better plate and better protection against contamination.

The situation with irradiations in the United States is somewhat different from that in Canada. We prepare approximately the same amount of cobalt in each can that the Canadians do. The major difference is that we use wafers where they use small pellets. After irradiation the cobalt is shipped back to us and stored until we can assay it. We have a shielded facility in which we can handle up to 10,000 curies of cobalt at one time. As soon as possible we open the cans in which the material was irradiated; we remove the wafers, give them a rough monitoring or assaying, and store them in underground pipes.

The material remains in these pipes until we are ready to load cobalt sources for individual customers, at which time we make a guess about the number of wafers we need for a particular source. Then these wafers are again assayed.

All sources shipped out are prenumbered so that we can maintain a history on each source. This history gives the total activity in the source, the number of wafers used, and the outside contamination at the time the source was shipped. If any customer has a

question at some later date, we can check the records fairly rapidly.

Our assaying equipment was originally calibrated by using two pieces of cobalt with the same physical dimensions which gave the same relative reading on our assaying equipment. One of these wafers was then dissolved and counted by normal counting techniques; the second piece of cobalt was saved for use as a calibrating source on our equipment.

Frequently we use our standards to check our assaying equipment; thus we feel fairly certain that the number of curies shipped is accurate within ± 10 per cent and certainly within 15 per cent.

At the time we originally calibrated our equipment, we used an *r* meter to check the readings. I have forgotten the exact figure, but it was within about 1 per cent of the counting-technique method.

After we load a source, we wipe it clean and smear it. All the sources shipped to date, with possibly some exceptions, have been less than 1/mr/hr on the surface.

Concerning the number of sources shipped since we began selling teletherapy units, we have sold 22 clover-leaf sources (1 cm in diameter). We have sold 33 stack sources (2-cm-diameter material).

More than 11,000 curies of activity have been shipped in the clover-leaf sources, and more than 47,000 curies, in the stack sources. In the last year we have shipped 10 clover-leaf and 20 stack sources. This represents about 5800 curies in the clover-leaf and 28,000 curies in the stack sources.

We are now irradiating cobalt in the Materials Testing Reactor, Idaho Falls, Idaho, at Savannah River, S. C., and at Hanford, Wash. Currently the supply of cobalt appears to be adequate to satisfy the demand for sources. Another six months to a year is needed before we can be sure that we are producing enough cobalt to supply the anticipated demand.

Delivery is now more or less on a routine basis. Cobalt is not discharged at regular intervals from the reactors, and therefore some short delays may result;

but delivery is dependent upon the time we receive purchase orders and shipping containers.

We have only one large loading facility, which is also used for processing other material. This facility is rather busy, and therefore we have the problem of scheduling the loading along with our other work. However, this will not delay shipments appreciably.

In regard to the International Standard capsule, we believe that it does not provide a really good seal. We are currently working on the design of a new capsule, which will be similar to our cesium capsules. It will be a double-walled affair—two cans, one inside the other—and each can will be welded closed separately. As soon as this design is completed, we hope to get comments from various people; it is our thought that this capsule will be of such a size that everyone can use it. We would supply the double-sealed container and then load this container into any other container the customer may want.

Mr. Beauchamp suggested that I say a few words about our relationship with the Atomic Energy Commission (AEC). I am a Union Carbide Nuclear Com-

pany employee. We are charged with operating the laboratory; we have no direct relationship with the Civilian Applications Group in the AEC; they are strictly AEC employees, and their responsibility is to issue the licenses. It is our responsibility to supply the material and to load it for the customers.

Any time you have questions about licenses, you should go directly to the Division of Civilian Application, Isotopes Extension, Oak Ridge, Tenn. If the questions are about the cobalt that is available, how much it will cost, or what kind of equipment we would be able to handle, I suggest that we be consulted.

Concerning cesium production at ORNL, the amount of Cs^{137} is still very limited. We are currently building a pilot plant, which we hope to place in operation approximately one year from now [July 1957].

The capacity of the plant is 200,000 curies/year. Once this rate is attained, we shall be in a position to supply either radiographic sources or teletherapy cesium sources. Mr. Beauchamp's group is currently working on a standard design for a cesium capsule.

World Production Estimates

CHAPTER 24

Marshall Brucer

Medical Division
Oak Ridge Institute of Nuclear Studies
Oak Ridge, Tennessee

Mr. Hetherington talked about Canada; Mr. Gillette talked about the United States; I must include the whole world in my discussion. Also, it should be pointed out that I am the one person in this room that can stick his neck out just as far as "Uncle Miltie" Friedman can. To form the basis for an argument, I shall make some wild assumptions. There will be plenty of time in the discussion for you to chop at will.

Figure 1 illustrates the status of Co^{60} production. Depending upon whether one is a Canadian, an American, a Russian, or even an Englishman, Co^{60} production started (for teletherapy purposes) in one of these countries. I have selected 1951 as the first year in which Co^{60} was produced for teletherapy; however, as time goes on, the date of the first Co^{60} machine goes back further and further in history.

There should be a rubber scale on Fig. 1. Almost everyone now has priority on the production of the first Co^{60} machine. I have in my files of newspaper clippings the absolute proof of at least 50 "first" Co^{60} machines. All these people are liars, of course, because we had the first machine.

At any rate, by 1952 a few additional Co^{60} sources were in operation in the United States. In Fig. 1, the Canadian and American production of Co^{60} is placed on a semilog scale. We place the Canadians on the bottom to make their production look bigger than the American production. This is done because we are naturally polite.

Actually, in the first few years production was about the same. If we analyze the total number of Co^{60} sources installed in teletherapy machines during the first six years of production, we see a nice exponential increase.

All that is necessary is to project this to find out what will happen by 1966. In this era of prediction by extrapolation instead of crystal ball, this should permit an extrapolation to a saturation level for the use

of Co^{60} in teletherapy. This saturation level depends upon where you put the ruler when you draw the straight line, and so it appears that the annual production will be somewhere between 2 million and 4 million curies of Co^{60} . We need another estimate of what the saturation levels might be in about 1966 because by that time equipment manufacturers, who eventually will be handling all sources, will force their salesmen off their chairs to actively sell Co^{60} .

Three estimates have been made independent of this kind of graph. One is my estimate, which places the saturation level at about 4 million curies production per year; another is the Canadian estimate of a saturation level of about 2,500,000 curies annual production; the third estimate was made by a commercial manufacturer for the United States alone. Again the figures for the saturation level come out somewhere between 2 million and 4 million curies.

Figure 2 shows where the machines have been installed up to June 1956. Two circles are placed in each country where it is known for sure that a Co^{60} machine exists. The first circle (left) contains the number of Canadian sources in operation. The second circle (right) contains the number of United States sources in operation. These figures are very difficult to obtain, and it cannot be expected that they are completely accurate; however, the figures are adequate to illustrate what is happening throughout the world.

In Canada there were 12 Canadian sources and apparently 4 United States sources in operation in June 1956. In the United States there were 20 Canadian sources and 44 United States sources.

The Japanese sources constitute a special case. Apparently Japan has placed two large orders, one with Canada and one with the United States. These sources were used in Japanese-made machines, and it appears that in June 1956 there were about 20 machines either in operation or very shortly to be put in operation.

When these are totaled, it appears that there were about 54 United States Co^{60} sources and about 44

[Editor's Note: As of August 1957, the Atomic Energy Commission reduced the cost of Co^{60} and increased potential production.]

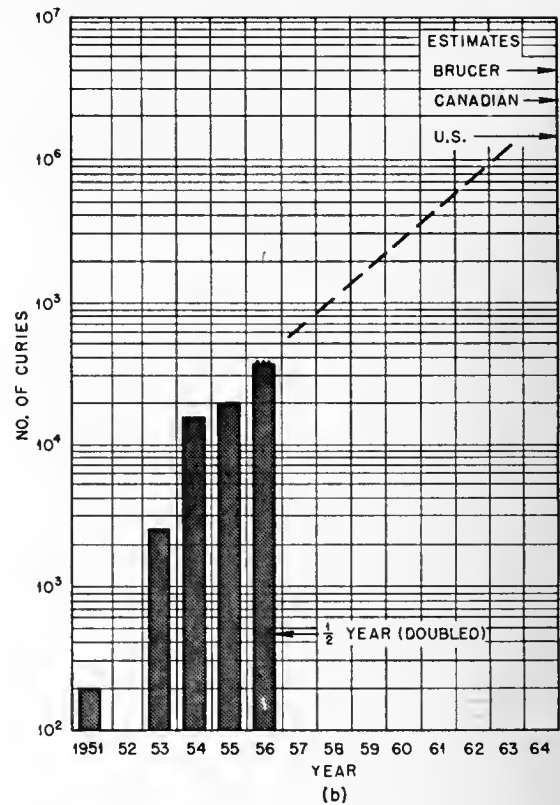
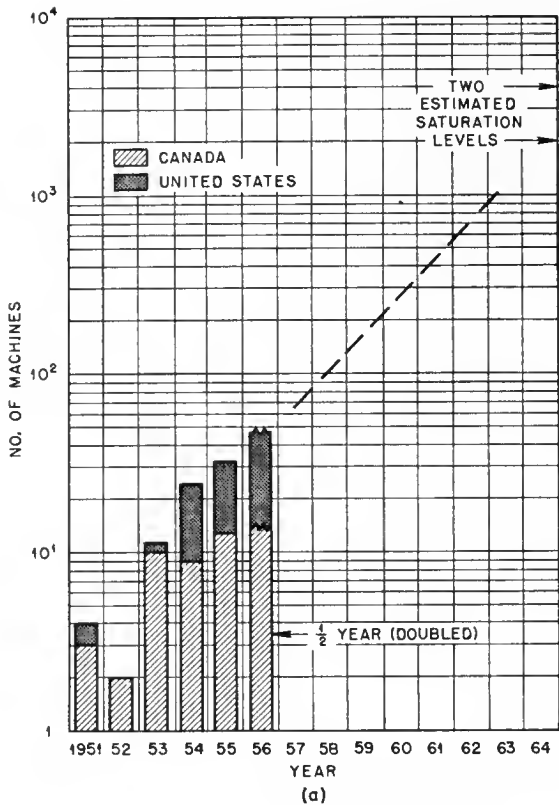

Fig. 1 — (a) Number of Co⁶⁰ teletherapy sources installed in Canada and the United States through 1956. (b) Number of curies produced in the United States for Co⁶⁰ teletherapy machines through 1956.

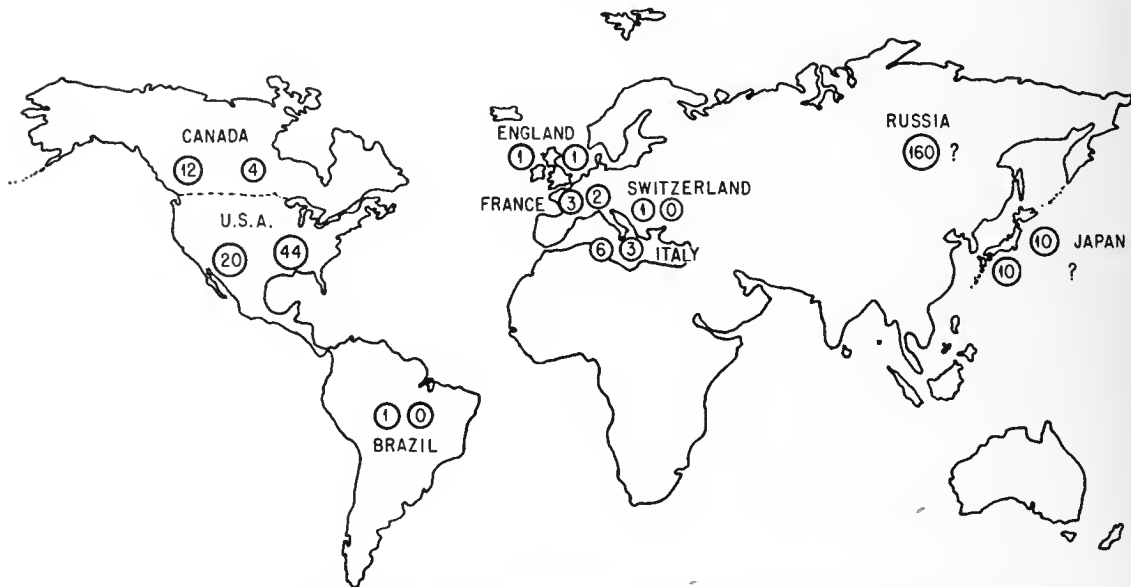

Fig. 2 — World distribution of Co⁶⁰ teletherapy machines. The circle on the left in each country contains the number of Canadian sources in operation; the circle on the right, United States sources.

Canadian Co⁶⁰ sources in operation in teletherapy machines. I know personally of more than five English, Dutch, Swedish, and Norwegian sources, but I am not sure where they were produced. Since making up this chart (Fig. 2), I have learned of a number of other machines in operation. The curriage of the source in each Japanese machine was dependent upon the availability of cobalt rather than upon what the physician wanted. These sources will eventually be enlarged. To a certain extent this is the situation as it exists in most countries.

One other circle in Fig. 2 should be examined. It is difficult to be fair in making an estimate of the machines from the U. S. S. R. At the Geneva Conference in 1955, the delegate from the U. S. S. R. indicated that there were probably between 4 and 16 machines in operation at that time. The impression was very definitely given that there would be 160 machines in operation very shortly. What the Russians mean by "very shortly" we do not know. Thus the fairest estimate is that within the next few years there will be about 160 machines in operation in Russia and its satellites.

This should be compared with about 125 machines in operation in Canada.

It is very important to make an educated guess about what will happen in the next few years. It takes a long time to produce Co⁶⁰, and the manufacturers must plan for the future. It is necessary for planning purposes to have some idea of what the saturation level of Co⁶⁰ teletherapy production will be. We have chosen 1966 as the target date for reaching this saturation level.

First, we should estimate the number of 200- to 250-kv therapy machines now in operation (Table 1). It is surprising how difficult it is to obtain this kind of data. No one knows how many deep-therapy machines there are. We have some fairly good figures for the United States. Donaldson in Ann Arbor, Mich., estimated that about 1850 deep-therapy machines were in operation in the United States.

For Europe I made a very careful calculation. I went to bed one afternoon, closed my eyes, and thought and thought until suddenly I had a vision in which it was stated that there were 2000 deep-therapy machines in operation in Europe. This is obviously a very accurate figure.

For the figures from Japan Dr. Kakehi did the same thing. He came up with the figure of approximately 1000 machines in Japan alone. I cut this figure down by including Japan and all the East. Since nobody knows what I mean by the words, "Japan and the East," this figure is a very accurate one.

To get the figures for South America, for England, and for all the other countries, we made an estimate based on population. For England we said there were 500 deep-therapy machines in operation. In Africa we could not go by the population figures alone, and so we juggled the figures to include only the extreme northern and southern portions of Africa.

The total for the entire world added to exactly 6551 deep-therapy machines in operation in July 1956.

The accuracy of this figure depends upon your level of narcosis.

We have to make some assumptions about these figures to arrive at a production estimate for Co⁶⁰. First, we must assume that all 250-kv therapy will be replaced by the new miracle, Co⁶⁰ (I have some newspaper clippings proving that Co⁶⁰ is the new miracle). However, we must also assume that not all these machines will be replaced with Co⁶⁰. We should also assume that some Co⁶⁰ sources will be used twice, and some, even more than twice.

Table 1 — BASIS FOR PREDICTION OF WORLD NEED FOR Co⁶⁰ AND Cs¹³⁷ TELETHERAPY SOURCES* (Estimated No. of Co⁶⁰ Curies Needed by 1966 is 3 to 5 Million Curies)

Estimated No. of deep-therapy X-ray machines		1956 planned goals for production by 1966, millions of curies	
Europe	2000	United States	0.5
United States	1800	United States	0.05†
Japan and East	1000	Canada	1.0
South America	600	England	0.5
England	500	Japan	0
Africa	350	Sweden	0
Canada	200	Norway	Small
Australia	100	Italy	0
New Zealand		India	0
Total	6550	South America	0
		France	?
		Total	2.05

Deficit: 1 to 3 Million Curies

* Assuming that some sources will never be replaced with Co⁶⁰, that some Co⁶⁰ sources will be used twice, and a 1000-curie (Co⁶⁰ equivalent) average per machine.
† Cs¹³⁷.

One very useful figure is that the average purchase of Co⁶⁰ for a single teletherapy machine is approximately 1000 curies.

Some other assumptions must be made that are not listed in Table 1. We must assume that the hospital population will double by 1966. This is a conservative estimate. Some organizations have estimated that it will double much sooner than 1966. We should also assume that, if the world hospital population doubles, then the amount of radiotherapy done on the patients will double. This is also a conservative estimate because of the increasing age of the population and consequent increasing incidence of cancer.

Another very important figure for which we have no estimate rests on the fact that Co⁶⁰ will be used for many things other than teletherapy. In fact, the teletherapy use of Co⁶⁰ promises to be one of the unimportant uses of the isotope. The greatest use will probably be made by chemists in various kinds of chemical-polymerization problems. Another large use will be made in the field of radiation sterilization. It is also used for seed irradiation. Seed irradiation does not sound like a very big business to medical

people, but apparently it has a far greater importance in world politics than anything medical.

If we assemble all these assumptions in Fig. 3, we can show that by 1966 between 13 million and 16 million curies of Co^{60} will have been purchased.

Also, it is becoming very obvious that there are at least two sizes of teletherapy machine. When a 2000-curie Co^{60} source decays to 1000 curies and a 1000-curie source decays to 500 curies, this Co^{60} will not be wasted. Eventually someone will establish a bro-

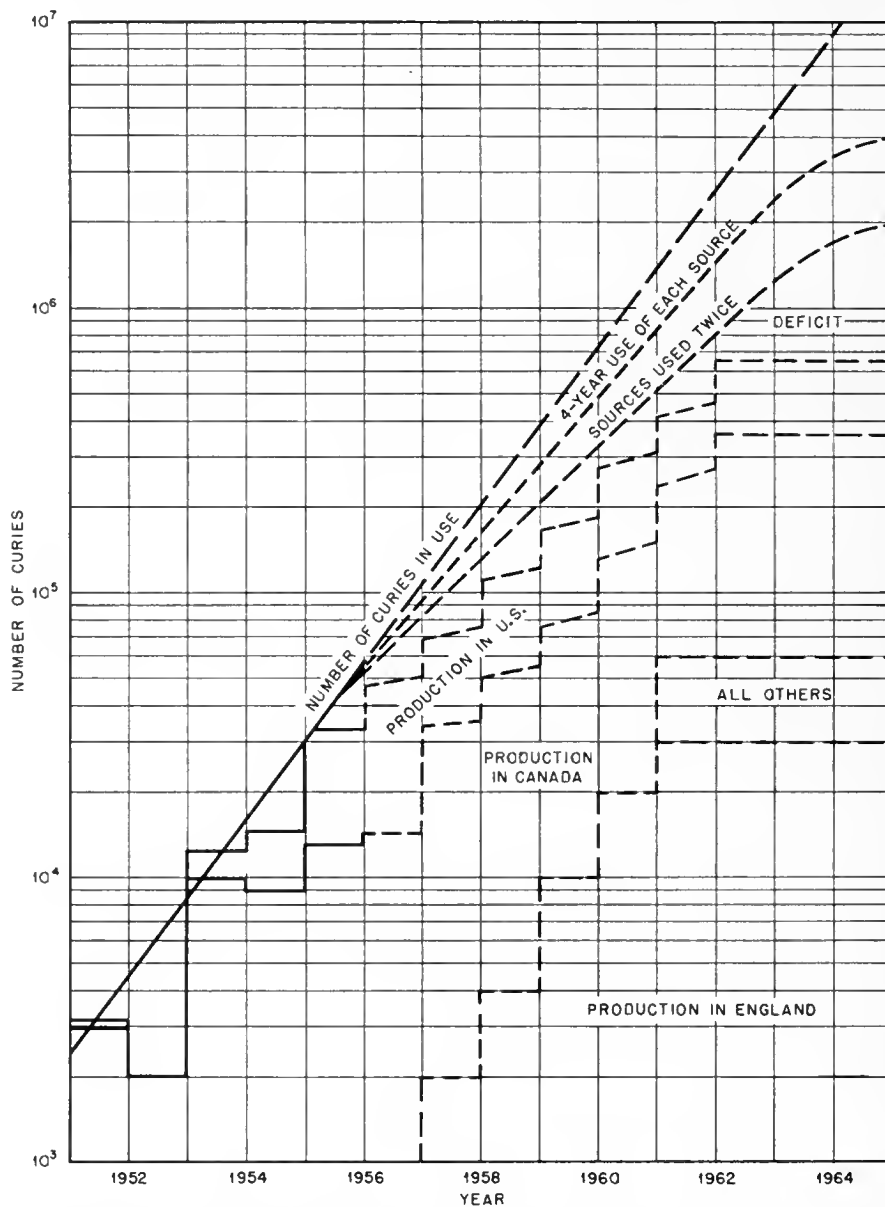

Fig. 3— Estimates of future production and the deficit (which will be 1 to 3 million curies by 1966) of Co^{60} . The U. S. S. R. is not included.

For our purposes we can assume that every one of these sources will be used for an average of about four years. Most physicians are changing their cobalt sources before a complete half life has been spent; some are changing much earlier. On the average it looks as though there will be about a four-year replacement modulus. Therefore we can decrease the original estimate of 13 to 16 million curies by a factor of $\frac{1}{4}$.

kerage system, and all these sources will be used twice or even more. In reducing the original estimate, we come to the same kind of figure that we got before. The annual use of Co^{60} will be somewhere between 2 million and 4 million curies.

If we consider the production that is currently promised in each country, we get a different kind of figure. England has stated that they may be able to produce about 30,000 curies of cobalt per year. We

believe that all the other countries — France, Norway, Holland, and Sweden—might be able to produce a reasonable amount, but they have not made any definite promises yet. Therefore I have included in Fig. 3 a promise of another 30,000 curies/year to represent these countries.

The Canadian production is promised to be about 300,000 curies/year. I am almost sure they can produce much more than they estimate. Therefore I have enlarged their prediction.

Production in the United States is shown in Fig. 3 to be 300,000 curies per year. Actually about 200,000 curies has been publicly promised, but the producers in the United States could also be pushed as we have pushed the Canadians. I have made our estimate a little fatter than it should be. In Fig. 3, I am assuming a relatively uniform increase for the next few years, but it is likely that the production figures will exceed my padded predictions.

At the peak of production it appears that we shall be making close to 1 million curies of Co^{60} per year. My estimate of the need for Co^{60} production is somewhere between 2 million and 4 million curies/year. This would indicate that there will be an ever-increasing deficit of Co^{60} . At the present we have a little more Co^{60} than can be used because the present demand is tempered by the fact that none of the salesmen are making definite promises about delivery. Salesmen have been held back and have not felt free to sell machines. A teletherapy salesman for the past few years has always been stifled by the question, "Can I get a source or can't I get a source?" I think this is the reason why we now have sufficient Co^{60} to meet our immediate needs. My prediction is that this will not be true in the next few years. If Co^{60} teletherapy continues to expand as it has in the past, there will be a great deficit in Co^{60} production. However, producers can change their estimates to meet the demand within about a two-year period. The present reactors cannot meet all the demands that might be made of them. The production of Co^{60} uses up neutrons, and neutrons are very expensive. Therefore we should be thinking in terms of other sources.

Co^{60} , as many therapists are now learning, is actually a short-lived isotope. Five years is not long in the history of a teletherapy machine. Since Co^{60} is not necessarily the most economical source for teletherapy, we should be thinking of other sources. One of these is Cs^{137} . In Fig. 4, I have shown two machines, one in the United States and one in England, constructed to use Cs^{137} .

Cs^{137} can be used in teletherapy very effectively. It has only minor differences from Co^{60} , and it has one major advantage in that there is a large amount of cesium available. Every time a new power reactor is put up in England, another few hundred tons of cesium will be produced. Every time the United States puts up a research reactor, a power reactor, or a demonstration reactor, another source of cesium is achieved. We shall be producing a sufficient amount of cesium that the problem will not be how much Cs^{137} , but what can be done with Cs^{137} .

Making Cs^{137} is simpler than producing Co^{60} . It merely requires separating Cs^{137} from a soup of many other elements and fabricating the material into a teletherapy source. This has already been done in the United States. It has already been accomplished

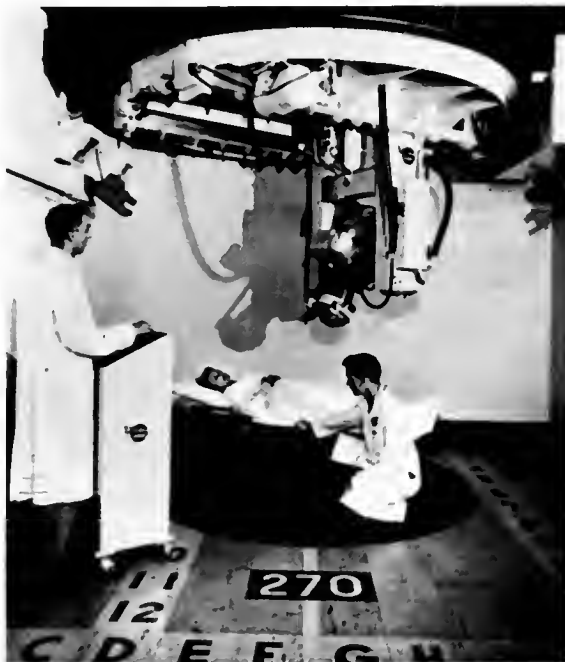

(a)

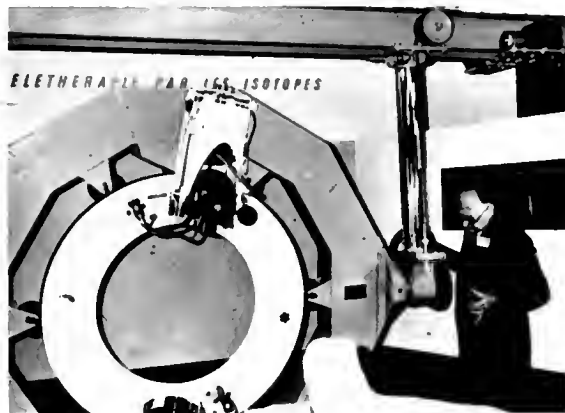

(b)

Fig. 4—Two Cs^{137} teletherapy machines. (a) Oak Ridge, Tenn. (b) Southampton, England.

in England. Though production of Cs^{137} for teletherapy will certainly be a headache for chemical engineers, it is no longer a difficult job; it is merely a tedious one.

Many other ideas have been originated which can be developed. Figure 5 is a picture of the machine produced on our Westinghouse contract. The primary specification in the design of this Westinghouse machine was the economical use of Co^{60} . In accomplishing

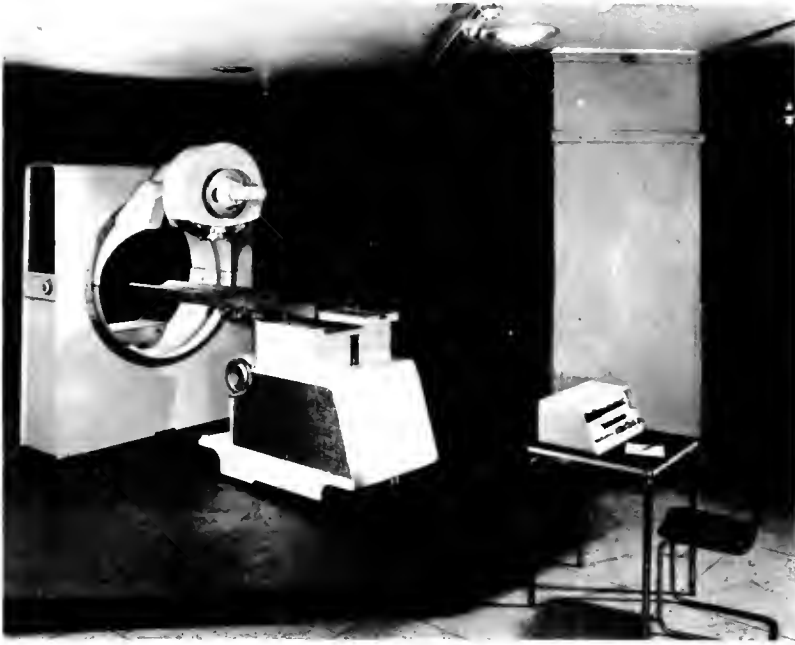

Fig. 5 — The new Westinghouse Co⁶⁰ teletherapy machine.



Fig. 6 — Models of experimental teletherapy machines emphasizing low energy, short life, or special purpose.

this design, we were thinking not so much of the source as of the design of the machine for its most efficient use.

Figure 6 shows some of the other things which are being thought of and which eventually will be accomplished. With all the therapists in the world thinking in terms of supervoltage, it is now time to muddy the waters a little by going back to low-energy sources.

The people at Harwell, and particularly at Cambridge, have proved that it is possible to use a short-lived source for teletherapy. The Keleket people especially have proved that it is not only possible but feasible to transport shipping containers even with very high energy sources. It has already been demonstrated that there is no danger in the problem of replacing sources and that it is not an expensive procedure.

Therefore we can again consider short-lived sources and low-energy sources, and we should be reexamining the whole problem of sources for teletherapy. The requirements put on isotopes for teletherapy in 1950 are no longer reasonable.

In the past we have been thinking of single-source machines; copying the old X-ray machine need not

confine our thinking to general-purpose devices since it is probable that radiotherapy indications will increase rather than decrease. Therefore we must think in terms of machines built for special purposes. These special-purpose machines may make radiotherapy more efficient and more desirable in the future.

Many designs of teletherapy machines have now been published. One new type machine we are working on is very small. It will use a very low energy source, probably Eu^{155} or even samarium. It can be designed as a cavity irradiator. Such a machine would have a very limited use, but it was designed for this.

Another kind of source that should be considered is the multiple source that I first heard of from "Tiger" Ellis at Oxford. Dr. Newell at Stanford has also been talking about the multiple-source idea; and Dr. Hummon has been thinking in terms of extended sources.

We no longer have to think in terms of small pellets that approach a point source. As soon as we dismiss the idea that Co^{60} is the only source of radiation available for teletherapy, we can expand our horizon into the fields of multiple sources, extended sources, low-energy sources, and short-lived sources.

DISCUSSION

CHAPTER 25

Kelly: When Dr. Brucer asked me to discuss source production, I asked him where I might obtain some information on it. He informed me that no one else knew anything about it and that I could say anything I liked.

Future source production is apparently determined by a changing neutron-flux and neutron-volume picture. It appears that we shall eventually have sources of very high specific activity. This must lead to changes in dosimetry, control, delivery time, and even our ideas of protection. We may be reverting to smaller sources; we may even be approaching the so-called "point source."

Something that should interest all of us is the comment that the medical use of large sources may be only a comparatively small percentage of the source-production problem. We medical people are in procurement competition with richer and more powerful industrial organizations.

Isherwood: I have attended many of these meetings, including the original one, but as yet I do not have supervoltage of any type. Very early we attended committee meetings and heard ideas pulled out of the air. Many of us, I am sure, felt that these were merely hypothetical situations that would never come to pass and that they were quite impractical. And yet they have come to pass; as I watch the cesium machine develop in Oak Ridge, I am certain there is a good deal of truth in what Dr. Brucer says in his estimates at the present time.

An interesting problem is the reuse of cobalt and the idea that eventually there will be some type of brokerage establishment to take care of this and to resell it. I do not have many years until I retire, and so this might be a good game for me to get into. There should be no difficulty in selling all small sources. I wonder if there will be many multiple small machines because of the economic problem involved.

I would like to ask this question, although I do not suppose anyone has the answer: When we start producing cobalt in large quantity, how are we going to

regulate its use or sale? Will there be a world-wide distribution, or are we going to be selfish and limit the production in this country to our own needs? Then will the other countries do the same thing, and will this be a general distribution? Will it be first come, first served? Or will the one with the money get it?

Freid: I became apprehensive as I listened to Dr. Brucer and heard the proposed number of machines to be produced and sold—apprehensive because some of these machines will fall into the hands of radiotherapists who are poorly trained for conventional radiotherapy and who have had no training with supervoltage irradiation.

This is a serious problem. I know of a radiologist in the vicinity of New York City whom I regard as poorly trained and who is contemplating the installation of a Co^{60} teletherapy unit.

I believe there should be some regulation of the sale of the Co^{60} source to prevent these units from being used by poorly trained radiotherapists. I also believe this supervision should be at a high level, perhaps by the Atomic Energy Commission.

Tice: This problem has been demonstrated to us very forcefully within 200 miles of Kansas City; Co^{60} units have been installed in one town in Kansas and in one town in Missouri. The man operating one of these units finished his residency the year the unit was installed, and he is in charge of it. I trained the man who is in charge of the other unit. I think he is well trained in conventional radiotherapy, but he does not know anything about supervoltage because I do not know anything about it.

Our problem is to see that such men attend meetings like this. All of them, though capable persons, need to learn about the new procedures.

Brucer: Let me present my views on the question of government regulation or supervision now because it is very important. Government regulation is always, without exception, a more tyrannical regulation than that of the individual regulating himself by the dictates

of his own conscience. For a long time, even longer than the existence of the United States, the medical profession has maintained the position that it can regulate itself by its own conscience. When one asks for government regulation, one gets government regulation, and one spends more years acquiring relief from the government regulation than one spends obtaining it. It is much more important that physicians get together and regulate themselves. When this is done, there is no need to ask for, or even to accept, government regulation.

Carroll: I certainly would like to endorse the views of Dr. Brucer concerning government supervision. It is very important that we attempt to establish our own controls over the use of this equipment without resorting to governmental regulation.

I would like to ask Dr. Brucer a question about production. It is my understanding that a great many more nuclear reactors are being contemplated for power production etc. It seems to me that in these reactors most likely there would be hot spots, places where neutron flux is exceedingly high and where it is necessary to reduce neutron flux.

Would it be economically possible and feasible to use cobalt for reducing flux in those hot spots, and could not these machines, therefore, be used for a dual purpose?

Brucer: Rather than my answering that question, let us ask an expert on the subject, Mr. Beauchamp.

Beauchamp: I am not a physicist, nor am I an expert on power reactors. From the preliminary designs and thinking on power reactors, I doubt very seriously that they have considered putting things in like cobalt.

Another thing, in thinking about power reactors, is that I am not sure that our people would be interested in putting things in a reactor that may have to be taken out at any time other than at regular shutdown periods.

I have a question for Dr. Brucer. Since he evidently has a contract to study better machines and better ways of using isotopes from a production standpoint, I wonder if it is not appropriate at some time to bring in a professional market-survey organization to give us their best guess.

Brucer: The only organization I know of that could consider the kind of regulation we want, unless it is Union Carbide Nuclear Company, is the Radiological Society; we have an expert on this, too—Dr. Scott.

Scott: I can see the value of having an economic survey made. We have been discussing having an opinion survey made by the American College of Radiology, and I think such a thing could probably be included. All the manufacturers, such as Westinghouse and General Electric, have their own methods of surveying the market to determine what their production should be. But I do not know how secret that information is.

Nevertheless, it could be done. I think it is probably important enough that we do undertake such a program.

I would also like to second everything that Dr. Brucer said about government control of the medical profes-

sion. I think our responsibility lies in training the young men, to see that they do know something about supervoltage irradiation before they finish training. If such training is not available, there should be some way of interchanging them with places where training is offered.

Our scientific organizations, the American Roentgen Ray Society and the Radiological Society of North America, will undoubtedly conduct refresher courses on this subject.

As interest grows, we must remember that this field of science is actually just an infant in years. None of us dreamed, even two years ago, that we were going to be in a position such as this. We must catch up with it, so to speak; the American Board of Radiology, which certifies radiologists, knowing that equipment is now economically available and that it can be operated on a reasonably satisfactory economical basis, will have to give the applicants a more extensive examination on supervoltage radiation.

I have been asked a question on the economics of supervoltage. The economics must be evaluated very carefully because, in private practice, we cannot subsidize our therapy section heavily. We can subsidize to a certain extent, but we do not want to become involved in anything that will not pay its own way.

Patients will not beat a path to your door just because you install a cobalt unit, and the doctors in the neighborhood will not refer patients to you for treatment because you have a cobalt machine.

I am sure this is the experience of most people who have installed supervoltage machines. One must first do a good job to earn a favorable reputation in the community and to gain the confidence of the referring physicians. Therefore the cost analysis must be made considering what one's own practice can support.

As I mentioned before, we were in a favorable position by moving into a new office building, and thus our protective barriers and our costs were kept to a minimum. I do not believe that we could have added a new room to our old office for a cobalt unit and have it paid for by the fees from patients.

I can tell you how we operate. We take care of any patient who comes to the door; it makes no difference whether he has a dime or whether he has a hundred thousand dollars. We never send a patient to the clinic and say, "You are a clinic patient; go over there and get free treatment." If they come to our door, they receive the help they need.

We also take care of the families of physicians and physicians themselves who choose to come to us, without charge. One must take these factors into account when computing charges. On our present scale we are charging between \$8 and \$12 a treatment. If we can average somewhere between these figures, we think we can break even. We are not going to make any money on it.

We have to compete with the hospitals in our community. The greatest competitor we have is the University of which I am a member. They have a betatron for which they charge \$15 a treatment, but still it has to be subsidized.

The clinic patients are treated with the betatron, and the Medical Department stands this expense. However, the clinic offers opportunities for research, which is always a heavy expense.

Simon: We are essentially in the same position as Dr. Scott in that we, too, treat anyone who comes in; we charge several different fees, depending on whether the patient is a semiprivate, private, or clinic patient.

We differ from Dr. Scott in one respect: We are essentially a radiotherapy office, and therefore we acquire our livelihood on the basis of practice. We are volunteers at the hospital, and therefore we must make this operation profitable.

Freid: About 4 years ago at the time of installation of our kilocurie unit, Montefiore Hospital calculated the approximate cost per treatment. The computation was based on the number of daily treatments and included the cost of the equipment, space occupied, salaries of physicists and technicians, insurance, telephones, lighting, etc. The cost per treatment was about \$12. This figure allowed for 50 per cent of the patients to be treated gratis. These figures are very close to those Dr. Scott calculated.

Brucer: I should like to discuss now the use of uranium as a source head.

When the discussions on an International Source capsule for Co^{60} were first begun, many of the manufacturers expressed the idea of using uranium for a very small source capsule. Uranium would yield some advantages. Therefore we obtained permission from the AEC to consider the use of uranium, and it was stated that they would allow a reasonable amount of uranium to be used for the manufacture of small pieces of a teletherapy machine.

However, after the manufacturers had received the information on what happens in machining uranium, on the price of uranium, and on the disadvantages that accompany its use, they decided to continue using tungsten alloy.

One should always remember that there is something even better than uranium. A few hundred miles to the north of Oak Ridge are a few tons of gold buried in the ground doing absolutely nothing. Gold would be an excellent material to use in teletherapy. It would be even better than uranium. If we are going to talk about impossibilities, why not talk about the use of gold. One could design a solid-gold teletherapy machine. In this way a radiologist could store his life savings in one teletherapy machine. Uranium, however, is not like gold. It is not a useless material. Uranium is a very valuable fuel element. I think the best answer concerning the use of uranium can come from the one man who has a uranium teletherapy machine, Dr. Carpender.

Carpender: Most of you heard the description of the unit. The uranium is on loan to the Argonne Cancer Research Hospital from the AEC; it does not belong to us. They can reclaim it at any time. As a matter of fact, several times they have threatened to do this, but they have told us that, if they did, they would replace

it with suitable material, either uranium not of use to them or some other material.

I think Dr. Brucer's suggestion of gold is a very good one, and it seems to me really to be more feasible than uranium because, as he says, uranium is extremely difficult to fabricate. It makes excellent flints for cigarette lighters; the sparking is beautiful. It must be cast in a vacuum furnace. As a matter of fact, our housing was so large that the Argonne National Laboratory was unable to handle it in one piece and had to do it about three times to get a satisfactory housing.

We are not the first to use uranium for housing of teletherapy units. I believe that Great Britain was considerably ahead of us on this. Dr. Roberts can perhaps verify this statement. It is an extremely satisfactory material, however. I discussed the use of uranium with Paul Aebersold, and he indicated that, if any of the manufacturers were willing to undertake the fabrication, it might be possible to obtain release of depleted fuel.

I have the impression that the advantages of a material such as uranium or gold were not thoroughly understood by the "powers-that-be" who could give permission to release it; they were not aware of the advantages of the small size and the clearance that you would get by using uranium collimators.

May I say something about Dr. Freid's comments concerning the use of this type of equipment by the uninitiated? As many of you know, the American Board of Radiology this June for the first time gave examinations for the use of radioactive isotopes. In 1960, to obtain a certificate in radiology, the examination in radioisotopes will be required; it is now optional.

It is apparent that facilities in the United States for training in the use of radioactive isotopes are not adequate. The smaller institutions will turn out men who cannot meet the requirements of the Board at the present time. Therefore some shopping around and some interchange of people in training will be necessary.

I think the same thing will apply to supervoltage, but this raises another question. This question I cannot answer, and I do not know who can. The required period of training is three years; if one is to achieve a certificate in radiology, which will indicate proficiency or at least basic knowledge in diagnostic radiology, in conventional routine radiation therapy, in the use of radioactive isotopes in nearly all the forms, and in supervoltage, I just do not know how this can be done in only three years or even in four years of training.

Cooper: I wish to ask Mr. Gillette a question concerning the stack source. Would it be possible or practical from time to time to replace the wafer of the lowest curiage with one of high curiage to maintain the total?

Gillette: This is a possibility.

Cooper: Would it be economically feasible?

Gillette: Perhaps. The problem would depend on the particular source. If the source happened to be loaded

with some low-specific-activity material in the rear, i.e., away from the window, perhaps that material could be replaced.

Loevinger: I should like to ask a question of Mr. Gillette along somewhat the same line. Why cannot Oak Ridge follow the practice of our enlightened northern neighbor in two things: first, sell sources on the basis of roentgen output and, second, accept sources for return or reactivation or otherwise help with the problem of the economical disposal of decayed sources?

Benner: I have a question concerning the new source capsule about which Mr. Gillette was speaking. Will it fit into machines made for the International Standard capsule? There has been much discussion of the short-coming of the teletherapy source because of its large size. How soon will it be possible to get the 1000-curie source in the 1-cm-diameter wafer comparable to the Canadian source, which I think is 1 cm?

Tice: I should like to elaborate on the question asked about replacement of the source. Suppose I have 500 curies now and five years from now I want to dispose of it. I am faced with either selling it or putting it into another machine. I do not have time to sell it, and I do not have another machine.

Suppose I just kept it, say, for 25 years; by that time I believe it would be down to 10 or 15 curies. Would there not be some danger that someone would shove it in the back closet at that time because it is not worth much? Would it be a health hazard there? It seems to me that in years to come it will be a rather big job to keep track of all these sources that rove from one person to another over the country.

Gillette: A number of questions have been asked which I shall try to answer. First, on the reactivation, we realize that the Canadians have said they would accept sources for reactivation. Cam Hetherington probably can give information about whether they have tried it.

In the reactors available to us there are problems prohibiting this. In the first place, these reactors are not under our own supervision. The material is being irradiated in the Materials Testing Reactor, Idaho Falls, Idaho, the reactors at Hanford, Wash., and the reactors at Savannah River, S. C. These reactors were not built for the production of radioisotopes, particularly not for cobalt; they are for an entirely different purpose, and it is not economically feasible to try to reinsert hot material into them. The economics would be just terrible.

As far as the disposal of cobalt is concerned, the AEC has records of everyone who obtains radioactive material, and I suppose they will keep in touch with everyone who has been licensed and who has received material. Therefore there should be no possibility, at least at the present time, of anyone's forgetting that he has cobalt.

If a person wants to dispose of the cobalt and if he has no other means of doing so, we have a standard

service at ORNL for the disposal of waste at a nominal fee, \$10 per container disposed of, provided it does not weigh more than 400 or 500 lb and is shipped to us in a container that can be dumped into a burial trench.

Cooper: Would you mind amplifying the answer you gave me on whether or not it would be feasible to extract the wafer of lowest curiage from time to time and replace it with one of high curiage?

Gillette: Yes, I think this can be done. We have not done it as yet, but in our loading facility, at least in the current capsule or the one we anticipate making, one should be able to open the capsule, remove the cobalt, and insert new cobalt.

Benner: The new capsule would fit into machines designed for standard capsules?

Gillette: Yes, I think it will. The outer dimensions of the capsule we are thinking of would be something on the order of the dimensions of the interior of the International Standard capsule.

Loevinger: Why do you not sell sources on the basis of the roentgen output?

Gillette: Here again, we are set up just a little differently from the Canadians. The Canadians produce teletherapy machines; we do not. We produce only cobalt. Any apparatus that we would set up for readings would result in readings that would be different from those obtained by a person using his own equipment.

The simplest method is to use whatever experience is available in determining output based on the specific activity of the material to be used; thus we shall continue to sell on a curie basis.

Hunt: The other question, Mr. Gillette, was: How soon can we anticipate getting 1000-curie sources in 1-cm-diameter wafers?

Gillette: I do not know. The Canadians are talking about 100 curie/g material, and it can certainly be done with that. The material that we are now producing ranges between 40 and 50 curies/g in specific activity.

Hunt: How high can you go with one single source within the 1-cm diameter at present curiage?

Gillette: A source 3 cm long but 1 cm in diameter could be built. This would give about 20 g of cobalt, and at 50 curies/g this would give 1000 curies, less the loss in efficiency or absorption.

Hunt: Would that fit into a standard capsule?

Gillette: It could fit a standard capsule if a spacer were used around it so that it would be centered in the capsule.

Beauchamp: John, expand on uranium shipping containers. Are they used only for Project irradiations?

Gillette: That is correct. At the present time we do have uranium shipping containers, but we use them only for other AEC installations; how long it will be before we can ship them indiscriminately in this

country, I do not know. We should like to use them because they mean a great saving to the customer in transportation charge.

Loevinger: Is uranium valuable these days? What does the grade used for containers cost per pound?

Gillette: I cannot give you a figure on that. It would vary from person to person, depending on what kind of emphasis you want to put on the material.

Scott: What might be the expected price range of cesium?

Gillette: At the present time cesium sells for \$100 for the first curie, \$25 thereafter for each curie up to 500 curies, and \$10 per curie thereafter. This averages to a price of around \$13 or \$14 a curie for a source of about 1000 or 1500 curies. Once we get some cost data on the new pilot plant that we are building, it will be possible to reduce the price of cesium substantially—probably bring it down in the range of \$5 a curie. It may not happen at once but rather over a period of time.

Loevinger: Is there a supply of uranium depleted in U^{235} ? Can it be available for shielding purposes without objection from anyone?

Gillette: I think you will have to consult the AEC.

Ter-Pogossian: I am wondering if Dr. Brucer is not a little pessimistic about the cobalt deficit. He has discussed teletherapy sources and not particularly isotope teletherapy sources. A certain number of accelerators can be used to take care of these needs. At present there are a number of accelerators, such as betatrons, linear accelerators, Van de Graaffs, and resonant transformers. These instruments, although somewhat more costly, are in certain respects more efficient than cobalt. They have small focal spots, and their output is considerably larger.

As a matter of fact, if I am not mistaken, in England it is considered that, roentgen per roentgen, accelerators are cheaper than cobalt; consequently I am wondering if efficient accelerators would not take care of part of that deficit.

Smithers: I did say that this question of cost in terms of so many roentgens at a depth was well worth considering, and I do think it puts the linear accelerators in a very favorable light indeed.

While I am here, may I say that we have a cesium unit with a part-uranium head. It is not yet filled; it still has no cesium in it, but this is a minor detail.

May I say one other somewhat more serious thing about this whole problem of telecurie apparatus? It seems to me that the iridium apparatus in Cambridge is an extremely good replacement for radium applicators. For the sort of difficult job around the pinna of the ear or corner of the cheek, for example, where radium applicators are not useful, this is a fine replacement.

In the next range, the teleradium range, I do not think we have yet seen a better replacement than

radium itself, although small cesium units may well become so.

For the next step, the larger cesium unit will surely be a very good replacement and will do a far better job than most of the 200-kv apparatus we have had in the past; it may put 200 kv nearly out of business, if not quite.

For greater irradiation, i.e., with the cobalt units on the teletherapy side, I do not know yet whether there is a replacement for that at all. Europium has been talked about a great deal, but apparently there are many difficulties; it does not seem to be coming off, and in this range at the moment cobalt stands alone. Its greatest competitors are, as has just been said, the linear accelerators.

I am not very happy about the statements concerning the number of deep-therapy apparatus in use all over the world and their wholesale replacement by super-voltage. There are many other factors that have not been discussed, probably the chief of which is building—providing the places to put them—which seems to me a real long-term difficulty.

Just for interest let us consider this wonderful dream figure of 500 deep-therapy apparatus in Britain. I have been trying to determine if it is anywhere near the mark and am working hard at it. The only way I can get at an estimate is that I do know how many deep-therapy apparatus there are in the two southern metropolitan regions of England; the number is somewhere between 60 and 70. This is for a population of 8 million, and, when I start multiplying, it looks as though this dream is jolly nearly right.

Roberts: I was not quite sure whether we have a fully uranium-protected unit in Britain. We have a number of smaller units in which there is partial use of uranium, and this does raise a simple physical point of the economics of telecurie-unit head protection. A great deal can be said for putting a comparatively small quantity of uranium around the source. By doing this, one saves large quantities of lead and reduces the diameter of the whole head. This is being done in a number of British units and designs.

We have a number of small cobalt telecurie units, which were not included in Dr. Brucer's tables, in which something of this kind has been done for the purpose of economy, and in quite a number of places we have made use of uranium for diaphragms, nozzles, etc. This seems to be a very useful and economical method of using uranium.

About the status of the uranium supply in Britain, each year Harwell will allocate a certain amount of uranium—I think it is 1000 lb/year—for purposes of that kind, for making up medical apparatus. It is not sold, but loaned, to users, and Harwell insists on doing the major machining and fabricating of the uranium. It is loaned at fairly nominal rates, and the arrangement seems very satisfactory.

While I am here, may I ask Dr. Brucer just one or two not facetious, but near-facetious, questions? In one of his estimates, about which I am most unhappy in spite of Dr. Smithers's confirmation of the figures for

Britain, one of his assumptions was that the hospital population would double or treble in the next 10 years. In addition to the buildings, I am concerned about where we shall obtain the radiotherapists and even the "cheap" physicists to maintain such an increase in patient population in the radiotherapy department.

In regard to the estimate for the British cobalt production of 30,000 curies/year, I wondered if that was a recent estimate, made since the design and setting up of the new heavy-water reactor or reactors at Harwell, which I believe will contribute largely to isotope production.

There is a third major question, a point that Dr. Brucer seemed to avoid and about which I was rather surprised. In a conversation before this seminar he had quite a lot to say about cesium production, but he has apparently dodged it completely in this seminar. I wonder if this was quite deliberate.

Brucer: Let me answer those three questions while I still remember them.

About the cesium question it should be remembered that I set up a committee for the organization of this seminar. One of the requirements the committee imposed on this meeting was that I should not be allowed to sell cesium.

The second question concerned the figures for the hospital population. I do not remember exactly where I got these, but I have been reading a magazine called, I think, "Hospital Administration," which had estimates on the requirements for future hospital buildings. Many of the hospital administrators have pointed out that there will be a need for more hospital buildings. I think it is very obvious that, with the need for more hospital buildings, there will also be a need for more hospital personnel to staff these buildings. Where we are going to get the "inexpensive" physicists and the "expensive" radiotherapists is a big problem. All I have been trying to do is to point out the same thing that many other people are pointing out: if the population of the world is going to increase very rapidly, and it appears that it is, then the population of professional people cannot stay constant, and the availability of machines and sources and all the other equipment necessary to furnish services to this population will have to increase. The population of trained personnel, as Dr. Carpender pointed out, appears to be entering a period of serious shortage. This is something that we must be thinking of continuously. It is about time that we stopped thinking about the problem and did something about it.

Concerning Co^{60} production in England, my latest figures on the subject I acquired from Mr. Errington,

who had just talked to some of the Harwell personnel. I blame that figure on AECL; but no one should expect these figures to be accurate. We are all making the best guesses we can about what might be done.

Hetherington: Since Dr. Brucer stated that perhaps the medical use of cobalt may not be the largest one in the long run, I should like to mention that we have supplied some low-specific-activity cobalt for industrial use. We are making it up in small building blocks, small cobalt rods 1 in. in height and $\frac{1}{4}$ in. in diameter. These are aluminum clad and irradiated in the low-flux positions of the reactor; thus in about one year's time they will become about 1 curie/g. We now have on order about 160,000 curies of this material for pilot-plant stages of various industries, and we have discussed with one or two customers megacurie quantities of this cobalt, which, of course, is not immediately available.

Friedman: This seems an appropriate time to discuss not Dr. Brucer's paper, but Dr. Brucer. I know he would prefer to leave the room, but I shall ask him to stay.

Dr. Brucer is a good executive. An executive appoints a committee to do the work for him, and he supervises it. Dr. Brucer appointed a committee to organize this meeting and then proceeded to do almost all the work himself in a fashion superior to that which the committee could have accomplished.

We here today owe him an enormous debt in being permitted to participate in one of the truly exciting radiotherapeutic conferences. People other than those in this group owe Dr. Brucer a great deal for the advances in design, development, and popularization of telecurietherapy apparatus.

Other countries have their own Dr. Brucers—some of them are here today—who are also sponsoring the design and the development of new telecurietherapy apparatus, but Dr. Brucer's influence has extended beyond our country.

We have far to go in improving the design of these apparatus. I still think that we do not have a satisfactory superevoltage apparatus; neither does Dr. Brucer. As a matter of fact, he was the first one to state so. In the beginning of his agitation for these apparatus, the likelihood of a feasible one seemed small, but now, with his having excited the interest of various engineers and manufacturers, the likelihood of producing first-class superevoltage apparatus seems to be an excellent one.

I think we here today owe Dr. Brucer a great debt, and I should like to suggest that we give him a rising vote of thanks.



PRINCIPLES

PART

**OF CLINICAL SUPERVOLTAGE
IRRADIATION**

3

**Section
F**

Moving-field Therapy

Herbert D. Kerman
(presiding)

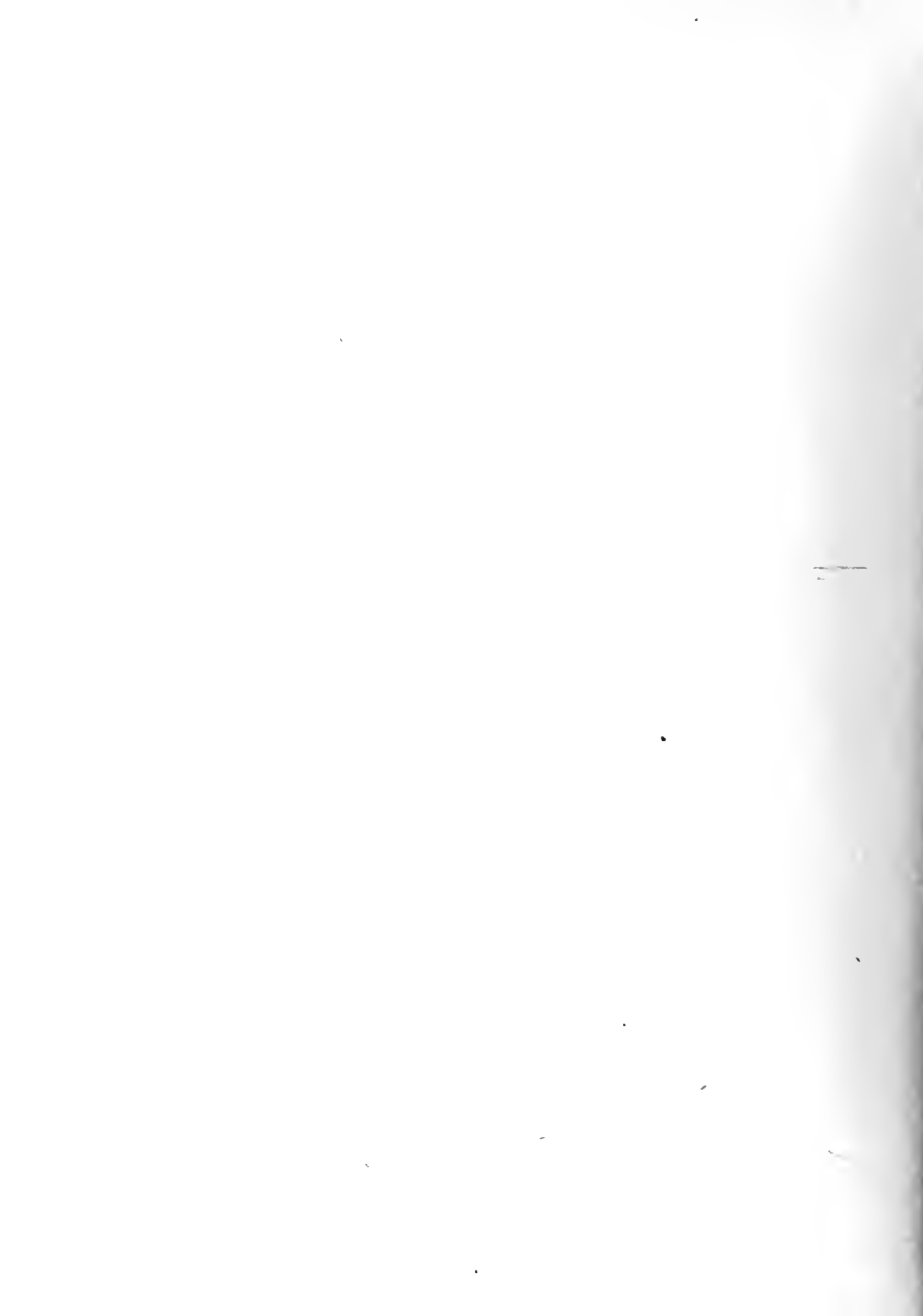

Indications for Moving-field Therapy

CHAPTER 26

J. W. J. Carpender

University of Chicago
Chicago, Illinois

My presentation this afternoon consists of two separate items. One is the subject listed in the program, and the other, which I shall cover first, is a description of the radiocobalt therapy unit of the Argonne Cancer Research Hospital of the University of Chicago. This unit was not produced commercially; it was designed and constructed by us.

John Rose should be credited with the original idea of the unit, and the design was by Lester Skaggs, Lawrence Lanzl, and Don Davison, according to medical specifications supplied by David Lochman and me. Casting of the head and the various collimators was done in the shops of the Argonne National Laboratories. With the exception of the two large supporting rings, all remaining structures were fabricated at the Argonne Cancer Research Hospital shops.

Early in 1947, Rose suggested that it would be desirable and feasible to construct a teletherapy unit for Co^{60} using uranium for the protective housing. He agreed to supply the uranium and arrange for its fabrication, provided we would undertake the rest.

When it became evident that the Argonne Hospital would be built at its present site, we discussed our plans with the Atomic Energy Commission and obtained the Director's approval for an experimental machine. High priority was given for pile time and location for source production.

Figure 1 is a scale drawing of the housing of the radiocobalt unit. Note that the source, which is contained in an aluminum capsule on the end of a uranium rod, remains in a fixed position. For loading purposes a device is backed up against the housing, and the rod is shoved through to place the source in its position. A thin aluminum disk in front of the source would prevent it from falling out if it ever did become detached. The shutter is a disk of uranium with a conical hole milled through it. It is closed by 90-deg rotation by means of two springs. We do not use a slipping clutch in this device.

There are fixed collimators and a variable collimator made of uranium. Changing collimators is

not too easy; we are using the fixed collimators less and less as we gain experience with the variable one.

Figure 2 shows the unit under construction and shows the aforementioned supporting rings that had to be fabricated elsewhere. The unit rests on sets of rollers and has side rollers to keep it from walking sideways. The drive is a $\frac{1}{8}$ -hp motor.

Figure 3 shows the unit in its completed form, with the control for positioning located at the right. There is no mechanism for turning the unit on at this point. On the opposite side is the sector clock, a mechanism with pointers and degree indicators, which allows one to set the unit to operate backward and forward over a chosen sector.

The machine will rotate through 360 deg in either direction at a rate of four revolutions per minute. The table top slides longitudinally and sideways; it can be raised and lowered and can also be made to rotate about an axis perpendicular to the floor.

The head can be angled outward 45 deg away from the primary barrier. We have found in practice, over a two-year period, that we have not used the angulation of the head outward, and we have not used the rotation of the table around the perpendicular axis.

Figure 4 shows the source in relation to an ordinary cigarette, not a king size. It is 3 cm long and 7.5 mm in diameter. The present source was installed about a year ago, at which time it was 105 curies/g. It is admittedly wasteful of radiation because the length of the source gives a considerable degree of self-absorption. We felt that this was justified in an experimental unit of this sort, and with this source (when it was placed at our source-axis distance of 81.6 cm) we got 21 r/min.

Figure 5 shows the very small penumbra with this unit. This is a 10- by 10-cm portal. It is not the usual form of isodose curve, but it is shown just for the size of the penumbra.

Figure 6 shows a patient being escorted to the treatment table.

Figure 7 shows the head, starting in a horizontal position, rotated through a small fraction of the circle

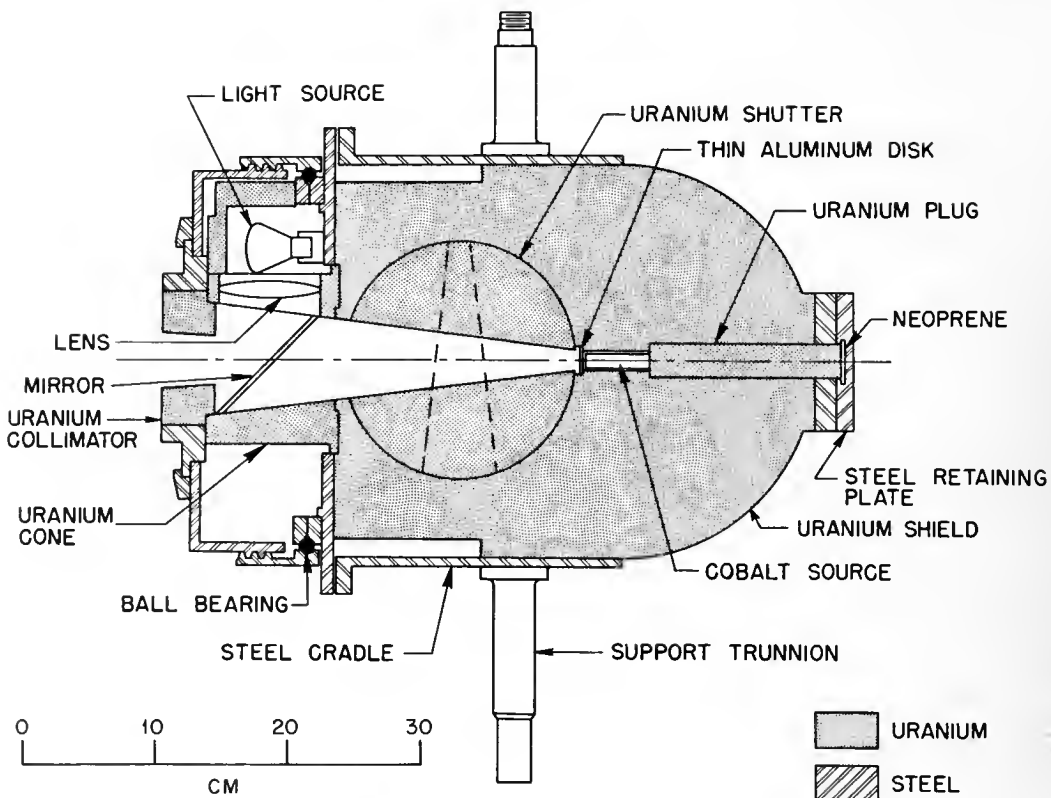

Fig. 1—Kilocurie revolving Co^{60} unit for radiation therapy, showing some construction details of the uranium housing with a fixed collimator in place. Broken lines show the closed position of the shutter.

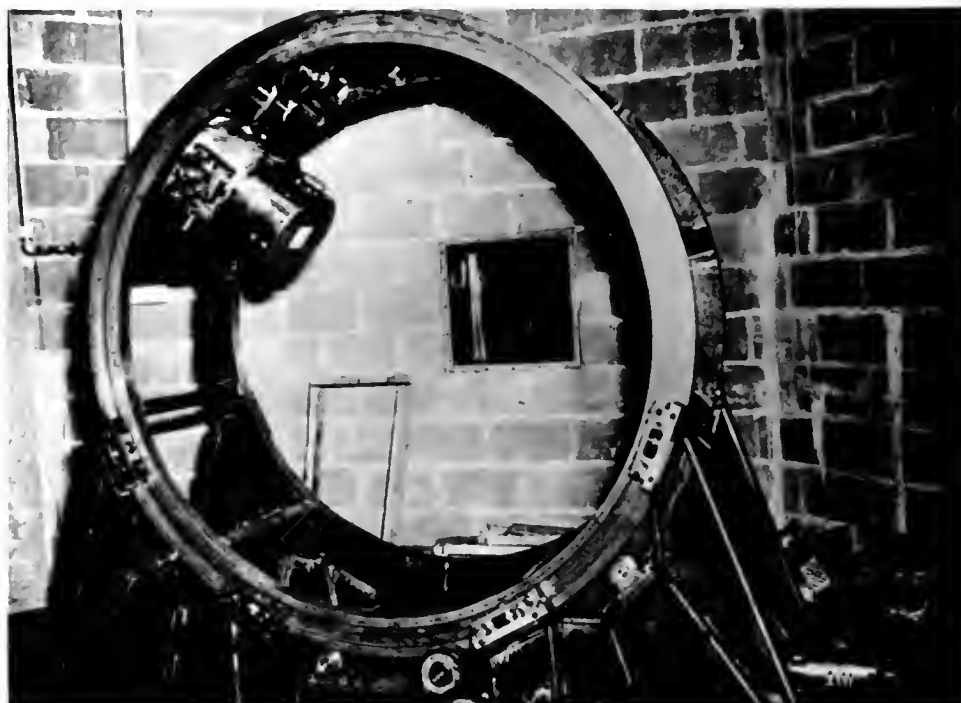

Fig. 2—Unit under construction, showing the supporting and guide rollers.



Fig. 3—Completed unit. Panel for set-up operation is at right.

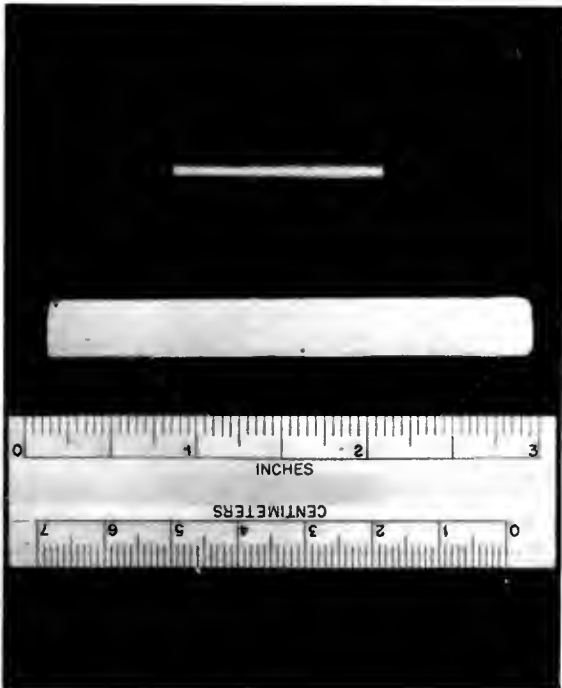

Fig. 4—Cobalt source 7.5 mm by 3 cm is shown with an ordinary cigarette and a ruler.

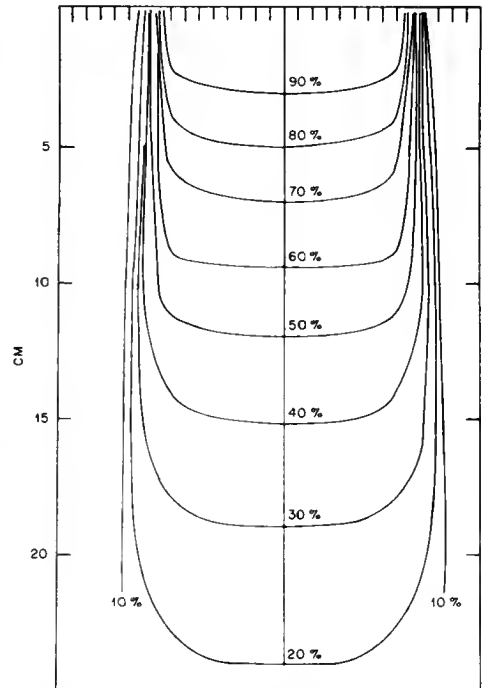

Fig. 5—Co⁶⁰ 10 × 10 isodose pattern at 71.6 cm source-to-skin distance.

(Fig. 8), and finally moved around to the position shown in Fig. 9, thus illustrating continuous rotation. A housing on the variable collimator contains micro-switches and is, in essence, a protective device, not only for the patient but also for the machine. It requires very slight pressure to stop all rotary motion.

Figure 10 shows the control; the desk was obtained from High Voltage Engineering Company to match a Van de Graaff control, which is opposite. The section of the control to the left is very useful because it reads output, total time, and roentgens; if these were cents per gallon, number of gallons, and total cost, you would readily recognize it for what it is, a meter from a gas pump. It works very nicely for our purpose.

There are also the usual controls, protective devices, an indicator showing where the rotation is, loudspeaker communicating system, emergency stopping switch, reversing devices, and a continuous monitor of the amount of radiation at one particular point in the room. The observation window, 18 in. thick, is a tank containing an almost saturated solution of zinc bromide. We were forced to put drapes over this window because the visibility was too good and the patients complained that people walking by were looking at them.

The first patient was treated in April 1954; however, since this unit is used for patients only half time, the other half being occupied with biological research, only 92 patients have been treated to date. We have formed certain general impressions, but they are not relevant to this part of my presentation.

There was one period of breakdown, lasting three days, caused by dirt on the six collimator rings on the inside of the large supporting rings. No other difficulties have been experienced, and with a single exception, that of the limitation in maximum field size to 15 by 15, we have been satisfied with the unit. Since we also have a 2,000,000-volt Van de Graaff generator, we can obtain larger field sizes on that unit.

We have not yet found need for the angular motion nor rotation motion of the couch. One other thing, the architect cheated us in one area of our ceiling, and we would find it unwise to rotate with the head angled out because of one area where the protection is not sufficient.

Our new source will probably not be a solid one but will probably be pellets for efficiency in the pile. We hope within about six months to a year to have a source of 200 curies/g in the same size.

When Dr. Brucer invited me to participate in this meeting, he asked me to describe this unit and also to talk about moving-field therapy, but he did not tell me that he was going to pin me down to indications. When I saw the program, I was somewhat disturbed. Webster's Dictionary defines the medical use of the word "indication" as "any symptom or occurrence in a disease which serves to direct to suitable remedies." After looking that one over, I felt even more sad about the whole matter.

At any rate, it will probably not startle any of you if I begin by saying that I can find very few, if any, indications for moving-field therapy. If I had not seen the instructions for this evening's meeting, I would

probably not make such a statement; but, if we consider moving-field therapy in the light of what it can accomplish that could not be done otherwise, there seem to be very few strict indications for its use.

Why, then, has it become so popular and widespread? Well, first, let us dispose of radiation in the ordinary range of 200 to 250 kv. In pelvic lesions, some lesions of the esophagus, and some of the cranial cavity, such as pituitary adenomas, the delivery of an adequate dose is simplified, and the adverse reactions in the patient are minimized. It is possible to spare skin and neighboring structures, and one is not put to the arduous task of planning the multiple-beam directed fields needed for the adequate dose in these areas. Basically, it is easier on the patient and the radiotherapist, but I do not think it is easier on the physicist, from what we heard this morning.

It has been said that moving-field therapy is not at its best at 250 kv but that 250 kv is at its best with moving-field therapy. I do not know the author of this statement, but I am inclined to agree with him because in most instances the best use of moving-field therapy is in conjunction with supervoltage.

It would be presumptuous of me to describe the various methods of moving-field therapy. The descriptive terms used by Smithers, long-axis and short-axis rotation, are clear and understandable to me. Perhaps spiral short-axis rotation could be added to fit the particular development of the German groups. Smithers, as have others, states that rotational therapy is merely a technical trick that provides easier administration of adequate tumor dose to deep lesions.

In addition, he points out that the advantages of supervoltage radiation are not only greater penetration but also lower integral dose, skin sparing, sharper localization, and (probably of prime importance) the avoidance of differential absorption in tissue.

On the other hand, and this was mentioned this morning, Watson and colleagues do not believe that there is any advantage in supervoltage rotation over beam-directed small-field therapy. They think that the advantage of rotational therapy is in the improvement of depth dose at conventional levels, and I think that they are in the minority in this opinion. It seems quite clear that rotation and high-energy radiations are complementary in many instances.

There seems to be rather general agreement among those who have used rotational therapy in its various forms as to what lesions should be treated. The overall emphasis is on the esophagus and lesions of the pelvis, particularly carcinoma of the urinary bladder. Nielsen has for many years treated carcinoma of the esophagus by rotation, albeit at conventional voltage levels.

There have been a number of reports on the value of supervoltage in increasing the parametrial and pelvic-wall dose in carcinoma of the cervix. It has been stated that lesions in all parts of the body have been treated by supervoltage radiation.

Among others mentioned are larynx and thyroid, and I am somewhat at a loss to understand the advantage of rotation in these particular instances. Laryngeal



Fig. 6—Patient being assisted to treatment couch.



Fig. 7—Treatment with the beam horizontal.



Fig. 8—Treatment; note rotation of head from Fig. 7.



Fig. 9—Treatment; rotation completed.

lesions are readily managed by fixed-portal radiation, and, to me, thyroid lesions do not seem to be amenable to supervoltage.

In any event, in the enthusiasm for rotational therapy there is great danger of going overboard. Granted

It is hardly necessary to mention the great advantage of teletherapy equipment for this type of treatment. As a matter of fact, continuous rotation about the horizontal patient by any other means would be impossible. In short-axis rotation, our cobalt unit



Fig. 10—Control panel. At the left are shown from top to bottom the dose, the time, and the output at the axis of rotation.

that very complicated arrangements of moving fields can produce extremely bizarre patterns of isodoses in tissue, one still has to balance off the arduous work done to achieve such patterns with what is known about disease process. Many such complicated procedures are worthless because of the obvious limitations in our ability to diagnose the exact extent of the malignancy.

At present we have limited ourselves to two types of moving-field therapy. The first is long-axis therapy with the patient recumbent, because of the design of our cobalt unit. Second, we have modified our rotational treatment platform, which was part of our Van de Graaff, so that we can do short-axis treatment, and only with great effort can we convert back to long-axis methods.

These two methods cover nearly all the lesions that we now want to treat by rotation. The major number of long-axis cases are better handled, from a standpoint of accuracy and patient comfort, when they are done in the supine and prone positions.

does not lend itself readily, and we have found it more feasible to use the Van de Graaff.

In general, we have agreed with others in the selection of patients, both for supervoltage and for rotation. At first, because they were readily observable, we concentrated on lesions of the head and neck, as have several other centers. The esophagus was another obvious lesion where the method could be used to advantage.

We have not treated pulmonary lesions since most of the lesions that we see, as has been the experience of others, are so extensive that we obtain better dose distribution for palliation with two or three portals. We have done some work in carcinoma of the uterus, both cervix and corpus, and have been pleased with the short-time results.

Bladder lesions, although our Genito-Urinary Department is not radiation minded, have been most promising. Pituitary tumors are ideal, as are some localized nasopharyngeal tumors. In general, deep-seated tumors, pelvic lesions, and sharply localized

tumors of the head and neck, with the exception of the larynx, have suited our requirements for rotational therapy. I know that many will disagree with a lot of these opinions.

We have recently had the opportunity to hear from a German researcher in radiotherapy on the value of pendulum therapy in the relief of pyloric obstruction in inoperable gastric malignancy. The results presented were excellent, and the method was rather simple. We propose to start such treatments soon.

In the United States we frequently see patients who have received low-voltage, 100 to 140 kv, irradiation for deep-seated sensitive lesions, such as lymphosarcoma or Hodgkin's disease of the abdomen. I need not explain the lack of thought that is behind such treatment. These patients have skin that shows severe radiation changes and have ample tolerance to additional radiation in the normal structures in the regions of their tumors. Such cases are ideal for super-voltage rotation.

good palliation in far-advanced cancer without deleterious side-effects. Large volumes of tissue can be treated with good results. Fine examples are the treatment of stage IV carcinoma of the cervix, late carcinoma of the bladder, and the palliation obtainable in obstructed esophageal lesions.

In the practice of radiotherapy, we are too often impressed with cure rates and frequently forget the great alleviation of human suffering to be obtained by judicious use of our modality. Palliation of malignant disease can be the most important single advantage of moving-field therapy.

Figure 11 shows something that Allen Jennings, using our cobalt unit, has recently developed for the treatment of the parametrial areas. There are two 85-deg sectors on either side of the pelvis. I do not know why we did it this way (it is perhaps gilding the lily to divide this sector), but we wished to spare the femoral head and neck area. Since we get a fairly adequate dose in the region of the pelvic wall by this

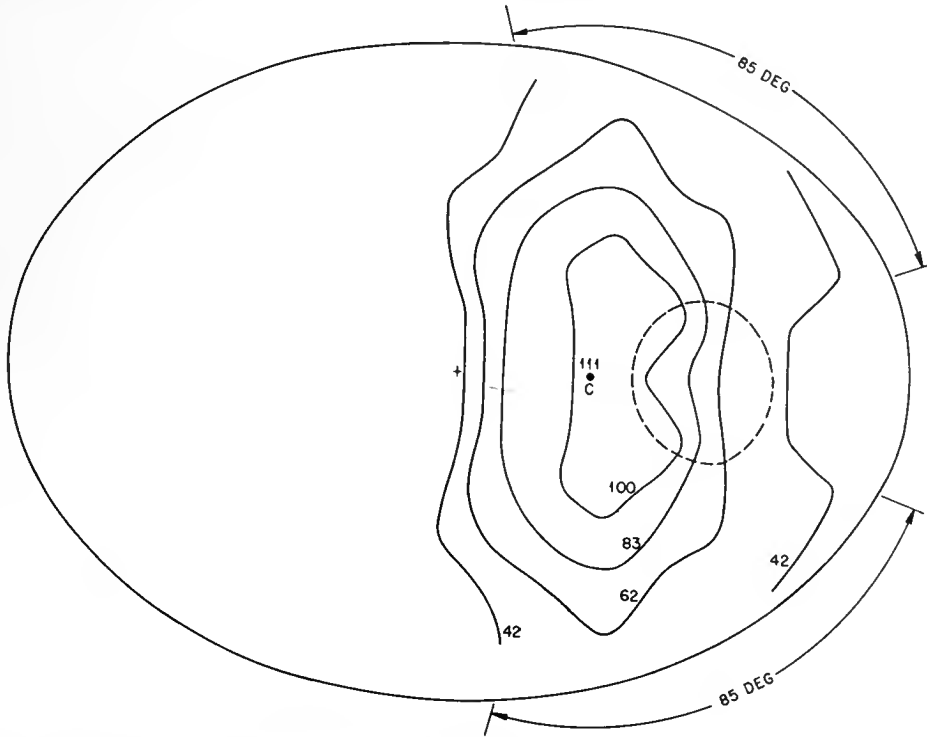

Fig. 11—Isodose pattern for split-sector rotation for carcinoma of cervix with the Argonne Co⁶⁰ teletherapy unit. Phantom ellipse, 24 by 34 cm; two 85-deg sectors; 8- by 15-cm field; C, center of rotation; 81.5-cm radius of rotation.

In all the literature on moving-field therapy, recurring statements appear about its advantages in sparing the usual adverse reactions in the patients. There is less skin damage, less general reaction, and, in pelvic lesions, less bowel difficulty and so forth.

We are convinced that the basic tenet of radiation therapy must be that we do something for the patient rather than something to him. One of the chief advantages in rotational therapy is its ability to apply

method and a good dose at the center of rotation, we think that it may have some application. We have used this on only one patient, and I have nothing to report on its ability to handle disease.

Since Dr. Jennings comes from the Royal Northern, I do not need to explain Fig. 12 to many people. This is conical therapy, using a wax cone. The beams are aimed at the center of the lesion, 100 cm focal-to-skin distance, 5-cm-diameter portal, 18-cm radius

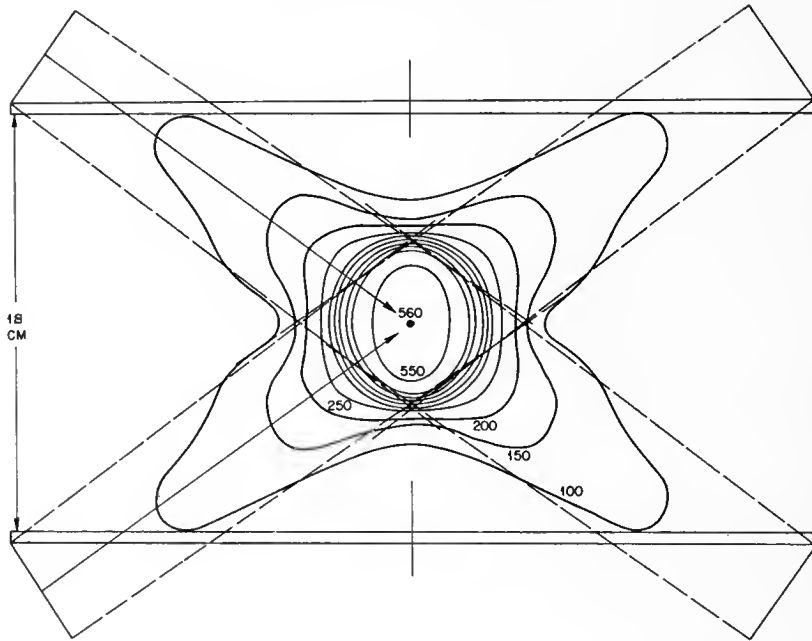

Fig. 12—Two-sided conical short-axis rotation with wax cone using the Van de Graaff unit. Beams are aimed at lesion center at mid-point; 100-cm FSD; 5-cm-diameter portal; 18-cm cone radius; 34-deg angle; 360-deg rotation; 2 Mv. Dose contours are at 50 per cent intervals except at the center. (By courtesy of W. A. Jennings and A. McCrea, Argonne Cancer Research Hospital, University of Chicago.)

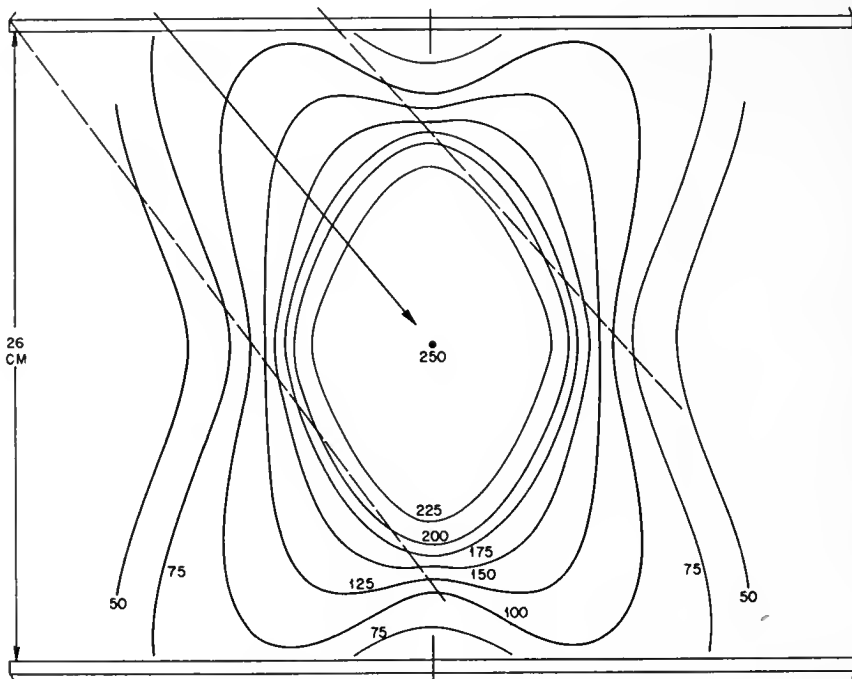

Fig. 13—Two-sided conical short-axis rotation with wax cone using the Van de Graaff unit. Beams are aimed at lesion center at mid-point; 100-cm FSD; 10-cm-diameter portal; 18-cm cone radius; 50-deg angle; 360-deg rotation; 2 Mv. Dose contours are at 25 per cent intervals. (By courtesy of W. A. Jennings and A. McCrea, Argonne Cancer Research Hospital, University of Chicago.)

of the cone, 34-deg angle, 360-deg rotation. You see the nice pattern and high central dose obtained from an application of this sort. This is for a lesion located midway.

and that one should localize it and see what happened in the prone and supine positions because it is necessary to turn the patient over. Fortunately for my argument, the first patient had a bladder that moved

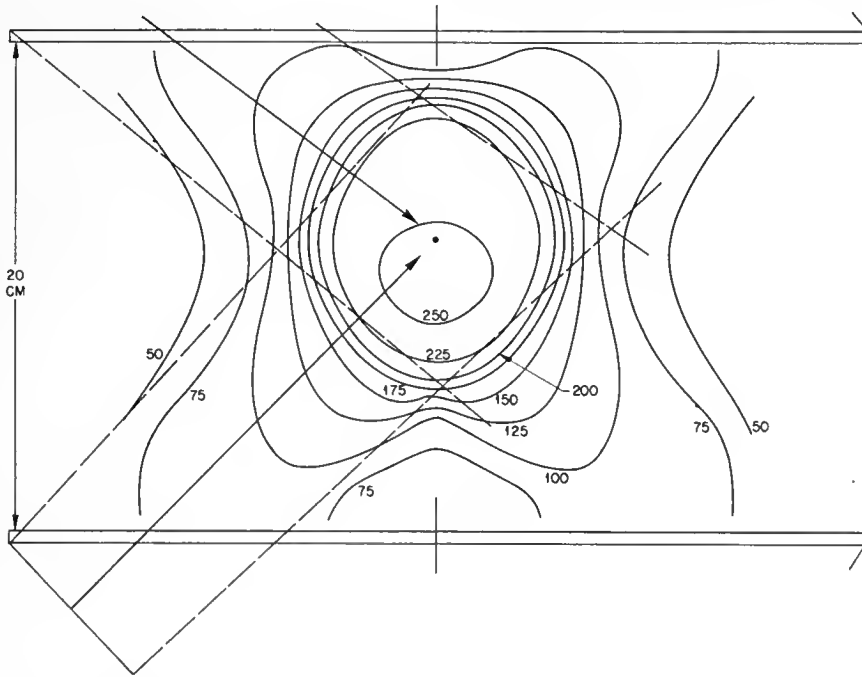

Fig. 14—Two-sided conical short-axis rotation with wax cone using the Van de Graaff unit. Non-central lesion, e.g., bladder; beams aimed at lesion center from each side; 100-cm FSD; 7.5-cm-diameter portal; 18-cm cone radius; 360-deg rotation; 37- and 45-deg angles; 2 Mv. Dose contours are at 25 per cent intervals. (By courtesy of W. A. Jennings and A. McCrea, Argonne Cancer Research Hospital, University of Chicago.)

If one enlarges the diameter of the portal to 10 cm (Fig. 13), the isodose pattern becomes elongated from front to back, and the advantages are not quite so great.

If one assumes that the bladder lies at a point two-fifths of the way along the anteroposterior diameter, then with different angles front and back, 37 and 45 deg, respectively, one can achieve an isodose pattern of the sort illustrated in Fig. 14. According to Jennings, they are no longer localizing bladder lesions at his institution. I argued that the bladder could move

7 cm, and I think that we will continue to inject opaque material and obtain films at 90 deg to study the motion of the bladder.

In summary, there appears to be general agreement that rotational therapy is a means of increasing tumor dose and sparing normal tissue. Rotational or moving-field therapy is useful in lesions of the pelvis, in other deep-seated lesions, limited lesions of the head and neck, and in re-treatment where skin damage is associated with inadequate tumor dose. Finally, it has a very great advantage in true palliation.

Contraindications to Moving-field Therapy

CHAPTER 27

Frank Ellis

Oxford United Hospitals
Oxford, England

The aim of radiotherapy is to give as high a dose to the tumor as is compatible with normal tissue tolerance, to give as low a dose as possible to the nontumor volume, and to give as low an integral dose as possible. We therefore ought to consider critical levels of nontumor-volume doses and critical levels of integral doses.

For the nontumor volume the critical dose for most tissues with 250-kv therapy should be of the order of 3000 rads, which, assuming a relative biological effectiveness factor of 0.85, would fit in with the dose of about 3500 rads with high-energy beams. This will allow the patient to get by without suffering unduly from subsequent clinical manifestations of radiation damage.

For the lung I consider the critical dose to be much lower: 2500 rads for 250-kv radiation and probably 3000 rads for high-energy beams.

The integral dose is not of great importance as long as it remains below a level between 25 and 30 Mrads. After these integral doses the patient recovers completely with no obvious signs of general damage.

The integral dose does vary; other things being equal, it is larger in moving-beam therapy than in fixed-beam therapy because of the elliptical shape of the body. If the integral dose for a cylinder can be compared with that for an elliptical body with diameters of the ratio of 3 to 2, the integral doses are in the ratio of 1.47 to 1 when a small field (3 cm wide) is used.

There is no doubt about the superiority of super-voltage radiation, as compared with 250 kv, for keeping down the dose in the nontumor volume.

Figure 1 is a diagram published by Milton Friedman comparing 2-Mv and 22-Mv dosage distributions around the rotation axis. Notice the similarity in dosage outside the tumor volume for a field 3 cm in diameter. Compare these curves with those for 200 kv. The dose 3 cm away from the axis is almost twice as high. With 200 kv the distribution of dosage in the tumor is poor, and the dose in normal tissues is high.

Figure 2 (also from Friedman) shows the same comparison for greater distances from the axis and different-size fields. It is noted that for large fields there is an advantage for 22 Mv over 2 Mv in the nontumor volume, but this is relatively slight compared with the advantage of both over 200 kv with regard to the ratio of tumor dose to nontumor dose. With a 200-kv beam the tissue dose at any point in the nontumor volume is at least of the order of half that given to the tumor volume. Thus, with a tumor dose of about 5000 rads in treatment of the chest, most of the lung receives a dose higher than 2500 rads. This dose will produce fibrotic changes, reducing the respiratory efficiency of the patient a year or two after treatment.

Table 1 shows the relation of the total integral dose to the proportion of integral dose in the tumor volume and to skin doses for a rotation technique. Except for a very wide beam, the integral dose does not approach what I consider the critical integral dose. The percentage of the integral dose in the tumor volume is very low for the narrow beam but rises for wider beams. In the 10-cm-diameter field the level of the critical local dose for the lungs, as I have defined it, is reached.

Kligerman¹ stated that one should not use a field greater than 10 cm in diameter when treating the chest by rotation. I shall make this value lower. One should not use, with 250 kv, a beam greater than 7 cm in diameter in the chest.

Figure 3 is a diagram from Kligerman's paper¹ illustrating his method of achieving a better tumor-dose distribution with 250-kv rotation. He contrasts 360-deg rotation with a fixed field and partial scanning. He has calculated doses for the tumor and part of the skin but not for the region between. From what I have said, you realize that it is important to know what the dose distribution is throughout the entire irradiated volume.

Figure 4 is also from Kligerman's paper.¹ Again there are no doses calculated for points between the tumor and the skin, and I think these other regions

are important. A better distribution might be obtained with complete rotation rather than with two 120-deg scanning fields.

Table 1—STUDY OF INTEGRAL DOSE FOR 300-KV IRRADIATION WITH ROTATION*

For 4000 rads at tumor			
Field size, cm	Total integral dose, Mg-rads	Tumor volume dose, % of total	Skin dose, rads
3 × 10	18	1.8	1280
5 × 10	20	10.5	1680
7 × 10	24	21.2	2080
10 × 10	28	44.7	2520

*Half-value layer, 1.65 mm of copper; diameter of phantom, 30 cm.

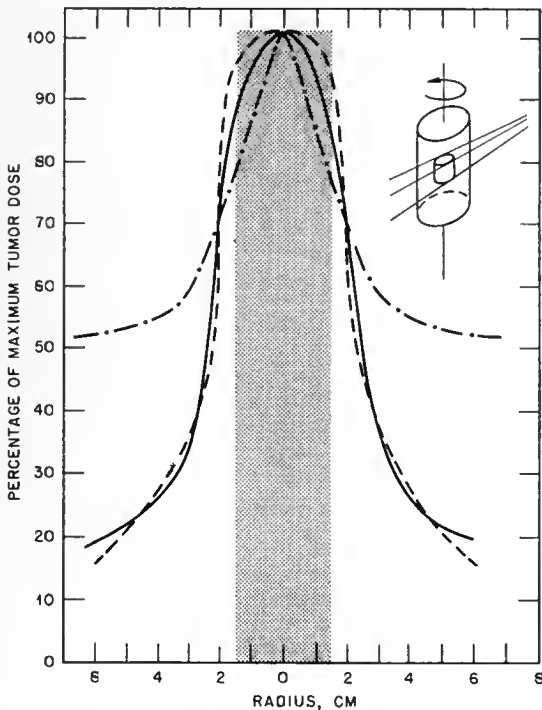

Fig. 1—Comparison of dosage distribution for 360-deg rotation with 200 kv (— · — ·), 2 Mv (— — —), and 22 Mv (- - - -), using a 3-cm-diameter portal in a 30-cm-diameter cylindrical phantom.

The critical dose to normal tissue should always be considered. It may be that the levels I have recommended are too low. An eccentric lesion is not really suitable for 250-kv rotation therapy, but it is possible, by building up with wax, to improve the distribution of the radiation.

For instance, at the thoracic inlet it is often convenient and useful to use rotation therapy for a tumor that is partly in the lower neck and partly in the upper thorax; and it is possible to maintain the same daily tumor dose of 100 rads and to diminish the dose given

to the skin at the base of the neck from 48 to 26.5 rads.

Physical considerations have been discussed previously. Inhomogeneous composition of tissues is very important. Although some people are doing work on this, it is not sufficiently considered in most departments. Study of dosage distributions throughout the tissues seems to be essential if good results with rotation therapy are to be obtained. It is not sufficient to know the dose in the tumor and at the skin. Calculation methods should be checked by measurement.

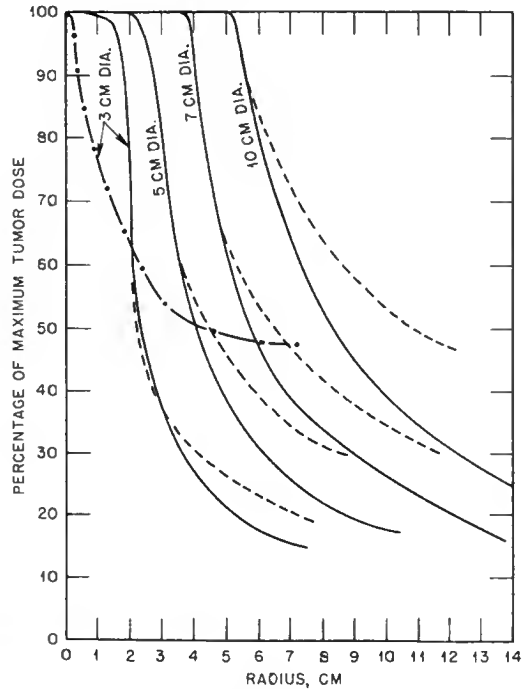

Fig. 2—Comparison of influence of portal size on dose distribution using the same factors as those in Fig. 1. —, 22 Mv. - - - -, 2 Mv. — · — ·, 200 kv.

Figure 5 shows an attempt to compare the dose distribution produced by 250-kv rotation (half-value layer, 1.65 mm of copper) with that from two arrangements of fixed fields in a body section 30 by 20 cm. The field size is 15 by 15 cm; at point P, the axis of rotation (it is a slightly eccentric lesion), the treated volume measures 19 by 19 cm. At each point designated by a letter, the top figure represents depth dose achieved by three fixed 15- by 15-cm fields; the middle figure, by four fixed 15- by 15-cm fields; and the bottom figure, by 360-deg rotation with 19 by 19 cm at the axis. There seems to be little or no advantage in rotation therapy.

Figure 6 shows a similar diagram, in which the radiation factors are also 250 kv and 1.65 mm of copper HVL. The depth dose achieved by four 10- by 10-cm fixed fields (smaller than those in Fig. 5) is represented by the upper figure, as compared with the depth dose achieved by 360-deg rotation with 12.5

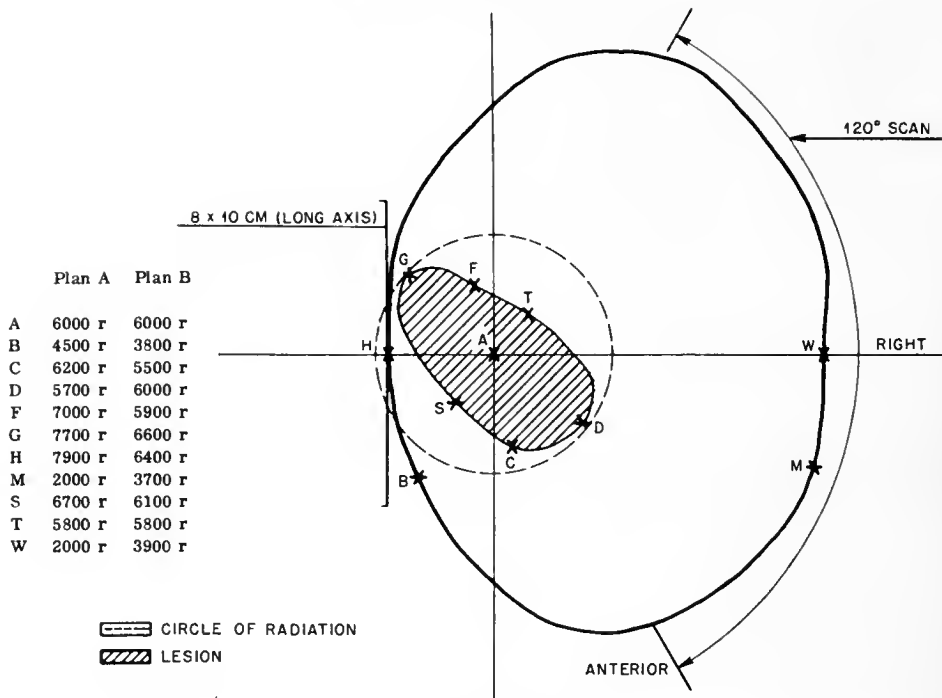

Fig. 3—Diagram by Kligerman,¹ showing dosage comparison for certain points in an arrangement of partial fixed field and partial scanning technique to treat an eccentric tumor.

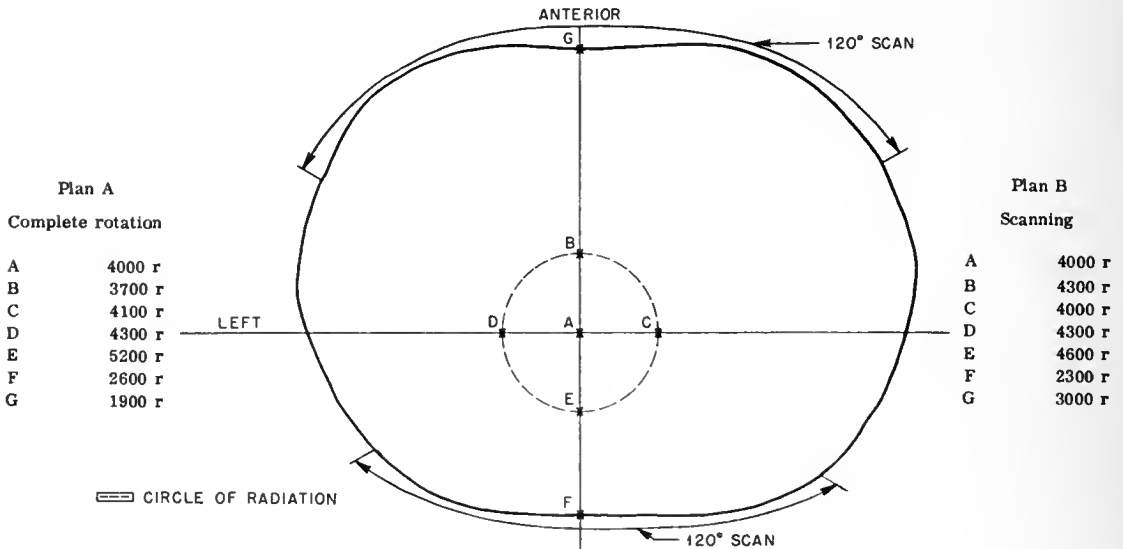

Fig. 4—Diagram by Kligerman,¹ giving comparison of dosage at certain points for complete-rotation technique compared with two 120-deg arcs.

by 12.5 cm at the axis, which is represented by the lower figure. Again, rotation therapy seems to have no advantage.

Figure 7 is a similar diagram for 7-cm-diameter fields (top figure, four fixed fields; middle figure, six fixed fields) as compared with 360-deg rotation therapy treating a volume of 8.5 by 8.5 cm at the axis with

250-kv X rays (HVL, 1.65). Even with the 7-cm fields there is no advantage of rotation over fixed-field arrangements.

On the way here in the plane I met Dr. Farmer of Newcastle, who supplied information I had been seeking. He has very kindly let me have some of his diagrams (Figs. 8 to 12). He compared rotation therapy

with fixed-beam therapy for 250-kv radiation and also with fixed-beam 4-Mv therapy (linear accelerator).

Figure 8 shows a plan for treating the bladder by a six-field method (HVL, 3.5 mm of copper), in which there are four fields around the pelvis, one perineal field, and one suprapubic field. The diagram is in the plane of the four fields, and the isodose curves are drawn taking the 80 per cent isodose as that useful for treating the tumor and the 60 per cent isodose as the one giving a critical dose to the tissues. The diagram shows that the nontumor volume receives more

addition, the isodose curves have been flattened by a graded filter. The effect is to broaden the treated volume laterally and to shorten it in the anteroposterior direction. The tumor volume irradiated is now improved, but the volume outside the tumor which is irradiated above the critical 60 per cent dose is larger than that with the fixed-field method. The integral dose is 24 Mg/5000 r.

Figure 11 shows the dose distribution when the same case is treated with a 4-Mv linear accelerator. In Newcastle, three fixed fields are used to treat the tumor volume. There is much more sparing of nontumor tissue, and the volume dose is much smaller than with 250 kv, either using fixed or moving fields. The integral dose is 13 Mg/5000 r.

Figure 12 shows the dose distribution of 250-kv irradiation with paraxial (conical) rotation using two opposing cones. This arrangement apparently gives a very good distribution in the region of the tumor and compares very favorably with the 4-Mv distribution shown in Fig. 11. It should be remembered that here the volume dose is considerably higher than that with the 4-Mv fixed fields.

Figure 13 illustrates a 250-kv six-field arrangement for treating carcinoma of the esophagus. There is excellent sparing of normal tissue. The only criticism I have is that the spinal cord lies within the area of critical dosage. I do not know whether any complications due to spinal-cord damage have arisen, but they could easily be avoided because the tumor dose is so high from these fields that one might manage with five fields. However, Professor D. W. Smithers, whose arrangement it is, may be able to tell what he thinks about this.

It appears from these figures that treatment by 360-degree rotation around the body irradiates a smaller volume than do fixed fields and that the distribution is improved when filters are used to flatten the beam in the plane of rotation if the fields are overlapped. For

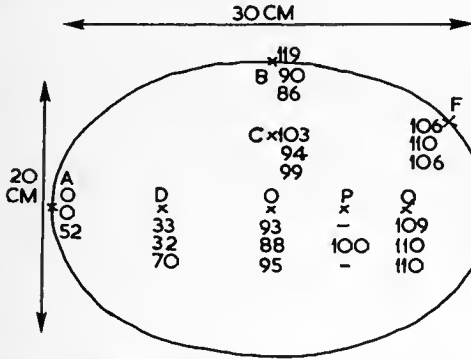

Fig. 5—Dosage distribution at certain points in a body section using 250-kv radiation.

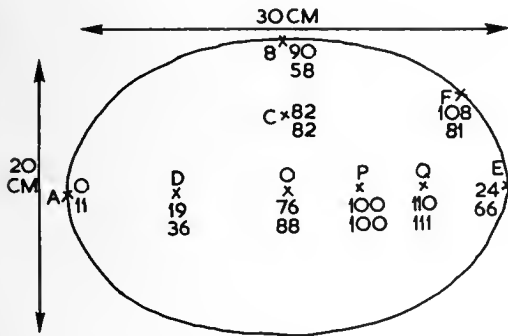

Fig. 6—Diagram showing dosage distribution at certain points in a body section using 250-kv radiation.

than the critical dose, whereas the tumor volume is irradiated to a useful dose. The integral dose is 20 Mg/5000 r to the tumor.

Figure 9 shows the same anatomical case treated by rotation (HVL, 2.5 mm of copper) through 360 deg. The field size is slightly smaller, 10 by 7 cm, and there is no flattening of the isodose curves. The nontumor volume receiving more than the critical dose is slightly smaller than that with the fixed fields, but the volume of tumor irradiated is considerably smaller and probably inadequate for this case. The integral dose is 20 Mg/5000 r.

Figure 10 shows the same patient treated with X rays (2.5 mm of copper HVL) by two 180-deg arcs, with the centers of rotation overlapping by 4 cm. In

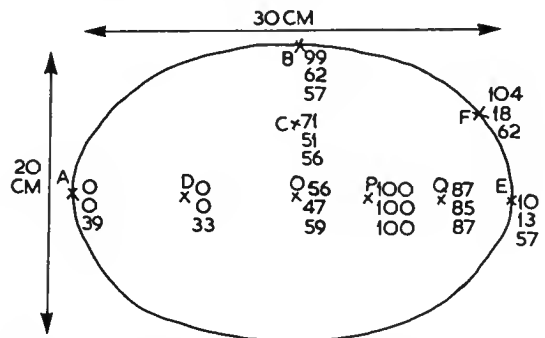

Fig. 7—Diagram showing dosage distribution at certain points in a body section using 250-kv radiation.

instance, in one case of rotation, giving a very good distribution, there was an overlapping of 4 cm of the two arcs (Fig. 10).

There is no doubt that difficulties in connection with rotation therapy can be overcome by devices such as

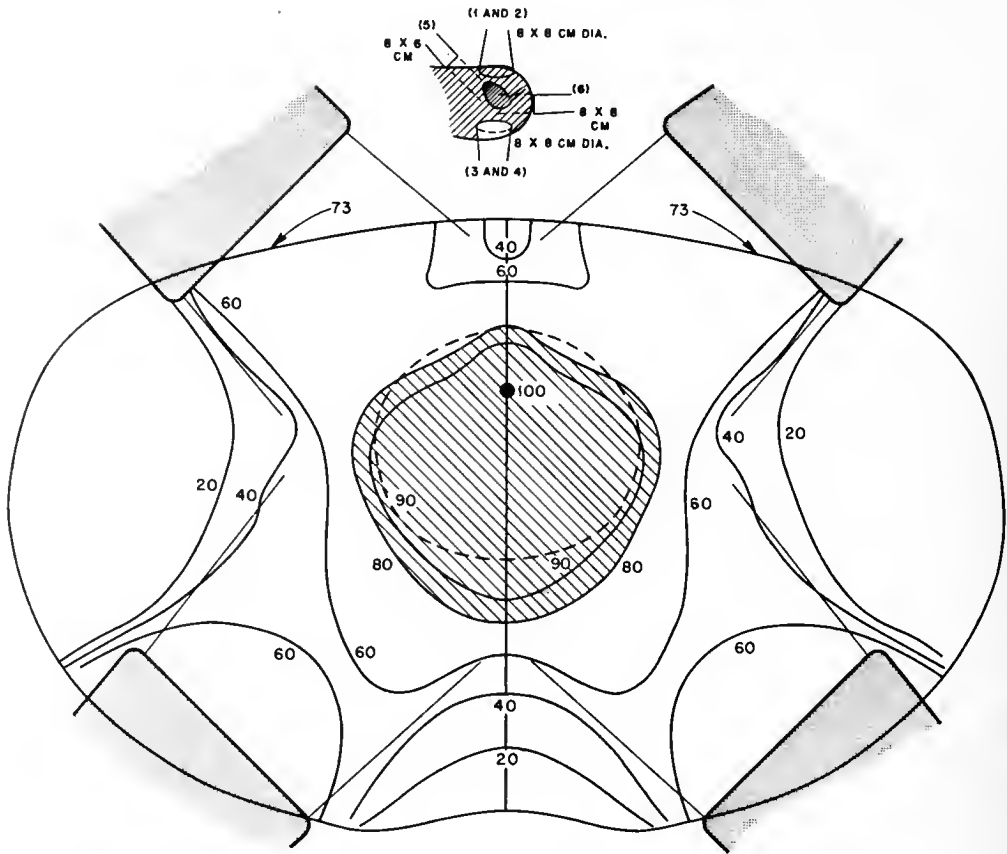

Fig. 8—Diagram showing dosage distribution (in a body section) by a six-field method (HVL, 3.5 mm of copper). The numbers are percentages.

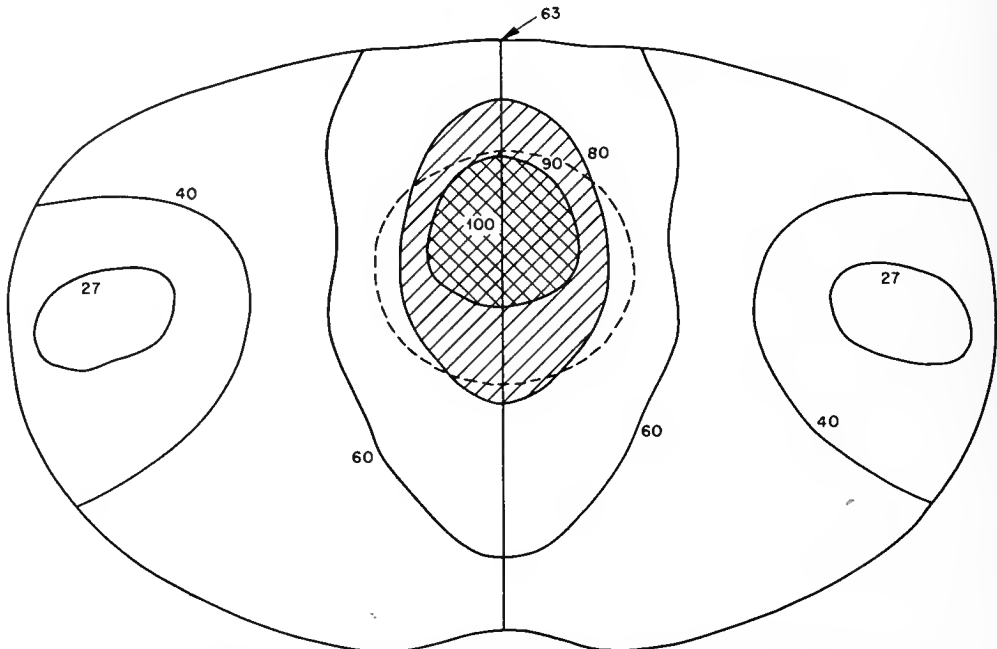

Fig. 9—Same treatment plan as that in Fig. 8 except that 360-deg rotation was used (HVL, 2.5 mm of copper). The numbers are percentages.

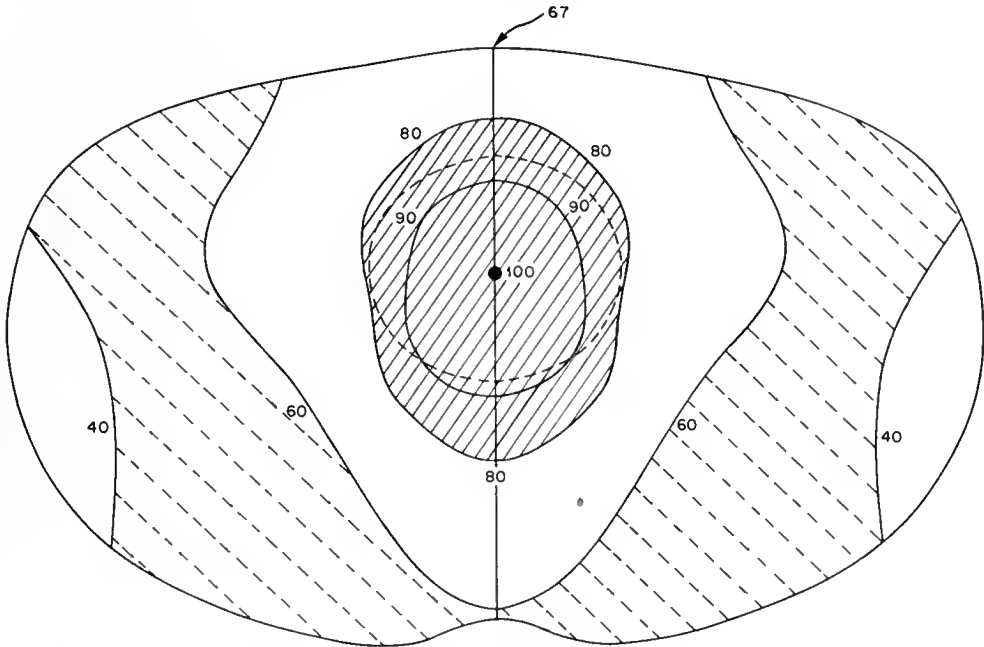

Fig. 10—Same treatment plan as that in Fig. 8 except that two 180-deg arcs were used (HVL, 2.5 mm of copper). The numbers are percentages.

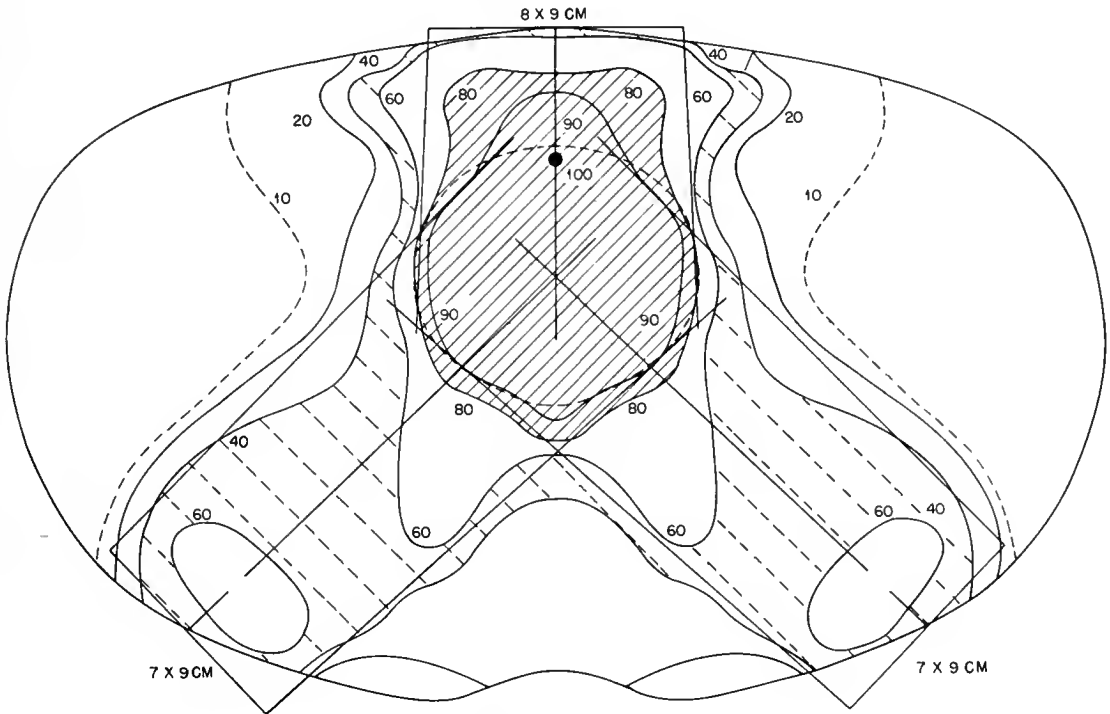

Fig. 11—Same treatment plan as that in Fig. 8 except that three fields from a 4-Mv linear accelerator were used. The numbers in the main portion of the figure are percentages.

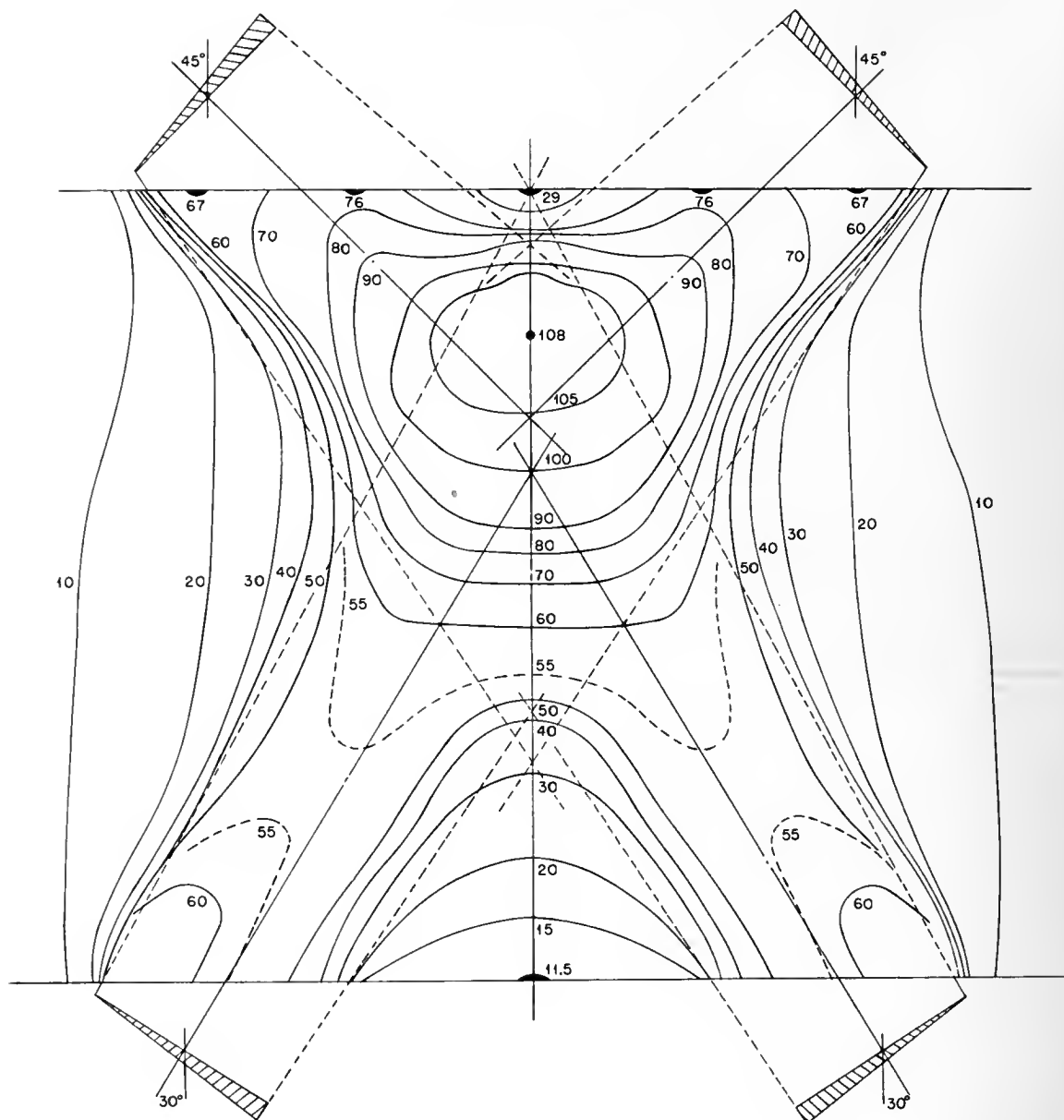

Fig. 12—Paraxial, or conical, rotation using two opposing cones (250 kv). The numbers in the main portion of the figure are percentages.

changing the position of the axis, as has already been shown by the physicists at this meeting.

I think the lower volume dose from well-collimated higher energy beams is very striking indeed.

The skin and the area receiving more than 70 per cent of the maximum dose of 100 per cent to the tumor was 250 cm² with the fixed-field method in Dr. Farmer's measurements; more than 60 per cent was given to 300 cm². With rotation, in which the flattened fields and overlapping were used, only 120 cm² received more than 60 per cent, and with the 4-Mv fixed field, less than 30 cm². Therefore, from these figures, it seems to me that there is no real advantage in ro-

tation for 200- or 250-kv radiation, except with paraxial (conical) rotation.

There are great dangers, however. It is possible, with a bad arrangement—for instance, when the axis of rotation is at the center of an eccentric tumor or when there are masses of tissue that absorb relatively more radiation than others—that the actual high-dose volume will be displaced away from the tumor and into a region of tissue, such as the lung, as a result of which the patient will suffer clinical symptoms later.

Concerning rotation with supervoltage, the slides of isodose distributions shown earlier and the two

CONTRAINDICATIONS TO MOVING-FIELD THERAPY

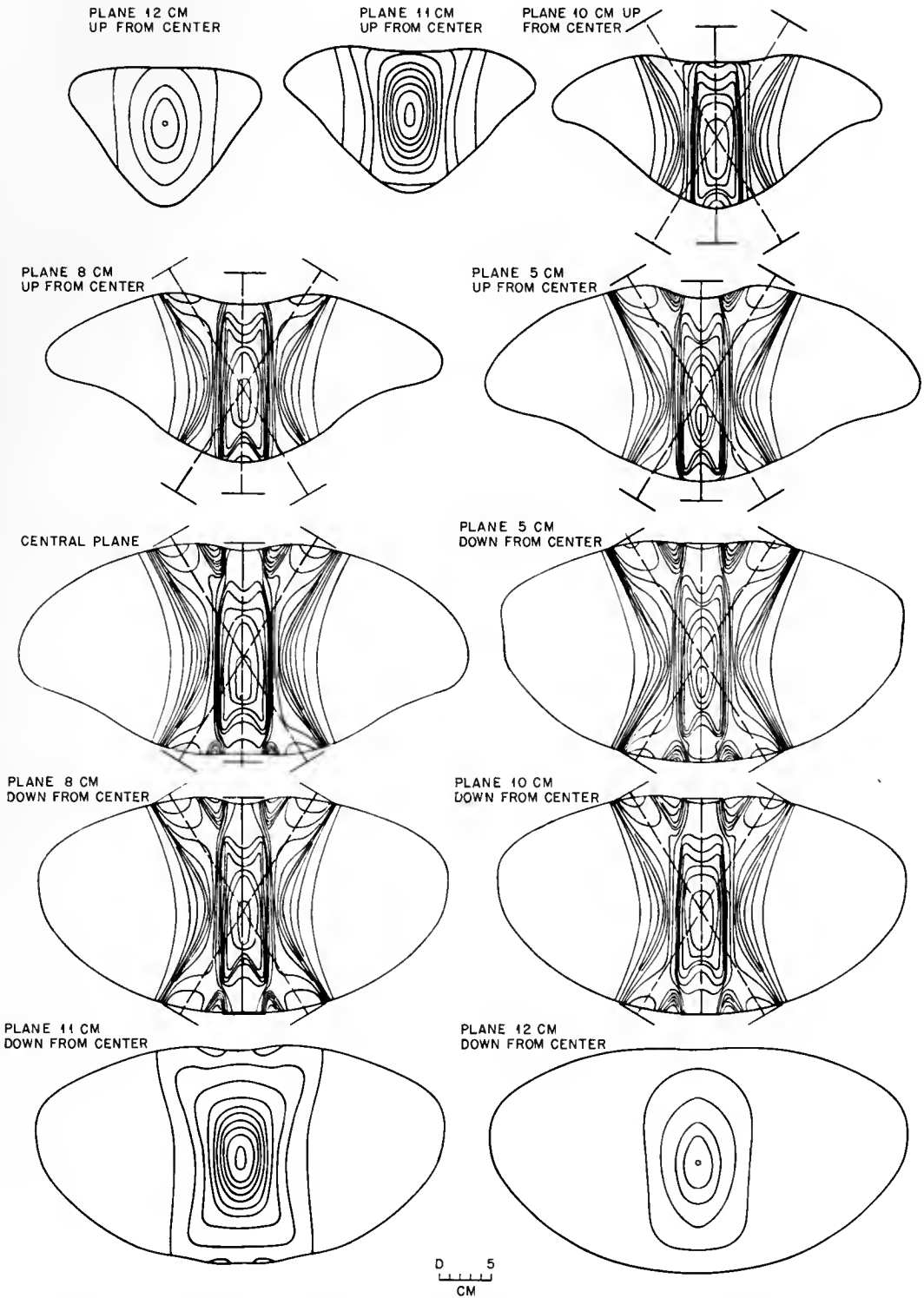

Fig. 13—Isodose distribution using six 20- by 4-cm fields for carcinoma of the esophagus (250 kv). Peak of 400 kv; focal-to-skin distance, 80 cm; HVL, 3.7 mm of copper.

graphs by Dr. Friedman indicated that rotation is an advantage for supervoltage because the high-dose volume is definitely localized; and, unless the fields are too large, the fall-off outside the tumor-volume area is quite rapid.

Great care and accuracy are obviously needed in setting up for rotation therapy. With the patient vertical, there is danger of his sagging out of position. With the patient horizontal, it is possible for him to move slightly, displacing the axis of rotation considerably. This difficulty might be overcome by some form of fixation. Thus two matters require great care: maintaining the axis at the proper place and planning the axis to be where it will give the best dosage distribution.

One of the advantages of moving-beam therapy is an easy setup, but an easy setup does not justify bad dose distribution. The errors, especially if we make a cast with seatings for the applicators, are likely to be less with fixed-beam therapy for 250-kv radiation than with rotation therapy.

The question of penumbra is very important. The penumbra contributes to the volume dose, but it also contributes considerably to the tissue dose in the non-tumor volume. Consequently, with any form of rotation therapy, the penumbra must be kept to a minimum.

Dr. Carpender mentioned the Saskatoon ideas about using rotation therapy in connection with supervoltage. Regardless of what was said a few years ago, a month or so ago Johns and his colleagues published a sizable paper in one of the American journals in which they gave all the necessary figures for carrying out rotation therapy with both 250 kv and the cobalt unit; ideas may now have changed.

Inside the skull, with 250 kv, I would not use rotation therapy for any field greater than 4 cm in diameter because the dose to the normal brain would be too high. Conical rotation to the middle ear is very

good, but I would not use circumaxial rotation for such a situation because it is too eccentric. Rotation therapy is contraindicated in the neck, with either 250 kv or a high-energy beam, because we can do as well with fixed beams without any risk to the spinal cord.

To summarize, for conventional deep therapy, apart from conical rotation, I do not like rotation therapy; after having thought about it for this meeting, I have reached these conclusions:

With supervoltage X rays there is no contraindication for rotation techniques except for the neck and in the neighborhood of the eyes.

Wedges could be used with conical rotation with profit, as indeed Dr. Carpender showed in the techniques developed in Chicago. We ought not to forget that there are alternative methods to these beam radiations, and again I must emphasize the efficient local effect of implantation of radioactive sources.

The economic aspect should be considered. If one concludes that, for low-voltage radiation, rotation therapy is not indicated, then the economic aspect does not enter. If rotation is indicated with supervoltage radiation, then the economic aspect should probably be of secondary importance. However, it is probably arguable whether it is so superior as to persuade people to spend \$60,000 to \$120,000 for apparatus.

Despite all this work, probably the most important thing is to know the size and extent of the tumor and to make sure of hitting it.

I should like to acknowledge my indebtedness to Mr. Oliver, the physicist in my department, for the help he has given in connection with this paper and to Dr. F. T. Farmer for permission to use Figs. 8 to 12.

Reference

1. M. M. Kligerman, Elaine G. Rosen, and Edith H. Quimby, *Rotation Therapy Technics Applicable to Standard Deep-X-ray Machines*, *Radiology*, 62: 183-193 (1954).

Clinical Experiences with a Moving-field Machine

CHAPTER 28

Ruth J. Guttman

Francis Delafield Hospital
New York, New York

At the Francis Delafield Hospital we have been fortunate in being able to compare a Co^{60} rotating unit not only with the conventional 250-kv machines but also with a 2,000,000-volt resonant transformer unit, which was used for stationary fields mainly.

The concept of rotation was originally applied to conventional 250-kv therapy, where the need to increase the depth dose and reduce the surface dose was essential. In this manner, rotation established itself as a useful technique and in some ways revolutionized conventional irradiation therapy.

It was inevitable that, with the advent of supervoltage equipment, the principles of rotation sooner or later would be applied. We have been working for three years with this combination in the form of a rotating Co^{60} unit.

Thus far our observations suggest one important conclusion, namely, that rotation combined with supervoltage is often a convenience but almost never an absolute necessity. What could be done only with rotation on conventional 250-kv equipment can be done with ease on stationary supervoltage units. However, my mission here is to evaluate a Co^{60} rotating unit from the point of view of the clinician, the radio-therapist.

You have heard the descriptions of many Co^{60} units; however, to evaluate my clinical experience with one of them, I should repeat the description of the machine and the way we plan treatment. This is necessary because, if a method is feasible but cumbersome and clumsy, the possibilities for mistakes are great, and therefore it is a method that should not be readily applied.

Our Co^{60} unit, the Theratron, is a relatively simple, small, compact machine which requires little more space than a conventional 250-kv unit (Fig. 1). It is possible to angle the head of the machine to either side of center for purposes of rotation or scanning or for off-center irradiation when the machine is used for stationary ports.

In all movements, the speed of the rotation unit can be controlled and modified. This is important. Sometimes when the unit rotates around the patient at great speed it is frightening, and it is therefore an excellent feature to be able to reduce the speed.

The treatment table around which the arm and head revolve makes possible the treatment of patients in the prone position. We understand the importance of this because we have treated patients in erect position on the 2,000,000-volt unit using a rotating chair. So far, in my experience, this arrangement has not been feasible. A patient, especially one in poor general condition, is often unable to maintain a position for any length of time in the chair. I must emphasize in making this statement that we treat a high percentage of very sick patients. This may be different when the patients are not in poor general condition.

I remember very clearly, and I am sure Dr. Collins will remember too, our experience in treating patients in the rotating chair for head and neck lesions or for esophageal lesions. The patients, in order to be treated for a carcinoma of the esophagus, had their arms raised out of the field of rotation. They had to clasp their hands on a supporting bar. This is a very uncomfortable position for any length of time, and we had to interrupt the short treatments on the 2,000,000-volt unit frequently to reposition the patient.

In addition, I believe that a sick patient finds the motion of the chair uncomfortable. I sat in a rotating chair for 5 minutes once and had it spin around slowly. I was not sick and I did not receive any radiation; yet I got slightly seasick, and I do not get seasick easily. I find the rotating chair a time-consuming and uncomfortable device for the patient.

All these disadvantages are overcome with the Co^{60} rotating unit. The patient can be moved easily from the stretcher to the treatment table (Fig. 2). He then can be supported easily. All the necessary motion is performed by the machine. Obviously the time needed to position the patient is lessened considerably.

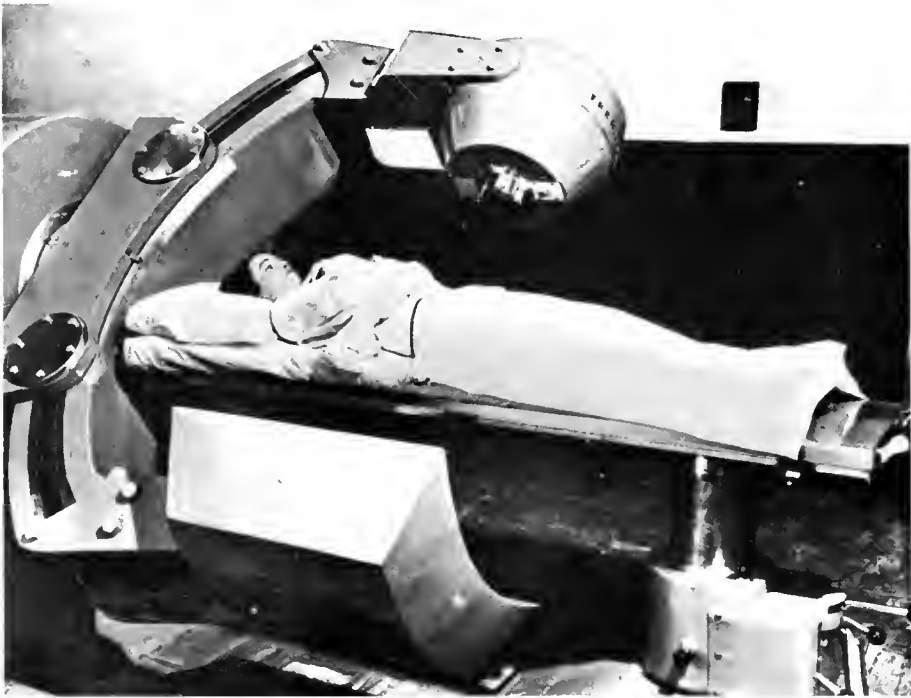

Fig. 1—The Theratron Co⁶⁰ rotation unit.



Fig. 2—Photograph demonstrating the ease with which a bed-ridden patient can be moved from stretcher to treatment table.

After the initial examination of the patient, a plaster strip contour is made of the section of the body to be treated. This is traced on transparent paper (Fig. 3). The actual contour of the patient is then traced on a piece of transparent paper. The exact position of the lesion is then traced. Contrary to the usual practice, we do not use target-to-skin distance; we use the target-to-tumor distance. Our target-to-tumor distance is 75 cm. After the model cross section has been drawn on paper, we plot isodose curves at various angles around the tumor (Fig. 4). The broken line in Fig. 4 indicates the treatment couch, which absorbs only 5 per cent, reducing the roentgen flux 5 per cent. This method only allows one to plot the dosages in the center of the tumor.

In most clinical problems it is necessary to establish also the dose at other points. These determinations may be made easily if the isodose curves are plotted in percentages of the center dose.

The use of these isodose curves in determining the off-center dose is shown in Fig. 5.

The figures found in this fashion have been checked by ionization measurements, which showed that this method is a satisfactory one. Mr. Braestrup has supplied us with a set of cones of different sizes and matching isodose patterns so that they can be used every day for our routine techniques.

We believe that we have worked out a system that can be applied readily to any situation and can be worked out accurately in a relatively short time.

In order to be certain of beam-aiming accuracy, we take localization films with the unit. Figure 6 shows the area covered by the field, but it does not come out too well. The outline of the lips, the nose, and the chin of the patient can be seen. Here a neck area is being treated, and the film indicates whether we are in the center of the field or not.

The output with our present source of 1500 curies is 47 r/min at 75 cm, which is an excellent output.

To summarize: Our rotating Co^{60} unit is easy to service, and it permits treatment with the patient in a comfortable position, which makes it easy for the patient to take the treatments. Accurate treatment planning is possible in a relatively short time.

What lesions do we treat with the Co^{60} unit? Some lesions are treated in most centers with rotational therapy, and we are no exception. We started with esophageal and bladder lesions three years ago and are still concentrating on them.

Figure 7 shows the approach with rotation in an esophageal lesion. It demonstrates that, for a dosage of 100 per cent in the esophagus, the spinal cord, which we are always worried about, will receive a great deal less than the tumor itself. The treatments are tolerated extremely well, and we have had excellent palliative results.

This is no exception from what we see when these patients are treated with 200- or 250-kv therapy. We have run a series of patients treated with a dose of 6000 r delivered with Co^{60} in six weeks. These patients were operated upon three months after completion of therapy. Usually, it is surgery first and

radiotherapy next. We reversed the procedure. The findings after surgery have been most interesting. First, the surgeons state that this major surgical procedure has not been made more difficult by the previous radiotherapy.

Second, the entire esophagus was sectioned carefully. In some there was no trace of disease in the entire esophagus, but in others the lesion appeared to be untouched. It might be said that these were different types of lesion; this is without doubt true in some instances. However, from the initial biopsy, the lesions were identical. We had two patients with practically identical lesions, moderately well differentiated squamous-cell carcinoma. One had no evidence of disease three months after therapy, and the other had active tumor. It was difficult for the pathologist to prove that the latter had any radiotherapy at all.

What is the outlook for the patient whose carcinoma of the esophagus was completely controlled by the radiotherapy? Well, next comes the important observation of which we all are aware. All these patients at the time of surgery had large positive nodes below the diaphragm, and the patient who had the primary lesion cleared, as well as the patient who had disease in the esophagus, were dead approximately fourteen months after radiotherapy and surgery; both died from generalized disease.

We have treated patients with bladder lesions with either anterior scanning or full rotation. The few patients with small lesions were irradiated with anterior scanning, but the majority of our patients who had deep invasion of the bladder were treated with full rotation.

Figure 8 shows the contour of the pelvis. Several different therapeutic approaches are indicated. First, we calculated 360-deg rotation through a 6- by 15-cm field, as used in carcinoma of the bladder. The dose to the bladder was 5520 r. For this bladder dosage, we have in the center of the pelvis 6000 r; at point B in the rectum, 4080 r; at the lateral pelvic wall, 3000 r; and in the femoral heads, 1500 r. We must think of all these points when using full rotation.

We have not seen in three years one instance of fracture of the femur. I should like to stress one important point. When treating an advanced cervix carcinoma with full rotation, it is desirable to deliver a full dose not only to the center but also to the lateral pelvic walls. A wider field than 6 by 15 cm must be used. With a small field there is a considerable decrease of dosage to the lateral pelvic walls. With a 15- by 15-cm field we could deliver the same dose to the lateral pelvic walls as to the cervix. However, with this arrangement the femoral heads receive a dose of 3840 r.

The early results in bladder treatment have been encouraging. Three patients treated early in this series have done extremely well for a year and one-half or two. Thereafter two patients had recurrent disease; the third patient is still maintaining his excellent general condition.

As far as head and neck lesions are concerned, we

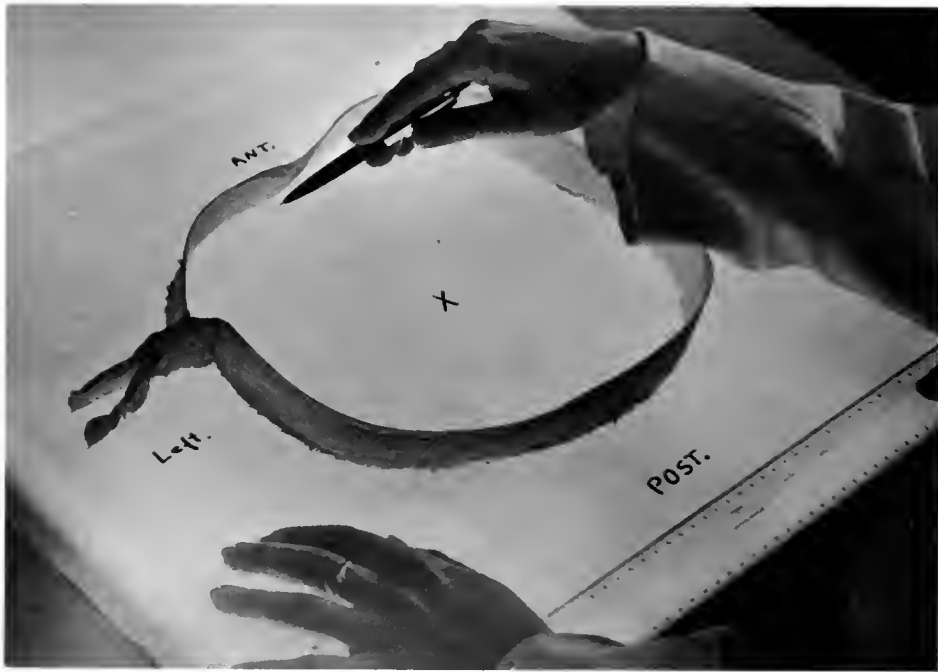

Fig. 3—Plaster of Paris strip contour being transferred to cross-section paper preliminary to dosage calculation.

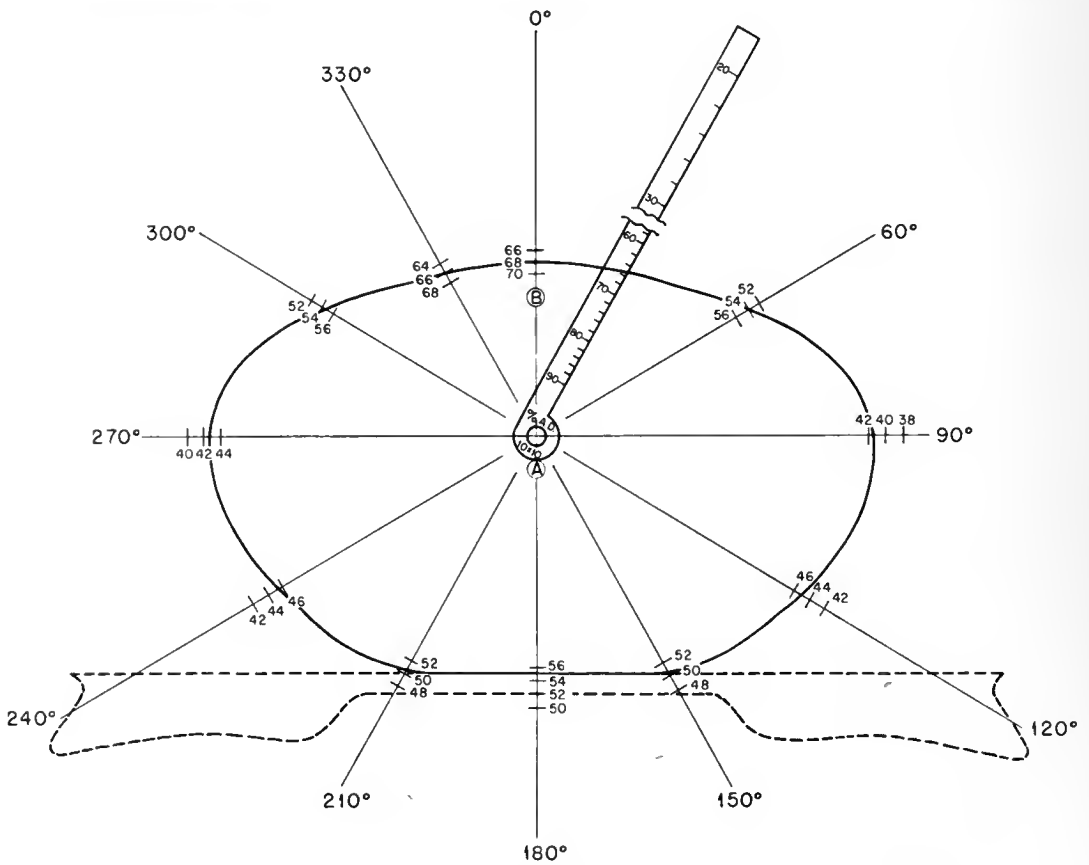

Fig. 4—Contour showing method of calculating center dose rate in rotation therapy.

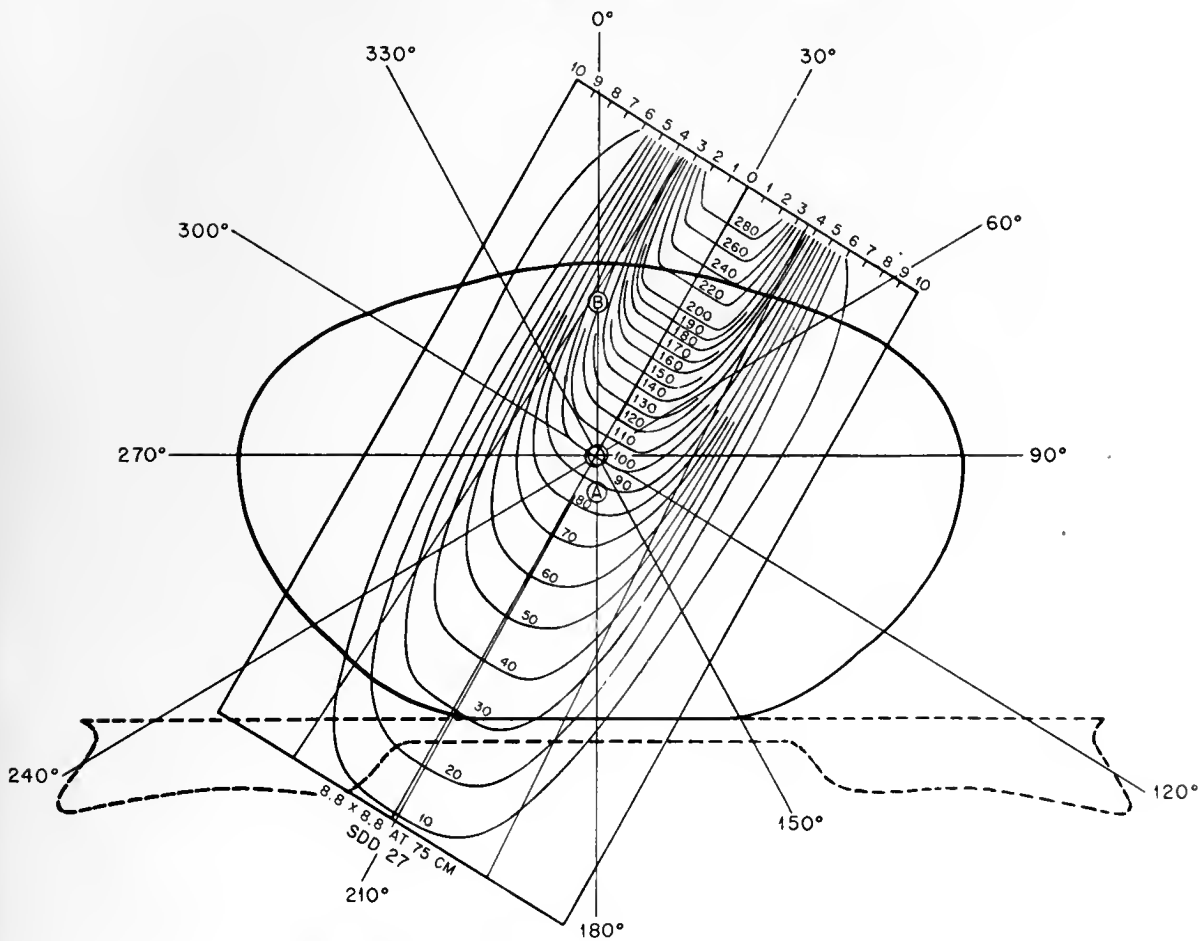

Fig. 5—Contour showing method of determining off-center dosage.



Fig. 6—Localization film taken with the Co^{60} unit of a patient being treated for a lesion of the neck. Outline of nose and lips can be seen at left.

MOVING-FIELD THERAPY

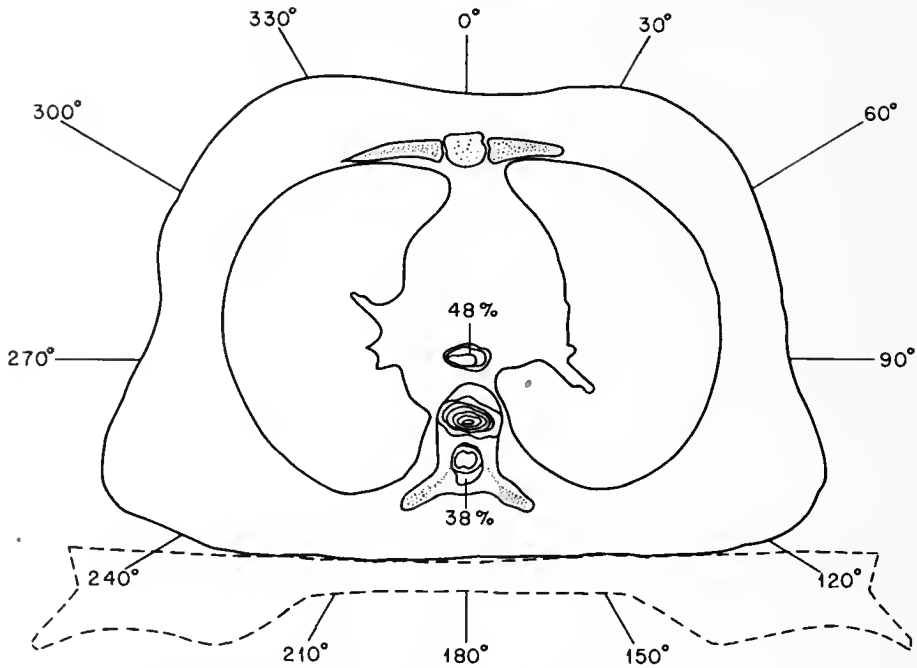
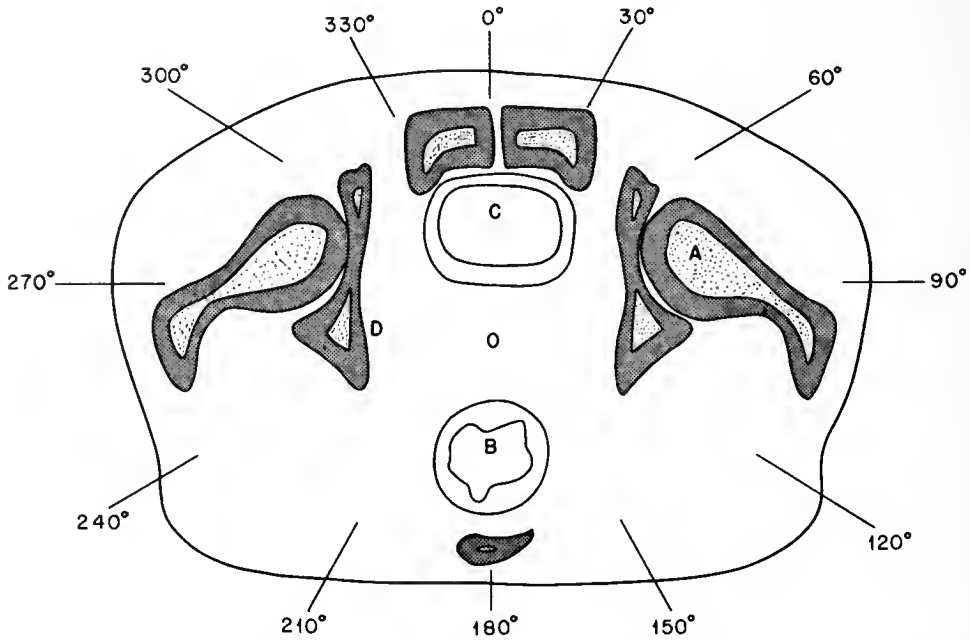

Fig. 7—Contour of a patient with a lesion of the esophagus. Values indicate dosage at various points calculated in terms of percentage of air dose. Field, 8 by 17 cm; total dose, 6000 r.



Rotation (6- by 15-cm field)				Rotation (10- by 15-cm field)				Rotation (15- by 15-cm field)				Stationary (2 opp. fields, 15 by 15 cm)				Anterior Scan (180°, 15- by 15-cm field)			
Point	R/min	%	Total	Point	R/min	%	Total	Point	R/min	%	Total	Point	R/min	%	Total	Point	R/min	%	Total
O	9.9	100	6000	O	11.1	100	6000	O	11.6	100	6000	O	13.3	100	6000	O	12.6	100	6000
C	9.1	92	5520	C	11.8	106	6300	C	11.8	102	6100	C	14.2	106	6150	C	13.9	110	6600
B	6.7	68	4080	B	10.5	95	5700	B	12.0	104	6250	B	13.9	104	6080	B	10.7	85	5150
D	4.9	50	3000	D	8.8	79	4750	D	11.4	98	5900	D	11.2	84	5050	D	12	95	5700
A	2.5	25	1500	A	4.2	38	2500	A	7.4	64	3840	A	2.0	15	900	A	8.7	69	4160

Fig. 8—Contour of pelvis with outlines of several treatment approaches and their contribution to various points throughout the pelvis.

do not have a fixed routine; we select the method of treatment most advantageous for the patient, i.e., stationary fields, scanning, or some other mode.

We have used the Co⁶⁰ rotating unit advantageously in re-treating patients. Unfortunately, we seem to get a large group of patients who have had treatment with an insufficient dose of soft radiation which left the skin in poor condition. It is extremely important to mention again that it is possible to re-treat these patients either with full rotation or with scanning.

For example, I have just re-treated a patient who two years ago was irradiated with 2-Mv X rays for an extensive carcinoma of the trachea through one stationary large field. He received at that time a tumor dose of 6000 r, the dose to the spine being 4000 r. At present the man is in excellent general condition but has local recurrent disease, which is inoperable. We worked out a treatment plan entailing an anterior scan from 75 to 285 deg. We were able to deliver a palliative dose to the primary lesion without an appreciable amount to the spine. The second course of irradiation was completed four months ago and so far has had a satisfactory result.

Evaluation should also be made of the tolerance of the patients to supervoltage rotation or some modification of it, as compared with stationary fields. There seems to be little or no difference in the general reactions these two groups produce. Radiation sickness occurs to the same relatively small extent in both modes of therapy.

As to local reactions, it is difficult to compare skin reactions in one group with the other since they are very mild in any type supervoltage treatment and do not represent a problem. If there is a difference in general or local reactions when stationary fields or rotation with supervoltage are being used, it is such a slim one that it is impossible to detect.

My conclusions in evaluating our rotating Co⁶⁰ unit from a clinician's point of view would be as follows: Within the realm of supervoltage, rotation, though often a luxury and sometimes undesirable, does facilitate treatment in many instances. The most important features of rotation therapy are that it is the ideal treatment for a centrally located tumor and that it permits re-treatment of patients who had been previously inadequately irradiated.

Clinical Experiences with a Rotating-chair Machine

CHAPTER 29

Henry L. Jaffe

Cedars of Lebanon Hospital
Los Angeles, California

Abstract

During the past eighteen months we have irradiated more than 250 patients with a cobalt teletherapy machine containing slightly more than 1 kilocurie Co^{60} as its source. The treatments were given on an electrically controlled rotating chair in the majority of cases. Some patients were also treated in the vertical and horizontal positions by the stationary single- or multiple-portal technique. When rotation was used, the patients were in the vertical position and segmental rotation therapy varied from 90 to 360 deg. The television-camera image-intensifier alignment system was used whenever possible, especially in the head, neck, and chest cases, to ensure accurate aiming of the cobalt beam. Tumor doses ranged from 5000 to 7000 r. When a large volume of tissue was irradiated, the tumor dose usually was delivered in six to eight weeks. We gave as high as 30,000 r to the pituitary gland in six weeks. This was possible because a small volume of tissue was irradiated.

Most patients tolerated cobalt rotation therapy without severe radiation sickness as long as the daily treatment dose was kept within the individual patient's tolerance. Intense skin reactions following cobalt rotation therapy were minimal compared with those which often developed after 250-kv X-ray treatment and after stationary cobalt teletherapy.

It is too early to report results. The clinical evaluation of the early posttreatment results revealed a striking primary regression of disease in those patients treated for carcinoma of the bladder, prostate, uterine cervix, and larynx.

Introduction

We have treated more than 250 cancer patients since our cobalt (1066 curies) teletherapy machine was installed eighteen months ago. Most of these patients have been treated in the vertical position by either stationary or rotation therapy. About 90 per cent of these patients received rotation therapy either by 90-, 180-, 270-, or 360-deg rotation. About 10 per cent of all patients were treated by the single and multiple stationary-field techniques.

The cases fell into certain main categories, which will be described separately.

Pituitary Radiation

A special head holder (Fig. 1) made it possible to deliver large daily and total doses of cobalt radiation to the pituitary gland by the rotation technique. We attempted to perform a radiation hypophysectomy in a few patients with advanced carcinoma of the breast who had bone and soft-tissue metastases. A total "tumor" (pituitary gland) dose of 30,000 r resulted in partial destruction of the pituitary gland in one patient. She developed diabetes insipidus, indicating that the posterior lobe had been destroyed but that a portion of the anterior lobe was still functioning. This patient tolerated treatment well. There was a loss of hair over the temporal areas because some of this treatment was delivered by stationary fields through the temporal areas. There was less hair loss when all treatment was given by rotation therapy. It was possible to deliver much larger daily tumor doses, ranging up to 1000 r, by the rotation technique since patients rarely complained of headache secondary to brain edema. These large daily doses could not be given by the stationary technique because radiation edema of the brain produces severe headaches. Radiation sickness was rarely noted with rotation irradiation of the brain, and there was no evidence of radiation damage to the optic chiasm. When stationary fields were employed, localization was checked by roentgenograms made with a wire marker on the skin (Fig. 2). When the rotation technique was used, we checked the field localization by the image-intensifier television-camera equipment.

Mr. Clark has shown the physical arrangement for those patients whose pituitary glands were treated by the rotation technique. He pointed out that the lead beads shown in Fig. 1 are superimposed in the center of the cobalt beam. Then the patient is rotated 90 deg and lined up with the television unit so that the pictures of the two lead beads become superimposed in the center of the *sella turcica*. This makes it possible during rotation to keep the cobalt beam exactly

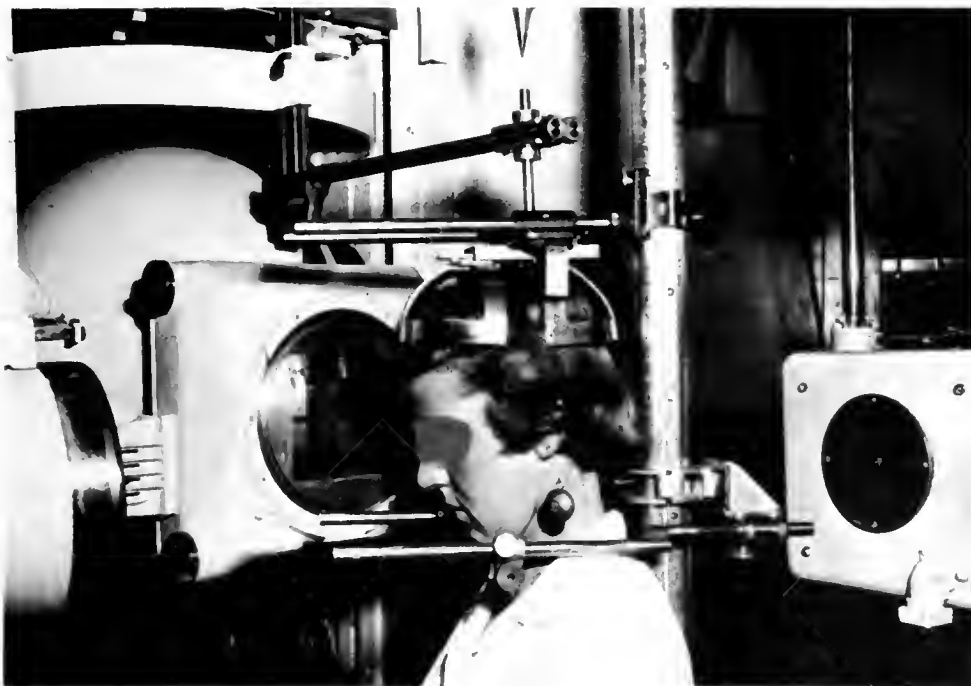

Fig. 1—Special head holder and chin holder with locking mechanism attached above to the cobalt therapy machine. The image intensifier is at the right, and the diagnostic 140-kv X-ray equipment is at the left.



Fig. 2—Roentgenogram of the skull showing the wire marker attached to the skin, corresponding to the size and location of the cobalt beam during stationary treatment of the pituitary gland.

on the pituitary gland. This control is good to within at least $\frac{1}{16}$ in. when the locking mechanism is used. The chin is in the chin holder with the head in full flexion position during the rotation treatment so that the plane through which the pituitary gland is treated is above the eyes and through a 270-deg arc. The 270-deg arc is necessary because the pole structure behind the chair is in the way.

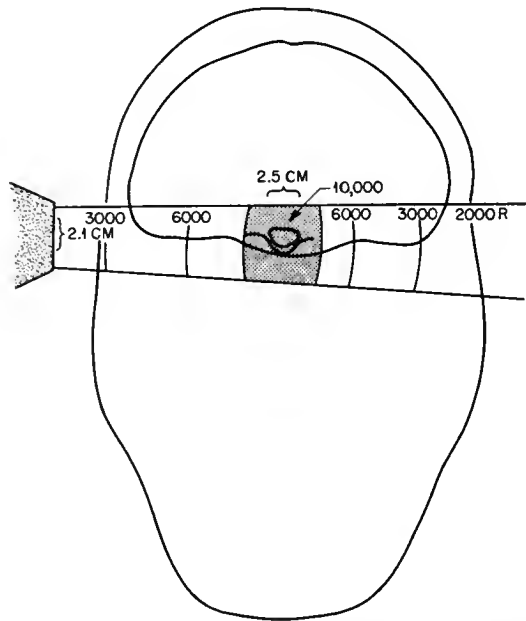

Fig. 3—Distribution of the cobalt teletherapy radiation as measured in a phantom when treatment to the pituitary gland for carcinoma of the breast was given by the 270-deg rotation technique.

Figure 3 shows the distribution of cobalt radiation therapy to the pituitary region using 270-deg rotation.

Figure 4 shows the isodose curves of the rotation and stationary cobalt radiation therapy to the pituitary gland. It is interesting to note that the integral dose is 12 Mg-r for the rotation technique vs. 11.2 Mg-r for the two stationary fields. The field size of each of the two opposing ports was 2 by 4 cm, with a source-to-skin distance (SSD) of 50 cm. The field size for the rotation circular field was 2.1 cm, with an SSD of 53 cm and a source-to-axis distance (SAD) of 60 cm. It should be noted that the surface dose is 1000 r for the rotation vs. 12,000 r for the stationary fields. Obviously, the normal brain tissue on either side of the pituitary gland receives much higher dosage of radiation by the stationary method than by the rotation method.

Neck Lesions

Patients with carcinoma of the thyroid gland and carcinoma of the larynx have been treated by rotation therapy with total tumor doses up to 5000 r in six to eight weeks. The skin reaction usually did not exceed a mild erythema, and there was little radiation sick-

ness. The edema of the laryngeal structures was much less when the rotation technique was used as compared with the edema observed following treatment by the stationary technique. When the lesion in the larynx was confined to one side, we usually rotated through a 90-deg arc. When both sides of the larynx were involved or in carcinoma of the thyroid gland, 270-deg rotation was employed.

Figure 5 shows a patient set up for treatment of carcinoma of the larynx or of the thyroid gland. The X-ray unit and the image tube, together with a television unit, are fixed in the same plane as the cobalt beam, but 90 deg out of phase.

Figure 6a is the isodose pattern for the treatment of carcinoma of the thyroid gland by 270-deg cobalt rotation therapy. This was determined by making a few measurements in a phantom and extrapolating for isodose lines. A skin field of 4 by 8 cm was used. The SSD was 57 cm, and the SAD, 60 cm. A total tumor dose of 5000 r was given in 40 treatments over an eight-week period. The approximate integral dose was 1.76 Mg-r, as compared with the integral dose of 2.3 Mg-r when the same lesion was treated (Fig. 6b) through a single anterior portal with a skin field size of 4 by 8 cm and an SSD of 50 cm.

Figure 7a is the isodose pattern for the treatment of carcinoma of the larynx by 90-deg cobalt rotation therapy, with a skin field of 4 by 8 cm, an SSD of 57 cm, and an SAD of 60 cm. A tumor dose of 5000 r was given in 37 treatments over a seven-week period; the integral dose was about 2.28 Mg-r. Figure 7b shows the dosage distribution when carcinoma of the larynx is treated through two oblique cobalt portals, each having a skin field size of 4 by 8 cm and an SSD of 50 cm. A tumor dose of 5000 r was given in 40 treatments over an eight-week period, and the integral dose was 3.04 Mg-r. A much higher dose is delivered to the spinal cord because of the overlapping of the portals than with the rotation technique.

Carcinoma of the Breast

Tangential cobalt rotation therapy through a 135-deg arc was given to include the axilla, anterior chest wall, and mediastinum. The supraclavicular region was treated either with 250-kv X rays or through a single anterior stationary cobalt teletherapy portal. The skin reaction with the rotation technique did not exceed a moderate erythema, and, when this reaction subsided, the skin was soft, slightly tanned, and without telangiectasis. Some radiation sickness was observed when the daily tumor dose exceeded 100 r. Figure 8 shows a patient set up for tangential rotation therapy following radical mastectomy for breast cancer. The axis of rotation is shifted off the axis of the beam so that a scanning effect is obtained through the patient from the anterior chest wall toward the posterior portion of the chest.

Figure 9a shows the isodose pattern for cobalt tangential rotation treatment of breast cancer, which includes the axilla, anterior chest wall, and medias-

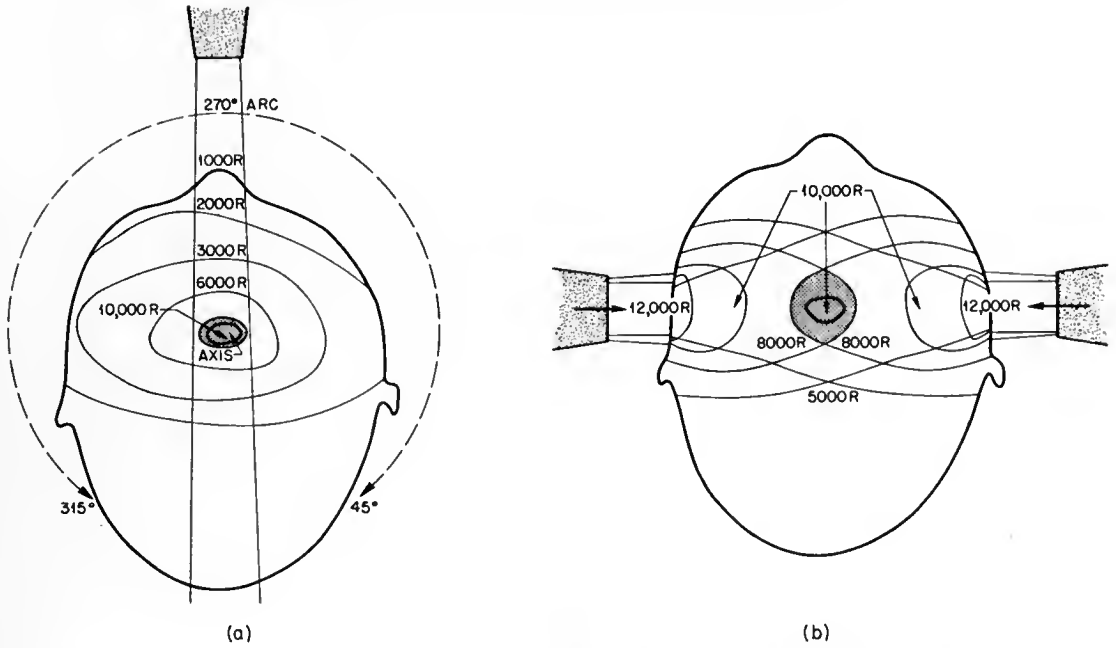

Fig. 4—Isodose curves showing distribution of cobalt radiation to the pituitary gland for carcinoma of the breast (a) with rotation therapy and (b) with two opposing stationary fields.



Fig. 5—Patient set up for treatment of carcinoma of the thyroid gland by cobalt rotation therapy. The 140-kv X-ray diagnostic unit is seen at the patient's left shoulder, and the image-intensifier fluoroscope is seen at the patient's right shoulder.

tinum. The skin field is 10 by 14 cm, with a 50-cm SSD and a 60-cm SAD. A tumor dose of 5000 r was given in 29 treatments over a period of six weeks. The integral dose was approximately 25.2 Mg-r. Figure 9b shows the general distribution of ioniza-

tion for cobalt stationary therapy through a single portal directed to the axilla through a skin field of 10 by 14 cm with an SSD of 50 cm. A tumor dose of 5000 r was given in about six weeks, and the integral dose was approximately 20.9 Mg-r.

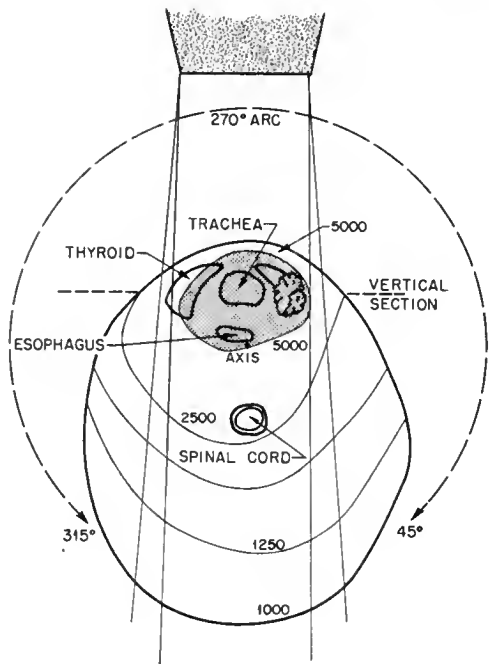

(a)

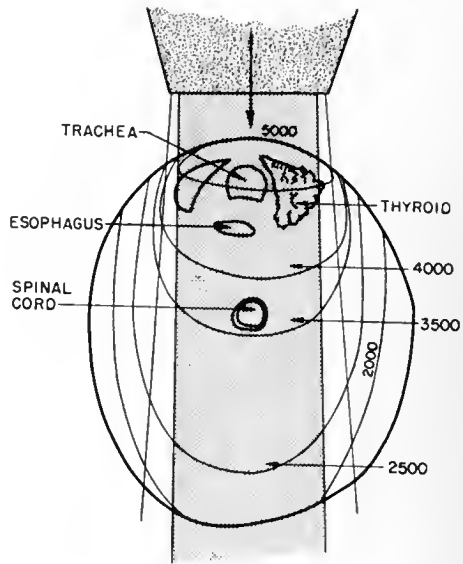

(b)

Fig. 6—Isodose pattern for cobalt therapy of carcinoma of the thyroid gland (a) using a 270-deg rotating arc and (b) using the stationary-portal treatment.

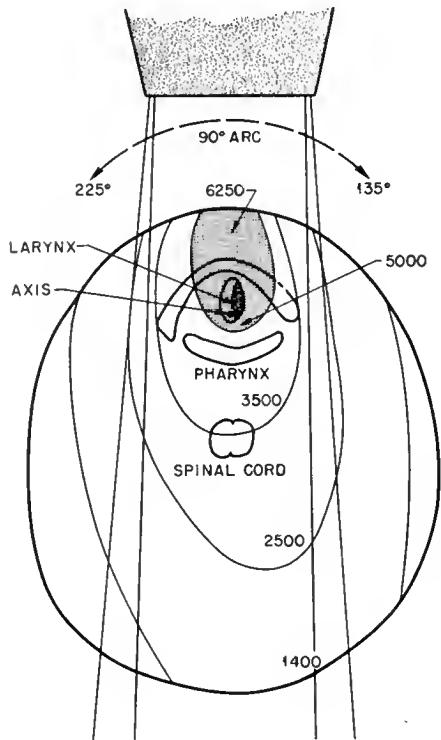

(a)

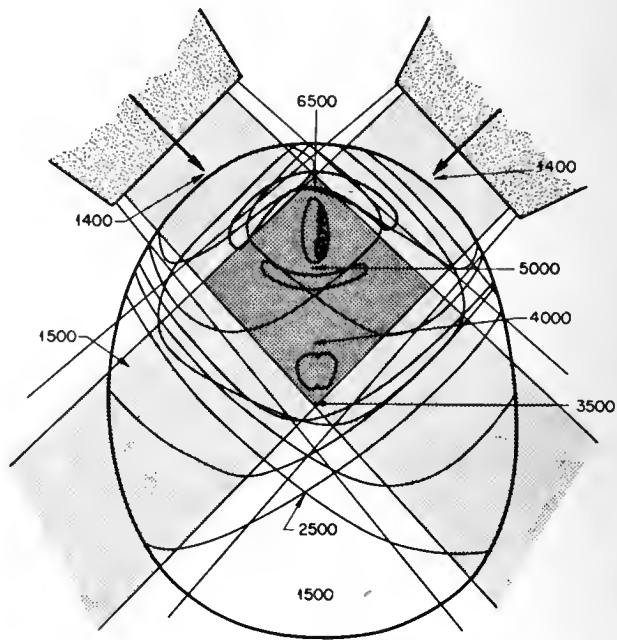

(b)

Fig. 7—Isodose pattern when cobalt rotation therapy for carcinoma of the larynx (a) is given through a 90-deg rotation arc and (b) is treated by two oblique cross-fire portals.

Carcinoma of the Esophagus

The television alignment equipment for rotation cobalt therapy of carcinoma of the esophagus proved most efficient because barium in the esophagus made it possible to visualize the lesion during treatment. In

sometimes permitted after a tumor dose of 3000 r was reached. A wire marker corresponding to the field size was placed on the skin, and a roentgenogram of the chest was made with a 125-kv unit to check the localization of the beam. After the cobalt field is aligned with our light-beam localizer, the patient is



Fig. 8—Patient set up for tangential rotation therapy following radical mastectomy for breast cancer.

this manner it was possible to control the accurate localization of the cobalt beam. Patients tolerated this type of treatment very well. When the tumor dose exceeded an average of 800 r/week, the patient complained of some dysphagia. When this complication occurred, the daily tumor dose was decreased. If the dysphagia was severe, making the ingestion of food difficult, the patient was given a rest period of one week before treatment was resumed. In general, a tumor dose of 5000 r was delivered in a period of six to eight weeks. Very little skin reaction was observed when rotation therapy was carried out through an arc of 180-deg through an anterior field. This also avoided excessive dosage to the spinal cord. The estimated integral dose was similar when rotation therapy was used to that when multiple-portal stationary therapy was employed. The dose distribution was more uniform with the rotation technique (skin field, 8 by 14 cm; SSD, 47 cm; SAD, 60 cm) than with the multiple-portal stationary technique (skin field, 6 by 14 cm; SSD, 50 cm). By shifting the axis forward, we avoided excessive dosage to the spinal cord with the rotation method; therefore the ratio of tumor dose in the esophagus to cord dose was of the order of 50 per cent or less. The integral dose was 32 Mg-r vs. 30.2 Mg-r for the stationary-field technique. This is shown in Fig. 10.

Carcinoma of the Lung

Rotation cobalt teletherapy was given through a 180-deg lateral arc over the site of the involved lung. A tumor dose of 5000 r was delivered in about six to eight weeks. Occasionally radiation sickness was observed. A rest period of one to two weeks was

rotated through 90 deg, and the roentgenogram is taken.

Figure 11a is the diagram of the dosage distribution when carcinoma of the lung is treated by cobalt rotation therapy through a 180-deg arc. The lateral aspect of the chest is scanned with a skin field measuring 10 by 14 cm. The SSD is 50 cm, and the SAD is 60 cm. A tumor dose of 5000 r was given in 38 treatments over a seven-week period, and the integral dose was approximately 31.5 Mg-r. Figure 11b is a diagram showing dosage distribution when cobalt therapy is given through a single stationary portal for carcinoma of the lung through a skin field measuring 10 by 14 cm with an SSD of 50 cm. The integral dose is 33.7 Mg-r.

When wide fields are employed, there is less advantage with rotation therapy because of the poor ratio of tumor dose to skin dose.

Carcinoma of the Bladder and Prostate

We have treated about 25 patients having extensive carcinoma of the bladder with rotation cobalt teletherapy through an anterior 180-deg arc. This has resulted in minimal first-degree skin reaction. The postradiation reactions in the bladder were less painful than with stationary cobalt therapy or 250-kv X-ray therapy. A number of patients have been followed for more than a year and appear to have benefited. Several had negative posttreatment biopsies.

We checked the localization of the beam by instilling radio-opaque material into the bladder and placing a wire marker on the skin corresponding to the field

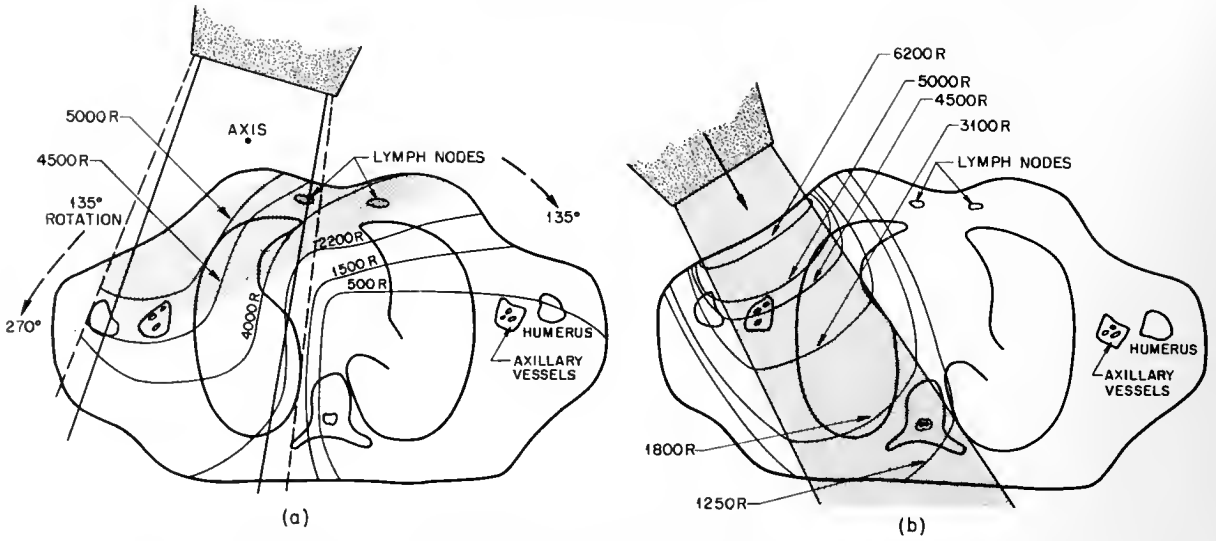

Fig. 9—Isodose pattern for (a) cobalt tangential rotation treatment of breast cancer, which includes the axilla, anterior chest wall, and mediastinum, and (b) cobalt stationary therapy through a single portal directed to the axilla.

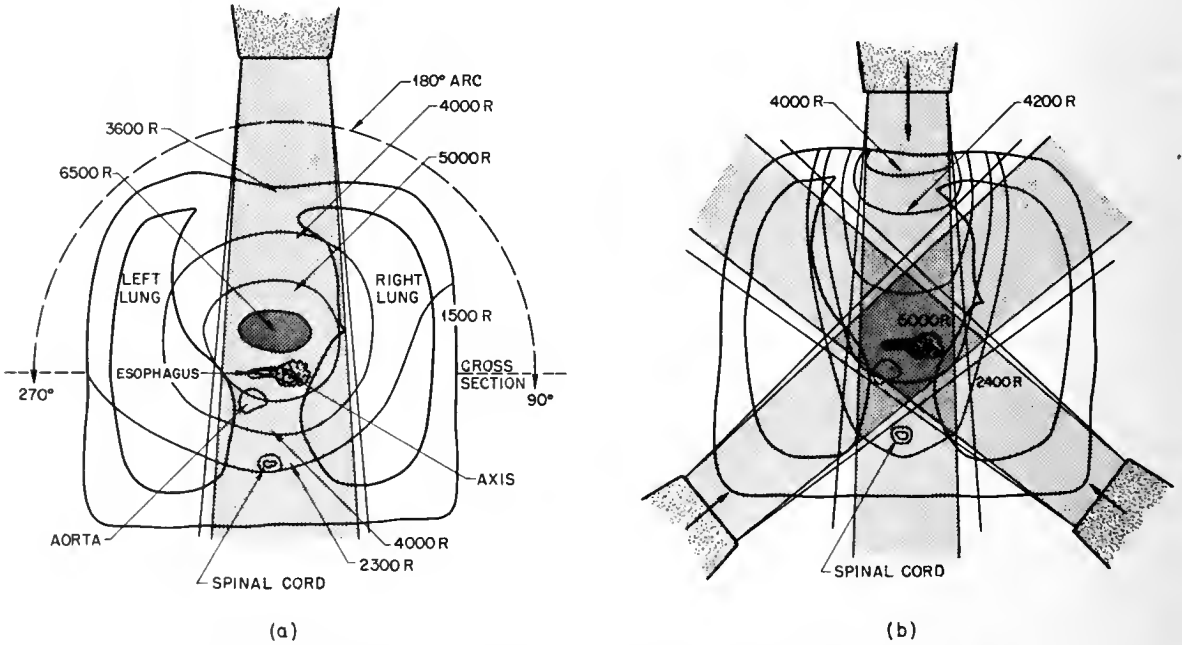

Fig. 10—Distribution of radiation when carcinoma of the esophagus is treated (a) by cobalt rotation therapy through an anterior 180-deg arc and (b) by two oblique cross-firing stationary portals.

size of the cobalt beam. A roentgenogram made while the patient is set up in the treatment position gives assurance that the size of the cobalt beam properly includes the area of treatment and a margin of surrounding normal tissue.

Figure 12 shows a patient set up for cobalt rotation therapy through an anterior field.

Figure 13a is a diagram showing the distribution of radiation dosage when carcinoma of the bladder is treated through a 180-deg anterior arc. The field size is 8 by 14 cm; SSD, 50 cm; and SAD, 60 cm. A

tumor dose of 5000 r was given in 35 treatments in seven weeks, and the integral dose was approximately 31.6 Mg-r.

Figure 13b is a diagram of radiation dosage distribution when two oblique anterior portals are used for cobalt therapy of carcinoma of the bladder by the cross-fire technique. Each skin field measured 8 by 14 cm, and the SSD was 50 cm. The integral dose was 35.6 Mg-r.

There was no severe atrophy of the skin or post-irradiation necrosis of the subcutaneous tissues after

CLINICAL EXPERIENCES WITH A ROTATING-CHAIR MACHINE

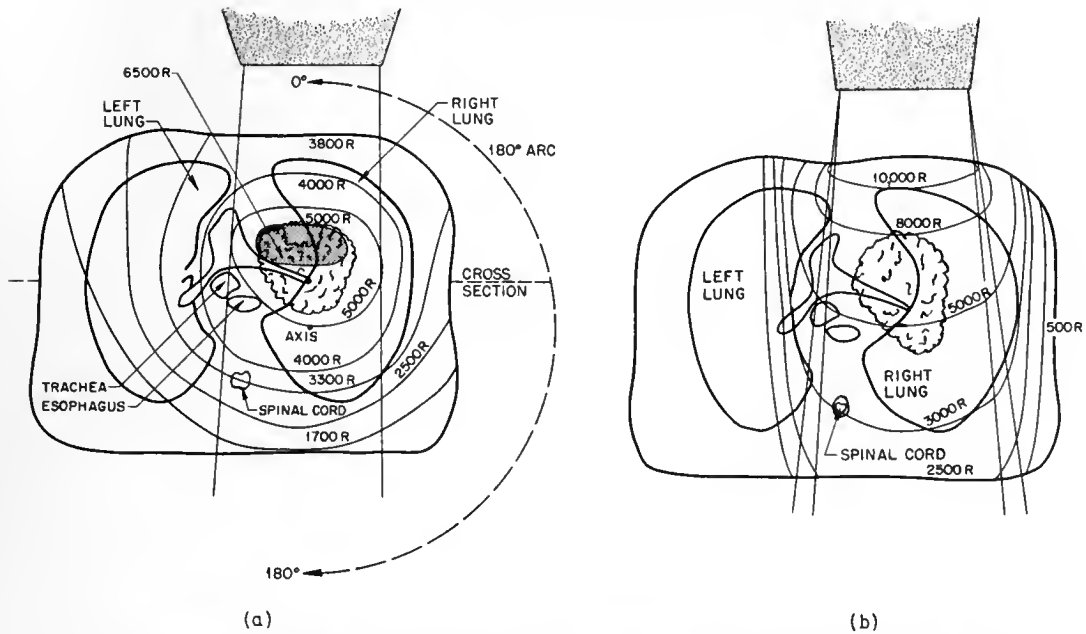

Fig. 11—Diagram of dosage distribution when carcinoma of the lung is treated (a) by cobalt rotation therapy through 180-deg arc (treatment is given laterally on the side of the lesion) and (b) by cobalt therapy given through a single stationary portal.



Fig. 12—Patient set up for cobalt rotation therapy through an anterior field for carcinoma of the bladder.

rotation therapy, as compared with similar complications noted after either stationary-field technique or stationary cross-fire technique. Toward the end of the course of rotation therapy, some patients had diarrhea resulting from radiation reaction in the

bowel. This usually subsided within a few weeks after treatment and was controllable by proper medication.

When carcinoma of the prostate was originally treated by the stationary cobalt technique, we found that severe skin reactions developed over the inter-

gluteal fold and buttocks as we approached a tumor dose of 5000 r in about six to eight weeks. These severe skin reactions usually lasted for several months and finally healed with residual atrophy of the skin and subcutaneous tissues as well as telangiect-

the complete course of therapy. One patient who had similar treatment given through a single stationary portal developed a posttherapy radiation necrosis of the bowel about four months after the completion of treatment. This was resected surgically, and a satis-

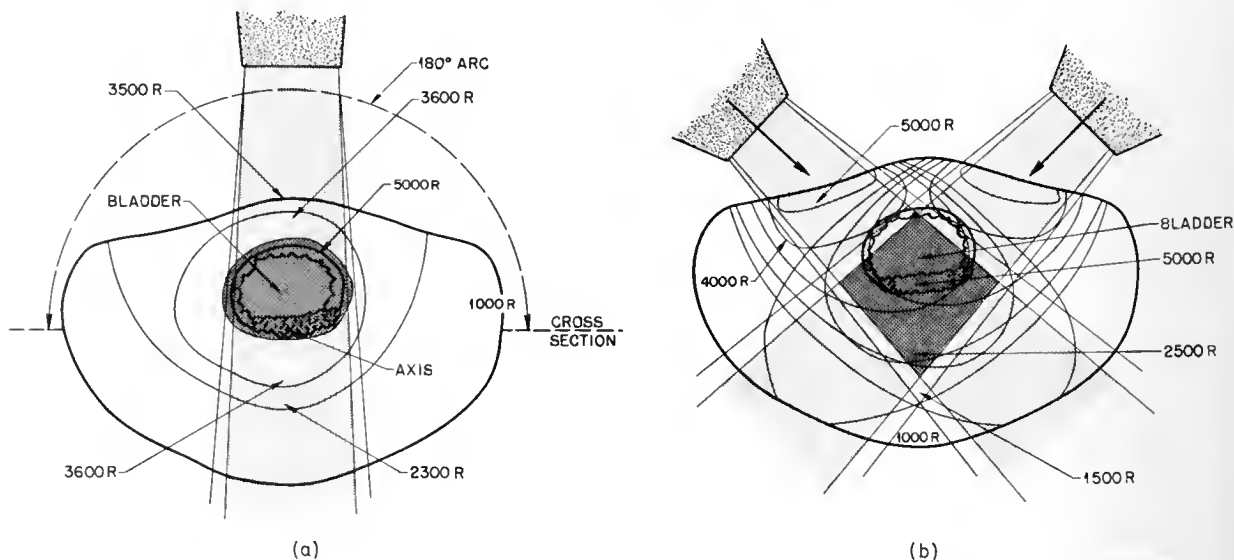

Fig. 13—Diagram showing the distribution of radiation dosage when carcinoma of the bladder is treated (a) through a 180-deg anterior arc and (b) by the cross-fire technique using two oblique anterior portals.

tasis of the skin. We also found that rectal reactions were extremely severe and painful and that the patient often complained of bloody diarrhea, which took several months to subside. Since changing our technique to a combination of stationary and rotation therapy, there has been only erythema and tanning of the skin and no atrophy or necrosis of the subcutaneous fat. We are now treating some of these patients by a single stationary perineal portal for a tumor dose of 2500 r, followed by rotation therapy to a total tumor dose of 5000 r in six to eight weeks.

Carcinoma of the Cervix, Uterus, and Ovary

Rotation cobalt teletherapy through an anterior 180-deg arc is used for carcinoma of the cervix, uterus, and ovary.

When this type rotation therapy is employed, the tumor dose of 5000 r is approached in about six to eight weeks. There is only slight tanning of the skin and no evidence of skin or subcutaneous tissue necrosis or atrophy. There usually is diarrhea as a result of some radiation reaction toward the end of

factory end-to-end anastomosis of the sigmoid colon was performed. No evidence of carcinoma was found in the removed specimen. A rather severe degree of bladder postirradiation edema and hemorrhage developed in the same patient. We have not seen any similar severe reactions when treatment was given by rotation therapy.

Many patients with carcinoma of the ovary have been treated primarily for the purpose of palliation. The lower half and the upper half of the abdomen were treated in separate series by rotation therapy. A tumor dose of 3000 to 5000 r was given to each half of the abdomen, depending on the condition of the patient and the stage of the disease. [We have recently published our plan of treatment for these patients in *Am. J. Obstets. Gynecol.*, 9: 111 (February 1957). It is interesting to note that when we treated the upper half of the abdomen the patients rarely complained of radiation sickness. When they did, we limited the daily tumor dose to about 100 to 130 r and gave Bonadoxin medication 30 min before each meal. When the daily tumor doses were increased to about 200 r with large fields, these patients were more likely to develop radiation sickness and diarrhea.

DISCUSSION

CHAPTER 30

Kerman: The upsurge of interest in moving-field therapy has paralleled the interest in supervoltage therapy. Neither technique is new, and theoretical considerations, as well as clinical applications, of moving-beam therapy were reported as early as 1906.

Radiotherapists and others have suggested rotation of either the beam or the patient as a logical extension of the multiple-port technique to achieve a suitable depth dose in an effort to spare the skin and intervening tissue in a deep-seated tumor. A variety of movements are possible. With a fixed beam one can rotate the patient in either the vertical or horizontal axis, or one could rotate the machine, with the patient in a fixed position in either the horizontal or vertical axis. In addition, partial movements resulting in arc or pendulum patterns could be achieved; finally, a spiral movement of the beam could also be used to produce a convergent pattern. The ultimate, perhaps, is Dr. Brucer's frightening cesium machine in which it is allegedly possible to move both patient and machine simultaneously in any conceivable manner.

The limitations of conventional X-ray units are immediately obvious. However, certain of the manufacturers, notably those abroad, have designed equipment that can be successfully used in this manner. Gamma-beam units, of course, are eminently suitable to be moved, and undoubtedly recent interest in both supervoltage and moving-field therapy is a direct result of the availability of certain of the gamma-ray emitting isotopes.

Freid: The sessions on rotation therapy covered every phase of this subject; therefore I believe my discussion is expendable. However, some points can be repeated for emphasis.

Rotation therapy is accurate and practical. It is applicable to a number of lesions, principally those situated in the thorax and pelvis. It permits large doses to the tumor, with the dose falling off sharply outside the tumor itself; therefore damage to the normal tissues is limited. By lowering the integral dose, one can spare the hemopoietic system.

At Montefiore Hospital the arrangement for rotation therapy is similar to Dr. Jaffe's arrangement. We do vertical rotation. However, we prefer casts for the areas that are to be irradiated for better localization of the lesions. We have not encountered severe skin reactions even when large doses have been delivered to the tumor.

We treat only about 20 per cent of our patients with rotation. For the others the distribution of the radiation is, in general, no better than that for multiple fixed ports. The high depth dose from Co^{60} makes rotation important for this modality as compared to 200-kv therapy.

Dr. Ellis states 3000 r as a critical dose for patients with pulmonary carcinoma. I believe this dose is too low for most cases. Our critical dose is much higher, closer to 4000 r. Brain tumors are rarely treated with rotation. It is often difficult to determine the extent of the primary tumors; therefore they are better managed with large portals. Metastatic lesions are also better treated with large fields.

The distribution of the irradiation for the breast cases presented by Dr. Jaffe looks good for the axilla and the anterior chest wall, and I suppose also for the internal mammary chain. We prefer to treat these cases with two tangential fields which include the internal mammary chain and lower axilla and a third field which includes the supra and infraclavicular areas and the axilla.

Most of our bladder cases have extensive disease and are treated with fields 10 by 10 cm and larger. For fields of this size, even with rotation, the volume of tissue irradiated is so large that the patients suffer severe reactions. In some cases the irradiation had to be discontinued at a dose level of about 4000 r, although the dose aimed at is much higher.

I do not see any advantage in rotation for fields of the size presented by Dr. Jaffe. I think that two or three portals are really better for that type of case than tangential irradiation.

I also noticed a cross-firing technique on one patient in Dr. Jaffe's group. I believe cross-fire techniques

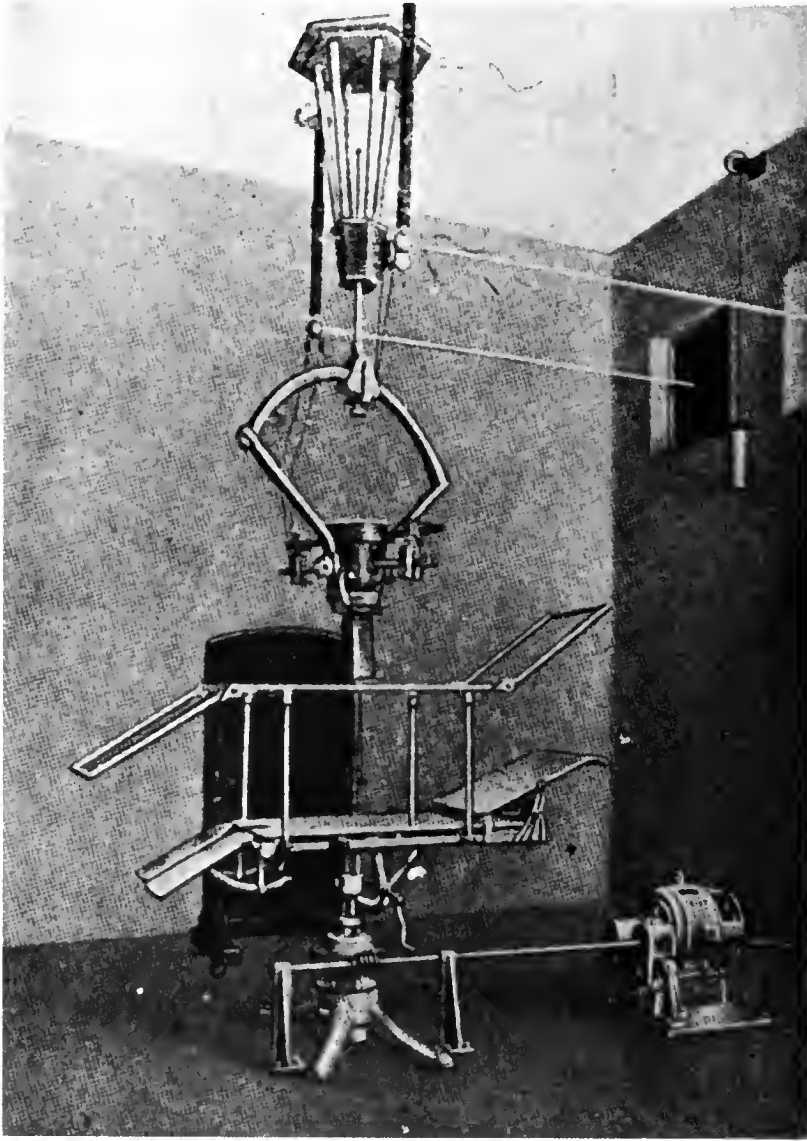

Fig. 1—Rotation therapy with an X-ray tube as described by Hirsch and Holzkecht in 1925.

are extremely dangerous for supervoltage irradiation. The depth dosage is sufficiently high with Co^{60} that cross-fire techniques are unnecessary. A lesion can be cross-fired from anterior, posterior, and lateral portals but not cross-fired from two adjacent anterior portals. It is very difficult, with radiation given in this manner, to calculate the dose that the bowel or adjacent tissues receive.

Tice: When Dr. Brucer asked me to take part in this discussion, I had the same excuse that some others have had: I was entirely ignorant of the subject and I had never seen cobalt or rotation therapy in operation. Dr. Brucer told me to talk anyway, so here I am.

The principle of rotation is not new. As Dr. Hunt indicated this morning, Knox developed a rotation-therapy machine in 1906, about 10 or 11 years after X ray was discovered by Roentgen.

As a young radiologist in 1930, in searching for information on my specialty, I ran across a book, "Principle and Practices of Roentgen Therapy," by Seth Hirsch, M.D., and Guido Holzkecht, M.D., published by the American X-ray Publishing Company in 1925. I was impressed among other things by a description of rotation therapy. Apparently the principle was not well accepted because through the years I heard no more about it until recently.

In looking over this article, I found that the principle of the revolving table and revolving tube holders was thoroughly discussed. This statement was made: "Knox and his colleagues described an apparatus which by rotating the energized tube gives the advantage of accuracy of the radiation at a localized point, and the administration of a large dose in the depth with a minimum dose upon the skin."

DISCUSSION

In this article the possibility of error due to inaccurate positioning of the angle at which the tube delivers radiation is discussed. Also an attempt was made, even though the roentgen had not yet been defined, to arrive at a relation between depth dose and air dose.

I have spent a little over 25 years in the practice of radiology using so-called "conventional techniques." It would be somewhat of a venture for me to adopt supervoltage irradiation and the principle of rotation therapy simultaneously. Such a change-over in my way

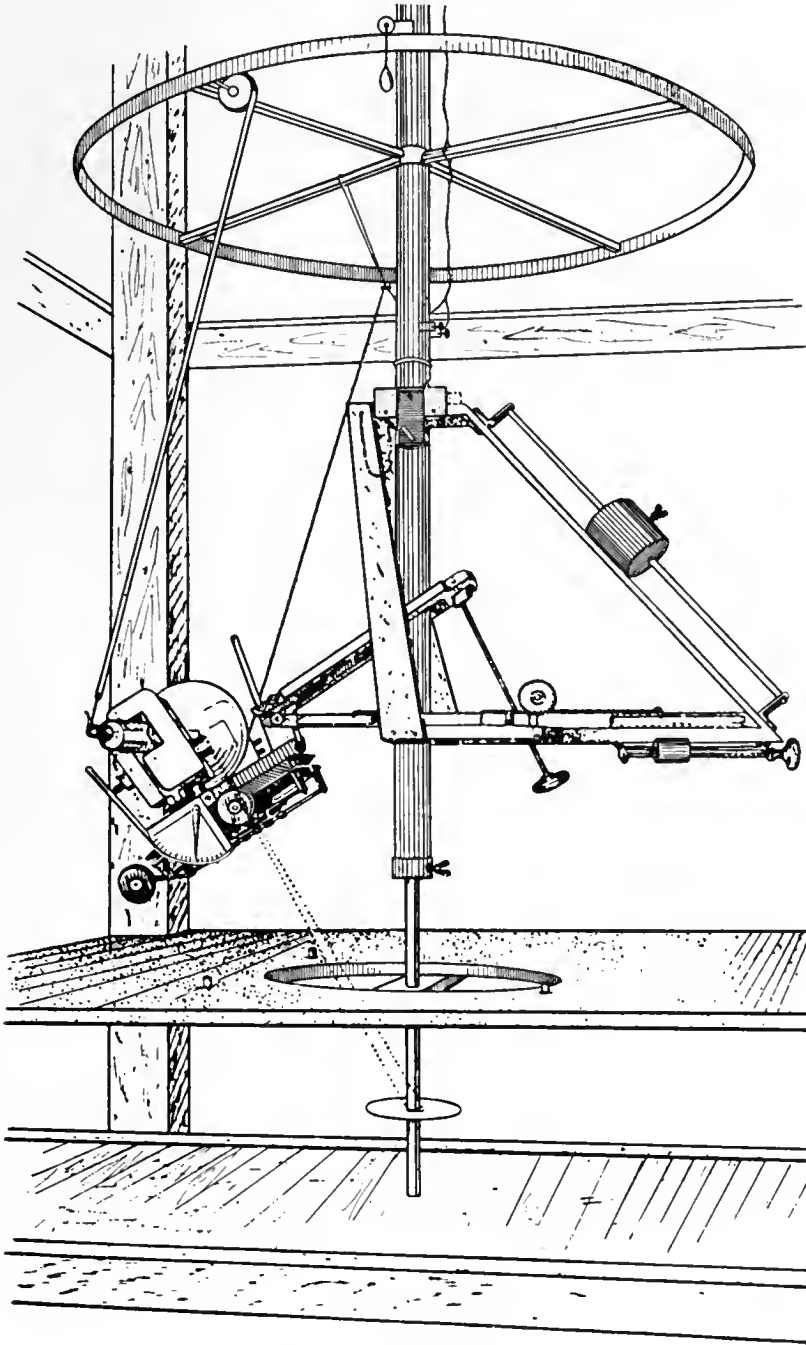

Fig. 2—Rotating table (Knox).

Figure 1 is Knox's conception of rotation therapy with an X-ray tube as described by Hirsch and Holz-knecht in 1925. Figure 2 illustrates the rotating table of Knox.

of doing therapy would have to have some important things in its favor. I would expect more cures and better control of cancer.

At the University of Kansas Medical Center, a yearly

postgraduate program is held for radiologists. I have invited as our guests radiologists who have had experience with supervoltage. We have had Dr. Cantril, Dr. Carpender, and Dr. Jacox. We have had Dr. Brucer, who has shown a great interest in the supervoltage problem. Each year I hoped that one of these men would tell us that with supervoltage we can get possibly 10 per cent more cures of cancer of the cervix or 15 per cent more cures of lymphosarcoma. This information has not yet been published, and I have not heard similar promises at this meeting.

I am a reasonably good therapist with standard techniques. I am sure that all of you feel the same about your efforts. We all have hopeless cancer cases treated many years ago with conventional therapy who are living and apparently cured of cancer. Last week in our follow-up clinic I saw two patients who perhaps have no statistical right to be living: a case of Hodgkin's disease treated 20 years ago and a case of carcinoma of the cervix (stage II) treated 10 years ago. Our conventional therapy, as employed hitherto, is not entirely inefficient.

The oft-stated feature of supervoltage that less skin reaction will develop does not interest me very much. All of you have used enough radiation to make the skin peel off down to the blood-red oozing corium, and you did not feel too bad about this reaction. The patient was somewhat uncomfortable for a while but not nearly so uncomfortable as he would have been had you not controlled his cancer. It was surprising how rapidly the new skin formed.

If these patients can be treated without this reaction with just as good final result, that is fine for the patient. I wonder if one is justified in erecting a building and installing a cobalt unit at considerable cost to overcome this particular handicap.

Opinions among the experts have differed concerning the effect of supervoltage radiation. The same difference of opinion exists about the degree of systemic reaction with supervoltage.

The discussion on re-treatment has impressed me. My reaction to a case of postirradiation recurrence is to take the patient to a surgeon for evisceration. If this is not advisable, then I may re-treat him; sometimes I get into trouble by the procedure. If that trouble can be avoided by using supervoltage rotation therapy, it would certainly be of value.

I have been disturbed by the possibility of error in depth-dose determination when rotation is employed. Not all have physicists. With a fixed-portal technique the average radiologist and his residents can calculate dosage and get by. I would not attempt dose estimation at present without a physicist to help me with rotation therapy.

I do not want to be considered a pessimist. Actually, we have on order a cobalt unit capable of rotation. I am sure that when it is installed I shall do the same as my colleagues have done. I shall experiment with rotation and try to determine its efficiency as compared with fixed-beam procedures.

Farmer: I should like to speak quite briefly on rotation therapy. If one accepts as a general principle that radiation given outside the tumor is undesirable, then rotation therapy is against us. There is, of course, a saving in skin dose. There is also a gain in the symmetrical character of the dose contours; so on paper at least the radiation appears to be better trimmed around the tumor. However, the total amount of radiation—the integral dose to the body—will in general be greater than that for fixed fields. The reason is that in rotation therapy, instead of having all the radiation applied through a few well-chosen ports of entry, some of it is given in relatively unfavorable directions in which the percentage depth dose is low. And so, as a general rule, the integral dose must necessarily be greater.

I was frankly puzzled by the results given by Dr. Jaffe, which showed in many cases a smaller integral dose for rotation than for fixed fields, and I would like to understand just how this is achieved. If the field sizes are chosen to give the same margin of safety around the tumor, then I cannot see why the integral dose should be less with rotation.

Now, let me say just a word or two about 250-kv rotation therapy. We have studied in Newcastle somewhat critically the dosage distribution for a number of tumor sites, first using fixed fields and then rotation for the same anatomical conditions. We did this because we are embarking on a program of rotation therapy at this kilovoltage and wanted, before starting, to judge what types of case were likely to do best. As Dr. Ellis has already said, a number of factors have to be chosen very carefully if one is going to achieve any advantage, and it cannot just be assumed that rotation is preferable to fixed fields unless these are taken fully into account. Our own conclusion from this study is that unless you use a hard filtered radiation [about 2.5 to 3 mm of copper, half-value layer (HVL)], unless you choose the center of rotation extremely carefully (and indeed use different centers in general for the anterior and posterior arcs), and unless you put a flattening filter into the beam to reduce the dose at the center more than at the edges, it is very difficult to make any strong case at all for rotation therapy at 250 kv.

If you do these things, there seem to be real advantages, and this type of therapy undoubtedly has its applications. The case falls down completely when you are dealing with large tumors, such as those filling the whole pelvis. It is essentially a small-tumor technique.

Perhaps I might conclude with a few words about rotation at Co^{60} energies, referring in particular to the question of penumbra. The possibility of rotating the source around the patient is very attractive and is being put to good use in the many elegant machines now available. However, I think we have to ask ourselves, "What is the price we pay in using rotation as compared with fixed fields?" I would like to mention the pros and cons as they appear to me.

If you are using fixed fields, then having decided on your source-to-skin distance (SSD), e.g., 40 cm, you will place the diaphragms as near the skin as possible

to minimize penumbra at the edges of the field. A gap of 10 to 12 cm is normally sufficient for build-up.

If you now decide to rotate the source around the tumor, you will immediately have to increase the SSD to clear the patient, especially where eccentric tumors are involved. This normally results in a radius of rota-

This penumbra problem becomes very much more important for Cs^{137} , where the size of source for a given gamma-ray output is many times greater than that for cobalt. My own view is that it is very unlikely that rotation of cesium will find any lasting place in telecurie therapy.

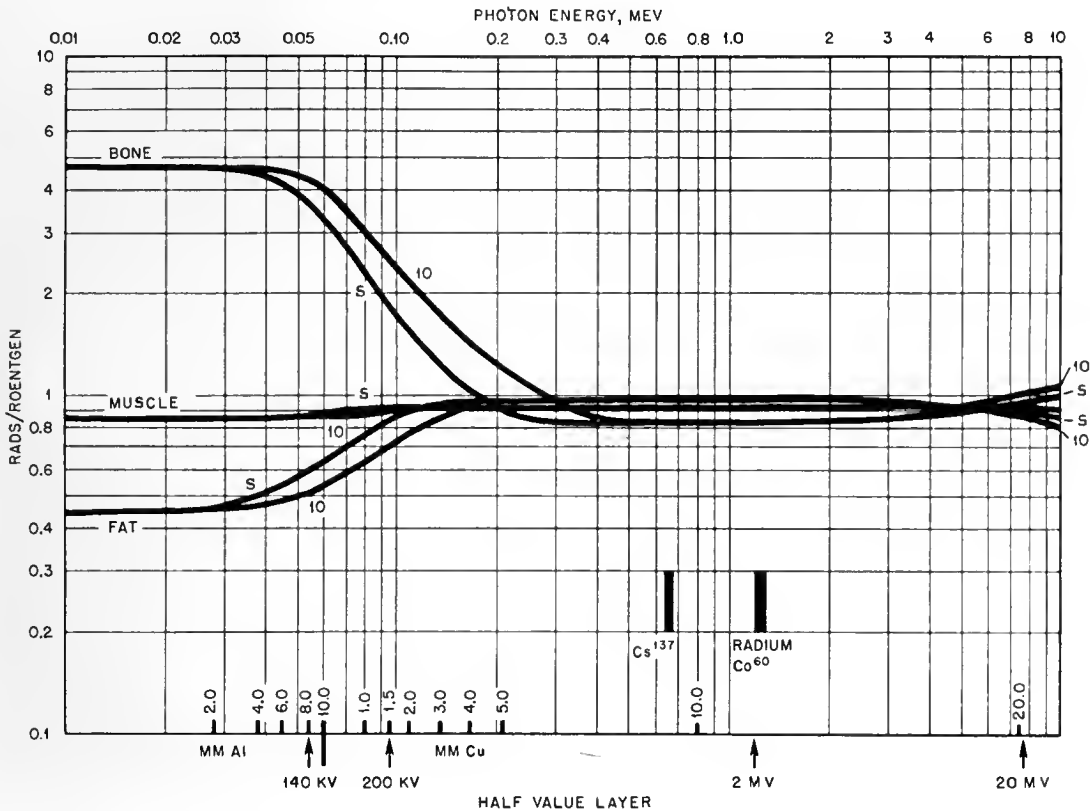

Fig. 3—Variation in absorption in bone, muscle, and fat with quality of radiation, shown in relation to the surface and 10 cm depth for X rays of varying HVL and for radium, Cs^{137} , and Co^{60} . (Modification of a diagram of Professor F. W. Spiers.)

tion of about 70 cm, the diaphragms remaining at their original distance from the source, i.e., about 30 cm. Consequently the penumbra width is increased on two counts: first, because you will need to use a larger source to get the same dose rate to the tumor and, second, because the diaphragms will be, on the average, considerably farther from the skin. The result will be an increase in integral dose to the rest of the body for a given dose to the tumor, and this may even outweigh the advantages of rotation over fixed fields.

Whether this integral dose matters may be questioned; Dr. Ellis has given some extremely interesting ideas on this point. It may be that it does not matter. But, if, as is generally supposed, radiation outside the tumor is harmful, then I think one should always remember that the price of rotation is some increase in this integral dose. The fact that with Co^{60} the skin reaction is practically nil seems to me to make the case for rotation at these energies less than is commonly supposed.

Ellis: I think I must have given Dr. Freid a wrong impression. Let us assume a carcinoma of the lung in a chest. I would not say that the dose should not exceed 2500 r. I only say that, in giving 4000 r, you should not risk giving 2500 r to the rest of the lung unless you could not help it. Furthermore, for a cobalt beam, that dose could probably be raised to 3000 r because of the diminished relative biological efficiency.

Smithers: One thing I wish to try to define for you is the poor man's supravoltage. Figure 3 is the graph commonly presented; it shows the differential absorption in bone, muscle, and fat. It has one or two minor differences from the ones physicists usually put up for us. Their photon energies are on the top scale. The factors the radiotherapists are used to are put along the bottom scale. The lines marked 10 are the distortions of these curves at a depth of 10 cm. Generally speaking, if you use soft radiation, as it penetrates

it gets harder. So these differential bone absorptions are distorted at depth. The poor man's supervoltage begins at about 4 to 5 mm of copper HVL.

The 200-kv X rays are poor for deep therapy. We try to improve them with extra filtration up to 3 mm of copper HVL. They are just beginning to get into the better region. After hearing the previous speakers, I

the increased thickness laterally and still further by the spine. The difficulty with the sword swallower, who was not used to anything as thick as this scintillation counter probe in his esophagus, was to keep him still; he had to heave a little. He said the probe did not have quite as nice a polish as the swords he was used to.



Fig. 4—Continuously reading dose-rate scintillation counter recording dose rate in esophagus during rotation therapy (professional sword swallower).

thought that a great deal of hard work was being done by physicists, in working out rotation distributions for soft radiation, which means very little when they are done. The same amount of hard work applied to rotation therapy in a region of beam quality unaffected by differential bone distortion is extremely useful. Cesium comes in very nicely here; it seems to be one obvious answer to much of our problem of the poor man's supervoltage.

We measured the dose rate in the middle of the chest during rotation by getting a professional sword swallower to take a scintillation counter and pop it down into his esophagus (Fig. 4). He was rotated in the beam, and the dose rate was read continuously in the esophagus as he went around. This was plotted on a polar diagram (Fig. 5). The dose rate at the center is plotted in the direction from which the beam is coming. The unbroken line indicates the dose rate at the middle, in which we are interested, but it also indicates how it varies as the beam reaches it from different directions. Through the front of the chest there is an increase in dose rate at the esophagus. This is later reduced by

We then built a phantom; the phantom was not so good as the human being, but we could compare it with the living area. The phantom is made with bones impregnated with wax and lung spaces filled with sawdust. The whole is placed in a perspex cast of the patient, and the cast is filled with bolus. When this is done and rotation at 200 kv is utilized, you can see the distortions that occur (Fig. 6). If the voltage is increased to 2 Mv, you see that you are beginning to get something much nearer a circle (Fig. 7), indicating a fairly uniform esophagus dose rate from all directions; and, if the voltage is increased to 24 Mv, you can see an even dose rate throughout (Fig. 8).

I think it is important to realize that there is a great deal of fuss in calculating the dose at a depth at low voltages and that it is a real waste of time.

I should very much like to say one or two other things. Dr. Guttman's paper was extremely interesting and showed a delightful blend of scientific accuracy with thought for individual people being treated. I should very much like to know if any analysis has been done of these esophagus patients who were first irradiated

and then operated on to show which types of tumor responded and which types did not. This seems to me to need a careful analysis, and it might be of very great interest.

locating the beam and fixing the patient, is like using a sledge hammer to crack a nut. If you want to destroy the pituitary, the way to do it with radiation is by radioactive implant through the nose. It is not difficult

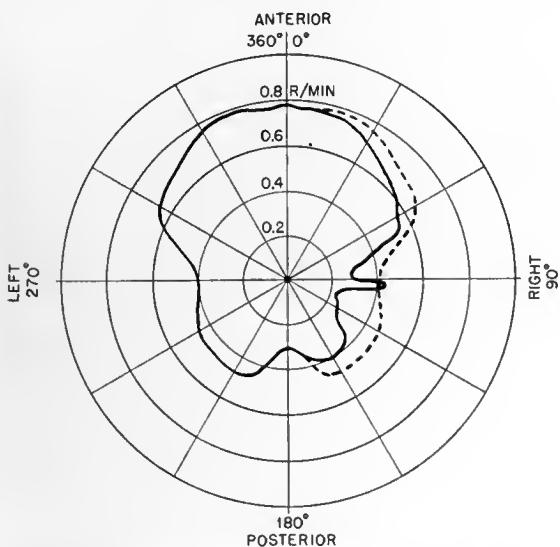

Fig. 5—Polar diagram to show variation of dose rate in esophagus of sword swallower rotated in a beam of 400-kv X rays; 3.5 mm of copper HVL. —, measured; ----, corrected for patient's heaving.

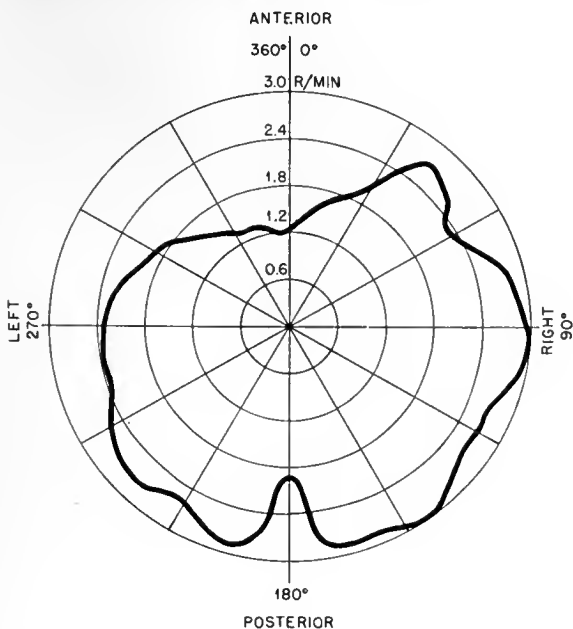

Fig. 6—Polar diagram to show variation of dose rate in esophagus of phantom rotated in a beam of 220-kv X rays. Target-to-axis distance, 70 cm; axial field, 4 cm in diameter; 10 r/min in air at the axis.

I should also like to say that surely this is not the way to try to destroy the pituitary. Really, to give 30,000 r on a small field, with all this difficulty in

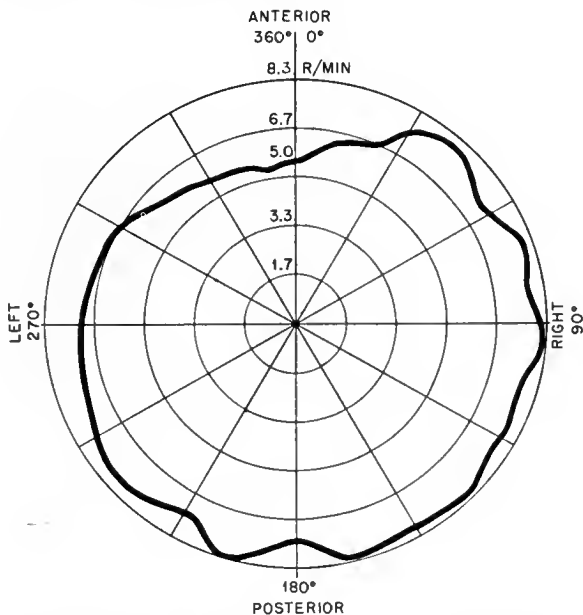

Fig. 7—Polar diagram to show variation of dose rate in esophagus of phantom rotated in a beam of 2-Mv X rays. Target-to-axis distance, 67 cm; axial field, 4 cm in diameter; 10 r/min in air at the axis.

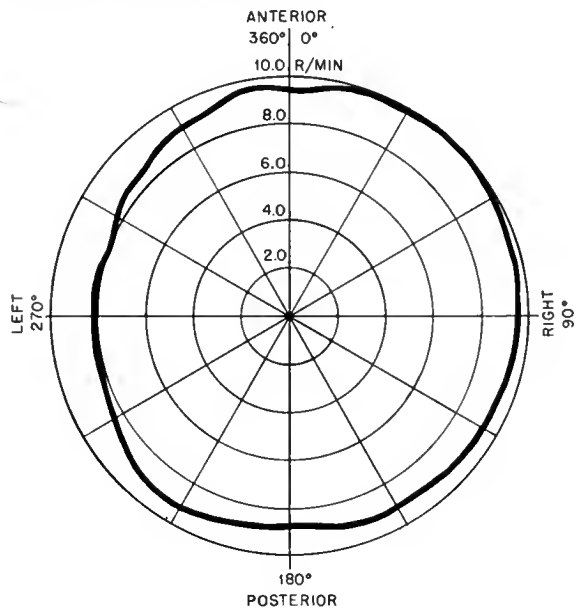

Fig. 8—Polar diagram to show variation of dose rate in esophagus of phantom rotated in a beam of 24-Mv X rays. Target-to-axis distance, 100 cm; axial field, 6 cm in diameter; 10 r/min in air at the axis.

to do with an adequate beta-ray emitter and can be done with practically no risk.

Lastly, I again agree with Dr. Guttman that we need to retain some dignity in our treatment. I think that having the patients stripped to the waist, with their lax abdomens held up in the air with webbing bands, standing in the middle of treatment rooms, turning around, half naked, in front of the radiation sources is a bit too much.



Fig. 9—Epithelitis on the tongue of a patient with a tumor of the hard palate. Treatment was with 2-Mv X rays.

I also sympathize with the poor patients who hold their hands above their heads as they turn; they must either turn around fast enough to be able to keep their arms up and thus become dizzy or turn more slowly and cause their arms to ache. Anyone who has ever tried to repair a ceiling light knows how difficult it is to keep your arms above your head for any length of time.

Friedman: Dr. Guttman's presentation is significant because she is in a position to compare a 2-Mv X-ray machine with a Theratron. The eventual results of the comparison may help many to decide which supervoltage radiation apparatus to purchase. Dr. Guttman has stated: "Rotation with supervoltage is a convenience, but I do not think it is ever an absolute necessity." The probable reason for this conclusion is that she has the Theratron, which is convenient for the patient but not efficient for proper dose distribution in tissue. I shall explain this presently.

Dr. Smithers had to reach into left field—or its cricket equivalent—to bolster hollow-cone rotation and to attack rotation with the patient vertical with specious arguments that are basically not very strong.

I shall illustrate these points with two figures. Figure 9 depicts the tongue of a patient who had a tumor of the hard palate and floor of the nose; it was irradiated with 2 million volt X rays by means of the rotation technique. The predetermined diameter of the rotation field was 5 cm. Those of you who have measured tongues can appreciate that the diameter of this sharply circumscribed second-degree epithelitis reaction is 5 cm. This demonstration of epithelitis which

is sharply localized to the cylinder of high-intensity irradiation is critically important. A true test of the efficiency of a rotation technique is the production of a sharply localized epithelitis of predetermined size and in a predetermined location. To my knowledge this has not yet been achieved with a commercial cobalt machine.

Figure 10 illustrates a similar achievement but in a deeply situated chordoma of a lumbar vertebra adjacent to the vulnerable spinal cord. At the edge of the tumor, the isodose curve delineates the 95 per cent dose; at the nearest part of the spinal cord, 1 cm away, the dose has fallen off to 60 per cent. Thus we were able to deliver a large dose of 7200 r to the tumor, and the fall-off was so rapid that the spinal cord received safe doses ranging from 3800 to 4400 r. The tumor has been arrested for four and one-half years. There are no complications. This rapid fall-off from the maximum is highly desirable if one wishes to irradiate safely deep-seated tumors requiring large doses.

Dr. Guttman illustrated comparable isodose curves obtained when treating a carcinoma of the esophagus with a rotating cobalt machine (the Theratron). Because of the broad penumbra, the fall-off from the high dose volume is so slow that 6 cm from the esophagus the dose is still 75 per cent of that at the axis of rotation. The integral dose is enormous, and the tissue dose to the adjacent lungs is so high as to limit the total tumor dose that can be given. Compare this with our 2-Mv resonant-transformer generator, where the tissue dose 6 cm from the axis is 25 per cent of the maximum instead of 75 per cent. The reason is that the high roentgen flux allows us to treat at 125-cm target-to-axis distance, and within that additional space an efficient collimator can be inserted to minimize the penumbra. Rotating cobalt machines will have to be constructed with a greater target-to-axis distance, probably 95 cm, and with more efficient collimation. The consequent low roentgen flux will materially increase the cost of irradiation.

This morning, I suggested that the index of efficiency for a supervoltage rotation technique could be expressed as the distance from the 90 per cent isodose curve to the 50 per cent isodose curve. With our 2 million volt resonant-transformer generator, you can see that this distance is about 2 cm. With the Theratron it is 6 to 8 cm; this means that not only the integral dose but also the tissue dose to adjacent normal tissues will be very high. The latter inefficiency is due to the fact that the short target-to-axis distance prevents good collimation. The resultant wide penumbra prevents a sharply localized high dose volume.

It is my impression that the Theratron, because of the numerous compromises, falls short of an ideal supervoltage apparatus. It nullifies the one specific advantage that supervoltage rotation has to offer (and it is an important one): the ability to deliver a large concentrated dose to the tumor while at the same time delivering a relatively low dose to the surrounding normal tissue. This can be easily resolved by increasing the target-to-axis distance to 90 or 100 cm and

improving the collimation. To compensate for the reduced rhm, a source with a higher specific activity will be required. This in turn necessitates more lead in the tube head or else a head made of uranium or gold.

I would like to save the physicists a great deal of unnecessary work by suggesting that they cease to calculate integral dose. The reason for this was illustrated by Dr. Clark's demonstration that, in the irradiation of a pituitary gland, the integral dose with two opposing portals was approximately the same as that with 360-deg rotation, implying that there was no difference between the two techniques. Actually with 360-deg rotation, the impact on the patient is much greater than if two opposing portals are used because a larger amount of the hemopoietic system in the flat bones of the skull is irradiated. This anatomical feature cannot be included in the equation for integral dose; yet integral dose is supposed to symbolize the impact of the irradiation on the whole body, most particularly the hemopoietic system. Integral dose bears little relation to the irradiation of a cancerous lesion. The statement of an integral dose needs additional qualification: one must know where the irradiated volume is situated.

Many of you must have seen the play or the movie "Annie Get Your Gun," in which the heroine sang "Anything You Can Do I Can Do Better." This is one of my favorite songs and my favorite premise in evaluating supervoltage irradiation. (By the way, she lost her man by singing that song.) I should like to voice the reciprocal of that song, and this may surprise you a bit: "Any circumscribed lesion that you can irradiate with supervoltage, you can do better with interstitial irradiation."

An attempt to deliver a concentrated volume of radiation to any part of the body with supervoltage X rays is a formidable one; not that it is difficult to execute, but the impact on the patient is formidable. The patient can tolerate accurate interstitial irradiation much better.

It is a different story when irradiating a locally extensive lesion or one with metastases, especially when the nodes as well as the primary tumor must be irradiated. However, if we are irradiating a circumscribed lesion, it can be done more easily, with greater comfort to the patient, with a smaller tumor dose, and with a smaller integral dose by means of interstitial

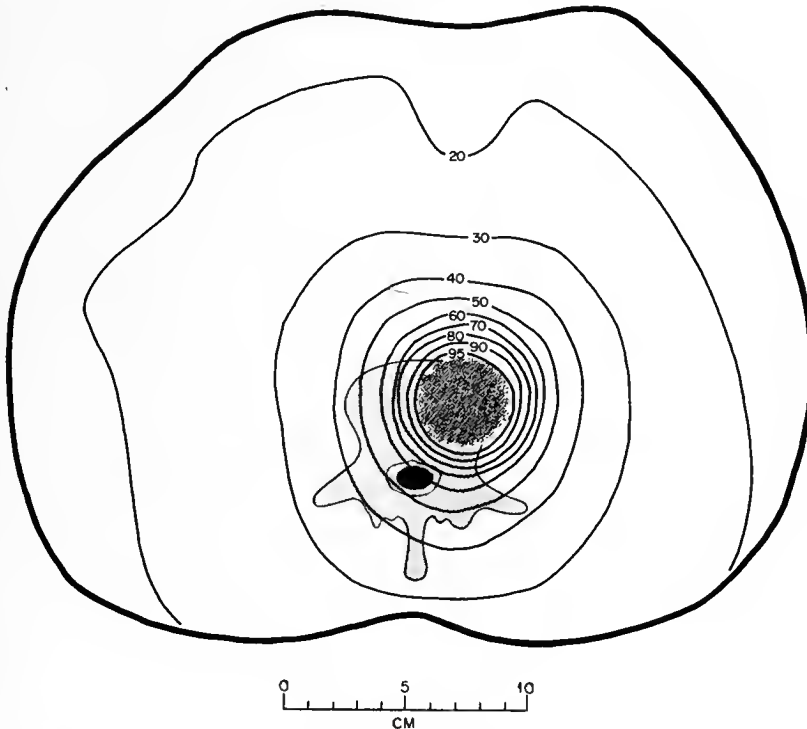

Fig. 10—Isodose lines around a chordoma of a lumbar vertebra. Dose to tumor, 7200 r; dose to spinal cord, 3800 to 4400 r.

To give another example: an integral dose from "patient-vertical" rotation at the umbilicus level encompasses a small part of the hemopoietic system in the spinal column. This irradiation dose exerts a smaller effect on the blood-forming centers than the same quantitative integral dose around the chest or the pelvis, which includes much more bone marrow.

I am eagerly anticipating Dr. Ellis's presentation on the advanced techniques of interstitial irradiation with various brachytherapy devices. He is pioneering in an important field.

Next, I should like to organize a conspiracy, a revolutionary conspiracy whereby, without violence, we can inter 6000 rads as a cancericidal dose; we have heard

a great deal about it during this meeting, but it really is not a very effective dose against many cancers.

I should like to redraw the curve (Fig. 11) which Dr. Tubiana drew, showing percentage of cures increasing at first with dosage and then decreasing because the increasing doses introduce complications that defeat the attempt at cure.

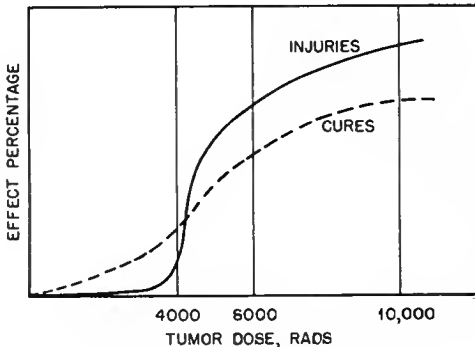

Fig. 11—Graph showing a correlation between the number of cures and the number of injuries produced by irradiation as the tumor dose increases.

In the dose ranges up to the level of 4000 rads, which is not very high, lie the radiosensitive tumors against which we have accomplished a great deal with "conventional" radium and 250-kv X-ray therapy. By perfecting our own techniques and giving more time and thought to each patient, we can improve the arrest rates.

In the succeeding group of more radioresistant lesions lies a region warranting further exploration. Dr. Guttman mentioned two carcinomas of the esophagus, one that was arrested with 6000 r and one that was not cured with 6000 r, and she asked for an explanation. I cannot explain it, but I can define the general problem. Squamous-cell carcinoma has a tumor lethal dose that will range from 4000 rads in three to four weeks up to more than 12,000 rads. We have seen squamous-cell carcinoma persist in spite of a dose as high as 12,000 rads. Locally recurrent or residual carcinoma in the cervix is a common example of radioresistant squamous-cell carcinoma. Thus every type of tumor, including cancer of the esophagus, has a broad spectrum of tumor lethal doses. Applying the same dose to all tumors of each type is an incorrect concept.

One of the next important avenues for exploration is the character of this spectrum. How can we ascertain early in the course of irradiation whether a tumor

will require a larger or smaller dose than the average dose for each group? The modality and the type of treatment to be selected will vary enormously, depending upon the dose required to destroy a particular tumor.

Probably everyone in this room has seen an advanced stage III or even stage IV carcinoma of the cervix disappear unexpectedly and the patient remain well for many years. These exquisitely radiosensitive carcinomas of the cervix are not rare. They constitute a definite percentage of cervix cancers. It is probable that 20 per cent of cervix cancers can be destroyed with tumor doses between 4000 and 5000 rads in four weeks. We are not going to irradiate that type of tumor with the same modality and dosage as a tumor that will recur or persist in spite of doses larger than 10,000 rads.

The same is true for carcinoma of the bladder. The spectrum of tumor lethal dose for cancer of the bladder ranges from 5000 to 10,000 rads or more in five to eight weeks. I have a number with persistent—not recurrent, persistent—disease at the end of treatment with doses of 10,000 rads delivered with supervoltage rotation therapy. There should be a vast difference in the type of treatment for a radiosensitive carcinoma of the bladder and a radioresistant one.

Parenthetically, I should like to sing an encore of the aforesung song with respect to cancer of the bladder. Based on my experience, I think that we shall arrest many more carcinomas of the bladder with local irradiation techniques, either proper interstitial irradiation or a small central source in a balloon (the Walter Reed technique), than we shall with supervoltage rotation irradiation. With supervoltage rotation irradiation the impact on the normal bladder is far greater than it is with a central source. The same is true for most tumors that we undertake to irradiate.

The literature and the atmosphere are filled with preliminary predictions, not only by physicists but by radiotherapists, about what can be expected from supervoltage irradiation. The only thing I can say is that the most consistent expectation from supervoltage irradiation is that we shall be surprised.

Paradoxes are numerous. For example, tomorrow I shall show you that supervoltage irradiation does not spare the skin; its effect on the skin may be worse than conventional irradiation under certain circumstances. There are a number of other paradoxes; thus we must be careful in drawing early conclusions on the basis of a few cases treated a short time ago. One must be hypercritical of all observations, and one must be particularly careful about delivering massive doses of supervoltage irradiation through one or two portals.

Section
G

Clinical Radiobiology

Robert J. Reeves
(presiding)

Normal Tissue Tolerance

CHAPTER 31

Milton Friedman

Hospital for Joint Diseases
New York, New York

My remarks will be divided into two main parts: (1) injuries produced by doses exceeding tolerance and (2) methods for circumventing the barrier of tissue intolerance.

Injuries Produced by Doses Exceeding Tolerance

Introduction

Much of my experience is based on a closed series of 232 carcinomas of the testis which I treated from May 1942 to December 1946 at Walter Reed Army Hospital. A standard technique was used; one-fifth of the patients were treated with 200-kv X rays and four-fifths with 1-Mv X rays.

In 1950, 104 living patients were brought back to the hospital for a period of 10 days and were submitted to a battery of 200 tests by a team of doctors which included:

Aubrey O. Hampton (deceased)
Milton Friedman, New York City
Lloyd G. Lewis, Washington, D. C.
Harold I. Amory, Beckley, W. Va.
Irving S. Brick, Washington, D. C.
William N. Thomas, Jr., Washington, D. C.
William M. Leavenworth, Jacksonville, Fla.
Ralph M. Caulk, Washington, D. C.

The purpose of the study was not only to evaluate the effect of the irradiation on the tumor and normal tissues but also to estimate the economic and social capability left in a man who had been battered with radical surgery and radiation therapy. Most cancer follow-up studies report uncritically that a patient is "alive and well" if he has no tumor. Actually many patients are "alive and not so well."

Therapeutic Problem

The therapeutic problem in tumors of the testis is the irradiation of the entire retroperitoneal chain of lymph

nodes from the external iliac ring to the diaphragm. At first the doses were empirical. After histological studies of radiation effects, it became evident that the average tumor lethal dose for seminoma was 1000 rads in 14 days. Some resistant seminomas required doses as large as 3000 rads in four weeks. The non-seminomatous tumors required doses from 4000 to 6000 rads in five to nine weeks.

Irradiation Technique

Most patients were irradiated with a two-portal cross-fire technique, the portals being 10 cm wide (Fig. 1). The nodes were approximately in the center of the abdomen. The dose was more or less the same for the skin, subcutaneous tissues, muscle, small intestine, transverse colon, stomach, retroperitoneal nodes, mesentery, kidney, spinal column, and spinal cord. This technique was apparently well tolerated by the patient, with minimal skin reactions. It ultimately proved to be the worst one we could have used because, when delivering tumor doses higher than 4000 rads, we were jeopardizing almost every normal structure traversed by the beam of radiation.

There is one technique still commonly used with supervoltage irradiation which is worse: delivery of the entire dose through a single portal. With supervoltage irradiation the percentage depth dose is high, but one must remember that all the intervening tissues receive larger amounts of irradiation than the tumor.

Skin and Subcutaneous Tissue

Let us first consider the skin. Supervoltage irradiation is supposed to spare the skin; but with certain doses it has a serious late effect on the skin. The patient shown in Fig. 2 had been irradiated with 200-kv X rays five years previously. The skin dose to each portal was 4000 r in seven weeks. Five years later we see, characteristic of 200-kv X rays, telangiectasis, superficial atrophy, and a slight amount of subcutaneous fibrosis. The greatest effect is ob-

served in the center of the area. Although the changes in the superficial layers are consequential, the subcutaneous and deeper effects are mild, and the total of all effects is still mild. On the other hand, with 1-

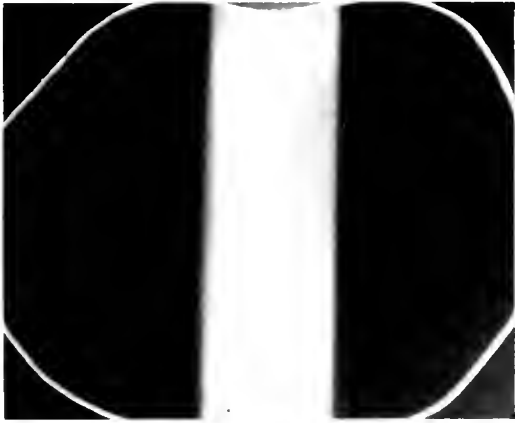

Fig. 1—Radiographic demonstration of a poor type of dose distribution, using supervoltage X rays from a resonant-transformer generator.



Fig. 2—Appearance of the skin five years after 4000 r (measured with back-scatter) from 200-kv X rays. The late effects are in the superficial layers.

Mv X rays the average skin dose of 5000 rads in six to nine weeks produced either no early reaction or a mild erythema. Thereafter, after a latent period of several months to two years, active subcutaneous fibrosis started. It then extended deeply to replace and immobilize muscle tissue and superficially to pull the skin into the fibrous mass. Not only would the vascular supply be disturbed and intensified but also the pigmentation of the skin. The abdominal wall (Fig.

3), as well as the perispinal tissues, would form a hard, fibrous, boardlike mass from 2 to 4 cm thick. Although the early effects of supervoltage X rays are mild, the later effects can be severe because of the depth of the biologic effect of the irradiation. Occasionally, when the position of a portal was eccentric, the resultant fibrosis would produce a slight curvature of the spine (Fig. 4).



Fig. 3—Appearance of the skin several years after a skin dose of 5000 rads in seven weeks with 1-Mv X rays.



Fig. 4—Scoliosis from contracture of radiation-induced fibrosis of perispinal muscles. The nonlinear alignment of the treatment portals resulted in curvature of the spine.

The incidence of late skin reactions varied considerably (Table 1).

Figure 5a, taken nine years after irradiation, illustrates the later consequences of these changes. Moving the hand down the abdominal wall, one can feel calcified nodules and can occasionally pick out tiny spicules of calcium. A lateral radiograph (Fig. 5b) of

Table 1—LATE SKIN REACTIONS*

Type of reaction	Skin dose, r
Mild	1500—5400
Moderate	3500—5900
Severe	5000—6000

*Five years after 1000-kv irradiation.



Fig. 5a—Skin of the abdomen nine years after 5000 r from 1-Mv X rays. The white spots in the pigmented area are pieces of calcium, some of which can be picked out.



Fig. 5b—Lateral radiograph of the abdominal wall. The mottled pattern of calcification in the rectus muscle and subcutaneous tissues is a manifestation of organ selectivity of late radiation effects. This type of calcification is suspected as being a precursor of osteogenic sarcoma.

this abdominal wall shows the irregular calcification within the subcutaneous and deep muscle tissues. Two possible explanations for this phenomenon are (1) progressive endarteritis obliterans with minute areas of focal necrosis and calcium deposition or (2) radiation-induced metaplasia of mesoderm into proliferating mesenchymal tissues. This calcification may be a precursor of radiation-induced osteogenic sarcoma.

Bone

The skin of the patient shown in Fig. 6a had received six months previously an incident skin dose of 4000 r in 70 days with 200-kv X radiation. The typical late pigmentation can be seen. Four and three-fourths years after irradiation, there was intracalcification and subcutaneous calcification of the tissues beneath the treatment portal in the region of the lower dorsal spine (Fig. 6b). Gradually calcified granulation tissue exfoliated out of the skin and bled. The biopsy specimen showed osteogenic sarcoma. The first radiograph of the lesion is poor (Fig. 6c), but it shows the subcutaneous location of the calcified mass. There is no doubt that this was a radiation-induced osteogenic sarcoma arising in the extraskeletal soft tissues. The lesion recurred despite several massive operations. Nine months later the bone-forming tumor had recurred locally, infiltrated the adjacent tissues extensively, and produced a bone-forming metastatic mass in the axillary node, which was readily identifiable on the radiograph (Fig. 6d).

Concerning the incidence of radiation-induced osteogenic sarcoma, in this series of 232 testis-tumor patients irradiated with skin doses of 4000 to 5000 rads, there were four cases of osteogenic sarcoma. This significant incidence further negates the contention that supervoltage irradiation has a bone-sparing effect.

In spite of the already published experience of the severe late effects of supervoltage irradiation on the skin and subcutaneous tissues, I know of more than 10 patients treated in different clinics in which the skin dose through one portal exceeded 7000 r, and a few receiving as much as 10,000 r with one or another form of supervoltage radiation, mostly cobalt. One can very well anticipate the dreadful injuries that will ensue. With supervoltage irradiation one must avoid using a single portal or two cross-firing portals when delivering large tumor doses except for certain anatomical situations.

Stomach

I shall now illustrate our first experience with a new type of radiation disaster, radiation-induced perforating ulcer of the stomach. A patient had an inoperable metastatic retroperitoneal node measuring 6 by 10 cm. It was teratocarcinoma, i.e., trophocarcinoma with many mature radioresistant organoid structures, many of them indistinguishable from normal organs. Consequently a large tumor dose was required.

Through an anterior and posterior cross-firing portal, a tissue dose of 6400 rads in 33 days was delivered to the tumor and adjacent stomach. Symptoms

of epigastric distress and pain started two months later. Four months later this ulcer was demonstrated radiographically (Fig. 7a). At the time we felt a large palpable mass, thought to be a recurrent tumor, which had eaten its way into the stomach. We deferred surgery, believing the prognosis was hopeless.

I wish to stress this feature because we have since described this lesion on a number of occasions. I know

dominal carcinomatosis and adhesions. Had he been more aggressive and separated the adhesions, he



Fig. 6a—Persistent postirradiation pigmentation over the lower dorsal and lumbar spine regions six months after a skin dose of 4000 r in 70 days from 200-kv X rays.



Fig. 6b—Radiation-induced osteogenic sarcoma, beginning to ulcerate through the skin four and one-half years after 4000 r.

of a number of instances since then in which an epigastric mass appeared after heavy irradiation and surgery was unduly deferred; or after exploration the surgeon backed out, believing he was dealing with ab-



Fig. 6c—Radiograph of lower dorsal spine region showing radiation-induced subcutaneous calcification (arrow), which is apparently not related to any of the bones.



Fig. 6d—Radiograph made shortly before patient's death, six and one-half years after X-ray treatment. The sclerosing osteogenic sarcoma has recurred locally and metastasized to an axillary node (arrow).

could have disclosed a nonmalignant radiation ulcer that could have been excised.

The stomach was resected. Figures 7b and 7c illustrate the perforating ulcer. Others may not have a perforated ulcer, but a shallow depressed ulcer of the antral mucosa with numerous petechiae and loss of rugal folds (Fig. 8). The irradiated portion of the

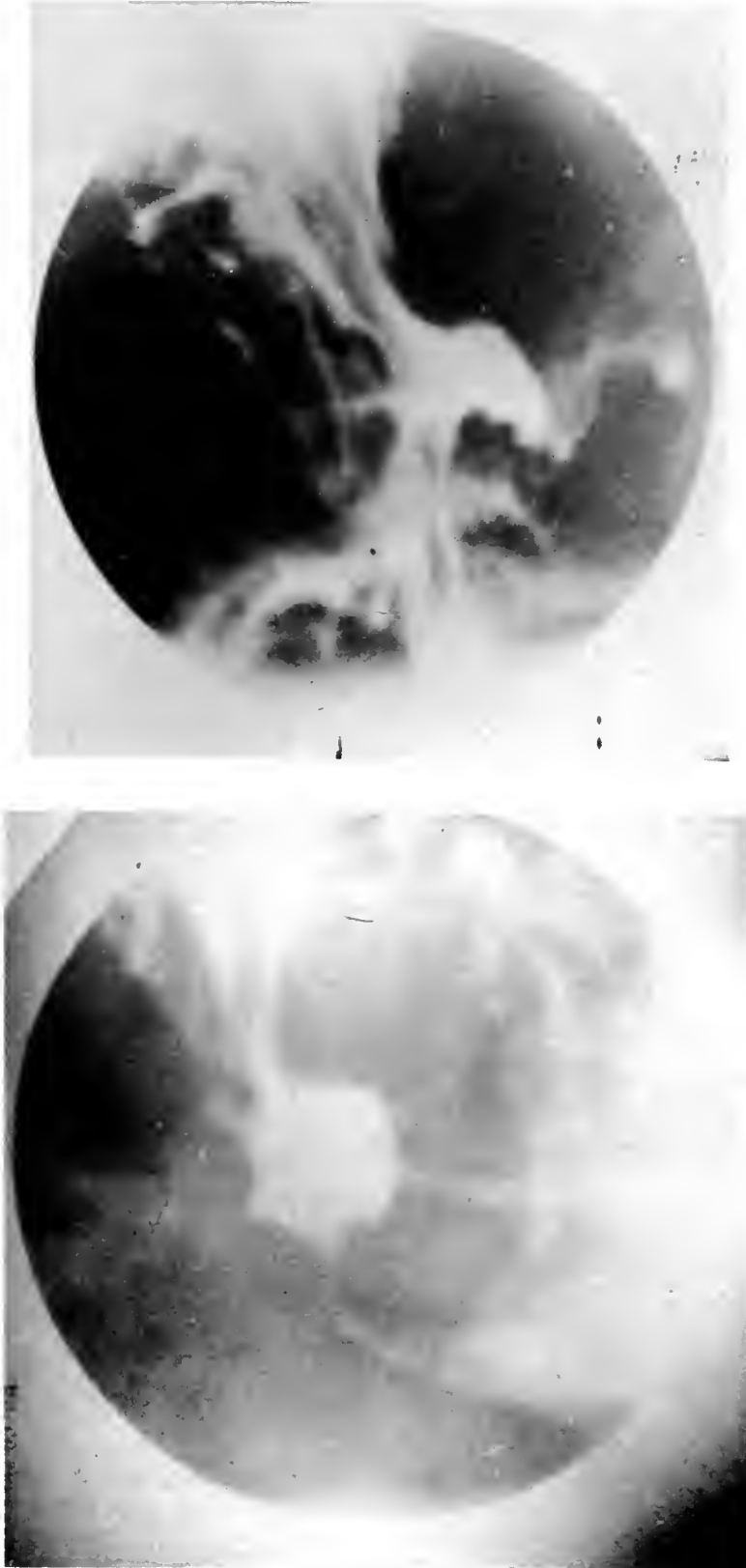

Fig. 7a — Radiation-induced ulcer of the stomach four months after a tissue dose of 6400 rads in 33 days.

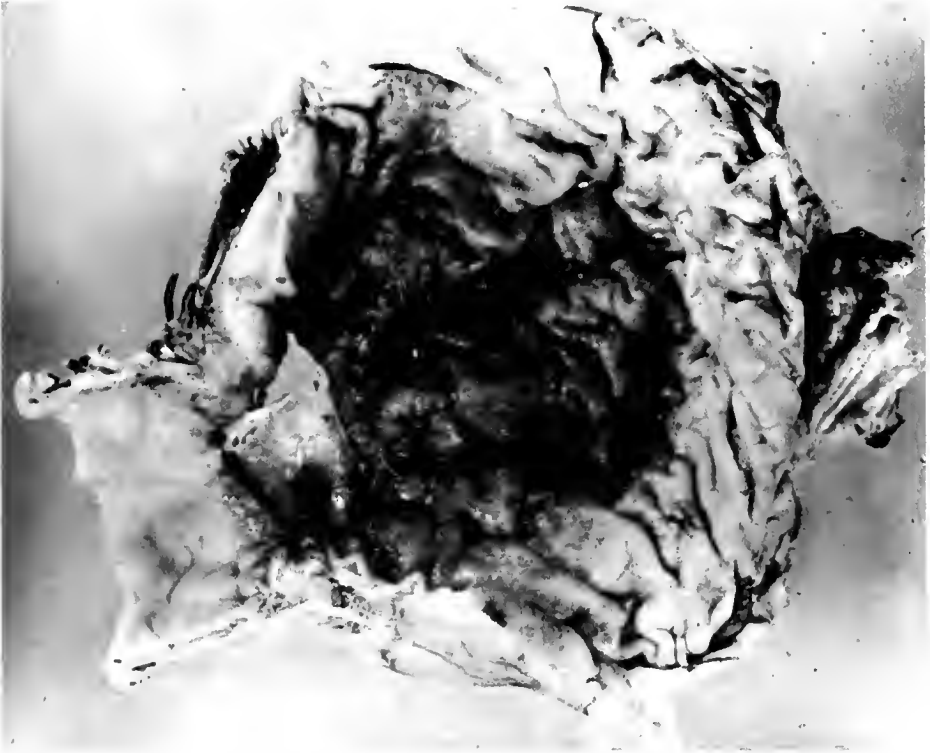

Fig. 7b — Perforated ulcer of the stomach, interior view. Surgical specimen.



Fig. 7c — Perforated ulcer of the stomach, exterior view. Surgical specimen.

stomach looks obviously different from the unirradiated portion. Often, in the absence of an ulcer, large quantities of blood may ooze from a more or less in-

there is seen spasm or permanent narrowing of the antrum. Gastroscopic examination will also disclose narrowing of the antrum, together with loss of rugal



Fig. 8—Nonperforated radiation ulcer of the stomach. Partial gastrectomy was performed several months after irradiation. Note the loss of rugal folds and the submucosal petechiae. Note also the marked thickening of the submucosal connective tissue layer.

tact but heavily irradiated membrane, further confusing the clinical picture. Some patients bleed from an open vessel.

The stomach in Fig. 9 had received an enormous dose of 6000 rads in 47 days. Note the thickened and edematous submucosal connective tissue. This was found in a number of the removed stomachs.

There were four types of injury: (1) radiation dyspepsia, (2) radiation gastritis, (3) radiation ulcer, and (4) radiation ulcer with perforation or obstruction. These lesions represent progressively more severe degrees of injury (Fig. 10). The higher the tissue dose the greater is the percentage incidence of injury and the more severe is the nature of the injury. The peptic ulcer (incidence, 7 per cent) in patients who received the smallest dose was probably not caused by the irradiation. Figure 10 is useful in evaluating the degree of calculated risk of injury to be undertaken when one irradiates advanced cancer. With improved techniques, such as supervoltage rotation, these injuries have been almost completely eliminated.

Radiation dyspepsia consists of vague gastric symptoms with no clinically demonstrable abnormalities. It may begin from six months to four years after irradiation.

Radiation gastritis is attended by symptoms of chronic gastritis but differs from dyspepsia in that there are demonstrable lesions. Radiographically,

folds and possibly atrophy of the mucosa. Gastritis occurs earlier than dyspepsia, the median time after irradiation being two months and the range, from 1 to 11 months. The pathologic effect is fibrosis, with or without edema, of the submucosa.

Radiation ulcer resembles peptic ulcer radiographically but not clinically. Symptoms are not related to meals and are supplemented by symptoms of severe chronic gastritis. This may occur one month to six years after irradiation. The median time is five months. The ulcer may heal spontaneously, but there remains moderate to marked constriction of the lumen of the antrum caused by submucosal fibrosis. This type of ulcer ranges in diameter from 0.5 to 3 cm. Its nature and pathogenesis are not clear because the adjacent and equally irradiated gastric mucosa usually shows no evidence of radiation injury. The best treatment is elective partial gastrectomy. Conservative medical treatment is unwise because, should the ulcer heal, the subsequent gastritis would be discommoding to the patient.

Radiation ulcer with perforation is an early, acute lesion, occurring usually one to two months after irradiation. The perforation is usually walled off by bowel and adhesions, forming a lump, which deceives the inexperienced surgeon into making a diagnosis of inoperable metastatic cancer. Most patients in this series died because surgery was unduly delayed. Cor-

rective surgery should be performed as early as possible, preferably before perforation has occurred.

The severity of the damage was related to the dose. At each dose level a certain number of patients escaped injury. For example, with tissue doses to the

He was asymptomatic for four and one-half years, when symptoms and radiographic signs of partial intestinal obstruction appeared. He was operated upon successfully, and the middle portion of the transverse colon was resected. In Figs. 11a and 11b, the con-

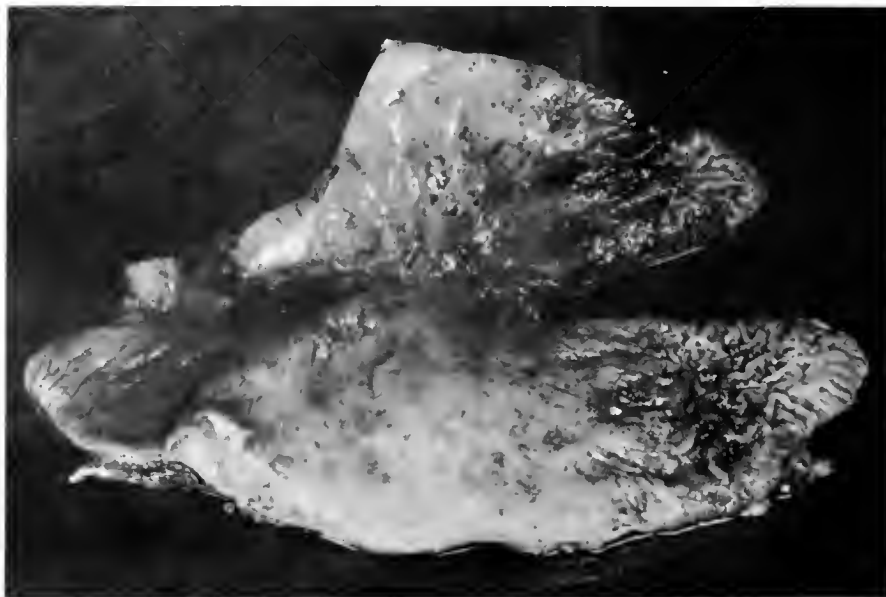

Fig. 9—Surgical specimen of a stomach similar to that in Fig. 7.

stomach of 5500 to 6400 rads, 37 per cent of the patients escaped injury. This illustrates the degree of calculated risk accepted when destruction of some radioresistant cancers is undertaken. This risk is warranted when no other hope of cure exists. At the more common dose levels of 3500 to 4400 rads, only 25 per cent of the stomachs are injured; at 4500 to 5400 rads, the chances of injury are 50 per cent (Fig. 10).

Although the incidence of radiation injury is high, we became alerted to it and modified our techniques and dosage to minimize it. At present, in only 2 or 3 per cent of the instances does one find an inoperable radioresistant mass behind the stomach for which dangerously large doses might be required. One must accept a risk of 63 per cent possible injury of the stomach in exchange for lethal effects on the tumor with doses ranging from 5500 to 6400 rads.

Transverse Colon

This is one of the most interesting of all radiation injuries. The irradiation, although traversing all musculoskeletal and visceral structures from the skin of the abdomen to the skin of the back, selectively affects the loose connective tissue of the submucosa of the transverse colon. Maturation and hyalinization of the connective tissue layer is followed by progressive ringlike constriction finally resulting in intestinal obstruction.

The patient in Figs. 11a to 11d had received a tissue dose of 5600 rads in 83 days to the transverse colon.

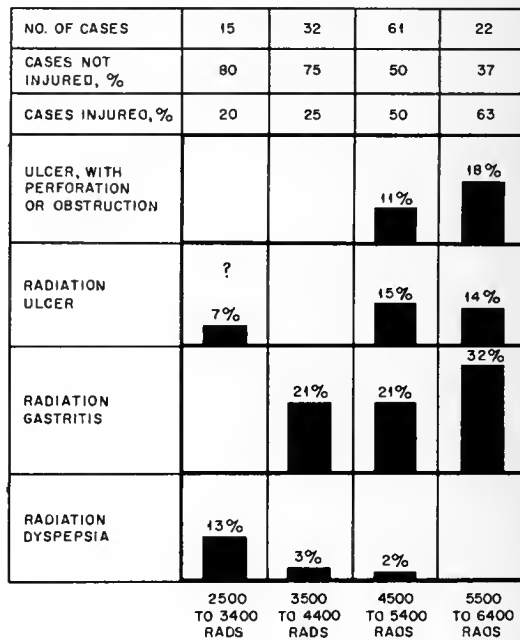

Fig. 10—Types of injury of the stomach produced by different tissue doses during the course of irradiation of the retroperitoneal nodes in a group of 130 cases of tumors of the testis.

tracture of the thickened submucosal connective tissue layer, which was not only centripetal in direction but also from both ends toward the middle, can be seen.

The irradiation portal originally was 10 cm wide, but four and one-half years later only 5 cm of the transverse colon showed radiation changes. Within the obstructed gut the mucosa was intact. The submucosa, instead of containing loose connective tissue, was

I have seen this phenomenon occur in many other tissues, but it caused no trouble and was only of academic interest. In the transverse colon the loose connective tissue sustained late radiation injury, whereas the mucosa muscularis and serosa were intact.

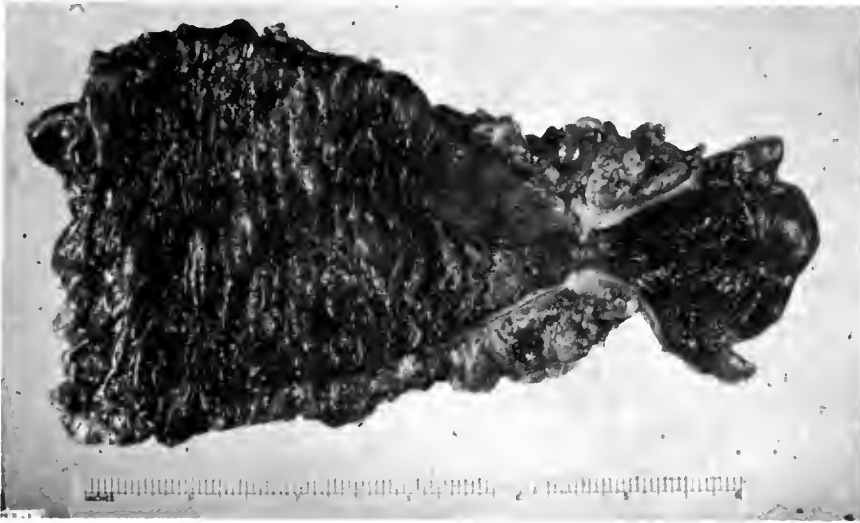

Fig. 11a — Removed segment of irradiated transverse colon four and one-half years after a tissue dose of 5600 rads in 83 days. Note the white ring of constricted submucosal fibrous connective tissue, which had produced almost complete intestinal obstruction.

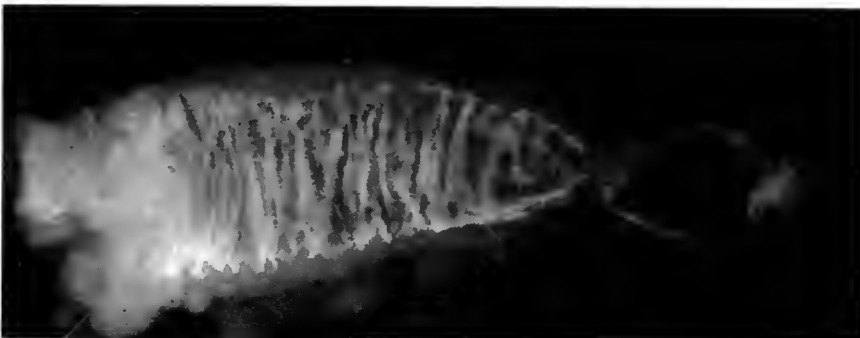

Fig. 11b — Radiographic corroboration of findings in Fig. 11a.

densely hyalinized, and this was responsible for the contracture (Figs. 11c and 11d). The serosa was intact.

The transverse colon (as well as the antrum of the stomach) is particularly susceptible to injury because its fixed position exposes it continuously to irradiation.

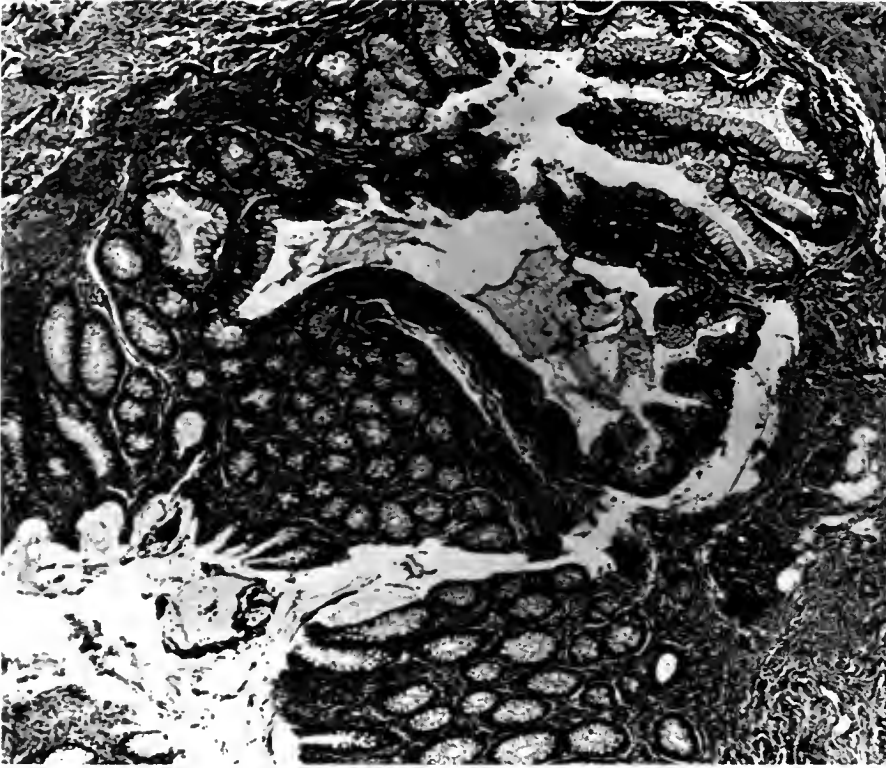

Fig. 11c—Cross section of complete mucosal lining at the most constricted part. The mucosal glands show no radiation changes except for one dilated duct.



Fig. 11d—Dense hyalinized fibrosis of the submucosal connective tissue. This is the tissue that produced the contracture and intestinal obstruction.

tion. There are three degrees of irradiation injury: (1) asymptomatic constriction, (2) partial obstruction, and (3) perforation (Fig. 12). The percentage incidence of injury, as well as the degree of injury, is proportional to the tissue dose. In general, the transverse colon is more radioresistant than the stomach and requires larger doses for the production of injury.

NO. OF CASES	11	9	20	23	57
CASES NOT INJURED, %	82	89	90	83	63
CASES INJURED, %	18	11	10	17	37
PERFORATION					5%
PARTIAL OBSTRUCTION	9%	11%	5%	13%	25%
ASYMPTOMATIC CONSTRICTION	9%		5%	4%	7%
	4000 TO 4400 RADS	4500 TO 4900 RADS	5000 TO 5400 RADS	5500 TO 5900 RADS	6000 TO 6400 RADS

Fig. 12—Type and incidence of injury to the transverse colon during irradiation of retroperitoneal nodes for carcinoma of the testis in relation to dose.

Asymptomatic constriction was discovered only when routine barium-enema examinations were performed five years after treatment. It was found in seven patients whose tissue dose had ranged from 4000 to 6400 rads. The lesion begins several years after irradiation. Occasionally it is progressive.

The mean latent period for partial intestinal obstruction is 12 months, the range being 4 to 60 months. It is usually preceded, for different lengths of time, by asymptomatic constriction. The treatment is surgical removal of the irradiated bowel.

Perforation of the transverse colon is an early acute lesion occurring within one or two months after irradiation or a delayed lesion occurring several years after irradiation. The latter type probably results from progressive endarteritis obliterans. Perforation occurred only in patients whose tissue dose was larger than 6000 rads.

The incidence of injury to the transverse colon and the severity of the lesions are proportional to the dose. In general, it requires a larger dose to injure the transverse colon than the stomach. Whereas a dose of 4500 rads injured 50 per cent of the stomachs, it injured only 11 per cent of the transverse colons. Furthermore, doses as large as 6000 to 6400 rads injured only 37 per cent of the transverse colons.

On the other hand, in a critical case we must remember that, with tissue doses of 6000 to 6400 rads, 63 per cent can escape injury. The calculated risk of possible injury to the transverse colon is less than the risk of injury to the stomach.

Small Intestine

The small intestine is vulnerable to the same doses as the transverse colon. Heavy irradiation often produces a saw-tooth irregularity (Fig. 13). The tolerance dose of the small intestine is difficult to evaluate because its continual motion withdraws it intermittently from the irradiation field. Factitious adhesions, which immobilize the bowel, may increase the possibility of radiation injury.

Injury to the small intestine may occur at any time after irradiation. In this series the only arrested case of chorio-epithelioma with metastatic nodes was complicated four years later by three independent perforations of the small intestine. The premonitory symptoms had been mild and of two months' duration.

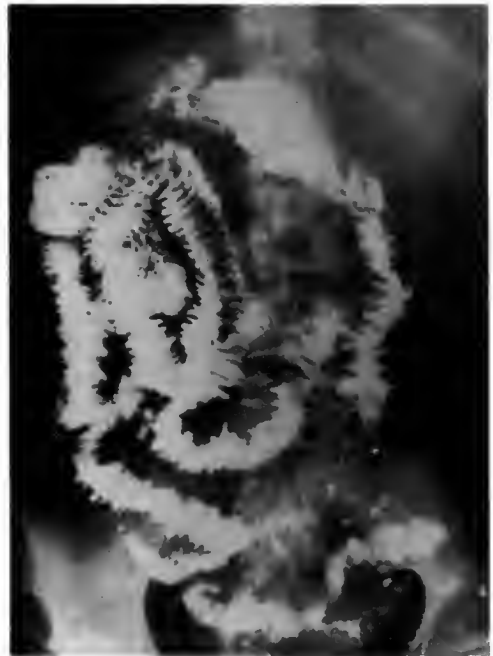

Fig. 13—Saw-tooth pattern characteristic of late radiation effects on the small intestine.

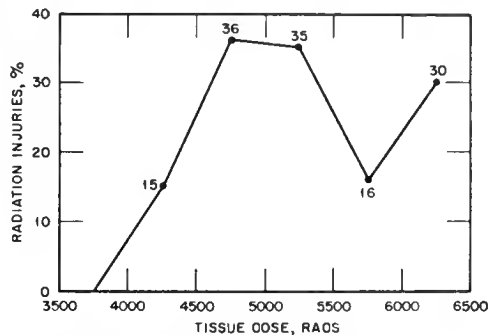

Fig. 14—Percentage incidence of small bowel injuries of all types in relation to the tissue dose.

The incidence of injury to the small intestine in relation to dose is illustrated in Fig. 14.

Mesentery

The mesentery, containing loose connective tissue, undergoes massive fibrous contracture. This produces no symptoms, but a specific configuration of academic interest. As a result of contracture of the mesocolon, the entire colon shifts from its normal location and occupies a circular position around the periphery of the abdomen; its radius becomes shorter and it loses the two upper flexures. This was observed in eight patients receiving tissue doses of 4500 to 6000 rads or more.

Rectum

The rectum is different from the rest of the intestines. In many patients we have delivered doses of 8000 to 10,000 rads to the rectum, using 2-Mv rotation, without injury. In a recent case of chordoma of the sacrum similarly irradiated, we delivered a tissue dose of 13,000 rads in 70 days to the rectum. There has been no injury during the nine months following treatment. We are in a position to state that, on the basis of about 70 to 80 cases, the rectum is much more radio-resistant than the rest of the intestines and can tolerate tissue doses of 8000 to 10,000 rads without succumbing to serious radiation injury.

Kidney

In our series of tumors of the testis, the 10-cm width of the portals encompassed only the medial portions of the average patient's kidneys. However, eccentric or atypically wide portals were used in many patients, and many kidneys were heavily irradiated. The only injury we observed was the contracted kidney.

At the five-year follow-up study, intravenous pyelogram, blood chemistry, and urine studies were performed on 104 patients. Fifty patients had received 3500 to 6000 rads to a kidney. Seven atrophied kidneys (14 per cent) were found (Table 2). It was estimated that the tolerance dose of the kidney is 4000 rads in 50 days.

Table 2—KIDNEY EFFECTS*

Dose, rads	No. of cases	Atrophied kidneys	
		No.	Percentage
3500-3999	8	1	16
4000-4499	10	2	20
4500-4999	9	0	0
5000-5499	10	2	20
5500-5999	13	2	15
Total	50	7	14

*Frequency distribution of 50 patients who received 3500 to 6000 rads to the kidneys.

Basing our judgment on histologic study of kidneys removed at the post-mortem examination of patients who died of metastasis or other causes, we believe that the tissue dose required to destroy a kidney is 7000 rads in 50 days.

The Manchester, England, group irradiated the abdomen with orthovoltage X rays using the trunk-bridge technique. They observed serious and sometimes fatal renal damage with tissue doses higher than 2300 rads to the whole of both kidneys. This is an undesirable technique for tumors of the testis because it is unnecessary to irradiate the entire abdomen. However, in massive lymphoma involving the entire abdomen, the irradiation may endanger the kidneys, and they must be blocked off with lead shields.

Spinal Cord

One hundred patients in this series had received tumor doses to the spinal cord ranging from 5000 to more than 7000 rads. Ten patients (10 per cent) sustained injury of the spinal cord (Table 3).

Table 3—SPINAL-CORD INJURY

Tissue dose, rads	Degree of injury				Total No. of cases	Incidence of injury, %
	Mild	Moderate	Severe	Total		
5000 to 5999	2	1	2	5	43	12
6000 to 6999	2	1	1	4	46	9
7000 and over		1		1	11	9
				Total	100	10

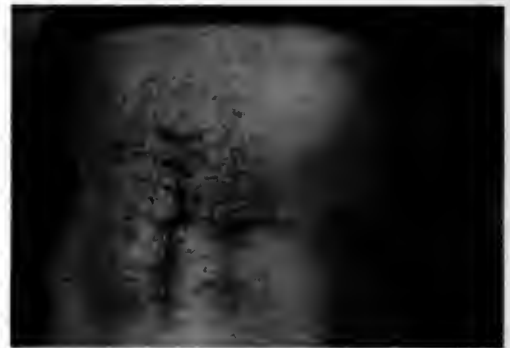

Fig. 15—Massive retroperitoneal leiomyosarcoma 10 years after a tumor dose of 6500 rads in six weeks.

The intensity of damage ranged from mild weakness of one extremity to bilateral flaccid paraplegia of both lower extremities. Histological examination of the irradiated spinal cord showed vacuolation of the myelin sheath and some replacement fibrosis.

Another patient, not in the testis-tumor series, was a young woman with a massive right retroperitoneal leiomyosarcoma, 15 by 18 cm, which filled one abdominal gutter, extended across the mid-line, and pushed all the intestines to the left side. We used large anterior and posterior portals (Fig. 15). In 1944, the tumor, one kidney, and the spinal cord received tissue doses of about 6500 rads in six weeks. All tissues from front to back were included in a solid fixed

cube of dense fibrosis. The patient has no tumor today, twelve years later, but the right kidney is nonfunctioning, and her lower extremities are 75 per cent paralyzed as a result of spinal-cord injury.

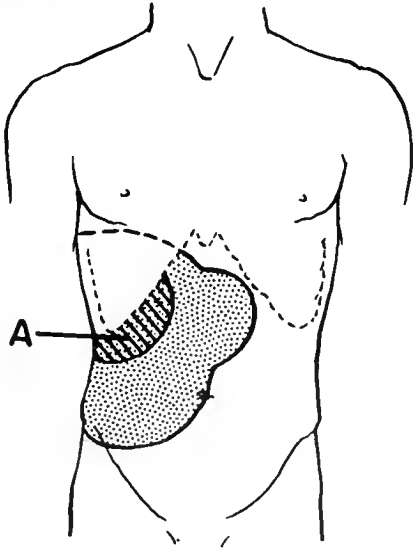

Fig. 16a—Massive retroperitoneal fibrosarcoma filling the entire right abdominal cavity. One portion (A) bulged the anterior abdominal wall.



Fig. 16b—Mass in the right abdomen displacing all viscera. Right kidney was pushed up under the diaphragm.

On the other hand, massive retroperitoneal fibrosarcoma may be effectively treated by using a proper technique. The patient in Fig. 16a was explored, and a fixed inoperable mass was found which filled the

entire right abdominal cavity. The kidney was pushed up to the diaphragm, and the intestines were displaced to the left side of the abdomen (Fig. 16b). A biopsy specimen was removed. Through five portals a total tumor dose of 8356 rads in 63 days was given with 1-Mv X rays. The mass shrank 60 per cent. One month later the surgeon was able to remove the entire tumor. The intestines and right kidney returned to normal



Fig. 16c—Postoperative pyelogram. Tumor shrank 60 per cent in volume and was easily removed.

position (Fig. 16c). There has been no recurrence of disease for six years, and there has never been any evidence of injury to the kidneys or intestines.

Table 4—LATENT PERIOD BEFORE ONSET OF RADIATION INJURY*

Organ	Median time, months	Range, months
Stomach	3.4	1 to 72
Small intestine	25	1 to 60
Transverse colon	21	2 to 60
Spinal cord	12	4 to 60

*In general, severe lesions appeared early and mild lesions occurred later. Mild stomach lesions tended to heal spontaneously. Lesions of the transverse colon usually began later and became progressively more severe.

Although some of our doses were unduly large, there remains the occasional necessity for delivering doses of 5000 to 6000 rads to a tumor near the spinal cord. In this event, the calculated risk of injury is 12 per cent (Table 3) unless a rotation technique is

used which will reduce the dose as well as the risk of injury to the spinal cord.

Latent Injury Period

Table 4 indicates the latent period between irradiation and onset of radiation injury. Note the marked range of this latent period.

Methods for Circumventing the Barrier of Normal Tissue Intolerance

For efficient irradiation the high dosage volume must be confined to the region of the tumor, and the tissue dose to the adjacent normal tissues must be at a minimum and less than the doses listed in Table 5, a useful guide in therapy, which gives the tolerance doses for a number of normal tissues. The following examples are based on a 2-Mv X-ray resonant-transformer generator manufactured by General Electric Corporation.

Tumor near the Spinal Cord

For example, here is the problem presented by a patient with a chordoma of the fourth lumbar vertebra

(Figs. 17a and 17b). The edge of the tumor was 1 cm from the cauda equina. We wanted to deliver 7200 rads to the tumor (area within the circle), keeping the dose to the cauda equina less than 5000 rads. We used 360-

Table 5—TOLERANCE DOSES OF NORMAL TISSUES

Organ	Tissue dose, rads	Over-all time, weeks
Stomach	3500	5-9
Transverse colon	4500	5-9
Central nervous system	5000	5-9
Small intestine	4200	5-9
Rectum	8000	5-9
Kidneys (part of each)	5000	5-9
Kidneys (all of both)	2500	3-6

deg rotation, the portal being 6 by 6 cm. The isodose curves (Fig. 17c) which were obtained by densitometry from a film exposed under treatment conditions (Fig. 17d) show a rapid fall-off in dosage gradient from the high dosage volume to the adjacent cauda equina, which received only 4400 rads (about 60 per cent of the

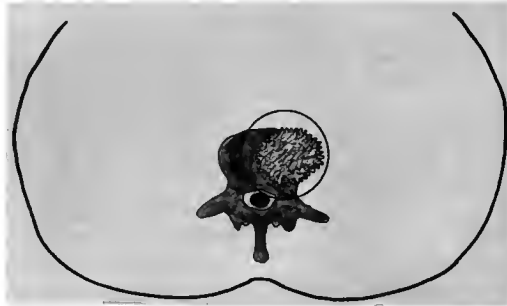

Fig. 17a—Cross-section diagram of a patient with chordoma of the fourth lumbar vertebra.



Fig. 17b—Chordoma of the fourth lumbar vertebra before treatment September 1952. The lesion involved the anterior and right half of the body of the vertebra and bulged into the soft tissues.

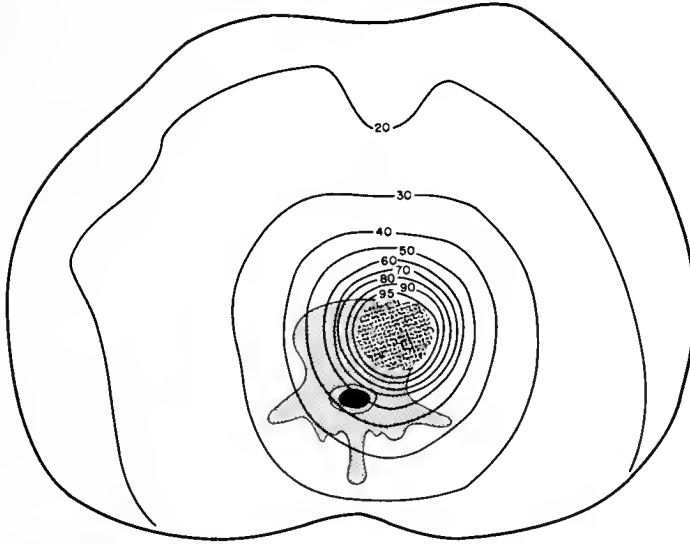

Fig. 17c — Isodose curves made from film in Fig. 17d. The portal was 6 cm wide.

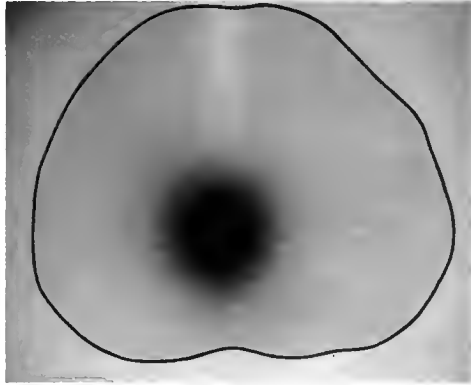

Fig. 17d — Radiograph made with 2-Mv X rays. The film was placed in a phantom reduplicating the patient and rotated 360 deg. The density is proportional to the dose. The lighter streak at the top is the shadow cast by the supporting column on the rotating platform.

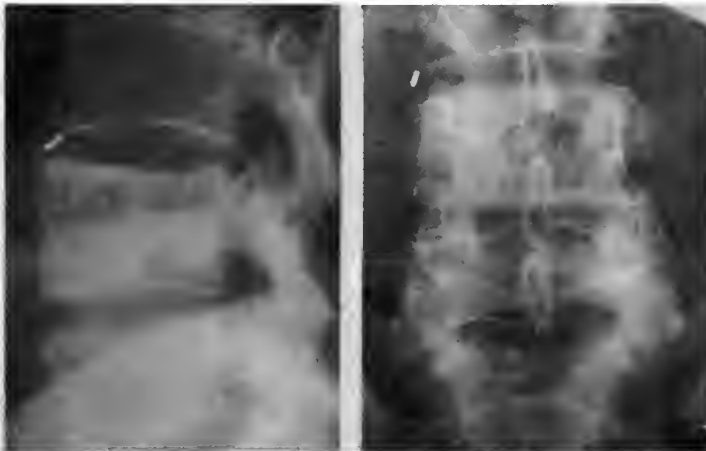

Fig. 17e — Healed chordoma. The radiograph was made two years after treatment. The tumor has been arrested for five years as of September 1957.

maximum tumor dose). This indicates a high index of efficiency (see Appendix B) for the technique. The factors most responsible for this excellent dose distribution were the narrow penumbra and the relatively small field size. The lack of good collimation is one of the weaknesses of the currently available rotating cobalt machines, whose broad penumbra makes impossible the undertaking of this type treatment. A rotating cobalt machine, poorly collimated, would have delivered almost 7000 rads to the cauda equina and would probably have injured it. The chordoma in this patient has been arrested for almost five years (Fig. 17e).

Large Volumes of Tissue

If a large volume of tissue, with respect to the total area of the body cross section, must be irradiated, the usefulness of rotation decreases materially. Figures 18a and 18b illustrate a pelvis irradiated with a 15-cm-diameter cylinder. The skin received about 45 per cent of the tumor dose, which is a rather large amount. The integral dose is also large, but it is of no practical importance. The technique was used for stages III and IV carcinoma of the cervix. We used 2-Mv rotation only. Figure 19 is a scatter diagram of the doses used in this series of cases and represents

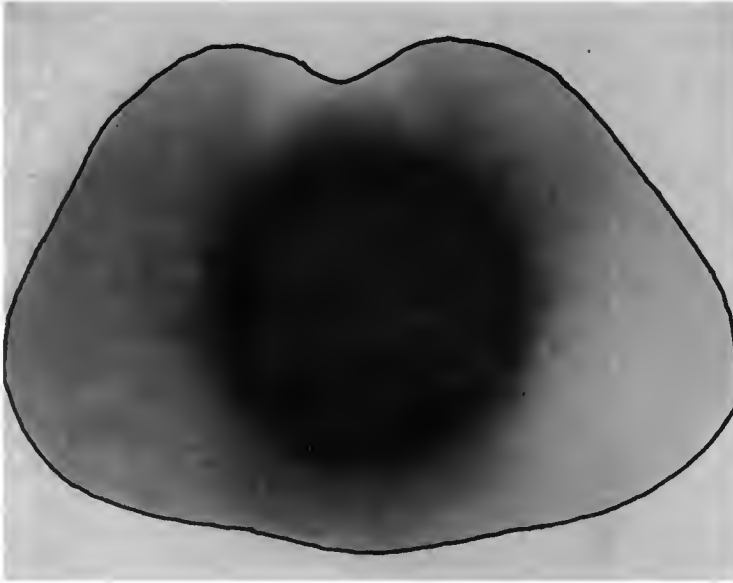

Fig. 18a—Dosage distribution with 2-Mv X rays and rotation, using a 15-cm-diameter portal. Note the marked increase in dose to the normal tissues.

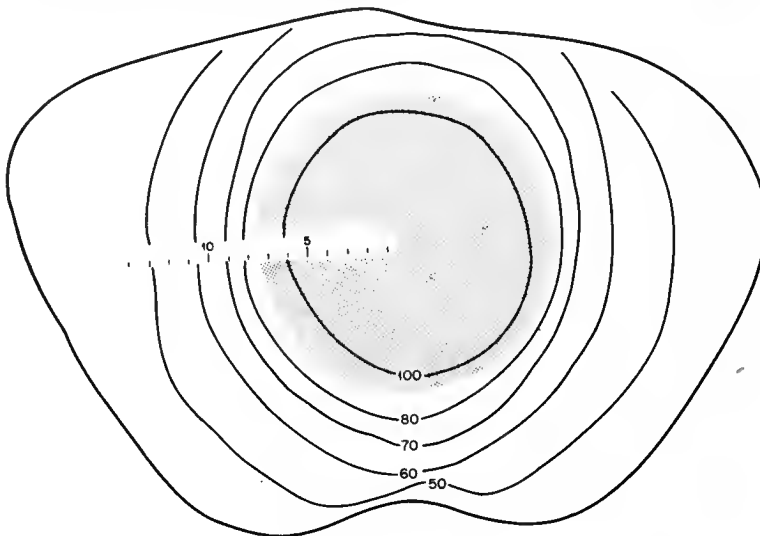

Fig. 18b—Isodose curves derived from the film in Fig. 18a. The efficiency of rotation diminishes as the size of the field increases.

the spectrum of tumor lethal doses required for advanced carcinoma of the cervix. Note that four lesions that received tumor doses of about 10,000 rads failed to achieve primary shrinkage. Others responded after

tion technique of 270-deg rotation for a recurrent mass in front of the sciatic notch which causes severe sciatic pain. To a cylinder 7 cm in diameter, we were able to deliver safely a tumor dose of 8300 rads in six weeks with 2-Mv X rays and 270-deg rotation, causing no untoward symptoms or sequelae. The recurrence has been held in check for two years.

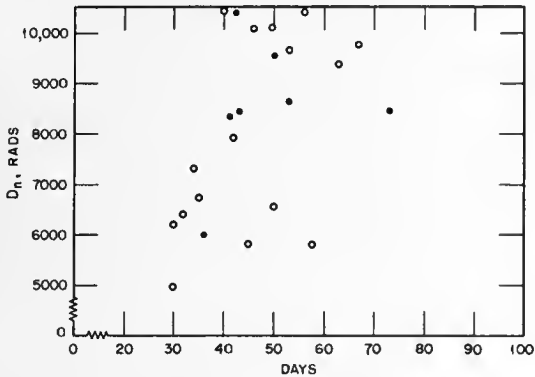

Fig. 19—Scatter diagram of tumor doses used for a series of advanced carcinoma of the cervix (stages III and IV) treated exclusively by supervoltage (2-Mv) X rays with rotation. ●, doses producing primary shrinkage and apparent arrest of the tumor for one to three and one-half years. O, failure.

similar or smaller doses. Note the broad range of tumor dose required and the large doses necessary to destroy a significant percentage of tumors. These doses entail a calculated risk of radiation injury, which must be accepted. Many of the required doses are enormous. It is possible to deliver safely these enormous doses up to 10,000 rads with supervoltage X rays and the rotation technique. It is necessary, however, to keep the portal below the level of the small intestines, which are vulnerable. The rectum can tolerate these large doses.

Accurate Beam Aiming

Accurate beam aiming is required in delivering large tumor doses to a carcinoma of the cervix with the rotation technique. I shall not give the details but shall indicate a few features in Fig. 20, which is a double-exposure port film taken with a 2-Mv X-ray beam. A small ring packed against the cervix in the upper vagina, air in the bladder (75 cm³), a crotch bar, which the patient straddles and which is notched at 5-cm intervals for correction of the distortion, and four brass markers on the skin at the four compass-poles with respect to the axis of rotation (indicated by the broken line) can be seen. Three small pointed markers are placed over the suprapubic and both lateral hip regions. The posterior marker is the bottom of a large ring, which serves several functions, including correcting for distortion. When the film is exposed and developed, the accuracy of the position of the portal is checked.

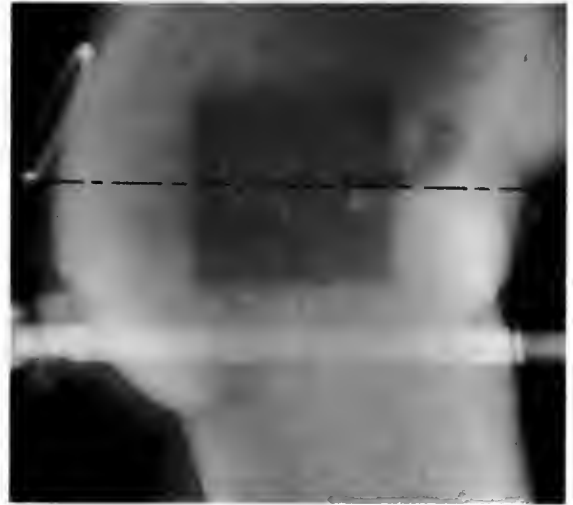

Fig. 20—A 2-Mv portal film made before treatment for carcinoma of the cervix.

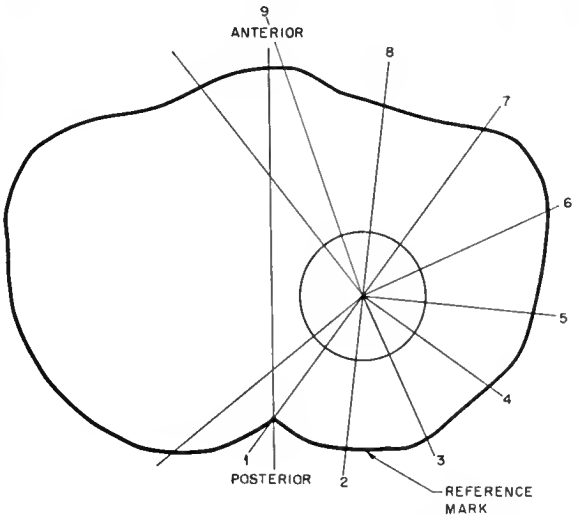

Fig. 21—Irradiation technique for carcinoma of the cervix in the form of a presciatic mass, recurrent after previous radium and X-ray therapy.

Beam-shaping Devices

Recurrent Carcinoma

Supervoltage rotation irradiation can be used safely for recurrent carcinoma of the cervix (at the periphery of the pelvis) after previous irradiation with radium and 200-kv X rays. Figure 21 illustrates the irradiation

When a vulnerable organ, included in the cylinder of high dosage, produces early symptoms of irradiation effect, it can be blocked off by beam-shaping devices. A young woman had a malignant mesenchymal tumor of the uterus, which had infiltrated the pelvic floor and metastasized bilaterally to the iliac nodes. At

laparotomy, only a small portion of the tumor was removed. Supervoltage rotation irradiation was started

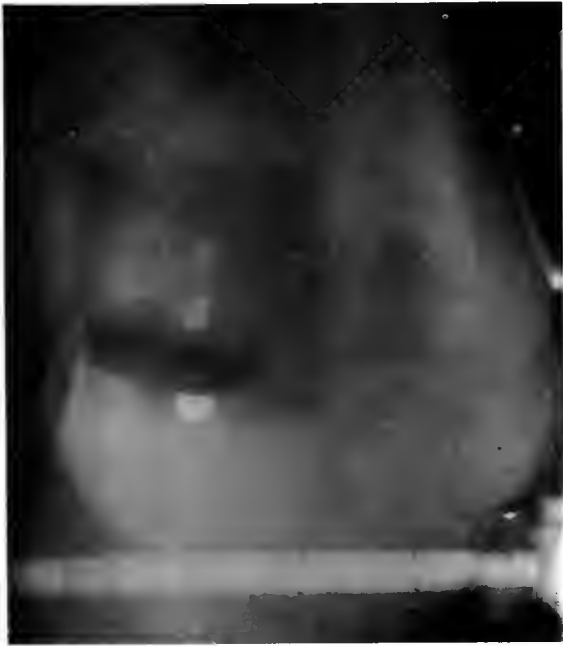

Fig. 22a — Port film of malignant mesenchymal tumor of the uterus infiltrating the pelvic floor and metastasizing bilaterally to iliac nodes.

against the cervix, and skin markers. It can be seen that some small intestine was included in the field. After a tissue dose of 2000 rads, diarrhea became very severe. The height of the cylinder was lowered to avoid irradiating the small bowel, and at the same time the diameter was widened to include the entire pelvic floor, which was involved with tumor (Fig. 22c). The irradiation was carried to a tumor dose of 5500 rads, when a violent proctitis and anusitis forced us to stop for a few days. The beam was further shaped

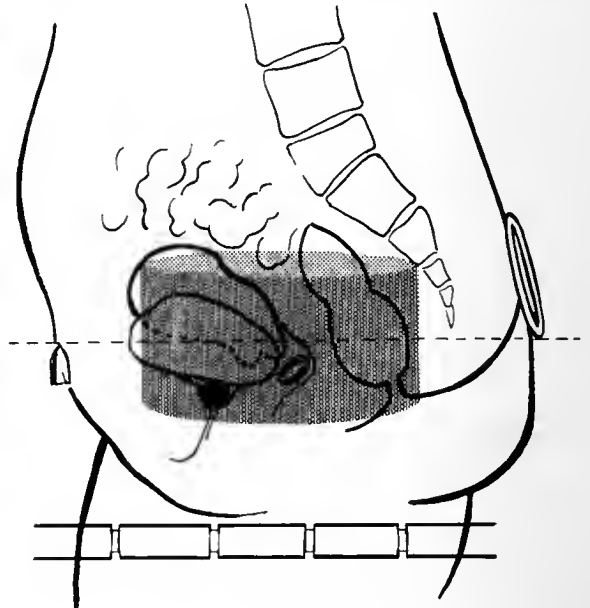

Fig. 22c — The cylinder, reduced in height to exclude the small intestine and increased in diameter to include the posterior extension of the tumor.

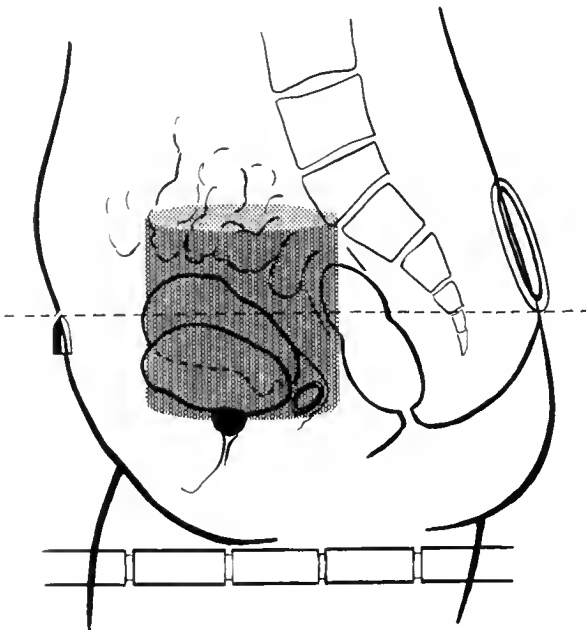

Fig. 22b — Diagrammatic tracing taken from Fig. 22a.

according to the plan illustrated in Figs. 22a and 22b. Figure 22a is a port film showing 5 cm³ of mercury in a small Foley bag at the base of the bladder, air filling the bladder and outlining the ventral aspect of the uterine mass, a crotch bar, a metal ring packed

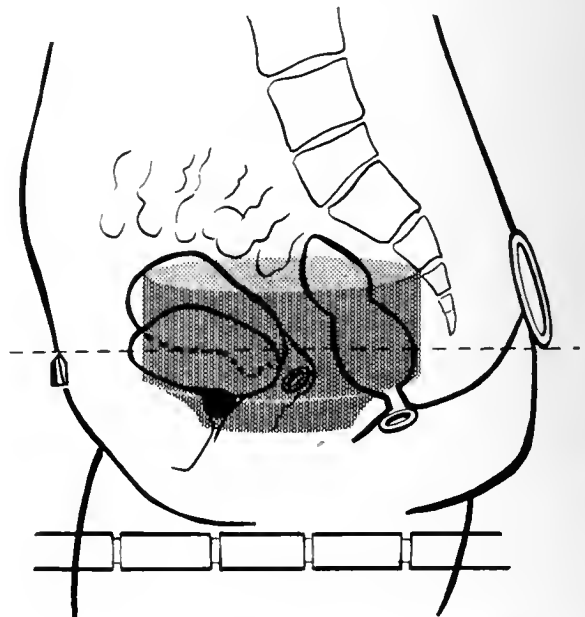

Fig. 22d — Interposed lead blocks modifying the shape of the irradiation cylinder to avoid the anus.

by interposed lead bricks to avoid irradiating the anus (Fig. 22d). The irradiation was then resumed until the total tissue dose to the entire pelvis reached 8250 rads in eight weeks. The disease in the pelvis disappeared and the pelvic floor became soft. The patient died of pulmonary metastasis one and one-half years later without any recurrence in the pelvis.

Advantages of Rotation

I have shown previously that serious injury to the small intestine was produced with tissue doses of 4000 to 6400 rads, when delivered through two cross-firing portals. Yet, when 2-Mv rotation with a 6- by

large dose of irradiation to a deep-seated or recurrent cancer or to deliver a proper dose to a primary tumor and neck-node region "in continuity." Figures 26a and 26b illustrate the treatment of a carcinoma

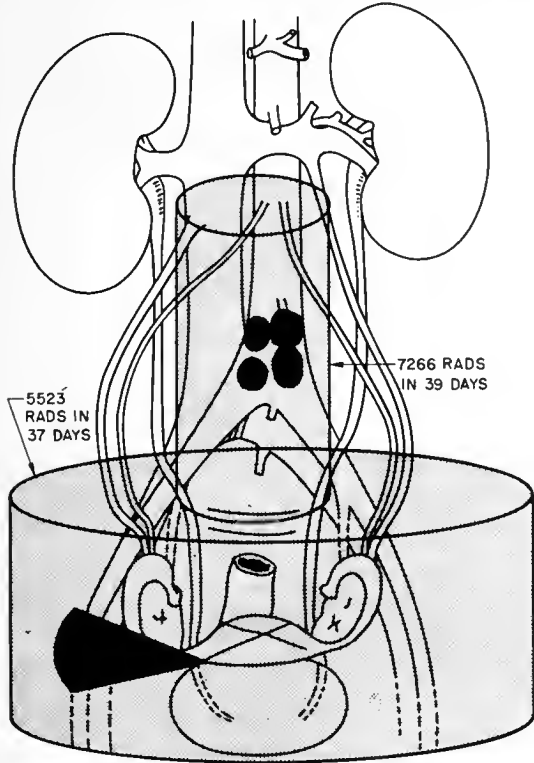

Fig. 23—Carcinoma of the cervix, posthysterectomy, with four residual preaortic metastatic nodes. A tumor dose of 7266 rads was delivered in 39 days.

15-cm field was used for residual preaortic nodes after hysterectomy for carcinoma of the cervix (Fig. 23), we safely delivered 7266 rads in 39 days, and the patient has been well for two years [until September 1957]. This is the largest dose we have ever given to this lymph-node region.

The destruction of bladder cancer with supervoltage irradiation requires large doses ranging from 8000 to 12,000 rads. Even these large doses are often inadequate (Fig. 24). The rotation technique, however, with a sharply collimated beam can provide efficient dose distribution (Fig. 25) to minimize damage to normal tissues adjacent to the bladder.

Supervoltage rotation irradiation is useful in many tumors of the head and neck, either for delivering a

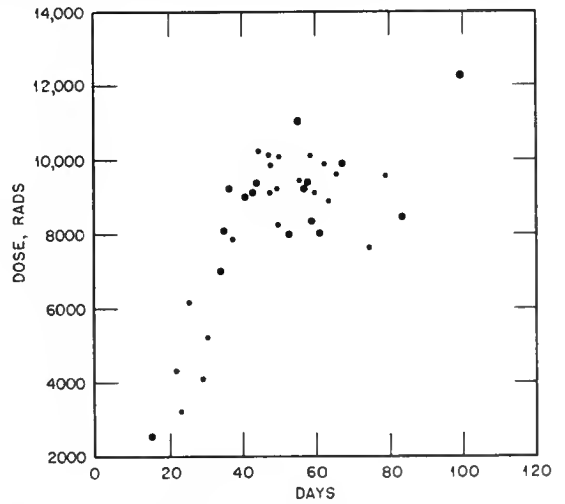

Fig. 24—Scatter diagram illustrating supervoltage tumor doses used in a series of bladder-cancer patients. Note the large doses required (8000 to 11,000 rads) to produce primary shrinkage. ●, tumor arrested (one to three years). ○, tumor not destroyed.

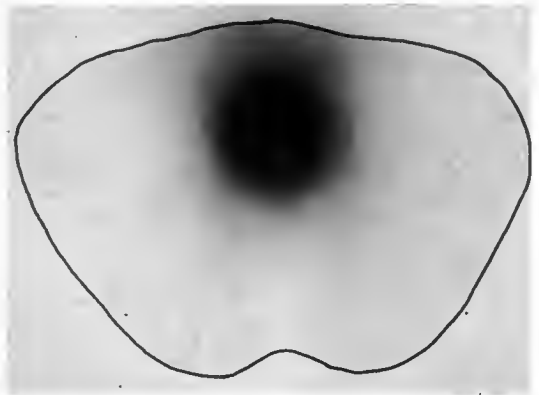

Fig. 25—Concentrated irradiation produced by 2-Mv rotation in the bladder and low dosage to adjacent normal tissues (360-deg rotation; 8- by 8-cm cylindrical field).

of the tongue and neck-node region encompassed within a partially immersed cylinder of high-dosage irradiation. We have often used doses as high as 9000 and 10,000 rads without undue discomfort to the patient. As long as the epithelitis is unilateral, the patient can swallow comfortably. If the penumbra of a particular beam is broad, there is no sharp cut-off of the cylinder of intense irradiation. The consequent extensive epithelitis with its discomfort will prevent the administration of high dosage.

The re-treatment of a local recurrence after previous intensive irradiation can be easily accomplished with supervoltage rotation irradiation. The woman in

Fig. 27, four and one-half years previously, had received to a carcinoma of the nasopharynx a tumor dose of 6000 r with 200-kv X rays through four cross-firing portals. Severe late skin effects resulted and

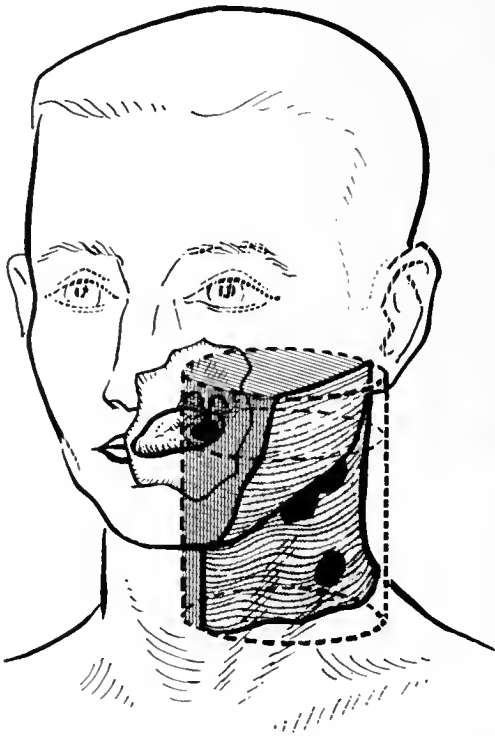

Fig. 26a—"In continuity" irradiation for carcinoma of the tongue with metastasis. A partially immersed cylinder of high-dosage irradiation is used.

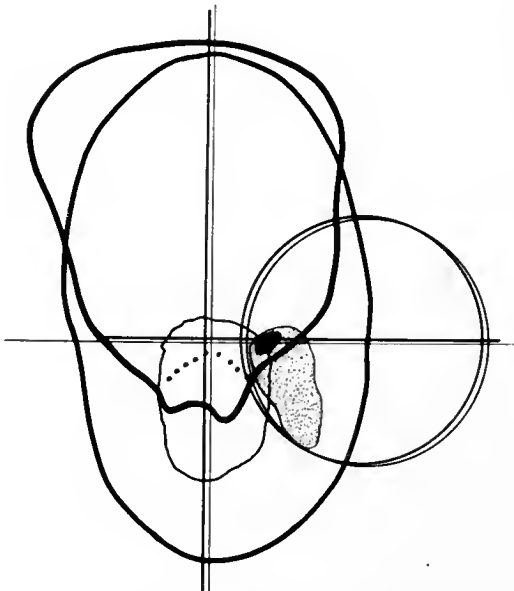

Fig. 26b—Two superimposed contours of the same patient, one at the level of the chin and the other at the level of the vocal cords where the nodes are situated. A rotation pattern is selected to fit the disease.



Fig. 27—Recurrent carcinoma in the nasopharynx. Residual radiodermatitis from previous skin dosage of 4200 r with 200-kv X rays was not aggravated by the second course of 7000 rads with 2-Mv rotation.

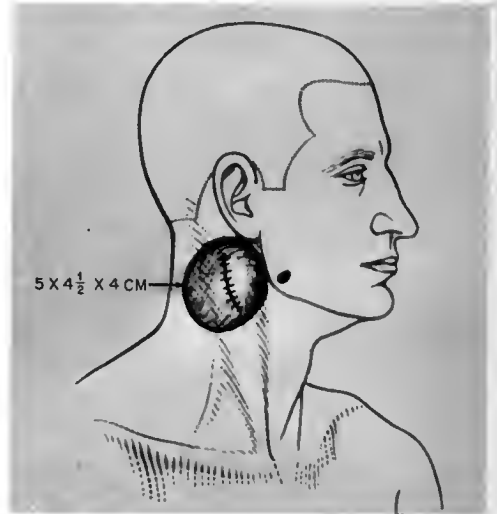

Fig. 28a—Small primary carcinoma of the glossotonsillar sulcus with a large inoperable node. It was irradiated with 200-kv X rays through an 8- by 10-cm grid.

were present at the time a recurrence appeared in the nasopharynx. The lesion was extensive by that time, having destroyed a large area of the base of the skull and bony margin of the foramen magnum. With supervoltage rotation a tumor dose of 7000 rads was delivered without producing a skin reaction or intensifying the chronic radiodermatitis. She died four years later of distant metastasis.

Another special advantage of supervoltage rotation is illustrated in Figs. 28a, b, and c. In December 1951, this man had a metastatic inoperable squamous-cell carcinoma of the neck, arising from a small primary tumor in the glossotonsillar sulcus (Fig. 28a). Both

lesions were successfully irradiated with a single grid portal. The air dose was 14,700 r in 29 days. One year later a second tumor in the left upper buccogingival sulcus was irradiated through an intra-oral

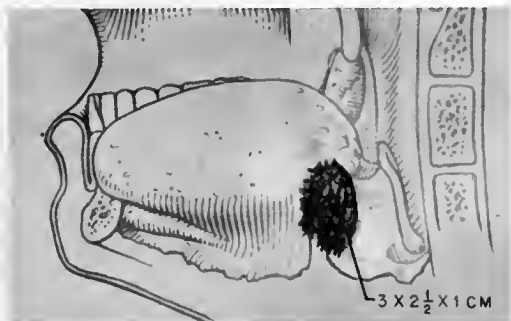

Fig. 28b—The third tumor, appearing three and one-half years after the first. The patient was now aged 86 years.

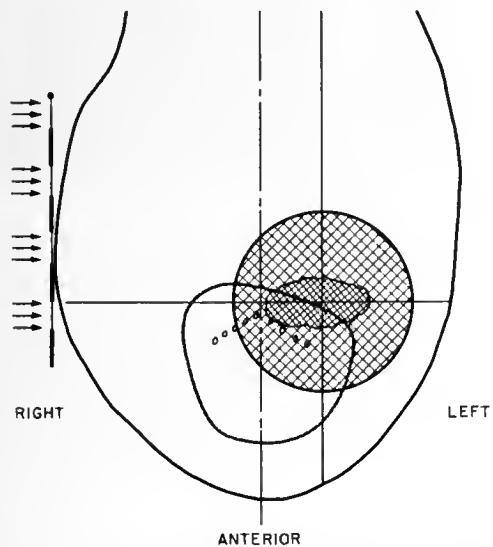

Fig. 28c—Cross section of the head through the center of the third tumor on the dorsum of the posterior portion of the left half of the tongue.

cone. In June 1955, a third independent squamous-cell carcinoma appeared on the left dorsum of the posterior third of the tongue (Fig. 28b). The problem at this time is illustrated in Fig. 28c. The normal tissues near the newest tumor had previously received doses ranging from 3000 to 8000 r through a grid. (The position of the previous grid portal is indicated in Fig. 28c.) We nevertheless irradiated the new tumor with 2-Mv rotation technique. To a cylinder 5 cm in diameter and 5 cm high (indicated by the circle with crosshatching), a tumor dose of 9300 rads was delivered in 39 days. The lesion disappeared.

Another unique advantage of supervoltage X rays in avoiding injury to the eyes is seen in irradiating a carcinoma of the ethmoid sinus or roof of the nasal cavity according to the technique illustrated in Fig. 29. In a well-collimated beam of supervoltage X rays,

the minimal side-scattering prevents damage to the lens or cornea.

I shall show Fig. 30, carcinoma of the esophagus, for two reasons: (1) the tumor was extensive as evidenced by a posterior perforation into the mediastinum, and (2) there was metastasis to Virchow's node. The node, as well as the esophagus, was included in a cylinder of intense irradiation with 2-Mv rotation. The cylinder measured 8 cm in diameter and 17 cm in height. The tumor dose in September 1955 (Fig. 30a) was 9000 rads in 39 days. Radiographic examination four months later (Fig. 30b) showed that the tumor was arrested but, more important, that there was no evidence of pneumonitis in the adjacent lung. This

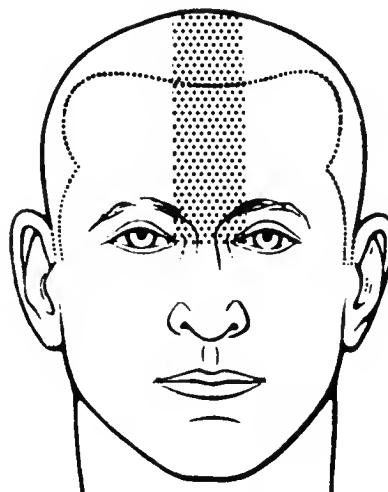
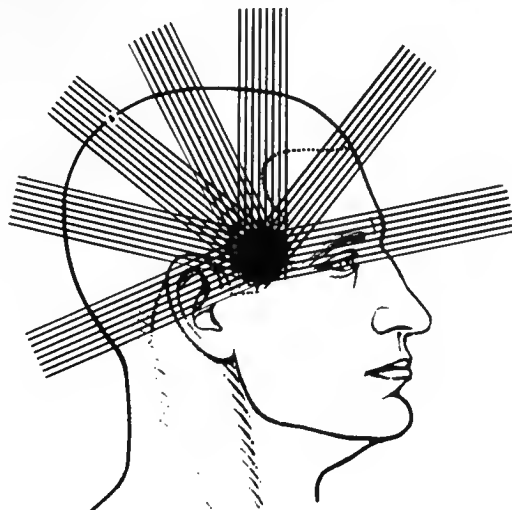

Fig. 29—Technique for supervoltage irradiation of a carcinoma of the ethmoid. The portal size was 4 by 4 cm. The skin dose of 3000 rads to each of seven portals delivered a tumor dose of 9000 rads.

case is excellent testimony to the efficiency of an irradiation technique when a well-collimated beam of supervoltage X rays is used.



(a)



(b)

Fig. 30—Extensive carcinoma of the esophagus with metastatic Virchow's node before (a) and after (b) treatment.

Summary

I have indicated the grave danger to normal tissues from moderate doses of supervoltage radiation. One must therefore exercise every possible ingenuity and

variation in technique to circumvent these dangers. It can be done, particularly with the aid of rotation techniques. One can therefore undertake the treatment of radioresistant tumors with large doses, accepting a reasonable but calculated risk of radiation injury.

Radiation Pneumonitis

CHAPTER 32

Harry L. Berman

Radiation Therapy Section
Walter Reed Army Hospital
Washington, D. C.

Abstract

Earlier investigators found that the lungs, when exposed to irradiation with a half-value layer (HVL) of the order of 1 to 2 mm of copper, were sensitive to tissue doses of 2500 to 3000 r in three to four weeks, with the resultant production of a radiation pneumonitis. The pathological, clinical, and roentgenological features of this condition were not readily correlated with dosage of irradiation, but the more severe changes developed when doses were in excess of that given above, when large volumes of lung tissue were irradiated, when irradiation was directed toward the mediastinum and hilar regions of the lungs as opposed to the peripheral zones, and when the patients had cardiac disease and arteriosclerosis.

A review of the pulmonary reactions to supervoltage irradiation (1000 kv, HVL 3.6 mm of lead) generally indicates that the causative factors and necessary precautions are similar to those established for the lower quality of irradiation. Under certain circumstances it may be possible to give tissue doses to the lungs of the order of 5000 r in five to six weeks without serious effects, especially in the treatment of lesions of the upper lobes and peripheral portions.

The possibility that irradiation may have harmful effects on the lungs has been known for some time. In 1940, Freid and Goldberg,¹ emphasizing clinical aspects, and Warren and Spencer,² stressing pathological features, reviewed the literature and comprehensively analyzed a number of cases in which there were pulmonary reactions to irradiation. From these studies certain notions evolved regarding radiation pneumonitis and the resulting pulmonary fibrosis. Among these were the following:

1. The lungs, as compared with other organs, are singularly susceptible to injury when exposed to tissue doses of 2500 to 3000 r in three to four weeks.

2. Roughly, the degree of damage varies directly with the magnitude of dosage and the volume of tissue irradiated.

3. Irradiation over the mediastinum and hilar regions predisposes to more serious effects than does that over the periphery of the lungs.

4. Damage is more marked in older patients with arteriosclerosis than in younger individuals.

5. There are wide, unpredictable variations in individual susceptibility and reactions.

6. Criteria permitting one to recognize and assess the extent of lung injury and its relation to the amount of irradiation administered are not well defined.

7. There may be a lag between the conclusion of a course of radiation therapy and the appearance of clinical signs of radiation pneumonitis. This means that, short of being unduly cautious, one cannot adjust a treatment program so as to stop at the earliest warning sign and thereby minimize the hazard.

The observations of the aforementioned authors were based on the use of X rays generated by 200- to 250-kv X-ray machines. It seems worth while at this time to review the subject of radiation pneumonitis in the light of our experiences with one million volt radiation. With increasing popularity and more widespread use of supervoltage equipment, there are trends toward higher dosage, perhaps an increase in the number of indications (both relatively and absolutely) for radiation therapy, and a willingness to accept some morbidity in return for effective cancer therapy.

I should like to illustrate some of the problems that may arise in connection with irradiation of tumors of the chest and some features of the inflammatory changes in the lungs which it may evoke. All the patients described were treated with a one million volt X-ray machine having an HVL of 3.6 mm of lead. The target-to-skin distance was 70 cm.

Case 1. This patient, a 47-year-old white woman, received postoperative X-ray treatment after a right radical mastectomy for carcinoma of the breast with axillary metastases. Treatment was as follows:

Period of treatment	Part treated	Site and size of treatment fields	Skin dose	Tumor dose
April and May 1954 (28 days)	Right axillary and supra-clavicular nodes	Opposing fields, 8 × 15 cm each	3750 r each	5100 r
May 1954 (22 days)	Right int. mammary nodes	Right parasternal, 5 × 15 cm	5300 r	4600 r

The superior portion of the right lung adjacent to the axillary nodes received a dose of 5100 r, and that part of the lung underlying the right parasternal field received a dose of 2500 to 3500 r, the anterior portion getting the higher amount. Chest radiographs at the

Case 2. A 63-year-old white woman resident of Texas developed a persistent, nonproductive cough in September 1953. A chest radiograph in December 1953 disclosed a rounded density in the mid-portion of each lung. The clinical impression was chronic



Fig. 1—Postirradiation fibrosis in right lung (case 1). Film was made two years after course of X-ray therapy. Note right pleurodiaphragmatic adhesion and densities (1) in right infraclavicular area where dose was 5100 r and (2) above right hilum where dose was 2500 to 3500 r.

conclusion of treatment, when a first-degree erythema of the skin of the treated areas was present, and again after a lapse of five months showed nothing remarkable. Two years after treatment (Fig. 1) the chest roentgenogram disclosed an irregular band of increased density along the medial portion of the right lung, linear densities in the right infraclavicular area, and a pleurodiaphragmatic adhesion in the right cardiophrenic angle. These are the most characteristic findings of pulmonary fibrosis. The patient had no complaints at any time referable to the respiratory system.

The volume of lung tissue damage was small, and there was no loss of respiratory function. The damage may therefore be regarded as insignificant (in the second patient the outcome was much more serious).

inflammatory disease, most likely coccidiomycosis, but the diagnosis was not confirmed.

The symptoms persisted, and the patient was admitted to Walter Reed Army Hospital in March 1955 for further study. Chest examination at this time (Fig. 2a) showed an increase in size of the lesions previously recognized plus a destructive area in the right eighth rib. A right thoracotomy and biopsy yielded a diagnosis of metastatic undifferentiated adenocarcinoma. A search for an active primary tumor was non-revealing. The patient had been successfully treated for an adenocarcinoma of the cervix uteri in 1944. This was subsequently considered to be the primary source; but initially the possibility was entertained that the lungs might be the primary site, and X-ray therapy was administered to the chest as follows:

RADIATION PNEUMONITIS

Period of treatment	Part treated	Treatment fields		Skin dose	Tumor dose
		Site	Size		
June 1955 (18 days)	Right mid-lung	Opposing fields (ant. and post.)	9 × 12 cm each	3200 r each	2900 r
June 1955 (18 days)	Left hilum	Opposing fields (ant. and post.)	9 × 6 cm each	3200 r each	3200 r
June 1955 (19 days)	Mediastinal nodes	Opposing fields (ant. and post.)	8 × 18 cm each	3200 r each	3200 r
July 1955 (21 days)	Right 8th rib (laterally)	Opposing fields (ant. and post.)	10 × 20 cm each	3200 r each	3200 r

A chest film (Fig. 2b) at the end of radiation therapy revealed diminution in size of the abnormal masses in the hilar regions. About a week after the course of irradiation was completed, the patient's temperature rose to 101 to 102° F. Two weeks later she began to have severe dyspnea and cyanosis, which became progressively worse. She deteriorated rapidly and died Aug. 27, 1955, four weeks after the course of irradiation was completed. The irradiated portion of the chest is shown in Fig. 2c.

previous surgery, and to arteriosclerosis. It was not possible to determine the quantitative responsibility for each factor.

The appearances of radiation-induced histological changes in the lungs are not pathognomonic. Our knowledge of these structural alterations is based on some excellent experimental and clinical work by a number of investigators, notably that of Engelstad,³ Warren,⁴ Warren and Spencer,² and Freid and Goldberg,¹ all of whom have been well reviewed in a fairly recent article by Bergman and Graham.⁵ With this information as a background, we can piece together a reasonably typical picture of the sequence of events that might follow the administration to the lungs of a commonly used tumor dose of 3000 to 4000 r in four to six weeks. The reaction in the affected portion of the lung will consist of four phases: (1) a localized hyperemia paralleling that in the skin of the treat-



Fig. 2a—Case 2. Preoperative chest film.

Histological study of the lungs after death (Fig. 2d) revealed thickening and fibrosis of the alveolar walls in the irradiated zone, compression and obliteration of some of the alveolar spaces, marked fibroblastic activity, a patchy round-cell infiltration, prominence of capillary endothelium and of the alveolar lining, and occasional bizarre cells. Some of these changes were undoubtedly secondary to the carcinoma, to the

ment field at about the third week of treatment; (2) a latent stage of three to six weeks after conclusion of treatment; (3) an acute inflammatory reaction lasting about four to eight weeks; and (4) the reparative process with marked fibroblastic proliferation extending over a period of several months.

The ensuing impairment of pulmonary function in any given patient will depend on the volume of lung

tissue involved, the severity of the inflammatory reaction, and the cardiac status of the individual. Severe and extensive reactions in the third or fourth phase, particularly if coupled with lung damage from other sources or cardiac disease, may lead to right-sided heart failure and death.

1945. Each lung successively received a tissue dose of 4000 r in 27 days, administered through opposing fields, each 15 by 23 cm. The metastases disappeared, and the patient had no respiratory complaints during the next (and final) four months of his life.

In this instance the acute reaction was mild, and the

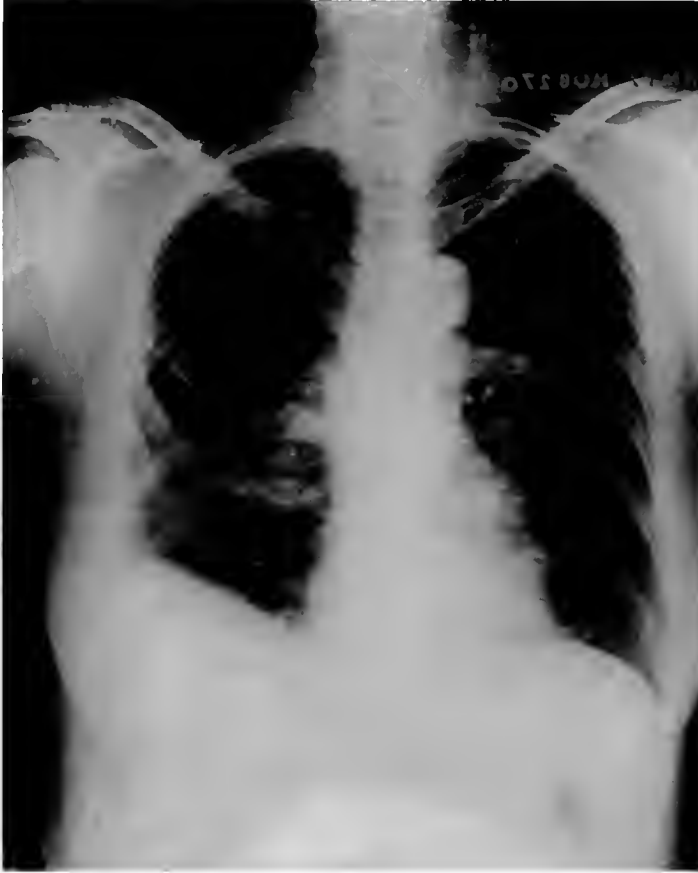

Fig. 2b—Case 2. Postirradiation film of chest. Tissue dose to irradiated lung and mediastinum was 2800 to 3200 r.

Although the tissue dose of irradiation in case 2 was not high and the volume of irradiated lung tissue was not unusually large, the inflammatory changes superimposed by the irradiation on already injured tissue exceeded the tolerance of the patient. The fatal termination came relatively early. Comparison of this patient with the first one brings out another important item, namely, that the damage was largely confined to the central portions of the lungs whereas in the first patient the peripheral parts were involved.

In the third patient marked pulmonary fibrosis following a large dose of irradiation to a considerable volume of both lungs and a relatively long postirradiation course is demonstrated.

Case 3. A 27-year-old white man, first seen at Walter Reed Army Hospital in February 1945 with a chondrosarcoma of the left ilium, developed numerous metastases in both lungs. He was treated with the one million volt X-ray machine during July to September

respiratory function was not seriously impaired, notwithstanding the size of the tissue dose of irradiation, the rapidity of its administration, and the volume of lung tissue irradiated. The post-mortem histological examination of the lungs showed thickening of the alveolar walls with minimal fibroblastic activity (Fig. 3). The pathological changes were far less severe than those of the previous patient and apparently had no deleterious effects on the gaseous exchange in the alveoli and capillaries.

In the fourth case the combination of severe lung damage, high radiation dosage, large volume of irradiated lung tissue, a relatively long postirradiation course, and a fatal termination is demonstrated.

Case 4. This patient, a 68-year-old white woman with arteriosclerotic heart disease and diabetes, received irradiation with one million volt X rays in August 1946 for a squamous-cell carcinoma of the

middle third of the esophagus. Treatment was given through two anterior and two posterior mediastinal fields, each 6 by 13 cm, with the beam angled toward the esophagus. The tumor dose was 4300 r in 31 days. Each field received a skin dose of 2500 r.

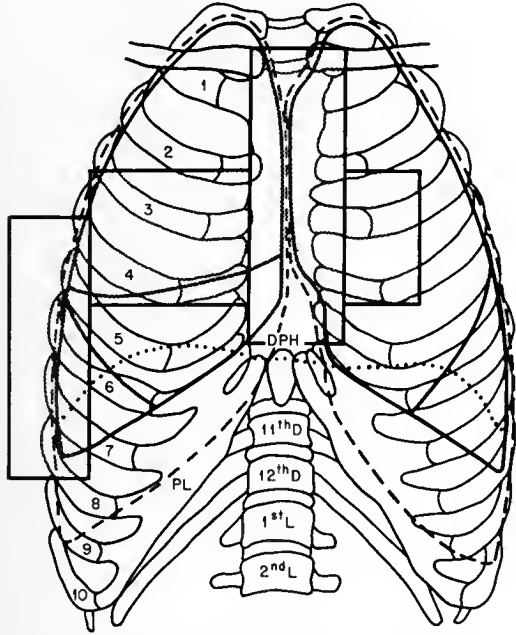

Fig. 2c—Case 2. Irradiated portion of the chest.

In May 1947, a second course of X-ray therapy was given for a suspected recurrence. A tumor dose of 4000 r in 22 days was delivered through opposing anterior and posterior mediastinal fields, each 12 by 20 cm. About two months later, cough, dyspnea, weakness, and fever developed, which were considered to be due to postirradiation pneumonitis. A chest radiograph (Fig. 4) at this time demonstrated a rectangular shadow of increased density corresponding to the location of the treatment fields and was considered to represent pulmonary fibrosis. The patient's condition gradually became worse, symptoms of cardiac failure developed, and the patient died six months after the second course of irradiation (December 1947).

Findings at autopsy included a severe bilateral pulmonary fibrosis, atelectasis of the lower lobes of both lungs, generalized arteriosclerosis, arteriosclerotic heart disease, residual carcinoma of the esophagus with pulmonary and right supraclavicular node metastases, in addition to aortic thrombosis, and a cerebral embolism.

The high dose of irradiation spread over a relatively large volume of lung tissue was poorly tolerated because of the presence of coexisting cardiac, vascular, and neoplastic disease, all of which tend to provoke inflammatory reactions, fibrosis, and reduced vascularity and thereby to affect pulmonary function adversely. Another critical item was the involvement of the central portions of the lungs. A similar roent-

gen pattern is seen in the next patient, but in this instance the effect was far less devastating.

Case 5. A 25-year-old white man with Hodgkin's disease received irradiation with the one million volt X rays to the mediastinal and hilar nodes in September and October 1954, through opposing anterior and posterior mediastinal fields, each 12 by 15 cm. The tumor dose was 2400 r in 36 days. A chest radiograph made one month later was not remarkable, but three months after that, in February 1955 (Fig. 5), a chest roentgenogram disclosed a rectangular density outlining the treatment field and representing pulmonary and mediastinal fibrosis. The patient had no complaints referable to the respiratory system. In May 1955, the patient died of disseminated Hodgkin's disease. There was no gross evidence of fibrosis in the lungs or mediastinum at autopsy.

The last two patients, for whom there were similar roentgenographic findings—one following a tumor dose to an esophageal carcinoma of 8300 r in two courses over a period of 10 months and the other after a tumor dose of 2400 r in 36 days to Hodgkin's disease of the mediastinum—illustrate the difficulty one may encounter in attempting to evaluate the roentgen appearance of radiation fibrosis and its correlation with dosage.

In all the patients discussed so far, the factor of lung injury was not anticipated to be a critical item in the planning stages of radiation therapy. In cases 2 and 4, in which pulmonary damage following irradiation was directly related to the patients' deaths, it was felt that the likelihood of severe radiation injury to the lungs was remote.

The indications for irradiation therapy, however, sometimes require that a calculated risk be taken and that treatment be given despite the realization that significant postirradiation lung injury is a strong possibility. This is exemplified in the next two patients.

Case 6. The first of these patients was a 23-year-old white man with an inoperable neuroblastoma of the left hemithorax, which had been proved by biopsy. The lesion was extremely radiosensitive but tended to recur periodically in the left hemithorax. The location of the various tumors in the left hemithorax and corresponding tumor doses given during X-ray therapy are shown in Fig. 6.

The frequent recurrences necessitated repeated exposure of the left lung to irradiation. Due cognizance was taken of the possibility of injury to the left lung, but the extreme radiosensitivity of the tumor, the lack of any alternate method of therapy, the recurring hope that one more course of treatment would control the disease, and the maintenance of good pulmonary function over a relatively long period of time led us to feel that the risk was worth while. It is difficult to determine the dosage distribution throughout the left lung since the radiation was not delivered uniformly to all parts. A reasonable estimate is that, over a period of about 18 months, in which this tumor ran its course from diagnosis to death of patient, the upper

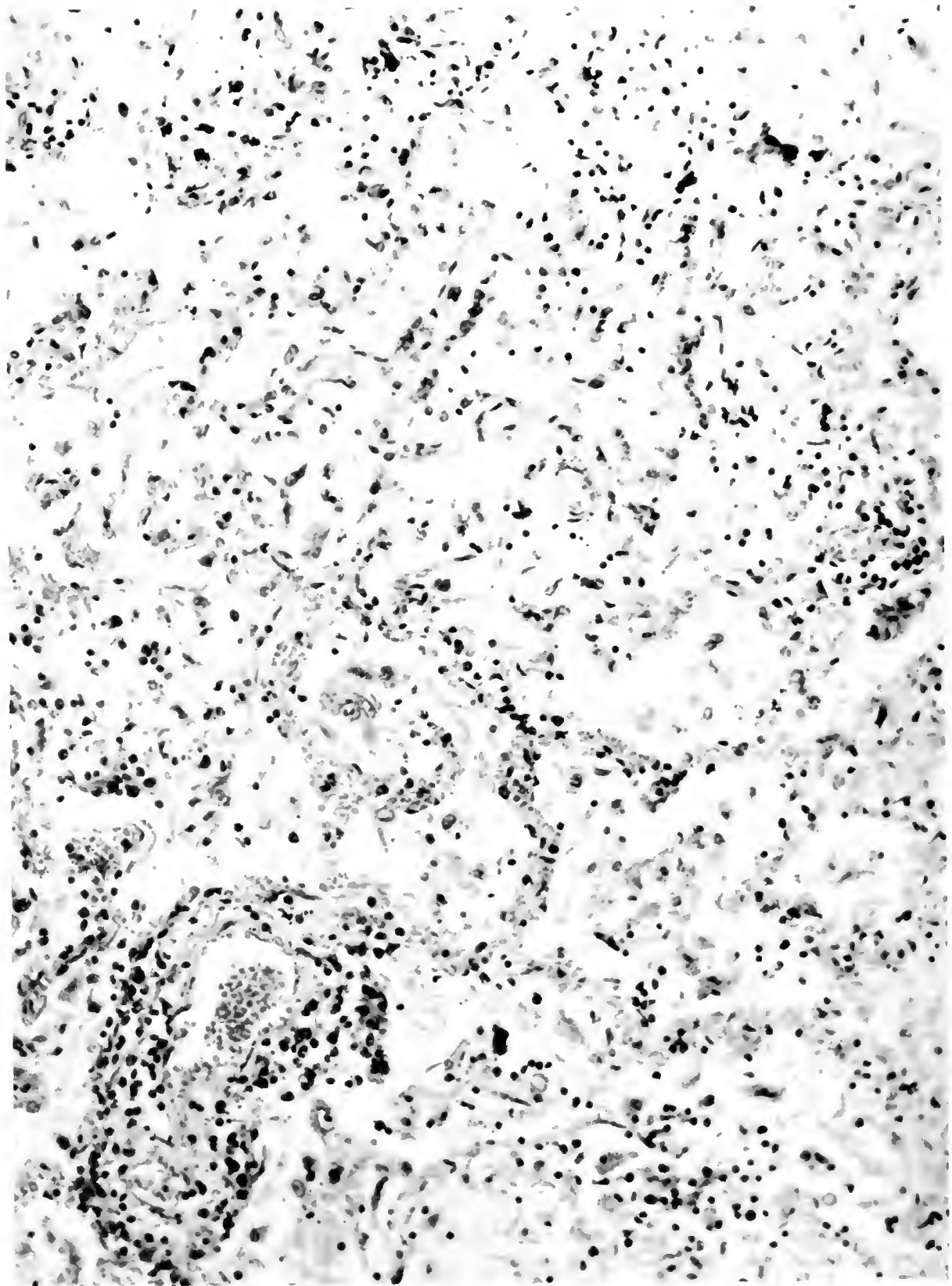

Fig. 2d— Case 2. Microscopic appearance of irradiated lung, showing intense inflammatory reaction. (110 \times)

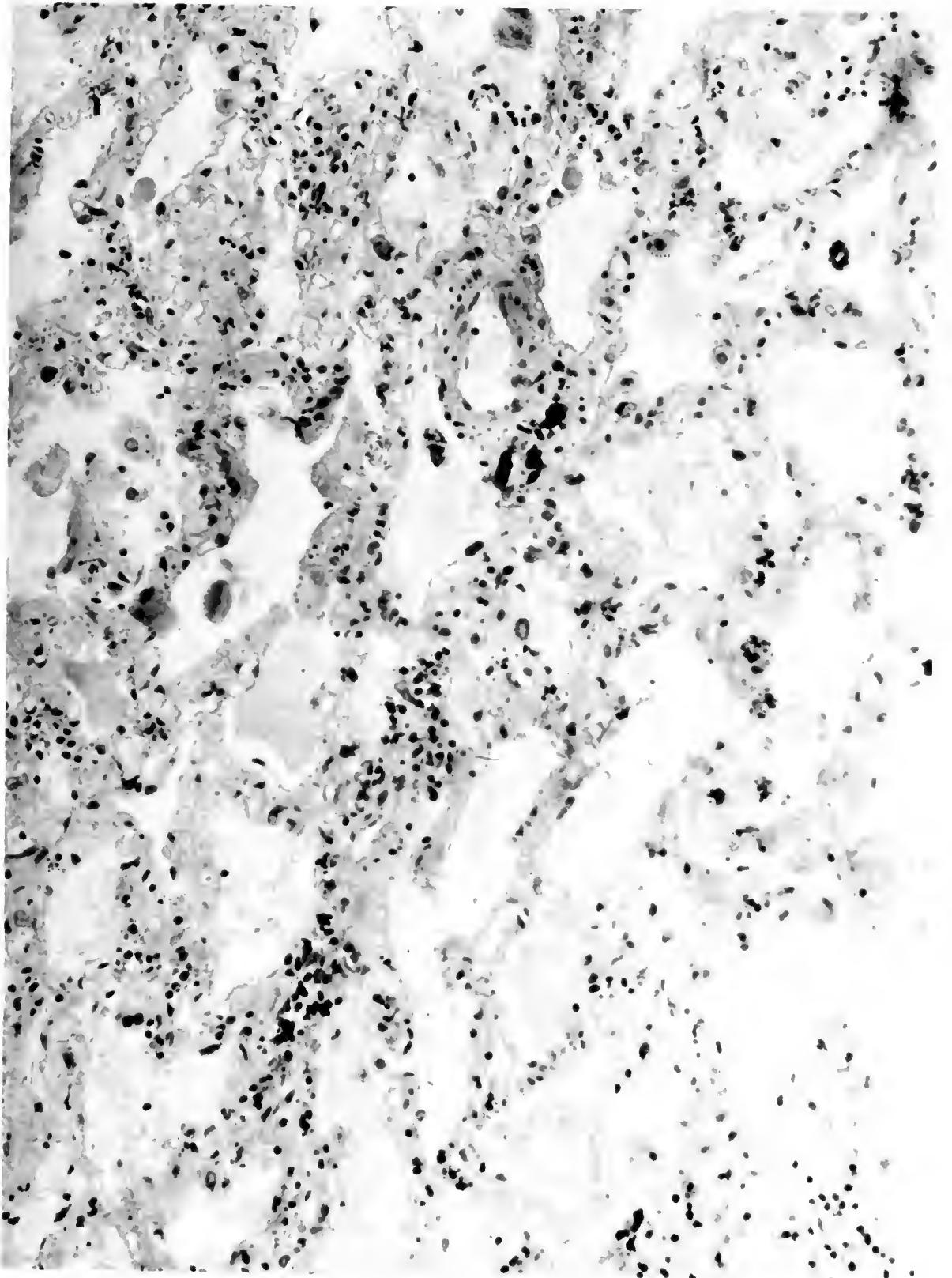

Fig. 3— Microscopic appearance of irradiated lung in case 3, showing thickened alveolar septa. Dose to lung was 4000 r. (110 \times)

half of the left lung in places received as much as 7900 r and the lower half had about 4000 to 4700 r.

At the time of the patient's final admission to the hospital two weeks before death, he had skeletal metas-

ment (Fig. 7). At autopsy the left lung was completely fibrosed, inextricably intermingled with tumor, and densely adherent to the chest wall and mediastinum. The heart was pulled to the left, and its displacement



Fig. 4— Postirradiation fibrosis in case 4 following treatment for carcinoma of the esophagus with a tumor dose of 8300 r.

tases and complained of dyspnea, which rapidly became severe. The chest radiograph at this time disclosed shrinkage of the left hemithorax, considerable loss of aeration of the left lung, and cardiac enlarge-

ment had produced a sharp angulation of the inferior vena cava. A pericardial effusion was present.

Case 7. The next patient was a 54-year-old white

man admitted to Walter Reed Army Hospital in April 1948 with the complaint of a cough that had persisted for five months. A chest film at about this time showed an area of increased density in the left upper

with one million volt X rays to the left upper hemithorax in April, May, and June of 1948. Two opposing fields, each 15 by 15 cm, were used, and a tumor dose of 8000 r in six weeks was delivered.



Fig. 5— Postirradiation fibrosis in case 5 following treatment for enlarged mediastinal nodes in Hodgkin's disease with a tumor dose of 2400 r.

lobe. The diagnosis, proved by thoracotomy and biopsy, was inoperable undifferentiated bronchogenic carcinoma involving the left upper lobe and adjacent pleura. The patient received postoperative irradiation

The patient is alive and well today—eight years later. A recent film (Fig. 8) disclosed the diffuse fibrosis of the upper half of the left lung and the shrinkage of the upper left hemithorax, all of which are well

tolerated by the patient. Fibrosis in the upper lobes is less likely to produce crippling symptoms than that elsewhere in the lungs. The treatment of lesions involving irradiation of the upper lobes, especially bron-

chogenic carcinoma, may be undertaken, therefore, with relatively larger doses than those used in other parts of the lungs.

Where known radiation fibrosis of the lung is present, further irradiation to the affected area would appear to be contraindicated. However, there are times when differentiation between radiation fibrosis and recurrent malignancy is difficult. Both conditions may be present simultaneously, and the question of reirradiation may arise, as shown in the next patient.

Case 8. This patient, a white man, was first treated for Hodgkin's disease in January and February of 1946 at the age of 21. He received irradiation to a mediastinal mass through opposing anterior and posterior fields, each 15 by 15 cm, with one million volt X rays. A tumor dose of 3850 r in 30 days was delivered. Subsequent chest films disclosed evidence of radiation fibrosis corresponding to the treatment fields, although the patient remained free of symptoms for over nine years.

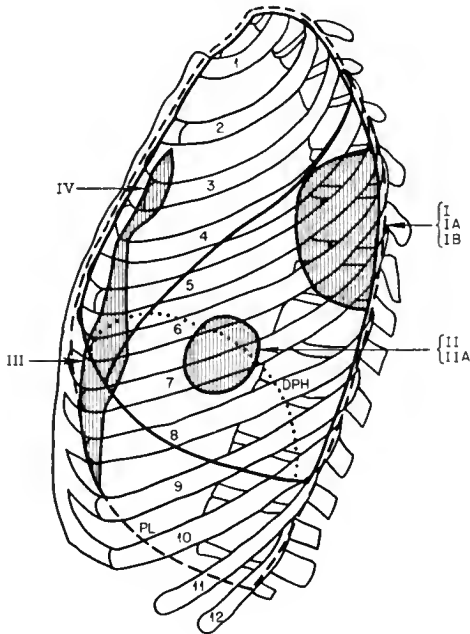

Time of X-ray therapy	Tumor	Tumor dose, r
January 1953	I	3200
May 1954	IA*	2700
June 1954	IB*	2000
	Total	7900
January 1954	II	3100
June 1954	IIA*	1680
	Total	4780
October 1954	III	4000
March 1955	IV	4000

*Recurrence.

Fig. 6—Case 6. Location of tumors in left hemithorax with summary of X-ray therapy.

Discussion

The experiences with one million volt X rays herein described generally duplicate those with radiation of lower qualities. However, these are selected cases. Considering the large number of patients with tumors of the chest who receive irradiation, those with severe reactions are the exception rather than the rule. As a matter of fact, the vast majority of patients tolerate tissue doses to the lungs of 3000 to 5000 r in four to six weeks, respectively.

Radiologists, as a rule, plan their treatment programs to avoid haphazard irradiation of the lungs, a practice with which I am in accord. Generally, the indications for radiation therapy are more compelling than are those for undue precautions to protect the lungs. Obviously, it is impossible to irradiate a tumor of the chest and miss the lungs entirely. We know that the destruction of some tumors is impossible because the required dose or the volume of exposed normal tissue is excessive when compared to the tolerance of the patients. However, excepting this group, there are many patients for whom there is no treatment other than irradiation. Although radiation pneumonitis and pulmonary fibrosis remain a threat to some in spite of all precautions, this complication in most instances will not be serious, even with tumor doses of the order of 5000 r appropriately fractionated and judiciously delivered. In the upper lobes it may be possible to administer a tumor dose as high as 7000 r in six to seven weeks. Obviously, the magnitude of dosage will be governed by the volume of lung tissue



Fig. 7 — Postirradiation fibrosis of left lung in case 6 following repeated courses of treatment for a neuroblastoma over a period of two and one-half years.



Fig. 8 — Postirradiation fibrosis of upper left lung in case 7, seven and one-half years after treatment for bronchogenic carcinoma with a tumor dose of 8000 r.

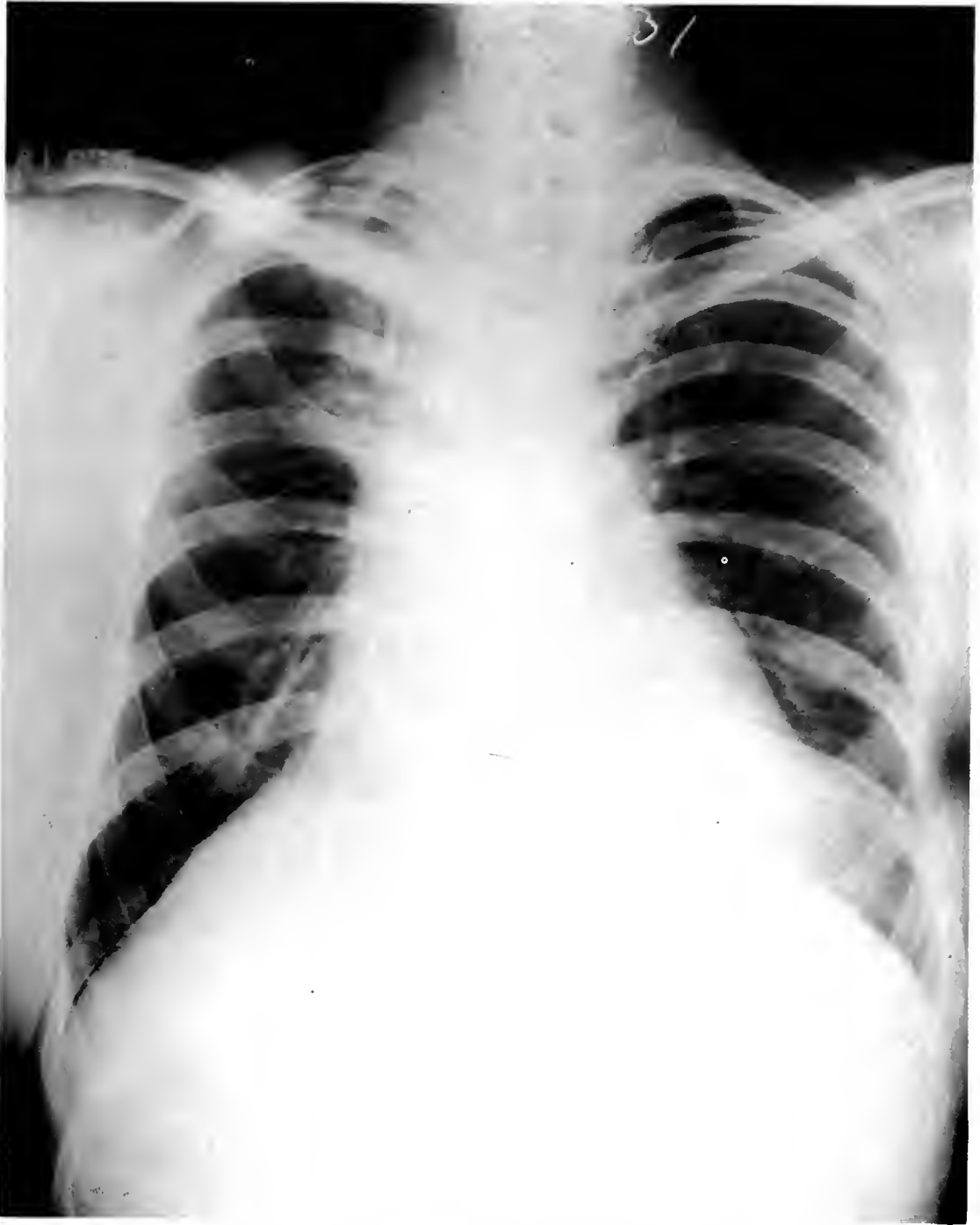

Fig. 9— Postirradiation fibrosis in case 8 following repeated courses of treatment to mediastinum for Hodgkin's disease with a total tumor dose of 8100 r over a period of 10 years.

irradiated and by the patient's cardiac and pulmonary status.

Among the positive measures for the prevention and control of radiation fibrosis, the use of cortisone is most prominent. Its value is hard to assess chiefly because no one knows just what the incidence of radiation pneumonitis is and what patients are likely to suffer from this complication. Warren and Spencer² reported that 12 per cent of their series of 234 irradiated patients had pulmonary reactions; and Chu, Phillips, Nickson, and McPhee⁶ claimed a probable incidence of radiation pneumonitis of 60 per cent with direct portal technique of postmastectomy irradiation. Engelstad⁷ reported an incidence of pulmonary reactions in 5.4 per cent of 386 cases of breast cancer and in 20.4 per cent of 49 cases of carcinoma of the esophagus. He stated that there were no fatal reactions. However, Whitfield, Lannigan, and Bond⁸ claimed that three of their patients died from pulmonary irradiation damage, and, in the three fatal cases described herein, the irradiation of the lungs was at least an important contributory factor to the patients' deaths. A careful, controlled study of the value of cortisone is still to be performed.

A rather novel form of treatment was suggested by Bergman and Graham,⁵ who successfully performed pneumonectomy in two cases of severe irradiation damage. They point out that patients with clinical evidence of pulmonary radiation fibrosis have dyspnea despite any physiologic need for hyperventilation. They feel that abnormal reflexes originating in the affected lung cause hyperventilation and dyspnea and that pneumonectomy removes the etiological factor. This form of therapy likewise requires further evaluation.

Conclusions

1. The clinical, roentgenological, and pathological features of pulmonary reactions to supervoltage irradiation of the chest have been discussed.

2. It is difficult to correlate these features with each other and with radiation dosage, except with extremely high doses (8000 r as an example), and to anticipate the development of disabling sequelae.

3. It is felt that serious, unfavorable reactions to supervoltage irradiation of the chest with tissue doses as high as 5000 r in five to six weeks are uncommon, but due consideration must be given to the volume and location of lung tissue being irradiated and to the patient's cardiac and pulmonary status.

4. The upper lobes and peripheral zones tolerate higher doses of irradiation than do the other parts of the lungs.

References

1. J. R. Freid and H. Goldberg, Post-irradiation Changes in the Lungs and Thorax, *Am. J. Roentgenol. Radium Therapy*, 43: 877-895 (June 1940).
2. S. Warren and J. Spencer, Radiation Reaction in the Lung, *Am. J. Roentgenol. Radium Therapy*, 43: 682-701 (May 1940).
3. R. B. Engelstad, Über die wirkungen der roentgenstrahlen auf die lungen, *Acta Radiol. Suppl.*, 19: 1-94 (1934).
4. S. Warren, Effect of Radiation of Normal Tissues. V. Effects on the Respiratory System, *Arch. Pathol.*, 34: 917-931 (November 1942).
5. M. Bergman and E. A. Graham, Pneumonectomy for Severe Irradiation Damage of the Lung, *J. Thoracic Surg.*, 22: 549-567 (December 1951).
6. F. C. H. Chu, R. Phillips, J. J. Nickson, and J. G. McPhee, Pneumonitis Following Radiation Therapy of Cancer of the Breast by Tangential Technique, *Radiology*, 64: 642-654 (May 1955).
7. R. B. Engelstad, Pulmonary Lesions After Roentgen and Radium Irradiation, *Am. J. Roentgenol. Radium Therapy*, 43: 676-681 (May 1940).
8. A. G. W. Whitfield, R. Lannigan, and W. H. Bond, Fatal Post-irradiation Pneumonitis, *Lancet*, 267: 117-119 (July 17, 1954).

DISCUSSION

CHAPTER 33

Ridings: Perhaps at the expense of compounding repetition, it should be pointed out that there is one thread that can be traced unbroken throughout this entire meeting, namely, the problem of injury to normal tissues and methods of limiting this injury. The importance of this has been well outlined, but solutions to the problem are incomplete.

One item, brought out by Dr. Farmer, is that we must not confuse integral dose with localized overdosage to normal tissues. With strategically placed multiple fixed fields, one may achieve a smaller integral dose than with rotational therapy; but in rotational therapy it is easier to avoid localized overdosage to normal tissues. These considerations might occasionally operate as indications for or against the use of rotational therapy.

I have a few questions regarding specific organ systems. Dr. Friedman's comments concerning late effects of supervoltage irradiation on abdominal muscles make us wonder whether we should again start taking the heart into consideration in laying out chest fields for supervoltage irradiation. Do we have any data on this?

I should like to make one general comment about normal tissue tolerance and reaction. Our information on the effects of radiation is, at best, a series of islands of information rather than a whole body. We have, on the one side, radiation physics; in the center, radiopathology and cellular biology; and, on the other side, clinical effects observed on the individual as a whole. It would be desirable to have available data that would tie these islands together. If this were possible, we might be able to devise formulas allowing us to predict treatment phenomena. However, tissues do not conform exactly to known formulas, and usually a careful correlation of clinical observations, admittedly inexact, give the most reliable answers. I hope not to be accused of undue pessimism or of impertinence, but I should like to suggest that the practical answers concerning the relative sensitivity of tissues (normal or otherwise)

to supervoltage vs. conventional therapy rest not upon a base of physical equations (however extensive that base might be) but rather upon a system of clinical observations.

This then suggests that we look to an example set primarily by the best of the early schools of radiotherapy: accumulation of large numbers of comparative cases meticulously observed. Correlation and integration of these observations will yield concepts that are meaningful and applicable.

Rubinfeld: I have a comment about Dr. Berman's paper; I was confused by the terms pneumonitis and fibrosis. Pneumonitis is probably a constant concomitant of every lung treated with X radiation. The characteristic histologic picture demonstrated by Shields Warren shows vascular injection, fibroblast proliferation, and extravasation of red cells and lymphocytes in the stroma. This is a transient process. Fibrosis, consisting of thickened stroma with dense fibroblastic proliferation, appears in a small percentage of irradiated lungs. The time of its radiographic appearance cannot be predicted. The complete disappearance of pneumonitis or fibrosis (probably pneumonitis), which was illustrated in a case of breast cancer, is a phenomenon that occurs frequently.

The risk of producing fibrosis is justified in the treatment of some diseases. For instance, a patient with cancer of the lung will probably die within the year. Therefore the risk of fibrosis is permissible if other benefits are thereby achieved. However, treatment of a cancer of the breast does not justify the risk of fibrosis. Thus the glancing technique, which delivers an adequate dose to the superficial cancer-bearing zone while sparing the deeper lung, is desirable.

Treatment of the lymphomas often introduces the problem of lung reaction. We must ask ourselves, as exemplified in the case of Hodgkin's disease that was presented, whether we are correct in utilizing a technique that will produce a pneumonitis to be fol-

lowed by fibrosis. My experience has taught the avoidance of such techniques in treating lymphomas.

I have had some experience with cortisone as an agent to prevent the occurrence of pneumonitis or fibrosis or both. The original enthusiasm, when all lung cancers receiving radiation were given cortisone in 100-mg doses, has been deflated. Two patients, one with a lung cancer and the other with esophageal cancer, had sudden massive hemorrhages followed by rapid death during the latter part of the X-ray treatment cycle that included cortisone.

Friedman: For the lack of time, I shall not discuss all the points raised, but I should like to re-emphasize one important feature: the enormous individual variation in late radiation injuries.

Concerning early reactions during irradiation, there is ± 20 per cent individual variation. The individual variation for early postirradiation injuries is somewhat greater, but for late irradiation injuries it is enormous. Consequently it is difficult to quantitate the probable frequency of these injuries.

Concerning age vs. lung injury, the preceding com-

ment is particularly pertinent. As far as the influence of age on irradiation injuries of the cord is concerned, the same comment applies.

The dose for castration of the ovary will take at least 15 minutes to discuss and consequently will not be discussed.

It is well known that the perineum is exquisitely radiosensitive. The vulvar skin will exhibit second-degree epidermitis with doses of 2000 r and sometimes less.

Local injury following irradiation for carcinoma of the urethra should not be a deterrent against irradiating the lesion with a direct intravaginal cone or interstitial radium. It is an acceptable calculated risk in exchange for possible cure.

Concerning the question of the tolerance of the rectum raised by Dr. Rubinfeld, my comments were applicable only to external irradiation with 200 kv or supervoltage irradiation. The interesting feature is that the rectum can tolerate twice the dose that the rest of the gastrointestinal tract can. By the word "tolerate," I mean that the tissues escape serious irradiation damage.

Irradiation of Metastases

CHAPTER 34

Douglas Quick

Janeway Clinic
Roosevelt Hospital
New York, New York

I assure you I am reasonably harmless; I have almost no isodose curves to present, and I have no super-velocity crossword puzzles, either rotating or stationary. When I first read the title assigned me, it sounded a little like setting up a program in general farming. It is somewhat like general farming because, once a patient is diagnosed as having metastases, he had better be allocated to the hospital service best suited for his treatment. This can cover a wide field. We should think of the factors that might influence our decisions on what quality of radiation to use or on whether any radiation should be used:

1. The most outstanding factor probably should be whether the metastatic disease is localized or disseminated.

2. We should also know something about the condition of the primary growth. Has it been arrested, or is it still uncontrolled?

3. The tissue of origin certainly has a bearing on our decision since it does affect such things as radiosensitivity and rate of growth.

4. The histology of the tumor affects our decision. Is it an anaplastic or a well-differentiated tumor? The histology is related to a terminology that has been misleadingly used for many years. Is the tumor radio-sensitive or radioresistant? It appears that the terms are usually used to denote an opinion that either a large dose or a small dose of radiation is necessary to destroy the tumor. The so-called "radioresistant" (or, histologically, more differentiated) tumors, once they are controlled (without irreparable damage to normal tissues), seem to have better long-term results.

5. The type of metastatic involvement affects our decisions regarding therapy. If it is a lymph-node involvement, is it a single lymph node, multiple lymph nodes in one field, or multiple fields of lymph nodes? If the metastasis is located only in the soft parts, the decision might be different from what it would be if it were only in bone. If the involvement is very wide-

spread, of the nature of blood-borne metastases, our enthusiasm is dampened for any kind of treatment.

6. The age and general condition of the patient is a real factor in the choice of modes of therapy.

7. A very important question always arises. Are there any particular features that might encourage the therapist to gamble a little? Does it look worth while to attempt to stretch the reasoning a point or two? Is there any possibility of getting a better result than ordinarily anticipated?

8. A question that must always be asked is, "Is the case one for possible cure?" By cure I mean the complete control of the disease so that the patient might presumably live beyond the five-year period. If we cannot talk in terms of cure, then we must ask, "Is the patient a possible candidate for long-term palliation, or, as is more likely, are we thinking only of short-term palliation?"

When we have answered all these questions, I do not think we have solved the problem of therapy; but these are the factors that should help us determine just what kind of program is to be used. If radiation is to be considered, these factors help us determine the quality of radiation to be allocated to the patient. Many other influences govern a decision on therapy. Some lesions, in our present state of knowledge (and even diplomacy enters into consideration), should be allocated directly to surgery. Some should be allocated to surgery plus radon. Some lesions should have radium-element needle transfixion, cobalt needles, gold implants, or radioactive gold in nylon or polyethylene tubing. Any other kind of interstitial irradiation might be appropriate. Each modality is better for some lesions than it is for others.

I say that some of the lesions should be allocated directly to surgery. As an example, I think particularly in terms of head and neck cancer. A well-differentiated epidermoid primary tumor in the mouth which is well on the way to control might have a single encapsulated metastatic node on one side of the neck.

This kind of patient should have not a "toy" neck dissection but a complete neck dissection. On the other hand, if the involvement is bilateral or if the tumor has perforated the capsule of the node, then we are justified in calling this an "inoperable neck." This kind of patient should be treated with radiation, not with surgery. Under some circumstances a more accurate irradiation can be done when coupled with surgical exposure.

Another group of lesions—call them recurrent or metastatic—should be repeatedly sent back to surgery, e.g., recurrent cancer in the abdomen. On the other hand, a few of these—the embryonal tumors of gonadal origin—are best treated with radiation. For the most part, tumors of the bowel are not well treated with radiation. We often think that we shall try just this one more case with radiation, forgetting that most recurrent or metastatic masses in the abdomen have bowel attached to them. Damage to the bowel most often occurs before we have seriously influenced the tumor. I should suggest leaving these patients with the doctors who are willing to operate as long as the patient can stand another anesthetic.

Further down into the pelvis are the growths that involve the female pelvic organs. Some growths are recurrent in the parametrium; some are metastatic to the lateral pelvic wall. These seem to be excellent choices for treatment with supervoltage radiation.

One of the early patients treated with our radium-beam unit was a woman who had a carcinoma of the cervix. Her primary tumor was treated with radium improperly applied. The visible lesion was healed, but a few months later there was a large fixed mass in the left pelvis. The patient had a swollen leg, and pain was radiating down it. This was a typical picture following improper therapy. Four years later, after treatment of the metastasis with our radium-beam unit, the patient is in very good condition. She has no swelling or pain and is quite happy.

General Medical Care

A large group of early metastatic lesions, if localized and treated, offer a chance for cure or long-term palliation. However, in addition to whatever supervoltage equipment is being used, the patient should have "everything." He should have the best effort the radiologist as a physician can offer. General medical care should be kept at a top level from the beginning of treatment. I use crude liver extract, B complex and B₁₂, in large doses. In addition, certain cases are influenced by specific hormonal medications.

I am strictly against one type of supporting medication. This is the use of toxic chemicals, such as nitrogen mustard, TEM., and that sort of thing. Toxic medication should be used only for special research. Special considerations should determine that toxic chemicals are to be used. Usually they should be used only as an eleventh-hour effort under the conditions of a special decision.

Many patients are nauseated after radiation, but often this nausea is unnecessary. Some kind of sup-

porting therapy in rather generous doses should be started at the beginning of therapy. I use Thorazine and pyridoxine, but every physician should use whatever he has most faith in.

Special Types of Radiation Therapy

Time does not permit me to specify all the special cases that require treatment other than external radiation. For example, a few cases of thyroid carcinoma have a favorable differential uptake of I¹³¹. These are being treated with a kind of supervoltage radiation.

There is another situation that I think deserves comment. This is in the treatment of hyperthyroidism. I think there is too much hypothyroidism being created with radiation and that this is due to our not being conservative and cautious enough. Unnecessary damage is being done with the therapy for hyperthyroidism.

There are some exceptions to our general rules for allocating patients to supervoltage therapy. An example is the young subject in good general condition who has a disease disseminated more than would ordinarily be desirable for supervoltage radiation. Yet, if this person carries a special appeal or unusual responsibilities, an exception can be made. At the other end of the range is the other type patient who has a fairly localized condition but has an underlying disease already out of control.

The exceptions are often more interesting than the cases that follow the rule. I am thinking at this moment of a man who was sent to me several months ago. He had an incompletely treated cancer of the base of the tongue and a mass in the neck. This neck mass was increasing rather rapidly. A survey of his chest showed multiple bilateral metastases. If this patient were left alone to go home and sun himself on his porch, the neck lesion would most likely break down and result in a nasty open wound long before his chest would produce symptoms. His primary growth at the base of the tongue would probably cause him to be miserable before his metastases caused trouble. With all these discouraging signs we still irradiated the patient. Six months later he wrote to me, stating that he had gained some weight; he was feeling comfortable; he could swallow well; and his neck lesion did not bother him. We did not prolong this patient's life, but we did make him more comfortable while he was alive. In my judgment the prolongation of life without relief of symptoms is rarely worth while, but the relief of symptoms even where life cannot be prolonged usually is.

Many other kinds of therapy should be considered. For example, we should discuss Professor Smithers's double-barreled under-and-over automatic with radiogold seeds in it. I think it is a fine device. For myself, however, I use a single-barreled muzzle-loading trocar needle with a radon seed in the end.

There is a question in my mind about the use of radioactive gold fluid injected into nonencapsulated tumor-bearing areas. I feel that some of us are running a little bit wild and that we are using an agent

susceptible to poor control where a better agent is available.

Just lately I questioned many of the candidates under examination by the American Board of Radiology on the use of radioactive gold in the pleural and peritoneal cavities. I was struck by the rather uniform

water has remained clear for four and one-half years. Figure 2 illustrates the apparatus as it is seen on coming around the corner from the maze into the main treatment room. A hydraulic table is used for adjusting the patient to the proper height. Figure 3 shows the electrically controlled beam head. This beam head

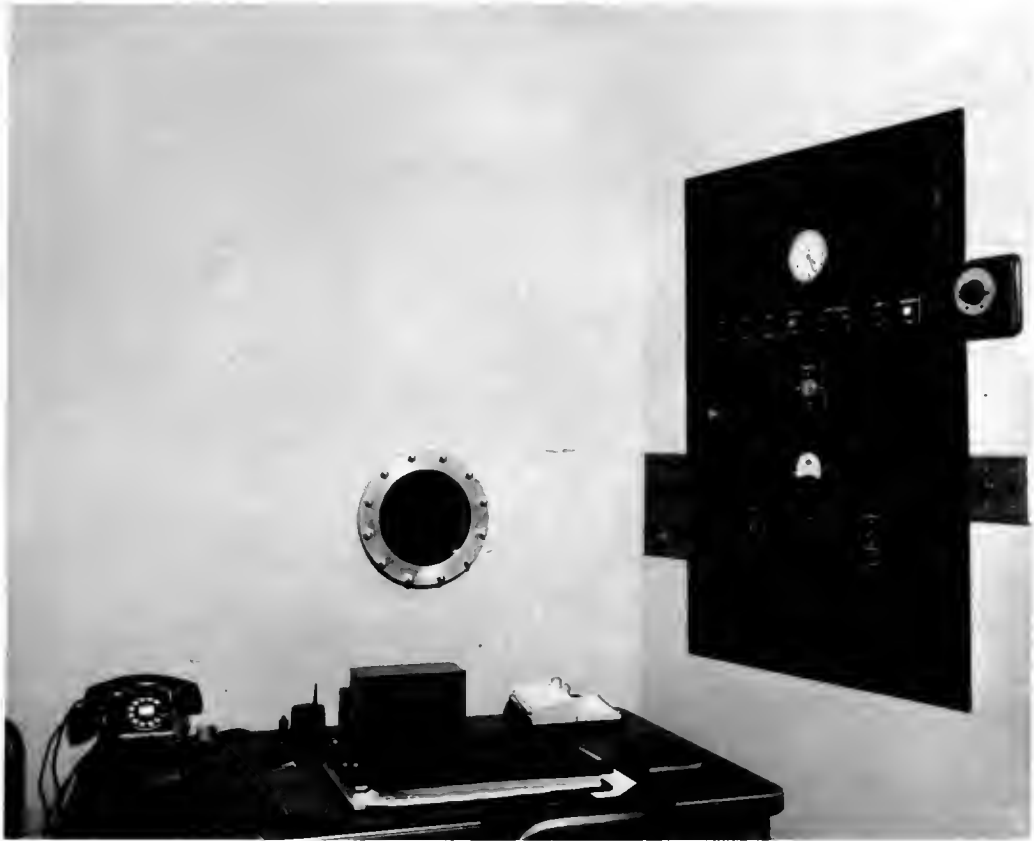

Fig. 1—Control panel, showing switches for moving radium ring, water window for observation of patient through concrete wall 2 ft thick, and speaking system for communication with patient.

answer that indicated a trend away from the use of radioactive gold back toward the use of nitrogen mustard. This was disturbing to me. The use of radioactive gold is an example of a very likely isotope for a well-conceived purpose. Is there some technical or administrative problem with Au^{198} which causes it to be replaced by a toxic chemical?

The choice of supervoltage or gamma-beam source is a matter of individual decision. It depends upon what is available. I personally use a radium-beam unit because that is what I have to work with.

The Fifty-gram Radium-beam Unit

I should like to describe our supervoltage radiation source. Figure 1 shows the control panel. I selected this picture particularly to show the simplicity of the design. For our viewing port we use a stainless-steel cylinder shaped like a cone. It is made very simply of plate-glass windows and is filled with water. This

can be moved back and forth on supporting I-beams; however, for a good while I have not moved the beam head at all but have kept it in a fixed position. The beam head can be angled to slightly more than 90 deg in either direction from the vertical position. The usual gadgetry for positioning the beam and the patient are available.

Figure 4 is a scale drawing of the beam head. The mercury pool—about 850 to 900 lb of mercury—is shown inside the lead jacket. When the beam is in an inactive position, the circular steel ring carrying the radium capsules rises to the top of the mercury pool. There are 25 radium capsules in the ring.

The radium moves from inactive position (11) down to active position (5). Each capsule comes in accurate apposition with the opening of its particular channel to the outside world. Each channel is set at 23 deg to the vertical. The result is a stationary multiple-beam arrangement, with 25 beams shooting downward and inward to one focal spot.

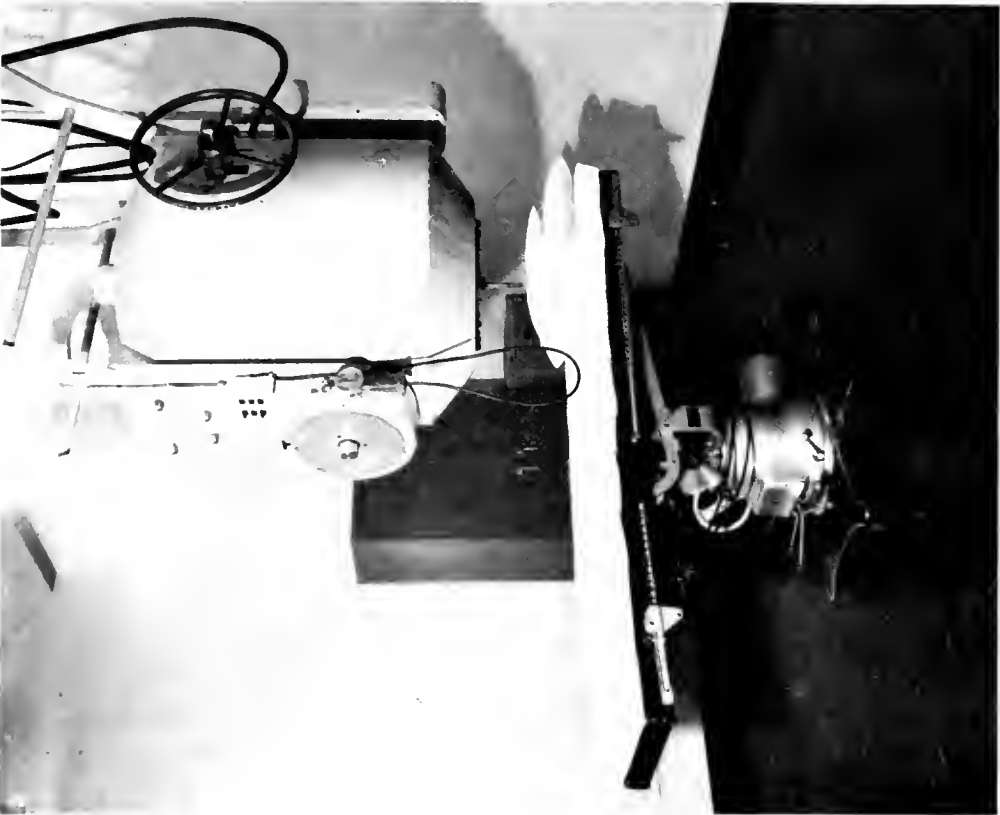

Fig. 2—Radium-beam unit as it appears to patient entering the room from the maze. Dial for determining angulation of beam head and emergency wheel for manually raising radium into safe position in case of power failure are shown.

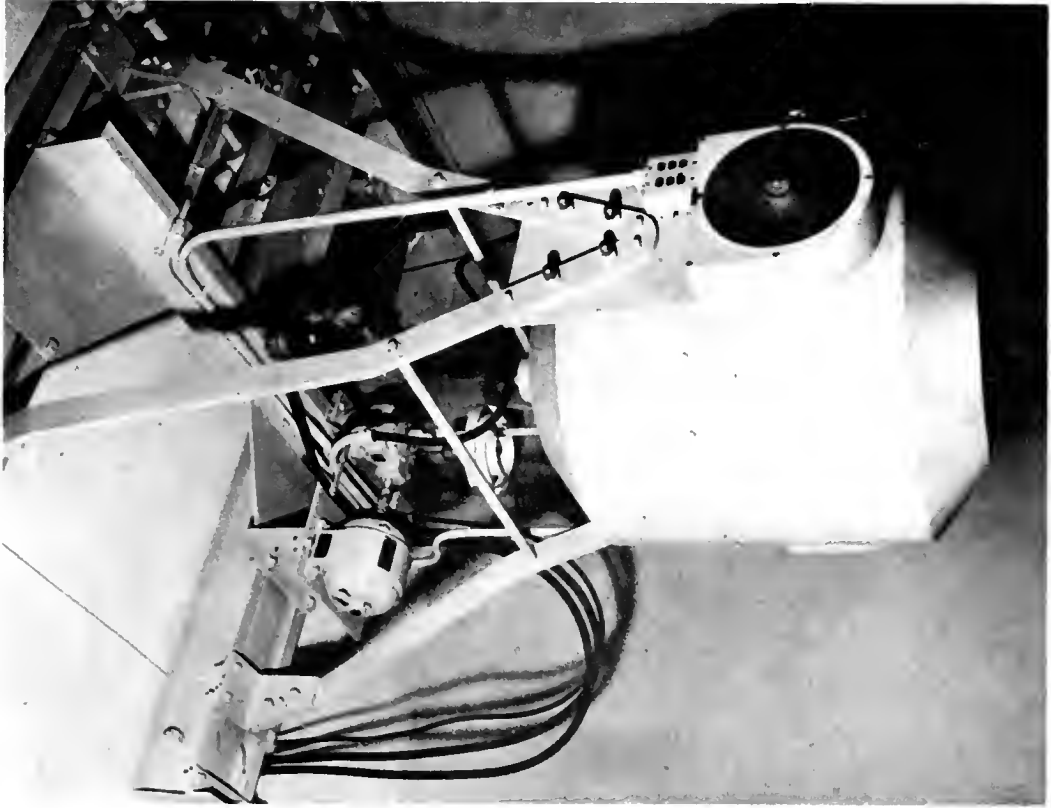

Fig. 3—Radium-beam unit and I-beam track from which it is suspended.

IRRADIATION OF METASTASES

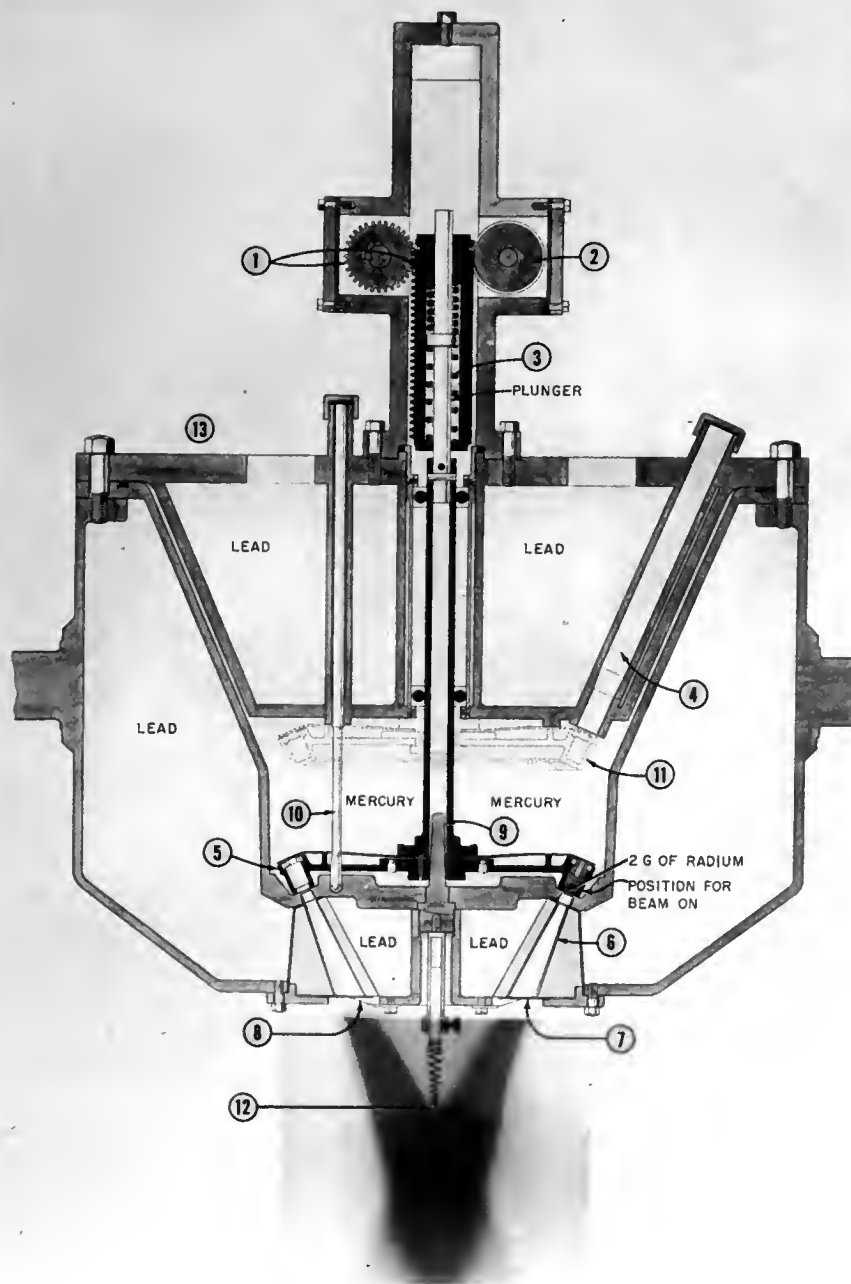

Fig. 4—Diagram of a cross section of the radium-beam head. (1) Rack and pinion for controlling motion of radium-carrying ring up and down; (2) guiding roller; (3) spring compressed to force out mercury at bottom of pool when radium is in treating position; (4) filling hole through which radium was inserted in Belgium; (5) treating position of radium-carrying ring, showing position and angulation of radium capsule; (6) conical collimating channel through lead; (7) brass beta-ray filter covering bottom of beam head; (8) removable graded brass filter to reduce central high point of radiation; (9) cone for centering radium-carrying ring; (10) guide rod to prevent rotation of ring; (11) off or safe position of ring at top of mercury pool; (12) central pointer along which radium-to-skin distance is measured; (13) location of machinery on top of beam head, concealed by cover.

Lead, encased in stainless steel, surrounds the unit, and the assembly of the beam head by bolts in the upper corners of the diagramed beam head can be seen. As actually viewed in the treatment room, the cylinder is extended upward by a cover, which conceals the gearing and motor placed on the top of the beam head (13) so that only the very top of the plunger housing shows.

If we set the distance from the radium source to the skin at 25 cm, then, from there to a point 10 cm below the surface of the skin (meaning 35 cm from the radium source), all the beams come together at their

Figure 5 shows four radiographs made as the radium was brought down lower and lower. First, the individual beams just begin to overlap. Lower, they overlap more. At the skin surface there is a little

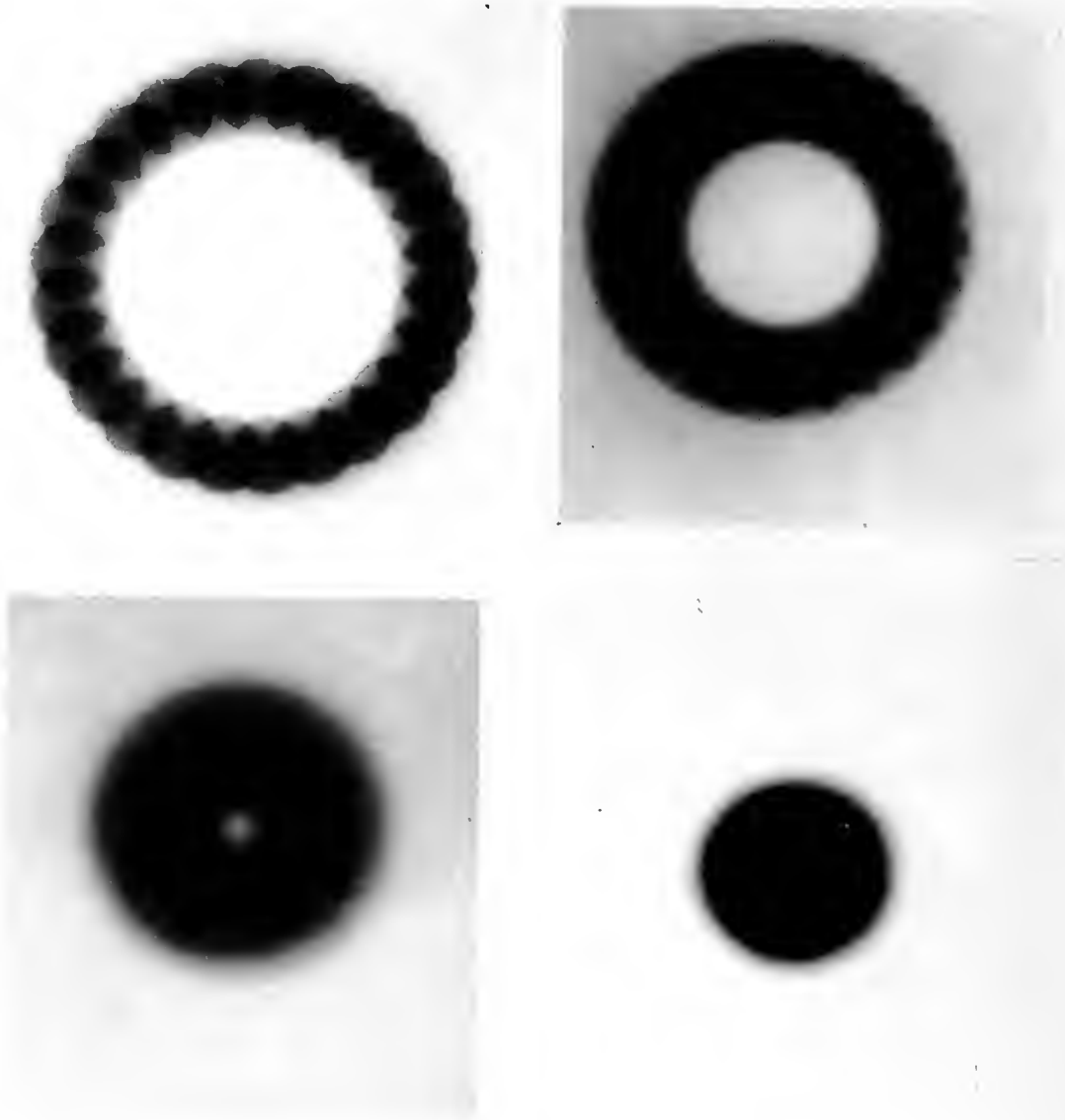

Fig. 5—Radiographs of cross sections of 25 individual beams as they converge. Levels illustrated are 14.6, 19, 25, and 35 cm below the plane of the radium sources. At 25 cm the distribution is that on the skin of the patient when the focus of converging beams is at 10 cm depth. At 35 cm the distribution is that at the focus when 10 cm below surface of skin.

maximum cross-section intensity. The film (at the bottom of the engineering drawing) was exposed in a phantom under the beam. It gives some idea of the way the beams come down, overlap, and cross.

When the distance from the face of the beam head to the skin surface is 10 cm, the first point of all beams crossing the central axis places a hot spot at about 2 cm depth. When the distance is 8 cm, the hot spot is right on the skin.

untouched spot in the center, and, when reactions appear on the skin, this area is always clear. The solid black represents the 10-cm total overlapping when the focus is set for a maximum 10-cm depth.

Figure 6 is an isodose curve with the 10-cm depth set at 100 per cent. There is nearly twice the dosage in a given volume of deep tissue that there is at the skin surface.

Figure 7 shows another isodose curve of similar

IRRADIATION OF METASTASES

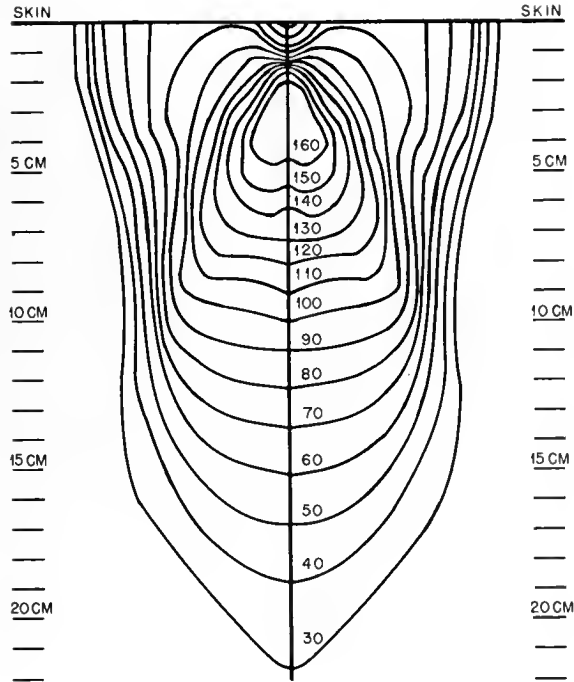

Fig. 6—Isodose curve without filter. Focus is 10 cm below surface of skin. Dose is in percentage of dose to focus; high point is about 150 per cent.

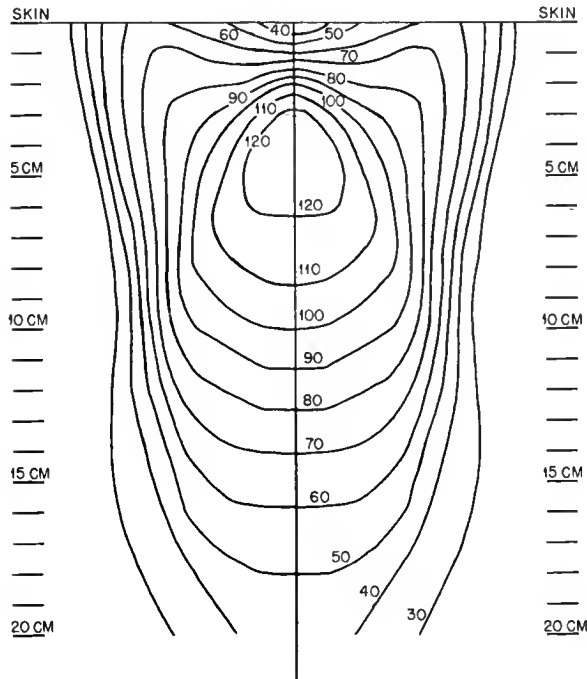

Fig. 7—Isodose curve with filter. Focus is 10 cm below surface of skin. Dose is in percentage of dose to focus; high point is about 120 per cent.

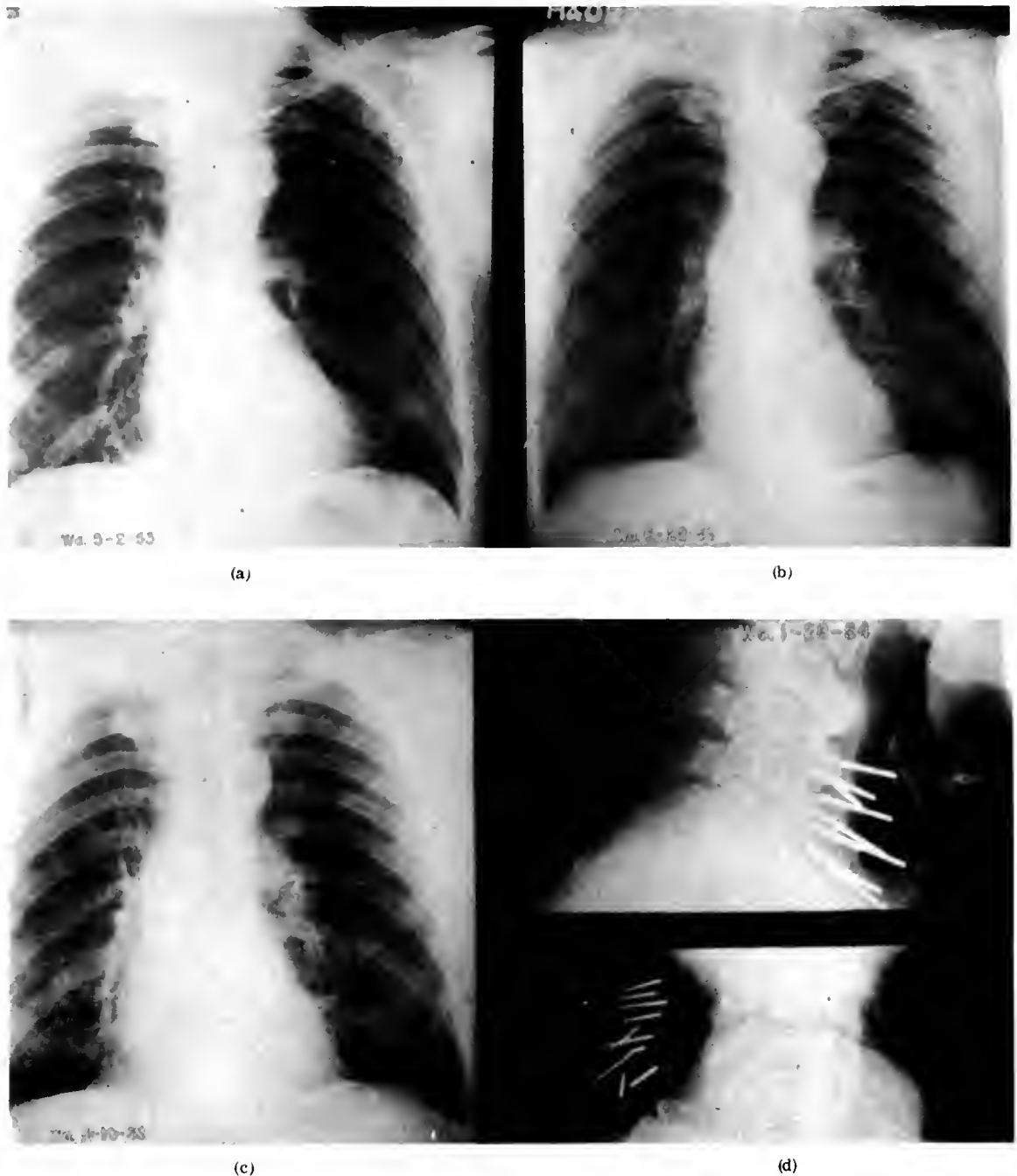

Fig. 8— Patient with advanced Pancoast type carcinoma of right apex of lung and with supraclavicular lymph node, treated by two different technical methods. (a) Mass in the apex, extending into neck, with destruction of the first rib, at beginning of radium-beam treatment. (b) Film taken six weeks later, showing little change. (c) Roentgenogram taken six months later, demonstrating the regeneration of the first rib. (d) Anteroposterior and lateral views of the radium-needle implant in the neck mass.

depth setting but with a peripheral wedge filter. This wedge can be applied from the outside readily; it gives a better pattern of dose distribution for a much more limited, narrower area.

arm. I do not know whether the pain is due to fibrosis or to recurrent tumor. He is in good condition generally, performing his duties as a salesman three years after the first treatment.



(a)



(b)

Fig. 9—Same patient as that in Fig. 8 with Pancoast type carcinoma. Films show more clearly the original bone destruction (a) and repair three years after irradiation (b).

Examples of Patients Treated with Radium-beam Unit

Figures 8 and 9 are offered as examples of worthwhile long-term palliation that has lasted more than three years. The patient had a typical Pancoast type tumor at the extreme right apex. It extended high into the neck so that the upper part was outside the radium-beam field. He was treated daily from May 2 to June 22, 1953, by radium-beam therapy. The manner of treating the neck extension is shown in Fig. 8d. We transfixed the mass with radium-element needles. Subsequently the arm, which had been extremely painful and totally useless (he could not hold a knife or fork nor carry a small case in his hand), improved enough that he could aid in feeding himself, sign his name, and write notes.

Figure 9 shows some detail that Fig. 8 does not show. Practically all the right first rib was destroyed. Three years later, there is a considerable redeposit of bone.

He received 10,000 gamma r in the first two and one-half months to the primary lung tumor; then he was given interstitial radium to the adjacent neck for a dose of approximately 5000 r. He received more irradiation early in 1956, when pain recurred in the

Figure 10 illustrates a good palliative response in a patient recently treated for pulmonary metastasis of adenocarcinoma of the fundus. She had one of the all-too-prevalent and famous hysterectomies of these last few years for carcinoma of the cervix. She is a very active, "full-of-steam old gal" who feels that the television industry cannot go on without her, and she is always hard to catch up with for treatment. Figure 10a is the original chest film made when her only symptom was a minor cough; Fig. 10b is a tomograph showing that the faint shadow in the routine film was probably much more than it seemed to be.

During two and one-half months, she was given approximately 5000 gamma r through each of the areas treated. Figure 10c is a film of the chest taken near the end of the radiation treatment, and Fig. 10d was made three and one-half months later. The patient is free from symptoms and is carrying on her normal activities.

I am not trusting this patient with only 5000 r through each of the treatment areas. I shall add another 1500 r, which may either relieve my conscience or make it more sensitive; I do not know which it will be. I think she will be better off with more radiation. I do not want to leave her with what I regard as inadequate dosage even for palliative purposes.

The next case is a highly malignant spindle-cell sarcoma of the left maxillary antrum, with extensive



(a)



(b)



(c)



(d)

Fig. 10—Metastatic adenocarcinoma of the uterine fundus before treatment (a and b) and partially through treatment (c and d), initiated with high-voltage X radiation and shifted to radium beam. Total dosage at this level approximated 6000 r to upper area and 3400 r to lower area. Since this is not enough for permanent control, radium beam is being continued to 7500 r.

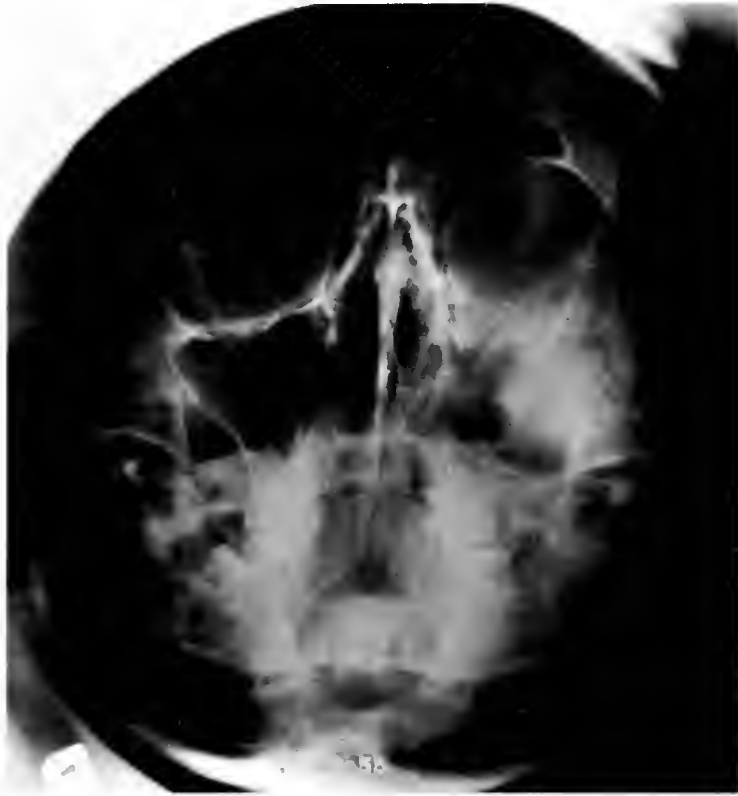

Fig. 11—Sarcoma of antrum with extension to orbit. Treatment: radium-beam irradiation plus intracavitary irradiation as for carcinoma of antrum.

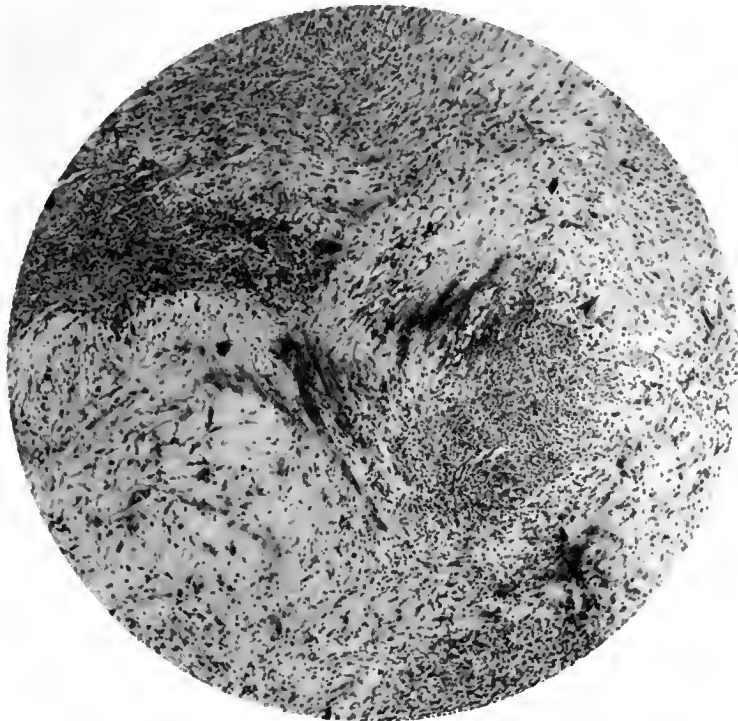

Fig. 12—Histology of case in Fig. 11. Spindle-cell sarcoma.

bone destruction and invasion of the floor of the orbit (Fig. 11). This patient was a girl in her early twenties. She is being discussed to illustrate three points:

1. The external irradiation of the antrum and adjacent primary growth zone was with the radium-beam unit. A tumor dose of 6000 r was given with a barely

small metastatic nodes raised the neck irradiation to above 8000 r tumor dose. Figure 11 shows the extent of disease in the left antrum and the bone destruction and tumor infiltration beyond the antrum. Figure 12 shows the histology of this lesion. Figure 13a illustrates the method used for implanting needles in



Fig. 13—(a) Same patient as that in Figs. 11 and 12, showing radium source (1 mm of platinum filtration) in antrum and radium-element needles (0.5 mm of platinum filtration) in neck (multiple soft involved nodes found on surgical exposure for external carotid artery ligation). Total dose to primary site, radium beam plus linear radium source in antrum, was 8000 r. Total dose to neck, radium beam plus radium-element needles by transfixion, was 8000 r.

(b) A point source of radium much better for technical adaptation and physical accuracy than the linear source actually used in part a. This case is shown as an example of the advantageous value of combining external radium beam with interstitial and intracavitary radium irradiation.

appreciable skin reaction. At slightly under 5000 r to the neck, a negligible skin reaction began to appear.

2. Surgery was performed for drainage and to clear out tumor debris and bone in order to facilitate the placement of radium in the antral area. Surgery also included external carotid ligation, with local dissection and interstitial irradiation of the upper neck on the side of involvement.

3. Intracavitary irradiation in the antral area and interstitial irradiation in the positive nodes in the upper deep cervical neck area were used to enhance the total dosage to these areas. With the interstitial radiation it was not necessary to push external irradiation to skin-damaging levels.

A 1-mm platinum ball carrying 50 mg of radium in the antral area brought the total tumor dose above 8000 r. Platinum needles inserted in the upper neck at the time of vessel ligations and the irradiation of

the neck at the time of vessel ligation. (Figure 13b shows another patient with an ideal radium source implanted. This ideal source is a small platinum sphere containing 50 mg of radium element.)

One and one-half years have elapsed since treatment was started on this girl. She is in good general health and shows no evidence of recurrent disease. She is not disfigured. She has an excellent functional prosthesis. She has gone through a normal pregnancy and now has a normal, healthy male child.

Summary

I can summarize my feelings on supervoltage very simply. External radiation is one phase of a combination of modalities that should be used for the treatment of cancer. Supervoltage external radiation is obviously much superior to lower voltage radiation.

DISCUSSION

CHAPTER 35

Hunt: Dr. Quick has emphasized the clinical approach, the characteristics of the disease, and what is offered by the various modalities, not only radiotherapy but surgery and chemotherapy.

It was rather amazing to see the phenomenal clearances of metastatic carcinoma of the lung. We have seen others during this meeting. May we have a showing of hands by those who have seen metastases in the lungs cleared and the survival of the patient for five years or more? Dr. Smedal, Dr. Cooper, Dr. Tubiana.

Dr. Quick presented also a patient with carcinoma of the cervix, lymphedema of the thigh, and sciatic pain. We may now hope that, with cobalt and megavoltage radiation, better palliation can be attained than is possible with cordotomy.

Dr. Quick has shown the combined use of interstitial radium needles with convergent teletherapy beams in the treatment of squamous-cell carcinoma metastatic to the ilio-inguinal nodes. Does he feel that teletherapy may replace interstitial radium needles in metastatic carcinoma in lymph nodes and also in the tongue, in the light of his own developing experience? Does he feel that teletherapy and megavoltage methods may replace radium sources in the uterus and vaginal fornices in the treatment of carcinoma of the cervix with associated metastases to pelvic nodes?

Ellis: I should like to ask if you can vary the size of the volume treated with the machine.

Dr. Quick: No, as it is arranged, we cannot. I want to say just a little more about the use of other sources of radiation to show that we are not too totally dependent on supervoltage for everything.

A very active lawyer had had a small, rather insignificant-appearing squamous-cell carcinoma of the glans penis removed surgically four years before I saw him in the fall of 1951. The wound had not healed well, and this was revised by the urologist in our institution.

The man lived a considerable distance from New York, and he returned two or three times to see his urologist. We then did not see him until he came in with a large mass in the left lower inguinal area, which I interpreted as a metastatic node arising not in the inguinal group proper but in the Scarpa's triangle nodes. It was red over the surface and a little soft to palpation. The patient was running a little fever and having a good deal of local discomfort. I could feel also what I thought were two nodes just medial to the vessels.

We put him on large doses of antibiotics and gave him very, very small doses of heavily filtered X radiation, gradually increasing the dose until he had received about 2000 r. By this time, probably because of the antibiotics, the lesion had quieted down, but a little redness in the skin was still noticeable. We let him have a couple of weeks without radiation but continued the antibiotics.

We then admitted him to the hospital, where I performed a full, complete, wide dissection of the area and implanted radon seeds along the upper border and along the side of the superficial fat path. The wound reacted as so many inguinal sections do: there was a pouring out of lymph in tremendous amount, flooding the wound. We did not obtain primary healing; there was a small open area that did not quite heal.

About a week later we did the right side. All the local inflammation, as far as we could determine, had subsided. We were able to outline the vessels very accurately by palpation and by marking them out carefully. I then implanted radium-element needles in a deeper part (2-mg needles, 0.5 mm of platinum filter with the radium distributed on the basis of 0.66 mg/cm³ of active length).

These needles were inserted tangentially as close to the vessels as we could put them with reasonable safety. I assume that we were not more than 0.5 cm from the vessels on the inside, and yet I think we were not too far away from any point. Altogether, the patient had 60 mg of radium in the inguinal area, 20

needles of 2 mg each and 20 needles of 1 mg each; in this area there was complete regression.

This took place in late fall, 1951; I have seen the patient at fixed intervals since. He is still in good health, an active lawyer able to carry on his business and play a reasonable amount of golf. Rather than depend entirely on supervoltage radiation, we have something more to offer.

Dr. Ellis has asked about whether we can vary the size of the field; no, we cannot. With little effort we could remove the nosepiece from the machine and replace it with another. It would be a somewhat heavy job, not one to be repeated too often—not even every day, I should say. However, the principle of it, I think, does commend the idea.

If it were possible, I should be inclined to have four or five separate patterns, with whatever amount of cobalt or cesium the money would produce, divided and put in four or five different units rather than all in one; I think that one can easily visualize patterns

that still maintain the principle of fixed multiple-beam irradiation.

Hunt: Is telecobalt going to replace radium entirely, or is there still a place for radium sources in the treatment of advanced lesions? I am sure you have answered this, but you might explain it.

D. Quick: For cases like the patient just mentioned, I showed that whether it is radium, or cobalt, or another of the isotopes does not much matter; it is a matter of the principle of the thing.

I must say that I have a very kindly feeling toward our particular radium unit because it is an absolute fixed source. We cannot treat many patients per day; the unit will not keep a large, busy clinic going and handle a great volume of tissue; but it remains a fixed source, not variable, and in this it has something to commend it as a yardstick and guide, I think, in a great many ways.

Assessment of the Results of Therapy

CHAPTER 36

Vincent P. Collins

Baylor University College of Medicine
Houston, Texas

The Teletherapy Evaluation Program was conceived as an investigation with a practical goal. Support of, and participation in, the program were for the purpose of development of an improved modality of radiotherapy. A part of the program would eventually be an appraisal of what had been accomplished, and in the end the effectiveness in the treatment of cancer would be a measure of its worth.

The problem of clinical evaluation would be to establish and measure the effects of treatment. There was enough evidence and experience already available to indicate that the advantages of high-energy radiation were real, but these advantages were relative rather than absolute. It was already apparent that the division of opinion would lie between the view that these advantages were self-evident and adequate and the view that they were unimportant or ineffective as far as increase in the curability of cancer is concerned. The factors that would enter into appraising the results of treatment would be (1) the type of cancer problem submitted for treatment, (2) the techniques of radiotherapy used in treatment, and (3) the methods used for measuring the effects of treatment.

This is a problem common to all medical therapeutics. Immense resources have been brought to bear upon the evaluation of many forms of therapy for many kinds of cancer. The contrary products of these studies gave cause for concern that evaluation by standard methods would be inconclusive and that the contribution of the Program to cancer therapy would remain a subject of divided opinion.

Cure rates and survival rates have long been the yardsticks for measuring the effectiveness of cancer therapy. Education in the statistical methods has led to a gradual improvement in the recording of treatment results, but there is still general skepticism toward any sudden change in the prognosis of cancer. There is a remarkable uniformity in the recording of cancer results. There is uniformity in the effect of treatment in different institutions and by different

treatment policies. There is uniformity in that everyone's results consistently improve. This is the more remarkable in that mortality from cancer is not appreciably altered.

Statistical analysis supplies numerical values for the purposes of comparison. These are reinforced by an estimate of the likelihood that a given value will be duplicated under similar conditions. Great precision is possible in a computation of the likelihood that a given value will be obtained again. The problem of encountering and identifying similar conditions is less susceptible to control. There is an enigmatic quality to the disease, the patient, the human being responsible for treatment, and the human being behind the computer. None of these, individuals or diseases, lend themselves to measurement. This tends to qualify the advantages of the most advanced statistical techniques. Such computations derive their meanings from a thorough understanding of the source of material. They may be dignified or mocked by the manner in which they are used. Statistics are like lamp posts. They are utilitarian, decorative, expensive, or hazardous, depending on one's point of view. They can be used for illumination or support.

The implications of cure rate and survival rate need to be scrutinized closely since these are most often used as an index for establishing or comparing the effectiveness of treatment.

In reporting improvement in treatment methods in a series of Wilms's tumors, Gross¹ ultimately reported a cure rate of 47.3 per cent. He states, "A review of the Children's Hospital material indicates that about half the patients can be permanently cured. . . ." That the criterion of cure or the period of follow-up was vague is not important; the implication is that, in half the patients, the tumor was confined to the kidney and to the renal fossa and therefore it could be removed or eradicated by local treatment. If it is the nature of Wilms's tumor to remain localized until the time of diagnosis and

treatment, then this is most encouraging information. It would mean that half the patients in any series were actually curable by local methods of treatment when first seen. Our experience with this disease, however, leads us to doubt the validity of such a proposition. It is necessary to consider whether some special selection went into the series to render it more favorable than any other. It is possible that this is merely a chance occurrence in which all favorable cases tend to be localized in one small series. The likelihood of this happening could be calculated.

Continued improvement in results of treatment in this series is reported. From 1914 to 1930, the percentage of cures was 14.9; from 1931 to 1939, cures increased to 32.2 per cent; and from 1940 to 1947, they rose to 47.3 per cent. In accepting improvement from 15 to 50 per cent, the statement is that this is due to improved local measures, surgery, and particularly radiotherapy. The implication is that patients in other series were not cured or are not cured because of failure to control localized disease. This also implies that disease remains localized until time of treatment and then enters a fatal phase of dissemination which is preventable by proper surgical technique and postoperative irradiation. That there are such mechanisms of failure susceptible to our methods of treatment is the premise of our continued endeavor, but we must assess their plausibility. Certainly, before accepting a cure rate of 47.3 per cent as possible achievement in any series of Wilms's tumor, it would be necessary to accept a view that Wilms's tumor is a localized disease in approximately half the patients.

Let us consider the implication of a cure rate. Of the patients who present themselves for treatment apparently eligible for cure, some will have localized disease, and some will have occult metastases. Those who contribute to the cure rate or clinical cures will be those who did in fact have local disease. The disease being completely removed by local treatment, these patients continue to attend their follow-up as clinical cures.

For a while, also, patients with occult metastases will continue to attend their follow-up, as apparent clinical cures, until such time elapses as the tumor requires to grow to clinical size. The patients who are excluded are those whose tumors reach a size of recognition somewhat earlier and those who die.

Consider how you could improve a cure rate. Treatment cannot influence the number of patients who have localized disease in the material as it presents for treatment. Treatment cannot alter the rate of growth, which governs the time interval during which a patient will remain apparently clinically cured before his metastases become evident. If, then, we claim an impressive rise in cure rate, we must be able to account for the fact that there are these limitations that put a ceiling upon the possible cures that will be achieved.

Survival rates also merit critical examination, and for this we may use the two series of carcinomas of

the breast reported by Haagensen and Stout.²

IMPROVEMENT IN RESULTS OF TREATMENT OF BREAST CANCER

	1915-1934	1935-1942
Absolute 5-year clinical cure	22.2%	38.6%
Absolute 5-year survival rate	25.3%	47.2%

Here improvement of almost one hundred per cent in survival rate was explained by the authors as being due to the tendency to rely more upon surgery and less upon radiation, to a more radical and a more meticulous operative technique, and to a more critical selection of cases for radical mastectomy. For such an impressive improvement in the outlook for the patient with breast cancer, it should be possible to describe in somewhat less vague detail the technical improvement that had allowed patients to be cured who formerly were not being cured.

Examining the meaning of "survival rate," we recognize that patients who present themselves include those with localized disease only, who are cured when the local disease has been removed, and so contribute to the long survival group who attend follow-up clinic. However, this group will also include patients with occult metastases and patients living with evident disease. It excludes patients who have died with or without known disease.

The rate of growth of cancer influences the survival rate. Those with disease that grows rapidly will be the patients who die first and who are excluded from the survivor group. Disease that grows somewhat more slowly will permit patients to attend their follow-ups with persistent disease, uncured, but still survivors. Those with disease that grows still more slowly will continue to be regarded clinically cured survivors until occult disease finally becomes manifest.

Considering that the effect of treatment by surgical or other therapeutic methods must be local in nature because of anatomic limits to what can be removed and biologic limits to the volume that can be adequately irradiated, the direct and local effect of treatment tends to be obscured by cure rates and survival rates.

Cures or survivals may well be influenced by treatment, but they are subject to the following additional powerful influences.

1. Time of diagnosis: diagnose a tumor a year earlier and add a year to survival time, even without treating.

2. Extent of disease at time of treatment: all local treatments are equally ineffective in terms of cure if metastases are already present in lung, bone, and liver.

3. Rate of growth of tumor: even if technically adequate treatment eradicates local disease, the superiority of the method is obscured by the short survival of a patient with a rapidly growing tumor,

whereas undeserved credit may go to an inadequate technique that permits local recurrence long deferred by slow growth.

When the effect of treatment is estimated only in terms of cure rate or survival rate, it is not surprising that a certain similarity prevails for a wide variety of treatment policies and treatment methods because of the buffering effect of the factors mentioned.

A system for the evaluation and comparison of the specific effects of treatment is proposed, which is based primarily upon the local effect of treatment and is intended to be independent of cure, survival, or even of the time element.

This evaluation is based upon (1) local success or failure, (2) whether a complication of treatment occurred, and (3) the development of distant metastases. Table 1 gives eight possible categories of treatment results.

Table 1—EIGHT CATEGORIES OF TREATMENT RESULTS

Category	Local persistence	Complication of treatment	Distant metastases	Remarks
1	0	0	0	Satisfactory treatment. No modification indicated.
2	0	0	+	Satisfactory treatment. No modification indicated. Distant metastases are no contraindication.
3	0	+	0	Technique and dose adequate for control. Modify to prevent complication if possible, but control of disease cannot be jeopardized to prevent complication.
4	0	+	+	Technique and dose adequate. Modify to prevent complication. Complication is not justified to obtain control if metastases are known or likely.
5	+	0	0	Improper technique or inadequate dose. Modify technique or increase dose to limits of tolerance.
6	+	0	+	Improper technique or inadequate dose. Modify technique or increase dose but not at increased risk of complication.
7	+	+	0	Local persistence may be inevitable for a radio-resistant lesion, but treatment is improper if it only adds complication. Reduce dose to limit of tolerance.
8	+	+	+	Treatment that permits local persistence and produces complication in likelihood of presence of distant metastases should be avoided. Improvement required in technique and judgment.

The following case histories are intended to illustrate the use of this method of evaluation. They emphasize that observable findings in individual cases, even with short-term follow-up, can provide a "best available answer" to indicate whether a treatment method should be continued, modified, or abandoned.

Case 1. The patient was a 67-year-old white woman with carcinoma of the right breast.

After a simple mastectomy, postoperative radiotherapy was given to the chest wall, axilla, and supraclavicular region. By means of 2000 kv, 4000 r was delivered in three weeks.

The results were no evident disease in the treated area, no complication of treatment, and no evidence of distant metastases.

An appraisal 12 months after diagnosis showed: local persistence, 0; complication, 0; and distant metastasis, 0.

Comment: Simple mastectomy followed by radiotherapy proved satisfactory treatment for this patient. There was minimal morbidity, no functional impairment, and no adverse effect on the patient or on the course of the disease. The method is suitable for further application in this older age group without modification.

Case 2. The patient was a 57-year-old white man with carcinoma of the esophagus.

After the patient had experienced a three-month history of dysphagia, X-ray studies showed a small lesion in the lower third of the esophagus. At surgery, extensive mediastinal involvement was encountered. Radiotherapy was given with the intent of maintaining a patent esophagus. A tumor dose of 5000 r was

delivered through four oblique fields in 26 days by means of 2000 kv.

From the X ray, the primary lesion disappeared. The patient swallowed well until the time of death nine months later with extensive liver metastases.

An appraisal nine months after diagnosis showed: local recurrence, 0; complication, 0; and distant metastases, +.

Comment: This is a satisfactory technique and dose, suitable for use even in the presence of distant metastases. No modification is indicated.

Case 3. The patient was a 68-year-old white man with carcinoma of vallecula and epiglottis, with bilateral cervical lymph-node metastases.

He was treated solely with X-ray therapy by means of a cross-firing technique to include the primary and the metastases, sparing the larynx and spinal cord (tumor dose 5000 r in four weeks with 2000 kv).

There remained no clinical evidence of disease in the pharynx or in the cervical region. Two spicules of bone have been discharged from the inner aspect of the angle of mandible on each side; no changes are evident by X ray, but this is interpreted as small areas of osteonecrosis included in a hot spot of the treatment technique.

An appraisal six months after diagnosis showed: local persistence, 0; complication, +; and distant metastases, 0.

Comment: This is a useful and simple technique, but it should be modified to protect the angles of the mandible. It should be recognized that this was a radiosensitive tumor, and the technique and dose should be used again in similar circumstances.

Case 4. The patient was a 56-year-old white man with carcinoma of the tongue.

He was a chronic alcoholic who had neglected a known lesion for nearly one year, and treatment, when begun, was intermittent over a period of 23 days. A total of 6600 r was delivered by a combination of external X rays and interstitial radium.

There was prompt regression of the lesion, but healing was very slow. Six months after treatment an area of necrosis developed at the treatment site, and a mass appeared in the left side of the neck. An en bloc hemiglossectomy and neck dissection was carried out. No cancer was found in the tongue. There was metastasis to a single lymph node.

An appraisal (of radiotherapy) six months after diagnosis showed: local persistence, 0; complication, +; and distant metastases, +.

Comment: The dose of radiation was too high. Contributing factors to this error were (1) departure from standardized time pattern for treatment and (2) lower tolerance of normal tissue to radiation in alcoholics. The time pattern of the technique should be maintained to permit a more accurate estimate of tolerance dose. The dose for older persons or chronic alcoholics should be reduced by 10 per cent below that for average patients.

Case 5. The patient was a 73-year-old white woman with carcinoma of the cervix.

In 1951, while the patient was under study for severe hypertension, a biopsy was diagnosed as carcinoma of the cervix, but she refused treatment. In June 1955, a repeat biopsy showed chronic cervicitis. In November 1956, the patient returned with a history of vaginal bleeding for one month. The cervix was fixed, and induration extended to the left lateral wall. Because of her extremely poor general condition, only radium therapy was used. A dose of 3000 r was delivered to point A in two radium applications two weeks apart.

There were no complications of treatment and no evidence of distant disease, but the patient died in March 1957 of hypertensive cardiovascular disease. Autopsy showed histologic persistence of carcinoma of the cervix.

An appraisal three months after treatment and five years after diagnosis showed: local persistence, +; complication, 0; and distant metastases, 0.

Comment: The dose was inadequate to eradicate the local disease, although clinical control was achieved. For an elderly patient with cancer of this long natural duration, the dose should be increased cautiously. The result obtained (+00) is preferable to local eradication with complication (0+0).

Case 6. The patient, a 40-year-old white woman, underwent a radical mastectomy in 1952 for carcinoma of the breast with axillary metastases.

She remained symptom free for three years, after which a mass of nodes appeared in the right axilla. This was removed surgically. One month later, nodes appeared in both supraclavicular regions and in the opposite axilla. Prompt regression occurred after radiotherapy (tumor dose of 4000 r in 27 days with 2000 kv), but widespread metastases developed and advanced rapidly.

An appraisal four years after diagnosis showed: local persistence, +; complication, 0; and distant metastases, +.

Comment: Radical mastectomy alone was inadequate to control the disease in the site operated upon. Because of the high incidence of local recurrence if axillary metastases are present, postoperative radiation should be given routinely.

Case 7. The patient was a 49-year-old white woman with squamous carcinoma of gingival sulcus.

The primary lesion was locally excised, and the defect was reconstructed with a bar bolt. Within one month there was local recurrence, and a radical resection of the mandible with neck dissection was performed. A wound infection caused loss of substance of the cheek, and the patient was unable to eat.

Two months after radical surgery, recurrence developed in submental and both cervical regions. Radiotherapy was given to cause regression of the nodes and to clean up the local lesion (tumor dose 3000 r in 25 days with 2000 kv). Treatment produced temporary regression of the lesion, but there was persistent disease with fistula and infection. Six months after diagnosis there was no clinical evidence of distant metastases, but there was marked debility.

An appraisal six months after diagnosis showed: local persistence, +; complication, +; and distant metastases, 0.

Comment: The chance for cure was probably lost with the first surgical procedure, which was inadequate to eradicate the local disease. The primary treatment should have been either a more radical operation or radiotherapy. A dose of radiotherapy

adequate to eradicate the lesion could not be delivered later because of diminished tolerance of tissues following two operations and in the presence of infection.

Case 8. The patient was a 60-year-old white woman with carcinoma of the cervix.

A hysterectomy for fibroid uterus was performed, and carcinoma of the cervix was found in the surgical specimen. Two years later, pain in the region of the left hip led to the discovery of a mass in the left parametrium and X-ray evidence of destruction in the adjacent portion of the ilium. With 2000-kv radiation a tumor dose of 6000 r was delivered in five weeks.

The left parametrial mass regressed, and there was some reossification of bone. Three months later a fracture of the left hip occurred, apparently due to excessive radiation. The left ureter became obstructed, and the patient died seven months after radiotherapy. Autopsy revealed that there was persistent disease in the pelvis with extensive metastases to para-aortic nodes.

An appraisal seven months after radiotherapy showed: local persistence, +; complication, +; and distant metastases, +.

Comment: The parametrial recurrence with bone involvement must be considered as a local persistence of primary disease, the fracture of the hip is a complication of treatment, and autopsy showed extensive metastases. The primary treatment was inadequate; the treatment of recurrence was excessive. No aspect of this case merits approval.

The material referred for radiotherapy varies with the aggressiveness of the surgical policy that holds from one institution to another. Under any circumstance material referred for treatment is likely to include many patients with advanced cancer because there is no category in radiotherapy that is quite comparable with surgical inoperability. Patients with inoperable, incurable, or advanced disease are often referred for palliation, and it sometimes happens that efforts on their behalf are slighted because of the prevailing view that cure is the only worthwhile goal of treatment. The stated policy of many cancer institutes is to exclude advanced cancer, admitting only those who have early, operable lesions or those who are likely to contribute to the improvement of cure or survival rates.

In addition to the actual benefit to the patient of treatment that is termed palliative, such patients represent a very satisfactory group for the direct and early comparison and demonstration of the advantages of such a modality as Co⁶⁰ teletherapy. The suggested system of recording results outlined here takes into account the benefit to patients with advanced cancer and permits the evaluation of the effectiveness of treatment regardless of the stage of disease.

References

1. R. E. Gross, *The Surgery of Infancy and Childhood*, pp. 558-605, W. B. Saunders Co., Philadelphia, Pa., 1953.
2. C. D. Haagensen and A. P. Stout, *Carcinoma of the Breast*. III. Results of Treatment, 1935-1942, *Ann. Surg.*, 134: 151-172 (1951).

DISCUSSION

CHAPTER 37

Cooper: The ideas presented by Dr. Collins deserve more than hasty consideration, and I hope he will present them somewhere else when they can be considered in a more leisurely fashion.

He expressed concern that evaluation by standard methods would be inconclusive (i.e., evaluation of new sources and techniques) and that the contribution of the Teletherapy Evaluation Program to cancer therapy would remain a subject of divided opinion.

This conference has well demonstrated that this concern is justified. There is certainly reason to fear that the place of Co^{60} teletherapy in the treatment of cancer will remain a subject of divided opinion.

Ellis: I think another category should be added, and that is not the evaluation of the treatment and behavior of the lesion but of the treatment and behavior of the whole patient. We do want to know whether or not the management of the patient has been successful.

For instance, a local lesion might be treated satisfactorily, and at the same time metastases needing surgical treatment might be neglected.

Collins: In reply to Dr. Ellis, I think that evaluation of the treatment and behavior of the patient is certainly necessary. Should the method of evaluation come to the level of practical clinical application, the complications would have to be listed and weighted. These will vary since, for example, the follow-up of a brain tumor is different from that of a carcinoma of the cervix. One category of complication might well be the patient's reaction to the treatment. Complications would obviously have to be weighted, from such minor things as depilation, which I myself am not inclined to take seriously, to systemic reactions or severe incapacitating radiation pneumonitis. All these are complications but could be given weight relative to the specific modality or the specific lesion being considered.

Section

H

Indications and Contraindications

Milton Friedman
(presiding)

Short Source-to-Skin Distance Co⁶⁰ Teletherapy

CHAPTER 38

Norman Simon

Mount Sinai Hospital
New York, New York

Many curable tumors are accessible and superficial. For their treatment a short source-to-skin distance (SSD) with Co⁶⁰ teletherapy provides a desirable dose fall-off, small penumbra, and high output. The skin-sparing effect allows cancerocidal doses to be given through single portals to superficial cancers of the cervical and inguinal lymph nodes, the parotid and thyroid glands, the larynx, and the middle ear. As an advantage of Co⁶⁰ over conventional 200-kv X rays, skin sparing is far more important than increase in depth dose. Co⁶⁰ teletherapy has made 200-kv X-ray apparatus practically obsolete.

The hectocurie unit is a unique concept, and I shall discuss our limited clinical experience with it. This being the fourth day of the meeting, it is like "flogging a dead cat" to give more information on cobalt. You have heard isolated and integrated information, and I am certain that the information is "in" on most facts I shall mention.

I can relate the experience of my associates, Dr. Sidney M. Silverstone and Dr. Stuart I. Gurman, and present some of our views, which should prove to be provocative. With a hectocurie Co⁶⁰ teletherapy unit we have treated, in two years, 375 patients having cancer.

Whenever the virtues and the advantages of Co⁶⁰ hectocurie teletherapy over conventional, or obsolete, 200-kv X rays are discussed, it is customary to mention the following factors: (1) the increased depth dose, (2) the decreased bone absorption, (3) the increased tolerance of the skin, or the skin-sparing effect, (4) simplified techniques for treatment, (5) decreased radiation sickness, and (6) dependability.

Paradoxically, as an advantage over 200-kv X rays, the increased depth dose of Co⁶⁰ hectocurie teletherapy receives undue prominence. In the treatment of deeply situated cancers, there are few if any regions in the human body which cannot be reached with a cancerocidal dose by means of conventional 200-kv X rays. The penetrating Co⁶⁰ gamma rays may deliver their dose by simpler treatment plans; whereas the 200-kv

X-ray beam may necessitate multiple portals or rotation.

As an example, cancer of the esophagus is not incurable because we are unable to administer a large enough dose of radiation with 200-kv X rays. The futile end results are little better at higher than at lower energies thus far, but the disease is palliated with perhaps more frequency and less morbidity with super-voltage.

Similarly, the limitation in our ability to cure pelvic tumors is not attributable to lack of depth dose because even 200-kv radiation can administer sufficient dosage to the pelvis to damage irreparably the intestine adjacent to the cancer before tumors can be controlled.

In the search for greater and greater depth dose to the deep cancer, we tend to overlook the plight of the superficial or accessible cancer. Our fellow conferee, the eminent Professor D. W. Smithers of England, has written a valuable book, "The X-ray Treatment of Accessible Cancer."

He opens by saying, "The great majority of patients with cancer who are cured by radiotherapy are those whose tumors arise in the skin, external genitals, buccal cavity, breast, and cervix uteri." In the same vein, Ralston Paterson called accessible cancers curable; whereas other malignant tumors were termed treatable and incurable.

In our series of 375 patients treated with the hectocurie teletherapy cobalt unit, the great majority of curable cancers are superficial or accessible. These tumors are most efficiently treated with a short SSD. It is for these relatively superficial lesions that the Oak Ridge Institute of Nuclear Studies originally designed the hectocurie unit we have used. It is an added bonus that made this machine useful for deep lesions and general radiotherapy.

The advantages of short SSD Co⁶⁰ teletherapy for superficial cancers are (1) high output, (2) more rapid fall-off of dose with depth, (3) smaller penumbra, (4) skin sparing, and (5) decreased bone absorption. The high output allows the use of smaller sources with

easier protection requirements. Skin sparing and decreased bone absorption are not inherent characteristics of short distance, but they are important in the evaluation of short-distance therapy.

Table 1 indicates the output of our 306-curie teletherapy machine after two years' decay. From these

Table 1—OUTPUT OF 306-CURIE Co^{60} HECTOCURIE TELETHERAPY UNIT

Roentgens/min	SSD, cm
67	30
50	35
25	50
12	70

data it can be seen that an exposure of 300 r in air at the surface is administered in about 4 min at 30 cm SSD and in almost 30 min at 70 cm SSD. The impracticality of the longer treatment time seems evident.

The central-axis depth doses at 30 cm SSD for cobalt are about the same as those of 200-kv X rays at 50 cm. More penetrating beams at greater SSD are not necessarily required in the treatment of accessible cancers. All doses cited hereafter are exposure doses.

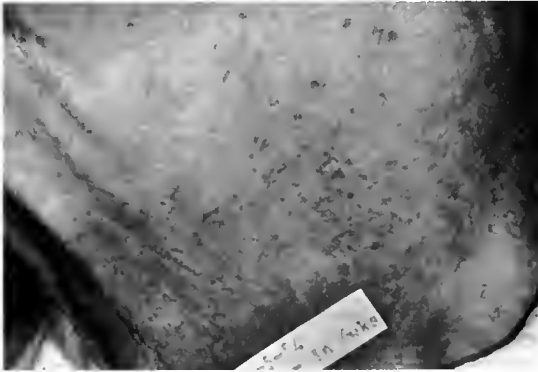

Fig. 1—Skin of the neck of a 94-year-old man on the day of completion of cobalt teletherapy. An exposure dose of 4500 r in air was given to each lateral opposing laryngeal field in six weeks. The reaction of the skin to cobalt radiation is much less severe than that with 200 kv similarly administered (see Fig. 2).

The geometric penumbra with our Co^{60} teletherapy unit increases with distance and is minimal at the shortest SSD of 30 cm. A small penumbra is important in the treatment of relatively superficial and curable cancers because these tumors are treated to a high dose and may well have sensitive normal tissues adjacent to the tumor.

Short SSD's are applicable particularly to the treatment of tumors of the head and neck. Of the 375 patients treated in the past two years, 75 had tumors of the head and neck. Of these the largest category was the larynx, a curable category. The next largest was the thyroid, which I have classified as a treatable but not necessarily curable group. The next largest is the brain, an incurable group. The significant feature

is that, in our concept, over half the head and neck tumors are in a potentially curable group.

In this category of head and neck tumors, all are treated best with short SSD. I should like to illustrate simple treatment plans and minimal skin reactions in the following cases.

Figure 1 shows the skin of the neck of a patient who has just completed therapy with Co^{60} for carcinoma of the larynx. The exposure dose to each of two lateral portals was 4500 r in air. Our treatment with cobalt is essentially the same as the method of the late Dr. William Harris with 200 kv. The experience of treating many patients with carcinoma of the larynx with 4000 r in air to each opposing portal with 200 kv provided a basis for comparison with cobalt. Skin reactions with 200 kv are characterized by wet desquamation, as illustrated in Fig. 2. Reactions in the larynx are somewhat less with cobalt than with 200 kv. Epithelitis with membrane formation in the larynx is less frequent with cobalt.

Of the curable lesions treated with radiation, carcinoma of the larynx is most ideally suited for treatment with a cobalt hectocurie unit at short SSD. The patients tolerate the treatment well, and results should be at least as good as those obtained with 200-kv X rays and telradium units such as are used by Dr. M. Lederman in Professor Smithers's institution.

Carcinoma of the thyroid and metastatic lymph nodes of the neck (15 of our patients) are also satisfactorily treated, although not necessarily curable, by short-distance cobalt therapy.

Figure 3 shows the skin of a 27-year-old woman who had carcinoma of the thyroid, which was treated postoperatively. The picture was taken on the day of therapy completion. She had received an exposure dose at the surface of the skin of 6000 r in air in four weeks through a single field.

It might be important to present a technical feature pertaining to irradiation of the neck with cobalt at this time since the question has intruded itself into this meeting. The problem of sparing the spinal cord from overirradiation with a Co^{60} hectocurie unit may not exist with other types of radiation therapy. As seen in Fig. 4, two adjacent fields given an exposure dose of 6000 r each will result in a dose of more than 6000 rads in the spinal cord, a dose the cord may not be able to tolerate. When two fields are placed in the contour of the neck to treat the thyroid to 6000 rads, the spinal cord may receive as much as 7000 rads. With 200-kv radiation this danger to the spinal cord has not been present because the severe skin reaction limited the exposure and depth doses. It is only because the skin is spared with Co^{60} and exposure doses of 6000 r in air can be given that excessive radiation may reach the spinal cord unless the therapist is wary. Figure 4 also illustrates the fall-off of radiation to safe levels when thyroid cancer is treated by a single anterior field with short SSD (30 cm). Cancer of the thyroid is a lesion that would be difficult and, I might even add for provocation, impossible to treat to such a high dose with 200-kv X rays. A longer SSD with Co^{60} teletherapy would only have achieved use-

lessly greater depth doses in the pharynx and spinal cord.

Similarly, the parotid gland can be irradiated to 6000 rads with a single portal at a short SSD. As an

treatment cone in direct contact with the skin. Figure 6 shows the reaction at its height; wet desquamation of the skin did not occur. Although this treatment was administered with a short SSD, the hair on the opposite



Fig. 2—Complete desquamation of skin in 200-kv irradiated carcinoma of the larynx two days after radiation (4100 r exposure dose). This desquamation is never seen in cobalt-irradiated patients even with exposure doses of 6000 r in air.



Fig. 3—Neck of patient whose thyroid received an exposure dose of 6000 r in air in four weeks with a single direct portal. The reaction is merely a dry erythema with some pigmentation.

example, Fig. 5 shows the skin overlying the parotid gland in a patient who had had a recent incomplete excision of adenocarcinoma of the parotid gland. About one month later the patient had received an exposure dose of 6000 r in air through a single portal with the

side of the head fell out before the hair on the treated side.

The parotid gland cannot be irradiated to doses of 6000 rads with 200-kv X rays; because of the difficulty of reaching a high dose, institutions limited to the

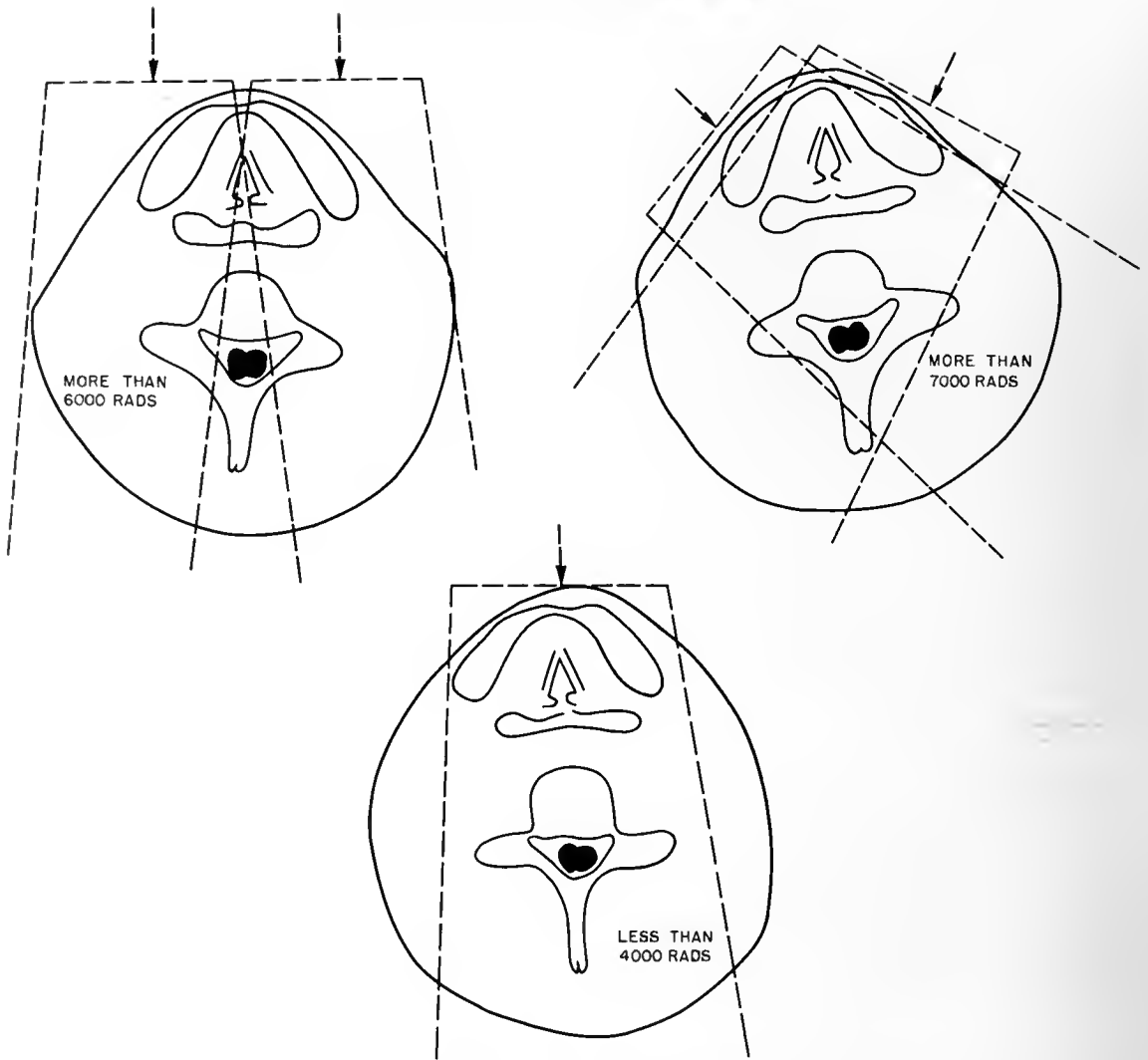

Fig. 4—Dose to the spinal cord when each field receives an air dose of 6000 r. The spinal cord receives dangerously high doses when cobalt portals overlap in the treatment of thyroid cancer. When a single anterior field at short SSD is used, the radiation falls off to safe levels in the spinal cord.

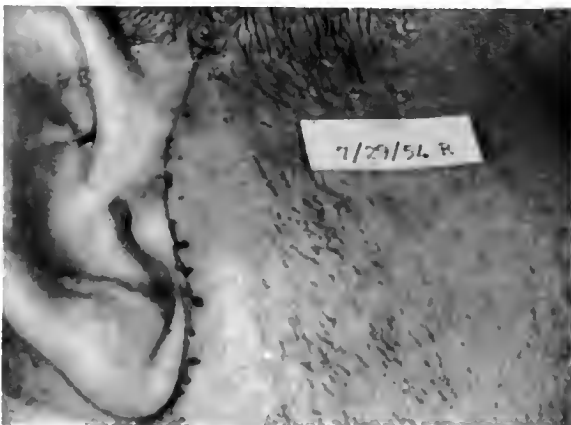

Fig. 5—Adenocarcinoma of the parotid gland after recent incomplete surgical excision. Picture was taken just before cobalt teletherapy.

200-kv range frequently elect to implant parotid tumors with radium. Even though none of us can predictably cure carcinoma of the parotid with radiation, cobalt teletherapy at short distance represents a tolerable method for the patient and one of the most effective methods for the radiotherapist.

I shall demonstrate a dramatic use of short SSD cobalt teletherapy in the treatment of a patient with squamous-cell carcinoma of the middle ear. The prognosis in this rare tumor is grave. We previously treated these lesions with combinations of intra-aural radium and external radiation with 200-kv X rays. The patient shown in Fig. 7 had just completed a course of short SSD cobalt teletherapy with an exposure dose of 6900 r in air and a resultant estimated tumor dose of 6000 rads in five weeks through a single portal 5 cm in diameter. At the height of reaction there was very little to see (Fig. 7), but, when the crura of the helix were retracted, an intense moist reaction was

evident (Fig. 8). This is a graphic demonstration of the phenomenon of skin sparing, as well as maximum absorbed dose at a depth of a few millimeters beneath the skin surface.



Fig. 6—Same patient shown in Fig. 5, one month later (Sept. 1, 1954), after an exposure dose of 6000 r in air in four weeks. At the height of reaction the skin showed only a moderate erythema with pigmentation.

30 months after irradiation. In this patient cobalt teletherapy with a long SSD would only have achieved unnecessarily greater depth dose in the brain. With 200-kv X rays it is impossible to deliver 6000 rads



Fig. 8—Same patient shown in Fig. 7, with the crura of the helix separated to show intense reaction a few millimeters beneath the surface, as is characteristic of Co^{60} teletherapy.



Fig. 7—Carcinoma of the middle ear at the height of skin reaction after receiving an exposure dose of 6900 r in air in five weeks.

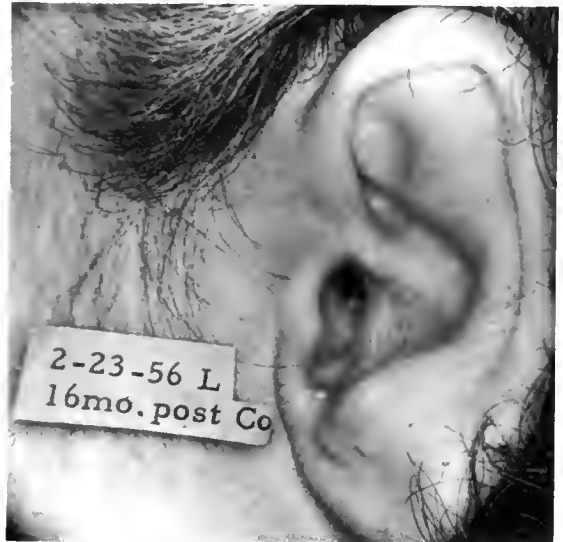

Fig. 9—Same patient shown in Figs. 7 and 8 after 16 months. The pinna is flexible and feels normal. There was no evidence of damage to subcutaneous tissue or cartilage in this short follow-up examination.

Figure 9 shows the pinna, normal in appearance, 16 months after the treatment. The patient is free of disease. The pinna is flexible, and there are no indications of subcutaneous fibrosis or cartilage damage

to a middle-ear tumor without a complex treatment plan and severely damaged adjacent tissue and skin.

We have irradiated 63 patients with breast cancer postoperatively. The internal mammary nodes were

treated with a single field measuring 5 by 12 cm. When the internal mammary nodes receive tissue doses of 4000 rads, the hilum of the lung receives less than 3000 rads.

Curable malignant tumors are not the only lesions suitable for short-distance therapy. Some important lesions also are suitable for palliative irradiation. As examples, I should like to cite 22 patients with carcinoma of the rectum, almost all these cases being recurrent in the hollow of the sacrum following abdomino-perineal resection. These patients are numerous since surgery for carcinoma of the rectum is not so uniformly successful as some persons suspect. Simple application of perineal and sacral fields results in palliation without skin reaction. A patient who has had a colostomy cannot tolerate the discomfort of the sacral skin reaction when enough 200-kv radiation is used to effect reduction in pain. As a result we rarely treated recurrent carcinoma of the rectum with 200-kv X rays, and then we gave only "token" doses.

The groin tolerates irradiation poorly because moist skin reactions limit effective dosage. With short SSD

Co⁶⁰ teletherapy the inguinal region may receive exposure doses of 6000 r in air in four weeks without difficulty. Radiation to this area with 200-kv X rays would be limited to about half that exposure dose because of intolerable skin reaction.

There is a strange paradox when Co⁶⁰ teletherapy and 200-kv X rays are compared for the treatment of superficial tumors. As indicated previously, deep tumors can be irradiated to a cancerocidal dose with 200-kv X rays by multiple portals or rotation, but superficial and accessible curable tumors are not so easily treated to doses in the cancerocidal range with 200-kv X rays.

The difficulty of treating metastases to cervical or inguinal neck nodes, parotid tumors, and thyroid cancers with high doses lies in the proximity of the tumor to the skin. In order to give the tumor 6000 rads, rotational or multiple-portal techniques with 200-kv X rays deliver similar doses to the overlying uninvolved skin. Such severe damage to the skin is usually avoided by the therapist with 200-kv apparatus by compromising on a lower dose.

Two Million Volt Therapy

CHAPTER 39

Magnus I. Smedal

Department of Radiology
Lahey Clinic
Boston, Massachusetts

I should like to describe briefly our local situation. We do not conduct X-ray therapy in any hospital except for an occasional case of superficial therapy. All cases are outpatients, either at our clinic building, where 220- and 400-kv X rays are available, or at Massachusetts Institute of Technology (MIT), where we are associated with Professor Trump and his colleagues in the High Voltage Laboratory of the Department of Electrical Engineering.

As a result of this association we have been working with 2-Mv X rays for the past seven years. All cases I shall show have been treated with a Van de Graaff machine. The output of the Van de Graaff at 125 cm, which is the axis distance we use, ranges between 60 and 70 r/min, usually about 65 r.

As time passes, we use the 220- and the 400-kv apparatus less and less. In fact, we use these machines for two major reasons: for the various non-malignant conditions seen every day in normal clinical practice and for the treatment of most of the lymphomas and metastatic lesions at the clinic because no other facilities and consultations are readily available.

We use the 400-kv machine for most of the metastatic carcinomas and the lymphomas, which we formerly treated with 220 kv. In other words, we prefer the higher voltage for everything. For years we treated Marie-Strümpell arthritis with 220 kv, but now we prefer 400 kv for the arthritic cases also. One of the reasons is that the 400-kv apparatus has a beam-defining mechanism that we like, and, since there is a skin-sparing difference with 400 kv, we prefer to use it for re-treatments.

As a result of less scatter with 2 Mv, beam definition is sharper, and compared to cobalt sources, although we have had no experience with cobalt, there is less penumbra, which makes 2-Mv X rays more desirable in some situations.

In addition to these physical qualities, the 2-Mv X-ray machines have been made very flexible for positioning; external beam definition particularly has been

made possible; field rotation is more practical and efficient. With field rotation using 200 kv, one of the greatest handicaps is the low output at the distance necessary to achieve rotation.

The high output of 2-Mv X-ray machines, with the resulting shorter treatment times, is important to those of us who treat only on an outpatient basis. Increased output makes it possible to increase the distance and the field size without unduly prolonging the treatment time.

At the clinic we have a very special situation; MIT is about 2 miles from the clinic building, and the clinic building has no beds. We are about 2 or 3 miles from the nearest hospital. Anything that makes treatment time short is of great importance in making treatment easier for the patient.

From a clinical standpoint, 2-Mv X rays are so superior to conventional X rays that the indications for 2-Mv therapy should be thought of in terms of the normal indications for deep X-ray therapy. In other words, whatever has been accomplished by 200 kv can be done better by using 2 Mv.

I should like to illustrate this attitude by showing representative situations, at the same time interspersing cases and comments on some of the complications that never resulted with 200-kv X rays.

Let me illustrate the skin-sparing properties of 2-Mv X rays. We have considerable short-term experience with lymphomas involving the skin, and, as you may know, these very superficial lesions have been well treated with cathode rays generated at 1.5 to 3 Mv.

Ulcerating lesions, however, which may have considerable thickness or depth, require more penetration, and we have found that X-ray therapy is necessary to heal them. Since most of these patients have had considerable irradiation at 100 kv before coming to us, we have felt it advisable to use higher energy radiation to obtain skin protection. Since both the cathode-ray machine and 2-Mv X-ray machines are at MIT, it is convenient to use 2-Mv X rays instead



Fig. 1—Mycosis fungoides before treatment (July 9, 1953).



Fig. 2—Same patient as shown in Fig. 1 after treatment with X rays and cathode rays (Sept. 11, 1953).

of other voltages for treating these deep lesions. The unit doses are of the order of 400 r once, twice, or three times. The same is true for recurrent Kaposi's sarcoma. Nearly all these patients have had 100-kv X rays by the referring dermatologist in amounts that seemed to prohibit further therapy.



Fig. 3—Kaposi's sarcoma before treatment.



Fig. 4—Same patient as shown in Fig. 3 after X-ray and cathode-ray therapy.

The success we obtain from 2-Mv X ray, therefore, is simply due to the fact that, instead of giving these lesions several doses of 60 or 100 r or single doses of 300 r at 100 kv, we give them doses of 400 r per treatment from one to three times using 2-Mv X rays. It is necessary to give at least 800 to 1200 r total dose to produce healing. Figure 1 shows a man with a very advanced case of mycosis fungoides. Smaller lesions heal well with cathode rays, but nothing will help the larger, deeper lesions unless X rays are used; and, as I said, we use 2-Mv X rays. We are limited to a maximum of 3 Mv in our use of cathode rays or electrons.

The results of the treatment, about two months later, are shown in Fig. 2. However, the lesions all recur sooner or later.

Figure 3 shows a case of Kaposi's sarcoma. Cathode rays at 1.5 to 3 Mv just do not reach lesions like these if they are deep and if they are situated between the toes; therefore we block off the anterior foot or the whole foot and give a single dose of 400 r with 2-Mv X rays.

Figure 4 shows the results of one or two doses of 400 r at 2 Mv. The patient had a large ulceration between the toes and on the soles of his feet which had not healed with cathode therapy at 2.5 Mv.

To illustrate further the skin-sparing properties of 2 Mv, I shall show two cases of breast carcinoma treated with a scanning technique designed to give the chest wall, axilla, and supraclavicular area a dose of 6000 r in seven weeks. The first case is that of a woman who had a radical mastectomy in February 1954. A wide skin excision was necessary, and a split-thickness graft was applied three weeks later on March 15. This healed in two weeks, and one month after grafting we started X-ray therapy, giving an average dose of 6000 r to the chest wall. At the completion of therapy (Fig. 5), there was merely a faint erythema of the normal skin; the area of the graft was slightly erythematous. It has been two years since this patient was treated. Another patient who had a breast graft has had a three year follow-up.



Fig. 5—Large skin graft after a 6000-r dose with 2-Mv X rays.

The skin looks normal in both patients. The graft is becoming pliable and is loosening up as if it had had no X ray. Three other patients with similar skin grafts have tolerated similar irradiation equally well.



Fig. 6—Recurrent breast carcinoma at start of 2-Mv X-ray therapy (July 22, 1955).



Fig. 7—Same patient as shown in Fig. 6 after 4000-r tissue dose with 2-Mv X rays (Feb. 9, 1956).

The second patient (Fig. 6) is a woman who had a recurrence in the left chest wall after a radical mastectomy for carcinoma. She also had positive nodes in the opposite axilla and supraclavicular region. Since there were no discernible distant metastases, we elected to treat both sides, both axillae, and the supra-

cylinder of irradiation. Only minimal erythema developed. Figure 8 shows the patient about six weeks after treatment. The ear is a little erythematous. Irradiation was started before the graft had completely healed; it healed during the period of treatment. The normal skin surrounding the graft is faintly ery-



Fig. 8—Epidermoid carcinoma of skin, invading ear and parotid. Patient had en bloc excision with skin graft. Photograph shows intact skin graft after 2-Mv rotation therapy, the dose being 6000 r in 44 days.

clavicular areas bilaterally with the same scanning technique. All areas were treated each day. Beginning in November 1955, a tissue dose of 4000 r in five weeks was administered with only slight erythema. The nodes subsided, and the chest-wall lesions regressed. At the completion of therapy (Fig. 7), the chest-wall masses and the axillary and the supraclavicular nodes were no longer palpable.

Another patient illustrating skin and cartilage tolerance to 2-Mv X ray was a middle-aged man with recurrent epidermoid carcinoma of the skin, which involved the ear and invaded the parotid. After a radical resection that did not reach beyond the tumor and after skin grafting, we gave 6000 r in 44 days through a field 7 by 9 cm with 360-deg rotation to produce a

themalous, the graft looks white, and the cartilage shows no reaction. There has been no further skin or cartilage reaction.

Another patient had an epidermoid carcinoma of the tonsil with cervical metastasis. She had been treated elsewhere with 200-kv X rays to the point of erythema (Fig. 9). She was given 6000 r more in six weeks through a field that covered not only the tonsillar area but also the entire right side of the neck and the supraclavicular area. This was also done by 360-deg rotation with a unilateral field to produce a unilateral cylinder. At completion of the therapy (Fig. 10) there was slight superficial denudation, a common reaction with 2-Mv X ray, and some tanning. The skin was dry. Six months later the skin was tanned, but it was pliable



Fig. 9—Epidermoid carcinoma of the tonsil; erythema from 200-kv X rays (November 1949).



Fig. 10—Same patient as shown in Fig. 9 after 6000 r with 2-Mv X ray and rotation (December 1949).



Fig. 11—Same patient as shown in Figs. 9 and 10 (May 1950).

and soft (Fig. 11). I saw her a few months ago, six years after X-ray therapy, and the skin has become lighter, soft, and pliable.

The next case is that of a 70-year-old man with epidermoid carcinoma of the nose. Eight months previously he had had nasal obstruction and an ulceration of the septum. The biopsy specimen showed inflammation. Two weeks before we saw him, the lesion had increased in size and was involving the entire nose. This was biopsied again and showed invasive epidermoid carcinoma. We first saw him on July 28, 1952, at which time an inflammatory lesion involved the entire nose, obstructed the nares, and ulcerated the septum. Radiographic examination showed only slight fuzziness of the spine of the maxilla. We gave fractionated irradiation through a single anterior port at the rate of 170 r/day at a target-to-skin distance of 75 cm. Eye blocks of steel protected the eyes. This setup will be shown later. This took seven weeks (Aug. 7 to Sept. 26, 1952). Figure 12 was made during the first week of treatment.

At 2500 r, halfway through the course of therapy, the lesion had shrunk tremendously (Fig. 13). There was a little dry reaction and a little pigmentation. Six months later the skin looked normal and was only slightly pigmented (Fig. 14). There was an ulcer in the septum. At the present time, three and one-half

years after treatment, the patient looks about the same as he looks in Fig. 14.

I do not wish to create the impression that all cases turn out as well as this. We have made errors in judgment.

The next case is that of an elderly man with a recurrent rectal carcinoma. A previous recurrence had been treated elsewhere, resulting in marked atrophy of the skin over the sacrum. When we saw him, he was again having considerable pain. Between October 25 and November 25, a tissue dose of 4000 r was given in 32 days through anterior and posterior opposing portals. At the 3000-r point he began to have a little superficial denudation in the mid-line in the old treatment area, but by the time we finished it was again healed. One month later the area of the old treatment field had again started to ulcerate. It was scarred, atrophic, telangiectatic, and tanned. Figure 15 demonstrates the tanning from our therapy. Unfortunately, about two months later the treatment field broke down still further, and he had local pain, although his pelvic pain was entirely gone. The entire old treatment area had to be excised to relieve the local pain. Probably a better result would have been obtained in this case if we had used rotation to spare the skin and assumed that 4000 r would not cause any internal damage. We did not take advantage of rotation,

INDICATIONS AND CONTRAINDICATIONS

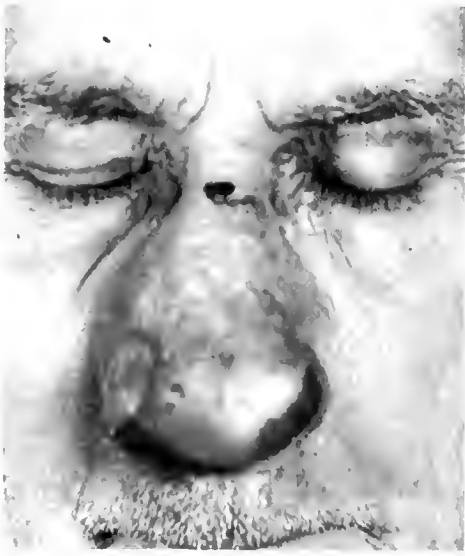

Fig. 12—Epidermoid carcinoma of nose in a man 70 years of age at start of therapy (Aug. 12, 1952).



Fig. 13—Same patient as shown in Fig. 12 after 2500 r with 2-Mv X rays (Aug. 26, 1952).



Fig. 14—Same patient as shown in Figs. 12 and 13 six months after 5440 r at 2 Mv (Mar. 12, 1953).

however, because we thought the field was large, about 12 cm wide.

The head and neck regions are areas where 2-Mv X-ray therapy has an advantage. Furthermore, 2-Mv X ray with rotation has altered the approach to pituitary tumors in our clinic. Before 1950, when 200-kv X rays were used for a dose of about 1800 to 2000 r to the sella turcica, 58 per cent of these patients returned for operation. Beginning in 1950, we used 2-Mv X rays with rotation and delivered a dose of 4000 r in four weeks to the pituitary area in chromophobe and chromophil tumors. The patients needing operation decreased to 18 per cent. In the cases that Dr. Gilbert Horrax surveyed, he considered 18 per cent too high an estimate because two of the cases that he explored after X-ray therapy had negative findings. He thought the incidence of X-ray failures should be between 10 and 15 per cent. Figure 16 is a portal film of the sellar area. The patient is positioned with the brow and the chin down and tied in position with polyethylene straps. This is a 4-cm field at the skin surface, which would be about 4.5 cm at the mid-line. Films are taken at the beginning of therapy and repeated during the treatment period for confirmation. We use silver nitrate on the skin to mark the center of the sella or tumor on each temporal surface, and



Fig. 15—Recurrent rectal carcinoma in a man 70 years of age. Previous treatment had consisted of conventional X rays plus 4000 r with 2-Mv X rays. Skin change corresponds to conventional X-ray field. The tanning is over the 2-Mv field.

we line up our fields every day on these two marks. The head is flexed for the X-ray beam to clear the orbits.

The skin receives only 10 per cent of the tumor dose, and therefore we do not see epilation except in

patients who have been treated previously. With a 5-cm field measured at the skin surface, a few patients had partial loss of hair at the temples, although the isodose curves indicated that the dose should not cause epilation. The hair usually starts regrowing in



Fig. 16—Two million volt radiograph of pituitary field.

about three months. Figure 17 shows the isodose curve and an X-ray film exposed in a phantom with rotation from which this curve is obtained. This is for a 3-cm field. It shows the steep gradient, or fall-off. The smaller the field the steeper the gradient. The curve for a 4-cm field is not greatly different.

Figure 18 is a radiograph of a chordoma that is visible in the nasopharynx. The patient was treated with a tissue dose of 6000 r in five to six weeks without loss of hair. The field size was a 4- by 6-cm rectangle on the skin, with 360-deg rotation to produce a cylinder of the same size centrally in the nasopharynx. Her only complication was some dryness in the nasopharynx, which has persisted for three years. There is no evidence of residual tumor at the present time, three years after therapy. Figure 19 shows the treatment field; note its sharp definition. With external definition and either lead or hevimet blocks, the beam can be made very sharp, and therefore we do not worry about getting too much radiation into the eyes.

[Author's Comment: Since this paper was presented, we have had three cases of nasopharyngeal carcinoma and one case of bronchogenic carcinoma treated to 6000-r tumor dose which developed spinal-cord paralysis one-half to two years after irradiation. We now believe that anyone receiving more than 5000 r into the cord area should have absolute cord protection.]

The next two cases illustrate the treatment of carcinoma of the frontal and ethmoidal sinuses. Figure 20 shows the beam-defining technique for a unilateral field. Inside the pot are lead shutters; outside is a face plate upon which we can hang all kinds of defining apparatus. These are steel blocks of different sizes and shapes which can be used to make any field shape desired. In addition, there is an external steel block with inserts of varying sizes and shapes to increase

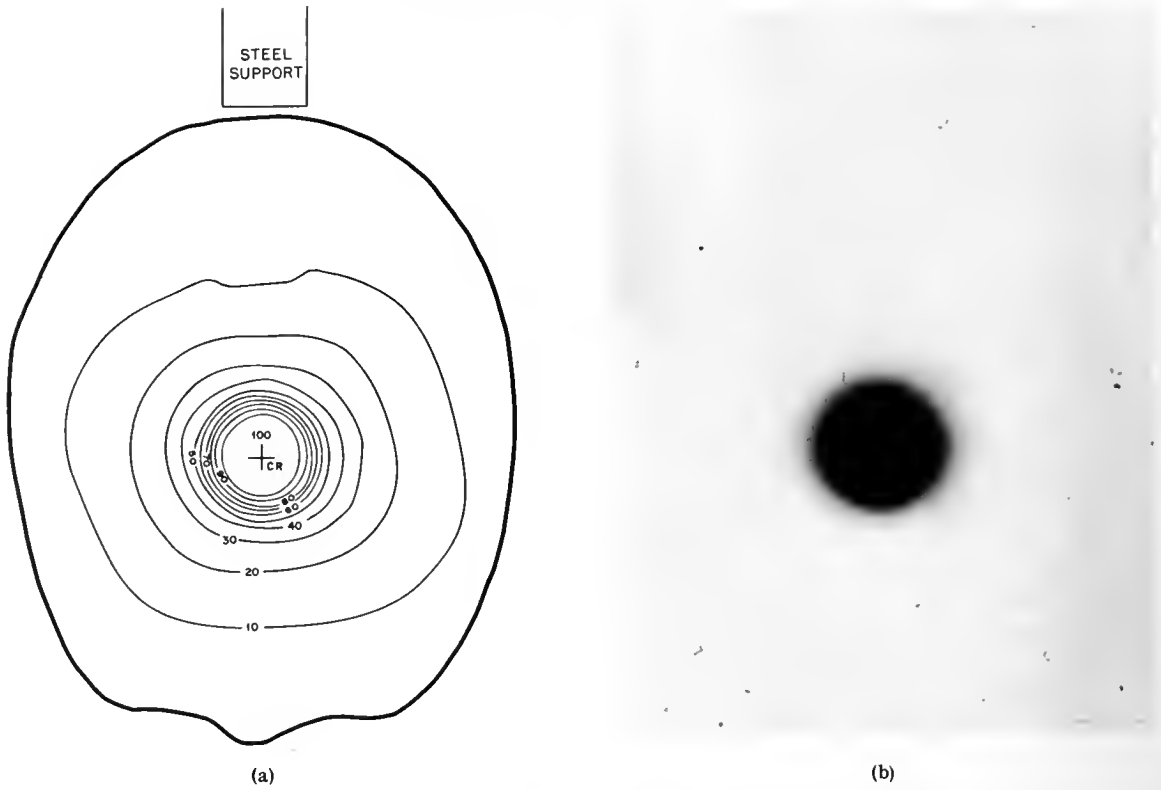

Fig. 17—(a) Two million volt isodose chart of a 3-cm pituitary field for rotational therapy (target-to-axis distance, 122 cm). (b) X-ray film exposed in the phantom from which curve was obtained.

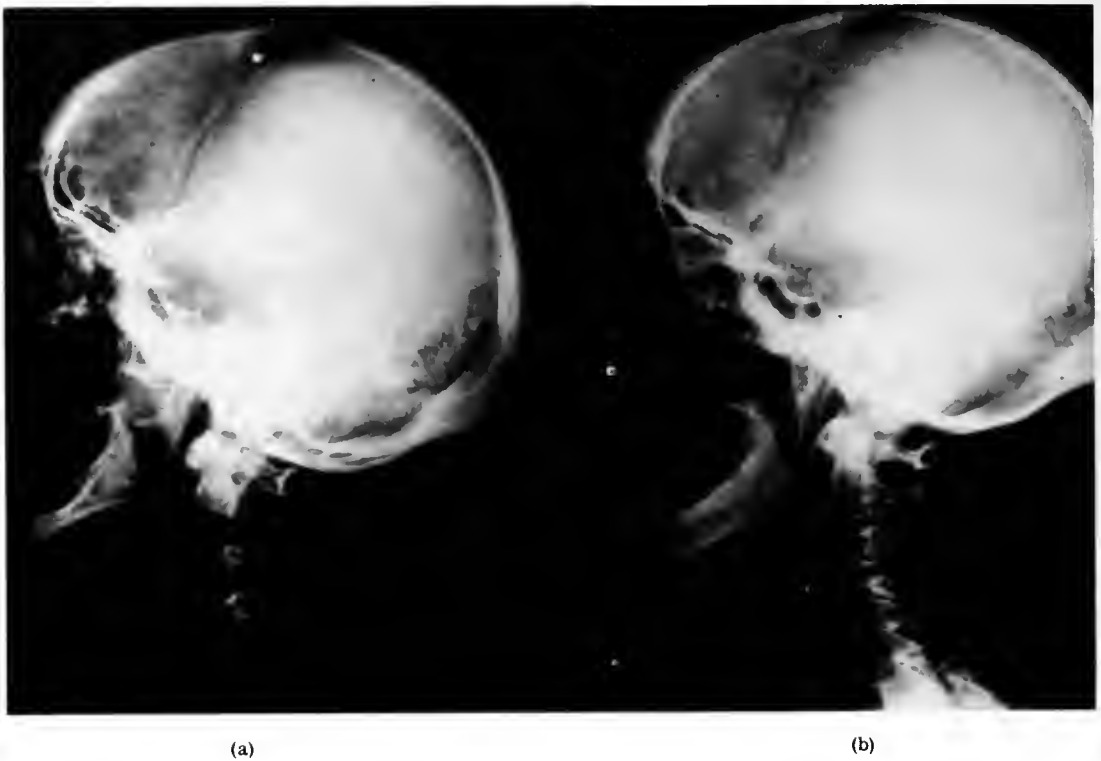

Fig. 18—Conventional radiograph of chordoma in nasopharynx. (a) Before 2-Mv therapy. (b) After therapy.

the sharpness of definition. To block out the eyes, we use a long cylinder of hevimet, which is called a hammer because of its shape. This cylinder, which is about 1.5 cm in diameter, casts a shadow in the X-

X-ray therapy, and Fig. 24 shows her appearance at its completion. These patients have a very mild conjunctivitis. This woman did not lose her eyelashes because they were well protected. The eye blocks



Fig. 19—Two million volt radiograph of treatment field of patient shown in Fig. 18.

ray beam, protecting the eye. The diameter of this protection will vary with the distance from the target.

Figure 21 shows how we first use our main beam-defining mechanism in the pot to define the over-all field. We then use external definition with the steel blocks, an extra hevimet block on the right side to block out the right eye very sharply, and then the steel cylinder to cover the area of the eyeball for protection from direct radiation. Figure 22 is a 2-Mv radiograph showing the resulting sharply defined field and core of protection afforded the left eye by the steel hammer.

The next case is that of a woman with epidermoid carcinoma involving the ethmoid sinuses on both sides, making treatment with a single anterior field and bilateral hammers necessary in order to protect both eyes. She received a 6000-r tissue dose in five weeks; the dose was measured to a depth back to the area of the sella because the ethmoid sinuses extend that far. Figure 23 shows the patient at the start of

transmit only about 2 per cent of the primary beam, and the scatter component into the eyes was estimated to be about 5 per cent, or 300 r. The eyes may therefore have received 550 r in five weeks. She did lose her eyebrows, but a year later a few eyebrow hairs had regrown. The swelling of the bridge of the nose has abated. The patient has had follow-up study for one and one-half years.

The next case is that of a man with a carotid body tumor in the right cervical area. When we first saw him, he had just completed a course of conventional X-ray treatment and had a marked reaction, with ulceration of the skin. The surgeons thought operative treatment inadvisable, and we would not treat him. He returned six months later, and the ulceration was healed. Since the carotid body tumor now extended to the left side, we treated both sides of the neck by rotation, giving 4500 r in five weeks to the entire area of the neck. Figure 25 was made at the completion of therapy and shows a dry reaction. Figure 26 was

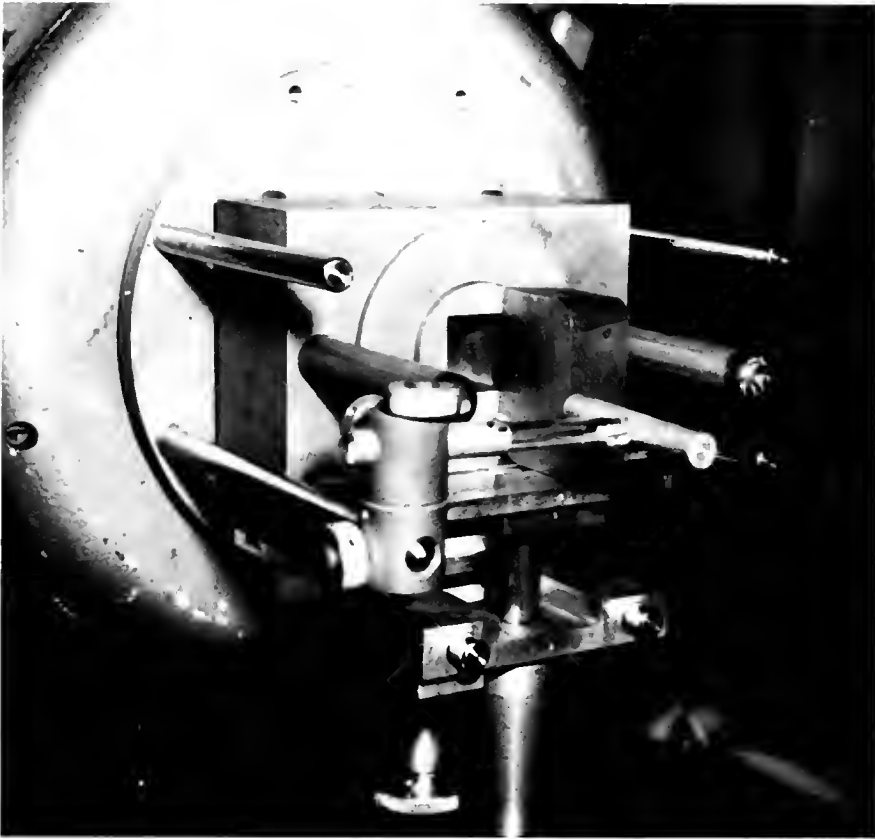

Fig. 20—Physical setup for treatment of sinus carcinoma. Note the eye block.

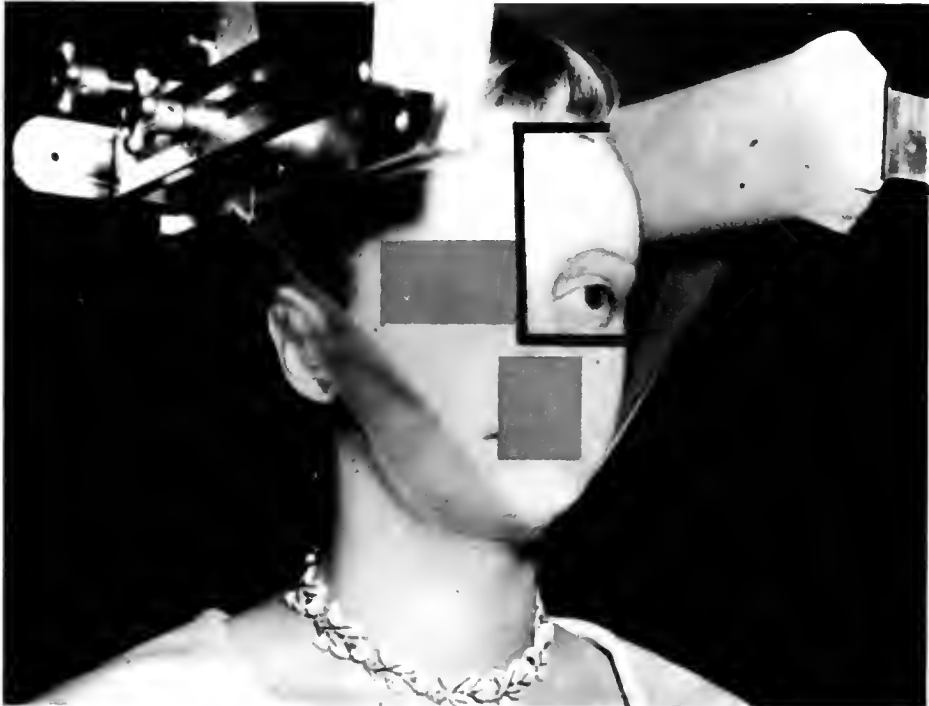

Fig. 21—Area of treatment using setup shown in Fig. 20.



Fig. 22—Same patient as shown in Fig. 21; 2-Mv radiograph of treatment field.



Fig. 23—Bilateral epidermoid carcinoma of frontal and ethmoid sinuses before therapy with a single anterior field.



Fig. 24—Same patient as shown in Fig. 23 at completion of 6000 r at a 5-cm depth with 2-Mv X rays in 34 days.



Fig. 25— Carotid body tumor, recurrent after surgery and conventional X ray, at conclusion of 4500 r with 2-Mv X rays with rotation.



Fig. 26— Same patient as shown in Fig. 25 one year later.

made one year later. The skin has remained intact. The lesion has been arrested for three years.

I should like particularly to show some mouth lesions. After irradiation of tumors of the naso-



Fig. 27—Radiation caries 18 months after X-ray therapy for nasopharyngeal carcinoma, showing indirect effect of radiation.



Fig. 28—Radiation caries 27 months after therapy for thyroid carcinoma (no primary beam on teeth).

pharynx and thyroid, the mouth becomes excessively dry because the salivary glands are included in the fields. We are particularly interested in the teeth in thyroid cases because many patients say that their teeth ache during therapy, and a few have had more cavities than usual.

The first case of this type is that of a man with a nasopharyngeal lympho-epithelioma. His posterior teeth were in the direct line of irradiation. He had no dental pain for 15 months. A few months later I noticed the first few cavities. Figure 27 was made 18 months after therapy. Three and one-half to four years have elapsed since treatment, and all his teeth are disintegrating. His front teeth did not receive direct X rays.

The second case is that of a woman treated for thyroid carcinoma. For thyroid carcinoma the X-ray beam enters below the chin; there is no direct X-ray beam to the teeth and certainly none to the upper



Fig. 29—Same patient as shown in Fig. 28 one year later, or 40 months after X-ray therapy for thyroid carcinoma.



Fig. 30—Fibrosis of soft parts with formation of constrictive band following dose of 6000 r in six weeks given to a bone sarcoma.

teeth. This patient began to complain of painful teeth and increased cavities about one and one-half years after completion of treatment. Figure 28 was made about 27 months after treatment. There was marked cavitation in all the teeth. They looked blue because of the numerous silver fillings in her mouth. Figure

29 was made one year later, at which time she was losing all her teeth. Radiation caries, which has been mentioned in earlier publications, is not necessarily due to direct radiation, as these two cases show. It is due to dryness of the mouth, and cavity formation is accelerated because of decreased salivation.

I have interested the Harvard School of Dental Medicine in this problem. They also think this condition must be due to the excessive dryness of the mouth. They have advised avoidance of sweets as long as the mouth is dry and a careful dental follow-up at least every three months for the first year after X-ray therapy and every six months thereafter.

Figure 30 illustrates the effect of high doses of X rays, 6000 to 7500 r, on the extremities. I have had three such cases, all involving the knee. If a complete

band or zone of the extremity is irradiated, a zone of marked fibrosis corresponding to the treatment field will result. Subcutaneous fat and subcutaneous tissue disappear, and the fibrosis forms a band around the leg, which causes considerable edema and is very painful. I have seen it on the upper extremities also, where the discomfort is less severe. In this patient it was necessary to amputate the leg because of pain. Care must be taken in treating the lower extremities to a dose that will produce severe fibrosis unless future amputation is contemplated.

In conclusion, we believe that 2-Mv X ray has opened new fields for better therapy and that anything that can be achieved with 200 kv can be done better with 2 Mv. We should not wish to return to 200-kv X ray exclusively.

Betatron Therapy

CHAPTER 40

Maurice Tubiana

Institut Gustave Roussy
Villejuif (Seine), France

Abstract

The use of 22-Mv peak-energy X rays of a betatron offers many technical advantages: great penetrating power and a low amount of scattered energy. This results in a high sharpness of the beam and a mass absorption coefficient nearly independent of the atomic composition of the tissue. Deep-seated tumors can be homogeneously irradiated with few fields. The tumor dose can be higher or the irradiated volume larger than with low-energy X rays. It is much easier to deliver a given dose in a given time to a deep-seated tumor than it is with lower energy X rays. This relative advantage increases with the depth of the tumor and the thickness of the patient.

The effect of these advantages upon survival have not yet been demonstrated; but the treatment is better tolerated, and there is no radiation sickness.

Introduction

Betatron therapy is indicated in cases where it can achieve better distribution of radiation than any other form of therapy. Optimum irradiation is here defined as the most homogeneous irradiation of the tumor-bearing volume, with minimum irradiation of the adjacent normal structures.

The physical advantages of betatron radiation are (1) the long range of the secondary electrons, which explains the shape of the depth-dose curve; (2) the low amount of energy scattered; (3) the low attenuation of the photon beam in tissues; and (4) the independence of mass absorption coefficient upon the atomic composition of human tissues.

Secondary Electrons

Secondary electrons are set in motion by photons during collision. With 200-kv X rays the average range of the electron in soft tissues is of the order of 0.1 mm, with a maximum range of 1 mm. At 22 Mv the maximum range exceeds 10 cm, and the electrons tend to travel directly forward.

When a beam of photons strikes tissue, the number of electrons set in motion in each successive layer

decreases according to the attenuation of photons (Fig. 1). The intensity of the flux of secondary electrons set in motion at a certain depth decreases quite rapidly, but the total flux builds up until the depth is reached where the number of electrons set in motion is equal to the number stopped. The density of ion pairs and the absorber dose are proportional to the flux of electrons. This maximum is reached at a depth of about 4 cm.

Scattering

Scattering ordinarily plays an important part in dose distribution. It explains the dependence of the depth dose upon the field area, the curved shape of the isodose curve, and the lack of sharpness of the edges of the beam.

We calculated and checked experimentally the relative importance of scattered radiation at 22 Mv. For instance, in a cylinder of 5 cm radius, the scattered radiation represents 10 per cent at 10 cm and 18 per cent at 18 cm, which is much less than it would be at lower energies (Fig. 2). The study of the build-up factor, which is the ratio of total dose over dose due to primary photons, could illustrate this fact. For a field surface of 200 cm² (Fig. 3), the build-up factor passes from 1 at the surface to only 1.2 at a depth of 20 cm. It increases slightly more with Co⁶⁰ and much more with 200 kv. Similarly, at a certain depth, the build-up factor increases much faster with the area of the field (Fig. 4) at conventional energies than at 22 Mv.

Besides the fact that much less energy is scattered at 22 Mv than at lower energies, the direction of these scattered photons makes smaller angles with the directions of incident photons. This contributes to the explanation of why the variation of the depth values with field area is very small. If the depth-dose values are expressed as a percentage of the maximum, the variation is negligible (Fig. 5). The variation would be greater only if the depth-dose value for the same X-ray flux is considered. The low scattering also

explains the shape of isodose curves, which is different from those obtained at lower energies. One of the most important features of the isodose curves obtained with betatron radiation is that the curves are nearly perpendicular to the axis, even at great depths. The flatness of the isodose curves permits a smaller field than is used in conventional therapy (Table 1).

The sharpness of the edge of the beam and the fact that a homogeneous tumor dose can be achieved with a smaller number of fields explain the possibility of irradiating the tumor-bearing volume in the immedi-

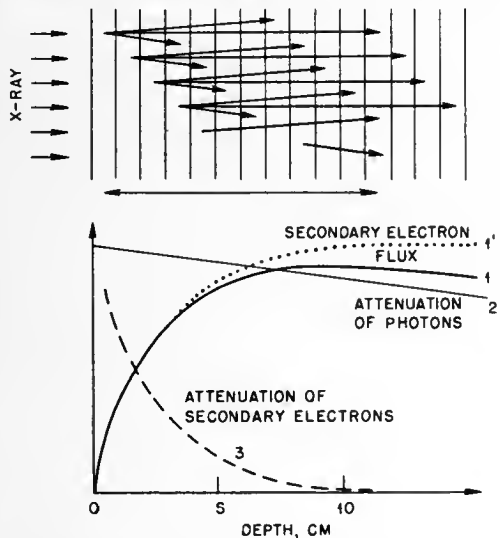

Fig. 1—Build-up to equilibrium of total flux of electrons, although the number of secondary electrons decreases with photon alternation.

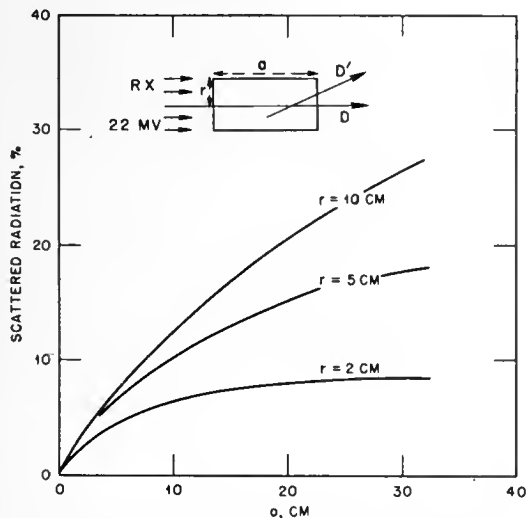

Fig. 2—Relative importance of scattered radiation in cylinders with radii of 2, 5, and 10 cm.

ate vicinity of normal structure to be protected. It is possible to treat a cancer of the esophagus without irradiating the spinal cord (Fig. 6).

Attenuation

The central-axis depth-dose curves illustrate the slow attenuation of the betatron X-ray beam (Fig. 7). It is obvious that, with 22 Mv, a dose could be delivered

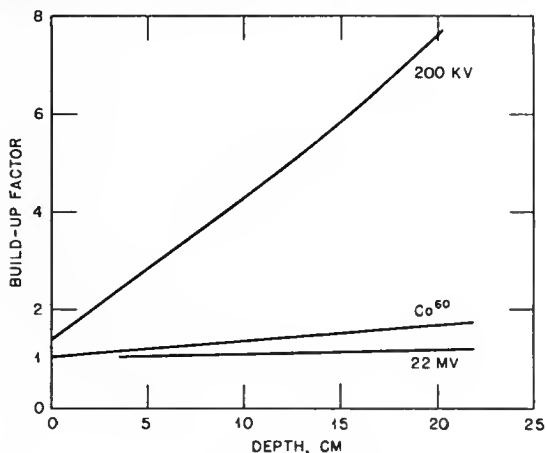

Fig. 3—Difference in build-up at three different energies (SSD, 100 cm; field, 200 cm²).

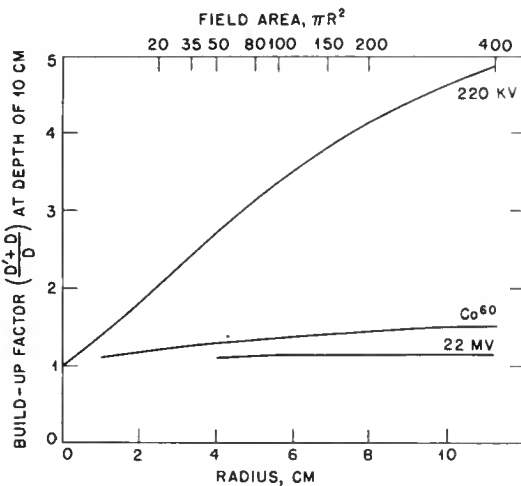

Fig. 4—Rapid increase of build-up factor at low energies and a slower increase at high energies. D', dose due to scattered radiations, D, dose due to primary radiations. For 220 kv, the half-value layer (HVL) is 2 mm of copper, and the FSD is 60 cm. For Co⁶⁰, the FSD is 60 cm. For the 22-Mv betatron, the FSD is 100 cm.

to a deeply situated point with less radiation to the tissues interposed between the skin and the tumor. The tissues located beyond will receive a little more, but the over-all advantage remains important.

The ratio of maximum dose to tumor dose varies much less with the depth of the tumor at 22 Mv than it does at lower energies (Fig. 8).

Another way of expressing the reduced irradiation of the overlying and underlying layers of normal tissue for a same tumor dose is to calculate the integral

Table 1 — COMPARATIVE FIELD SIZES*

Apparatus	Field diameter for a 5-cm tumor diameter, cm		Field diameter for a 10-cm tumor diameter, cm	
	At surface	At tumor	At surface	At tumor
220-kv machine (HVL, 1.5 mm of copper)	7	8.2	14	16
Co ⁶⁰ (source-collimator distance, 26 cm)	7	8.2	12	14
Co ⁶⁰ (source-collimator distance, 46 cm)	6	7	10	12
Betatron	4.3	5	8.5	10

*To obtain a homogeneous dose distribution, within ± 5 per cent, on every point of the section of a tumor located at a depth of 10 cm and having a supposed diameter of 5 or 10 cm, a certain area of the beam is necessary. This area decreases when the energy of the X rays increases. The size of the field is increased according to the amount of penumbra.

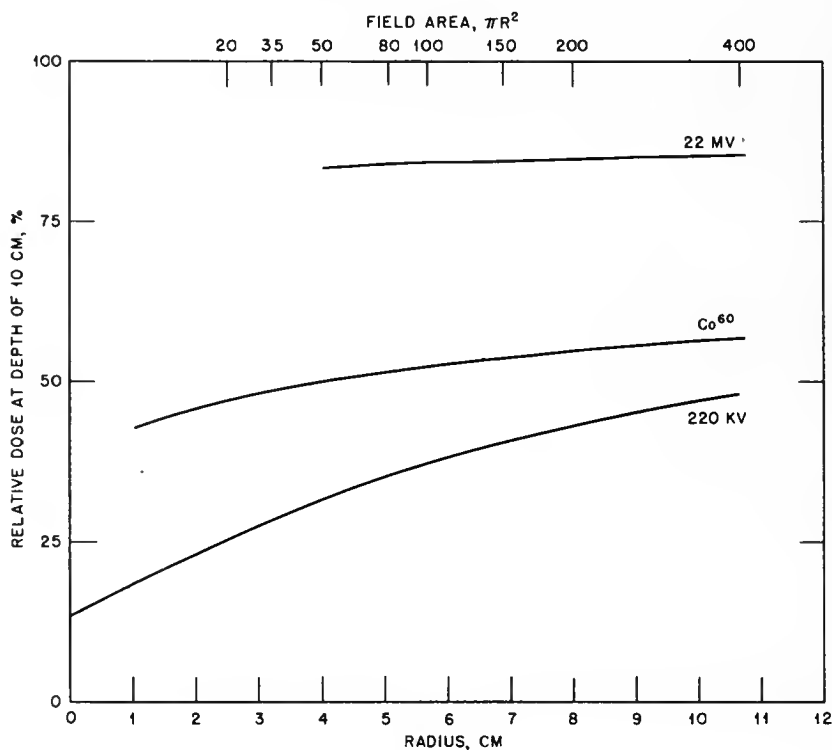

Fig. 5—Depth dose at 10 cm expressed as a percentage of maximum dose. For the 22-Mv betatron, the FSD is 100 cm. For Co⁶⁰, the FSD is 60 cm. For 220 kv, the HVL is 2 mm of copper, and the FSD is 60 cm.

dose. For a given patient and identical fields, the part of the integral dose absorbed by the normal tissues decreases when the penetrating power of the X ray increases (Fig. 9). In thick patients the ratio of tumor dose to integral dose would be slightly better with 100-Mv X rays than with 22 Mv. The average dose to normal tissue is similarly reduced at high energies. The advantages of the betatron beam are increased

with the depth of the tumor and the thickness of the patient (Fig. 10).

In this comparison of integral dose the advantage of the betatron has been somewhat underestimated because the comparison was made on the basis of fields of the same size. As we have seen (Table 1), it is necessary to use larger fields or a greater number of fields with 220 kv and cobalt to obtain a comparable

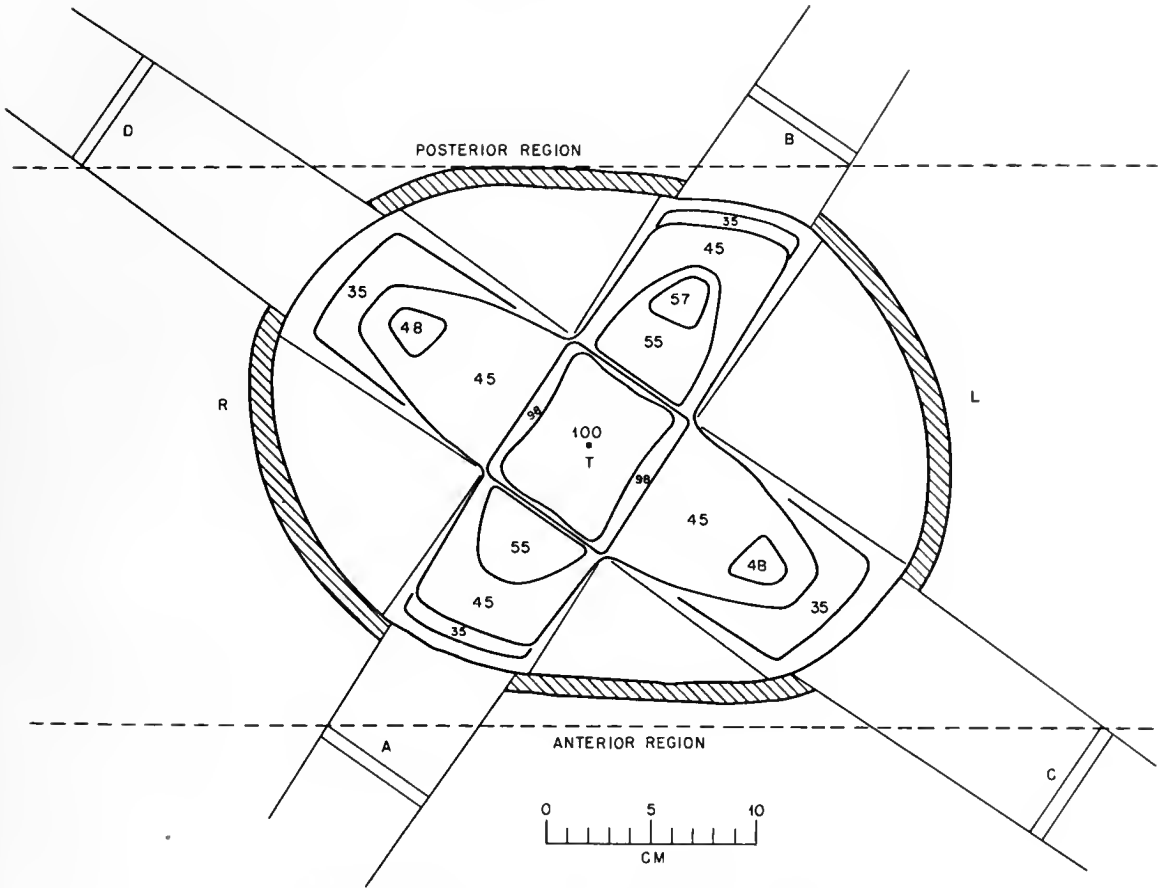

Fig. 6—Isodose curves for an esophageal treatment plan.

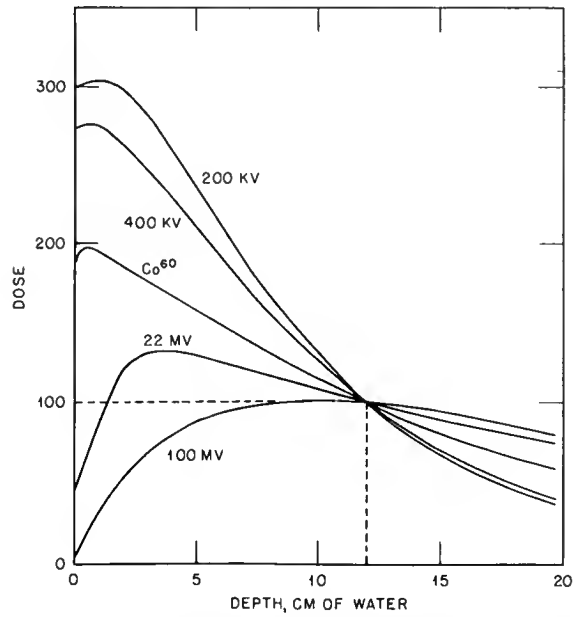

Fig. 7—Relative central-axis depth dose for various energies.

homogeneous dose to the tumor. The differences of integral dose per unit of tumor dose are more important in actually planning treatment for a given patient with different qualities of X rays (Table 2). The low integral dose results in low radiation sickness.

Table 2—INTEGRAL DOSE PER UNIT OF TUMOR DOSE FOR DIFFERENT ENERGIES

Energy	Field	Integral dose for 1 r at center of tumor, g-rads
220 kv	Three, 8 × 15 cm One, 10 × 15 cm	7.400
Rotation therapy	240 deg with field area of 6 × 15 cm	4.900
Co ⁶⁰	Four, 8 × 12 cm One, 8 × 10 cm	4.400
22 Mv	Two, 8 × 10 cm	2.500

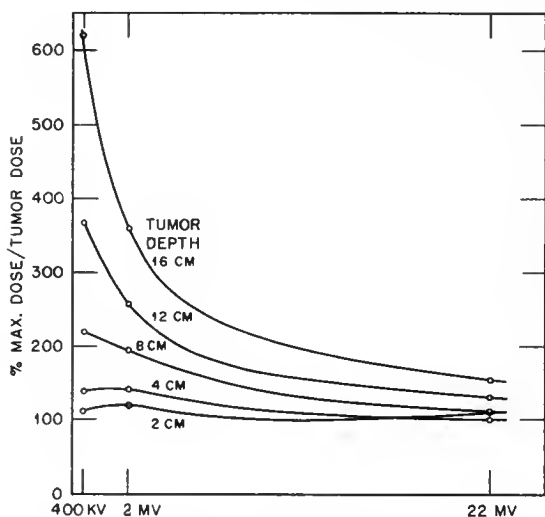

Fig. 8—Ratio of maximum dose to tumor dose at various energies and for various depths of tumor.

Tissue Heterogeneity

The heterogeneity of the irradiated tissues can be easily corrected. Owing to the small amount of side-scattering, each portion of the betatron beam can be considered independently. The transmission through a thorax was measured in eight patients and on each patient along seven different axes of the beam (Fig. 11). Curve 1 is the dose transmitted through the patient and is modified by varying densities such as bone ($d = 2$) and lung ($d = 0.5$). Curve 2 is the dose transmitted through a homogeneous phantom made of rice.

Transverse stratigraphy gives pictures without any distortion of the cross section of the patient at the same level (Fig. 12). It is then possible to estimate the length of the path of the beam through soft tissues, lung, and bone. For each patient, measurements were also performed through the cast in which the patient

was irradiated, filled with a homogeneous material of density 1. The results agree very well with theoretical attenuation (Fig. 11, curve 2) in a density 1 medium.

The isodose curves plotted without consideration of the heterogeneity of the tissue (Fig. 13) are now corrected for using these transmission coefficients (Fig. 14).

Mass Absorption Coefficient

With 200-kv X rays the photoelectric effect has great importance, resulting in large absorption in materials of high atomic number. The contribution of the Compton effect is predominant with betatron X rays. Thus, in a human body mass, the absorption coefficient is nearly the same for all tissues.

In 200-kv therapy, bone is a problem because (1) soft tissues included in bone are particularly affected by radiations and (2) bone acts as a screen for underlying tissues.

Soft Tissues in Bone

With betatron X rays, calculations taking into account the complete photon spectrum show that the energy transferred to 1 g of bone is approximately equal to the energy transferred to 1 g of muscle or water. Although pair production depends on the first power of the atomic number (Z^2), so that differences between materials of different atomic numbers could appear, its contribution is small (about 10 per cent). Owing to the long range of the secondary electrons, the electronic flux in a cavity filled with soft tissue inside the bone is the same as that in bone. We calculated and also found experimentally that the ratio of the number of ionizations in a small air cavity inside bone or water for the same roentgen flux is 1.14.

The absorbed dose in soft tissue within bone is therefore 1.14 times the absorbed dose in soft tissue outside bone. In fact, the difference is even smaller because the dimensions of the compact bone are relatively small in comparison with the ranges of the electrons. In a human body, a great number of electrons going through a Haversian cavity in bone are set in motion not in the surrounding hard bone but in soft tissue.

Practically, there is no difference between the dose absorbed in bone or soft tissue, and there is no difference between Co⁶⁰ and betatron radiation from the point of view of preferential energy absorption.

Bone as a Screen for Underlying Tissues

With 200 kv, high absorption in bone reduces the dose delivered to tissues located beyond a layer of bone (Fig. 15). With Co⁶⁰ energy the mass absorption coefficient is the same in bone and soft tissue, but, owing to the high density of hard bone (1.85), the linear attenuation coefficient nearly doubles. A similar phenomenon occurs for betatron energy, but, since the attenuation is smaller, the effect is less important.

BETATRON THERAPY

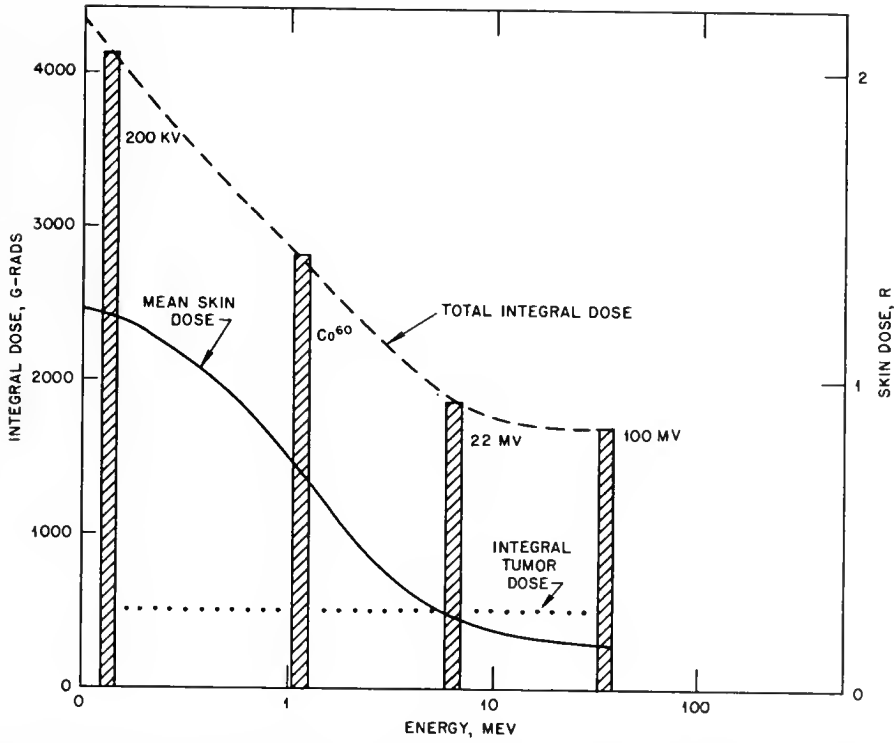

Fig. 9—The relations of integral dose to skin dose and tumor dose. Doses are for 1 rad at the tumor center.

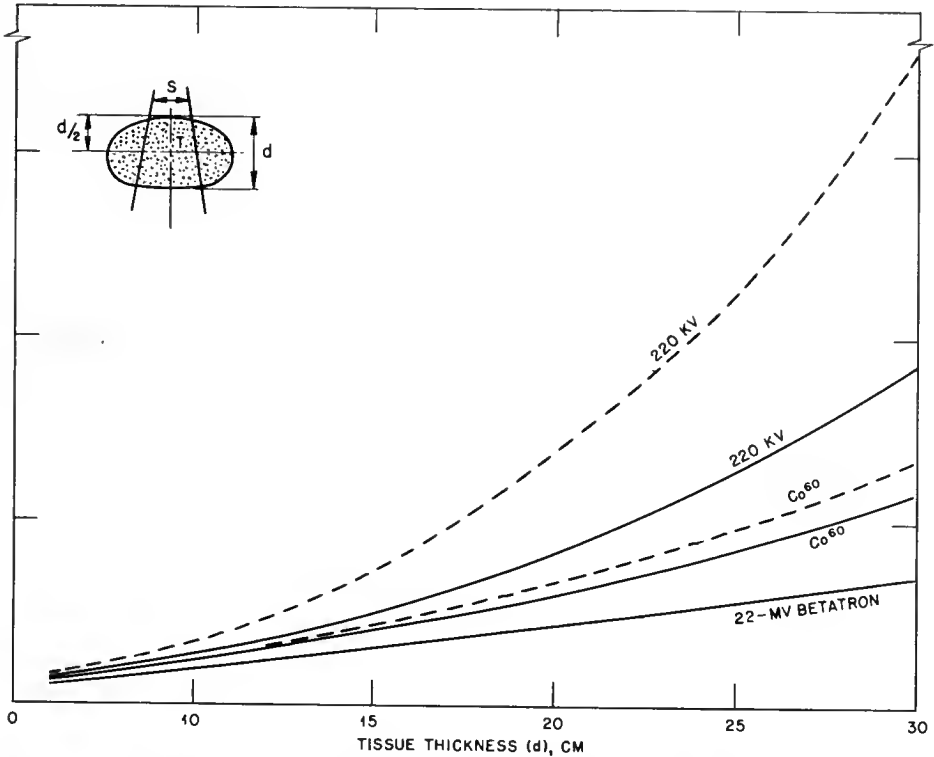

Fig. 10—The integral dose at various energies as related to tissue thickness. For 220 kv, the HVL is 2 mm of copper, and the FSD is 60 cm. For Co^{60} , the FSD is 100 cm. ---, $S = 20 \text{ cm}^2$; —, $S = 100 \text{ cm}^2$.

For instance, with a circular beam of 10 cm diameter, a 2-cm-thick layer of hard bone reduces the depth dose with 200 kv by 45 per cent (a 2-cm layer of soft tissue would reduce it by only 23 per cent); with Co^{60} , by 20 per cent (11 per cent for the same layer of soft tissue); with the 22-Mv betatron, by 9 per cent (4 per cent with soft tissue).

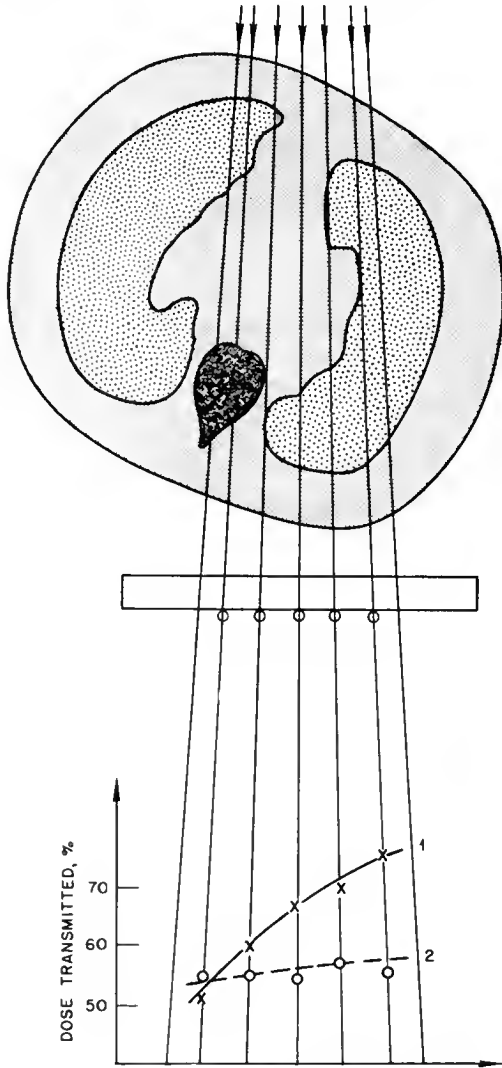

Fig. 11—Measurement of transmission dose through a thorax by means of an ion chamber.

Skin Reaction

The mild skin reaction is an advantage that some investigators consider of doubtful value. The 22-Mv betatron avoids severe skin trouble and facilitates subsequent surgery. Conversely it deprives the radiotherapist of an index that might be of value if there is a correlation between the skin and the tumor reactions.

Minor Advantages

A few minor advantages of the betatron are the small focal spot, resulting in a low penumbra, the high out-

put, and perhaps the psychological effect resulting from the dimension of the machine and its roar.

Relative Biological Efficiency

One of the difficulties with betatron radiation is the uncertainty about the relative biological efficiency (RBE), which may depend on two factors: (1) the linear energy transfer (LET) and (2) the pulsating nature of the beam, which results in very high instantaneous intensity. The duration of the pulse is 5 μsec , and, when the rate is 100 r/min, it corresponds to 100 r in less than $\frac{1}{100}$ sec. The influence of this last factor is not yet well known.

Radiobiological experiments have shown the clear influence of LET on RBE, although they are not proportional. The value of LET, the ion density, is a function of the kinetic energy of the ionizing electrons, and along the track of an electron the LET varies with its instantaneous energy. The spectral distribution of electrons at a certain depth in a medium can be calculated, and the distribution of ion track can be determined. Knowing the distribution of LET, one can calculate its mean value. It passes from 2000 ev/μ for 200-kv X rays (which corresponds to an ion density of 60 ion pairs/ μ) to 220 ev/μ for 22-Mv X rays (which corresponds to an ion density of 7 ion pairs/ μ) (Table 3). The mean LET is not sufficient to describe the transfer of energy along the tracks of the electron, which has a broad spectrum of different possible values. In fact, the LET varies from a minimum of 185 ev/μ , which occurs for electrons of 1 Mev energy,



Fig. 12—Transverse stratigraph to estimate the length of the path of photons through the chest.

to more than 400, 2300, and 12,000 ev/μ for 100-kev, 10-kev, and 1-kev energies, respectively, and to slightly more than 200 ev/μ for energies higher than 10 Mev.

BETATRON THERAPY

For some effects, such as certain chemical reactions, the ionizing particles with a LET higher than 25,000 ev/μ (which corresponds to electrons of

The difference of LET would explain a difference of RBE between 200-kv X rays and betatron X rays, but all the calculations show that with respect to LET

Table 3 — MEAN VALUE OF LET

Radiation	Effective mean energy	Number of ion pairs per micron track in water (approximate)	LET (approximate), ev/μ
220 kv (HVL, 1.5 mm of copper)	100 kev	70	2300
(HVL, 2.2 mm of copper)	120 kev	60	2000
1000 kv (HVL, 9.5 mm of copper)	500 kev	15	500
Radium gamma rays	0.8 Mev	10	300
Co ⁶⁰ gamma rays	1.2 Mev	8	250
22 Mv	7 Mev	7	220

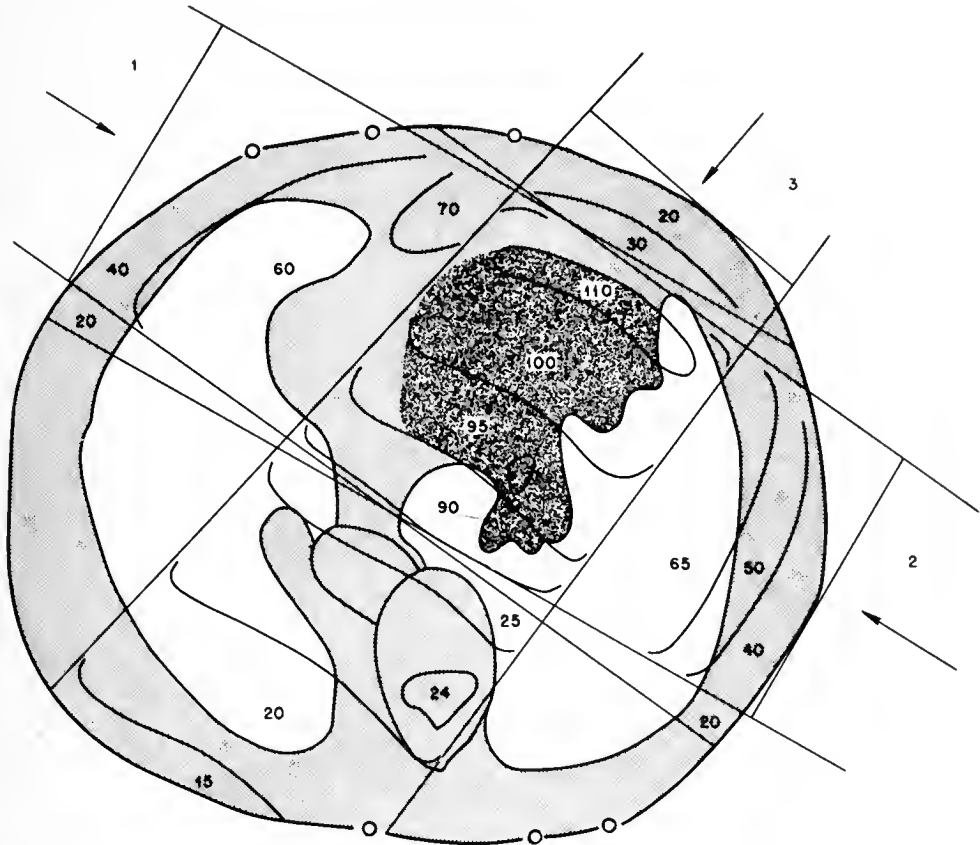

Fig. 13—Isodose curves plotted for homogeneous tissue. Fields 1 and 2: 8 by 10 cm at 80-cm SSD (calculated) but used at 100-cm SSD. Field 3: 8 by 10 cm at 80-cm SSD (calculated) but used at 95-cm SSD.

instantaneous energy smaller than 0.5 kev) have much greater effectiveness than particles of smaller specific ionization. The energy transferred to the medium with such a great rate of energy loss is a little over 0.2 of the total energy transferred with 200-kv X rays and a little less than 0.1 for betatron X rays, taking account of the instantaneous rate of energy loss along the tracks of secondary electrons and of all the tertiary and other electrons set in motion by the secondary electrons (delta rays).

we should not expect these differences between Co⁶⁰ gamma rays and 22-Mv X rays.

These considerations are rather theoretical. In fact, experiments performed on mammals do not show great differences in RBE. From a medical point of view, the only RBE of interest is the therapeutic effectiveness. All investigators agree on some reduction of the therapeutic effect for the same tumor dose, but there is much controversy about its importance. It seems to be of the order of 15 per cent but can be

accurately estimated only by systematic treatment of larger series of comparable patients with a given tumor dose. In any case, the apparently small difference between the RBE of high energy and that of con-

with 220-kv X rays and 22 with betatron X rays. For a given tumor dose the reduction is less with betatron. However, for a given integral dose the reduction is about the same in both cases (Fig. 17).

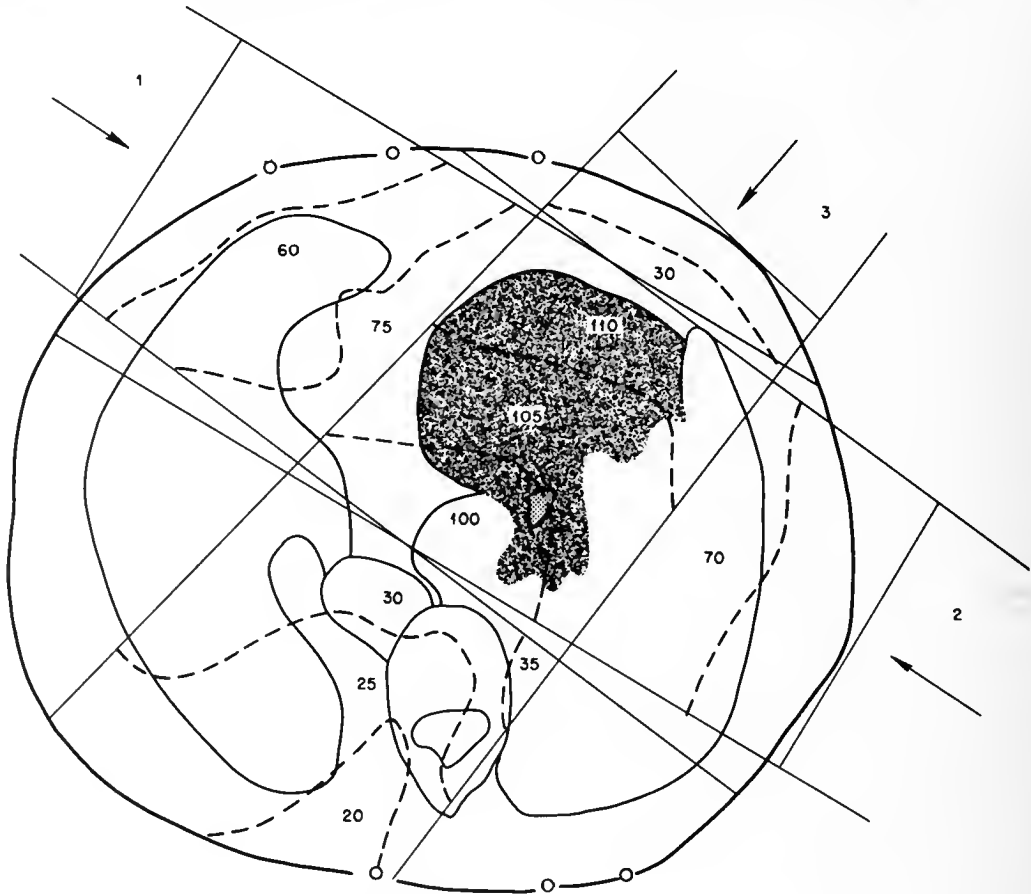

Fig. 14—Isodose curves plotted for heterogeneous tissue (same as Fig. 13.).

ventional therapy does not justify the restriction of the use of this therapy to hopeless cases. It may have been prudent a few years ago to treat only advanced cases with the betatron; it is not so any longer, and the limitation of this therapy to advanced cases could lead to wrong impressions. The response of a very big tumor irradiated with a large field and that of a small tumor irradiated with a small field can hardly be compared. The differences of local vascular conditions and of the general condition of the patient forbid any extrapolation of the information obtained from very large tumors to curable cases.

Summary of Betatron Therapy

Since November 1953, we have treated 173 patients (Table 4).

Our observations confirm that the radiation sickness and the blood changes are much less important than they are with conventional X rays. Figure 16 compares the relative average number of leukocytes in two series of cancer of the esophagus, 16 treated

We have never observed any serious radiation sickness or serious blood change. From this point of view high-energy X ray facilitates greatly the work of the radiotherapist. Furthermore, since radiation sickness is negligible, it is possible (1) to increase the tumor dose in cases where the general reaction of the patient

Table 4—BETATRON THERAPY

Localization	No. of patients	Tumor dose, rads
Cancer of the esophagus	56	6000
Lung	56	5500
	26	7500
Base of the tongue	27	7500
Bladder	8	7500

is the limiting factor; (2) to increase the irradiated volume in the same circumstances; and (3) to have any combination of these two factors.

BETATRON THERAPY

Table 5 — CANCER OF THE ESOPHAGUS

Location	Dose (rads)/ time (weeks)	Survival, months	Residual tumor	Metastasis below diaphragm		Injury	
				Nodes	Liver	Myocardium	Lung
Lower third	6000/6	3	0	+	0	+	+
Lower third	5500/8	2	+	+	0	+	+
Lower third	6000/4	2	0	+	+	+	+
Middle third	6000/6	5	+	0	0	0	±
Middle third	6000/8	5	+	0	0	±	±
Middle third	5100/4	14	+				
Middle third	6000/8	8	+	0	0	0	0
Lower third	5200/7	4	+	+	0	0	0
Lower third	6000/8	12	0	+	+	0	0

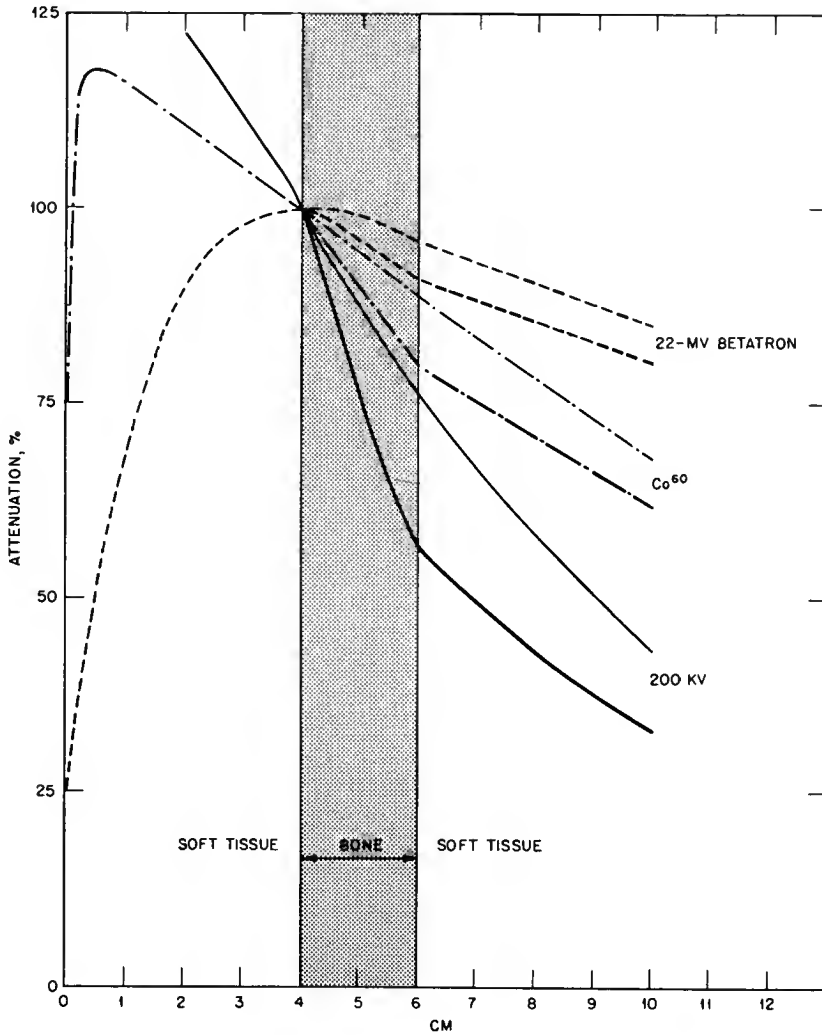

Fig. 15— The effect of bone absorption at various energies. - - -, 22-Mv betatron. — . — ., Co^{60} . —, 200 kv; HVL, 1.5 mm of copper.

Requirements for Use of the Betatron

The sharpness of the betatron beam requires such accurate aiming that it necessitates an accurate determination of the limits and the position of the tumor. It also requires a good beam-direction device and a highly accurate and reproducible method of positioning the patient. Our patients are always immobilized in plastic casts during beam directioning and irradiation. Front and back pointers are used.

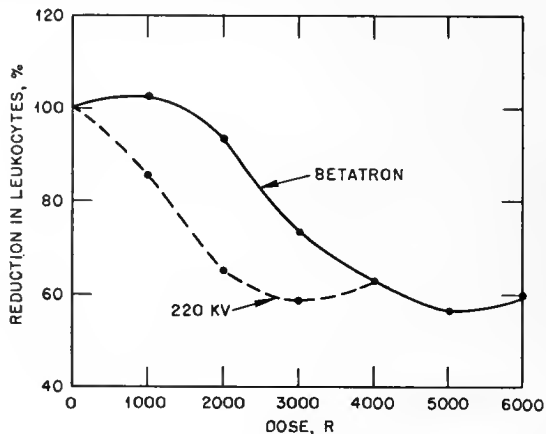

Fig. 16—Relative reduction in leukocytes in patients treated with the betatron and patients treated with 220 kv, tumor dose being used as the unit of comparison (see Fig. 17).

Cases Treated with the Betatron

Esophagus Cancer

We have treated 56 patients with cancer of the esophagus. A tumor dose of 6000 rads was delivered in six to eight weeks to the entire thoracic esophagus (24 cm). During treatment, which was well tolerated, and immediately after there was definite improvement of the general condition of the patients. The average survival time was 10 months. A local recurrence was observed in 10 cases and was probable in 7 other cases. Three fistulae of the esophagus were observed during the two months after completion of treatment.

Nine post-mortem examinations were performed (Table 5). Local sterilization was complete in only three cases. In all five cancers of the lower third of the esophagus, metastatic nodes were discovered under the diaphragm. In four cases a fatty infiltration of the heart was observed (three moderate and one very slight). Pulmonary and bronchial sequelae observed in five cases were very slight.

Lung Cancer

The first 56 patients with lung cancer received a tumor dose of 5500 rads; the following 26 received 7500 rads. The immediate results were not significantly different in these two series. Twenty-five of the patients were living 12 months after the treatment.

Five post-mortem examinations were performed. Four fatty infiltrations of the myocardium and one pericarditis were found. In two cases local destruction of the tumor was complete (Table 6). Radiotherapy was followed by surgery in eight cases (Table 7). Only one patient showed no residual cancer. In seven cases a few cancer cells were found in necrotic and fibrotic tissue. In one case the cancer was still in active state. Total paraplegia occurred in one case eight months after the end of the treatment (the dose to the spinal cord was estimated to be 4000 rads in four weeks).

Cancer of the Bladder

Eight cases of cancer of the bladder were treated with a tumor dose of 7500 rads. In one case, cystectomy performed a few months after the end of the treatment enabled us to verify the total destruction of the tumor.

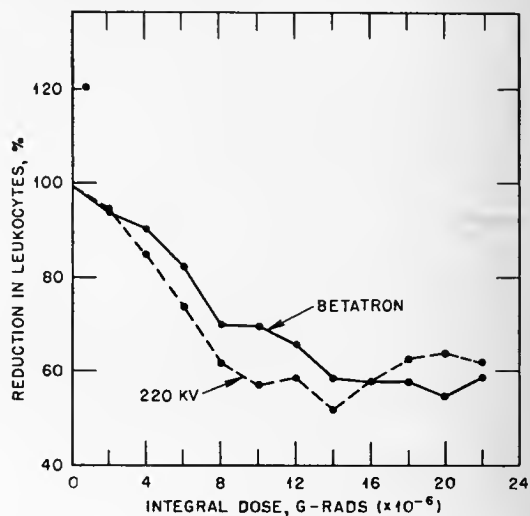

Fig. 17—Relative reduction in leukocytes in patients treated with the betatron and patients treated with 220 kv, integral dose being used as the unit of comparison (see Fig. 16).

Cancer of the Base of the Tongue

Twenty-seven patients with cancer of the base of the tongue received 7500 rads in eight weeks. The immediate local results were strikingly good, but local and lymphatic recurrences were frequent.

Indications for Betatron Use

In conclusion, betatron X rays permit easy treatment of deep-seated tumors. The relative advantages increase with the depth of the tumor and the thickness of the patient. The most specific advantages appear to be for deep tumors located near radiosensitive structures that should be protected.

There is no point in using such a complicated apparatus for superficial tumors or for cancer that requires spray irradiation of a large portion of the body.

BETATRON THERAPY

Table 6—LUNG CANCER

Dose (rads)/ time (weeks)	Survival, months	Residual tumor	Metastasis	Heart injury	Other injury
6000/8	11	0	0	Pericarditis	0
5400/6	6	0	Supraclavicular nodes	Fatty infiltration of myocardium	
6000/4	21	+	0	Fatty infiltra- tion	Paraplegia
5000/6	5	+	0	0	0
7500/8	6	+	Liver	Fatty infiltra- tion	0
5500/7	6	+			0

Table 7—LUNG CANCER PLUS SURGERY

Dose (rads)/ time (weeks)	Interval between end of radiothera- py and surgery	Surgical findings			Survival, months
		Excision	Macro*	Histol.†	
5200/9	4 months, 2 weeks	Poss.	D	0	22
5100/6	7 weeks	Imposs.	No R	+	10
5400/9	9 months	Poss.	R	+	22‡
7500/8	2 weeks	Poss.	D	+	4‡
7500/8	2 weeks	Poss.	R	+	4‡
7500/8	6 months	Poss.	D	+	6
7500/8	2 months, 1 week	Poss.	D	+	9‡
7500/7	2 weeks	Poss.	R	+	4‡

*D, disappearance of the tumor; R, regression.

†Histol.: +, tumor cell; 0, no tumor cell.

‡Still living.

Cancer of the base of the tongue, esophagus, lungs, uterus, and bladder seem to be good indications. The stomach, pancreas, and rectum are worth trying in spite of their reputation. Tumors of the brain present an interesting indication, although we do not have any personal experience in their treatment.

References

1. J. S. Laughlin, "Physical Aspects of Betatron Therapy," Charles C Thomas, Publisher, New York, 1954.
2. H. E. Johns, X-rays and Teleisotope γ -rays, in "Radiation Dosimetry," Chap. 12, pp. 531-596, edited by G. J. Hine and G. L. Brownell, Academic Press, Inc., New York, 1956.
3. Joyet, Trumpl, Eggenberger, and Manderli, "The Brown Boveri Betatron," p. 36, Brown, Boveri & Company, Limited, Eaden, Switzerland, 1953.
4. M. Tubiana, J. Dutreix, B. Pierquin, and P. Jockey, Conditions pratiques d'utilisation médicale d'un bêta-tron de 22 MeV, J. radiol. et électrol., 36: 507-522 (1955).
5. M. B. Tubiana, B. Pierquin, J. Dutreix, and P. Jockey, Discussion of A. Zuppinger, "Berner Erfahrungen mit dem Betatron," pp. 346-368, Radiol. Clin., 24: 371-381 (1955).

DISCUSSION

CHAPTER 41

Kelly: Dr. Tubiana presented a paper on a type of therapy with which I am least familiar. Perhaps the one thing that impressed me was the rather high dosage delivered to a limited field with very little scatter about it, indicating that, if we think we have been sharpshooters with other methods of therapy, we shall definitely have to be much more accurate in determining the extent of the lesion if we hope to use betatron therapy successfully.

Retinoblastoma, for example, is a lesion no one has discussed as yet. Precision coning might be of value in this kind of lesion. I am also impressed with the problem Dr. Smedal brought up concerning the apparent benefit that can be gained with supervoltage in re-treating an area already damaged from lower voltage.

Cooley: I am astounded at the amount of work that has gone on in the last two or three years. Most of the facts and opinions presented here would indicate that supervoltage is a definite addition to our armamentarium and should be used more extensively. Fact after fact, piled one on top of the other, might have become a little monotonous except for the presence of three people—there are others, too—but I should like to pay tribute to these three:

Dr. Friedman has frequently risen to the occasion. He has been most helpful to me. He has told us, when certain points are asked and details of supervoltage are under discussion, to be careful—that “This sort of thing can get you into trouble.”

He has indicated where certain aspects, physical aspects, of supervoltage are helpful and how they should be used. Frequently it apparently was different from the way I thought it would have been. I would characterize in one word his comments as “stimulating.”

Professor Smithers has shown us how things might be a little different, and a most helpful contribution has been his forecast, more or less, of the directions that work in supervoltage will take and what we might

expect. Also, he has indicated things that we should do. I would characterize his comments in one word as “wise.”

We have had Dr. Ellis’s comment frequently, and I would characterize his comments as “practical.”

I am most interested in increased patient comfort, the skin-sparing effects, and the decrease in radiation sickness. From this standpoint, I am convinced that the money spent is used wisely.

I was impressed with Dr. Smedal’s description of the treatment of carcinoma of the tonsil in continuity with the lymph node by a single rotational field. This is a sound basic approach. One wonders which method, that of Dr. Simon or that of Dr. Smedal, will prove better.

My original ideas about the type of case that could be treated by supervoltage must now be enlarged. I had no idea that skin tumors could be treated, or should be treated, with supervoltage in preference to lower voltage on some occasions.

I was also impressed by Dr. Smedal’s demonstration of the treatment of advanced carcinoma of the breast and treatment again with one field by using a scanning technique, in what seems to be a very sound approach to treatment of a widespread tumor. I should like to know more about this technique.

The problems of the radiation therapist have not been greatly changed by the advent of supervoltage. We still must avoid overirradiating the spinal cord. We must think about late skin changes, which have been so well demonstrated to us here. We must still remember the vulnerability of the bowel and the stomach. Radiation pneumonitis and fibrosis are still with us. Also, kidney damage is a problem not peculiar to supervoltage.

The concept of a lower biological efficiency, coupled with the high skin tolerance to supervoltage irradiation, presents an invitation to overdosage that may be difficult to resist.

I should like to restate another problem: At what stage in the course of treatment of four, five, or six

weeks' duration do we decide that a tumor is radio-resistant? Occasionally I have seen tumors that, at the end of the four or five weeks of treatment, appeared not to have regressed. At this crucial stage a decision must be made about whether further treatment with its increased risk must be carried out. Are we permitted to say at this time that this tumor is radioresistant? I have seen tumors with little or no regression at the end of five weeks; yet after another month there has been a brilliant local result. When can we say that a tumor is radioresistant?

Friedman: Dr. Cooley, on behalf of the "one-word designees," I want to thank you for your remarks and for the graciousness with which they were delivered.

Now I think it would be in order to have a hassle, and, before calling on the clinicians, I should like to get some reactions from the physicists.

Loevinger: I should like to say a few brief words about Dr. Tubiana's paper. First, my congratulations to him! He is the first in this symposium to use the word "rads" without feeling self-conscious about it.

Second, I must revise a previous statement of mine. When I said that, in the supervoltage region above 1 Mv, we would expect one rad to be like any other, I overlooked the possible difference between pulsed and steady beams. The pulsed beams from accelerators may show an RBE different from that of gamma beams, and the RBE might even be a function of pulse frequency.

Third, Dr. Tubiana said, quite rightly, that the betatron is not suitable for superficial tumors or for situations where it is necessary to protect underlying structures. He was speaking of the X-ray beam. Presumably his betatron will, in time, have available an electron beam. It may even be that he will be able to change from X rays to electrons by the mere throw of a switch. At that time the opposite of his statement will be true, i.e., these betatron electrons will be particularly suitable for treating superficial tumors and situations where underlying structures are to be protected.

Chalmers: I am interested to hear Dr. Smedal's method of treatment of the pituitary with 360-deg rotation using a 3-cm beam. I have just seen the Berkeley setup for treating with 380-Mev protons, and a great deal of trouble has been taken to limit the beam to 60-deg rotation, as well as to rotate the patient in another direction.

Efforts will be made to reproduce this proton therapy in Chicago, Ill., Uppsala, Sweden, and possibly Liverpool, England. Therefore I should be glad to hear whether Dr. Smedal considers it necessary that this beam be limited to these fine-angle cones.

I have had no experience with betatron therapy, but I was fascinated by Dr. Tubiana's work on heterogeneous phantoms. The only query I have is concerning the lung-tissue density, which he said was 0.5; we thought it was 0.3.

He also gave us a mean energy for the 22-Mv betatron of 7 Mev. I have been chasing that figure

for some time. Perhaps he would tell us how he obtained it.

Rubinfeld: May I make a comment about Dr. Simon's dosimetry patterns in his outlined treatment for carcinoma of the thyroid? Paradoxically, he chose as the best pattern the one that generally is considered the most undesirable, namely, the single port, because it contributed least to the spinal cord. This problem illustrates the need for constant attention to anatomical concepts in changing from conventional to supervoltage and teletherapy irradiation.

The limitations that anatomy dictates were recently illustrated when we treated a carcinoma of the anterior floor of the mouth. The initial treatment plan included two opposing lateral portals and one submental portal; but, when the isodose curves were outlined, it was estimated that the eyes would have received 40 per cent of the central submental beam. A tumor lethal dose to the lesion would have delivered about 2500 r to the eyes, which in a 40-year-old man could be cataractogenic. With conventional therapy the dose to the eyes would be insignificant.

Thus, with high-energy irradiation, mid-line dosage calculations are not enough. Dosage should be studied for critical organs, in addition to the spine, to establish limitations of portals and dosages.

In this respect, the electronic rotational isodose computer of Dr. Chalmers may eventually be a most valuable aid.

Smithers: I believe I probably have the distinction of being one of the few people here who have had clinical experience with all three modalities discussed. I should like to say one brief word about each.

Concerning short-distance therapy, I think Dr. Simon's paper is extremely interesting and really underlines our long experience with teleradium, which I have mentioned once or twice before and which I think is important.

Dr. Tubiana mentioned one thing that I think Dr. Simon omitted—the extreme value of this quality in combining surgery with irradiation. A patient who has short-distance good-quality radiation for the treatment of carcinoma of the larynx, for instance, still stands a chance of cure with surgery should irradiation fail. Normal tissues must be spared to give the surgeon a chance, and it is here that the better quality radiation is so important.

With regard to 2 Mv, may I show you one technical trick? It is perhaps a slight improvement on the very good work Dr. Trump and his group and Dr. Smedal have done with their beam-shaping devices—and very useful they are indeed! The blocks, which take out parts of the beam, should be formed to the shape of the beam and should move on the surface of a sphere centered at the focal spot [Chap. 64, Figs. 33 and 34]. In high-voltage treatment around the eye, for example, these are particularly useful [Chap. 64, Fig. 35], as my colleague Dr. Lederman has shown.

Jacobs: Dr. Tubiana's paper brought to mind a series of 10 esophagus cases that I helped the late Dr.

Coutard treat in 1937 and 1938 at the California Institute of Technology. Dr. Coutard was an aggressive radiotherapist at that time, and he gave these patients tumor doses of the order of 6000 to 8000 r.

There were 10 cases within a period of one year, and all patients were dead within nine months. In nine of them there was no residual tumor, but in all 10 there were perforation of the esophagus and mediastinitis, which was the primary cause of death.

Ellis: Concerning the two right-angle fields Dr. Simon showed in connection with the thyroid demonstration, I could not help feeling that with wedge filters the distribution could have been very much improved. Wedge filters, I am sure, can be a great help with this kind of energy.

Dr. Smedal mentioned a scanning technique that has been evolved for breast cases. I wonder if he could give us a description of how it is done.

I am very much impressed by the fact that Dr. Tubiana investigated the condition of the heart after this type of irradiation. I feel that it is very useful and that more of us should carry out similar investigations. I have not come across any evidence before of definite changes in the heart after radiation.

Riemenschneider: Dr. Simon, in treating the parametria, are you increasing the distance, or are you using the same 30-cm distance?

Dr. Smedal, do you know whether the man with mycosis fungoides had had prior irradiation therapy for Marie-Strümpell arthritis and whether the entire vertebral column had been irradiated, thereby effectively irradiating a good bit of his bone marrow?

Meschon: I have been greatly concerned with large-volume treatment, i.e., the treatment of the primary tumor and the regional lymph-node area, such as in cancer of the head and neck and of the bladder. We keep talking about the treatment of deep-seated tumors and the failure in curing these cases with 2 Mv and supervoltage. I suggest that we shall always fail or practically always fail with those tumors that, by their inherent pathogenesis and early metastasis, are too advanced for cure.

We keep talking of the cure of carcinoma of the esophagus. The chief reason for failure is not necessarily perforation, but the propensity of this tumor for widespread metastasis above and below the diaphragm.

Similarly in carcinoma of the lung we are bucking the pathogenesis of that tumor. At the time of discovery, 75 per cent of these tumors are outside the chest. How can we hope to cure these tumors with external irradiation even with X rays in the high supervoltage range?

It may be different in head and neck tumors where the lesion is diagnosed earlier. Although there is a large percentage of lymph-node metastasis, supervoltage rotation may be of use. I should like to ask Dr. Smedal whether we should always, if irradiation is to be the primary mode of treatment, include in the irradiation field the primary tumor as well as the lymph-node area.

Collins: In the United States there is a parlor game called "Truth or Consequences." If we resort to the use of relative biological equivalents, we must also play this game.

The biological equivalents of measured amounts of radiation are sometimes thought to be different for different qualities of radiation. If we see a different biologic effect and we have used a different agent, this may be a reasonable or plausible conclusion.

However, I think it should be examined more closely. In the first place, do we think that this difference is quantitative or qualitative, or both? I am not aware of a qualitative difference in response to radiation of different wave lengths, although different wave lengths of light do produce a qualitatively different visual effect, interpreted as red, blue, or yellow. I am unaware that the kind of regression occurring in a radiosensitive tumor is any different for high-energy radiation from that for low-energy radiation.

In the end the effect of radiation upon a biologic process has to be a biochemical one at the molecular level. If we think of some molecular configuration vulnerable to the effect of ionization or excitation, what differences could occur? Different energies or different wave lengths could produce more change, but it is difficult to see how they could produce a different molecular change.

The biological difference in efficiency seems adequately explained on a quantitative basis. As long as we dealt with roentgens, there was a possibility that, because of energy dependence of our measuring device, the biochemical effect might be somewhat different from the effect on the ionization chamber. We could accept, perhaps, a quantitative difference in biologic effectiveness per measured roentgen by different forms of radiation.

I am disturbed to find that we are considering a biological difference in the effectiveness of a rad. The rad is the amount of energy absorbed, and, for a given amount of energy absorbed, how can we conceive that there is a difference in the biologic efficiency?

This is a matter of truth or consequences: One must either offer a suggestion or think of a better answer. I think there is a better answer at the clinical level. For a carcinoma of the tonsil treated at 200- to 250-kv levels, a conventional plan of treatment might be a five-field technique or a cluster on either side to deliver one's favorite dose in terms of a given number of roentgens. It seems to me impossible to deliver the same dose by a single-portal technique, or by two- or three-portal techniques, made possible by higher energy radiation. Although we may produce, roentgen for roentgen, a given damage to a given molecule in a given biochemical system in a given cell, a sharp epithelitis produced over the entire mucosa of the oral and buccal cavity is not to be compared with the more localized effect of simpler high-voltage techniques. The difference is not so much a matter of energy or the number of roentgens as the response of one

portion of the oral mucosa to changes that are going on in the whole oral mucosa.

As a rough parallel to explain what I mean, if we are dealing with thermal burns, it is one thing to be touched with a lighted cigarette, which perhaps raises a blister; to apply the same temperature to the entire hand or to a large area of the body certainly produces a biologically different effect. However, it is not a quality of the heat; it is rather a quality of the response of the whole organism.

I think biologic equivalence is not so much a factor of the different energies submitted, but alterations of the whole treatment plan as we undertake a new modality of radiation.

Simon: I must tell Dr. Loevinger, first, that we are all self-conscious about the rad. When Dr. Tubiana presented the situation and described his doses in rads, he also had corrected for something that all radiotherapists want to do. He has made transit dose studies and corrections for density of tissue.

Why should we not be self-conscious when saying, "This is a rad, rather than the old r we are used to," when actually the conversion is just a conversion of words? Our self-consciousness in talking about absorbed dose comes from variations of 2 to 1 in the density of tissues.

If our radiological physicists would provide data for model tissues with variations in density, it would help extremely in the plan of treatment.

I should like to comment on Dr. Riemenschneider's question about how we treat carcinoma of the cervix. After the patient is treated with intra-uterine and intra-vaginal radium, the dose to the parametrium is raised by Co⁶⁰ radiation. The field is shaped like an inverted U, the mid-line structures (bladder, cervix, and rectum) being shielded from radiation by a block of lead 4 cm wide and 5 cm thick. This block represents filtration of about four half-value layers in the mid-line to cut the exposure dose to the mid-line structures to less than 10 per cent of the parametrial radiation.

The eyes can be protected from radiation similarly. Blocks of lead equivalent to several half-value layers are supported on the eyes by fitted plaster molds. Such devices are particularly useful to shield the eye from the direct beam or the penumbra.

Smedal: In answer to Dr. Ellis's first question about retinoblastoma, Professor Ivor Williams from London discussed the treatment of retinoblastoma with radium at a meeting in Houston, Tex.*

Concerning the use of eye blocks, there is transmission of about 2 per cent and probably a scatter component of 300 r with a dose of 6000 to 7000 r. We estimated that the eye receives about 550 r. Dr. Hunt, I think, has the answer to the treatment of retinoblastomas.

Dr. Cooley asked about the setup of external beam shaping, which brings to mind Dr. Smithers's nice setups for the beam definition. We have not done as much as we should do about this. I think perhaps more information should be published, with suitable illustrations, about how to accomplish beam definition.

Dr. Chalmers mentioned pituitary rotation; it seems to me the problem is simplified by using 360-degree rotation. If you use less than that, you are scanning a sector, and you change the shape of the fields and the position of the axis. It is much easier by use of complete rotation.

Dr. Rubinfeld mentioned thyroid treatment with a single field. I do not know how inaccessible nodes will be treated; on thyroid dissection, nodes will be found up to the tip of the mastoid. We prefer to do it by rotation, treating both sides of the neck.

In answer to Dr. Riemenschneider's question about the patient who had both Marie-Strümpell arthritis and mycosis fungoides, he did have previous X-ray treatment for arthritis. Practically all our patients with mycosis fungoides are treated by X ray, nitrogen mustard, and any imaginable form of therapy before they come to us, and therefore their bone marrow has been heavily irradiated before we see them.

The breast-scanning technique, Dr. Ellis, is a combination of opposing portals for the supraclavicular neck and axilla, combined with scanning of the chest wall, done in one operation, with suitable moving blocks.

In answer to Dr. Meschan's question about probable areas of treatment, we still feel the same about treating diseases of the head and neck and include the areas of metastatic spread. If we treat carcinoma of the esophagus or lung, which we are doing less often than we did a couple of years ago, we treat large fields because the disease is so widespread. I am very pessimistic about controlling cancer in these cases.

Tubiana: I shall refer briefly to the different questions. First, I am sorry to have confused Dr. Loevinger. I was, of course, speaking only of photons and not of electrons. To Dr. Chalmers I shall say that in this range of energy the mean energy of a spectrum of photons is about one-third of the maximum energy. Everybody agrees on a mean energy of 7 Mev for a peak energy of 22 Mev.

About transmission through lungs, we also expected that the linear absorption coefficient would be 0.3 of what it is in water. In fact, the value of 0.5 agrees very well with our measurements, although neither is accurate enough to allow any general conclusion. It is possible that the blood content of the lung explains the difference between 0.3 and 0.5.

Dr. Ellis pointed out that it was surprising to find heart lesions, but they seem to exist. I do not know their significance.

A peak energy of 22 Mev is not enough for Dr. Riemenschneider's suggestion. At a depth of 2 cm

* Meeting of the American Radium Society in Houston, presentation by Ivor Williams on the use of radiocobalt disks in the treatment of retinoblastoma, with discussion by Dr. Hunt.

INDICATIONS AND CONTRAINDICATIONS

the maximum dose is nearly reached, and only the superficial tissues are spared.

My answer to Dr. Meschan is that at present we are combining radiation with surgery for the treatment of the base of the tongue. We irradiate the tumor, and a neck dissection is performed by the surgeon.

About RBE, I think, as Dr. Collins thinks, that differences in the volume of irradiated tissues and in dose distribution could explain variations in the effects of radiation. However, there are also actual

differences of biological efficiency. For a given absorbed dose in a given volume, the tissues do not respond the same at all energies. The differences seem to be due to differences of linear energy transfer along the tracks of ionizing particles. Between the primary event (which is physical) and the terminal biological effect, there is a long chain of events that are mostly chemical. It is not surprising that at least some of them are influenced by the spatial distribution of the chemical entities deriving from ionization and excitation.

Section

I

Special Techniques for Special Tumors

**John A. Isherwood
and
Vincent P. Collins
(presiding)**



The Esophagus

CHAPTER 42

Irvin F. Hummon

Cook County Hospital
Chicago, Illinois

Abstract

Carcinoma of the esophagus was treated with Co^{60} radistion through multiple fields. Tumor doses of 6000 to 7000 r were given over a period of six weeks. Individual cases are described. Average survival was about 18 months for those who survived two or more months.

Introduction

All of us think of carcinoma of the esophagus as the ideal tumor for rotational therapy. Some cases respond well; others do not respond. This is true of 250-kv irradiation as well as supervoltage therapy.

The first case we treated with our supervoltage equipment was a carcinoma of the esophagus.

Case Histories

Case 1. The patient was a 75-year-old man with a typical lesion of the esophagus (Fig. 1), in the middle third, almost completely obstructing the lumen. He had lost weight. Our surgical friends did not choose to operate, and so he was sent to us.

A cast of the patient was made, knitting needles being used to lay out the fields. Three fields, 8 by 15 cm each, were employed. One field was anterior, and two fields were posterior oblique to avoid the cord. In a patient with an anteroposterior diameter of 20 cm, a tumor dose of 7000 r was achieved with skin doses of 3500 r to each of three ports.

As with beginners' luck, this case turned out well. Figure 2 shows the lesion on completion of therapy. The treatment time was about six weeks.

Our philosophy in treating carcinoma of the esophagus has been to fractionate the treatments over a rather long period, hoping to minimize fistula and mediastinitis.

This patient remained well for approximately one year, when obstructive symptoms recurred—again a rather familiar story. At esophagoscopy the lumen was smooth, and there was no evidence of disease. The biopsy specimen had no carcinoma. We assumed

that symptoms were due to cicatricial contraction following irradiation. The esophagus was dilated at monthly intervals.

Two and one-half years after the initial treatment, the patient acquired pneumonia and died. At post-mortem examination there was no evidence of carcinoma.

Case 2. A woman, aged 75 years, had dysphagia; she lost 25 lb over a period of six months.

Figure 3 shows the lesion in the lower part of the middle third of the esophagus. Treatment was the same as with case 1, except that the tumor dose was 6000 r. After treatment, X-ray examination (Fig. 4) showed a smooth lumen with some defect, but it showed a patent, functioning tube. The reason for the smaller dose was that some patients with the higher dosages had developed pneumonitis. One patient had pericarditis with effusion, which we assumed was partially due to the irradiation.

Case 3. Figure 5 shows another typical lesion with almost complete obstruction in the lower third of the esophagus, almost involving the cardiac end of the stomach. This patient had a stoma in the stomach for feeding and was in fairly good health. Again we delivered a tumor dose of 6000 r. Figure 6 shows the effect achieved at the end of therapy, which was six months ago. He now feeds through the esophagus, the stoma no longer being used.

Survival

We have treated about 75 of these lesions in the last three years. Our longest survival has been about two and one-half years, with an average, of those who survived two or more months, of about 18 months.

Constriction Following Therapy

The problem of constriction of the esophagus after therapy has been attacked by one of our surgeons. He inserts a flared polyethylene tube into the esopha-



Fig. 1—Carcinoma of the middle third of the esophagus before therapy.



Fig. 2—Same patient as in Fig. 1 after therapy with a tumor dose of 7000 r.



Fig. 3—Carcinoma of the lower portion of the middle third of the esophagus before therapy.



Fig. 4—Same patient as in Fig. 3 after a tumor dose of 6000 r.



Fig. 5—Carcinoma of the lower third of the esophagus before therapy.

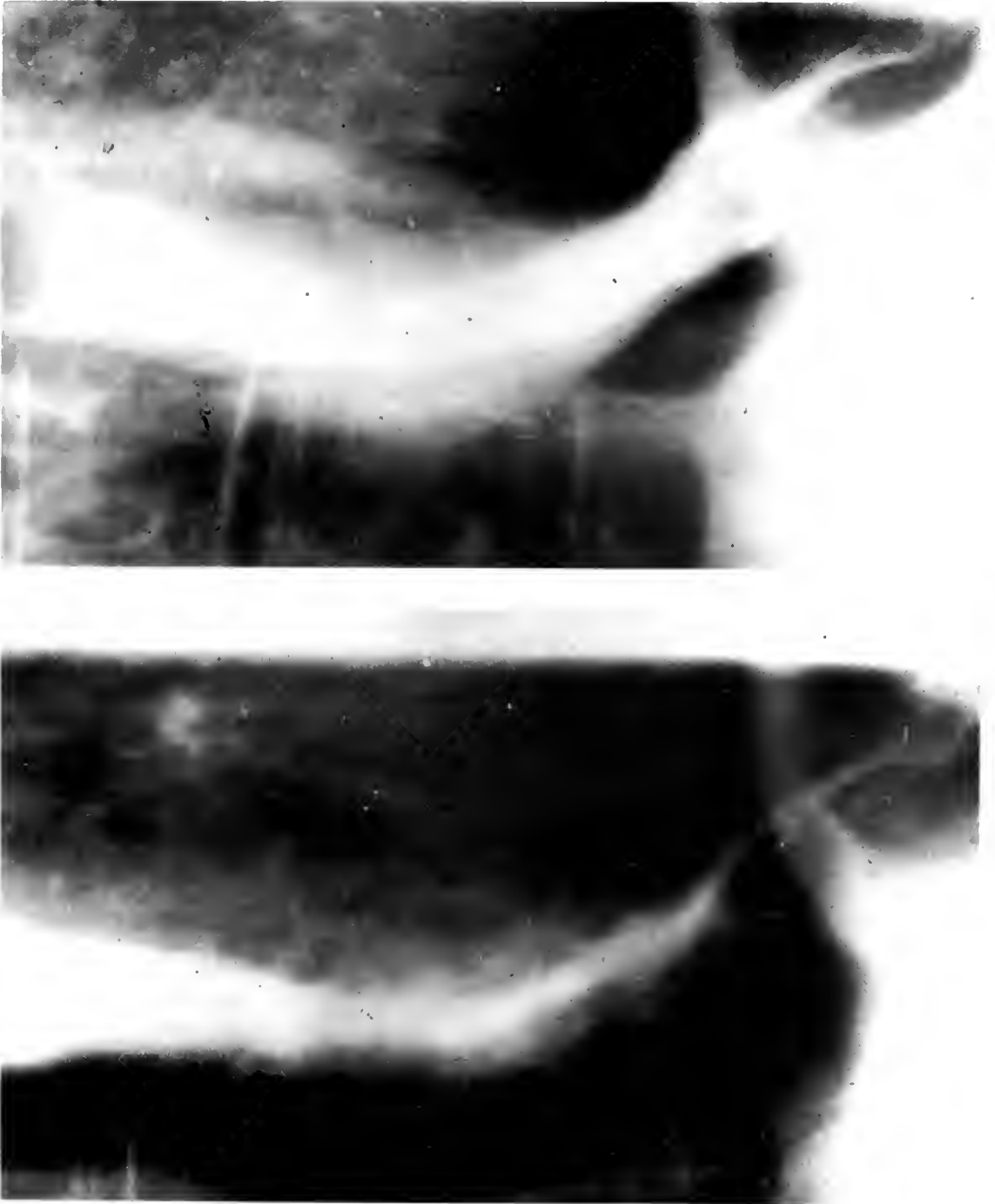

Fig. 6—Same patient as in Fig. 5 after a tumor dose of 6000 r.

gus, bringing it in contact with the lesion and placing a suture above the tube to hold it in place. With this a patent lumen is maintained whether radiation is given or not. We have irradiated a number of these intubated patients. In two patients the tube slipped into the stomach. To avoid this, a second suture is placed below the flange to fix the tube in place. So far I am not convinced of the long-term efficacy of intubation. If the lesion is controlled and the lumen remains narrow, it is preferable to dilate rather than to leave an irritating foreign body in a region of neoplasm.

Discussion

Tubiana: I wonder whether, like myself, many people found that a great number of patients with cancer of the esophagus died from lymph nodes under the diaphragm. If so, I wonder whether it would be useful to treat these nodes by some means or other.

Most of the time, in treating thoracic esophagus, one is concerned only with thoracic esophagus. We are beginning now to consider the use of either surgery or radiation to treat lymph nodes that are under the diaphragm or outside the thoracic region.

The Breast

CHAPTER 43

Robert N. Cooley

University of Texas
Medical Branch
Galveston, Texas

Abstract

The principles upon which radiation therapy of the breast should be based are enumerated. Several of the commonly used techniques are briefly described, along with what appears to be their shortcomings. Ten-year follow-up data indicate that, even if treatment of the local disease in the breast and adjacent lymph nodes is entirely successful, we would still fail to cure permanently in more than half the patients. The reasons for the author's preference for the so-called "McWhirter technique" are briefly given.

Surgery is a local treatment and is moderately effective in eradicating that part of the disease which is localized to the breast. Radiation therapy is a regional treatment, although it may be moderately effective in the same local area. However, when the treatment area is enlarged to include disease in the axillary, supraclavicular, and internal mammary lymph nodes, success with either surgery or irradiation or both is much less certain. The sobering fact is that 10-year follow-up data indicate that between 55 and 60 per cent of all patients die with disease disseminated beyond the breast and the regional lymph nodes. Therefore more than one-half the patients with carcinoma of the breast are not amenable to any form of curative therapy that we now know.

Figure 1 is an old cut of R. S. Handley's, which is reused by Halsted¹ in a later paper. On the left is the observed extent of the dissemination of cutaneous and subcutaneous metastases due to lymphatic spread. Handley was trying to correlate these extensions with the observed dissemination to the bony structures shown on the right. In over half the patients death will be due to disease that lies somewhere within this area and outside the local breast area.

The following fundamental principles must be adhered to if good irradiation therapy of the breast is to be obtained. Usually these principles can be applied without too much compromise.

1. A specified tissue volume should receive a relatively homogeneous tumor lethal dose. Unfortunately,

in carcinoma of the breast there is considerable variation in the tumor lethal dose, but for the purposes of this discussion I shall consider the tumor lethal dose to be somewhere between 3500 and 6000 rads delivered in four to five weeks. If the treatment is prolonged, as recommended by F. Baclesse, over a period of 8 to 12 weeks, higher dosage of the order of 6000 to 8000 rads should be considered. However, only in a minority of cases is it possible to administer a tumor lethal dose.

2. Irregular tumor extensions or local metastases should be included in the irradiated volume and should be treated at the same time in continuity with the primary tumor. If the primary tumor has been adequately dealt with by the surgeon, we do not attempt to irradiate the primary site. This means, in general, that most stage I tumors (Manchester classification) do not receive postoperative irradiation to the chest wall.

3. The volume of irradiated normal tissue should be minimal, and normal tissue tolerance should not be exceeded. We must give special consideration to the underlying lung (which is susceptible to pneumonitis and fibrosis) and to bone (such as ribs, clavicles, and the upper end of the humerus), and we must avoid skin necrosis. In advanced lesions in which local disease is extensive, we prefer to use the Baclesse type of treatment with prolonged irradiation over periods of 8 to 10 weeks.

4. Dosage should be standardized. This is axiomatic if we are going to evaluate the effects of irradiation on breast tumors. In a large and busy department it is helpful to have a technique that will permit approximation of dose without too many difficult calculations and manipulations.

The next consideration is the volume of tissue to be treated. Figure 2 diagrammatically shows the first line of defense, mainly the regional lymph nodes of the breast. These nodes extend downward to the zyphoid and beyond, and also to the axilla, supraclavicular, and subclavicular areas.

Table 1 shows that, where there were no axillary metastases, 9 per cent of 125 cases had internal-mammary-node metastasis in only the upper two or three intercostal spaces on the same side.² We know nothing about the lower nodes or the opposite chain of nodes. Another finding of great importance is that, in 48 per cent of 81 patients with axillary metastases, the internal mammary nodes were involved. O. H. Wangenstein and his colleagues, after performing a series of superradical operations, found that approximately 60 per cent of patients with axillary metastasis had either supraclavicular or internal-mammary metastases or both. Consequently the internal mammary nodes must be irradiated routinely.

Table 1—HANDLEY'S DATA ON METASTASIS TO INTERNAL MAMMARY LYMPH NODE IN CARCINOMA OF BREAST

Status of axillary nodes	No. of cases	No. of internal mammary metastases	Patients with internal mammary metastases, %
No metastases	44	4	9
Metastases	81	39	48
Total	125	43	34

Figure 3 is a more detailed view of the other lymph nodes that may be involved.³ There is a limit to the tissue volume that we can irradiate, from the point of view of integral dose, accessibility, and systemic tolerance of the patient to irradiation. The region we irradiate is indicated by the lines in Fig. 3.

Before commenting upon the McWhirter⁴ technique, I should like to mention, only to discard, a few alternate methods and to tell why I consider them less advantageous than our technique.

1. The high-voltage (250 kv) plus low-voltage (100 to 140 kv) arrangement: The axillary, supraclavicular, and sometimes the internal mammary areas are irradiated with 250 kv through multiple rectangular fields; the skin over the chest wall is treated with low-voltage radiation to two or three large direct fields. This technique is used almost entirely in postoperative cases. It is undesirable, however, to irradiate the chest wall to any substantial dosage with 100- to 140-kv X rays because of the risk of damage to the underlying lung. Also, with large fields at relatively short focal distances, the distribution of radiation to the chest wall is inequitable. It is possible that the low-voltage radiation might be advantageously replaced by the electron beam.

2. High-voltage multiple glancing fields as described by Paterson.⁵ Three or more large fields are arranged to cover the chest wall, supraclavicular, and axillary areas. It appears that overlap of fields is very likely; assessment of dosage and standardization of technique are difficult. Time-consuming effort must be spent to avoid complications due to overlapping or underdosage of skin area.

3. Two large opposing fields using high-voltage radiation: Allchin and Wilson⁶ of the Westminster

Hospital in London described an arrangement of two large fields using specially designed applicators that covered not only the chest wall but the supraclavicular and axillary areas as well. A third central field to the chest wall was used in large patients. Standardization and assessment of dosage was not too difficult. However, I am doubtful that the internal mammary areas are given enough irradiation by this technique. Also, the dosage to the lungs must be higher than necessary. There is an advantage in using two large opposing fields. The factor of overlap of two adjacent fields is eliminated, and the minor risk of skin necrosis is avoided. Also, where two adjacent fields fail to come into close contact, there is risk of cutaneous metastases or recurrence. Consequently it is of some theoretical advantage to use two large opposing fields.

4. Multiple direct adjacent irregular-shaped fields according to the technique of Baclesse: There is little attempt at standardization, and the assessment of dosage is relegated to a minor position. Irradiation with this technique is usually given over a considerable period of time and is modified by the general

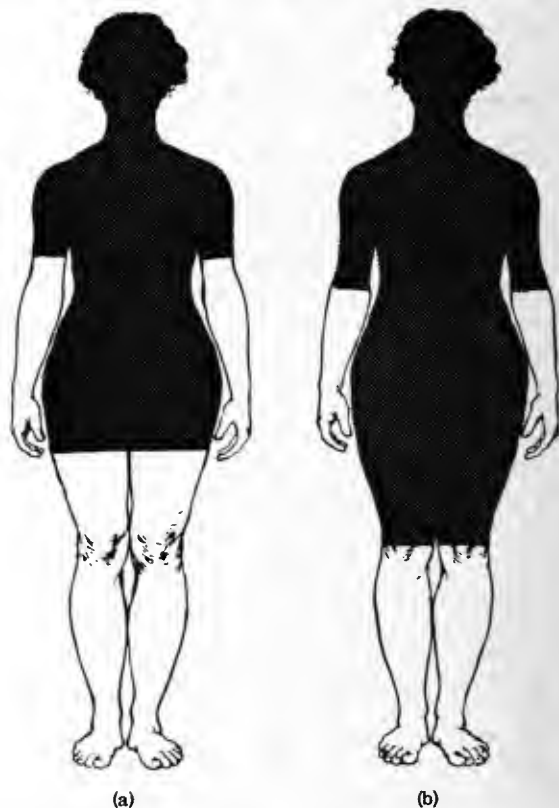

Fig. 1—Diagrams showing the maximal distribution of subcutaneous nodules and of metastases in bone from mammary carcinoma. The black area in a is the area liable to subcutaneous nodules; that in b is the area within which bone metastases occur. (Courtesy of J. B. Lippincott Co., Philadelphia, Pa.)

status of the patient and the condition of the skin. The use of this technique requires considerable experience and a device for precise reduplication of the fields.

5. Scanning techniques to the breast and regional lymph nodes: These techniques, developed by H. F. Hare and his colleagues, have been described by Dr. Smedal. They require special equipment and cannot be used in most therapy installations. They seem to be sound in their conception.

fields and is thus supplemented by 700 to 1000 rads of 120-kv X rays.

The posterior supraclavicular field has been criticized by some as being poorly placed. It is true that it does not tend to irradiate the axilla effectively and that it does not follow the chain of axillary lymph nodes

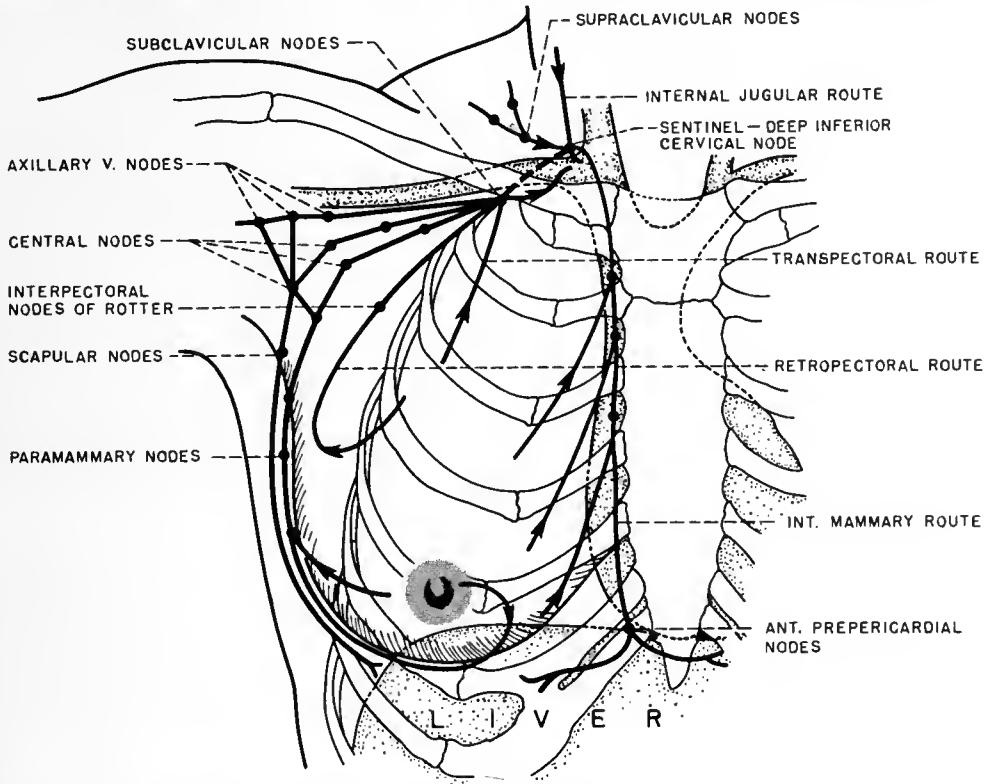

Fig. 2—Diagram of lymph nodes immediately adjacent to the breast. (From *Ann. Surg.*, 34: 523; courtesy of Drs. McDonald, Haagensen, and Stout and C. V. Mosby Co., St. Louis, Mo.)

6. Two sets of opposing fields using 250-kv X rays (McWhirter technique):⁴ An example of the McWhirter technique is shown in Fig. 4. The two glancing fields are 10 by 15 cm in size, and the medial field is placed 2 cm beyond the midsternal line. The lateral 10- by 15-cm field opposes the medial one and touches the skin near the midaxillary line. The area between is filled with bolus. This makes calculation of dosage across the area rather simple. The anterior supraclavicular field is 10 by 20 cm or 12 by 20 cm, depending upon the size of the patient. There is a directly opposing 10- by 15-cm posterior supraclavicular field with an intervening space filled with bolus. With this technique it is not too difficult to deliver a tissue dose of approximately 4000 rads in four weeks to the entire area. If the patient has had a previous radical mastectomy, the skin of the chest wall may not tolerate this dosage. Consequently smaller doses in most postoperative cases should be used.

If the two tangential fields are separated by an area greater than 22 cm, we add an extra field, about 5 cm wide, to the midportion of the chest wall. This is the area of lowest dosage between the tangential

with precision. This posterior field opposes the anterior field. The large posterior triangular field with the apex extending down the chest wall, as used by G. H. Fletcher of the M. D. Anderson Hospital, Houston, Tex., seems to be an ideal posterior field. However, special equipment is necessary to provide a field of this kind. The McWhirter technique is easily reproduced and makes assessment of dosage quite easy. It also enables one to refer to a set of tables which easily outlines a technique to deliver a desired dosage.

It has been suggested that the anterior and posterior axillary fields should be placed more obliquely downward. This would cause trouble with overlap of the tangential fields. If the chest wall is not irradiated, it may be practical to arrange both the anterior and posterior supraclavicular fields somewhat more obliquely, with the lateral portion lower and more nearly centered over the axilla.

The McWhirter technique seems to be among the best of the simpler techniques. It rarely requires extensive modification and has given demonstrated results in a large number of cases.

Discussion

Collins: I currently prefer to offer postoperative radiotherapy with our Van de Graaff at 2 million volts. I use two opposing tangential fields with a separation of approximately 22 cm. This is employed with bolus. A single anterior field covers the supraclavicular region and apex of the axilla. This three-field technique is somewhat simpler than the four-field technique that is necessary at 250 kv.

The other question is whether or not to treat the chest wall. The surgeon is often confident that he has eliminated the disease on the chest wall but has in mind a question of persistence in the supraclavicular region. Some say, "No, do not treat the chest wall,

After radical mastectomy with positive axillary nodes, we routinely treat the internal mammary, supraclavicular, and axillary regions. With 200-kv radiation, exposure doses of 3000 r in air are given in about five weeks. With cobalt teletherapy the exposure doses have been increased to 4000 r in air in the same length of time.

We do not treat the chest wall routinely because of the feeling at the Mt. Sinai Hospital that recurrences or persistences of disease in the chest wall are not sufficiently frequent to warrant it.

When axillary nodes are free of disease at the time of radical mastectomy, we treat with radiotherapy postoperatively if the resected carcinoma was subareolar or in the medial quadrants of the breast.

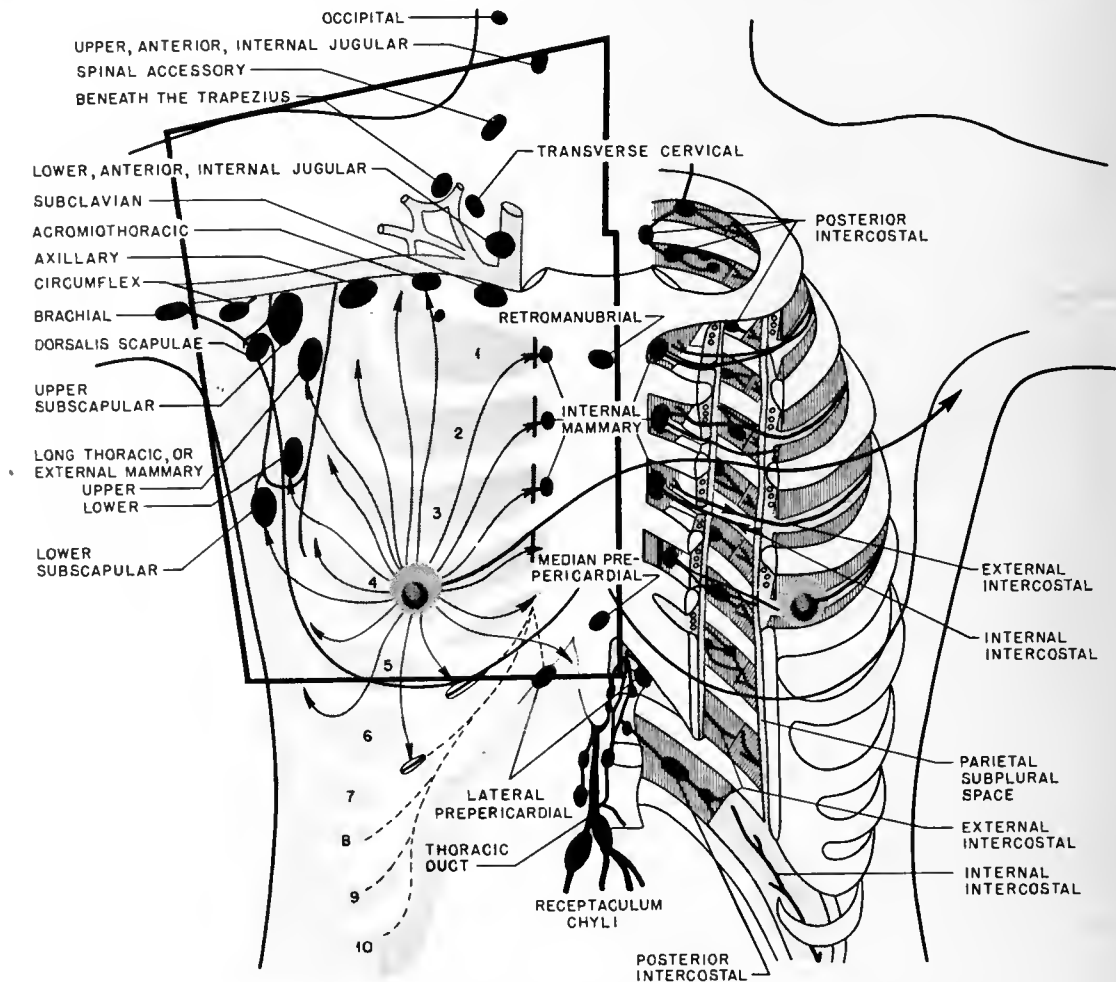

Fig. 3—Regional lymph nodes of the breast. (Modified from "Treatment of Cancer and Allied Diseases," G. T. Pack and E. M. Livingston (Eds.); courtesy of Paul B. Hoeber, Inc., New York.)

just the supraclavicular region," and others would prefer the whole to be treated.

Simon: Since we are not so certain of the beneficial results of our postoperative treatment for carcinoma of the breast, we are not very aggressive in our treatment.

If the tumor was lateral in the breast and the axillary nodes were negative, we do not usually treat.

Smithers: I think I have some rather peculiar ideas about treatment of carcinoma of the breast.

I regard postoperative irradiation as a confession of failure; that is, I think that the surgeon has failed

to do the job he set out to do. I think that a percentage of failure here is to be expected, and therefore a small proportion of postoperative irradiation is quite justified. But the department that is doing a good job and assessing the patients properly should have a diminishing amount of postoperative irradiation to do.

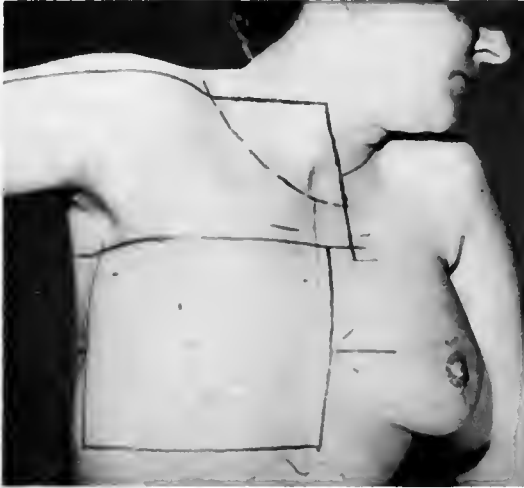

Fig. 4—Location of fields in the McWhirter technique. (From *Am. J. Roentgenol. Radium Therapy*, 62: 339; courtesy of Dr. Robert McWhirter and Charles C Thomas, Publisher, Springfield, Ill.)

This view is still regarded by many as a heresy. For locally advanced cases I prefer preoperative irradiation or radiotherapy alone.

As far as technique is concerned, the only point I would make is about the question of large supraclavicular fields. A supraclavicular field, I think, must include the curve of the chest wall and the axilla in order to include the lymph nodes that run along up to the head of the subclavius. Concerning the opposing field on the back, if it is a big field of the same size as the front one, a large portion is completely wasted. A large part of this field is merely going through lung and scapula. I am not greatly concerned about an opposing field for the supraclavicular fossa because most of the nodes of interest lie fairly anteriorly. The part of the anterior field which needs to be opposed is the outer part directed at the apex of the axilla.

Collins: Postoperative radiotherapy for breast cancer may be given in the hope of improving the chance for cure, but it is given with the intention of decreasing the incidence of local recurrence. One indication for postoperative radiation lies in the incidence of local recurrence. In the combined results of four reported series totaling 1544 radical mastectomies, the incidence of recurrence on the chest wall was 25 per cent. It was only 5 per cent if axillary nodes were negative but rose to 30 per cent if axillary nodes were positive for metastases. This means that one-third of the patients with axillary metastases may be expected to have recurrence on the chest wall. Even this in-

formation is incomplete since the duration of observation is not given.

In the files of the radiotherapy department of the Presbyterian Hospital in New York, there were records of 425 patients who were operable when first seen, were treated by radical mastectomy, were uncured, and were followed until the time of death. Of these patients treated by radical mastectomy but dying of breast cancer, 60 per cent (255 of 425) had no disease in the operative site (chest wall and axilla) at the time of death. For these patients treatment proved effective where it was applied, which is all that could be demanded of it. However, for 40 per cent (170 of 425), there was recurrence on the chest wall or in the axilla. For this group, treatment proved technically inadequate. The incidence of local recurrence is an indication of the need for some additional measure. This is the primary purpose of postoperative radiotherapy.

Ellis: I do not routinely treat the chest wall, but, if the primary tumor is near the skin and is about 3 to 4 cm in diameter, I do treat the chest wall; in such a case the risk of the surgeon's leaving something behind is greater than it is if the tumor is small and deep.

I also use the histological grade to some extent. I am more likely to treat the chest wall if the tumor is a Scarff's⁷ grade II or III than if it is a Scarff's grade I. Often it is necessary to treat the chest wall, even if the surgeon has performed a very extensive operation. In some of our worst cases, the patients were considered sufficiently operated on and were not sent along for treatment; later they had recurrences in the chest wall. At that stage they are extremely difficult to deal with.

I always treat the internal mammary chain whether the tumors are in the outer half of the breast or the inner half. If it has been a stage I, i.e., no axillary lymph nodes found, I always treat the internal mammary chain. I do not, in stage I, treat the axilla or the supraclavicular region.

I do not treat the supraclavicular region when no involved axillary nodes are found. Some Scandinavian authors found that, when the supraclavicular region was dissected,⁸ the supraclavicular nodes were never found to be involved unless the axillary lymph nodes were involved. However, if the axillary lymph nodes were involved, the supraclavicular nodes were involved microscopically in 30 per cent of the cases, even when there was no macroscopic invasion.

A clinical stage I needs a little care. McWhirter⁹ considers that, if no axillary lymph nodes are palpable, a radical operation would be useless. Handley, however, showed that the lymph nodes he dissected out from the internal mammary region were very often only the size of a pinhead.

It seems possible for lymph nodes in the axilla to be of the same size. Actually, I have proof of this because I once tried a drill biopsy on something in the axilla. I missed what I aimed for, but I got a report from the pathologist, on the material I sent, saying

that there was a complete lymph node involved by carcinoma. That node had come through a needle with an internal bore of only 1 mm. This accidental finding proves that there can be very tiny glands that no one can feel clinically. At such a stage a radical mastectomy for an outer quadrant tumor might possibly be definitely curative.

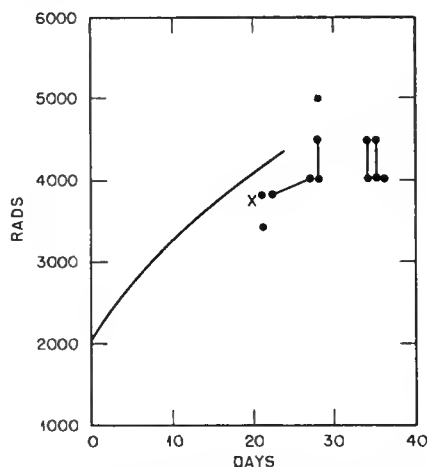

Fig. 5—Tumor doses used by the following radiotherapists in routine postoperative irradiation for carcinoma of the breast. The curvilinear regression line represents Dr. Friedman's isoeffect dose for recurrent chest-wall nodules. The \times is McWhirter's dose. Two points connected by a straight line represent a range of dosage.

	Rads	Days
Simon	4000	35
McWhirter	3750	20
Friedman	5000	28
Smithers	4000 to 4500	28
Collins	3400	21
Ellis	3800	21
Freid	4000 to 4500	35
Tubiana	4000	28
Lalanne	4000 to 4500	35
Lofstrom	3800 to 4000	21 to 28

On the other hand, we must assume that the smaller a tumor the more likely it is to be amenable to radiation, because probably there is less necrosis in it and therefore all the cells are likely to be more sensitive. Thus it might be that the irradiation of such tiny lymph nodes would be quite adequate.

For dose to be given, I think that, no matter how long it takes, the dose must be close to the normal tissue tolerance. Cohen^{10,11} has done some work on this.

The figure for skin is about 0.33, which I think is Strandqvist's figure.¹² It is also Cohen's figure, and he gives exactly the same figure for carcinoma of the breast. This means that the dose given must reach normal tissue tolerance.

Friedman: I should like to elicit from members of the audience their opinions as to the optimum dose of irradiation that should be administered to breast cancer. While allowing a moment to consider it, I shall

draw a scatter diagram on which will be placed the various opinions as to dosage [Fig. 5].

In a recent experiment to establish an isoeffect curve for breast cancer, some useful information concerning its lethal tumor dose was obtained. The experiment was set up to study recurrent chest-wall nodules in patients who had multiple lesions that could be given various doses in various over-all times.

The isoeffect curve ranged from 2200 r in a single exposure to 4000 r in 21 days. Although the points on the scatter diagram were derived with greater care than those of many published curves of a similar nature, the probable error was too great to warrant a mathematic designation for the slope of the isoeffect curve of tumor dose for carcinoma of the breast. Similarly, figures by Cohen for breast cancer and Strandqvist for skin cancer must be critically reviewed. Some of the published isoeffect curves are useful as a crude guide in clinical radiotherapy but are not statistically significant, with the exception of those of Edith Quimby and W. S. MacComb and those of A. Reisner for skin erythema.

After obtaining this information, we selected McWhirter's point of 3750 r in 20 days and drew a line through it parallel to our isoeffect curve.

With doses greater than those indicated by our average dose-line, there was 10 per cent failure (to eradicate skin nodules in about six months). In the dosage zone lying between our curves and McWhirter's doses, there was 25 per cent failure, and below the McWhirter dose-line there was 70 per cent failure.

Obviously the same dose cannot be assigned to small recurrent nodules as can be assigned to primary cancer of the breast, but it is not too unreasonable to assume that a small nodule would be more radiosensitive (or at least equally sensitive) than a larger primary breast tumor.

In the light of these data, I should like to get an expression of opinion from members of the audience about what prophylactic dose they would give postoperatively to the internal mammary and supraclavicular nodes of a patient who has been operated on for a stage II carcinoma with axillary nodes.

Dr. Smithers?

Smithers: I hate being pinned down to doses of any kind.

Friedman: Well, you are pinned down because here is your patient and you must treat her.

Smithers: Yes, but when I have a patient I look at the report; I see what kind the tumor was; I look at the patient and see what age she is; and I add a great many things together and start treatment. As I go along quite nicely, I see how she is taking it, and in the long run the dose she gets depends on a summary of all these things in my mind as time goes along; I do not prescribe a dose to give before I start at all.

Friedman: May I describe Mrs. Jennifer to you?

Smithers: Oh, dear!

Friedman: She is 52 years . . .

Smithers: Must this be done?

Friedman: Yes, because it is important. If we can possibly elicit an opinion from the audience, it could be extremely useful to all of us.

Mrs. Jennifer is 52 years old. She is in excellent physical condition. The histology was adenocarcinoma, grade II, that is, the primary tumor was moderately undifferentiated adenocarcinoma, with a few areas of very low grade adenocarcinoma, and one tiny nest of cells of undifferentiated carcinoma—the rather average breast carcinoma, with a mixed histologic degree of malignancy.

She had no radiation sickness; as a matter of fact, she flourished under irradiation, and her skin was able to tolerate radiation very well.

What tumor dose would you give her?

Smithers: She would probably get between 4000 and 4500 rads in four weeks to the supraclavicular nodes; she would not get so much to the parasternal node because she would not require it, as a rule. Here she would get 3000 rads.

Friedman: Mr. Chairman?

Collins: The Chairman will give an opinion: 3400 rads in 21 days.

Ellis: Thirty-eight hundred rads in 21 days.

Freid: Four thousand to 4500 rads in five weeks.

Meschan: . Are these doses from conventional voltages?

Freid: This is supervoltage radiation.

Tubiana: I suggest a dose of about 4000 rads in four weeks.

Lalanne: Between 4000 and 4500 rads in five weeks.

Lafstrom: Thirty-eight hundred rads in 21 days to 4000 rads in 28 days.

Friedman: We are getting some very valuable information. We have obtained a curve of an expression of opinion [Fig. 5], and I think we have achieved something that might be useful to us.

References

1. W. S. Halated, The Results of Radical Operations for the Cure of Carcinoma of the Breast, *Ann. Surg.*, 46: 11 (1907).
2. J. J. McDonald, C. D. Haagenen, and A. P. Stout, Metastasis from Mammary Carcinoma to the Supraclavicular and Internal Mammary Lymph Nodes (based on personal communication from R. S. Handley), *Surgery*, 34: 521-542 (1953).
3. G. L. Cheatele, Radical Mastectomy for Carcinoma of the Breast, pp. 776-787, in "Treatment of Cancer and Allied Diseases," edited by G. T. Pack and E. M. Livingston, Paul B. Hoeber, Inc., New York, 1940.
4. Robert McWhirter, Cancer of the Breast, *Am. J. Roentgenol. Radium Therapy*, 62: 335-340 (1949).
5. R. Paterson, The Treatment of Malignant Disease by Radium and X-rays, pp. 308-336, Edward Arnold & Co., London, 1948, and Williams and Wilkins Co., Baltimore, Md.
6. F. M. Allchin and C. W. Wilson, The Irradiation Treatment of Carcinoma of the Breast, *Brit. J. Radiol.*, 21: 406-413 (1948).
7. D. H. Patey and R. W. Scarff, Position of Histology in Prognosis of Carcinoma of the Breast, *Lancet*, 1: 801-804 (1928).
8. R. S. Handley and A. C. Thackray, The Internal Mammary Lymph Chain in Carcinoma of the Breast: Study of 50 Cases, *Lancet*, 257: 276-278 (1949).
9. G. Gordon-Taylor, R. McWhirter, and S. Cade, Discussions: Treatment of Cancer of the Breast, *Proc. Roy. Soc. Med.*, 41: 118-132 (1948).
10. L. Cohen, Clinical Radiation Dosage, *Brit. J. Radiol.*, 22: 160-163 (1949).
11. L. Cohen, Clinical Radiation Dosage. II. Inter-relation of Time, Area and Therapeutic Ratio, *Brit. J. Radiol.*, 22: 706-713 (1949).
12. M. T. P. Strandqvist, Studien über die Kumulative Wirkung der Röntgenstrahlen bei Fraktionierung; Erfahrungen aus dem Radiumhemmet an 280 Haut- und Lippenkarzinomen, *Acta Radiol. Suppl.*, 55: 1-300 (1944).

The Cervix

CHAPTER 44

I. Meschan

Bowman Gray School of Medicine
Winston-Salem, North Carolina

Introduction

The treatment of carcinoma of the uterine cervix has long been the combined use of intracavitary gamma radiation with external X-ray irradiation. There have been cyclic revivals of surgical treatment. There is occasional use of transvaginal X-ray irradiation. There is experimental use of parametrial injection of radioactive gold, and there is complete treatment by stationary or rotational supervoltage techniques. Through careful analysis of results over many years,¹ an optimum dosage pattern has been obtained.

The intra-uterine gamma-ray sources were usually radium capsules arranged in a flexible tandem, and the paracervical sources were boxes, capsules, ovoids, or spring devices. Despite efforts to standardize such techniques, the extreme mobility of the tandem and paracervical devices made physical evaluation of these treatment methods inaccurate, time-consuming, and difficult. The use of packing to maintain the position of the paracervical sources often meant that these would be found to be dislodged from their original position.

Attempts to assess tissue dosage by physicists were cumbersome. They often required three-dimensional reconstructions, and they were not readily applicable in a day-to-day operation where physicists were not available. Moreover, to achieve optimum placement of radium sources, the physician often exposed himself (particularly his hands) inordinately. In the earlier Manchester, Paris, and Stockholm techniques, the T-shaped arrangement has no rigidity between the paracervical sources and the uterine tandem. The calculations and conversions to gamma roentgens for a given application were time-consuming and impractical. Although it should ultimately be our aim to specify dosage in terms of energy absorbed in the tissues (rads), the most expedient intermediate step is the expression in terms of gamma roentgens delivered.

Many persons have designed rigid applicators.²⁻⁶ With the Campbell² and Ernst³ expanding colpostats,

there is a tendency to overdosage of the vaginal wall, especially in the lateral fornices. The spreading mechanism in the Ernst applicator frequently jams. The rigid applicator of the Fletcher design^{5,6} does not afford a rigid relation between the ovoids and the tandem. The contribution of the tandem to the bladder in this method is not readily calculated.

Principles of Intracavitary Treatment

It is apparent that certain principles must be established and treatment be correlated with these principles:

1. A mechanical gamma-ray applicator must be used that embodies the following factors:
 - a. It must be rigid.
 - b. It must be fixed with relation to the cervix.
 - c. It must allow a choice of tandem lengths and disposition of the paracervical applicator.
 - d. It must permit selective loading to achieve the most desirable dosage pattern.
 - e. It should keep its mechanical accuracy. The relative positions of sources must not change.
 - f. It should be physically constructed so that its reconstruction (outside the pelvis) in three dimensions is constant and predictable.
 - g. It should be simple to apply and to clean.
 - h. It must not be bulky.
 - i. Excessive exposure to the operator must be avoidable.
2. We must identify a limited number of points for dose evaluation. We are not treating only those points, but rather these are indexes of tissue dose.
3. On pelvic roentgenograms vulnerable areas (bladder and rectum) must be delineated since their proximity to the applicator will often determine the extent of therapy (Fig. 1).
4. Desirable dosages to be delivered to the index points and the effect of these on the vulnerable

areas should be ascertained with ease, preferably from tables by ready reference.

New Applicator Design

We have designed a specially constructed rigid applicator⁷⁻⁹ that makes use of all the advantages of the Manchester system but which still has a fixed tandem in relation to the colpostat sources. A method of fixation to the cervix is provided. The tandem and colpostats are each inserted separately and reassembled after insertion (Figs. 2a to 2c).

The tandem sources consist of 1-cm capsules joined in series, with a notch (which will appear on the radiograph) at the center of the source. Three different tandems are employed, depending on the length of the uterus. The short tandem consists of three capsules; the medium tandem, four capsules; and the long tandem, five capsules.

The colpostat sources are shown in the longitudinal section in Fig. 3. These consist of a Co⁶⁰ slug 1 cm in length and 0.32 cm ($\frac{1}{8}$ in.) in diameter, centrally spaced in a capsule 2 cm in diameter. The spacer is made of wood, and the capsular wall is 2 mm of brass. Disks of lead 5 mm thick, superiorly and inferiorly, help to shield the bladder and rectum.

Calibrated spacers are applied externally, and thus a known separation of the colpostat capsules is obtained. From the physical calculations it is found that usually the 6- or 7-cm spread of the colpostats gives the most satisfactory distribution of dosage to the pelvis.

Indexes Used and Optimum Dosage

We have defined certain anatomical fixed points (within the pelvis) that will serve as a basis for our calculations. It is not meant that designated points or summated gamma and X-ray roentgens have any great significance. These tabulations are indexes only, to assist in clinical management.

We have felt that more attention should be directed to the lateral wall of the pelvis, the bladder, and the rectum, areas to which spread may occur.

The points in the pelvis (Figs. 1 and 5) which we use are as follows:

1. Point C: 0.7 cm lateral to the center of the external os of the cervix.
2. Point C₁: 0.7 cm superior to the center of the external os of the cervix.
3. Point A: Tod's¹ point A, which is 2.0 cm superior to the level of the lateral fornix (upper margin of colpostat sources) and 2 cm lateral to the central uterine axis. (Tod stated that she considered the cervix to be eroded and that the external os was usually at the point of crossing of the uterine artery and ureter. Although this is not usually so, point A, in many years of application, has been proved to be a valuable index point.)
4. Point W: At the lateral wall of the pelvis, where the obturator lymph node is usually found. This is arbitrarily taken as 6 cm lateral to the central uterine axis and 2 cm up from the level of the lateral fornix. (This point is therefore 1 cm lateral to Tod's point B, which we have not found

to be a satisfactory index of irradiation to the lateral pelvic wall.)

5. Point BL: This point, on the posterior wall of the base of the urinary bladder, is obtained as follows: 5 cm³ of sodium iodide is placed in the Foley bag of the indwelling catheter, and the bag is pulled down upon the bladder trigone. On a lateral film of the pelvis (corrected for magnification), a point is designated which is 5 mm from the nearest posterior margin of the bag to the intracavitary applicator (Fig. 1a). This would indicate the serosal surface of the bladder near its base. Admittedly, this does not necessarily indicate the dose to the urinary bladder since the bladder wraps itself in variable fashion around the uterus.

6. Point R: The point on the rectum or sigmoid which is nearest to the intracavitary applicator. The rectum and the sigmoid are coated with moderately thick barium sulfate (not distended), and, on the lateral radiograph of the pelvis, this point is found. Care is exercised to make sure that this is a mid-line point as seen on the anteroposterior view of the pelvis and that it does not represent a loop of redundant sigmoid situated laterally. Occasionally, when an enterocele is present, the nearest intestinal loop other than the rectum is taken.

On the basis of experience with several hundred cases and in the light of microscopic studies of the pelvic tissues in a group of 26 surgical cases,¹⁰ we have selected certain dosage levels that we endeavor to obtain. These are given in Table 1.

Table 1—DOSAGE LEVELS AT DESIGNATED POINTS*

Pelvic point	Gamma, r†	X ray, r	Telecobalt, r
C and C ₁	7000 to 14,000	2000	3000
A	7000	2000	3000
W	1500 to 2000	3500 to 4000	4000
BL (maximum)	4000	2000	3000
R (maximum)	4000	2000	3000
Skin tolerance		3300	5000

* Ports, 8 by 15 cm; 220 kv; HVL, 1.5 mm of copper.

† The gamma radiation is given in one or two fractions in a total of four to seven days in continuity with fractionated X-ray therapy in an average of five weeks.

Method of Treatment

All patients are carefully examined in collaboration with the Department of Gynecology, and staging and method of treatment are decided upon jointly.

Stage I Without Parametrial Inflammation: immediate intracavitary irradiation is planned to give the total dose in four to seven days in one or two applications. If two applications are used, they may be separated by an interval of 7 to 14 days. External radiation is administered over five continuous weeks, making a total of six weeks for the two modalities. The physical factors used and the method of therapy are the same as those described for stage II. When the patient's measurements exceed 20 cm anteroposteriorly, there is some advantage in using supervoltage therapy.

It may be argued that external irradiation is unnecessary since the local disease is cured by the intracavitary gamma-ray medium and there is supposedly no tumor outside the confines of the cervix. Unfortunately, it has been repeatedly demonstrated by Taussig,¹¹ Morton,¹² Henriksen,¹³ and others that our clinical evaluation and staging by League of Nations' standards is about 25 per cent erroneous. Our own experi-

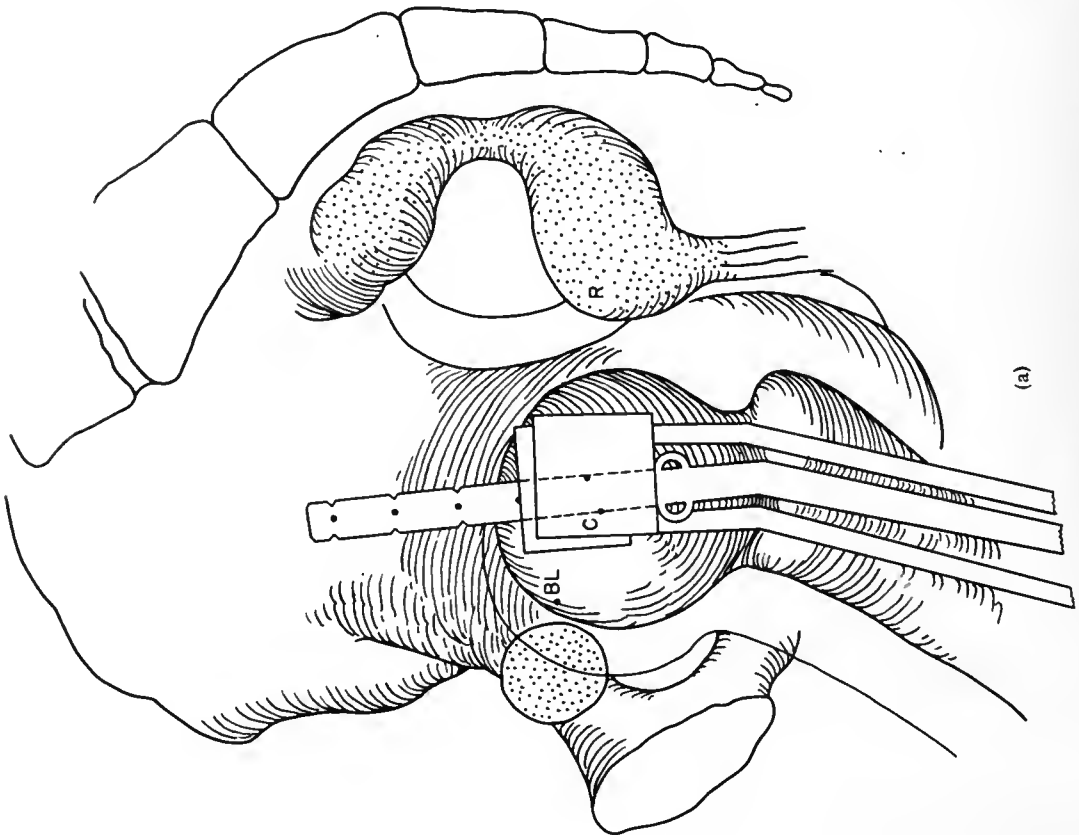

(a)

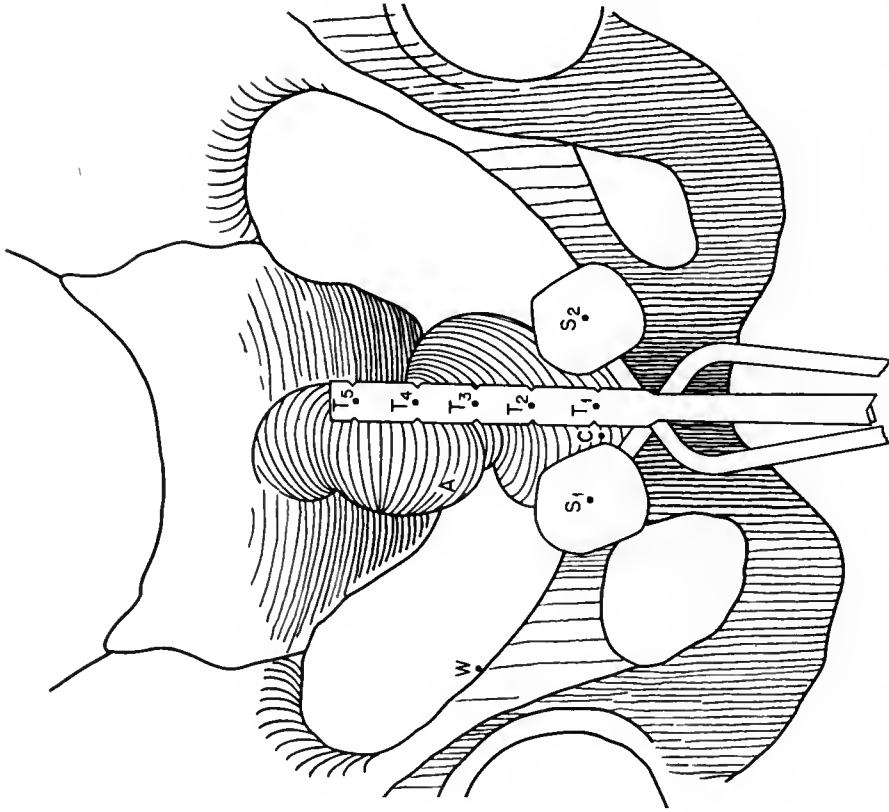

(b)

Fig. 1—Line tracings of the lateral (a) and anteroposterior (b) views of the pelvis, showing the cer-vical applicator in position and its relation to the various points of interest in the pelvis. The Foley bag catheter in the urinary bladder contains 10 per cent sodium iodide, and the rectum has been streaked with barium.



Fig. 2a—Photograph of the rigid applicator of our newest design, disassembled, showing how the tandem and the two colpostats can be inserted separately. The spacers are shown adjoining the applicator. These are set for $a = 1.75, 2.0,$ or 2.5 cm ($a = 3$ is not recommended).

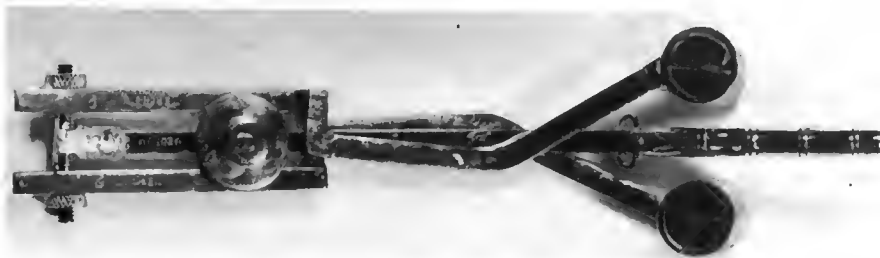

Fig. 2b—Photograph of rigid applicator assembled in frontal projection.

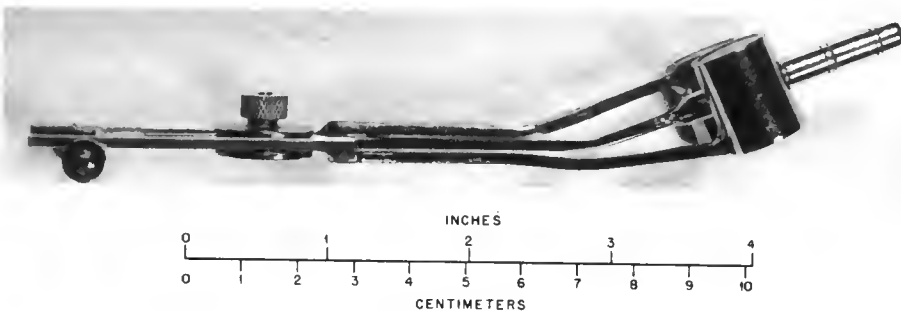

Fig. 2c—Photograph of rigid applicator assembled in lateral projection.

ence with a smaller series is in agreement, and we are not quite willing to deny our stage I patients the benefit of treatment to the entire pelvis.

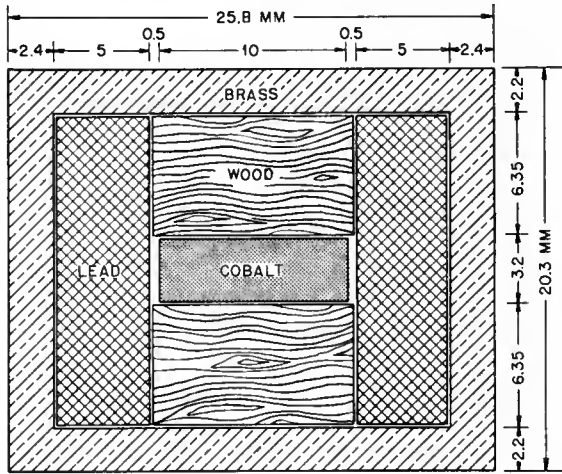

Fig. 3—Diagram of a longitudinal section through one of the presently used colpostat sources.

The physical factors for the roentgen therapy are 220 kv; 15 ma; 50-cm skin-to-target distance; and half-value layer (HVL), 1.5 mm of copper. A 4-cm-wide lead strip is placed down the middle of the pelvis (6 cm wide with telecobalt), both anteriorly and posteriorly, so that no direct radiation is applied to the tissues 2 cm (or 3 cm with telecobalt) from the mid-line on either side. This seems to help in the protection of the bladder and rectum.

Two anterior and two posterior fields are always used (Fig. 4). We add 10- by 10-cm gluteal ports when extra dosage is still necessary to the lateral pelvis. Usually two fields are treated daily, each receiving 300 r on the skin. On the first round, smaller dose levels are employed. After 7 to 14 days of such treatment, intracavitary gamma-ray therapy is given in one or two fractions over a period of five to seven days. If more than one intracavitary application is given, X-ray therapy is continued between applications. When a total of 3500 or 4000 r (X ray) tissue dose is delivered to the lateral pelvis, usually about 2000 r has been delivered to the cervix, rectum, and bladder (Fig. 4), although the lead protection strip is applied and the center of the cross fire has been the lateral pelvic wall.

Stage III with No Vaginal Extension Below Upper Third of Vagina: If the vagina is small and it is anticipated that there will be difficulty in the intravaginal application of the gamma-ray medium, a regimen similar to that for stage II

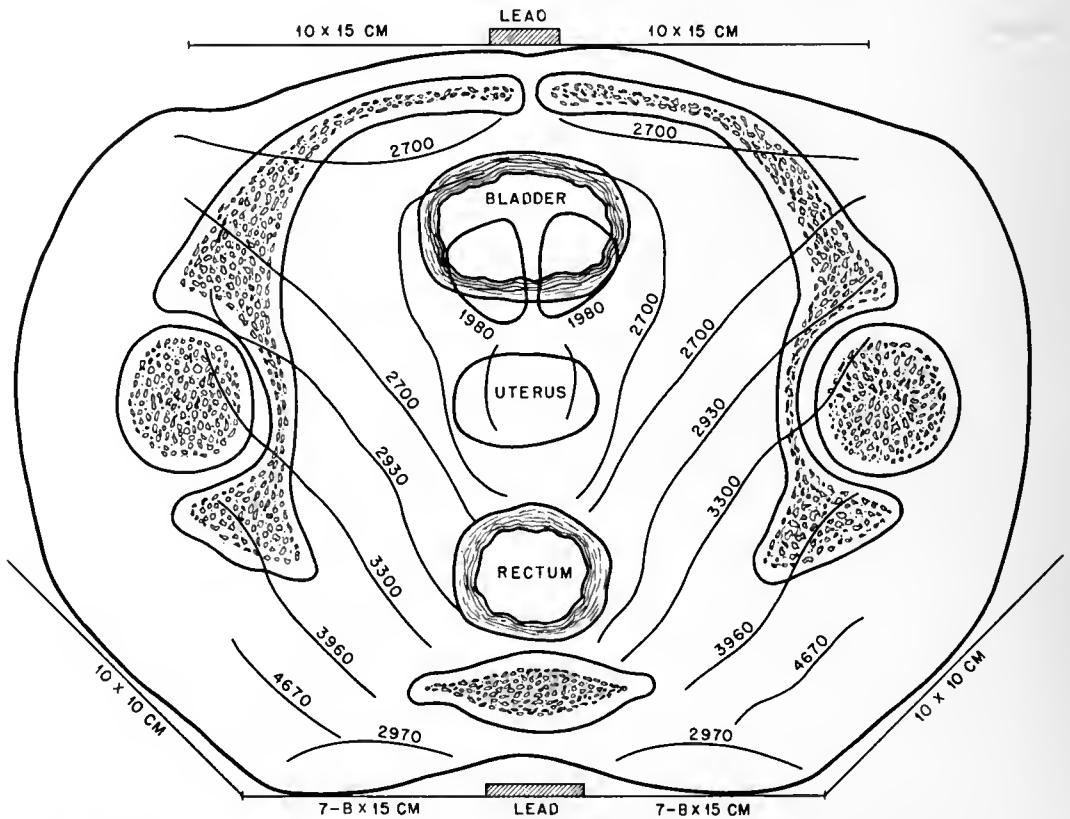

Fig. 4—Isodose levels in roentgens (six fields; 220 kv; 5 ma; Thor I added filtrations; HVL, 1.35 mm of copper; 50 cm TSD; 25 r/min/amp).

Stage I with Parametrial Inflammation and Stage II: Treatment is begun in these cases with external X-ray irradiation to six or eight pelvic ports, cross firing at the lateral pelvic wall (point W) on each side (not at the cervix).

patients is followed. If no difficulty in application of the gamma-ray medium is anticipated, all the external radiation is given first in these patients, and the intracavitary radiation is then applied in one or two almost continuous ses-

slons. It is hoped that with this plan there will be a maximum shrinkage of the tumor-bearing area before application of the gamma rays. The number of X-ray ports and the method of applying intracavitary dosage are otherwise the same as those for stage II.

Stage III with Vaginal Extension Below Upper Third of Vagina: In addition to the applications previously described, a tubular source is applied in the vagina, or interstitial implantation is advised. If rectovaginal or vesicovaginal fistulas result, various surgical procedures may be employed if the patient is tumor-free some months later.

Stage IV: Ordinarily, palliative external X-ray irradiation is all that can be done. In such instances the external therapy is modified. All the ports are cross fired at the cervix and vagina, rather than at the lateral pelvic wall, with conventional X ray. The mid-line lead protective strip width is reduced to 2 cm. When the disease is confined to the pelvis, 8- by 16-cm telecobalt fields may be cross fired at the cervix with 35- to 45-deg angulation and approximately 8 cm separation. A total of 6000 gamma roentgens to the cervix is the target dose. Various surgical palliative measures have also been used.¹⁴

Calculations for One Patient

Examination of a white woman, aged 34, with a history of postcoital bleeding for the past several weeks, revealed an eroded lesion of the cervix. Biopsy was reported as showing squamous-cell carcinoma, grade II. The patient was immediately referred to the gynecology tumor clinic, where the history, physical examination, blood urea, blood cellular studies, and excretory pyelograms were found to be essentially normal. After examination and review of findings by the joint gynecology-radiology conference, the lesion was designated stage I (League of Nations). The plan of treatment was therefore intracavitary irradiation, followed by external irradiation to six skin fields in the anterior, posterior, and sacrosciatic regions in five to six weeks as tolerated. The two anterior and posterior fields were to be treated individually, and a 4-cm strip of untreated skin was to be left between them down the mid-line. All beams were to be directed toward a parametrial point some 6 cm from the mid-line (anterior and posterior beams to be directed vertically downward). It was determined by probing the uterine canal that the long cervical applicator could be used.

The patient was admitted to the hospital, and general anesthesia was administered. Strong sutures were passed through the anterior and posterior lips of the cervix, and a skin clip was attached to the lateral lip of the cervix to identify this area in subsequent roentgenograms. The tandem was inserted, and the sutures were tied through the eyes provided, holding the tandem close to the cervix. The individual colpostat arms were introduced, slipped over the pins, and locked in place. A Foley bag catheter was inserted, and the bag was filled with 5 cm³ of 10 per cent sodium iodide. The colpostat arms were then spread 2 cm, the bladder and rectum were packed as well as possible, and the loose packing was applied in the vaginal vault.

The patient was then taken to the X-ray department, where a catheter was introduced into the rectum and

several ounces of a thin barium mixture were instilled by a bulb syringe. A lateral film of the pelvis (6-ft target-to-film distance) was obtained. By determination of the relation of the axis of the tandem and the plane of the sacrum, the patient was positioned for the anteroposterior view. The hips or the shoulders were elevated as needed to bring the applicator as nearly parallel with the film as possible.

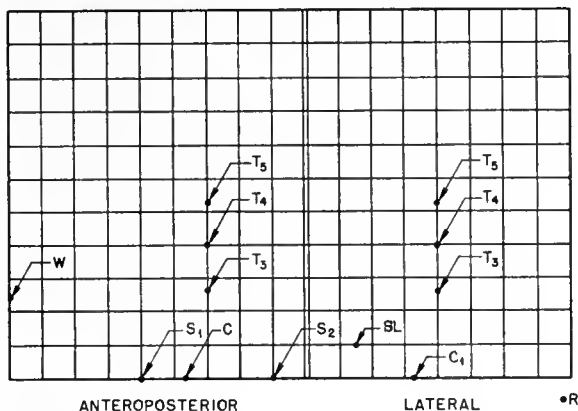

Fig. 5—Centimeter grid for a permanent record of the centers of each of the sources, as determined from films, in relation to the pelvic points on the anteroposterior and lateral projections.

As a general rule, the axis of the tandem must be at least 2.5 cm from both the rectum and bladder points if one hopes to obtain satisfactory dosage to the various other points. On the dry films the centers of the various sources can be determined and the cervix and wall points noted. Point A on either side is taken as a point 3 cm along the tandem axis and 2 cm lateral to the tandem, and the cervix is defined, these three points forming the paracervical triangle. The nearest points of rectum and bladder are marked on the film. In the 6-ft films it is possible to make measurements directly on the film because of the relatively low degree (5 to 8 per cent) of magnification. In other cases, in our practice for record purposes, the points representing landmarks actually present on the films can be transferred to a centimeter grid chart (Fig. 5) after correction for magnification. By using a common point of reference on the applicator, correction can be made by direct tracing from the radiograph. Such a grid record can be made by direct tracing from the radiograph if teleroentgenograms are used. We have included our clinical chart for reference purposes (Fig. 6).

Once the proper points are determined, we are ready to begin measurements (see Figs. 1a and 1b). (It should be emphasized that all measurements are taken from the central point in either axis.)

The first step in all patients is to determine the critical point that, as estimated by inspection, will get the greatest dosage; this will usually be the bladder, a point 5 mm nearer the applicator than the nearest point of the Foley bag. The measurements from the colpostats to the bladder are made on the lateral film (Fig. 1a). Having determined the number

SPECIAL TECHNIQUES FOR SPECIAL TUMORS

of hours the gamma-ray source can be left *in situ* without damage to the bladder, we then determine the dosage received by the index points in the pelvis. If this dosage falls below the optimum dosage (Table 1), supplementation by external irradiation will supply the deficit, particularly to point W. Calculations and estimation of the number of hours the source can be *in situ* with regard to the bladder are made as follows:

Figure 7 shows the arrangement of the cobalt source within the tandem (T₁, T₂, T₃, T₄, and T₅) and the colpostats (S₁ and S₂). The z axis is in the longitudinal line of the body, the x axis in the coronal plane, and the y axis in the sagittal. Figure 7b shows the various positions the bladder may occupy with respect to y and z.

The first measurement represents L, or distance along the same axis as the source and measured from its center. The second is H, the distance from the axis of the source. For the tandem sources the distance H is always the same as L. For the colpostat sources it is (in this patient) 2.5 cm. This measurement remains the same for all tandem sources, but the measurement along the axis of the sources varies, being 1.6, 2.9, and 4.2 cm, as one goes toward the tip of the tandem, for T₃, T₄, and T₅, respectively. Once the measurements from the various sources to the point in question are obtained, one finds the dosage rate (roentgens per millicurie-hour) from the isodose curves or from tables (Figs. 8a and 8b; Tables 2 and 3). One finds that the dosage rate to the bladder point is 0.75 r/millicurie-hr (L = 2.5; H = 1) from each of the colpostat sources. Since each contains 13.1 millicuries, the number of roentgens per hour to the bladder point from each is 9.83. Figure 8 gives the number of roentgens per millicurie-hour for the tandem source, and it is found that source T₃ (L = 1.6; H = 2.5) gives 1.3 r/millicurie-hr. Since this source is 19 millicuries, it contributes 24.7 r/hr to the bladder point. Source T₄ (L = 2.9; H = 2.5) contributes 0.75 r/millicurie-hr, and, since this source is 1.57 millicuries, it contributes 1.18 r/hr to the

Measurements to the nearest point of the rectum are similar to those of the bladder, but here the rectal point is 4 cm from the axis of the tandem, and the total contribution is not significant. If the rectum were closer to the applicator than the bladder is, the rectum would then be the limiting factor in our treatment.

Table 2—GAMMA ROENTGENS PER MILLICURIE-HOUR DELIVERED AT VARIOUS DISTANCES FROM VARIOUS POINTS ALONG LINEAR Co⁶⁰ SOURCES*†

Distance from tube, cm	Distance along tube axis, cm						
	0.0	0.5	1.5	2.0	2.5	3.0	3.5
0			4.09	2.16	1.34	0.91	0.67
0.5							
1.0	10.36	8.59					
1.5	4.77	4.37	1.85	1.17	0.87	0.65	0.51
2.0	2.74	2.59	1.53	1.04	0.72	0.56	0.45
2.5	1.76	1.72	1.18	0.91	0.67	0.51	0.40
3.0	1.25	1.20	0.92	0.75	0.80	0.46	0.37
3.5	0.91	0.90	0.72	0.62	0.52	0.42	0.35
4.0	0.69	0.69					
5.0	0.45	0.45					
6.0	0.31	0.31					
7.0	0.23	0.22					
8.0	0.18	0.18					
9.0	0.14						
10.0	0.11						

* Enclosed 1.0-cm Co⁶⁰ capsule, 3.2 mm in diameter; lead plug at each end 5.0 mm in length and 15.9 mm in diameter; filter, 6.35 mm wood and 2.2 mm brass, enclosing both wood and lead.

The clip point C lies in line with the centers of the colpostats, L is zero, and H is measured on the anteroposterior view of the x axis. The nearer of the two (H = 1.3) gives 6.3 r/millicurie-hr, and the more distant (H = 2.7) gives 1.53

Table 3—GAMMA ROENTGENS PER MILLICURIE-HOUR DELIVERED AT VARIOUS DISTANCES FROM VARIOUS POINTS ALONG LINEAR Co⁶⁰ SOURCES*†

Distance from tube, cm	Distance from center along tube axis, cm												
	0.0	0.5	1.0	1.5	2.0	2.5	3.0	3.5	4.0	4.5	5.0	5.5	6.0
0.5	35.6	24.6	9.80	4.71	2.76	1.72	1.20	0.88	0.68	0.53	0.44	0.36	0.30
1.0	10.63	8.87	5.68	3.43	2.16	1.47	1.10	0.81	0.63	0.49	0.41	0.34	0.29
1.5	4.92	4.50	3.48	2.49	1.70	1.26	0.94	0.74	0.58	0.47	0.38	0.33	0.26
2.0	2.81	2.67	2.27	1.79	1.38	1.06	0.84	0.68	0.52	0.44	0.36	0.31	0.25
2.5	1.81	1.77	1.59	1.33	1.10	0.87	0.72	0.58	0.49	0.42	0.34	0.28	0.24
3.0	1.26	1.23	1.14	1.01	0.86	0.73	0.60	0.51	0.44	0.37	0.31	0.27	0.23
3.5	0.93	0.92	0.86	0.78	0.69	0.60	0.52	0.46	0.39	0.33	0.28	0.25	0.23
4.0	0.72	0.71	0.68	0.63	0.58	0.52	0.45	0.38	0.34	0.31	0.28	0.23	0.21
4.5	0.56	0.56	0.55	0.52	0.47	0.42	0.40	0.34	0.30	0.27	0.25	0.22	0.20
5.0	0.46	0.46	0.44	0.42	0.38	0.36	0.34	0.30	0.27	0.25	0.22	0.20	0.18
5.5	0.38	0.37	0.36	0.34	0.31	0.30	0.29	0.27	0.24	0.22	0.21	0.19	0.17
6.0	0.32	0.32	0.31	0.30	0.28	0.27	0.26	0.24	0.22	0.21	0.19	0.17	0.16
6.5	0.27	0.27	0.27	0.26	0.25	0.24	0.23	0.21	0.20	0.19	0.17	0.16	0.15
7.0	0.24	0.24	0.23	0.23	0.22	0.21	0.20	0.19	0.18	0.17	0.16	0.15	0.12
7.5	0.21	0.21	0.21	0.20	0.20	0.19	0.18	0.18	0.17	0.16	0.15	0.12	0.11
8.0	0.18	0.18	0.18	0.18	0.18	0.17	0.17	0.16	0.14	0.12	0.12	0.11	0.10

* Enclosed 1.0-cm Co⁶⁰ capsule, 3.2 mm in diameter; filter, 2.0 mm brass.

bladder point. Source T₅ (L = 4.2; H = 2.5) is 3.5 millicuries and gives 0.45 r/millicurie-hr, contributing 1.58 r/hr. The bladder then receives 47 r/hr. Knowing that 4000 r is the maximum dosage we want to give to the bladder, we know that the cobalt can be left *in situ* for a period of 84 hr only.

r/millicurie-hr. Because it is constant from the axis of the tandem, the measurement H is 0.7 cm for all tandem sources. The L distances are 2.6, 3.9, and 5.2 cm for sources T₃, T₄, and T₅, respectively. From the isodose curves (Fig. 8) we find that these give 1.52, 0.69, and 0.39 r/millicurie-hr,

THE CERVIX

NAME M-----F----- UNIT NO. A-----

APPLIED BY <u>I. Meschan</u> DATE <u>5-5-53</u> TIME <u>9 A.M.</u> REMOVED BY <u>G. Regnier</u> DATE <u>5-8-53</u> TIME <u>9:05 P.M.</u> CALCULATED BY <u>T. H. Oddie</u>		TRIAL CALCULATION (BLADDER)																																																																							
TOTAL ROENTGENS (Rounded-off Figures)		<table border="1"> <tr> <th>No.</th> <th>Distances</th> <th>r/mc</th> <th>Hc</th> <th>r/hr</th> </tr> <tr> <td></td> <td>L H</td> <td>hr</td> <td></td> <td></td> </tr> <tr> <td>S1</td> <td>2.5 2</td> <td>.75</td> <td>13.1</td> <td>9.83</td> </tr> <tr> <td>S2</td> <td>2.5 2</td> <td>.75</td> <td>13.1</td> <td>9.83</td> </tr> <tr> <td>T3</td> <td>1.6 2.5</td> <td>1.3</td> <td>19.0</td> <td>24.70</td> </tr> <tr> <td>T4</td> <td>2.9 2.5</td> <td>.75</td> <td>1.57</td> <td>1.18</td> </tr> <tr> <td>T5</td> <td>4.2 2.5</td> <td>.45</td> <td>3.5</td> <td>1.58</td> </tr> <tr> <td>6</td> <td></td> <td></td> <td></td> <td></td> </tr> <tr> <td>7</td> <td></td> <td></td> <td></td> <td></td> </tr> <tr> <td>8</td> <td></td> <td></td> <td></td> <td></td> </tr> <tr> <td>9</td> <td></td> <td></td> <td></td> <td></td> </tr> <tr> <td>10</td> <td></td> <td></td> <td></td> <td></td> </tr> <tr> <td>11</td> <td></td> <td></td> <td></td> <td></td> </tr> <tr> <td>12</td> <td></td> <td></td> <td></td> <td></td> </tr> </table>		No.	Distances	r/mc	Hc	r/hr		L H	hr			S1	2.5 2	.75	13.1	9.83	S2	2.5 2	.75	13.1	9.83	T3	1.6 2.5	1.3	19.0	24.70	T4	2.9 2.5	.75	1.57	1.18	T5	4.2 2.5	.45	3.5	1.58	6					7					8					9					10					11					12				
No.	Distances	r/mc	Hc	r/hr																																																																					
	L H	hr																																																																							
S1	2.5 2	.75	13.1	9.83																																																																					
S2	2.5 2	.75	13.1	9.83																																																																					
T3	1.6 2.5	1.3	19.0	24.70																																																																					
T4	2.9 2.5	.75	1.57	1.18																																																																					
T5	4.2 2.5	.45	3.5	1.58																																																																					
6																																																																									
7																																																																									
8																																																																									
9																																																																									
10																																																																									
11																																																																									
12																																																																									
		Total r/hr to this point <u>47.1</u>																																																																							

RECTUM	R	1710
BLADDER	BL	4000
CLIP POINT	C ₁	11260
CERVIX	90°X	8100
LEFT WALL	LW	1420
RIGHT WALL	RW	1420
PARACERVICAL	A	6900

No.	Mc hr	RECTUM				CERVIX (C)				CERVIX (C ₁)			
		L	H	r/mc	Total r	L	H	r/mc	Total r	L	H	r/mc	Total r
S1	1102	4	4.2	.4	4.1	0	1.3	6.3	69.3	.7	2	2.5	27.55
S2	1102	4	4.2	.4	4.1	0	2.7	1.53	168.6	.7	2	2.5	27.55
T3	1598	2	8.4	.45	7.9	2.5	.7	1.52	24.29	2.6	.7	1.52	24.29
T4	132	4	2.4	.3	4.0	3.9	.7	.69	91	3.9	.7	.69	91
T5	244	5	5.4	.24	7.1	5.2	.7	.39	115	5.2	.7	.39	115
		TOTAL 1712				TOTAL 11264				TOTAL 8145			

No.	Mc hr	LEFT WALL				RIGHT WALL				PARACERVICAL TRIANGLE			
		L	H	r/mc	Total r	L	H	r/mc	Total r	L	H	r/mc	Total r
S1	1102					0	4.5	.55	506	0	3	1.28	141.1
S2	1102	SAME				0	8.5	.16	176	0	5	.45	496
T3	1598	AS				0	6	.33	527	.5	2	2.75	439.5
T4	132	RIGHT				1.5	6	.30	40	1	2	2.3	304
T5	294					3	6	.25	74	2.5	2	1.1	323
		TOTAL 1423				TOTAL 1423				TOTAL 6929			

Fig. 6—Permanent record for sample case completely filled out. Since there are only five sources in the applicator now being used, the entries and calculations are relatively simple. The same form, however, can be used with more complicated applicators, such as the Ernst, which has nine sources. We have applied the method to 12 sources.

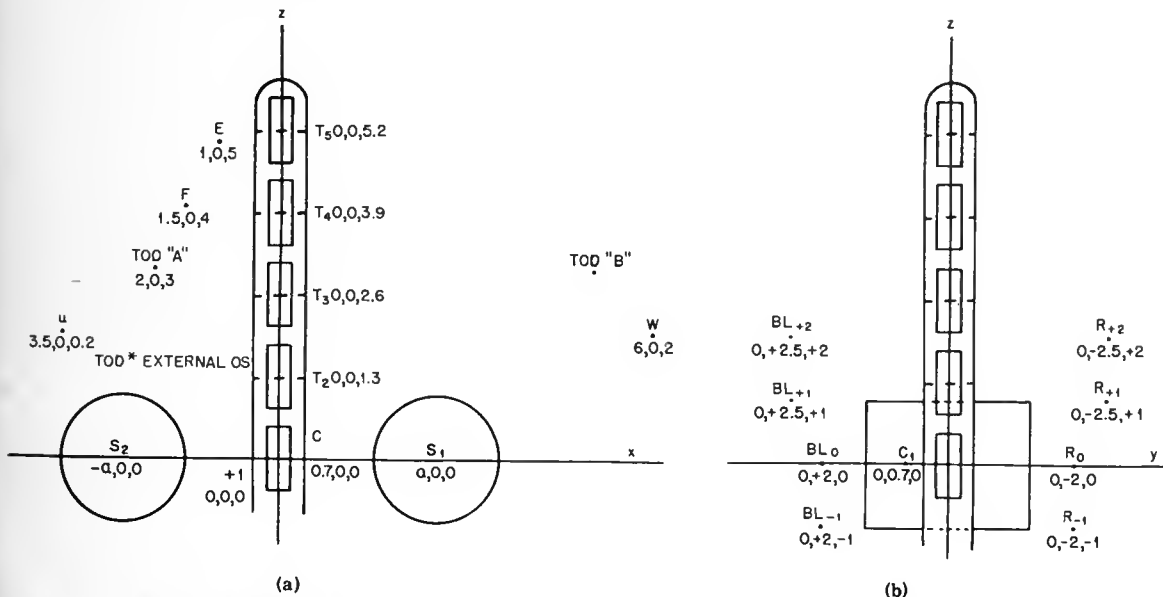

Fig. 7—Diagrams of applicator in frontal (a) and lateral (b) projections, with pelvic points also indicated. [*Tod assumed eroded cervix.]

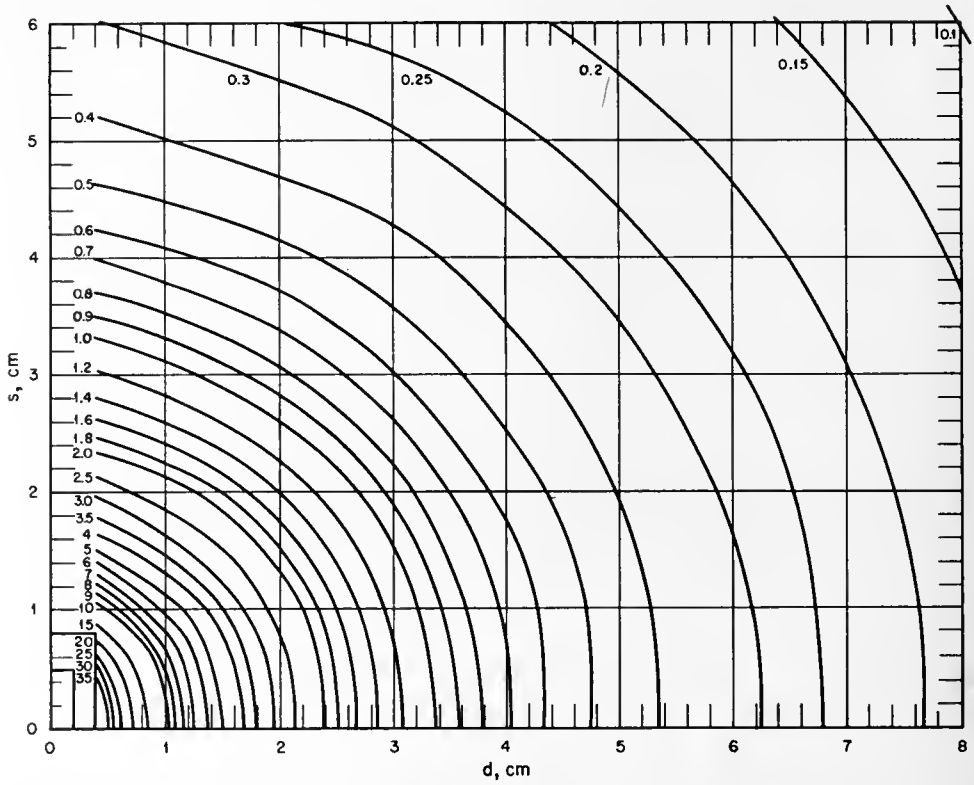

Fig. 8a—Isodose curves for the axial Co^{60} segments used in the tandem. Rates are given in roentgens per millicurie-hour.

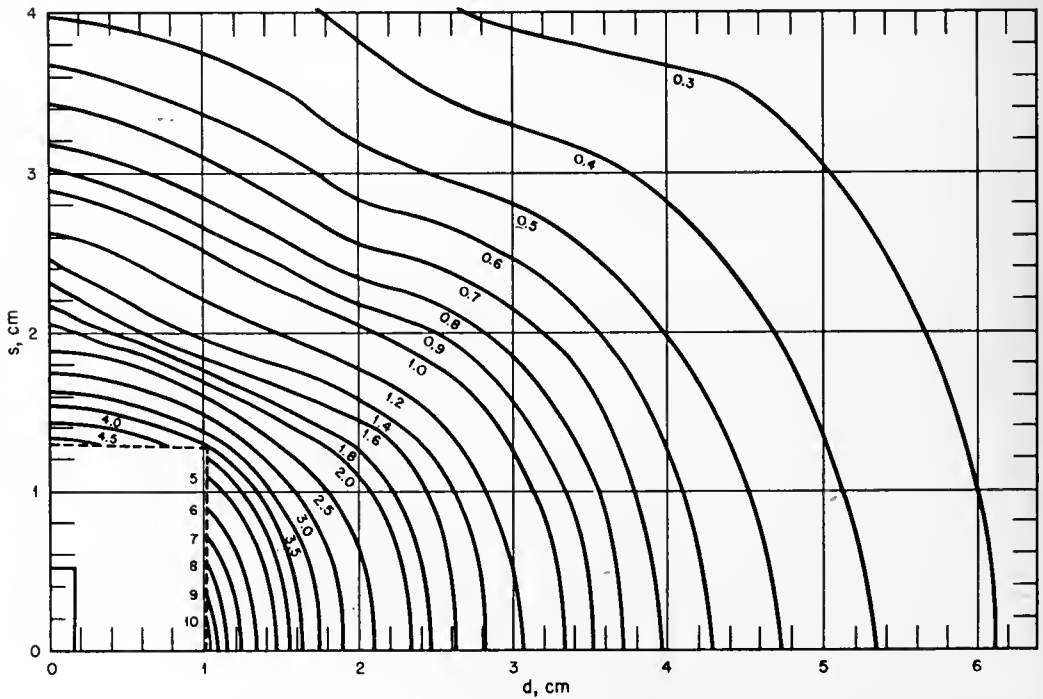

Fig. 8b—Isodose curves for the colpostat capsular sources shown in Fig. 3. Rates are given in roentgens per millicurie-hour.

respectively. Multiplication of these dosage rates by the millicurie-hours from each source gives the total number of roentgens to the clip point C (11,260 r).

The second cervix point, C_1 , is the superior lip of the cervix, which actually receives the same dosage from the tandem sources as does C. For the colpostat sources, C_1 being equidistant from the two colpostats, L is 0.7 cm rather than 1 cm, and C_1 receives a lower dosage from these two sources than does the other cervical point, C, which is not midway between the two colpostats (8100 r).

Point W lies in the central ($y = 0$) plane of the applicator, and the L distance for the colpostats is again zero. Since the distances are relatively great from these sources to the wall, the dosage rate is rather low, as is the dosage from the tandem sources. Only the right-wall point is calculated (1420 r) here, but sometimes the two points are not equidistant from the applicator, and both must be calculated.

Point A is likewise in the $y = 0$ plane of the applicator, and therefore L for the colpostat is zero. All measurements from the tandem can be made from the anteroposterior view alone. On the lateral view these points are superimposed on the tandem. This applies to the clip point C as well as to the wall point W. Point A is calculated to receive 6900 r.

Upon completion of the computations as outlined, one has the total number of roentgens that will be delivered to the various points about the pelvis during the time in which the bladder point is receiving 4000 r in a gamma irradiation period of 84 hr.

The modus operandi of this short method is as follows:

1. It is first established that the position of the applicator is symmetrical with respect to the pelvis.
2. The spread of the colpostats is noted.
3. On the lateral radiograph the bladder point is determined with respect to the z axis as BL_{-1} , BL_0 , BL_{+1} , or BL_{+2} .
4. In the appropriate columns of Table 4, for the spreader value a and the bladder point BL, the total number of millicurie-hours is obtained.
5. From Table 5, the gamma roentgen contribution to each pelvic point is indicated when the dose for S is used.

Short Method of Calculation Compared with Long Method

It is apparent from Fig. 5 that the bladder is in the +1 position on the z axis, and the spread of the colpostats is represented by a = 2 cm. From Table 4, it is found that S millicurie-hours must equal 1100. Since S contains 13.1 millicuries, the application time is 84 hr. This value agrees exactly with that calculated by the long method.

Table 4—EXPOSURE IN MILLICURIE-HOURS, S (SINGLE COLPOSTAT VALUE), WHICH MUST BE APPLIED NOT TO EXCEED 4000 GAMMA ROENTGENS TO BLADDER POINTS INDICATED AND TO ATTAIN DESIRED DOSAGE LEVELS⁷

Axial length	Colpostat setting (a), cm	S millicurie-hours for various critical bladder points			
		BL_{-1} limit	BL_0 limit	BL_{+1} limit	BL_{+2} limit
Short	1.75	1100	1030	1100	945
	2	1100	1070	1100	955
	2.5	1200	1160	1180	980
	3	1450	1270	1240	1020
Medium	1.75	1100	1030	1100	965
	2	1100	1070	1100	980
	2.5	1230	1160	1180	1010
	3	1500	1270	1240	1050
Long	1.75	1100	1030	1100	965
	2	1100	1070	1100	975
	2.5	1230	1160	1180	1010
	3	1500	1270	1240	1050

Calculation for Symmetrical Application in a Standard Pelvis

If the applicator is sewed to the cervix and if the position of the applicator is symmetrical with respect to the two pelvic walls, there are only two variables in the three-axial system: (1) the degree of separation of the colpostats and (2) the relation of the applicator to the bladder. The separation of the colpostats can be regulated by the calibrated spreaders, which are an integral part of the fixed applicator system.

The only remaining variable is the relation of the applicator to the bladder (Table 4). When the dose for S is used, it is possible to tabulate the roentgen contribution to the various pelvic points (Table 5).

From Table 5, we note the following comparisons between the dose in gamma roentgens to the various points as determined by the long method vs. the short method:

Pelvic points	C_1	A	C	W
Long method	8,100	6,900	11,260	1,420
Short method	7,900	7,900	11,200	1,450

In the short method we are using bladder measurements on the z axis which are closest to -1, 0, +1, and +2. Also the bladder position on the y axis is fixed. This, therefore, gives us a calculation sufficient for clinical application. A dose of 4000 r to the bladder is never exceeded; sometimes it may be as low as

3500 r. If doses of 7000 r or more to both point A and C₁ can be obtained with a dose to the bladder of less than 4000 r, these points are used as the limiting factor in the construction of Table 4.

The differences between the short and long methods of calculation are of academic interest only, and in the usual application the short method can be used. If the application is asymmetrical or unusual in any way, the long method should be used.

pose the previous limitations on the bladder and the rectum. Moreover, the dose delivered to the pelvic wall must be, of necessity, smaller; hence greater supplementation is required by the external irradiation.

In Table 6, the dose delivered to the various points of interest in the pelvis is briefly summated.

Since the dose to the vagina of 22,000 r is probably undesirable, we are virtually limited in our applica-

Table 5—TOTAL GAMMA ROENTGENS¹ DELIVERED TO VARIOUS PELVIC POINTS WHEN CRITICAL BLADDER POINTS ARE DOSED AS INDICATED IN TABLE 4

Axial length	Colpostat setting (a), cm	BL ₋₁ limit					BL ₀ limit				
		BL ₋₁	C ₁	A	C	W	BL ₀	C ₁	A	C	W
Short	1.75	3,480	9,600	7,000	15,200	1,360	4,000	9,000	6,600	14,200	1,280
	2	3,300	8,100	7,000	11,420	1,420	4,000	7,800	6,800	11,000	1,360
	2.5	3,310	7,000	7,500	8,330	1,650	4,000	6,800	7,200	8,090	1,800
	3	3,620	7,000	8,900	7,910	2,230	4,000	6,100	7,800	6,890	1,940
Medium	1.75	3,420	9,400	7,000	14,900	1,370	4,000	8,800	6,600	14,000	1,280
	2	3,240	7,900	7,000	11,200	1,420	4,000	7,700	6,800	10,900	1,390
	2.5	3,330	7,000	7,700	8,330	1,720	4,000	6,600	7,200	7,850	1,620
	3	3,680	7,000	9,200	7,910	2,310	4,000	5,900	7,800	6,670	1,950
Long	1.75	3,420	9,400	7,000	14,900	1,390	4,000	8,800	6,600	14,000	1,300
	2	3,240	7,900	7,000	11,200	1,450	4,000	7,700	6,800	10,900	1,410
	2.5	3,330	7,000	7,700	8,330	1,740	4,000	6,600	7,200	7,850	1,640
	3	3,680	7,000	9,200	7,910	2,310	4,000	5,900	7,800	6,670	1,950

		BL ₊₁ limit					BL ₊₂ limit				
		BL ₊₁	C ₁	A	C	W	BL ₊₂	C ₁	A	C	W
Short	1.75	4,000	9,600	7,000	15,200	1,360	4,000	8,200	6,000	13,000	1,160
	2	4,000	8,100	7,000	11,400	1,420	4,000	7,000	6,100	9,870	1,220
	2.5	4,000	6,900	7,400	8,210	1,630	4,000	5,700	6,100	6,780	1,340
	3	4,000	6,000	7,600	6,780	1,910	4,000	4,900	6,200	5,540	1,560
Medium	1.75	3,870	9,400	7,000	14,900	1,370	4,000	8,300	6,200	13,200	1,210
	2	3,800	7,900	7,000	11,200	1,420	4,000	7,000	6,200	9,940	1,260
	2.5	4,000	6,700	7,400	7,970	1,640	4,000	5,700	6,300	6,780	1,400
	3	4,000	5,800	7,600	6,550	1,910	4,000	4,900	6,400	5,540	1,620
Long	1.75	3,880	9,400	7,000	14,900	1,390	4,000	8,300	6,100	13,200	1,230
	2	3,820	7,900	7,000	11,200	1,450	4,000	7,000	6,200	9,940	1,280
	2.5	4,000	6,700	7,400	7,980	1,660	4,000	5,700	6,300	6,780	1,410
	3	4,000	5,800	7,600	6,550	1,910	4,000	4,900	6,400	5,540	1,620

Table 6—DATA FOR COLPOSTAT USED ALONE (NO TANDEM POSSIBLE)*†

Colpostat setting (a), cm	R/mc-hr in S	S, mc-hr	Time if S = 13.1 mc, hr	Dose to vagina, r	Dose to pelvic wall, r	Dose to C, r	Dose to C ₁ , r	Dose to A, r
1.75	6.2	1,130	86	12,000	780	12,700	7,010	1,970
2	4.8	1,460	111	15,500	1,070	11,400	7,000	2,510
2.5†	3.32	2,110	181	22,400†	1,750	9,300	7,000	3,400

* Exposures for a minimum dose of 7000 r at point C₁, with the bladder receiving a maximum of 4000 r.

† Dose to vagina possibly excessive and hence possibly not desirable.

Special Case of Cervical Stump

In some patients tandem insertion is not possible, and colpostats must be used alone. In these patients, Tod's point A cannot receive 7000 r, but we still im-

tion to the a = 2-cm or 1.75-cm setting, the 2.0-cm setting being the more desirable since the dose to the pelvic wall is greater. The dose to point A is 2500 r, which is too low for metastases in this region. We have on occasion used a cylindrical needle implant in

THE CERVIX

Table 7—DOSAGE RATES AT VARIOUS POINTS IN THE PELVIS FOR 1 MILLICURIE OF Co⁶⁰ IN EACH SOURCE OF SPECIAL APPLICATOR⁵

Source	Colpostat setting (a), cm	Dosage rates, r/hr										
		C	C ₁	A	E	F	BL ₋₁	BL ₀	BL ₊₁	BL ₊₂	W	
T ₁		21	21	0.83				2.30	2.8	1.60	1.10	0.29
T ₂		5.1	5.1	1.62				1.10	2.0	1.78	1.70	0.32
T ₃		1.50	1.50	2.75	1.61	2.71	0.63	1.00	1.28	1.74	1.74	0.33
T ₄		0.70	0.70	2.35	5.1	4.9	0.37	0.56	0.74	1.14	0.29	
T ₅		0.39	0.39	1.25	10.0	3.0	0.24	0.34	0.46	0.66	0.25	
S ₁ + S ₂	1.75	11.2	6.2	1.74	0.80	1.12	2.10	2.24	1.46	1.30	0.69	
S ₁ + S ₂	2.0	7.8	4.8	1.72	0.77	1.08	1.94	2.10	1.40	1.26	0.73	
S ₁ + S ₂	2.5	4.41	3.32	1.61	0.72	1.01	1.70	1.81	1.30	1.14	0.83	
S ₁ + S ₂	3.0	2.91	2.30	1.49	0.67	0.92	1.44	1.51	1.14	0.98	0.98	

Table 8—COMBINED DOSAGE RATES AND RATIOS OF RATES FOR STRENGTH S = 1 MILLICURIE IN THE SPECIAL RIGID APPLICATOR⁵

Assembly	Colpostat setting (a), cm	Dosage rates, r/hr						Ratio of rates			
		C	C ₁	A	D	E	W	C/C ₁	F/A	E/A	W/C ₁
Short	1.75	13.8	8.7	6.4	5.7	3.5	1.24	1.58	0.89	0.55	0.142
	2	10.3	7.3	6.3	5.6	3.5	1.28	1.41			0.175
	2.5	6.9	5.8	6.2	5.6	3.4	1.38	1.19			0.236
	3	5.4	4.8	6.1	5.5	3.4	1.53	1.13			0.318
Medium	1.75	13.6	8.6	6.4	6.4	4.5	1.25	1.59	1.0	0.71	0.146
	2	10.2	7.2	6.3	6.3	4.5	1.29	1.42			0.180
	2.5	6.8	5.7	6.2	6.2	4.4	1.39	1.19			0.245
	3	5.3	4.7	6.1	6.2	4.4	1.54	1.13			0.330
Long	1.75	13.6	8.6	6.4	6.4	6.4	1.27	1.59	1.0	1.0	0.148
	2	10.2	7.2	6.3	6.4	6.4	1.31	1.42			0.183
	2.5	6.8	5.7	6.2	6.3	6.4	1.41	1.19			0.248
	3	5.3	4.7	6.1	6.2	6.3	1.56	1.13			0.330

Table 9—DOSE⁶ AT VAGINAL POINTS V₁ AND V₂ FOR APPLICATORS AS SHOWN IN TABLES 4 AND 5

	V ₁		V ₂	
	S (max.), mc-hr	R (max.)	S (max.), mc-hr	R (max.)
Short applicator:				
a = 3 cm*	1,450	18,000	1,450	16,800
a = 2.5 cm	1,200	14,900	1,200	13,900
Medium applicator:				
a = 3 cm*	1,500	18,600	1,500	17,300
a = 2.5 cm	1,230	15,300	1,230	14,200
Long applicator:				
a = 3 cm*	1,500	18,600	1,500	17,300
a = 2.5 cm	1,230	15,300	1,230	14,200

* a = 3 cm would be the worst possible case and would not be recommended for use in any patient. a = 2.5 cm and a = 2 cm are recommended. (Values for a = 2 cm are approximately 8 per cent less than for a = 2.5 cm.)

the cervical stump to bring this dosage up. A better expedient is to create a short applicator by inserting blunt additional needles into the center of the cervical stump, with a loading similar to that recommended for the short tandem, loading the T_3 position only, with the center of this source at 2.6 cm on the z axis. This needle would need to have a minimum length of 3.3 cm, which would penetrate the upper end of the cervical stump. The danger of such a technique would be possible overirradiation of a section of loop of small bowel. In actual practice the latter method seems to work well without significant complication.

Tripartite Rigid Co^{60} Applicator

Further basic physical considerations in the use of the Co^{60} applicator for treatment of carcinoma of the cervix described include the following:

1. The determination of the required radioactivity in each capsule.
2. The selection of the total capsular strength of each capsule to give optional radiation time.
3. A method of adjustment of the Co^{60} intensity within the capsules to obtain precisely the desired total strengths.

Distribution of Radioactivity in Applicator

The gamma dosage requirements that have been specified may be represented as:

- D_C : 7000 r minimum
 D_{C_1} : 7000 r minimum
 D_{BL} : 4000 r maximum
 D_W : as high as possible

where D_C is the gamma dose at point C, D_{BL} is the dose to the bladder point, etc. [D_{BL} represents the dose at any four bladder points (-1, 0, +1, or +2) considered on the z axis. In the y axis (sagittal plane) these points are at 2.0, 2.0, 2.5, and 2.5 cm respectively. All four of these points are at 0 on the x axis.]

Table 7 presents the calculated individual dosage rates at the various pelvic points when 1 millicurie of Co^{60} is contained in each source indicated and when the colpostat setting is as shown.

From the values given in Table 7, it is seen that ratios are not very critical and have therefore been further modified for convenience as follows:

Assembly	T_3/S	T_4/S	T_5/S
Short	1.68		
Medium	1.45	0.27	
Long	1.45	0.12	0.27

With these ratios and the individual dose rates of Table 7, the combined dose rates for strength $S = 1$ millicurie have been calculated for the selected points and are given in Table 8.

From the physical calculations it can be derived that the most desirable dosage distributions are obtained when the bladder point is in a negative or zero position with reference to the z axis. Unfortunately, this ideal is not always obtainable. Point BL_{+2} is the worst position of the four considered for the bladder to occupy, and BL_0 is next, followed by BL_{+1} ; BL_{-1} is the best. If the bladder point is at a position higher than $z = +2$ cm, it is probable that an inadequate dosage distribution will be obtained, and the supplementation by transvaginal X-ray and external irradiation will be necessary.

It is also noted that the dose to the cervix under these circumstances is frequently low with the 3.0-cm spread of the colpostats, and this spread should be avoided if possible. Hence, wherever possible, a more desirable distribution of dose is obtained with the smaller degrees of spread of the colpostats.

It is noteworthy that, if one uses the tables, a critical dose to the bladder and rectum of 4000 gamma roentgens is never exceeded.

It is probably also of some practical importance to know the dosage levels attained in the vaginal mucosa immediately adjoining the colpostats. For this purpose we have calculated the dosage delivered to two vaginal points within and adjoining the vaginal lateral fornix as indicated in the diagram accompanying Table 9. One of these points, V_1 , is opposite the center of the colpostat source, S, where the colpostat makes contact with the vaginal fornix ($x = a$, $y = 0$, $z = 1$). A vaginal point 90 deg around the colpostat from V_1 ($x = a + 1$, $y = 0$, $z = 0$) we designate as V_2 .

The dosage delivered to these points has been calculated in each instance for the maximum number of millicurie-hours for each applicator and for distances $a = 3$ and $a = 2.5$. Our prime interest is in $a = 2.5$ (and $a = 2.0$, which is approximately 8 per cent less than the $a = 2.5$ values). It will be noted that the dosage delivered to these vaginal points is on the order of 14,000 to 15,000 r maximum, a considerable improvement over the enormous dosage levels obtained with the Ernst applicator (frequently in excess of 25,000 r).

Selection of Total Radioactive Strength in Applicator

From Table 4 it is evident that S varies from 945 to 1500 millicurie-hours; it is practically convenient to choose the amount of Co^{60} upon the first loading to give exposure times of between three and five days. Thus, if S is made 13.1 millicuries, the exposure time will be between 72 and 114 hr, usually 84 hr. Table 10 lists some convenient source strengths.

Table 10—CONVENIENT SOURCE STRENGTHS IN MILLICURIES WHEN LOADED*

Assembly	S_1	S_2	T_3	T_4	T_5	Total
Short	13.1	13.1	22.0			48.2
Medium	13.1	13.1	19.0	3.5		48.7
Long	13.1	13.1	19.0	1.57	3.5	50.27

* T_1 and T_2 contain no activity.

After radioactive decay for about 3.6 years, the exposure times will have increased to the range of 115 to 192 hr, and it will then probably be necessary to reload the applicator.

THE CERVIX

SECTION AA

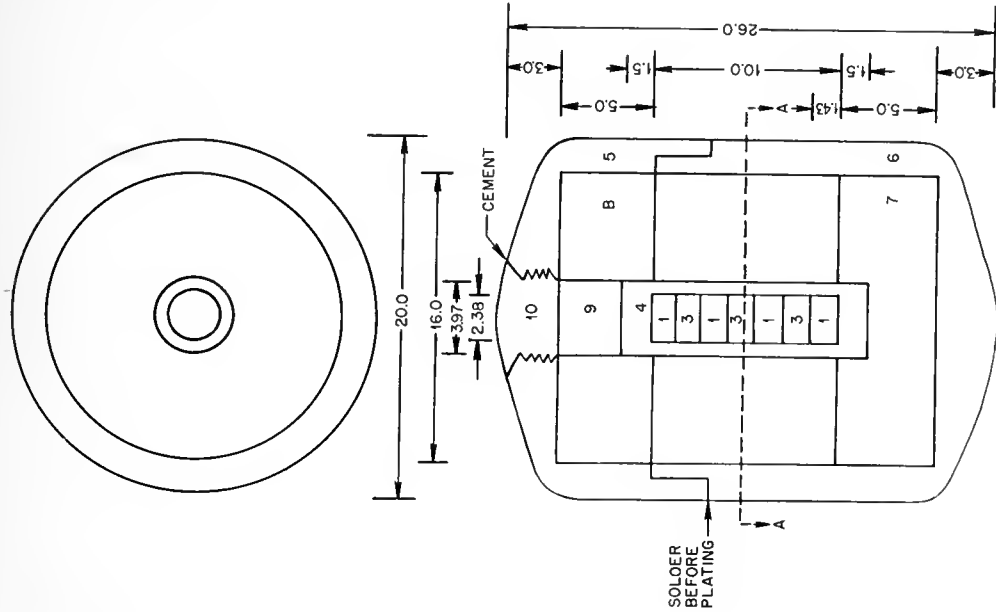

SECTION BB

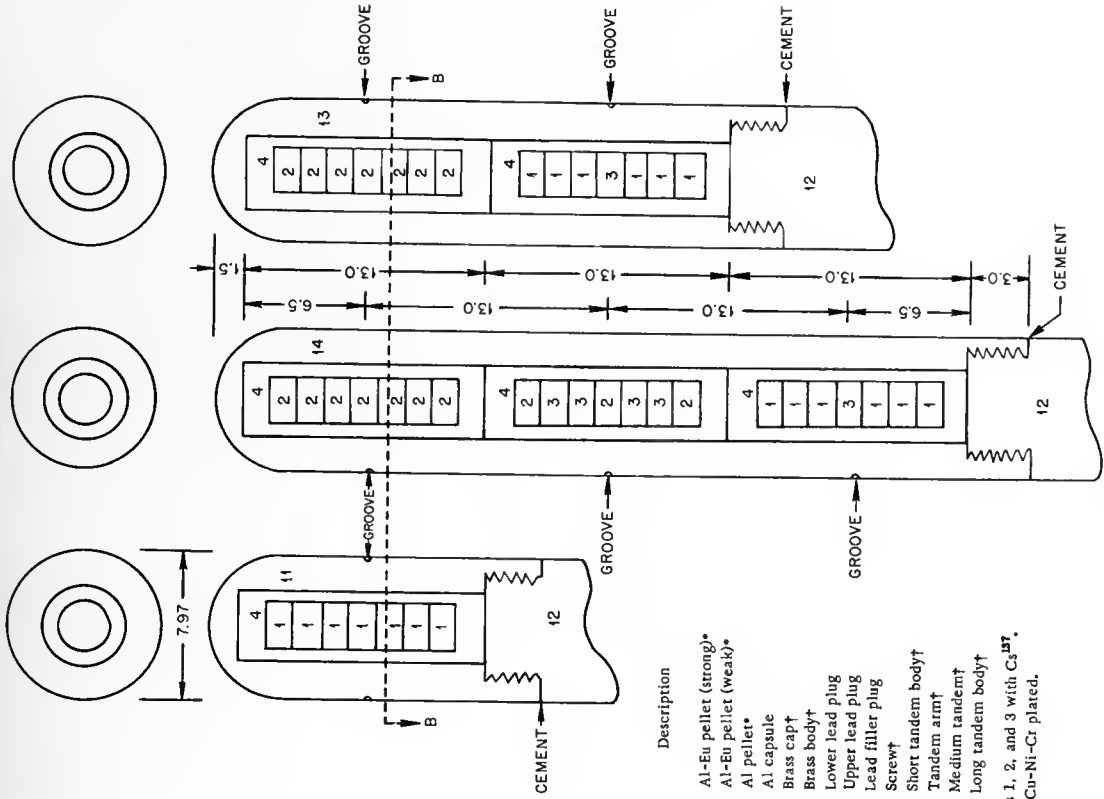

Part No.	Quantity	Description
1	27	Al-Eu pellet (strong)*
2	17	Al-Eu pellet (weak)*
3	12	Al pellet*
4	8	Al capsule
5	2	Brass cap†
6	2	Brass body†
7	2	Lower lead plug
8	2	Upper lead plug
9	2	Lead filler plug
10	2	Screw†
11	1	Short tandem body†
12	3	Tandem arm†
13	4	Medium tandem†
14	1	Long tandem body†

* OR replace parts 1, 2, and 3 with Cs¹³⁷.
 † Brass or monel, Cu-Ni-Cr plated.

Fig. 9—Diagram illustrating construction of cervix applicator and system of loading europium pellets into the applicator. Dimensions are in millimeters.

In a busy clinic such as ours, we have found that it is desirable to keep two of each of three types of applicators on hand and intact to assure a minimum of handling and exposure. The Co^{60} is obtained quite cheaply, and the six applicators are relatively inexpensive.

Adjusting Minor Variations in Co^{60} Capsules

To load the applicators with Co^{60} sources of the desired strengths, it will usually be necessary to provide some means of adjustment because sources obtained from the pile irradiation of cobalt metal will be subject to rather wide variations from their nominal radioactive content.

We have effected this adjustment by building up each 1-cm unit for the applicator from irradiated and dummy cobalt beads to an external diameter of 3.2 mm and internal diameter of 1.2 mm. The irradiated beads are 2.4 mm long. When two or three beads are used, one or two dummy spacers are added to bring the total length to 10 mm. Then a final strength adjustment is made with a piece of irradiated cobalt wire 1 mm in diameter and up to 10 mm long, which is pushed down the axial hole into the assembled beads. In this way we can cope with variations in the normal strength of the sources of ± 30 per cent.

$\text{Eu}^{152,154}$ in a Cervical Carcinoma Applicator

The chief disadvantage of Co^{60} is the half life, which is 5.3 years. Relatively frequent decay corrections and rather long treatment times after two years are necessary. Because of this disadvantage the applicator has been modified to use $\text{Eu}^{152,154}$, which has a half life of 12.4 years.¹⁵

Unlike Co^{60} , which in its decay emits gamma rays of two similar energies, $\text{Eu}^{152,154}$ emits a complex array of about 11 gamma-ray energies, ranging from 0.040 to 1.40 Mev. When relatively small amounts of filtration are applied, the average emission is not too dissimilar from that of Co^{60} .

$\text{Eu}^{152,154}$ is derived by neutron capture and gamma emission from stable Eu^{151} and Eu^{153} ; the isotopes have high neutron-capture cross sections. The source used in our applicator required irradiation for two weeks in a reactor at a flux density of about 10^{13} neutrons/cm²/sec. Very little Eu^{154} is produced in such a short neutron irradiation.

The radioactive strengths of the sources were expressed as equivalent amounts of Co^{60} by direct gamma-ray comparison at 1 meter with a Lauritzen electroscope. The actual strength of the source could not be predicted with greater accuracy than ± 15 per cent. It is not proportional to the mass of Eu_2O_3 in the capsule, presumably owing to the shielding of the inner parts of a pellet and the high cross section for

neutron absorption of the various isotopes and their daughters.

Since europium for irradiation in the pile is available only as Eu_2O_3 powder, which first has to be pelleted and sealed hermetically, the individual sources are pellets of Eu_2O_3 powder, admixed with aluminum. Aluminum pellets of appropriate size are used as inert separators, and all are enclosed in thin-walled aluminum capsules. [The materials used for molding the pellets are (1) powdered Eu_2O_3 (99.8 per cent pure), lot 421, obtained from Research Chemicals, Inc., 831 North Lake Street, Burbank, Calif., and (2) aluminum powder (-40 mesh), obtained from A. D. Mackay, Inc., 198 Broadway, New York 38, New York. Molding and measurement of the $\text{Eu}^{152,154}$ pellets was carried out by the Medical Division of the Oak Ridge Institute of Nuclear Studies.]

Each source capsule is designed to have an active length of 1 cm (Fig. 9). Each consists of seven pellets of 2.38 mm diameter and 1.43 mm length, within a cylindrical aluminum can of 3.97 mm over-all diameter and of 13.0 mm length. After loading, the end of the aluminum cylinder was sealed by spinning. No heat was used in the molding of the pellets, which was performed in a specially constructed 12-cavity mold.

Only slight variations in design were made from the original tripartite Co^{60} cervix applicator to accommodate the europium pellets and capsules. The major difference was the slightly thinner lead absorber located centrally at either end of the colpostat capsule (reduced by 1.5 mm at each end) to accommodate the 1.3-cm aluminum container into which the europium pellets were loaded. The dosimetry patterns previously established for use with the Co^{60} applicator can thus be readily applied.

The chief advantage of the europium applicator in comparison with its Co^{60} counterpart is the longer half life of $\text{Eu}^{152,154}$; its uses are otherwise the same.

It is difficult at this time to compare relative cost because the high initial costs for europium and its molding, irradiation, and loading were on an experimental basis. It is reasonable to expect that such sources can be made and molded at less cost than Co^{60} .

References

1. M. C. Tod, The Optimum Dosage in the Treatment of Carcinoma of the Uterine Cervix by Radiation, *Brit. J. Radiol.*, 14: 23-29 (January 1941).
2. L. A. Campbell, Carcinoma of the Cervix, An Applicator for Greater Parametrial Dosage, *Am. J. Roentgenol. Radium Therapy*, 57: 697-702 (June 1947).
3. E. C. Ernst, Intracavitary Radium for Cancer of the Cervix, in "Clinical Therapeutic Radiology," U. V. Portmann, editor, Thomas Nelson & Sons, New York, 1950, pp. 361-392.
4. W. G. Cuscaden and T. H. Oddie, A Dosage System of Cervical Cancer, *Med. J. Australia*, 2: 1112-1121 (Dec. 25, 1937).
5. G. H. Fletcher, Cervical Radium Applicators with Screening in the Direction of Bladder and Rectum, *Radiology*, 60: 77-84 (January 1953).

THE CERVIX

6. G. H. Fletcher, R. J. Shalek, J. A. Wall, and F. G. Bloedorn, A Physical Approach to the Design of Applicators in Radium Therapy of Cancer of the Cervix Uteri, *Am. J. Roentgenol. Radium Therapy Nuclear Med.*, 68: 935-949 (December 1952).
7. I. Meschan, T. H. Oddie, and G. Regnier, A Method of Dosimetry for Carcinoma of the Cervix Utilizing a Modified Manchester Technic with Cobalt 60, *Radiology*, 64: 546-559 (April 1955).
8. T. H. Oddie and I. Meschan, The Physical Aspects of the Utilization of the Tripartite Rigid Cobalt 60 Applicator for the Treatment of Carcinoma of the Cervix, *Radiology*, 64: 560-566 (April 1955).
9. I. Meschan, T. H. Oddie, and M. Brucer, The Utilization of Europium 152-154 in a Cervical Carcinoma Applicator, *Radiology*, 67: 422-423 (September 1956).
10. W. E. Brown, I. Meschan, E. Kerekes, and J. M. Sadler, Effect of Radiation on Metastatic Pelvic Lymph Node Involvement in Carcinoma of the Cervix, *Am. J. Obstet. Gynecol.*, 62: 871-889 (October 1951).
11. F. J. Taussig, Iliac Lymphadenectomy for Group II Cancer of the Cervix, Technique and 5 Year Results in 175 Cases, *Am. J. Obstet. Gynecol.*, 45: 733-748 (May 1943).
12. D. G. Morton, Pelvic Lymphadenectomy in the Treatment of Cervical Cancer, *Am. J. Obstet. Gynecol.*, 49: 19-31 (January 1945).
13. E. Henriksen, The Lymphatic Spread of Carcinoma of the Cervix and of the Body of the Uterus, A Study of 420 Necropsies, *Am. J. Obstet. Gynecol.*, 58: 924-942 (November 1949).
14. I. Meschan, W. E. Brown, and G. Regnier, An Experimental Evaluation of Radical Pelvic Surgery Following Radical Radiation in Treatment of Carcinoma of the Cervix and a Microscopic Evaluation of the Surgical Tissues So Obtained, *Mississippi Valley Med. J.*, 74: 162-167 (November 1952).
15. Nuclear Data, National Bureau of Standards Circular No. 499, with Supplements, U. S. Government Printing Office, Washington, D. C., 1950-1952.

The Brain

CHAPTER 45

Jacob R. Freid

Montefiore Hospital
New York, New York

Principles of Glioma Treatment

The topic assigned me is not of my choosing. Although I have treated a number of brain tumors with 200- to 400-kv X rays, only about 30 have been irradiated with Co^{60} gamma rays. Considering the different glioma types, this number is too small to allow any conclusions to be drawn, but it does permit a discussion of the principles of treatment of glioma with conventional, as well as supervoltage, irradiation.

At Montefiore Hospital, accurate beam direction through multiple portals is the technique of choice for the treatment of brain tumors with a Co^{60} unit. Because of the high depth dose from Co^{60} , little is gained with rotation techniques. In addition, the proximity of the eyes to the field of irradiation makes rotation hazardous for lesions in the frontal and temporal regions.

Great care is taken in planning the treatment to give the normal tissues surrounding the tumor minimal radiation. This is feasible for small growths, such as pituitary adenoma. Unfortunately, for many gliomas and for metastases to the brain, large fields are indicated; therefore considerable normal brain tissue must be irradiated. The site of the tumor determines the arrangement of portals suitable for the treatment. We have no standard technique, and each case is individually planned.

Figure 1 is a transverse plane through a glioblastoma multiforme in the left parieto-occipital region; the tumor is irradiated through three portals. The maximum surface dose to each portal is 3000 r. The tumor dose is 5500 r. Note the sharp fall-off in dose in the normal tissues surrounding the growth.

Figure 2 is a coronal plane of the skull through a pituitary adenoma. Treatment was given through four portals: right and left lateral temporal and two oblique portals through the vertex in the right and left frontal regions.

For accurate beam direction a cast is made of the skull of most patients treated. Patients are irradiated five times weekly. The average treatment period is six to seven weeks. In treatment of medulloblastoma, cerebellar sarcoma, and ependymoma, the entire spinal axis is also irradiated because seeding sometimes occurs in the subarachnoid spaces. The dose to the spinal axis is less than that given to the primary tumor and rarely exceeds 4000 r. Clinically, this dose is apparently sufficient to destroy seedings. The daily dose to the primary neoplasm is 150 to 200 r, and the total dose ranges from 5000 to 7000 r.

Patients have not suffered general reactions during treatment, and local reactions have been less in number and severity than those caused by conventional radiation. Epilation, usually temporary, occurs in most treated areas, generally at the level of 2000 r or more.

Types of Glioma

Because of certain characteristics the various glioma types must be considered individually when discussing response to irradiation.

Glioblastoma Multiforme

Glioblastoma multiforme comprises the largest subdivision of the gliomas. It is located almost exclusively in the cerebral hemispheres of adults. Growth is rapid and by infiltration. The average survival period, from the onset of symptoms to the death of the patient, is usually 12 months.

As the name implies, these tumors show considerable divergence in microscopic appearance. The cells are often embryonal in nature, have many mitotic figures, and differ greatly in size and shape. The blood vessels are numerous, with thin walls and frequent areas of degeneration. Hemorrhage and areas of necrosis are common.

Histologic changes following irradiation are difficult to evaluate because structure varies greatly in

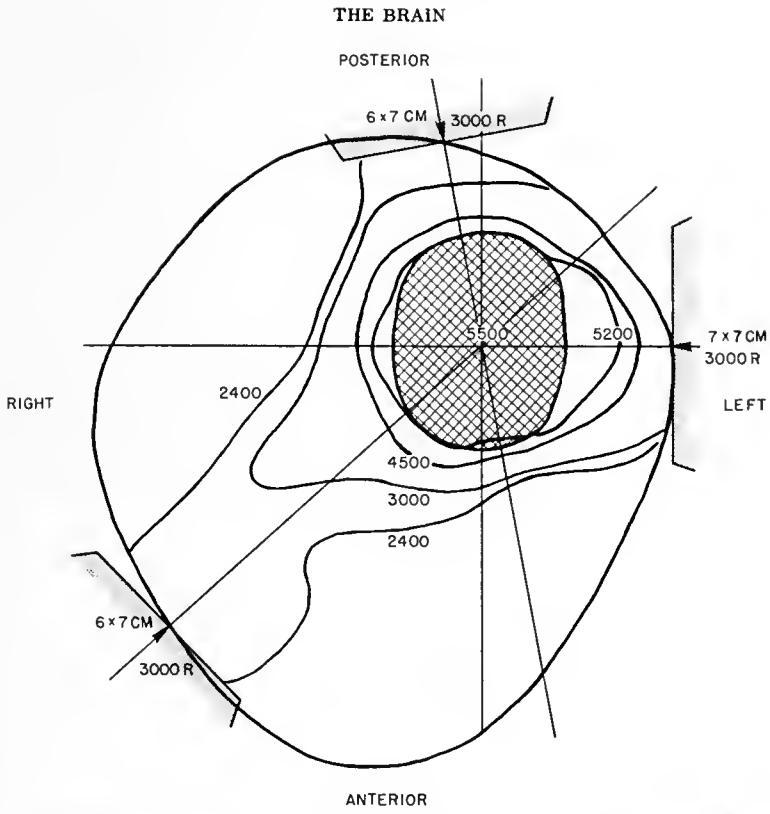

Fig. 1—Treatment of glioblastoma multiforme (three portals; transverse plane; Co⁶⁰; 80 cm SSD).

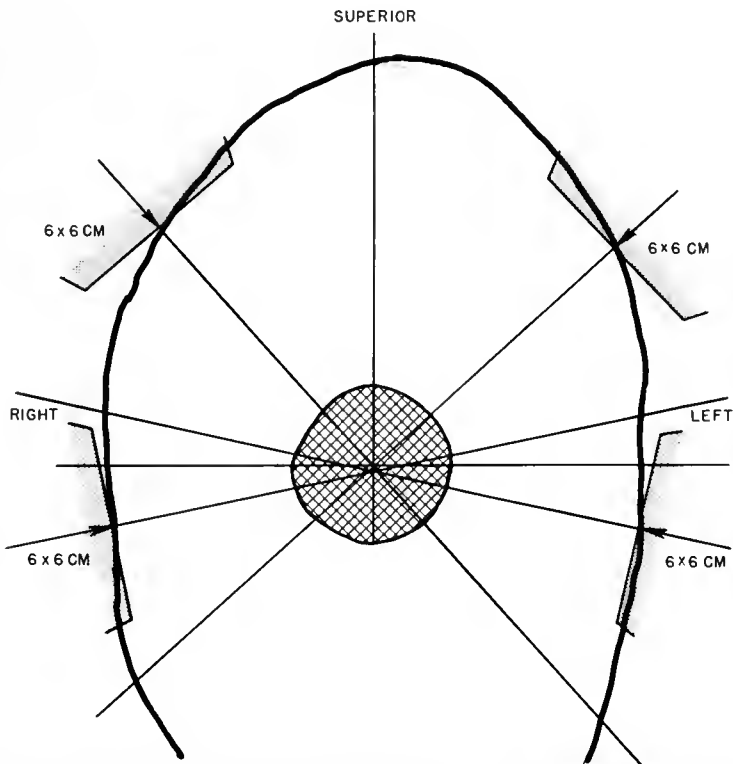

Fig. 2—Treatment of pituitary adenoma (four portals; coronal plane; Co⁶⁰; 80 cm SSD).

different portions of the tumor and the degenerative changes which occur spontaneously simulate irradiation effects.

These tumors are considered slightly radiosensitive to 200- to 400-kv radiation. The effect of super-voltage irradiation on these growths is more difficult to assess. The literature contains only two or three such reports, of very limited extent.

A. Arnold, P. Bailey, R. A. Harvey, and L. L. Haas report 16 malignant brain tumors treated with a betatron, 9 of which were glioblastoma multiforme. Tumor dose varied from 5500 to 6500 r in 17 to 30 days to 7500 r in 26 to 30 days. Of the patients with glioblastoma, five had useful survival for 14 to 21 months.

We treated 12 patients with glioblastoma multiforme with Co⁶⁰ beam therapy. Two improved and are living, five to six months following the irradiation. A third patient, with a tumor dose of 6000 r, was improved for 15 months, then had a recurrence, was given another 5000 r, and is still living, apparently comfortably, after another 15 months. Four patients had good early response but died within 12 months, and five were not improved.

A survey of the gliomas treated at Montefiore Hospital with 200- to 400-kv radiation showed that length of survival was not related to higher dosage. Survival also was not influenced by the mode of irradiation, i.e., one moderately intense series of treatments as compared to several less intense courses usually given at monthly intervals.

Survival is influenced by the course of the disease. In one patient symptoms were present for four years before operation. The operative procedure was decompression and biopsy, followed by irradiation with a tumor dose of 4500 r. The patient was symptom-free for another four years; then a recurrence developed for which he received additional irradiation. His total survival was 14 years from the onset of symptoms.

The occurrence of a long period during which symptoms were present but not severe enough to cause the patient great discomfort is not an isolated event and has occurred in other cases. It demonstrates that glioblastoma multiforme sometimes may have a long latent period during which the patients do very well because growth is slow. Once the disease has lost this latency, growth is rapid, and the patients then do very badly.

Astrocytoma

Astrocytoma is second in frequency among the gliomas. It grows slowly, is usually relatively benign, and occurs anywhere in the brain. There are two types, protoplasmic and fibrillary, but many are mixtures of both types. The tumors are often cystic, and small cavities frequently coalesce to form large cysts.

Blood vessels do not show the abnormalities noted in glioblastoma multiforme. Average survival without irradiation is 67 months for the protoplasmic

and 86 for the fibrillary types. They have a limited radiosensitivity with 200- to 400-kv radiation.

Seven patients with astrocytoma were treated with Co⁶⁰ beam therapy. Four are living 6 to 30 months following irradiation. One patient had a good early response but died within a year.

The relation of survival period to the amount of 200- to 400-kv radiation received was investigated. Some patients with large total doses lived for short periods. The longest survivals were associated with the large tumor doses, but the value of this observation is limited because the group was rather small.

The prognosis differs for cerebral and cerebellar astrocytoma. The cerebellar lesion is preponderant in young persons. Survival following operation and irradiation is much longer for this group. As anticipated, patients with astrocytoma treated with Co⁶⁰ beam therapy responded much better than those with glioblastoma multiforme.

Medulloblastoma

Medulloblastoma comprises the third largest group of gliomas. It occurs chiefly in children, rarely in adults, and lies almost invariably in the cerebellum or its immediate neighborhood. It is composed of very embryonic undifferentiated cells of neuro-epithelial origin and is extremely vascular.

In children the growth is located principally in the mid-line, whereas in adults it is most frequently in the cerebellar hemispheres. Without irradiation the average survival is 15 months, but the survival for adults appears to be longer than that for children.

We irradiated two patients with Co⁶⁰ beam therapy. The early response was good, but the patients did badly and died within a year. I do not believe this is any criterion of what can be accomplished with Co⁶⁰ beam therapy because with conventional therapy we have had patients who have lived for a good many years.

Spongioblastoma Polare

Spongioblastoma polare is a relatively slow-growing tumor, with a predilection for the brain stem; it is especially common along the optic tracts and pons. The tumor is grayish, avascular, and firm, with little tendency to cystic degeneration. It is composed mainly of bipolar and unipolar cells, which resemble the spongioblasts of the developing brain. These tumors occur principally in children. Response to conventional irradiation is poor. The average survival period without radiotherapy is about four years.

One 30-year-old patient in this group did well for one year following conventional irradiation. A recurrence developed, and she was treated with Co⁶⁰ beam therapy; she survived an additional 10 months, after which she died.

Ependymoma

Ependymoma originates along the walls of the ventricles, especially the fourth ventricle. Because of

the principal location in the fourth ventricle, it blocks circulation of the cerebral spinal fluid.

Microscopically it is composed of ependymal cells or ependymoblasts. Occasionally it produces intraspinal implantations. The average survival period without irradiation is 25 months.

Three patients were treated with Co^{60} beam therapy. One boy of seven is alive and well, more than 20 months after treatment. A young woman of 26 did well for two and one-half years; she then developed a recurrence for which she was given an additional course of irradiation. She is now well and asymptomatic eight months after the second course of treatment. A third patient was improved for seven months, then developed a recurrence, and died following a second operation.

Oligodendroglioma

Oligodendroglioma occurs almost exclusively in the cerebral hemispheres of adults. It is relatively benign, grows slowly, and permits an average survival of 66 months. Occasionally a lesion may run a more malignant course. Hemorrhage and cystic degeneration are uncommon.

Two patients were treated with Co^{60} beam therapy. One, a woman of 56, did well for two years following incomplete surgery and then developed symptoms of recurrence for which she was irradiated. Her immediate response was remarkable, and she has remained well up to the present, one year postirradiation. The second patient did poorly.

Meningioma

Meningioma is considered to be a mixture of endothelial and fibroblastic tissues, with one or the other predominating. It is a tumor of adult life, it grows slowly, and it may occur anywhere over the convexity or poles of the cerebrum or along the falx cerebri. The vast majority are concentrated in the parasagittal central region. It compresses the nerve tissue but does not invade the brain.

Postoperative irradiation has been tried, following incomplete removal, with indifferent results. The irradiation response is dependent on the amount of fibroblastic tissue in the tumor. Since the connective tissue elements predominate in most growths, the response to irradiation is poor.

Three patients were treated with Co^{60} beam therapy. One patient is living and well, 13 months after irradiation. One patient is markedly improved, four months after irradiation. A third patient did well but has been lost to follow-up studies.

Conclusions

In irradiating brain tumors, maximum tumor doses with 200- to 400-kv irradiation are not always associated with correspondingly good clinical responses. In cases described by T. J. Wachowski and Chenault, despite severe injury to normal nerve tissue, the tumors were never completely destroyed.

C. H. Frazier et al., in 1937, reported the effects of irradiation on 30 gliomas studied exhaustively before and after treatment. In none was the tumor entirely destroyed.

Later in 1937, C. H. Frazier and B. J. Alpers published the combined experience of several American neurological clinics concerning the effects of irradiation on glioma. An investigation was made of 114 cases, but in no instance was the neoplasm totally abolished. By present-day standards the tumor doses were too low for many of the patients in these last two reports.

At Montefiore Hospital we have never observed, at post-mortem examination, complete destruction of gliomatous tumors following irradiation, although some patients received tumor doses in excess of 13,000 r in several courses with 200- to 400-kv irradiation.

For many gliomas it is well known that the mortality rate is highest during the first year after diagnosis has been made and following surgical intervention with or without postoperative irradiation. This being so, we cannot assume that the life period of the remaining patients has been extended by irradiation with increased dosage. It is possible that the patients surviving the first year have tumors of a less fulminating nature. The subsequent course, with control of symptoms by irradiation, may perhaps be achieved equally well for this group with conventional or supervoltage irradiation and with dosages that do not injure normal nervous tissue.

In glioma, changes simulating irradiation effects may occur without previous irradiation. Perhaps additional effects on the tumor result from blood-vessel alterations, for which intensive therapy is not necessary. It is also possible that clinical improvement results from growth restraint as much as from massive tumor destruction. This may explain the good response that in many instances followed conventional radiotherapy.

However, A. Arnold and others, in discussing 23-Mev betatron irradiation of brain tumors, state:

Histological studies made on tumor tissues obtained at repeated operations or at autopsies have shown that high energy X rays produce more intense changes in the tumor than has been observed in comparable tumors treated with conventional therapy. Some 40 autopsied cases of cerebral neoplasms that were treated with conventional X rays serve for histological comparison.

In particular, the cerebral glioblastoma multiforme, which shows only slight histological change to conventional X rays, shows a considerable degree of destruction to high energy X rays from the betatron.

This increased effectiveness of high-energy X rays appears to be due to the uniformity of tumor dose obtainable with high-energy rays and to the slightly greater intensity of dose administration employed in their first group of patients.

Dr. Arnold's results are interesting, although the number of patients treated is small. Time may well prove the betatron to be the best treatment for gliomas.

The results with Co^{60} beam therapy at Montefiore Hospital are not so good. Perhaps our daily and total doses are too low. We are now in the process of revising the dosage. We hope results will improve with more intense irradiation.

Every patient with a cerebral glioma in these three hospitals has gone into this experiment. They are allocated to four categories by random selection. There are patients who get the minimum surgery required to obtain a piece of tumor for observation,

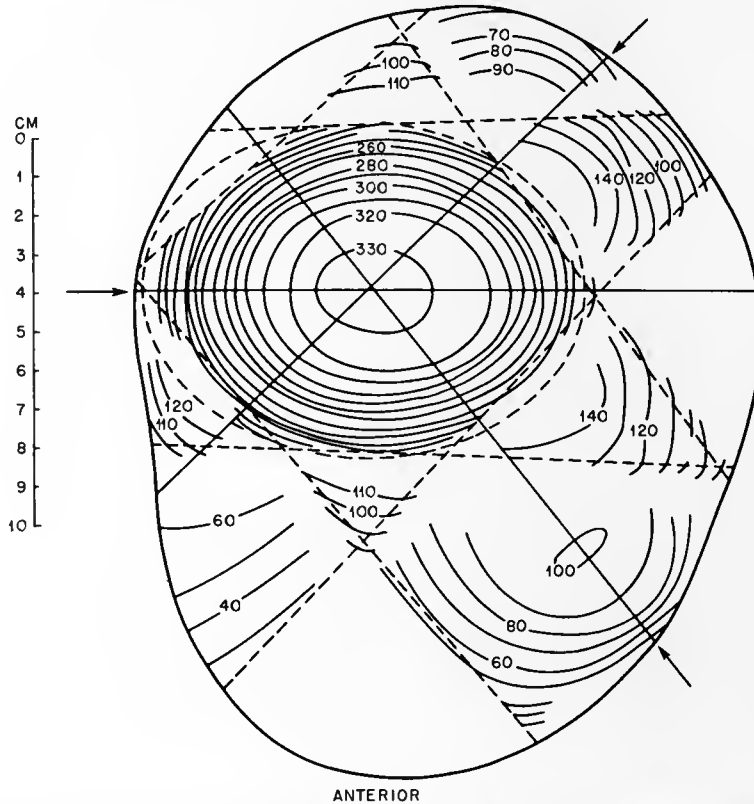

Fig. 3—Dose-distribution chart for a patient with cerebral astrocytoma, grade I, treated with 24-Mev synchrotron (8-cm circular fields).

Discussion

Smithers: I think that Dr. Freid's paper was full of good sense. It is true that there is no evidence yet available to anyone that either surgery or radiotherapy influences the course of the more malignant cerebral gliomas. There was a very interesting Medical Research Council Report in Great Britain three or four years ago, by J. J. Penman and Marion Smith, in which they reviewed the cases at the National Hospital, Queen Square, London; they found no difference in the life span of patients when treated surgically or by radiotherapy. We have now set up a clinical experiment with Dr. Penman in charge. I am not very much in favor of random allocation of patients to different methods of treatment because I usually like to do what I think is best for each individual; but, when a situation like this arises in which there is no evidence, I think this method of obtaining evidence is quite justified. This experiment has started with two neurosurgeons, Wylie McKissock and Valentine Logue, and three neurological hospitals.

nothing more being done for them; there are patients from whom the surgeon removes the maximum amount of tumor; and there are these two categories, each with radiation added. The sections go to three pathologists who see each section and report on them independently. The follow-up studies and the assessments are done by the neurologist, Dr. Penman, who is a real skeptic about any treatment method. We think that we should learn something from this method, which is now in its third year. Some 300 patients are already in this study.

One other small group might be of interest: our original group treated on the 24-Mev synchrotron. Figure 3 is a dose-distribution chart for a 33-year-old patient treated on the 24-Mev synchrotron, showing the kind of distribution that can be obtained by use of three fields, two in one plane and one in another plane, with a very highly concentrated tumor dose. For grades I and II glioma (one must have some philosophy about this), we tend to give a localized high-dose treatment. For grades III and IV, we tend to use a wide-field treatment because these tumors

THE BRAIN

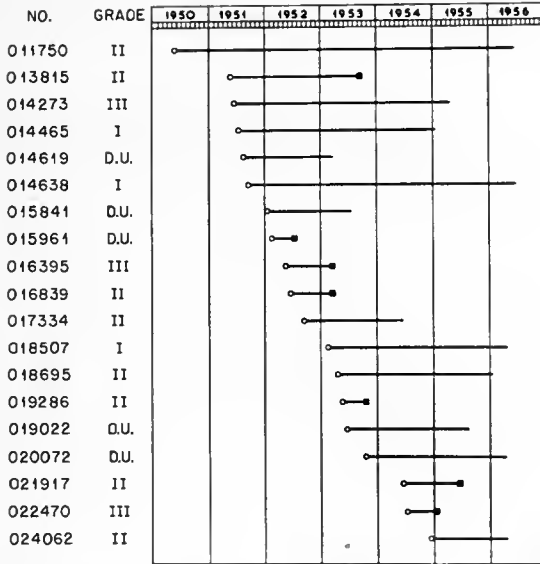

Fig. 4—Cerebral glioma patients treated with 24-Mev synchrotron at the Royal Marsden Hospital, 1950 to 1954. ○, time of treatment. ■, death



(a)



(b)

Fig. 5—Temporary epilation (a) and regrowth of hair (b) following a tumor dose of 7500 r to a cerebral glioma, grade I, treated with the 24-Mev synchrotron.

are so often diffuse. This represents a treatment for a grade I or II in the small group we have had.

In these small groups of patients from whose treatments we are trying to benefit in knowledge, we like the method (Fig. 4) of showing every patient on a chart. The hospital number appears so that anyone can look up the patient's history; thus the chart can be kept constantly up to date. It can be seen that, as

usual, the first patient treated by a new method is still living and well, from 1950 to 1956.

Perhaps one thing of interest about this treatment is that very large doses can be given without distressing aftereffects. The woman shown in Fig. 5 had a tumor dose of 7500 r in six weeks. She lost a bit of hair at the time (Fig. 5a), but it grew again, and, as may happen with radiation epilation, it grew back curly (Fig. 5b).

The Head and Neck

CHAPTER 46

Melville L. Jacobs

City of Hope Medical Center
Duarte, California

We have used our Co⁶⁰ teletherapy unit for one year. Our policy for cancer of the head and neck follows:

In the mouth, anteriorly, we prefer to let the surgeon take out the small lesions. This is effective and economical. We treat the larger lesions in the anterior portion of the floor of the mouth and on the anterior portion of the tongue with an intra-oral cone plus some form of interstitial radiation therapy, either radium needles or radon seed implants.

For lesions on the posterior portion of the tongue and in the posterior part of the mouth, we use cobalt beam therapy with fixed beams, usually two opposing portals. The tumor doses are between 5000 and 7000 r, usually delivered in 28 to 36 days. The group is too small and the time is too short to assess the procedure.

We have had a few lesions of the tonsil. One case in which the tumor involved both tonsils and hard palate was treated with two opposing portals.

One of the great values of supervoltage irradiation is that I am beginning to convince the surgeons that cancer of the larynx can be treated by irradiation. These lesions have been treated with two fixed opposing portals of approximately 4 by 5 or 5 by 5 cm. It has been easy to deliver doses of 5000 to 6500 r in 28 to 38 days. There has been very little skin reaction and no great discomfort to the patient.

The lesions in the nasopharynx have similarly been treated with fixed-beam portals: lympho-epithelioma with a tumor dose of approximately 6000 r and the lymphosarcomas, together with their neck metastases, with a tumor dose of approximately 3500 r.

I should like to tell about an experience with supervoltage radiation which is not known to many of you. At the California Institute of Technology in Pasadena in 1931, treatment of a series of cancer cases with one million volt X rays was begun. As far as I know, this was the first treatment with this modality in the United States.

About 800 cases were treated between 1931 and 1938; about 300 of these were cervix carcinomas, stage III

or IV. All were followed either to their death or for a period of at least eight years. The five-year salvage rate on the stage IV carcinomas was 12 per cent, a rather promising figure in those days. Remember that these were the days before antibiotics; and treatment with conventional voltage could promise nothing in patients with such extensive disease.

About 200 cases were carcinoma of the prostate, and the autopsies on these numbered close to 92 per cent. Only one patient had no residual carcinoma in the prostate at autopsy; in this case the pathologist was not certain that the patient had ever had carcinoma. These patients all received doses to the prostate of about 5000 to 7000 r.

A smaller group of carcinomas of the kidney had no favorable results.

A group of about 60 patients had carcinoma of the bladder, with not a single proven cure; there was residual carcinoma in every patient, either clinically or at autopsy. All these patients received tumor doses of about 5000 to 6000 r.

The late sequelae in many of these patients were severe. Dr. Friedman showed some that were quite characteristic of the changes that we observed. We were very much impressed with the extraordinary amount of damage done with one million volt X rays. Now that many more persons are going to use supervoltage irradiation, we should all remember that it is quite possible to do a great deal of damage with it.

Discussion

Friedman: In tumors of the head and neck, supervoltage radiation, especially with rotation, will find a field of great accomplishment—not usefulness, but accomplishment.

A number of patterns of treatment can be used. I shall describe one about which Dr. Smedal was asked but did not have the opportunity to discuss. It is that of encompassing with irradiation the primary tumor—say of a tonsil, together with the regional neck-node

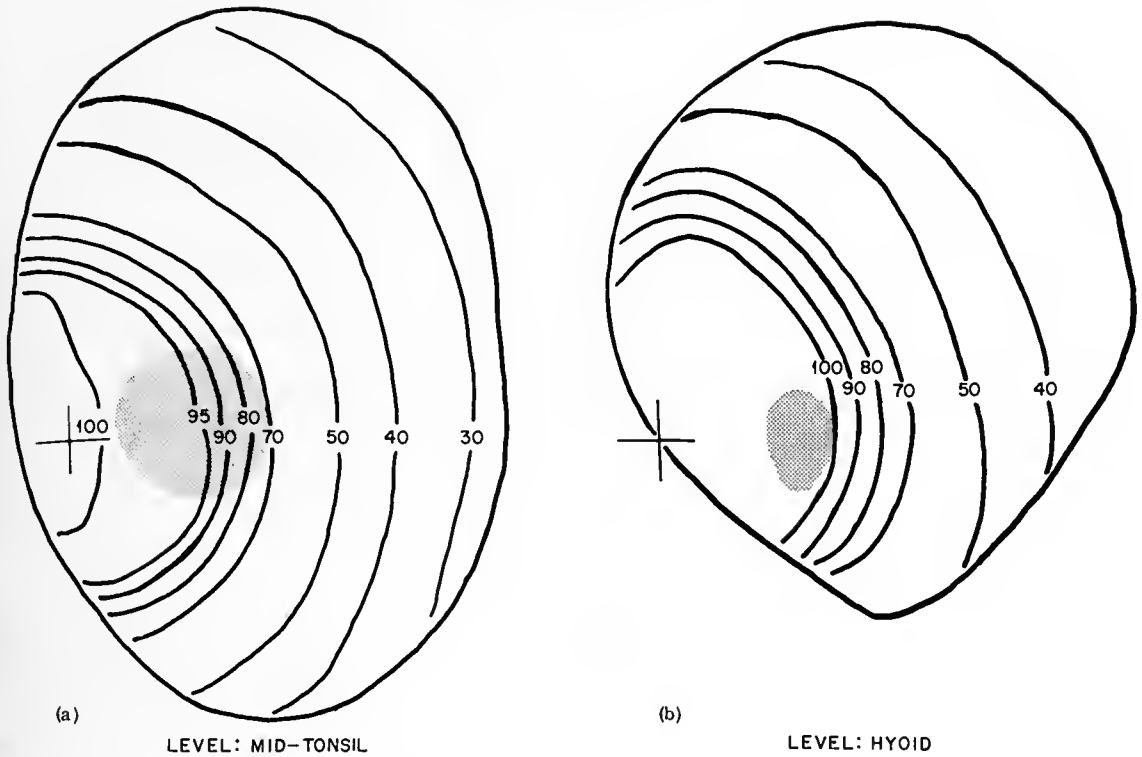

Fig. 1—Isodose curves of 2-Mv rotation irradiation of a carcinoma of the tonsil. (a) Cross section at level of mid-tonsil. (b) Cross section at level of the hyoid. (The shaded area represents the tumor, which is seen to extend into the hypopharynx. The cross indicates the axis of rotation. The portal width is 9 cm, and 360-deg rotation was used. At the level of the tonsil, three-fourths of the cylinder of intense irradiation lay in tissue, whereas in the neck-node area, only one-half was imbedded.)

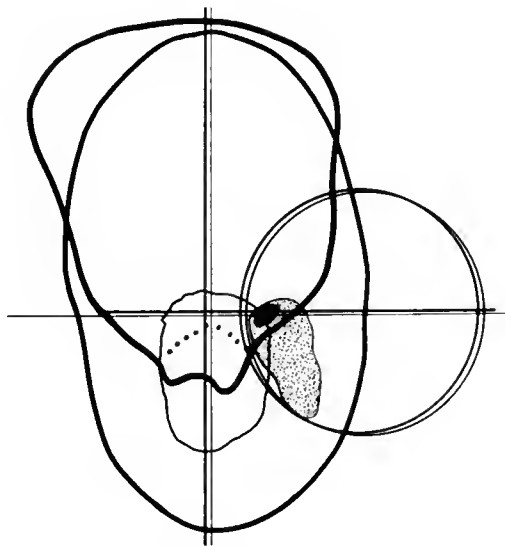

Fig. 2—Appearance of two superimposed contours during treatment planning for a patient with extensive carcinoma of the tonsil. The contour at the level of the tonsil shows the lesion (light-tone area) extending into the floor of the mouth and alveolar ridge. The contour at the hyoid level shows one metastatic node (dark area). The cylinder of intense irradiation has been positioned to encompass the primary tumor and lymph-node area in continuity. The portal was 8 cm wide, and 360-deg rotation was used.

area or neck nodes—within a single cylinder or hemicylinder of irradiation. This is similar to the principle of radical surgical extirpation of the tumor and nodes in continuity.

In carcinoma of the tonsil one can easily include the primary tumor and neck-node region in a hemicylinder and deliver doses of 9000 to 10,000 rads within five or seven weeks without too much discomfort to the patient, particularly since the epithelitis is unilateral.

As I have shown previously, this epithelitis is usually sharply confined to the region of high-intensity irradiation. For this purpose we have constructed a precision contour meter, which is rather necessary, and we make several contours with the patient fixed in position. One contour is made at the level of the primary tumor and another at the neck-node level (Fig. 1). Both contours are superimposed (the method is shown in Fig. 2), and the lesions are drawn in correct position. A hypothetical cylinder or hemicylinder of intensive irradiation is then drawn to encompass the primary tumor and the metastatic node regions.

Another type of lesion in which supervoltage is particularly useful is carcinoma of the nasal accessory sinuses. For carcinoma of the ethmoid sinus we do not use the rotation technique; but, with our ceiling-suspended tube, shifting the head and angle of the central axis of the beam, we can use multiple narrow portals in radial sagittal arrangement to build up a tremendously high intensity of radiation in the ethmoid, with very little side-scattered radiation reaching the eyeballs.

For the antrum it is a simple matter to deliver concentrated volumes of radiation without producing any external evidence of damage, and so far without internal late damage, with tumor doses of 8000 to 10,000 rads.

Another unique indication for supervoltage rotation in the head and neck is carcinoma of the nasopharynx, where it may make a decided contribution to the relief of this serious illness. For the primary tumor, supervoltage rotation is employed. Then the whole of both neck-node regions can be irradiated with tangential beams, while a central 4-cm slab is protected

with lead. With a setup of this type the dose to the nodes will range from 8000 rads on the surface to about 5500 rads in the depth.

With this technique one can irradiate the whole of both neck regions, producing only a slight dryness of the throat in the patients, provided the beam has a narrow penumbra, with very little scattered radiation going into the mucosa of the larynx and esophagus.

Carcinoma of the parotid, in our experience, is a radiocurable lesion if radical irradiation therapy is used. It can be arrested with single-portal massive-dose irradiation, using 250-kv X rays and delivering 7000 to 8000 rads skin dose in a minimum period of five to six weeks.

This type of radical irradiation can be given a little more comfortably through a grid and still more comfortably with supervoltage rotation. I do not yet know that any one technique is better than another, but I do know that radical irradiation therapy against carcinoma of the parotid can change the picture of these hitherto hopeless lesions into one with a fair number of arrests.

Lalanne: For the past year we have been treating, at the Institut Gustave Roussy, Villejuif (Seine), France, about 50 patients with lesions of the larynx, half intrinsic and half extrinsic. We used Co^{60} irradiation with oscillating rotation over arcs ranging from 140 to 220 deg. With this technique the tumor dose to the larynx was 6000 r, and to the nodes on both sides it was 3000 to 4000 r.

With a unilateral lesion this technique enabled us to deliver a higher dose on the affected side. We thought it better to use rotation therapy because it minimized skin reaction. There was no second-degree epidermitis with doses of 6000 r or even 7000 r. Previously, when using two opposing portals, we obtained some severe reactions.

We have no idea about the results, but our early observations indicate that the rate of disappearance of the tumor and the mucositis is about the same as that obtained with 250 kv. Perhaps the reaction appeared somewhat later. The weekly dose was 800 r.

The Lung

CHAPTER 47

James E. Lofstrom

Wayne State University College of Medicine
Detroit, Michigan

Abstract

This presentation is based on an analysis of 100 consecutive cases of bronchogenic carcinoma treated with Co^{60} teletherapy, with some comparative figures on experience within the same institution utilizing 250 kv with grid technique. Treatment planning and elements of dosimetry are presented, together with an analysis of palliation effects and survival. Major emphasis is directed toward palliation.

Introduction

For presentation of material on tumors of the lung, it is imperative that the ground rules under which this study was carried out be set forth.

First, it must be stated that this is a portion of an evaluation program. Specific dosage limits were prescribed as a result of joint consideration by a clinical committee. Our records have been maintained as formulated also by that committee. However, we did attempt to individualize treatment as much as possible under the general format of committee recommendations.

Second, and equally important, is the philosophy that guided our selection and handling of patients. We accepted for treatment practically every patient referred to us during this past two-year period in order to evaluate adequately the palliation efficacy as well as the survival rate. We therefore treated patients with known distant metastases for which some palliation might be accomplished without the risk of adding to their discomfort.

We have at Detroit Memorial Hospital one of the first low-specific-activity hectocurie units of about 340 rhm. We do not have variable field collimation or rotation, but we have a modest assortment of cones.

We are aware of the desirability of avoiding high dosage in critical normal structures such as the spinal cord. We are also cognizant of the degree of skin dose which was applied and that it exceeded the danger point as set forth by Dr. Friedman. We do feel, however, that there is a distinct difference in the cutaneous and

subcutaneous effect produced by Co^{60} irradiation compared with 1 Mv (11.1 mm of lead half-value layer as compared with 3.6). There is a significantly better situation existent with Co^{60} . In patients observed over a two-year period, we have encountered no significant cutaneous atrophy or subcutaneous fibrosis or other difficulty that might be attributed to a primary radiation effect, if there was not already disease present in the skin area.

Finally, since we put into operation the first Co^{60} or supervoltage unit in the Michigan area, we were forced to meet the challenge of an unusual influx of patients by using double shifts to meet this demand. Most of the terminal and near-terminal cases in the area gravitated to our doorstep during the initial phases of our treatment activity.

Clinical Data

Let us now review the clinical material to determine whether the philosophy was justifiable and what was accomplished. The general statistics of the material that was encountered during the approximately two-year period are given in Table 1. We recently completed our analysis after treating 100 patients. The general features, such as age, sex, and location of the lesion, correspond to the usual figures for bronchogenic carcinoma. The four unproved cases as to site were those in which the primary was of such minor consequence that its location was masked by other abnormality.

Dosage was 6000 r in five weeks to the center of the tumor in the first 15 cases. After this a more conservative program was undertaken; for the remaining 85 cases the dosage was decreased to 5000 r in five weeks.

There was pathologic confirmation in 88 cases; and, in spite of the seriousness and extent of the disease, of the total, 88 patients actually completed their treatment programs.

Table 2 enumerates the incidence of the signs and symptoms used to evaluate the palliative effect.

The surgical procedures on this group of patients are depicted in Table 3. What was gained by surgery is very difficult to say. Complete resection was accomplished in only 6 of the 44 operative cases; and it

Table 1—BRONCHOGENIC CARCINOMA TREATED WITH Co⁶⁰ TELETHERAPY*

Sex:	
Males	90
Females	10
Dosage:	
6000 r in five weeks	15 patients
5000 r in five weeks	85 patients
Average male age:	57.1 years
Average female age:	51.7 years
Average age:	56.9 years
Side of lesion:	
Right	58 patients
Left	48 patients
Unproved	4 patients

*One hundred patients treated from July 1954 through April 1956. Pathological confirmation of malignancy in 88 patients; completion of treatment program in 88 patients.

Table 2—FREQUENCY OF SYMPTOMS

Symptom	Incidence
Cough	53
Pain	24
Weight loss	20
Hemoptysis	17
Dyspnea	12
Weakness	10
None	6
Hoarseness	5
Pneumonia	4
Malaise	3

Table 3—SURGICAL PROCEDURES

Type of surgery	No. of patients
Exploration only	31
Incomplete resection	7
Complete resection*	6
Total	44

*It is doubtful whether the resection was complete because two of the patients had mediastinal metastases at the time of surgery.

is doubtful that it was complete inasmuch as two of the six had mediastinal metastases at the time of surgery. Incomplete resections were carried out in seven, leaving massive neoplasm in the mediastinum, often infiltrating the aorta, right auricle, and other vital structures such as the esophagus. Thirty-one patients underwent exploratory surgery. Thoracotomy is of definite value to the patient and also helps the radiotherapist to plan therapy better by providing more accurate knowledge of the histology and the exact extent of the tumor.

The survival data for the patients whose treatment was discontinued are summarized in Table 4. Treatment was discontinued as a result of extremely rapid growth in several of cerebral metastases, which we were unable to control. After one week's therapy for massive upper mediastinal metastases with caval obstruction, one patient died because of massive hemorrhage from an unsuspected gastric ulcer. The mass had

Table 4—SURVIVAL OF PATIENTS WHOSE TREATMENT WAS DISCONTINUED*

Survival after treatment:	1.9 months
Survival after diagnosis:	4.0 months
Survival after onset of symptoms:	5.1 months

*Data are determined from 12 cases: five anaplastic, two squamous, four undetermined, and one adeno.

begun to recede, and the patient was showing general improvement before his death. The gastric ulcer was seen at autopsy, although there had been no prior clinical evidence. We have found a remarkable incidence of 14 peptic ulcers in our series of 100 cases of bronchogenic carcinoma, which is well beyond the usual incidence. We have not investigated all of them roentgenographically. In several patients the nausea of radiation sickness seemed to be out of proportion for the therapy given, and on gastrointestinal examination ulcer was discovered.

Treatment Planning

It is essential that consideration be given to the morbid anatomy of bronchogenic carcinoma in a determination of the fields to be employed. Inasmuch as most of the primary lesions occur within the central or root zone of the lung and the contiguous extension is into the adjacent hilar and paratracheal lymph nodes, this most critical area can usually be encompassed in a reasonable-size field. The most common extension beyond this point is into the adjacent portion of the mediastinum superiorly. Next in frequency is usually the extension of the disease inferiorly in the mediastinum. Individual metastatic masses then appear in the upper mediastinum and later in the supraclavicular area. Finally, there are distant metastases to the brain, pancreas, bone, and other sites. The problem is to incorporate the extensive disease into treatment areas without danger of overlap and with an associated attempt to minimize integral dose.

Whenever possible, we attempted to include within the primary treatment field the primary site and the regional extension of the tumor. In some sthenic chests it is possible to encompass the superior mediastinal area within this same treatment field. In most patients, however, additional fields had to be employed to cover the upper mediastinal area. A common type of involvement is depicted in Fig. 1. The primary tumor was in the right middle lobe, and massive mediastinal metastases extended to the thoracic inlet. The lined area represents the coverage obtained with a 12- by 15-cm field. The chief complaint of this patient was difficulty

in swallowing, and there was no significant pulmonary symptomatology. The lateral view (Fig. 2) again indicates the problem of field placement in order to include the middle-lobe area, the massive metastases in the central area of the mediastinum, and the high superior and posterior mediastinal involvement. There was considerable pressure on the esophagus at the latter level, although this is not well demonstrated on the reproduction.

We have used two opposing ports in a great many of our patients, including as little of the spinal cord as possible. Since the disease in its extended state is essentially mid-line, the problem is very similar to that encountered in therapy of the esophagus; the former has a wider distribution of the malignancy, and a greater volume of tissue must be homogeneously treated.

The treatment plan was modified whenever indicated by the employment of one anterior and two posterior oblique fields or one posterior and two anterior oblique fields. If the disease process was laterally situated, we added a lateral field. Additional fields were then added as necessary for the upper mediastinum and supraclavicular areas.

Beam-aiming was corroborated by fluoroscopy and radiography in the treatment position. Our treatment cones can be fitted into the base of a radiographic tube support, giving the same relative geometry as that obtained with the cobalt-therapy head. The technical quality of the films is better than that obtained with supervoltage X rays.

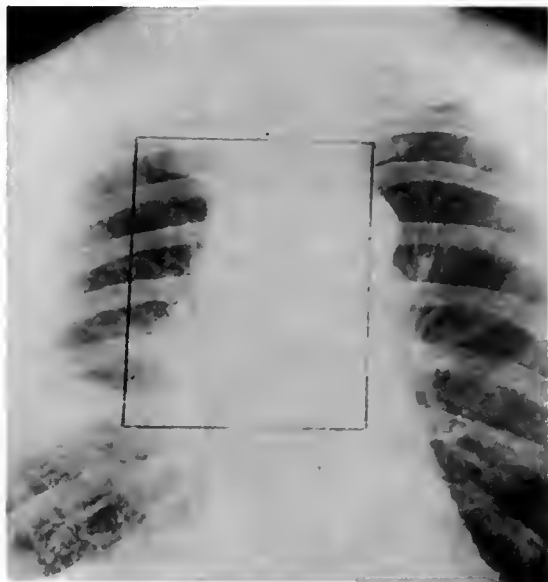

Fig. 1—Coverage (lined area) obtained with a 12- by 15-cm field for a tumor in right middle lobe, with massive mediastinal metastases extending to the thoracic inlet.

The tumor dose was 6000 r in five weeks for the first 15 cases and 5000 r in five weeks for the remainder. This tumor dosage delivered at a given point is not absolute for the entire mass. It has been deter-

mined that there is a variation from 100 per cent at the center to 118 per cent at the periphery. There is also an added amount for the increased transmissibility of the aerated lung. No compensation was made for this unless a lateral field was employed and the beam traversed a hyperventilated lung. In the case of an anterior and posterior portal, the tumor dose was calculated at the mediastinum. Therefore the portion of the tumor extending into the aerated lung might have received dosages that ranged from 5750 r to, perhaps, 7000 r.

Supplemental medical therapy was given many times. Nitrogen mustard was employed preirradiation in the anaplastic tumors. Chromic phosphate ($\text{CrP}^{32}\text{O}_4$) was used in the pleural cavity for effusions. Cortisone was not used in the early stages of treatment but was used only for symptomatic therapy after a possibility of fibrosis and pneumonitis.



Fig. 2—Lateral view of tumor in Fig. 1, indicating again the problem of field placement to include the middle-lobe area, the massive mediastinal metastases, and the high superior and posterior mediastinal involvement.

Results

Table 5 gives the number of cases, distribution according to histologic character, average age of patient, and survival data. The survival time is given in months following initial treatment, establishment of diagnosis, and onset of symptoms. The over-all survival time for all cases, including the incomplete ones, is 6.8 months following initial treatment. When these figures are corrected by the elimination of the incomplete cases, there is only slight improvement to an average of 7.5 months. These figures are extremely familiar. They are nearly the same as those that have been reported following various surgical procedures. We therefore must recognize that little is accomplished as far as the over-all pattern of survival is concerned.

SPECIAL TECHNIQUES FOR SPECIAL TUMORS

Table 5—SURVIVAL DATA FOR 100 PATIENTS TREATED FOR BRONCHOGENIC CARCINOMA WITH Co⁶⁰ TELETHERAPY

Type of tumor	No. of patients	Average age	Survival time,* months		
			After treatment	After diagnosis	After onset of symptoms
Anaplastic	34	54.3	5.5 (6.2)	6.6 (7.7)	10.3 (11.9)
Squamous	36	54.9	7.3 (7.7)	9.8 (9.9)	12.3 (12.5)
Adeno	10	54.3	9.4	14.3	12.3
Undetermined	20	61.0	7.0 (8.3)	8.7 (10.2)	14.5 (16.5)
Average		56.9	6.8 (7.5)	9.6 (10.4)	12.9 (13.9)

*Figures in parentheses are corrected by elimination of the incomplete cases.

Miscellaneous survival data are as follows:

Palliative resections:

12 patients: survival of 9 months after Co⁶⁰ therapy

Survival of more than 7 months:

46 patients: average survival of 11 months after treatment

24 (52 per cent) patients: palliated

Survival of 1 year or more:

19 patients

9 (47 per cent) patients: palliated

It is noted that where palliative resection has been carried out the patients have fared a little better in over-all survival than in the general average. This improvement factor is 9 months, as compared with 6.8. Of 46 patients in the total group who lived longer than 7 months after therapy, continued improvement was also demonstrated with average survival of 11 months following therapy. Also indicated is the fact that 24 of this group of 46 patients received what was determined as palliation. Percentagewise this is impressive in that it represents 52 per cent. This compares favorably with the experience in 19 of the patients who lived more than one year and in which group nine (47 per cent) received good palliation.

How was palliation judged? If the patients did not have significant pain or other remarkable symptomatology and if they followed a continuous asymptomatic course, they were not included in the palliated group. Obviously, specific evaluation could not be made with

reference to symptomatology and palliation on the basis of what might have happened later. Palliation in this study is based strictly on the relief of symptoms or the improvement in the general condition of the patient. Of the 34 patients in the total group who were considered palliated (Table 6), there is a slight improvement in the over-all survival time (9.2 as compared to 6.8 months). In general, those who seemed to

Table 6—PALLIATION IN 34 PATIENTS*

Type of tumor	No. of patients	Patients palliated	
		No.	Percentage
Anaplastic	34	12	35
Squamous	36	11	30
Adeno	10	3	30
Undetermined	20	8	40
Total	100	34	

*Survival after therapy, 9.2 months; after diagnosis, 11.8 months; after onset of symptoms, 15.4. The average age of the patients was 56.5.

get better response from therapy lived somewhat longer than those who did not. Palliation was quite good (35 per cent) in the anaplastic group. In this group were a great many patients who had extensive disease and frequently remote metastases. This palliation value is equivalent to that obtained in averaging the entire group of cases.

An attempt was made to evaluate palliation in relation to the tumor, as demonstrated radiographically

Table 7—LESIONS VISIBLE ON X RAY IN 71 PATIENTS WHO COMPLETED THERAPY

X-ray response	Type of tumor								Total*
	Anaplastic		Squamous		Adeno		Undetermined		
	Pall.	Unpall.	Pall.	Unpall.	Pall.	Unpall.	Pall.	Unpall.	
None	0	5	1	8	1	2	2	1	20 (4, 16)
Minimal	6	1	3	1	0	1	1	2	15 (10, 5)
Moderate	1	2	4	2	2	0	3	3	17 (10, 7)
Marked	5	6	0	4	0	1	2	1	19 (7, 12)
Total	12	14	8	15	3	4	8	7	71 (31, 40)
Fibrosis	8	2	5	3	2	1	7	3	31 (22, 9)

*For the figures in parentheses, the first number represents the total given palliative therapy, and the second number represents the total given unpalliative therapy.

(Table 7). The various histologic types of lesions are listed with the degree of objective response as determined by serial radiographs. There is no relation between radiographic response and palliation. Only 71 patients could be analyzed in this manner because there were many instances where the lesions were masked as the result of surgical procedures and overlying pleural densities. Also indicated in Table 7 is the frequency of pulmonary fibrosis in this series; it is high, and serious consideration must be given to this. Only a few other complications were noteworthy. Very little radiation sickness was encountered.

An analysis was made of 15 patients who developed radiation reactions (Table 8). This study was an attempt to determine whether there was any correlation

Table 8—RADIATION REACTIONS IN 15 PATIENTS*

Type of tumor	No. of patients	Dosage of 6000 r in 5 weeks	Palliation	Fibrosis
Anaplastic	7	3	3	2
Squamous	5	2	3	1
Undetermined	3	1	0	2
Total	15	6	6	5

*Average survival after treatment was 8.8 months. Response of tumor was marked in four, minimal in four, and nonexistent in seven of the patients.

between such sickness and objective evidence of tumor response, and also whether there was any correlation with over-all palliation and ultimate development of parenchymal fibrosis. Of interest is the high incidence of radiation reactions in the group of patients treated with a dosage of 6000 r in five weeks. No significant correlation can be established between the other elements, such as tumor response, palliation, and fibrosis. The average survival time of 8.8 months is only slightly better than the experience with the entire group (6.8 months).

Table 9—TUMOR DISTRIBUTION IN 46 PATIENTS TREATED WITH 200 KV AND GRID TECHNIQUES*

Type of tumor	No. of patients
Squamous	20
Anaplastic	11
Adeno	5
Undetermined	10

*Palliation resulted in 21 cases (46 per cent).

Concerning other complications, there were none in the cutaneous structures, heart, or spinal cord. Routine electrocardiograms were made in about one-third of the patients before, during, and after therapy, and no demonstrable electrocardiographic change could be detected in spite of the massive dosage administered over the area of the heart. Esophagitis was a complication in a few patients; but it was transitory, and they recovered without difficulty.

We do not have sufficient autopsy material analyzed critically at this time to be of particular significance. We did, however, accomplish a sterilization of the primary area of the neoplasm in several instances, but in each of these the metastases were not eradicated.

Table 10—AVERAGE SURVIVAL OF 46 PATIENTS TREATED WITH 200 KV AND GRID TECHNIQUES

Survival after treatment:	6.4 months*
Survival after diagnosis:	8.8 months
Survival after onset of symptoms:	12.8 months

*Excluding seven patients who had incomplete therapy improves survival after treatment from 6.4 months to only 6.6 months.

For comparison of results, data are presented in Tables 9 and 10 in an analysis of 46 patients treated with 200 kv or 250 kv, utilizing grid techniques. These patients were seen during the same interval as those in the cobalt series. The distribution according to cell type is similar. Palliation (46 per cent) and survival following therapy (6.4 months) are nearly identical with the data encountered for the Co⁶⁰ series.

Conclusions

1. We have not significantly extended the life span of patients with bronchogenic carcinoma by utilizing supervoltage irradiation as compared with conventional modalities, which include 250-kv roentgen therapy and also the contributions of surgery.

2. Cobalt teletherapy is, as has been stated previously by others, easier to administer to the patient than is 250-kv therapy.

3. Dosage can be administered usually in a shorter interval of time. (The dosage in the 200- to 250-kv group was 4200 to 4800 r tumor dose in a period of 10 weeks.)

4. There was much less local and general discomfort to the patient with supervoltage irradiation.

5. Irradiation complications have been inconsequential. The most difficult problem has been radiation pneumonitis. There have been no significant signs of skin damage or spinal cord or cardiac complications.

6. As a result of a relative increase in life span, more extensive remote metastases are commonplace.

7. Isolated clinically significant metastatic areas can be treated advantageously and should be vigorously irradiated in a great many instances.

8. Supplemental medical therapy is of occasional assistance. Nitrogen mustard, chromic phosphate (CrP³²O₄), and supplemental endocrine therapy may be of assistance to the patient.

9. Treatment of bronchogenic carcinoma with cobalt teletherapy should be pursued with diligence and with more critical attention to specific areas and specific dosage.

10. There is no critical level of dosage as far as we have been able to determine. There is no magic number of roentgens or rads: the mystical number is still in the category of riddles.

Discussion

Freid: Dr. Lofstrom, your paper is of special interest to me because I am going to report, at the Eighth International Congress of Radiology to be held in Mexico City, on 110 patients with carcinoma of the lung, most of them inoperable, who were treated with Co⁶⁰ beam therapy. Of these, 100 had histological verification. Twenty are alive and noticeably improved, 6 to 36 months after irradiation; 42 were improved for 6 to 24 months but then died; 42 responded poorly and died within 6 months; 12 of 16 patients with pleural effusions reacted poorly and died within 6 months. Four patients had carcinoma in an area containing a tuberculous lesion. They were treated without exacerbation of their acid-fast disease but responded poorly to irradiation. The type of tumor played an important role in longevity. Of 46 patients with anaplastic carcinoma, only four (8 per cent) lived more than one year; of those with squamous-cell carcinoma, nine (27 per cent); and, of those with adenocarcinoma, two (22 per cent).

I hope others here will comment on their experiences in treating carcinoma of the lung arising in

areas with active or inactive tuberculosis and on the results in patients who have pleural effusions.

Ellis: We had a patient with tuberculosis, and it was arranged with the chest physicians that he be covered with chemotherapy while we treated him. We carried on with the treatment, feeling quite assured. When we had finished, we discovered that he had had no chemotherapeutic cover at all. The physicians had not noticed any untoward effect.

Freid: Did he have positive sputum?

Ellis: Positive sputum. The only thing I would say is that I do not think Dr. Lofstrom is going to achieve anything by increasing the dose. We feel, using what we call "conventional therapy," that we get just as good results, if not better, with doses of 3000 to 3500 r to the tumor as with 4000 to 4500 r.

Smedal: We consider pleural effusion, unless it is postoperative, to be a contraindication to therapy because it is a distant spread, unless X ray is given as a purely palliative procedure. I think cells might be found in the pleural exudate, and the pleura would show implants.

PART

DISCUSSION OF CASE PROBLEMS

4

Section

J

Clinic on Stationary Fields

David S. Carroll
(presiding)

Carcinoma of the Tongue, Case Report

CHAPTER 48

David S. Carroll

University of Tennessee College of Medicine
Memphis, Tennessee

When we saw all the wonderful equipment here at the Oak Ridge Institute of Nuclear Studies, I could not help thinking what a pity it is that a larger percentage of our tumors are not properly impressed with such impressive equipment.

I shall describe the case of a 78-year-old Negro man who was treated by Co^{60} teletherapy for squamous-cell carcinoma of the tongue in the fall of 1954.

The patient first noted a small mass in the right lateral border of the middle third of the tongue in August 1953. It did not become painful until November, and the patient finally went to the West Tennessee Cancer Clinic in December 1953. Examination revealed a hard mass measuring 1.5 by 3 cm, which involved the right lateral portion of the middle third of the tongue. There was a small, shallow ulceration in the middle of the tumor. The regional lymphatic areas revealed no metastasis. The teeth had all been extracted many years before. Although the blood serological test for syphilis was positive, he had had adequate treatment, and there was nothing in the history to indicate that an oral luetic lesion had ever been present.

The biopsy specimen showed a rather well differentiated squamous-cell carcinoma. The patient refused surgery and deferred treatment for 10 months. He came to me in October 1954.

On examination the tumor was now quite extensive; it reached from the tip of the tongue back into the posterior third, involved the entire right half, and extended across the mid-line. There was an extremely tender, infected, deep ulcer in the middle of the tumor. There was still no lymph-node metastasis. The patient was emaciated, having lost 30 lb.

Treatment with Co^{60} gamma radiation was begun Oct. 20, 1954, and completed Nov. 24, 1954. The floor-mounted stationary hectocurie teletherapy unit was used. The source was 302 curies of Co^{60} in a standard capsule; the source-to-skin distance was 35 cm; and the roentgen flux was 47.1 r/min. Two opposing portals were used, each measuring 6 by 7.5 cm at the surface.

The center of the tumor was 4 cm from the surface of the right lateral portal and 5 cm from the surface of the left lateral portal.

An air-exposure dose of 4410 r to each portal gave a surface-exposure dose, entrance plus exit, of 6400 r and a central tumor dose of 6000 r, delivered in 20 treatments over an elapsed time of 34 days. The integral dose was 2.94 Mg-r.

The irradiation was well tolerated. Mucositis was first noticed at the end of one week and progressed to a severe degree by the end of therapy. The only skin reaction was epilation. There was no erythema.

The tumor steadily regressed in size; by the end of treatment the ulcer had healed, and no residual tumor could be seen or felt. Six weeks after completion of therapy, mucositis had practically subsided. The patient gained 30 lb weight. The only complaint was the dry mouth and loss of taste. By the end of the fifth month, the sense of taste had returned, and the patient no longer noticed any dryness of the mouth. At the present time, 20 months after completion of therapy, there is no evidence of residual disease, and the patient continues to feel well. There is no atrophy of the skin and no change in skin pigmentation. The only abnormal finding at this time is epilation within the irradiated fields.

During the past two years we have treated with Co^{60} teletherapy eight patients having carcinoma of the tongue. Of these, three have been followed for 18 months or longer, with no evidence of residual disease. Two had no residual disease at the end of therapy but were lost to follow-up studies. One had no residual disease in the tongue, but the cervical nodes did not completely regress. He died of brain metastases two months after completion of therapy. One has had no disease in the tongue for 22 months after completion of therapy; but his large bilateral cervical-node metastases never completely regressed. One patient had a lesion of the tongue which did not respond to radiation therapy at all and which was resected four months later. It is interesting to note that, although

seven of the eight patients had prompt and apparently complete regression of the primary tumor, the lymph-node metastases have been more resistant and have not responded so well.

Several speculations and conclusions can be made.

1. Skin damage is seldom of any consequence at ordinary dose levels, such as those used in the patient discussed. The outstanding exception to this is the obese patient treated over pressure-bearing areas, where fat necrosis can be a very distressing complication.

2. The incidence of bone necrosis will probably be considerably less than that with conventional X ray because of the lower energy absorption. So far we have not encountered a single case of bone necrosis; however, we have not used the teletherapy unit long enough for this clinical observation to have much significance.

3. We have not been able—and I am sure I shall get a lot of argument with this—to detect a real significant

difference in the normal soft-tissue radiation reaction at a depth or in the degree of tumor response for comparable calculated doses of gamma radiation from Co^{60} and conventional X ray. Any accurate estimation of the difference in biological effect will probably have to await comparable long-term statistics on a significant number of patients.

4. The increased depth dose of Co^{60} gamma radiation, particularly with small portals, has been helpful in clinical therapy.

Finally, there seems to be little reason to use rotational techniques in the treatment of lesions about the oral cavity and pharynx, provided one is satisfied with dosage such as was used in the patient discussed here. Furthermore, the geometrical distributions of many tumors in this region do not lend themselves well to rotational techniques.

Treatment of Carcinoma of the Cervix with Co⁶⁰ Teletherapy

CHAPTER 49

Irvin F. Hummon

Cook County Hospital
Chicago, Illinois

We have had an Eldorado type A Co⁶⁰ beam-therapy unit three years. At present we have a new source of 2400 curies, giving 45 r/min at 1 meter.

This machine has a mercury shutter, which has given no trouble. The emergency method of shutting it off is simple, and on trial runs we found that it works satisfactorily.

This unit has only two motions: (1) up and down and (2) a circular motion around a horizontal axis. Even with this limited motion it is amply flexible. To obviate possible injury due to the sharp points of the cone and the backpointer, we have replaced them with flexible coil springs, which will move out of the way and will not injure the patient.

One thing all units should have is a separate device for indicating that the machine is on. It would be very simple to do this by putting a small ionization chamber or calcium sulfide crystal in the port. We have solved this by placing a small G-M tube in a receptacle in the floor and connecting it with a separate rate meter. This indicates when the machine is on and off. Servicing requirements have been minimal.

The usual cancer patient is debilitated and has lost weight. However, in the early stages of cancer the patient is often obese. The incidence of cancer in the obese is high. In the past year we have had 26 patients with carcinoma of the cervix in which the anteroposterior diameter was more than 28 cm. Some were more than 40 cm and weighed up to 350 lb. With an ordinary X-ray machine one would be just about as lost as when trying to do a bimanual examination on these patients.

The patient to be reported had a carcinoma of the cervix and an anteroposterior diameter of 30 cm. The plan was to combine radium with X-ray treatment, using two anterior and two posterior fields, each 12 by 15 cm, leaving the mid-line untreated. The percentage depth dose at 15 cm with cobalt (and an 80-cm source-to-skin distance) is 42 per cent. The exit

dose at 30 cm is 20 per cent. Compare that with X rays with 2 mm of copper half-value layer whose depth dose is only 12 per cent at 15 cm. In using Co⁶⁰, a supplemental parametrial tissue dose of 3500 r requires 4200 r skin dose to each of two opposing ports per parametrium. This can be given in daily doses of 420 r to one port per day for four weeks. Skin reaction is minimal, and systemic reactions are usually absent.

The following figures illustrate a large ring source. We obtained 30 aluminum tubes from Dr. Brucer, each 1 in. in diameter and about 8 in. long, containing 100 microcuries of Cs¹³⁷ adsorbed to resin. We placed these in a circle 2 meters in diameter (Fig. 1). For some of our calibrations we used a water phantom. Most measurements were made with a small G-M tube.

Figure 2 shows the dose distribution about such a ring source with nothing inside the ring. In the first portion at the center, the distribution is rather uniform. As one moves toward the source, the distribution soars, and then it declines as one goes beyond the source.

Figure 3 shows a modification using radial fins of lead. They have the property of permitting the center to receive radiation from all parts of the source. The periphery of the phantom received only a portion of the radiation.

Figure 4 shows such a distribution in a phantom with 15 radial fins. The dotted line indicates the edge of the phantom. Compared to the center, the edge receives about 50 per cent. The rest of the curve is similar to that in Fig. 2.

Figure 5 shows the distribution close to the center of the source under various conditions as indicated by the legend.

Here there is, at least theoretically, a means of using a stationary-field technique and getting rotational-therapy results.

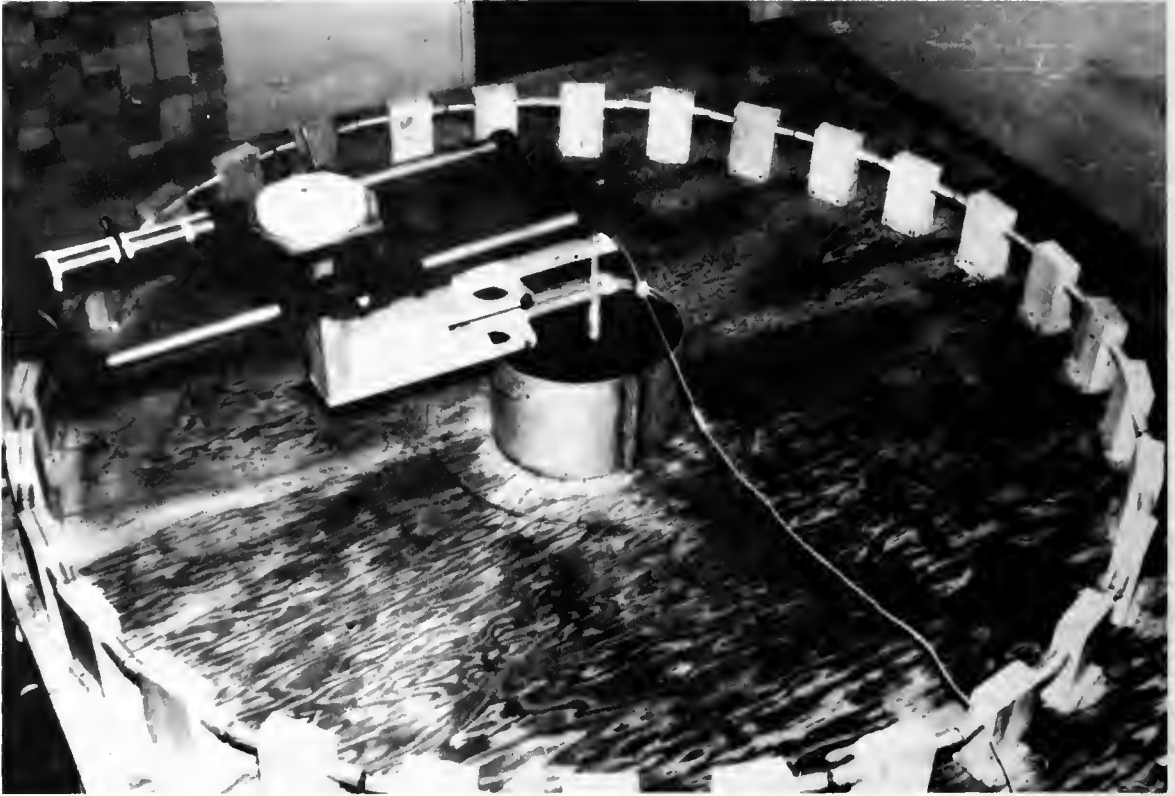

Fig. 1—Two-meter ring source with water phantom and a G-M probe.

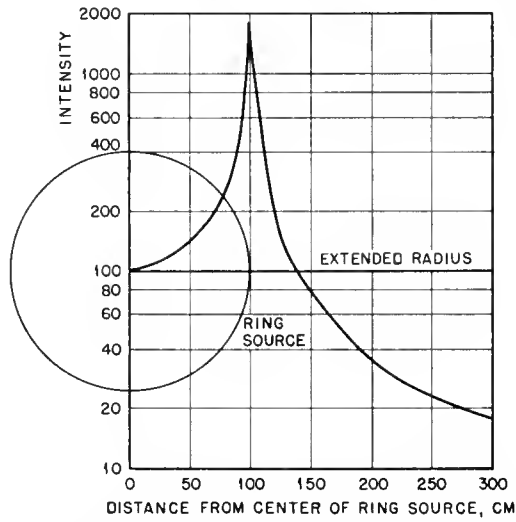

Fig. 2—Dose distribution along one extended radius, within and outside the 2-meter ring source (no phantom, fins, or barriers).

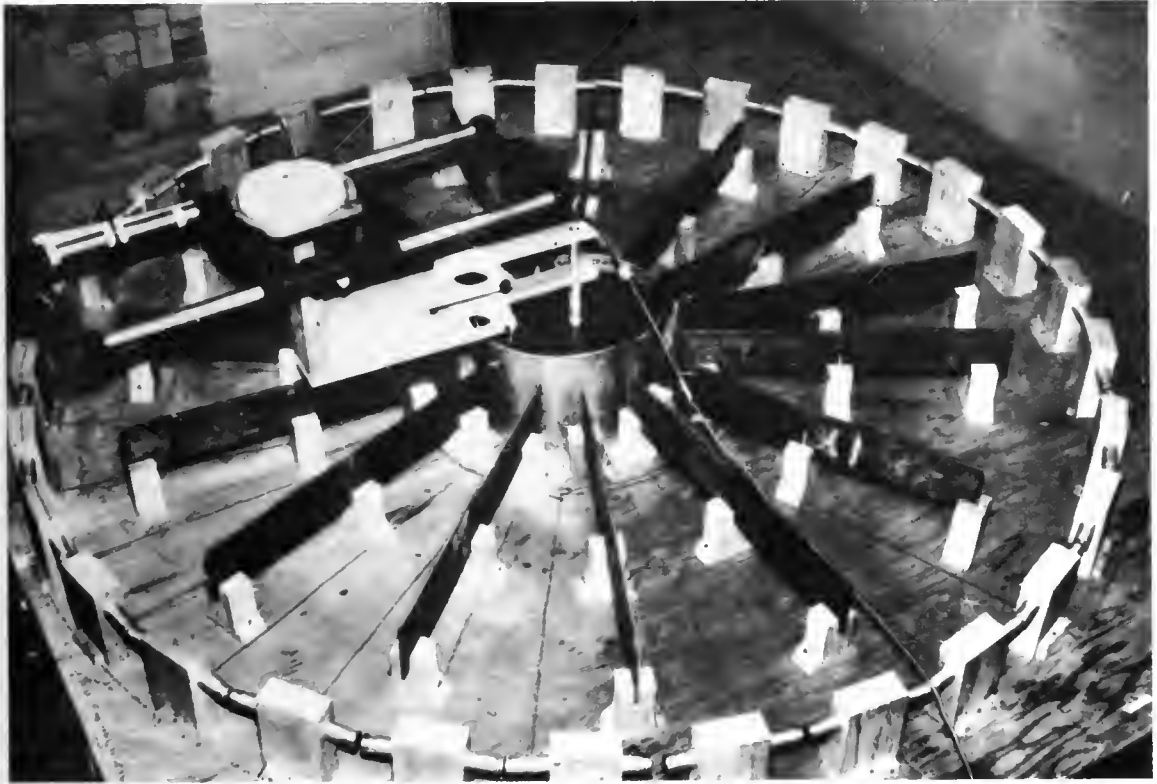

Fig. 3—Ring source, showing radial fins and phantom.

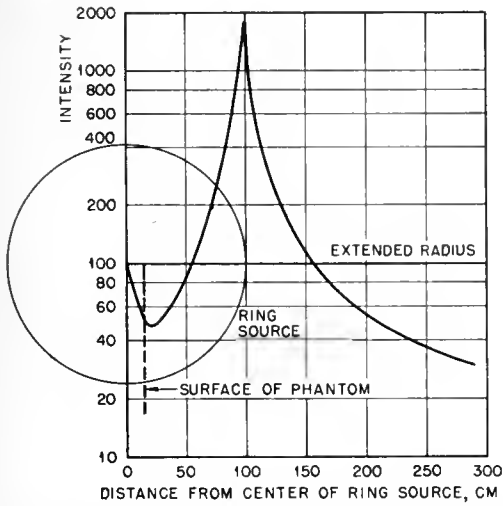

Fig. 4—Dose distribution along one extended radius, with a 30- by 40-cm elliptical water phantom and 15 radial lead fins (10 by 60 by 0.6 cm).

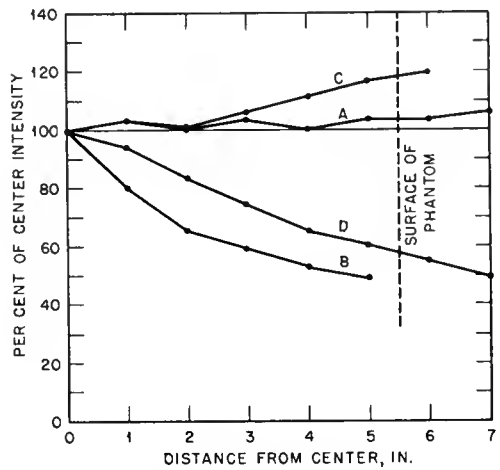

Fig. 5—Dose distribution within 6 in. of the center of the source. A, no fins or phantom; B, 15 fins but no phantom; C, phantom but no fins; D, phantom and 15 fins.

Carcinoma of the Lung, Illustrating Avoidance of Spinal Cord with Co^{60} Teletherapy

CHAPTER 50

Norman Simon

Mt. Sinai Hospital
New York, New York

This case of carcinoma of the lung is presented to show that Co^{60} radiation allows the administration of 6000 rads to the tumor through two opposing anterior and posterior fields; however, this method is unwise because of the danger of overirradiating the spinal cord. Therefore multiple portals are used. Beam direction is aided by films made with the cobalt source in treatment position.

During the two years we have been using our Kelek-Barnes Co^{60} hectocurie teletherapy unit, we have treated 375 patients, 43 of whom had carcinoma of the lung. It seems unlikely that the number of five-year survivals in carcinoma of the lung will be dramatically, or even appreciably, increased by cobalt irradiation. Yet the general advantages of cobalt teletherapy, including the sparing of skin, the increase in depth dose, and the decrease in bone absorption, make this type of teletherapy useful in the treatment of carcinoma of the lung and make it superior to conventional (200 kv) X-ray therapy.

Treatment plans with cobalt teletherapy are simple, and two opposing fields can provide depth doses in the cancerocidal range. However, this tissue dose may be so high that the intervening innocent and sensitive tissues may be irradiated beyond their tolerance. The possibility of radiation transverse myelitis must be avoided.

For treatment over the spine with 200-kv X rays, the skin reaction provides a safeguard against overdosage to the spinal cord. With cobalt teletherapy the skin shows so little reaction, even with an exposure dose of 7000 r, that the tolerance of the spinal cord may be easily exceeded.

The danger of treating lung cancer near the hilum with two opposing anterior and posterior fields has been pointed out by A. M. Evans and his group from the British Columbia Cancer Institute (Canada). In a report of April 1954, they indicate that a myelitis occurred with a dose to the cord of 5000 r in 35 days.

Even with Co^{60} teletherapy it is wise to treat central

carcinomas of the lung with multiple portals, and perhaps it is even wiser to use rotation.

However, a simple modification using three fields for the treatment of medial carcinomas of the lung makes a satisfactory compromise with the ideal.

A patient who illustrates such a treatment plan is a 60-year-old housewife who had active pulmonary tuberculosis for one year before her treatment for cancer of the lung.

In January 1954, the patient complained of a slight cough, and fluoroscopic examination showed a calcified nodule in the upper lobe of the right lung. Cultures of the sputum repeatedly showed tubercle bacilli, and the patient was treated with antitubercular drugs. Bronchoscopy was negative at the onset of this disease.

In December 1954, one year later, the cough increased despite the fact that the sputum had become free from acid-fast bacilli. A radiograph (Fig. 1) of the chest showed a new streaky infiltration of the upper pole of the right hilum. A bronchoscopic biopsy from the right-upper-lobe bronchus revealed anaplastic squamous-cell carcinoma.

At operation in January 1955, the tumor was found unresectable because of large involved nodes in the right hilum and in the right superior mediastinum alongside the trachea.

With Co^{60} teletherapy a dose of more than 6000 rads was delivered to the tumor in six weeks through three portals, opposing anterior and posterior right hilar fields and a right posterior oblique field (Fig. 2). By administering an exposure dose of 4200 r (in air) to each field (7.5 cm square) with a source-to-skin distance of 35 cm, the tumor dose of more than 6000 rads in six weeks was reached with no discomfort to the patient. Treatments were given daily (five times a week) from Feb. 7 to Mar. 25, 1955.

About one month after completion of therapy, the cough abated, and it has not recurred. The patient has no clinical evidence of cancer, 15 months after treatment. A recent X-ray film of the chest showed fi-



Fig. 1—Radiograph before cobalt teletherapy for anaplastic squamous-cell carcinoma involving right-upper-lobe bronchus and paratracheal nodes.

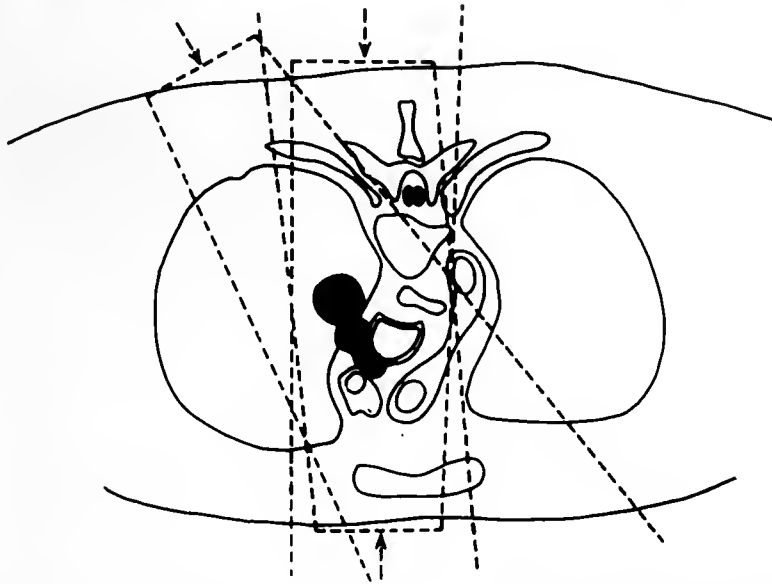

Fig. 2—Treatment plan for tumor of the right hilum of the lung. A right posterior oblique field has been added to spare the spinal cord while increasing the dose to the tumor. Each field received 4200 r, and the tumor received 6000 rads.



Fig. 3—Radiograph of the same patient diagramed in Fig. 2, 15 months after cobalt treatment. The streaky infiltration of the upper pole of the right hilum is due to radiation fibrosis. The densities in the right costophrenic angle are due to the combination of postoperative pleuritic reaction and radiation pleuropulmonitis.

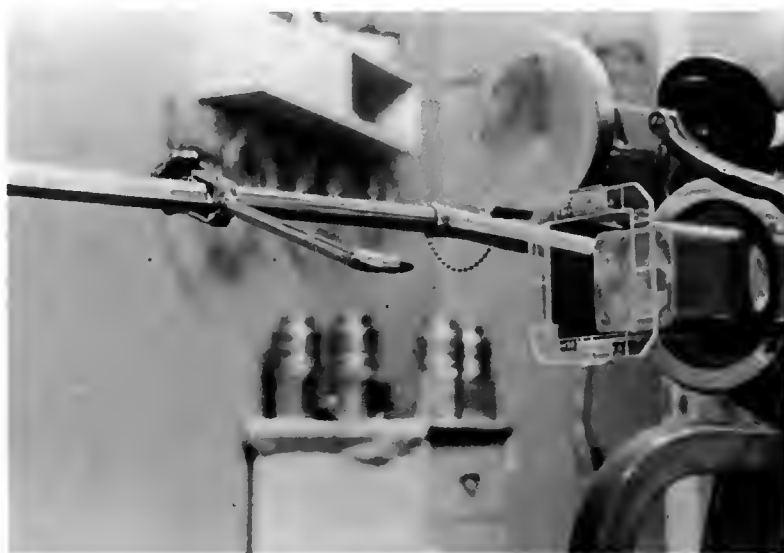

Fig. 4—Back pointer on Keleket-Barnes hectocurie teletherapy unit. A front pointer fits on the device illustrated. This pointer helps to reproduce beam direction after the tumor has been localized by fluoroscopy and by films made with the cobalt machine.



Fig. 5—Beam-direction film made with the cobalt unit in treatment position. The gamma-ray exposure dose of 0.5 to 1 r in air at the film yields a useful film. In comparing this gamma-ray film with the conventional diagnostic X-ray film of the same patient (see also Fig. 6), there is less definition, the ribs are not differentiated from unit-density tissue, and the difference between air and unit-density tissue is well defined.



Fig. 6—Conventional diagnostic X-ray film of the same patient shown in Fig. 5. The trachea was more clearly visualized in the cobalt gamma-ray film.

brosis at the upper pole of the right hilum (Fig. 3), but this has not been symptomatic. (The patient remains free from evidence of cancer more than two years after treatment.)

This case has been presented not only because of the gratifying early result but also because it illustrates a method of averting overdosage to the spinal cord. Most important is the addition of another field to avoid the contribution of high dose to the cord by the two opposing fields. Also of importance is the accuracy of the beam direction. To assure accuracy, a back pointer (Fig. 4) is used, and the fields are checked with fluoroscopy and with diagnostic films exposed with the cobalt unit in treatment position.

Wherever the field includes air and unit-density tissue, satisfactory films can be made with the cobalt beam. Figure 5 illustrates the characteristics of a radiograph made with the cobalt beam. There is less

definition than would be acceptable in routine diagnostic films, a feature attributable to the large source size. The ribs are "washed out" because of the relatively decreased bone absorption of radiation in the 1.2-Mev energy range. The contrast between air and unit-density tissue makes, at times, a remarkably clear picture of a hilar tumor and demonstrates the tracheal air column better than conventional diagnostic radiographs. Figure 6 shows the same patient's chest in a conventional diagnostic roentgenogram.

In summary, the tolerance to radiation of the spinal cord may easily be exceeded by Co^{60} teletherapy because the safeguard of skin reaction is not present. Careful beam direction and control films are therefore important, and a dose of 6000 rads to the tumor should not be given through only two opposing fields if both fields include the spinal cord.

Carcinoma of the Floor of the Mouth, Case Report

CHAPTER 51

Bryan L. Redd, Jr.

Emory University School of Medicine
Emory University, Georgia

I should like to present briefly the case history of a patient who was treated on the unit previously described by Dr. Weens. This unit was loaded in October 1954 with approximately 300 curies of radioactive cobalt. At the present time, it has an output of 21 r/min at 50 cm. The case I wish to present is that of a patient with a lesion on the floor of the mouth.

Figure 1 shows diagrammatically the location of the lesion. He had noted a sore under his tongue for about two months and a node in his left neck for one month. A biopsy specimen was reported to be epidermoid carcinoma, grade II. He had chewed tobacco for 15 years and had smoked for 25 years.

The lesion could be appreciated better by palpation than by visualization. It occupied the major portion of the left side of the floor of the mouth, extended across to the right of the mid-line, and invaded the tongue. There was a left submaxillary node 3 cm in diameter.

Figure 2 illustrates the two opposing fields used. They measured 5 by 9 cm. The source-to-skin distance was 50 cm. The left field received 4600 r (in air), and the right received 4000 r. A mid-line dose of 200 r was given daily for 30 treatments in a total elapsed time of 42 days. The points indicate the dose levels throughout the tissues in the floor of the mouth.

During the third week of treatment the patient developed some mucositis, less severe than that in patients treated by lower energy irradiation. Possibly this is explained on the basis of individual variation and the low daily tumor dose.

Figure 3, taken three months after completion of treatment, demonstrates some atrophy of mucosa in the left side of the floor of the mouth.

Figure 4 reveals little skin change. There was epilation in the lower chin area. The skin erythema started in the fourth week, becoming a deep red; later a dry desquamation developed and then healed.

This patient was clinically well for six months, but he now has evidence of recurrent disease in the floor of the mouth. There are no nodes in the submaxillary region, but there are metastatic nodes in the left supraclavicular area; and, radiographically, there is metastasis in the right hilar area.

This recurrence raises some questions: Was the treatment given too slowly? Should the 6000 r have been delivered in four weeks? Or should we have continued at the same daily dose rate and carried the total tumor dose to a much higher level? If the higher dose is the answer, how high a dose level would have been tolerated by the tissues? Or was this lesion actually radioresistant in the very beginning?

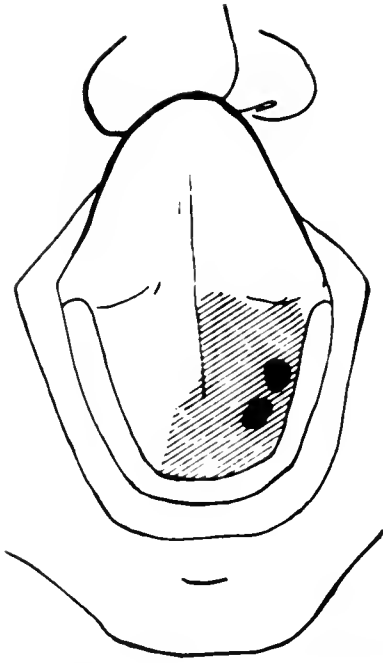

Fig. 1—Diagram showing the position of the lesion under the tongue.

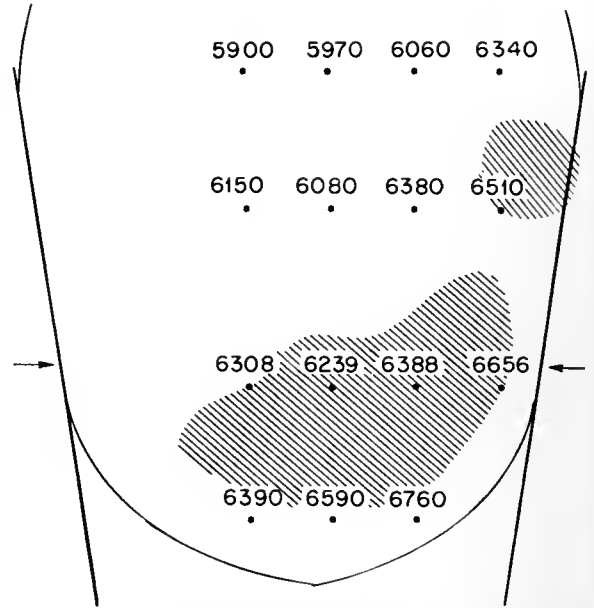

Fig. 2—Dose levels throughout the tissues in the floor of the mouth. The arrows indicate 5- by 9-cm fields; the left field received 4600 r (in air), and the right field received 4000 r in 42 days.



Fig. 3—Photograph taken three months after completion of the treatment.

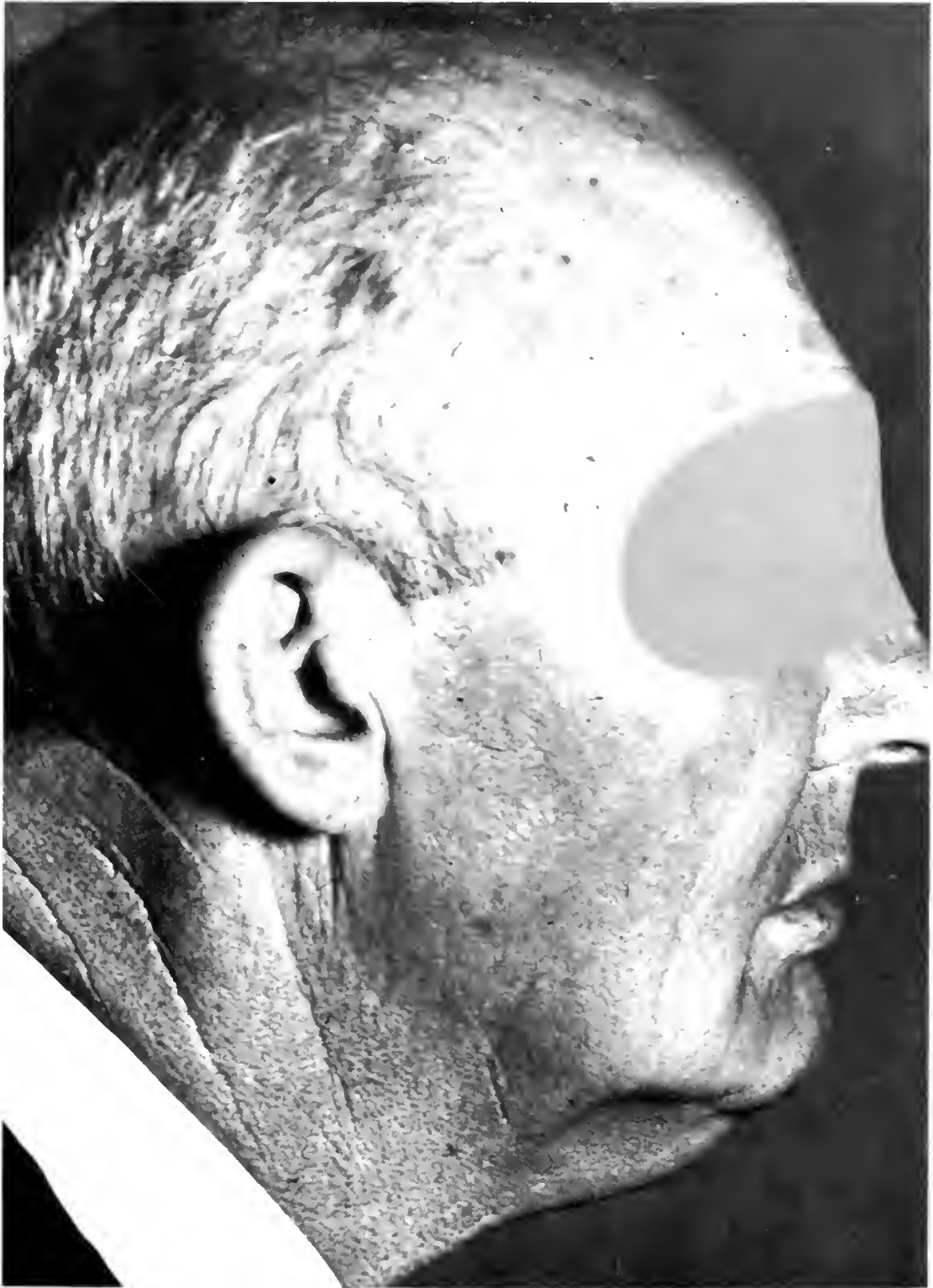

Fig. 4—Photograph showing how little skin change resulted from the treatment with Co^{60} .

DISCUSSION

CHAPTER 52

Freid: The results reported by Dr. Carroll for the lateral border of the tongue are interesting. I think he has had an unusual run of good luck. Lesions of the lateral border of the anterior two-thirds of the tongue are usually well-differentiated squamous-cell carcinomas.

We have unsuccessfully treated several such cases with much larger doses than that reported by Dr. Carroll. We find that we must supplement the external irradiation with interstitial radium or introral X-ray therapy. The primary lesion may show considerable recession with the external irradiation but will not disappear.

The case Dr. Redd reported is more in line with our experiences. The doses necessary to control well-differentiated squamous-cell carcinoma are considerably in excess of what has been stated. I do not believe we can compare the dosage used with conventional radiation with that for Co^{60} or comparable supervoltage therapy. If the dose with conventional irradiation is 5000 to 6000 r, then a comparable dose with Co^{60} would be about 8000 to 8500 r. For some lesions the dose will have to be considerably in excess of 8000 r for complete destruction of the carcinoma.

Friedman: If some of the statements I make are rather vigorous, it is in anticipatory self-defense because Dr. Smithers and I made a pact: whatever I would say, he would oppose, and vice versa, unless either of us were discussing a physical problem, in which event we would join forces.

Supervoltage irradiation has been in use for more than 20 years. Originally, stationary apparatus were employed with simplified techniques; now elaborate moving-beam and moving-patient techniques are coming into vogue. We have just heard of the use of supervoltage radiation with stationary apparatus the same as 20 years ago. We have had a few simple case reports: some early successes, some failures.

So far in this seminar we have not advanced the knowledge or considerations of supervoltage irradiation.

Since this is an important conference, the publication of its proceedings may significantly influence the practice of supervoltage irradiation. For this reason my remarks are going to be vigorous, although at the same time I am making myself vulnerable.

Concerning Dr. Carroll's patient, a tumor dose of 6000 r in 34 days was used. I have no certain idea of what biologic effect 6000 supervoltage roentgens achieves. Our feeling, on the basis of clinical observations, using a relative biologic effect factor of 0.7, would be that this supervoltage exposure dose of 6000 r would be equivalent to about 4200 rads of 250-kv X rays.

If this carcinoma of the lateral border of the tongue subsided with 4200 rads, we must assume that extreme radiosensitivity was responsible for the primary shrinkage and that the mild skin and mucosal reactions were due not to special characteristics of supervoltage radiation but to the very small dose given. The average carcinoma of the tongue will require a much larger dose of supervoltage radiation.

Dr. Carroll states that the incidence of bone necrosis is reduced. In my own experience I have produced the same amount of bone necrosis with supervoltage radiation as with 200-kv radiation. Based on this and other reasons, I predict that the theoretical bone-sparing effect of supervoltage radiation will not be realized clinically.

At the Supervoltage Symposium in Chicago in December 1955, one other speaker who had had considerable experience also stated that the bone complications were the same with supervoltage radiation as those with conventional radiation.

There are a number of unexpected paradoxes in supervoltage irradiation. On the basis of deductions from physical measurements, we expect certain results, but these often do not materialize in clinical practice. We should not be too hasty in applying theoretical deductions to clinical expectations unless there has been considerable clinical trial. I am not implying that the physical measurements and the de-

ductions therefrom are incorrect. I am only stating that it is often difficult to demonstrate them clinically.

Dr. Carroll said that mouth tumors do not lend themselves to rotational techniques. My own opinion, and it is offered as an opinion, is that the greatest field of usefulness for supervoltage rotation therapy is going to be in carcinoma of the head and neck, wherein one can include the primary tumor and neck-node drainage area within the same cylinder of irradiation similar to radical "in continuity" surgery. Since the cylinder of high dosage is often unilateral, the impact of the irradiation on the patient is mild.

I have tried to demonstrate that one of the unwise techniques to be employed with supervoltage radiation is the use of two opposing portals. There are a few exceptions to this rule.

If one is aiming for lethal doses for the less sensitive oral and pharyngeal cancers, the tumor doses must be higher than 6000 supervoltage roentgens, or rads, or riddles.

The range — at least in our experience — the reasonable range must be between 8000 and 9000 rads, with an occasional dose of 10,000 rads. Several other radiotherapists experienced in supervoltage irradiation hold a similar opinion. Dr. Freid has just voiced this opinion.

If we are aiming to increase the cure rate of cancer by employing supervoltage irradiation, we must undertake to treat lesions that are not curable by other techniques. The intra-oral carcinomas shown were either radiosensitive or curable by means of other techniques. These case histories have not demonstrated the superior value of supervoltage radiation.

The superior value of supervoltage irradiation will come in the less sensitive tumors, which require larger doses than we are capable of delivering with conventional techniques. Furthermore, if tumor doses of 8000 to 9000 rads or more are required, the pharyngeal mucosa and the laryngeal cartilages will not tolerate these enormous doses if they are delivered throughout the whole of the oral cavity and neck region by means of a two-portal cross-firing technique.

Dr. Simon has demonstrated one advantage of supervoltage irradiation in the case of carcinoma of the lung, namely, the mild skin reaction. One can effectively treat a patient more comfortably with supervoltage irradiation, but, in my opinion, this factor alone does not justify the expense of supervoltage equipment. To validate supervoltage radiation, the cure rate must be significantly increased.

At a symposium in New York last year, I presented a series of carcinomas of the lung irradiated with 2-Mv X rays, giving rather large tumor doses ranging from 5500 to 7200 rads. There were a certain number of one-year and two-year survivals.

Another radiologist, with a 250-kv X-ray machine, employed similar techniques but smaller doses. He achieved the same results. He cured, or at least palliated satisfactorily, the very radiosensitive lesions and did not accelerate the demise of any patient with overdose. I palliated a few more lesions than he did

percentagewise, but the increased morbidity and fatality with the somewhat larger doses neutralized these achievements.

This emphasizes the axiom that in cancer of the lung the lesion defeats us, rather than the technique or the modality. It is quite probable that the number of unusual or unexpected cures in carcinoma of the lung may be slightly increased, but the over-all impact of supervoltage radiation on this disease will not be significant.

Dr. Redd's carcinoma of the floor of the mouth is ordinarily a radiosensitive type of tumor. It received a tumor dose of 6000 supervoltage roentgens in 42 days. I think the chief reason for the residuum was that the tumor was underdosed.

A biologic characteristic of this particular tumor was unduly aggressive growth. Sometimes the growth aggressiveness of a radiosensitive tumor is such that the tumor recurs rapidly in spite of the early rapid shrinkage of the lesion.

Thus there are two possible explanations for this failure. I prefer to use, as explanation for the recurrence, the fact that the administered dose of 6000 r, or rads, actually produced the effect of a clinically absorbed dose of 4200 riddles. I suggest that it was underdosed, although I know others will differ with me.

Corpender: I should like to differ. All the poor results that we have had in our very limited experience at the University of Chicago have been from what I have considered overdosage. We began with a low dose, and then we increased it to what we considered to be too high a level; our results were poor. The levels that we reached were on the order of those which Dr. Friedman advocates.

I think that Dr. Friedman should be reminded that, at the conference to which he referred, he did "get a ticket for exceeding the speed limit."

Ellis: Dr. Friedman knows that I think he gives doses that are certainly larger than any I have ever been able to give.

Dr. Redd, was the dose 6300 r in six weeks?

Redd: Yes, sir.

Ellis: I think a lot depends on what we consider the relative biological efficiency (RBE) of radiations to be; I do not know of any very good experimental evidence for a definite figure, but it is said to depend on the linear energy transfer (LET). If so, I should think it ought to be in the neighborhood of 0.85, the ratio between LET for 250-kv and Co⁶⁰ radiation.

Loevinger: I do not think this question can be answered by an examination of the LET of these radiations. The RBE of different radiations is strictly a biological number, which cannot be determined by any number of physics experiments.

Ellis: Dr. Carroll said that he did not notice any differences in reaction.

I think that Dr. C. A. P. Woods's experience at Hammersmith Hospital (London) was, also, that she

did not notice any difference in reaction in the mucosa between a radium beam and 250-kv X rays treated under identical physical and time conditions.

Thus, although there probably is a difference in efficiency, I do not think we know exactly what it is yet. However, I think doses of 8000 to 10,000 rads, especially to the whole of the mouth and pharynx, would be too great.

We must not forget that all tumors do not have the same radiosensitivity. I have seen a man with a tumor that disappeared completely with a dose of 2400 r; it was on the floor of the mouth, in the alveolus, and in the cheek. He was an alcoholic; I have noticed that people who have been real toppers seem to have an increased radiosensitivity of the mucous membranes and the tumor.

Since Dr. Redd's patient had a history of tobacco chewing, there was probably a lot of submucosal endarteritis and fibrosis which might account for some degree of radioresistance.

I should like to mention one other point in connection with the lung patient: I think the shadow in the cardiophrenic angle in the posttreatment film is fibrosis. Even when the patient is given treatment to the upper lobe, a shadow stretching right from the diaphragm may develop, sometimes pulling it up. I have seen this in many films.

Did you, in your dosage, make allowances for air-containing lung, or did you just assume it was made of water?

Simon: We assumed it was made of water.

Ellis: Thank you. This means the dose was probably higher than 6000 rads, does it not?

Simon: I should like to discuss radiation fibrosis and its effect on the diaphragm. We, too, have observed the tentlike deformity of the diaphragm, with the peak directed upward toward the treated area. The appearance is characteristic of radiation pleuropulmonitis.

I prefer the area between the dose recommended by Dr. Friedman and the other, lower range. However, I would take distinct issue with Dr. Friedman's discussion of the benefits of supervoltage therapy. If Dr. Friedman felt that he would hear of stationary therapy with the cobalt beam as a dramatic cure for insensitive cancer, it was unreasonable, because I do not think that any of us were expecting that much of an advantage.

In reply to his statement—if I may attempt to quote him almost verbally—"This sparing of the skin reaction does not warrant the supervoltage equipment," I would say that the skin-sparing effect itself, if the only advantage of cobalt, or supervoltage, therapy, is worth the expenditure.

Dr. Friedman also stated that some lesions in the mouth could better be treated by rotation because of the localization of the irradiation. I would comment that some intra-oral lesions are the only cancers, other than skin cancers, which we preferentially treat by means other than cobalt. We think that we can treat some small intra-oral lesions, including

tongue lesions and buccomucosal lesions, more effectively with an intra-oral cone at short distance with 200-kv X rays or with radium.

I do not agree with the view that supervoltage therapy will prove its value only by curing more of the less sensitive lesions. Therapy with cobalt is a distinct improvement over 200 kv even without definite evidence of more cures. The value to the patient of minimal skin reaction and decreased radiation sickness is clear cut.

Tubiana: We have heard during the discussion that some tumors were undertreated and that others were overtreated. One could think that any dose might be insufficient for some radioresistant tumors and too much for some radiosensitive tumors. If the dose is increased, the number of sterilized tumors will certainly increase, but beyond a certain threshold the number of complications will also increase. Optimum dosage is the dosage for which there will be the greatest number of sterilized tumors and the smallest number of complications.

The whole point is to determine the optimum dosage, which could be very difficult because it could vary with the tumor. Such a determination requires that a great number of tumors of the same type be treated with the same dose and followed for a very long time. This work has been partly accomplished with classical radiotherapy, but it remains to be finished with high-energy X rays.

The same thing could be said about volume. It is difficult to know what the optimum volume is for an irradiation. If the irradiated volume is small, a high dose can be tolerated, but some cancer cells might lie outside the field of irradiation. If the volume irradiated is too large, the risks of complication in adjacent tissue will increase.

I think it will be a long time before we know the optimum dosage and the optimum volume for high-energy radiation. Only with the systematic treatment of series of patients treated in the same way can we determine these values.

Smithers: Dr. Friedman seems to invite controversy. The first thing that occurred to me while he was talking was that everyone else's tumors are very radiosensitive.

He also said that supervoltage has existed for 20 years. Telerradium has existed a good deal longer, of course. One of the interesting things, to me, about this discussion is the small amount of attention being paid to the very good experience provided by telerradium.

After all, the use of cobalt in irradiation of tumors of the head and neck region is only what has been done for 30 years or more. One might have heard exactly the same words we have heard being said 20 to 25 years ago.

I think that one thing of extreme importance which only Dr. Tubiana has mentioned so far is the question of volume. With regard to the pictures that have been presented of tumors treated in the mouth and to the

questions asked about dosage—whether or not it should have gone higher—the thing that occurred to me all the time was that the volume should have been smaller. These large opposing fields that cover the whole of the face and the mouth are not the best means of getting rid of squamous-cell carcinomas within the buccal cavity. I am sure we should pay much more attention to the volume being irradiated.

I should also like to say that I think we are discarding much of the value of supervoltage if we pay less attention to the number of fields and to care in setup than we did with the lower voltages. Just because we have supervoltage, we do not want to use single fields or very simple setups; we still want to do the best we can with what we have.

The last subject I should like to take up is bone necrosis. I think here we tend to mix things a little. I do not believe there is any doubt that the incidence of bone necrosis with X-ray treatment is higher than that under similar conditions with supervoltage or teleradium. Nevertheless, teleradium has a bad reputation for bone necrosis at one particular site—the jaw. But this is for quite another reason; it is because of the shape of the teleradium isodose curves. They are splayed out, and, when two teleradium fields are placed close together, the area of overlap just below the surface produces a very high dose region. The bone necrosis of the jaw occurred because of the way that multiple teleradium fields were arranged close together over bone, with the overlap and the high dose just below the surface.

The 2-Mv radiographs or any high-voltage radiographs are most interesting things. I think this is quite a useful development, in itself, as a diagnostic tool. The radiographs of the nasopharynx are some of the best I have ever seen of tumors at this site taken with 2-Mv X ray.

My last comment is this: people keep talking about “conventional” X-ray therapy for the mouth and head and neck. If this is a convention, it is a thoroughly bad convention. Much better treatment has been available for a very long time.

Friedman: In trying to make one point by overstressing it, I seem to be acquiring the reputation of being a radical overdoer.

In discussing specific cases with visitors to our clinic, we find that a high percentage of the visitors use the same dosage we use.

The percentage of radiocurable tumors is small. Failures, due to recurrences of irradiated lesions, are large in number. A significant percentage of the failures due to local recurrences are caused by underdosage.

In the first clinical demonstration, supervoltage techniques were discussed at a level that was discussed 20 years ago. Instead of being excited over these demonstrations, we should recall that we are 20 years back only as far as this first clinic is concerned. Remember, this is the first of three clinics. I am trying to avoid projecting the discussions into

subsequent cases because within four days we expect to advance 20 years.

Let us look again at Dr. Tubiana's two curves (Fig. 1), which show the relation of dose to cure and dose to radiation injury. For deep-seated lesions having lethal doses up to 4000 rads, satisfactory tumor arrest can be achieved without supervoltage irradiation.

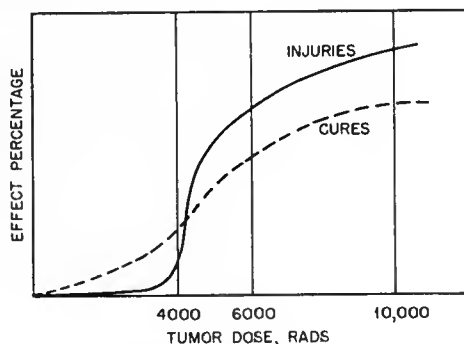

Fig. 1—Graph showing a correlation between the number of cures and the number of injuries produced by irradiation as the tumor dose increases.

It is the next group of tumors, whose lethal-dose range is 4000 to 6000 rads, which we have discussed so far. When these tumors lie in the chest or the abdomen, there is great risk of injury to lung or abdominal viscera. Precision techniques are required to minimize these.

Now let us direct our attention to the third group of radioresistant lesions, those requiring more than 6000 rads. This group includes, among others, many so-called “radiocurable” tumors. Mid-treatment serial biopsies often indicate that a particular tumor is radioresistant and that, with a conservative or optimum dose, i.e., 5000 to 6000 rads in 28 days, the treatment will fail. It is in the group of lesions requiring lethal tumor doses of more than 6000 rads (Fig. 1) with which I am for the moment concerned. It is for this group that radically large doses must be given. It is necessary to shift from the optimum-dosage philosophy described by Ralston Paterson to the concept of radical irradiation therapy, wherein one accepts calculated risks of radiation injury and is willing to trade these risks for a possible increase in cure.

This decision is not strictly a scientific one. It is a personal, emotional, and philosophic decision. Some people are constitutionally incapable of being aggressive; others are more aggressive. These aggressive fellows may even be sadists; I often ask myself whether I am. Not infrequently one can correlate the philosophy of radiotherapy with the personality of the radiotherapist. Occasionally one can predict beforehand the kind of radiotherapist an individual will be. Some men refuse to produce a second-degree erythema because of fear; others, because of conviction. A few will produce a severe third-degree erythema if that is the only way to cure a cancer. This latter principle

of radical aggressive treatment is the foundation of much of modern cancer surgery.

It is for this group of resistant cancers requiring more than 6000 rads that I have been stressing large doses. One must not cite out of context my overstatement, made in order to emphasize a point, as a description of a general philosophy. I think that the principles behind radical radiation therapy are, to some extent, substantiated. Although the philosophy is radical, it is not wild.

Ellis: The question was asked about implants of these lesions. I make a practice of treating to a dose of only 1000 or 2000 r with X rays and then implanting the tumor with radium or radioactive tantalum to a total dose of 6000 or 6500 r in a total time of something like 8 to 14 days.

I like the implantation because it keeps the volume of tissue irradiated to the smallest possible limit; I

give the X rays first because they lower the high spots and raise the low spots of dosage due to the implant.

I do not know whether Dr. Friedman thinks I am sufficiently aggressive. When I played football, I was called "Tiger." I do not know what I am like as a radiotherapist, but I try to be scientific even in this region. I can show you many patients with normal-looking tissues who were treated according to my philosophy of radiotherapy, i.e., that normal tissue tolerance should not be exceeded. I believe the normal tissues help eliminate the tumor.

I do not want to dilate on this any more just now, but I do think that if one does overdose, destroying the normal tissue tolerance, one is more likely to have residual tumor than if one gives the optimum dose.

Simon: In response to an earlier question, the exposure dose to the film, in taking radiographs with Co^{60} , is 0.5 r. It is nonscreen film in a cardboard cassette, with the lead screen on the beam side.

Section K

Clinic on Moving Fields

J. W. J. Carpender
(presiding)

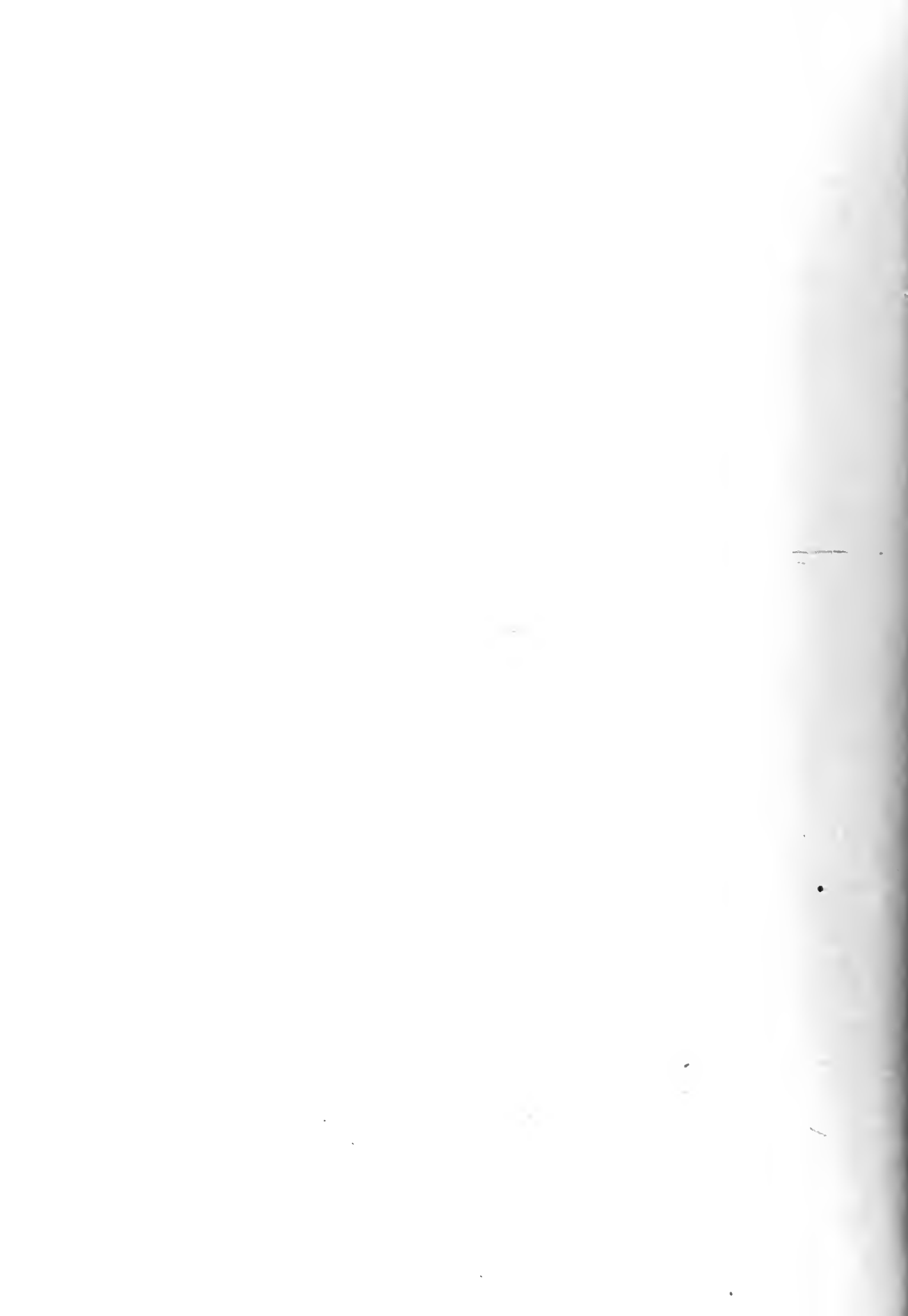

Reticulum-cell Sarcoma of Nasal Sinus

CHAPTER 53

J. W. J. Carpender

University of Chicago
Chicago, Illinois

Each of the three therapists has been asked to present a typical moving-field clinical experience and to emphasize a point in which a moving field accomplished something that would not have been possible with a stationary field.

This is a little difficult; at least it is for me. I suspect that most things we have done would have been possible, but extremely difficult, without moving-field therapy.

My patient, a radiologist, aged 42 years, when first seen in December 1954, gave a history of sinusitis of the right antrum for several years.

In February 1954, he had acute left sinusitis, and X-ray films made at that time indicated a very rapid change from the previously reported normal condition to definite disease of that side. The E.N.T. Department at his hospital treated him for sinusitis intermittently until, in November 1954, a small mass appeared in the left submental area. A biopsy of the mass showed a reticulum-cell sarcoma. Examination revealed a small (1.5-cm) exophytic lesion on the right side of the nasal septum posteriorly. A biopsy of this area revealed reticulum-cell sarcoma similar to the mass in the left submental area.

For a number of reasons, but primarily because we have cobalt, this patient was then referred to us for radiation therapy.

Our X-ray examination revealed clouding of both maxillary antra. Because of this and because the patient had right nasal septal disease and left submental node disease, we felt unable to proceed without more detailed examination. Bilateral Caldwell-Luc procedures were carried out. Reticulum-cell sarcoma was found in the left antrum, and thickened mucosa due to chronic sinusitis, in the right.

Careful clinical examination of the patient disclosed no other evidence of the basic disease. However, there were several other complications.

In about the center of his forehead, the patient had what I first thought was a malignancy; but, on examination by our dermatologist and excision biopsy, it

proved to be a benign kerato-acantho molluscum sebaceum. In addition, he had a severely damaged skin. There were at least three areas where cutaneous malignancy had already been treated, two of them in the skin area through which we thought we would have to direct irradiation.

The patient had had vigorous treatment for acne in his youth. He was redheaded. He had lived in an area of brilliant sunlight all his life. His hobby was gardening. When our dermatologist, who saw him because of the benign forehead lesion, learned that I planned to treat him by means of external radiation, I received a rather abrupt answer to my request for advice. I was told that I was crazy to treat him that way.

I am not exaggerating any of this; the patient had one of the most severely damaged skins that I have ever seen. His face was a mass of fine, tiny telangiectases. Nonetheless, after due consultation with the patient, since he was a radiologist, we decided to treat him.

We prescribed sector rotational therapy, with a 6-by 8-cm portal, about the anterior portion of the face, omitting a posterior segment of 120 deg. The upper border of the portal was at the inferior border of the orbit. The center of rotation was to the left of the mid-line in the approximate center of the tumor-bearing tissue.

The calculated depth dose in the center of the lesion was 79 per cent of the air maximum. A daily tumor dose of 250 r in 23 treatments for a total calculated dose of 4600 r was delivered. The skin dose was estimated at 3700 r maximum.

Midway through the course of treatment, the patient complained of soreness of the tongue. Three days after this there was a definite mucositis of the dorsal surface of the tongue, and, to alleviate this, a saline-moistened sponge was placed in the mouth to depress the tongue inferiorly at the time of treatment.

Near the end of treatment a slight erythema with some desquamation appeared over the face at the portal site, in addition to the previous reaction he had shown.

There were similar reactions of the skin in the left submandibular area which had been irradiated at the same time through a 5- by 5-cm square portal over the area of the involved node to a total tumor dose of 4000 r.

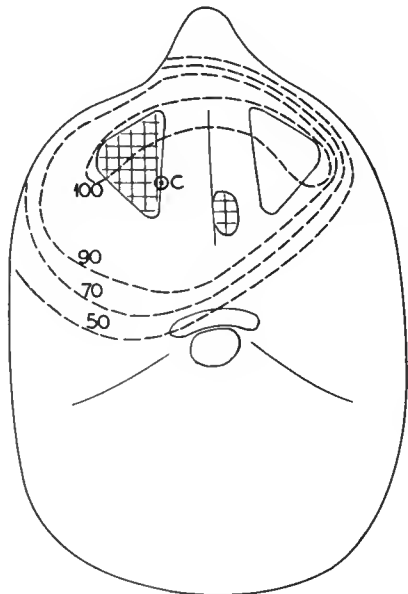

Fig. 1—Isodose pattern for sector rotation for lesion of nasopharynx and contralateral nasal septum.

At this time the posterior aspect of the left superior bucco-alveolar gutter was involved by a brisk mucositis. There was sharp reaction in the soft palate and posterior portion of the hard palate. The tongue mucositis had been relieved by depression of the tongue by means of the saline-moistened pad. The patient looked

well but was troubled with mild xerostomia and anorexia.

Treatments had started Dec. 16, 1954. On completion of the treatment on Jan. 4, 1955, the skin showed a mild reaction. The soft palate showed moderate mucositis. The patient had lost 6 lb of weight during the course of treatment. The left submental node area felt hard on palpation, but there was no discrete mass. The patient complained of moderately severe loss of salivation and a loss of taste. His dental status was normal for his age.

A follow-up study of this patient indicates that the primary disease was completely eradicated. One and one-half years after treatment a metastatic lesion, which was irradiated by medium-voltage therapy at his own institution, appeared in the lumbar spine. This was about nine months ago, and there has been no other evidence of disease up to this time.

I am convinced that, because of the occupation of the patient, the previous radiation therapy, the radiation therapy for cutaneous malignancies, his avocation of gardening, which entailed exposure to the sun, and the extent of the disease when he was first seen, this treatment would not have been readily possible without using an extremely complicated arrangement of multiple beam-directed portals.

Figure 1 shows the dose distribution in this patient. I am sure that it is not perfect, but at the time it was the best we could do under the circumstances. It is not too bad, and it can be seen that we did spare the cord and the base of the brain. The portals were so arranged that there was no conjunctival reaction.

This is a brief presentation of an extremely difficult problem. I hope, for our own part, that we do not have very many patients of this kind. I think we got away with something that was quite difficult and obtained a fairly good result.

Rhabdomyosarcoma of the Neck; Radiation Myelitis

CHAPTER 54

Magnus I. Smedal

Lahey Clinic
Boston, Massachusetts

I think I could have selected easier cases to present, and some with much happier results than this one. The patient was a four-year-old child who was referred from Children's Hospital, Boston, Mass., in January 1954, following exploration of the submental area. At the time of exploration she was thought to have a branchiogenic cyst, but at surgery a solid mass was found. It was removed and later reported to be rhabdomyosarcoma. Having had experience with two or three other rhabdomyosarcomas in children, we knew they were very serious, and therefore we knew this one was going to be bad.

Before the child came to us, Dr. Robert Gross of Children's Hospital had re-explored her. He found a tumor extending up to the base of the tongue, but there was no tumor in the tongue nor as far down as the larynx. We began treatment Feb. 17, 1954, with a 5-by 5-cm field, opposing portals; in seven weeks we delivered a tumor dose of 7200 r in 33 treatments, using 2-Mv X rays.

The skin tanned and she had a very mild inflammation of the pharyngeal mucosa. We stopped treatment because she was becoming unable to eat properly, and, since our patients are out-patients, we had to desist at that point.

Six months later, nodes developed below the treated area. She was re-explored at the Children's Hospital, and nodes were found on both sides of the neck, below both poles of the thyroid, and around the right carotid artery. Dr. Gross did not attempt anything radical. He asked us if we would try again, and so we did.

We decided that, to re-treat her, we would have to use more or less the same procedure as that for thyroids; but, having no knowledge of the results in children of this age, we did not dare put a very large dose into the cord. We therefore decided to give half the dose by opposing portals and half by a scanning technique.

Figure 1 shows the original treatment field, which includes the entire tongue down to the level of the larynx. Figure 2 represents the field used for the first

3000 r of the second series, with opposing anterior and posterior portals; it included the neck from the level of the larynx down, the supraclavicular areas, and the superior mediastinum. The width of the mediastinal extension is 4 cm. In adults we usually average a 6-cm-wide mediastinal extension. With wider fields and rotation, there is considerable irradiation outside this 6-cm area, and I would suspect that those who rotate fields wider than 6 cm in the chest can expect lung fibrosis of considerable degree.

When we had completed the 3000-r dose with opposing portals, we changed to rotation. To spare the cord, we split the field into right and left halves, treating each on alternate days (Fig. 3). In addition, we blocked off 2 cm of the mid-line so that a cone of protection shielded the cord at all times. The left side was scanned through 138 deg, from 22 deg to 160 deg, and the right side was done in similar fashion, from 340 deg, through 0 deg, to 200 deg. We used eight weeks to deliver the 6000-r dose; we stopped at this point not because we reached the magic figure of 6000 r but because I did not believe the child could tolerate more.

Two weeks later, pain developed in the left thigh, and the child had a fever of 101 to 103°F. Radiographs showed definite periosteal elevation, which we assumed to be metastasis similar to an early stage of Ewing's sarcoma. We treated her with X rays, and her pain was relieved with a 1500-r tissue dose.

Four months later she developed difficulty in walking. In a few weeks she became paralyzed, the level being D-5. She was admitted to Children's Hospital, where she stayed for nearly a year, until about two weeks before her death. She had a cord bladder. At post-mortem examination, tumor throughout the viscera and bones and a residual tumor in the neck were found.

The cord particularly interested me, and I thought my report would be favorable in regard to the irradiation used. I called the hospital just before I left to attend this meeting, but the permanent sections had not been examined completely. The child lived one and one-

half years after we first started treating her and one year after cord paralysis developed. The cord showed gross system degeneration from C-5 level to about D-5, which is just about our treatment area, but it had not been determined whether this was due to irradiation.



Fig. 1—Two million volt radiograph of first treatment field.



Fig. 2—Two million volt radiograph of the opposing-portal treatment field.

I present this patient from the standpoint of cord damage occurring with a minimal dose of 3000 r, and it is possible that one area at the level of the fifth cervical vertebra may have received an additional 800 r. I should like to know if anyone has seen actual degeneration occur as a result of 3800 r delivered to the cord in eight weeks.

I should also like to know how many have seen cord damage result from X ray and in what percentages it occurs. We have treated over 100 patients with thyroid carcinoma to doses of 4800 r; I think the cord received nearly this much dose, but no cord damage has re-

sulted. We have had just as many lung and esophageal cases. We have treated close to 200 head cases, and a great number of these were treated through the cord also. One patient with parotid carcinoma had Brown-Séquard's syndrome. He had a recurrence five years after we treated him.

One other patient had a complete cord transection. He had Hodgkin's disease and was treated through two



(a)



(b)

Fig. 3—Two million volt radiograph of rotational field. (a) Anteroposterior view. (b) Lateral view (note field anterior and lateral to cord area).

overlapping fields with 2400 r. He had had previous irradiation too. We must agree that this patient probably received 4800 r in an area of overlap of less than 0.5 cm; exploration showed this. However, we think the dose may have been given too rapidly since we have not observed this in any of the other lymphomas or in the thyroid, lung, or esophageal cases we have treated.

I should like very much to hear an expression from the rest of you about what you think the proper dose or the top-level dose should be to the cord. I should also like someone to tell me how to treat some of the cases of head and neck tumors with widespread metastases that reach as far back as the tip of the mastoid so that they are in the posterior triangle. How does one adequately cover the field and also avoid the cord?

Metastatic Carcinoma of the Lung

CHAPTER 55

Ruth J. Guttman

Francis Delafield Hospital
New York, New York

Abstract

A group of patients was selected who presented themselves with widespread bilateral lung metastases from primary carcinoma of the testes, cervix, or breast.

Treatment approach with full rotation and preliminary results are described. A rotating Co^{60} machine was employed.

It is difficult to describe a patient or a series of patients who should be treated exclusively with rotation. Most problems with supervoltage irradiation can be solved with stationary fields, and therefore any possible advantage from rotation will be only very slight.

The final choice of technique was dictated by the great ease and elegance with which we have treated a group of patients who could have been treated with stationary fields, but it would have been much more difficult and much more time consuming.

Case 1. More than two years ago, in March 1954, a patient was referred for supervoltage therapy. A testicular tumor had been removed in 1951, and he received at that time prophylactic therapy to the inguinal, pelvic, and para-aortic nodes. The patient was completely asymptomatic, but a routine chest radiograph taken in March 1954 revealed bilateral lung metastases. There was no other demonstrable evidence of disease.

The patient, aged 36 years, was in excellent condition. Microscopic examination of the specimen showed embryonal carcinoma. At fluoroscopy there was mediastinal enlargement in addition to bilateral lung metastases (Figs. 1 and 2).

With this microscopic diagnosis and with such widespread lesions, it was necessary to treat aggressively not only both lung fields but also the mediastinum. We had to deliver a dose that was adequate but not large enough to cause pneumonitis and fibrosis, in case the patient should live long enough

to have these aftereffects. It appeared that total rotation would serve the purpose best.

Figure 3 shows the contour of the patient. The anteroposterior diameter was 26 cm, and the lateral diameter was 38 cm. We treated the patient through a 17- by 8-cm field with full rotation. The dose distribution was uniform in the mediastinum and then tapered off slightly in the lateral fields.

The spinal cord received, for 4000 r given to the mediastinal area, only 2650 r. In other words, the best dose was delivered to the region with the most massive disease; yet there was still a good dose throughout both lung fields, with a relatively small dose to the spinal cord.

The total treatment time of this patient was four weeks. We gave a daily tumor dose of 200 r and a total dose of 4000 r to the area that received the maximum irradiation. The other areas had 3720 r, and the spine had a dose of 2650 r.

The treatments were tolerated extremely well in spite of the tremendous volume treated. The patient had no side effects, no esophagitis, and he went on with his daily routine. There never was a skin reaction after the treatment.

A chest film taken three months later showed that the masses had apparently disappeared. I was not certain about the hilar areas as yet. We did nothing further, however, but waited, especially since the patient was asymptomatic. The patient is now alive and well, two years and three months after completion of therapy.

Figures 4a and 4b, the most recent films, show no evidence of disease. The patient never, in this time, had any pulmonary symptoms, and there were no signs of pneumonitis or fibrosis.

Case 2. Encouraged by the ease of the preceding approach and by the result, we have used the same technique in a group of patients and have had the same excellent local results in all of them. We have had one other patient who had an embryonal carci-



Fig. 1—Radiograph showing lesions from primary embryonal carcinoma of the testis scattered throughout both lungs.



Fig. 2—Lateral film of patient shown in Fig. 1.

METASTATIC CARCINOMA OF THE LUNG

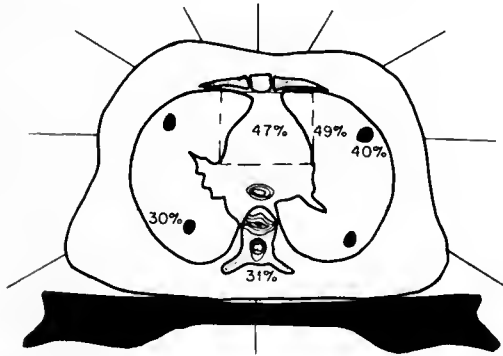

Fig. 3—Contour of patient to be treated with Co^{60} rotation therapy. Figures indicate dosage to various points calculated in terms of percentage of air dose.



Fig. 4—Anteroposterior (a) and lateral (b) chest films taken two years after therapy. There is no evidence of disease, and there are no visible changes as a result of therapy.



Fig. 5—Radiograph of another patient with bilateral lung metastases from carcinoma of the testis, taken before Co^{60} rotation therapy.



Fig. 6—Radiograph of patient shown in Fig. 5 taken nine months after completion of therapy. Lesions have cleared.

noma. Figure 5 demonstrates the bilateral lung lesions. This patient, however, had severe hemoptysis, dyspnea, and cough.

Figure 6 is a radiograph taken nine months after completion of therapy. At that time the patient felt well. He had lost all his complaints as far as his pulmonary symptoms were concerned. However, he had known disease in other areas and died about a year after therapy to his lungs.

The other cases were patients with primary lesions of the breast with widespread lung metastases, but no other evidence of demonstrable disease, and there was one patient with carcinoma of the cervix, with bilateral lung metastases. The time elapsed since the completion of the treatment has been too short to enable me to form an opinion on the end results. However, the immediate palliative result was good.

Obviously, these patients could have been treated with stationary fields. However, in a patient with a

huge thorax, such as the first patient, we would have needed four pairs of opposing fields. The total treatment time would have been much longer because more than two pairs of fields could not have been treated daily. Even with the 2-Mv unit I would not have liked to treat more than one entire lung per day. With this arrangement the total treatment time would have been twice as long as that with rotation.

This is therefore a variation of the usual patient whom we routinely treat with rotation. However, with this flexible machine, I believe that one should think more in terms of the atypical situation, the one patient in many who represents a special problem and shows a very unusual situation; the very large patient, such as the one in this instance, or the patient who, for one reason or the other, cannot be turned for administration of the opposing fields. In other words, it is the extraordinary patient who demonstrates best the main advantages of the Co^{60} rotating unit.

DISCUSSION

CHAPTER 56

Berman: It is always dangerous when two cross-firing portals irradiate the spinal cord. Dr. Friedman and I recently saw a patient whom he treated 10 years ago with one million volt X rays for carcinoma of the testis; he now has paraplegia.

D. Quick: I had two patients in whom I think the cord was damaged.

I can readily understand Dr. Smedal's feeling that the cervical cord was quite possibly damaged with that amount of radiation. It was 5000 r, was it not?

Smedal: No, it was 3000 r direct, and possibly an additional 800 r resulted from rotation.

D. Quick: The first of my two patients had a large epidermoid carcinoma of the tonsils, grade II, and a large fixed mass of metastatic nodes. He received about 7000 r to the tumor with a radium-beam unit. About one year later he returned with early signs of cord damage. He went downhill rather quickly and died; an autopsy was performed. The neuropathologist felt that there were not sufficient changes in the cord to warrant labeling it irradiation damage. I still feel that it was damage to his cord.

The other patient was a man who received about 8000 r for extensive carcinoma of the base of the tongue with involvement of cervical nodes bilaterally. The tumor dose was about 8000 gamma roentgens in six weeks. His primary growth was controlled; one node remained stationary and did not change over a period of time, and I had planned to transfix it with radium-element needles. He then began having some peculiar throat symptoms, a feeling of wanting to eat, trying to swallow, and not being quite able to get food down. This continued and he grew worse; he began losing weight rather rapidly. The neurologist who saw him three or four times felt that he more probably had a metastatic deposit in his brain than cord damage. We had no autopsy performed, but, again, I personally feel that we had damaged his cord and this was the answer to it.

I hope the following comment will not be misinterpreted because it may sound a little callous. We have treated many people with heavier doses and have not damaged their cords. We are dealing with a lethal disease, usually in an advanced stage, and if we were to stop at a low level and not treat all the others who got by with larger amounts and who have gotten good results with it, then we should lose many more patients from lack of irradiating them to a degree that we believe adequate. We should lose far more patients in this way than by the occasional damage in the odd case where we cannot foretell a peculiar sensitive cord.

Eberhard: I want to ask Dr. Guttman a question that arises from my ignorance as one of those on whom the financial "gods" who donate million-volt apparatus never smile.

She stated that with fixed-portal therapy it would have taken twice as long to treat this patient as with moving-field therapy. I can understand why it probably would have taken me twice as long because I am too lazy to set up so many fields in one day. Basically, she was endeavoring to administer x roentgens in a given length of time to a certain volume, and I wish to inquire why it would take twice as long to administer it through six or eight fixed portals as it would by rotation.

Friedman: In our series of 232 tumors of the testis, 10 per cent of the patients who received doses larger than 5000 r to the spinal cord or cauda equina sustained damage to the cord. This incidence of damage to the spinal cord is corroborated by other reports.

Each type of radiation injury is produced not by a single dose level. There is a wide range of radiosensitivity not only of tumor tissue but also of normal tissue. As Dr. Quick rightly stated, if one has some idea of the percentage incidence of risk in a particular situation, he may take that risk in aiming for a cure that is not otherwise attainable.

To this day, I do not hesitate giving the spinal cord 5000 r or the brain a still larger dose if it is the only way to save a patient's life.

I should like to re-emphasize a figure I showed earlier. It illustrated the isodose distribution in a chordoma of the vertebra treated with 2-Mv rotation irradiation, wherein the tumor received 7300 r in 47 days, while the adjacent cauda equina, which was only 1 cm distant, received 4400 r. This could be achieved only with a sharply collimated beam, which results in a rapid fall-off in dosage at the margin of the heavily irradiated volume of tissue. It is the rapid or slow fall-off that determines the tissue dose to adjacent normal structures and dictates how large a dose one may dare give to a tumor.

For this reason I suggested that the index of efficiency of a treatment technique be determined by the distance in centimeters from the 90 per cent isodose line (which represents the tumor dose) to the 50 per cent line (which represents the safe dose).

The purpose of rotation is to increase the intensity of irradiation in the tumor volume and reduce it in the normal tissues. With Dr. Guttman's rotating cobalt unit, if the tumor area (mediastinum) received a dose of 4000 r and the normal tissues (spinal cord, which is about 6 cm from the mediastinum) received 2650 r, the dose distribution was poor. The index of efficiency of that machine is poor, probably because of improper collimation.

Collins: I do not know that this is entirely pertinent to the principal subject under discussion, but Dr. Friedman brought it up earlier and again at this time. I cannot resist rising to the relation of roentgen and dose. Dr. Friedman felt that 6000 r was a small dose, and Dr. Ellis said that this was a large dose.

The problems that have been offered at this clinic have been solved or have been questioned in terms of dose delivered, expressed in terms of roentgens. A dose is not a number of roentgens any more than it is a number of days. We will agree that x number of roentgens that are recorded in a given case record constitutes some aspect of a dose. If this same number of roentgens had been given in half the length of time, it would have been a greater dose; if this same number of roentgens had been given in twice the length of time, it would have been a lesser dose.

In determining dose, something must be measured, weighed, or counted. Roentgens, rads, or riddles are rather delightful things that give themselves to measurement.

Over at the other side we do have the biological effects and biologic aspects, which we try to appraise and relate to the number of roentgens. Dose is a concept that there is a duplicable relation between what the physicists so accurately and delicately measure and what the clinicians observe, record, and predict.

Every once in a while the physicists run off with the ball called "dose," because they measure it; just as often the biologists run off with the ball in the other direction, protesting, "No, this is biologic and you cannot measure it." And in between there is very apt to be the patient, who is somewhat strangled by the failure to see dose as a concept rather than as a number of roentgens.

Ellis: A radiotherapist in South Africa called Cohen has been trying to push the idea of a clinical unit of dose. "Roentgens equivalent clinical" is the term, and he called a roentgen equivalent clinical the biological effect of 1000 r in one dose to a field 10 cm in diameter with the gamma radiation of radium. He has produced nomograms relating X-ray doses, gamma-ray doses, and time and area. I think it is a concept that should be followed up. The next step in radiotherapy is to try to produce a rational system of managing it.

Guttman: First, I shall try to answer Dr. Quick's question. If we refer to the actual treatment plan of the first patient, we find that, if we had wanted to concentrate more on lower areas, we could have shifted the center of rotation; then we should have had the effect in that area.

Regarding Dr. Eberhard's question, I have tried to illustrate that both lungs do not get a uniform dose of 200 r daily when full rotation is being used. This is in contrast to the treatments given through two pairs of opposing fields on the 2-Mv unit. With the latter approach we get a uniform dose of 200 r throughout each lung. It follows then that the volume dose with rotation must be less in this case than it is when stationary opposing fields are being used. I cannot prove it, unfortunately, because I do not have the actual figures, but this is one of the reasons why I believe the patients tolerate it better.

In addition to this, the time factor enters. It takes time, even with a fast-working machine like the 2-Mv unit, to set up eight fields. The treatment time in this patient, with a source that was weaker than our present source, took 12 min, and the positioning, about 3 min; therefore it was a very short procedure.

Section

L

Clinic on Unusual Cases

James E. Lofstrom
(presiding)



Carcinoma of the Esophagus

CHAPTER 57

Sidney Rubinfeld

New York University College of Medicine
New York, New York

Abstract

The administration of a therapeutic dose of conventional X rays to a cancer of the esophagus was often interrupted either by perforation of the wall, depreciating nutritional status, or early death. These discouraging events led to the slow removal of cancer of the esophagus from the list of therapeutic radiology. However, the advent of the era of supervoltage and gamma-beam therapy has reawakened interest in this lesion, and again the challenge has been placed directly before us. Two patients are presented to illustrate unusual experiences. They demonstrate the facility with which a therapeutic dose can be delivered into the esophagus, despite age, nutritional limitations, or physical limitations such as maneuverability of the stretcher. The excellent radiographic responses, the clinical improvement, and the survivals make for exciting and unusual experiences.

My assignment was to present a typical experience or patient. I selected a case of cancer of the esophagus wherein unusual roentgenographic changes were observed. Experience has taught me to appreciate some patterns of response of esophageal cancer. First, perforation occurs often during the course of administration of treatment with conventional X rays. Second, deliverance of a lethal dose is frequently interrupted by poor nutritional state. Third, even after a full therapeutic dose in a reasonable time, death occurs invariably within the year. As a result of these discouraging responses, the radiotherapist was seeing fewer patients with these neoplasms. With the advent of supervoltage and cobalt teletherapy, a resurgence of interest in cancer of the esophagus has appeared. Therefore the typical experience aims to present some dramatic changes in neoplasms of the esophagus.

The first patient is an 86-year-old debilitated man with dysphagia of three months' duration, pain in the right upper quadrant, and loss of 20 lb. The pathologist found adult squamous-cell carcinoma.

The age and debilitation of this patient contraindicated treatment with conventional therapy. However, cobalt therapy, we felt, deserved a trial. Figure 1

depicts the characteristic constricting lesion of the mid-third of the esophagus, accompanied by the dilatation proximally.

A moment of digression to discuss some difficult construction problems: At Bellevue Hospital, we installed the cobalt unit in the room previously occupied by a 5-g radium pack. The walls were lead-lined for the radium source, and therefore the cost of the new cobalt installation was minimal, as pointed out by Marshall Brucer earlier. A Keleket-Barnes unit was installed in this room, which was adequately shielded except for the region at the entrance door. Accordingly, a baffle was added. This baffle, however, being situated directly to the left of the door and close to the large cumbersome base of the cobalt unit, caused severe limitation in maneuverability of the stretcher.

One feature, therefore, in this recitation of an unusual experience is the fact that we chose to treat, with cobalt, an 86-year-old debilitated man, who had to be moved into position (rather than the stretcher being moved). Second, these related problems explain the reason for the anterior and posterior cross-firing technique. This is another way of saying that cobalt and supervoltage therapy are easier for the patient and for the therapist.

Figure 2 shows distribution of dosage at several critical areas. The esophagus received 6000 r in six weeks; the spine, 7000 r; the lung at point B, 5340 r, and at point C, 5600 r; and the sternum, 6800 r. This generally represents undesirable and unsatisfactory dose distribution. The results, however, were dramatic (Fig. 3). Radiographically, we can call this regression of tumor. Conventional X-ray therapy is less likely to accomplish this result. The simplicity of administration of 6000-r doses in a reasonable period through anterior and posterior portals, the excellent radiographic response, the clinical improvement of dysphagia, and the survival of the patient all make for a very exciting experience.

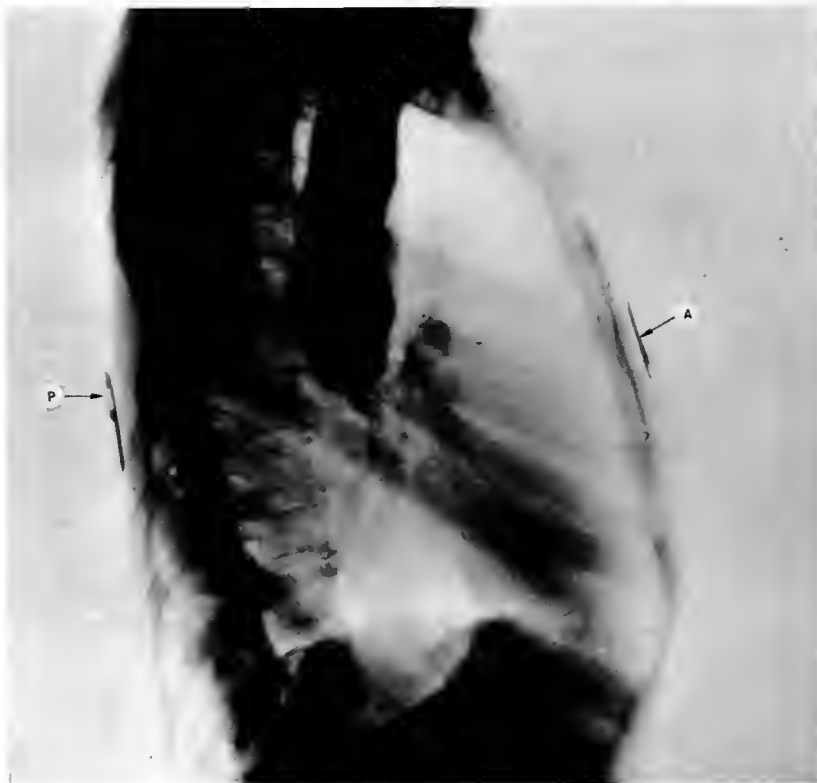

Fig. 1—Radiographic examination of case 1 before treatment. For localization, note the opaque lead markers in the form of the letters A and P on the skin of the chest in front and back.

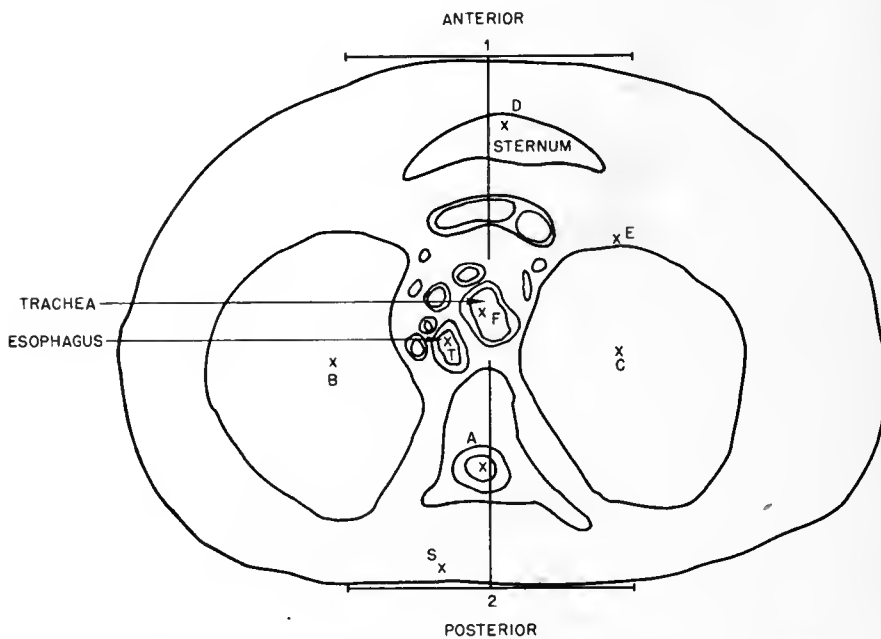

Fig. 2—Contour and dose levels at several critical areas in the treatment plan of patient illustrated in Fig. 1. Dosages to the various points are as follows: spine (A), 7000 r; lung (B), 5340 r; lung (C), 5600 r; sternum (D), 6800 r; periphery of lung (E), 5800 r; trachea (F), 6150 r; skin (S), 7000 r; esophagus (T), 6000 r. Note that, although the tumor received 6000 r in six weeks, the cord, sternum, and skin exceeded that dose.



Fig. 3—Posttreatment radiograph of case 1. The excellent radiographic response was reflected in dramatic clinical improvement.



(a)



(b)

Fig. 4—Case 2: (a) Characteristic radiographic appearance of a mid-third constricting squamous-cell cancer. A tumor dose of 7000 r in six weeks was given through six portals. (b) Radiograph showing posttreatment improvement.

CARCINOMA OF THE ESOPHAGUS

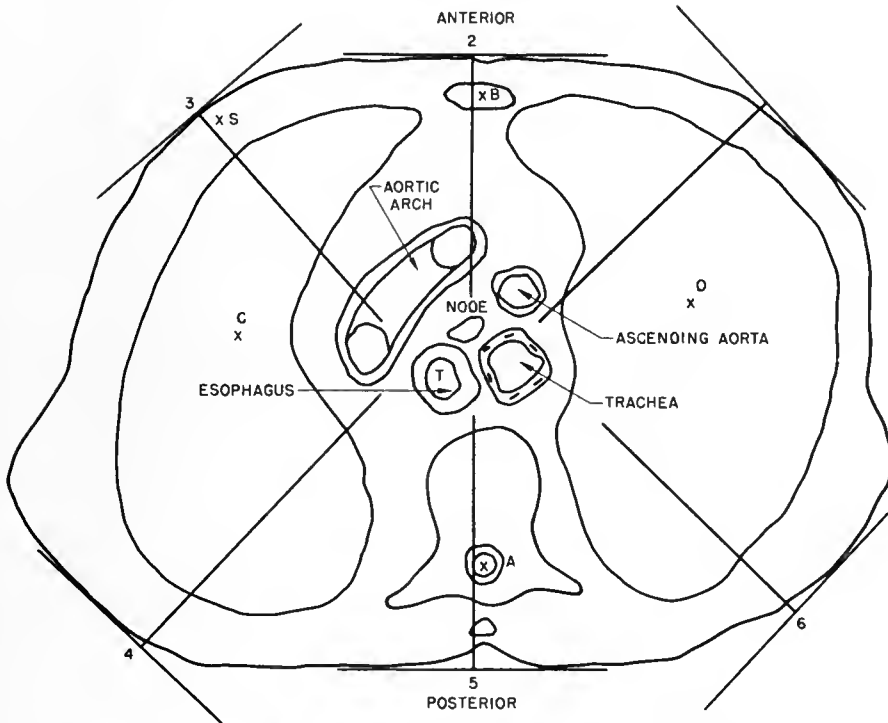

Fig. 5—Contour and dosage pattern in the critical areas of the patient illustrated in Fig. 4. With a multiple-port technique the critical regions received doses of about 4700 r or less, permitting the administration of 7000 r into the lesion in the esophagus. Dosages to various points are as follows: spine (A), 4730 r; sternum (B), 4600 r; lung (C), 3130 r; lung (D), 3550 r; representative skin dose (S), 3300 r; esophagus (T), 7000 r.

Similarly, the second patient had a carcinoma of the esophagus. He was a 43-year-old ironworker who was unable to eat solid food. Figure 4a shows the radiographic appearance of a constricting mid-third esophagus cancer with proximal dilatation; the radiograph made after treatment (Fig. 4b) shows an unusual response of the tumor. Unlike the treatment pattern of the first patient, six portals were used:

anterior, posterior, and four oblique fields, all directed toward the lesion in the esophagus. The esophagus received 7000 r; the spinal cord at that level, 4730 r; the sternum, 4600 r; the lung at point C, 3130 r, and at point D, 3550 r (Fig. 5). Obviously, a multiple-port technique permitted more satisfactory dosimetry than an anterior-posterior cross-fire technique.

Lymphangiosarcoma in a Lymphedematous Arm

CHAPTER 58

Granville W. Hudson

Vanderbilt University Hospital
Nashville, Tennessee

I wish to illustrate treatment at a 30-cm distance, i.e., treatment with the cone of the conventional teletherapy Barnes unit in contact with the patient's skin.

This case is a lymphangiosarcoma occurring in a postmastectomy lymphedematous arm. In 1948, F. W. Stewart and Norman Treves first described the clinical entity of lymphangiosarcoma in the postmastectomy lymphedematous arm and described six cases. Since that time a total of 12 additional cases have been reported. In these cases edema of the arm developed immediately or soon after mastectomy, followed in a period of 6 to 24 years by the appearance of purplish-red or cyanotic lesions of the arm.

G. F. Froio and W. G. Kirkland have tabulated the course of events, indicating that the lesion has the following very definite pattern:

1. History of radical mastectomy with or without radiation.
2. Onset of lymphedema, usually immediately or within the first year.
3. Duration of lymphedema up to the time of appearance of the ecchymotic lesion, averaging 10 to 12 years (the shortest time being 6 years, and the longest, 24 years).
4. Appearance of single ecchymotic areas (they may also be multiple).
5. Ecchymosis developing a deeper purplish hue, with beginning induration. Surface vesicles also may be present during this phase.
6. Further induration and ulceration of the lesion, which has a reddish-brown encrusted appearance, surrounded by an area of redness.
7. Still further induration of the lesion, which has a nodular feel. Other lesions may be present in the various phases described.

On purely histopathologic criteria, postmastectomy lymphangiosarcoma resembles Kaposi's disease. Without any additional clinical history, it may be impossible to differentiate the two. However, Kaposi's disease is a systemic disease, occurring most frequently in the lower extremities in males. The lesions

are, as a rule, multiple and bilateral. The prognosis of the duration of the disease is difficult. On the other hand, lymphangiosarcoma in a postmastectomy lymphedematous extremity is not a systemic disease; it occurs in the upper extremities on the side of the radical mastectomy, approximately 10 to 12 years after surgery. The lesion may be single or multiple in the affected extremity.

Froio and Kirkland stated that, in two-thirds of the cases of lymphangiosarcoma, pulmonary metastasis later appeared. From the study of these cases it is apparent that deep vein invasion occurs early, expediting pulmonary metastasis.

Table 1 lists the previously reported cases and the end results. When we enter the 1950's, we find that some cases then were treated by radiation therapy. One patient is alive after two years and eight months; another died in the same year; one patient treated by radiation therapy is alive five years after treatment. Therefore, from this period, the treatment is divided about equally into surgical and radiation attempts.

The case I wish to present is that of a 64-year-old white woman who was admitted to Vanderbilt University Hospital on Jan. 9, 1955, because of nodular hemorrhagic reddish areas on the left arm and forearm. Fourteen years before admission this patient had had a left radical mastectomy for carcinoma of the breast with axillary metastases. She had received X-ray therapy, both preoperatively and postoperatively, the total dose being approximately 3600 r. The fields had included the left chest and the left supraclavicular and axillary regions.

Soon after surgery the arm became edematous. Six months before admission the patient noticed a small tender nodule on the left forearm just below the elbow, which soon became hemorrhagic. Soon other nodules appeared, involving the arm and upper forearm on the left side.

The pertinent findings consisted of marked telangiectatic areas over the treatment fields. The left arm was swollen with chronic edema. There were multiple,



Fig. 1— Multiple scattered hemorrhagic nodules over the chronically edematous arm; marked tel-
angiectatic areas over old treatment fields (January 1955, before treatment).

Table 1— ANALYSIS OF REPORTED CASES OF LYMPHANGIOSARCOMA IN POSTMASTECTOMY
LYMPHEDEMATOUS ARM

Authors	Age at mastec- tomy	Mastec- tomy, year	Biopsy, year	Treatment	Results
Stewart and Treves	42	1938	1947	Interscapulo-thoracic amputation	Presumed dead
Stewart and Treves	60	1939	1947	No further data available	No further data available
Stewart and Treves	59	1938	1947	Interscapulo-thoracic amputation	Lived 20 months; died February 1950 with metastases
Stewart and Treves	37	1938	1947	Amputation	Died after 5 months with metastases
Stewart and Treves	40	1923	1947	Interscapulo-thoracic amputation	Presumed dead; metas- tases to lungs
Stewart and Treves	50	1928	1947	X-ray therapy	Died (not stated when); metastases
Ferraro	57	1939	1948	No specific treatment	Died December 1948; metastases
McCarthy and Pack	57	1939	1949	Interscapulo-thoracic amputation	Lived 3 years, 5 months; died of metastases
Vos	41	1936	1950	Wide excision	Died June 1951; metastases
Jessner, Zak, and Rein	47	1942	1949	Amputation	Died after 4 months; metastases
Frolo and Kirkland	43	1939	1950	Interscapulo-thoracic amputation	Died; metastases
Rawson and Frank	56	1937	1951	X-ray therapy	Living after 2 years, 8 months
Hilfinger and Eberle	42	1939	1949	Interscapulo-thoracic amputation	Died after 5 months; metastases
Hilfinger and Eberle	47	1939	1948	X-ray therapy	Died in 1948; metastases
Cruse, Fisher, and Usher	53	1938	1950	Disarticulation	Died of metastases to lungs after 6 months
Marshall	66	1948	1954	Interscapulo-thoracic amputation	Died of metastases to lungs in February 1955
Bowers, Schear and LeGolvan	41	1946	1953	Interscapulo-thoracic amputation	Living after 2 years
Southwick and Slaughter	41	1940	1948	X-ray therapy	Living after 5 years



Fig. 2—Large ulcer surrounded by a hemorrhagic area, with multiple purplish elevated areas (March 1955, before treatment).



Fig. 3—Enlarged view of the ulcerated and hemorrhagic area in the arm.



Fig. 4—Six weeks after treatment; the ulcer had healed, but some discoloration remained.



Fig. 5—Extensive multiple coalescing nodules, with hemorrhage (November 1955).



Fig. 6 — Multiple large ulcerated areas in arm and forearm in addition to coalescing purplish hemorrhagic nodules (April 1956).

scattered hemorrhagic nodules over the upper arm, both anteriorly and posteriorly, with one small nodule medially over the forearm just below the elbow. In the upper arm there was a 2- by 2-cm area, the center of which was ulcerated, with an indurated portion underneath (Fig. 1). A chest film showed no evidence of metastatic disease.

Biopsy was performed Jan. 12, 1955, and the report was postmastectomy lymphangiosarcoma appearing in the chronically edematous arm. An interscapulo-thoracic amputation was advised, but the patient refused; she was discharged from the hospital Jan. 12, 1955.

By Mar. 7, 1955, a large ulcerated area had developed in the hemorrhagic zone on the anterior aspect of the left arm (Figs. 2 and 3). The skin was atrophic, with a purplish zone surrounded by a hemorrhagic area and multiple smaller areas. Between January and March the lesion had increased greatly in size. There was a large ulcer with multiple purplish elevated areas.

The patient received radiocobalt therapy, 200 r to a large area daily for a total of 4000 r. We decided to

use cobalt at skin contact because we considered it quite hazardous to re-treat through an area that was already atrophic and telangiectatic. We thought that the tissue would not tolerate further irradiation with 200-kv X rays. The small nodular areas (approximately 1 to 2 cm) were treated individually with superficial therapy, 500 r daily for a total of 4000 r to each lesion.

The areas subsided, the ulcer healed, and the patient was relatively free of symptoms except for the annoyance of a lymphedematous arm in April 1955 (Fig. 4).

In November 1955, multiple areas had appeared on the arm and forearm, with purplish elevated hemorrhagic lesions (Fig. 5). We gave 2500 r in 18 days to the arm and forearm, using radioactive cobalt at 30 cm distance. These lesions subsided slightly, and the patient was fairly comfortable.

On Apr. 17, 1956, the patient was readmitted to the hospital. The left arm and forearm were markedly edematous, the entire arm being dark purple in color. On the forearm there was a large (7 cm) irregular ulcerated area covered with a thick eschar (Fig. 6).

A similar area of ulceration was noted on the medial aspect of the upper arm. A fissured area was present, with clusters of nodules beneath the skin in the axilla; a similar nodule was present over the sternum.

On Apr. 20, 1956, a left interscapulo-thoracic amputation was done. The patient is still living.

Discussion

Friedman: What happened to the sternal nodule?

Hudson: The radical amputation went clear to sternum, removing the whole business. They took large grafts from the thigh and grafted the area from the sternum all the way around. It was a very radical radical amputation and very deforming.

You have treated a case in the past, Dr. Friedman; it was reported in the Archives of Dermatology; I was interested in the discussion since these sarcomas are not usually very radiosensitive.

Many more cases of lymphangiosarcoma are being recognized since Stewart and Treves first described the condition eight years ago. In view of these reports, every patient who has had a radical mastectomy for carcinoma of the breast and has lymphedema should be followed for prolonged periods because of the possibility of developing postmastectomy lymphangiosarcoma.

In 1955, H. W. Southwick and D. P. Slaughter reported a case of lymphangiosarcoma in the postmas-

tectomy lymphedematous arm. This patient has survived five years with irradiation treatment. There were multiple lesions on the arm, occurring on both the upper and lower parts of the extremity. Interscapulo-thoracic amputation was advised, but the patient refused surgery and was given a course of roentgen-ray therapy.

H. A. Rawson and J. L. Frank, Jr., reported a case treated with irradiation which showed an excellent clinical response to 4500 r. They felt that at least some of these lesions should be included in the broad list of radiosensitive tumors. This group is appraised by Paterson as a type, a very large portion of which can be cured locally by a tumor dose of 3500 to 4000 r delivered in a period of three weeks.

Both irradiation and surgical management have been utilized in the treatment of patients with this disease. Obviously, amputation in most cases can control the local disease, but, in the cases of Southwick and Slaughter and Rawson and Frank, this has been accomplished by irradiation. Furthermore, the majority of patients reported at this time have succumbed to pulmonary metastases. The disability and deformity associated with interscapulo-thoracic amputation cannot be underestimated.

Thus, for the initial therapeutic approach, radiotherapy can be offered as an alternative radical procedure in lesions which are reasonably well localized or in which the possibility of worthwhile palliation in advanced cases can be achieved; Co⁶⁰ may play a special role.

Carcinoma of the Urethra

CHAPTER 59

Howard J. Barnhard

University of Arkansas Medical Center
Little Rock, Arkansas

Abstract

The case reported had a result somewhat less than optimal. A review of the radiotherapy used in this urethral carcinoma emphasizes two major considerations: first, the critical nature of the dosimetry when adjacent ports are used and, second, the decrease in the skin-sparing effect of super-voltage when the beam enters obliquely.

The patient was a 61-year-old Negro woman who had been bleeding vaginally for six months. Earlier she had urinary retention, which required catheterization on several occasions, but this cleared spontaneously. At examination in December 1954, there was extensive cancer of the urethra. Large tender inguinal lymph nodes were present bilaterally, and there were leukoplakia-like lesions on both labia. The urethra was so completely invaded that the meatus was difficult to find. There was extension within the vagina almost to the cervix. The right parametrium and paravaginal tissues were involved to the pelvic wall, and there was fullness on the left side.

On cystoscopy, the bladder was trabeculated but was without evidence of tumor. A roentgenogram of the pelvis demonstrated a questionable lytic lesion to the right of the symphysis pubis. Multiple biopsies were taken in the regions of the urethra, vagina, labia, and inguinal lymph nodes, and all showed squamous-cell carcinoma.

Palliation was all that could be hoped for, but, to achieve even this, we would have to irradiate a large volume of tissue with a relatively high dose. This was a clear-cut indication for our recently acquired telecobalt unit (Keleket-Barnes, stationary type).

At the time we began treatment, we had not yet received the data that led to the isodose curves seen in Fig. 1. Consequently we were not aware that the lateral contribution in the penumbra region was so great. We wanted to treat with two 10- by 14-cm fields anteriorly and the same posteriorly, but, without the benefit of this information, we separated the fields by only 2 cm.

Isodose curves computed as though 1000 r were delivered to each of these four fields are shown in Fig. 2. The maximum is found in the area of separation between the fields, and there is a fairly rapid fall-off from this region. Figure 3 shows the same situation except that the fields have been separated by 4 cm. The distribution is more homogeneous. Except for small "hot spots," the previous 2070-r maximum has been reduced to 1440 r. The maximal zone has been moved away from the center. Nonetheless, the area of separation continues to receive an adequate dose.

Thus we started "on the wrong foot" with only 2 cm separation; it was late in the five-week treatment period when we changed to the more desirable 4-cm separation. Figure 4 illustrates the fields that were used, with both 2- and 4-cm separation; 2300 r was delivered to each of the four fields with 2 cm separation; only 800 r was administered to the fields with 4 cm separation. By this time it had become apparent that we were reaching a tolerance level in the perineum, but the inguinal lymph nodes remained large. We wanted to increase the dose to these nodes without compromising the perineum further, and therefore the oblique 8- by 8-cm fields were added; 1080 r was given to these fields, anteriorly only. Figure 5 shows the total doses at the level where the added oblique fields contributed maximally. It is apparent that the 2-cm separation held sway and there was maximum build-up in the mid-line.

When the patient returned two months after the end of radiation therapy, the perineum had almost completely healed. The nodes in the inguinal region were very small and were no longer tender. It appeared that the patient was going to do fairly well despite the somewhat inefficient therapy.

Six months after therapy there was a marked change for the worse. The entire perineum had broken down (Fig. 6), and she had a vesicovaginal fistula. Multiple biopsies showed no evidence of tumor. The suspected lesion in the region of the symphysis was no longer

CARCINOMA OF THE URETHRA

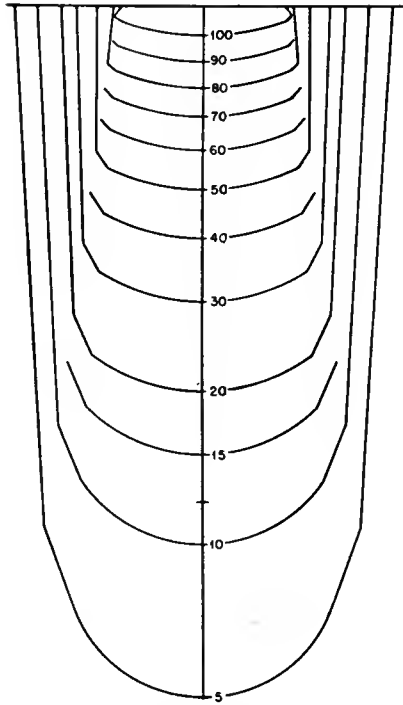

Fig. 1—Isodose curves for Keleket-Barnes telecobalt unit (9.7- by 13.9-cm portal), plotted for a 9.7-cm side at a 50-cm treatment distance. There is a considerable contribution laterally beyond the path of the primary beam. (Drawn by T. H. Oddie from ORINS data.)

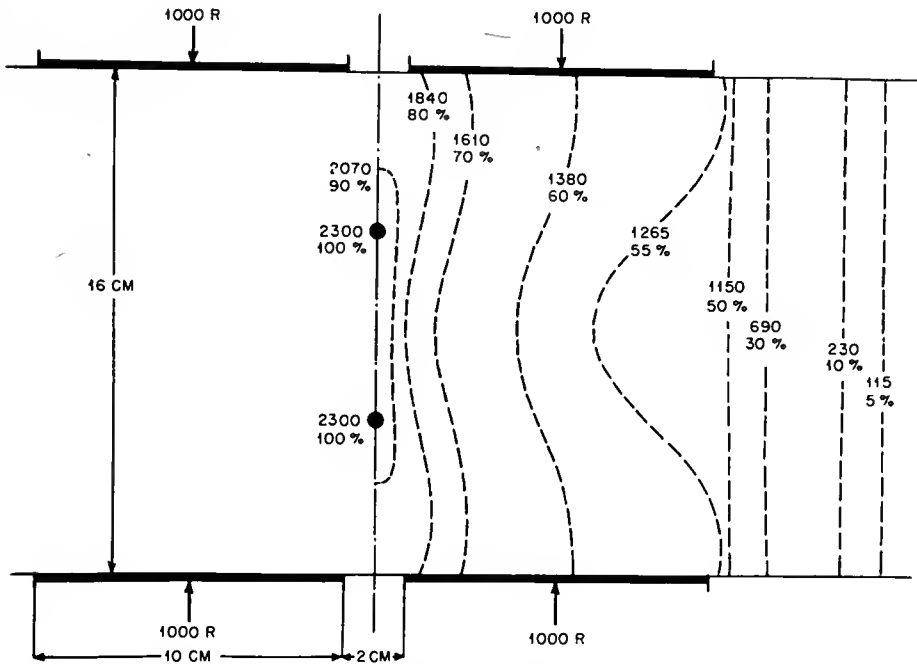

Fig. 2—Isodose curves drawn for 1000 r delivered to each of four 10- by 14-cm fields. With the 2-cm separation there is a considerable build-up in the mid-region. (Computed and drawn by Walter Mauderli.)

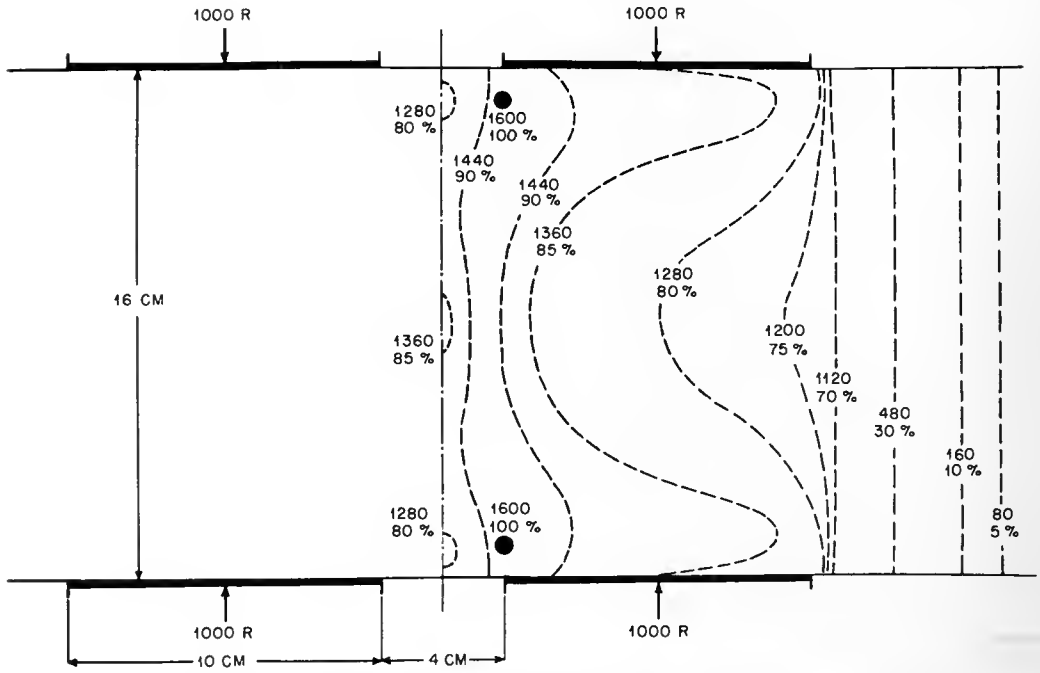

Fig. 3—Isodose curves drawn for 1000 r delivered to each of four 10- by 14-cm fields. The 4-cm separation gives a more homogeneous distribution than the 2-cm separation seen in Fig. 2. (Computed and drawn by Walter Manderll.)

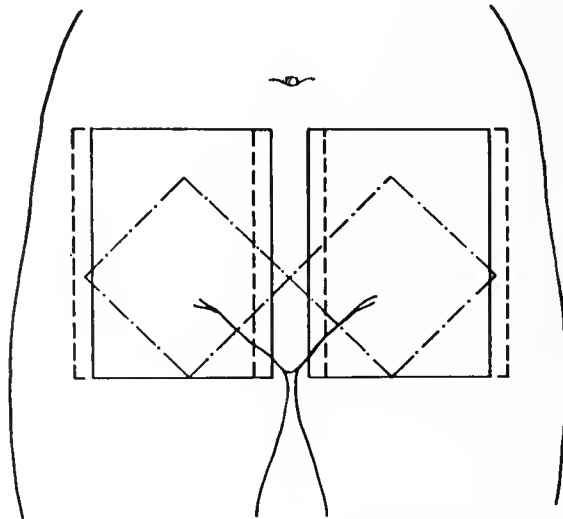

Fig. 4—Treatment fields outlined on the patient. —, 10- by 14-cm fields at 2 cm separation. - - - -, 10- by 14-cm fields at 4 cm separation. - · - · - ·, 8- by 8-cm fields used anteriorly only.

CARCINOMA OF THE URETHRA

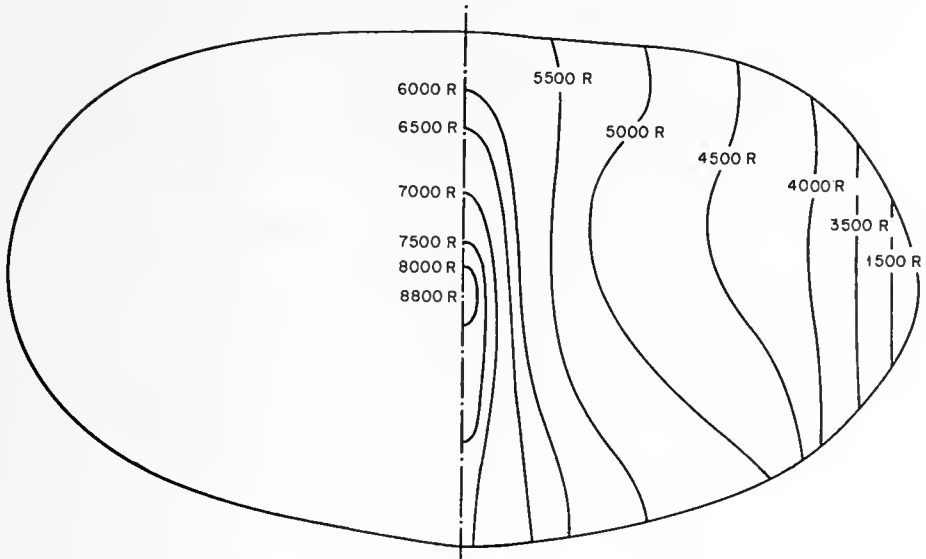

Fig. 5—Cumulative isodose curves at the level where the added oblique fields contributed maximally. There is a build-up in the mid-line, which clearly indicates that the 2-cm separation of the fields predominated. (Computed and drawn by Walter Mauderli.)



Fig. 6—Six months after therapy. The perineum had broken down, and there was a vesicovaginal fistula.

visible on the roentgenogram. Remarkably, she was not particularly uncomfortable, and she refused any attempt at surgical intervention. At this time (March 1957, two and one-fourth years posttherapy), she remains alive and relatively unchanged.

In conclusion, the use of adjacent portals involves

critical isodose relations that make the single larger field more desirable. The skin-sparing effect of supervoltage is reduced when the beam enters obliquely because ionization equilibrium is brought closer to the surface. In the case presented, this effect was heightened in the radiation-sensitive perineum.

Advanced Gastrointestinal Carcinoma

CHAPTER 60

Samuel L. Balofsky

Wayne State University College of Medicine
Detroit, Michigan

This is a report on the use of Co⁶⁰ teletherapy in the palliation of 45 patients with advanced gastrointestinal tract disease during the past 18 months.

It has long been the opinion of radiotherapists that, although adenocarcinoma of the gastrointestinal tract may present variable degrees of radiosensitivity, they are in general not radiocurable. Unfortunately, irradiation of the abdomen with 200-kv X rays often causes symptoms of a more severe nature than those for which relief is sought. The ability of supervoltage irradiation to decrease skin reactions and radiation sickness prompted us to treat a patient with inoperable anaplastic carcinoma of the head of the pancreas. After treatment he improved rather noticeably. He tolerated treatment well and even played nine holes of golf on the last treatment day. He subsequently enjoyed six months of asymptomatic and apparently normal life and then succumbed to pulmonary metastases.

Similar early experiences with carcinoma of the large intestine led us to be rather hesitant in rejecting patients because of massive disease.

Almost all the 45 patients to be presented had massive local disease with or without regional or distant metastases. Many had lesions that were nonresectable when first seen, and an even larger group had post-operative recurrence.

Table 1 shows the location of the lesions, the average dose given, the number that were palliated, and the number having radiation reaction. Thirty patients (67 per cent) were palliated to a greater or lesser extent. Sixteen patients who experienced radiation reactions of some degree show no correlation with the degree of palliation.

Figure 1 indicates graphically the degree of palliation obtained in the series of cases. The bowel series is the only one sufficiently large to be of any significance, and it is seen that one-half received minimal or no palliation. Thirty-eight per cent were palliated to a degree classified as moderate or good. The remaining 12 per cent were placed in an indeterminate

group because these patients had no definite symptomatology that could be evaluated at the onset of therapy. They did do better for longer periods of time after treatment than would ordinarily be expected, considering the extent of their disease.

Table 1—TREATMENT RESULTS FOR ADVANCED GASTRO-INTESTINAL CARCINOMA

Location	No. of patients	Average dose	No. palliated	Radiation reactions
Large bowel	26	5000 r/5 weeks	20	6
Stomach	9	5000 r/6 weeks	5	4
Pancreas	6	5000 r/6 weeks	2	1
Biliary	4	5000 r/6 weeks	3	3
Total	45		30 (67%)	16 (36%)

The symptom most commonly encountered in this and the other groups was pain. Table 2 shows that 77 per cent of the bowel patients had pain as a subjective complaint. Seventy-five per cent of these patients received some, frequently minimal, relief of pain after Co⁶⁰ teletherapy.

Table 2—LARGE-BOWEL CARCINOMA IN 26 PATIENTS

	No. of patients	Percentage
Pain as a presenting symptom:	20	77
Relief of pain after Co ⁶⁰ :	15	75

Again, in Fig. 1, it is noted that 50 per cent of these patients received minimal or no relief following irradiation. However, although no definite symptomatic relief was obtained, we feel that obstruction was prevented in two instances. Bleeding was halted in one patient who had been classified as receiving moderate palliation. There was excellent regression of tumor, and the patient was able to return to work for several months. He survived six months, twice as long as the average for the group, in spite of a disease

of the same type and extent as that present in most of the other patients.

We have treated six patients with carcinoma of the pancreas and four with carcinoma of the biliary tract.

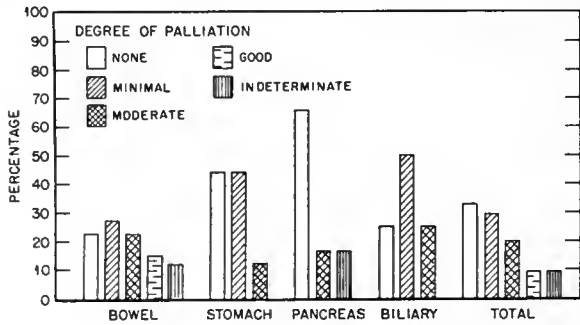

Fig. 1—Graph showing palliation obtained with Co⁶⁰ teletherapy in 45 patients with advanced gastrointestinal carcinoma.

The value of roentgen therapy for advanced carcinoma of the pancreas was first demonstrated by G. E. Richards in 1922. Little has been written on the subject in recent years. We had some success in two of the six patients. One was discussed previously; the other, our most recent case, a patient with very extensive local disease, completed therapy four months ago and continues to feel well and to gain weight.

Improvement after irradiation was noted in three of the four patients with carcinoma of the biliary tract. However, two of these were palliated only minimally. The average duration of life in these two groups was 5 months after therapy; for patients with carcinoma of the bowel, it was 5.5 months, and of the stomach, 3.1 months; the average for the entire group was only 4.6 months. Figure 2 shows graphically the survival times after treatment.

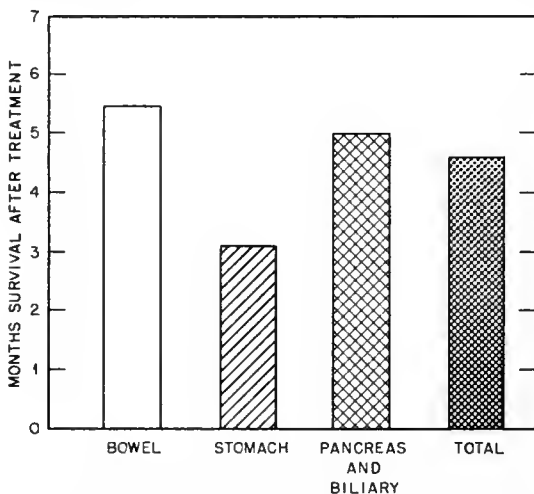

Fig. 2—Graph showing survival times after Co⁶⁰ teletherapy to 45 patients with advanced gastrointestinal carcinoma.

As was expected, the natural course of the disease was not altered, and the patients who were palliated

did not necessarily live longer than those getting no relief at all. Of the entire group 62 per cent were palliated not at all or only minimally. Considering this and the fact that the average life duration after treatment was only 4.6 months, it becomes necessary to investigate the frequency and severity of radiation reaction. It would indeed be a sorry state if we were causing more distress than comfort with teletherapy.

Examination of Fig. 3 reveals that radiation reactions were remarkable only by their absence. Ninety-one per cent of the patients experienced minimal or no symptoms due to therapy. In no case was it necessary to discontinue treatment because of intolerance to irradiation. Only 9 per cent had reactions of moderate severity, and these reactions were usually well controlled by simple medication. In a few patients it was necessary to decrease the daily dose rate temporarily while reactions were brought under control.

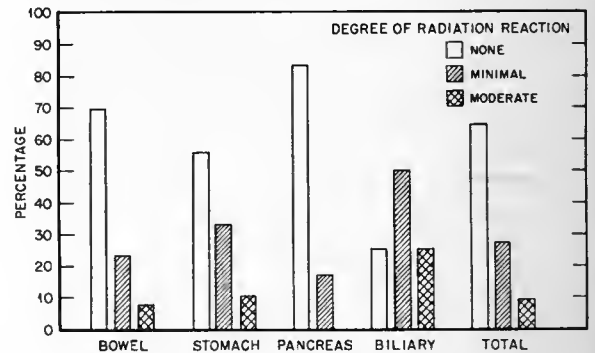

Fig. 3—Graph showing degree of radiation reaction in 45 patients with advanced gastrointestinal carcinoma after Co⁶⁰ teletherapy.

Considering the entire group it will be difficult to say with assurance that more than one-third of these patients derived any benefit from irradiation. This figure includes all cases classified as minimal palliation, as well as those designated as indeterminate. It is our feeling, however, not only that many patients were significantly benefited but also that complications were frequently prevented.

Evaluation of minimal degrees of palliation was most difficult in the absence of adequate control groups because of the marked psychological reactions of some patients to cobalt therapy. A more prolonged study of a large group of patients is needed for final evaluation of this method of radiation for palliation.

Some of our surgeons were favorably impressed with the apparent relief of symptoms and improvement within this group of patients. As a result we were able to treat three patients preoperatively. They were operated on approximately four weeks after completion of radiotherapy. The pathologist's evaluation of the surgical specimens is of interest. There was no evidence of radiation change induced in the tumor of one patient, although radiation changes were noted in the submucosal lymphoid and vascular tissues. It was demonstrated radiographically and by direct observa-

tion that this patient had 25 per cent decrease in the size of the rectal mass. The second patient showed no microscopic evidence of change within the tumor. However, there was vesiculation of cells in the areas of lymphatic permeation, and viability of these tumor cells appeared to be reduced. The size of the tumor definitely decreased. The third patient showed decrease in the size of the tumor, and there was no demonstrable microscopic evidence of radiation effect.

In conclusion, Co⁶⁰ teletherapy provides a super-voltage modality for the treatment of lesions of the gastrointestinal tract without disturbing side effects. Only palliation should be expected. In this series of 45 cases, moderate or marked palliation was obtained in 30 per cent of the patients.

Relief of pain occurred in 75 per cent of the patients with complaints of pain. In general, the results were best in carcinoma of the colon and rectum.

DISCUSSION

CHAPTER 61

Ellis: In reference to Dr. Rubinfeld's paper, we try to pass a polyethylene tube and give the patient a liquid diet, which consists of a pint of milk, four eggs, 4 oz of butter, and 4 oz of sugar a day.

If we cannot pass a polyethylene tube, we should have a gastrostomy. I think there is a risk in just watching the patients. The danger sign is an increased rapidity of the pulse. At this stage the patient is becoming too weak.

Isherwood: We have been treating carcinoma of the esophagus for a long while with 250 kv and with supervoltage. Why do we use such high doses? Why do we not stop short of 6000 rads for palliation? The tumors do recede, and the patients live for months. Then there is a second chance to help them, for a longer period of time.

Smedal: I have had no definite opinion about what to do for every case. Sometimes I wish we would do a gastrostomy on each one and spare the patients from becoming worse and starving while they are being treated. Most of them lose weight; if they had a gastrostomy, they would be in much better condition throughout the therapy.

We have tried inserting a polyethylene tube. One woman had a tube down for three months, and she did very well during the therapy because she maintained adequate intake. The intake is usually below normal. I do not see how a patient can be expected to react normally when he is not getting proper fluid or nourishment. I should rather perform gastrostomy.

On the question of palliation which Dr. Isherwood brought up, I do not understand why, if you are going to treat a short segment of the esophagus, you do not just admit that you are going to merely palliate the condition and treat a short segment by rotation, at the same time avoiding the spinal cord. With the middle third, certainly, you can rotate, using a small field, and not spill anything into the lung fields, and you can palliate with a small dose.

If you are going to treat for a cure and include the lymphatics in the field, you would have to treat the whole esophagus, the celiac axis, and maybe the parasplenic nodes. Otherwise you might just as well take a small field and treat it to a palliative dose.

Freid: About re-treating patients, especially if the dosage for the first course was adequate, if long-term palliation was not achieved the first time, a second course will also fail. There is great danger of mediastinitis and postirradiation fibrosis of the mediastinum from a second course of irradiation. Fortunately, many of the re-treated patients die before the postirradiation fibrosis develops.

Friedman: I should like to discuss another point which Dr. Rubinfeld mentioned: port films taken by means of supervoltage roentgenography. With the Van de Graaff 2-Mv X-ray machine, some beautiful films have been taken. With our 2-Mv resonant transformer the films have been equally good. Somewhat better films have been achieved with the Walter Reed Hospital 1-Mv resonant-transformer X-ray machine.

Most of the films taken with Co⁶⁰ are poor in quality; however, the best supervoltage roentgenographic film that I have ever seen was taken in Pittsburgh with a Co⁶⁰ hectocurie unit.

I want to ask Dr. Bruker how that excellent film was obtained with cobalt.

Bruker: The cone had a pinhole in it. The main reason for the poor quality of most films is the 2-cm-diameter focal spot used at 50 to 70 cm distance.

You can make a pinhole (like the one shown in Fig. 1), a 1-mm pinhole that provides the equivalent of a 2-mm focal spot. This produces a much better film. The resolution is almost reasonable.

Friedman: Yes, but we have, or we thought we had, demonstrated to ourselves, and E. P. Pendergrass of Philadelphia came to the same opinion, that the size of the focal spot did not influence the quality of the picture, an observation that surprised everyone.



(a)

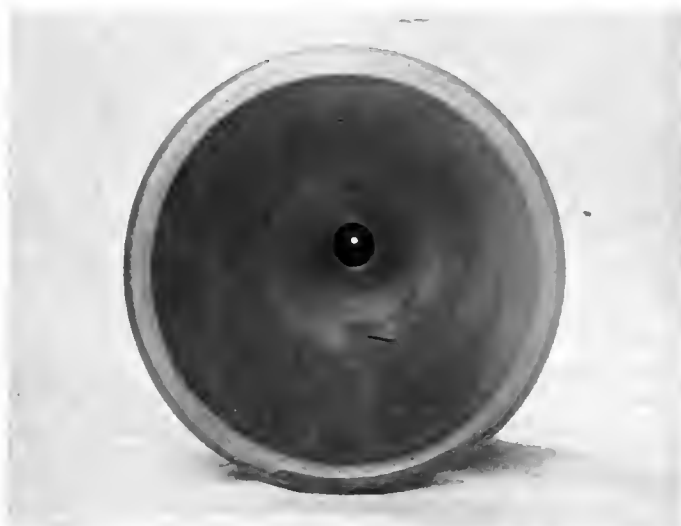

(b)

Fig. 1—(a) Side view of the pinhole cone used in the ORINS prototype Co^{60} hectocurie unit; (b) front view of the cone.

Brucer: You would have to define what you mean by the word "quality."

Friedman: I mean sharpness of detail.

Brucer: At a long distance this is true, but, with the focal spot at 50 cm, the size of the pinhole certainly will make a big difference. Remember, we cannot use Bucky grids or other devices to sharpen a picture with Co^{60} as we can with low energy.

The pinhole is difficult to construct. It takes a piece of tungsten 6 in. long and with a very long pinhole.

Friedman: It may be difficult to construct, but a good

one must be constructed. I do not see how one can perform supervoltage radiation therapy, delivering large tumor lethal doses deep into the body, without port films.

We average two to four port films before starting treatment. Thereafter, intermittently during treatment, additional port films are taken. I suggest that further thought be given to this with respect to cobalt units.

Brucer: I wanted to make sure that the Keleket-Barnes representative would be here because he said a long time ago that his company was planning to put these on the market. It is a simple attachment and is relatively cheap.

Freid: Most of our patients are filmed several times during the period of treatment using our Co^{60} source as the X-ray tube. Films are taken at the onset, at the halfway mark, and at the completion of irradiation to verify the portals under treatment.

These films are not always technically good, but they are readable. I believe there is much room for improvement as far as technique is concerned.

Bruce: Let me exaggerate this in a diagram (Fig. 2). When you make a very short pinhole, the edges of the pinhole are very thin. Therefore the cobalt beam

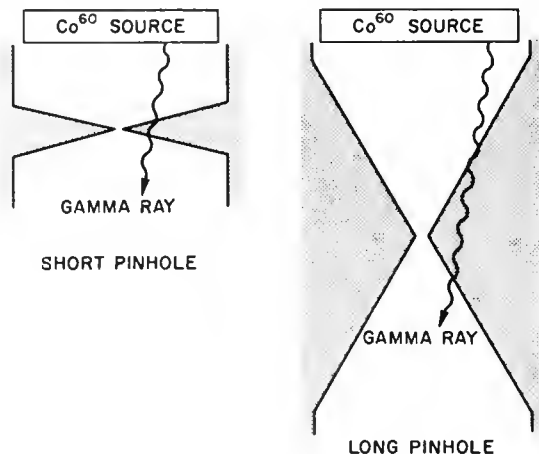

Fig. 2—Diagram comparing radiation protection in a short pinhole with that in a long pinhole.

comes through the edge of the pinhole; actually, in so far as the million volt radiation is concerned, the pinhole is much larger than it appears visually. However, when you make the pinhole very long and the sides of the opening are at a very obtuse angle, the edges of the pinhole are not so thin. The actual pinhole for million volt radiation is never perfect, but it is better when made with a very long piece of metal than with a very short piece of metal. Once properly designed, pinhole cones are easy to make, and they can fit most of the current cobalt machines very handily. Another very important point is the type of film that is used. We have found the Kodak type "M" film to be the best.

Lofstrom: Although I think this will only confuse the record, one point I made earlier was that those of you who may have the Keleket-Barnes unit without a diaphragming device might try, with your radiographic unit, to determine whether or not the therapy cone will fit into the housing that supports the radiographic tube.

In ours it just happens to fit very snugly. We get excellent demarcation and much better radiographic exposures than can be obtained with the cobalt primary-source energy.

Barnhard: Does the focus fall at the same point?

Lofstrom: It just happens that it is exactly the same

point, from the focal spot of the tube to the surface of the coning device.

Lolonne: Would it not be possible to put in a matching source for X-ray diagnosis, on machines which have a cylinder, for instance, supporting the source? The source for X-ray diagnosis, such as thulium, could rotate in the place of the source.

Bruce: Stanley Clark, at the Cedars of Lebanon Hospital, did just this. He used a thulium X-ray source. However, it has such a short life that it became a bother; and, instead of using the thulium, he put an 80-kv diagnostic dental X-ray machine right next to the cobalt machine.

May I talk about something that is not available yet? Before long Eu^{155} can be made available in reasonably large quantities. With this you might have a source that approaches the energy of the thulium source; however, it will have a half life of almost two years. This, theoretically, would make an almost practical source for the opposite end of one of the Co^{60} machines. A 25-year practical source of 80-kev radiation is now being made.

Smithers: You have been talking about the effects of radiation in the treatment of cancer of the esophagus, which is a very interesting subject. The esophagus is a thin-walled tube. It begins at a rather indeterminate place, where there is a slight constriction due to the pull of the cricopharyngeus muscle but where the mucous membrane on either side is much the same. It ends at the cardia, where the mucous membrane changes from squamous to glandular in a most irregular manner in relation to the cardia. The tumors of the esophagus and their response to treatment are quite different, depending on whether they occur high or low or whether they are in an esophagus lined by squamous membrane or in one lined by gastric mucous membrane.

If you look at the world literature and add up all the people who have ever claimed to have a patient with carcinoma of the esophagus who lived five years after treatment, you will not find very many; but you will find the tumors most interestingly distributed along the length of the esophagus.

If you plot them—upper third, middle third, and lower third, arranging the surgical survivors on one side and the radiotherapy survivors on the other—you will find that the surgeons' claim of success is primarily at the bottom end, and the radiotherapists', at the top. There is little to show for success in the middle part of the esophagus (Fig. 3).

What is really of interest is that the adenocarcinomas of the lower end of the esophagus have a comparatively good prognosis with surgery; whereas radiotherapy has accomplished little in this area. Radiotherapy is less effective here because it does not cope with the spread below the diaphragm, but it is the best method for the upper third and probably for the middle third as well.

Rubinfeld: In contrast with the views of Dr. Smedal, I strongly oppose gastrostomy in carcinoma of the

esophagus. My experience has been that, once the opening into the stomach is established, the patient goes downhill much faster. It may be due to the severe changes that take place in the body chemistry with the loss of gastric juices and hydrochloric acid.

SITE	TREATMENT	
	SURGERY	RADIOTHERAPY
UPPER THIRD	2	33
MIDDLE THIRD	7	15
LOWER THIRD	65	13
TOTAL OF 5-YEAR SURVIVORS	74 (COMBINED-TREATMENT CASES OMITTED) 64	

Fig. 3—Graph showing relative effectiveness of surgery and radiotherapy in treatment of carcinoma of the esophagus.

Dr. Isherwood, I think one would be held remiss if the magic 6000 r were not delivered into a squamous-cell epithelioma. Were I to report a dose of only 3500 r before an erudite audience like this, criticism would be sharp.

With due respect to Frank Ellis, we think of the magic 6000 r over a four- to six-week period as necessary to achieve either lethality or palliation. Attempts should be made, therefore, to reach this dose-time level.

I have a different concept about carcinoma of the esophagus. I think that the basic anatomy, namely, the thin wall, permits early dissemination. The remarks made about spread beneath the diaphragm represent terminal patients. It is more likely that the early esophageal lesion spreads laterally to infiltrate quickly the thin muscularis.

Ellis: I do not agree that it is the thin wall of the esophagus that leads to the dissemination. I think the lesions that disseminate rapidly are lesions of muscular structures, and the esophagus is a muscular structure; the same thing applies to the extrinsic larynx, the palate, and the tongue; I believe that the muscle, continually moving, massages the cells in the vessels and lymphatics.

With growths that are on nonmuscular structures, such as the alveolus and hard palate, the intrinsic larynx, or the antrum, metastases do not occur so quickly.

Friedman: Lymphangiosarcoma in an edematous arm is moderately radiosensitive and should be treated primarily with radiation. Originally I hesitated to irradiate these lesions vigorously because I usually found the situation Dr. Hudson described; but now I disregard this and irradiate not only the lesion but also the entire arm, including areas slightly beyond the edematous portion.

With supervoltage radiation and two opposing fields, I have been delivering a tissue dose ranging from 4000 to 5500 rads in four to six weeks.

In the last patient I treated, the edema subsided so that the arm was less swollen than it had been for the entire preceding 15 years.

Freid: How many cases have you treated?

Friedman: Four cases, one successfully for nine months.

Freid: Lymphangiosarcoma does not as a rule respond to radiotherapy, nor is it amenable to surgery. Our experience with this entity dates back to a period before the Treves report. A patient on our service had tremendous lymphedema of the arm. The surgeons anastomosed the arm to the chest wall in an attempt to decrease the lymphedema. This procedure was unsuccessful, and the patient later developed a lymphangiosarcoma of the edematous arm. Amputation was of no avail, and she died shortly afterwards. Another patient treated solely with irradiation also did poorly.

Hudson: I should like to ask Dr. Brucer a question: Do you think it is necessary to have a cadmium filter when you treat at contact?

Brucer: The original study we published on that problem with Jasper Richardson showed that the cadmium filter was absolutely necessary. Then J. L. Haybittle from Cambridge wrote to me and showed that our study was correct in so far as we went; but there was a further extension to the problem, showing that the filter was necessary only under certain conditions.

But these are facts, and facts never answer any questions. Dr. Simon made some practical measurements. He removed the filters that we had on the machine, treated the patient, and found that he obtained just as good results. The facts as we measured them are still perfectly correct; however, they do not seem to have any bearing on the practical problem. I think Dr. Simon has shown that these filters are not necessary from the standpoint of short-term results. Even more recently Dr. Simon has observed his longer term results. It appears that the filters are necessary after all. The filters do not have to be cadmium. Any medium-weight metal will do.

Farmer: It is not quite clear to me why Dr. Barnhard divided his field into two rather than using one larger field if the object was to get a uniform dose distribution.

Barnhard: Perhaps this may be attributed to ignorance as much as to anything else; this was probably one of the first five patients we treated. We had the option of either treating with the available cones two adjacent fields or backing off to a greater distance and having a very low roentgen flux.

Ellis: This looks like radionecrosis, does it not?

Barnhard: That is putting it bluntly. We fear that it is, and we accept the responsibility for its being that. Actually, the disease was so extensive that we do not know whether to place some of the blame on the extensive malignancy itself.

Ellis: It looks typical of radionecrosis to me. Concerning the question of two fields together, I had a technique for treating the pelvis for carcinoma of the cervix with X rays in 1933. After using it for a little while, it became obvious that the technique was very sensitive, both to the distance between the fields and to slight tilting; both factors can make a terrific difference in the dose to the mid-line. It is too sensitive to use clinically because one can make too many mistakes with it.

Benner: In such cases, when it is difficult to place two fields properly beside each other, avoiding overdosage or underdosage in the central zone, the penumbra, usually considered undesirable, may be of real value. If two fields having a wide penumbra (dose distributions like A and B in Fig. 4) are properly

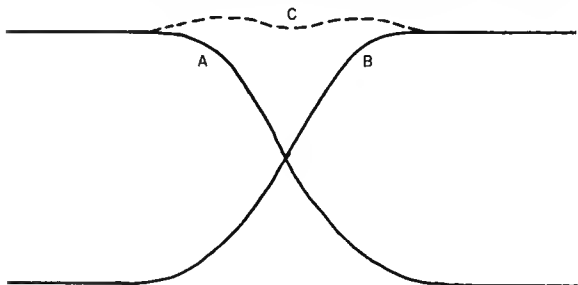

Fig. 4—Dose distributions for two fields having a wide penumbra.

combined, the resulting dose distribution (C) is rather even, and the exact distance between the fields is not very critical.

Lofstrom: I think we have seen a broad cross sec-

tion of dosimetry. I wondered why the diagonal ports were used, after the decision to move them 4 cm apart, bringing the ports back together again, with the same penumbra and consequence of overlap in the deeper area.

Barnhard: The ports were used because they fit most conveniently over the inguinal regions. We were not too concerned about their overlapping angles because only a small volume of tissue would be involved. Remember that I presented this as a bad case. I do not condone the procedures used.

Friedman: May I comment on an aspect of Dr. Balofsky's presentation? A number of stomachs and intestines have received tissue doses of 5000 rads. If one million volt X rays, half-value layer (HVL) of 3.6 mm of lead, had been used, there should have been approximately 20 per cent radiation injuries of the normal stomach and bowel.

In this instance, with radiation from Co^{60} with an HVL of 11 mm of lead, 5000 r was used, and no radiation injuries are reported.

Therefore it is probable that this radiation is biologically less effective, unit for unit, than the softer radiation from one million volt X rays, which leads me to make my own concluding recapitulative remark of this seminar, that the units employed in supervoltage radiation are neither roentgens nor rads, but riddles.

Ellis: Do you think enough time was allowed after the treatment for injury to develop?

Friedman: No, but I wanted to make the wisecrack.

Lofstrom: I think that, basically, in the treatment of the majority of these patients, sufficient time for injury was not anticipated, although there are two or three of them who have gone on for quite a period of time, well beyond the period reported, and have still shown no signs of significant damage.

PART

SPECIAL TALKS

5

Section
M

General Considerations

Howard B. Hunt
and
Carl B. Braestrup
(presiding)



Legislative and Professional Controls of the Use of Radiation

CHAPTER 62

Wendell G. Scott

Department of Radiology
Washington University School of Medicine
St. Louis, Missouri

We all realize that the legislative and professional control of the use of radiation is a serious problem; we read about it in the newspapers, we see articles about it in our national magazines, and now the word in every household is that radiation can be hazardous and that we must be protected from it.*

When Dr. Brucer asked me to talk about this problem, I felt that I was pretty much "out in the woods." Finally, I decided to present it from the viewpoint of the practicing radiologist who will have to obey all regulations that are made and who must earn the money and pay the bills for whatever is necessary to fulfill such provisions.

To understand the possible need of legislation for protection from ionizing radiation, one must comprehend the tremendous increases in the use of atomic material, the profound changes they have wrought in the Armed Forces, the great potential of atomic power for the production of electricity, the widespread utilization of radioactive material in industry and medicine, and the considerable increase in the number and use of roentgenologic procedures.

It is said that the most important application of atomic energy in industry will be the generation of nuclear power. In February 1955, the British Government authorized the building of 12 nuclear power stations to be completed by 1965. These stations will produce about 2000 Mw of electricity, or about 10 per cent of their total production. By 1975, about 40 per cent of their electricity will be produced from this source, which will do the work of 40 million tons of coal per year.

In this country we can expect similar advances on even a greater scale, although now it looks as if it will not displace the fossil fuels but will supplement them on an economically competitive basis. Actually, the Gore Bill provides for an appropriation of 400 million dollars for the building of nuclear reactors at all AEC installations, and just recently it was passed by the House of Representatives.†

The Navy is in the process of converting oil-powered

ships to nuclear power, a more startling revolution than the conversion from sail to steam. The Air Force has already authorized the development of the first nuclear-power planes. The Armed Forces have the "new look" with their atomic weapons. Think for just a moment of the thousands and thousands of people required to make these conversions, to manufacture the equipment, and to maintain and operate it. Yes, times have changed.

The preatomic age ended just 14 years ago, at a time when all the radioactive material in the world under man's free control was about 3 lb of radium. Today, at a single atomic project, there may be radioactive materials equivalent to millions of pounds of radium, and these would not be of one kind, but of hundreds, comprising almost every known element.

In the atomic industry at that time, there were a few radium-dial painters doing standardized work and an occasional operator of an industrial radiographic unit. Today thousands of workers perform hundreds of tasks in the vicinity of materials releasing much more radiation than man had ever coped with. Instead of several thousand doctors, radiation physicists, and technicians who handle relatively minute quantities of radium and X-ray equipment ranging from 80,000 to one million volts, there are now thousands of scientists and technicians working with many radioactive materials and treating patients with high-voltage equipment that produces tens of millions of volts.

All these vast developments have been accomplished with an amazing safety record. Over an 11-year period, two people have died of radiation injuries; neither was caused by reactor operations. Other injuries, caused by the usual types of industrial accidents, have caused 184 deaths. This is a truly magnificent tribute to the radiation and health physicists, the radiologists, physicians, industrial health engineers, and many

*This material was written more than three months before the release of the report on the Biological Effects of Atomic Radiation by the National Academy of Sciences.

†It was later defeated in the Senate.

others responsible for the safety and welfare of the atomic worker; all this has been done without the enactment of legislation for controls and directions.

Until a few years ago all atomic energy was almost exclusively a matter of the Federal Government. The secrecy and paramount requirements of the defense program made it so, but, with the practical application of the peacetime uses of the atom, this is no longer possible. The state and local governments will have to participate in the growth of this vital power and assume a responsibility for what happens in the future.

For example, states will want to encourage and promote atomic industrial development, and their departments of industrial development will become active in this field. The public utilities commissions will have to wrestle with important questions in the areas of corporate financing, financial responsibility, and rate schedules for the power companies. The public health departments, industrial safety departments, and the environmental sanitation departments will have to meet problems of radiation protection.

It is clear that the release of atomic energy to private industry will produce a host of problems at the national level, at the state level, and at the local level. It is just as clear that a high order of cooperation and uniformity of controls among all levels of government is essential and that legislation will be necessary to ensure the necessary protection and to avoid confusion and even chaos.

The Federal Government was faced with the problems of how to release this huge stockpile of experience and information to industry—how to release, for peacetime use and development, quantities of radioactive materials that could be harmful and even dangerous to large groups of the population. Obviously, Congress had to set up the rules, and legislation became a necessity.

The first national legislation enacted on this subject was the Atomic Energy Act of 1954. This Act removed the legal barriers upon private activity in the field of atomic energy, provided for considerations of national defense and security, established standards for safety of the public, and required regulation of the newly authorized private activities.

To accomplish these purposes, Congress provided for a comprehensive system of control by the United States Atomic Energy Commission, to be administered by the Division of Civilian Application, over the material and facilities essential to industry. These controls are imposed by the prohibition of the private possession and use of these materials and facilities without a license from the AEC and by the requirement that licensees observe such regulations and orders for the control of their activity as may be issued by the AEC.

The materials for which licenses are required are designated in the Act as special nuclear material, source material, and by-product material. Special nuclear material consists of U^{233} , uranium enriched in isotope 233 or 235, plutonium, and any other ma-

terial that the AEC determines, pursuant to the statute, to be special nuclear material.

Source material includes natural uranium and thorium. Although special nuclear material is by law the property of the Government, the private ownership of source material is permitted under the Act.

By-product material, more familiarly known as radioactive isotopes, covers only those radioactive isotopes produced in nuclear reactors. Naturally occurring radioactive material, such as radium, and radioactive material produced in particle accelerators are not by-product materials and are not subject to regulatory control by the AEC.

Similarly, radiation produced from machines, such as X-ray equipment, is not subject to control by the AEC. Actually, radiation from such sources is not subjected to any legislative control whatsoever. This is a most unfortunate situation, as emphasized by the fact that the only sentence that is in italics in the new Bureau of Standards (NBS) Handbook 61 on regulation of radiation exposure by legislative measures reads, and I quote: "It is our strong conviction that any radiation control act should provide coverage for all kinds of ionizing radiation, regardless of source; to do otherwise is only to invite confusion and conflict."

The health and safety provisions of the AEC regulations are not directed against the usual hazards associated with normal industrial activity; they are directed essentially to those risks peculiar and unique to source material, special nuclear material, and by-product material. They are directed to the protection of workers within a plant, as well as to the protection of the public outside the plant.

The fact that the AEC could not include radium, X ray, and particle accelerators in their system of controls and regulations was a circumstance that provided a key for the opening of multiple standards for levels of permissible radiation and for controls on radiation protection, particularly in the field of medicine.

For example, the development of legislation embodying different standards of permissible levels of dosage and protective barriers for governing the users of Co^{60} teletherapy and other forms of supervoltage therapy would produce a serious degree of confusion among the physicians, the architects who design the buildings, and the manufacturers of the various kinds of equipment; it would also provide a rich field for the not-so-scrupulous personal-injury lawyer.

A uniformity of standards applicable to all groups of people affected by radiation is of the utmost importance; otherwise, every group will have its own recommendations. There could be recommendations of the International Commission on Radiation Protection (ICRP), the National Committee on Radiation Protection (NCRP), the AEC, the United States Public Health Service, the United States Veterans' Administration, the Armed Forces, the International Labor Organization (ILO), the American Federation of Labor, the Congress of Industrial Organizations, and others.

Actually, this is already beginning to occur; there are now bulletins for this purpose from the ICRP, the

NCRP, the ILO, and the AEC in the Federal Register. I understand that the Army has a code; and the latest statement from the Genetics Commission of the American Academy of Science appeared in The New York Times, in the U. S. News and World Reports magazine, and in Time magazine.

Fortunately, those responsible for formulating the AEC controls on radiation recognized these problems and patterned their standards on the work that had been done over a period of years by the ICRP and, particularly, by the NCRP. For the most part, they have done an excellent job in conforming to the recommendations of these groups to maintain a single standard.

However, the difficulties of preparing such regulations without official liaison with the NCRP resulted, for example, in one problem that disturbed those using cobalt and cesium teletherapy units. This came about, in part, from a difference in interpretation due to the different wording of provisions for the same regulation, a circumstance that could have been prevented had official interchange been in operation.

The AEC published its proposal of standards for protection against radiation in the July 16, 1955, issue of the Federal Register. Within a few weeks considerable confusion developed, and serious objections were voiced concerning the wording of certain sections of this proposal. These standards were crystallized at the Fourth International Teletherapy Conference at Ottawa, Canada, in October 1955 by the participants from the United States.

The AEC definition of radiation areas in effect established a new permissible dose that was not consistent with the recommendations of the NCRP. Second, the recommended limits of radiation level in uncontrolled areas of 2 millirem in any one hour constituted an unnecessary restriction not required in all cases for compliance with the maximum permissible dose of 30 millirem/week for nonoccupational exposure.

These discrepancies and appropriate recommendations were transmitted at the end of the meeting to the Division of Civilian Application of the AEC in Washington. A reply was received from the Radiation Branch, Health and Safety Laboratory, in the New York Operations Office, on May 7, 1956, which explained that their definition of radiation area was not different from the one recommended by the NCRP in NBS Handbook 61, but, rather, it merely affixes a number to the Handbook phrasing.

The second problem was handled by rewriting Secs. 2012 and 2014 of the proposal in a more acceptable manner. The new versions of these sections are, in part, less restrictive than the former ones, and they facilitate, in some instances, the shielding problem in isotope teletherapy without impairing the safety of the installation.

In this particular situation the AEC regulations required compliance with standards practically the same as those recommended by the NCRP, but, instead of being identical, they still vary on certain points. For example, the AEC affixes a number to the NBS Hand-

book 61 definition of radiation area and in another instance sets itself as a judge of occupancy factors. However, I understand now that this last objection has been eliminated in the final version approved by the AEC General Council and will appear in the next issue of the Federal Register.

The more precise definitions of the AEC requirements are perhaps desirable from the safety standpoint; nevertheless, they result in the existence of two sets of standards, very similar but not identical. These difficulties emphasize again the paramount importance of a single set of standards for all sources of radiation applied to all groups and the necessity of official consultation and interchange with the ICRP and the NCRP.

Nevertheless, it is good to know that reasonable and sincere recommendations, presented in a constructive manner to governmental agencies and legislative bodies, are given consideration. At the same time it required considerable work and expense on the part of radiation physicists, radiologists, and manufacturers of teletherapy equipment to obtain these alterations. It behooves us all to be aware of legislative proposals in our states and to study them before enactment in order to maintain uniform standards.

In the medical field any proposals for legislation governing the safe application of ionizing radiations must acknowledge certain problems that are involved in the treatment of patients. A clear distinction should be made between accidental exposure to radiation and the purposeful exposure of patients for diagnostic or therapeutic procedures. The first category results usually in a whole-body exposure and should not be distinguished from industrial hazards. In the second category the health condition of the patient often warrants the delivery of doses considerably higher than permissible standards. The determination of exposure in this group must not be legislated upon, and the necessity of the procedure must be left to the judgment of the physician.

Fortunately, radiation exposure for medical purposes is usually restricted to a small segment of the body, and, when properly applied, the dose to the gonads is low and can be controlled. It is highly desirable to reduce the radiation delivered to the patient during diagnostic and therapeutic procedures, but this should not be a problem for legislation; it should be the responsibility of national medical societies, with the help of the radiological societies and committees created for this purpose and for educating the medical profession in safe radiologic procedures.

In summary, the rapid increase in the use of nuclear energy and accelerators generating ionizing radiation results in the exposure to radiation of alarmingly large segments of the population. It appears that a form of legislation is highly desirable in order to restrict the use of ionizing radiations to qualified personnel and to maintain the radiation hazards below well-established levels.

Second, it is vitally important that such legislation be based on a uniform set of standards developed and

periodically re-evaluated on the basis of the available data from groups of well-recognized scientists, which should continue to be the ICRP at the international level and the NCRP at the national level.

Third, this legislation should apply to all forms of radiation and should be applicable to all groups.

Fourth, national legislation covering the distribution and safe use of certain sources of ionizing radiation is already in effect in the Atomic Energy Act of 1954. State and municipal governments are bound to follow. Two states already have codes. The legislation so far enacted does not pertain to naturally occurring radioactive elements and accelerators.

Fifth, the legislation of the medical applications of ionizing radiation presents special problems in regard to patients, and the dose delivered to them should not be regulated by legislation but should be left to the judgment of the physician.

We shall now proceed with an open discussion of this subject. I shall ask Dr. Brucer to open the discussion because it was he who sparked and set up the Fourth International Teletherapy Conference at Ottawa in October 1955, where the discussions centered about this subject and without which the regulations would not have been changed.

DISCUSSION

CHAPTER 63

Bruce: There is only one point with which I have any major criticism of the legislative attempts now being made. Dr. Scott has already mentioned it. Before World War II, we had one international commission that set a single figure representing the danger point for radiation. We may not have agreed with the international commission in detail, but this was one figure around which we could concentrate our arguments. The situation has now changed. We not only have a multiplicity of maximum permissible doses but we also have a multiplicity of legislative bodies that are putting the force of law behind what all of us know to be pure opinion frequently undiluted by fact.

This is best illustrated by the interpretation that one of our great national news magazines placed on both the British and the United States National Academy of Science statements on the dangers of radiation. It does not matter what was said in the official Government-sponsored reports. It is the interpretation of what the scientists said that is important. I cannot quote the official statement of the magazine exactly, but I can almost quote it: "People will think twice from now on before they will allow their physician to apply therapeutic radiation for any disease whatsoever." Placed immediately adjacent to this statement was a picture of a radiation device. This was not a therapeutic device; it was a picture of a diagnostic X-ray machine. The interpretation of the series of statements on radiation legislation which is being made by the public is not the official grouping of words which represents the considered opinion of a few experts. The real interpretation is that all radiation is exceedingly dangerous and the only way in which the danger can be eliminated is to eliminate all radiation.

The main point here is that we now have multiple committees and multiple standards of radiation. I think it is necessary that we organize in the United States one National Bureau of Standards, or one National Committee on Radiation Protection, or one of any other committee. Even if we got the Woman's Christian Temperance Union to look into the matter,

we would at least come up with one standard that would be recognized as an opinion and not as an administrative edict representing the final word. Such a coordinated declaration of opinion would probably solve most of our problems. It would be physically possible to live with almost any level of radiation if there were only one level that we had to live with.

Braestrup: It may be of interest to all of you to learn just what improvement was made as a result of the meeting in Ottawa. One of the main objections to the proposed Atomic Energy Commission regulation at that time was that it fixed a maximum radiation level irrespective of occupancy; this regulation has been eliminated.

I think also it is of interest that Committee III of the International Commission on Radiation Protection has adopted several of the National Commission on Radiation Protection recommendations of National Bureau of Standards (NBS) Handbook 54; we shall have, in the field of teletherapy, uniform protection recommendations all over the world. Several improvements were made at Geneva in the recommendations for teletherapy. It is proposed to incorporate these in the pending revision of NBS Handbook 54.

Dr. Scott pointed out the number of different regulations in different areas; I think the condition in New York State is typical. We have two different state regulations, the Sanitary Code and the Industrial Code, the first being for medical, and the latter, for industrial installations.

Ter-Pogossian: Apparently there is a considerable amount of criticism of the therapeutic and, particularly, the diagnostic methods using radiation. I believe, to a great degree, this criticism is quite justified. It should be quite easy to reduce, by a tremendously large factor, the dose of radiation delivered to the patient and to the gonads of the patient during these procedures.

First, let us consider very briefly the doses of radiation delivered during standard diagnostic exami-

nations. Incidentally, these doses are not precise; I just want to give an order of magnitude.

A standard chest exposure delivers to the patient approximately 10 millirem units. This is one chest film. It may vary considerably, depending upon the kilovoltage used, the size of the patient, and the filter used.

A standard skull exposure probably delivers somewhere around 50 millirem units to the patient.

Finally, an abdominal examination delivers somewhere around 100 millirem units.

Now let us compare these exposures to a standard fluoroscopic examination. Fluoroscopic examination performed with a fluoroscope operated at 4 ma (which is a very low current) delivers approximately 6000 mr/min to the patient. If we compare this dose of radiation to the other diagnostic procedures, we see that 1 min of a fluoroscopic examination delivers 600 times more radiation than one chest film, or that one could obtain 600 chest films for the same exposure to radiation.

Furthermore, the quality of a fluoroscopic examination is very low. I mean by this that the brilliance of the fluoroscopic screen is so low that most of the observation is made by broad vision, which is notoriously low as far as the detail is concerned. Furthermore, the human eye can accumulate information for a period of approximately 0.1 sec. Therefore, if a fluoroscope is operated at a current of 4 ma, the amount of information accumulated by the eye corresponds to approximately 0.4 ma-sec. If we compare this figure to the amount of current used during the standard diagnostic procedures, we see that, actually, the amount of information falling on the fluoroscopic screen is considerably lower during these examinations.

I am just trying to emphasize that, first of all, the fluoroscope delivers overwhelmingly more radiation to the patient and to the radiologist than all the other examinations; furthermore, this type of examination is rather poor in quality. Consequently, if we try to reduce the dose of radiation delivered by these procedures, the first target should be the fluoroscope. Then, of course, we can try to reduce the radiation from the other examinations.

There are many ways we can do it. An adequate filtration of the X-ray unit reduces considerably the amount of radiation. A good definition of the beam will reduce the amount of radiation delivered to the patient. The gonads often can be protected by external shielding. Finally, better fluoroscopic screens, better intensifying screens, can be developed which will utilize much more efficiently the information available in the X-ray beam.

Friedman: I must confess to certain negligences, when irradiating any portion of a patient's body, in failing to apply one or more layers of lead-rubber sheets to the pelvis; this is a kind of inertia that is common to many, if not most, of us.

If a readily available protective garment existed in the form of an apron with a belt, which manufacturers

would advertise and sell, its presence in every radiation laboratory and the ease of its application to the patient would prompt its frequent use not only in X-ray therapy but also, more importantly, in X-ray diagnosis.

Scott: In this respect I should like to say that the American College of Radiology is trying to gather together a group of the best minds in the United States for a meeting on this subject to evolve a program much along the lines suggested here by Dr. Ter-Pogossian and Dr. Friedman. I think that we should wait until this group has formulated a plan before we go into action.

There is another important group involved in any legislation concerning radiation protection; these are the people who manufacture equipment, who can also provide ways and means of decreasing radiation exposure. They are involved in the planning and the installation of this equipment, in the development of protective barriers, etc. I should like to call on Mr. Stober of the Westinghouse Electric Corporation to give us a short discussion of his views in this field.

Stober: Before presenting my idea of the challenge this gives to the manufacturer, I should like to comment on one or two points that I think are very important to radiologists in general.

It is most important for every radiologist to do what Dr. Scott is attempting to do here. A year or more ago the danger was much greater in that legislation was being evolved without the attention of radiologists. This is normal because radiologists have a job to do, and their normal work is not legislation. It is most important for the societies of radiologists to support this subject and to give it scientific control.

In America the general public is becoming alarmed over a situation that is well known to us, but this is the public's first pseudo education on the subject. Consequently it will become alarmed unduly. I should like to suggest that every radiologist instruct his staff members in the method for discussing this subject with patients. This includes technicians because the things your technicians say to the average patient will have a definite bearing on the subject.

Patients need reassurance. I can remember the day when the first question they asked on coming into the X-ray laboratory was, "Am I going to get an electrical shock?" We had to reassure them constantly. Now, merely a change in this type of thinking is required. If the radiologists become more aware of the problem, both from the standpoint of attempting to guide good legislation and from the standpoint of dealing with the general public, it will help a great deal.

We are not going to stop using radiation; radiation is good medicine. We shall all learn better methods for the application of radiation as we go along. The whole theme is to reach the needed result with the lowest possible amounts of radiation. In the manufacture of equipment we can do a great deal to reduce the amounts of radiation. Image intensification in fluoroscopy is probably the most fertile field. To indicate the level of expense for developments of this

type, my own company has put in excess of a million dollars into the image-intensifier tube. It will take time and a great deal of money to provide good X-ray images with the extremely small amounts of radiation that we should like to be using.

Along with the improvements in equipment will come improved techniques of use; and I particularly like Dr. Friedman's suggestion, one of the first I have heard, of the use of a protective garment for the patient. I think this is a very fertile field; but it also requires that a good deal of psychology be employed. It is comparable to the decision of the airlines, many years ago, that they would not put parachutes in commercial airplanes. They have had occasion to regret it, but without that decision there probably would have been a slow growth of the airline industry.

Loevinger: Regarding X rays in the diagnostic range, it seems clear that, unless the leakage of the tube head is in excess of present standards, the dose to the patient outside the primary field arises from scatter within the patient. The effect of a protective garment would be to hold the radiation in, so to speak, instead of to protect the patient. One might or might not want such a garment for psychological reasons, but that is quite a different matter from radiation protection.

Clark: There was a report in the May 1956 Dental Journal stating that about 10 per cent of the skin dose to the jaw was incident at the gonad region. This indicates that, in dental work, it probably has gone through the air and was not scattered from the body.

Berman: There is one exception to what Dr. Loevinger has said, and that is in irradiating an inguinal field. Merely interposing some shielding material about the field to protect the gonads is not enough; but the scatter from the thigh can be minimized by surrounding the testes with protective material.

Tubiana: In France there is now legislation only for radioactive isotopes and fissionable matter, but there are recommendations for other ionizing radiations.

The legislation problem has been discussed many times during the last few years, but many difficulties have arisen, especially for the determination of the maximum permissible dose. The present state of our knowledge does not permit us to be certain that 0.3

r/week will always be considered an adequate level (0.3 r/week is 15 r/year and 450 r/30 years, which seems to be too much). It is very difficult to make laws using this MPD, and then to change its level every few years. Rather than make laws on such movable ground, it may be better to refer to an MPD chosen by an international body whose decision and regulation will be much less discussed. Aside from this, the need for international legislation is very great for associated problems such as pollution of air and water by fission products and isotopes with long half lives. This is especially important in Europe, where countries are relatively small, thus allowing one country to be polluted by radioactive isotopes coming from another country, and where there are international rivers, such as the Rhine between France and Germany, and some seas, such as the Mediterranean Sea.

I also think there is a great need for international cooperation for determination of the permissible dose and for determination of the quantity of radiation to the gonads which could be tolerated during X-ray procedures. Above all we need research in X-ray techniques to determine how to obtain good films with the smallest possible gonad dose.

This problem is especially important for children because the distance from the field to the gonads is short and the amount of scattered radiation that reaches the gonads is more important than that in adults.

More and more people now take movies during X-ray procedures. This could lengthen the time of fluoroscopy; even with a picture-amplifier technique, the dose to the gonads would still be high.

Scott: Certainly it is urgent that the indiscriminate use of fluoroscopes by pediatricians and general practitioners who are not familiar with the dangers of radiation be corrected.

From all this discussion we can now see that we are dealing with a problem of tremendous political implication and magnitude and that the subject is now beginning to fascinate our social-welfare planners. We radiologists must maintain our leadership in this field by becoming more active, by developing sound recommendations, and by seeing that they are widely disseminated.

What Needs To Be Done in Radiotherapeutic Research

CHAPTER 64

D. W. Smithers

The Royal Marsden Hospital
London, England

Abstract

Further purely technical advances alone are not very likely to produce any marked effect on the results of radiotherapy for cancer. We are now, for the first time, equipped with suitable apparatus and a fine variety of radioactive isotopes, in our larger radiotherapy departments at least. It seems that what we most need is to learn to use to full advantage what we already have. For this purpose we should like to know more about the biophysical action of radiation at the cellular level. We should like to know about the nature of the process of disorganized growth and the effects of radiation on it at both the whole organ and the whole patient levels. We should like to achieve a better understanding among medical consultants deciding in collaboration what form of treatment is likely to be best for each patient, be it surgery, radiotherapy, hormone therapy, or chemotherapy, either alone or in combination. Along these three paths of fundamental radiobiology, radiopathology studied in the cancer patient, and effective collaboration among medical consultants, considerable progress might be made. Some possible directions for such progress are indicated.

I am another of the Brucer victims. I would never have chosen a subject as difficult as this. To talk of radiotherapy in relation to its research requirements just when it is going through all the psychological upheavals and structural changes of puberty is not easy. It is perhaps well for us to remember from the start that radiotherapy is still a very young branch of therapeutics.

I suspect that the idea of having me give this general talk in the middle of a seminar on supervoltage and gamma-beam therapy was that I should speak about the radiotherapist's requirements for more powerful or better apparatus and their future application with greater technical efficiency.

Four years ago, when I was here last, we were having a discussion on questions of this sort; we lightheartedly talked of our fancy for a mobile ceiling-suspended telecurie apparatus producing a well-defined high-output beam of penetrating radiation. This radiation would be directed in such a way that

both apparatus and patient would waltz together in a manner determined by an electronic dose computer that had been set to raise a predetermined tissue volume to a specified dose with maximum economy in normal tissue irradiation. Since you have come here, you have seen the cesium machine and how this farfetched fancy has almost, if fantastically, been achieved.

We also thought then that it might be pleasant to watch, in the control room, the movement of the exit path of the beam as seen by a television camera, observing a fluorescent screen on the far side of the patient in the treatment room, arranged to provide a continuous check on the accuracy of the beam direction.

Parts of what seemed a rather foolish fantasy already have become fact, and we could now be supplied with all this if we could persuade ourselves that it is of sufficient importance. Electronic computers are doing more difficult jobs; the Lumacon has made distant fluorescent screen viewing practicable; and sufficiently flexible supervoltage apparatus and telecurie units are readily available. Perhaps the next step may be the introduction of a high-voltage scanned X-ray treatment tube providing moving convergent beams or any other shapes that ingenuity can devise. Perhaps we may develop an apparatus of constantly variable megavoltage which automatically displaces the maximum to the depth of the tumor from whatever angle or through whatever thickness of tissue it first passes.

The important point I should like to consider at present is whether it would matter very much if all these wild dreams did come true. It does not seem to me that further purely technical advances of this kind, useful though they may be, are now likely to make any very great difference in the results of radiotherapy for cancer.

Radiotherapy is growing up, and for the very first time it has at its disposal, for routine work in all parts of the body, beams of good quality and a wonder-

ful variety of radioactive materials. The need for the future is to learn to use what we already have to its full advantage. We are never likely to get a much better chance to show what we can do in terms of available radiation sources.

The future development of radiotherapy for cancer lies, I believe, in three directions of better understanding:

1. The biophysical action of radiation at the cellular level.
2. The nature of the process of disorganized growth and the effects of radiation on it at the organ, or even at the whole patient, level.
3. The best use for each patient of surgery, radiotherapy, hormone therapy, and chemotherapy, alone or in combination, at the medical-consultant level.

I shall skip over the biophysics rather rapidly by showing only two figures and by trying to make three points.

Let me make the three points first. The most significant recognized differences between ionizing radiations being absorbed in a continuous medium would seem to be the ion density produced along the particle tracks, or the linear energy transfer (LET). The elucidation of the problems that are concerned with the relative efficiency, for different purposes, of radiation producing different LET's under controllable alterations in oxygen tension or chemical environment might well be turned to practical therapeutic use. There is possibly some evidence already that the region of 200 to 300 ions per micron of particle track may have some special biological interest and that a proton beam may, on this account as on several others, be worth an extensive therapeutic trial. Perhaps radiotherapists should now begin to talk not only in terms of rads when discussing dose but also of yield of available radioactive elements when discussing differences in biological effect between the radiations they employ.

Figure 1 indicates the area of interest. The act of irradiation, the transfer of energy from subatomic particles to molecules along their paths, can be studied; the observed biological effects, deviations from the normal in structure or function, can also be studied; but we do not seem able to examine a latent period between these two. We know something about the tracks of particles and the distribution of the ionized and excited molecules. We can have direct information on this subject. We can also have direct information of effects produced, e.g., by mutations, chromosome breaks, and changes in permeability, but the important activities between ionization and observed effect are still largely obscure. It is here that I think we need a great deal more interest and information for the future from biophysics.

Figure 2 shows (1) the types of beam we are used to, which fall off regularly with depth, (2) the electron beam at 16 Mev, which a few people are becoming used to and which may have some advantages, and (3) the interesting deuteron beam, which, as far as I know, has not been used as yet for a real clinical time.

Having skipped over basic biophysics in a few moments, I shall say a little more about the other two directions in which to look for better understanding, which are to me a little nearer home.

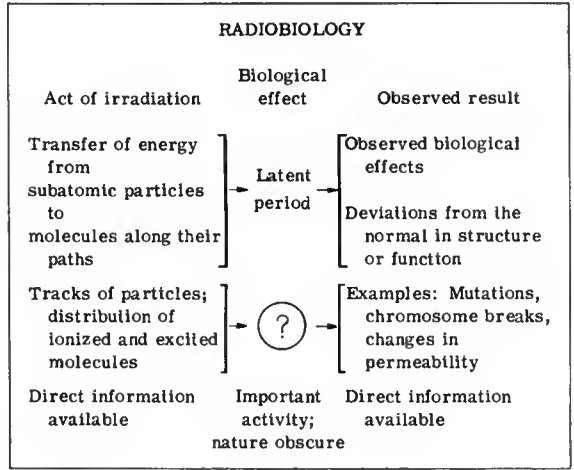

Fig. 1.

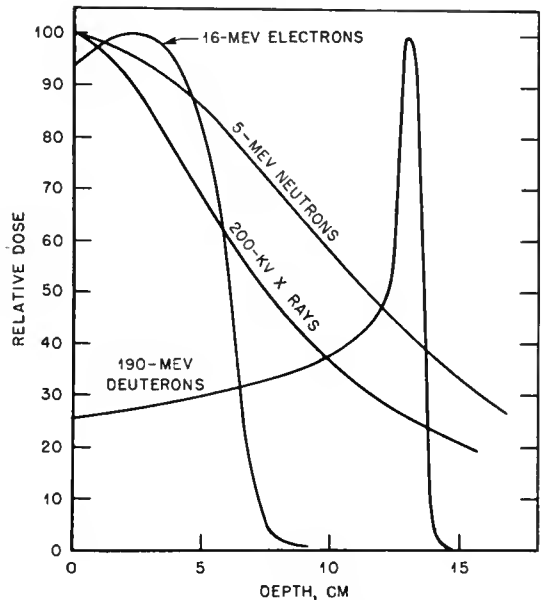

Fig. 2—Typical depth-dose curves in tissue of unit density for various ionizing radiations. [Taken from The Relative Biological Effect of Different Ionizing Radiations (Fig. 1), by J. W. Boag, National Bureau of Standards Report, 1953.]

Let us talk for a moment about radiopathology. Rather surprisingly, far less work seems to have been done on the effects of radiation at the level of organized cell groups or whole organs than at the molecular level, although there is much more work again at the level of whole patients. This emphasis reflects the modern interest in radiobiology, which has very little to do with radiotherapy at all. The increase in the attention paid to radiation hazards has

produced great interest in whole-body effects and has led to work that may one day, as a side effect, prove useful in radiotherapy.

Considering that cancer is a common disease and that over 70 per cent of the patients who receive treatment for it have some form of radiotherapy, the comparative lack of interest of morbid histologists and clinical pathologists in the effects of therapeutic doses of radiation in man seems extremely odd.

The clinical physicist has spent much time and has done fine work on the macroscopic pattern of energy absorption, even if, as we heard earlier, he seems to be tiring of his labors in this field. These smoothed-out distributions of average energy absorbed per gram in wax men, with all the paraphernalia of isodose curves and isodose surfaces, must now be refined, as was said earlier, in terms of absolute energy absorption according to differences in tissue composition; and, as also was previously expressed, it is important that we keep in step with the increasing complexities of our therapeutic techniques.

Fortunately for us, supervoltage radiation has come to our aid just when we were finding that we needed it most to simplify our calculations of dose distribution. There is still a need for further technical development here. We have tried to fill this need in two ways:

1. By the construction of a precision stereoscopic viewer for radiographs, on which each beam of radiation can be plotted in relation to the composition of the tissues through which it passes.
2. By the use of multiple continuous-reading dose-rate meters (placed on the surface or within body cavities during treatment) which actuate pen recorders in the control rooms.

Although an accurate knowledge of physical dose distribution in the tissues irradiated is the first most necessary step toward the assessment of biological effects, it is nevertheless those biological effects that really interest us. It is this biological interest that has now been reflected in the research activities of many hospital physics departments in Great Britain. There is now some danger that we may suffer deterioration in the background physical accuracy of our radiotherapy in exchange for what may be basically more interesting experimental work for the clinical physicist. This biological work is perhaps too often done by people who are not themselves well grounded either in biology or in clinical medicine. The physicists' growing value in fundamental biophysics is undoubted and most welcome; their extension to radiopathology is far less helpful when they tend to exclude pathologists (better qualified in this work than themselves) from this sadly neglected field.

In my opinion there is a real need for independent radiobiological departments, staffed primarily by biologists, of the same quality as our best hospital physics departments, in which the staff practices the old day-to-day collaboration between scientist and doctor concerning individual patients, which has been such a feature of British radiotherapy.

It was this development of clinical physics in Great Britain which helped more than anything else to raise the quality of our radiotherapy. The next step in radiotherapy progress will greatly depend on how we now manage both to maintain our clinical physics and to develop comparable departments of clinical radiobiology by budding off, rather than have independent departments of biophysics in place of both.

Here in America the tendency has been to bring a number of doctors into radiotherapy who were first interested in radiobiology and thus to center these new research developments under the radiotherapists themselves. This has many advantages, but it also has some dangers. A radiotherapist must be first and foremost a clinician. A director who finds his radiotherapy department interesting chiefly as a place where he can conduct experiments in radiobiology is not likely to do the best that can be done for his patients. The clinical physics departments that flowered best were independent of direct radiotherapy control and had both the initiative and the right to develop on their own lines. This arrangement seems to work well as long as these independent departments retain a close daily liaison with the clinical units they were first designed to serve. When they grow away from the idea of the direct clinical service to which radiotherapy is devoted, as some may rightly and usefully do, there seems every reason why they should at once be replaced by departments primarily concerned with clinical investigation. If not, radiotherapy practice may suffer now for the sake of some future which, when it comes, will still need practical application.

These questions of how we now manage the further development of research in clinical radiobiology and clinical physics are fundamental to the proper future development of radiotherapy. The new clinical-radiobiological departments seem to me to need pathologists most of all. Much of the emphasis in the radiopathology that does exist has been placed on the direct effect of irradiation on the dividing cancer cell. Although this is of great interest, it can be only part of the story. No one now suggests that the elimination of a malignant tumor by irradiation depends upon the direct destruction of every tumor cell. No doubt some premitotic cells are more sensitive than others, but much of the effect of a radiation treatment will depend on the proportion and distribution of these cells and on the nature of the stroma and the tumor bed which support them.

The cellularity and lack of support of a lymphosarcoma produce a very different response from that of a fibrosarcoma, which is all support and often little cell division. A Wilms's tumor may be highly active and unsupported in parts but rigid and slowly reproducing in others, showing by massive breakdown of whole sections of the tumor an apparent radiosensitivity belied by its subsequent behavior. A well-differentiated squamous-cell carcinoma, for all its pearl formation, may show compact clumps of dividing cells scattered throughout its mass in such

a way that the whole tumor quickly becomes disorganized when energetically irradiated. Figure 3 shows the structure of a typical lymphosarcoma; it begins to disrupt immediately on irradiation.

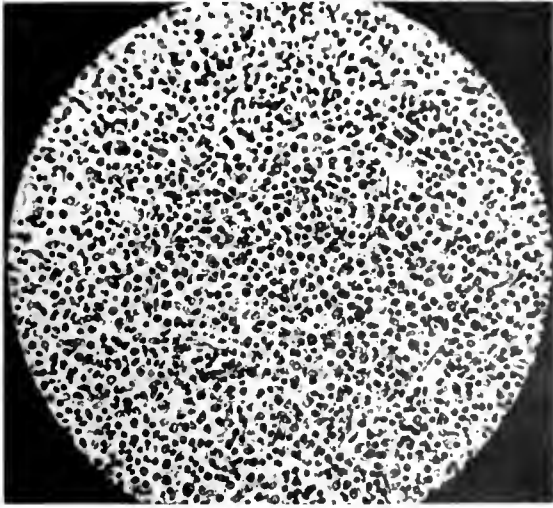

Fig. 3—Structure of a typical lymphosarcoma.

radiosensitivity may well be principally due to gross tumor structure. When we think in terms of carefully planned homogeneous tumor dose distributions, we should remember that they are still being applied indiscriminately to tumors varying grossly in composition.

The reaction of the normal tissues to injury is of the utmost importance to the radiotherapist. The tissue reactions already present around an invading

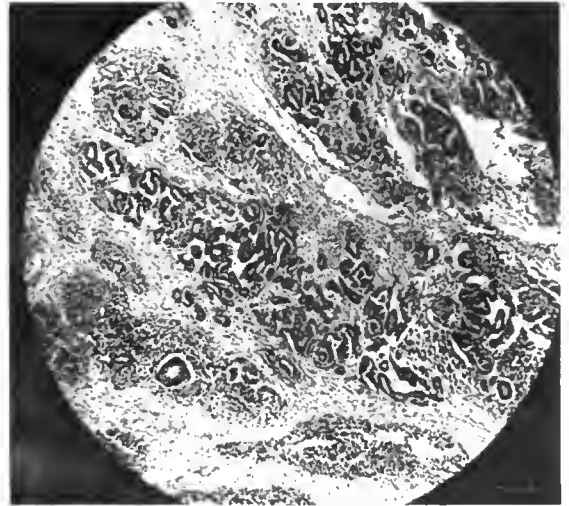

Fig. 5—A portion of a Wilms's tumor.

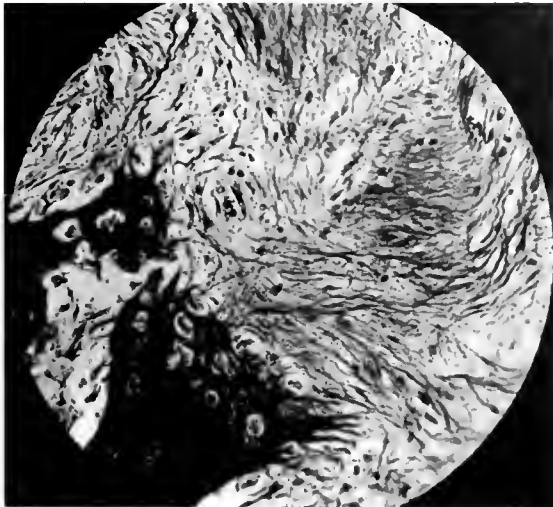

Fig. 4—A portion of a fibrosarcoma.

Figure 4 shows a portion of a fibrosarcoma, which, when irradiated, does not easily disrupt even if all the dividing cells are at once knocked out.

Figure 5 shows a bit of a Wilms's tumor, which can easily show a wide variety of response from one part of the tumor to another.

Figure 6 shows a squamous-cell carcinoma with pearl formation, in which the dividing cells can be found branched together around the growing edges of cell clumps. When this is irradiated, it may soon become disorganized, although it is a fairly well differentiated tumor.

These gross differences in response may all be initiated by a similar primary effect of the radiation on dividing tumor cells because many differences in

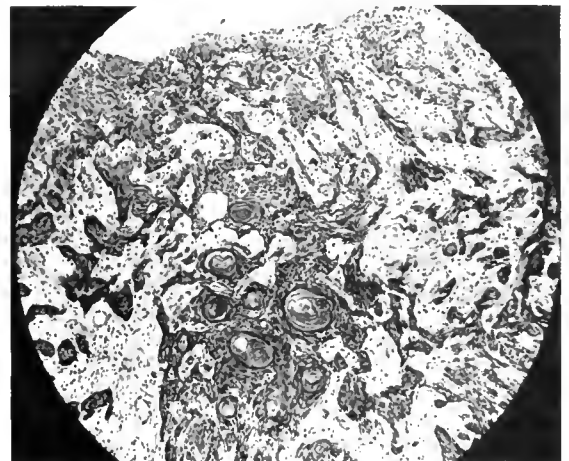

Fig. 6—Squamous-cell carcinoma with pearl formation.

tumor and the new reactions induced by treatment form a most important part of the whole story of radiation effect. Connective tissue is no longer regarded as an inert supporting structure: it is highly active metabolically; it responds to changes in hormone balance. The collagen formation and cellular reaction in the stroma is a vital part of tumor response, which merits far more attention in radiotherapy than it is getting at present.

The modification of radiation effects by the simultaneous use of chemicals with a known action on

tissue response to injury would seem to have considerable possibility. The synergistic effect of the other chemical compounds, which augment cell breakdown when combined with irradiation, may also have a field of usefulness, especially if we can move from general, unselective mitotic poisons to specific tissue depressants.

Work at this level of tumor, organ, and tissue organization, which is concerned with the radiation effects initiated by dividing-cell degeneration, continued by host reaction, and modified by the further effect of radiation on that reaction, is one of our outstanding research needs for the future.

These investigations must be carried further to the level of the whole man. Many people, whose approach has been from the direction of civil defense and health hazards, are working already in this field. They have already contributed much of interest to the radiotherapist. We should try to find how this work can apply to our day-to-day practice.

Figure 7 is worth a glance because we still tend to think in terms of undue simplicity about the clinical effects of radiation. We concentrate on the radiation absorbed in the tumor, and we should try to remember that we are dealing with a complicated affair.

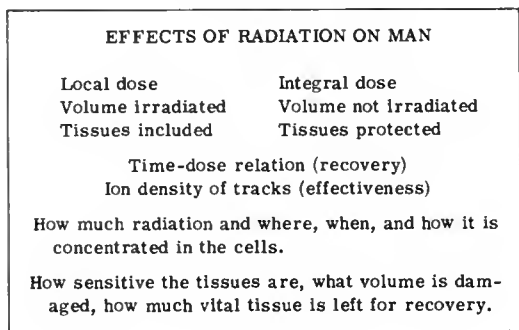

Fig. 7.

We must think not only in terms of local dose and of integral dose, which we are fairly used to, but also in terms of the volume irradiated and the volume not irradiated; the tissues included and the tissues protected; the time-dose relation, which is so important for recovery; and the ion density of the tracks, which is so important for effectiveness. I have tried to sum it up by saying that the important thing is how much radiation there is; where, when, and how it is concentrated in the cells; how sensitive the tissues are; what volume is damaged; and how much vital tissue is left for recovery.

There is some interesting work, for example, on the variation of local tumor effect with given dose when small doses of total-body irradiation are added. There has been far more work done on the biochemistry and the changes in electrolyte balance in man following surgery than after irradiation. These effects and their modification by chemicals that compete for the active elements formed by the ionization might perhaps be used to increase relative tumor effect.

In this field of radiopathology (both in the histological and biochemical studies), radioactive-tracer work holds out great possibilities for acquiring useful new information. We urgently need more pathologists who will take as their field of study the effects of radiation on man, at therapeutic dose levels.

I have spoken of the possible advances reaching clinical radiotherapy from biophysical work at the level of the cell and from radiopathological work at the level of the tissue, the organ, or the whole man. The last direction from which advances may come is the level of collaboration among medical consultants in different specialties. This is a branch of clinical research which I think comes justifiably under the heading now being discussed. I think it is of very great importance.

No longer can we do the best possible for our patients by competing for the chance to find out what we can achieve alone with that one small part of the art of therapeutics in which we happen to specialize or by employing all specialties ourselves. There are a few shining exceptions, but we have seen the sad disrepute into which radiotherapy has fallen at times when practiced by surgeons, and surgery would certainly not be advanced by our active invasion of their highly skilled branch of cancer treatment. To this situation have more recently been added the attentions of others, with chemotherapy, hormone therapy, and even that part of radiotherapy that can now be given by mouth or by injection and so is fair game for the inexperienced person who wants to try his hand.

It was not easy in the past for the inexperienced to wade in and take over the complications of advanced surgical and radiation techniques. Anyone now can, and some now do, without any consultation with others, give patients drugs that destroy their bone marrow and so make effective treatment by other means impossible; or they try experimental injections and untried or even discredited remedies throughout the one period during which effective treatment might still have been given.

The public has long been fed improper tales of the inevitable incurability of cancer; and the large portion of the medical profession that sees only a few cancer patients each year is not well qualified to judge what might now be done for each one of them by all available modern methods. We need to establish a proper system of joint consultation about the treatment of cancer patients among surgeons, physicians, and radiotherapists, united in an attempt to do the best that can be done for each patient, by using any or all of the treatment methods available.

We must ask that doctors send their patients suspected of cancer to such centers as soon as their suspicions are aroused and before, not after, some one treatment available to them has proved ineffective. We have been running such a scheme for the past 12 years among a group of special hospitals in London, with most interesting results. The five-year survival rate in one of these hospitals has been doubled since surgeons and radiotherapists com-

bined to take a personal interest in the outcome of the treatment they had together agreed upon for every cancer patient, since both saw regularly the patients treated by the other.

Let us finish by taking a few examples. Advanced cancer of the breast is made worse by unsuccessful surgical intervention but can sometimes be controlled for many years by irradiation. Figure 8 shows a woman who, 13 years before this picture was taken, had a mass in the breast fixed to the skin and muscle and a large matted mass of axillary nodes also. In some centers, even today, she would have had a radical mastectomy, with little hope of success, and would have lost her main chance of survival. In those clinics where surgeons work with radiotherapists and have seen what can be done for patients like this, the patient has a better chance. The old days are mercifully gone when massive recurrences in plaques all over the chest wall following mastectomy on locally advanced cases were so distressingly common.

The persistence with radiotherapy at sites where it has done no good and where surgery has some success, such as the jaw or the lower end of the esophagus, is another example of what I mean, but in the reverse direction. The use of external low-voltage irradiation at 200 kv for advanced cancer of the mouth and throat is ineffective but is still unfortunately a common practice. It is still being referred to as "conventional."

Some conditions are curable only by the proper combination of surgery and irradiation; the best example of this is the extensive basal-cell carcinoma involving bone. Fortunately there are not very many of these today. Figure 9 shows a rather feeble-minded woman who neglected her basal-cell carcinoma until she arrived in this state. Some people would think that she was not curable by any means, and I assure you she is only curable by a combination of surgery and irradiation. Surgery alone for these patients merely pushes the disease further and further back so that it requires more and more excision until nothing of the patient's face remains. Irradiation produces the effect seen in Fig. 10, excellent in the soft tissue but still leaving extensive disease hidden deep in the bone below. The next stage after irradiation, which has reduced the activity and limited the extent of the tumor so that you can see what you have to deal with, is to remove the bone involvement (Fig. 11); and the next stage is to effect some plastic repair (Fig. 12). This woman has now had a false palate made and is able to wear an excellent prosthesis. With a good pair of spectacles and a glass eye, she does not look too bad at all. My surgical colleague W. A. Mill and I did all this nine years ago.

There is a real need for well-prepared clinical trials to test the usefulness of different methods or combinations of methods in those cases in which, despite long experience, serious doubt about the efficacy of treatment still remains.

The use of radiotherapy and nitrogen mustards together or alone in Hodgkin's disease or the use of myleran and radiotherapy in myeloid leukemia are

further examples of the need for cooperation between radiotherapists and physicians if the patient is to secure the best possible treatment for his need. I could continue to give examples like this at length, but I hope the point is already made.

Although I believe that much progress in dealing with local malignant disease is still possible by



Fig. 8—Patient who had a locally advanced stage 3 carcinoma of the breast at the age of 53. She was treated by radiotherapy only, in 1943, and 13 years later there was no sign of recurrence.

means of intelligent and useful cooperation among specialists, a great treatment problem still remains: this is how to deal with cancer that has already become disseminated. Two exciting things have come to the fore in the last 15 years or so which bring new hope into this field. One is the introduction of radioactive isotopes, and the other is the alteration in hormone balance as a means of controlling dependent tumors.

After the initial excitement over the introduction of radioactive isotopes, there seems to have been a reaction to the effect that these radioactive isotopes had contributed nothing of real value. The time has come for a reasonable assessment of their present worth and for a sensible view of their possible future. In thyroid cancer alone, great things have happened. Some patients (even if it is a small proportion of the whole) with widely disseminated disease have, for the first time in the history of such disease, been cured. This is a great advance, and it should be hailed as such. Figures 13 to 15 show a woman whom we saw first in 1954; she had multiple soft tissue and bony metastases from a carcinoma of the thyroid. Figure 13 is the lateral picture of her skull, showing metastasis on her forehead and another large one in the region of the pituitary fossa, together with the



Fig. 9—Woman with massive basal-cell carcinoma of the face before treatment (1946).



Fig. 10—Same patient shown in Fig. 9 after radiotherapy in 1949; regression of tumor involving soft tissues has occurred, but there is persistent growth in bone.



Fig. 11—Same patient shown in Fig. 9 after surgical removal of bone involved by tumor.



Fig. 12—Same patient shown in Fig. 9 after plastic reconstruction of palate and before application of prosthesis (1953).



Fig. 13—(a) Lateral X-ray picture of the skull of a woman with carcinoma of the thyroid (age 64 in 1954), showing bone involvement from a large frontal metastasis and a second metastasis at the base of skull. (b) Automatic scan showing uptake of radioactive iodine in both tumors.



Fig. 14—Same patient shown in Fig. 13 with carcinoma of the thyroid, showing one of the metastases involving bone (1954).



Fig. 15—Same patient shown in Fig. 14 in 1955, showing regression of metastasis after treatment with I^{131} .



Fig. 16—Woman before treatment (age 21 in 1949), ill, wasted, with tracheotomy and multiple metastases in neck and lungs.



Fig. 17—Same patient shown in Fig. 16 in 1950 after treatment with I^{131} , showing tracheotomy closed and developing myxedema.



Fig. 18—Same patient shown in Fig. 16 at conclusion of treatment in 1951, before going on thyroid extract; full myxedema has developed.



Fig. 19—Same patient shown in Fig. 16 back to normal activity on thyroid extract; there is no sign of recurrence (1955).



Fig. 20—Woman, aged 24 in 1949, with anaplastic carcinoma of the stomach and multiple metastases, showing regression of two of these after treatment with P^{32} .



Fig. 21—Woman (age 44) with multiple metastases in lungs from carcinoma of the breast, before treatment.



Fig. 22—Normal X ray of lungs following oophorectomy and adrenalectomy of same patient shown in Fig. 21.

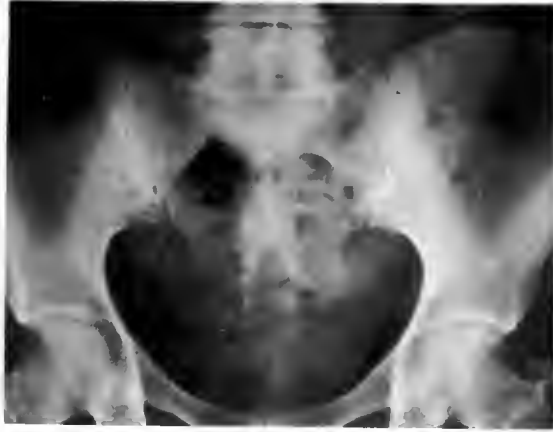

Fig. 23—Same patient shown in Fig. 21, showing multiple metastases in bone before treatment.

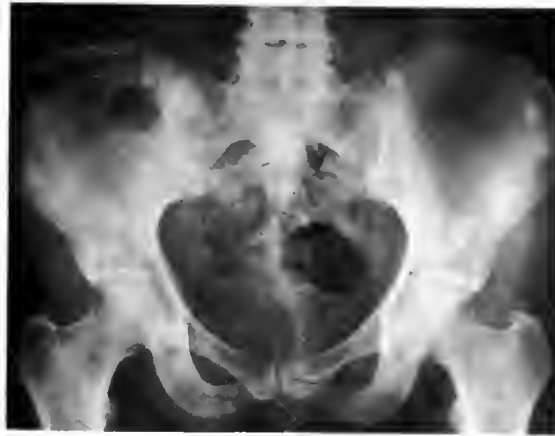

Fig. 24—Multiple areas of sclerosis in bone following oophorectomy and adrenalectomy of same patient shown in Fig. 21.



Fig. 25—Same patient shown in Fig. 21, showing normal X-ray appearances of pelvis after treatment. She is alive and well two years after treatment.

automatic scan. This is a most elegant way of showing the uptake of radioactive iodine in those two tumors, for which I am most grateful to our Physics Department. She had a number of other metastases, which showed equally well. Figure 14 shows the metastasis on her forehead before treatment, and Fig. 15 shows her today. The change in the size of the mass on her head is evident, and a similar change has occurred in her metastases elsewhere. I do not think there is much wrong with the development of radiotherapy when it can begin to demonstrate metastases so beautifully and also to treat them so effectively in this way.

The next patient is, to me, quite fascinating. She was a young woman who came to us with hard nodes in her neck, a fixed thyroid mass, and multiple metastases throughout both lungs. It can be seen that she looked ill and that she had a tracheotomy (Fig. 16). She lapped up iodine, and the next three figures show this girl changing from a very ill young woman right through to marked improvement at the end of treatment (Fig. 17), on to full myxedema (Fig. 18), and then, after thyroid medication, back to her normal charming self (Fig. 19). Now, seven years after her treatment, consisting of a few drinks of radioiodine, she is married and has a child.

The future seems to offer some prospect of finding methods of screening patients with thyroid tumors to find those in which uptake can be induced and then of increasing that uptake to a useful therapeutic level.

Regression of multiple metastases from anaplastic carcinoma has already been accomplished with P^{32} in a few patients. These are unfortunately very few, and it is possible, but perhaps less likely, that this may be extended. I should like to present one case as a matter of interest. The patient, a young woman, had anaplastic carcinoma of the stomach, with multiple metastases scattered throughout her body. Figure 20 shows two of them. She had them scattered through almost every organ in the body, including the brain, liver, gut, and one in the thyroid. With small doses of radioactive phosphorus, they all regressed; she died of multiple areas of necrosis. At post-mortem examination, no residual tumor could be found in any one of those areas. The pathologist thought that she died chiefly from necrosis of a metastasis in the brain.

That this can happen once is, to me, exciting. We should try to discover why it happened and why we

have not been able to accomplish similar regression again.

The labeling of certain amino acids or other organic compounds is another example of a development that may have therapeutic value. Immune reactions have to be explored. It is far too early to give up and say that this method has no future. Radioactive isotopes for treatment are still in the very earliest days of development.

The other exciting attack on multiple metastases has been through alteration in hormone balance. Radiotherapy has a part to play in this, although it may turn out to be a minor one. Irradiation of the ovaries has been shown to be of value, and implantation of unscreened radioactive gold or of Y^{90} pellets through the nose into the pituitary can at times produce dramatic effects. This is a very pretty technique, in which an image amplifier swings through 90 deg on an angle arm, the implant being made up each nostril by direct vision. Much remains to be done in this field for the future.

Let me give just one example of a patient who responded to hormone alteration. The wife of a naval commander, with carcinoma of the breast, had multiple metastases throughout both lungs and in almost every bone in the body. Her lungs before treatment are seen in Fig. 21; after treatment, in Fig. 22. I think the most interesting part is her pelvis, although it may be difficult to see in my illustrations; in Fig. 23 it is rather difficult to see the dark multiple areas of rarefaction in the ilium. However, Fig. 24 shows them much more clearly as multiple areas of sclerosis appearing throughout the pelvis after treatment. Most interesting of all, these sclerotic deposits disappeared, her X-ray appearance returning to that of a normal pelvis (Fig. 25). Oophorectomy and adrenalectomy were performed by my colleague Peter Freening two years ago.

It seems to me that radiotherapy, in its short life, already offers more to cancer patients than any other single form of treatment. Its future is bright because, despite this, it has only recently acquired for the very first time adequate means of application at more than a few special sites. I believe that its progress depends more on further knowledge of its effects at the cellular level, on greater attention to radio-pathology, and on better collaboration with specialists in other fields than on any new technical development we may acquire.

DISCUSSION

CHAPTER 65

Ellis: There are four things that I think are important in connection with research. One of the most important in connection with radiotherapy is oxygen and the effect of oxygen supply on radiosensitivity. Work has been done at St. Thomas's Hospital, London, by Churchill-Davidson et al.¹ on the irradiation of patients under a pressure of 3 atm of oxygen, requiring general anesthesia and also bilateral myringotomy to avoid damage to the ear. The initial results certainly were encouraging. Gray et al.² have published work that shows a very sound fundamental basis for expecting good effects, and I suspect that this might be the greatest single advance in radiotherapy which we shall have seen.

I think another thing we need to know is the extent to which microscopic invasion occurs around a tumor. It is a subject on which I, for one, am woefully ignorant, and I feel that pathological research on this might be possible and useful and should be carried out.

In connection with the question of treating the pituitary to destroy the pituitary, which Professor Smithers mentioned, a paper has been published recently in the British Medical Journal by Hadfield³ on a test for selecting the cases suitable for such treatment. I think the article could be recommended, to anyone who is interested, as indicating the way in which cases likely to respond to such treatment can be found. (See also reference 4.)

Hadfield makes this test by injecting a specimen of the urine of the patient into a series of young male mice and then examining the development of the breasts in these mice five days later. He provides an index, which is a ratio of the total number of little buds of cells in all the breasts to the number of buds in a series of uninjected mice; those buds, histologically, look almost like anaplastic carcinoma at that stage (five days).

One other thing, which is not settled and which might possibly prove important in connection with radiotherapy, is the question of time-intensity re-

lations. I have always been impressed by the difference between X-ray treatment and radium treatment. I do not know whether other people agree with me, but I like to use a radium implant where it is possible. I feel that I get a better result. I do not know whether it is because of the time-intensity relation or just because the radiation is localized to a more restricted volume; but there is certainly a very big difference in the time-intensity relation between fractional radiation and radium treatment given at a very low dosage over a long, continued period.

Meschan: We need a better index or end point for evaluation of the treatment of the patient. The survival values of various types are not helpful early in the irradiation course. Cytologic or histologic studies have not been helpful to us.

Perhaps the biochemist will contrive a study of tissues being irradiated to determine the efficiency of the technique in use.

Smithers: This is interesting, both in relation to the planning of clinical experiments, which I think is an important part of radiotherapy research, and in the way we assess the result we have achieved. I think the statistician is very useful to us, but I still think that one of the best ways of assessing the result is to have a satisfied patient and a satisfied doctor.

Rubenfeld: I think we should return to more clinical research. Years ago we were led by the French School, whose approach to the problem was dominantly clinical. The master at that time, Coutard, taught daily observation of the patient; alertness to the reactions of the skin and mucosa; and observation of tumor response and the effect on the tumor bed. A careful appraisal of all these changes led to the determination of the lethal tumor dose. There followed the era, introduced principally by our British brethren, when the dose in calculated tissue "roentgens" became the dominant feature. Actually, it became easier as a teaching method because residents were taught

that the magic 6000 r must be reached for treatment to be successful.

With supervoltage we are embarking on a pattern of clinical research which closely correlates dose, time, reactions, and tumor response. If dose levels are to be raised to 8000 or 10,000 r, then we are returning to that type of research in which the clinical radiologist, in combination with the physicist, could determine more effectively the biological reactions in relation to the numerical dose.

Smithers: This correlation between dose and observed effect is, of course, extremely important; but we must remember that in the past we have not been able to do this very well because the doses at depth levels have

been most uncertain, and with low-voltage irradiation, with bone in the way, they still are.

References

1. I. Churchill-Davidson, C. Sanger, and R. H. Thomlinson, High-pressure Oxygen and Radiotherapy, *Lancet*, 1: 1091-1095 (1955).
2. L. H. Gray, A. D. Conger, M. Ebert, S. Hornsey, and O. C. A. Scott, The Concentration of Oxygen Dissolved in Tissues at the Time of Irradiation as a Factor in Radiotherapy, *Brit. J. Radiol.*, 26: 638-648 (1953).
3. G. Hadfield, Recent Research in Physiology of Breast Applied to Mammary Cancer, *Brit. Med. J.*, 1: 1507-1511 (1956).
4. G. Hadfield and J. S. Young, The Mammothropic Potency of Human Urine, *Brit. J. Cancer*, 10: 145-168 (1956).

Section
N

Brachytherapy Devices

Marshall Brucer
(presiding)



A Survey of Brachytherapy

CHAPTER 66

Marshall Brucer

Medical Division
Oak Ridge Institute of Nuclear Studies
Oak Ridge, Tennessee

When we first set up the program for this seminar, the committee refused to accept the idea of including brachytherapy devices in a supervoltage meeting. When I defined "supervoltage" for the two physicists and the two therapists on the committee, they became more amenable to the idea. These brachytherapy devices come under the heading of supervoltage radiation; many things can be done with brachytherapy. In fact, almost anything that can be thought of in brachytherapy can now be done.

The whole point is, "What should be done with brachytherapy, and, particularly, what should be done first?" Any therapist can sit down in an easy chair and think up a gadget. This gadget can now be made at almost any reasonable energy level and with almost any reasonable half life. There is a good probability that it can also almost be made into a practical device. The whole question is, "Which of these devices will be more useful in brachytherapy?"

We do not have time to show pictures of everything that is being done. Figure 1 shows a brachytherapy device exhibited by the U. S. S. R. in Geneva, Switzerland, at the Atoms for Peace Conference. The Russians made up a number of sets of more than 170 needles and tubes of Co^{60} encased in a steel sheath. They then made a very beautifully machined radiation safe for these needles. Each needle is put in a separate drawer. There is a possibility that some of you may have seen an idea such as this in a Swedish document, but that is beside the point. We should commend the Russians for one of the most beautiful pieces of machining shown in Geneva. The Russians have also made various kinds of gadgets for loading cobalt needles into various kinds of applicators. They have also made devices for sterilizing the applicator after it has been loaded. Nothing in the way of inspiring new ideas is shown, but, on the other hand, almost every brachytherapy device mentioned in the past few years was also mentioned in the literature on radium before 1910.

Figure 2 shows (as one example) a few of the "revolvers" for the emplacement of small bits of radio-

active material. Three of the atom ray guns are shown in the figure. One is a German device, another is the English copy of the German device, and the third is the American copy of the English copy of the German device. I should not say "copy" in this sense because they are all original devices. I would, however, like to point out that everybody should know that the fundamental patent for the revolver was given to Mr. Colt by the American Congress in 1854.

An example of the German work is shown in the Co^{60} pearls of Becker and Scheer of Heidelberg. The Heidelberg workers have done a tremendous amount of work in the techniques of applying supervoltage radiation in small areas. The balloon filled with a liquid is one of many similar gadgets devised for irregular cavities.

Figure 3 shows the use of cobalt or gold seeds in nylon thread. The people at Ohio State University have been able to achieve a distribution with a very uniform pattern of almost point sources of radiation.

Figure 4 shows the use of ceramic pellets that include some Y^{90} . With these pellets a very intense or a very mild, whichever is wanted, source of beta emission can be placed in very confined areas of the body. Here the Y^{90} pellets were placed by a neuro-surgical technique to give a controlled destruction of the hypophysis.

Figure 5 shows a device made by Paul Harper at the University of Chicago. He has taken a polyethylene tube and has sewed it into the tumor, after which the tube is filled with mercury and an X ray is taken. With multiple radiographs taken in multiple planes, it is possible to reproduce almost exactly the pattern of hemstitching in the tumor, and from this a dosage with almost any liquid isotope can be computed with a high degree of precision. In this kind of device the surgeon has fairly good control of dosage and of positioning. Many extensions of this idea are being followed by a number of institutions.

Figure 6 shows the work of a surgical resident from the Ochsner Clinic in New Orleans, La., who



Fig. 1—Brachytherapy devices exhibited by the U. S. S. R. at the Geneva Conference in 1955.

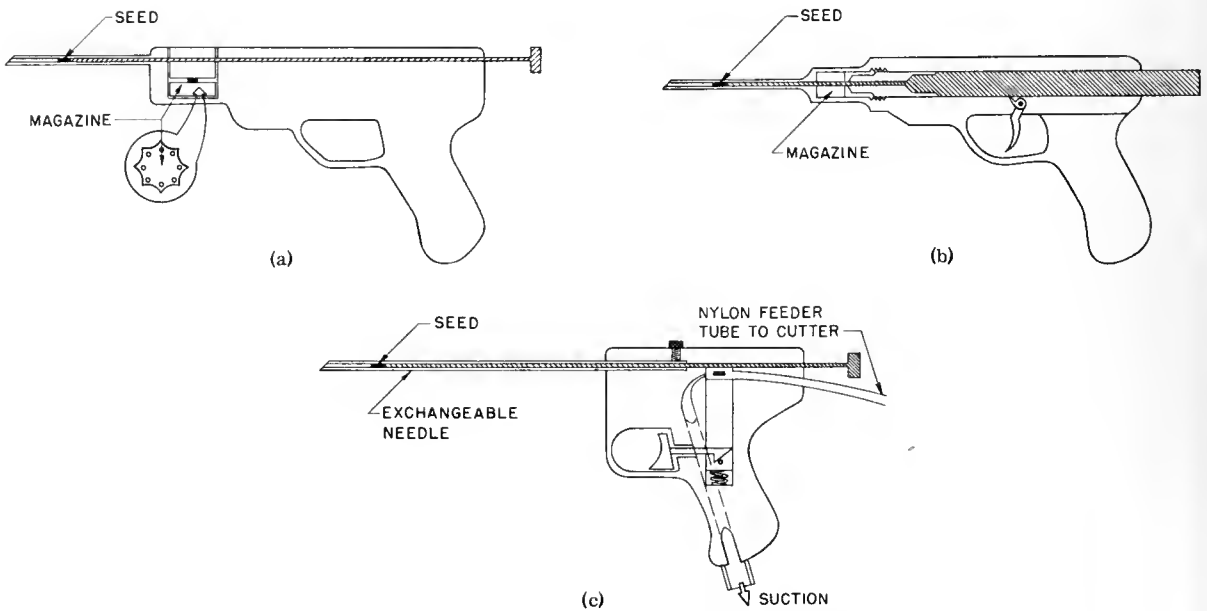

Fig. 2—Revolvers used for emplacement of small particles of radioactive material. (a) Souttar, 1934. (b) Hoot, Sinclair, and Smithers, 1952. (c) Henschke, 1954.



Fig. 3—Gamma-emitting seeds in nylon thread from Ohio State University.

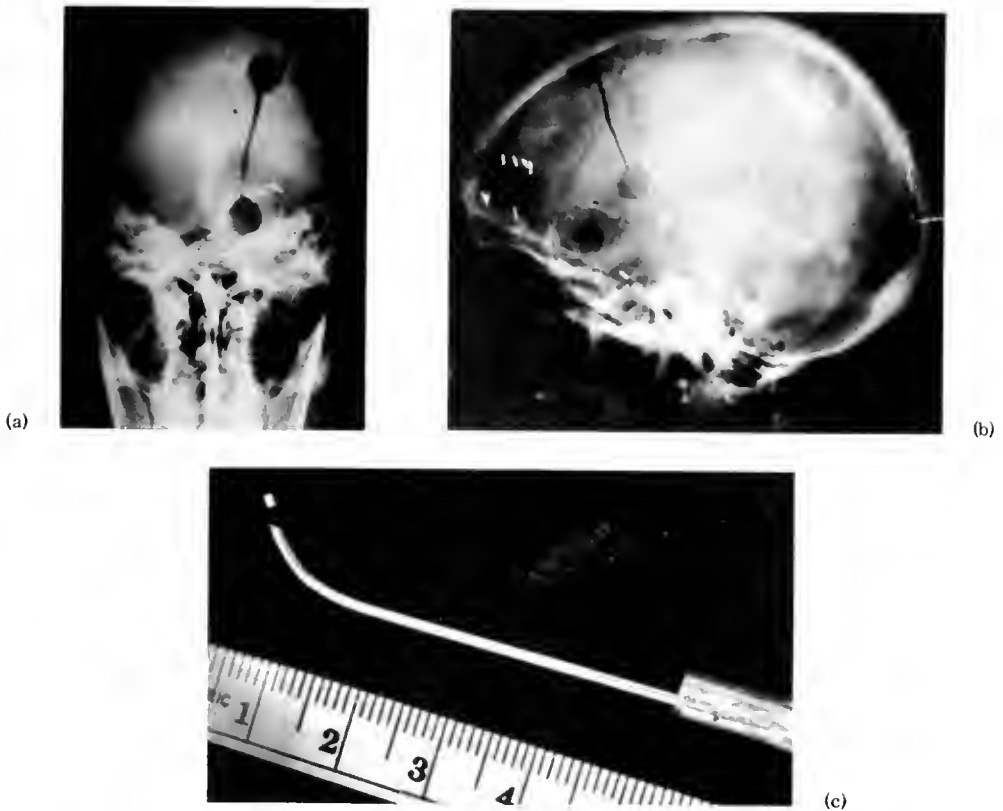
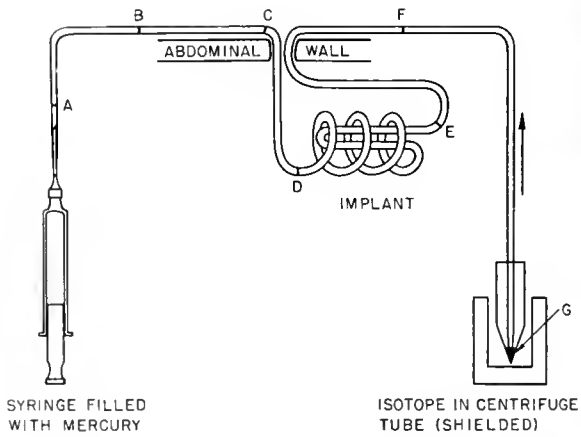
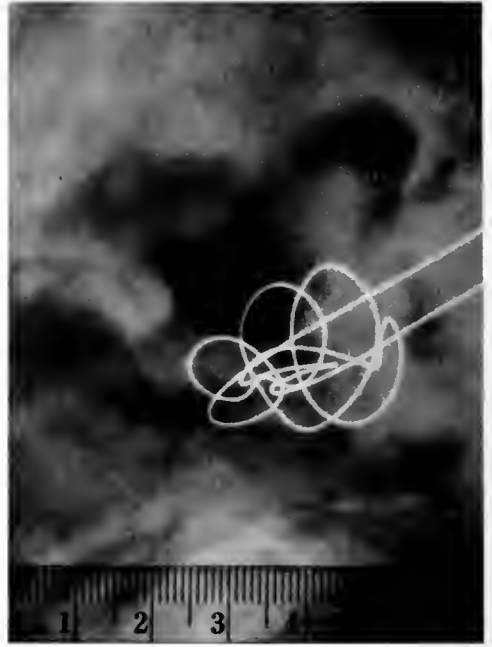

Fig. 4—Ceramic pellets containing Y^{90} used at the University of Chicago to irradiate the pituitary gland. (a) Anterior radiograph showing placement of pellets. (b) Lateral radiograph showing placement of pellets. (c) Pellet and applicator.



(a)



(b)

Fig. 5—Gamma emitters in nylon tubing from the University of Chicago. (a) Diagram of device. (b) Radiograph made by this method.

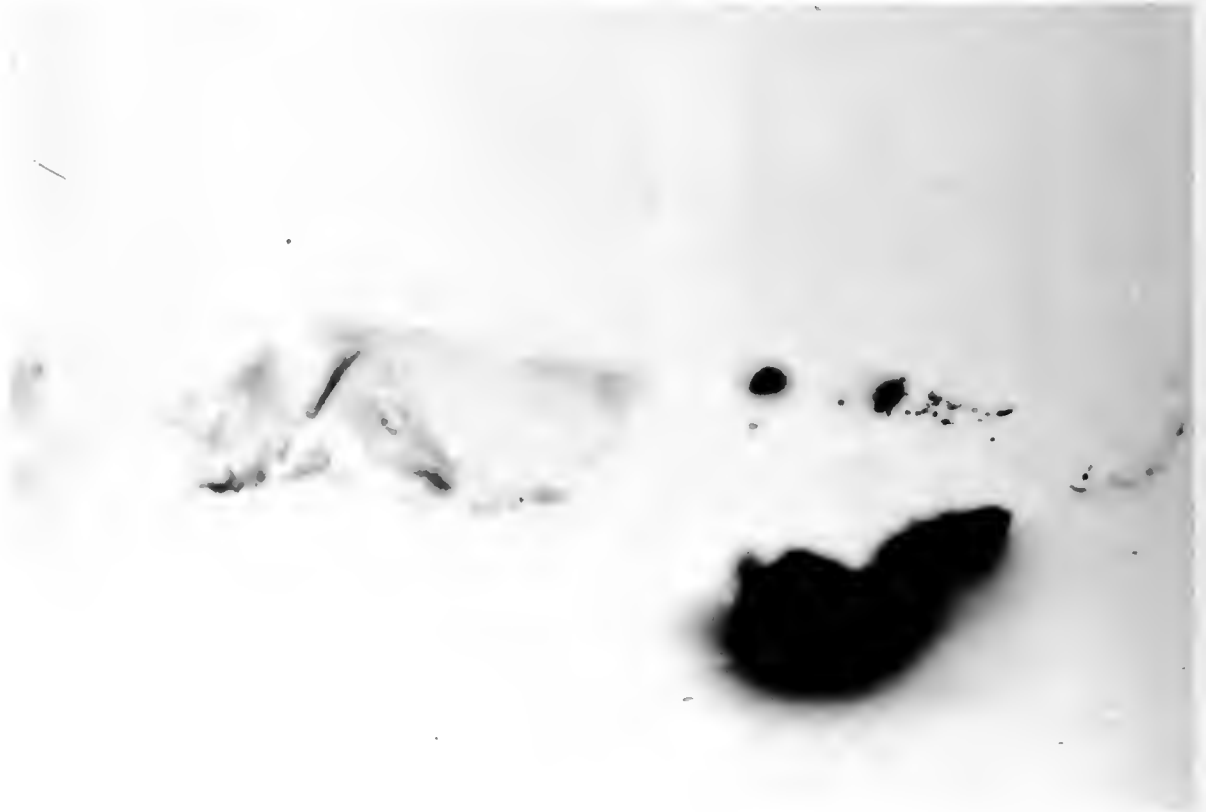

Fig. 6—Autoradiogram of the mediastinum of a dog after a sham operation for bronchiogenic carcinoma. The dark splotch on the lower right is from Lu^{177} in an implanted Gelfoam sponge.

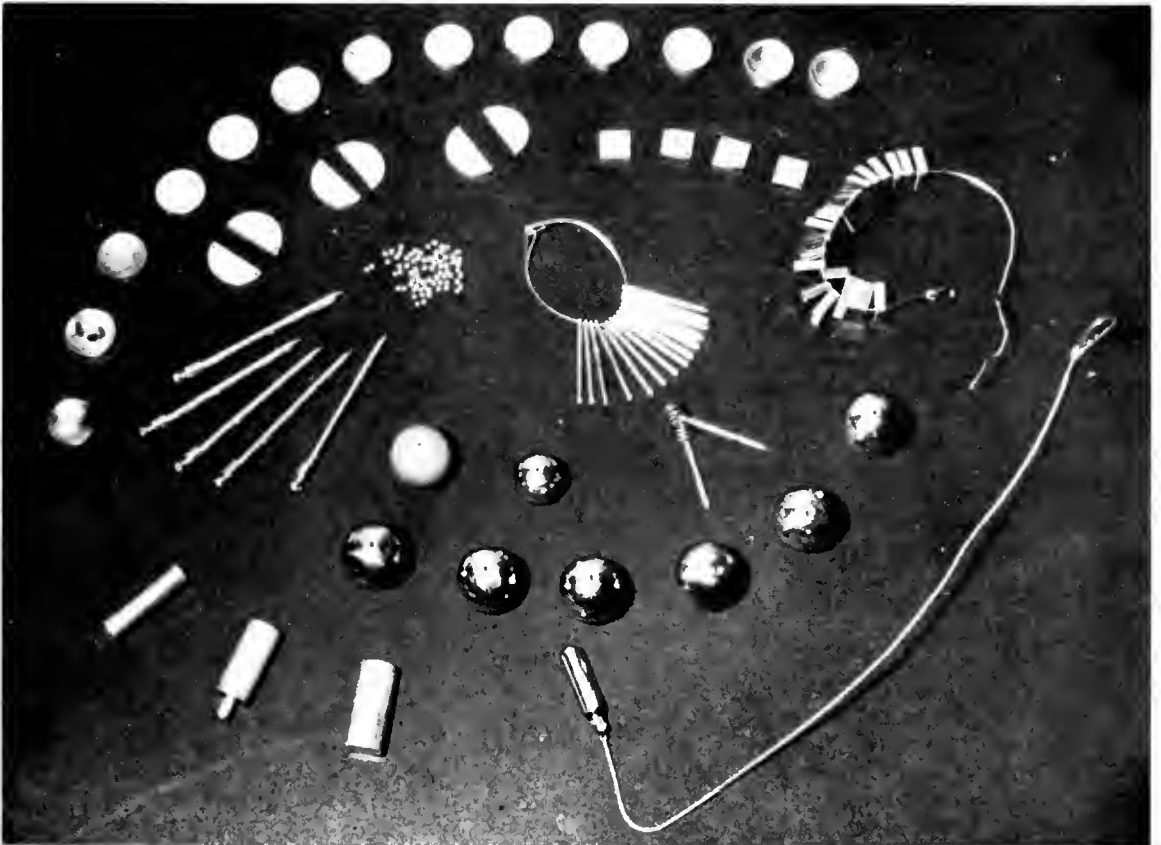
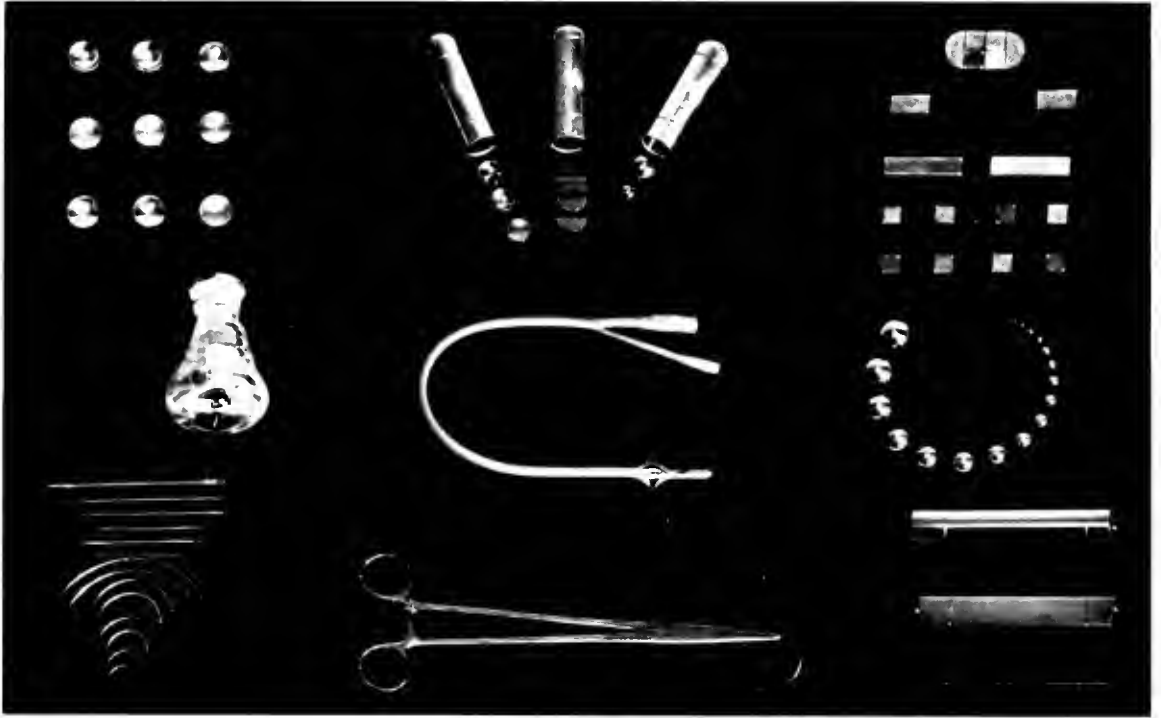

Fig. 7 — Devices made from International Nickel Co. Incoy alloy (Co⁶⁰).

came to Oak Ridge to investigate the use of surgical sponges. An autoradiogram of the complete flattened-out mediastinum of a dog is shown. The mediastinum was placed as close as possible to a piece of photo-

electron cloud around a radium needle. The machinist who makes the device gets no exposure to radioactivity. All these are significant advantages; however, there is still one disadvantage—one that

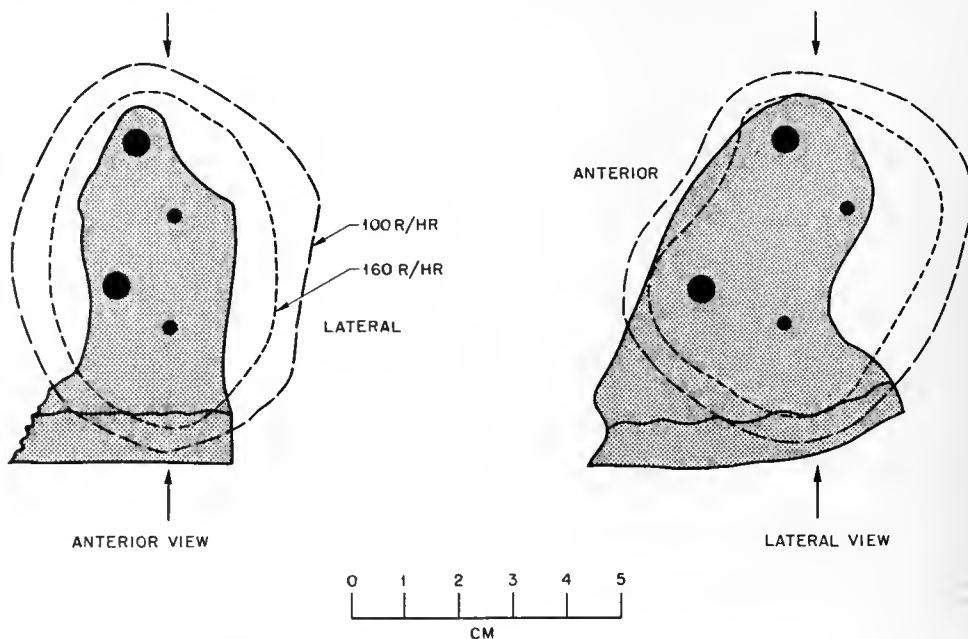

Fig. 8—Diagram of prosthesis used in carcinoma of the antrum, showing placement of Incorey Co^{60} beads.

graphic film. The surgeon first performed a thoracotomy on the dog as though he were to remove a lung cancer. After he removed the lung, he wrapped some surgical sponge, which had been dipped in Lu^{177} , around the lymph nodes in the dog's mediastinum. This was left in position for a few weeks, after which the dog was sacrificed to determine where the activity was. As can be seen from the figure, the activity stayed mostly in the Gelfoam sponge, but a considerable amount was picked up in the lymph nodes in the lymph drainage area.

Figure 7 shows another approach to the brachytherapy problem. A piece of stock metal is machined into almost any shape and is then put into a reactor. After a time in even a low-flux reactor, there is a significant amount of Co^{60} in the device since the metal is an alloy containing Co^{59} . When the devices are removed from the reactor, they are washed in nitric acid or aqua regia to remove all the reactor dust and the outer layer of cobalt. This material is then relatively corrosion resistant. Since the metal is a true alloy of nickel, chromium, and cobalt, the Co^{60} is uniformly distributed throughout the device except on the surface. There is actually less electron emission from the surface of these devices than there is from a radium needle. With this kind of brachytherapy device, we have accomplished a number of objectives. We have made a corrosion-resistant sealed source of an isotope. We have reduced the electron cloud around the device so that it is less than the



Fig. 9—Radiograph of skull with antral prosthesis in place, showing position of Incorey- Co^{60} beads. The intra-oral shadow is a metal ring used for distortion-correction calculations on the radiograph.

we must not belittle in brachytherapy devices. The radiotherapist still gets an exposure when he applies this kind of device to the patient.

Although it is difficult to predict how the cobalt beads will be used, one illustration by Dr. Friedman is shown in Figs. 8 and 9. Figure 8 is a diagram of a

prosthesis for the treatment of a patient with carcinoma of the antrum. The large black dots are 5-mm Incorey beads of 7.5 millicuries each; the small dots are 3-mm beads of 29 millicuries each. By relatively simple calculation of spherical isodose surfaces, the design of the positioning of the beads was made to reach certain remote areas containing residual dis-

level but not for teletherapy devices in the many curie levels of activity.

We think that cesium would probably be even more practical than europium in this kind of sealed brachytherapy source. However, we still do not know how to seal a cesium source in a practical economic manner. Therefore the europium devices are being



Fig. 10—Bowman-Gray applicator for $\text{Eu}^{152,154}$.

ease. Figure 9 is a lateral radiograph of the prosthesis containing the beads in the antrum of the patient. The intra-oral shadow is from a metal ring used for calculations of distortion correction on the radiograph. After two weeks of irradiation a homogeneous second-degree epithelitis was evenly distributed throughout the entire antrum.

Figure 10 shows Dr. Meschan's favorite cervix applicator. This one, however, is filled with europium, but it could have been filled with cesium or with any isotope. The advantage of using europium for this device is that, although europium has about the same energy as cobalt, it has a half life that is more than twice as long as that of Co^{60} . Dr. Meschan's cervix applicator with europium is a permanently sealed source of activity. Such a device would be far too expensive with radium; also there is no repeated loading exposure to the radiotherapist as there would be with radium. Since the europium has a 12.5-year half life, there will be a bookkeeping problem, which is a disadvantage. However, it is not so bad a bookkeeping problem as would have been true if Co^{60} had been used.

At one time the europium isotope was thought to be the answer to the teletherapy problem because we thought it could be made into a true point source and because it also has a half life significantly longer than that of Co^{60} . There is, however, a very great complication in the manufacture of radioactive europium. In the production of the radioactive europium, many daughter reactions use up neutrons at a terrific rate. This decreases the specific activity and cuts down the efficiency of production; therefore the europium isotope at the present time appears to be efficient for very small brachytherapy devices in the millicurie

used somewhat as a stopgap until we learn how to make sealed sources with cesium.

Figure 11 illustrates another group of devices made following a design from the Massachusetts General Hospital. A set of about a thousand of these beads has been made, and here again the europium isotope is used. To make these beads, we filled a stainless-steel bead with about 2 mg of europium-aluminum oxide powder. It was then sealed by a welding procedure in the cold state. The whole device was placed in the reactor, and both the europium and the shell became radioactive. Since the stainless-steel shell becomes very mildly radioactive and since most of the isotopes that are formed in the shell of the bead die out fairly rapidly, the device probably could be made very economically and without exposure to the manufacturer.

For each of these ideas I could have selected an example from almost any country, showing a different kind of an answer to the same problem. The point is that there is a resurgence of old ideas on the use of brachytherapy.

The devices we have chosen to make were those which our committee decided were the most practical at the present time. The committee has attempted to select devices that appear practical from both radiotherapeutic and economic standpoints. Since we do no therapy of this kind in Oak Ridge, all the devices we have made are being shipped to other radiotherapists for clinical trial.

Many other ideas could have been worked on; many of the devices we made might have been better, but we are only in the beginning of a brachytherapy program. The primary point is that we feel that "Uncle Miltie" Friedman should stop spending 24 hours a day

with that 2 million volt monster he has and start spending some time thinking of the simple therapeutic devices.

We are also showing many people a very small 1-mm-diameter bead. This bead contains so little

on a brachytherapy idea is that it is probably worth investigating if the idea will bring about an improvement in any way, in cost, time, protection, or flexibility. Radium is the index of comparison for any isotope used in brachytherapy. One other criterion,

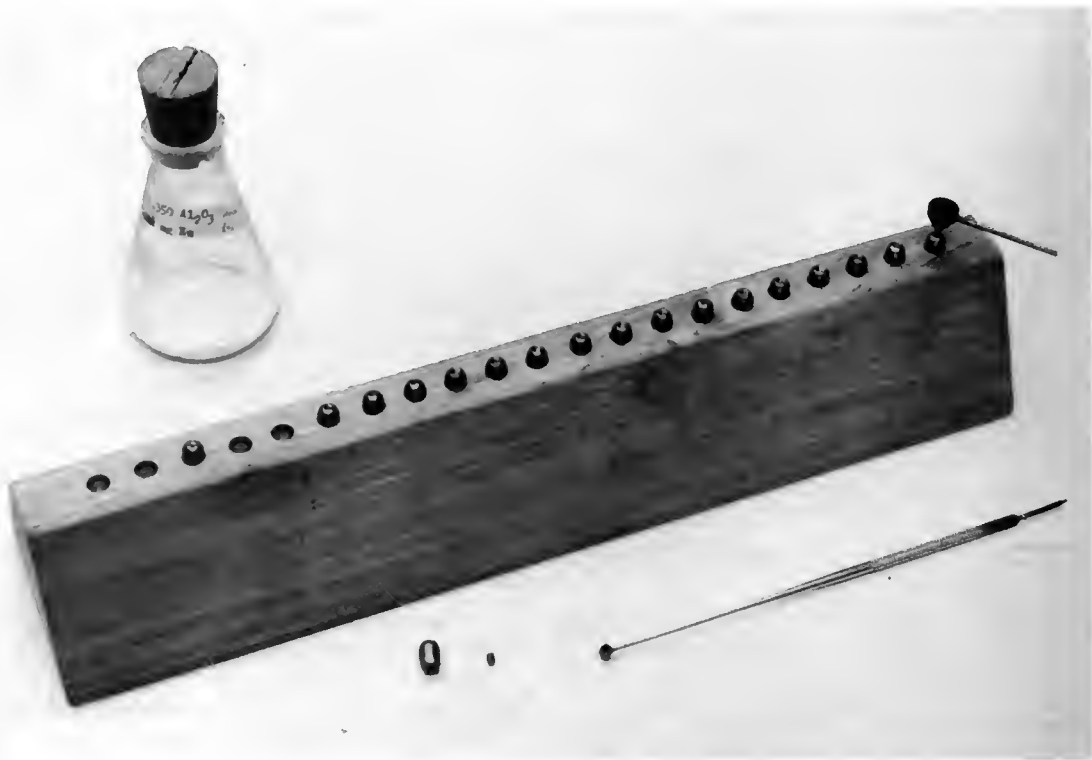

Fig. 11—Europium-filled beads designed for the Massachusetts General Hospital.

cobalt that the problem of getting a reasonable activity is a considerable one unless we use exceedingly high-flux reactors. We have decided to make a series of 1-mm corrosion-resistant beads just as a trick to prove that it can be done. The beads will probably have to remain in the reactor for a full year. Eventually, however, it is possible to get a millicurie of activity in each bead.

This is not a practical device by any means, but there is no reason why we should not do tricks to prove that we can do just as much as the English can do. With this exception, all the brachytherapy devices that we are making are, we think, the experimental approaches to what might be, in the future, practical brachytherapy devices.

I could continue with long, detailed descriptions of many other ideas being tried in this and other countries. However, we should summarize the criteria that we are using to determine whether a brachytherapy idea is or is not worth working on. Probably the first of the criteria used is one that has a long history. Radium has been used for brachytherapy for well over 50 years. Therapists have learned how to use radium and, to a large extent, have learned where and when to use it. Probably our first criterion for work

although included in the first, is of sufficient importance to be separately mentioned. This is the problem of protection. Four people must be protected in the application of brachytherapy devices: the manufacturer of the device, the person who prepares the applicator, the therapist, and the patient. Each of the examples I have shown and each new idea must be considered from the standpoint of the protection of each of these four groups of persons. The Incorey beads, for example, have no protection advantage for the therapist; but they do have some protection advantages for the patient, and they completely solve the problem of protection to the manufacturer and the preparator. The hollow nylon surgical thread solves almost all the problems of protection for all persons using the device. The Co^{60} modeling clay devised by Becker and Scheer adds to the problem of protection for all persons, and its advantages in therapy would have to be tremendous advantages for the device to become practically acceptable. Given a sufficient amount of time and money and a willingness to take certain risks, we can accomplish in Oak Ridge any trick means of therapy that you can think of. Our primary criterion, however, can best be stated in the form of a question, "Can the gadget be used to make a patient feel better?"

Szilard-Chalmers Reaction for the Manufacture of Brachytherapy Devices

CHAPTER 67

T. A. Chalmers

Radium Institute
Liverpool, England

When I saw the program for this meeting, I was puzzled by the meaning of the word "brachytherapy," which at first I thought was a "Brucerism." But Dr. Brucer has repeated the achievement of the philosopher in Molière, who, in discussing the difference between poetry and prose, convinced his opponent that he had been speaking prose for more than 40 years without knowing it. Dr. Brucer has convinced me that we have been using short-distance therapy, or brachytherapy, devices for years without realizing it.

We have been re-examining critically all the techniques with interstitial therapy, radium, and radon. Radon seeds have been used for some 40 years, and we therefore reviewed the catalogue of more than 700 radioisotopes for something that could possibly give us advantages over radon seeds. Radon seeds have a half life of 3.852 days, or an average life of 5.5 days. All the experience of the Manchester school seems to show that a longer term implant would be better.

On this basis we thought it might be desirable if we could find something with an average life of about 12 days to substitute for radon seeds. Out of this vast list of 700 isotopes, if two or three criteria are set, only one or two isotopes can be found which are capable of use. Although Au^{198} has been in use in the form of gold grains for some time, its half life of 2.7 days appeared to us too short.

A further disadvantage of radon seeds, as revealed by beta-ray spectroscopy, is that the 3.17-Mev beta rays are not completely suppressed. If the implant is about 1 mm in diameter, only 0.3 mm filtration of gold or platinum is left. This lets through about 30 per cent of the 3.17-Mev beta rays, producing some surface-tissue necrosis.

The next criterion, after the longer half life, is a lower energy beta-ray emitter. The half life of Au^{198} being too short, we turned up with three other isotopes, I^{131} , Ba^{140} - La^{140} , and Ag^{111} . The number of radon seeds used in the British Isles is about 1000 per week; therefore a substitute must be something that is easily

produced. This eliminates all neutron-deficient isotopes that have to be produced on cyclotron time; we must seek a fission product.

Fission I^{131} generated continually in all the nuclear reactors is in amounts of megamegacuries, and it can be extracted fairly simply; therefore we tried to devise a seed activated with I^{131} .

The project up to this time was a pipe dream. I presented it to Dr. Groves of the Radiochemical Center, Amersham, England, and he persuaded two of his colleagues to work on the scheme. They suggested silver filtration, canning the iodine silver. Silver iodide is fairly stable; you have been using it for years in your photographic emulsions. Once the iodine is fixed in the silver, only about 0.3 or 0.4 mm of silver filtration is needed to absorb the beta radiation. It has been found possible to make up iodine seeds of several millicuries. Very roughly, allowing for the K factor and the half life, about 2 millicuries of I^{131} canned in silver seeds is equivalent to 1 millicurie of radon. Furthermore, there is no practical limit to the specific activity, and it can be made up in curie sources.

A number of workers have, for some time, been convinced that the gamma-ray energy from radium was too high for differential absorption in intracavitary devices, particularly in devices for the treatment of carcinoma of the cervix.

G. J. Neary first used a screen to protect the rectum in cervix treatments and turned up with something very heavy indeed—platinum—because the half-value layer of radium gamma rays in lead is about 12.5 mm. We thought this lower gamma-ray energy of iodine could also be used for intracavitary devices.

Up to now R. C. Tudway and H. F. Freundlich of Bristol, England, have used Ir^{192} for this purpose. They are quite interested in this iodine because it is an expendable source, whereas iridium has a very high capture cross section and it is necessary to have two sources in the reactor, two in the safe, and two in

use. They would be quite interested in trying an expendable source.

There is a further feature of iodine seeds. So far we have had only preliminary animal trials to see whether they could tolerate the silver; it appears that the tissue reaction in the immediate zone of the seed is much less because there is not only complete suppression of beta rays but also, with the secondary filter of medium atomic number, there is lower

secondary-electron emission. It therefore appears that, in the preliminary trials in guinea pigs, we have something quite useful.

Furthermore, we can make up sources in silver tubes of about 1 mm diameter in lengths that can be bent into circles. They have uniform linear activity and can comply completely with the idealistic conception of the Parker-Paterson rules, which hitherto have had to be achieved in practice by discrete sources.

Use of Tantalum Wires

CHAPTER 68

Frank Ellis

Oxford United Hospitals
Oxford, England

The tantalum wires that we use were first described by W. K. Sinclair, formerly of the Royal Marsden Hospital and now in the U.S.A. Concerning the radioactive properties of tantalum wire, I shall say only that the energy of the radiation is similar to that from radium and that the wire can be obtained in any length, sheathed in platinum, so that there is little or no danger of contamination by radioactive particles. The wire is activated in the pile.

The platinum becomes radioactive in the pile; but its radioactivity very soon wears off, and the tantalum can be used quite safely. It has the advantages that it can be obtained in any length, that it is active along its whole length, and that it is flexible. The difficulty is that the wire is so flexible that it cannot be introduced as can a radium needle. I have therefore devised what I call "split needles," illustrated in Fig. 1. These are slightly curved serum needles with the concave side cut out so that tantalum wire pushed into the serum needle can be displaced laterally into the tissues by a stylet, after which the split needle and stylet are removed together. This technique can be used with any length of wire up to 12 cm.

Another way of inserting tantalum wire, especially to reach quite deep into the tissues, is to use a thin nylon tube containing the tantalum wire; the nylon tube might be any length, with the necessary length of tantalum wire at one end of the nylon tube. This is introduced through a hollow needle of adequate length.

I shall present some figures illustrating methods that have been successful. They are not all concerned with tantalum wire, but they illustrate interesting cases.

Figure 2 is a radiograph of a device in position for treatment of a carcinoma of the bladder, infiltrating the muscle; Fig. 3 shows the lateral view. The difficulty in treating carcinoma of the bladder is in getting a theoretically ideal implant. The device looks to be a fearsome thing. It is made of brass tubes containing tantalum wire, with prongs that go right through the bladder wall so that one plane lies

inside the bladder wall and is held firmly in relation to another plane outside the bladder wall.

Much to my surprise, the patient was symptom-free while this was in position. The discomfort was small compared, for example, with that from a balloon. I can only assume that this was because the device did not distend the bladder and therefore did not cause spasm.

The disadvantage is that the bladder must be opened to remove the device. In this case—we have used it in only one—when examined by cystoscopy two months ago, the patient's bladder wall looked normal; it was almost impossible to tell where the carcinoma had been.

Figure 4 illustrates a melanoma of the iris before treatment. Figure 5 shows the effect after treatment by implanting tantalum wire. The tantalum wire was inserted in two hypodermic needles, one passing through the sclera and the other entering through the cornea, just passing through the iris and coming out through the cornea. Figure 5 was made 18 months after treatment; the cornea is transparent enough for a photograph to be taken through it. The lesion here is smaller than it was originally. The iris is somewhat distorted.

This method was used because the patient's other eye had been removed previously for another reason. Unfortunately, during treatment of the melanoma the surface of the lens was scratched. The patient developed a traumatic cataract and had to have an extraction of the lens. However, she can see to read, and therefore we feel that the treatment has not been wasted.

Figure 6 shows tantalum wires, with an eyelet for threading, which were used in treatment of a small rapidly increasing melanotic lesion on the conjunctival surface in a boy 15 years old. The lesion has completely disappeared. I feel that this was a good method of treatment because it caused no complications.

Figure 7 shows tantalum wires, inserted with split

needles, and used as hairpins. The patient was a man with a growth involving the floor of the mouth, alveolus, and cheek; he was treated two years ago. He now has

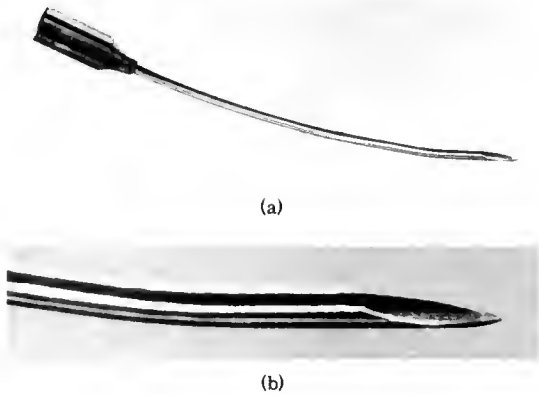

Fig. 1—(a) Split needle. (b) Detail of the pointed end of the split needle.



Fig. 2—Radiograph of a device in position for treatment of a carcinoma of the bladder.



Fig. 3—Side view of the device shown in Fig. 2.



Fig. 4—Melanoma of the eye before treatment.



Fig. 5—Eye shown in Fig. 4, 18 months after treatment by implanting tantalum wire.



Fig. 6—Tantalum wires, with an eyelet for threading, used in the treatment of a small rapidly increasing melanotic lesion on the conjunctival surface.

a small diminishing patch of ulceration on the alveolus, but he has had no pain and feels quite well. The necrosis, which was relatively superficial, is still improving.

The tantalum-wire hairpins straddled the alveolus; apart from a combination of radiation and extensive surgery, we do not think we could have achieved the same result with the apparatus we have.

Figure 8 is a radiograph of tantalum wire in nylon tubing sewed around an epithelioma of the lip and

cheek. There are two cylinders of different diameters. The tantalum wire was all of the same strength, and so the cylinder of smaller diameter was cut off and removed at an earlier time than the rest; thus the proper dose was delivered to both lesions. The result is perfect.



Fig. 7—Tantalum wires, as split needles, used as hairpins.

Figure 9 represents the use of Perspex (lucite) beads containing radium needles (I think radium comes into this because it is a supervoltage type of isotope). This is a technique for treating carcinoma of the antrum when the patient has had previous irradiation. The patient had proptosis. Previous irradiation had been given with a cobalt bead on the end of a steel rod inserted through the canine fossa up to the region of

proved. The antrum was cleared out surgically. We then treated the walls of the cavity with Perspex ovoids, inserted higgledy-piggledy but giving an al-

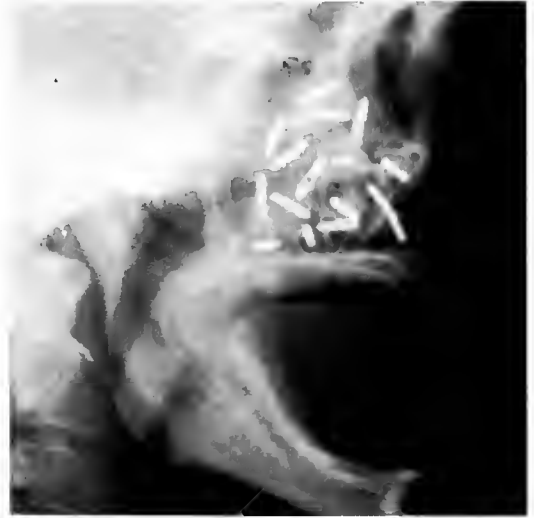

Fig. 9—Perspex (lucite) beads containing radium needles used in treating carcinoma of the antrum.

most uniform dose to the walls of the cavity. She is well after three years and has good vision.

Figure 10 shows a new technique, which I do not recommend. This patient was treated about two years ago for a postcrioid carcinoma by this method so that, in case of a recurrence, pharyngolaryngectomy would be possible without delayed healing of the skin. This was the first case so treated and is the only



Fig. 8—Radiographs of tantalum wire in nylon tubing sewed around an epithelioma of the lip and cheek.

the ethmoid. The cobalt was withdrawn to certain positions for different lengths of time to produce a pear-shaped volume of radiation. The proptosis im-

postcrioid carcinoma thus treated successfully. The patient's neck was opened, and a long hollow needle was inserted anteriorly to one carotid, between the

esophagus or pharynx and the vertebral surfaces; it then came out through the other side anteriorly to the carotid. Vertical needles were also inserted internally



Fig. 10—Long hollow needles used in the treatment of post-cricoid carcinoma.



Fig. 11—Radium needles used in treating intrinsic carcinoma of the larynx.

to the laryngeal cartilages to provide the dose anteriorly. Recently, on esophagoscopy, there was no sign of carcinoma; she can now swallow quite well.

We have not been successful with the other post-cricoid carcinomas; they have all recurred. Posterior pharyngeal-wall carcinomas have responded well to this method.

Figure 11 shows an unusual radium technique. It aims to treat intrinsic carcinoma of the larynx by insertion of needles between the deep perichondrium of the thyroid cartilage and the cords; thus nothing interferes with the blood supply of the cartilage. Small holes are drilled in the thyroid cartilage on the

opposite side of the mid-line to the lesion, and the radium needle is inserted by sliding its point along the deep aspect of the thyroid cartilage. It is extraordinarily easy to put the needles in the right position, and the radiation is kept very close to the volume to be treated. The treatment is extraordinarily free from complications.



Fig. 12—Tantalum wire and radium used in treatment of carcinoma of the anus.



Fig. 13—Carcinoma of the anus with radium needles along the lumen and tantalum wires following the contours of the tissues.

We have treated many such cases, and they have all done well, except one or two treated in the early

days which had extension backwards onto the arytenoids. If the growth reaches the arytenoids, this method (especially having in mind the inactivity of the ends of the radium needles) is not satisfactory. Two patients developed recurrences.

She has left England for India, but she wrote to me two months ago, saying she was quite well.

Figure 14 shows my brachycurietherapy device for treating carcinoma of the cervix. This is an ordinary uterine tube, used in association with radium capsules

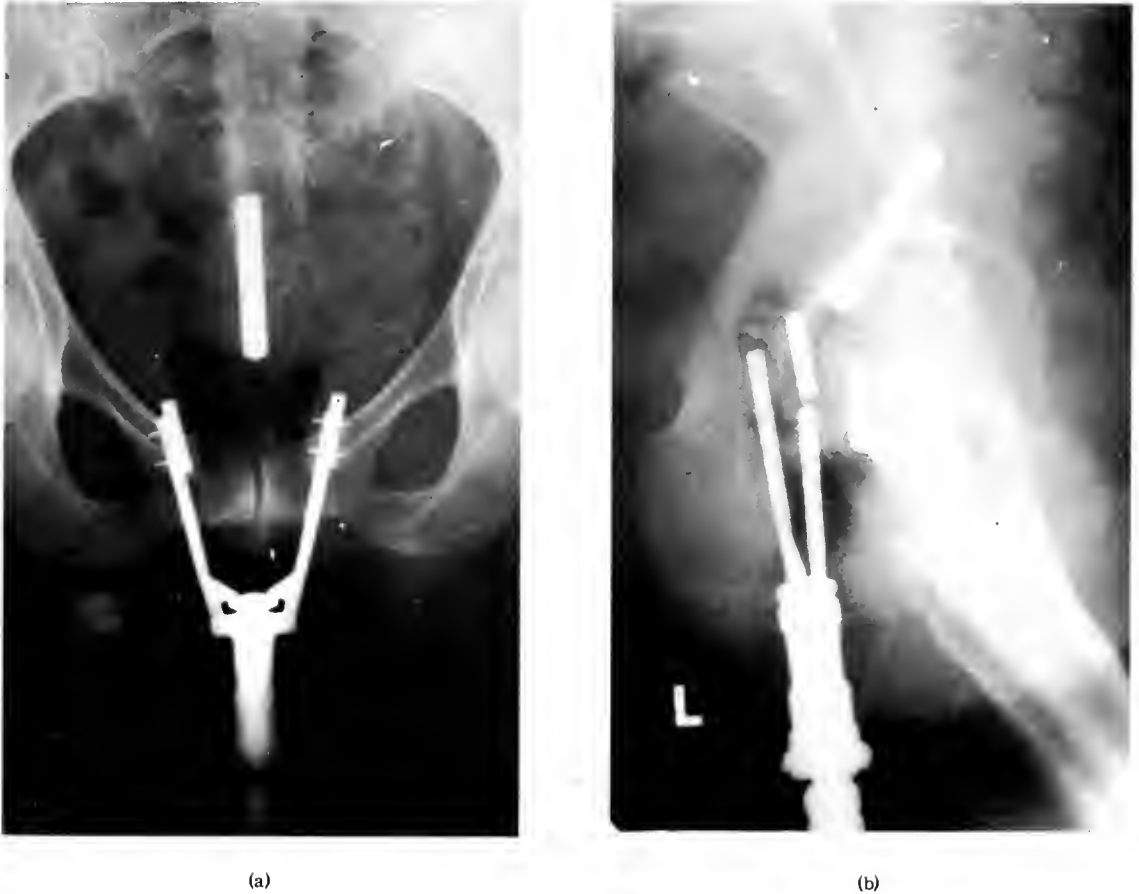

Fig. 14—(a) Brachycurietherapy device for treating carcinoma of the cervix. (b) Lateral view of the device.

Figure 12 indicates a situation in which tantalum wire is very useful. This patient had a carcinoma of the anus extending into the lower part of the rectum. It was treated with radium in the lumen of the anus, and tantalum wires were inserted on nylon tubing through tubular needles to produce a good geometrical distribution. It is not so perfect as desired; preferably the radium should be lower down; but I assure you the result is quite perfect. No evidence of carcinoma of the anus can be seen. In such cases radium needles are not so successful; they are rigid, and, no matter how carefully one tries to insert them, they always seem to diverge away from the lower end, producing a very poor distribution and, in my experience, bad results.

Figure 13 shows another case of carcinoma of the anus, and again radium needles along the lumen and tantalum wire following the contours of the tissues, producing quite a good distribution, can be seen. This patient was treated two and one-half years ago.

in the vagina. We can adjust the width and can estimate the relative distance distribution of vaginal and uterine sources and thus calculate the doses at various points that are relevant to the treatment.

Figure 15 shows a patient who had a massive recurrence on the pelvic wall after Wertheim's operation for carcinoma of the cervix 18 months before. The recurrent mass caused pain and swelling of the leg. She was very obese, and, since I have only 250,000- and 300,000-volt apparatus, I put tantalum wires directly into the pelvis from the perineum without exposing the patient to surgery. With a finger in the rectum to make sure of not penetrating it, I could feel the mass and could insert the needles along which the tantalum wire in nylon tube was passed. The mass disappeared. It has been 18 months since this treatment, and the patient is perfectly well.

Figure 16 shows radium needles inserted into the neck to treat nodes in the neck secondary to carcinoma of the thyroid. This case illustrates a point. The



Fig. 15—Tantalum wires used to treat a massive recurrence on the pelvic wall after Wertheim's operation for carcinoma of the cervix.

patient was a 19-year-old girl, recently married, with carcinoma of the thyroid. She had had partial thyroidectomy and was sent to me for an opinion about treatment. She had a papillary adenocarcinoma that took up I^{131} . Between the operation and my consultation, a node appeared in the upper deep cervical group, and shortly thereafter another node appeared.

What was the best treatment? I was against additional surgery because partial surgery might have



Fig. 16—Radium needles inserted into the neck to treat nodes secondary to carcinoma of the thyroid.

left cells in the neck and a further radical operation was unlikely to be successful. Radioactive iodine might sterilize her or cause severe genetic damage to the germ cells, and therefore we did not use iodine. We treated the neck with X rays and then implanted radium needles into the residual lymph nodes. More than two years have passed since she was treated; she has had a normal infant since then and is well, with no sign of tumor.

A Bead-handling Device

CHAPTER 69

Stanley H. Clark

Cedars of Lebanon Hospital
Los Angeles, California

When Dr. Brucer first showed us these cobalt brachytherapy sources, I realized that we would need some special handling devices. The ideas presented here may be useful for handling other similar sources. The technique involves a vacuum method of handling radioactive sources composed of a nonmagnetic nickel-cobalt alloy.

One other thing that we have done is to put the large beads, those 1.5 cm and 2 cm in diameter, in the end of a mushroom catheter for use in intracavitary work. They fit nicely in the end of the catheter, which makes a useful applicator for the prostate; I believe that we have also used it in a bladder case. It is possible to put the beads through the slits in the end of the mushroom catheter.

[From this point on, the original narrative was in conjunction with a motion-picture film. This film demonstrated the use of the vacuum threader and the various vacuum handling devices that are presented here as single illustrations.]

Figure 1 shows the vacuum threading device. It has a two-position control device (not shown) for controlling the vacuum to the threading device and to the handling device. The underside of the threader is seen in Fig. 1. A light source shines up through the holes of the vacuum threader so that one can tell in which position to thread them. The alignment of the hole in the vacuum threader with the hole in the bead is accomplished fairly easily by rotating the bead (in position) with the rubber-tipped handling device until light becomes visible.

The device pulls a vacuum on the the needle channel. [This process, shown in the film, cannot be reproduced in the printed context.] A channel has been machined in the top of the vacuum threader to allow vacuum threading of radium needles, as well as cobalt sources. (This machining operation was accomplished after Fig. 2, the device as it appears from the top, was made.)

The position of the vacuum control lever is changed for the handling device. The actual vacuum is con-

trolled by the thumb (Fig. 3). When the thumb is on the hole, a vacuum is pulled through the hole. There is, in addition, a small clip device (Fig. 4), which is controlled by the finger. Figure 5 shows a cobalt-alloy disk being picked up to demonstrate that it is truly a vacuum pickup. Quite heavy objects can be picked up. The vacuum pump is a small commercially available laboratory type.

The handling devices are made in peculiar shapes and are counterbalanced to go around the edge of the 4-in. lead shield (Fig. 6).

In Fig. 7, we are looking through a tank of 9 in. of zinc bromide solution and 0.5 in. plate glass on either side. An angular view of this same shield is shown in Fig. 6. Figure 7 shows a display of brachytherapy cobalt sources. The camera is directed down through the zinc bromide tank, giving an idea of the clarity of vision through the tank. The idea was to have complete visibility of everything we did in handling our interstitial and intracavitary sources.

As the motion-picture film started, we were looking down through the tank (Fig. 7). We were preparing to pick up the first 5-millicurie bead. We put it in the top of the vacuum threader and twisted it around with a bit of rubber on the tip until we saw light through the hole from above (Fig. 2). The thread went down into the hole. At this point we were demonstrating the threading of two beads on the same thread to show how the threading of more than one bead was managed.

The film showed the second bead being picked up. We had the string (Fig. 4) in the little clamp that is controlled by the finger. Twisting the bead around until we could see light, from directly above through the tank, through the hole, we then moved the end of the thread over so that the vacuum could pull it through the hole; and we had two beads on the thread.

The film showed that one can kick them off, release the vacuum, and pull the thread out easily; otherwise the thread would go all the way into the vacuum pump. Screens in the vacuum lines now prevent such mishaps.

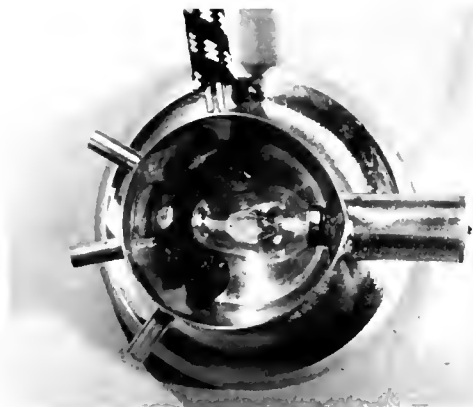

Fig. 1—Vacuum threading device as it appears from the underside. The light source illuminates the threading holes for alignment of the sources before threading. Note the glass elbows in each vacuum line, which allow light transmission.

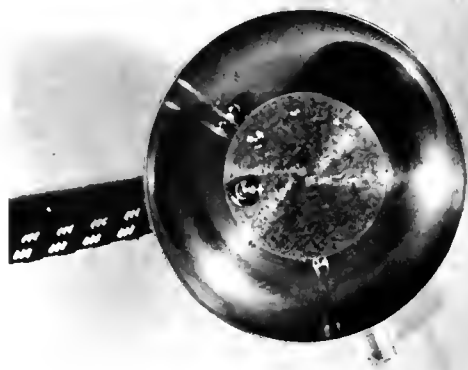

Fig. 2—Vacuum threader as it appears from the top. The circular catch tray prevents spillage of the sources in the course of threading. Note the light illuminating the threading hole.



Fig. 3—Vacuum pickup device with thumb-operated clamp for holding the thread during threading. Projection is a counterbalance.



Fig. 4—Vacuum pickup device showing how the thread and the spherical sources are handled.

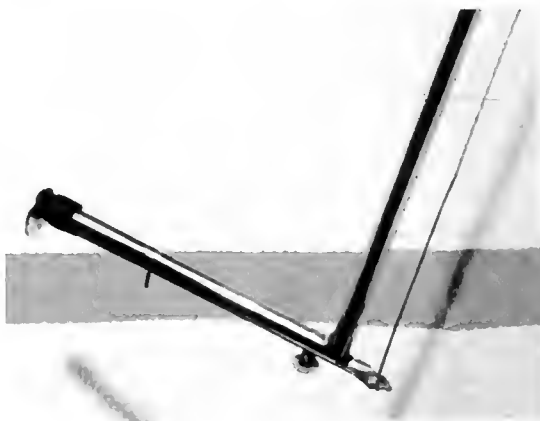

Fig. 5—Vacuum pickup device shown holding a Co^{60} -alloy disk source.

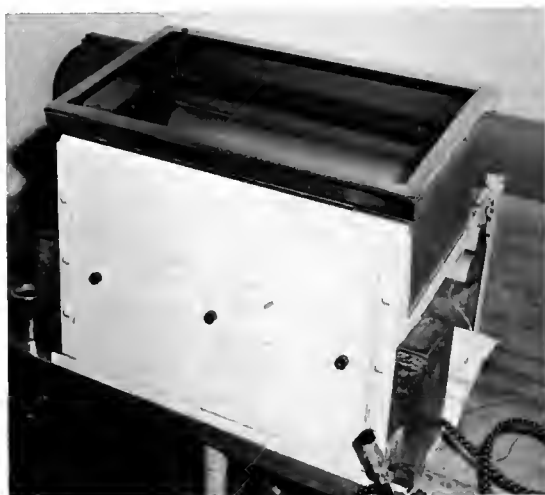

Fig. 6—Zinc bromide viewing tank and associated shielding. Note vacuum control lever in lower right-hand corner.

A BEAD-HANDLING DEVICE



Fig. 7—A view of a variety of brachytherapy Co^{60} sources through the 9 in. of zinc bromide solution and 1 in. of plate glass.



Fig. 8—A view of the vacuum threader, showing the way a Co^{60} disk is positioned before threading. Note the spherical sources in the catch tray.

The needle eyelet was seen again from above, with the light source underneath shining up through a glass tube. The thread was a little large; I had to use white thread in order to make it show up in photography. Otherwise one would use black nylon.

At this point the thread is sucked down into the hole (Fig. 2). All this was handled without any radiation exposure whatsoever; 4 in. of lead in front of the operator and 10 in. of 2.6 g/cm^3 zinc bromide and glass provided the protection.

Figure 8 shows the threading of the disk. The hole, which originally had been made for the disks, was the one used for the channel that came up flush with the

surface. The one used now has a slight conical opening so that it is not quite optimal for threading, i.e., it is not flush with the top surface of the threading device right up to the edge of the disk hole. Nevertheless, it is possible to thread the disks quite easily.

Acknowledgment

Acknowledgment is due Dr. Gordon Locker, Western Radiation Laboratory, Los Angeles, California, for the construction of all the handling and threading devices and for contributing his ideas in the course of their development.

APPENDIXES

ISODOSE CURVES

Isodose curves for use with the hectocurie Co^{60} teletherapy units are not included among the appendixes because they are available in another publication:

M. Brucer, Teletherapy Design Problems. IV. Isodose Charts for the Co^{60} Hectocurie Teletherapy Machine, Report ORINS-10, Mar. 15, 1955; available from the Office of Technical Services, Department of Commerce, Washington 25, D. C., \$0.75.



Cobalt Isodose Patterns for Moving Beams

APPENDIX A

Carl B. Braestrup and Richard T. Mooney

Francis Delafield Hospital
New York, New York

A multitude of techniques are available with rotating cobalt equipment because of the many variables (field size, arc of rotation in speed of source, etc.). In order to adjust these factors to obtain the optimum isodose pattern in a given clinical case, it is essential to know the effect of each. To determine this basic relation, a number of complete isodose patterns were prepared.

The effect of variation in speed of source on the resulting isodose pattern has been reported.¹ The isodose patterns shown here indicate the variation of both the arc of rotation and field size. The individual isodose patterns are based on ionization measurements in a water phantom with stationary beams, using a method of calculation previously described.²

The patterns shown were established for a 32- by 46-cm elliptical contour. The same isodose patterns may be applied to a family of similar contours, varying from each other by a fixed radial increment in all directions (Fig. 1). The ratio of the tissue to the air exposure dose at the center is, of course, depend-

ent upon the dimensions of the contour; it is tabulated in the lower left corner of the isodose pattern. An absorption scale similar to that shown in Fig. 2 was used to obtain the ratio.

The effect of variation in the arc of rotation on the resulting isodose pattern is shown in Figs. 3 to 7 for a 15- by 15-cm field. Figures 8 and 9 show the patterns obtained with a 6- by 15-cm field. A comparison of Figs. 7 and 9 indicates the major effect of field size in rotation therapy.

References

1. C. B. Braestrup and R. T. Mooney, Physical Aspects of Rotating Telecobalt Equipment, *Radiology*, 64: 17-27 (January 1955).
2. C. B. Braestrup and R. T. Mooney, Cobalt 60 Teletherapy Isodose Patterns for Combined and Non-Uniform Longitudinal and Transverse Source Motions, International Conference on the Peaceful Uses of Atomic Energy, June 1955.

ISODOSE CURVES

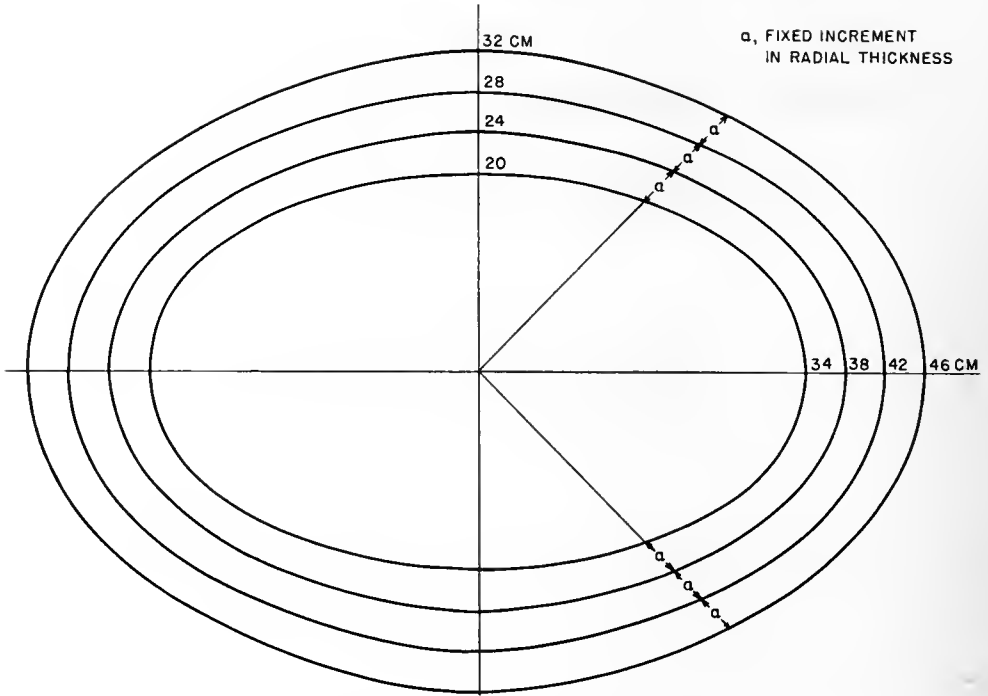

Fig. 1—Contours of patients having the same isodose pattern.

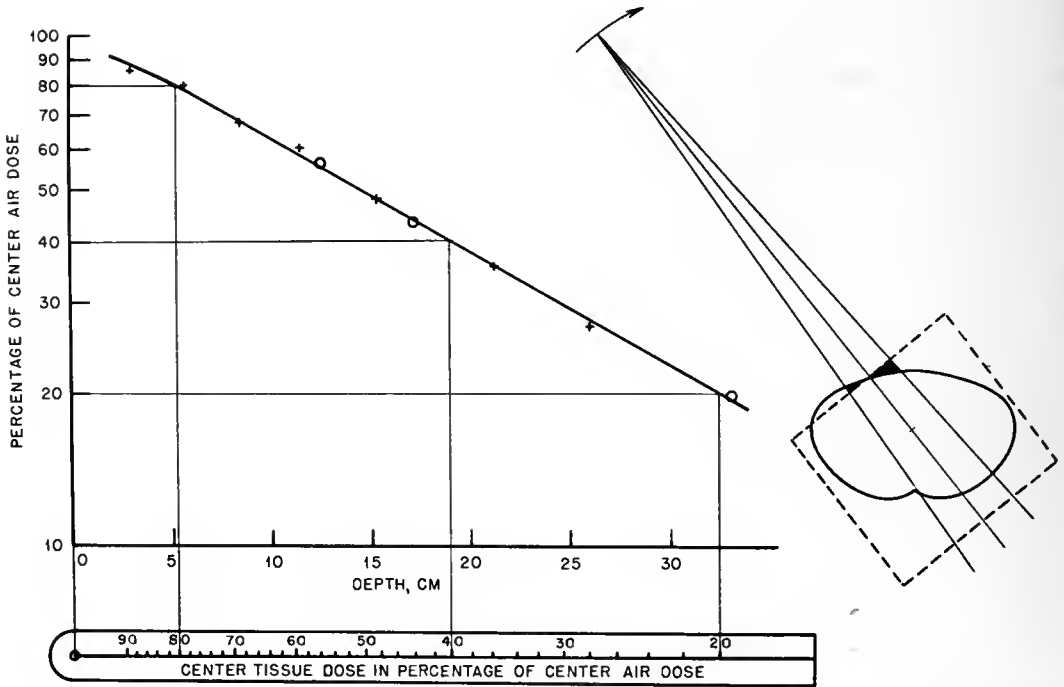
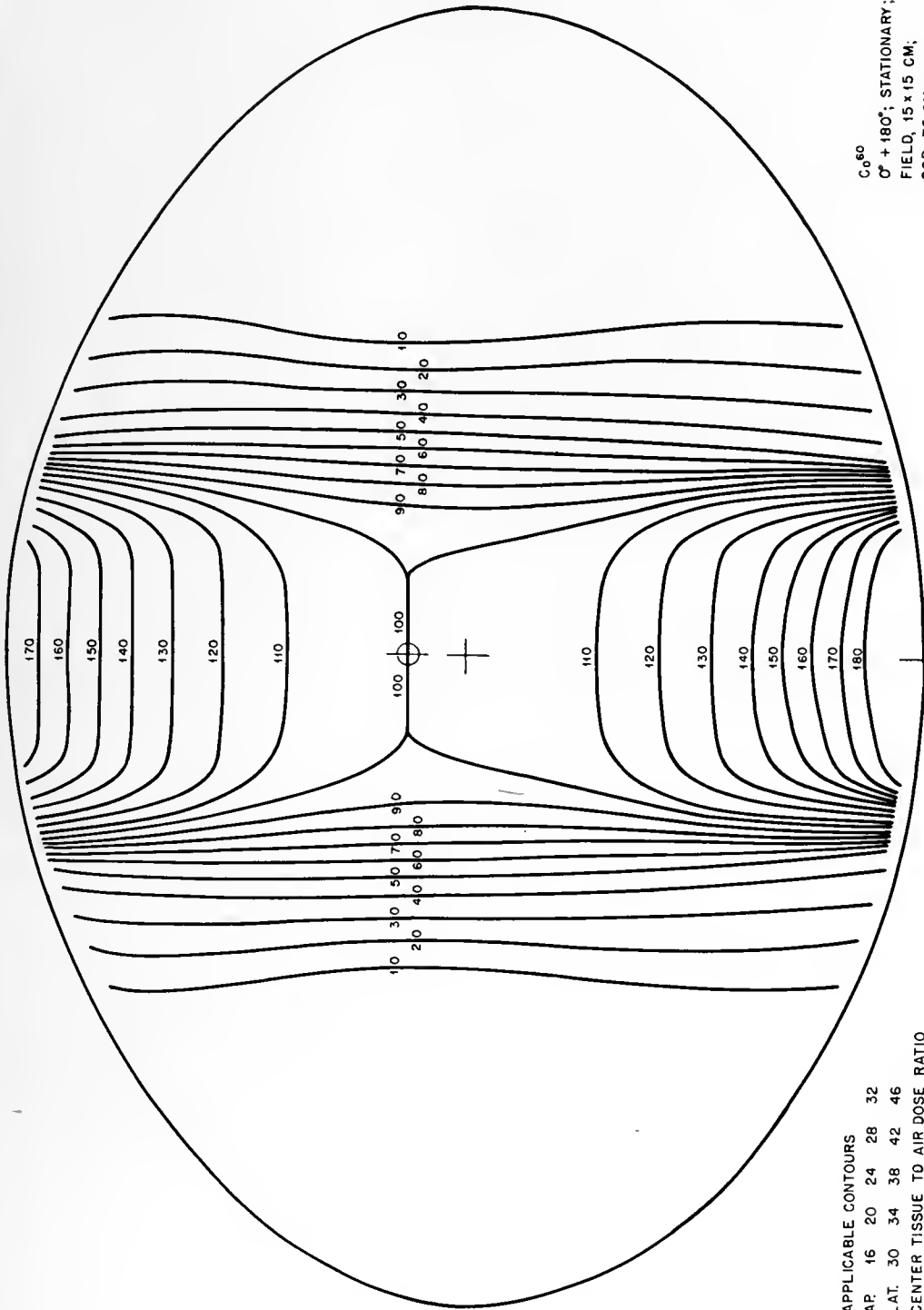

Fig. 2—Relation between center dose and tissue thickness. +, 30- by 30-cm phantom. O, contour phantom. The same absorption is obtained with both phantoms owing to compensating effect of shaded areas. The field was 10 by 10 cm at 75 cm.

COBALT ISODOSE PATTERNS FOR MOVING BEAMS



APPLICABLE CONTOURS
 AP. 16 20 24 28 32
 LAT. 30 34 38 42 46
 CENTER TISSUE TO AIR DOSE RATIO
 0.79 0.72 0.65 0.59 0.54

$C_{0.60}$
 $\theta + 180^\circ$; STATIONARY;
 FIELD, 15 x 15 CM;
 SCD, 75 CM;
 CENTER (0, +2)

Fig. 3.

ISODOSE CURVES

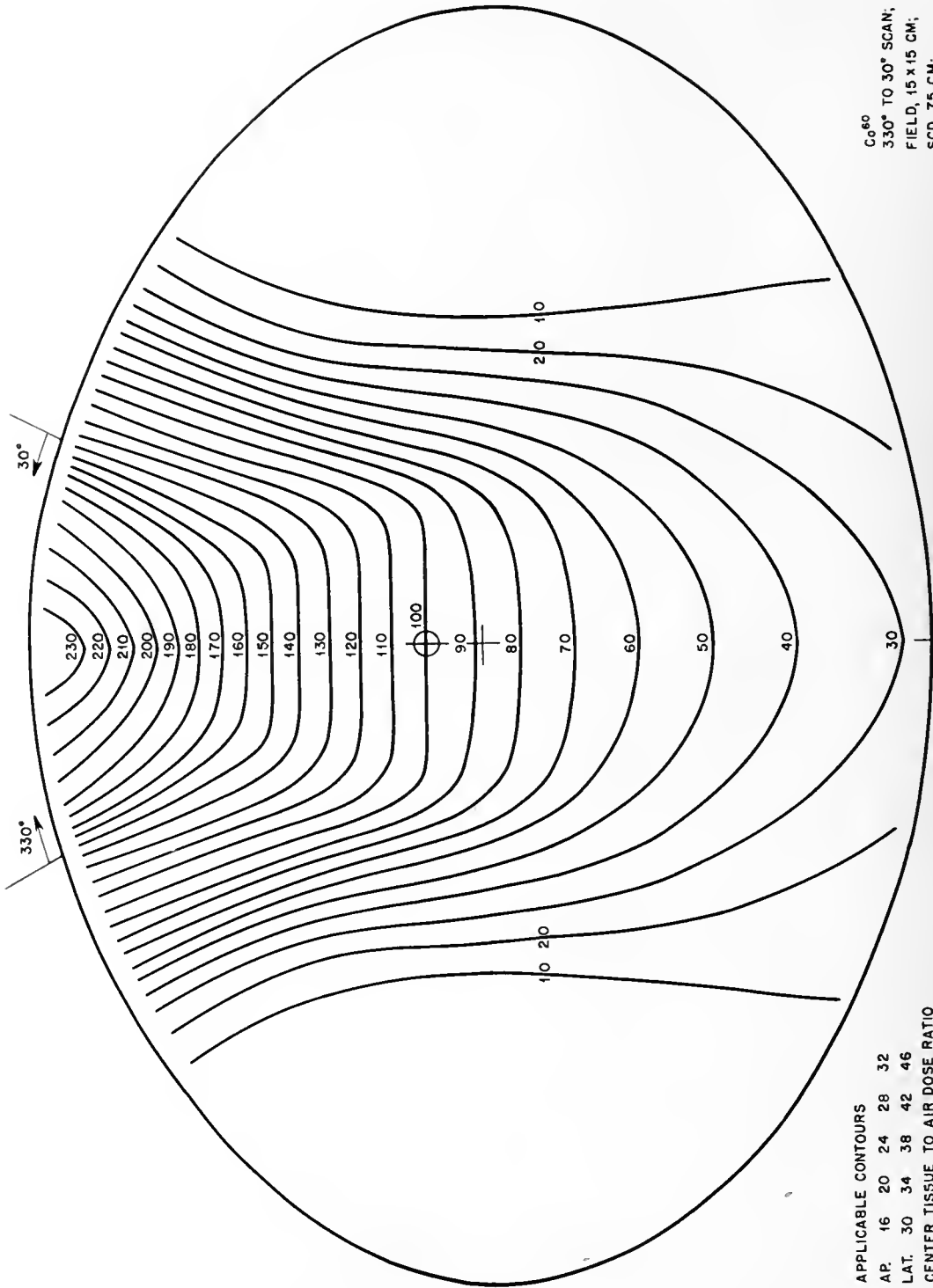

Co⁶⁰
 330° TO 30° SCAN;
 FIELD, 15 X 15 CM;
 SCD, 75 CM;
 CENTER (0, +2)

APPLICABLE CONTOURS
 AP. 16 20 24 28 32
 LAT. 30 34 38 42 46
 CENTER TISSUE TO AIR DOSE RATIO
 0.85 0.78 0.70 0.64 0.58

Fig. 4.

COBALT ISODOSE PATTERNS FOR MOVING BEAMS

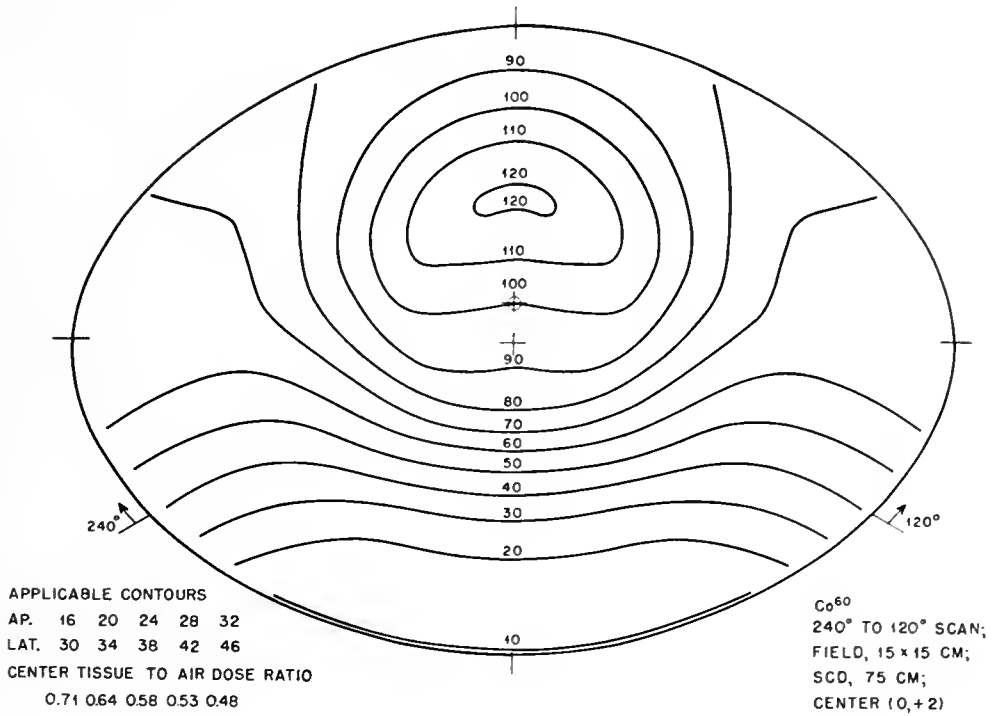

Fig. 5.

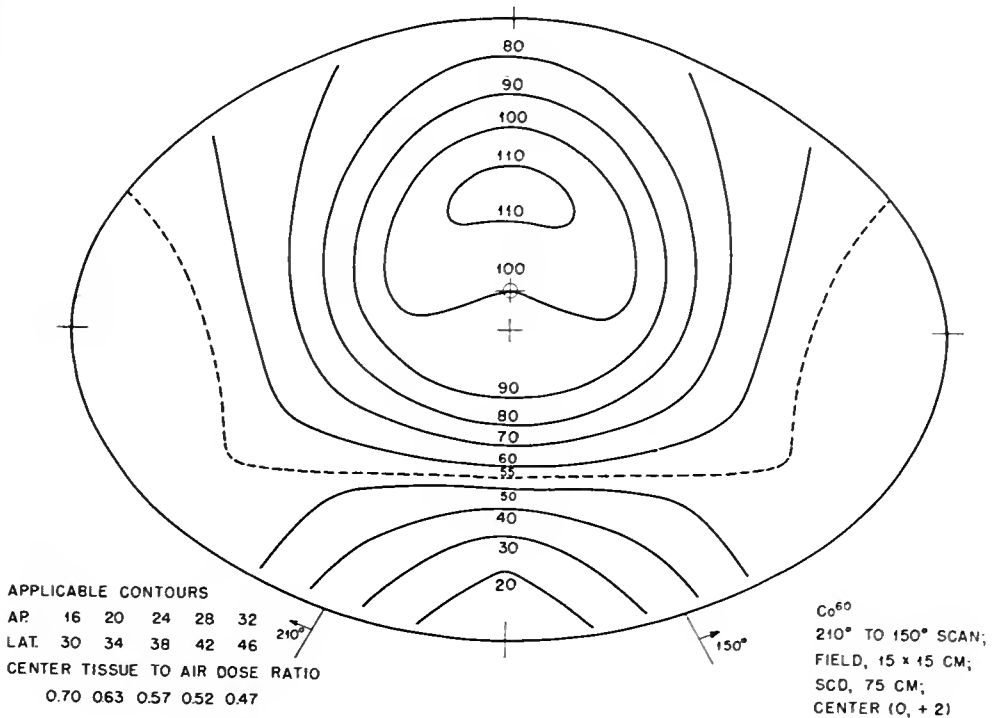

Fig. 6.

ISODOSE CURVES

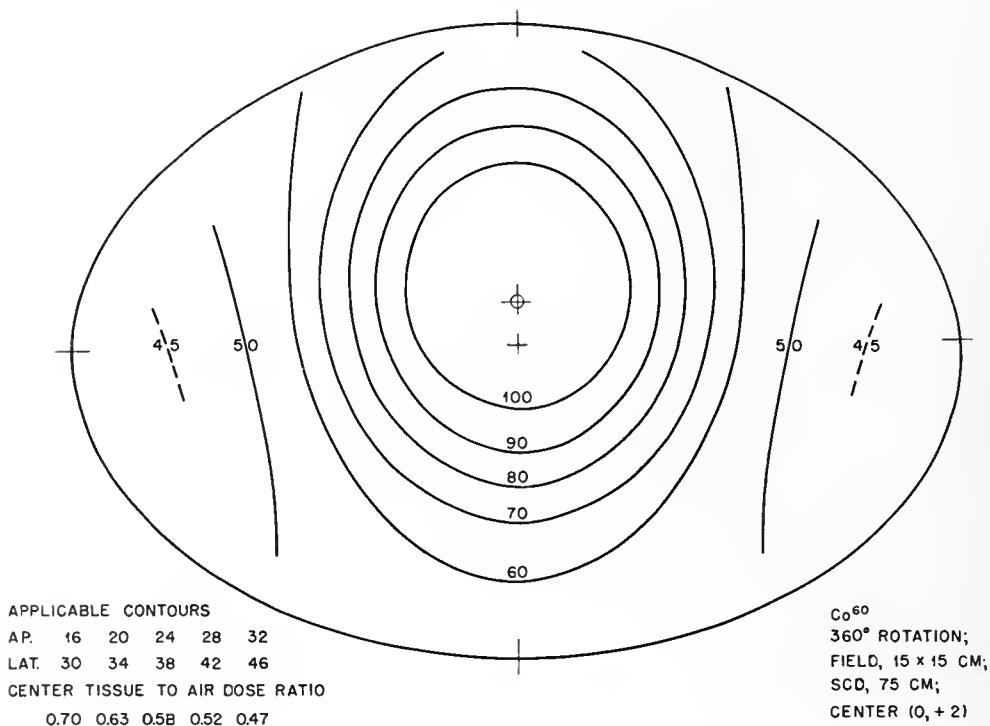

Fig. 7.

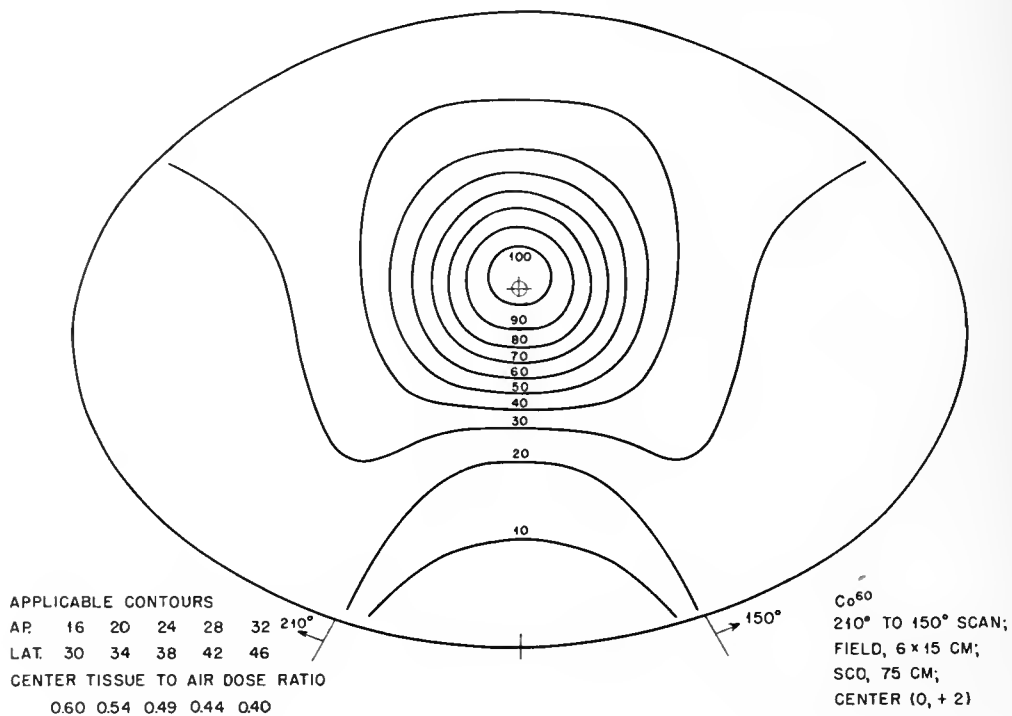

Fig. 8.

COBALT ISODOSE PATTERNS FOR MOVING BEAMS

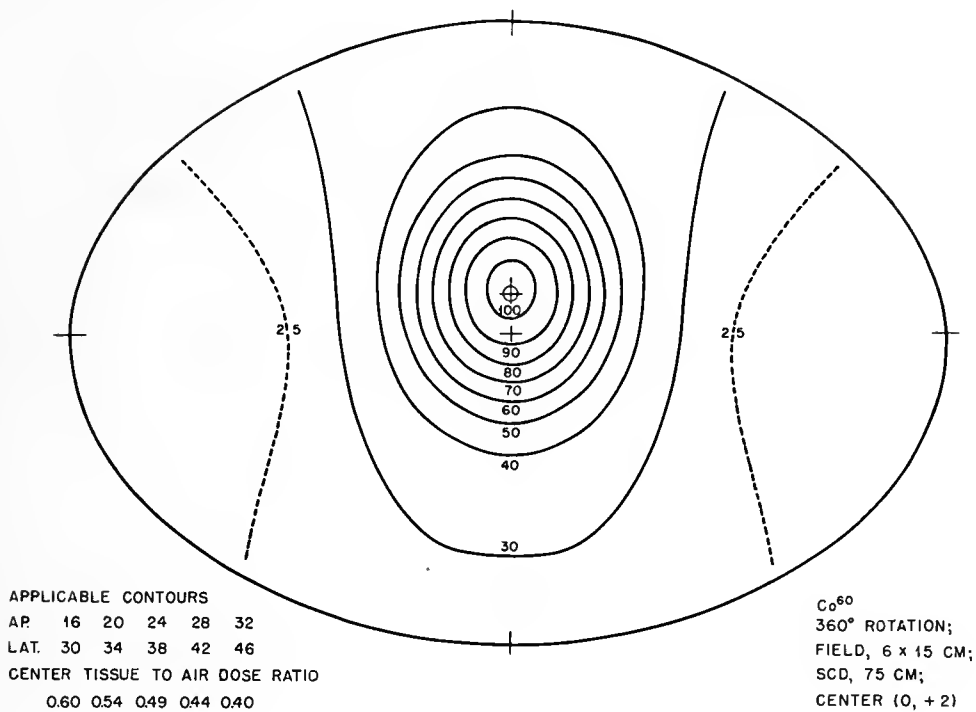

Fig. 9.

Supervoltage Rotation Dosage Patterns for Head and Neck Cancer

APPENDIX B

Milton Friedman and William H. Ellett*

Hospital for Joint Diseases
New York, New York

The dose distribution from supervoltage rotation irradiation has been discussed in a general manner. For each case the cross-section dosage-distribution pattern must be visualized. To aid in this, it becomes necessary to construct a comprehensive atlas of dosage patterns from which the appropriate one can be selected.

An atlas of this type was to be included in this volume. While the available data were being assembled, it became apparent that a set of 150 dosage patterns had not covered all important anatomical sites. It was therefore decided to amplify the data and to publish them in a separate volume rather than to present an incomplete appendix.

A few examples of the type of information obtainable from the contemplated atlas follow.

Example 1. In irradiation of a tumor near the surface, such as cancer of the parotid gland, middle ear, or tonsil, the position and shape of the high dosage volume (90 per cent isosurface) can be altered by changing the depth of the axis of rotation. For example, with 180-deg rotation the axis of rotation (indicated by a cross) may be placed on the skin (Fig. 1) or at a depth of 1 cm (Fig. 2). The dosage distribution is similar for both techniques. However, when the axis is placed 3 cm below the skin, the high dosage volume becomes larger, rounder, and com-

pletely immersed instead of partially immersed (Fig. 3).

Example 2. It is of interest to compare 180-deg rotation with 360-deg rotation, i.e., Fig. 3 as compared with Fig. 4. In this example the change in the amount of rotation increases the dose to the normal tissues, particularly the eye, without increasing the efficiency of the irradiation of the tumor volume.

Example 3. A useful technique is to irradiate the primary tumor and metastatic nodes "in continuity" (see Fig. 26a, Chap. 31). The geometric relation between the primary tumor and the lymph-node area varies considerably among individuals, depending on the size and shape of the head and neck. Figures 5a and b and 6a and b are the cross sections of two patients at the level of the primary tumor and neck nodes. In both cases, 360-deg rotation is used. The high dosage volume can be fitted to the area by varying the width of the beam and the depth of the axis of rotation. Figures 5a and b illustrate the dosage pattern for a small carcinoma of the tonsil with a single carotid node. Figures 6a and b illustrate the dosage pattern for an extensive carcinoma of the parotid gland with widespread cervical metastasis. The maximum dose to the primary tumor is called the 100 per cent dose. Note, in Fig. 6b, that a slightly higher dose (105 per cent) is delivered to the neck-node region because of the smaller cross-sectional area.

* Prepared with the assistance of Morris Hodara and Gerald J. Hine.

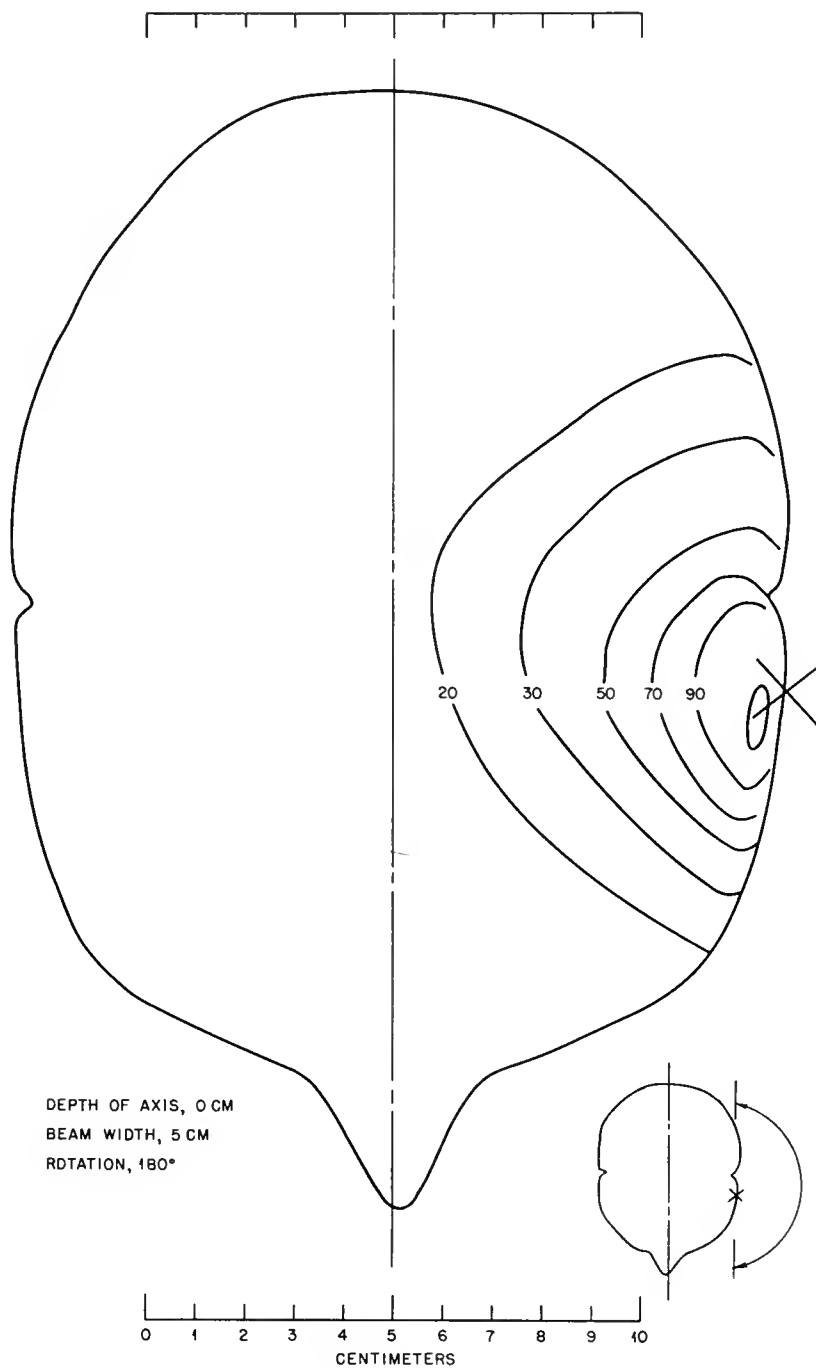

Fig. 1.

ISODOSE CURVES

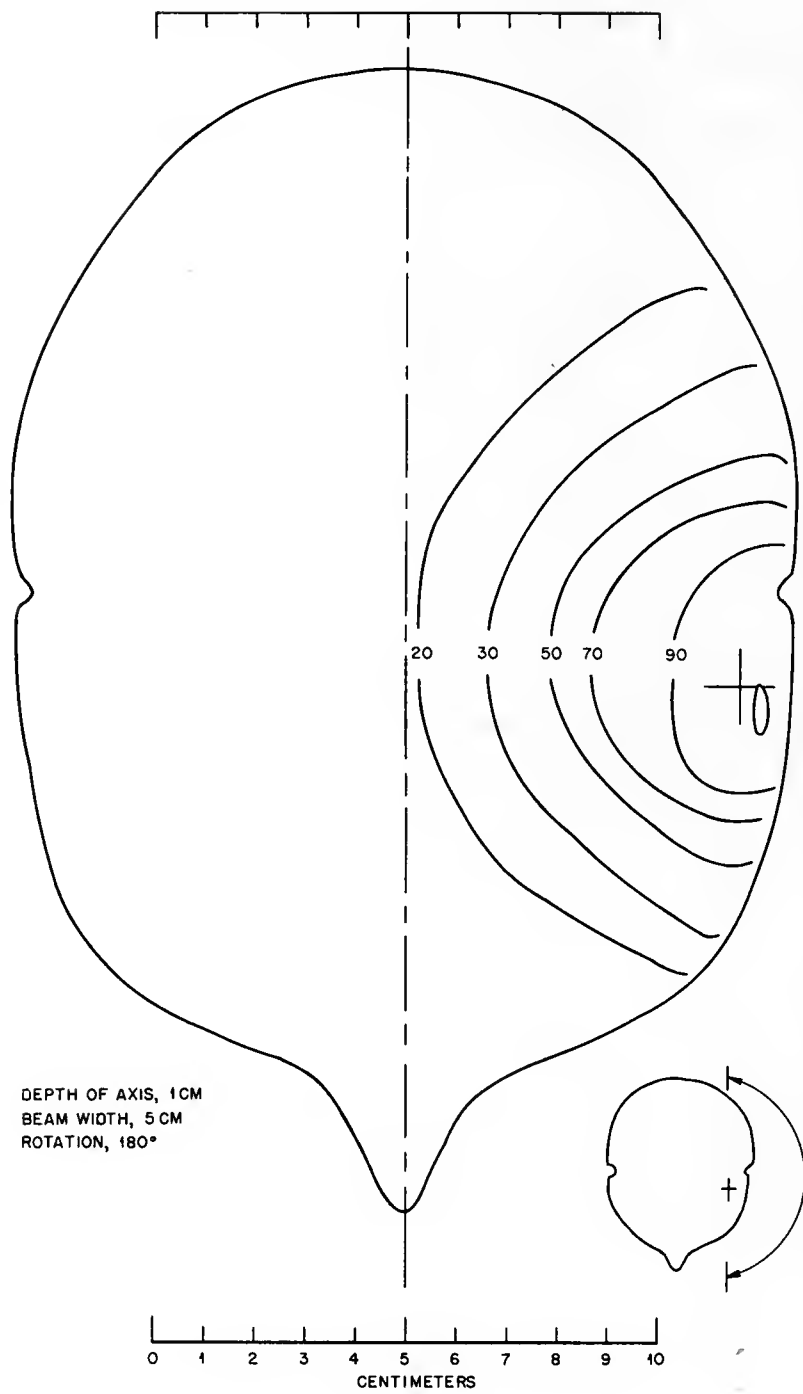

Fig. 2.

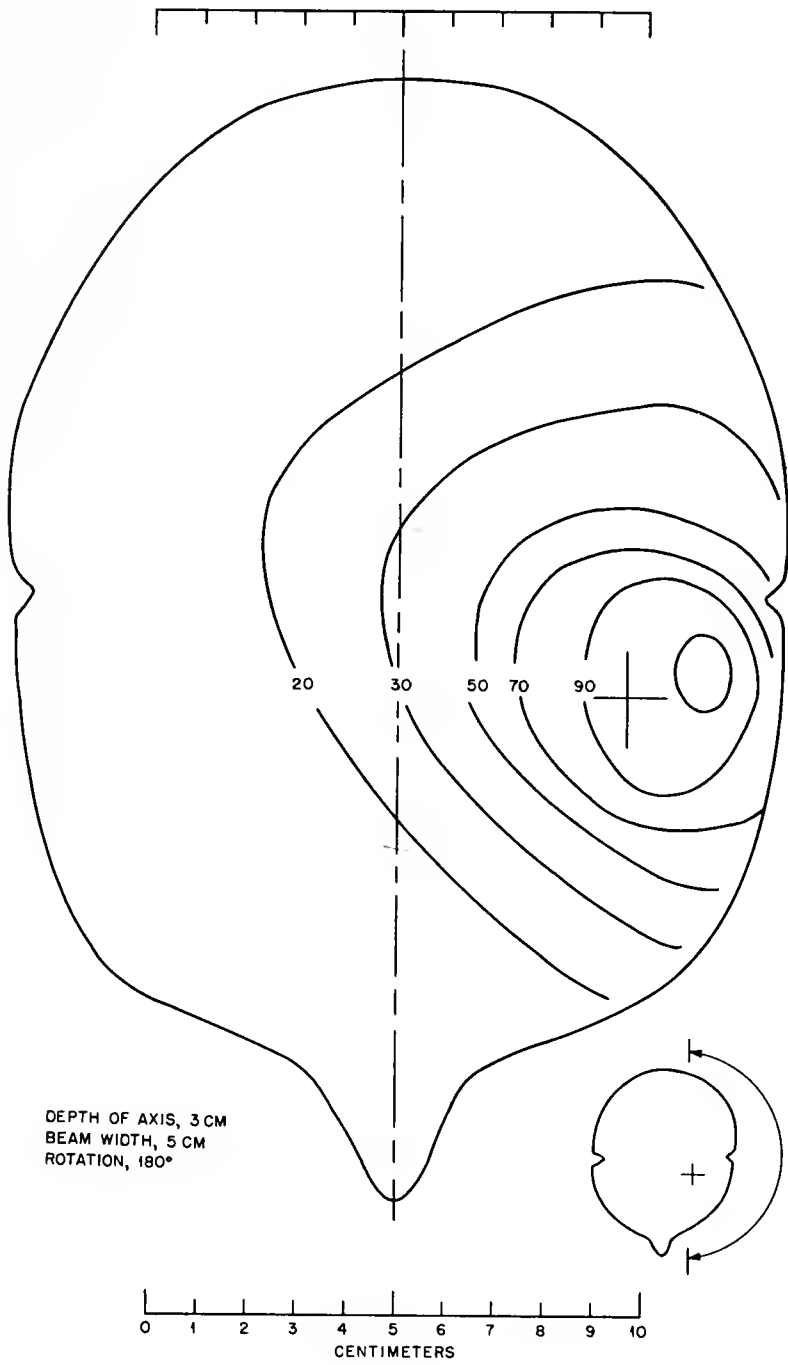

Fig. 3.

ISODOSE CURVES

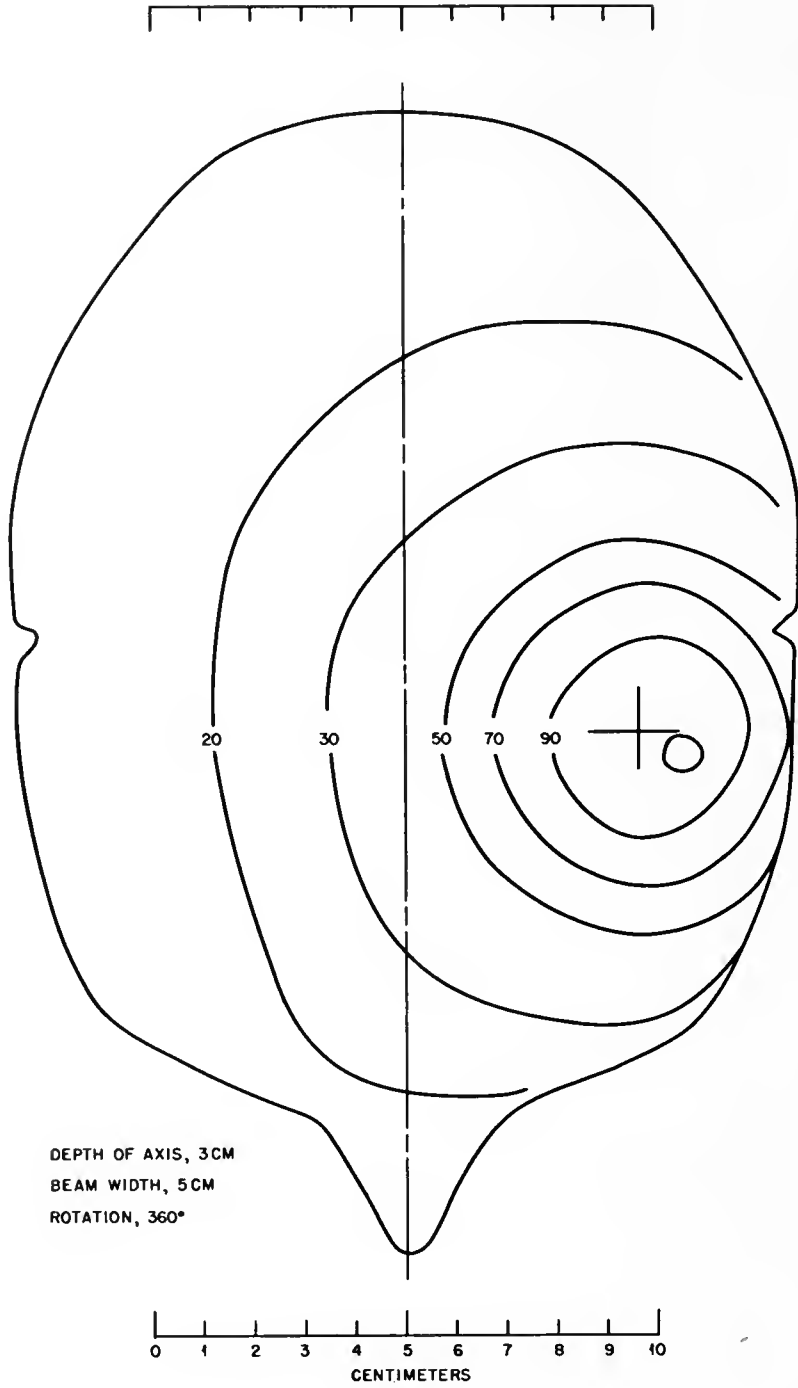

Fig. 4.

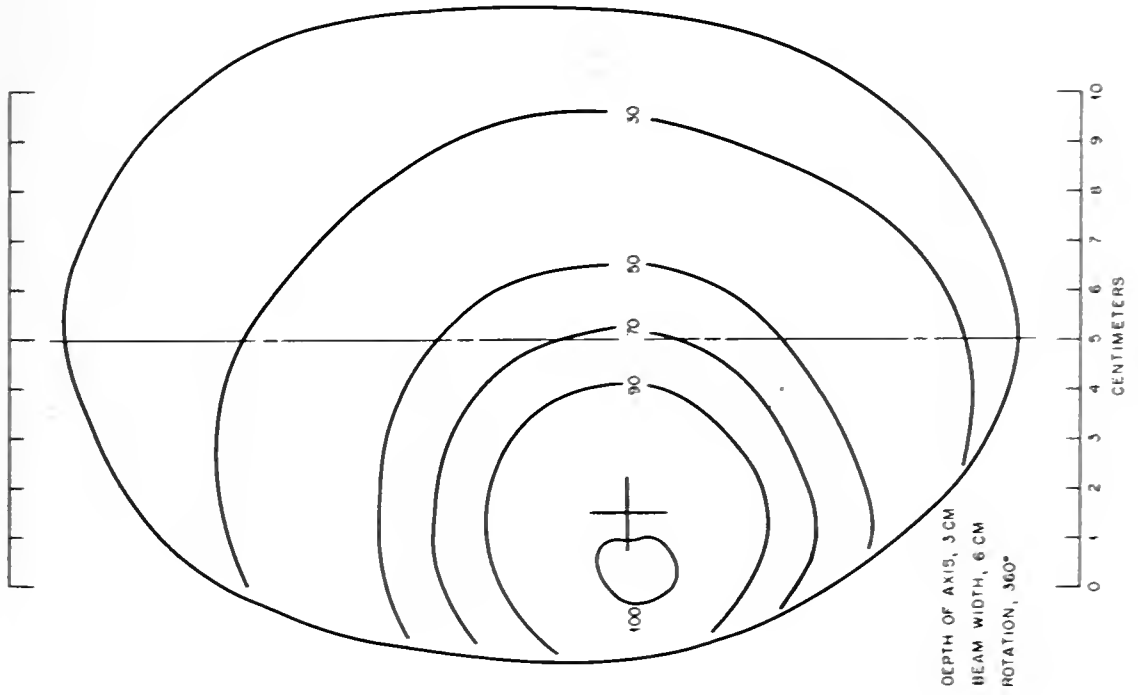

Fig. 5a.

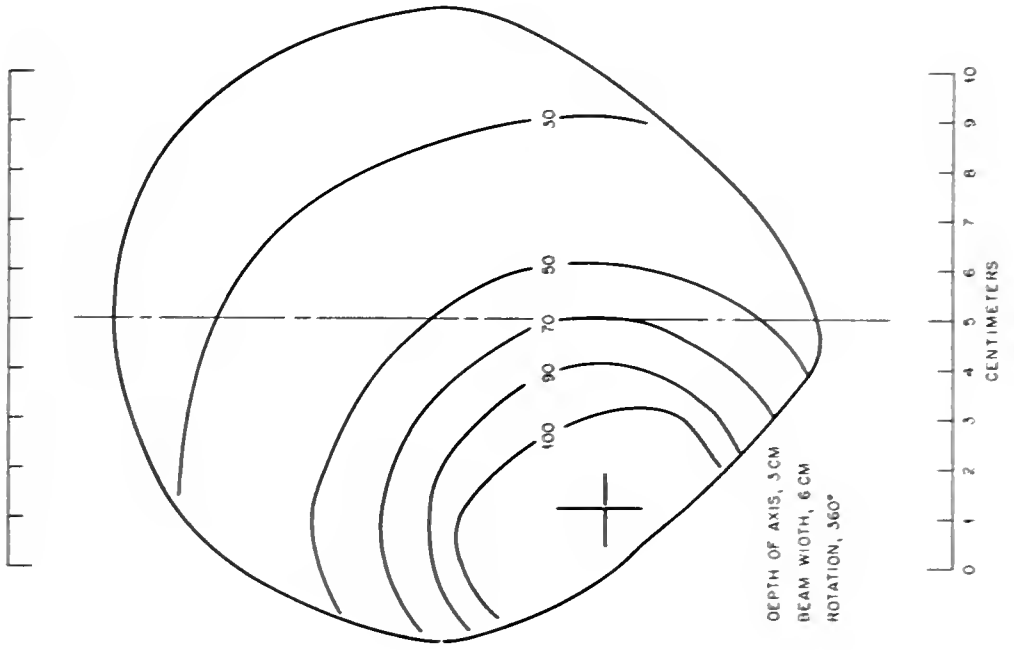
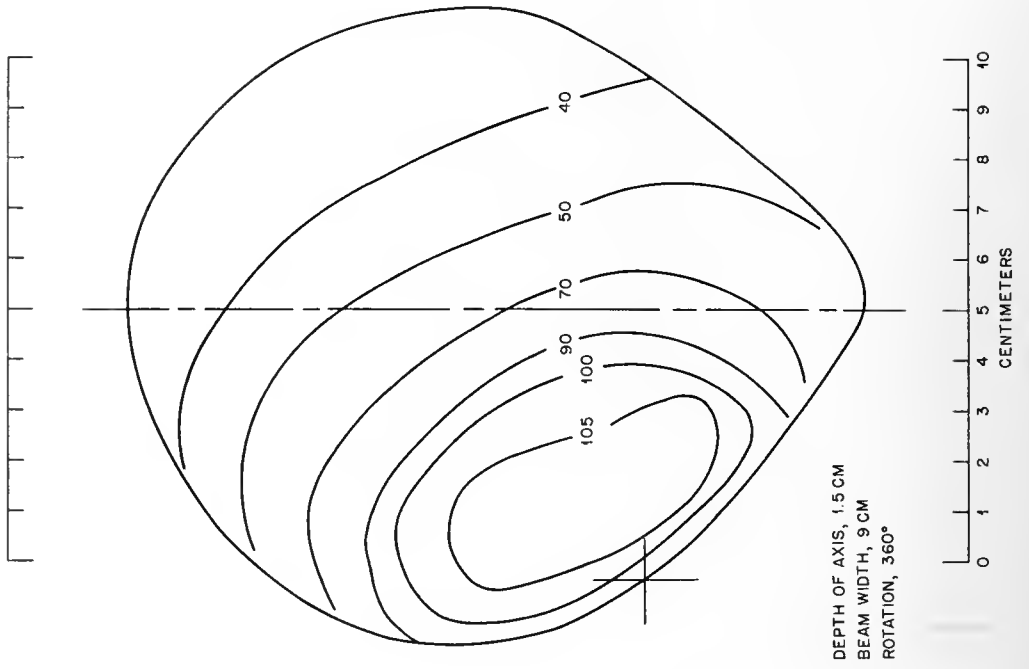
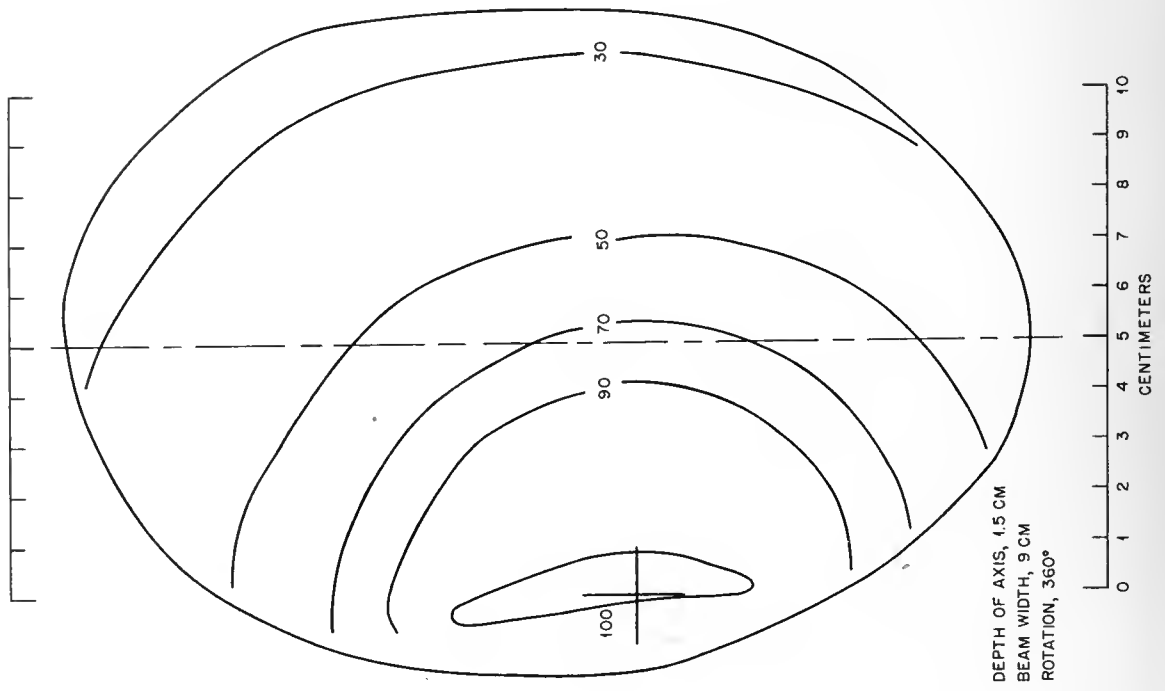

Fig. 5b.

ISODOSE CURVES



The Practicality of Cesium as a Teletherapy Source

APPENDIX C

Donald B. Darling

Oak Ridge Institute of Nuclear Studies*
Oak Ridge, Tennessee

Introduction

Since the advent of Co^{60} teletherapy machines, it has been obvious that such units have many advantages over conventional therapy machines. This has been not only in the high depth dose attainable, the skin-sparing effects, and the better tolerance of the patient to tumorocidal doses but also in the low cost of maintenance and infrequency of breakdowns in comparison to X-ray machines.

One disadvantage of Co^{60} soon became apparent to those using this modality: the short half life of 5.3 years, necessitating periodic recalibration of the unit's output and requiring replacement of the source after 5 to 10 years, depending on the strength of the original source and the practical output required of the individual unit. This feature of Co^{60} led Marshall Brucer and the ORINS to investigate other isotopes as possible substitutes for cobalt.

When all factors such as long half life, desirable gamma radiation, availability, cost, and ease of production were assessed, the most reasonable choice was Cs^{137} . The half life of 30 ± 3 years, gamma emission of 0.660 Mev (equivalent to a 1-Mv X-ray machine), and constant production in the reactor as a fission product left the main obstacle to the use of cesium the development of satisfactory methods for separating it from other fission products and for fashioning it into sources of appropriate size and shape. (This latter problem is not met with in cobalt since the machining is done on the nonradiative metal before placing it into the reactor to become activated.) The production obstacles have largely been overcome, and a number of cesium sources have been prepared for use in industrial radiography.

Experience with Cs^{137} in Teletherapy

As a result of the favorable characteristics found by physical measurements on a 2-curie Cs^{137} source, a

*Present address: Children's Hospital of Pittsburgh, 125 De Soto Street, Pittsburgh 13, Pa.

unique teletherapy machine was constructed, and a 1540-curie Cs^{137} source was installed at ORINS in 1955. After carrying out numerous physical measurements, Dr. Francisco Comas, in 1956, used the unit in treating several patients on an experimental basis. The results of these cases have been reported in a previous publication.¹

Several difficulties became evident in working with this unit. The rather low specific activity resulted in an output of only about 15 r/min as measured in air at 60 cm distance, and the large size of the source (3.18 cm in diameter) resulted in a definite penumbra problem. The latter became more serious as the field size was decreased until in very small fields the area covered by the penumbra approached the size covered by the visual field (Fig. 1). This effect was clearly seen on the isodose distribution plot of Dr. Comas's case of pituitary adenoma in which rotational therapy was used. The percentage of the central axis dose that reached the orbits was undesirably high because of the large penumbral contribution in the small field size used.

Subsequent Investigation and Experimentation

Several possible solutions to these problems were raised in our minds. The low output could be corrected by increasing the strength of the source. Since it would be undesirable to increase the diameter of the source much beyond the present size, the increase in strength must be obtained by increasing the thickness. The factor of self-absorption, however, limits the increase in output with increase in source thickness, with the result that it is impractical to have a source of thickness greater than 10 cm.

On the basis of the work of Brucer and associates² on the 2-curie source, the optimal source size would seem to be a diameter of 3.5 cm and a thickness of 10 cm. This would require a 7405-curie source and would give an output as measured in air of 32 r/min

at 70 cm and 60.6 r/min at 50 cm. This is a practical output for radiotherapy and compares favorably with conventional X-ray machines.

The penumbra problem appeared to be best approached by increasing the source-to-skin distance (SSD) while maintaining the collimator-to-skin distance constant. To test the validity of this approach, a number of isodose curves were plotted in a large water phantom. Source-to-skin distances of 50 to 70 cm and source-to-collimator distances of 31.3 to 60 cm were used in the measurements, which were made with an automatic isodose plotter constructed by the electronics shop of the ORINS Technical Services Department. The collimator aperture was adjusted to give a circular field of 10 cm diameter at 10 cm depth in the phantom for each isodose plot.

Results

The set of curves shown in Figs. 2 to 10 are isodose curves made by the Cs¹³⁷ automatic plotter for various SSD's, source-to-collimator distances, and collimator-to-skin distances. Figures 3, 6, and 10 show the effect of increasing the SSD from 50 to 70 cm while keeping the collimator-to-skin distance at 10 cm. If you consider the 90 to 25 per cent isodose lines as the significant penumbra, you can see that there is a definite narrowing of the penumbra zone as you increase the source-to-collimator distance.

The importance of maintaining the collimator-to-skin distance at the closest practical distance is graphically demonstrated by Figs. 7 to 10, in which the collimator-to-skin distance was varied from 10 cm to 38.7 cm, with the SSD constant at 70 cm. At 38.7 cm, the significant penumbra approximates the visual field. Here is a situation in which the ratio of the integral dose to the tumor dose is most unfavorable and in which the adjacent structures may receive an excessive amount of radiation.

It is apparent from this last set of curves that the minimal penumbra would be attained by bringing the collimator into direct contact with the skin. This is impossible in rotational therapy, and it is undesirable in stationary fields because of the electron build-up secondary to the interaction of the gamma radiation with the collimator. The use of cones of intermediate Z number will minimize this latter effect, but an absorbing layer of 10 cm of air is still advisable to filter out the emission from the cone. Such a collimator-to-skin distance should be practical in treatment with stationary fields, but greater distances will be necessary in rotational therapy, depending on the portion of the body being treated and the relation of the tumor to the mid-axis of the body.

It would be desirable to repeat these curves using a small field size at a tumor depth of 5 cm and of 1 cm. Theoretically the penumbra would still be a problem in the very small fields, even with the longer source-to-collimator distances; therefore tumors of the orbits, sinuses, and pituitary gland would be best treated by multiple stationary fields.

Conclusion

These studies suggest that Cs¹³⁷ used in sufficient strength and under proper geometrical conditions would prove to be a practical, economical, and reliable radiation source for clinical radiotherapy.

References

1. F. Comas and M. Brucer, First Impressions of Therapy with Cesium 137, *Radiology*, 69: 231-235 (August 1957).
2. M. Brucer, Special Report of the Medical Division on Teletherapy Design Problems. I. Cs¹³⁷, ORINS Cs¹³⁷ Meeting, May 15, 1951; Report TID-5086; 1st Rev., May 15, 1952; 2d Rev., May 15, 1955.

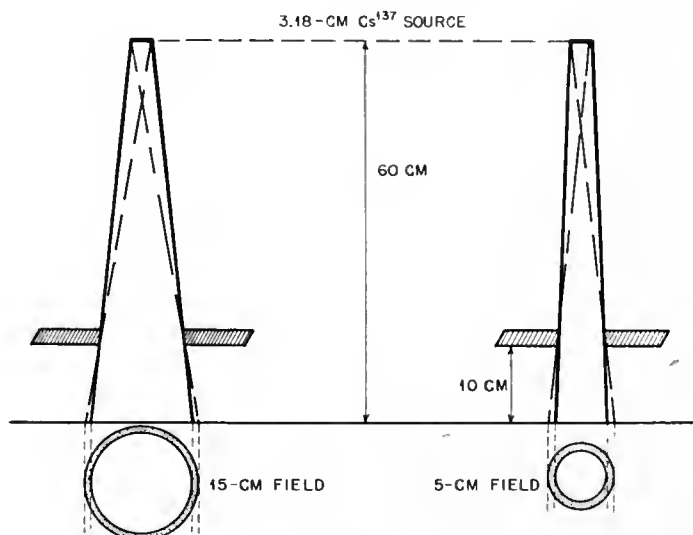

Fig. 1 — Increase in the area of the penumbra relative to the visual area as the field size is decreased.

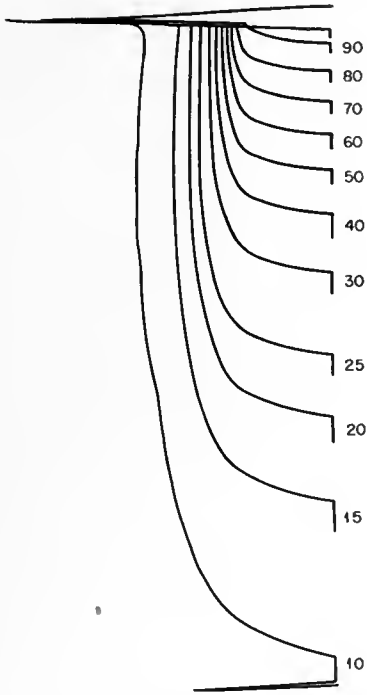

Fig. 2—Source-to-skin distance, 50 cm; source-to-collimator distance, 31.3 cm; collimator-to-skin distance, 18.7 cm; field, 10 cm diameter at 60 cm; aperture, 6.7 cm.

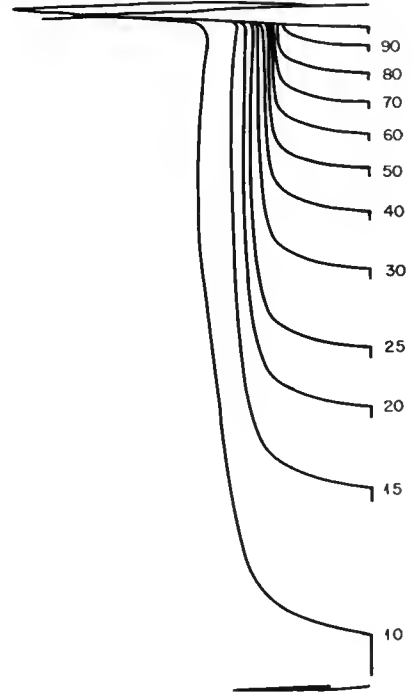

Fig. 3—Source-to-skin distance, 50 cm; source-to-collimator distance, 40 cm; collimator-to-skin distance, 10 cm; field, 10 cm diameter at 60 cm; aperture, 7.7 cm.

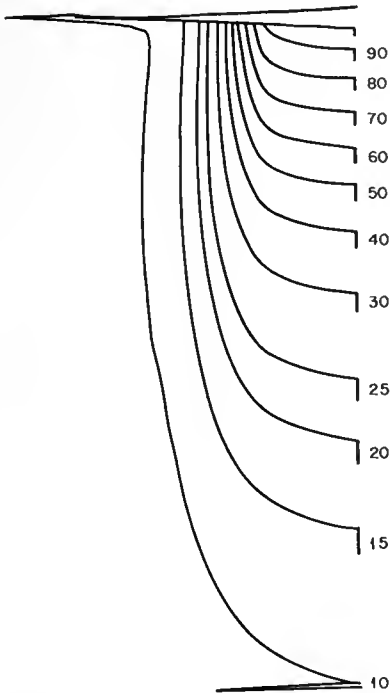

Fig. 4—Source-to-skin distance, 60 cm; source-to-collimator distance, 31.3 cm; collimator-to-skin distance, 28.7 cm; field, 10 cm diameter at 70 cm; aperture, 6.2 cm.

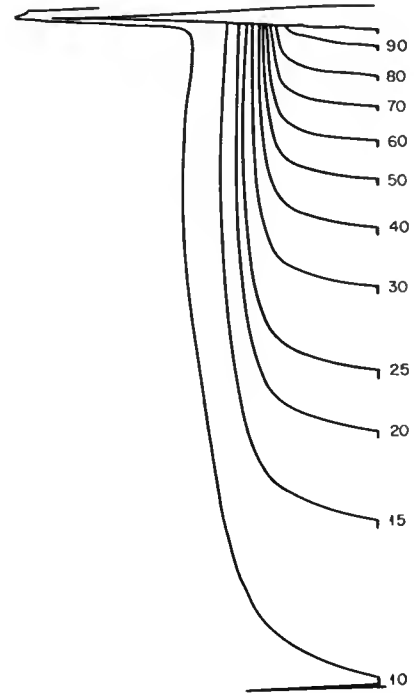

Fig. 5—Source-to-skin distance, 60 cm; source-to-collimator distance, 40 cm; collimator-to-skin distance, 20 cm; field, 10 cm diameter at 70 cm; aperture, 7.1 cm.

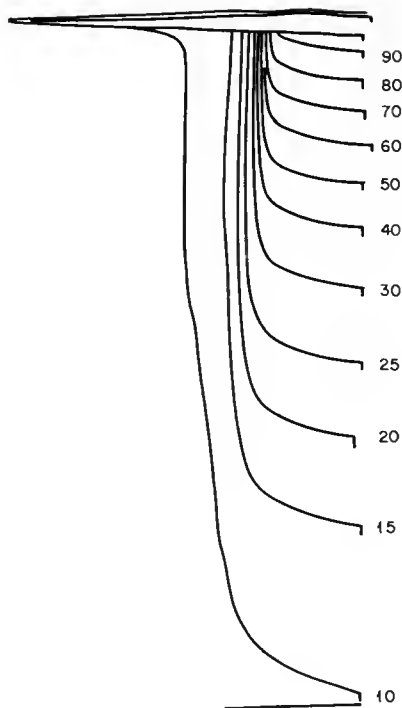

Fig. 6—Source-to-skin distance, 60 cm; source-to-collimator distance, 50 cm; collimator-to-skin distance, 10 cm; field, 10 cm diameter at 70 cm; aperture, 8.2 cm.

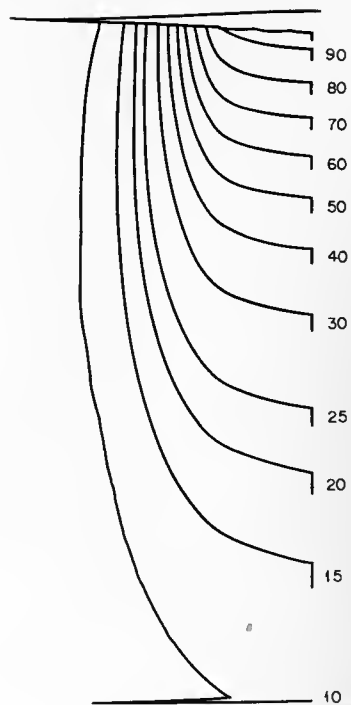

Fig. 7—Source-to-skin distance, 70 cm; source-to-collimator distance, 31.3 cm; collimator-to-skin distance, 38.7 cm; field, 10 cm diameter at 70 cm; aperture, 5.8 cm.

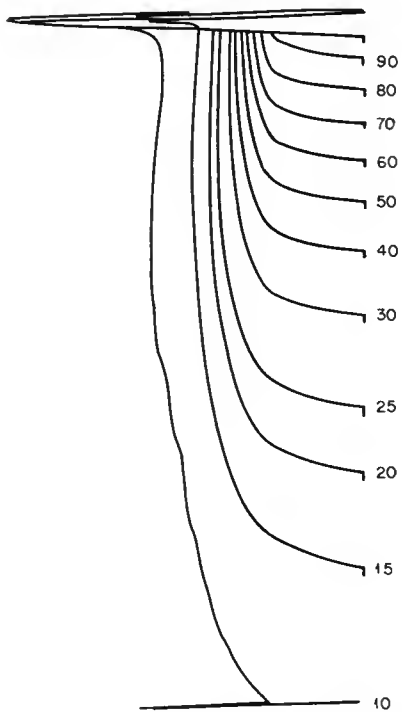

Fig. 8—Source-to-skin distance, 70 cm; source-to-collimator distance, 40 cm; collimator-to-skin distance, 30 cm; field, 10 cm diameter at 70 cm; aperture, 6.6 cm.

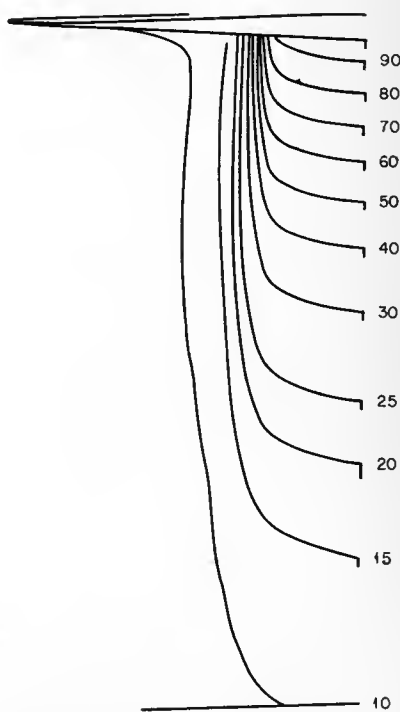

Fig. 9—Source-to-skin distance, 70 cm; source-to-collimator distance, 50 cm; collimator-to-skin distance, 20 cm; field, 10 cm diameter at 70 cm; aperture, 7.4 cm.

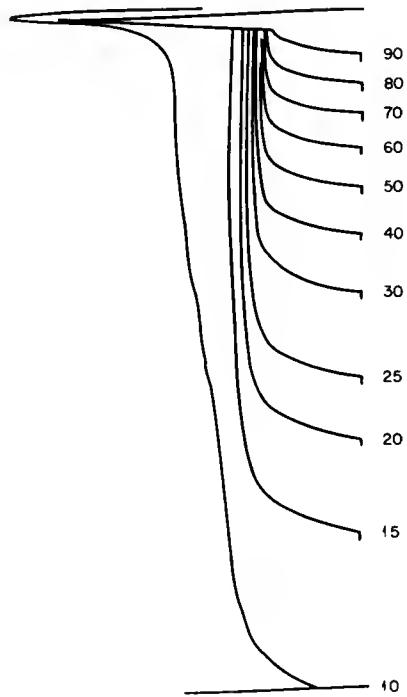
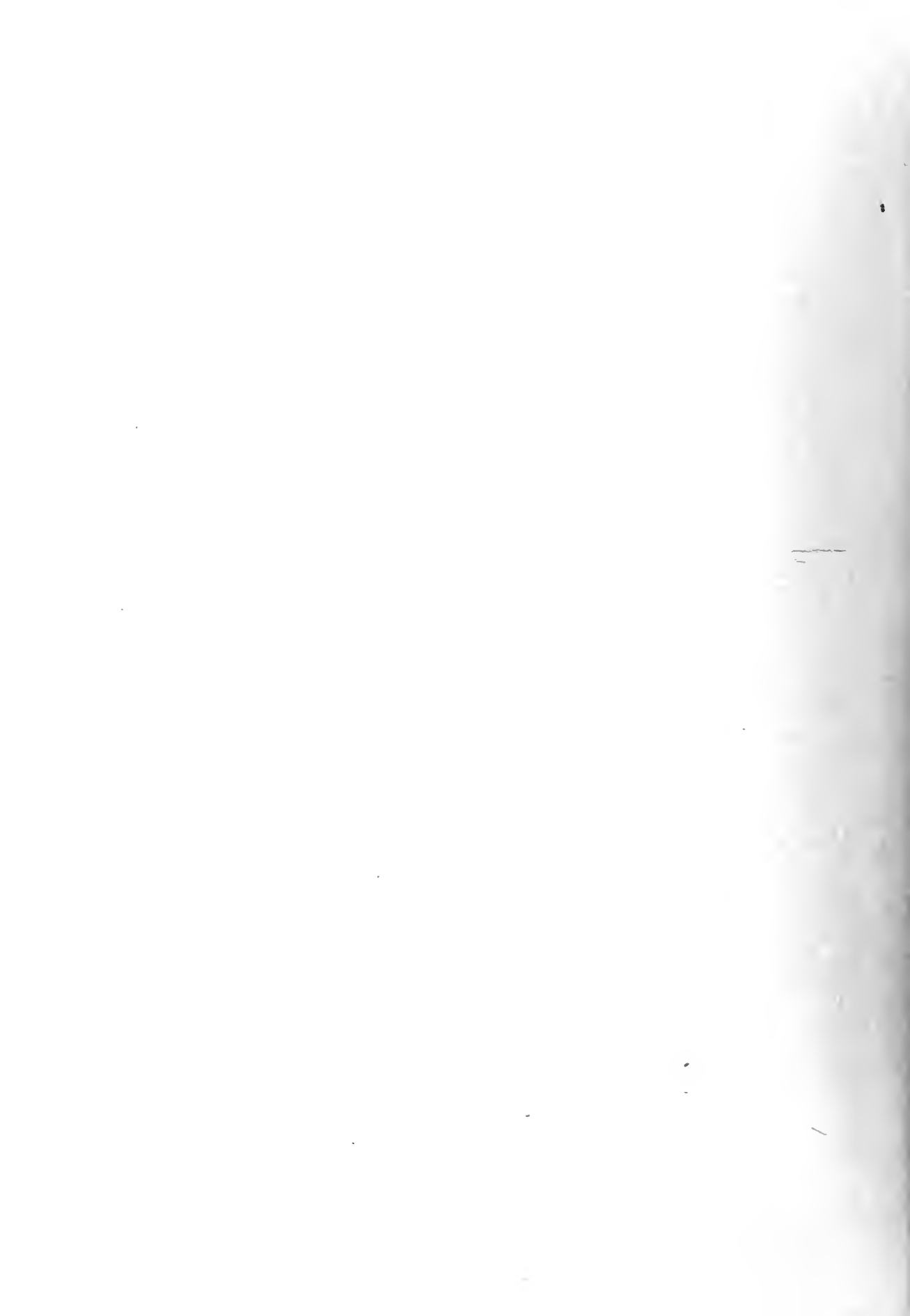

Fig. 10—Source-to-skin distance, 70 cm; source-to-collimator distance, 60 cm; collimator-to-skin distance, 10 cm; field, 10 cm diameter at 70 cm; aperture, 8.3 cm.



BIBLIOGRAPHY

The editors decided that the quoted bibliographic references should reflect the sources of information, aside from personal opinion, of the participants. Rather than to present an all-encompassing list of references, the editors preferred to construct a relatively smaller list of the more commonly used books and articles. The purpose of this bibliography is to simplify the task of the student who is starting his career as a radiotherapist. Consequently, each participant was asked to furnish a list of the 10 (more or less) references he considered most useful to the student of radiotherapy who has special interest in supervoltage and gamma-beam teletherapy.

In response to this request, a list of about 110 articles and about 50 books was submitted. (Special symposia and supplements to journals are included as "books." Special chapters in books are included as "articles.") Many excellent publications were mentioned frequently. For each category, the editors decided that it might be helpful to group (1) the two publications mentioned most frequently, (2) publications suggested several times, and (3) publications that were mentioned less frequently but nevertheless were considered useful. Several frequently mentioned articles were eliminated because their essence is contained in more recent publications by the same authors.

Books: Clinical

F. Buschke, S. T. Cantril, and H. M. Parker, "Supervoltage Roentgentherapy," Charles C Thomas, Publisher, Springfield, Ill., 1950.

R. F. Phillips and G. S. Innes, "Supervoltage X-ray Therapy: A Report for the Years 1937-1942 on the Mozelle Sassoon Supervoltage X-ray Therapy Department, St. Bartholomew's Hospital," H. K. Lewis, London, 1944, and Charles C Thomas, Publisher, Springfield, Ill., 1945.

E. R. Carling et al., editors, "British Practice in Radiotherapy," Butterworth & Co. (Publishers), Ltd., London, 1955.

R. Paterson, "Treatment of Malignant Disease by Radium and X-rays, Being a Practice of Radiotherapy," The Williams & Wilkins Co., Baltimore, Md., 1948, and Edward Arnold & Co., London, 1951.

L. V. Ackerman and J. A. del Regato, "Cancer Diagnosis, Treatment and Prognosis," 2d ed., C. V. Mosby Co., St. Louis, Mo.

S. Cade, "Malignant Disease and Its Treatment by Radium," The Williams & Wilkins Co., Baltimore, Md., 1952.

S. Cantril, "Radiation Therapy in the Management of Cancer of the Uterine Cervix," Charles C Thomas, Publisher, Springfield, Ill., 1950.

J. W. J. Carpender et al., "Supervoltage. Should We Junk 250 Kvp? A Symposium, Radiology, 67: 481-515 (1956).

C. D. Haagensen, "Diseases of the Breast," W. B. Saunders Co., Philadelphia, Pa., 1956.

G. W. Holmes and M. D. Schulz, "Therapeutic Radiology," Lea & Febiger, Philadelphia, Pa., 1950.

E. F. Lewison, "Breast Cancer and Its Diagnosis and Treatment," The Williams & Wilkins Co., Baltimore, Md., 1955.

U. V. Portmann, editor, "Clinical Therapeutic Radiology," Thomas Nelson & Sons, New York, 1950.

Radioisotopes in Medicine, a course given by the Oak Ridge Institute of Nuclear Studies, September 1953, edited by Gould A. Andrews, Marshall Brucer, and Elizabeth B. Anderson, Oak Ridge Institute of Nuclear Studies, Oak Ridge, Tenn., 1955, Report ORO-125. For sale by the Superintendent of Documents, U. S. Government Printing Office, Washington 25, D. C.; \$5.50.

D. W. Smithers, "The X-ray Treatment of Accessible Cancer," The Williams & Wilkins Co., Baltimore, Md., 1946.

D. W. Smithers et al., "Cancer of the Breast, a review from the Royal Cancer Hospital, London, honorary editor, L. G. Williams, British Institute of Radiology, London, 1952. (Brit. J. Radiol. Supplement No. 4).

- K. W. Stenstrom, "Manual of Radiation Therapy," Charles C Thomas, Publisher, Springfield, Ill., 1957.
- Symposium, Megavoltage Therapy, *Brit. J. Radiol.*, 29: 177-204 (1956).
- C. W. Wilson, "Radium Therapy, Its Physical Aspects and Extensions with Radioactive Isotopes," 2d ed., Baillière, Tindall & Cox, London, 1956.
- C. A. P. Wood and J. W. Boag, "Researches on Radiotherapy of Oral Cancer," Her Majesty's Stationery Office, London, 1950. [Medical Research Council (Great Britain), Special Report Series, No. 267.]

Books: Physical and Biological

- O. Glasser, E. H. Quimby, L. S. Taylor, and J. L. Weatherwax, "Physical Foundations of Radiology," 2d ed., Paul B. Hoeber, Inc., New York, 1952.
- H. E. Johns, "The Physics of Radiation Therapy," Charles C Thomas, Publisher, Springfield, Ill., 1953.
-
- G. J. Hine and G. L. Brownell, editors, "Radiation Dosimetry," Academic Press, Inc., New York, 1956.
- J. S. Laughlin, "Physical Aspects of Betatron Therapy," Charles C Thomas, Publisher, Springfield, Ill., 1954.
- W. V. Mayneord, "Some Applications of Nuclear Physics to Medicine," honorary editor, C. W. Wilson, British Institute of Radiology, London, 1950 (*Brit. J. Radiol. Supplement No. 2*).
-
- M. Brucer, Special Report of the Medical Division on Teletherapy Design Problems. I. Cs^{137} , Report TID-5086, 2d rev., May 15, 1955. Available from the Office of Technical Services, Department of Commerce, Washington 25, D. C.; \$0.40.
- M. Brucer, H. D. Kerman, and J. E. Richardson, Teletherapy Design Problems. II. Cobalt 60 Teletherapy Unit, Report ORO-109, 1953. For sale by the Superintendent of Documents, U. S. Government Printing Office, Washington 25, D. C.; \$0.35.
- M. Brucer et al., Teletherapy Design Problems (III) and supplement: Proceedings of the Third Industrial Conference on Teletherapy, Reports ORO-127 and ORO-127 (Suppl.), 1954. For sale by the Superintendent of Documents, U. S. Government Printing Office, Washington 25, D. C.; \$0.50 and \$0.35.
- M. Brucer, Teletherapy Design Problems. IV. Isodose Charts for the Co^{60} Hectocurie Teletherapy Machine, Report ORINS-10, Mar. 15, 1955. Available from the Office of Technical Services, Department of Commerce, Washington 25, D. C.; \$0.75.
- Central Axis Depth Dose Data for X Radiations of Half Value Layers from 0.01 Mm Al to 15.0 Mm Cu, Cobalt 60 Radiation, H. V. L. 11 Mm Pb, and Betatron Radiation, 22 Mev, a survey made by the Scientific Subcommittee of the Hospital Physicists' Association, edited by C. B. Allaopp, British Institute of Radiology, London, 1953. (*Brit. J. Radiol. Supplement No. 5*).
- Conference on Certain Aspects of the Action of Radiation on Living Cells, London, 1946, report of London Conference held May 12-14, 1956, edited by F. G. Spear, British Institute of Radiology, London, 1947 (*Brit. J. Radiol. Supplement No. 1*).
- W. R. Dixon, C. Garrett, and A. Morrison, Cobalt 60 Teletherapy Unit: Output, Depth Dose, and Isodose Distributions, National Research Council of Canada, Report NRC-2667, February 1952.

- G. W. Grodstein, X-ray Attenuation Coefficients from 10 KeV to 100 Mev, U. S. National Bureau of Standards Circular No. 583, National Bureau of Standards, U. S. Department of Commerce, Washington, D. C.
- Handbooks, U. S. National Bureau of Standards. Available from the Superintendent of Documents, U. S. Government Printing Office, Washington 25, D. C.

No.	Title	Price
42	Safe Handling of Radioactive Isotopes	\$0.20
48	Control and Removal of Radioactive Contamination in Laboratories	0.15
50	X-ray Protection Design	0.20
51	Radiological Monitoring Methods and Instruments	0.20
52	Maximum Permissible Amounts of Radioisotopes in the Human Body and Maximum Permissible Concentrations in Air and Water	0.25
54	Protection Against Radiations from Radium, Cobalt 60, and Cesium 137	0.25
55	Protection Against Betatron-Synchrotron Radiations Up to 100 Million Electron Volta	0.25
57	Photographic Dosimetry of X and Gamma Rays	0.15
58	Radioactive Waste Disposal in the Ocean	0.20
59	Permissible Dose from External Sources of Ionizing Radiation	0.30
60	X-ray Protection	0.20
61	Regulation of Radiation Exposure by Legislative Means	0.25
62	Report of the International Commission on Radiological Units and Measurements (ICRU), 1956.	0.40
	A. Hollaender, editor, "Radiation Biology," Vol. 1, Part 1, McGraw-Hill Book Company, Inc., New York, 1954.	
	A. Hollaender, editor, "Radiation Biology," Vol. 3, McGraw-Hill Book Company, Inc., New York, 1956.	
	L. A. W. Kemp, "A Students' Radiological Mathematics," Blackwell Scientific Pub., Oxford, 1951.	
	D. E. Lea, "Actions of Radiations on Living Cells," 2d ed., The University Press, Cambridge, 1955.	
	R. H. Morgan and K. E. Corrigan, editors, "Handbook of Radiology," Year Book Publishers, Inc., Chicago, Ill., 1955.	
	J. J. Nickson, editor, "Symposium on Radiobiology, Oberlin College, 1950. The Basic Aspects of Radiation Effects on Living Systems," John Wiley & Sons, Inc., New York, 1952.	
	Oak Ridge National Laboratory Catalog and Price List of Radioisotopes Including Special Materials and Services, Oak Ridge National Laboratory, Oak Ridge, Tenn., 1947. Direct requests to: Isotopes Sales Department, Attention: J. H. Gillette, Union Carbide Nuclear Company, Oak Ridge National Laboratory, P. O. Box X, Oak Ridge, Tenn.	
	J. K. Robertson, "Radiology Physics: An Introductory Course for Radiologists, Radiographers and Medical Students," 3d ed., Macmillan & Co., Ltd., London, 1956.	
	"Recommendations of the International Commission on Radiological Protection," rev. Dec. 1, 1954, British Institute of Radiology, London, 1955 (<i>Brit. J. Radiol. Supplement No. 6</i>).	
	Standing Advisory Committee, Ministry of Health, Code of Practice for the Protection of Persons Exposed to Ionizing Radiations, Her Majesty's Stationery Office, London, 1957.	
	F. Wachamann and A. Dimotsis, "Graphs and Tables for Radiotherapy," S. Hirzel Verlag, Stuttgart, 1957.	

F. Wachsmann and G. Barth, "Die Bewegungsbestrahlung," G. Thleme, Stuttgart, 1953.

Articles: Clinical

C. C. Burkell, T. A. Watson, H. E. Johns, and R. J. Horsley, Skin Effects of Co⁶⁰ Telecurie Therapy, *Brit. J. Radiol.*, 27: 171-176 (1954).

M. Friedman, G. J. Hine, and J. Dresner, Principles of Supervoltage (2 Million Volts) Rotation Therapy; Illustrated by the Treatment of a Chordoma of the Vertebra, *Radiology*, 64: 1-16 (1955).

.

F. Baclesse, A Method of Preoperative Roentgentherapy by High Doses, Followed by Radical Operation for Carcinoma of the Breast, Showing Survivals Up to 10 Years, *J. Fac. Radiologists London*, 6: 145-163 (1955).

G. W. Blomfield, Clinical Evaluation of Results in Supervoltage X-ray Therapy, *J. Fac. Radiologists London*, 7: 260-277 (1956).

M. Friedman, Calculated Risks of Radiation Injury of Normal Tissue in the Treatment of Cancer of the Testis, in Proceedings of the Second National Cancer Conference, Cincinnati, Ohio, Mar. 3-5, 1952, Vol. 1, pp. 390-400, American Cancer Society, National Cancer Institute of the U. S. Public Health Service, and American Association for Cancer Research, American Cancer Society, New York, 1954.

W. S. Halsted, The Results of Operations for the Cure of Cancer of the Breast Performed at the Johns Hopkins Hospital from June 1889 to January 1894, *Ann. Surg.*, 20: 497-555 (1894).

H. F. Hare, S. W. Lippincott, Jr., D. Sawyer, J. G. Trump, E. W. Webster, K. A. Wright, W. W. Evans, and R. C. Granke, Physical and Clinical Aspects of Supervoltage Rotational Therapy, *Radiology*, 57: 157-167 (1951).

P. B. Kunkler, R. F. Farr, and R. W. Luxton, The Limit of Renal Tolerance to X-rays: An Investigation into Renal Damage Occurring Following the Treatment of Tumors of the Testis by Abdominal Baths, *Brit. J. Radiol.*, 25: 190-201 (1952).

M. Lenz, Radiocurability of Cancer, *Am. J. Roentgenol.*, 67: 428-442 (1952).

J. J. McDonald, C. D. Haagensen, and A. P. Stout, Metastasis from Mammary Carcinoma to Supraclavicular and Internal Mammary Lymph Nodes, *Surgery*, 34: 521-542 (1953).

R. McWhirter, Cancer of the Breast, *Am. J. Roentgenol.*, 62: 335-340 (1949).

J. Nielsen and H. Jensen, Sr., Some Experimental and Clinical Lights on the Rotation Therapy, Its Basis and Possibilities, *Acta Radiol.*, 23: 51-66 (1942).

S. M. Silverstone and N. Simon, The Advantages of Cobalt 60 in the Practice of Radiotherapy, *J. Mt. Sinai Hosp., N. Y.*, 24: 124-136 (1957).

D. W. Smithers, Radiotherapist and the Cancer Patient, *Brit. J. Radiol.*, 20: 261-268 (1947).

R. S. Stone, Radiation Therapy of Tumors with a Consideration of Possible Advantage of Supervoltage X Rays, *Minnesota Med.*, 21: 79-85 (1938).

.

H. I. Amory and I. B. Brick, Irradiation Damage of the Intestines Following 1,000 Kv Roentgen Therapy: Evaluation of Tolerance Dose, *Radiology*, 56: 49-57 (1951).

G. W. Blomfield, Clinical Results in 2 Million Volt X-ray Therapy, *Indian Journal of Radiology (Souvenir Number)*, 409-423 (1956).

C. C. Burkell and T. A. Watson, Some Observations on the Clinical Effects of Cobalt 60 Telecurie Therapy, *Am. J. Roentgenol.*, 76: 895-904 (1956).

S. M. Busby, The Cobalt Bomb in the Treatment of Bladder Tumours: A Preliminary Report, *Can. Med. Assoc. J.*, 73: 872-875 (1955).

F. Buschke, Clinical Application of Supervoltage Radiation, *Cancer Bulletin, Texas*, 8: 12-18 (1956).

S. T. Cantril, Two Cases Treated with 800 Kv and 400 Kv, Respectively, *Radiology*, 67: 481-484 (1956).

J. W. J. Carpender, Supervoltage Radiotherapy, editorial, *Radiology*, 67: 587-588 (1956).

V. P. Collins, Role of Supervoltage Radiation in Cancer Therapy, *Texas State J. Med.*, 53: 35-40 (1957).

G. H. Fletcher, A Clinical Program To Evaluate the Practical Significance of Higher Energy Levels than the 1-3 Mev, *Am. J. Roentgenol.*, 76: 866-894 (1956).

G. H. Fletcher, Present Status of Cobalt 60 Teletherapy in the Management of the Cancer Patient, *J. Am. Med. Assoc.*, 164: 244-248 (1957).

G. H. Fletcher, J. E. Richardson, E. B. Moore, J. M. Morgan, and A. Cole, Clinical Stationary Field Therapy with a Cobalt 60 Unit, Parts I and II, *Am. J. Roentgenol.*, 75: 91-128 (1956).

J. R. Freid, H. Goldberg, W. Tenzel, C. L. Okrainetz, and M. I. Aral, Cobalt 60 Beam Therapy: Three Years' Experience at Montefiore Hospital (New York), *Radiology*, 67: 200-209 (1956).

M. Friedman, The Superior Value of Supervoltage Irradiation in Special Situations: Carcinoma of the Mouth and Carcinoma of the Testis, *Radiology*, 67: 484-497 (1956).

M. Friedman, Supervoltage (1,000,000 Volt) Roentgen Therapy at Walter Reed General Hospital, *Surg. Clin. North Am.*, 24: 1424-1432 (1944).

R. J. Guttmann, The Treatment of Inoperable Carcinoma of the Breast with Conventional 250-kv Irradiation as Compared with 2-Mv Irradiation, *Radiology*, 67: 497-506 (1956).

H. F. Hare, J. G. Trump, and E. W. Webster, Rotational Scanning of Breast Malignancies with Supervoltage Radiation, *Am. J. Roentgenol.*, 68: 435-447 (1952).

H. Jensen, Sr., J. Nielsen, and V. Thyssen, Evaluation of Different Factors in Rotation Therapy, *Acta Radiol.*, 25: 95-104 (1944).

C. E. Johanson, G. Ostling, and R. V. Gasstrom, Treatment of Uterine Cancer with Radioactive Cobalt (Co⁶⁰), *Acta Radiol.*, 36: 324-328 (1951).

D. A. Layne, L. Valentine, W. V. Mayneord, W. McKissock, and D. W. Smithers, The Treatment of Cerebral Gliomas with 24 Million Volt X Rays, *Lancet*, 1: 516-519 (1953).

T. Leucutia, Comparative Value of Deep and Supervoltage Roentgen Therapy: Statistical Analysis of 5 Year Results in Selected Groups, *Am. J. Roentgenol.*, 58: 347-356 (1947).

T. Leucutia, Editorial—Supervoltage Radiation Therapy with Roentgen-ray and Gamma-ray Beams, *Am. J. Roentgenol.*, 73: 124-126 (1955).

T. Leucutia and K. E. Corrigan, Present Status of Roentgen Therapy with Voltages Above 200 Kv, *Am. J. Roentgenol.*, 31: 628-662 (1934).

S. S. Mitchell, C. L. Smith, D. J. Allen-Williams, and R. Braams, Experience with the 30-Mev Synchrotron as a Radiotherapeutic Instrument, *Acta Radiol.*, 40: 419-434, 463-478, 603-613 (1953).

R. Morrison, G. R. Newbery, and T. J. Deeley, Preliminary Report on the Clinical Use of the Medical Research Council 8-Mev Linear Accelerator, *Brit. J. Radiol.*, 29: 177-186 (1956).

W. T. Murphy, The Clinical and Physical Significance of Quality in Routine Teleirradiation Therapy, *N.Y. State J. Med.*, 42: 966-972 (1942).

- W. T. Murphy, Recent Trends in Therapeutic Radiology, N. Y. State J. Med., 55: 2149-2156 (1955).
- W. T. Murphy and M. C. Reinhard, Some Observations with 1,000-kv, 400-kv, and 200-kv X-ray Therapy, Radiology, 55: 477-493 (1950).
- J. Nielsen, Indications for Rotational Therapy, Acta Radiol., 116: 541-549 (1954).
- J. F. Nolan, J. A. Vidal, and J. H. Anson, Early Experiences in the Treatment of Carcinoma of Uterine Cervix with Cobalt 60 Teletherapy and Intracavitary Radium, Am. J. Obstet. Gynecol., 72: 780-803 (1956).
- J. A. del Regato, The Potentialities of Radiotherapy of Malignant Neoplasms, in Radioisotopes in Medicine, a course given by the Oak Ridge Institute of Nuclear Studies, September 1953, edited by Gould A. Andrews, Marshall Brucer, and Elizabeth B. Anderson, Oak Ridge Institute of Nuclear Studies, Oak Ridge, Tenn., Report ORO-125, 1955, pp. 643-649.
- M. D. Schulz, Supervoltage Roentgen Therapy in Cancer of the Mouth and Throat, Radiology, 55: 52-59 (1950).
- J. G. Trump, R. C. Granke, K. A. Wright, W. W. Evans, H. F. Hare, E. E. Ewert, and W. L. Conlon, Treatment of Tumors of the Pelvic Cavity with Supervoltage Radiation, Am. J. Roentgenol., 72: 284-292 (1954).
- J. G. Trump, K. A. Wright, W. W. Evans, J. H. Anson, H. F. Hare, J. L. Fromer, G. Jacque, K. W. Horne, High Energy Electrons for the Treatment of Extensive Superficial Malignant Lesions, Am. J. Roentgenol., 69: 623-629 (1953).
- M. Tubiana, J. Dutreix, B. Pierquin, and P. Jockey, Conditions pratiques d'utilisation medicale d'un betatron de 22 Mev, J. Radiol. et électrol., 36: 507-522 (1955).
- T. A. Watson, Comparison of Conventional and Supervoltage Radiation in Carcinoma of the Bladder, Radiology, 67: 506-509 (1956).
- T. A. Watson, The Clinical Possibilities of the Cobalt 60 Beam Unit, J. Can. Assoc. Radiologists, 3: 7-10 (1952).
- T. A. Watson, Supervoltage Roentgen Therapy in Cancer of the Lung, Am. J. Roentgenol., 75: 525-529 (1956).
- T. A. Watson and C. C. Burkell, The Betatron in Cancer Therapy, Parts I and II, J. Can. Assoc. Radiologists, 2: 60-64 (1951) and 3: 25-28 (1952).
- K. F. Orton, Rotation Therapy with a 2-Mev Van de Graaff Generator, Brit. J. Radiol., 29: 186-192 (1956).
- J. G. Trump, K. A. Wright, W. W. Evans, H. F. Hare, and S. W. Lippincott, Jr., Two Million Volt Roentgen Therapy Using Rotation, Am. J. Roentgenol., 66: 613-623 (1951).
- K. A. Wright, R. C. Granke, and J. G. Trump, Physical Aspects of Megavolt Electron Therapy, Radiology, 67: 553-561 (1956).
- C. B. Braestrup and R. T. Mooney, Cobalt 60 Protection Design, Radiology, 65: 884-891 (1955).
- F. Buschke, Fundamental Radiobiology, Cancer Bulletin (M. D. Anderson Hospital, Houston, Tex.), 8: 2-7 (1956).
- V. Castro, C. Sofier, and E. Quimby, Calculation of Dosage in Vertical Rotation Therapy Using Standard Isodose Charts, Am. J. Roentgenol., 73: 815-826 (1955).
- D. V. Cormack and H. E. Johns, Electron Energies and Ion Densities in Water Irradiated with 200-kev, 1-Mev and 25-Mev Radiation, Brit. J. Radiol., 25: 369-381 (1952).
- W. R. Dixon, C. Garrett, and A. Morrison, Room-protection Measurements for Cobalt 60 Teletherapy Units, Nucleonics, 10(3): 42-45 (1952).
- J. Dresner, Optimum Physical Factors for Rotation X-ray Therapy, Brit. J. Radiol., 27: 340-343 (1954).
- G. Failla, Protection Against High Energy Roentgen Rays, Caldwell Lecture 1945, Am. J. Roentgenol., 54: 553-582 (1945).
- G. H. Fletcher, P. Wootton, W. H. Storey, and R. J. Shalek, Physical Factors in the Use of Cobalt 60 in Interstitial and Intracavitary Therapy, Am. J. Roentgenol., 71: 1021-1037 (1954).
- D. Greene and F. W. Tranter, Dosage Data for 4,000,000-Volt X Rays, Brit. J. Radiol., 29: 193-196 (1956).
- C. Gregory, Dosage Distribution in Rotational Cobalt 60 Therapy, Brit. J. Radiol., 30: 538-543 (1957).
- J. L. Haybittle, The Effect of Source Size upon Integral Dose in Teletherapy Units, Acta. Radiol., 42: 65-74 (1954).
- J. L. Haybittle, Physical Requirements of Beam Defining Systems for Medium Distance Teletherapy Units, Acta. Radiol., 44: 505-520 (1955).
- E. Hayward, The Electron Spectra Produced by a Cobalt 60 Source in Water, Am. J. Roentgenol., 71: 333-336 (1954).
- C. L. Hsieh, The Stray Radiation Levels of a 45-Mev Travelling Wave Linear Electron Accelerator, Brit. J. Radiol., 29: 201-204 (1956).
- L. E. Jacobson and I. Knauer, Absorption in Different Tissues of Cobalt 60 Gamma Radiation and Roentgen Rays with Half Value Layers from 1 Mm Al to 5 Mm Cu, Radiology, 66: 70-83 (1956).
- L. Jacobson and I. Knauer, Stray Radiation Measurements Around a Cobalt 60 Beam Therapy Installation, Am. J. Roentgenol., 73: 272-280 (1955).
- W. A. Jennings and A. L. McCrea, Dose Distribution in Conical Rotation Therapy with 2-Mev Generator, Radiology, 68: 689-697 (1957).
- H. E. Johns, The Betatron in Cancer Therapy, Nucleonics, 4: 76-83 (1950).
- H. E. Johns, Physical Characteristics of the Radiation in Cobalt 60 Beam Therapy, J. Can. Assoc. Radiologists, 3: 2-6 (1952).
- H. E. Johns, X-rays and Teleisotope Gamma Rays, in "Radiation Dosimetry," edited by G. J. Hine and G. L. Brownell, pp. 531-596, Academic Press, Inc., New York, 1956.
- H. E. Johns, D. V. Cormack, G. F. Whitmore, and C. Garrett, Absolute Dose Measurement of Cobalt 60 Radiation, Radiology, 64: 113-114 (1955).
- H. E. Johns, E. K. Darby, T. A. Watson, and C. C. Burkell, Comparison of Dosage Distributions Obtainable with 400-

Articles: Physical and Biological

- C. B. Braestrup and R. T. Mooney, Physical Aspects of Rotating Telecobalt Equipment, Radiology, 64: 17-28 (1955).
- H. E. Johns, M. T. Morrison, and G. F. Whitmore, Dosage Calculations for Rotation Therapy, with Special Reference to Cobalt 60, Am. J. Roentgenol., 75: 1105-1116 (1956).
- S. O. Fedoruk, H. E. Johns, and T. A. Watson, Isodose Distributions for 1,100-Curie Cobalt 60 Unit, Radiology, 60: 348-354 (1953).
- M. Friedman, J. Dresner, and G. J. Hine, Supervoltage (2,000 Kilovolt Roentgen Rays) Irradiation with a Resonant Transformer Generator, Am. J. Roentgenol., 73: 410-424 (1955).
- S. Genna and J. S. Laughlin, Absolute Calibration of a Cobalt 60 Gamma-ray Beam, Radiology, 65: 394-405 (1955).
- D. E. A. Jones, C. Gregory, and I. Birchall, Dosage Distribution in Rotational Cobalt 60 Therapy, Brit. J. Radiol., 29: 196-201 (1956).
- L. D. MacDonald, R. L. Hayes, and M. Brucer, Integral Dose Measurements, Preliminary Report on a Cobalt 60 Teletherapy Beam, Radiology, 64: 115-116 (1955).

BIBLIOGRAPHY

- kvp X Rays and 22-Mev X Rays, *Brit. J. Radiol.*, 23: 290-299 (1950).
- H. E. Johns and J. A. Mackay, Collimating Device for Cobalt 60 Teletherapy Units, *J. Fac. Radiologists London*, 5: 239-247 (1954).
- H. E. Johns, M. T. Morrison, and T. A. Watson, Radiation Distribution from 1000-Curie Cobalt Unit Using Conventional and Rotation Techniques, *Acta. Radiol.*, 116: 550-558 (1954).
- D. E. A. Jones and H. C. Raine, "Mix D" or Phantowax Descriptions, correspondence, *Brit. J. Radiol.*, 22: 549-550 (1949).
- D. D. Lindsay and B. E. Stern, A New Tissue-like Material for Use as Bolus, *Radiology*, 60: 355-362 (1953).
- M. S. Livingston, Accelerators: High Energy, in "Medical Physics," Otto Glasser, editor, Vol. 2, pp. 1-20, Year Book Publishers, Inc., Chicago, Ill., 1950.
- Medical Research Council Unit, Christie Hospital, and Holt Radium Institute, Relative Biological Efficiency of 4-Mev and 300-kv Radiations, *Brit. J. Radiol.*, 30: 337-355 (1957).
- I. Meschan, G. Regnier, J. W. Nelson, and A. W. Lafferty, Dosage Tables for Cobalt 60 for Use with Interstitial, Plaque, and Intracavitary Applications, *Am. J. Roentgenol.*, 71: 320-332 (1954).
- W. S. Moos and E. W. Webster, An Automatic Tissue Dose Computer for Use in Supervoltage Rotational Therapy, *Radiology*, 59: 729-736 (1952).
- H. Nielsen, "Rotations Bestraaling: en Røntgenbestraalings-Methodik Belyst ved Dosismaalinger i Phantomer," Aarhus Vunivesitetsforlaget, Copenhagen, 1948.
- T. H. Oddie and I. Meschan, The Physical Aspects of the Utilization of the Tripartite Rigid Cobalt 60 Applicator for the Treatment of Carcinoma of the Cervix, *Radiology*, 64: 560-566 (1955).
- P. M. Pfalzner and W. R. Inch, Rotation Therapy with Cobalt 60 Unit. I. Physical Aspects of Circumaxial Rotation, *Acta. Radiol.*, 45: 51-61 (1956).
- J. E. Richardson, H. D. Kerman, and M. Brucer, Skin Dose from a Cobalt 60 Teletherapy Unit, *Radiology*, 63: 25-36 (1954).
- J. E. Roberts, Practical Implications of the 1953 Recommendations of the International Commission on Radiological Units, *Brit. J. Radiol.*, 28: 682-687 (1955).
- B. E. Stern, Dose Calculation for Moving Field Therapy, *Brit. J. Radiol.*, 29: 518-519 (1956).
- E. D. Trout, The History of High Energy Radiation Sources for Cancer Therapy, *Cancer Bulletin, Texas*, 8: 8-11 (1956).
- J. G. Trump, Physical Basis for the High Skin Tolerance of Supervoltage Roentgen Rays, *Radiology*, 50: 649-656 (1948).
- J. G. Trump, C. R. Mooster, and R. W. Cloud, Efficient Deep Tumor Irradiation with Roentgen Rays of Several Million Volts, *Am. J. Roentgenol.*, 57: 703-710 (1947).
- J. G. Trump, R. J. Van de Graaff, and R. W. Cloud, Cathode Rays for Radiation Therapy, *Am. J. Roentgenol.*, 43: 728-734 (1940).
- K. C. Telen, The Application of Automatic Computing Machines to Radiation Treatment Planning, *Brit. J. Radiol.*, 28: 432-439 (1955).
- T. J. Tulley, Instrumental and Technical Notes: Wedge Filters for Use with a 100-Curie Cobalt 60 Teletherapy Unit, *Brit. J. Radiol.*, 29: 227-229 (1956).
- R. Walstam, A Method for Three-dimensional Dose Finding in Teloradium Therapy, *Acta. Radiol.*, 43: 477-486 (1955).
- B. M. Wheatley, A Method of Dose Calculation with Applications to Moving Field Therapy, *Brit. J. Radiol.*, 28: 566-573 (1955).
- T. A. Watson, H. E. Johns, and C. C. Burkell, The Saskatchewan 1000-Curie Cobalt 60 Unit, *Radiology*, 62: 165-175 (1954).
- B. M. Wheatley, P. R. Steed, E. W. Savage, J. H. King, E. W. Forster, H. J. Hodt, I. R. Jones, and D. W. Smithers, The Two Million Volt Van de Graaff Generator Installation Designed for Rotation Therapy at the Royal Cancer Hospital, *Brit. J. Radiol.*, 26: 57-72 (1953).

1870
1871
1872
1873
1874
1875
1876
1877
1878
1879
1880
1881
1882
1883
1884
1885
1886
1887
1888
1889
1890
1891
1892
1893
1894
1895
1896
1897
1898
1899
1900

